

AUTODESK®
STONE® DIRECT
2007

Configuration Guide

Autodesk®

© 2007 Autodesk Canada Co./Autodesk, Inc. All Rights Reserved.

This publication, or parts thereof, may not be reproduced in any form, by any method, for any purpose.

AUTODESK CANADA CO./AUTODESK, INC., MAKES NO WARRANTY, EITHER EXPRESS OR IMPLIED, INCLUDING BUT NOT LIMITED TO ANY IMPLIED WARRANTIES OF MERCHANTABILITY OR FITNESS FOR A PARTICULAR PURPOSE REGARDING THESE MATERIALS. AND MAKES SUCH MATERIALS AVAILABLE SOLELY ON AN "AS-IS" BASIS. IN NO EVENT SHALL AUTODESK CANADA CO./AUTODESK, INC., BE LIABLE TO ANYONE FOR SPECIAL, COLLATERAL, INCIDENTAL, OR CONSEQUENTIAL DAMAGES IN CONNECTION WITH OR ARISING OUT OF ACQUISITION OR USE OF THESE MATERIALS. THE SOLE AND EXCLUSIVE LIABILITY TO AUTODESK CANADA CO./AUTODESK, INC., REGARDLESS OF THE FORM OF ACTION, SHALL NOT EXCEED THE PURCHASE PRICE, IF ANY, OF THE MATERIALS DESCRIBED HEREIN.

Autodesk Canada Co./Autodesk, Inc., reserves the right to revise and improve its products as it sees fit. This publication describes the state of this product at the time of its publication, and may not reflect the product at all times in the future.

The following are registered trademarks or trademarks of Autodesk, Inc., in the USA and other countries: 3DEC (design/logo), 3December, 3December.com, 3ds Max, ActiveShapes, Actrix, ADI, Alias, Alias (swirl design/logo), AliasStudio, Alias|Wavefront (design/logo), ATC, AUGI, AutoCAD, AutoCAD Learning Assistance, AutoCAD LT, AutoCAD Simulator, AutoCAD SQL Extension, AutoCAD SQL Interface, Autodesk, Autodesk Envision, Autodesk Insight, Autodesk Intent, Autodesk Inventor, Autodesk Map, Autodesk MapGuide, Autodesk Streamline, AutoLISP, AutoSnap, AutoSketch, AutoTrack, Backdraft, Built with ObjectARX (logo), Burn, Buzzsaw, CAiCE, Can You Imagine, Character Studio, Cinestream, Civil 3D, Cleaner, Cleaner Central, ClearScale, Colour Warper, Combustion, Communication Specification, Constructware, Content Explorer, Create>what's>Next> (design/logo), Dancing Baby (image), DesignCenter, Design Doctor, Designer's Toolkit, DesignKids, DesignProf, DesignServer, DesignStudio, Design|Studio (design/logo), Design Your World, Design Your World (design/logo), DWF, DWG, DWG (logo), DWG TrueConvert, DWG TrueView, DXF, EditDV, Education by Design, Extending the Design Team, FBX, Filmbox, FMDesktop, GDX Driver, Gmax, Heads-up Design, Heidi, HOOPS, HumanIK, i-drop, iMOUT, Incinerator, IntroDV, Kaydara, Kaydara (design/logo), LocationLogic, Lustre, Maya, Mechanical Desktop, MotionBuilder, ObjectARX, ObjectDBX, Open Reality, PolarSnap, PortfolioWall, Powered with Autodesk Technology, Productstream, ProjectPoint, Reactor, RealDWG, Real-time Roto, Render Queue, Revit, Showcase, SketchBook, StudioTools, Topobase, Toxik, Visual, Visual Bridge, Visual Construction, Visual Drainage, Visual Hydro, Visual Landscape, Visual Roads, Visual Survey, Visual Syllabus, Visual Toolbox, Visual Tugboat, Visual LISP, Voice Reality, Volo, and Wiretap.

The following are registered trademarks or trademarks of Autodesk Canada Co. in the USA and/or Canada and other countries: Backburner, Discreet, Fire, Flame, Flint, Frost, Inferno, Multi-Master Editing, River, Smoke, Sparks, Stone, Wire.

All other brand names, product names, or trademarks belong to their respective holders.

Third-Party Software Credits and Attributions

Portions of this software are copyright the FreeType Project (www.freetype.org). All rights reserved.

Apache License 2.0 – Perpetual, worldwide, non-exclusive, no-charge, royalty-free, irrevocable: (i) copyright license to reproduce, prepare derivative works of, publicly perform, publicly display, sublicense and distribute the Work and any Derivative Works in source or object form; (ii) patent license to make, have made, use, offer to sell, sell import and otherwise transfer the Work.

Powered by Automatic Duck. © 2006 Automatic Duck, Inc. All rights reserved.

Portions copyright 1991-2006 Compuware Corporation.

Portions of this product Copyright 2006 Glyph & Cog, LLC.

DIRAC Time Stretch/Pitch Shift technology licensed from The DSP Dimension, <http://www.dspdimension.com> Developed and (c) 2005 Stephan M. Bernsee.

This software uses the ffmpeg library, licensed under the LGPL license. See the file THIRD_PARTIES_LICENSES.txt (distributed with this software) for more details about ffmpeg licensing terms or visit: <http://ffmpeg.org/>

This software uses the libquicktime library, licensed under the LGPL license. See the file THIRD_PARTIES_LICENSES.txt (distributed with this software) for more details about libquicktime licensing terms or visit: <http://libquicktime.sourceforge.net/>

GOVERNMENT USE

Use, duplication, or disclosure by the U.S. Government is subject to restrictions as set forth in FAR 12.212 (Commercial Computer Software-Restricted Rights) and DFAR 227.7202 (Rights in Technical Data and Computer Software), as applicable.

Published By: Autodesk Canada Co./Autodesk, Inc.

111 McInnis Parkway
San Rafael, CA 94903, USA

Title: Autodesk Stone Direct 2007 Configuration Guide

Document Version: 4

Date: July 31, 2007



contents

Contents

1	Introduction	1
	Summary	1
	About This Guide	1
	Revision History	3
	Related Storage Documentation	3
	Storage Configuration Workflow	5
	Contacting Customer Support	6
2	Autodesk Stone Direct Storage Configurations	9
	Summary	9
	About Stone Direct	9
	XR-Series and IR-Series Disk Arrays	10
	RAID Strategy	10
	Physical Enclosures	11
	Enclosure Capacities	12
	XR-Series Storage Power and Air Conditioning Requirements	13
	Supported Drive RPMs	13
3	Safety and Work Environment Guidelines	15
	Summary	15
	About These Guidelines	15
	Setting Up Your Work Site and Handling Storage Hardware	15

	Establishing Ideal Environmental Conditions	16
	Avoiding Electrostatic Discharge	16
	Powering Up and Down	17
4	Workstation Connections	19
	Summary	19
	Understanding the Diagrams	19
	Cabling for 2- and 4-Port Fibre Channel Adapters	20
	HP xw8400	21
	HP xw9400	22
	IBM 6217 SC	24
	IBM 6217 DC	26
	IBM 6221	28
	IBM 6223	29
	IBM 6224	32
	IBM x346	32
	SGI Octane MXE	33
	SGI Octane2	34
	SGI Tezro	36
	SGI Onyx2	37
	SGI Onyx 3200	39
	SGI Onyx 350	42
5	Storage Connections	43
	Summary	43
	About 2-Loop and 4-Loop Configurations	43
	XR-Series	44
	IR-Series	47
	Disconnecting and Reconnecting Storage	52
6	Internal Storage Connections	53
	Summary	53
	About Internal Storage	53
	IBM 6217 SC	54

7	LUN Management Guidelines	57
	Summary	57
	About LUN Configuration	57
	Certified LUN Configurations	59
	Mounting the Storage CD on a Linux Workstation	59
	Accessing the RAID Controllers	59
	XR-Series LUN Creation Using the XR Configuration Utility	62
	XR-Series LUN Creation and Management Using the SSM Utility	65
	XR-Series LUN Mapping for Red Hat 3 Linux	73
	XR-Series LUN Mapping for Lustre Under Red Hat 3 Linux	78
	IR-Series LUN Creation and Management Using DSM	89
A	Recommended Inode Ratios for XR-Series	93
	Summary	93
	About This Appendix	93
	About Inodes and Inode Ratios	93
	Recommended Inode Ratio Tables	94
	Index	97

Summary

- [About This Guide](#) 1
- [Revision History](#) 3
- [Related Storage Documentation](#) 3
- [Storage Configuration Workflow](#) 5
- [Contacting Customer Support](#) 6

About This Guide

This document provides diagrams you use to connect your workstation to your Autodesk® Stone® Direct storage. It covers HP, IBM® and SGI® workstations, and both XR- and IR-series storage units.

Since a given workstation may work with various storage configurations, the diagrams are organized as two sets: a set that illustrates where to connect the fibre optic cables to your workstation, and a set that illustrates where to connect the fibre optic cables to your storage. Thus to connect your workstation to your storage, use the two diagrams that represent your configuration: one for the workstation and one for the storage.

 **WARNING:** The SGI warranty requires that only SGI-certified technicians install hardware and service the Origin™ 2000, Onyx2®, Onyx® 3200, and Onyx 350. Failure to comply may void the warranty. Contact SGI for more information. Installing hardware on and servicing the Octane®, Octane2™, and Tezro™ platforms should only be carried out by an experienced technician.

Audience Assumptions

Basic knowledge of UNIX (or Windows for Autodesk Lustre® systems running under Windows), and computer hardware in a professional video/film production environment is assumed throughout this guide. Do not attempt to carry out the procedures outlined in this guide if you do not have this knowledge.

Terminology

The following terms are used throughout this guide.

Term	Description
Disk array	XR- or IR-series disk array
Enclosure	Synonym for disk array
Unit	Synonym for disk array
XR-Series	XR enclosure, XE enclosure
XR	XR-Series RAID enclosure
XE	XR-Series RAID expansion enclosure
EBOD	Expansion Bunch Of Disks (synonym for XE)
IR-Series	IR36, IR36-HR, IR73, IR73-HR, IR146, IR146-HR, IR300, IR300-HR
JBOD	Just a Bunch Of Disks. There are two types: one for software RAID configurations and one for hardware RAID configurations.
Loop	A workstation-to-storage fibre channel connection
Storage assembly	A storage assembly consists of one enclosure connected to your workstation, and any additional enclosures daisy-chained to that enclosure.
Stone filesystem	A UNIX kernel driver that is used to control the storage of material on a Stone disk array. The Stone filesystem is optimized for managing large multimedia files.
Stone filesystem partition	A logical division of the Stone filesystem. When you configure the Stone filesystem, you decide how many partitions you will use.

Notation Conventions

A number of style conventions are used throughout this guide. These conventions and examples of their use are shown as follows.

Convention	Example
Text that you enter in a command line or shell appears in Courier bold. You must press the Enter key after each command.	rpm -qa
Variable names appear in Courier, enclosed in angle brackets. No spaces are allowed in variable names.	<variable_name>
Variables that appear enclosed in square brackets are optional.	[<filename>]
Feedback from the command line or shell appears in Courier.	limit coredumpsize
Directory names, filenames, URLs, and command line utilities appear in italics.	<i>/usr/discreet</i>

Commands

The IRIX® and Linux® operating systems are case sensitive. You must type commands, file names, and pathnames exactly as they appear in this guide. For more information on the commands used when configuring hardware, refer to the online operating system documentation. In a shell, type **man** followed by the name of the command. For example, type: **man cp** to display information on copying files.

Revision History

This document is updated as necessary throughout the life cycle of the release. This section describes all additions and modifications made to this document since its initial publication. The latest version of this document is available at <http://www.autodesk.com/discreet-documentation>. It is recommended that you always refer to the most recent version, to ensure you are working with the most up-to-date information.

NOTE: Minor changes, such as typographical errors or changes to names of sections, that do not have an impact on the technical content of the guide are not included in this revision history.

Modification	Item	Page	Release
Added	Revision History	3	2007
Updated	Step 8 of the XR LUN configuration Workflow	5	2007
Added	XR Power and Air Conditioning Requirements	13	2007
Added	Lustre/Incinerator Storage on HP Workstations	22	2007
Updated	Workstation Connections for the HP 9400	22	2007
Added	Proper Ventilation Warning for Internal Drives	53	2007
Updated	"XR-Series LUN Creation Using the XR Configuration Utility" on page 62	62	2007 SP5
Updated	"Recommended Inode Ratio Tables" on page 94	94	2007 SP5

Related Storage Documentation

This section lists documentation related to Stone Direct disk arrays. All documentation listed here is available in PDF format from the Web at <http://www.autodesk.com/discreet-documentation>, in either the Storage section or the Stone and Wire section. For best results viewing and printing these PDF files, use XPDF or Adobe® Acrobat® Reader™.

Related Documentation for Both XR- and IR-Series Disk Arrays

The following documentation contains information related to Stone Direct storage.

- *Storage vs Systems Matrix* This document lists all storage configurations available for each of the current generation of systems. If your system is one of an earlier generation, refer to the *Stone Direct Configuration Guide, 7th Edition*.
- *Stone and Wire Filesystem and Networking Guide* for your release

In addition to the above, the release notes for your application, and the fixed and known bug list for your release may also contain information on Stone Direct storage.

XR-Series Related Documentation

The following documentation contains detailed information on the XR-Series disk arrays. Both documents are available in PDF format on the CD that shipped with your storage. The most recent version of each is available on the Web site.

- *Autodesk Stone Direct 2007 Storage Manager User's Guide*
- *Autodesk XR/XE RAID Solution Maintenance Guide*

IR-Series Related Documentation

The following documentation contains information related to the IR-Series disk arrays. PDFs of all documents are available in the *Storage/V3 Supplementary Documentation* folder of the Web site, as well as on the CD that shipped with your storage.

- *Discreet Storage Manager Installation and User's Guide, 3rd Edition*
Certain sections of this guide are superseded by information in the *Discreet Storage Manager Release Notes, 2nd Edition*.
- *Discreet Storage Manager Release Notes, 2nd Edition*
- *Configuring Hardware RAID with Stone and Wire, 2nd Edition*
- *Installation and Hardware Reference Guide, 3rd Edition*
- *Embedded Configuration Utility User's Guide, 3rd Edition*
- *Electromagnetic Compatibility Statements, 3rd Edition*
- *Translated Safety Notices, 3rd Edition*
- *Troubleshooting a RAID Controller Failure, 2nd Edition*

Storage Configuration Workflow

This section presents the workflow for setting up and configuring Stone Direct storage from scratch. It is intended to provide context for the current document, and ensure you have completed the necessary hardware setup prior to connecting your Stone Direct storage.

To set up and configure Stone Direct storage:

1. Verify that all peripheral, video and hardware components of your system are properly wired. Refer to the appropriate *Hardware Setup Guide* for your workstation.
2. Understand the different components of your storage configuration. See [Chapter 2, “Autodesk Stone Direct Storage Configurations.”](#) on page 9.
3. Review the safety and work environment guidelines in this guide. See [Chapter 3, “Safety and Work Environment Guidelines.”](#) on page 15.
4. Physically connect the Stone Direct storage to your workstation using the diagrams in this guide. You use two diagrams to connect the fibre optic cables: the first illustrates the connectors on your workstation, and the second illustrates the connectors on the storage unit (or units). Refer to the appropriate diagrams for your system in [Chapter 4, “Workstation Connections.”](#) on page 19 and for your storage configuration in [Chapter 5, “Storage Connections.”](#) on page 43.
5. Power on the storage.

NOTE: In a hardware RAID configuration, the sequence in which you power the units on or off is important: the RAID controller must be able to detect the other units in the Stone Direct storage at all times. Thus when you power on the hardware RAID, the last unit you power on is the RAID controller. When you power off the hardware RAID, the first unit you power off is the RAID controller. For an explanation of the difference between hardware and software RAID, see [“RAID Strategy”](#) on page 10.

6. Power on your workstation.
7. Check the *Hardware Setup Guide* for your workstation as well as the *Release Notes* for your application for any release-specific workstation or fibre channel BIOS settings, and verify these match with those of your workstation and fibre channel adapters.
8. Configure logical volumes (LUNs) on RAID controllers using the XR configuration utility. Refer to the [Appendix , “XR-Series LUN Creation Using the XR Configuration Utility.”](#) on page 62 for more information on how to proceed for your storage configuration.
9. Install your Editing or Effects, or Lustre application.

10. Create the filesystem. For Lustre, refer to the installation documentation for your Lustre release. For Editing or Effects products refer to one of the following for help creating the Stone filesystem:
 - If you are using a software RAID configuration, or you are not using RAID, refer to the *Stone and Wire Filesystem and Networking User's Guide*.
 - If you are using a hardware RAID configuration with XR-series units, refer to the documents for the Autodesk Stone Direct 2007 Storage Manager listed in [“XR-Series Related Documentation”](#) on page 4.
 - If you are using a hardware RAID configuration with IR-series units, refer to the documents for the Discreet Storage Manager (DSM) listed in [“IR-Series Related Documentation”](#) on page 4.
11. Once you complete the setup of your Stone Direct storage, if you need to configure Wire networking, refer to the *Stone and Wire Filesystem and Networking Guide*.

Contacting Customer Support

You can contact Autodesk Media and Entertainment Customer Support at www.autodesk.com/support or in one of the following ways.

Location:	Contact Information:
Within the Americas:	Hotline (North America): 1-800-925-6442 Direct dial: 415-507-5256 (Country code = 1) 8 AM to 8 PM EST Monday to Friday, excluding holidays me.support@autodesk.com
Within Europe, Middle-East and Africa:	Hotline (from London, UK): +44-207-851-8080 9 AM to 5:30 PM (local time) Monday to Friday, excluding holidays me.emea.support@autodesk.com
Within Asia Pacific: (Excluding India, China, Australia, New Zealand and Japan)	Hotline (from Singapore): +65-6555-0399 9 AM to 6 PM (local time) Monday to Friday, excluding holidays me.support.singapore@autodesk.com
Within India:	Hotline (from Mumbai): +91-22-6695-2244 9:30 AM to 6:30 PM (local time) Monday to Friday, excluding holidays me.support.india@autodesk.com

Location:	Contact Information:
Within Japan:	Hotline (from Tokyo): 0120-107-290 Direct dial: +81-3-6221-1810 10 AM to 6 PM (local time) Monday to Friday, excluding holidays <i>med-sys-support-jp@autodesk.com</i>
Within China:	Direct dial: +86-10-6505-6848 9 AM to 6 PM (local time) Monday to Friday, excluding holidays <i>me.support.china@autodesk.com</i>
Within Australia and New Zealand:	Hotline (from Melbourne): +1-300-36-8355 Direct dial: +61-3-9876-8355 8 AM to 6 PM AEST Monday to Friday, excluding holidays <i>me.support.anz@autodesk.com</i>

Customer support is also available through your Autodesk reseller. To find a reseller near you, consult the reseller look-up database on the Autodesk web site at www.autodesk.com/resellers.



Autodesk Stone Direct Storage Configurations

Summary

About Stone Direct	9
XR-Series and IR-Series Disk Arrays	10
RAID Strategy	10
Physical Enclosures	11
Enclosure Capacities	12
XR-Series Storage Power and Air Conditioning Requirements	13
Supported Drive RPMs	13

About Stone Direct

Stone Direct is Autodesk’s high-performance direct-attached storage, designed to address the different real-time playback requirements of SD, HD, 2K film, and mixed resolution workflows.

The following three components are required in a system that uses Stone Direct storage:

Component	Description
One or more disk arrays	The physical storage units
Stone filesystem	The filesystem that determines how disk arrays are partitioned and media is stored on disk arrays
Editing or Effects application	The way you access the media on the disk arrays

In the simplest configuration a Stone Direct consists of a single disk array attached using fibre channel cables to a workstation running an Editing or Effects application. More complex configurations consist of two or more disk arrays, daisy-chained together and attached to the workstation. The capacity of each disk array varies with the number of disks it contains and the capacity of each of the disks. The capacity of the Stone Direct in turn depends on the capacity of each disk array and the number of disk arrays it contains.

Stone Direct storage is flexible and scalable. You can increase storage capacity by adding disk arrays. Note however that the Stone Direct configurations available may vary with the workstation running your Editing or Effects application, and the version of that application. For

a list of the Stone Direct configurations available for each of the current generation of platforms, see the *Storage vs Systems Matrix*, available in the Storage section of the Web site at www.autodesk.com/discreet-documentation. If your platform is an older generation system, refer to the *Stone Direct Configuration Guide, 7th Edition* for help determining the storage configurations currently supported on your platform.

XR-Series and IR-Series Disk Arrays

XR-series and IR-series refer to the disk arrays used to build the Stone Direct configuration. The XR-series is the new generation of storage and the IR-series is the previous generation.

XR-Series Disk Arrays

The XR-series includes the XR146 and XE146 disk array types. Each XR-series disk array contains twelve 146 GB hard drives. For technical specifications, assembly, and maintenance information, refer to the *XR/XE RAID Solution Maintenance Guide*.

IR-Series Disk Arrays

A single IR-series disk array holds fifteen 36-, 73-, 146-, or 300-GB hard drives. For technical specifications, refer to Chapter 2, “Product Characteristics,” in the *Installation and Hardware Reference Guide, 3rd Edition*. For further information on the IR-series units, including components, assembly, and troubleshooting, refer to the other documents listed in [“IR-Series Related Documentation”](#) on page 4.

NOTE: The IR-series superseded the D-series and R-series of disk arrays. For help with D- and R-series disk arrays, refer to the *Discreet Storage Configuration Guide, 6th edition*.

RAID Strategy

Stone Direct storage uses RAID (Redundant Array of Independent Disks) to provide high performance, reliability, and protection against data loss. RAID combines many hard disks into a single logical disk to obtain I/O performance levels that cannot be obtained with a single disk.

RAID can be either hardware- or software-based. Hardware RAID means RAID operations are performed by a hardware RAID controller included in the disk array enclosure. Software RAID means RAID operations are performed by the CPU of your workstation. Hardware RAID has the advantage of a dedicated CPU that substantially improves throughput and does not impact workstation performance.

Note the following with respect to Stone Direct RAID strategies:

- Although not recommended, you can disable software RAID in Stone and Wire. In this case, if a drive failure occurs, media is permanently lost.
- Software RAID configurations have never been available for Linux systems.
- Although hardware RAID is the only option for the XR-series, Autodesk continues to support both hardware and software RAID configurations on IR-series disk arrays.

Physical Enclosures

The XR- and IR-series both provide two types of enclosures: a RAID enclosure and either an EBOD (Expansion Bunch Of Disks) enclosure (also called an XE enclosure) in the case of the XR-series, or a JBOD (Just a Bunch Of Disks) enclosure in the case of the IR-series.

NOTE: RAID, JBOD, and EBOD enclosures are not interchangeable. Each type of enclosure has its own firmware, Ethernet ports, fibre channel ports and expansion ports (EBOD enclosures use Serial Attached SCSI (SAS) expansion ports, JBOD expansion enclosures use fibre channel (FC) expansion ports). Also, you cannot mix and match enclosures with different disk sizes; all disks in all enclosures in a storage configuration must be of the same size and series.

Hardware RAID storage configurations require either one RAID enclosure (for 2-loop) or two RAID enclosures (for 4-loop). These configurations may include additional XE (XR-series) or hardware RAID JBOD (IR-series) expansion enclosures. RAID enclosures contain hardware RAID controllers. The RAID enclosure or enclosures perform RAID operations for all enclosures in the configuration.

Software RAID configurations use only software RAID JBOD units; your workstation performs software RAID operations for all enclosures in the configuration.

XR-Series Enclosures

The following illustrations show, respectively, the XR-series RAID and EBOD enclosures.

XR RAID Enclosure

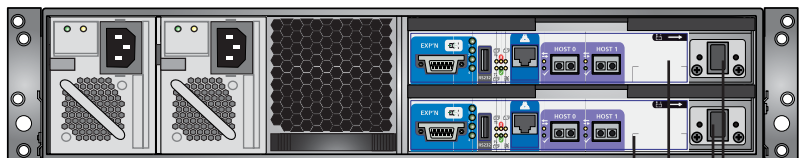

Hardware RAID Controllers

Battery Backup Units

XE (EBOD) Expansion Enclosure

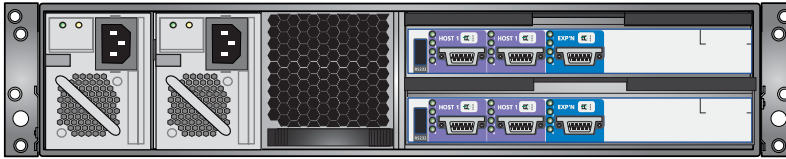

IR-Series Enclosures

The following illustrations show, respectively, the IR-series RAID and JBOD enclosures. There are two types of JBOD enclosures: enclosures used in software RAID configurations (JBOD enclosures) and JBOD enclosures used in hardware RAID configurations (JBOD expansion enclosures). Although there is no physical difference between the two, the different firmware each uses means the two types cannot be interchanged between hardware and software RAID configurations.

IR-Series RAID Enclosure

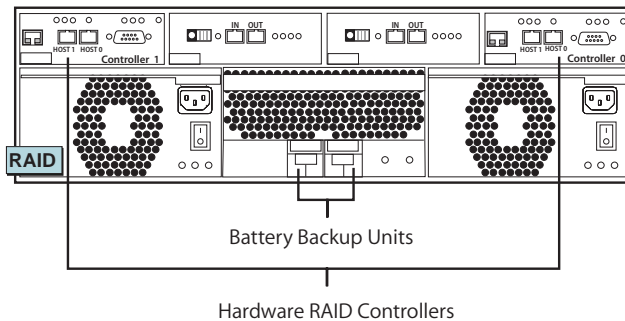

IR-Series JBOD Enclosure

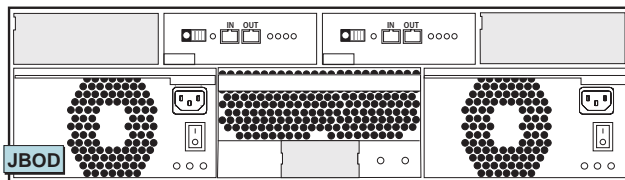

Enclosure Capacities

Usable capacities for enclosures, based on drive capacity and number of enclosures, are listed in the tables in [Appendix A, “Recommended Inode Ratios for XR-Series.”](#) on page 93.

XR-Series Storage Power and Air Conditioning Requirements

The following table summarizes the power consumed by XR-series storage solutions and the heat they can generate from continuous access by your application. For detailed specifications, including noise output, see the documentation provided by the manufacturer.

Component	Quantity	Startup Amps (120V / 240V)	Cont' Amps (120V / 240V)	Watts	Heat (BTUs)
XR RAID Enclosure	1	5.5 / 2.8	3.0 / 1.5	360	1228.68
XE Expansion Enclosure	1	5.5 / 2.8	3.0 / 1.5	360	1228.68
XR RAID with 1 XE	-	11 / 5.5	5.5 / 2.8	660	2252.58
XR RAID with 2 XE	-	16.5 / 8.3	8.0 / 4.0	960	3276.48

You must be able to meet the startup power requirements and have a climate control system with the capacity to maintain the temperature of these components during continuous access. Refer to the following table for standard conversion benchmarks and an example of how they are used to establish climate control requirements.

Unit Conversion	Example
1 Watt = 3.413 BTU	360 Watts = 1228.68 BTU
12000 BTU = 1 Ton of air conditioning	1228.68 BTU = 1.024 Ton of air conditioning

Supported Drive RPMs

The RPM (Revolutions Per Minute) of the disks in the enclosure is important as not all RPM values are supported in all Stone Direct storage configurations. If your workstation is among the current generation of platforms, consult the *Storage vs Systems Matrix* document available on the Web site to determine which RPM values are supported by your storage configuration. If your platform is one of an earlier generation, refer to the *Stone Direct Configuration Guide, 7th Edition* for help determining the RPM values supported by your storage configuration.

3

Safety and Work Environment Guidelines

Summary

About These Guidelines	15
Setting Up Your Work Site and Handling Storage Hardware	15
Establishing Ideal Environmental Conditions	16
Avoiding Electrostatic Discharge	16
Powering Up and Down	17

About These Guidelines

This chapter presents essential precautions you should review prior to installing and configuring your Stone Direct storage. These considerations and site preparations will help ensure a safe installation.



WARNING: All safety and work environment guidelines presented in this chapter relate to Stone Direct disk arrays only and do not replace or modify guidelines or requirements set by the manufacturers of the workstation or of the peripheral devices attached to your system.

Setting Up Your Work Site and Handling Storage Hardware

Guidelines for setting up your workspace and handling your storage hardware are included in the documentation for your disk array.

- For XR-series disk arrays, refer to Chapter 2, “Getting Started” in the *XR/XE RAID Solution Maintenance Guide*.
- For IR-series disk arrays, refer to Chapter 3, “Installing, Connecting, and Powering On a Discreet Storage Array,” in the *Installation and Hardware Reference Guide, 3rd Edition*.

Establishing Ideal Environmental Conditions

The following guidelines describe the ideal environmental conditions for your disk array to function properly. Ensure these conditions are met:

- Room temperature and ambient humidity are at acceptable levels.
- The disk array is at room temperature before operating.
- The environment is clean and dust-free.
- Disk array fans are not obstructed. Do not drape anything, such as a jacket or blanket, over any part of the system.
- There is good air circulation.
- The environment has minimal vibration and humidity.
- Electromagnetic noise is minimal by separating digital data and power cables from analog audio cables and running them in different cable ducts.
- The power requirements of the system are met by your electrical installation.
- Any cable ties you use to bundle cables together are slack enough to prevent damage to the wires inside the cables, and any loops in optical cables are relaxed enough to prevent damage to the optical fibres inside the cables (for example, no smaller than two centimeters in diameter). Damage to wires or optical fibres can render cables unstable or completely unusable.

Avoiding Electrostatic Discharge

By eliminating the possibility of electrostatic discharge, you ensure a safe work environment. As well, disk array components are less likely to be damaged. The following safety guidelines minimize the possibility of electrostatic discharge.

- Power your system on and off according to the procedures in the section [“Powering Up and Down”](#) on page 17.
- Using a grounded static wrist strap, attach the strap’s alligator clip to any grounded metal surface on the disk array enclosure and place the wristband on your wrist.
- Stand on a conductive rubber mat.
- Do not handle the boards for the disk arrays or workstations unnecessarily. Take special care to avoid damaging the CPOP covers on SGI workstations; CPOP connectors can be easily damaged if handled improperly.
- Read and observe warning labels on enclosures and drives.
- Call Customer Support for repair/replacement of disk drives or circuitry within the enclosure by using one of the methods listed in [“Contacting Customer Support”](#) on page 6.

NOTE: The power supplies for all Stone Direct disk arrays are universal, and therefore automatically detect the correct voltage for your country.

Powering Up and Down

Powering your system up or down should be done in a proper sequence. This will ensure that the system functions properly.

 **WARNING:** It is critical that you follow the correct sequence when powering your system up and down to ensure proper operation of the storage configuration. An incorrect sequence can mean your system does not recognize all drives.

To power up your system:

1. Power up all disk arrays.
If your storage uses hardware RAID and includes EBOD (XR-series) or JBOD (IR-series) units, be sure to power on the RAID units last. This ensures the RAID controllers detect the other units in the Stone Direct storage.
2. Wait about 60 seconds for all the drives to spin up.
3. Power up your workstation.

To power down your system:

1. Power down your workstation. If you are on a UNIX system, in a Terminal (Linux) or shell (IRIX), as root, type:
shutdown -g0
2. Wait for your workstation to shut down completely and power off. If the system does not power off automatically, power it off manually.
3. Power down your disk arrays.
If your storage uses hardware RAID and includes EBOD (XR-series) or JBOD (IR-series) units, be sure to power off the RAID units first. This ensures the RAID controllers can always detect the other units in the Stone Direct storage.

Workstation Connections



Summary

<u>Understanding the Diagrams</u>	19
<u>Cabling for 2- and 4-Port Fibre Channel Adapters</u>	20
<u>HP xw8400</u>	21
<u>HP xw9400</u>	22
<u>IBM 6217 SC</u>	24
<u>IBM 6217 DC</u>	26
<u>IBM 6221</u>	28
<u>IBM 6223</u>	29
<u>IBM 6224</u>	32
<u>IBM x346</u>	32
<u>SGI Octane MXE</u>	33
<u>SGI Octane2</u>	34
<u>SGI Tezro</u>	36
<u>SGI Onyx2</u>	37
<u>SGI Onyx 3200</u>	39
<u>SGI Onyx 350</u>	42

Understanding the Diagrams

The diagrams in this chapter illustrate the fibre channel connections on the back panel of the workstation, and the corresponding connection on the storage enclosure. Note the following about the diagrams:

- All diagrams are independent of the specific type of XR- or IR-series enclosures available for a system. Use the same diagram to connect either storage series.
- If both 2-loop and 4-loop configurations are available for a workstation, both are illustrated in the same diagram. If you are configuring a 2-loop configuration, ignore the connections for the second storage assembly. For an explanation of 2-loop and 4-loop configurations, and

“first storage assembly” and “second storage assembly” references, see [“About 2-Loop and 4-Loop Configurations”](#) on page 43.

- Labels for fibre channel ports correspond to the default port numbers assigned by the operating system. For example, on a 4-port fibre channel adapter, the left-most port is port 1 and the right-most port is port 4; the corresponding labels on the diagram are “FC Loop 1” and “FC Loop 4”.
- The diagrams in this chapter illustrate only one fibre channel adapter or fibre channel adapter combination per workstation. In cases where the diagram does not reflect your fibre channel adapter configuration, refer to [“Cabling for 2- and 4-Port Fibre Channel Adapters”](#) on page 20 to determine which ports to connect to storage.

Cabling for 2- and 4-Port Fibre Channel Adapters

Workstations may be equipped with either or both 2-port and 4-port fibre channel adapters, depending on the storage configurations available for that workstation. If the diagram for your workstation does not reflect your fibre channel adapter configuration, use the following to determine which ports to connect to storage:

- If the diagram illustrates a 4-port adapter and yours is a 2-port adapter, the illustration should show connections for only the two innermost ports of the four ports. Ignore the two outermost ports and cable according to the two innermost ports.
- If the diagram illustrates a 2-port adapter, and yours is a 4-port adapter, connect the two innermost ports to Stone Direct storage as indicated in the following diagram. Note that with a 4-port adapter you can connect the two outermost ports to archiving devices, or to a Stone Shared Storage Area Network (SAN) system. Depending on your configuration, it may also be possible to connect all four ports to a SAN.

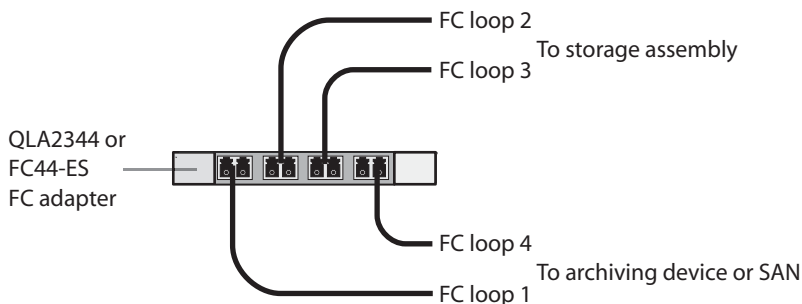

Terminating 4-Port Fibre Channel Adapters

If you are not using the two outermost ports of a 4-port fibre channel adapter, it is recommended that you terminate these ports using the FC loopback couplers that shipped with your system. Terminating these ports significantly decreases the time required to boot the system.

HP xw8400

The following diagrams illustrate 2-loop (and optional 4-loop) connections for an Effects or Editing configuration and a Lustre (Windows) configuration on the HP xw8400 workstation.

NOTE: Remember that any unused ports on a 4-port adapter should be terminated using FC loopback couplers.

HP xw8400 Workstation
Effects or Editing (SD/HD/DI/2K)

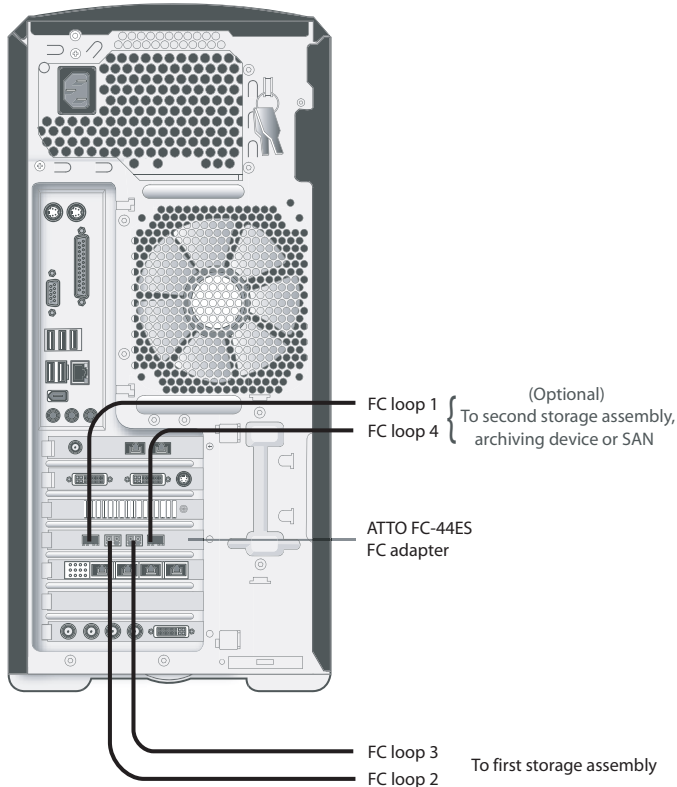

HP xw8400 Workstation
Lustre (Windows Configuration)

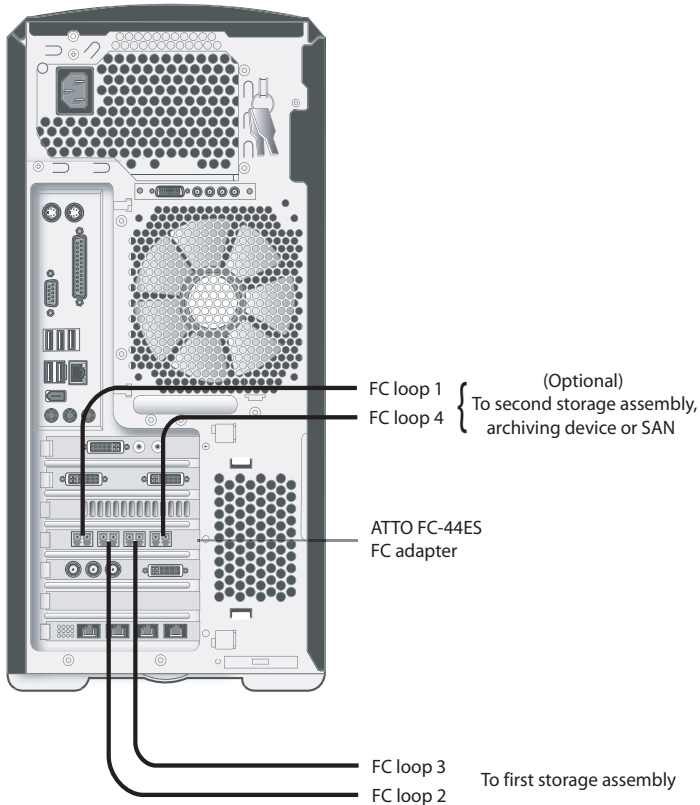

NOTE: HP xw8400 workstations running Lustre (Linux) with Autodesk Incinerator® do not support direct attached storage.

HP xw9400

The first of the following diagrams illustrates 2-loop and optional 4-loop connections for an Effects or Editing configuration running on the HP xw9400 workstation. The second diagram illustrates 2-loop and optional 4-loop connections for a Lustre Media Server running on the HP xw9400 workstation.

NOTE: Remember that any unused ports on a 4-port adapter should be terminated using FC loopback couplers.

HP xw9400 Workstation
Effects or Editing

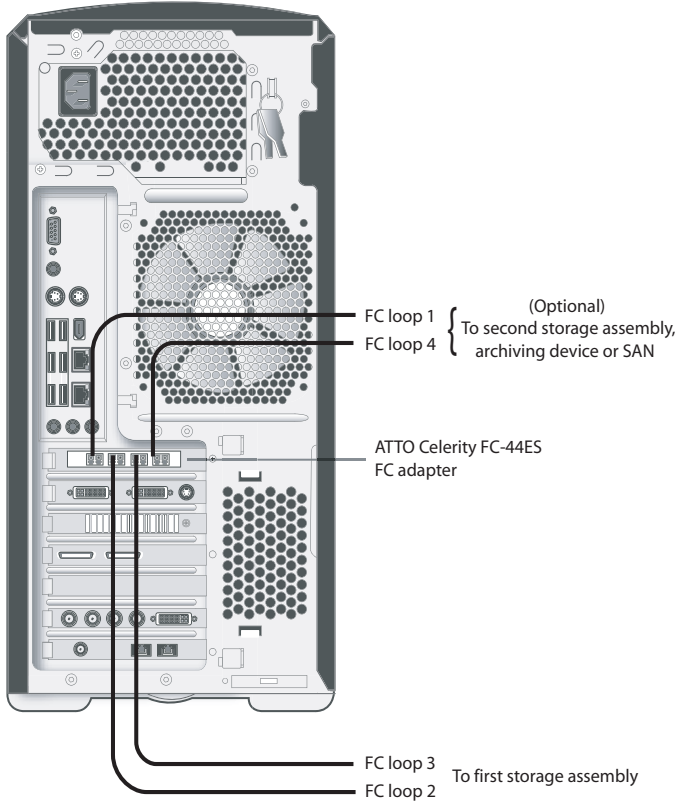

HP xw9400 Workstation
Incinerator Lustre Media Server

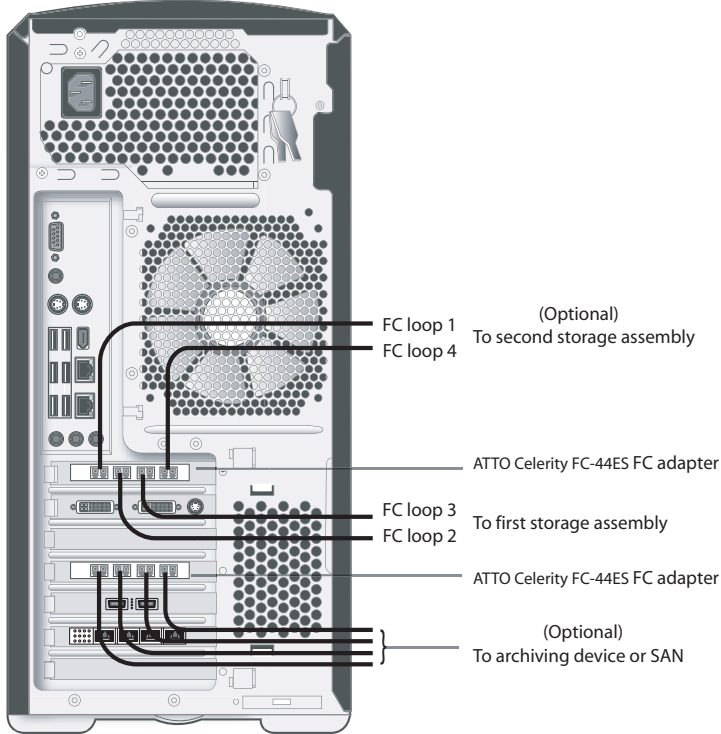

IBM 6217 SC

The following diagram at left illustrates 2-loop connections for an HD configuration of the IBM 6217 Single Core workstation. The diagram at right illustrates 2-loop connections for an SD configuration.

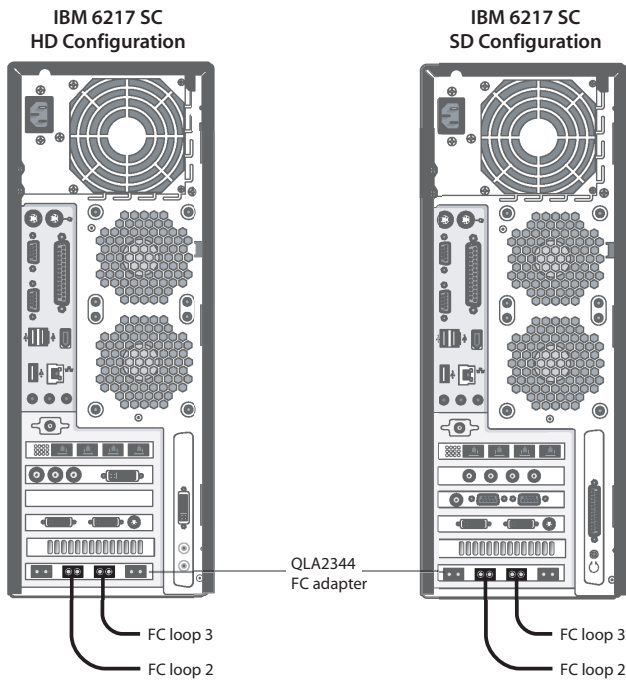

NOTE: If the number of ports in the fibre channel adapters in your workstation are not as shown in the diagram, refer to [“Cabling for 2- and 4-Port Fibre Channel Adapters”](#) on page 20 for help determining which ports to connect to storage. Also remember that any unused ports on a 4-port adapter should be terminated using FC loopback couplers.

IBM 6217 DC

The first diagram illustrates 2-loop and 4-loop connections for an IBM 6217 Dual Core workstation equipped with either two QLA2342 adapters, or one QLA2342 and one QLA2344 adapter.

The second diagram illustrates 2-loop and 4-loop connections for an IBM 6217 Dual Core workstation equipped with two QLA2344 adapters, and running the 2007 release of an Effects or Editing application. The upgrade to the 2007 release requires that you swap the locations of the DVS Centaurus board in slot 2 and the QLA 2344 adapter in slot 3, as described in the release notes for 2007 Effects and Editing applications, and shown in the diagram.

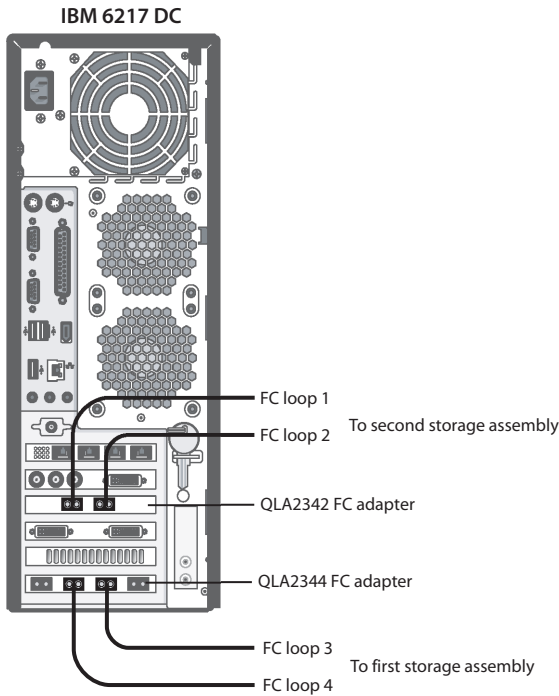

**IBM 6217 DC
Dual QLA2344 Configuration
for 2007 Applications**

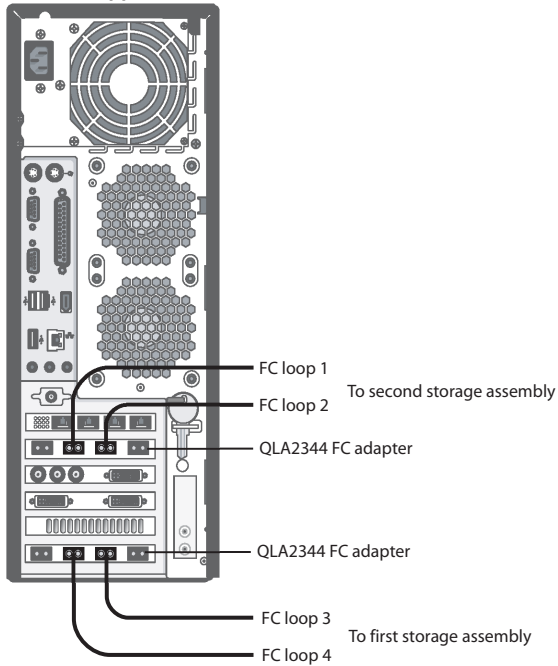

NOTE: Remember that any unused ports on a 4-port adapter should be terminated using FC loopback couplers.

IBM 6221

The following diagram at left illustrates 2-loop connections for Editing and Effects products on the IBM 6221 workstation. The diagram at right illustrates 2-loop and 4-loop connections for Lustre running under Windows on the IBM 6221 workstation.

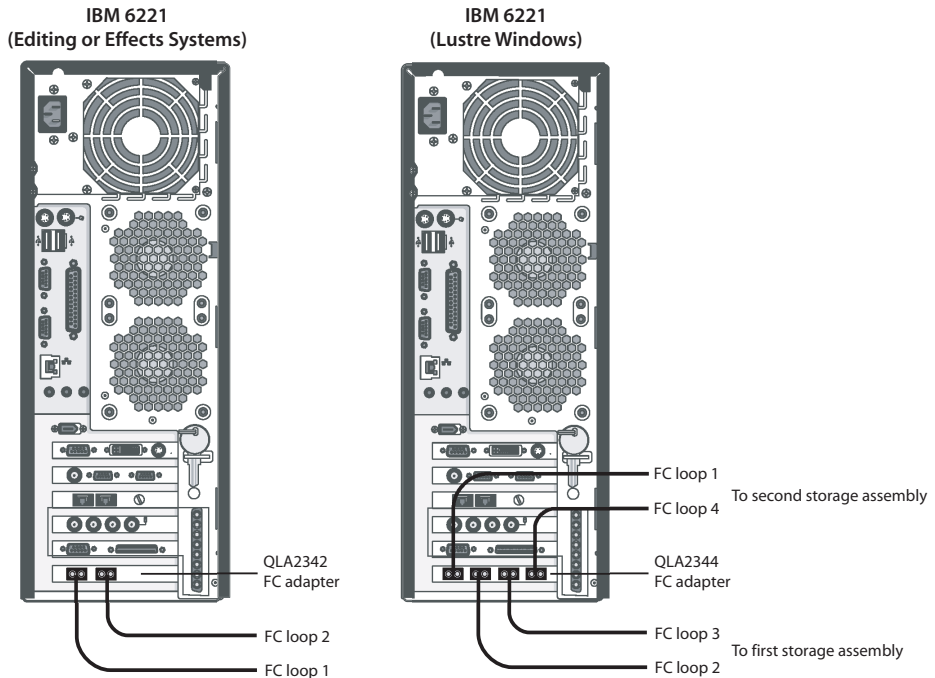

NOTE: Your workstation may be equipped with an NVIDIA® FX4000 graphics card rather than the NVIDIA FX3000 card shown in the diagrams.

NOTE: If the number of ports in the fibre channel adapters in your workstation are not as shown in the diagram, refer to [“Cabling for 2- and 4-Port Fibre Channel Adapters”](#) on page 20 for help determining which ports to connect to storage. Also remember that any unused ports on a 4-port adapter should be terminated using FC loopback couplers.

IBM 6223

These diagrams illustrate connections for Lustre running on the IBM 6223 workstation. The first illustrates 4-loop connections with two storage assemblies for Lustre running under Linux. The second illustrates 4-loop connections with a single storage assembly for Lustre running under Linux. The third illustrates 2-loop and 4-loop connections for Lustre running under Windows.

NOTE: If the number of ports in the fibre channel adapters in your workstation are not as shown in the diagram, refer to [“Cabling for 2- and 4-Port Fibre Channel Adapters”](#) on page 20 for help determining which ports to connect to storage. Also remember that any unused ports on a 4-port adapter should be terminated using FC loopback couplers.

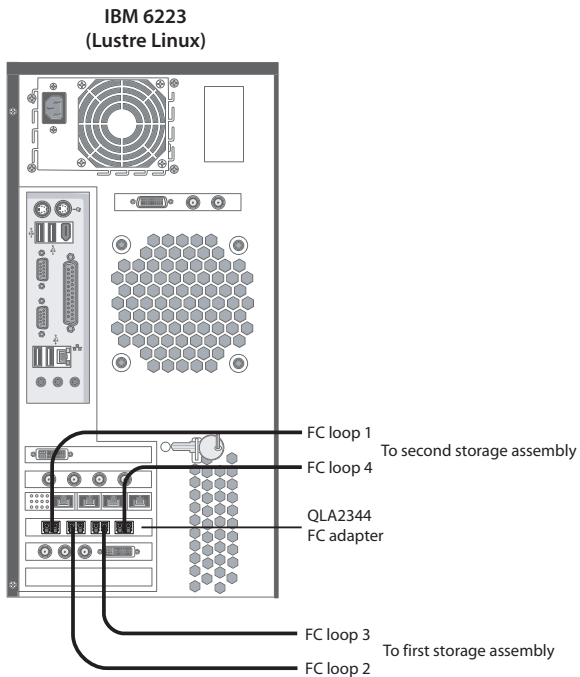

4 Workstation Connections

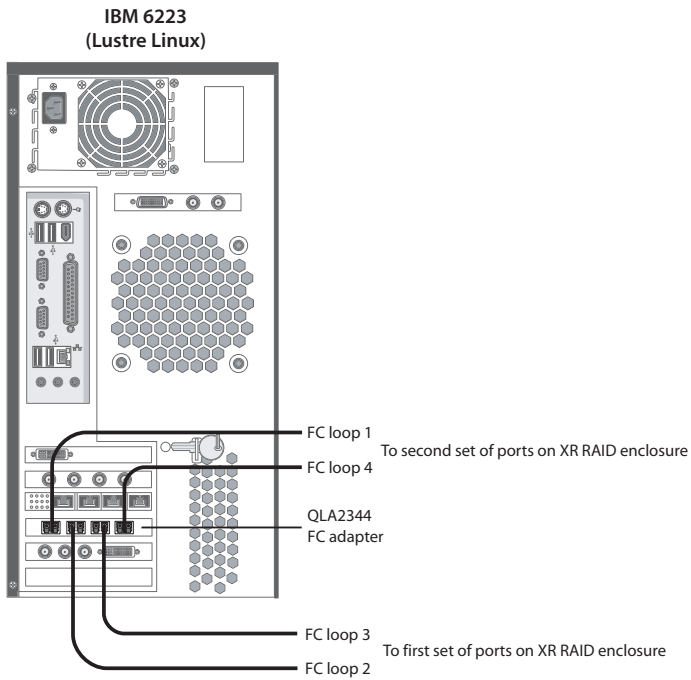

**IBM 6223
(Lustre Windows)**

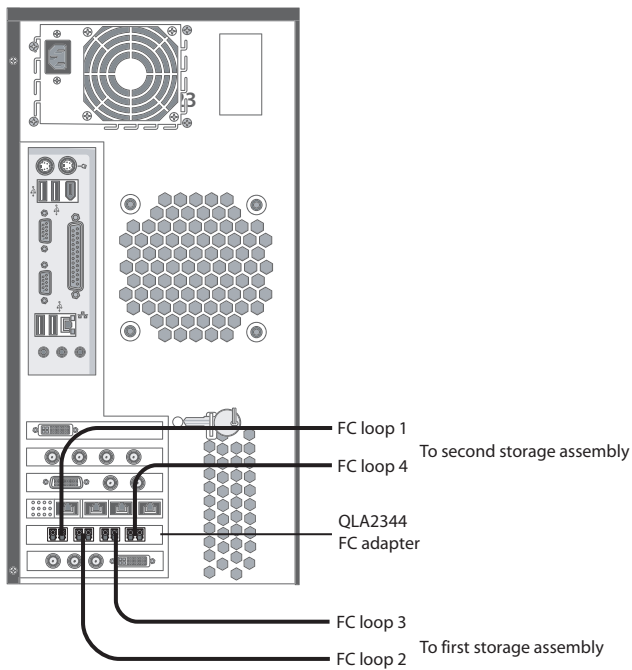

NOTE: The graphics card as well as the position of the DVS Centaurus daughter board in your workstation may vary from those shown in the diagram.

IBM 6224

This diagram illustrates 2-loop connections for the IBM 6224 workstation.

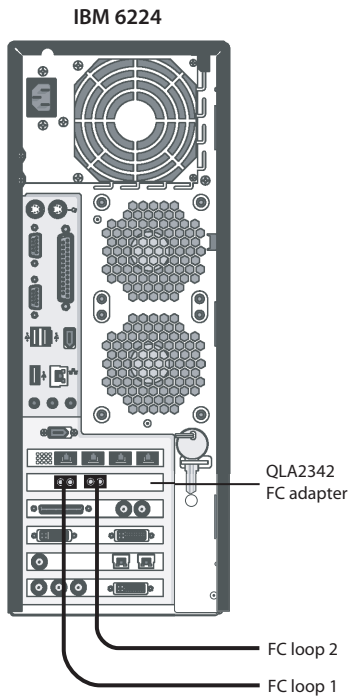

NOTE: If the number of ports in the fibre channel adapters in your workstation are not as shown in the diagram, refer to [“Cabling for 2- and 4-Port Fibre Channel Adapters”](#) on page 20 for help determining which ports to connect to storage. Also remember that any unused ports on a 4-port adapter should be terminated using FC loopback couplers.

IBM x346

This diagram illustrates 2-loop and 4-loop connections for Autodesk Lustre Media Server (Incinerator) running on the IBM x346 workstation.

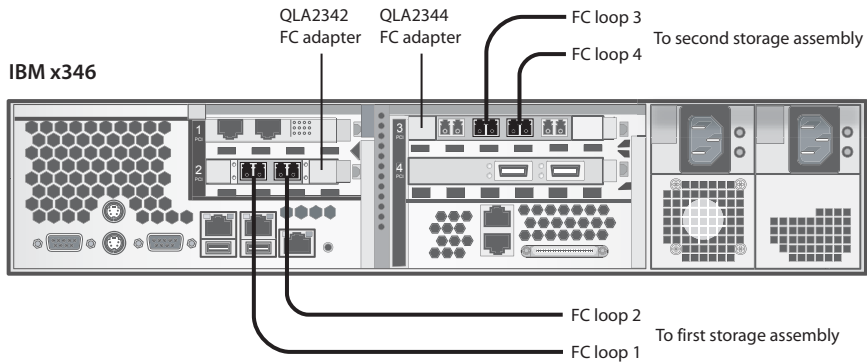

NOTE: If the number of ports in the fibre channel adapters in your workstation are not as shown in the diagram, refer to [“Cabling for 2- and 4-Port Fibre Channel Adapters”](#) on page 20 for help determining which ports to connect to storage. Also remember that any unused ports on a 4-port adapter should be terminated using FC loopback couplers.

SGI Octane MXE

The diagrams in this section illustrate 2-loop connections for the SGI Octane MXE workstation. The first illustrates connections for workstations equipped with the SGI dual port fibre channel adapter. The second illustrates connections for workstations equipped with SGI and PCI single port fibre channel adapters.

NOTE: XR-series storage configurations are not available for the SGI Octane MXE.

**Octane MXE
with Dual Port FC Adapter**

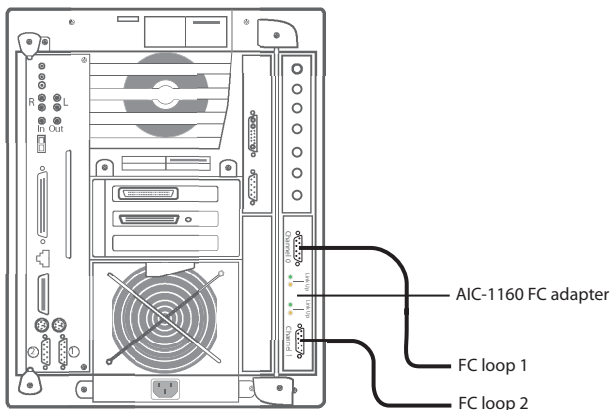

Octane MXE with Single Port FC Adapters

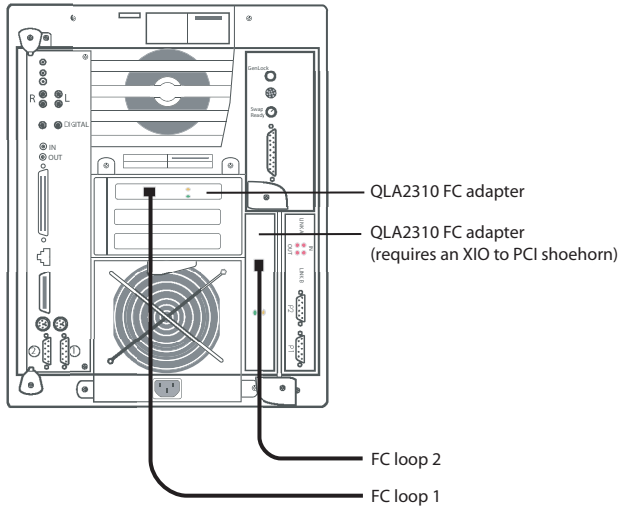

SGI Octane2

The diagrams in this section illustrate connections for the SGI Octane2 workstation. The first illustrates 2-loop connections for workstations equipped with SGI and PCI single port fibre channel adapters. The second illustrates 2-loop and 4-loop connections for workstations equipped with SGI and PCI dual port fibre channel adapters.

NOTE: XR-series storage configurations are not available for the SGI Octane2.

**Octane2
with Single Port FC Adapters**

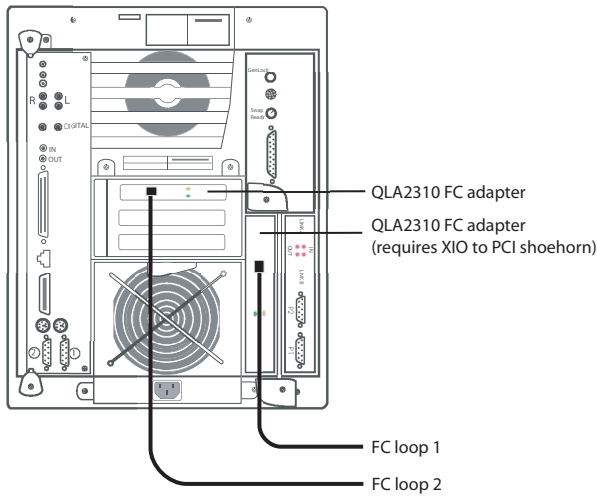

**Octane2
with Dual and Single Port FC Adapters**

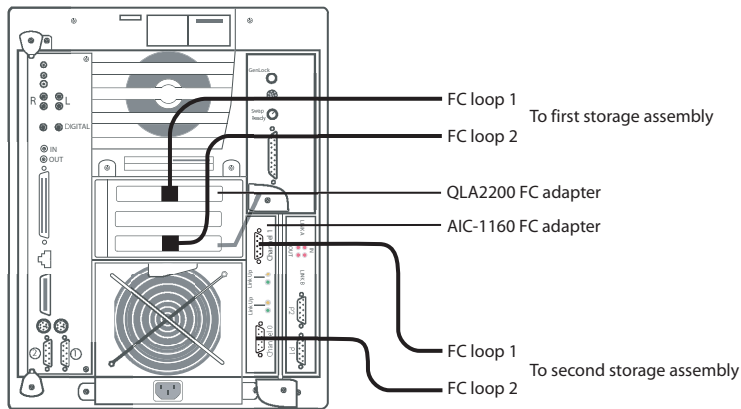

 **WARNING:** In the diagram immediately above, if your Octane 2 is equipped with QLA2342 FC adapters, do not connect both ports on the same adapter to storage; the individual PCI and XIO buses cannot support the full bandwidth of the QLA2342 FC adapter.

NOTE: In the diagram immediately above, the boards illustrated in the PCI card cage may vary from those in your system.

SGI Tezro

The diagram in this section illustrates 2-loop and 4-loop connections for the SGI Tezro workstation.

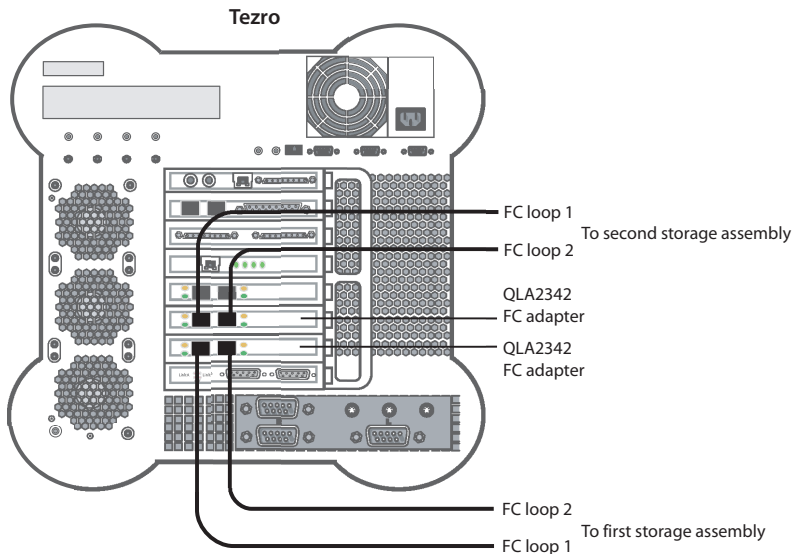

WARNING: Do not use the QLA2342 FC adapter in the slot above the two illustrated to connect to storage, as this would mean all four ports to storage share the same PCI bus. This would saturate the bus and reduce performance. Instead, use that adapter to connect to optical archiving devices or a Stone Shared Storage Area Network (SAN).

NOTE: If the number of ports in the fibre channel adapters in your workstation are not as shown in the diagram, refer to [“Cabling for 2- and 4-Port Fibre Channel Adapters”](#) on page 20 for help determining which ports to connect to storage. Also remember that any unused ports on a 4-port adapter should be terminated using FC loopback couplers.

SGI Onyx2

The diagrams in this section illustrate connections for the SGI Onyx 2 workstation. The first illustrates 2-loop and 4-loop connections for workstations equipped with dual port SGI fibre channel adapters. The second illustrates 2-loop connections for workstations equipped with single port PCI fibre channel adapters.

NOTE: XR-series storage configurations are not available for the SGI Onyx 2.

Onyx2 with Dual Port FC Adapters

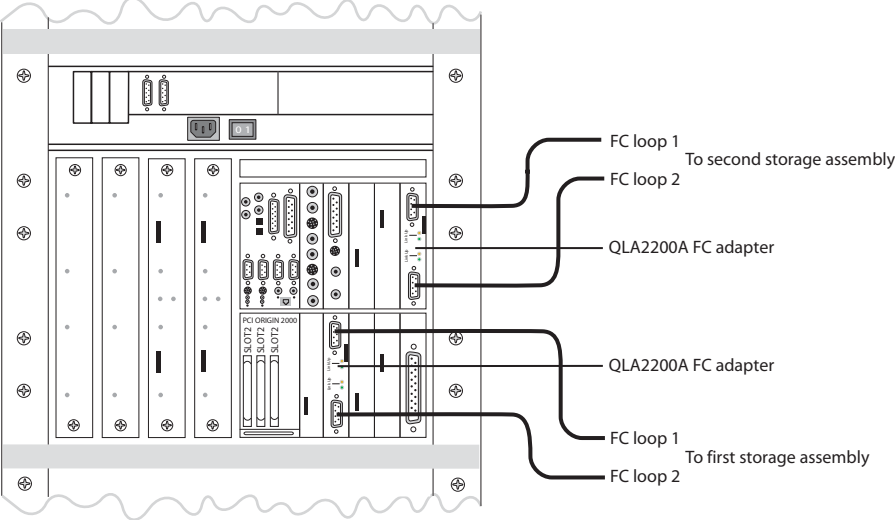

**Onyx2
with Single Port FC Adapters**

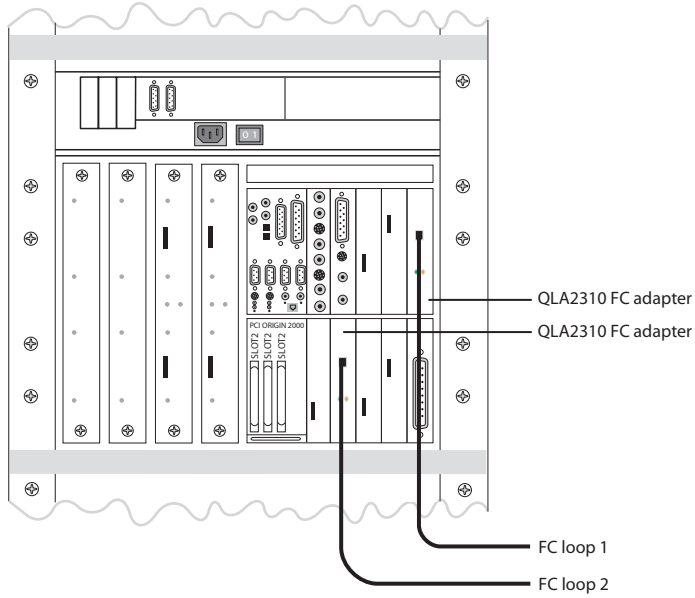

SGI Onyx 3200

The four diagrams in this section illustrate connections for the SGI Onyx 3200 workstation.

- The first illustrates 2- and 4-loop connections from the X-Brick. Although this diagram shows an IX-brick, the workstations may be equipped with either an IX-brick or I-brick.
- The second illustrates 2- and 4-loop connections for dual port fibre channel adapters in an IX-brick.
- The third illustrates 2-loop connections for workstations equipped with single port fibre channel adapters in an I-brick.
- The fourth illustrates 2-loop connections for a dual port fibre channel adapter in an I-brick and 4-loop connections for workstations equipped with dual port fibre channel adapters in an I-brick and an X-brick.

NOTE: XR-series storage configurations are not available for the SGI Onyx 3200.

**Onyx 3200
with Dual Port FC Adapters**

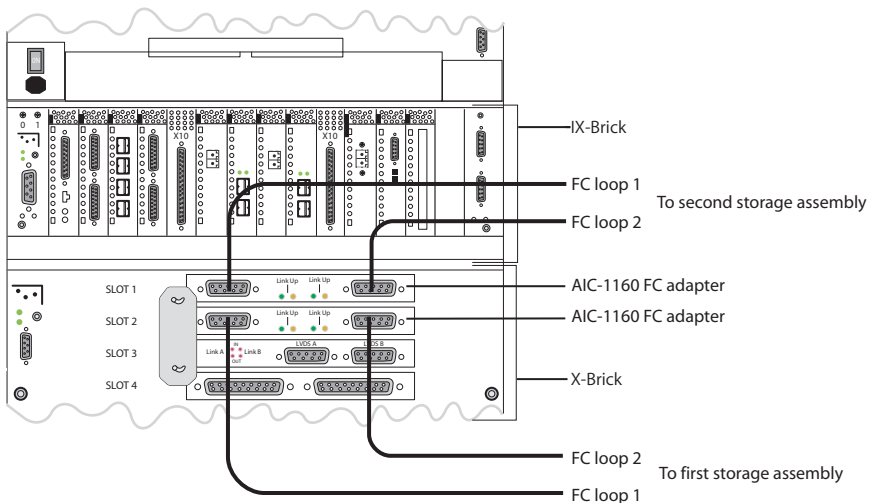

**Onyx 3200
with FC Adapters in IX-Brick**

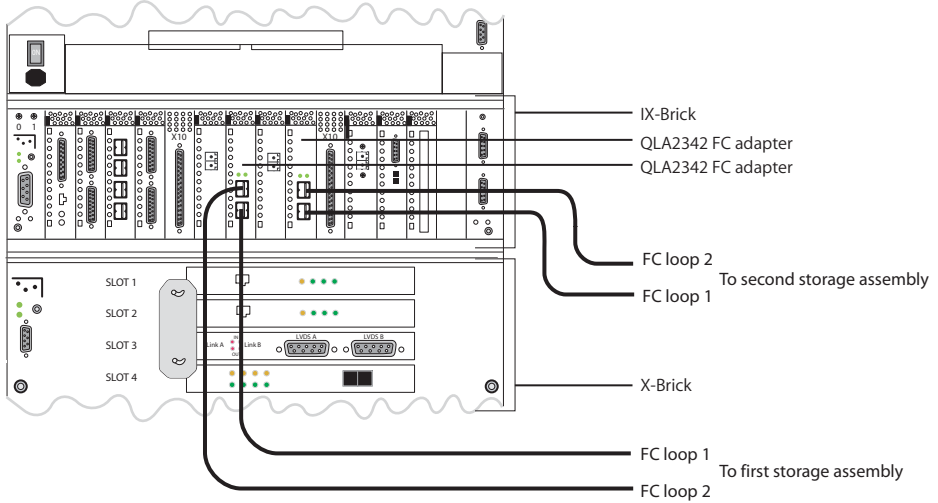

**Onyx 3200
with Single Port FC Adapters in I-Brick**

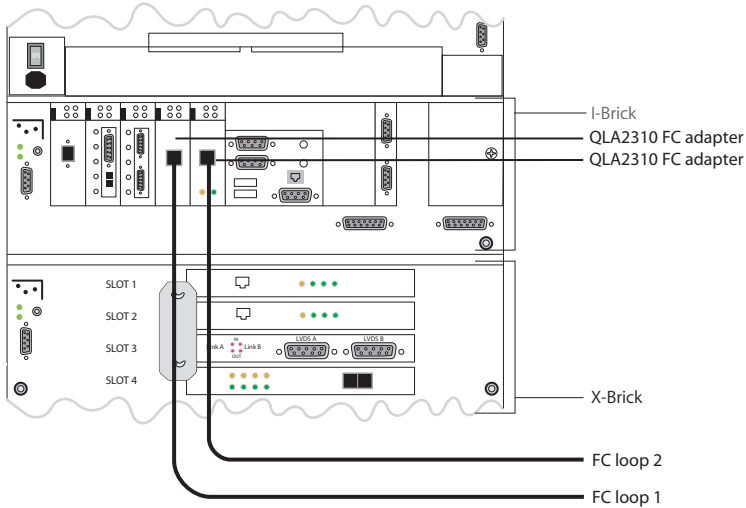

**Onyx 3200
with Dual Port FC Adapter in I-Brick and X-Brick**

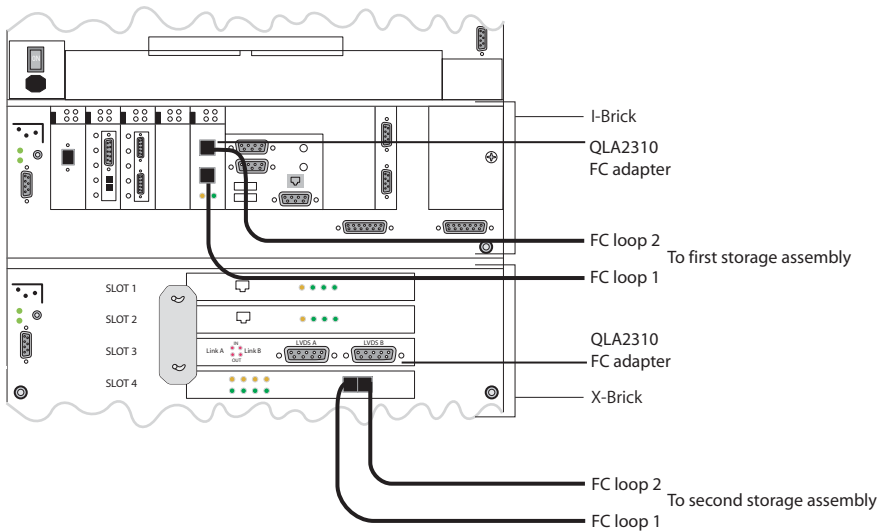

NOTE: If the number of ports in the fibre channel adapters in your workstation are not as shown in the diagram, refer to [“Cabling for 2- and 4-Port Fibre Channel Adapters”](#) on page 20 for help determining which ports to connect to storage. Also remember that any unused ports on a 4-port adapter should be terminated using FC loopback couplers.

SGI Onyx 350

The diagram in this section illustrates 2-loop and 4-loop connections for the SGI Onyx 350 workstation.

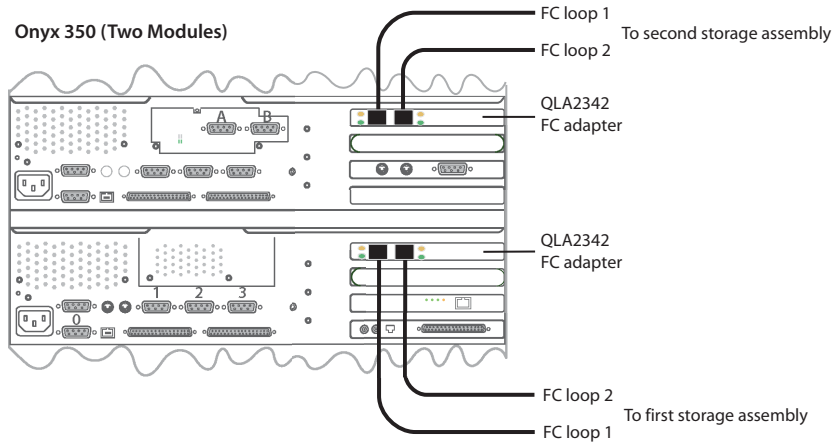

NOTE: If the number of ports in the fibre channel adapters in your workstation are not as shown in the diagram, refer to [“Cabling for 2- and 4-Port Fibre Channel Adapters”](#) on page 20 for help determining which ports to connect to storage. Also remember that any unused ports on a 4-port adapter should be terminated using FC loopback couplers.

Storage Connections

5

Summary

About 2-Loop and 4-Loop Configurations	43
XR-Series	44
IR-Series	47
Disconnecting and Reconnecting Storage	52

About 2-Loop and 4-Loop Configurations

Each workstation-to-storage fibre channel connection is referred to as a “loop”. Each Stone Direct storage enclosure can accommodate two loops. In a 2-loop configuration, you connect two fibre channel ports on your workstation to the two fibre channel connectors on a single storage enclosure. In a 4-loop configuration you connect four fibre channel ports on your workstation to two storage enclosures (two fibre channel connectors per enclosure). Depending on your storage configuration, you might daisy-chain additional enclosures to the ones directly connected to your workstation.

A storage assembly consists of the enclosure directly connected to your workstation, and any additional enclosures daisy-chained to that enclosure. A 2-loop configuration consists of one storage assembly. A 4-loop configuration consists of two storage assemblies.

The diagrams in this guide refer to “first” and “second” storage assembly. In a 2-loop configuration, “first” storage assembly refers to the only one in the configuration. In a 4-loop configuration, the “first” storage assembly is the one on the left of the diagram, and the “second” is the one on the right.

NOTE: It is important to cable exactly as illustrated in the diagrams and explained in the text to ensure storage functions properly. For example, do not reverse fibre channel connections for first and second enclosures, or reverse individual workstation-to-storage connections.

The following diagram summarizes the information in this section. Although it illustrates XR-series enclosures, the information applies to both XR- and IR-series configurations.

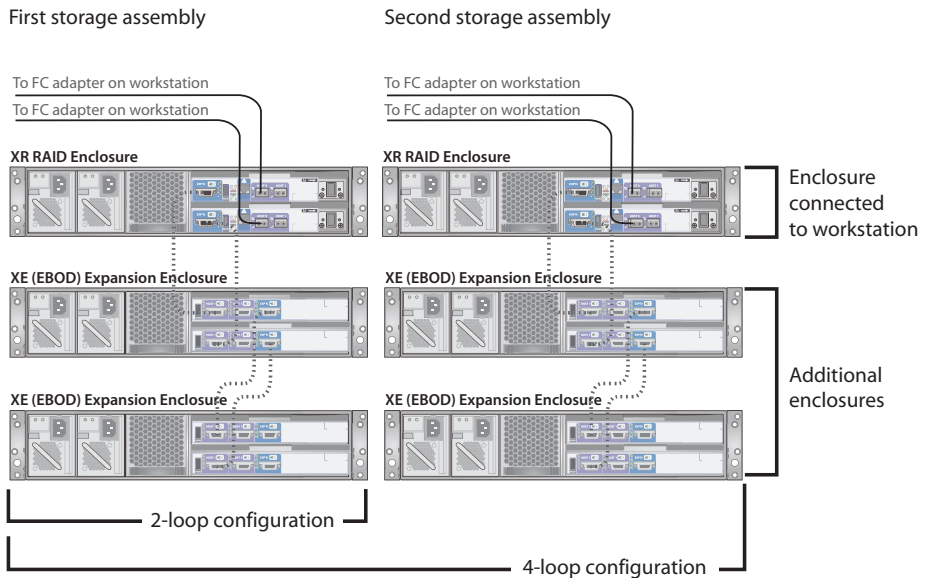

XR-Series

The XR-series provides both 2-loop and 4-loop hardware RAID configurations.

2-Loop Hardware RAID Configurations

This diagram illustrates how to cable a 2-loop hardware RAID storage configuration. Solid lines represent cabling for the simplest 2-loop configuration (a single RAID enclosure). Dotted lines represent cabling for additional enclosures (up to four EBOD enclosures). The table below the diagram lists the hardware you need to cable different sizes of this storage configuration.

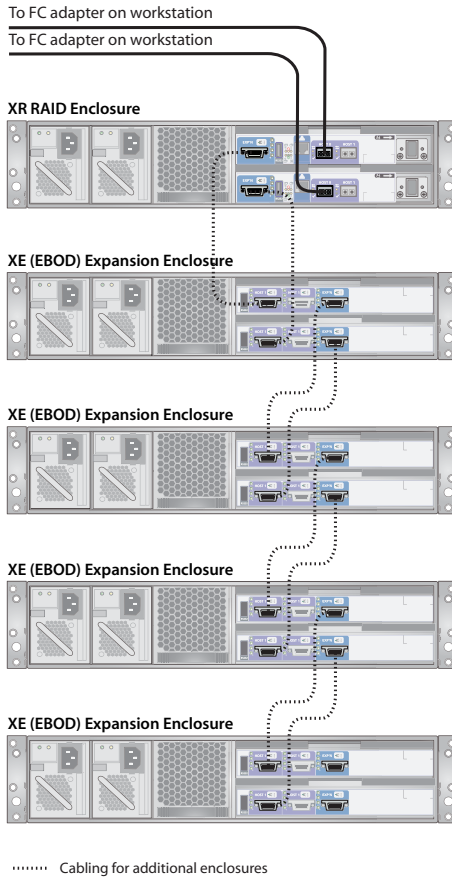

NOTE: A 2-loop configuration supports a maximum of four expansion enclosures.

Number of RAID Units	Number of XE (EBOD) Expansion Units	Number of fibre optic LC cables	Number of SFP transceiver modules LC	Number of SFP 0.5 m inter-chassis cables
1	0	2	2	0
1	1	2	2	2
1	2	2	2	4
1	3	2	2	6
1	4	2	2	8

NOTE: 4 Gb storage configurations require 4 Gb SFP transceivers. A label on 4 Gb SFP transceivers differentiates them from 2 Gb transceivers (which do not have labels).

4-Loop Hardware RAID Configurations

These diagrams illustrate how to cable enclosures in a 4-loop hardware RAID storage configuration. The first illustrates the cabling for all 4-loop configurations *except* Lustre running under Linux on the IBM 6223 workstation. The second illustrates the 4-loop configuration for Lustre running under Linux on the IBM 6223 workstation.

In the diagrams, solid lines represent cabling for the simplest 4-loop configuration and dotted lines represent cabling for additional enclosures. In 4-loop configurations with two storage assemblies (the configuration illustrated in the first diagram), you can have either two or four additional enclosures.

The table below the diagrams lists the hardware you need to cable different sizes of this storage configuration.

First storage assembly

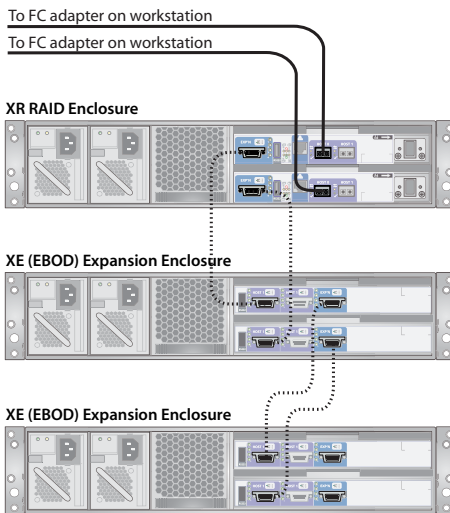

Second storage assembly

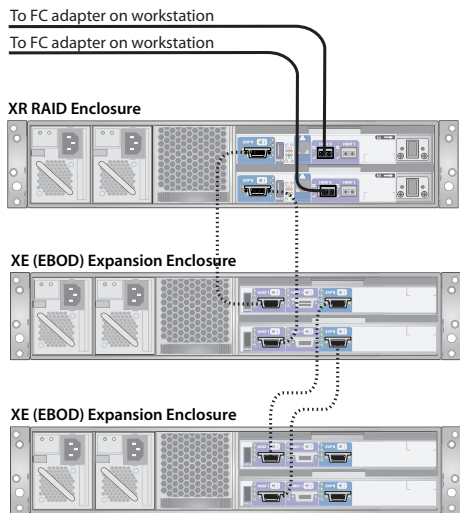

..... Cabling for additional enclosures

NOTE: A 4-loop configuration for Effects or Editing systems supports a maximum of two expansion enclosures per RAID controller. A 4-loop configuration for Lustre (Windows) or Incinerator supports a maximum of four expansion enclosures per RAID controllers.

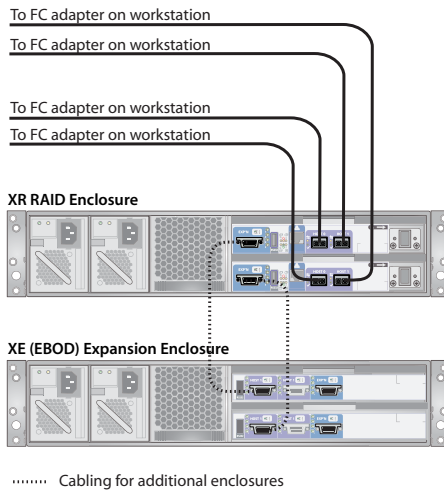

Number of RAID Units	Number of XE (EBOD) Expansion Units	Number of fibre optic LC cables	Number of SFP transceiver modules LC	Number of SFP 0.5 m inter-chassis cables
2	0	4	4	0
2	2	4	4	2
2	4	4	4	4

NOTE: 4 Gb storage configurations require 4 Gb SFP transceivers. A 4 Gb SFP transceiver is differentiated from a 2 Gb transceiver by its label, which is not present on the 2 Gb transceiver.

IR-Series

The IR-series provides both 2-loop and 4-loop software RAID configurations, and 2-loop and 4-loop hardware RAID configurations. Software RAID configurations use only JBOD storage arrays. Hardware RAID configurations use RAID units, and depending on the configuration, may use JBOD RAID expansion units to provide additional storage.

NOTE: Software RAID configurations are not available for Linux systems.

NOTE: If you want to use 720p video resolution on HD configurations, you must use 15k drives. You cannot use 720p with 10k drives.

The way you cable enclosures together depends on whether you are using hardware or software RAID. In a software RAID configuration, you cross cables between I/O modules to make the number of drives on each channel equal and ensure balanced throughput among all channels. Each enclosure contains 15 drives and two internal buses. One bus connects all odd-numbered

drives and the other connects all even-numbered drives (since numbering starts from 0, there are seven odd-numbered drives and eight even-numbered drives). By crossing the cables between I/O modules, you create channels that contain an equal amount of drives.

In a hardware RAID configuration this cross-cabling is not necessary; the hardware RAID controller manages the number of drives in each channel.

NOTE: There are two types of JBOD enclosures. One is a simple JBOD enclosure, which is used in software RAID configurations. The other is a JBOD RAID expansion enclosure, which can only be used in hardware RAID configurations. Both types cannot be interchanged.

2-Loop Software RAID Configurations (JBOD Only)

This diagram illustrates how to cable a 2-loop software RAID storage configuration. Solid lines represent cabling for the simplest 2-loop configuration (a single software RAID JBOD enclosure). Dotted lines represent cabling for additional enclosures (one to five software RAID JBOD enclosures). The table below the diagram lists the hardware you need to cable different sizes of this storage configuration.

NOTE: A 2-loop, 2 Gb configuration with a single JBOD chassis does not support the 720p 60 format. This format requires a minimum of two JBOD chassis.

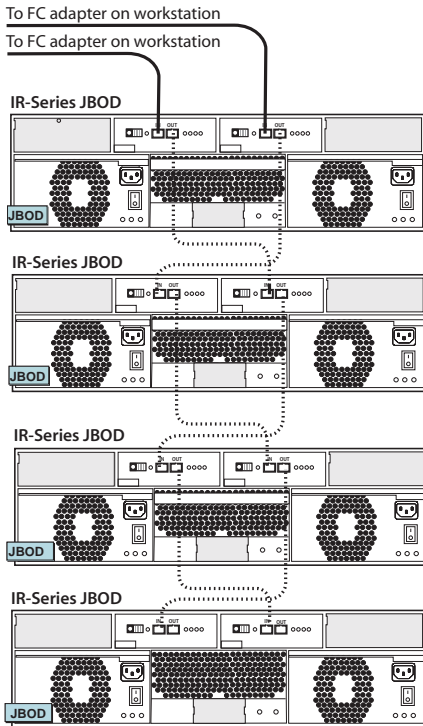

..... Cabling for additional enclosures

Number of JBOD Units	Number of fibre optic LC cables	Number of SFP transceiver modules LC	Number of SFP 0.5 m inter-chassis cables
1	2	2	0
2	2	2	2
4	2	2	4

4-Loop Software RAID Configurations

This diagram illustrates how to cable a 4-loop software RAID storage configuration. Solid lines represent cabling for the simplest 4-loop configuration (two software RAID JBOD enclosures). Dotted lines represent cabling for additional enclosures (two to six software RAID JBOD enclosures). The table below the diagram lists the hardware you need to cable different sizes of this storage configuration.

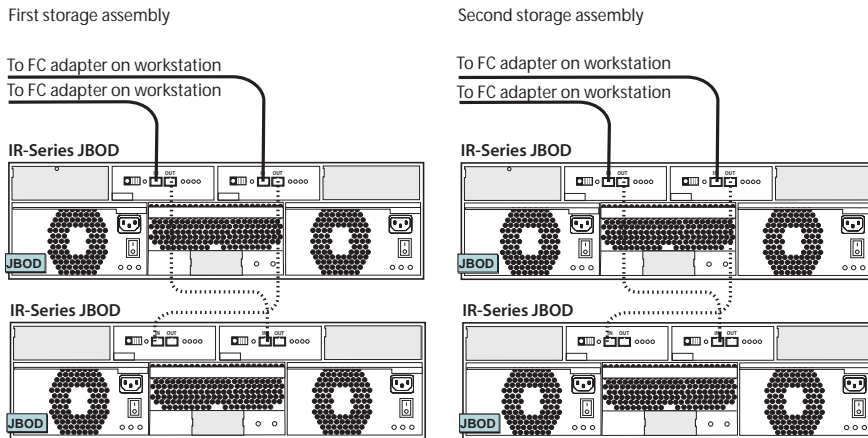

..... Cabling for additional enclosures

Number of JBOD Units	Number of SFP to DB9 cables	Number of SFP to HSSDC cables	Number of SFP 0.5 m inter-chassis cables
2	2	2	0
4	2	2	4

2-Loop Hardware RAID Configurations

This diagram illustrates how to cable a 2-loop hardware RAID storage configuration. Solid lines represent cabling for the simplest 2-loop configuration (a single RAID enclosure). Dotted lines represent cabling for additional enclosures (one to five hardware RAID JBOD expansion enclosures). The table below the diagram lists the hardware you need to cable different sizes of this storage configuration.

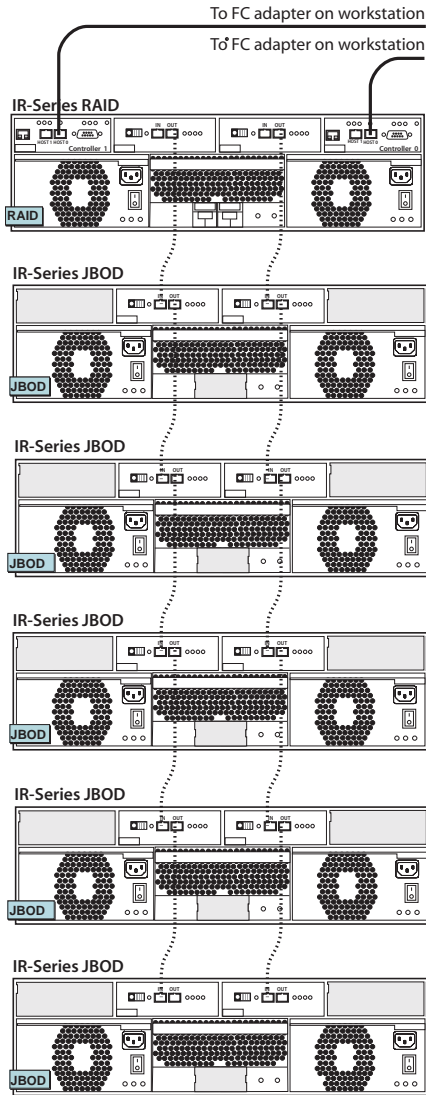

..... Cabling for additional enclosures

Number of RAID Units	Number of JBOD Expansion Units	Number of fibre optic LC cables	Number of SFP transceiver modules LC	Number of SFP 0.5 m inter-chassis cables
1	1	2	2	2
1	3	2	2	6
1	5	2	2	8

4-Loop Hardware RAID Configurations

This diagram illustrates how to cable a 4-loop hardware RAID storage configuration. Solid lines represent cabling for the simplest 4-loop configuration (two RAID enclosure). Dotted lines represent cabling for additional enclosures (two to four hardware RAID JBOD expansion enclosures). The table below the diagram lists the hardware you need to cable different sizes of this storage configuration.

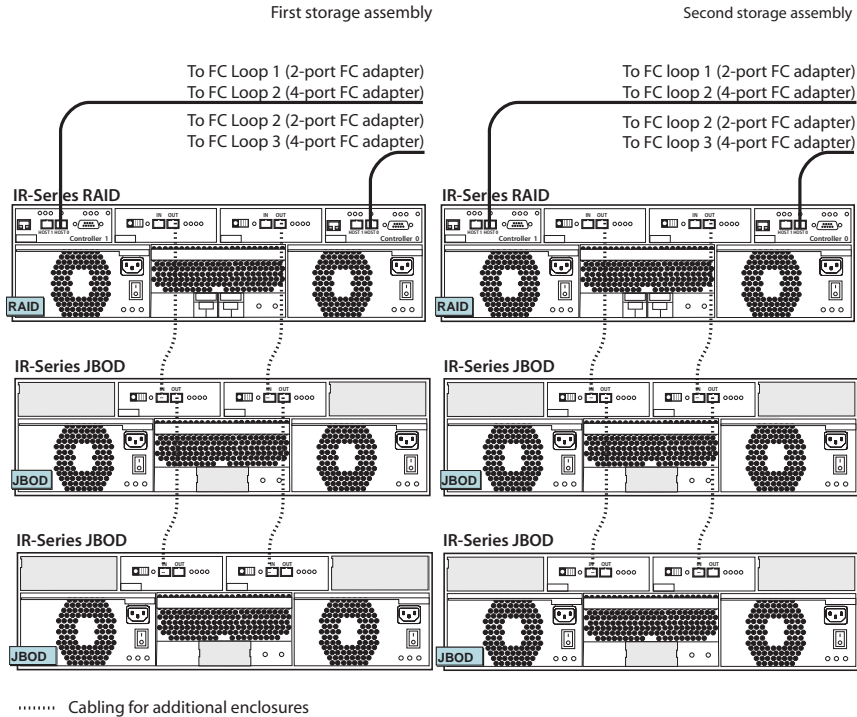

Number of RAID Units	Number of JBOD Expansion Units	Number of fibre optic LC cables	Number of SFP transceiver modules LC	Number of SFP 0.5 m inter-chassis cables
2	0	4	4	0
2	2	4	4	4
2	4	4	4	8

Disconnecting and Reconnecting Storage

After you configure your storage, you must ensure cable connections do not change. If you must disconnect storage at any time, be sure to note which cables connect to which ports prior to disconnecting the cables so that you can re-establish the correct connections.



Internal Storage Connections

Summary

[About Internal Storage](#) 53
[IBM 6217 SC](#) 54

About Internal Storage

This chapter describes how to connect internal storage on workstations that support internal storage. Only Autodesk-supplied hard disks can be used for internal storage.



WARNING: Connecting internal storage requires work inside the workstation enclosure. Wear a grounding strap to ensure you do not inadvertently damage components as you work inside the enclosure. Also, Internal drives require adequate ventilation, always ensure that the workstation's side cover is closed before you boot the workstation.

I/O and Playback Limitations

The following limitations apply to internal storage configurations.

Platform	I/O	Playback Limitation
IBM 6217 SC	SD	Single-stream SD only (no cross-dissolve in Autodesk Smoke®)

Setting Up Internal Storage

After you install your Effects or Editing application on the workstation, use the Stone and Wire *sw_config* utility to set up the Stone filesystem and manage the internal storage on the workstation. For information about this utility, see the *Stone and Wire Filesystem and Networking Guide* for your release.

Protecting Data on Internal Storage

You normally protect data on a Stone filesystem using software or hardware RAID. However, these features are not available for workstations using the internal storage configuration.

Because disk failure may result in media loss, do the following to protect media while working on the workstation:

- Do not store critical or long-term projects on the internal storage of the workstation.
- Ensure media used in projects is backed up and can be recaptured, if necessary.
- Save projects and project archives to a network drive that is backed up on a regular basis.

IBM 6217 SC

Internal storage on the IBM 6217 SC workstation is available only for the SD configuration. The internal storage configuration uses four 300 GB Ultra 320 SCSI storage disks inside the system enclosure. These disks are connected to a SCSI adapter separate from the system disk. The system disk is a Serial Advanced Technology Attachment (SATA) disk.

Each hard disk used for internal storage must have a unique SCSI identification number. This number is set using jumpers on the hard disk. If you replace a hard disk in internal storage, refer to its documentation to give the disk a unique SCSI identification number using its jumpers.

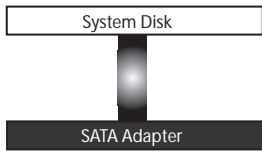

Ultra SCSI 320 Adapter 1:
-2 data drives
-300 GB each

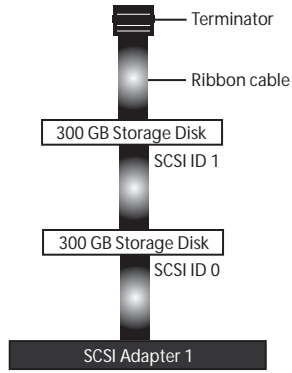

Ultra SCSI 320 Adapter 2:
-2 data drives
-300 GB each

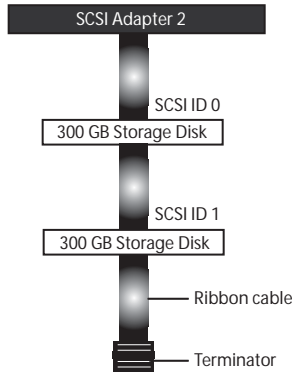

LUN Management Guidelines

Summary

About LUN Configuration	57
Certified LUN Configurations	59
Mounting the Storage CD on a Linux Workstation	59
Accessing the RAID Controllers	59
XR-Series LUN Creation Using the XR Configuration Utility	62
XR-Series LUN Creation and Management Using the SSM Utility	65
XR-Series LUN Mapping for Red Hat 3 Linux	73
XR-Series LUN Mapping for Lustre Under Red Hat 3 Linux	78
IR-Series LUN Creation and Management Using DSM	89

About LUN Configuration

The first step in connecting new storage to your workstation is to configure logical volumes (LUNs). For LUN configuration procedures refer to, [“Configuring LUNs on XR-Series Storage”](#) on page 57 or [“Configuring LUNs on IR-Series Storage”](#) on page 58.

Once the LUNs are created and configured, you must create a filesystem on your storage. For Effects or Editing workstations, refer to the *Stone and Wire Filesystem and Networking User’s Guide*. For Lustre or Incinerator workstations refer to, *Lustre Software Installation Guide*.

Configuring LUNs on XR-Series Storage

You must configure logical volumes (LUNs) on XR-series storage RAID controllers prior to initial use.

This chapter provides LUN creation and management guidelines for:

- Effects or Editing systems using XR-series storage with a Linux workstation under Red Hat® Enterprise Linux® WS 4, Update 2 or 3, or Lustre systems running under Windows XP SP1 that are using a 4-loop, single XR-RAID enclosure (with or without an additional XR EBOD

enclosure) storage configuration. See [“XR-Series LUN Creation Using the XR Configuration Utility”](#) on page 62.

- Effects or Editing Systems using XR-series storage with a Linux workstation under Red Hat® Enterprise Linux® WS 3, Update 5 or earlier. Refer to, [“XR-Series LUN Creation and Management Using the SSM Utility”](#) on page 65 and [“XR-Series LUN Mapping for Red Hat 3 Linux”](#) on page 73.
- Lustre systems under Red Hat® Enterprise Linux® WS 3, Update 5 or earlier, that are using a 4-loop, single XR-RAID enclosure (with or without an additional XR EBOD enclosure) storage configuration. In this case you *must* map logical drive numbers to fibre channel adapter ports prior to mounting and creating the filesystem on the workstation. Failure to do so will result in the operating system detecting only a portion of the available storage. Refer to, [“Creating LUNs on a 4-Loop Single XR-RAID Lustre Configuration”](#) on page 69 and [“XR-Series LUN Mapping for Lustre Under Red Hat 3 Linux”](#) on page 78.
- Existing systems using XR-series storage under Red Hat® Enterprise Linux® WS 3, Update 5 or earlier, that are doing any of the following: connecting the workstation to XR-series storage for the first time, replacing the fibre channel adapter on a workstation that was already connected to XR-series storage, or reorganizing individual workstation-to-storage connections. In all of these cases you *must* map logical drive numbers to fibre channel adapter ports prior to mounting and creating the filesystem on the workstation. Failure to do so will result in the operating system detecting only a portion of the available storage.

For Lustre workstations, refer to [“Creating LUNs on a 4-Loop Single XR-RAID Lustre Configuration”](#) on page 69 and [“XR-Series LUN Mapping for Lustre Under Red Hat 3 Linux”](#) on page 78.

For Editing or Effects workstations, refer to [“XR-Series LUN Creation and Management Using the SSM Utility”](#) on page 65 and [“XR-Series LUN Mapping for Red Hat 3 Linux”](#) on page 73.

Configuring LUNs on IR-Series Storage

All IR-series storage RAID controllers are pre-configured with LUNs and ready to connect to your Effects or Editing workstation. All you need to do is mount the storage and create the Stone filesystem. Consult the *Stone and Wire Filesystem and Networking User’s Guide* for more information.

Should you need to re-configure LUNs on your IR-series storage, refer to [“IR-Series LUN Creation and Management Using DSM”](#) on page 89. If you require more detailed procedures than those provided in this chapter, refer to the *Discreet Storage Manager Installation and User’s Guide, 3rd Edition*.

All procedures in this chapter assume you have connected your storage as illustrated in the *Workstation Connections* and *Storage Connections* chapters of this guide.



WARNING: The only case in which LUN configuration is *not* destructive is if it recreates a layout that is identical to the existing one.

Certified LUN Configurations

RAID configurations are designed and tested by Autodesk to provide optimal performance for media playback on your workstation. Although the RAID management utilities (Stone Storage Manager for the XR-series, and Discreet Storage Manager for the IR-series) let you customize LUN configuration manually, deviating from the documented LUN configuration processes contained in the chapter is not supported.

Mounting the Storage CD on a Linux Workstation

To access the contents of the Storage CD, you must have access to a mounted CD-ROM drive.

To mount a CD-ROM drive:

1. Insert a CD into the CD-ROM drive.
2. Log in as root.
3. Access the content of the CD-ROM. in a terminal, type:

```
mount /mnt/cdrom
```

To verify the CD-ROM drive is mounted:

1. Log in as root.
2. Type:

```
df -k
```

You should see **/dev/cdrom** appear in the system response. If **/dev/cdrom** does not appear, the drive is not mounted.

Accessing the RAID Controllers

If your RAID controller is already connected and configured on your local network, you can launch the Stone Storage Manager RAID management utility by pointing a Web browser (Internet Explorer, Firefox, etc.) to *http://<ip address>:9292*.

If your RAID controller is not yet connected and configured on your local network, see [“Connecting to the RAID Controller for the First Time”](#) on page 60.

Connecting to the RAID Controller for the First Time

Before you can connect to the RAID controller on your local network for the first time, you must set or change its IP address. Each of the two RAID controllers in an XR RAID enclosure has its own IP address; you can configure LUNs by connecting to either of the two. The factory default IP address of RAID controller 0 (the bottom controller) is 10.1.1.5. For RAID controller 1 (the bottom controller) the factory default IP address is 10.1.1.6.

Connect the second Ethernet port on your workstation to the Ethernet port of RAID controller 0 (you may require a twisted pair cat5 cable).

Then set the second Ethernet interface on your workstation to 10.1.1.x.

Launch the Stone Storage Manager RAID management utility by pointing a Web browser at the IP address of the RAID controller, from your workstation. For example:

```
firefox http://10.1.1.5:9292.
```

Setting the IP Address of the Controller

Once you are in Stone Storage Manager, you can change its IP address to one that is consistent with your local network.

To set the IP address of the controller:

- 1. In the Stone Storage Manager, click Settings.

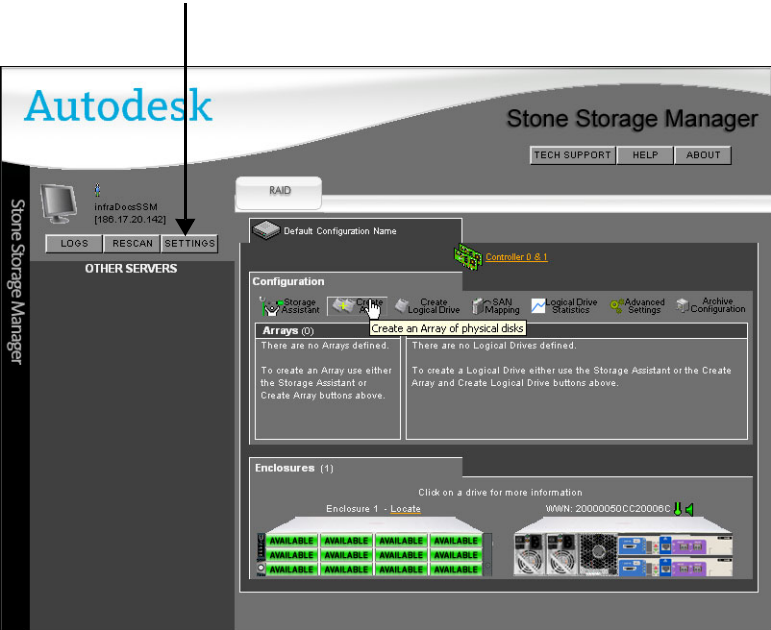

- 2. Select the Preferences tab.

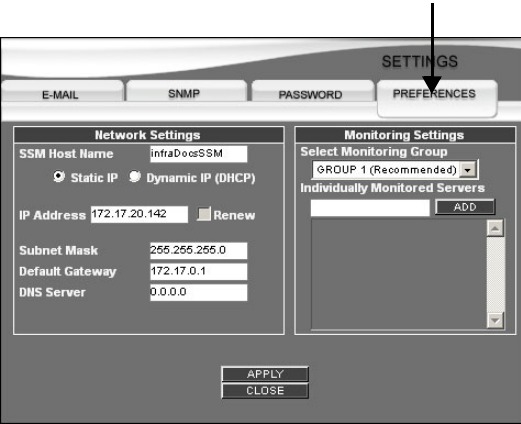

- 3. Enter hostname and IP information and click APPLY.

XR-Series LUN Creation Using the XR Configuration Utility

To create the LUNs on your XR-series storage, you must use the XR configuration utility that automates the LUN creation process.

Although XR-series LUN creation is now performed by the XR configuration utility, you should monitor the LUN creation process by accessing the RAID controllers and launching the Stone Storage Manager (SSM) RAID management utility. To launch SSM, refer to [“Accessing the RAID Controllers”](#) on page 59.

The XR configuration utility will exit without configuring your storage if any of the following pre-requisites are not met:

- Each enclosure must be fully populated with 12 disk drives.
- Each enclosure must have the correct firmware.
- In a dual RAID enclosure environment, both enclosures must be connected to an equal number of expansion enclosures.

 **WARNING:** If any of these pre-requisites are not met, the XR configuration utility exits and displays the following message:

```
Cannot create a sufficient number of arrays.
```

Configuring LUNs with the XR Configuration Utility

The procedure in this section configures LUNs on XR-series storage for the following systems:

Filesystem	Application(s)	Platform
Stone FS	Autodesk Inferno, Flame, Flint, Fire, Smoke 2007.0.1	Linux
XFS	Autodesk Lustre Incinerator LMS/AMS 2007.0.1	Linux
XFS	Autodesk Lustre 2007.0.1 (stand alone)	Linux
NTFS	Autodesk Lustre 2007.0.1	Windows

To configure LUNs on XR-series storage:

1. Insert the Storage CD into the Workstation's Drive.
2. Open a command line interface:
 - On a Linux system, open a Terminal.
 - On a Windows system, open a Command Prompt.
3. On a Linux system, mount the storage CD, refer to [“Mounting the Storage CD on a Linux Workstation”](#) on page 59.

 **WARNING:** If you copy the utility to the local host, you must also copy the *lib_a* and *exe* directories along with it.

- In the Terminal or Command Prompt, launch the LUN configuration utility.
On Linux, go to the `/XR_configuration/Linux_config_tools` directory on the storage CD and type:

```
./XR_config
```

On Windows, go to the `\XR_configuration\Windows_config_tools` directory on the storage CD and type:

```
XR_config.exe
```

The script determines the operating system of the workstation on which it is running and detects whether a LUN configuration exists on the storage attached to that workstation.

- If a LUN configuration already exists on the storage, you are prompted for confirmation to overwrite that configuration.



WARNING: LUN configuration is destructive. Make sure you want to overwrite an existing configuration before you confirm.

- After the script detects the number of enclosures and drives, it prompts you to indicate the filesystem your storage configuration uses. Use the following table to determine the number to enter.

Enter:	To select:
0	Clear Configuration
1	Stone FS for an Effects or Editing Workstation
2	Stone FS for an Effects or Editing Workstation with CXFS SAN Access
3	XFS for an Incinerator Lustre Media Server
4	XFS for Lustre Linux Workstation
5	NTFS for Windows
6	Exit Configuration Utility

NOTE: If you choose a filesystem that is incompatible with your storage configuration, the script cautions you that this is the case and prompts for confirmation to continue.

Sample LUN Configuration Session

The following is a sample session for configuring LUNs on a 2-loop Lustre Windows system. Text in bold indicates user input.

```
\XR_configuration\Windows_config_tools\XR_config.exe
```

```
===> This is Windows Operation System
```

```
*** An existing configuration has been detected. This
*** configuration will be overwritten by this utility if it
*** proceeds.
```

```
Would you like to continue? [Y/N]: y
```

```
Found 1 enclosure(s).
```

```
Found 12 drives.
```

```
Please select the desired filesystem to be used:
```

```
0) Clear Configuration
```

```
1) Stone FS for an Effects or Editing Workstation
```

```
2) Stone FS for an Effects or Editing Workstation with CXFS SAN
Access
```

```
3) XFS for an Lustre Media Server
```

```
4) XFS for a Lustre Linux Workstation
```

```
5) NTFS for Windows
```

```
6) Exit Configuration Utility
```

```
> 5
```

```
Clearing the configuration... Done!
```

```
Creating arrays for enclosure 1... Done!
```

```
Applying cache settings.
```

```
Creating logical device on array 0... Done!
```

```
Assigning logical device 0 to c0p0.
```

```
Creating logical device on array 1... Done!
```

```
Assigning logical device 1 to c1p0.
```

```
Assigning system parameters.
```

The XR configuration utility will exit without configuring your storage if any of the following parameters are detected:

- An incorrect number of disks. The total number of disks must be a multiple of 12.
- An incorrect version of RAID firmware.
- In a dual RAID enclosure environment, there must be an equal number of expansion chassis on each RAID enclosure. If a configuration with an uneven number of expansion chassis is

required (not supported) the script can be run once for each RAID enclosure. This would have to be done with a single RAID enclosure connected at a time.

If the XR configuration utility encounters any of these parameters, it will try 4 consecutive attempts to configure your storage, then exit and display the following message on the screen:

```
Cannot create a sufficient number of arrays.
```

Rescanning New LUNs from the Host Operating System

Newly-created LUNs must be rescanned by the host operating system to associate the proper disk devices with each LUN.

To rescan LUNs:

1. Reboot the system.
2. Verify the new LUNs were detected:
 - On Linux, examine the content of the file `/proc/scsi/scsi`.
 - On IRIX, type the following command and examine the output:

```
hinv
```

XR-Series LUN Creation and Management Using the SSM Utility

To create or manage the LUNs on your XR-series storage, access the RAID controllers using the Stone Storage Manager (SSM) utility provided with your storage configuration. See [“Accessing the RAID Controllers”](#) on page 59. Refer to the *Autodesk Stone Direct 2007 Storage Manager User’s Guide* guide for detailed descriptions and procedures.

Creating the LUNs

Each enclosure in an XR-Series storage configuration has the same LUN configuration. The procedure in this section describes how to create a LUN configuration for a single RAID enclosure. If you have a 4-loop configuration with a second RAID enclosure, repeat the procedure for the second RAID enclosure.

If you have a 4-loop, single XR-RAID enclosure storage configuration, use the procedure in [“Creating LUNs on a 4-Loop Single XR-RAID Lustre Configuration”](#) on page 69 instead of the one in this section to create the LUNs.

NOTE: You use the same procedure whether you are creating a LUN on a brand-new enclosure, or recovering a LUN configuration on an enclosure that previously had a LUN configuration. The only

difference between the two cases is that in the first you also initialize the disk array during the procedure. Note that you can write to the disk during the initialization process.

To create a LUN on an XR-series storage configuration:

1. Connect to Stone Storage Manager.
2. In Stone Storage Manager, click Create Array.

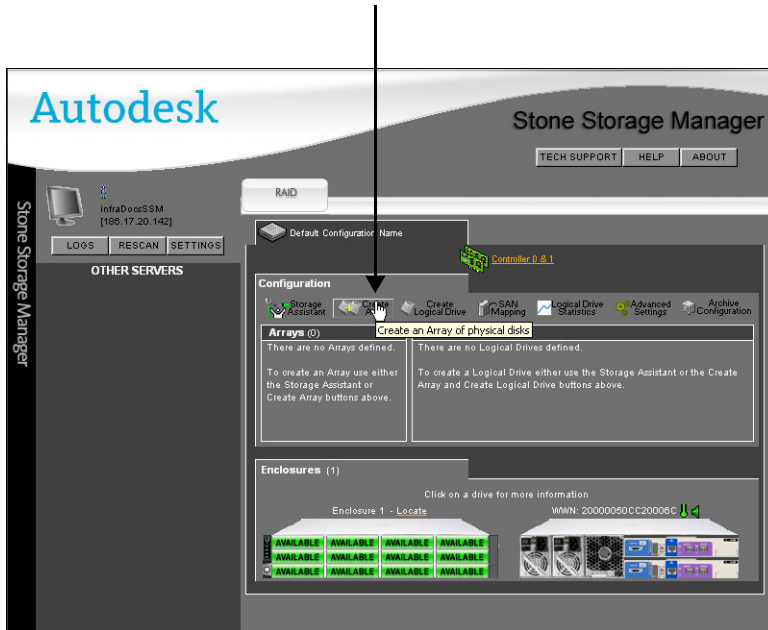

- In the Create Array panel that appears, select the drives for the first disk array.

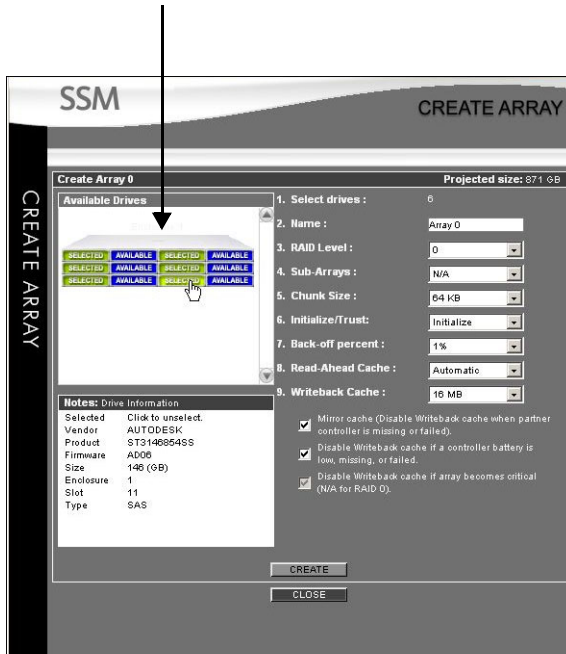

- Adjust the following settings to the values listed.

Setting:	Value:
RAID Level	5
Chunk Size	256
Mirror Cache	Disabled
Initialize/Trust	Initialize Newly created LUNs must undergo an initialization which is performed in the background. During this initialization, storage is available but performance may be slightly degraded for the duration of the initialization. NOTE: Never select Trust Array.

- Click Create.
- Repeat steps 3 through 5 to create the remaining drives.
- Click Close.

- In Stone Storage Manager, click Create Logical Drive.

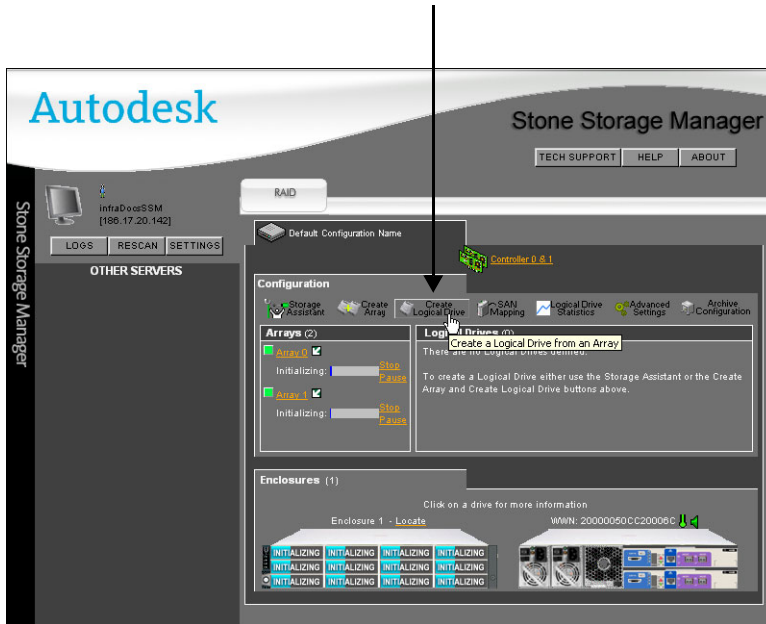

The Create Logical Drive panel appears.

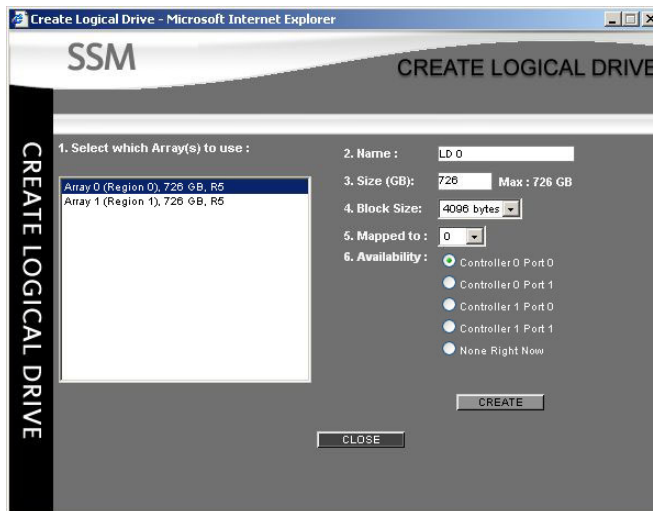

- In the Create Logical Drive panel, adjust the following settings to the values listed to create the LUN on RAID controller 0.

Setting:	Value:
Select arrays to use	Array 0
Block size	4096 for Effects and Editing workstations (IRIX and Linux) 512 for Lustre workstations (Linux and Windows) NOTE: The block size you define here is unrelated to the allocation unit size you define when you set up a stripe set for Lustre Windows.
Availability	Select Controller 0 Port 0

- In the Create Logical Drive panel, adjust the following settings to the values listed to create the LUN on RAID controller 1.

Setting:	Value:
Select arrays to use	Array 1
Block size	4096 for Effects and Editing workstations (IRIX and Linux) 512 for Lustre workstations (Linux and Windows) NOTE: The block size you define here is unrelated to the allocation unit size you define when you set up a stripe set for Lustre Windows.
Availability	Select Controller 1 Port 0

- Click Close.

- Repeat this procedure for each RAID enclosure.

Creating LUNs on a 4-Loop Single XR-RAID Lustre Configuration

Each enclosure in an XR-Series storage configuration has the same LUN configuration. The procedure in this section describes how to create a LUN configuration for a 4-loop, single RAID enclosure, with or without one additional XR EBOD enclosure.

NOTE: You use the same procedure whether you are creating a LUN on a brand-new enclosure, or recovering a LUN configuration on an enclosure that previously had a LUN configuration. The only difference between the two cases is that in the first you also initialize the disk array during the procedure. Note that you can write to the disk during the initialization process.

To create a LUN on an XR-series storage configuration:

1. Connect to Stone Storage Manager.
2. In Stone Storage Manager, click Create Array.

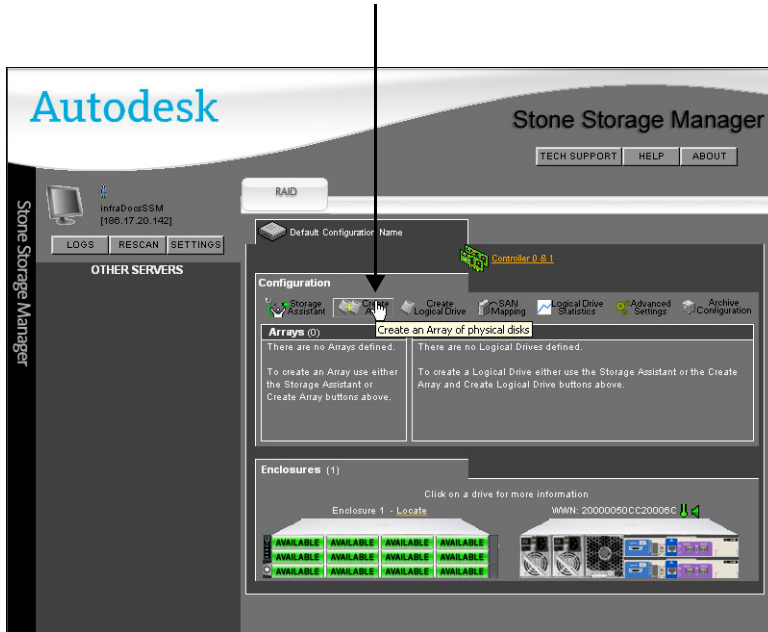

- In the Create Array panel that appears, select the drives for the first disk array.

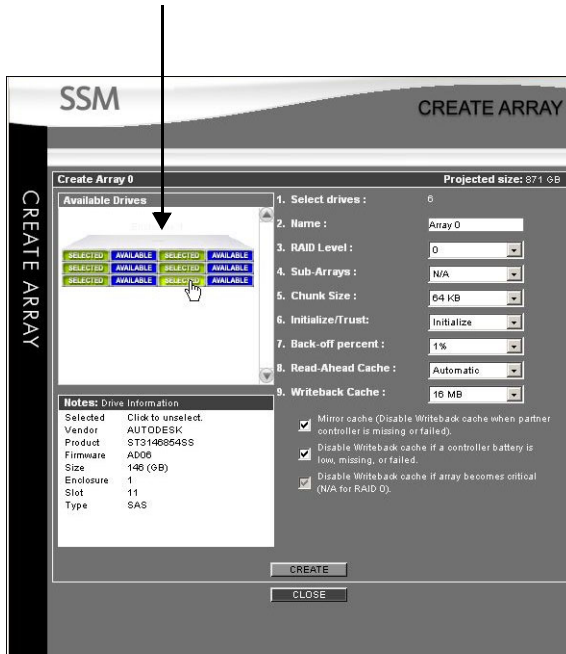

- Adjust the following settings to the values listed.

Setting:	Value:
RAID Level	5
Chunk Size	256
Mirror Cache	Disabled
Initialize/Trust	Initialize Newly created LUNs must undergo an initialization which is performed in the background. During this initialization, storage is available but performance may be slightly degraded for the duration of the initialization. NOTE: Never select Trust Array.

- Click Create.
- Repeat steps 3 through 5 to create the remaining drives.
- Click Close.

- In Stone Storage Manager, click Create Logical Drive.

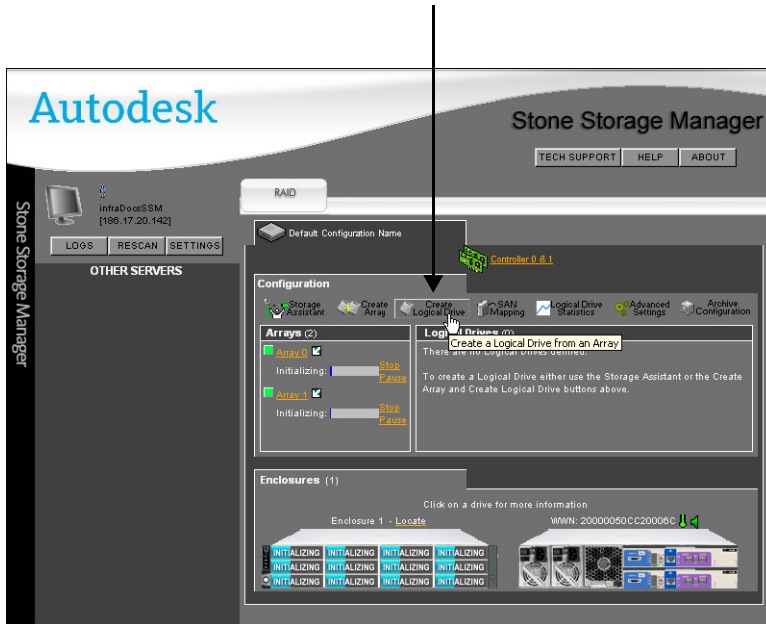

The Create Logical Drive panel appears.

- In the Create Logical Drive panel, create the logical drives as follows:
 - In the Select arrays to use area, select an array.
 - Adjust the settings for the LUN, as specified in the tables below.
 - Click Create.

NOTE: The Block Size field is unrelated to the allocation unit size you define when you set up a stripe set for Lustre Windows.

Array 0, LUN 0

Setting:	Value:
Select arrays to use	Array 0
Size (GB)	363
Block size	512
Availability	Controller 0 Port 0

Array 0, LUN 1

Setting:	Value:
Select arrays to use	Array 0
Size (GB)	363
Block size	512
Availability	Controller 0 Port 1

Array 1, LUN 0

Setting:	Value:
Select arrays to use	Array 1
Size (GB)	363
Block size	512
Availability	Controller 1 Port 0

Array 1, LUN 1

Setting:	Value:
Select arrays to use	Array 1
Size (GB)	363
Block size	512
Availability	Controller 1 Port 1

10. Click Close.

Rescanning New LUNs from the Host Operating System

Newly-created LUNs must be rescanned by the host operating system to associate the proper disk devices with each LUN.

To rescan LUNs:

1. Reboot the system.
2. Verify the new LUNs were detected:
 - On Linux, examine the content of the file `/proc/scsi/scsi`.
 - On IRIX, type the following command and examine the output:

```
hinv
```

XR-Series LUN Mapping for Red Hat 3 Linux

The procedure in this section is mandatory for all XR-series storage connected to systems running Effects or Editing software under Linux Red Hat® Enterprise Linux® WS 3, Update 5

or earlier. If you are running Red Hat Enterprise Linux WS 4, you do not need to perform this procedure.

You must perform this procedure when you connect the workstation to XR-series storage for the first time, when you replace a fibre channel adapter on a workstation that was already connected to XR-series storage, and when you reorganize individual workstation-to-storage connections. You perform the procedure prior to mounting and creating the Stone filesystem on the workstation.

The procedure associates logical drive numbers with LUNs, and maps these to each of the fibre channel ports on the Linux workstation that you are connecting to your storage configuration. This mapping ensures the operating system detects all LUNs in the storage configuration, and consequently ensures all storage in the configuration is available for use.

NOTE: This procedure assumes you have already created the arrays and logical drives for the storage configuration. If necessary, refer to [“XR-Series LUN Creation Using the XR Configuration Utility”](#) on page 62.

To map logical drive numbers to fibre channel ports:

1. Cable the Linux workstation to storage as illustrated in this guide.
2. Power on the storage and workstation, in the correct sequence. See [“Powering Up and Down”](#) on page 17.
3. Connect to the Stone Storage Manager on the XR RAID enclosure. If you have a four-loop configuration, connect to one of the two XR RAID enclosures (you will perform the procedure once for each XR RAID enclosure). See [“Accessing the RAID Controllers”](#) on page 59.
4. In the Stone Storage Manager, click SAN Mapping.

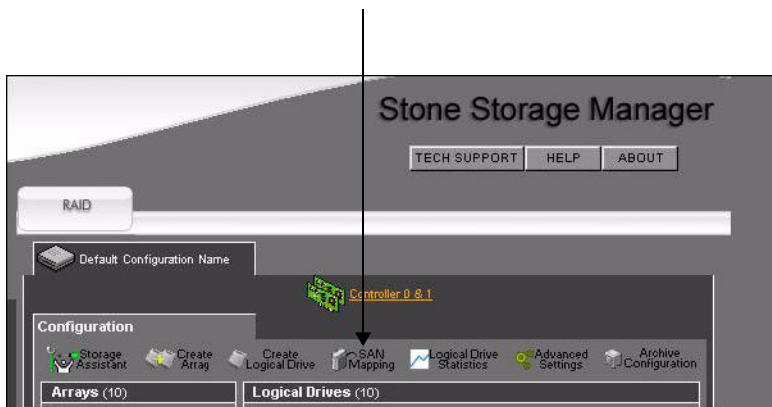

- In the SSM LUN Mapping window that appears, locate the names of the fibre channel adapter ports on the Linux workstation, in the Name area on the left of the window. Only the ports physically connected to this XR RAID enclosure appear. If this is the first time you are mapping logical drive numbers to the fibre channel ports, each port appears as 'Unnamed'.

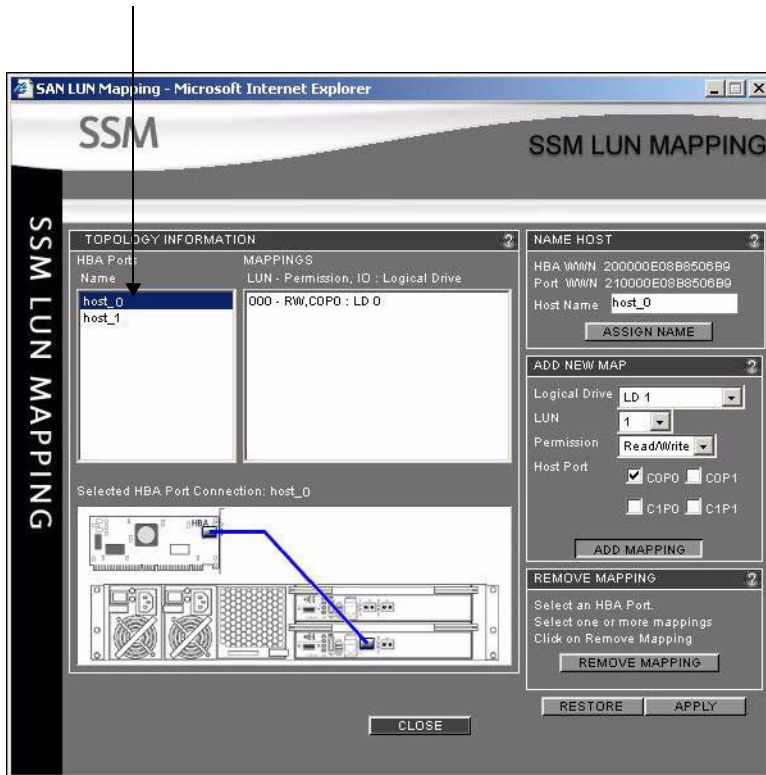

- If necessary, rename the ports 'host_0' and 'host_1'. Ensure that 'host_0' refers to controller 0 (the bottom controller) and host_1 refers to controller 1 (the top controller). Use the graphic of the backplane of the XR RAID enclosure at the bottom of the window to verify this is the case. To rename a port, type the new name in the Host Name field to the right of the Name area, then click ASSIGN NAME.
- Map the first LUN and logical drive to the host_0 port on the Linux workstation as follows:
 - In the Name area, select host_0.
 - In the ADD NEW MAP area, adjust the settings to the following values:

Field:	Value:
Logical Drive	LD 0
LUN	0
Permission	Read/Write
Host Port	C0P0 (The host_0 port connects to port 0 of RAID controller 0 on the XR RAID enclosure.)

- Click ADD MAPPING.

The MAPPINGS area to the right of the Name area updates to reflect the mapping.

NOTE: If you inadvertently create an incorrect mapping you can delete it by selecting the mapping in the MAPPINGS area, and clicking REMOVE MAPPING (at the bottom right of the window).

8. Map the first LUN and logical drive to the host_1 port on the Linux workstation as follows:

- In the Name area, select host_1.
- In the ADD NEW MAP area, adjust the settings to the following values:

Field:	Value:
Logical Drive	LD 1
LUN	0
Permission	Read/Write
Host Port	C1P0 (The host_1 port connects to port 0 of RAID controller 1 on the XR RAID enclosure.)

- Click ADD MAPPING.

The MAPPINGS area to the right of the Name area updates to reflect the mapping.

9. If you have XE RAID expansion enclosures connected to the XR RAID enclosure, repeat steps 7 and 8 to map the remaining LUN and logical drive pairs for those enclosures. The following table lists the correct mappings for one XR RAID enclosure and up to two XE (EBOD) expansion enclosures:

Host	LUN	LD	Permission	Host Port
host_0	0	0	Read/Write	C0P0
	1	2	Read/Write	C0P0
	2	4	Read/Write	C0P0
host_1	0	1	Read/Write	C1P0
	1	3	Read/Write	C1P0
	2	5	Read/Write	C1P0

When you have completed the mapping, all even logical drive numbers should be associated with host_0, and all odd logical drive numbers should be associated with host_1.

The following two screenshots show an example mapping for one XR RAID enclosure and two XE RAID expansion enclosures.

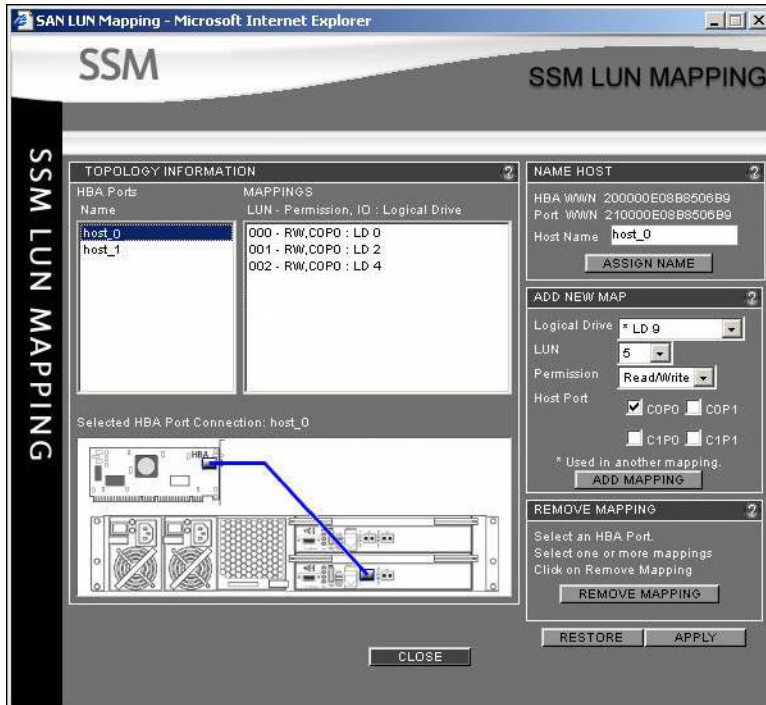

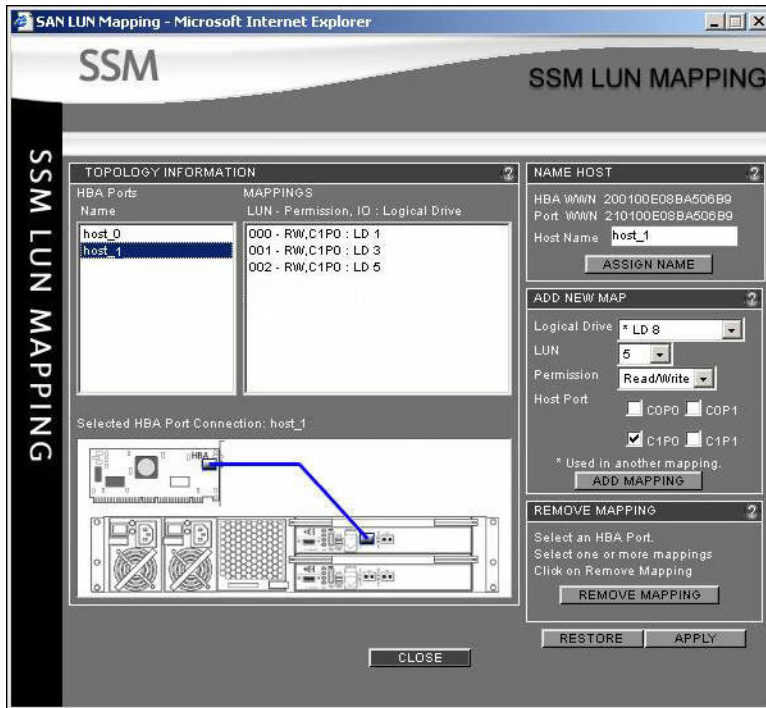

10. If you have a four-loop configuration, repeat steps 3 through 9 for the second XR RAID enclosure.
11. Reboot the Linux workstation.
The Linux workstation now detects all LUNs in the storage configuration.

XR-Series LUN Mapping for Lustre Under Red Hat 3 Linux

The procedure in this section is mandatory for all 4-loop, single XR-RAID enclosure storage configurations connected to Linux workstations running Lustre under Red Hat® Enterprise Linux® WS 3, Update 5 or earlier.

You perform the procedure prior to mounting and creating the Stone filesystem on the workstation. The procedure associates logical drive numbers with LUNs, and maps these to each of the fibre channel ports on the Linux workstation that you are connecting to your storage configuration. This mapping ensures the operating system detects all LUNs in the storage configuration, and consequently ensures all storage in the configuration is available for use.

NOTE: This procedure assumes you have already created the arrays and logical drives for the storage configuration. If necessary, refer to [“XR-Series LUN Creation Using the XR Configuration Utility”](#) on page 62.

To map logical drive numbers to fibre channel ports:

1. Cable the Linux workstation to storage as illustrated in this guide.
2. Power on the storage and workstation, in the correct sequence. See [“Powering Up and Down”](#) on page 17.
3. Connect to the Stone Storage Manager on the XR RAID enclosure. See [“Accessing the RAID Controllers”](#) on page 59.
4. In the Stone Storage Manager, click SAN Mapping.

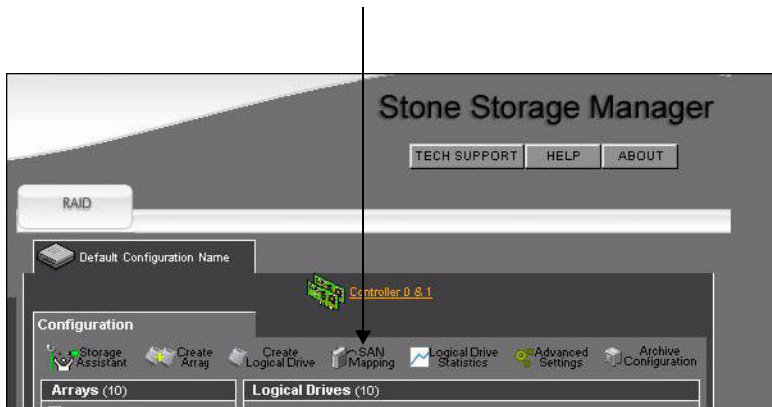

5. In the SSM LUN Mapping window that appears, locate the names of the fibre channel adapter ports on the Linux workstation, in the Name area on the left of the window. Only the ports physically connected to this XR RAID enclosure appear. If this is the first time you

are mapping logical drive numbers to the fibre channel ports, each port appears as 'Unnamed'.

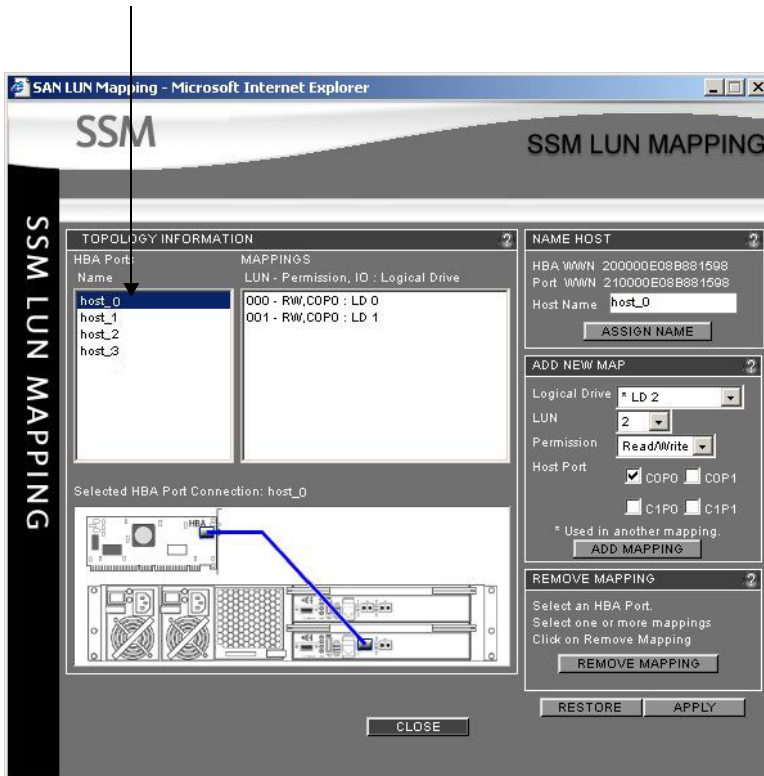

- If necessary, rename the fibre channel ports 'host_0' through 'host_3'.

NOTE: To rename a port, type the new name in the Host Name field to the right of the Name area, then click ASSIGN NAME.

Ensure that the ports are mapped to the correct controllers, as listed below. Use the graphic of the XR RAID enclosure at the bottom of the window to verify the mappings.

Port Name	Physical Port on QLA2344 Board	XR RAID Controller and Port
host_0	1	Controller 0, Port 0 (bottom left)
host_1	2	Controller 0, Port 1 (bottom right)
host_2	3	Controller 1, Port 0 (top left)
host_3	4	Controller 1, Port 1 (top right)

7. Map LUNs and logical drives to each of the fibre channel ports as follows:

- In the Name area, select the fibre channel port.
- In the ADD NEW MAP area, adjust the settings to the correct values for the first LUN on that port, as listed in the tables below.
- Click ADD MAPPING.

The MAPPINGS area to the right of the Name area updates to reflect the mapping.

- In the ADD NEW MAP area, adjust the settings to the correct values for the second LUN on that port, as listed in the tables below.
- Click ADD MAPPING.

The MAPPINGS area to the right of the Name area updates to reflect the mapping.

- Repeat the above sequence of steps for each fibre channel port.

NOTE: If you inadvertently create an incorrect mapping you can delete it by selecting the mapping in the MAPPINGS area, and clicking REMOVE MAPPING (at the bottom right of the window).

host_0, first LUN

Field:	Value:
Logical Drive	LD 0
LUN	0
Permission	Read/Write
Host Port	COP0 (The host_0 port connects to port 0 of RAID controller 0 on the XR RAID enclosure.)

host_0, second LUN

Field:	Value:
Logical Drive	LD 1
LUN	1
Permission	Read/Write
Host Port	COP0 (The host_0 port connects to port 0 of RAID controller 0 on the XR RAID enclosure.)

host_1, first LUN

Field:	Value:
Logical Drive	LD 4
LUN	0

Field:	Value:
Permission	Read/Write
Host Port	COP1 (The host_1 port connects to port 1 of RAID controller 0 on the XR RAID enclosure.)

host_1, second LUN

Field:	Value:
Logical Drive	LD 5
LUN	1
Permission	Read/Write
Host Port	COP1 (The host_1 port connects to port 1 of RAID controller 0 on the XR RAID enclosure.)

host_2, first LUN

Field:	Value:
Logical Drive	LD 2
LUN	0
Permission	Read/Write
Host Port	C1P0 (The host_2 port connects to port 0 of RAID controller 1 on the XR RAID enclosure.)

host_2, second LUN

Field:	Value:
Logical Drive	LD 3
LUN	1
Permission	Read/Write
Host Port	C1P0 (The host_2 port connects to port 0 of RAID controller 1 on the XR RAID enclosure.)

host_3, first LUN

Field:	Value:
Logical Drive	LD 6
LUN	0

Field:	Value:
Permission	Read/Write
Host Port	C1P1 (The host_3 port connects to port 1 of RAID controller 1 on the XR RAID enclosure.)

host_3, second LUN

Field:	Value:
Logical Drive	LD 7
LUN	1
Permission	Read/Write
Host Port	C1P1 (The host_3 port connects to port 1 of RAID controller 1 on the XR RAID enclosure.)

8. Map LUNs and logical drives to each of the fibre channel ports as follows:

- In the Name area, select the fibre channel port.
- In the ADD NEW MAP area, adjust the settings to the correct values for the first LUN on that port, as listed in the tables below.
- Click ADD MAPPING.

The MAPPINGS area to the right of the Name area updates to reflect the mapping.

- If your configuration includes an XE (EBOD) expansion enclosure, in the ADD NEW MAP area, adjust the settings to the correct values for the second LUN on that port, as listed in the tables below. Then Click ADD MAPPING to add the mapping for the LUN on the EBOD enclosure.
- Repeat the above sequence of steps for each fibre channel port.

NOTE: If you inadvertently create an incorrect mapping you can delete it by selecting the mapping in the MAPPINGS area, and clicking REMOVE MAPPING (at the bottom right of the window).

host_0, first LUN

Field:	Value:
Logical Drive	LD 0
LUN	0
Permission	Read/Write
Host Port	C0P0 (The host_0 port connects to port 0 of RAID controller 0 on the XR RAID enclosure.)

host_0, second LUN (only for configurations with an XE (EBOD) expansion enclosure)

Field:	Value:
Logical Drive	LD 1
LUN	1
Permission	Read/Write
Host Port	C0P0 (The host_0 port connects to port 0 of RAID controller 0 on the XR RAID enclosure.)

host_1, first LUN

Field:	Value:
Logical Drive	LD 1 (for configurations without an XE (EBOD) expansion enclosure) LD 4 (for configurations with an XE (EBOD) expansion enclosure)
LUN	0
Permission	Read/Write
Host Port	C0P1 (The host_1 port connects to port 1 of RAID controller 0 on the XR RAID enclosure.)

host_1, second LUN (only for configurations with an XE (EBOD) expansion enclosure)

Field:	Value:
Logical Drive	LD 5
LUN	1
Permission	Read/Write
Host Port	C0P1 (The host_1 port connects to port 1 of RAID controller 0 on the XR RAID enclosure.)

host_2, first LUN

Field:	Value:
Logical Drive	LD 2
LUN	0
Permission	Read/Write
Host Port	C1P0 (The host_2 port connects to port 0 of RAID controller 1 on the XR RAID enclosure.)

host_2, second LUN (only for configurations with an XE (EBOD) expansion enclosure)

Field:	Value:
Logical Drive	LD 3
LUN	1
Permission	Read/Write
Host Port	C1P0 (The host_2 port connects to port 0 of RAID controller 1 on the XR RAID enclosure.)

host_3, first LUN

Field:	Value:
Logical Drive	LD 3 (for configurations without an XE (EBOD) expansion enclosure) LD 6 (for configurations with an XE (EBOD) expansion enclosure)
LUN	0
Permission	Read/Write
Host Port	C1P1 (The host_3 port connects to port 1 of RAID controller 1 on the XR RAID enclosure.)

host_3, second LUN (only for configurations with an XE (EBOD) expansion enclosure)

Field:	Value:
Logical Drive	LD 7
LUN	1
Permission	Read/Write
Host Port	C1P1 (The host_3 port connects to port 1 of RAID controller 1 on the XR RAID enclosure.)

9. Verify the mappings are correct. The first of the following two tables lists the correct mappings for a single XR RAID configuration. The second lists the correct mappings for one XR RAID enclosure and one XE (EBOD) expansion enclosure.

Host	LUN	LD	Permission	Host Port
host_0	0	0	Read/Write	C0P0
host_1	0	1	Read/Write	C0P1
host_2	0	2	Read/Write	C1P0
host_3	0	3	Read/Write	C1P1

Host	LUN	LD	Permission	Host Port
host_0	0	0	Read/Write	C0P0
	1	1	Read/Write	C0P0
host_1	0	4	Read/Write	C0P1
	1	5	Read/Write	C0P1
host_2	0	2	Read/Write	C1P0
	1	3	Read/Write	C1P0
host_3	0	6	Read/Write	C1P1
	1	7	Read/Write	C1P1

The following screenshots show an example mapping for one XR RAID enclosure and one XE RAID expansion enclosure.

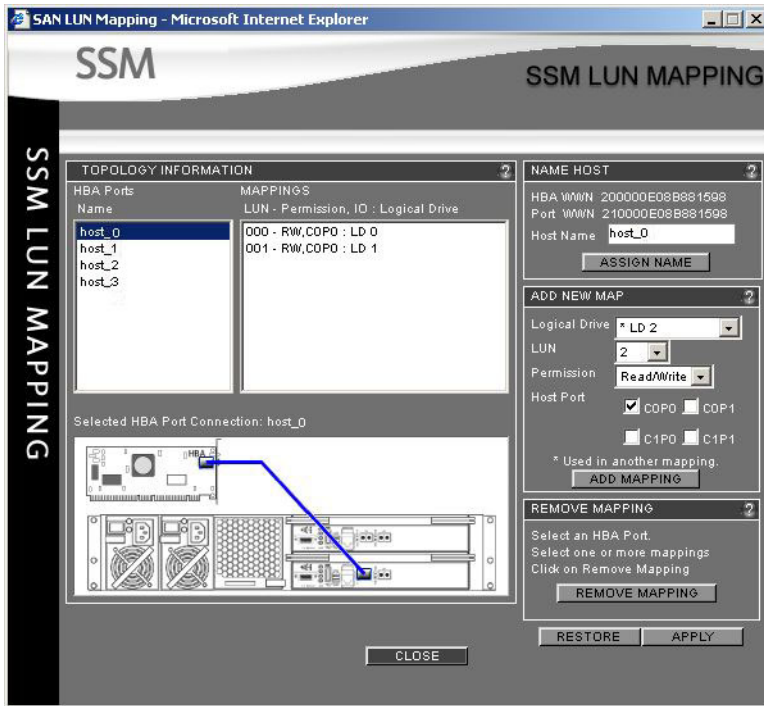

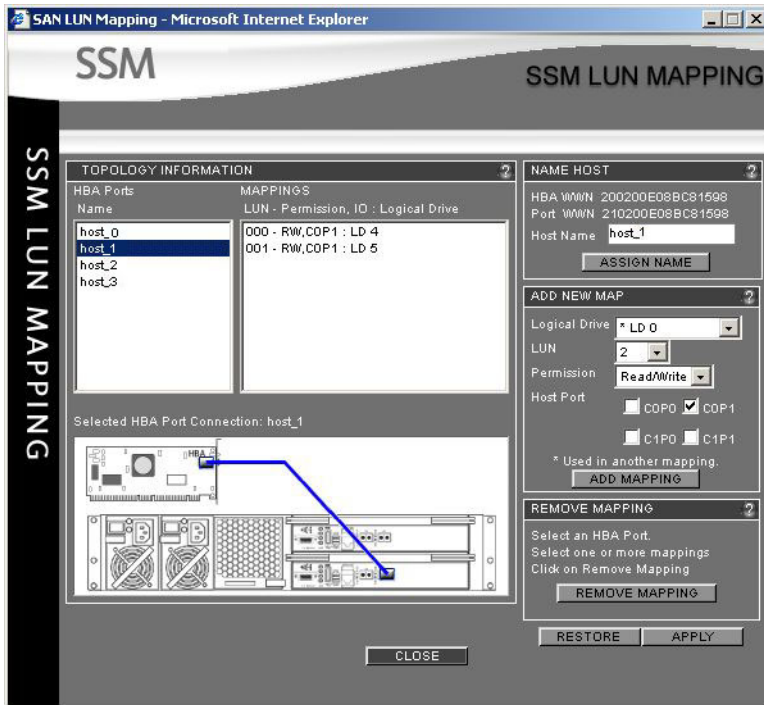

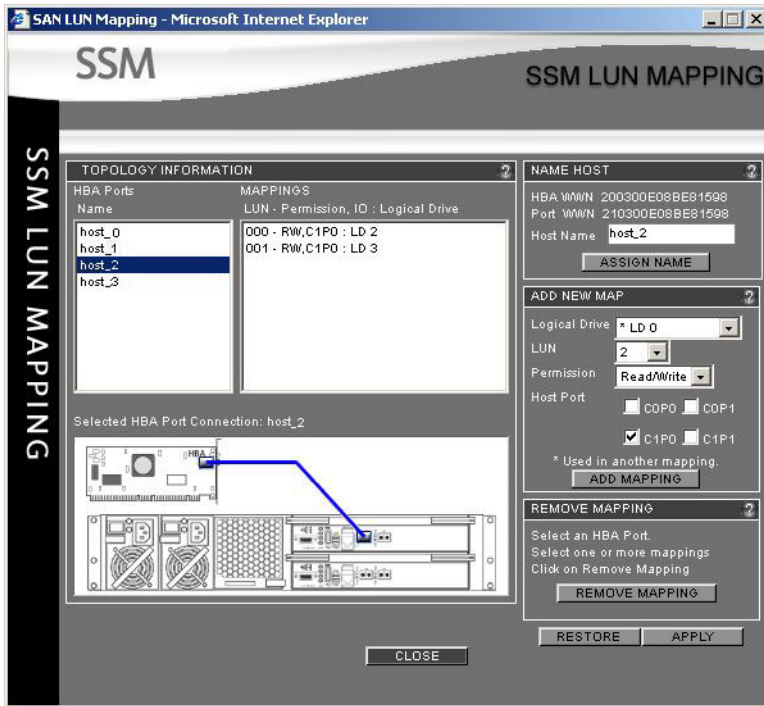

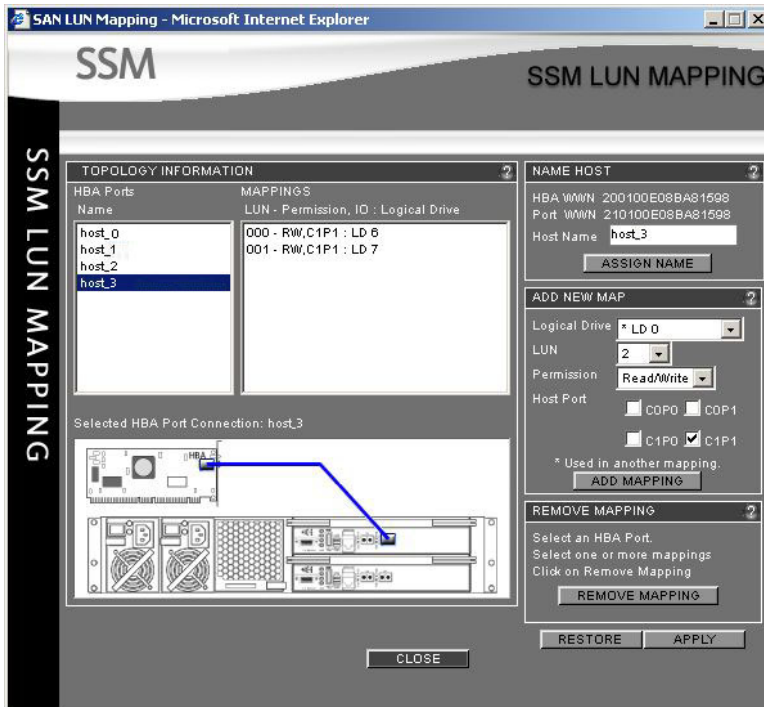

10. Reboot the Linux workstation.

The Linux workstation now detects all LUNs in the storage configuration.

IR-Series LUN Creation and Management Using DSM

To create or manage the LUNs on your IR-series, access the RAID controllers using the Discreet Storage Manager (DSM) utility provided with your storage configuration. Refer to the *Discreet Storage Manager Installation and User's Guide, 3rd Edition* for detailed descriptions and procedures.

Accessing the RAID Controller

Before you can access the IR-series RAID controller, you must enable the DSM. If you have a Linux workstation running version 7.0 of Editing products, version 9.5 of Autodesk Flame® or Autodesk Flint®, products, version 6.5 of Autodesk Inferno®, or any later version of these products, you can enable the DSM server by typing the following:

```
chkconfig httpd on
```

```
/etc/init.d/httpd restart
```

If you have an earlier version of your product, or if you have an IRIX workstation, please refer to *Discreet Storage Manager Installation and User's Guide 3rd Edition* for instructions on how to set up and enable the DSM server.

Accessing the DSM

Access the DSM by pointing a web browser to the IP or hostname of the workstation to which the RAID storage is attached. This Web browser can be launched from the workstation itself or from any Linux or IRIX workstation on the same local network. Point the browser at the address *http://<hostname or IP>/dsm/dsm.htm*

NOTE: The root password is required.

Creating LUNs

To configure RAID LUNs on IR-series storage, you upload a preset LUN configuration file to the RAID controller through DSM.

Preset LUN configuration files differ depending on the size of drives in your enclosures, the number of expansion enclosures and the type of application you are using. Contact Customer Support to obtain the certified LUN configuration file for your configuration.

Download this LUN configuration file to your workstation, and then use the following procedure to upload that file to the RAID controller.

To upload the LUN configuration file to the RAID controller:

1. In the DSM, select “Controller >> Restore Configuration”.
A file browser opens.
2. Browse to your preset LUN configuration file and select it.
The LUN configuration is uploaded and applied.

Initializing a LUN

Newly created LUNs must undergo an initialization which can be performed in the background. During this initialization, storage is available but performance may be slightly degraded for the duration of the initialization.

To initialize a LUN you write to the volume. You can perform an FX or FDISK to force a background initialization on the LUN. Alternatively, you can click on a LUN in the DSM and select Initialize Arrays.

Rescanning New LUNs from the Host Operating System

Newly-created LUNs must be rescanned by the host operating system to associate the proper disk devices with each LUN.

To rescan LUNs:

1. Reboot the system.
2. Verify the new LUNs were detected:
 - On Linux, examine the content of the file */proc/scsi/scsi*.
 - On IRIX, type the following command and examine the output:

hinv

Recommended Inode Ratios for XR-Series



Summary

About This Appendix	93
About Inodes and Inode Ratios	93
Recommended Inode Ratio Tables	94

About This Appendix

The tables in this appendix provide recommended inode ratios for single resolution workflows on XR-series storage. If you are using a mixed resolution workflow with XR-series storage, the rule of thumb is to use the inode value for the lowest resolution. For example, if you use NTSC and HD resolutions in your workflows, use the inode ratio value for NTSC.

NOTE: The maximum size of a Stone filesystem is 8 terabytes on IRIX systems. On Linux systems the maximum Stone filesystem size is 4 terabytes for SD resolution and 8 terabytes for HD resolution.

NOTE: This appendix applies to the Stone filesystem only. It does not apply to Lustre as Lustre uses the NTFS (Windows) or XFS (Linux) filesystem.

About Inodes and Inode Ratios

An inode is a data structure that holds information about a single frame stored in a Stone partition. Each frame or clip in your clip library is described by a single inode in the Stone partition.

When you set up your Stone filesystem, you must enter an inode ratio that is used to calculate the total number of inodes available per Stone partition. For example, you might have one inode for every 1024 KB of filesystem space. If you have a 4TB filesystem, this would provide you with 4 million inodes, and therefore, the possibility of storing 4 million frames.

The default inode ratio is 1024. The minimum value is 512 and the maximum value is 6656. The inode ratio is rounded up to the nearest 512 KB multiple (i.e. 513 rounds up to 1024). Generally, the number of inodes is related to the frame size of your most common production format and the size of your Stone partition.

For help entering the inode ratio parameter during storage configuration, refer to the chapter “Creating the Stone Filesystem” in the *Stone and Wire Filesystem and Networking Guide*. In particular, consult the sections “Setting Partition Configuration Parameters” and “sw_config Reference”.

Recommended Inode Ratio Tables

The tables in this section are valid as of Stone and Wire 2.6.

NTSC Workflows

The values in this table are for NTSC 10-bit workflows with a frame size of 1399680 bytes at 30 fps.

	Single XR Enclosure	+ 1 XE Expansion Enclosure	+ 2 XE Expansion Enclosures	+ 3 XE Expansion Enclosures	+ 4 XE Expansion Enclosures
Usable space (GB)	1367.4	2734.8	4102.2	Not supported	Not supported
Recommended inode ratio	1024	1024	1024	Not supported	Not supported
Hours of footage (hh:mm)	9:42	19:25	29:08	Not supported	Not supported

HD Workflows

The values in this table are for 1080i 10-bit HD workflows with a frame size of 8294400 bytes at 30 fps.

	Single XR Enclosure	+ 1 XE Expansion Enclosure	+ 2 XE Expansion Enclosures	+ 3 XE Expansion Enclosures	+ 4 XE Expansion Enclosures
Usable space (GB)	1367.4	2734.8	4102.2	5469.6	6837.0
Recommended inode ratio	2560	3072	3072	3072	3072
Hours of footage (hh:mm)	1:38	3:16	4:55	6:33	8:12

2K Film Workflows

The values in this table are for 2K 10-bit workflows with a frame size of 12746752 bytes at 24 fps.

	Single XR Enclosure	+ 1 XE Expansion Enclosure	+ 2 XE Expansion Enclosures	+ 3 XE Expansion Enclosures	+ 4 XE Expansion Enclosures
Usable space (GB)	1367.4	2734.8	4102.2	5469.6	6837.0
Recommended inode ratio	4096	4096	4096	4608	4608
Hours of footage (hh:mm)	1:19	2:40	4:00	5:19	6:40

4K Film Workflows

The values in this table are for 4K 10-bit workflows with a frame size of 50899872 bytes at 24 fps.

	2 XR Enclosures	+ 2 XE Expansion Enclosure	+ 4 XE Expansion Enclosures	+ 6 XE Expansion Enclosures	+ 8 XE Expansion Enclosures
Usable space (GB)	2734.8	5469.6	8204.4	10939.2	13674.0
Recommended inode ratio	6144	6144	6144	6144	6144
Hours of footage (hh:mm)	0:40	1:20	2:00	2:40	3:20

A Recommended Inode Ratios for XR-Series

index

Numerics

2-loop and 4-loop, defined 43

A

air conditioning, requirements 13

C

capacity, usable 12

conventions, in user's guide 2

D

defined 43

documentation

 revision history 3

documentation, related 3

E

EBOD enclosures 11

electrostatic discharge, avoiding 16

environmental conditions, ideal 16

F

fibre channel adapters

 cabling 20

 terminating 4-port 21

H

handling storage 15

hardware RAID 10

I

inode and inode ratios, defined 93

inode ratios, recommended 94

internal storage, limitations 53

IR-Series

 configurations 47

 defined 10

J

JBOD enclosures 11

L

loop, defined 43

P

power, requirements 13

powering on or off, sequence for 17

R

RAID

 enclosures 11

 strategy 10

RPM speeds, supported 13

S

shutdown sequence 17

software RAID 10

static electricity discharge, avoiding 16

Stone Direct, defined 9

storage assembly 43

storage capacity, usable 12

storage, handling 15

T

terminology 2

U

user's guide
conventions 2

W

workflow, storage configuration 5

X

XR-Series
configurations 44
defined 10