

AutoCAD Electrical 2011

# User's Guide

**Autodesk®**

January 2008

© 2010 Autodesk, Inc. All Rights Reserved. Except as otherwise permitted by Autodesk, Inc., this publication, or parts thereof, may not be reproduced in any form, by any method, for any purpose.

Certain materials included in this publication are reprinted with the permission of the copyright holder.

#### **Trademarks**

The following are registered trademarks or trademarks of Autodesk, Inc., and/or its subsidiaries and/or affiliates in the USA and other countries: 3DEC (design/logo), 3December, 3December.com, 3ds Max, Algor, Alias, Alias (swirl design/logo), AliasStudio, AliasWavefront (design/logo), ATC, AUGI, AutoCAD, AutoCAD Learning Assistance, AutoCAD LT, AutoCAD Simulator, AutoCAD SQL Extension, AutoCAD SQL Interface, Autodesk, Autodesk Envision, Autodesk Intent, Autodesk Inventor, Autodesk Map, Autodesk MapGuide, Autodesk Streamline, AutoLISP, AutoSnap, AutoSketch, AutoTrack, Backburner, Backdraft, Built with ObjectARX (logo), Burn, Buzzsaw, CAiCE, Civil 3D, Cleaner, Cleaner Central, ClearScale, Colour Warper, Combustion, Communication Specification, Constructware, Content Explorer, Dancing Baby (image), DesignCenter, Design Doctor, Designer's Toolkit, DesignKids, DesignProf, DesignServer, DesignStudio, Design Web Format, Discreet, DWF, DWG, DWG (logo), DWG Extreme, DWG TrueConvert, DWG TrueView, DXF, Ecotect, Exposure, Extending the Design Team, Face Robot, FBX, Fempro, Fire, Flame, Flare, Flint, FMDesktop, Freewheel, GDX Driver, Green Building Studio, Heads-up Design, Heidi, HumanIK, IDEA Server, i-drop, ImageModeler, iMOUT, Incinerator, Inferno, Inventor, Inventor LT, Kaydara, Kaydara (design/logo), Kynapse, Kynogon, LandXplorer, Lustre, MatchMover, Maya, Mechanical Desktop, Moldflow, Moonbox, MotionBuilder, Movimento, MPA, MPA (design/logo), Moldflow Plastics Advisers, MPI, Moldflow Plastics Insight, MPX, MPX (design/logo), Moldflow Plastics Xpert, Mudbox, Multi-Master Editing, Navisworks, ObjectARX, ObjectDBX, Open Reality, Opticore, Opticore Opus, Pipeplus, PolarSnap, PortfolioWall, Powered with Autodesk Technology, Productstream, ProjectPoint, ProMaterials, RasterDWG, RealDWG, Real-time Roto, Recognize, Render Queue, Retimer, Reveal, Revit, Showcase, ShowMotion, SketchBook, Smoke, Softimage, SoftimageXSI (design/logo), Sparks, SteeringWheels, Stitcher, Stone, StudioTools, ToolClip, Topobase, Toxik, TrustedDWG, ViewCube, Visual, Visual LISP, Volo, Vtour, Wire, Wiretap, WiretapCentral, XSI, and XSI (design/logo).

All other brand names, product names or trademarks belong to their respective holders.

#### **Disclaimer**

THIS PUBLICATION AND THE INFORMATION CONTAINED HEREIN IS MADE AVAILABLE BY AUTODESK, INC. "AS IS." AUTODESK, INC. DISCLAIMS ALL WARRANTIES, EITHER EXPRESS OR IMPLIED, INCLUDING BUT NOT LIMITED TO ANY IMPLIED WARRANTIES OF MERCHANTABILITY OR FITNESS FOR A PARTICULAR PURPOSE REGARDING THESE MATERIALS.

Published by:  
Autodesk, Inc.  
111 McInnis Parkway  
San Rafael, CA 94903, USA

# Contents

<b>Chapter 1</b>	<b>AutoCAD Electrical What's New</b> . . . . .	<b>1</b>
	Overview of AutoCAD Electrical Help . . . . .	1
	Join the Customer Involvement Program . . . . .	6
	What's New in AutoCAD Electrical 2011 . . . . .	7
	What's New in Previous Releases . . . . .	9
	What's New in 2008 Release . . . . .	13
	What's New in 2009 Release . . . . .	19
	What's New in 2010 Release . . . . .	25
	Ribbon Interface . . . . .	29
	Project tab . . . . .	29
	Project Tools panel . . . . .	29
	Other Tools panel . . . . .	30
	Troubleshooting panel . . . . .	33
	Schematic tab . . . . .	34
	Quick Pick panel . . . . .	34
	Insert Components panel . . . . .	35
	Edit Components panel . . . . .	39
	Insert Wires/Wire Numbers panel . . . . .	48
	Edit Wires/Wire Numbers panel . . . . .	52
	Other Tools panel . . . . .	57
	Power Check Tools panel . . . . .	59
	Panel tab . . . . .	60
	Insert Component Footprints panel . . . . .	60
	Terminal Footprints panel . . . . .	62

	Edit Footprints panel . . . . .	63
	Other Tools panel . . . . .	65
	Conduit Tools panel . . . . .	66
	Reports tab . . . . .	67
	Schematic panel . . . . .	67
	Panel panel . . . . .	68
	Miscellaneous panel . . . . .	68
	Import/Export Data tab . . . . .	69
	Import panel . . . . .	69
	Export panel . . . . .	70
	Conversion Tools tab . . . . .	71
	Tools panel . . . . .	71
	Schematic panel . . . . .	74
	Panel panel . . . . .	76
	Attributes panel . . . . .	76
	Symbol Builder tab . . . . .	79
	Edit panel . . . . .	79
	Help panel . . . . .	80
	Toolbars to Ribbons . . . . .	80
	Main Electrical toolbar . . . . .	80
	Main Electrical 2 toolbar . . . . .	94
	Panel Layout toolbar . . . . .	104
	Conversion toolbar . . . . .	108
	Conduit Marker toolbar . . . . .	115
	Power Check toolbar . . . . .	116
	Extra Libraries toolbar . . . . .	117
	The Ribbon . . . . .	117
	Overview of the Ribbon . . . . .	117
	Display and Organize the Ribbon . . . . .	118
	Customize the Ribbon . . . . .	121
<b>Chapter 2</b>	<b>Migration . . . . .</b>	<b>123</b>
	Migration Utility . . . . .	123
<b>Chapter 3</b>	<b>Project Management . . . . .</b>	<b>137</b>
	Overview of projects . . . . .	137
	Use recently opened projects . . . . .	138
	Create a project . . . . .	138
	Add a new drawing to the current project . . . . .	139
	Add existing drawings to the current project . . . . .	139
	Group drawings within a project . . . . .	142
	Change the order of drawings in the project . . . . .	142
	Remove a drawing from the active project . . . . .	143
	Assign a description to each drawing . . . . .	143
	Preview a drawing . . . . .	144

	About collaborative design . . . . .	156
	Create a drawing . . . . .	167
	Change drawing display options . . . . .	171
	Overview of project-related files . . . . .	174
	Overview of the project file format . . . . .	182
	Archive a project . . . . .	187
	Delete a project . . . . .	188
	Work with Multiple Clients . . . . .	189
	Overview of setup for multiple clients . . . . .	189
	Drawing List Report . . . . .	192
	IEC tag mode update . . . . .	192
	Task list . . . . .	193
<b>Chapter 4</b>	<b>Drawing and Project Properties . . . . .</b>	<b>199</b>
	Overview of project and drawing properties . . . . .	199
	Use replaceable parameters . . . . .	236
	Save settings to the project file . . . . .	239
	Settings List Utility . . . . .	241
	Create a template drawing . . . . .	244
	Updating the WD_M Block . . . . .	248
	Overview of the WD_M block . . . . .	248
	Using Layers . . . . .	256
	Manage layers . . . . .	256
	Use wire layers . . . . .	264
	Change wire types . . . . .	273
<b>Chapter 5</b>	<b>Symbol Libraries . . . . .</b>	<b>281</b>
	Determine symbol block names . . . . .	281
	Library Symbol Naming Conventions . . . . .	282
	Overview of symbol naming conventions . . . . .	282
	Split a tag name into two pieces . . . . .	298
	Use multiple symbol libraries . . . . .	299
	Overview of one-line symbols . . . . .	301
	Overview of Hydraulic and P&ID symbols . . . . .	304
	Attribute Requirements . . . . .	306
	Schematic attributes . . . . .	306
	Overview of schematic attributes . . . . .	306
	Overview of parent and stand-alone component attributes (TAG1) . . . . .	320
	Overview of child component attributes (TAG2) . . . . .	321
	Panel attributes . . . . .	321
	Overview of panel attributes . . . . .	321
	Attributes for other symbol categories . . . . .	325
	Overview of attributes for other symbol categories . . . . .	325
	Copy attributes . . . . .	329

Managing Library Symbols . . . . .	329
Substitute symbols in the library . . . . .	329
Change appearance of existing library symbols . . . . .	330
Predefine symbol annotation . . . . .	331
Swap blocks . . . . .	332
Create a library symbol . . . . .	338
Symbol Builder . . . . .	339
Symbol Builder . . . . .	339

**Symbol Preview Guide . . . . . 361**

<b>Chapter 6 JIC Symbols . . . . .</b>	<b>363</b>
Push Buttons . . . . .	363
Selector Switches . . . . .	366
Selector Switches . . . . .	366
Illuminated Selector Switches . . . . .	370
Fuses, Circuit Breakers, Transformers . . . . .	374
Fuses and Transformers . . . . .	374
Circuit Breakers and Disconnects . . . . .	376
Relays and Contacts . . . . .	378
Relays and Contacts . . . . .	378
Latch Relay Coils . . . . .	379
Timers . . . . .	380
Time Delay Relays . . . . .	380
OFF-Delay Timers . . . . .	382
Motor Control . . . . .	384
Pilot Lights . . . . .	387
Pilot Lights . . . . .	387
Master Test Pilot Lights . . . . .	390
Neon Pilot Lights . . . . .	391
PLC I/O . . . . .	392
Terminals and Connectors . . . . .	394
Terminals . . . . .	394
In-Line Wire Labels . . . . .	397
Power Distribution Blocks . . . . .	398
Connectors - No Wirenumber Changes . . . . .	399
Connectors - Wirenumber Changes . . . . .	403
Limit Switches . . . . .	407
Pressure and Temperature Switches . . . . .	408
Flow and Level Switches . . . . .	410
Miscellaneous Switches . . . . .	411
Miscellaneous Switches . . . . .	411
Single Pole Double Throw Switches . . . . .	415
Solenoids . . . . .	418
Instrumentation . . . . .	419

	Miscellaneous . . . . .	421
	Miscellaneous . . . . .	421
	Electronics . . . . .	423
	Cable Markers . . . . .	426
	Power Receptacles . . . . .	427
	Generic Device Boxes . . . . .	427
	Stand-alone Cross-reference Symbols . . . . .	428
	Wire Arrows - Reference Only . . . . .	430
	One-Line Components . . . . .	431
	Connector . . . . .	431
	Motor Control . . . . .	431
	Transformer . . . . .	433
	Terminal . . . . .	434
	Cable Marker . . . . .	434
	Bus-tap . . . . .	435
	Miscellaneous . . . . .	435
<b>Chapter 7</b>	<b>IEC Symbols . . . . .</b>	<b>437</b>
	Push Buttons . . . . .	437
	Push Buttons . . . . .	437
	Illuminated Push Buttons . . . . .	441
	Selector Switches . . . . .	442
	Selector Switches . . . . .	442
	3 Position Selector Switches . . . . .	445
	4 Position Selector Switches . . . . .	450
	Breakers, Disconnects . . . . .	452
	1 Pole Circuit Breakers . . . . .	452
	2nd+ Pole Circuit Breakers . . . . .	454
	Power Switches . . . . .	458
	Fusible Disconnects . . . . .	459
	Disconnect 1 Pole . . . . .	461
	Fuses, Transformers, Reactors . . . . .	462
	Reactors . . . . .	462
	Fuses . . . . .	463
	Fuse Switches . . . . .	465
	Transformers . . . . .	465
	Current Transformers . . . . .	467
	3 Phase Transformers . . . . .	469
	Relays, Contacts . . . . .	473
	Relays and Contacts . . . . .	473
	Relays with Suppression . . . . .	476
	Current Protection Relays . . . . .	477
	Voltage Protection Relays . . . . .	479
	Counter Relays . . . . .	480
	Miscellaneous Relays . . . . .	481
	Time Delay Relays . . . . .	482

Motor Control . . . . .	485
Motor Control . . . . .	485
1 Phase Motors . . . . .	486
3 Phase Motors . . . . .	487
DC Motors . . . . .	489
Generators . . . . .	490
Motor Starters . . . . .	491
Pilot Lights . . . . .	492
Pilot Lights . . . . .	492
Standard Lights . . . . .	493
Transformer Lights . . . . .	494
Push to Test Lights . . . . .	496
LEDs . . . . .	497
Beacons - Flashing . . . . .	500
Beacons - Rotating . . . . .	502
PLC I/O . . . . .	503
Terminals, Connectors . . . . .	505
Terminals . . . . .	505
In-Line Wire Labels . . . . .	508
Power Distribution Blocks . . . . .	509
Connectors - No Wirenumber Changes . . . . .	509
Connectors - Wirenumber Changes . . . . .	513
Limit Switches . . . . .	516
Pressure and Temperature Switches . . . . .	520
Proximity Switches . . . . .	522
Inductive Switches . . . . .	522
Capacitive Switches . . . . .	524
Magnetic Switches . . . . .	526
Photoelectric Emitter Switches . . . . .	528
Photoelectric Receiver Switches . . . . .	530
Photoelectric Emitter/Receiver Switches . . . . .	533
Ultrasonic Switches . . . . .	535
Touch Switches . . . . .	537
Miscellaneous Switches . . . . .	539
Solenoids . . . . .	545
Instrumentation and Sensors . . . . .	547
Qualifying Symbols . . . . .	551
Operating Devices . . . . .	551
Linear Direction of Force or Motion . . . . .	557
Rotative Direction of Force or Motion . . . . .	557
Propagation Flow or Signal . . . . .	558
Energy Flow . . . . .	559
Effect . . . . .	560
Radiation . . . . .	560
Fault . . . . .	561
Winding . . . . .	562



	Mechanical Controls . . . . .	565
	Mechanical Controls, Latching Device . . . . .	566
	Mechanical Controls, Coupling . . . . .	567
Miscellaneous . . . . .	Miscellaneous . . . . .	568
	Electronics . . . . .	570
	Cable Markers . . . . .	575
	Power Receptacles . . . . .	576
	Generic Device Boxes . . . . .	576
	Stand-alone Cross-reference Symbols . . . . .	577
	Wire Arrows - Reference Only . . . . .	579
	Splice Symbols . . . . .	580
	Annunciations . . . . .	580
One-Line Components . . . . .	One-Line Components . . . . .	581
	Connector . . . . .	581
	Motor Control . . . . .	581
	Transformer . . . . .	583
	Terminal . . . . .	584
	Cable Marker . . . . .	584
	Bus-tap . . . . .	585
	Miscellaneous . . . . .	585
<b>Chapter 8</b>	<b>PLC . . . . .</b>	<b>587</b>
	Generate PLC layout modules . . . . .	587
	Parametric PLC symbols vs. Full Units . . . . .	588
	Insert PLC modules . . . . .	591
	Overview of the PLC database file . . . . .	596
	Single, Stand-alone I/O Points . . . . .	620
	Modify single, stand-alone PLC layout symbols . . . . .	620
	Work with PLC styles . . . . .	624
	Modify a PLC appearance style . . . . .	624
	Create a PLC style . . . . .	624
	Add a new PLC style . . . . .	625
	Create PLC I/O Drawings from Spreadsheets . . . . .	626
	Overview of the PLC spreadsheet/database format . . . . .	626
	Create PLC spreadsheets using RSLogix . . . . .	639
	Create PLC drawings from Unity Pro . . . . .	642
	Create XML files for export to Unity Pro . . . . .	651
<b>Chapter 9</b>	<b>Circuits . . . . .</b>	<b>653</b>
	Circuit Builder . . . . .	653
	Circuit Builder overview . . . . .	653
	Spreadsheet . . . . .	655
	Drawing templates . . . . .	659
	Electrical standards database file . . . . .	663

	Electrical standards database editor . . . . .	681
	Use Circuit Builder . . . . .	687
	Recalculate wire size . . . . .	720
	Reference an existing circuit . . . . .	721
	Use circuitry . . . . .	724
	Add existing circuits to the icon menu . . . . .	727
<b>Chapter 10</b>	<b>Component Tools . . . . .</b>	<b>737</b>
	Insert schematic components . . . . .	737
	Insert or edit child components . . . . .	764
	Insert a copy of a component . . . . .	773
	Insert from catalog lists . . . . .	776
	The schematic lookup file . . . . .	780
	Insert from equipment lists . . . . .	785
	Insert from panel lists . . . . .	789
	Manipulate Components . . . . .	796
	Manipulate components . . . . .	796
	Annotate ratings attributes . . . . .	806
	Swap contact states . . . . .	808
	Component Cross-References . . . . .	809
	Cross-Referencing . . . . .	809
	Check coil/contact count . . . . .	813
	Overview of cross-reference settings . . . . .	815
	Overview of graphical cross-reference formats . . . . .	820
	Overview of table cross-reference formats . . . . .	824
	Update cross-reference tables . . . . .	832
	Use stand-alone cross-reference symbols . . . . .	837
	Insert dashed link lines . . . . .	845
	Follow signals . . . . .	848
	Show signal paths . . . . .	849
	Overview of DIN Rails . . . . .	849
	Overview of user data records . . . . .	853
	Wire Jumpers . . . . .	855
	Define wire jumpers . . . . .	855
<b>Chapter 11</b>	<b>Component Attribute Tools . . . . .</b>	<b>859</b>
	Edit attribute values . . . . .	859
	Force attributes to layers . . . . .	861
	Manipulate component text . . . . .	863
	Manipulate terminal text . . . . .	866
	Move description values . . . . .	867
	Move attributes . . . . .	868
	Hide attributes . . . . .	868
	Show attributes . . . . .	869
	Rotate attributes . . . . .	869

Change attribute justification . . . . .	870
Change attribute text style . . . . .	871
Change attribute text size . . . . .	871
Rename an attribute . . . . .	874
Add attributes to blocks . . . . .	875
Set tags to fixed . . . . .	876
Retag components . . . . .	878
Change to multi-line text . . . . .	879
Add location codes . . . . .	880
Update child codes . . . . .	881
Location Mark Symbols . . . . .	883
Substitute location mark symbols for text location codes . . . . .	883
Location box . . . . .	887
Modify library symbols . . . . .	892
<b>Chapter 12 Wire/Wire Number Tools . . . . .</b>	<b>895</b>
Overview of wires . . . . .	895
Use wire layers . . . . .	895
Change wire types . . . . .	907
Insert wires . . . . .	912
Insert multiple wires . . . . .	916
Interconnect components . . . . .	918
Trim wires . . . . .	919
Stretch wires . . . . .	920
Bend wires at right angles . . . . .	921
Overview of wire color/gauge labels . . . . .	922
Insert in-line wire markers . . . . .	924
Cable Markers . . . . .	929
Insert cable markers into wires . . . . .	929
Multiple cable markers . . . . .	947
Edit the cable conductor database . . . . .	953
Edit the list of generic colors . . . . .	954
Insert shield symbols . . . . .	954
Wire Gaps . . . . .	956
Manipulate wire gaps . . . . .	956
Ladder Tools . . . . .	958
Define and insert new ladders . . . . .	958
Modify an existing ladder . . . . .	963
Wire Numbers . . . . .	969
Overview of wire numbers . . . . .	969
Set wire number placement . . . . .	978
Find or replace wire number text . . . . .	986
Encode wire color/gauge information into wire numbers . . . . .	987
Fix Wire Numbering . . . . .	990
Fix wire numbering . . . . .	990
Reposition Wire Numbers . . . . .	996

	Reposition wire numbers . . . . .	996
	Modify Wire Numbers . . . . .	1007
	Modify wire numbers . . . . .	1007
	Erase or Hide Wire Numbers . . . . .	1008
	Erase or hide wire numbers . . . . .	1008
	Signal Arrows . . . . .	1010
	Signal Arrows . . . . .	1010
	Fan In/Out Markers . . . . .	1019
	Fan In/Out Source and Destination Markers . . . . .	1019
	Wire Sequencing . . . . .	1026
	Control from/to report connection sequencing . . . . .	1026
<b>Chapter 13</b>	<b>Terminal Tools . . . . .</b>	<b>1039</b>
	Insert terminals and connectors . . . . .	1039
	Multi-Level Terminals . . . . .	1053
	Overview of terminal relationships . . . . .	1053
	Terminal Properties Lookup . . . . .	1058
	Overview of terminal properties database . . . . .	1058
	Terminal Strip Editor . . . . .	1064
	Use the terminal strip editor . . . . .	1064
	Generate terminal strip tables . . . . .	1113
	Terminal jumpers . . . . .	1121
	Terminal strip utilities . . . . .	1127
	Terminal wire connections . . . . .	1130
	Resequence terminal numbers . . . . .	1132
	Overview of connection sequencing . . . . .	1133
<b>Chapter 14</b>	<b>Point-to-Point Wiring Tools . . . . .</b>	<b>1139</b>
	Working with Connectors . . . . .	1139
	Use point-to-point wiring tools . . . . .	1139
	Bend wires at right angles . . . . .	1161
	Insert multiple bus wiring . . . . .	1162
	Import data from Autodesk Inventor Professional Cable & Harness . . . . .	1163
	Overview of the spreadsheet import file structure . . . . .	1174
	Insert splices . . . . .	1184
<b>Chapter 15</b>	<b>Project-Wide Tools . . . . .</b>	<b>1185</b>
	Move from reference to reference . . . . .	1185
	Start the Surfer . . . . .	1185
	Continue a previous surf session . . . . .	1186
	Move between drawings . . . . .	1189
	Plot one or more drawings . . . . .	1190
	Project-wide utility . . . . .	1193

Create a project-wide script file . . . . .	1195
Renumber Ladder References . . . . .	1195
Project-wide update or retag . . . . .	1196
Track drawing changes . . . . .	1199
Translate description text . . . . .	1202
Publish to the Web . . . . .	1204
Publish to DWF . . . . .	1207
Title Block Utility . . . . .	1208
Title block . . . . .	1208
Title Block utility setup . . . . .	1210
Title Block setup overview . . . . .	1210
WD_TB attribute method . . . . .	1216
WDT file method . . . . .	1218
Title Block Update . . . . .	1220
Customize LINEx Labels . . . . .	1224
Map AutoLISP values to the title block . . . . .	1226
Drawing template . . . . .	1228
<b>Chapter 16 Icon Menus . . . . .</b>	<b>1231</b>
Overview of the Icon Menu Wizard . . . . .	1231
Add a new icon to the menu . . . . .	1232
Edit the properties of an existing icon in the menu . . . . .	1234
Use alternate icon menus . . . . .	1259
Modify Icon Menu File Directly . . . . .	1260
Overview of the icon menu file . . . . .	1260
<b>Chapter 17 BOM and Catalogs . . . . .</b>	<b>1265</b>
Catalog database . . . . .	1265
Catalog table naming conventions . . . . .	1265
Family tables in the default_cat.mdb . . . . .	1267
How to install additional manufacturer content . . . . .	1273
Overview of the catalog database table structure . . . . .	1274
Overview of the _LISTBOX_DEF catalog database table . . . . .	1277
Create a project-specific catalog database . . . . .	1279
Catalog Assignment . . . . .	1281
Assign catalog information to components . . . . .	1281
Copy catalog assignments from component to component . . . . .	1299
Show missing catalog assignments . . . . .	1303
Contact Quantity/Pin List Lookup . . . . .	1304
Use pin lists . . . . .	1304
Set pin list assignments for special uses . . . . .	1311
<b>Chapter 18 Reports . . . . .</b>	<b>1315</b>
Generate reports . . . . .	1315

Schematic Reports . . . . .	1399
Generate schematic reports . . . . .	1399
Panel Reports . . . . .	1427
Generate panel reports . . . . .	1427
Overview of format files . . . . .	1441
Run automatic reports . . . . .	1495
Export/Import spreadsheet data . . . . .	1499
Create user-defined attributes . . . . .	1508
Export to Autodesk Inventor Professional . . . . .	1512
Set up for export to Autodesk Inventor Professional Cable & Harness . . . . .	1512
<b>Chapter 19 Panel Layout . . . . .</b>	<b>1523</b>
Overview of panel layouts . . . . .	1523
Overview of footprint attributes/Xdata . . . . .	1524
Panel drawing configuration and defaults . . . . .	1527
Relationship between schematic drawings and panel layouts . . . . .	1531
Automatic schematic/panel update . . . . .	1531
Schematic and panel symbol relationship . . . . .	1532
Footprint/Terminal Insertion . . . . .	1534
Insert panel footprints from a schematic list . . . . .	1534
Insert panel footprints using vendor menus . . . . .	1544
Insert panel footprints using icon menu . . . . .	1547
Insert panel footprints manually . . . . .	1551
Insert panel footprints from a catalog list . . . . .	1555
Insert footprints from an equipment list . . . . .	1557
Insert a copy of a panel footprint . . . . .	1561
Use panel templates and assemblies . . . . .	1562
Footprint/Terminal Edit . . . . .	1565
Edit a footprint or panel terminal . . . . .	1565
Multiple Catalog . . . . .	1578
Copy code values to components . . . . .	1581
Delete Footprint . . . . .	1584
Layout Wire Connection Annotation . . . . .	1585
Add wire information to footprints . . . . .	1585
Lookup Files . . . . .	1592
Use the footprint lookup file . . . . .	1592
Item Numbers/Balloons . . . . .	1599
Add a balloon to a component . . . . .	1599
Resequencing item numbers . . . . .	1602
Fixing item numbers . . . . .	1605
Nameplates . . . . .	1608
Insert nameplates . . . . .	1608
Panel Leveling/Sequencing Tools . . . . .	1610
Remove sequencing assignments . . . . .	1610
Show sequencing assignments . . . . .	1611

	Swap terminal strip wire text . . . . .	1611
<b>Chapter 20</b>	<b>Conduit Tools . . . . .</b>	<b>1625</b>
	Overview of conduit tools . . . . .	1625
	Conduit Marker Intelligence . . . . .	1625
	Overview of conduit marker support files . . . . .	1632
	Generate a conduit marker report . . . . .	1633
	Generate a conduit routing report . . . . .	1635
<b>Chapter 21</b>	<b>Conversion Tools . . . . .</b>	<b>1637</b>
	Convert promis.e drawing files to AutoCAD Electrical . . . . .	1637
	Convert non-AutoCAD Electrical blocks . . . . .	1641
	Finish mapping values from non-AutoCAD Electrical blocks . . . . .	1642
	Convert text to an attribute . . . . .	1644
	Convert Arrows . . . . .	1646
	Convert non-AutoCAD Electrical arrows . . . . .	1646
	Overview of ECDS legacy conversion . . . . .	1647
	Tagging and Linking Tools . . . . .	1650
	Use tagging and linking tools . . . . .	1650
	Overview of block/attribute mapping . . . . .	1661
<b>Chapter 22</b>	<b>Miscellaneous Tools . . . . .</b>	<b>1667</b>
	Overview of power check tools . . . . .	1667
	Overview of pneumatic tools . . . . .	1670
	Insert hydraulic components . . . . .	1675
	Insert P&ID components . . . . .	1680
	Troubleshooting Tools . . . . .	1685
	Overview of real-time error checking . . . . .	1685
	Modify invisible data . . . . .	1694
<b>Chapter 23</b>	<b>Tutorials . . . . .</b>	<b>1697</b>
	Introduction . . . . .	1697
	Projects . . . . .	1699
	Projects - Introduction . . . . .	1699
	Working with projects . . . . .	1700
	Working with drawings . . . . .	1703
	Title Block . . . . .	1707
	Title Block - Introduction . . . . .	1707
	Title Block Utility . . . . .	1708
	Select method . . . . .	1710
	WD_TB attribute method . . . . .	1710
	Create a title block . . . . .	1710
	Title Block Setup - WD_TB attribute method . . . . .	1714

Create a drawing template . . . . .	1716
Use the template . . . . .	1718
Project description lines . . . . .	1719
Drawing values . . . . .	1719
Title Block Update . . . . .	1720
Customize project description labels . . . . .	1722
WDT file method . . . . .	1724
Create a title block . . . . .	1724
Title Block Setup - WDT file method . . . . .	1728
Create a drawing template . . . . .	1730
Use the template . . . . .	1733
Project description lines . . . . .	1733
Drawing values . . . . .	1734
Title Block Update . . . . .	1734
Customize project description labels . . . . .	1736
Wiring . . . . .	1738
Wiring - Introduction . . . . .	1738
About wires . . . . .	1739
Insert wiring . . . . .	1739
Trim a wire . . . . .	1741
Insert a single-phase ladder . . . . .	1742
Resequencing ladders . . . . .	1743
Schematic components . . . . .	1744
Schematic components - Introduction . . . . .	1744
About schematic components . . . . .	1745
Inserting components . . . . .	1746
Relocating components . . . . .	1750
Aligning components . . . . .	1754
Inserting components continued . . . . .	1754
Editing components . . . . .	1758
Linking components . . . . .	1761
Editing catalog information . . . . .	1763
Wire layers . . . . .	1767
Wire layers - Introduction . . . . .	1767
Creating a wire layer . . . . .	1768
Changing a wire layer assignment . . . . .	1769
Circuits . . . . .	1770
Circuits - Introduction . . . . .	1770
Move an existing circuit . . . . .	1771
Insert and configure a circuit . . . . .	1776
Save and insert a circuit . . . . .	1784
Insert a saved circuit using WBlock . . . . .	1790
Insert a one-line motor control circuit . . . . .	1792
Insert a one-line dual power feed circuit . . . . .	1797
Reference an existing circuit . . . . .	1800
Surf . . . . .	1804



Surf - Introduction . . . . .	1804
Moving between symbols . . . . .	1804
Block swap . . . . .	1807
Block swap - Introduction . . . . .	1807
Swapping components . . . . .	1807
PLC . . . . .	1809
PLC - Introduction . . . . .	1809
Inserting PLC modules . . . . .	1810
Using multiple insert component . . . . .	1814
Annotating PLC I/O descriptions . . . . .	1816
Schematic terminals . . . . .	1819
Schematic terminals - Introduction . . . . .	1819
About schematic terminals . . . . .	1820
Insert terminals . . . . .	1822
Multi-level terminals . . . . .	1825
Modify multi-level associations . . . . .	1827
Terminal Properties . . . . .	1830
Associate terminals . . . . .	1832
Wire numbers . . . . .	1834
Wire numbers - Introduction . . . . .	1834
About wire numbers . . . . .	1835
Inserting wire numbers . . . . .	1835
Inserting I/O based wire numbers . . . . .	1837
Deleting a wire number . . . . .	1839
Source signal arrows . . . . .	1840
Destination signal arrows . . . . .	1842
Panel layout . . . . .	1847
Panel layout - Introduction . . . . .	1847
Insert Footprint (Schematic list) . . . . .	1848
Adding nameplate footprints . . . . .	1858
Terminal Strip Editor . . . . .	1862
Generating reports . . . . .	1868
Generating reports - Introduction . . . . .	1868
Generating Bill of Material reports . . . . .	1869
Inserting Bill of Material tables into drawings . . . . .	1871
Changing format of Bill of Material report . . . . .	1872
Exporting Bill of Material report to spreadsheet . . . . .	1873
Connector diagrams . . . . .	1874
Connector diagrams - Introduction . . . . .	1874
About connector diagrams . . . . .	1875
Inserting connectors . . . . .	1875
Wiring connectors . . . . .	1879
Grouping wires . . . . .	1883
Modifying connectors . . . . .	1887
Adding wire numbers . . . . .	1891
Adding connector descriptors . . . . .	1892

P&ID and Hydraulic diagrams . . . . .	1894
P&ID and Hydraulic diagrams - Introduction . . . . .	1894
Setting Up Hydraulic Drawings . . . . .	1895
Inserting Hydraulic Schematic Symbols . . . . .	1896
Creating Pipes . . . . .	1900
Completing the Hydraulic Drawing . . . . .	1905
Setting Up P&ID Drawings . . . . .	1912
Inserting P&ID Schematic Symbols . . . . .	1916
Creating Pipes . . . . .	1919
Symbol Builder . . . . .	1922
Symbol Builder - Introduction . . . . .	1922
Creating custom symbols . . . . .	1923
Adding attributes . . . . .	1924
Adding wire connections . . . . .	1927
Saving the symbol . . . . .	1930
Migration of AutoCAD Data . . . . .	1931
Migration of AutoCAD Data - Introduction . . . . .	1931
About Tagging and Linking Tools . . . . .	1932
Exploding Block and Attributes . . . . .	1932
Tagging Schematic Components . . . . .	1934
Linking Schematic Attributes . . . . .	1935
Adding Wire Connections . . . . .	1938
Adding Geometry . . . . .	1941
Tagging and Linking Panel Components . . . . .	1942
Updating Panel or Schematic Components . . . . .	1944
Interoperability: Inventor and AutoCAD Electrical . . . . .	1946
Introduction . . . . .	1946
Introduction (continued) . . . . .	1947
Part 1: 2D to 3D . . . . .	1948
Rename component tags . . . . .	1949
Export to XML . . . . .	1951
Set the project . . . . .	1951
Open the dataset . . . . .	1952
Add harness segments . . . . .	1955
Add harness segments (continued) . . . . .	1958
Import the AutoCAD Electrical data . . . . .	1961
Issues . . . . .	1962
Assign missing RefDes . . . . .	1963
Finish the Import . . . . .	1966
Route the wires into the harness segments . . . . .	1966
Part 2: 3D to 2D . . . . .	1967
Create wires . . . . .	1970
Create Wires (continued) . . . . .	1971
Route wires . . . . .	1972
Export to XML . . . . .	1973
Import the Inventor data . . . . .	1973

	Summary . . . . .	1977
<b>Chapter 24</b>	<b>Advanced Productivity . . . . .</b>	<b>1979</b>
	Set up peer-to-peer component relationships . . . . .	1979
	Create automated pin assignments . . . . .	1981
	Set up AutoCAD Electrical for multiple users . . . . .	1984
	Show source and destination markers on cable wires . . . . .	1989
	Use the PLC Database File Editor . . . . .	1996
	Customize Circuit Builder . . . . .	2005
	Circuit Builder overview . . . . .	2005
	Circuit Builder spreadsheet . . . . .	2006
	Circuit Builder drawing templates . . . . .	2010
	Circuit Builder database . . . . .	2015
	Add a new circuit . . . . .	2032
	Circuit Builder - How to . . . . .	2043
	Overview . . . . .	2043
	Build your own symbols . . . . .	2082
	Build your own symbols . . . . .	2082
	Add your own symbols, circuits, and commands to the icon menu . . . . .	2112
	Configure projects for various drawing standards . . . . .	2119
	Use Autodesk Vault with AutoCAD Electrical . . . . .	2127
<b>Chapter 25</b>	<b>AutoCAD Electrical Command . . . . .</b>	<b>2135</b>
	AutoCAD Electrical Commands . . . . .	2135
	<b>Index . . . . .</b>	<b>2149</b>



# AutoCAD Electrical What's New

# 1

## Overview of AutoCAD Electrical Help

The AutoCAD Electrical Help system is a browser-based system available through context-sensitive links or by accessing it through the Help menu or icon. Key features of the Help system include:

- There is on-demand access from the F1 function key, ribbons, dialog boxes, and the command line.
- Navigation tabs in each topic link to related procedures, references, and concepts.
- The Help menu gives you access to AutoCAD Electrical Help, AutoCAD Electrical Launchpad, the New Features Workshop and other resources.

### What are ways to gain access to Help?

You can get help about a command while you are using it.

**Help Button in ribbon environment** Select the Help icon in the upper right. Select the drop-

down arrow to display a menu of help options.



**Help Menu**

From the menu bar, select Help ► Electrical Help Topics to view the AutoCAD Electrical Help home page.

**Press F1**

- At the command prompt, press F1 to open the topic for the active tool.

- In a dialog box, press F1 to open the Reference topic for the active tool.

#### Help button

In a dialog box, click Help to open the Reference topic for the active tool.

### How is Help organized?

Most of the subjects in the Help system have three topic types: Procedure, Reference, and Concept. Every Help topic selected from a menu has a tab row above the topic title. You can click a tab to go to the other available topic types.

- **Procedure** topics provide step-by-step procedures for accomplishing AutoCAD Electrical tasks.
- **Reference** topics offer detailed descriptions of elements in the dialog box.
- **Concept** topics provide conceptual information about tools and tasks and can explain related concepts.

The titles of Help topics are designed to tell you the information they contain:

- Procedure topics start with an action word, for example, "Create projects."
- Reference topics have the names of the dialog box as their titles.
- Concept topics typically start with the words "Use" or "Overview of."

### How do I get around in the Help system?

When you start the Help system, the first thing you see is the AutoCAD Electrical Help home page.

#### Navigation bar

At the top of every Help window is a navigation bar with icons. The left-most icon is either Show or Hide, which opens or closes the navigation pane of the Help window. The navigation pane has tabs for Table of Contents, Index, Search, and Favorites.

#### Table of Contents

Presents an overview of the available documentation in a list of topics and subtopics. Provides a structure so you can always see where you are in Help and quickly jump to other topics. Click AutoCAD Electrical Command Listing

for an alphabetical list of AutoCAD Electrical tools found in the menu and toolbars.

**Index**

You can enter a word in the box to locate the term in the alphabetical index. Double-click the term to display the topic, or if multiple topics, to open a list of topics found.

**Search**

Enter a search word in the box, and click List Topics to view a list of topics that contain the search word anywhere in their content. Click a title, and then click Display (or double-click a title) to open the topic.

**Favorites**

With a topic visible in the Help window, click the Favorites tab and then click Add to add the current topic to a list of favorites. To remove a topic from the list, select the topic in the list, and then click Remove.

**How do I learn the product?**

Training programs and products from Autodesk help you learn the key technical features and improve your productivity. For the latest information about Autodesk training, visit <http://www.autodesk.com/training> or contact your local Autodesk office.

The Autodesk Authorized Training Center (ATC) network delivers Autodesk-authorized, instructor-led training to design professionals who use Autodesk software. Autodesk Authorized Training Centers use experienced and knowledgeable instructors. More than 1,200 ATC sites are available worldwide to meet your needs for discipline-specific, locally based training.

To find a training center near you, contact your local Autodesk office or visit <http://www.autodesk.com/atc>.

**Use AutoCAD Electrical Help**

AutoCAD Electrical has various learning tools to assist you, whether you are a newcomer or an experienced CAD user.

**To gain access to Help**

Use any of the following methods to gain access to Help.

- Select the Help icon in the upper right or select the drop-down arrow to display a menu of help options. 

- Select Help ► Electrical Help Topics from the menu bar, and then browse to the desired topic. You can use the tabbed pane to access the Index, Search, or Table of Contents.
- Press F1 to open the Procedure or Reference Help topic for the active command.
- In an open dialog box, press F1 or click Help to open the Reference topic for the active command.

### To customize Help

Use any of the following methods to customize Help.

- Click the Hide or Show button in the Help toolbar to control the visibility of the tabbed pane beside the content window.
- To add a topic to the Favorites tab, select a Help topic, click the Favorites tab, and then click Add. To delete a topic from the Favorites tab, select the topic in the list, and then click Delete.

### To search Help

Another method for finding Help topics is to use the Search tab.

- 1 Click Show in the browser toolbar if the tabbed navigation pane is not displayed.
- 2 Click the Search tab.
- 3 Enter text in the search text box, and then click List Topics. Use quotation marks ( " ") around the search criteria to search for a string. Use an asterisk (\*) before or after text as a wildcard.
- 4 Double-click a topic or select a topic, and then click Display to show the topic.
- 5 You can also select one or more of the following Search options to limit the results.
  - Search previous results
  - Match similar words
  - Search titles only



- 6 Use operators to refine your Search criteria further. Click the right arrow next to the search text box, and then select one of the following operators.
  - **AND** Use AND to search for topics with more than one set of your search criteria.
  - **OR** Use OR to search for topics with at least one of your search criteria.
  - **NEAR** Use Near to search for specified text within close proximity to each other.
  - **NOT** Use NOT to search for topics that do not include your search criteria.

### To print Help

You can print a single file or you can print sections of the Help.

- 1 In the Help Contents tab, right-click a heading and select Print.
- 2 Select whether to print the selected topic or the selected heading and all subheadings.

---

**NOTE** You can also print a single topic by right-clicking in the file and selecting Print.

---

- 3 Click OK.

If you want to print the entire Help system, in the Contents tab, right-click AutoCAD Electrical Help and select Print. Select the option to print the selected heading and all subheadings and click OK.

### To find out What's New about AutoCAD Electrical

What's New topics describe the new functionality in the most recent AutoCAD Electrical release.

- 1 Click Help ► AutoCAD Electrical Help. In the AutoCAD Electrical Help, click What's New from the Table of Contents.

You can also open the What's New by selecting Help ► Display Launchpad. Click What's New on the AutoCAD Electrical Launchpad.
- 2 Browse to a feature you want to learn about.
- 3 Click More Information to learn more about the feature.

### To get started with AutoCAD Electrical

- 1 Select the Help drop-down arrow in the upper right to display a menu of help options. 
- 2 Select Learning Tools ► Launchpad.  
The AutoCAD Electrical Launchpad screen appears. The Launchpad has two sections. The top section is for first-time users. It has links to white papers, the Tutorials, and the AutoCAD Electrical discussion group. The bottom section has links to places for additional information about AutoCAD Electrical. You can find out what is new in the current release, link to the Advanced Productivity home page, and find out more about additional Autodesk products.
- 3 Click Tutorials on the AutoCAD Electrical Launchpad.

## Join the Customer Involvement Program

### **You are invited to participate in helping guide the direction of Autodesk design software.**

If you participate in the Customer Involvement Program, specific information about how you use AutoCAD Electrical is forwarded to Autodesk. This information includes what features you use the most, problems that you encounter, and other information helpful to the future direction of the product.

See the following links for more information.

- Learn more about the Autodesk Customer Involvement Program: <http://www.autodesk.com/cip>
- Read the Autodesk Privacy Statement: <http://www.autodesk.com/cipprivacy>

When you join, you will be able to view reports that can help you optimize your use of AutoCAD Electrical.

### To turn the CIP on or off

- 1 On the InfoCenter toolbar, to the right of the Help button, click the drop-down arrow.
- 2 Click Customer Involvement Program.

- 3 In the Customer Involvement Program dialog box, choose whether you want to start or stop participating.
- 4 Click OK.

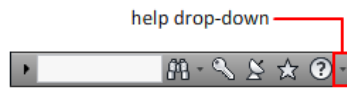

## What's New in AutoCAD Electrical 2011

### Catalog Lookup

The catalog lookup user-interface enhancements include:

- Control which fields are displayed and the field order in the catalog lookup dialog box.
- Filter catalog records by selecting existing values from any of the catalog fields.
- Search for a catalog record based on a value you supply, including wildcards, for any one of the catalog fields.
- Sort catalog records by clicking the column header of any of the displayed fields.
- BOM details displayed on the main dialog box (formerly called Catalog Check).
- Ability to define a default filter value for any catalog field using the expanded `_LISTBOX_DEF` table in the catalog database.
- Dialog box tooltips describing the function of each control on the dialog box.

[For More Information](#) on page 1285

### Import Wire Type

Wire Types are defined on a per-drawing basis. You can import wire types from an existing drawing or template to another drawing. Use the Import button on the Create/Edit Wire Type dialog box to import wire types to the active drawing. Use the Project-wide Utilities to import wire types to a set of project drawings.

[For More Information](#) on page 903

### **Item Numbering enhancements**

Item numbering now supports fixed item numbers on panel components. If Resequence Item Numbers is run later on, fixed item numbers do not change.

Resequence item numbers based on the manufacturer values of the components. Select the manufacturers from a list of values used in the project. Only item numbers on components with selected manufacturer values change.

Define the resequence order based on the manufacturer values of the components. Use the Move Up and Move Down buttons to change the order of the manufacturers for processing by the Resequence Item Numbers command.

[For More Information](#) on page 1604

### **Project-specific catalog database**

Create a catalog database containing only the catalog values used in the project drawings. This command takes the default\_cat.mdb database and removes all catalog values not used in the project drawings. Use this smaller catalog database to:

- Send to a client with the finished project.
- Limit future catalog selections to components used in the project.

[For More Information](#) on page 1280

### **Location Box enhancements**

When you insert a Location Box, a check box on the Location Box dialog box indicates whether to update the location and installation values for the parent components that fall within the new location box.

AutoCAD Electrical commands are now location box aware. If you insert or move schematic parent components into an existing location box, location and installation values update to match the location box. If you move schematic parent components out of a location box, choose whether to update component values to match the drawing defaults.

---

**NOTE** Circuit commands do not update components within the circuit due to placement within an existing location box.

---

[For More Information](#) on page 889

### Suppress wire collision check

Turn the collision checking off temporarily when inserting wires. Default behavior is to route around a component when routing a wire from one specified location to another. If you want the wire to break across any components encountered as you insert the wire, turn the collision checking off.

[For More Information](#) on page 913

### Learning Solutions

- Getting Started exercises added to the online Help.
- Title block tutorial added detailing how to create a template, create a title block, and define the title block mapping for a title block update.
- Cable Design Interoperability - AutoCAD Electrical and Inventor tutorial added with exercises in both environments.

[For More Information](#) on page 1697

## What's New in Previous Releases

The following chart shows which features were added or enhanced in past releases of AutoCAD Electrical. Click the 'x' for detailed information on what was added or enhanced for a particular release.

Feature	2008	2009	2010	2011
64-bit AutoCAD Electrical	<a href="#">X</a> on page 18			
Autodesk Inventor Professional Integration				<a href="#">X</a> on page 9
Autodesk Vault Integration		<a href="#">X</a> on page 23		
Catalog Content Updates	<a href="#">X</a> on page 18			
Catalog Lookup User-interface				<a href="#">X</a> on page 7

Feature	2008	2009	2010	2011
Catalog Database Creation				X on page 8
Circuit Builder		X on page 19	X on page 26	
Direct Wire Sequencing	X on page 15			
DWG Product Recognition	X on page 18			
Electrical Audit			X on page 28	
Help Updates	X on page 19	X on page 25	X on page 28	X on page 9
Icon Menu Wizard Enhancements	X on page 15			
Improved Performance	X on page 18			
InfoCenter	X on page 19			
Insert Components from a Menu	X on page 14		X on page 27	
Inserting Spare Terminals	X on page 16			
Installer Improvements	X on page 18			
Item Numbering		X on page 21		X on page 8
Location Box				X on page 8

<b>Feature</b>	<b>2008</b>	<b>2009</b>	<b>2010</b>	<b>2011</b>
Migration Utility		X on page 21		
Multi-Level Terminals	X on page 17	X on page 20		
One-Line Support			X on page 27	
Pin List Data Management	X on page 18			
PLC I/O Import/Export	X on page 13			
PLC I/O Libraries	X on page 13			
Power Feed Support			X on page 26	
Project Manager		X on page 23		
Ribbon Interface			X on page 25	
Spreadsheet to PLC I/O Utility Enhancements	X on page 13	X on page 22		
Stand-alone Cross-reference		X on page 24		
Surfable Reports	X on page 14	X on page 22		
Surfing		X on page 22		
Symbol Builder		X on page 21		

<b>Feature</b>	<b>2008</b>	<b>2009</b>	<b>2010</b>	<b>2011</b>
Symbol Libraries			X on page 27	
Table Style Cross-reference Updates		X on page 22		
Terminal Jumpers	X on page 17	X on page 20		
Terminal Properties Database Editor	X on page 17	X on page 20		
Terminal Strip Editor	X on page 15	X on page 20		
Terminals		X on page 24		
User's Guide	X on page 19			
Wire Collision Avoidance				X on page 9
Wire Connection Improvements		X on page 23		
Wire Number Placement		X on page 23	X on page 27	
Wire Sequence Updates	X on page 15	X on page 24		
Wire Type Creation/Import				X on page 7



# What's New in 2008 Release

## **PLC I/O Import/Export**

You can now communicate your electrical designs between AutoCAD Electrical and Unity Pro from Schneider Electric. Employing the widely used XML language format, you can transfer design data back and forth while maintaining structure and organization.

Use the new Unity Pro Export to Spreadsheet tool to import Unity Pro XML export files. These files aid in the creation of PLC-style ladder drawings and panel layout drawings (in both vertical and horizontal format) in the active project. The Unity Pro export files also contain catalog information. You can reformat the files to generate an equipment list. The list can be used to create a rack layout drawing used in panel layouts or separate rack layout drawings.

Use the new Unity Pro Export tool to create a Unity Pro I/O variable file (\*.xsy) in the Unity Pro XML format from your AutoCAD Electrical drawings. The Unity Pro export file is generated from the PLC drawings and their respective PLC symbols.

[For More Information](#) on page 642

## **PLC I/O Libraries Enhancements**

You can quickly create PLC I/O drawings by selecting from a library of over 3,000 intelligent PLC I/O modules. These modules come from the most popular manufacturers in the industry.

## **Spreadsheet to PLC I/O Utility Enhancements**

You no longer have to create and save the starting drawing for the Spreadsheet to PLC I/O Utility tool. You can now define a starting drawing file name or start with the active drawing. Additional enhancements include:

- Default settings are now read automatically the first time you run the tool.
- You can select a settings file and make it the default.
- You can have the newly created drawings added automatically to the end of the active project.

[For More Information](#) on page 630

## Surfable Reports

When reports are placed into a drawing as a table, click various report cells to find the corresponding devices within the schematic or panel layout drawings in the active project.

When surfing on a table inserted by the Terminal Strip Editor, click the title cell to surf on the Tagstrip value. You can surf on the value even if the Tagstrip is not included in the title. If you select a cell that is not surfable (such as the Tag, Catalog, or Wire Number cell) the Tagstrip value is surfed for the terminal strip.

[For More Information](#) on page 1185

## Insert Component and Insert Footprint Enhancements

The Insert Component and Insert Footprint dialog boxes are updated to improve ease of use when selecting components to insert into your drawing. Enhanced dialog box controls include:

- **Menu tree structure**  
Displays the main menu and submenus from which you can freely navigate. Clicking the menus displays the corresponding menu icons in the Symbol Preview window. The menu is created by reading the \*.dat file defined in the Project Properties dialog box.
- **Symbol Preview window**  
Displays the symbol icons and submenu icons corresponding to the selected menu. Clicking an icon performs one of the following functions based on the icon properties as defined in the \*.dat file: insert a component or circuit, display a submenu, or execute a command.
- **Recently Used**  
Displays the last components inserted during the current editing session. The most recently used icon displays at the top. This list follows the view options setting in the symbol preview window. The total number of icons displayed depends on the value specified in the Display edit box.
- **View**  
Changes the view display for the Symbol Preview window and Recently Used window. The current view option is indicated with a check mark. Options include: Icon with text, Icon only, or List view.
- **Tooltips**  
When you move the cursor over an icon, the icon name and block/circuit/command names display as tooltip information.

### **Icon Menu Wizard Enhancements**

Use the Icon Menu Wizard to customize the icon menus easily. You can copy and paste icons from one submenu into another, drag and drop icons to place the icons that are commonly used at the top of the Symbol Preview window and the icons that are used less frequently at the bottom of the window, and create new icons to use when inserting components.

You can also easily modify the existing icon or menu properties like changing the name, image, or block name. Right-click the menu or icon on the Icon Menu Wizard dialog box and select Properties. The existing data is overwritten in the \*.dat file with the new changes.

[For More Information](#) on page 1231

### **Direct Wire Sequencing**

You can now use the Edit Wire Sequence tool to define additional direct-to-terminal wire connection sequences in schematic networks. For example, suppose one side of a schematic terminal is connected to three field devices. A specific wire connection sequence can be defined to force the connection reporting, but it is limited to reporting the terminal as a common connection point for only two of the three field devices. The third device must be reported as jumpered to one of the other two devices. With the new support for secondary direct-to-terminal sequences, the third field device can be sequenced directly to the terminal and the Wire From/To report shows all three field devices tied directly to the terminal.

[For More Information](#) on page 1029

### **Visual Wiring Sequence Indicators**

Once you define additional wire connection sequences, use the Show Wire Sequence tool to show the new sequencing graphically. When any changes are made to a wire sequence, the updated information is accurately reflected in the from/to wire list report.

[For More Information](#) on page 1030

### **Terminal Strip Editor Enhancements**

The Terminal Strip Editor provides an easy way to manage and edit terminals used throughout a project. You can now start designs with a terminal strip layout drawing representing the terminal strip. In the modified Terminal Strip Selection dialog box, select a terminal strip for editing. Alternatively, create a terminal strip definition in the project and maintain its properties in the graphical terminal strip layout drawing.

The Terminal Strip Editor dialog box now has an enhanced grid control with bolder grid lines that provide better visual definition for the terminal strip. Other enhancements to the dialog box include:

- The Terminal Pin (TPin) column is now “T.”
- The TERM column is now “Number” to indicate the terminal numbering, whether it is a wire number or user-defined number.
- The Function column is now “Installation.”
- A new column (on the far left side of the grid) indicates the level definition.
- Tooltip instructions display once you move your cursor over 1 of the tool buttons in the dialog box.
- There is better context menu support that is based on individual cells.
- The Preview tab is now “Layout Preview.”
- The Cable Preview tab is now “Cable Information.”

New tools are available on the Terminal Strip Editor dialog box. Use the tools to:

- create associations
- separate levels from a multiple level terminal block into separate terminal blocks
- reverse the left and right wiring information for a terminal
- edit terminal block properties such as the number of levels and number of wires per connection.

The Layout Preview tab of the Terminal Strip Editor dialog box was enhanced to allow table objects in AutoCAD to be inserted as a terminal strip. It allows for more accurate representations of what is in the Terminal Strip Editor, more flexibility with the style, and provides a means for automatic updating.

[For More Information](#) on page 1064

### **Inserting Spare Terminals**

Extra terminal block definitions and accessory information is now maintained and saved on the graphical terminal strip layout. You can insert spare terminals and have them accurately update the Bill of Materials as well as various terminal reports.

[For More Information](#) on page 1102

### **Multi-Level Terminals**

Multi-level terminal blocks are quickly becoming an industry standard. Using AutoCAD Electrical, you can define and manage the terminal numbers and levels as well as all connectivity information with no added complexity.

You can now associate schematic terminals to build a multi-level terminal block that is limited to the number of levels defined in the block properties. Use the new Add/Modify Associations tool to search project terminal strips for existing multi-level terminal blocks so that you can define and maintain terminal associations. Terminals must be in the same terminal strip and be in the same project to associate together. You can also remove a terminal from any multi-level relationship and copy terminal properties from one terminal symbol to another.

Associating schematic terminals combines the terminals into a single terminal block property definition. The number of schematic terminals that can be combined is limited to the number of levels defined for the block property. Terminal associations can also tie together a set of schematic terminal block symbols to one panel representation of a terminal footprint.

[For More Information](#) on page 1053

### **Terminal Properties Database Editor**

Terminal properties data is now managed based on manufacturer. Use the new Terminal Properties Database Editor tool to:

- select the manufacturer table to edit
- create a new table in the catalog database for the active project.

### **Terminal Jumper Support**

Use the new Edit Jumper tool to add, edit, or remove jumpers between terminals that share the same potential in a schematic drawing. You can display temporary line graphics between the primary terminal and secondary terminals within the same drawing.

Jumpers now display on the panel drawing so you have a visual representation of jumpers that appear on tabular terminal strips. Cells of a table row are joined with a graphical jumper that looks like two circles connected by a solid thick line. Three columns of jumpers are supported within a single jumper column in the table.

### **Pin List Data Management**

Pin list data is now managed based on manufacturer. Use the Pin List Database Editor tool to select the pin list table to edit or create a table.

The \_PINLIST table in the default\_cat.mdb file now uses a single PINLIST column and a single PEER\_PINLIST column. The continuation columns were removed.

[For More Information](#) on page 1305

### **Installer Improvements for Manufacturer Content**

You can now selectively install content based on manufacturer, reducing the size of the content databases and data redundancy. To later install content from another manufacturer, open the Add or Remove Programs tool in your Control Panel, select AutoCAD Electrical 2008, and click Change/Remove. Click Add/Remove Features, click Next on the first screen, and then select the manufacturers to install on the Manufacturer Contents Selection screen.

### **Catalog Content Updates**

AutoCAD Electrical ships with a catalog database of a manufacturer that contains over 350,000 components from the most popular vendors in the industry. These components provide a full spectrum of input and output devices including switches, sensors, lights, and numerous panel devices, such as wireway and panel enclosures.

### **Improved Performance**

Significant improvements in running commands that affect other drawings have dramatically improved the performance of AutoCAD Electrical 2008. Most notably, the Project Database Service (PDS) now only monitors the active project.

### **64-bit AutoCAD Electrical**

AutoCAD Electrical now ships in 64-bit and 32-bit versions. The 64-bit version supports the same functionality as the 32-bit version.

### **DWG product recognition**

Easily identify which Autodesk product created a DWG file and open the file with the application that owns the DWG file. For example, if the DWG file is owned by AutoCAD, double-clicking the file in Windows Explorer automatically opens the file in AutoCAD. When you move the cursor over a

DWG icon, the tooltip identifies which Autodesk product and version was used to create the DWG.

### **Parametric Twisted Pair Symbol Enhancements**

The icon menus are enhanced to include three new parametric twisted pair symbols. To insert a twisted pair symbol, click Components > Insert Component. On the Insert Component icon menu, click Miscellaneous and click Cable Markers.

### **User's Guide**

A User's Guide for AutoCAD Electrical is now available in PDF format. It is accessible from the Launchpad and the home page of the Help.

### **InfoCenter**

A new search engine, InfoCenter, is included on the title bar of the main AutoCAD Electrical window. It searches AutoCAD and AutoCAD Electrical Help systems to give you the most relevant information for any query you enter. You can filter content and add frequently used content to the Favorites section.

InfoCenter replaces the Communication Center. It provides notifications of software and content updates through a balloon notification mechanism. You can also publish internal content within your team, support RSS feeds, and easily provide feedback to Autodesk.

### **What's New for Previous Releases**

You can now quickly see which features were added or enhanced in past releases of AutoCAD Electrical. This PDF is accessible from the home page of the AutoCAD Electrical Help. Click the "x" for a particular feature to get more information about what functionality was added for that release.

## **What's New in 2009 Release**

### **Circuit Builder**

The Circuit Builder feature comes with many predefined motor control circuits. Insert a circuit by picking from the list of motors and selecting the location on your drawing. AutoCAD Electrical builds the selected circuit on-the-fly, matching the rung spacing, adding wiring between components, and annotating the circuit based on motor horsepower and industry standards.

Inserting a custom motor control circuit can also be as easy as a few mouse clicks. Select the options to define the circuit, such as breaker type, control circuitry and motor horsepower. Select the location for the circuit and a custom circuit is built based on the selected options.

You can customize the Circuit Builder feature to build your custom circuits. The feature uses a spreadsheet and drawing templates. The spreadsheet defines the available options for the circuit and the defaults for each option. The drawing template defines the placement for the individual components and the wiring.

[For More Information](#) on page 653

### **Terminal Strip Editor**

Enhancements to the Terminal Strip Editor make it a more comprehensive utility.

- Controls added to insert, edit, and delete jumpers inside Terminal Strip Editor.
- Internal jumper support for multi-level terminals based on the catalog assignment, as defined in the TERMPROPS table, or block properties.
- Columns added for jumper display. Internal jumpers are shown on the left of the terminal number as squares. Add-on jumpers are shown on the right as circles.
- Option to launch Automatic Wire Numbering once terminal updates are complete if jumper changes are made.
- New Jumper Chart option to display graphically all jumpered terminals in a table object placed on a drawing. These jumper charts are updated automatically when the graphical terminal strip is updated.
- Additional control over the jumper circles in the table object and jumper chart.
- Options to split the table object into multiple sections are provided. Controls for number of rows per section, number of sections per drawing, section placement, offset distance, and offset direction are available. Use the Drawing to Preview slider to preview each drawing.
- The Table Preview now takes angle and scale into account.
- An additional Preview is available while defining table settings. This preview reflects all table settings include drawing template. The preview includes a list of drawings if the settings result in multiple drawings.



[For More Information](#) on page 1064

### **Symbol Builder**

The Symbol Builder now takes advantage of the block editor environment. All the block editor features are available along with AutoCAD Electrical dialog boxes. It is easy to adjust the graphics of the component and add the necessary attributes for each type of AutoCAD Electrical component.

Start with a template supplied with attributes for the specific component type you want to create. All necessary attributes are immediately available for insertion along with any optional attributes. Drag them from the dialog box into your symbol.

When your symbol is ready, save it using the suggested symbol name following the AutoCAD Electrical naming standards, or enter your own symbol name. Audit your symbol to see any potential issues with your symbol.

[For More Information](#) on page 339

### **Migration Utility**

The Migration utility replaces the Merge utility which dealt exclusively with the catalog database. The Migration utility lets you merge the catalog database and supports other files types and settings, including the environment file, icon menu files, lookup database files, table styles drawing, user circuits, recent projects, and so on. Some file types allow you to merge the default AutoCAD Electrical file and your custom file. Other file types allow you to keep your custom file or overwrite it with the default AutoCAD Electrical file.

Select to migrate from a specific AutoCAD Electrical release. The existing files are found and listed for migration selection. Select which files to migrate, define the migration options, and your files from a previous release are ready for the latest AutoCAD Electrical release. Save the migration settings to use at a later time or to repeat the migration for another user or computer.

[For More Information](#) on page 123

### **Item Numbering**

You can now assign an item number on a per part basis. Each multiple catalog assignment can receive its own item number. Set the item numbering options for a project:

- 1 Right-click on the project name in Project Manager.
- 2 Select Properties.

- 3 Select the Components tab.
- 4 Click Item Numbering.
- 5 Click Per-Part Number Basis (excluding ASSYCODE combinations).
- 6 Click OK.

---

**NOTE** An item number can be assigned to the main catalog entry and any multiple catalog entries. It cannot be assigned to a catalog entry based on an assembly code.

---

The Insert Balloon feature supports multiple balloons per component. If a component carries multiple item number assignments, multiple balloons are inserted automatically. When an item number is modified or removed, the item balloon is updated or deleted.

[For More Information](#) on page 211

### **Surfing**

The ability to surf on an item number was added. Right-click an item balloon and select surf, or type the item number in the Surf dialog box. You can also surf on an item number in a report table. Run the Surf command and click the item number text in the report table.

[For More Information](#) on page 1187

### **Cross-referencing**

The graphics used to represent each contact type in the table cross-reference style are now customizable. A graphic drawing (.dwg) file is assigned to a specific contact block file name through a new cross-reference mapping table in the catalog lookup database. The assigned graphic drawing file is inserted as a block in the table cell in the TYPE column.

[For More Information](#) on page 228

### **Spreadsheet to PLC/IO**

You can now direct the Spreadsheet to PLC/IO utility to start a new drawing before generating the next module. Enter the keyword, NEW\_DWG, in the CODE column of the spreadsheet at the point where you want to start a new drawing. AutoCAD Electrical creates the drawing before generating the next module in the spreadsheet.

You can now predefine other attributes on the module like the inline device fields. For example, you want a module to have a Rack value of “2”, an Installation value of “MACH1”, and a Rating2 value of “Hazardous Duty”. In the spreadsheet, in the RACK column, enter “2;INST=MACH1;RATING2=HAZARDOUS DUTY”. When this module is generated these extra attribute values are assigned.

[For More Information](#) on page 626

### **Vault - Title Block Update**

The project description values in Vault can now be written back to AutoCAD Electrical drawings. Assign these values to the AutoCAD Electrical project description values. Project descriptions can be used in the AutoCAD Electrical title block update and the drawing list report. If the project descriptions are out of date when these features are used, you are prompted to import the Vault values in to the project descriptions.

### **3-Phase Wiring**

Connecting the 3-phase wiring to the motor symbol is now automatic. When you insert a motor symbol and 3-phase wiring is already present, place the symbol on or near the wires. The wires are angled and trimmed to meet the motor symbol.

---

**NOTE** For pre-2009 symbols, add a default attribute prompt value “X0STRETCH” to the X0TERMxx attributes.

---

### **Flip Component**

When you use the Flip Component feature, existing dashed link lines are recalculated and reinserted if necessary.

### **Project Manager**

You can now right-click the active project and select Close. The active project is closed, removed from the list, and the next project becomes the active project.

### **Toggle Wire Number**

When you toggle a wire number from above or below the wire to an in-line wire number, the number keeps its original center point, rather than centering it on the wire.

### **Trim Wire**

You can now use the dynamic pan and zoom while using the Trim Wire command. Start the command and select the Fence option. Select the first fence point and pan the drawing to select the next fence point. All wires are trimmed that cross the fence rather than just the wires on the screen.

### **Edit Wire Sequence**

The Edit Wire Sequence command remains active until you choose to exit the command by not selecting a wire. This feature makes it more efficient to assign a wire sequence to multiple wire networks.

### **Cable Conductor Table**

Adding a cable with many conductors is more efficient with the Alt+A hot key. Once you type in the conductor color, press Alt+A to add the conductor to the list.

### **COPYTAG for Terminals**

Terminals now support the COPYTAG attribute. COPYTAG is the optional TAG copy attribute. When AutoCAD Electrical updates a TAGSTRIP attribute, it also looks for and updates any COPYTAG attributes present on the symbol with a copy of the TAGSTRIP text. A special replaceable parameter, "%T", can be encoded onto the prompt value of the COPYTAG attribute definition. This replaceable parameter allows for adding a suffix and/or prefix to the TAGSTRIP text. If you need more than one extra TAGSTRIP copy on a symbol, name the attributes COPYTAG01, COPYTAG02, and so on.

### **Stand-alone Cross Reference**

The DESC1 attribute is now supported on stand-alone cross-reference symbols. You can add a value to this attribute in the Insert/Edit Stand-alone Signal/Destination dialog boxes. The description field is an available field in the Stand-alone cross reference report.

### **Export to Spreadsheet**

The option to export information from parent components only was added.

### **Catalog Content Updates**

Pneumatic catalog content was added to the catalog database of over 350,000 components from the most popular vendors of the industry. Additional catalog content for terminal blocks, PLC, and limit switches, was added.

### Help Updates

The New Features Workshop provides an outline and graphical view of new features this release.

A symbol library preview guide lists the library symbols supplied with AutoCAD Electrical.

[For More Information](#) on page 361

### Toolbar Tooltips

Some of the commonly used AutoCAD Electrical commands now provide an additional level of information in the tooltip. Pause the mouse over the command icon. The first level of information for that command is displayed. Continue to pause the mouse over the command icon and the next level of information is displayed in the tooltip. For more information about any command, press the F1 key while the tooltip is displayed.

## What's New in 2010 Release

### Ribbon Interface

To provide easy access to AutoCAD Electrical commands, a ribbon interface is now available. The ribbon layout is based on workflow and function. See the Help topic, Ribbon Interface, for more information on the ribbon layout.

[For More Information](#) on page 29

### Workspaces

AutoCAD Electrical provides three predefined workspaces.

- ACADE & 2D Drafting & Annotation - ribbons that provide the AutoCAD Electrical tools, and the AutoCAD 2D Drafting and Annotation tools.
- ACADE & 3D Modeling - ribbons that provide the AutoCAD Electrical tools, and the AutoCAD 3D Modeling tools.
- AutoCAD Electrical Classic - toolbars and pull down menus that provide the AutoCAD Electrical tools and AutoCAD tools.

To switch to another workspace, you can select the Workspace icon  on the status bar.

### **Circuit Builder goes green**

Circuit Builder now provides engineering analysis/green calculations in the area of power conductor size versus energy losses. Designing to meet minimum code requirements can conflict with green design.

During the code requirements analysis, Circuit Builder displays parallel energy loss calculations so you can make better green design decisions. For example, suppose you must oversize the conductors for a motor to reduce conductor heating losses. This action results in a higher initial cost. But this higher cost can potentially be recovered many times over in reduced energy losses in the wiring over the lifetime of the installation.

[For More Information](#) on page 712

### **Circuit Builder - power feed support**

Circuit Builder now provides power feed circuits for insertion.

- Option to add a source arrow symbols at end of the power feed bus.
- Option to add a generic load box representation at the end of the power feed bus.
- Supports defining a user-created load symbol, for example a variable speed drive symbol, for insertion at the end of a power feed bus.
- Support for adjusting the load representation based on the rung spacing.

[For More Information](#) on page 693

### **Circuit Builder - additional features**

- Wire conductor sizing based upon electrical code requirements.
- Support for split-parallel conductor sizing is available. You can choose to substitute multiple, smaller diameter conductors to meet the equivalent ampacity requirement of a single, large diameter conductor.
- Fuse, breaker, disconnect switch, and overload calculations based upon electrical code requirements.
- Circuit Builder can be set up to predefine motor description text, installation, location, and text description for individual components in the circuit.
- Insert a new circuit and reference an existing circuit. This option can transfer the values from the existing circuit to your new circuit.

- Electrical standards database editor to view, modify, and expand the ace\_electrical\_standards.mdb file.

[For More Information](#) on page 653

### **Motor control one-line circuits**

AutoCAD Electrical now provides library support and software support to create motor control one-line diagrams that link back to other drawing types in a project drawing set.

- New motor control one-line symbol library accessible from the icon menu.
- Circuit Builder helps you build motor control one-line circuits dynamically. You can design one-line circuits, with component values and wire sizes, to conform to a given electrical code.
- One-line component symbols can be related to parent/child counterparts on the schematic and panel layout drawings within a project. You can surf between one-line and related components, and all related components update when one is modified.
- Tagging of schematic or panel components using existing commands can reference a pick list that includes components pulled from the one-line diagrams.
- Certain schematic reports have a new category option. You select the category, for example One-Line, and the data is filtered based on that category. It can also be used to filter a report for Hydraulic, P&ID, or Pneumatic components.

[For More Information](#) on page 301

### **No wire numbering option for wire layers**

Wire layers now have a “no wire numbering” option. These wires behave normally for inserting, breaking, and scooting components, and show up in the Wire From/To report.

The Insert Wire Numbers command follows these rules:

- If **all** wires in the network are on layers set “No” for Wire Numbering, no new wire number is inserted.

- If **any** wire in the network is on a layer set “Yes” for Wire Numbering, the existing non-fixed wire number is updated, or a new wire number is inserted.
- If a wire network already has a non-fixed wire number, it is updated regardless of the Wire Numbering setting. Use the Delete Wire Numbers command to remove the wire number.

[For More Information](#) on page 266

### **Electrical Audit**

The Electrical Audit can now display the results for the active drawing only. Run the Electrical Audit, click the Active Drawing button and quickly see the issues for this drawing only. Open another drawing and the dialog box updates to display the results for the newly opened drawing. The active drawing must be part of the active project.

[For More Information](#) on page 1689

### **Help Updates**

Reference topics that show command access now include the following features:

- Command line access
- Ribbon access
- If the location of a command is changed, ribbon and menu access to the command are updated in the Help system to reflect the new location.

---

**NOTE** This dynamic update only works when the Help is used within AutoCAD Electrical.







---



# Ribbon Interface





## Project tab









### Project Tools panel









	Command	Description
	Project Manager AEPROJECT	Lists the drawing files associated with each open project. Use this to add new drawings, reorder drawing files, and change project settings. You cannot have two projects open in the Project Manager with the same project name.
	Copy Project AECOPYPROJECT	Copies an existing project to a new name and creates renamed copies of the drawing files.
	Delete Project AEDELETEPROJECT	Deletes a project and provides the option to also delete the drawing files in the project. This is permanent and cannot be undone.
	Zip Project AEZIPPROJECT	Creates a zip file of the .wdp file for the active project and one or more drawing files it references. The zip file can optionally include a copy of the temporary database file for the project.
	Project-Wide Update/Re-tag AEPROJUPDATE	Updates component tags, wire numbers, ladder references, and select drawing settings.
	Project-Wide Utilities AEUTILITIES	Updates wire numbers, component tags, and attribute text. Allows user-defined scripts to be applied project-wide.



Command	Description
 Mark/Verify DWGs AEMARKVERIFY	<p>Places an invisible mark on each component before sending the drawings to a client. When the drawings are returned, a list is generated that includes any components or wire numbers that have been modified, edited, or copied.</p> <p><b>NOTE</b> This command writes information to the project database file that is used to check for deleted components. Your drawings must be named and part of the active project to use this command.</p>

## Other Tools panel

Command	Description
 Surfer AESURF	<p>Moves from reference to reference across the project drawing set. A new window opens and the original window closes when Surf is selected unless you hold the Shift key while running the command.</p>
 Continue Surfer AESURFCONT	<p>Continues a previous surf session from the point where you left off.</p>
 Previous DWG AEPREV	<p>Loads the drawing listed above the current drawing in the project explorer, and closes the current drawing.</p>
 Next DWG AENEXT	<p>Loads the drawing listed below the current drawing in the project explorer, and closes the current drawing.</p>
 Migration Utility AEMIGRATION	<p>Migrate database and support files from a previous version of AutoCAD Electrical to the current release.</p>





	Command	Description
	Language Conversion AELANG	Translates component description text from one language to another. Description text and switch position text is processed on schematic and panel components.
	Edit Language Database AELANGDB	Opens the current language table for review and modification. The default table is wd_lang1.mdb.
	Title Block Setup ASETUPTITLEBLOCK	You can link some AutoCAD Electrical project description data entries and some of the drawing values to the attributes in the title blocks. There are two methods, an attribute mapping file or a mapping attribute embedded on the title block.
	Title Block Update AEUPDATETITLEBLOCK	Automates updating title block information for the current drawing or the entire project drawing set. Project and drawing specific settings are linked to one or more attributes contained in the title block.
	IEC Tag Mode Update AEUPDATEIECTAG	Updates component tagging based on a change in the IEC tagging mode.
	Update to New WD_M Block, Values, Layers AESWAPWDM	Replaces the schematic wd_m.dwg block in the current drawing with a newer copy, and converts to the newer configuration values and layers.
	Update to New WD_M Block, No changes AESWAPWDM- NOCHANGE	Replaces the schematic wd_m.dwg block in the current drawing with a newer copy, but keeps existing configuration values and layer names.
	Update to New WD_PNL Block, Values, Layers AESWAPPNLM	Replaces the panel wd_pnlm.dwg block in the current drawing with a newer copy, and converts to the newer configuration values and layers.



	Command	Description
	Update to New WD_PN- LM Block, No changes AESWAPPN- LMNOCHANGE	Replaces the panel wd_pnlm.dwg block in the current drawing with a newer copy, but keeps existing configuration values and layer names.
	Update Symbol Library WD_M Block AECOPY2SYMLIB	Writes the attribute settings for the wd_m block in the current drawing to the wd_m.dwg drawing file in the symbol library.
	Settings List Utility AEDWGCFG	Reports the settings of each drawing in the project, and provides the means to edit the report and update the drawing properties with the edited values.
	Xdata List AELISTXDATA	Lists extended entity data, xdata, on a selected object.
	Xdata Editor AEXDATA	Allows display and edit of an object's "1000" type extended entity data (Xdata).
	Right Click Menu Off AEOFFRIGHTCLICKCON- TEXTMENU	Turns off the right-click menus in AutoCAD Electrical.
	Right Click Menu On AEONRIGHTCLICKCON- TEXTMENU	Turns on the right-click menus in AutoCAD Electrical.
	Add Catalog Table AEADDCATALOGTABLE	Adds a new, blank table to the catalog lookup database file.
	Create Project-specific Catalog Database	Creates a project-specific catalog database containing only the entries used in the project.

	Command	Description
	AECREATEPROJCATALOG	
	Move Objects to Layer AEMOVE2LAYER	Moves all objects on a layer in the active drawing to a different layer.
	PLC Database Migration Utility AEPLCMIGRATE	Adds the Category field to the PLC database tables. This field is used by the Spreadsheet to PLC I/O utility to determine module placement.

## Troubleshooting panel

The Troubleshooting panel is off by default.



	Command	Description
	Clean DWG Utility AECLEANDWG	Inserts a project drawing as an exploded block into a new, blank drawing.
	Command Trace On AEONLISPDEBUG	Turns on the display of a real-time listing of internal calls in AutoCAD Electrical.
	Command Trace Off AEOFFLISPDEBUG	Turns off the display of a real-time listing of internal calls in AutoCAD Electrical.
	MDB Command Trace On AEONMDBDEBUG	Turns on the display of error messages generated during temporary MDB file rebuild or freshen.



	Command	Description
	MDB Command Trace Off AEOFFMDBDEBUG	Turns off the display of error messages generated during temporary MDB file rebuild and freshen.
	Command Timer On AEONTIMER	Turns on the timer for command execution elapsed time.
	Command Timer Off AEOFFTIMER	Turns off the timer for command execution elapsed time.

## Schematic tab



### Quick Pick panel









The Quick Pick panel is off by default.

	Command	Description
	Relays AERELAYMENU	Activates the icon menu with the relay page displayed.
	Push Buttons AEPUSHBUTTONSMENU	Activates the icon menu with the push button page displayed.
	Selector Switches AESELECTORSWITCH-MENU	Activates the icon menu with the selector switch page displayed.







	Command	Description
	Limit Switches AELIMITSWITCHMENU	Activates the icon menu with the limit switch page displayed.
	Pilot Lights AEPILOTLIGHTSMENU	Activates the icon menu with the pilot light page displayed.
	Insert Saved Circuit AESAVEDCIRCUIT	Inserts a user circuit selected from on-screen icon menu.







## Insert Components panel



	Command	Description
	Insert Component AECOMPONENT	Inserts selected components from the icon menu onto the drawing.
	Insert Component (Catalog List) AECOMPONENTCAT	Inserts schematic symbols by choosing a catalog number or a component description from a user-defined pick list. The data displayed in this pick list is stored in a database in generic Access format. The file name is wd_picklist.mdb and can be edited with Microsoft® Access or from Add/Edit/Delete along the bottom of the pick list's dialog box. The AutoCAD Electrical normal search path sequence is used to locate this file.
	Insert Component (Equipment List) AECOMPONENTEQ	This spreadsheet organizes the selected user-created equipment list and presents the list in a pick list. As you pick an item from the pick list, the appropriate schematic symbol is found and inserted in the drawing at your pick point. You can open a comma-delimited file, Mi-

	Command	Description
		Microsoft® Excel® spreadsheet, or Microsoft Access database file for input.
	Insert Component (Panel List) AECOMPONENTPNL	Lists panel components extracted from your panel drawing, finds the appropriate schematic symbol, and inserts the schematic components at your pick point.
	Insert Terminal (Panel List) AETERMINALPNL	Lists panel terminals extracted from your panel drawing, finds the appropriate schematic symbol, and inserts the schematic terminals at your pick point.
	Circuit Builder AECIRCBUILDER	Build a motor control circuit dynamically.
	Recalculate Wire Size AEEDITWS	Displays Wire Size Lookup dialog box with previous calculated data for selected motor or power feed load representation.
	Multiple Insert (Icon Menu) AEMULTI	Inserts a series of similar components at fence crossing points with underlying wires.
	Multiple Insert (Pick Master) AEMULTIPICK	Inserts a copy of the selected component multiple times at each wire crossing and fence line intersection point.
	Insert WBlocked Circuit AEWBCIRCUIT	Inserts WBlocked circuitry (external drawing file) with automatic component tag update.
	Insert Saved Circuit AESAVEDCIRCUIT	Inserts a user circuit selected from on-screen icon menu.















Command	Description
	<p><b>Insert PLC (Parametric)</b> AEPLCP</p> <p>Generates PLC I/O modules on demand, in a variety of different graphical styles via a parametric generation technique. It is driven by a database file (ace_plc.mdb) and a handful of library symbol blocks.</p>
	<p><b>Insert PLC (Full Units)</b> AEPLC</p> <p>Inserts PLC I/O modules that are fixed library symbol blocks.</p>
	<p><b>Location Box</b> AELOCATIONBOX</p> <p>Draws a dashed box around selected components. A description can be assigned to the box, and components within the box can have their location and installation code(s) changed.</p>
	<p><b>Location Symbols</b> AELOCATIONSYMBOL</p> <p>Inserts location marks on symbols that are identified with location code in text form.</p>
	<p><b>Insert Connector</b> AECONNECTOR</p> <p>Generates a connector symbol from user-defined parameters. The symbol is created on the fly, and inserted as a block insert into your active drawing file. Since these are created on an as-needed basis, it eliminates the need for you to create and maintain a library of connector symbols.</p>
	<p><b>Insert Connector from List</b> AECONNECTORLIST</p> <p>Imports a connector wire list from another application, such as Autodesk® Inventor™ Professional Cable &amp; Harness.</p> <p><b>NOTE</b> If the AutoCAD Electrical drawing is missing one end of the connector or if a connection was not found, wiring information is displayed next to the pin and the information is written into a log file so you know AutoCAD Electrical was unable to resolve the wire connections in the drawing. The log file name is {drawing filename.LOG} and is found in the same folder as the drawing file.</p>







	Command	Description
	Insert Splice AESPLICE	Inserts a splice symbol selected from the on-screen icon menu.
	Link Components with Dashed Line AELINK	Draws a smart dashed line between stacked contacts of a multicontact component. When the dashed link line inserts, certain attributes automatically flip to invisible. Use the Attribute Hide command to turn the visibility of the selected attributes back on.
	Insert Reference Arrow - To AEREFARROWTO	Draws a dashed line from a component to a "To" arrow symbol.
	Insert Reference Arrow - From AEREFARROWFROM	Draws a dashed line from a component to a "From" arrow symbol.
	Insert Stand-Alone Cross-Reference AESAXREF	Inserts standalone cross-reference symbol (not tied to a wire). You use standalone cross-reference symbols just as you would wire source/destination arrow symbols but without the wires. Insert a source reference symbol, and then tie one or more destination reference symbols to it. These can be on the same drawing or scattered across the project drawing set.
	Insert Pneumatic Components AEPNEUMATIC	Inserts Pneumatic components from an on-screen icon menu. This icon menu can be modified, expanded, or replaced with your own custom menu. You can change the default icon menu using the Project Properties dialog box. Use the Icon Menu Wizard to easily modify the menu.







Command	Description
 Insert Hydraulic Component AEHYDRAULIC	Inserts hydraulic components from an on-screen icon menu. This icon menu can be modified, expanded, or replaced with your own custom menu. You can change the default icon menu using the Project Properties dialog box. Use the Icon Menu Wizard to easily modify the menu.
 Insert P&ID Component AEPID	Inserts P&ID components from an on-screen icon menu. This icon menu can be modified, expanded, or replaced with your own custom menu. You can change the default icon menu using the Project Properties dialog box. Use the Icon Menu Wizard to easily modify the menu.









## Edit Components panel







Command	Description
 Edit Component AEEDITCOMPONENT	Edits components, PLC modules, terminal, wire numbers and signal arrows.
 Add/Edit Internal Jumper AEINTERNALJUMPER	Adds, changes, or deletes internal jumpers on a selected component. When wire numbers are inserted, these internal jumpers are read and wire numbers are assigned accordingly.
 Fix/UnFix Component Tag AEFIXTAG	Toggles selected component tag between fixed and normal.
 Copy Catalog Assignment AECOPYCAT	Inserts or edits catalog part numbers onto the currently selected component or footprint.

	Command	Description
	Edit User Table Data AEUSERTABLE	Edits user-defined Xdata on component or wire numbers and populates the User table in project database file. You can add, edit, or remove free-form user data records attached to the selected block insert.
	Delete Component AEERASECOMP	Removes the selected component from the drawing. If you erase a parent schematic component, you have the option to search for related child components, surf to them, and delete them.
	Copy Component AECOPYCOMP	Inserts a copy of an existing component into the drawing and updates the component tags.
	Copy Circuit AECOPYCIRCUIT	Copies existing circuits and pastes the copied circuit to a specified location. The components are automatically retagged based on their new line reference locations.
	Move Circuit AEMOVECIRCUIT	Moves the selected circuit to a specified location. The components are automatically retagged based on their new line reference locations and cross-references are updated.
	Save Circuit to Icon Menu AESAVECIRCUIT	Saves windowed portions of circuitry for later reuse. Up to 24 circuits can be saved at any one time in this scratch menu.
	Scoot AESCOOT	Scoots selected components along their connected wires or scoots entire wires, including components, along the bus. A rectangle indicates the selected items.
	Align AEALIGN	Aligns selected components with a master component. All connected wires are adjusted, and wire numbers recentered if necessary. You can align vertically or horizontally by flipping







Command	Description
	<p>the command by typing V or H at the command line.</p>
	<p>Automatically moves the selected component to a new position.</p> <p>Reverses or flips selected component graphics and its associated attributes</p> <hr/> <p><b>NOTE</b> This tool only operates on a component with 2-wire connections (ex: limit switch contact symbol).</p>
	<p>Stretch PLC Module AESTRETCHPLC</p> <p>Stretches or compresses the windowed portion of PLC modules (or any block insert) while maintaining all of the original block information, including attributes.</p>
	<p>Split PLC Module AESPLITPLC</p> <p>Splits selected PLC module into two separate block definitions (i.e. parent and a child or a child and another child).</p>
	<p>Retag Components AERETAG</p> <p>Retags components with contact updates. Run this when something changes on your drawing or project that affects the component tags. This can include revising the ladder line reference numbers or changing the tag format. Retag redoes each selected primary component tag, and then updates the related secondary components. You can select to update a single component, a group of components, a drawing, drawings within your project, or the entire project.</p>
	<p>Find/Edit/Replace Component Text AEFINDCOMPTEXT</p> <p>Finds and replaces component and terminal text values or find and replace substrings within those values. You can do this on the active drawing or across the project drawing set.</p>







	<b>Command</b>	<b>Description</b>
	Find/Replace Terminal Text AEFINDTERMTEXT	Finds and replaces terminal number text values or find and replace sub-strings within those values. You can do this on a selection from the active drawing, the entire active drawing, or across the project drawing set.
	Move/Show Attribute AEATTSHOW	Moves the selected attributes to a picked point. The attributes remain tied to the block inserts
	Edit Selected Attribute AEEDITATT	Edits an attribute's text by picking right on the attribute. A dialog box displays and you type in a new attribute value. This utility also works on invisible attributes. It finds and displays the closest attribute to your pick point on a block insert.
	Hide Attribute (Single Picks) AEHIDEATT	Hides selected attribute; to unhide pick on block graphics and un-toggle attribute name in the list. Select the graphic of a target block insert to display a listing of all attribute names and values. You can switch attributes between hidden and visible or you can edit individual attribute values.
	Hide Attributes (Window/Multiple) AEHIDEATTRIB	Hides window selected attributes you specify in a list of names.
	Unhide Attributes (Window/Multiple) AESHOWATTRIB	Unhides window selected attributes you specify in a list of names.
	Add Attribute AEATTRIBUTE	Adds a new attribute to an existing instance of a block insert.







	Command	Description
	Rename Attribute AERENAMEATTRIB	Adds a new attribute to an existing instance of a block insert.
	Squeeze Attribute/Text AEATTSQUEEZE	Compresses an attribute to make it fit into a tight spot (such as between closely spaced components). Each click on the attribute dynamically changes the attribute's width factor by 5%.
	Stretch Attribute/Text AEATTSTRETCH	Expands an attribute. Each click on the attribute dynamically changes the attribute's width factor by 5%.
	Change Attribute Size AEATTSIZE	Changes attribute text size when components or wire numbers have already been inserted onto your drawings.
	Rotate Attribute AEATTROTATE	Rotates the selected attribute text or MTEXT string 90 degrees from its current orientation. After rotation, press M and [space] to flip into the Move Attribute mode.
	Change Attribute Justification AEATTJUSTIFY	Changes the justification of wire number text, component description text, or attributes.
	Change Attribute Layer AEATTLAYER	Forces attribute text entities to a given layer. Select the target layer (type it in or select from the list), press OK and then select the attributes to change to the target layer.
	Toggle NO/NC AETOGGLENONC	Flips a contact from one state (open or closed) to the other. It looks at the picked contact, reads its block name, and checks the 5th character position for either 1 or 2. It then substitutes 1 or 2 for the found character.



Command	Description
	<p><b>Swap/Update Block</b> AESWAPBLOCK</p> <p>Use to update or change blocks in place. Attribute values are retained during the swapping process. Wire connections are also maintained even if the new symbol is slightly wider or narrower than the original.</p>
	<p><b>Reverse Connector</b> AEREVERSE</p> <p>Reverses the orientation of the connector about its horizontal or vertical axis. None of the existing wire connections automatically reroute to the reverse side of the connector and you will have to resolve wiring using the wire editing tools.</p>
	<p><b>Rotate Connector</b> AEROTATE</p> <p>Rotates the connector about its insertion point in 90 degree increments. The wire connections do not reroute with each rotation of the connector. You must resolve wiring using the wire editing tools.</p>
	<p><b>Stretch Connector</b> AESTRETCH</p> <p>Increases or decreases the connector's overall shell length. You might do this to make room for new pins or to capture previously added pins that fell beyond the connector shell. You identify which end of the connector is to be altered and the measurement of displacement.</p>
	<p><b>Split Connector</b> AESPLIT</p> <p>Splits the parametric connector into two separate block definitions (i.e. parent and a child or a child and another child).</p>
	<p><b>Add Connector Pins</b> AECONNECTORPIN</p> <p>Adds pins to an existing connector.</p>
	<p><b>Delete Connector Pins</b> AEERASEPIN</p> <p>Removes a pin from an existing connector and, if the connector has a defined pin list, frees this deleted pin to be re-inserted later on this connector or on a related child of this connector.</p>







Command	Description
	<p>Move Connector Pin AEMOVEPIN</p> <p>Moves connector pin associated to selected connector.</p>
	<p>Swap Connector Pins AESWAPPINS</p> <p>Exchanges one set of connector pin numbers for another on an existing connector or between connectors on the drawing.</p> <p><b>NOTE</b> You cannot swap a combination connector with a single plug or receptacle connector. Additionally, you cannot use this tool to swap pins from one side of a connector to the other.</p>
	<p>Component Cross-Reference AEXREF</p> <p>Collects and annotates groups of components that carry the same TAG text string value (such as "101CR"). Components do not have to be of the same family to be cross-referenced; they just need to have the same TAG1/TAG2/TAG_*/TAG attribute values.</p>
	<p>Hide/Unhide Cross-Reference AEHIDEXREF</p> <p>Changes the visibility of cross-references. In most cases the cross-referencing should be visible but there are times when you may not want the cross-referencing displayed on parent symbols.</p>
	<p>Update Stand-Alone Cross-Reference AEUPDATESAXREF</p> <p>Updates cross-reference information for two types of cross-reference symbols: wire number signal arrow symbols and standalone cross-reference symbols. It can update your source or destination signals singly, drawing-wide, or project-wide.</p>
	<p>Change Cross-Reference to Multiple Line Text AEXREF2TEXT</p> <p>Converts a long string of relay coil or source/destination cross-reference text to a multiline text entity (MTEXT). The underlying attribute value is maintained, but flipped to visible. The MTEXT entity is created at the same XY location as the underlying attribute. The MTEXT entity updates, scoots, and be-</p>







Command	Description
	has as if it is an attribute tied to the component block.
 <p data-bbox="565 478 792 533">Cross-Reference Check AEXREFCHECK</p>	<p data-bbox="824 478 1252 743">Displays all associated and parent components to the selected component. A complete list of components is extracted from the project drawing set. The component's tag is read, then all associated components are found and listed in the dialog box. A bill of material check can be performed to see if the item's description indicates that the quantity of contacts can be accommodated.</p>
 <p data-bbox="565 783 792 867">Child Location/Description Update AECHILDLOCUPDATE</p>	<p data-bbox="824 783 1240 898">Updates child and panel components with installation, location, and description values carried by the associated parent schematic component.</p>
 <p data-bbox="565 934 792 1018">Copy/Add Component Override AECOPYOVERRIDE</p>	<p data-bbox="824 934 1252 1199">Copies and/or adds cross-reference component overrides from another symbol. You can define components to have different cross-referencing styles. The settings specified using this tool override the drawing properties. Component overrides are copied when the component is copied; similarly they are applied to multiple inserts of the same component.</p>
 <p data-bbox="565 1241 792 1325">Remove Component Override AERMOVERRIDE</p>	<p data-bbox="824 1241 1252 1325">Removes the component overrides so the cross-referencing commands use the settings for the drawing or project.</p>
 <p data-bbox="565 1379 792 1434">Cross-Reference Table AESHOWXREFTABLE</p>	<p data-bbox="824 1379 1240 1463">Displays a cross-reference table for all stand-alone PLC I/O points that carry the selected component tag.</p>
 <p data-bbox="565 1518 792 1572">Copy Installation/Location Code Values</p>	<p data-bbox="824 1518 1252 1602">Performs mass copies of location, installation, group, or mount codes to all of the components you select. You either type in the desired</p>







Command	Description
AECOPYINSTLOC	code, pick from an on-line list, or pick a similar master component.
	<b>Associate Terminals</b> <b>AEASSOCTERMINAL</b> Associates two or more terminal symbols together. Associating schematic terminals combines the terminals into a single terminal block property definition. The number of schematic terminals that can be combined is limited to the number of levels defined for the block properties.
	<b>Break Apart Terminal Associations</b> <b>AEBREAKASSOC</b> Breaks one or more terminal symbols out of an existing association. Schematic terminals are removed from any multi-tier relationship and any schematic-panel relationships. Panel terminals are removed from any schematic-panel relationships.
	<b>Show Terminal Associations</b> <b>AESHOWTERMASSOC</b> Displays terminals associated to a selected terminal.
	<b>Edit Jumper</b> <b>AEJUMPER</b> Edits the jumper information, such as adding catalog data, or deletes the jumper.
	<b>Copy Terminal Block Properties</b> <b>AECOPYTERMINALPROP</b> Copies terminal properties from one terminal symbol to another. If the application of the terminal properties reduces the number of levels and the number of terminal symbols exceeds the total allowed, an alert displays and the properties are not copied.
	<b>Terminal: Show Internal/External Connections</b> <b>AESHOWTERMCONN</b> Shows internal and external terminal block connections.







	Command	Description
	Terminal:Mark Internal Connections AEMARKTERMINT	Marks internal terminal block connections. Controls which side of a terminal receives internal wire connections.
	Terminal:Mark External Connections AEMARKTEMEXT	Marks external terminal block connections. Controls which side of a terminal receives external wire connections.
	Terminal:Erase Internal/External Connections AEERASETEMCONN	Erases internal and external terminal block connections.

## Insert Wires/Wire Numbers panel

	Command	Description
	Insert Wire AEWIRE	Inserts single line wire segments on a wire layer (the wire layer does not have to be the current layer).
	Insert 22.5 Degree Wire AE225WIRE	Inserts an angled (22.5 degree) line wire segment on a wire layer (the wire layer does not have to be the current layer).
	Insert 45 Degree Wire AE45WIRE	Inserts an angled (45 degree) line wire segments on a wire layer (the wire layer does not have to be the current layer).
	Insert 67.5 Degree Wire AE675WIRE	Inserts an angled (67.5 degree) line wire segments on a wire layer (the wire layer does not have to be the current layer).
	Interconnect Components AECONNECTCOMP	Inserts wires between aligned connection points on a pair of selected components.





Command	Description
	<p><b>Insert Wire Gap</b> AEWIREGAP</p> <p>Inserts a gap/loop at the point of two crossing lines. Gaps are automatically inserted when a new wire crosses another.</p>
	<p><b>Multiple Wire Bus</b> AEMULTIBUS</p> <p>Inserts vertical or horizontal bus wiring. Bus spacing defaults to the default ladder rung spacing for horizontal bus. Multiple bus wiring automatically breaks and reconnects to any underlying components that it finds in its path. If it crosses any existing wiring, wire-crossing gaps automatically insert (if the drawing is so configured).</p>
	<p><b>Insert Wire Numbers</b> AEWIRENO</p> <p>Inserts or updates wire numbers associated with wire line entities.</p>
	<p><b>3 Phase Wire Numbers</b> AE3PHASEWIRENO</p> <p>Inserts special wire numbering generally associated with 3-phase bus and motor circuits.</p>
	<p><b>PLC I/O Wire Numbers</b> AEPLCWIRENO</p> <p>Inserts wire numbers based on the I/O address that each PLC connected wire touches. Wire numbers go in as FIXED which means that they will not change if a wire number retag is run later on.</p>
	<p><b>Source Signal Arrow</b> AESOURCE</p> <p>Copies wire number from a source-arrowed wire network to any/all associated destination-arrowed wire network.</p>
	<p><b>Destination Signal Arrow</b> AEDESTINATION</p> <p>Retrieves the wire number for a destination-arrowed wire network from its associated source-arrowed wire network.</p> <p><b>NOTE</b> A Destination signal arrow cannot be tied to a wire network that carries a pre-assigned fixed wire number.</p>

	Command	Description
	Fan In/Out Source AEFANINSRC	Inserts in-line source marker symbols and changes the connected wire on the fan-in side to be on a non-wire layer.
	Fan In/Out Destination AEFANINDEST	Changes the connected common wires on the fan-out side to non-wire layer but leaves the individual segments on the opposite side of marker on the original wire layer.
	Wire Arrows for Reference Only AEREFWIREARROWS	Inserts non intelligent, reference-only arrows.
	Insert Ladder AELADDER	Inserts ladders of a set width and length onto the drawing. There is no limit to the number of ladders that can be inserted into a drawing, but ladders may not overlap each other. Multiple ladder fragments in the same vertical column need to be vertically aligned along their left-hand side.  <b>NOTE</b> These limitations do not apply when X-Y Grid or X-Zone referencing is selected.
	XY Grid Setup AEXYGRID	Inserts the X-Y grid labels for drawings that use X-Y Grid for the Format Referencing. You can also change other settings from here (such as origin) instead of going back into the Drawing Properties dialog box. Your drawing must be configured for X-Y Grids. Set the Format Referencing in the Drawing Properties dialog box to X-Y Grid.
	X Zones Setup AEXZONE	Inserts the X grid labels for drawings that use X Zones for the Format Referencing. You can also change other settings from here (such as origin) instead of going back into the Drawing Properties dialog box. Your drawing must be configured for X Zones. Set the Format Refer-









Command	Description
	<p>Wire Number Leader AEWIRENOLEADER</p> <p>Repositions the wire number text with an attached leader.</p>
	<p>Wire Color/Gauge Labels AEWIRECOLORLABEL</p> <p>Inserts wire color gauge labels with a leader on your drawing's wiring.</p>
	<p>In-Line Wire Labels AEINLINEWIRE</p> <p>Inserts a reference-only in-line wire label.</p>
	<p>Cable Markers AECABLEMARKER</p> <p>Inserts cable markers onto the drawing. Cable markers carry a cable TAG value, just like any parent/child device combination. They can also carry a conductor color value (carried as a RATING1 attribute value on the marker block symbol).</p>
	<p>Multiple Cable Markers AEMULTICABLE</p> <p>Inserts all the markers for a particular cable. In addition, you can edit existing cable marker sets, or even delete cable markers from this dialog box.</p>
	<p>Insert Dot Tee Markers AEDOTTEE</p> <p>Inserts a dot tee connection symbol at a manually drawn wire intersection. If present, this replaces an existing angled wire connection symbol with a dot connection symbol. You cannot insert a tee connection symbol into empty space. A valid line wire ending (not crossing) at a tee intersection somewhere along the length of another line wire is needed. This means that it will not insert a tee connection symbol at a 90-degree wire turn.</p>





	Command	Description
	Insert Angled Tee Markers AEANGLETEE	Inserts an angled tee connection symbol at a manually drawn wire intersection. You cannot insert a tee connection symbol into empty space. If present, this replaces an existing wire connection dot with a tee connection symbol.





## Edit Wires/Wire Numbers panel







	Command	Description
	Edit Wire Number AEEDITWIRENO	Allows manual edit of an existing wire number or insert of a new one if none exists.
	Fix Wire Numbers AEFIXWIRENO	Fixes all or many wire numbers on a drawing at their current values. Fixing a wire number means that the wire number tag is left unchanged if later processed or reprocessed by the automatic wire numbering utility.
	Swap Wire Numbers AESWAPWIRENO	Swaps wire numbers between two wire networks.
	Find/Replace Wire Numbers AEFINDWIRENO	Finds and replaces wire number text values or substrings within those values. You can do this on the active drawing or across the project drawing set.
	Hide Wire Numbers AEHIDEWIRENO	Moves the wire number to a special hide layer so that the number is no longer visible on the screen. The new hide layer is created from the wire number layer name with a “_HIDE” suffix. For example, if the wire number text layer is called WIRENO then the hide layer name is called “WIRENO_HIDE.” The layer is created automatically when needed and you are asked if you want to freeze this layer.







Command	Description
	<p>Unhide Wire Numbers AESHOWWIRENO</p> <p>Moves the wire number out of the hide layer so that the number is visible on the screen.</p>
	<p>Trim Wire AETRIM</p> <p>Removes a wire segment and dots as required. You can select a single wire or draw a fence through multiple wires to trim.</p>
	<p>Delete Wire Numbers AEERASEWIRENUM</p> <p>Deletes selected wire numbers.</p> <p><b>NOTE</b> If you erase a wire number and select right on an extra wire number copy, AutoCAD Electrical erases just that copy but leaves the network's main wire number and any other copies in place.</p>
	<p>Add Rung AERUNG</p> <p>Finds the nearest line reference location and places a ladder rung at that reference position (both bus wires must be visible on the screen for this to work. If the new rung encounters a schematic device floating in space, it tries to break the wire across the device.</p>
	<p>Revise Ladder AEREVISELADDER</p> <p>Adjusts the line reference numbering along the side of the ladders; however it doesn't change existing ladder rung spacing.</p>
	<p>Renumber Ladder Reference AERENUMBERLADDER</p> <p>Renumbers the ladder for the selected drawings from the active project.</p>
	<p>Create/Edit Wire Type AEWIRETYPE</p> <p>Creates and edits wire types. Use the grid control to sort and select the wire types for easy modification.</p>
	<p>Change/Convert Wire Type AECONVERTWIRETYPE</p> <p>Changes between wire types and converts lines to wires. Use the grid control to sort and select the wire types for easy modification.</p>



Command	Description
 <p data-bbox="570 396 756 449">Copy Wire Number AECOPYWIRENO</p>	<p data-bbox="829 396 1252 722">Inserts extra wire numbers anywhere on a wire network. These copies follow the network's main wire number attribute. If AutoCAD Electrical modifies it, then any wire number copies on the network also update. Extra wire numbers go on their own layer that is defined in the Define Layers dialog box. If you assign a color to this layer that is different than the normal wire number and fixed wire number layers, then it is easy to tell them apart from the network's main wire number.</p>
 <p data-bbox="570 764 794 848">Copy Wire Number (In-Line) AECOPYWIRENOIL</p>	<p data-bbox="829 764 1252 1121">Inserts extra wire numbers such that they appear in-line with the wire rather than above or below the wire. These copies follow the network's main wire number attribute; if AutoCAD Electrical modifies it then any wire number copies on the network also update. Extra wire numbers go on their own layer that is defined in the Define Layers dialog box. If you assign a color to this layer that is different than the normal wire number and fixed wire number layers, then it is easy to tell them apart from the network's main wire number.</p>
 <p data-bbox="570 1163 797 1247">Adjust In-Line Wire/Label Gap AEWIRELABELGAP</p>	<p data-bbox="829 1163 1252 1247">Adjusts the gap between the wire and the wire number text of wire numbers that are in-line with the wire.</p>
 <p data-bbox="570 1299 756 1352">Move Wire Number AEMOVEWIRENO</p>	<p data-bbox="829 1299 1252 1352">Moves an existing wire number from one segment of the network to another.</p>
 <p data-bbox="570 1436 727 1499">Stretch Wire AESTRETCTWIRE</p>	<p data-bbox="829 1436 1252 1499">Lengthens a wire until it meets another wire or an AutoCAD Electrical component.</p>







Command	Description
 <p data-bbox="615 396 748 449">Bend Wire AEBENDWIRE</p>	<p data-bbox="873 396 1300 569">Bends a wire in a right angle and makes 3 right angle turns to avoid or add geometry. When a wire is defined at a right angle you can modify the wire and create a new right angle bend while maintaining the original wire connections to the components.</p> <hr/> <p data-bbox="873 594 1300 709"><b>NOTE</b> This tool terminates if the bend attempts to connect two different wire networks or if the bend bypasses more than a single right angle turn.</p>
 <p data-bbox="615 747 748 800">Show Wires AESHOWWIRE</p>	<p data-bbox="873 747 1300 800">Highlights all wires and displays wire number to wire segment relationships.</p>
 <p data-bbox="615 894 748 947">Check/Trace Wire AETRACEWIRE</p>	<p data-bbox="873 894 1300 1041">Helps troubleshoot problems with unconnected or shorted wires and invalid wire crossing gap pointers by single stepping through and highlighting each connected wire of the selected wire network.</p>
 <p data-bbox="615 1083 748 1136">Flip Wire Number AEFLIPWIRENO</p>	<p data-bbox="873 1083 1300 1136">Flips the wire number across its associated wire.</p>
 <p data-bbox="615 1220 748 1293">Toggle Wire Number In-line AETOGGLEWIRENO</p>	<p data-bbox="873 1220 1300 1419">Switches the wire number between above or below and in-line. If the selected wire number is in-line, it toggles to above or below based on the default Wire Number Placement setting in the Drawing Properties dialog box. If it starts as above or below, the selected wire number toggles to in-line.</p> <hr/> <p data-bbox="873 1444 1300 1524"><b>NOTE</b> If there isn't room for a wire number to become an in-line wire number, it remains an above or below line wire number.</p>



	Command	Description
	Toggle Angled Tee Markers AETOGGLETEE	Toggles an existing angled tee connection symbol (or windowed symbols) through a total of 4 possible orientations. Right-click to toggle through the various tee connection orientations, and press ESC when the appropriate one displays. This replaces any dot tee symbols with angled tee symbols, and then toggles through the 4 possible orientations for each.
	Flip Wire Gap AEFLIPWIREGAP	Flips the gap to the other wire. AutoCAD Electrical makes the gapped wire solid and flips the gap/loop to the crossing wire(s).
	Delete Wire Gap AEERASEWIREGAP	Removes a gap/loop that is no longer needed in an existing wire.
	Check/Repair Gap Pointers AEGAPPOINTER	Verifies that the invisible Xdata pointers on both sides of a wire gap/loop are valid. If not, appropriate pointers are established.
	Edit Wire Sequence AEEDITWIRESEQUENCE	Predefines a wire network's connection sequence, either in a single drawing or across multiple drawing files.
	Show Wire Sequence AESHOWWIRESEQ	Shows the wire sequence defined using the Define Wire Sequence tool. If the wire sequence crosses multiple drawings and you try to view the sequence as an animation, a dialog box listing the off-drawing wire connection information displays so that you can indicate to go to the other drawings to continue viewing the sequence.
	Update Signal References AEUPDATESIGREF	Updates cross-reference information for two types of cross-reference symbols. Wire number signal arrow symbols and standalone cross-reference symbols.

	Command	Description
	Fan In/Out - Single Line Layer AEFANIN	Defines a special layer or set of layers for the wires going out of a Fan In/Out source marker and the wires coming into a destination marker.
	List Signal Code AELISTSIG	Follows a signal from a specific source or destination symbol and lists the signal code references.
	Show Signal Paths AESHOWSIG	Displays signal source and destination paths on the active drawing.
	Multiple Cable Markers Update AEUPDATECABLEMARKERS	Updates cable marker assignments defined or edited in a from/to listing.

## Other Tools panel



	Command	Description
	Symbol Builder AESYMBUILDER	Converts existing symbols or creates new, custom components on the fly. It works nicely for quickly building power supplies, filters, drives, controllers, and other custom devices or for converting existing non-AutoCAD Electrical symbols to make them "AutoCAD Electrical smart." Schematic symbols created or converted using the Symbol Builder are fully compatible with AutoCAD Electrical, break wires upon insertion, and appear in the various BOM, component, and wire connection reports.
	Modify Symbol Library AEUPDATESYMLIB	Performs an update of all library symbol scaling and text heights in the folder.

	Command	Description
	Icon Menu Wizard AEMENUWIZ	Launches the Icon Menu Wizard to easily modify or expand an icon menu, or replace an existing icon menu with your own custom menu. You can change the default icon menu using the Project Properties dialog box. The default icon menu can also be redefined in "wd.env."
	Drawing Properties AEPROPERTIES	Defines defaults for component and wire tag formats, signal references, cross references, and layers.
	Rename Schematic Layers AERENAMELAYER	Renames layers one by one, or multiple layers at once by using the Find/Replace method. In addition to renaming the layer, this also updates the AutoCAD Electrical layer assignment information carried on the drawing's WD_M block. For example, if DEMO-WIRES is currently assigned as an AutoCAD Electrical wire layer, and you rename it using this utility, the new layer name is substituted for DEMO-WIRES in the AutoCAD Electrical wire layer name list.
	Settings Compare AESHEETCOMPARE	Displays differences between drawing and project settings. Allows update.
	PLC Database File Editor AEPLCDB	Creates and modifies PLC I/O module definitions. All editing and creation of PLC data is stored within the PLC database file (ACE_PLC.MDB).
	Electrical Standards Database Editor AEBDEDITOR	Edits the electrical standards database file, ace_electrical_standards.mdb. The electrical standards database file sets default Circuit Builder values, defines calculations, and allows Circuit Builder to perform engineering analysis in the area of power conductor size versus energy losses

	Command	Description
	Pin List Database Editor (AEPINLISTTABLE)	Edits a pin list database table in the catalog database.
	Terminal Properties Database Editor AETERMDBEDITOR	Edits a Terminal Properties table in the catalog database.
	Schematic Database File Editor AESCHEMATICDB	Edits the records in the schematic_lookup.mdb file to use for mapping panel footprints and terminal representations to the equivalent schematic component block names.

## Power Check Tools panel



The Power Check Tools panel is off by default.

	Command	Description
	Add/Edit Power Source/Load Levels AEPOWERLOADLEVELS	Marks a component with a power source and load value. A related routine, when invoked, then scans the wire interconnections and reports if there is too much load on a given power source
	Mark Component To Pass Power AEPASSPWR	Marks a component with a PASSPWR flag. The PASSPWR flag instructs the Power Report to pass through the marked component when calculating the load on a given source. If a component carries the PASSPWR flag the Power Report program will pass through the component and continue looking for load values on the network.
		<b>NOTE</b> Certain components don't need a PASSPWR flag (such as terminals and contacts) since they are automatically passed through.







	Command	Description
	Power Load Check Report AEPOWERLOADREPORT	Scans the wire interconnections and reports if there is too much load on a given power source.

## Panel tab

### Insert Component Footprints panel





	Command	Description
	Insert Footprint (Icon Menu) AEFOOTPRINT	Inserts panel footprint selected from on-screen icon menu. This icon menu can be modified, expanded, or replaced with your own custom menu. You can change the default icon menu using the Project Properties dialog box. Use the Icon Menu Wizard to easily modify the menu.
	Insert Footprint (Schematic List) AEFOOTPRINTSCH	Inserts and annotates panel footprint by referencing the project's schematic component list. This report provides error checking between the schematics and the panel layout drawings. The program looks at the selected components, both schematic and panel, to find a match in the project. For each schematic component selected, the routine tries to find a matching panel component based on tag, location, and installation information. If a match is found, then it further compares catalog information looking for any discrepancies. The program looks at each selected panel component looking for a matching schematic component in the same way.
	Insert Footprint (Manual) AEFOOTPRINTMAN	Inserts panel footprint using a generic shape or by converting an existing non intelligent AutoCAD block.



Command	Description
	<p>Insert Footprint (Manufacturer Menu) AEFOOTPRINTMFG</p> <p>Inserts and annotates panel footprint using manufacturer-specific icon menu. This can save a lot of time if you frequently use the same vendor and panel components. You can even apply this method to create client-specific menus making it easier to use the vendor or components that each client prefers.</p>
	<p>Insert Footprint (Catalog List) AEFOOTPRINTCAT</p> <p>Inserts and annotates panel footprint from user-defined list of components with catalog assignments. The data displayed in this pick list is stored in a database in generic Microsoft Access format. The file name is wd_pick-list.mdb and can be edited with Access or from Add/Edit/Delete along the bottom of the pick list's dialog box. The AutoCAD Electrical normal search path sequence is used to locate this file.</p>
	<p>Insert Footprint (Equipment List) AEFOOTPRINTEQ</p> <p>Inserts and annotates panel footprint from user-defined list of equipment.</p>
	<p>Insert Balloon AEBALLOON</p> <p>Inserts item number balloon.</p>
	<p>Wire Annotation of Panel Footprint AEWIREANNOTATION</p> <p>Annotates panel footprint symbols with wire connection information extracted from selected schematics.</p>
	<p>Insert Panel Assembly AEPANELASM</p> <p>Inserts WBlocked panel footprint assembly. Use the Insert Panel Assembly utility instead of the AutoCAD Insert/Explode command when you want to insert a WBlocked group of panel component footprints with balloons or nameplates. Since AutoCAD Electrical establishes invisible Xdata pointers when these are</p>



Command	Description
	<p>When terminal strips are placed in a drawing and are tied to a footprint, they are properly updated when copied using this utility.</p>







## Terminal Footprints panel

Command	Description
 <p>Terminal Strip Editor AETSE</p>	<p>Displays terminal strips inside of the active project database. The combination of Function, Location, and Terminal Strip values make a complete unique record for selection in the Terminal Strip Selection dialog box.</p>
 <p>Terminal Strip Table Generator AETSEGENERATOR</p>	<p>Controls the Tabular Terminal layout format automatically. This creates a new drawing file with each section break and automatically adds them to the project listing. The terminal strip's function (installation) code, location code, and tag are written to the Page Description Field inside of the Project Listing (*.WDP).</p>
 <p>Insert Terminal (Schematic List) AEPANELTERMINALSCH</p>	<p>Inserts and annotates panel terminals by referencing the project's schematic terminal list. This report provides error checking between the schematic terminals and panel layout terminals. The program looks at the selected terminals, both schematic and panel, looking for a match in the project. For each schematic terminal selected, it tries to find a matching panel terminal based on tag, location, and installation information. If a match is found, then it compares catalog information, and description information, looking for any discrepancies. The program then looks at each selected panel terminal looking for a matching schematic terminal in the same way.</p>
 <p>Insert Terminal (Manual) AEPANELTERMINAL</p>	<p>Inserts and annotates panel terminal footprint using a generic shape or by converting an existing non intelligent AutoCAD block. Some</p>





Command	Description
	schematic components may not carry manufacturer/catalog information or have a part number assigned that is not listed in the footprint lookup file. In such a case, AutoCAD Electrical cannot determine what footprint block needs to be used so you have to select to make catalog assignments, select or create a footprint, or create a lookup entry on the fly.



## Edit Footprints panel

Command	Description
 Edit Footprint AEEDITFOOTPRINT	Edits panel footprint or terminal. Converts selected block if it is not AutoCAD Electrical compatible. In some cases, a footprint update may be required due to manufacturer, catalog or assembly value changes. When asked whether to manually force a footprint change, click No to leave the existing footprint block as is or click Yes to set up a footprint lookup database file or manually draw a simple footprint representation.
 Copy Footprint AECOPYFOOTPRINT	Copies selected panel footprint on active drawing. Use the Copy Footprint tool instead of AutoCAD Copy when a panel component footprint has a balloon or a nameplate associated to it. Since AutoCAD Electrical establishes invisible Xdata pointers when these are tied to a footprint, they are properly updated when copied using this utility.
 Resequence Item Numbers AERESEQUENCE	Assigns or resequences item number assignments on a drawing or project. This extracts all panel components and nameplates and resequences their item numbers starting at the value you provide. Resequencing is based on the main MFG/CAT/ASSYCODE value

Command	Description
	combination. Additional multi-catalog numbers on a specific component are ignored. Only the main part number combination is used to group similar components together under a common item number.
 Delete Footprint AERASECOMP	Removes the selected footprint from the drawing. You have the option to search for related components, surf to them, and delete them.
 Copy Installation Code AECOPYINST	Copies Installation Code to one or more selected panel footprints.
 Copy Location Code AECOPYLOC	Copies Location Code to one or more selected panel footprints.
 Copy Mount Code AECOPYMOUNTCODE	Copies Mount Code to one or more selected panel footprints.
 Copy Group Code AECOPYGROUPCODE	Copies Group Code to one or more selected panel footprints.
 Copy Assembly AECOPYASM	Copies one or more selected panel footprints.



## Other Tools panel





	Command	Description
	Symbol Builder AESYMBUILDER	Converts existing symbols or creates new, custom components on the fly. It works nicely for quickly building power supplies, filters, drives, controllers, and other custom devices or for converting existing non-AutoCAD Electrical symbols to make them "AutoCAD Electrical smart." Schematic symbols created or converted using the Symbol Builder are fully compatible with AutoCAD Electrical, break wires upon insertion, and appear in the various BOM, component, and wire connection reports.
	Icon Menu Wizard AEMENUWIZ	Launches the Icon Menu Wizard to easily modify or expand an icon menu, or replace an existing icon menu with your own custom menu. You can change the default icon menu using the Project Properties dialog box. The default icon menu can also be redefined in "wd.env."
	Panel Configuration AEPANELCONFIG	Sets panel footprint drawing defaults such as text sizes and layer assignments. Configuration settings are saved as attribute values on a non-visible block named WD_PNLN (that inserts at 0,0). If your current drawing does not have this block present when any AutoCAD Electrical panel layout command is invoked, AutoCAD Electrical pauses and asks you for permission to insert this block.
	Rename Panel Layers AERENAMEPANLELLAYER	Renames panel-related layers and updates panel drawing settings. The Panel Layer Rename utility makes it easy to rename layers one by one, or multiple layers at once by using the Find/Replace method. In addition to renaming the layer, this also updates the AutoCAD Electrical layer assignment information carried on the drawing's WD_M block. For

Command	Description
	example, if DEMO-WIRES is currently assigned as an AutoCAD Electrical wire layer, and you rename it using this utility, the new layer name is substituted for DEMO-WIRES in the AutoCAD Electrical wire layer name list.
 Update Footprint Layers AEFPLAYERS	Updates selected footprint layer assignments to match panel drawing settings layer assignments.
 Make Xdata Visible AESHOWXDATA	Converts any piece of non-visible extended entity data (Xdata) into a visible attribute tied directly to the footprint block.
 Footprint Database File Editor AEFOOTPRINTDB	Edits the catalog number and footprint block name lookup file. The footprint lookup database links a manufacturer's catalog part numbers to appropriate footprint block <i>.dwg</i> files. This information is in a multitable Access database file ( <i>footprint_lookup.mdb</i> ).

## Conduit Tools panel

The Conduit Tools Panel is off by default.





Command	Description
 Conduit Marker (Pick) AECONDUITMARKER	Formats an inter-wiring list from a selection of interconnected components. Inserts as a conduit tag.
 Conduit Marker (From/To List) AECONDUITMARKERLIST	Formats an inter-wiring list from a subset of a component from/to report. Inserts as a conduit tag.

	Command	Description
	Edit Conduit Marker AEEDITCONDUITMARKER	Edits conduit marker tag, descriptions, and wire assignments.
	Conduit Marker Report AECONDUITMARKERRPT	Extracts conduit marker information into a report. Extractable conduit marker symbols are named "WVAY*." A conduit can be represented by a line or a polyline and by itself does not carry any intelligence. However, you can insert a conduit marker symbol and associate it to a conduit. The conduit marker symbol then carries wire information intelligence pulled from the AutoCAD Electrical drawings.
	Wire/Conduit Routing Report AEROUTINGREPORT	Reports a list of conduit tag assignments that a given wire or cable passes through.
	Extract Wire Data AEEXTRACTWIREDATA	Extracts schematic wiring information prior to conduit assignment.

## Reports tab

### Schematic panel

	Command	Description
	Schematic Reports AESCHEMATICREPORT	Generates schematic reports such as Bill of Material, Component lists, Wire From/To, PLC descriptions.

	Command	Description
	Show Missing Catalog Assignment AEMISSINGCATREPORT	Displays components that do not carry a catalog number assignment. The components are marked with diamond-shaped temporary graphics.
	Electrical Audit AEAUDIT	Displays a report of detected problems or potential problems. You can save this file for reference or surf the file to view and correct the errors.
	Drawing Audit AEAUDITDWG	Displays a report of detected problems or potential problems. You can save this file for reference or surf the file to view and correct the errors.
	Signal Error/List Report AESIGNALERRORREPORT	Displays a signal list and exception report.



## Panel panel

	Command	Description
	Panel Reports AEPANELREPORT	Generates panel reports such as Bill of Material, Component lists, Nameplates.

## Miscellaneous panel



	Command	Description
	Automatic Report Selection AEAUTOREPORT	Defines a list of reports and their format files to run automatically.







	Command	Description
	Report Format File Setup AEFORMATFILE	Creates and maintains report formatting files.
	User Defined Attribute List AEUDA	Creates an attribute text file (*.wda) of user-defined attributes defined on AutoCAD Electrical block files. The User Defined Attribute List is used by report tools to determine which additional attributes are listed in a report. The list file name can be the same as the active project or named Default to be used by the entire system. The Default .wda file is saved in the base project folder, while the <project_name>.wda file is saved in the same folder as the project definition file (*.wdp).



## Import/Export Data tab

### Import panel

	Command	Description
	Unity Pro Export to Spreadsheet AEUNITYPROSS	Imports Unity Pro hardware (.xhw) and I/O variable (.xsy) files into AutoCAD Electrical to reformat the data into a PLC import spreadsheet. After the spreadsheet file is created use the Spreadsheet to PLC I/O Utility tool to automatically create PLC style drawing files.
	Spreadsheet to PLC I/O Utility AEISS2PLC	Creates a set of PLC I/O drawings from spreadsheet data. A project's PLC I/O requirements, in spreadsheet or database format, can drive automatic generation of the I/O schematic drawings. Your information can be read directly in Excel format (".XLS"), as a table in an Access Database file (.MDB), or you can save your information out to a comma-delimited format (".CSV") and then let AutoCAD

Command	Description
	Electrical construct a set of PLC I/O wiring diagrams directly from your data. Ladders and modules insert automatically, breaking at the bottom of one ladder and continuing on the next (or on to the next drawing).
 Update from Spreadsheet AEIMPORTSS	Imports data from an edited spreadsheet, and retags or updates components, wire numbers, terminal text, or PLC I/O.
 Update from Project Scratch Database AEIMPORTDB	Updates project drawings; attribute text only, from edits to the project's scratch database file.
 Insert Spreadsheet Data to Table AEINSERTSTABLE	Inserts comma-delimited spreadsheet data into a drawing as a table.
 RSLogix 500 Export to Spreadsheet AERSLOGIX	Prepares RSLogix 500 exported data to be processed by the Spreadsheet to PLC I/O Utility.





## Export panel









Command	Description
 Autodesk Inventor Professional Export AEAIPEXPORT	Extracts wire list information into an XML export file to be used exclusively with Autodesk Inventor Professional Cable and Harness.  <b>NOTE</b> You must first configure wire numbering to be <i>On per Wire Basis</i> for export and set up the appropriate variables before running the report.
 Unity Pro Export AEUNITYPRO	Creates the Unity Pro I/O variable file (.xsy) in the Unity Pro XML format. The XML file con-







Command	Description
	tains the PLC I/O addresses and descriptions for import into the Unity Pro software.
	<b>Export to Spreadsheet</b> <b>AEEXPORT2SS</b> Exports the selected data category to a comma-delimited, Excel XLS, or Access MDB file format for editing.

## Conversion Tools tab





### Tools panel





Command	Description
	<b>Promis-e Conversion</b> <b>AEP2E</b> Converts drawing files from promis-e to AutoCAD Electrical. It examines the current symbol attributes on the drawing and maps them to the equivalent AutoCAD Electrical attribute to make them AutoCAD Electrical-smart.
	<b>Add Geometry</b> <b>AEGEOMETRY</b> Adds AutoCAD geometry to a template block file to be created as part of a unique block instance. It creates a new block definition with the newly added geometry. You can subsequently create a new block file if the block is exploded.
	<b>Add Wire Connections</b> <b>AEWIRECONN</b> Adds wire connection attributes to the existing tagged block file. Select line endpoints or geometry to add the appropriate wire connection attributes to. A new block definition is created with the newly added wire connections. You can subsequently create a new block file if the block is exploded.
	<b>Special Explode</b> <b>AEEXPLODE</b> Explodes attributes and blocks to geometry and text entities while maintaining the value previously defined in the attributes. You can

	Command	Description
		take advantage of the tagging tools to modify the text entities to attributes and the linking tools to make various blocks.
	Convert Ladder AE2LADDER	Converts the upper-most line reference number on a non-intelligent ladder to be AutoCAD Electrical-aware.
	Change/Convert Wire Type AECONVERTWIRETYPE	Changes between wire types and converts lines to wires. Use the grid control to sort and select the wire types for easy modification.
	Check/Repair Gap Pointers AEGAPPOINTER	Verifies that the invisible Xdata pointers on both sides of a wire gap/loop are valid. If not, appropriate pointers are established.
	Change Attribute Size AEATTSIZE	Changes attribute text size when components or wire numbers have already been inserted onto your drawings.
	Xdata Editor AEXDATA	Allows display and edit of an object's "1000" type extended entity data (Xdata).
	Convert to Schematic Component AEBLK2SCH	Takes non-AutoCAD Electrical blocks or graphics representing a symbol and replaces it with an AutoCAD Electrical block and transfers the attribute or text values to this new AutoCAD Electrical block.
	Convert Block to Source Arrow AEBLK2SRC	Replace a non-AutoCAD Electrical source arrow with a smart AutoCAD Electrical source arrow and maps the information to the new AutoCAD Electrical source.
	Convert Block to Destination Arrow AEBLK2DEST	Replaces a non-AutoCAD Electrical destination arrow with a smart AutoCAD Electrical destination arrow.





Command	Description
	<p><b>Block Replacement</b> AEBLOCKREPLACE</p> <p>Performs drawing-wide and project-wide block replacements using a user-defined spreadsheet. This automatically maps the unconverted drawing's non-AutoCAD Electrical block inserts and attributes to appropriate AutoCAD Electrical-smart component symbols drawn from a symbol library.</p>
	<p><b>Swap/Update Block</b> AESWAPBLOCK</p> <p>Use to update or change blocks in place. Attribute values are retained during the swapping process. Wire connections are also maintained even if the new symbol is slightly wider or narrower than the original.</p>
	<p><b>Convert Text to Wire Numbers</b> AETEXT2WIRENO</p> <p>Converts a text object to an AutoCAD Electrical compatible wire number.</p>
	<p><b>Convert Text to Attribute Definition</b> AETEXT2ATT</p> <p>Converts a text object into an attribute definition object. This is not an attribute associated to an already-inserted block. This is an attribute definition possibly on a library symbol that becomes an attribute when the symbol drawing is inserted as a block into another drawing.</p>
	<p><b>Add Attribute</b> AEATTRIBUTE</p> <p>Adds a new attribute to an existing instance of a block insert.</p>
	<p><b>Map Attributes from Old to New</b> AEMAPATT</p> <p>Reassigns attributes from a converted block to those expected by AutoCAD Electrical. This allows you to continue what you started with Convert to Schematic Component. Use this if you did not finish mapping values from your non-AutoCAD Electrical block.</p>
	<p><b>Stretch Wire</b> AESTRETCTWIRE</p> <p>Lengthens a wire until it meets another wire or an AutoCAD Electrical component.</p>

## Schematic panel

	Command	Description
	Tag Schematic Component AETAGSCH	Makes selected text entities an attributed block file with the TAG1 attribute visible. The template block file (HDV1_CONVERT.DWG or VDV1_CONVERT.DWG depending on the drawing properties) contains attributes for a schematic component.
	Tag PLC AETAGPLC	Makes selected text entities an attributed PLC address associated to a PLC tag. The template block file (PLCIO_ADDR_CONVERT.DWG, PLCIO_CONVERT.DWG, PLCIO_V_ADDR_CONVERT.DWG, or PLCIO_V_CONVERT.DWG depending on the drawing properties) contains attributes found useful for PLC addressing. After the addressing is defined on the block, select a PLC Tag or place one into the symbol definition for use with AutoCAD Electrical.
	Tag Child AETAGCHILD	Makes selected text entities an attributed block file with the TAG2 attribute visible. The template block file (HDV2_CONVERT.DWG or VDV2_CONVERT.DWG depending on the drawing properties) contains attributes used for a child component.
	Tag Child - N.O. AETAGNO	Makes selected text entities an attributed block file with the TAG2 attribute visible. The template block file (HDV21_CONVERT.DWG or VDV21_CONVERT.DWG depending on the drawing properties) contains attributes used for a child normally open contact component.
	Tag Child - N.C. AETAGNC	Makes the selected text entities an attributed block file with the TAG2 attribute visible. The template block file (HDV22_CONVERT.DWG or VDV22_CONVERT.DWG depending on the drawing properties) contains attributes used for a child normally closed contact component.

Command	Description
	<p><b>Tag Child - Form C</b> AETAGFORMC</p> <p>Makes the selected text entities an attributed block file with the TAG2 attribute visible. The template block file (HDV23_CONVERT.DWG or VDV23_CONVERT.DWG depending on the drawing properties) contains attributes used for a child Form C contact component.</p>
	<p><b>Tag Schematic Terminal - Terminal Number</b> AETAGTERMINAL</p> <p>Makes the selected text entities an attributed block file with the TAGSTRIP and TERM01 attribute visible. The template block file (HT0T_CONVERT.DWG or VT0T_CONVERT.DWG depending on the drawing properties) contains attributes used for a terminal block component containing a terminal number.</p>
	<p><b>Tag Schematic Terminal - Wire Number</b> AETAGWIRENO</p> <p>Makes the selected text entities an attributed block file with the TAGSTRIP and WIRENO attribute visible. The template block file (HT0W_CONVERT.DWG or VT0W_CONVERT.DWG depending on the drawing properties) contains attributes used for a terminal block component containing a wire number as the terminal number.</p>
	<p><b>Tag Schematic Terminal - Wire Number Change</b> AETAGWIRENOCHANGE</p> <p>Makes the selected text entities an attributed block file with the TAGSTRIP and TERM01 attribute visible. The template block file (HT1T_CONVERT.DWG or VT1T_CONVERT.DWG depending on the drawing properties) contains attributes used for a terminal block component that changes the wire number. This creates a terminal number block that has a different wire number for each wire connected to it.</p>





## Panel panel





	Command	Description
	Tag Panel Component AETAGPANEL	Makes selected text entities an attributed block file with the P_TAG1 attribute visible. The template block file (ACE_P_TAG1_CONVERT.DWG) contains attributes for a panel component.
	Tag Nameplate AETAGNAMEPLATE	Makes selected text entities an attributed block file with the DESC1-3 attributes visible. The template block file (ACE_NP_CONVERT.DWG) contains attributes used in nameplate symbols. If the description text strings were previously defined as attributes on an AutoCAD Electrical panel component block definition, the attribute values on the panel component are hidden and the nameplate attributes DESC1-3 are added and made visible.
	Tag Panel Terminal - Terminal Number AETAGPANELTERMINAL	Makes selected text entities an attributed block file with the TERM01 terminal number attribute visible. The template block file (ACE_TERM_CONVERT.DWG) contains attributes for terminal numbers.
	Tag Panel Terminal - Wire Number AETAGWIRENO	Makes selected text entities an attributed block file with the WIRENO wire number attribute visible. The template block file (ACE_TERMW_CONVERT.DWG) contains attributes for panel terminal symbols.



## Attributes panel

	Command	Description
	Link Descriptions AELINKDESC	Links simple text as Description 1-3 attributes on an AutoCAD Electrical block file. You can link them as description attributes to one or more existing template block definitions. During the conversion process, the text entity

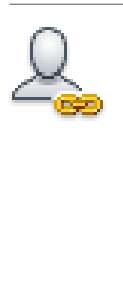

Command	Description
	<p>is removed and replaced with the next available description attribute, up to 3.</p> <p>Link PLC Address Descriptions AELINKPLC</p> <p>Links simple text to a PLC address attribute as PLC I/O address description attributes. During the conversion process, the text entity is removed and replaced with the next available PLC address description attribute, up to 5.</p>
	<p>Link Terminal Number AELINKTERMINAL</p> <p>Links simple text to a TAGSTRIP attribute as a terminal number attribute on an AutoCAD Electrical terminal block symbol. During the conversion process, the text entity is removed and replaced with the TERM01 or WIRENO attribute.</p>
	<p>Link Manufacturer AELINKMFG</p> <p>Links simple text as manufacturer attributes on an AutoCAD Electrical block file. The entity value is used as the Manufacturer value for one or more template block definitions. If only one template block is selected for the link, the text entity is removed and replaced with the Manufacturer attribute.</p>
	<p>Link Catalog Number AELINKCAT</p> <p>Links simple text as Catalog Number attributes on an AutoCAD Electrical block file. The entity value is used as the Catalog Number value for one or more template block definitions. If only one template block is selected for the link, the text entity is removed and replaced with the Catalog Number attribute.</p>
	<p>Link Location Code AELINKLOC</p> <p>Links simple text as Location attributes on an AutoCAD Electrical block file. The entity value is used as the Location value for one or more template block definitions. If only one template block is selected for the link, the text entity is removed and replaced with the Location attribute.</p>



	Command	Description
	Link Installation Code AELINKINST	Links simple text as Installation attributes on an AutoCAD Electrical block file. The entity value is used as the Installation value for one or more template block definitions. If only one template block is selected for the link, the text entity is removed and replaced with the Installation attribute.
	Link Split Tag AELINKSPLITTAG	Links another string of text to a tag attribute, creating a split tag. Create the device Tag using the TAG1, TAG, or P_TAG1 attributes, and then use this tool to select the existing TAG attribute on the drawing and link another string of text, creating a split tag situation. The first TAG becomes the Part1 of the split tag while the linked portion becomes the Part2 of the split tag.
	Link User AELINKUSER	Links simple text (that is not an attribute definition or part of geometry) as User (01-99) attributes on an AutoCAD Electrical block file. The entity value is used as the user value for one or more template block definitions. If only one template block is selected for the link, the text entity is removed and replaced with the user attribute, up to 99. Window selection is allowed.
	Link Rating AELINKRATING	Links simple text as Rating 1-12 attributes on an AutoCAD Electrical block file. The entity value is used as the rating value for one or more template block definitions. If only one template block is selected for the link, the text entity is removed and replaced with the rating attribute, up to 12.
	Link Item Number AELINKITEM	Links simple text as an Item Number attribute on an AutoCAD Electrical Panel block file. During the conversion process, the text entity is removed and replaced with the Item Number attribute (P_ITEM).

	Command	Description
	Show Links AESHOWLINK	Selects the tagged template block file and displays everything (such as description, location, manufacturer, and catalog number codes) that has been linked to it.
	Un Link AEUNLINK	Selects an existing linked attribute and unlinks the attribute from the symbol, changing the attribute to AutoCAD text.

## Symbol Builder tab

### Edit panel

The Symbol Builder tab is displayed automatically when you use Symbol Builder.

	Command	Description
	Save Symbol Definition AESAVESYM	Displays the Save Symbol Definition dialog box.
	Symbol Audit AESYMAUDIT	Displays the Symbol Audit dialog box.
	Show Hide Symbol Block Editor Palette AEPALLETESHOW	Switches on and off the visibility of the symbol builder attribute editor window.

## Help panel

The Symbol Builder tab is displayed automatically when you use Symbol Builder.

	Command	Description
	Symbol Builder Help	Displays the Symbol builder Help.

## Toolbars to Ribbons

### Main Electrical toolbar

#### Command Access



Schematic tab ► Insert Components panel ► Insert Components drop-down ► Icon Menu.



Schematic tab ► Insert Components panel ► Insert Components drop-down ► Catalog



List.



Schematic tab ► Insert Components panel ► Insert Components drop-down ► Equipment



List.



Schematic tab ► Insert Components panel ► Insert Components drop-down ► Panel List.



---

## Command Access

---



Schematic tab ► Insert Components panel ► Insert Components drop-down ► Terminal

(Panel List).



Schematic tab ► Edit Components panel ► Swap/Update Block.



Schematic tab ► Edit Components panel ► Copy Component.



Schematic tab ► Insert Components panel ► Multiple Insert drop-down ► Multiple Insert

(Icon Menu).



Schematic tab ► Insert Components panel ► Multiple Insert drop-down ► Multiple Insert

(Pick Master).



Schematic tab ► Insert Components panel ► Dashed Link Line drop-down ► Link Com-

ponents with Dashed Line.



Schematic tab ► Insert Components panel ► Dashed Link Line drop-down ► Insert Refer-

ence Arrow - To.



---

## Command Access

---



Schematic tab ► Insert Components panel ► Dashed Link Line drop-down ► Insert Reference Arrow - From.



Schematic tab ► Insert Components panel ► Insert PLC drop-down ► Insert PLC (Parametric).



Schematic tab ► Insert Components panel ► Insert PLC drop-down ► Insert PLC (Full Units).



Import/Export Data tab ► Import panel ► Unity Pro.



Import/Export Data tab ► Import panel ► RSLogix 500.



Import/Export Data tab ► Import panel ► PLC I/O Utility.



Schematic tab ► Other Tools panel ► Database Editors drop-down ► PLC





Database File Editor.







---

## Command Access



---

 Schematic tab ► Insert Components panel ► Insert Connector drop-down ► Insert Connector.  

 Schematic tab ► Insert Components panel ► Insert Connector drop-down ► Insert Connector (From List).  

 Schematic tab ► Edit Components panel ► Modify Connectors drop-down ► Reverse Connector.  

 Schematic tab ► Edit Components panel ► Modify Connectors drop-down ► Rotate Connector  

 Schematic tab ► Edit Components panel ► Modify Connectors drop-down ► Stretch Connector.  

 Schematic tab ► Edit Components panel ► Modify Connectors drop-down ► Split Connector.  

 Schematic tab ► Edit Components panel ► Modify Connectors drop-down ► Add Connector Pins.  

---

---

### Command Access

---



Schematic tab > Edit Components panel > Modify Connectors drop-down > Delete



Connector Pins.



Schematic tab > Edit Components panel > Modify Connectors drop-down > Move Con-



connector Pins.



Schematic tab > Edit Components panel > Modify Connectors drop-down > Swap Con-



connector Pins.



Schematic tab > Insert Components panel > Insert Connector drop-down > Insert Splice.



Schematic tab > Insert Components panel > Circuit drop-down > Insert WBlocked Circuit.



Schematic tab > Insert Components panel > Circuit drop-down > Insert Saved Circuit.



Schematic tab > Edit Components panel > Circuit drop-down > Copy Circuit.





---

## Command Access

---



Schematic tab > Edit Components panel > Circuit drop-down > Move Circuit.



Schematic tab > Edit Components panel > Circuit drop-down > Save Circuit to Icon

Menu.



Schematic tab > Edit Components panel > Edit Components drop-down > Edit.



Schematic tab > Edit Components panel > Edit Components drop-down > Internal

Jumper.



Schematic tab > Edit Components panel > Edit Components drop-down > Fix/Unfix Tag.



Schematic tab > Edit Components panel > Edit Components drop-down > Copy Catalog

Assignment.



Schematic tab > Edit Components panel > Edit Components drop-down > User Table

Data.



---

## Command Access

---



Schematic tab ► Edit Components panel ► Retag Components drop-down ► Retag

Components.



Schematic tab ► Edit Components panel ► Retag Components drop-down ►

Find/Edit/Replace Component Text.



Schematic tab ► Edit Components panel ► Retag Components drop-down ► Find/Replace

Terminal Text.



Project tab ► Project Tools panel ► Update/Retag.



Schematic tab ► Edit Components panel ► Modify Components drop-down ► Scoot.



Schematic tab ► Edit Components panel ► Modify Components drop-down ► Align.



Schematic tab ► Edit Components panel ► Modify Components drop-down ► Move

Component.



---

## Command Access

---



Schematic tab ► Edit Components panel ► Modify Components drop-down ► Reverse/Flip



Component.

---



Schematic tab ► Edit Components panel ► Modify Components drop-down ► Stretch



PLC Module.

---



Schematic tab ► Edit Components panel ► Modify Components drop-down ► Split PLC



Module.

---



Schematic tab ► Edit Components panel ► Modify Attributes drop-down ► Move/Show



Attribute.

---



Schematic tab ► Edit Components panel ► Modify Attributes drop-down ► Edit Selected



Attribute.

---



Schematic tab ► Edit Components panel ► Modify Attributes drop-down ► Hide Attribute



(Single Pick).

---



Schematic tab ► Edit Components panel ► Modify Attributes drop-down ► Add Attribute.



---

### Command Access

---



Schematic tab ► Edit Components panel ► Modify Attributes drop-down ► Squeeze Attribute/Text.



Schematic tab ► Edit Components panel ► Modify Attributes drop-down ► Stretch Attribute/Text.



Schematic tab ► Edit Components panel ► Modify Attributes drop-down ► Change Attribute Size.



Schematic tab ► Edit Components panel ► Modify Attributes drop-down ► Rotate Attribute.



Schematic tab ► Edit Components panel ► Modify Attributes drop-down ► Change Attribute Justification.



Schematic tab ► Edit Components panel ► Modify Attributes drop-down ► Change Attribute Layer.



Schematic tab ► Edit Components panel ► Toggle NO/NC.



---

## Command Access

---



Schematic tab ► Edit Components panel ► Delete Component.



Schematic tab ► Insert Wires/Wire Numbers panel ► Insert Wires drop-down ► Wire.



Schematic tab ► Insert Wires/Wire Numbers panel ► Multiple Bus.



Schematic tab ► Insert Wires/Wire Numbers panel ► Insert Wires drop-down ► 22.5 Degree.



Schematic tab ► Insert Wires/Wire Numbers panel ► Insert Wires drop-down ► 45 Degree.



Schematic tab ► Insert Wires/Wire Numbers panel ► Insert Wires drop-down ► 67.5 Degree.



Schematic tab ► Edit Wires/Wire Numbers panel ► Modify Wires drop-down ► Bend Wire.



---

## Command Access

---



Schematic tab > Insert Wires/Wire Numbers panel > Insert Wires drop-down > Interconnect

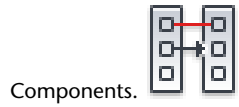

Schematic tab > Insert Wires/Wire Numbers panel > Insert Wires drop-down > Gap.



Schematic tab > Edit Wires/Wire Numbers panel >  > Modify Wire Gap drop-down



Schematic tab > Edit Wires/Wire Numbers panel >  > Modify Wire Gap drop-down



Schematic tab > Edit Wires/Wire Numbers panel >  > Modify Wire Gap drop-down



Schematic tab > Edit Wires/Wire Numbers panel > Modify Wire Type drop-down >

Change/Convert Wire Type.

---

---

## Command Access

---



Schematic tab ► Edit Wires/Wire Numbers panel ► Modify Wire Type drop-down ► Cre-

ate/Edit Wire Type.



Schematic tab ► Edit Wires/Wire Numbers panel ► Modify Wires drop-down ► Stretch

Wire.



Schematic tab ► Edit Wires/Wire Numbers panel ► Modify Wires drop-down ► Show

Wires.



Schematic tab ► Edit Wires/Wire Numbers panel ► Modify Wires drop-down ► Check/Trace

Wire.



Schematic tab ► Edit Wires/Wire Numbers panel ►  ► Wire Sequence drop-down

► Edit Wire Sequence.



Schematic tab ► Edit Wires/Wire Numbers panel ►  ► Wire Sequence drop-down



► Show Wire Sequence.





---

## Command Access



---

 Schematic tab > Edit Components panel >  > Terminal: Show Internal/External Connections.



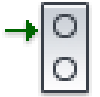

 Schematic tab > Edit Components panel >  > Terminal: Mark Internal Connections.



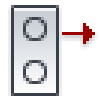

 Schematic tab > Edit Components panel >  > Terminal: Mark External Connections.





 Schematic tab > Edit Components panel >  > Terminal: Erase Internal/External Connections.



 Schematic tab > Insert Wires/Wire Numbers panel > Cable Markers drop-down > Cable Markers.



 Schematic tab > Insert Wires/Wire Numbers panel > Cable Markers drop-down > Multiple Cable Markers.



---



---

## Command Access

---



Schematic tab ► Insert Wires/Wire Numbers panel ► Insert Dot, Tee Markers drop-down



► Insert Dot Tee Markers.



Schematic tab ► Insert Wires/Wire Numbers panel ► Insert Dot, Tee Markers drop-down



► Insert Angled Tee Markers.



Schematic tab ► Edit Wires/Wire Numbers panel ►  ► Toggle Angled Tee Markers.



Schematic tab ► Insert Wires/Wire Numbers panel ► Insert Ladder drop-down ► Insert



Ladder.



Schematic tab ► Edit Wires/Wire Numbers panel ► Modify Ladder drop-down ► Revise



Ladder.



Schematic tab ► Edit Wires/Wire Numbers panel ► Modify Ladder drop-down ► Renumber



Ladder Reference.



Schematic tab ► Insert Wires/Wire Numbers panel ► Insert Ladder drop-down ► XY Grid



Setup.

---

---

### Command Access

---



Schematic tab ► Insert Wires/Wire Numbers panel ► Insert Ladder drop-down ► X Zones



Schematic tab ► Edit Wires/Wire Numbers panel ► Modify Ladder drop-down ► Add



Schematic tab ► Edit Wires/Wire Numbers panel ► Trim Wire.

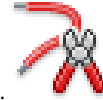

---

## Main Electrical 2 toolbar

---

### Command Access

---



Schematic tab ► Insert Wires/Wire Numbers panel ► Insert Wire Numbers drop-down ►

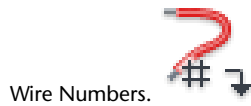

Schematic tab ► Insert Wires/Wire Numbers panel ► Insert Wire Numbers drop-down ►



Schematic tab ► Insert Wires/Wire Numbers panel ► Insert Wire Numbers drop-down ►

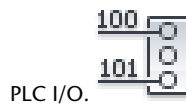

---

## Command Access

---



Schematic tab > Insert Wires/Wire Numbers panel > Wire Number Leader drop-down >



Wire Number Leader.



Schematic tab > Insert Wires/Wire Numbers panel > Wire Number Leader drop-down >



Wire Color/Gauge Labels.



Schematic tab > Insert Wires/Wire Numbers panel > Wire Number Leader drop-down >



In-Line Wire Labels.



Schematic tab > Edit Wires/Wire Numbers panel > Copy Wire Number drop-down >



Copy Wire Number.



Schematic tab > Edit Wires/Wire Numbers panel > Copy Wire Number drop-down >



Copy Wire Number In-Line.



Schematic tab > Edit Wires/Wire Numbers panel > Copy Wire Number drop-down >



Adjust In-Line Wire/Label Gap.



Schematic tab > Edit Wires/Wire Numbers panel > Move Wire Number.



---

### Command Access

---



Schematic tab > Edit Wires/Wire Numbers panel > Modify Wire Numbers drop-down >

Edit Wire Number.



Schematic tab > Edit Wires/Wire Numbers panel > Modify Wire Numbers drop-down >

Fix.



Schematic tab > Edit Wires/Wire Numbers panel > Modify Wire Numbers drop-down >

Swap.



Schematic tab > Edit Wires/Wire Numbers panel > Modify Wire Numbers drop-down >

Find/Replace.



Schematic tab > Edit Wires/Wire Numbers panel > Modify Wire Numbers drop-down >

Hide.



Schematic tab > Edit Wires/Wire Numbers panel > Modify Wire Numbers drop-down >

Unhide.



Schematic tab > Edit Wires/Wire Numbers panel > Flip Wire Number.



---

## Command Access

---



Schematic tab > Edit Wires/Wire Numbers panel > Toggle Wire Number In-line.

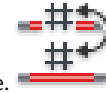

Schematic tab > Insert Wires/Wire Numbers panel > Signal Arrows drop-down > Source



Schematic tab > Insert Wires/Wire Numbers panel > Signal Arrows drop-down > Destin-



Schematic tab > Edit Wires/Wire Numbers panel >  > Update Signal References.



Schematic tab > Insert Wires/Wire Numbers panel > Signal Arrows drop-down > Fan In



Schematic tab > Insert Wires/Wire Numbers panel > Signal Arrows drop-down > Fan Out



Schematic tab > Edit Wires/Wire Numbers panel >  > Fan In/Out - Single Line



---

## Command Access

---



Schematic tab > Edit Wires/Wire Numbers panel >  > List Signal Code.

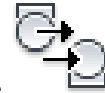

Schematic tab > Edit Wires/Wire Numbers panel >  > Show Signal Paths.



Reports tab > Schematic panel > Signal Error/List.



Schematic tab > Insert Wires/Wire Numbers panel > Signal Arrows drop-down > Reference

Only Arrows.



Schematic tab > Edit Wires/Wire Numbers panel > Delete Wire Numbers.



Schematic tab > Other Tools panel > Symbol Builder drop-down > Symbol Builder.



Schematic tab > Other Tools panel > Icon Menu Wizard.



Project tab > Other Tools panel > Migration Utility.



---

## Command Access

---



Schematic tab > Edit Components panel >  > Associate Terminals.

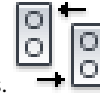

Schematic tab > Edit Components panel >  > Break Apart Terminal Associations.



Schematic tab > Edit Components panel >  > Copy Terminal Block Properties.



Schematic tab > Edit Components panel > Modify Component Cross-Reference drop-down

> Component Cross-Reference.



Schematic tab > Edit Components panel > Modify Component Cross-Reference drop-down

> Hide/Unhide Cross-Referencing.



Schematic tab > Insert Components panel > Dashed Link Line drop-down > Insert Stand-

Alone Cross-Referencing.



Schematic tab > Edit Components panel > Modify Component Cross-Reference drop-down

> Update Stand-Alone Cross-Referencing.



---

## Command Access

---



Schematic tab ► Edit Components panel ► Modify Component Cross-Reference drop-down



► Change Cross-Reference to Multiple Line Text.

---



Schematic tab ► Edit Components panel ► Modify Component Cross-Reference drop-down



► Cross-Reference Check.

---



Schematic tab ► Edit Components panel ► Modify Component Cross-Reference drop-down



► Child Location/Description Update.

---



Schematic tab ► Edit Components panel ► Modify Component Cross-Reference drop-down



► Copy/Add Component Override.

---



Schematic tab ► Edit Components panel ► Modify Component Cross-Reference drop-down



► Remove Component Override.

---



Schematic tab ► Insert Components panel ► Location Box drop-down ► Location Symbols.



Schematic tab ► Insert Components panel ► Location Box drop-down ► Location Box.





---

## Command Access

---



Schematic tab > Edit Components panel >  > Copy Installation/Location Code



Project tab > Other Tools panel > Surfer drop-down menu > Surfer.



Project tab > Other Tools panel > Surfer drop-down > Continue Surfer.



Project tab > Other Tools panel > Previous DWG.



Project tab > Other Tools panel > Next DWG.



Reports tab > Schematic panel > Reports.



Reports tab > Schematic panel > Missing Catalog Data.



Reports tab > Schematic panel > Electrical Audit.



---

## Command Access

---



Reports tab ► Schematic panel ► DWG Audit.



Reports tab ► Miscellaneous panel ► Report Format Setup.



Reports tab ► Miscellaneous panel ► Automatic Reports.



Reports tab ► Miscellaneous panel ► User Attributes.



Import/Export Data tab ► Export panel ► Inventor.



Import/Export Data tab ► Export panel ► Unity Pro.



Import/Export Data tab ► Export panel ► To Spreadsheet.



Import/Export Data tab ► Import panel ► From Spreadsheet.



Import/Export Data tab ► Import panel ► From Project MDB.



---

## Command Access

---



Import/Export Data tab ► Import panel ► Spreadsheet to Table.



Schematic tab ► Other Tools panel ► Drawing Properties drop-down ► Drawing Properties.



Schematic tab ► Other Tools panel ► Drawing Properties drop-down ► Rename Layers.



Schematic tab ► Other Tools panel ► Drawing Properties drop-down ► Settings Compare.



Project tab ► Project Tools panel ► Manager.



Project tab ► Project Tools panel ► Copy.



Project tab ► Project Tools panel ► Update/Retag.



Project tab ► Project Tools panel ► Utilities.



---

### Command Access

---



Project tab ► Project Tools panel ► Mark/Verify DWGs.



Project tab ► Other Tools panel ► Language Conversion.



Project tab ► Other Tools panel ► Edit Language Database.



tab ► panel ► Rebuild/Freshen Project Database.



---

## Panel Layout toolbar

---

### Command Access

---



Panel tab ► Insert Component Footprints panel ► Insert Footprints drop-down ► Icon



Menu.



Panel tab ► Insert Component Footprints panel ► Insert Footprints drop-down ►



Schematic List.



Panel tab ► Insert Component Footprints panel ► Insert Footprints drop-down ► Manual.



---

## Command Access

---



Panel tab ► Insert Component Footprints panel ► Insert Footprints drop-down ► Manu-



facturer Menu.

---



Panel tab ► Insert Component Footprints panel ► Insert Footprints drop-down ► Catalog



List.

---



Panel tab ► Insert Component Footprints panel ► Insert Footprints drop-down ► Equip-



ment List.

---



Panel tab ► Terminal Footprints panel ► Editor.



Panel tab ► Terminal Footprints panel ► Table Generator.



Panel tab ► Terminal Footprints panel ►  ► Insert Terminals drop-down ► Insert



Terminal (Schematic List).

---



Panel tab ► Terminal Footprints panel ►  ► Insert Terminals drop-down ► Insert



Terminal (Manual).

---

---

## Command Access

---



Panel tab ► Edit Footprints panel ► Copy Footprint.



Panel tab ► Edit Footprints panel ► Edit.



Panel tab ► Other Tools panel ► Panel Configuration drop-down ► Make Xdata Visible.



Panel tab ► Insert Component Footprints panel ► Balloon.



Panel tab ► Insert Component Footprints panel ► Wire Annotation.



Reports tab ► Panel panel ► Reports.



tab ► panel ► Rebuild/Freshen Project Database.



Panel tab ► Insert Component Footprints panel ► Panel Assembly.



Panel tab ► Edit Footprints panel ► Copy Assembly.



---

## Command Access

---



Panel tab ► Edit Footprints panel ► Copy Codes drop-down ► Copy Installation Code.



Panel tab ► Edit Footprints panel ► Copy Codes drop-down ► Copy Location Code.



Panel tab ► Edit Footprints panel ► Copy Codes drop-down ► Copy Mount Code.



Panel tab ► Edit Footprints panel ► Copy Codes drop-down ► Copy Group Code.



Panel tab ► Edit Footprints panel ► Resequence Item Numbers.



Panel tab ► Other Tools panel ►



Footprint Database File Editor.



Schematic tab ► Other Tools panel ►



Database Editors drop-down ► Schem-

atic Database File Editor.



---

### Command Access

---



Panel tab ► Other Tools panel ► Panel Configuration drop-down ► Rename Layers.



Panel tab ► Other Tools panel ► Panel Configuration drop-down ► Update Layers.



Panel tab ► Other Tools panel ► Panel Configuration drop-down ► Configuration.



---

## Conversion toolbar

---

### Command Access

---



Conversion Tools tab ► Tools panel ► Special Explode.



Conversion Tools tab ► Tools panel ► Block Replacement drop-down ► Block Replacement.



Conversion Tools tab ► Tools panel ► Promise Conversion.



Conversion Tools tab ► Schematic panel ► Tag Component.





---

## Command Access

---



Conversion Tools tab ► Schematic panel ► Tag PLC Module.



Conversion Tools tab ► Schematic panel ► Tag Child Component.



Conversion Tools tab ► Schematic panel ► Tag Child Contacts drop-down ► Tag Child -



Conversion Tools tab ► Schematic panel ► Tag Child Contacts drop-down ► Tag Child -



Conversion Tools tab ► Schematic panel ► Tag Child Contacts drop-down ► Tag Child -



Conversion Tools tab ► Schematic panel ► Tag Schematic Terminals drop-down ► Tag

Schematic Terminal - Terminal Number.



Conversion Tools tab ► Schematic panel ► Tag Schematic Terminals drop-down ► Tag

Schematic Terminal - Wire Number.



---

## Command Access

---



Conversion Tools tab ► Schematic panel ► Tag Schematic Terminals drop-down ► Tag



Schematic Terminal - Wire Number Change.

---



Conversion Tools tab ► Attributes panel ► Link Descriptions.



Conversion Tools tab ► Attributes panel ► Link Split Tag.



Conversion Tools tab ► Attributes panel ► Link PLC Address Descriptions.



Conversion Tools tab ► Attributes panel ► Link Terminal Number.



Conversion Tools tab ► Attributes panel ► Link Location Code.



Conversion Tools tab ► Attributes panel ► Link Installation Code.



Conversion Tools tab ► Attributes panel ► Link Manufacturer.



Conversion Tools tab ► Attributes panel ► Link Catalog Number.



---

## Command Access

---



Conversion Tools tab > Attributes panel > Link Rating.



Conversion Tools tab > Attributes panel > Link User.



Conversion Tools tab > Attributes panel > Show Links.



Conversion Tools tab > Attributes panel > Un-Link.



Conversion Tools tab > Tools panel > Add Wire Connections.



Conversion Tools tab > Tools panel > Add Geometry.



Conversion Tools tab > Panel panel > Tag Footprint.



Conversion Tools tab > Panel panel > Tag Nameplate.



Conversion Tools tab > Panel panel > Tag Panel Terminal - Terminal Number.



---

## Command Access

---



Conversion Tools tab ► Panel panel ► Tag Panel Terminal - Wire Number.



Conversion Tools tab ► Attributes panel ► Link Descriptions.



Conversion Tools tab ► Attributes panel ► Link Split Tag.



Conversion Tools tab ► Attributes panel ► Link Item Number.



Conversion Tools tab ► Attributes panel ► Link Location Code.



Conversion Tools tab ► Attributes panel ► Link Installation Code.



Conversion Tools tab ► Attributes panel ► Link Manufacturer.



Conversion Tools tab ► Attributes panel ► Link Catalog Number.



Conversion Tools tab ► Attributes panel ► Link Rating.



---

## Command Access

---



Conversion Tools tab > Attributes panel > Link User.



Conversion Tools tab > Attributes panel > Show Links.



Conversion Tools tab > Attributes panel > Un-Link.



Conversion Tools tab > Tools panel > Add Wire Connections.



Conversion Tools tab > Tools panel > Add Geometry.



Conversion Tools tab > Tools panel > Convert Ladder.



Conversion Tools tab > Tools panel > Change/Convert Wire Type drop-down >

Change/Convert Wire Type.



Conversion Tools tab > Tools panel > Text Conversion drop-down > Convert Text to Wire

Number.



---

## Command Access

---



Conversion Tools tab > Tools panel > Schematic Conversion drop-down > Convert Block



to Source Arrow.



Conversion Tools tab > Tools panel > Schematic Conversion drop-down > Convert Block



to Destination Arrow.



Conversion Tools tab > Tools panel > Change/Convert Wire Type drop-down >



Check/Repair Gap Pointers.



Conversion Tools tab > Tools panel > Stretch Wire.



Conversion Tools tab > Tools panel > Change Attribute Size.



Conversion Tools tab > Tools panel > Add Attribute.



Conversion Tools tab > Tools panel > Text Conversion drop-down > Convert Text to At-



tribute Definition.



Conversion Tools tab > Tools panel > Xdata Editor.



---

### Command Access

---



Conversion Tools tab > Tools panel > Schematic Conversion drop-down > Convert to



Schematic Component.

---



Conversion Tools tab > Tools panel > Map Attributes from Old to New.



Conversion Tools tab > Tools panel > Block Replacement drop-down > Swap/Update



Block.

---

## Conduit Marker toolbar

---

### Command Access

---



Panel tab > Conduit Marker panel > Conduit Markers drop-down > Insert Marker.



Panel tab > Conduit Marker panel > Conduit Markers drop-down > Insert From List.



Panel tab > Conduit Marker panel > Edit Marker.



---

### Command Access

---



Panel tab ► Conduit Marker panel ► Conduit Reports drop-down ► Conduit Report.



Panel tab ► Conduit Marker panel ► Conduit Reports drop-down ► Routing Report.



Panel tab ► Conduit Marker panel ► Conduit Reports drop-down ► Extract Wire Data.



---

## Power Check toolbar

---

### Command Access

---



Schematic tab ► Power Check panel ► Add/Edit Source/Load.



Schematic tab ► Power Check panel ► Mark Components To Pass Power.



Schematic tab ► Power Check panel ► Load Check Report.





## Extra Libraries toolbar

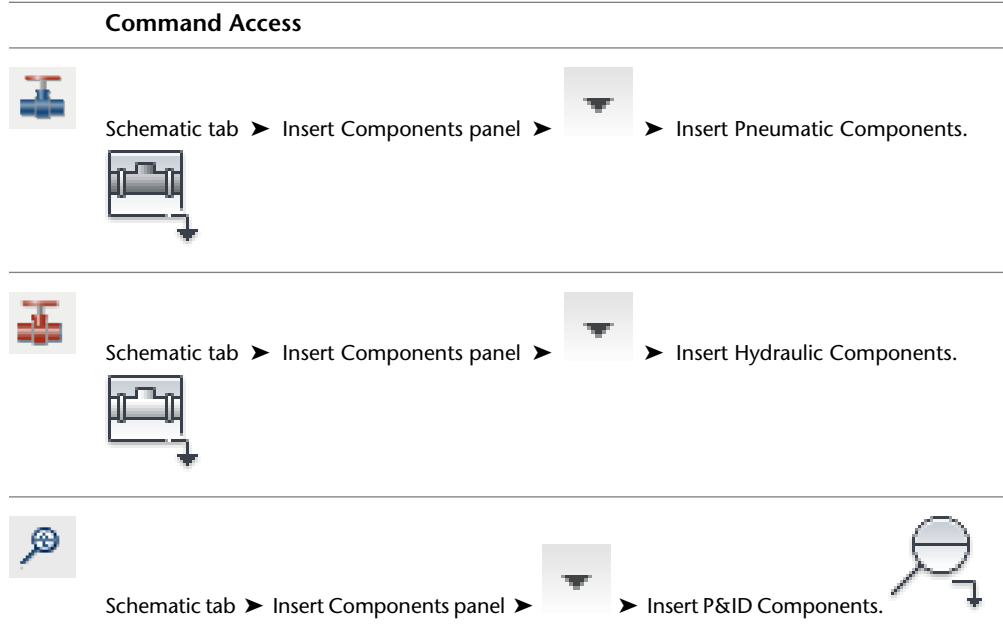

## The Ribbon

**The ribbon is a palette that displays task-based tools and controls.**

### Overview of the Ribbon

The ribbon is displayed by default when you open a file, providing a compact palette of all of the tools necessary to create or modify your drawing.

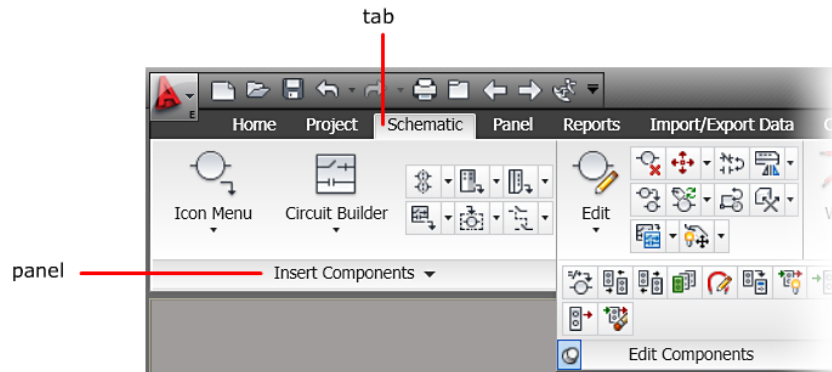

## Display and Organize the Ribbon

The horizontal ribbon is displayed across the top of the file window. You can dock the vertical ribbon to the left or right of the file window.

The vertical ribbon can also float in the file window or on a second monitor.

### Ribbon Tabs and Panels

The ribbon is composed of a series of panels, which are organized into tabs labeled by task. Ribbon panels contain many of the same tools and controls available in toolbars and dialog boxes.

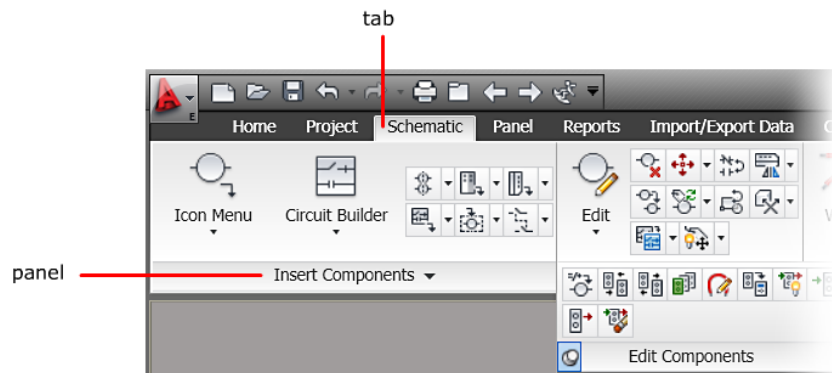

Some ribbon panels display a dialog box related to that panel. The dialog box launcher is denoted by an arrow icon, , in the lower-right corner of the

panel. The dialog box launcher indicates that you can display a related dialog box. Display the related dialog box by clicking the dialog box launcher.



To specify which ribbon tabs and panels are displayed, right-click the ribbon and, on the shortcut menu, click or clear the names of tabs or panels.

### Floating Panels

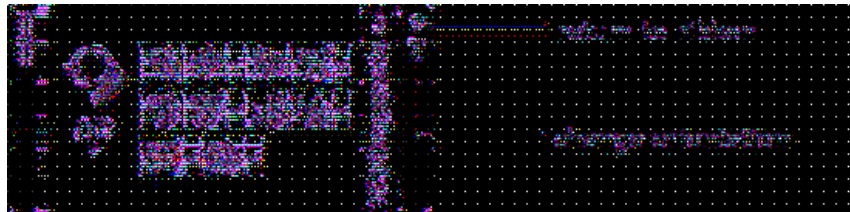
If you pull a panel off of a ribbon tab and into the drawing area or onto another monitor, that panel floats where you placed it. The floating panel remains open until you return it to the ribbon, even if you switch ribbon tabs.



### Slideout Panels

An arrow in the middle of a panel title, , indicates that you can slide out the panel to display additional tools and controls. Click on the title bar of an open panel to display the slideout panel. By default, a slideout panel automatically closes when you click another panel. To keep a panel expanded, click the push pin, , in the bottom-left corner of the slideout panel.

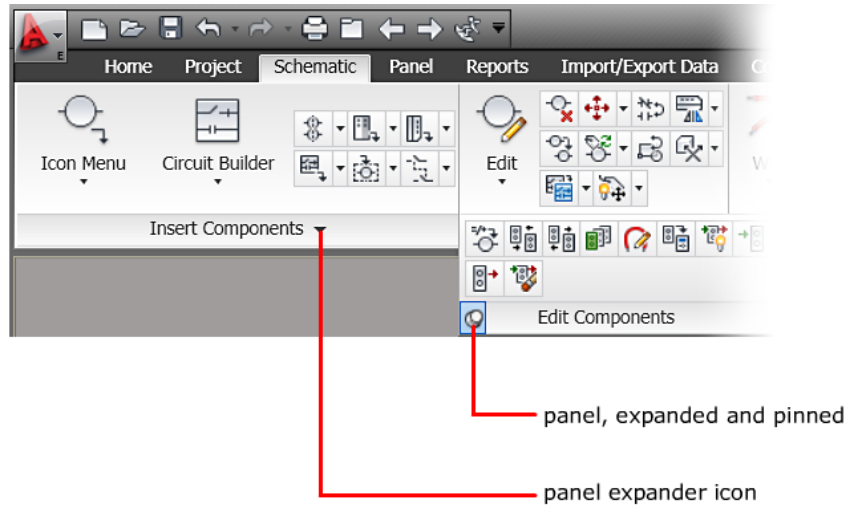

## Contextual Ribbon Tabs

When you select a particular type of object or execute some commands, a special contextual ribbon tab is displayed instead of a toolbar or dialog box. The contextual tab is closed when you end the command.

## To display the ribbon

- Click Tools menu ► Palettes ► Ribbon.

---

**NOTE** The ribbon displays the ribbon panels associated with the workspace you used last.

---

To display the ribbon panels associated with a specific workspace, click Tools menu ► Workspaces.

 **Command entry:** RIBBON

## To close the ribbon

- At the Command prompt, enter **ribbonclose**.

 **Command entry:** RIBBONCLOSE

## To minimize the ribbon

There are two buttons to the right of the ribbon tabs, that allow you choose the ribbon toggle and ribbon minimize states.

- The first button toggles the between the full ribbon state, the default ribbon state, and the minimize ribbon state.
- The second drop-down button allows you to select the minimize ribbon state. These are the four minimize ribbon states:
  - **Minimize to Tabs:** Minimizes the ribbon so that only tab titles are displayed.
  - **Minimize to Panel Titles:** Minimizes the ribbon so that only tab and panel titles are displayed.
  - **Minimize to Panel Buttons:** Minimizes the ribbon so that only tab titles and panel buttons are displayed.
  - **Cycle Through All:** Cycles through all four ribbon states in the order, full ribbon, minimize to panel buttons, minimize to panel titles, minimize to tabs.

## To minimize the ribbon

**Pointing device:** Double-click the name of the active ribbon tab or anywhere in the ribbon tab bar.

## To return a floating panel to the ribbon

- Hover over the right side of the floating panel and click the Return Panels to Ribbon icon.

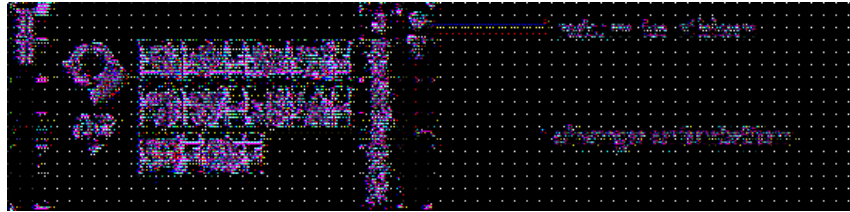

## To display or hide a ribbon panel

- Right-click anywhere inside the ribbon. Under Panels, select or unselect the name of a panel.

## To show or hide text labels on ribbon panels

- Right-click the ribbon tab bar and click Show Panel Titles.

## Customize the Ribbon

### You can customize the ribbon in the following ways:

- You can create and modify ribbon panels using the Customize User Interface Editor. See Customize Ribbon Panels in the *AutoCAD Customization Guide*.
- You can associate a customizable tool palette group with each tab on the ribbon. Right-click the ribbon tab to display a list of available tool palette groups.
- You can change the order of ribbon tabs. Click the tab you want to move, drag it to the desired position, and release.
- You can change the order of ribbon panels. Click the panel you want to move, drag it to the desired position, and release.

- You can convert toolbars into ribbon panels using the Customize User Interface Editor. See *Customize Ribbon Panels* in the *AutoCAD Customization Guide*.

### **To display the tool palette group associated with a ribbon**

- Right-click a ribbon tab and click Show Related Tool Palette Group.

# Migration

# 2

## Migration Utility

The Migration Utility migrates settings and files from a previous AutoCAD Electrical release to the current release. Many files within AutoCAD Electrical are customizable. The Migration Utility migrates these custom changes to the current release. You select which files to migrate and which migration option to use. There are three migration workflows:

- Migrate from an earlier release
- Custom migration
- Migrate from saved settings

---

**NOTE** The Merge Utility, used to merge database files and panel content, is no longer a separate utility. It is now part of the Migration Utility.

---

### Files types for migration

The Migration Utility supports many file types. Various default folders are searched for these file types. The following default paths are searched by the Migration Utility. You can have the Migration Utility look in other folders.

- **Install folder** - C:\Program Files\Autodesk\AcadE {version}\
- **User Support folder** - C:\Documents and Settings\{username}\Application Data\Autodesk\AutoCAD Electrical {version}\R17.0\{language}\Support\
- **Program Support folder** - C:\Program Files\Autodesk\AcadE {version}\Support\

- **Data folder** - C:\Documents and Settings\{username}\My Documents\AcadE {version}\AeData\
- **Project folder** - C:\Documents and Settings\{username}\My Documents\AcadE {version}\AeData\Proj
- **Library folder** - C:\Program Files\Autodesk\AcadE {version}\Libs\
- **User folder** - C:\Documents and Settings\{username}\Application Data\Autodesk\AutoCAD Electrical {version}\R17.0\{language}\Support\User\
- **Catalog folder** - C:\Documents and Settings\{username}\My Documents\AcadE {version}\AeData\Catalogs
- **PLC folder** - C:\Documents and Settings\{username}\My Documents\AcadE {version}\AeData\PLC

There are two migration options depending on the file type.

- **Merge** - compare the two files and merge the data according to the selected options. If overwrite is not selected, only new lines are merged.
- **Copy** - copy the file in the current version to the selected file. If overwrite is not selected, only new files are copied.

Use this table to see which files the Migration Utility supports, the default search paths, and the available migration options for each file type.

File Type	Default Folder	File	Migration Options
Environment File	Data	wd.env	Copy or Merge
Symbol menu	User Support	*.dat	Copy or Merge
Library menu images	User Support	*.dll and *.slb	Copy
Miscellaneous slide images	User Support	*.sld and *.png	Copy
Style images	PLC and Install\acade	*.bmp	Copy
Catalog database	Catalogs	default_cat.mdb	Copy or Merge
Footprint lookup database	Catalogs	footprint_lookup.mdb	Copy or Merge



<b>File Type</b>	<b>Default Folder</b>	<b>File</b>	<b>Migration Options</b>
Schematic lookup database	Catalogs	schematic_look-up.mdb	Copy
PLC database	PLC	ace_plc.mdb	Copy or Merge
Pick list database	Catalogs	wd_picklist.mdb	Copy
Dinrail	Catalogs	wddinrl.xls	Copy
Language conversion data-base	Catalogs	wd_lang1.mdb	Copy
Library symbols	Library	all folders	Copy
User circuits	User	*.dwg	Copy
Drawing templates	Registry template path	*.dwt	Copy
Table styles	Program support	tablestyle.dwg	Copy or Merge
Line types	User Support	Acade.lin	Copy or Merge
Recent project list	User Support	lastproj.fil	Copy
Installation, Location, Mount, Group code	User	*.inst, *.loc, *.mnt, *.grp	Copy
Description list	User Support	*.wdd	Copy
Rating defaults	User Support	*.wdr	Copy
External component tag list	User	*.wdx	Copy
Spreadsheet to PLC setup	User	*.wdi	Copy
Equipment list setup	User	*.wde	Copy
Wire color/gauge label	User	*.wdw	Copy
Terminal number filter	Project	*.wdn	Copy

File Type	Default Folder	File	Migration Options
Terminal strip table setup	User	*.tsl	Copy
Conduit setup	Program Support	*.wwl	Copy
Plot paper size	Program Support	Generic paper size.txt	Copy
Title block mapping	Project	*.wdt	Copy
Title block line label mapping	User	*.wdl	Copy
Family tag mapping	User	wd_fam.dat	Copy
PLC mapping	User Support	wdmbblks.bsf	Copy
RSlogix code mapping	Program Support	*.wdf	Copy
Unity Pro symbol mapping	User	*.map	Copy
User-defined attributes	User	*.uda	Copy
Report settings	User	*.set	Copy
Report groups	User	*.rgf	Copy

### Table mapping file for catalog merges

You can choose to impose an input mapping file to direct where to place the data inside the catalog destination database. The mapping file (named ACEDBMergeUtil.map) is located in the same directory as the main executable program.

**NOTE** There are additional mappings for vendors, catalog numbers, and fields. See the mapping file for information about these mappings. The default file location is *C:\Program Files\Autodesk\AcadE {version}\*.

To consolidate all the timer relay (TD) tables into one table, use the mapping file. It controls which tables to take from the source database and place into the destination database under a single table.

[Table map]

; <SRC\_TABLE>=<DEST\_TABLE>

TD1N=TD

TD1NT=TD

TD1NF=TD

TD1FT=TD

Wildcard mapping for catalog database tables is allowed on the source (left) database side of the mapping file. For example, TD\*=TD. When the table or wildcard mapping is used and the source database table is component-specific, the merge utility places the table name into the WDBLKNAM field of the destination database. It provides the symbol name for the initial filter used in the catalog lookup window.

### Table mapping files for footprint lookup database merges

A mapping file for the footprint lookup database (ACEDBMergeUtil\_footprint\_lookup.map) is provided. This file follows the same rules as the mapping file for catalog merges (ACEDBMergeUtil.map). No rules are predefined in this mapping file. The file is a framework that needs to be modified to provide customized merges.

---

**NOTE** The default file location is *C:\Program Files\Autodesk\AcadE {version}\*. See the file for further instructions on how to format and construct the mapping strings.

---

### PLC Database

The Spreadsheet to PLC/IO utility uses the module category to calculate the insertion point of a module.

- **Input module** - inserted near the right or bottom bus line of the ladder.
- **Output module** - inserted near the left or top bus line of the ladder.
- **Combination module** - inserted centered between the bus lines of the ladder.

Before AutoCAD Electrical 2009, the Spreadsheet to PLC/IO utility determined the module category based on the value in the DESCRIPTION field or the PLC database table name. For example, if the DESCRIPTION field contained the string *"\*IN\*"*, it was considered an input module. In AutoCAD Electrical 2009 and later, the PLC database contains a CATEGORY field. If the PLC database

file is migrated, the Migration Utility automatically runs the PLC Database Migration utility using the following default settings.

<b>Input</b>	DI*,AI*,*INP*,*IN *,*IN,*IN/*
<b>Output</b>	DO*,AO*,D0*,A0*,*OUT*
<b>Combination</b>	*OTHER*,IO*,IO*

The PLC Database Migration utility compares the values in the DESCRIPTION field of the PLC database to default values for input, output, or combination. If a match is not made, the database table name is compared. If a match is made to the DESCRIPTION field or table name, the correct CATEGORY value is entered for that module.

- 1 - Input module
- 2 - Output module
- 3 - Combination module

The PLC Database Migration utility updates all tables in the PLC database based on these values.

---

**NOTE** Blank spaces within the text are included as part of the search string. For example, "IN{space}\*" matches "IN module" but does not match "INPUT".

---

### **wd.env merge**

The wd.env file can contain settings that direct AutoCAD Electrical where to locate certain files. These files can include the catalog and lookup databases, slide libraries, and user circuits. The paths from the migrated wd.env file are used when these dependent files are migrated.

For example:

<b>Migration Option</b>	<b>Previous version wd.env</b>	<b>Current version wd.env</b>	<b>Final wd.env</b>
Merge - Overwrite	WD_CAT=n:\shared\	WD_CAT={default path}	WD_CAT=n:\shared\
Merge	WD_CAT=n:\shared\	WD_CAT={default path}	WD_CAT={default path}

If you also select the catalog database for migration, the data from the source catalog database is migrated to the destination catalog database based on the selected migration options, for example merge - overwrite. The suggested destination folder for the migrated catalog database is the path in the migrated wd.env.

If you change the migration status of the wd.env file, you are prompted to update these dependent files to make sure that the location of each file matches the wd.env settings.

### Log file

Each time you run the Migration Utility, the migration information is written to the file acemigration.log. This log file contains the date of the migration, the user name, and information about the files migrated. The log file is stored in the User folder. The default location is:

- **Windows XP:** C:\Documents and Settings\{username}\Application Data\Autodesk\AutoCAD Electrical {version}\{release number}\{country code}\Support\User\
- **Windows Vista, Windows 7:**  
C:\Users\{username}\AppData\Roaming\Autodesk\AutoCAD Electrical {version}\{release number}\{country code}\Support\User\

### Back-up copies

A back-up copy of each migrated file is made. The back-up file is created in the same directory as the original file and its name is the same as the original, but with the extension ".bak."

---

**NOTE** Backup copies are not created for library symbol drawing files and slide images.

---

### Migrating from an earlier release

The Migration Utility migrates your settings and customized files from an earlier release of AutoCAD Electrical to the current release.



- 1 Click Project tab ► Other Tools panel ► Migration Utility.

AutoCAD Electrical searches for previous installations of AutoCAD Electrical.

- 2 Select the release to migrate from.  
AutoCAD Electrical searches for files from the selected release. Existing files are selected for migration by default.
- 3 Click the category name in the Migration items list. The files within that category are shown in the Migration files section.
- 4  Click within the Copy/Merge Option cell, and select the Browse tool to change the migration option for a file. The Copy/Merge Options dialog box opens. Different file types have different migration options.
- 5 Select the Copy/Merge option, including whether to overwrite or not, and select OK.
- 6 Click within the Source cell and browse to change the source file.
- 7 Click within the Destination cell and browse to change the destination file.
- 8 Select OK. The Migration Review dialog box opens.
- 9 (optional) Select Save As to save the migration settings to a file to use to migrate from these saved settings.
- 10 Review the migration items.
- 11 Select OK.
- 12 Review the Migration Complete information.
- 13 Select Done.

## Custom migration

Use the Migration Utility to migrate settings and customized files. When you select a custom migration, you define each file that you want to migrate. This option is useful when you have files from an earlier release that are not in the default location. This option is also used to synchronize multiple computers.



- 1 Click Project tab ► Other Tools panel ► Migration Utility.
- 2 Select Migrate from: <Custom>.
- 3 Check the box next to the category name.

- 4 Click the category name in the Migration items list.
- 5 Click within the Source cell and type the file name or browse to the file you want to migrate.
- 6 Click within the Destination cell and type the file name or browse to the destination file.
- 7  Click within the Copy/Merge Option cell, and select the Browse tool to change the migration option for the file. The Copy/Merge Options dialog box opens. Different file types have different migration options.
- 8 Select the Copy/Merge option and select OK.
- 9 Repeat for each file you want to migrate.
- 10 Select OK. The Migration Review dialog box opens.
- 11 (optional) Select Save As to save the migration settings to a file that to use to migrate from these saved settings.
- 12 Review the migration items.
- 13 Select OK.
- 14 Review the Migration Complete information.
- 15 Select Done.

## Migrating from saved settings

Migrating from saved settings is useful if you migrate settings and files on multiple computers. You define the migration settings on the first computer and save those settings to an external file. When you use the Migration Utility on another computer select the file containing the saved settings.

### Saving the settings file

- 1 Click Project tab ► Other Tools panel ► Migration Utility. 
- 2 Set your migration settings using either the steps for [Migrating from an earlier release](#) on page 129 or a [Custom migration](#) on page 130.
- 3 Select OK on the AutoCAD Electrical Migration Utility dialog box. The Migration Review dialog box opens.

- 4 Select Save As to save the migration settings to a file.
- 5 Enter a file name and click Save.
- 6 Continue the migration or Cancel.

### Migrating from the saved settings file

- 1 Click Project tab ► Other Tools panel ► Migration Utility.
- 2 Select External File to migrate from the saved settings.
- 3 Select the saved .migr file and click Open.
- 4 Review the migration items.
- 5 Select OK.
- 6 Review the Migration Complete information.
- 7 Select Done.



## AutoCAD Electrical Migration Utility

Migrates settings and files from a previous AutoCAD Electrical release to the current release.

 **Ribbon:** Project tab ► Other Tools panel ► Migration Utility.



 **Toolbar:** Miscellaneous



 **Menu:** Projects ► Extras ► Migration Utility

 **Command entry:** AEMIGRATION

Many files and settings within AutoCAD Electrical are customizable. Select which files and settings to migrate to the current release, and which option to use:

- Migrate from an earlier release.
- Custom migration.
- Migrate from saved settings.



## Migrate from

Select to migrate from a previous version of AutoCAD Electrical or to perform a custom migration. All installed AutoCAD Electrical versions, 2004 or newer, are options in the dialog box list. Click External file to browse to a previously saved migration settings file.

## Migration items

Available migration items are listed in a tree structure. Select a file category check box if you want to migrate files from that category. If you are migrating from a previous version of AutoCAD Electrical, any existing files are selected for migration by default. If the category contains additional subcategories, expand the tree structure to see each level. Highlight the category name to display the individual files and migration options within the Migration files section.

## Migration files

The Migration files section lists the files, and migration options, for the category highlighted in the Migration items section. Use this section to change the migration option, source file, or destination file.

### Copy/Merge Options

Displays the current migration option. To change the migration option for a file, select within the Copy/Merge Options cell.



Opens the Copy/Merge Options dialog box.

Copy/Merge options differ depending on the selected file type.

### Source

Displays the current source file or folder for migration. To change the source file, select within the Source cell



Opens the Select source file dialog box.

### Destination

Displays the current destination file or folder for migration. To change the destination file, select within the Destination cell



Opens the Select destination file dialog box.

### Remove

Remove the selected files from the list of file for migration.

### Preview

Opens a preview dialog box showing the migration changes for the selected file. The Preview button is available only when mer-

ging the Environment File, Symbol Menu, or Line Type. Red text indicates changed lines. Blue text indicates added lines.

## Merge/Copy Options

The Migration Utility supports various file types for migration to the current release of AutoCAD Electrical. Different file types have different migration options. There are two file migration options: copy or merge.

### Copy

If the Copy option is selected, the source file is copied to the file location for the current release. You can choose to overwrite any existing destination files. If you choose not to overwrite the existing files, only new files are migrated.

### Merge

If the Merge option is selected, you can choose to overwrite existing entries. You can indicate to maintain the user fields, text value field, and Web hyperlink field in overwritten records when merging catalog databases. If you choose not to overwrite existing entries, only new entries are merged.

## Migration Options

Provides options for merging the PLC database file.

The Spreadsheet to PLC/IO utility uses the module category to calculate the insertion point of a module.

- **Input module** - inserted near the right or bottom bus line of the ladder.
- **Output module** - inserted near the left or top bus line of the ladder.
- **Combination module** - inserted centered between the bus lines of the ladder.

Before AutoCAD Electrical 2009, the Spreadsheet to PLC/IO utility determined the module category based on the value in the DESCRIPTION field or the database table name. For example, if the DESCRIPTION field contained the string “\*IN\*”, it was considered an input module. In AutoCAD Electrical 2009 and later, the PLC database contains a CATEGORY field.

The Migration utility compares the values in the DESCRIPTION field of the PLC database to values you assign as input, output, or combination. If a match is not made, the database table name is compared. If there is a match to the

DESCRIPTION field or table name, the CATEGORY value is entered for that module.

- 1 - Input module
- 2 - Output module
- 3 - Combination module

<b>Input</b>	Enter text, comma delimited, used to match to the DESCRIPTION value. If there is a match, the module is assigned a CATEGORY value of 1 for input.
<b>Output</b>	Enter text, comma delimited, used to match to the DESCRIPTION value. If there is a match, the module is assigned a CATEGORY value of 2 for output.
<b>Combination</b>	Enter text, comma delimited, used to match to the DESCRIPTION value. If there is a match, the module is assigned a CATEGORY value of 3 for combination.
<b>Overwrite existing settings</b>	Select to overwrite any existing CATEGORY values. If not selected, only blank CATEGORY fields are modified.

The Migration utility updates all tables in the PLC database based on these values.

---



**NOTE** Blank spaces within the text are included as part of the search string. For example, "IN{space}\*" matches "IN module" but does not match "INPUT".

---

If no match is made for a module, the CATEGORY field is not modified. Use the PLC Database File Editor to assign a category to a module. Select a "Spreadsheet to PLC I/O Utility Insertion Point" option on the [Module specifications](#) on page 614 dialog box.

## Migration Review

 **Ribbon:** Project tab ► Other Tools panel ► Migration Utility. 

 **Toolbar:** Miscellaneous 

 **Menu:** Projects ► Extras ► Migration Utility

 **Command entry: AEMIGRATION**

The Migration Review dialog box opens after selecting OK on the AutoCAD Electrical Migration Utility dialog box. The dialog box displays all the migration items and the options for each item.

<b>Files selected for migration</b>	<b>Status:</b> indicates the migration option, such as Merge/Overwrite or Copy/Overwrite. <b>Source:</b> name and path of the file containing the data to migrate. <b>Destination:</b> name and path of the file to receive the values from the source file.
<b>Save As</b>	Opens the Save Settings dialog box. Enter a file name to save the migration settings. This file is used when migrating from an <a href="#">external file</a> on page 131.

# Project Management

# 3

## Overview of projects

A project is a set of interrelated wiring diagram drawings. An ASCII text file, called the project file, lists the AutoCAD drawing file names that make up the wiring diagram set. You can have as many projects as you wish, but only one project can be active at a time.

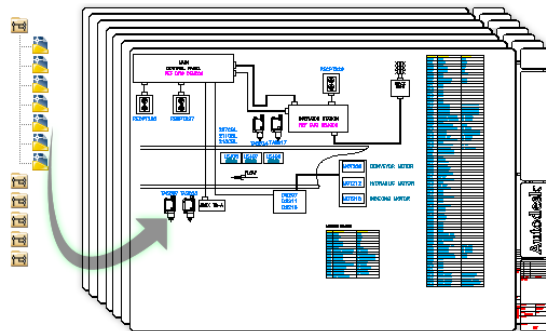

An AutoCAD Electrical project file:

- Is an ASCII text file with any path and any name followed by the .WDP extension.
- Lists the complete path to each wiring diagram drawing included in the project.
- Carries default settings that can be referenced when new drawings are created and added to the project.

Project files default to the directory pointed to by your project subdirectory (given by the WD\_PROJ setting in your environment file). It is not mandatory. When you create a project file, you can save it to any subdirectory. In some cases, you may want to store them in client-specific subdirectories to take advantage of the AutoCAD Electrical ability to access client-specific catalog files and library symbols.

### Use recently opened projects

The Project Manager displays a list of recently opened projects so you can easily select another project to open without having to browse for it. The project list is dynamic with the last project you worked on appearing at the top of the list. The list of recent projects is saved in a text file called lastproj.fil in the user subdirectory.



- **Windows XP:** \Documents and Settings\{username}\Application Data\Autodesk\AutoCAD Electrical {version}\{release}\{country code}\Support\User\
- **Windows Vista, Windows 7:**  
\Users\{username}\AppData\Roaming\Autodesk\AutoCAD Electrical {version}\{release}\{country code}\Support\User\

Each line in this file gives the information for one project. The last piece of data in the line identifies what the project state is when AutoCAD Electrical is started: "2"=Active, "1"=listed as Open, "0"= not listed in window but available from the Recent Projects dialog box. If you adjust this file, either manually with a text editor or programmatically (see the AutoCAD Electrical API Help), you can control which project is active when AutoCAD Electrical starts up, and which other projects are shown in the Project Manager window.

### Work with projects

Use the Project Manager to create a project, access an existing project, add drawings to a project, or modify existing information associated with a project.

#### Create a project

- 1 Click Project tab ► Project Tools panel ► Manager. 
- 2  On the Project Manager, click the New Project button.

---

**NOTE** You can also create a project by right-clicking at the bottom of the tree inside the Project Manager and selecting New Project or by clicking the arrow on the Project Selection menu and selecting New Project.

---

- 3 In the Create New Project dialog box, enter the name for the new project. The .WDP extension is automatically added to the filename.
- 4 Select or create the directory where you want to save the project.
- 5 (Optional) Specify an existing project file (WDP) to use. Use the default or click Browse to select a previously defined project definition file.
- 6 (Optional) Click Descriptions to enter descriptions for the project. You can enter up to 12 description lines per page. You can also select the check boxes for the information to include in reports generated for the project.
- 7 (Optional) Click OK-Properties to modify your project default settings for project settings, components, wire numbering, cross-references, styles, and drawing formats. All information defined in these tabs is saved to the project definition file as project and drawing defaults.
- 8 Click OK.

### Add a new drawing to the current project

- 1 Click Project tab ► Project Tools panel ► Manager. 

- 2  On the Project Manager, click the New Drawing button.
- 3 [Create a new drawing](#) on page 167 and click OK.
- 4 In the Project Manager, right-click the project name and select Add Active Drawing. The drawing is added to the end of the existing list.

### Add existing drawings to the current project

- 1 Click Project tab ► Project Tools panel ► Manager. 

- 2 In the Project Manager, right-click the project name, and select Add Drawings.
- 3 In the Select Files to Add dialog box, select the drawings to add to the current project. You can select multiple drawings using the Shift or Control keyboard keys.

---

**NOTE** The order in which you select drawings determine how they are listed in the project drawing list.

---

- 4 Click Add.  
The drawings are added to end of the project drawing list.

## Copy a project

Copies an existing project and project specific files to a new name, and creates renamed copies of the drawing files.

Before you run the Copy Project operation, close the drawings you plan to copy. The copied project becomes the active project.



- 1 Click Project tab ► Project Tools panel ► Copy.
- 2 Enter the name of the project to copy.
  - Click Copy active project to copy the current project.
  - Click Browse to select a project to copy.
- 3 Click OK.
- 4 Select the directory where you want to save the new project.
- 5 Enter the name for the new project. The .WDP extension is automatically added to the filename.
- 6 Click Save.
- 7 Select one or more drawings to copy to the new project.
  - **Do All:** Selects all drawings from the project drawing list to copy to the new project.
  - **Process:** Selects one or more drawings from the project drawing list to copy to the new project.



- **Reset:** Moves all selected drawings back to the project drawing list.
- **Un-select:** Moves one or more drawings back to the project drawing list.
- **by Section/sub-section:** Selects drawings by sections and subsections.

- 8 Click OK.
- 9 Enter the directory path where to save the new project. If the directory does not exist, it is created.
- 10 Select the project-related files to copy. (See the following list.)
- 11 Click OK.
- 12 Modify the new drawing file names if necessary.
- 13 Click OK. The new project becomes the current project.

#### **Project-related files to copy**

On the Copy Project: Step 4 -- Enter Base Path for Project Drawings dialog box you can select the project-related files to copy to the new path. Options include:

- Title block setup (.wdt)
- Project line labels (.wdl)
- Component description defaults (.wdd)
- Catalog lookup database (cat.mdb)
- Footprint lookup database (lookup.mdb)
- Family code mapping (wd\_fam.dat)
- Wire color/gauge label (.wdw)
- Schematic lookup database (schematic\_lookup.mdb)
- Location codes (.loc)
- Installation codes (.inst)
- Ratings defaults (.wdr)
- Component tagging (.wdx)

- Spreadsheet PLC I/O Utility settings (.wdi)
- RSLogix import mapping (.wdf)
- User-defined attributes (.wda)
- Terminal audit filter (.wdn)

## Work with project drawings

Use the Project Manager to access an existing project and modify its associated information.

### Group drawings within a project

You can create groups of drawings within your project list by assigning sections and subsection codes to each drawing. The AutoCAD Electrical project-wide tagging, cross-referencing, and reporting functions can then operate on the whole project (default) or, using this section/subsection coding, on just a portion of the drawing set.

- 1 Click Project tab ► Project Tools panel ► Manager. 
  - 2 In the Project Manager, right-click the drawing name, and select Properties ► Drawing Properties.
  - 3 In the Drawing Properties dialog box, click the [Settings](#) on page 220 tab.
  - 4 In the Sheet Values section, enter a section or subsection code for the drawing.
  - 5 Click OK.
- Repeat for each drawing you want to group, making sure to assign the same section or subsection code to each.

### Change the order of drawings in the project

The order in which drawings appear in the drawing list of the project is the order in which AutoCAD Electrical processes them in project-wide tagging and cross-referencing operations. You can change the drawing order using the Reorder Drawings tool.

- 1 Click Project tab ► Project Tools panel ► Manager. 
- 2 In the Project Manager, right-click the project name, and select Reorder Drawings.
- 3 Find and highlight the drawing you want to move in the list.
- 4 Click Move Up or Move Down until the drawing moves to the appropriate position in the list.
- 5 Click OK.

### Remove a drawing from the active project

- 1 Click Project tab ► Project Tools panel ► Manager. 
- 2 In the Project Manager, right-click the drawing name, and select Remove. The drawing is instantly removed from the project but it is not deleted.

---

**NOTE** You can remove all drawings from a project by right-clicking the project name in the Project Manager, and selecting Remove Drawings. Select the drawings to remove from the Select Drawings to Process dialog box, and click OK.

---

### Assign a description to each drawing

You can assign a 3-line description to each drawing listed in your project. You can then toggle the project drawing list back and forth between drawing preview and drawing details. Flipping the drawing list to display the drawing details can make it easier to find a specific drawing among dozens or hundreds in a project file.

- 1 Click Project tab ► Project Tools panel ► Manager. 
- 2 In the Project Manager, right-click the drawing name, and select Properties ► Drawing Properties.
- 3 In the Drawing Properties ► [Settings](#) on page 220 dialog box, enter a description for the drawing.

Select from a list of predefined descriptions from the active project by clicking the arrow.

- 4 Click OK.

---

**TIP** These descriptions can link to an attribute in the title block for automatic update.

---

### Preview a drawing

You can preview a drawing from the Project Manager.



- 1 Click Project tab ► Project Tools panel ► Manager.
- 2 In the Project Manager, select a drawing from the list.
- 3 In the Details pane, click Preview.

An image of the highlighted drawing displays. Once selected, the preview remains on. Each time you highlight another drawing in the project list the display updates with an image of the selected drawing.

- 4 Click Details to return to the drawing description for the drawings.

### Pick a different project

AutoCAD Electrical displays a list of recently opened projects so you can easily select another project to open without having to browse for it. The project list is dynamic with the last project you worked on appearing at the top of the list. The list of recent projects is saved in a text file called lastproj.fil in the user subdirectory.



- 1 Click Project tab ► Project Tools panel ► Manager.
- 2 In the Project Manager, click the arrow on the Project Selection menu, and select Recent.
- 3 In the Recent Projects dialog box, select the project from the list.
- 4 Click Drawings to see a list of the drawings in the selected project.

In the Project Drawings dialog box, double-click a drawing name to see a preview of that drawing. Click Pick Project, Open Drawing to make the

selected project the active project and open the selected drawing or click Back to return to the Recent Projects dialog box.

- 5 (Optional) Click Remove to remove a project from the project list.
- 6 Click OK.

The selected project becomes the active project.

---

**NOTE** If you know the drawing name but you are not sure what project the drawing is in, click Find in the Recent Projects dialog box. In the Find Drawing in Recent Projects dialog box, enter the name of the drawing (wildcards are accepted) and click Find. Once a list of possible projects is presented, select the project name and click Drawing List to see a list of the drawings contained in the project. Double-click the drawing name in the list to preview the drawing. Click Pick Project, Open Drawing to activate the project and open the selected drawing.

---

## Project manager

Opens or creates a project of one or more drawings, and configures project-wide settings.

 **Ribbon:** Project tab ► Project Tools panel ► Manager. 

 **Toolbar:** Main Electrical 2 

 **Menu:** Projects ► Project ► Project Manager

 **Command entry:** AEPROJECT

Lists the drawing files associated with each open project. Add new drawings, reorder drawing files, and change project settings. Right-click the properties icon for options to move, size, close, dock, hide, or set the transparency for the Project Manager.

You can dock the Project Manager into a specific location on the screen or hide it until you want to use the project tools. Right-click the properties icon to display options to move, size, close, dock, hide, or set the transparency for the Project Manager.

---

**NOTE** You cannot have two projects open in the Project Manager with the same project name.

---

### Right-click menu

You can right-click in empty space in the Project Manager to display the following options:

<b>New Project</b>	Creates a project. Once created, the new project automatically becomes the active project.
<b>Open Project</b>	Opens a different project from a file selection dialog box. In the Select Project File dialog box, navigate to the project to open and select it.
<b>New Drawing</b>	Creates a drawing file and adds it to the active project. The new drawing displays at the bottom of the project drawing list for the active project.

### Project Selection menu

You can default to a predefined directory by adding an entry to your .env file. Exit AutoCAD and open the .env file with any generic text editor (such as Wordpad). Add this line:

```
WD_PICKPRJDLG, n:/{your directory}/, AutoCAD Electrical default pick proj
```

<b>Recent</b>	Opens a different project from a list of recent projects or from a file selection dialog box.
<b>New Project</b>	Creates a project. Once created, the new project automatically becomes the active project.
<b>Open Project</b>	Opens a different project from a file selection dialog box. In the Select Project File dialog box, navigate to the project to open and select it.
<b>Open Project from Vault</b>	Allows you to browse to the vault to open a project and make it active inside of the Project Manager. You must be logged into the vault. In the Select Project dialog box, navigate to the project to open and select it. Click the arrow next to the Open button and select one of the following options: Open (Check Out), Open (Check Out All), or Open Read-only.

## Buttons



### New Project

Creates a project. Once created, the new project automatically becomes the active project.



### New Drawing

Creates a drawing file and adds it to the active project.



### Refresh

Refreshes the drawing list inside of the Project Manager.

For Vault: Checks for changes in external file references and updates the Vault icons in the Project Manager. Files that have changed and are currently checked out to you are not updated. Files that are checked out to someone else are updated to their current version. Files that are checked out to someone else are updated to their current version on your local drive. If the Vault version is newer, then the Vault icon indicates that the file needs reloading (the Vault icon turns red).



### Project Task List

Performs pending updates on any drawing files inside of the active project that have been modified.



### Project-Wide Update/Re-tag

Updates the related line reference numbers, cross-reference text, device tagging, and signal reference updates on the selected drawing files inside of the active project.



### Drawing List Display Configuration

Configures the display options. There are ten values that can be associated with the drawings listed so you can display the information based on your requirements.



### Publish/Plot

Batch plots one or more drawings in the active project.

## Projects

Displays all the open projects in a list. You can have as many projects open as you need, but only one project can be active at a time. The active project appears in bold text and is always found at the top of the list. Right-click the project name to display the following project editing options:

<b>Descriptions</b>	Edits the project descriptions. Displays unlimited lines describing the project. Descriptions can then be included in report headers and title blocks.
<b>Title Block Update</b>	Automates updating title block information for the active drawing or for the entire project drawing set.
<b>Drawing List Report</b>	Generates a report that lists project drawing information from the title blocks such as drawing descriptions, section, and file names. On the Drawing List Report dialog box, select to run a new report, redisplay the previously run report or select a format .set file to use for the report.
<b>New Drawing</b>	Creates a drawing file and adds it to the active project.
<b>Add Drawings</b>	Adds one or more drawings to the active project. When prompted, specify whether to apply the project default values to the drawing settings (in the WD_M block definition).
<b>Add Active Drawing</b>	Adds an active drawing to the active project. The new drawing appears at the end of the project drawing list. When prompted, specify whether to apply the project default values to the drawing settings (in the WD_M block definition).
<b>Reorder Drawings</b>	Moves drawings up or down in the drawing list for the project. The order determines how the drawings are processed for project-wide tagging and cross-referencing operations.
<b>Remove Drawings</b>	Removes one or more drawings from the current project. <hr/> <b>NOTE</b> The drawing file is not deleted, just the reference to the drawing. <hr/>
<b>Task List</b>	Performs pending updates on any drawing files inside of the active project that have been modified.
<b>Publish</b>	Launches dialog boxes to plot the project, publish to the Web, publish to DWF, or create a zip file of the project.



<b>Settings</b>	Displays the settings for the project and information about the AutoCAD Electrical environment.
<b>Exception List</b>	Displays a list of drawing files that have different settings from the project definition file (.wdp). If all drawing files match the .wdp, the dialog box indicates that there are no exceptions. You can then use the Settings Compare tool to display the differences.
<b>Properties</b>	Controls project-wide settings including tagging, component cross-referencing options, and catalog lookup file preferences.
<b>Activate</b>	Makes an open project the active project in the AutoCAD Electrical session. This option also sends the project list to the top of the dialog box.
<b>Close</b>	Closes an open project. <hr/> <b>NOTE</b> You cannot close the active project; first activate another project in the list. <hr/>
<b>Vault</b>	You must be logged into the vault to see this menu in the Project Manager. The status of the selected object determines which vault commands are available for selection.  <b>Check In All</b> Adds the project definition file (.wdp) along with its drawing files to the vault. You can vault just the project file using the Project Check In command. You can vault the project file along with its drawing files using the project Check In All command. <hr/> <b>NOTE</b> If files used to support the project (such as .wdl and .wdt) share the same file name as the project, they appear in the Vault Check In All dialog box. <hr/> <b>Check Out All</b> Reserves and locks the project definition file along with the associated drawing files listed in the Project Manager. If the project definition file is unavailable for checkout, you can

still check out the drawings available for editing.

**Check In**

Adds the project definition file to the vault and creates a version of the file. Use this option if you want to check in only the project definition file and none of its drawing file dependencies; otherwise use Check In All.

---

**NOTE** If files used to support the project (such as .wdl and .wdt) share the same file name as the project, they appear in the Vault Check In dialog box.

---

**Check Out**

Reserves and locks the master project definition file. Retrieves an updated copy, if necessary. Use this option if you want to check out only the project definition file and none of its drawing file dependencies; otherwise use Check Out All.

**Undo Check Out/Undo Check Out All**

Removes the reservation/lock from the master project definition file. The master file is now available for others to check out. Any modifications made to the local copy are not checked back into the vault.

Undo Check Out All removes the lock from all the checked out drawing files and project definition file listed in the Project Manager for the selected project.

**Get Latest/Get Latest All**

Retrieves the latest master copy from the vault and copies it into your working folder. The status indicator displaying a red background indicates older files.

## Project Drawing List

Displays the drawings associated with a project. You can select multiple drawings from the project list to open, close, remove, apply project defaults, or paste properties all at once. You cannot select multiple drawings from two or more projects.

The active drawing appears in bold text in the list. By default, the selected drawing highlights in the project drawing list regardless if the Project Manager is active or not. You can turn off this feature by clicking the Drawing List Display Configuration button and selecting Show selection highlight only when active.



Indicates that the file is a drawing file.



Indicates that a drawing file is a reference drawing. To make a drawing a reference drawing, right-click on the drawing name and select Properties ► Drawing Properties.

Right-click the drawing name to display the following drawing editing options:

- |                |  |
|----------------|--|
| <b>Open</b>    | Opens the selected drawing in a new window. You can also double-click a drawing name or select a drawing name and press Enter to open the drawing.   |
| <b>Close</b>   | Closes the selected drawing.   |
| <b>Copy To</b> | Copies the selected drawing into the same or another open project. Select the folder to copy the drawing to, enter a new file name and select the project to save the drawing to. When prompted, specify whether to apply the project default values to the drawing settings (in the WD_M block definition). |
| <b>Remove</b>  | Removes the selected drawing from the current project.   |
| <b>Replace</b> | Replaces the selected drawing with one that you select from a file selection dialog box.   |
| <b>Rename</b>  | Renames the selected drawing directly in the drawing list.   |

<b>Drawing Properties</b>	Assigns, edits, and removes section and subsection coding for a drawing. Assigns drawing descriptions to the drawing files.
<b>Apply Project Defaults</b>	Applies project settings to new drawing files where the project default settings for the drawings were not applied at creation time.
<b>Copy</b>	Copies the drawing settings and options from one drawing to one or more drawings. <hr/> <b>NOTE</b> Drawing-specific information (found on the Drawing Properties ► Drawing Settings tab) cannot be copied from one drawing to another. <hr/>
<b>Paste</b>	Applies the copied drawing settings and options from one drawing to the selected drawings.
<b>Settings Compare</b>	Displays differences between all drawing settings and their associated defaults in the project definition file.
<b>Check In</b>	(you must be logged into the vault) Adds a file to the vault and creates a version of the file. The first time drawing file is checked in, the project definition file is checked in at the same time. The project definition file is vaulted first to establish a location in the Vault database.
<b>Check Out</b>	(you must be logged into the vault) Reserves and locks the master drawing file. Retrieves an updated copy, if necessary. Checks out the drawing files when the project file is under Vault control.
<b>Undo Check Out</b>	(you must be logged into the vault) Removes the reservation/lock from the master drawing file. The master file is now available for others to check out. Any modifications made to the local copy are not checked back into the vault.
<b>Get Latest</b>	(you must be logged into the vault) Retrieves the latest master copy from the vault and copies it into your working folder. The status indicator displaying a red background indicates older files.

---

**NOTE** Two projects can reference the same drawing file. If both projects try to modify the same drawing with a project-wide tagging or cross-referencing function it can lead to conflicts.

---

### Details



Switches between displaying drawing previews and drawing descriptions. The drawing details are updated when you highlight a drawing file and remain visible until a new drawing file is selected. Use the up and down arrow keys on your keyboard to switch drawings.







<b>Details</b>	Displays project and drawing detail based on what is highlighted in the Project pane. Information listed includes the status, file name, file location, file size, last saved date, and the name of the last user who modified the file.
<b>Preview</b>	Displays the last saved thumbnail view for the highlighted drawing in the drawing list.

### Vault Status Icons

(you must be logged into the vault) The Vault Status Icons indicate the status of your local copy of the files as compared against the master copy of those same files in the vault.







The Vault Status indicate when the local copy is in sync with the master and when it is not. The tooltips help guide you to the next logical steps - especially when the local copy is no longer in sync with the master. These icons are crucial to the overall understanding of how to work in a vaulted environment.

<b>Icon</b>	<b>Meaning</b>
	File is not in the vault.
	File is in the vault and available to be checked out. The version in your working folder is the same as in the vault. Also referred to as the Latest Version.
	File is in the vault and available to be checked out, but the local version is newer than the latest version in the vault. This status typically means that your local file was changed without checking it out. If you want to save these changes, check out the file with the Don'tGet Local Copy option.

-  File is in the vault and available to be checked out, but the local copy is out of date. Get the latest version from the vault.
-  File is checked out to you and the local version is the same as in the vault. Also referred to as the Latest Version.
-  File is checked out to you and the local copy is newer than the latest version in the vault. This status typically means that you changed the file since it was checked out but have not checked it back in.
-  File is checked out to you and the local copy is older than the latest version in the vault. This status typically means that you started with a version for the vault that was older than the latest version, and then checked it out to promote it to the latest.
-  File is checked out by someone else, and the local copy is the same as in the vault. Also referred to as the Latest Version. This condition typically occurs if the other person did not check changes back into the vault.
-  File is checked out to someone else, but the local copy is newer than the latest version in the vault. This condition typically occurs if the other person checked changes into the vault, but kept the file checked out. Use Refresh from Vault to update to the latest available version.
-  File is checked out to someone else, but the local copy is older than the latest version in the vault. Use Refresh from Vault to update to the latest available version.

## Create new project

Defines the minimum requirements to create an AutoCAD Electrical project definition file (WDP), the folder in which the project is maintained, and the settings and options defined within the project.

-  **Ribbon:** Project tab > Project Tools panel > Manager. 
-  **Toolbar:** Main Electrical 2 
-  **Menu:** Projects > Project > Project Manager
-  **Command entry:** AEPROJECT

Click the New Project button or select New Project from the Project Selection menu.

---

**NOTE** You can also create a project by right-clicking at the bottom of the tree inside the Project Manager, and selecting New Project.

---

<b>Name</b>	<p>Specifies the name for the new project. Enter a name to define any of the project properties.</p> <hr/> <p><b>NOTE</b> The .wdp extension is not required in the edit box.</p> <hr/>
<b>Location</b>	<p>Specifies the location for a project definition file and folder definition. If left blank, the project definition file is created at the WD.ENV project location. Click Browse to pick a folder where the new project file/folder is created.</p> <hr/> <p><b>NOTE</b> You cannot have duplicate project names in the same location.</p> <hr/>
<b>Create Folder with Project Name</b>	<p>Creates a folder with the same name as the project where the drawing files and project definition are stored. The folder is created following the path defined in the project location edit box.</p>
<b>Copy Settings from Project File</b>	<p>Specifies the project settings. You can select a previously defined project setting and apply it to your new project definition file. Click Browse to select a previously defined project definition file to copy over and apply settings to the new project being created.</p> <hr/> <p><b>NOTE</b> If blank, copies the settings from the active project.</p> <hr/>
<b>Descriptions</b>	<p>Specifies the project descriptions. Descriptions can be included in report headers and title blocks</p>
<b>OK-Properties</b>	<p>Creates the project definition file in the specified location before opening the Project Properties dialog box where you can define default settings and options for your project which are saved in the project definition file.</p>

## Copy project: step 1 - select existing project to copy

 **Ribbon:** Project tab ► Project Tools panel ► Copy.



 **Toolbar:** Project



 **Menu:** Projects ► Project ► Copy Project

 **Command entry:** AECOPYPROJECT

---

**NOTE** If the active drawing is one of them to copy to a new project, cancel the dialog box, open a new drawing, and then restart the Copy Project command.

---

<b>Copy Active Project</b>	Copies the active project.
<b>Browse</b>	Selects another project to copy.

## About collaborative design

In a collaborative design environment, several people can work on a project at the same time. The project file (.WDP) lists all the drawings that are part of a project. You can use Autodesk Vault with AutoCAD Electrical for drawing management, version control, and revision labeling.

You must install Autodesk Vault to vault projects. Autodesk Vault prevents engineers from working on the original version of a project in the vault. To maintain the relationship between the drawing files that are defined in the project file, check out all files specified in a project file to modify one or more files. When edits are complete, the project can be checked back into the vault.

AutoCAD Vault ARX adds vaulting functionality to the Project Manager. Upon initial start-up of AutoCAD Electrical, you are not logged into the vault. Log into Autodesk Vault using the File ► Vault menu to vault projects. The vault commands are available by right-clicking a project or drawing within the AutoCAD Electrical Project Manager. You can use the Project Manager to:

### ■ Check projects in and out of the vault

The most basic requirement of the vault is that you never work directly on a file in the vault. The projects in the vault are the Masters and cannot be edited. Check out the project to the working folder on your local drive



to edit it. When you finish working on the project, check the project back into the vault.

---

**TIP** Other people can view updates you made to a project while you continue modifying the project. Select the Keep Checked Out option on the Check In dialog box. It checks in the updates you made to the project and keeps the project checked out to you.

---

**NOTE** You must have all references of a project file downloaded to your working folder to edit the project file.

---

■ **View the status of files in a design.**

Vault status icons indicate the status of your local copy of the files as compared against the master copy of those same files in the vault. The vault status icons indicate when the local copy is in sync with the master and when it is not. Tooltips provide descriptions of the icons. Pause the cursor over a status icon to see a detailed description. The tooltips also help guide you to the next logical steps, especially when the local copy is no longer in sync with the master. The vault status icons are crucial to the overall understanding of how to work in a vaulted environment.

---

**NOTE** The vault status icons are only available in the list view and only appear when you are logged into the vault.

---

### Key Concepts

- The master files are stored and maintained in the file store on the Vault server. The vault database is also located on the server. It can be on the same or a different server from where the file store is located. The database maintains the metadata for the files in the file store and the relationships between those files.
- The vault is referred to as the virtual location of the files. Users do not work directly on the master files. A file must be checked out from the virtual location in the vault to a physical location in the working folder before it can be modified.
- Each user must have a physical location on their disk mapped to the corresponding vault location. A folder that has been mapped to the root folder ("\$") in a vault is called a working folder. Each Vault user can optionally set a local working folder (physical location on disk) for the root of the vault or rely on the default one (C:\My Documents\Vault) provided by Vault. Setting up a working folder creates a user-defined

virtual-to-physical mapping that is maintained for as long as the user works with the vault. The working folder can be changed, but the mapping itself cannot be removed.

- When you check out a project, that project is copied from the virtual location in the vault to the physical location in the working folder. When you are ready to check the project back in, the mapping tells the vault where to check the files in from.
- Opening a project from the vault checks all files out to the working folder of the Vault user. In addition, you can open a checked-in file as read-only.

The essential rules to remember when working with AutoCAD Electrical Vault ARX are:

- The projects in the vault are the masters.
- You can check a project or a single drawing out of the vault to modify it.
- To check out a project for editing, set up a working folder on the disk.

Refer to the Managing Your Data book for more information on AutoCAD Electrical Vault ARX.

## Project manager

Opens or creates a project of one or more drawings, and configures project-wide settings.

 **Ribbon:** Project tab ► Project Tools panel ► Manager. 

 **Toolbar:** Main Electrical 2 

 **Menu:** Projects ► Project ► Project Manager

 **Command entry:** AEPROJECT

Lists the drawing files associated with each open project. Add new drawings, reorder drawing files, and change project settings. Right-click the properties icon for options to move, size, close, dock, hide, or set the transparency for the Project Manager.

You can dock the Project Manager into a specific location on the screen or hide it until you want to use the project tools. Right-click the properties icon

to display options to move, size, close, dock, hide, or set the transparency for the Project Manager.

---

**NOTE** You cannot have two projects open in the Project Manager with the same project name.

---

### Right-click menu

You can right-click in empty space in the Project Manager to display the following options:

<b>New Project</b>	Creates a project. Once created, the new project automatically becomes the active project.
<b>Open Project</b>	Opens a different project from a file selection dialog box. In the Select Project File dialog box, navigate to the project to open and select it.
<b>New Drawing</b>	Creates a drawing file and adds it to the active project. The new drawing displays at the bottom of the project drawing list for the active project.

### Project Selection menu

You can default to a predefined directory by adding an entry to your .env file. Exit AutoCAD and open the .env file with any generic text editor (such as Wordpad). Add this line:

```
WD_PICKPRJDLG, n:/{your directory}/, AutoCAD Electrical default pick proj
```

<b>Recent</b>	Opens a different project from a list of recent projects or from a file selection dialog box.
<b>New Project</b>	Creates a project. Once created, the new project automatically becomes the active project.
<b>Open Project</b>	Opens a different project from a file selection dialog box. In the Select Project File dialog box, navigate to the project to open and select it.
<b>Open Project from Vault</b>	Allows you to browse to the vault to open a project and make it active inside of the Project Manager. You must be logged into the vault. In the Select Project dialog box, navigate to the project to open and select it. Click the arrow

next to the Open button and select one of the following options: Open (Check Out), Open (Check Out All), or Open Read-only.

### Buttons



#### New Project

Creates a project. Once created, the new project automatically becomes the active project.



#### New Drawing

Creates a drawing file and adds it to the active project.



#### Refresh

Refreshes the drawing list inside of the Project Manager.

For Vault: Checks for changes in external file references and updates the Vault icons in the Project Manager. Files that have changed and are currently checked out to you are not updated. Files that are checked out to someone else are updated to their current version. Files that are checked out to someone else are updated to their current version on your local drive. If the Vault version is newer, then the Vault icon indicates that the file needs reloading (the Vault icon turns red).



#### Project Task List

Performs pending updates on any drawing files inside of the active project that have been modified.



#### Project-Wide Update/Re-tag

Updates the related line reference numbers, cross-reference text, device tagging, and signal reference updates on the selected drawing files inside of the active project.



#### Drawing List Display Configuration

Configures the display options. There are ten values that can be associated with the drawings listed so you can display the information based on your requirements.

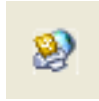

### **Publish/Plot**

Batch plots one or more drawings in the active project.

## **Projects**

Displays all the open projects in a list. You can have as many projects open as you need, but only one project can be active at a time. The active project appears in bold text and is always found at the top of the list. Right-click the project name to display the following project editing options:

<b>Descriptions</b>	Edits the project descriptions. Displays unlimited lines describing the project. Descriptions can then be included in report headers and title blocks.
<b>Title Block Update</b>	Automates updating title block information for the active drawing or for the entire project drawing set.
<b>Drawing List Report</b>	Generates a report that lists project drawing information from the title blocks such as drawing descriptions, section, and file names. On the Drawing List Report dialog box, select to run a new report, redisplay the previously run report or select a format .set file to use for the report.
<b>New Drawing</b>	Creates a drawing file and adds it to the active project.
<b>Add Drawings</b>	Adds one or more drawings to the active project. When prompted, specify whether to apply the project default values to the drawing settings (in the WD_M block definition).
<b>Add Active Drawing</b>	Adds an active drawing to the active project. The new drawing appears at the end of the project drawing list. When prompted, specify whether to apply the project default values to the drawing settings (in the WD_M block definition).
<b>Reorder Drawings</b>	Moves drawings up or down in the drawing list for the project. The order determines how the drawings are processed for project-wide tagging and cross-referencing operations.
<b>Remove Drawings</b>	Removes one or more drawings from the current project. <hr/> <b>NOTE</b> The drawing file is not deleted, just the reference to the drawing. <hr/>

<b>Task List</b>	Performs pending updates on any drawing files inside of the active project that have been modified.
<b>Publish</b>	Launches dialog boxes to plot the project, publish to the Web, publish to DWF, or create a zip file of the project.
<b>Settings</b>	Displays the settings for the project and information about the AutoCAD Electrical environment.
<b>Exception List</b>	Displays a list of drawing files that have different settings from the project definition file (.wdp). If all drawing files match the .wdp, the dialog box indicates that there are no exceptions. You can then use the Settings Compare tool to display the differences.
<b>Properties</b>	Controls project-wide settings including tagging, component cross-referencing options, and catalog lookup file preferences.
<b>Activate</b>	Makes an open project the active project in the AutoCAD Electrical session. This option also sends the project list to the top of the dialog box.
<b>Close</b>	Closes an open project. <hr/> <b>NOTE</b> You cannot close the active project; first activate another project in the list. <hr/>
<b>Vault</b>	You must be logged into the vault to see this menu in the Project Manager. The status of the selected object determines which vault commands are available for selection.  <b>Check In All</b> Adds the project definition file (.wdp) along with its drawing files to the vault. You can vault just the project file using the Project Check In command. You can vault the project file along with its drawing files using the project Check In All command. <hr/> <b>NOTE</b> If files used to support the project (such as .wdl and .wdt) share the same file name as the project, they appear in the Vault Check In All dialog box. <hr/>

<b>Check Out All</b>	Reserves and locks the project definition file along with the associated drawing files listed in the Project Manager. If the project definition file is unavailable for checkout, you can still check out the drawings available for editing.
<b>Check In</b>	<p>Adds the project definition file to the vault and creates a version of the file. Use this option if you want to check in only the project definition file and none of its drawing file dependencies; otherwise use Check In All.</p> <hr/> <p><b>NOTE</b> If files used to support the project (such as .wdl and .wdt) share the same file name as the project, they appear in the Vault Check In dialog box.</p> <hr/>
<b>Check Out</b>	Reserves and locks the master project definition file. Retrieves an updated copy, if necessary. Use this option if you want to check out only the project definition file and none of its drawing file dependencies; otherwise use Check Out All.
<b>Undo Check Out/Undo Check Out All</b>	<p>Removes the reservation/lock from the master project definition file. The master file is now available for others to check out. Any modifications made to the local copy are not checked back into the vault.</p> <p>Undo Check Out All removes the lock from all the checked out drawing files and project definition file listed in the Project Manager for the selected project.</p>
<b>Get Latest/Get Latest All</b>	Retrieves the latest master copy from the vault and copies it into your

working folder. The status indicator displaying a red background indicates older files.

## Project Drawing List

Displays the drawings associated with a project. You can select multiple drawings from the project list to open, close, remove, apply project defaults, or paste properties all at once. You cannot select multiple drawings from two or more projects.

The active drawing appears in bold text in the list. By default, the selected drawing highlights in the project drawing list regardless if the Project Manager is active or not. You can turn off this feature by clicking the Drawing List Display Configuration button and selecting Show selection highlight only when active.



Indicates that the file is a drawing file.



Indicates that a drawing file is a reference drawing. To make a drawing a reference drawing, right-click on the drawing name and select Properties ► Drawing Properties.

Right-click the drawing name to display the following drawing editing options:

- |                |  |
|----------------|--|
| <b>Open</b>    | Opens the selected drawing in a new window. You can also double-click a drawing name or select a drawing name and press Enter to open the drawing.   |
| <b>Close</b>   | Closes the selected drawing.   |
| <b>Copy To</b> | Copies the selected drawing into the same or another open project. Select the folder to copy the drawing to, enter a new file name and select the project to save the drawing to. When prompted, specify whether to apply the project default values to the drawing settings (in the WD_M block definition). |
| <b>Remove</b>  | Removes the selected drawing from the current project.   |
| <b>Replace</b> | Replaces the selected drawing with one that you select from a file selection dialog box.   |



<b>Rename</b>	Renames the selected drawing directly in the drawing list.
<b>Drawing Properties</b>	Assigns, edits, and removes section and subsection coding for a drawing. Assigns drawing descriptions to the drawing files.
<b>Apply Project Defaults</b>	Applies project settings to new drawing files where the project default settings for the drawings were not applied at creation time.
<b>Copy</b>	Copies the drawing settings and options from one drawing to one or more drawings. <hr/> <b>NOTE</b> Drawing-specific information (found on the Drawing Properties ► Drawing Settings tab) cannot be copied from one drawing to another. <hr/>
<b>Paste</b>	Applies the copied drawing settings and options from one drawing to the selected drawings.
<b>Settings Compare</b>	Displays differences between all drawing settings and their associated defaults in the project definition file.
<b>Check In</b>	(you must be logged into the vault) Adds a file to the vault and creates a version of the file. The first time drawing file is checked in, the project definition file is checked in at the same time. The project definition file is vaulted first to establish a location in the Vault database.
<b>Check Out</b>	(you must be logged into the vault) Reserves and locks the master drawing file. Retrieves an updated copy, if necessary. Checks out the drawing files when the project file is under Vault control.
<b>Undo Check Out</b>	(you must be logged into the vault) Removes the reservation/lock from the master drawing file. The master file is now available for others to check out. Any modifications made to the local copy are not checked back into the vault.
<b>Get Latest</b>	(you must be logged into the vault) Retrieves the latest master copy from the vault and copies it into your working folder. The status indicator displaying a red background indicates older files.

---

**NOTE** Two projects can reference the same drawing file. If both projects try to modify the same drawing with a project-wide tagging or cross-referencing function it can lead to conflicts.

---

### Details



Switches between displaying drawing previews and drawing descriptions. The drawing details are updated when you highlight a drawing file and remain visible until a new drawing file is selected. Use the up and down arrow keys on your keyboard to switch drawings.







<b>Details</b>	Displays project and drawing detail based on what is highlighted in the Project pane. Information listed includes the status, file name, file location, file size, last saved date, and the name of the last user who modified the file.
<b>Preview</b>	Displays the last saved thumbnail view for the highlighted drawing in the drawing list.

### Vault Status Icons

(you must be logged into the vault) The Vault Status Icons indicate the status of your local copy of the files as compared against the master copy of those same files in the vault.

The Vault Status indicate when the local copy is in sync with the master and when it is not. The tooltips help guide you to the next logical steps - especially when the local copy is no longer in sync with the master. These icons are crucial to the overall understanding of how to work in a vaulted environment.

<b>Icon</b>	<b>Meaning</b>
	File is not in the vault.
	File is in the vault and available to be checked out. The version in your working folder is the same as in the vault. Also referred to as the Latest Version.
	File is in the vault and available to be checked out, but the local version is newer than the latest version in the vault. This status typically means that your local file was changed without checking it out. If you want to save these changes, check out the file with the Don'tGet Local Copy option.

-  File is in the vault and available to be checked out, but the local copy is out of date. Get the latest version from the vault.
-  File is checked out to you and the local version is the same as in the vault. Also referred to as the Latest Version.
-  File is checked out to you and the local copy is newer than the latest version in the vault. This status typically means that you changed the file since it was checked out but have not checked it back in.
-  File is checked out to you and the local copy is older than the latest version in the vault. This status typically means that you started with a version for the vault that was older than the latest version, and then checked it out to promote it to the latest.
-  File is checked out by someone else, and the local copy is the same as in the vault. Also referred to as the Latest Version. This condition typically occurs if the other person did not check changes back into the vault.
-  File is checked out to someone else, but the local copy is newer than the latest version in the vault. This condition typically occurs if the other person checked changes into the vault, but kept the file checked out. Use Refresh from Vault to update to the latest available version.
-  File is checked out to someone else, but the local copy is older than the latest version in the vault. Use Refresh from Vault to update to the latest available version.

## Create a drawing

### Create a drawing

Use the Project Manager to create a drawing.

- 1 Click Project tab ► Project Tools panel ► Manager. 

- 2  In the Project Manager, click the New Drawing tool.

---







**NOTE** You can also create a drawing by right-clicking at the bottom of the tree inside the Project Manager and selecting New Drawing or by right-clicking on the active project name and selecting New Drawing.

---

- 3 In the Create New Drawing dialog box, enter the name for the new drawing. The .dwg extension is automatically added to the file name.
- 4 Specify the template drawing to use for the creation of the drawing file. If left blank, the default ACAD.DWT file is used. Click Browse to select a template drawing or enter the path and name of a template in the box.
- 5 Select or create the directory where you want to save the drawing.
- 6 (Optional) Enter descriptions for the drawing. You can enter up to three description lines for the drawing file. The description displays in title block updates, custom drawing properties, and drawing list reports. Select from a list of predefined descriptions from the active project by clicking the arrow.
- 7 (Optional) Specify the IEC default values for the project, installation, and location fields.
- 8 (Optional) Specify the sheet and drawing number value for the WD\_M block definition. Additionally, you can specify the values to use for a section or subsection.
- 9 (Optional) Click OK-Properties to define settings and options for your drawing. Changes you make through the Drawing Properties dialog box are saved as attribute values on the invisible WD\_M block of the drawing.
- 10 Click OK.

## Create new drawing

Creates a drawing file to add to the active project.

-  **Ribbon:** Project tab > Project Tools panel > Manager. 
-  **Toolbar:** Main Electrical 2 
-  **Menu:** Projects > Project > Project Manager
-  **Command entry:** AEPROJECT



On the Project Manager, click the New Drawing button.

---

**NOTE** You can also create a drawing by right-clicking at the bottom of the tree inside the Project Manager and selecting New Drawing or by right-clicking on the active project name and selecting New Drawing.

---

### Drawing File

<b>Name</b>	<p>Specifies the file name for the new drawing. Enter a file name to define any of the drawing properties or to create a drawing.</p> <hr/> <p><b>NOTE</b> The .dwg extension is not required in the edit box.</p> <hr/>
<b>Template</b>	<p>Specifies the path and filename for an AutoCAD Electrical template drawing (.dwt) to use for the creation of a new drawing file. If left blank, the default ACAD.DWT file is used. Click Browse to select a template drawing or type in the path and name of a template.</p> <hr/> <p><b>NOTE</b> The previously used drawing template is retained in the dialog box.</p> <hr/>
<b>For Reference Only</b>	<p>Indicates that the drawing should not be included in tagging, cross-referencing, and reporting functions. If selected, the drawing is included in project-wide plotting and title block operations.</p>
<b>Location</b>	<p>Specifies the location for a drawing file. You can override the default location for the drawing file and create additional folders. If left blank, the drawing file is created at the same location as the definition file of the active project. Click Browse to pick a folder where the new drawing is created.</p> <hr/> <p><b>NOTE</b> You cannot have duplicate drawings in the same location.</p> <hr/>
<b>Description 1-3</b>	<p>Specifies up to three lines of description text for the drawing file. The description displays in title block</p>

updates and custom drawing properties. Select from a list of predefined descriptions from the active project by clicking the arrow.

---

**NOTE** Drawing descriptions are disabled when you are modifying the properties of a drawing that is not in a project or if the project file is unavailable for edit.

---

### IEC-Style Designators

Specifies IEC default values for the drawing, such as Project (%P), Installation (%I), and Location (%L) fields. When you insert a component, the %I and %L default values are used if the Installation and/or Location values would normally be blank.

<b>Project Code</b>	Specifies a project code for the drawing settings on all WD_M blocks. This value can be used as the replaceable parameter %P.
<b>Installation Code</b>	Specifies the Installation code for the WD_M block definition. This value can be used as the replaceable parameter %I.
<b>Location Code</b>	Specifies the Location code for the WD_M block definition. This value can be used as the replaceable parameter %L.
<b>Drawing</b>	Displays a list of Installation or Location codes to select from the active drawing.
<b>Project</b>	Displays a list of previously defined Installation or Location codes to select from the active project or from the Default.INST or Default.LOC file.

### Sheet Values

Component, wire, and cross-reference tagging use replaceable parameters in their format. If you reference the sheet number or drawing number in any of your tagging formats, then specify a default drawing-wide value to use.

<b>Sheet</b>	Specifies the sheet number value for the drawing settings. This value can be used as the replaceable parameter %S.
--------------	--

<b>Drawing</b>	Specifies the drawing number value for the drawing settings. This value can be used as the replaceable parameter %D.
<b>Section</b>	Specifies the section value for the drawing file saved in the project definition file (.wdp). This value can be used as the replaceable parameter %A.
<b>Sub-Section</b>	Specifies the subsection value for the drawing file saved in the project definition file (.wdp). This value can be used as the replaceable parameter %B.

### OK-Properties

Creates the drawing file in the specified location before opening the Drawing Properties dialog box where you can define settings and options for your drawing. Changes you make through this dialog box are saved as attribute values on the invisible WD\_M block of the drawing. If your current drawing does not have this required block present when any AutoCAD Electrical schematic command is invoked, AutoCAD Electrical automatically inserts this block at 0,0.

## Change drawing display options

### Change drawing display options

You can use the Drawing List Display Configuration tool to change the way your drawings are listed in the Project Manager. By default drawings are identified by the drawing file name in the Project Drawing List.

- 1 Click Project tab ► Project Tools panel ► Manager. 

- 2  On the Project Manager, click the Drawing List Display Configuration tool.

- 3 Determine which display options to show in the drawing list. Options include:
  - Installation Code (%I)

- Location Code (%L)
  - Section
  - Sub Section
  - Sheet Number (%S)
  - Drawing Number (%D)
  - Drawing Description 1-3
  - File Name
- 4 Select the display option from the Display Options list and click the >> button or add all of the options by clicking the All >> button.  
The display option you selected moves to the Current Display Order list. To rearrange this list, select an option and click Move Up or Move Down. To remove an option from the list, select the option and click the << button.
  - 5 (Optional) Change the character to use between the values in the listing. The default separator value is a dash (-).
  - 6 (Optional) Change the way the selection highlights in the listing depending on whether the Project Manager is active or not. By default the drawing file you select in the drawing list is highlighted at all times; you can select to highlight your selection only when the Project Manager drawing list is active.
  - 7 Click OK.  
The Project Drawing List automatically updates in the Project Manager.

### Drawing List Display Example

In this example, Sheet Number (%S) and Drawing Description 1 were selected as the display options and the separator value is a dash.

#### Drawing List Before

demo01.dwg  
demo02.dwg  
demo03.dwg

#### Drawing List After

1 - Flow and Interconnection diagram, I/O list  
2 - 3-phase motor control, Control circuit  
3 - Power supplies, I/O module feeds

## Drawing list display configuration



Configures the display options. There are ten values that can be associated with a drawing listed. You can display the information based on your requirements.

 **Ribbon:** Project tab ► Project Tools panel ► Manager.



 **Toolbar:** Main Electrical 2



 **Menu:** Projects ► Project ► Project Manager

 **Command entry:** AEPROJECT

On the Project Manager, click the Drawing List Display Configuration tool.



#### Display Options

Lists the values that you can associate to a drawing.

#### Arrow keys

Moves the selected display option into or from the Current Display Order. To add an option to the list, select the display option from the Display Options list and click the >> button or add all of the options by clicking the All >> button. To remove an option from the list, select the option and click the << button.

#### Current Display Order

Lists the values to display in the listing. You must have one entry specified.

#### Separator Value

Specifies which character to use between the values in the listing. Type the character in the input box or use the default (-).

#### Always show selection highlight/Show selection highlight only when active

Changes the way the selection highlights in the listing depending on whether the Project Manager is active or not. By default the drawing file you select in the drawing list is highlighted at all times; you can select to only highlight your selection when the Project Manager drawing list is active.

<b>Move Up</b>	Moves the selected display option up one spot in the Current Display Order list.
<b>Move Down</b>	Moves the selected display option down one spot in the Current Display Order list.

## Overview of project-related files

There are some optional project-related files that AutoCAD Electrical supports. These files provide various functions such as keeping a project consistent, helping update custom title blocks across a project, or providing custom settings for various tools such as the PLC I/O module insertion tool.

Optional AutoCAD Electrical project-related files include:

<b>Catalog lookup</b>	<p>Database for choosing catalog part number assignments. It is also referenced when automatically generating various bill of materials reports.</p> <p>It is an Access-format MDB file that is named &lt;project&gt;_cat.mdb (project-specific version of a catalog lookup file) or DEFAULT_CAT.MDB (default catalog lookup file). If the project-specific .mdb file is used, it needs to be in the same folder where the &lt;project&gt;.wdp file is located. If a project-specific version is not found, then the DEFAULT_CAT.MDB is searched for in the same folder as the active project file, and then in the paths defined in subdirectory search sequence "C" below.</p>
<b>Description defaults</b>	<p>Lists various standard component description selections, accessible by clicking Defaults on the Insert/Edit Component and Panel Layout - Component Insert/Edit dialog boxes. This file can be a family-specific ASCII text file with a .wdd extension (for example, "PB.WDD" for family "PB" push buttons). If the family-specific file is not found, then it searches for a file with the same path and name as the active project with a .wdd extension (&lt;project&gt;.wdd). If neither a family-specific or project-specific file is found, it defaults to searching for a general description file WD_DESC.WDD in the various AutoCAD Electrical search paths and AutoCAD support paths (subdirectory search sequence "A" below). If none are found, it prompts for browsing to a .wdd description file.</p>

When you click Defaults on the Insert/Edit Component or Panel Layout - Component Insert/Edit dialog box the contents of the ASCII text file display in a dialog box where you can select a line of text to use as the description text. The selected text, up to a ";" comment delimiter if any, then displays in the description edit box on the Insert/Edit dialog box. If the selected text has one or more "l" characters, it is interpreted as having line breaks so the 2nd and 3rd description lines fill in as well.

#### **External component**

Component tagging pick list data carried in an external text file, accessed when you click External List on the Insert/Edit dialog box for schematic or panel layouts. The data in this file can be comma-delimited or space-delimited and can be in any order. When accessed, the contents of the file display in a dialog box so you can select a line of data. It is broken down and displays in a dialog box for mapping to various attributes carried by the schematic component or panel footprint symbol being edited. The elements in the selected line of file data can be mapped to the edited schematic or footprint symbol's attributes such as tag, description, location, and catalog part number. This text file can have a .txt, .csv or .wdx extension. If you do not browse to and select a specific file, AutoCAD Electrical searches for a file with the same path and name as the project's .wdp file but with a .wdx extension. On subsequent command invocations, AutoCAD Electrical defaults to the previously selected file name.

#### **Family tag code map**

Overrides the family tag code of the library symbols by mapping the codes to new values. The tag code of a symbol is used in generating the tag-ID of inserted components, like the "PB" of tag-ID "PB101" or the "K" of tag-ID "-K25." The file WD\_FAM.DAT is searched for in the subdirectory search sequence "A" below. This is an ASCII text file in the format of <old>, <new>. For example, the default family tag code for a JIC library pilot light is "LT" and generates tags such as "LT101." To override this tag code and substitute a family code of "LITE" without editing the library symbols, add this line to the wd\_fam.dat: "LT, LITE."

#### **Footprint lookup**

Database for graphical footprint assignments based on the catalog part number assignments.

A file with the same path and name as the project but with a “\_FOOTPRINT\_LOOKUP.MDB” suffix and extension is searched for first. If the file is not found, then the default FOOTPRINT\_LOOKUP.MDB file is searched for in the same directory as the project file and then in the subdirectory search sequence "B" below.

**Schematic lookup**

Database for schematic components inserted from panel footprints.

A file with the same path and name as the project but with a “\_SCHEMATIC\_LOOKUP.MDB” suffix and extension is searched for first. If the file is not found, then the default SCHEMATIC\_LOOKUP.MDB file is searched for in the same directory as the project file and then in the subdirectory search sequence "B" below.

**Installation codes**

Lists the default installation codes for selections found in the Insert/Edit Component and Panel Layout - Component Insert/Edit dialog boxes (select Include external list from the installation's Project list subdialog box).

A file with the same path and name as the project with an .inst extension is searched for first. If the file is not found, then the DEFAULT.INST file is searched for in the same directory as the project file and then in the subdirectory search sequence "A" below.

**Location codes**

Lists the default location codes for selections found in the Insert/Edit Component and Panel Layout - Component Insert/Edit dialog boxes (select Include external list from the location's Project list subdialog box).

A file with the same path and name as the project with a .loc extension is searched for first. If the file is not found, then the DEFAULT.LOC file is searched for in the same directory as the project file and then in the subdirectory search sequence "A" below.

**Group codes**

Lists the default group codes for selections found in the Panel Layout - Component Insert/Edit dialog box (select Include external list from the location's Project list subdialog box).

A file with the same path and name as the project with a .grp extension is searched for first. If the file is not found, then the DEFAULT.GRP file is searched for in the same dir-

ectory as the project file and then in the subdirectory search sequence "A" below.

#### **Mount codes**

Lists the default mount codes for selections found in the Panel Layout - Component Insert/Edit dialog boxes (select Include external list from the location's Project list subdialog box).

A file with the same path and name as the project with a .mnt extension is searched for first. If the file is not found, then the DEFAULT.MNT file is searched for in the same directory as the project file and then in the subdirectory search sequence "A" below.

#### **Project labels**

Customizes the generic LINEx labels in the various title block and project information dialog boxes.

A file with the same path and name as the project with a .wdl extension is searched for first. If the file is not found, then the DEFAULT\_WDTITLE.WDL file is searched for in the same directory as the project file and then in the subdirectory search sequence "A" below.

#### **Rating defaults**

Lists the default rating values found in the Insert/Edit Component and Panel Layout - Component Insert/Edit dialog boxes. The contents of this ASCII text file display in a dialog box. The "|" character can be used to delimit consecutive RATINGx value assignments. For example, picking an entry "30A|60A" would put "30A" into the first RATINGx attribute and "60A" into the RATING(x+1) attribute.

A file with the same path and name as the project but with a .wdr extension is searched for first. If the file is not found, then the default WD\_RATINGS.WDR file is searched for in the subdirectory search sequence "A" below. Alternately, a family-specific file can be accessed (for example, PS.WDR for pressure switches).

#### **Real-time error checking**

The .wdn file is a text file used specifically for auditing. In the .wdn file, terminal numbers are not checked for duplication. You can use wildcards to exclude a range of terminals for duplication checking such as all terminals with a tag name starting with "T" and with terminal number "1." AutoCAD Electrical searches for the <project\_name>.wdn file in the same folder as the project definition file (.wdp).

If <project\_name>.wdn is not found, AutoCAD Electrical looks for the DEFAULT.WDN file in the project folder:

**Windows XP:** C:\Documents and Settings\{username}\My Documents\Acade {version}\AeData\Proj\

**Windows Vista, Windows 7:** C:\Users\{username}\Documents\Acade {version}\AeData\Proj

The default .wdn file contains the terminal number files GND, PE, and E. They are ignored when checking for duplication and are not listed in the Electrical Audit report. Edit this file with an ASCII text editor, such as WordPad.

#### **RSLogix import**

Defines the optional mapping of RSLogix codes to AutoCAD Electrical symbol block names for an RSLogix file import. A file with the same path and name as the project but with a .wdf extension is searched for first. If the file is not found, then the file DEFAULT\_RSLOGIX.WDF file is searched for in the subdirectory search sequence "A" below and, if not found, file \_DEFAULT\_RSLOGIX.WDF is then searched for.

#### **Spreadsheet to PLC tool**

Defines the settings for the AutoCAD Electrical Spreadsheet to PLC I/O Utility. You are prompted to browse to a file with a .wdi extension. The default settings file is DEMOPLC.WDI.

#### **Title block**

The attribute name mapping support file for the AutoCAD Electrical title block update tool. A file with the same path and name as the project but with a .wdt extension is searched for first. If the file is not found, then the DEFAULT.WDT file is searched for in the same directory as the project file. If the file is not found, then the file is searched for in the subdirectory search sequence "A" below.

#### **User defined attributes**

An attribute text file of user-defined attributes defined on AutoCAD Electrical blocks. The User Defined Attribute List is used by report tools to determine which additional attributes are listed in a report. The list file name can be the same as the active project or named Default to be used by the entire system. The DEFAULT.WDA file is saved in the base project folder, while the <project\_name>.wda file is saved in the same folder as the project definition file (.wdp).

### Wire color and gauge labels

Maps color and gauge wire descriptions based on wire layers.

A file with the same path and name as the project but with a .wdw extension is searched for first. If the file is not found, then the DEFAULT.WDW file is searched for in the same directory as the project file. If the file is not found, then the file is searched for in the subdirectory search sequence "A" below.

### Subdirectory search sequence "A"

1 Full path (if full path name given)

2 User subdirectory

**Windows XP:** C:\Documents and Settings\{username}\Application Data\Autodesk\AutoCAD Electrical {version}\{release}\{country code}\Support\User\

**Windows Vista, Windows 7:**

C:\Users\{username}\AppData\Roaming\Autodesk\AutoCAD Electrical {version}\{release}\{country code}\Support\User\

3 Active project's .wdp file subdirectory

4 AutoCAD Electrical support

**Windows XP:** C:\Documents and Settings\{username}\Application Data\Autodesk\AutoCAD Electrical {version}\{release}\{country code}\Support\AeData\

**Windows Vista, Windows 7:**

C:\Users\{username}\AppData\Roaming\Autodesk\AutoCAD Electrical {version}\{release}\{country code}\Support\AeData\

5 AutoCAD Electrical support

**Windows XP:** C:\Documents and Settings\{username}\Application Data\Autodesk\AutoCAD Electrical {version}\{release}\{country code}\Support\

**Windows Vista, Windows 7:**

C:\Users\{username}\AppData\Roaming\Autodesk\AutoCAD Electrical {version}\{release}\{country code}\Support\

6 AutoCAD Electrical support (C:\Program Files [(x86)]\Autodesk\Acade {version}\Support\)

- 7 AutoCAD Electrical support (C:\Program Files [(x86)]\Autodesk\Acade {version}\)
- 8 All paths defined under AutoCAD Options ► Files ► Support Files Search Path

### Subdirectory search sequence "B"

- 1 Full path (if full path name given)
- 2 User subdirectory
  - Windows XP:** C:\Documents and Settings\{username}\Application Data\Autodesk\AutoCAD Electrical {version}\{release}\{country code}\Support\User\
  - Windows Vista, Windows 7:** C:\Users\{username}\AppData\Roaming\Autodesk\AutoCAD Electrical {version}\{release}\{country code}\Support\User\
- 3 Catalog lookup subdirectory
  - Windows XP:** C:\Documents and Settings\{username}\My Documents\Acade {version}\AeData\Catalogs\
  - Windows Vista, Windows 7:** C:\Users\{username}\Documents\Acade {version}\AeData\Catalogs\
- 4 Panel footprint library base subdirectory
  - Windows XP:** C:\Documents and Settings\All Users\Documents\Autodesk\Acade {version}\Libs\panel\
  - Windows Vista, Windows 7:** C:\Users\Public\Documents\Autodesk\Acade {version}\Libs\panel\
- 5 AutoCAD Electrical support
  - Windows XP:** C:\Documents and Settings\{username}\Application Data\Autodesk\AutoCAD Electrical {version}\{release}\{country code}\Support\AeData\
  - Windows Vista, Windows 7:** C:\Users\{username}\AppData\Roaming\Autodesk\AutoCAD Electrical {version}\{release}\{country code}\Support\AeData\
- 6 AutoCAD Electrical support
  - Windows XP:** C:\Documents and Settings\{username}\Application Data\Autodesk\AutoCAD Electrical {version}\{release}\{country code}\Support\



**Windows Vista, Windows 7:**

C:\Users\{username}\AppData\Roaming\Autodesk\AutoCAD Electrical {version}\{release}\{country code}\Support\

- 7 AutoCAD Electrical support (C:\Program Files [(x86)]\Autodesk\Acade {version}\Support\)
- 8 AutoCAD Electrical support (C:\Program Files [(x86)]\Autodesk\Acade {version}\)
- 9 All paths defined under AutoCAD Options ► Files ► Support Files Search Path

**Subdirectory search sequence "C"**

- 1 Full path (if full path name given)
- 2 User subdirectory  
**Windows XP:** C:\Documents and Settings\{username}\Application Data\Autodesk\AutoCAD Electrical {version}\{release}\{country code}\Support\User\  
**Windows Vista, Windows 7:** C:\Users\{username}\AppData\Roaming\Autodesk\AutoCAD Electrical {version}\{release}\{country code}\Support\User\  
3 Catalog lookup subdirectory  
**Windows XP:** C:\Documents and Settings\{username}\My Documents\Acade {version}\AeData\Catalogs\  
**Windows Vista, Windows 7:** C:\Users\{username}\Documents\Acade {version}\AeData\Catalogs\  
4 AutoCAD Electrical support  
**Windows XP:** C:\Documents and Settings\{username}\Application Data\Autodesk\AutoCAD Electrical {version}\{release}\{country code}\Support\AeData\  
**Windows Vista, Windows 7:** C:\Users\{username}\AppData\Roaming\Autodesk\AutoCAD Electrical {version}\{release}\{country code}\Support\AeData\  
5 AutoCAD Electrical support  
**Windows XP:** C:\Documents and Settings\{username}\Application Data\Autodesk\AutoCAD Electrical {version}\{release}\{country code}\Support\

**Windows Vista, Windows 7:**

C:\Users\{username}\AppData\Roaming\Autodesk\AutoCAD Electrical  
{version}\{release}\{country code}\Support\

- 6 AutoCAD Electrical support (C:\Program Files [(x86)]\Autodesk\Acade  
{version}\Support\)
- 7 AutoCAD Electrical support (C:\Program Files [(x86)]\Autodesk\Acade  
{version}\)
- 8 All paths defined under AutoCAD Options ► Files ► Support Files  
Search Path

---

**NOTE** If the environment file (wd.env) has setting WD\_ACADPATHFIRST uncommented and set to 1, then the last search item, the Options paths, are searched between steps 1 and 2 above instead of at the very end.

---

**NOTE** If the environment file (wd.env) has setting WD\_SUP\_ALT uncommented and set to a valid subdirectory path, then it is inserted into the search sequence just after User.

---

## Overview of the project file format

A “.wdp” project file is a text file that lists the drawing files to treat as a multi-drawing wiring diagram. AutoCAD Electrical manages this file automatically. Here is a general breakdown of the .wdp file format:

<b>Project description</b>	All lines of text marked with "[n]" in columns 1-4 followed by the line of project data (n=1 to xxx)
<b>Project default settings</b>	Entries marked with "[n]" in columns 1-4. Many of these values are mirrored on attributes carried by the invisible WD_M block of each drawing. This current project "copy" of the drawing properties settings can migrate to each new AutoCAD Electrical drawing. It overwrites the defaults carried on the WD_M.dwg library symbol as it inserts. The WD_M block alert box displays for permission to insert into a new or non-AutoCAD Electrical drawing. The check box controls the drawing settings: OFF - the settings of the drawing are the defaults carried on the WD_M.dwg library symbol.

ON - the settings of the drawing are set to match the "[n]" settings listed in the .wdp file of the current project.

For example, you have an active project that is set up for a one-of-a-kind wire tagging format that is different from all your other projects. It is also different from the default carried on the WD\_M.dwg block insert of the symbol library. When you start a new drawing for the project, check this switch on. The special settings of your active project update the values on the inserted WD\_M block insert and cause it to match the special settings of the project. It eliminates the need to go back into the properties of a new drawing and adjust the wire tagging format setting to match the project.

<b>Default schematic library path</b>	Marked with "+[1]" in columns 1-4 followed by path or semicolon delimited paths. If multiple paths, the search for a given library symbol file name includes the sequence of the paths listed here in the order given.
<b>Schematic icon menu file</b>	Marked with "+[2]" in columns 1-4 followed by file. It can be a full path or just the icon menu file name itself (such as ACE_JIC_MENU.DAT or ACE_IEC_MENU.DAT).
<b>Default panel library path</b>	Marked with "+[3]" in columns 1-4 followed by base panel library path or semicolon delimited base paths. If multiple paths, the search for a given footprint library symbol includes the sequence of paths listed here in the order given.
<b>Panel icon menu file</b>	Marked with "+[4]" in columns 1-4 followed by file. It can be a full path or just the icon menu file name itself (such as ACE_PANEL_MENU.DAT).
<b>Cross-Reference Options</b>	Marked with "+[5]" followed by 1's bit set = automatic/real-time cross-referencing mode is "on", 2's bit set = peer to peer cross-referencing mode is "on", 4's bit set = Suppress Installation/Location codes when match the drawing defaults mode is "on". 0 or entry omitted = all options are off.
<b>Use MISC_CAT table</b>	Marked with "+[6]" followed by 1=always use MISC_CAT for catalog lookup, 2= use MISC_CAT if component-specific

	table not found, 0 or entry omitted = use component-specific only.
<b>LINEx entries for reports</b>	Marked with "+[9]" followed by comma-delimited list. Gives a list of project properties ➤ description entries that are included as a header for generated reports.
<b>Combined Installation/Location/Tag</b>	Marked with "+[10]" followed by 0= Combined Installation/Location component tag mode is "off", 1= mode is "on", 3= mode is "on" and include Installation/Location as a tag prefix.
<b>DESC case mode</b>	Marked with "+[11]" followed by 0= allow entered DESC1-DESC3 to be upper/lower case, missing or 1= force all entered DESC1-DESC3 values to uppercase.
<b>Wire network mode</b>	Marked with "+[13]" followed by 0 or missing= wire tagging normal mode (wires combined into one wire number assignment), 1=per wire basis mode (each connected wire gets its own wire number assignment).
<b>IEC style Installation/Location tag</b>	Marked with "+[14]" followed by 0 or missing= add prefix to TAG when output to reports, 1=suppress adding the prefix to TAG for reports, 3=suppress Installation/Location tag prefix when match drawing-wide Installation/Location default values for reports. This option is only used when +[10] above is set to 1 or 3.
<b>Auto-fill Installation/Location</b>	Marked with "+[15]" followed by 1= component insert to auto-fill Installation/Location attributes with drawing defaults, 0 or missing= normal mode (do not auto-fill attribute values).
<b>Schematic- ➤ Panel wire format</b>	Marked with "+[16]" for the format that is to deal with wire connection entries when there is no existing terminal pin number text on the panel wiring diagram device footprint, meaning annotation ends up formatted into an Mtext entity, and "+[17]" for format of data written onto target TERMxx/WIRENOxx attributes carried on the panel wiring diagram device footprint.
<b>Auto-hide wire number</b>	Marked with "+[18]" followed by 1= auto-hide a wire number on a wire network when a wire number terminal

is present on the network (so that the same wire number does not display twice on the single wire network), 0= normal mode (do not hide any wire number text).

<b>Wire number offset</b>	Marked with "+[19]" followed by wire number offset value, 0 or blank or missing= normal centering of wire numbers on the wire segment, value= offset from left or upper end of wire segment.
<b>Alternate WD.ENV</b>	Marked with "+[20]" followed by the file name. If this alternative .env file does not exist or cannot be found, the default wd.env file is used.
<b>Wire number by layer</b>	Marked with "+[21]" followed by 0= wire number by layer mode is "off", 1= mode is "on", and "+[22]" holds the layer setup. Format of layer setup is semicolon delimited in repeating groups of four elements per layer definition. <layer name>;<tag format>;<starting wire number>;<suffix list>;...
<b>Alternate catalog lookup</b>	Marked with "+[23]" followed by 0= alternate catalog file not defined, 1=defined and "+[24]" holds the alternate catalog lookup file name.
<b>Exclude wire number range</b>	Marked with "+[27]" followed by the wire number ranges to exclude for sequential wire numbering. (blank or missing= no wire numbers excluded) For example, "100-199,500-699."
<b>Wire number terminal override</b>	Marked with "+[29]" followed by 0= normal wire numbering mode or 1=calculate reference-based wire number based on the location not the first terminal in the wire network (or revert to normal wire numbering mode if no terminal in the network).
<b>Calculation of the "CLEN" column</b>	Marked with "+[30]" and set as a global variable (default is 0.0) to aid in the calculation of the "CLEN" column (calculated wire length) in a from/to report that is able to map schematic wire connections to panel physical layouts. This value is the extra amount to add to each end of a calculated wire segment for connection purposes.
<b>Tag/Wire number order</b>	Marked with "+[31]" and set in the Project Properties dialog box. The value can be blank (no sort order override) or 0-

	7 for the various horizontal/vertical sort orders listed in the dialog box.
<b>Real-time error checking</b>	Marked with "+[32]" followed by 0= real-time error checking mode is "off", 1= mode is "on."
<b>Grid column headers</b>	Marked with "+[33]" to indicate a string of column names used in grid column headers in the Wire Type commands.
<b>Suppress dash</b>	Marked with "+[34]" to suppress the dash (-) if it is the first character of a tag when the Combined installation/location component tag mode is "on." See the [+10} entry.
<b>Panel wire annotation delimiter</b>	Marked with "+[35]" to indicate the delimiter character used to separate multiple panel wire annotation values for the same wire connection.
<b>Item number mode</b>	Marked with "+[36]" followed by 1= item assignments per drawing, 0 or missing= item assignments project wide.
<b>Item assignment</b>	Marked with "+[37]" followed by 1= allow item assignment for each part number, 0 or missing= allow item assignment for component only.
<b>Electrical code standard</b>	<p>Marked with "+[38]" followed by the three character suffix which defines the Electrical Code Standard used by Circuit Builder when searching for a specific table in <a href="#">ace_electrical_standards.mdb</a> on page 2015.</p> <p>Circuit Builder searches for a table using the following sequence:</p> <ol style="list-style-type: none"> <li>1 Tables with the three character Electrical code standard suffix.</li> <li>2 Tables without a suffix.</li> <li>3 Tables with an "NEC" suffix.</li> </ol>
<b>Project drawing list</b>	All remaining entries give the drawing names, and any special assignments or descriptions, that are part of the project. The special assignments or description information precede the drawing name they are assigned to. Each line is prefixed with a code. If special "sec/sub" groupings are defined, then a "=" prefix indicates a "sec" entry for the drawing and a "==" prefix indicates a "sub" entry . If one

to three lines of description are defined, "====" precedes each description listed in order. If a drawing is marked "Ref only", a "====REF" entry precedes it. The drawing name is given last. The drawing name contains the path relative to the location of the WDP file of the project.

---

**NOTE** The following options are no longer valid since they are now drawing settings: Cross-reference fill format (+[7]), Cross-reference text between (+[8]) and Cross-reference order (+[28]). Additionally Project scratch database (+[12]) was replaced by the PDS.

---

## Archive a project

The zip utility creates a zip file of the current project's .wdp file and one or more drawing files it references. The zip file can optionally include a copy of the temporary database file of the project to eliminate the need to rebuild the database when the project is unzipped at a later date.

For the zip utility to function, a zip application must be installed on the system running AutoCAD Electrical.

### Initial Configuration

- 1 Edit the .env file to point to the zip utility.
- 2 Create an entry for the utility labeled WD\_ZIP followed by a comma and then the full path name to the executable zip program. For example, WD\_ZIP;c:\Program Files [(x86)]\winzip\winzip32.exe.

---

**NOTE** All drawings to be included in the zipped file must be closed before running the zip utility.

---

This utility can also be accessed from within some AutoCAD Electrical routines that access and modify multiple drawings.

### Archive a drawing set

- 1 Click Project tab ► Project Tools panel ► Zip. 
- 2 Select the drawings to process and click OK.

- 3 In the AutoCAD Electrical Project Zip dialog box, enter the zip name of the file to create or update.
- 4 Indicate whether to include the project database.
- 5 Click OK.

This utility can also be accessed from within some AutoCAD Electrical routines that access and modify multiple drawings.

## Project zip

Zips the drawing list in the current project with your zipping program.

 **Ribbon:** Project tab ► Project Tools panel ► Zip.

 **Menu:** Projects ► Zip Project

 **Command entry:** AEZIPPROJECT



Select the projects to zip and click OK.

Additionally, the utility can be accessed from within some AutoCAD Electrical routines that access and modify multiple drawings.

Your zip program may generate an error message if the active drawing is one of the drawings to zip.

<b>Enter zip file name to create/update</b>	Lists the name and location for the zip file to create. If you want to update a file, browse to the zip file.
<b>Include project database file</b>	Specifies to include the project database file (.mdb) in the zip file.

## Delete a project

Deleting a project and any of the drawings is permanent and cannot be undone. Select to delete:

- Project definition file, .wdp
- All project drawings
- Specific drawings from a list of project drawings



## Deleting a project

Deletes a project and provides the option to also delete the drawing files in the project.



- 1 Click Project tab ► Project Tools panel ► Delete.
- 2 Find and select the .wdp project definition file.
- 3 Click Open.
- 4 Select from the available options:
  - **Delete “wdp” project list file** - deletes the selected .wdp file.
  - **Delete project’s AutoCAD drawing files** - deletes all files listed in the project definition file unless the List option is used.
  - **List** - select specific drawings to delete from the project drawing list. Only available if the drawing files option is selected.

# Work with Multiple Clients

## Overview of setup for multiple clients

You can set up AutoCAD Electrical to deal with multiple clients, each with its own title block and library requirements. Client-specific drawing borders, title blocks, parts libraries, and part number lookup files can be set up to be automatically selected by AutoCAD Electrical when working on the project of a specific client.

### Client subdirectory structure

Set up a subdirectory structure where each client is assigned their own subdirectory. For example, it might look like the following example:

n:\campbell.nap\  
n:\j-m\  
n:\jeep\_toledo\  
n:\jeep\_toledo\

## Set up title block mapping files for clients

Use the AutoCAD Electrical Title block setup tool to create a default.wdt file for the title block of each client. Store this default.wdt in the base subdirectory of the client. For example:

n:\campbell.nap\default.wdt

One way to do it:

- 1 Use AutoCAD Electrical to create a project in the base subdirectory of the client (for example: n:\campbell.nap\dummy.wdp).
- 2 Open the drawing border drawing or any existing drawing that contains the title block of the client (block with attributes).



- 3 Click Project tab ► Other Tools panel ► Title Block Setup.
- 4 In the Title block link method dialog box, select the middle option listed under "Method 1" -- the DEFAULT.WDT file for any project found in subdirectory n:\campbell.nap.
- 5 Click OK.
- 6 Follow the dialog boxes and pick options to build the default.wdt file.

## Customize labels for title blocks

Several title block-related dialog boxes in AutoCAD Electrical display generic labels like "LINE1", "LINE2", and so on. You can change these labels so that they match up with the actual link to the title block of the client. For example, in the ".wdt" mapping file, you might have linked the AutoCAD Electrical data "LINE10" value to the "DRAWN\_BY" attribute on the title block of the client. What you want to see when AutoCAD Electrical displays a title block-related dialog box is not "LINE10" but "Drawn by."

- 1 Create a file called default\_wdtitle.wdl in the subdirectory of the client where you store the project (.wdp) files. Use any generic text editor, such as Windows Notepad or WordPad.
- 2 Edit the file as necessary.  
The file should contain one line per label in the format LINEx=label. The entries do not have to be in order and line numbers may be skipped.
- 3 Save and exit.

Try updating the Title Block from the Project Manager. Notice all of the updated labels.

## Specify client-specific library symbols

If the client has special symbols or text size settings that are different from the default libraries provided with the AutoCAD Electrical product, create and maintain a client-specific symbol library subdirectory with smart AutoCAD Electrical symbols that have been adjusted to meet that standards of the client. When you start a new project for this client, set the AutoCAD Electrical Symbol Library path to point at the library of the client.

- 1 In the Project Manager, right-click the project name, and select Properties.
- 2 In the Project Properties ► Project Settings dialog box, click the plus sign (+) next to Schematic Libraries. Click Add and enter the path of the library into the edit box. Make it the first or only path listed.  
It causes AutoCAD Electrical to look in the client-specific symbol library first before going to a default AutoCAD Electrical symbol library.
- 3 Click OK.

---

**NOTE** Make sure you also update the Panel Footprint Library path.

---

## Start a project for a client

- 1 Create and save the AutoCAD Electrical project .wdp file to the base subdirectory of the client where the default.wdt and wdttitle.wdl files are stored. Make sure that the new project also points at the symbol library of the client.  
The actual drawings for the project can be stored anywhere but you might want to store them in a "job number" subdirectory under the base client subdirectory. For example, for client "Campbell" you have a new project, 12345. Under the N:\campbell.nap network drive subdirectory, create subdirectory n:\campbell.nap\12345. It is where to save the drawings for that project.
- 2 Create a project and save it to the base subdirectory.  
For example, create project P12345.wdp and save it to n:\campbell.nap\P12345.wdp (along with any other Campbell projects that were already created). They are all grouped in this base subdirectory, but their drawing sets are isolated into unique job number subdirectories).

With the previous setup, anytime you work on a Campbell project (project file ".wdp" stored in the n:\campbell.nap directory), AutoCAD Electrical automatically uses the client-specific title block mapping file (n:\campbell.nap\default.wdt) and the client-specific dialog box label file (n:\campbell.nap\wdtitle.wdl).

## Drawing List Report

### Drawing List Report

Reports the settings of each drawing in the project, and provides the means to edit the report and update the drawing properties with the edited values.

- 1 Click Project tab ► Project Tools panel ► Manager. 
- 2 In the Project Manager, right-click the project name, and select Drawing List Report.
- 3 (Optional) In the Drawing List Report dialog box, click Format and browse to a report format file.
- 4 Click New Report.
- 5 Select the drawings to process.
- 6 Click OK.

The data is displayed in the Report Generator dialog box so you can change the report format, save to a file, and place the report as a table.

## IEC tag mode update

### IEC tag mode update

Updates component tagging based on a change in the IEC tagging mode.

 **Ribbon:** Project tab ► Other Tools panel ►  ► IEC Tag Mode

  
Update. = A+B

 **Menu:** Projects ► IEC Tag Mode - Update

 **Command entry:** AEUPDATEIECTAG

If a change to the IEC component tag mode format is detected, use this tool to freshen the tag format. It makes sure that component tags are displayed per the change.

<b>Freshen tags for</b>	Specifies whether to freshen the entire project, the active drawing only, or selected components in the active drawing.
<b>Freshen parent/child cross-reference annotation</b>	Reruns the cross-reference update.
<b>Remove any leading dash character from component tags</b>	Indicates whether any leading "-" characters for component tags are suppressed (box checked) or added (box unchecked). It is controlled from the Project Properties ► Components dialog box.
<b>Force Installation and Location attributes to be visible or invisible</b>	Switches the visibility of Installation and Location attributes on each component.

## Task list

### Task list

Change the drawing files that were accumulated while drawing files were unavailable for editing.

 **Ribbon:** Project tab ► Project Tools panel ► Manager. 

 **Toolbar:** Main Electrical 2 

 **Menu:** Projects ► Project ► Project Manager

 **Command entry:** AEPROJECT

On the Project Manager, click the Project Task List tool  or right-click the project name and select Task List. On the Update from dialog box, select Update: Select from list of drawings and click OK.

The tasks that still need to be performed on the selected drawings are listed in the upper portion of the dialog box. The login name of the user creating the task, file name, installation and location codes, component tag, type, status, attribute, old value and new value are all displayed. The 'x' indicates that the source of the change no longer matches the task list.

<b>Sort</b>	Sorts the list of tasks to be performed. You can specify four sorts to perform on the list.
<b>Select All</b>	Selects all of the tasks in the list. When you click OK, all of the pending tasks are performed on the selected drawings.
<b>Remove</b>	Removes the selected task from the list.

## Miscellaneous Reference files

### Project database table data -- project drawing files update

#### **Project database table data -- project drawing files update**

AutoCAD Electrical maintains a scratch database for a project, stored in Microsoft Access format that is used to speed up certain project-wide operations. This file is for scratch use only; it is not part of the intelligence stored in an AutoCAD Electrical project. If the scratch database file is missing or corrupted, it is automatically generated from the drawing set of the project. The scratch database file of the project can be used to write back to text data carried on symbols on the drawings. With some care (described in the following section), you can edit the database directly and then import the information back to the drawings.

The file name is <project>.mdb where <project> matches the current project's .wdp file name.

 **Ribbon:** Import/Export Data tab ► Import panel ► From Project MDB.





 **Toolbar:** Schematic Reports

 **Menu:** Projects ► Export to Spreadsheet ► Update from Project Scratch Database

 **Command entry:** AEIMPORTDB

Select the database table to update then select the drawings to process. Any changes are written back to the appropriate objects. Alternately, save the scratch database file with a new name, edit, and then reference this file when the command starts.

#### Cautionary Note

AutoCAD Electrical 2006 and later introduced an automatic scratch database "freshen" function, Project Database Service (PDS), which complicates use of this command over previous versions of AutoCAD Electrical. The PDS automatically updates the scratch project database without your intervention (and without your knowledge). If you edit the scratch database with all of the changes you want to write back to your project set, there is a chance that the PDS comes in, without warning, and remove all of these edits (to match the current state of the unmodified drawings) before you have a chance to run the command to update the drawings.

Even if you are careful not to update the drawings while doing the mdb edit (so that the PDS does not update anything), you can still lose all your edits when you launch the Update from Project Scratch Database command. It is because the command, just before it begins the update, may ask you if it is OK to Qsave the active drawing. If you select OK, then the PDS sees a change and updates the database (for example, erases changes for current drawing), just as the command is getting ready to process.

To prevent it, do not update the drawings while editing the scratch database file and answer "NO" to the Qsave prompt when invoking the actual update command.

## Rebuild database file

### Rebuild database file

Rebuilds or freshens the temporary project database.



 **Toolbar:** Project

 **Menu:** Projects ► Project ► Rebuild/Freshen Project Database

 **Command entry:** AEREBUILDDDB

- **List:** Lists the drawings that appear to be out-of-date with the wire connection table of the project. You can trigger an update when the dialog box is open or you can defer to auto-update when a wire report is run.
- **Include wire connection processing:** Indicates to process wire connections when updating the database file or the wire connection table.
- **Freshen only:** Updates the wire connection table with the out-of-date files.
- **Full rebuild:** Performs a full rebuild of the project database file.

## Select drawings to process

### Select drawings to process

Lists the drawings available to update in the current project.

Select to run any of the project-wide commands.

<b>Do All</b>	Selects all of the drawings from the project drawing list.
<b>Process</b>	Selects one or more drawings from the project drawing list.
<b>Reset</b>	Moves all selected drawings back to the project drawing list.
<b>Un-select</b>	Moves one or more drawings back to the project drawing list.
<b>by Section/subsection</b>	Selects drawings by user-defined sections and subsections.

## Files unavailable for processing

### Files unavailable for processing



If some of the drawings selected for processing are unavailable (such as in a read-only state) this dialog box appears. The file name, status, and location of the drawing is listed in the dialog box for review.

<b>Retry Now</b>	Tries to gain full write access to the entire list of drawing files previously selected. If you gain full access, the files are locked out by you and other users cannot modify until the project-wide command finishes.
<b>Task</b>	Task (saves) all modifications in a task list to run at a later time. The task list is maintained inside of the Project Task List database file (project_update.mdb). Not all commands can write to the task list. See the following list of commands that can be tasked.
<b>Cancel</b>	Cancels the update and returns to the Select Drawings to Process dialog box. Select other files to update or try to gain write access to the entire list of drawings to process.
<b>Ignore</b>	Processes the command on the drawings that are available for editing. Changes to unavailable drawings are not saved to the task list for later updates.

#### **Commands that write to the project\_update.mdb file**

- Edit Component
- Retag Component
- Insert or copy a circuit
- Edit Location box
- Find/Edit/Replace
- Set/Edit Wire Connection Sequence
- Changing an IEC setting before running a Retag
- Copy Location/Installation/Mount/Group
- Copy BOM
- Block Swap
- Terminal Strip Editor
- Insert Schematic from Panel



# Drawing and Project Properties

# 4

## Overview of project and drawing properties

Use the Project Properties dialog box to define settings when creating a project. Then have the settings used for new drawings or the settings added to the project. In the Project Properties dialog box, icons indicate whether the settings apply to project settings or drawing defaults.



Settings that apply to project settings and are saved inside the project definition file (.wdp).



Settings that are saved in the project file as drawing defaults. Drawing related data to add to the project when running the Add Drawing command is saved as Drawing Custom Properties.

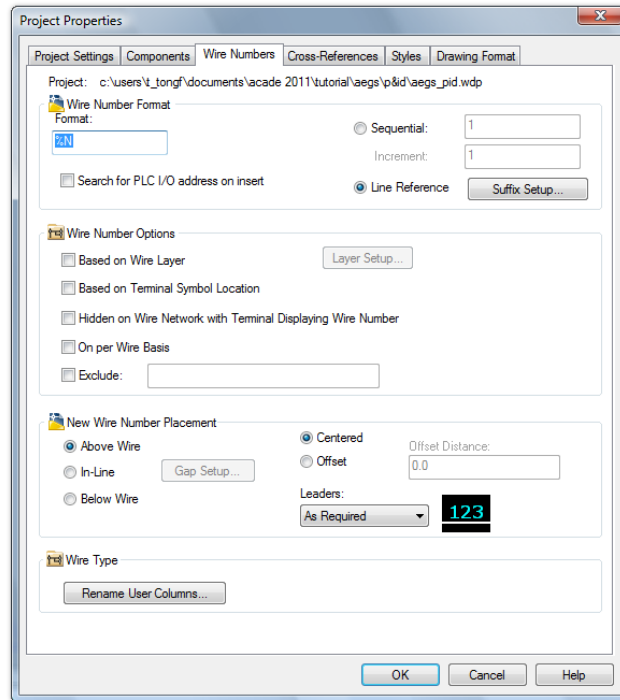

Use the Drawing Properties dialog box to define settings for a new or selected drawing. These settings override the project properties set in the Project Properties dialog box. If the drawing is part of a project, the project name displays in the dialog box. Otherwise, text displays indicating that the drawing is not part of a project, and drawing-related edit fields saved in the .wdp file are disabled.

You can specify settings for the project or drawing defaults, components, wire numbers, cross-references, styles, and the drawing format using either the Project Properties or Drawing Properties dialog boxes. An overview of the available options for each tab are listed in the following section.

### Settings

Project settings include:

- Library and Icon Menu paths
- Catalog lookup file preferences
- Real-time error checking options

Drawing settings include:

- Drawing type and descriptions
- IEC default values for the Project (%P), Installation (%I), and Location (%L) fields
- Sheet values for the sheet and drawing in addition to section or subsection codes

### **Components**

Use this tab to:

- Specify the way new component tags are created.
- Switch between sequential or line reference based tags.
- Set component tag options such as using combined Installation/Location tags or suppressing the Installation/Location tag on reports.
- Display description text in uppercase.

### **Wire Numbers**

Use this tab to:

- Set the wire number format.
- Switch between sequential or line reference based wire numbers.
- Set wire number options such as hidden numbers, excluded numbers, or displaying numbers on a per wire basis.
- Set up wire number layer options.
- Define wire number placement: above, below, or in-line.
- Define wire number leaders.

### **Cross-references**

Use this tab to:

- Define the cross-reference annotation format.
- Set cross-reference options such as suppressing Installation/Location codes or using real-time signal and contact cross-referencing between drawings.

- Set component cross-reference display: text, graphical, or table. You can also change the display format setup from this dialog box.

### Styles

Use this tab to:

- Change default styles for arrows, plcs, fan-in/out markers, and wiring.
- Add or remove layers from the layer list.

### Drawing Format

Use this tab to:

- Set the default orientation, spacing, and width values for any new ladders inserted on the drawing.
- Specify the format referencing style: X-Y Grid, X Zones, or Reference Numbers.
- Set the scale factor used when inserting new components or wire numbers on the drawing.
- Set the tag/wire number sort order.
- Define and manage wire and component layers.

## Set project or drawing properties

You can specify settings for the project or drawing defaults, components, wire numbers, cross-references, styles, and the drawing format using either the Project Properties or Drawing Properties dialog boxes. The following steps are for setting project properties. To set drawing properties, open the Project Manager, then right-click the drawing name and select Properties ► Drawing Properties, or click the Drawing Properties tool.



- 1 Click Project tab ► Project Tools panel ► Manager.
- 2 In the Project Manager, right-click the project name, and select Properties.

---

**NOTE** You can also set project properties when you create a project. Create the project and click OK -Properties in the Create New Project dialog box.

---

- 3 In the Project Properties dialog box, select the tab to modify properties for.
- 4 Click OK.

## Set project descriptions

You can specify descriptions for use in reports and title block updates. AutoCAD Electrical supports an unlimited number of description lines.

- 1 Click Project tab ► Project Tools panel ► Manager. 
- 2 In the Project Manager, right-click the project name, and select Descriptions.

---

**NOTE** You can also set project descriptions when you create a project. Create the project and click Descriptions in the Create New Project dialog box.

---

- 3 In the Project Description dialog box, enter values for each line. The dialog box displays 12 description lines at one time.



Displays the first 12 description lines.



Displays the previous 12 description lines.



Displays the next 12 description lines.



Displays the last set of 12 description lines, where one of the lines has a value.

- 4 Select the **in reports** check box to include the description line in a report when the Project Lines Header is added.
- 5 Click OK.

## See also:

- [Customize LINEx Labels](#) on page 1224
- [Map AutoLISP values to the title block](#) on page 1226

## Project properties: project settings tab

Modify your project default settings for libraries, catalog lookup, and error checking. All information defined in this tab is saved to the project definition file as a project default.

 **Ribbon:** Project tab > Project Tools panel > Manager. 

 **Toolbar:** Main Electrical 2 

 **Menu:** Projects > Project > Project Manager

 **Command entry:** AEPROJECT

In the Project Manager, right-click the project name, and select Properties. Select the Project Settings tab.

### Library and Icon Menu Paths

Select which schematic library, panel library, and icon menus to use.

#### Libraries

To modify existing input fields in the tree structure, double-click the folder (for example, Schematic Libraries) and highlight the path to change. Then browse to the path of the schematic or base footprint symbol library to use for the project. You can also include a series of paths for AutoCAD Electrical to search in order. You can include electrical, pneumatic, or other schematic libraries in the path.

---

**NOTE** The symbol search path includes the User and Project folders (and potentially the AutoCAD search paths) before the paths listed here. In the Project Manager, right-click the project name, and select Settings to view the active search path for the project.

---

#### Icon Menu File

To use an icon menu for the project that is different from the default, enter the file name. This menu reference is saved in the project's .wdp file.



---

**NOTE** You can only specify one search path for the icon menu.

---

<b>Add</b>	Adds a new entry into the libraries tree structure.
<b>Browse</b>	Browses for a folder to select a symbol library or icon menu from.
<b>Remove</b>	Removes the selected path from the libraries tree structure.
<b>Move Up</b>	Moves the selected path up one spot in the libraries tree structure.
<b>Move Down</b>	Moves the selected path down one spot in the libraries tree structure.
<b>Default</b>	Brings the default paths from the environment file (WD.ENV) into the list box tree view for all search paths found underneath the highlighted folder.

### Catalog Lookup File Preference

<b>Use component-specific tables</b>	Searches for the component name as the catalog table. If the component table is not found, the family name table is searched. If neither table is found, use the Catalog Lookup File dialog box to create a component or family table or select a different table.
<b>Other File</b>	Defines a secondary catalog lookup file.
<b>Always use MISC_CAT table</b>	Searches only the MISC_CAT table. You can search other component tables if the catalog number is not found in the MISC_CAT table.
<b>Use MISC_CAT table only if component-specific table does not exist</b>	Uses the MISC_CAT table if the component or family tables are not found in the catalog database.

### Options

<b>Real-time error checking</b>	Performs real-time error checking on the project to determine if duplications of wire numbers or component tags occur in the project. An error log file is created for every project regardless whether you chose to display the real-time warning dialog box or not. The real-time warning is saved in
---------------------------------	--

the log file named "<project\_name>\_error.log" and is saved in the User subdirectory. If a log file exists, the new content is added to the same file. A blank line separates one error record from another.

**Tag/Wire Number Sort Order**

Sets the default wire numbering and component tag sort order for the project.

**Electrical Code Standard**

Sets the Electrical code standard used by Circuit Builder. A three character suffix code is saved to the.wdp project file. The suffix is used when searching for a specific table in [ace\\_electrical\\_standards.mdb](#) on page 2015.

Circuit Builder searches for a table using the following sequence:

- 1 Tables with the three character Electrical Code Standard suffix.
- 2 Tables without a suffix.
- 3 Tables with an "NEC" suffix.

## Catalog lookup file

It defines a secondary catalog lookup file to use.

 **Ribbon:** Project tab ► Project Tools panel ► Manager. 

 **Toolbar:** Main Electrical 2 

 **Menu:** Projects ► Project ► Project Manager

 **Command entry:** AEPROJECT

On the Project Manager, right-click on the Project name and select Properties.

In the Project Properties ► Project Settings dialog box, Catalog Lookup File Preference section, click Other File.

**Single catalog lookup file**

Specifies to use only one catalog lookup file. The file that is used depends on what was selected on the Project Properties ► Project Settings dialog box.

**Optional: Define a secondary catalog lookup file for this project**

Specifies to define a secondary lookup file for the project. Catalog lookup files provided with AutoCAD Electrical include: default\_cat.mdb, footprint\_lookup.mdb, schematic\_lookup.mdb, wd\_lang1.mdb, and wd\_picklist.mdb.

Defines a secondary catalog lookup file that functions as such:

- For catalog part number selection, switches to a secondary catalog lookup file.
- For BOM report generation, queries the secondary catalog lookup file when the target part number is not found in the default file.

## Project properties: components tab

Modify your project default settings for components. All information defined in this tab is saved to the project definition file as project defaults and settings.

 **Ribbon:** Project tab > Project Tools panel > Manager. 

 **Toolbar:** Main Electrical 2 

 **Menu:** Projects > Project > Project Manager

 **Command entry:** AEPROJECT

In the Project Manager, right-click the project name, and select Properties. Select the Components tab.

### Component TAG Format

**Tag Format**

Specifies the way new component tags are created. The tag consists of a minimum of two pieces of information: a family code and an alphanumeric reference number (for example, "CR" and "100" to yield a tag like CR100 or 100CR). Optionally, a component tag might contain a sheet number or some user-specified separators. If your format includes the sheet number %S parameter or the drawing number %D parameter, enter the values in the edit boxes in the Drawing Properties > Drawing Settings dialog box.

	<p><b>NOTE</b> AutoCAD Electrical provides a predefined format for you to use or you can enter your own format using <a href="#">replaceable parameters</a> on page 236.</p>
	<p><b>NOTE</b> The %N parameter is mandatory in any component tag format you define.</p>
<b>Search for PLC I/O address on insert</b>	<p>Searches for a connected PLC I/O module's I/O point. If found, the I/O address value is substituted for the "%N" part of the default component tag.</p> <p><b>NOTE</b> This setting is saved in the MISC_FLAGS attribute on the WD_M block of the drawing.</p>
<b>Sequential</b>	<p>Enter the beginning sequential number for the drawing. Sequential tags can continue uninterrupted from one drawing to the next if you assign the same beginning sequential number to every drawing in your project. As you insert components on any drawing of the project set, AutoCAD Electrical starts with the value you set and works its way up until it finds the next unused sequential number tag for the target component family.</p> <p><b>NOTE</b> If you finish a drawing and move to the next, but return to the first drawing to add another component and sequential tag, a gap appears in the numbering sequence for that drawing. Use the AutoCAD Electrical Project-wide Update/Retag tool to retag the whole drawing set.</p>
<b>Line Reference</b>	<p>Set up the unique format tag suffix list. Use this list to create unique reference-based tags when multiple components of the same family are located at the same reference location. (For example, three push buttons on the same line reference "101" could be labeled PB101, PB101A, and PB101B -- AutoCAD Electrical does this using a suffix list of " ", "A", "B", and so on).</p>

---

**NOTE** The component tag suffix is automatically added to the end of the tag. You can force AutoCAD Electrical to insert the suffix character somewhere within the tag format. Use the Suffix position parameter, %X, in the component tag format (for example, %N%X - %F).

---

### Suffix Setup

Displays the suffix list. The individual items in the suffix list are given in the row of edit boxes across the top of the dialog box. List suffix characters for duplicate family components on the same line reference or in the same zone (to keep tags unique). The suffix is added to the end of the component tag. To add it to the inside of the tag, use "%X" in the Tag Format. Example:

%N-%F or %N-%F%X = suffix at the end (such as 101-CRA)

%N%X-%F = add to number, before family code (such as 101A-CR)

Select from the default lists or manually enter your own suffix list in the row of edit boxes.

## Component TAG Options

**Combined Installation/Location tag mode** Uses the combined installation/location tag for interpreting component tag names. For example, -100CR relay contact marked with location code PNL1 is interpreted as being associated with a different relay coil than relay contact -100CR marked with location code PNL2. If this setting is not selected, both contacts are associated with the same parent relay coil, -100CR.

**Suppress dash when first character of tag** Suppresses any single-dash character prefix in an IEC tag that does not have a leading Installation/Location prefix. (For example, "-K101" dash is suppressed to "K101" but "+LOC1-K101" remains unchanged.) When switched OFF, it automatically adds a single dash character to an IEC tag that does not already have a single leading dash prefix. It also does not have a leading Installation/Location prefix. (For ex-

ample, tag "K101" becomes "-K101" but "+LOC1-K101" remains unchanged.

---

**NOTE** This suppression takes place automatically in reports; and takes place graphically only when a component is inserted, edited, or retagged.

---

<b>Format Installation/Location into tag</b>	Specifies to exclude the Installation and Location code values as part of the tag when displaying. For example, if it is not on, a tag might show up as K16 in the Surf dialog box, but if selected the tag might show up +AAA-K16 (where AAA is the location).
<b>Suppress Installation/Location in tag when match drawing default</b>	Suppresses Location and Installation values on components if they match the drawing default values. <hr/> <b>NOTE</b> Update cross-reference text using the Auto-CAD Electrical Cross-reference command.
<b>Suppress Installation/Location in tag on reports</b>	Specifies to exclude Installation and Location values as part of the tag when displayed in reports.
<b>Upon insert: automatic fill Installation/Location with drawing default or last used</b>	Fills the Installation and Location edit boxes on the Insert/Edit component dialog box. The attributes on the block with drawing default or last used values (if no drawing default). If not selected, these edit boxes and attributes are not filled in and are assumed.

---

**NOTE** Avoid using a mixture of drawings in the project when using the Combine Installation/Location Tag mode. For example, do not include some drawings with drawing-wide Installation or Location values and some without drawing-wide values. It can result in a disruption of the child and parent component relationship under certain circumstances.

---

### Component Options

<b>Description text upper case</b>	Forces description text to upper case.
<b>Item Numbering</b>	Launches the Item Numbering Setup dialog box. The dialog box contains options for project or drawing wide item numbering, and per-part number or per-component item numbering.

## Item Numbering Setup

Define the item numbering settings for the project.

 **Ribbon:** Project tab ► Project Tools panel ► Manager. 

 **Toolbar:** Main Electrical 2 

 **Menu:** Projects ► Project ► Project Manager

 **Command entry:** AEPROJECT

In the Project Manager, right-click the project name, and select Properties. Select the Components tab and click Item Numbering.

### Item Numbering Mode

Sets item numbering to either project-wide or per-drawing. This setting controls an Item Resequencing and the “Next>>” buttons on any “Insert/Edit” dialog boxes.

### Item Assignments

**Per-Component Basis** - allow item number assignment to the main catalog part number only.

**Per-Part Number Basis** - allow item number assignment for each catalog entry on a component. It includes the main catalog part number and any multiple catalog part numbers.



---

**NOTE** Item numbers cannot be assigned to part numbers based on ASSYCODE combinations.

---

## Project properties: wire numbers tab

Modify your project default settings for wire numbers. All information defined in this tab is saved to the project definition file as project defaults and settings

 **Ribbon:** Project tab ► Project Tools panel ► Manager. 

 **Toolbar:** Main Electrical 2 

 **Menu:** Projects ► Project ► Project Manager

 **Command entry:** AEPROJECT

In the Project Manager, right-click on the project name and select Properties. Select the Wire Numbers tab.

### Wire Number Format

Wire number tags can be sequential or reference-based.

#### Format

Specifies the way new wire number tags are created. The wire number tag format must include the %N parameter that is the base sequential or reference-based value from the selection described. If your format includes the sheet number %S parameter or the drawing number %D parameter, enter the values in the edit boxes in the Drawing Properties ► Drawing Settings dialog box.

---

**NOTE** For reference-based wire number tagging, individual items in the suffix list are applied to the wire tags to keep multiple wires in the same reference location unique. These items are added to the end of the tag, but you can force AutoCAD Electrical to insert the suffix character somewhere within the tag format. Use the Suffix position parameter, %X, in the component tag format (for example, %X%N).

---

**NOTE** AutoCAD Electrical provides a predefined format for you to use or you can enter your own format using [replaceable parameters](#) on page 236.

---

#### Search for PLC I/O address on insert

Specifies to use PLC I/O address values for wires that connect to an addressed I/O point. This setting overrides both Sequential and Reference-based tagging. New wires or wire renumbering on the current drawing show PLC I/O address-based wire numbers automatically.

---

**NOTE** Like component tags, AutoCAD Electrical uses the concept of a wire tag format string with replaceable parameters. The %N parameter must always be part of the wire format string. A typical format string can be just this %N parameter.

---

#### Sequential

Enter the starting sequential number (alpha, numeric, or alphanumeric) for the drawing. If you enter the same starting sequential number for every drawing of your wiring diagram set, AutoCAD Electrical confirms at insertion time that a new sequential wire number tag is not repeated on any other drawing.



If you set DEMO1 to 100 and DEMO2 to 200, the wire numbers on DEMO1 start at 100 and wire numbers on DEMO2 start at 200. If DEMO1 has more than 100 wire numbers it starts using wire number 200 and above. DEMO2 would begin its wire numbers where DEMO1 left off (making sure that duplicate wire numbers are not assigned).

<b>Increment</b>	The default is "1". Setting it to "2" with a starting sequential of "1" would yield wire numbers 1, 3, 5, 7, 9, 11, and so on.
<b>Line Reference</b>	Sets the wire number tag suffix. This list is used to create unique reference-based wire number tags for multiple wire networks. It begins at the same reference location (such as wire network beginning at a location per line reference number, X-Y grid reference, or X-Zone reference).
<b>Suffix Setup</b>	Displays a suffix list. List suffix characters for wire numbers beginning on the same line reference or in the same zone (to keep wire numbers unique). Select one of the four predefined suffix lists or enter your own custom suffix list.

### **Wire Number Options**

<b>Based on Wire Layer</b>	Assigns a different wire number format based on the wire layer.
<b>Layer Setup</b>	Overrides the default wire number format by using layer defined formats. Change the wire layer name, wire number format, starting wire sequence, and wire number suffix.
<b>Based on Terminal Symbol Location</b>	Specifies to use a wire number terminal on a wire network as the line reference value for calculating a reference-based wire number. For example, a wire network starts at line reference 100 and drops down and over on line reference 103. If a schematic terminal symbol carries the WIRENO attribute located on line reference 103, and this option is enabled, AutoCAD Electrical calculates a reference-based wire number using 103 instead of 100. If multiple wire number terminals exist on this network, the line reference value of the upper left-most terminal is used.

<b>Hidden on Wire Network with Terminal Displaying Wire Number</b>	Specifies to hide the wire number automatically for a wire network that has a wire number-type terminal.
<b>On per Wire Basis</b>	Specifies to assign a wire number for each wire rather than the default one wire number per wire network.
<b>Exclude</b>	If using sequential wire numbers, specifies the wire number ranges to exclude. (applied to the %N part of the wire number tag format) Syntax is <starting>-<ending> to show range (for example 1000-1499). Multiple ranges are allowed and must be separated with a comma or semi-colon (for example, 1000-1099;2500-2599;). You can also use 2;4;6 or 2,4,6 for values not in a range.

### **New Wire Number Placement**

---

**NOTE** The Insert Wire Number tool does not take the current wire number setting (in-line, above or below) into account when updating existing wire numbers. This setting is used only when inserting new wire numbers. Use the Toggle Wire Number In-Line tool for flipping existing wire numbers among the three modes.

---

<b>Above Wire</b>	Places the wire number above the physical wire.
<b>In-Line</b>	Places the wire number in line with the wire.
<b>Gap Setup</b>	Defines spacing between the wire number and the wire itself.
<b>Below Wire</b>	Places the wire number below the physical wire.
<b>Centered</b>	Specifies to insert the wire number tags in the center of each wire segment.
<b>Offset</b>	Specifies to insert the wire number tags the specified offset distance.
<b>Offset Distance</b>	Specifies a fixed, user-defined offset distance from the left or top of the first wire segment found on the wire network.
<b>Leaders</b>	(This option is unavailable for in-line wire numbers) AutoCAD Electrical places wire numbers on leaders when it determines that the wire number text bumps into something (it does not check

if the leader itself overlays another object). Select the method for inserting new wire numbers as leaders: As Required, Always, or Never.

---

**NOTE** This change does not affect wire numbers that are already present on the drawing.

---

### Wire Type

Displays the Rename User Columns dialog box used for renaming User1 to User20 header columns in the Set Wire Type, Create/Edit Wire Type, and Change/Convert Wire Type dialog boxes.

### Project properties: cross-references tab

Modify your project default settings for cross-referencing. Any new drawing files created within the project are saved with the project default settings for cross-referencing.

 **Ribbon:** Project tab ► Project Tools panel ► Manager. 

 **Toolbar:** Main Electrical 2 

 **Menu:** Projects ► Project ► Project Manager

 **Command entry:** AEPROJECT

In the Project Manager, right-click the project name, and select Properties. Select the Cross-References tab.

### Cross-reference Format

Defines the cross-reference annotation format. One replaceable parameter, %N, must always be part of the cross-reference format string. A typical format string might be the %N parameter. Use Same Drawing for on-drawing references and Between Drawings for off-drawing references. You can use the same format for both.

---

**NOTE** AutoCAD Electrical provides some predefined formats for you to use or you can enter your own format using [replaceable parameters](#) on page 236.

---

## Cross-reference Options

<b>Real-time signal and contact cross-referencing between drawings</b>	Automatically updates relay and wire source and destination symbols cross-referencing across multiple drawings. <hr/> <b>NOTE</b> If this option is not selected, you are prompted to authorize the update. The target drawing is automatically opened and updated. You then return to the active drawing. Any unauthorized update is queued up in a Project Task List. To update the pending updates, click Project Task List on the Project Manager. <hr/>
<b>Peer to Peer</b>	Cross-references related components while using pneumatic features. Example: schematic - ► pneumatic.
<b>Suppress Installation/Location codes when matching the drawing defaults</b>	Suppresses IEC prefixes. <hr/> <b>NOTE</b> Run the Component Cross-reference command to update any existing cross-referencing text. <hr/>

## Component Cross-reference Display

There are different styles of cross referencing AutoCAD Electrical supports:

<b>Text Format</b>	Displays cross-referencing as text with any string as a separator between references on the same attribute.
<b>Graphical Format</b>	Displays cross-referencing using the AutoCAD Electrical graphical font or using contact mapping edit boxes while displaying each reference on a new line.
<b>Table Format</b>	Displays cross-referencing in a table object, that automatically gets updated in real time, so you can define the columns to display.
<b>Setup</b>	Displays a dialog box for setting the display defaults for each component cross-reference display format.

## Project properties: styles tab

Modify your project default settings for various component styles. All information defined in this tab is saved to the project definition file as project defaults and settings.

 **Ribbon:** Project tab ► Project Tools panel ► Manager.



 **Toolbar:** Main Electrical 2



 **Menu:** Projects ► Project ► Project Manager

 **Command entry:** AEPROJECT







In the Project Manager, right-click on the project name and select Properties. Select the Styles tab.

<b>Arrow Style</b>	<p>Specifies the default wire signal arrow style. Select from the four predefined styles or a user-defined style. You can override the default style setting at insertion time.</p> <hr/> <p><b>TIP</b> For instructions on how to add custom wire arrow styles, see <a href="#">Add custom signal arrow styles</a> on page 1011.</p>
<b>PLC Style</b>	<p>Specifies the default PLC module style. Select from the five predefined styles or a user-defined style.</p> <hr/> <p><b>TIP</b> For instructions on how to add custom PLC module styles, see <a href="#">Add a new PLC style</a> on page 624.</p>
<b>Fan-In/Out Marker Style</b>	<p>Defines the default Fan In/Out marker style and the layers for wires going out of a Fan In/Out Source marker and those coming into a Destination marker.</p> <hr/> <p><b>TIP</b> For instructions on how to add custom Fan-In/Out marker styles, see <a href="#">Add custom fan-in/out marker styles</a> on page 1023.</p>
<b>Layer List</b>	<p>Lists the Fan In/Out layers.</p>
<b>Add</b>	<p>Defines layer names as Fan In/Out layers.</p>
<b>Remove</b>	<p>Removes the selected layer from the defined layer list.</p>

<b>Wire Cross</b>	Specifies the default mode of operation when wires cross each other: insert gap with no loop, insert gap and loop, or solid (no gap).
<b>Wire Tee</b>	Specifies the default wire tee marker: none, dot, angle1, or angle2.

## Project properties: drawing format tab

Allows you to modify your project default settings for drawings. All information defined in this tab is saved to the project definition file as a project default.

-  **Ribbon:** Project tab > Project Tools panel > Manager. 
-  **Toolbar:** Main Electrical 2 
-  **Menu:** Projects > Project > Project Manager
-  **Command entry:** AEPROJECT

In the Project Manager, right-click on the project name and select Properties. Select the Drawing Format tab.

### Ladder Defaults

<b>Vertical/Horizontal</b>	Specifies whether to create ladders horizontally or vertically.
<b>Spacing</b>	Specifies the spacing between each rung.
<b>Default: insert new ladders without references</b>	Sets the default for the Insert Ladder command. New ladders you insert do not have line reference numbering, by default.
<b>Width</b>	Specifies the width of the ladder.
<b>Multi-wire Spacing</b>	Specifies the spacing between each rung in multi-wire phases.

## Format Referencing

Specifies the default referencing system. There are three modes:

<b>X-Y Grid</b>	<p>All referencing is tied to an X-Y grid system of numbers and letters along the left-hand side and top of the drawing. Set the vertical and horizontal index numbers and letters of your drawing, spacing, and origin in the X-Y grid setup dialog box.</p> <hr/> <p><b>TIP</b> Use negative spacing values for Horizontal or Vertical to change the origin of the X-Y grid system to be other than the upper left-hand corner of the drawing.</p> <hr/>
<b>X Zones</b>	<p>Like X-Y Grid, but there is not a Y-axis. Set the horizontal labels, spacing, and origin on the X Zones setup dialog box.</p> <hr/> <p><b>TIP</b> Use a negative zone spacing value if you want the zone reference origin to be at the right side of the drawing.</p> <hr/>
<b>Reference Numbers</b>	<p>Each ladder column has a column of assigned reference numbers.</p>
<b>Setup</b>	<p>Specifies how to display reference numbers -number only, numbers in a hexagon, the sheet and number values, and so on.</p>

## Scale

<b>Feature Scale Multiplier</b>	<p>Sets the scale factor used when inserting new components or wire numbers on the drawing. To insert everything 25% bigger than normal, change the edit box value from 1.00 to 1.25. This change does not affect components and wire numbers that are already present on the drawing.</p>
<b>inch/inch scaled to mm/mm full size</b>	<p>Select inch if your drawing is to use library symbols from the JIC1/JIC125 libraries or mm full size for the metric scaled symbol libraries. It adjusts the wire connection trap distance that determines whether closely spaced wire ends connector not.</p>

## Tag/Wire Number Order

Sets the default wire numbering and component tag sort order for the drawing. Your selection overrides the project settings for sort order unless you select No override.

## Layers

Defines and manages wire and component layers.

---



**NOTE** No matter which layer is current, wires always go to a wire layer and components to component layers.

---

## Drawing properties: drawing settings tab

Sets default values for a drawing.

### Any drawing

 **Ribbon:** Project tab ► Project Tools panel ► Manager. 

 **Toolbar:** Main Electrical 2 

 **Menu:** Projects ► Project Manager

 **Command entry:** AEPROJECT

In the Project Manager, right-click the drawing name, and select Properties ► Drawing Properties. Select the Drawing Settings tab.

### Active drawing

 **Ribbon:** Schematic tab ► Other Tools panel ► Drawing Properties

drop-down ► Drawing Properties. 

 **Toolbar:** Main Electrical 2 

 **Menu:** Projects ► Drawing Properties

 **Command entry:** AEPROPERTIES

Select the Drawing Settings tab.

Sets the values you enter for drawing description, project, installation, location, sheet, and drawing code. Sets the format for component tags, wire numbers, cross-references, PLC modules, signal arrows, ladders, and layers. Overrides the project properties set in the project Properties dialog box.



## Drawing File

<b>Project</b>	<p>Specifies the project that the drawing is found in.</p> <hr/> <p><b>NOTE</b> If the drawing is not in any of the currently open projects, "Drawing not in open project" displays instead of the project name. If the drawing is in an open project but it cannot be edited, "Project not available for edit" displays instead of the project name. This alert displays when a project file is read only, locked by someone else, not checked out in Vault, or the folder where the project is located is read only. When the project is not open or available for edit, you are unable to assign a description for the drawing.</p> <hr/>
<b>Description 1-3</b>	<p>Specifies up to three lines of description text for the drawing file. The description displays in title block updates and custom drawing properties. The values are saved in the project <i>.wdp</i> file. Select from a list of predefined descriptions from the active project by clicking the arrow or select a description from the drawing by clicking Pick.</p>
<b>For Reference Only</b>	<p>Indicates that the drawing is not included in tagging, cross-referencing, and reporting functions. If selected, the drawing is included in project-wide plotting and title block operations. This setting is saved in the project <i>.wdp</i> file.</p>

### IEC-Style Designators

Specifies IEC default values for the drawing, such as Project (%P), Installation (%I), and Location (%L) fields. When you insert a component, the %I and %L default values are used if the Installation and/or Location values would normally be blank.

<b>Project Code</b>	<p>Specifies a project code for the WD_M block definition. This value can be used as the replaceable parameter %P.</p>
<b>Installation Code</b>	<p>Specifies the installation code for the WD_M block definition. This value can be used as the replaceable parameter %I.</p>
<b>Location Code</b>	<p>Specifies the location code for the WD_M block definition. This value can be used as the replaceable parameter %L.</p>

<b>Drawing</b>	Displays a list of Installation or Location codes from the active drawing.
<b>Project</b>	Displays a list of previously defined Installation or Location codes in the active project or from the Default.INST or Default.LOC file.

---

**NOTE** Avoid using a mixture of drawings in the project when using the Combine Installation/Location Tag mode. For example, do not include some drawings with drawing-wide Installation or Location values and some without drawing-wide values. It can result in a disruption of the child and parent component relationship under certain circumstances.

---

### Sheet Values

Component, wire, and cross-reference tagging use replaceable parameters in their format. If you reference the sheet number or drawing number in any of your tagging formats, then specify a default drawing-wide value to use.

<b>Sheet</b>	Specifies the sheet number value for the drawing settings. This value can be used as the replaceable parameter %S.
<b>Drawing</b>	Specifies the drawing number value for the drawing settings. This value can be used as the replaceable parameter %D.
<b>Section</b>	Specifies the section value for the drawing file saved in the project definition file (.wdp). This value can be used as the replaceable parameter %A.
<b>Sub-Section</b>	Specifies the subsection value for the drawing file saved in the project definition file (.wdp). This value can be used as the replaceable parameter %B.

## Drawing properties: components tab

Apply a drawing-specific component settings that are maintained inside the WD\_M block of the drawing.

### Any drawing

 **Ribbon:** Project tab ► Project Tools panel ► Manager. 



 **Toolbar:** Main Electrical 2

 **Menu:** Projects ► Project Manager

 **Command entry:** AEPROJECT

In the Project Manager, right-click the drawing name, and select Properties ► Drawing Properties. Select the Components tab.

### Active drawing

 **Ribbon:** Schematic tab ► Other Tools panel ► Drawing Properties

drop-down ► Drawing Properties.



 **Toolbar:** Main Electrical 2

 **Menu:** Projects ► Drawing Properties

 **Command entry:** AEPROPERTIES

Select the Components tab.



### Tag Format

Specifies the way new component tags are created. The tag consists of a minimum of two pieces of information: a family code and an alphanumeric reference number (for example, "CR" and "100" to yield a tag like CR100 or 100CR). Optionally, a component tag might contain a sheet number or some user-specified separators. If your format includes the sheet number %S parameter or the drawing number %D parameter, enter the values in the edit boxes in the Drawing Properties ► Drawing Settings dialog box.

---

**NOTE** AutoCAD Electrical provides a predefined format for you to use or you can enter your own format using [replaceable parameters](#) on page 236.

---

**NOTE** The %N parameter is mandatory in any component tag format you define.

---

<b>Search for PLC I/O address on insert</b>	<p>Searches for a connected PLC I/O module's I/O point. If found, the I/O address value is substituted for the "%N" part of the default component tag.</p> <hr/> <p><b>NOTE</b> This setting is saved in the MISC_FLAGS attribute on the WD_M block of the drawing.</p> <hr/>
<b>Sequential</b>	<p>Enter the beginning sequential number for the drawing. Sequential tags can continue uninterrupted from one drawing to the next if you assign the same beginning sequential number to every drawing in your project. As you insert components on any drawing of the project set, AutoCAD Electrical starts with the value you set and works its way up until it finds the next unused sequential number tag for the target component family.</p> <hr/> <p><b>NOTE</b> If you finish a drawing and move to the next, but then later come back to the first drawing to add another component and sequential tag, a gap appears in the numbering sequence for that drawing. Use the AutoCAD Electrical Project-wide Update/Retag tool to retag the whole drawing set.</p> <hr/>
<b>Line Reference</b>	<p>Set up the unique format tag suffix list. Use this list to create unique reference-based tags when multiple components of the same family are located at the same reference location (for example, three push buttons on the same line reference "101" could be labeled PB101, PB101A, and PB101B -- AutoCAD Electrical does this using a suffix list of " ", "A", "B", and so on).</p> <hr/> <p><b>NOTE</b> The component tag suffix is automatically added to the end of the tag, but you can force AutoCAD Electrical to insert the suffix character somewhere within the tag format. Use the Suffix position parameter, %X, in the component tag format (for example, %N%X - %F).</p> <hr/>
<b>Suffix Setup</b>	<p>Displays the suffix list. The individual items in the suffix list are given in the row of edit boxes across the top of the dialog box. List suffix characters for duplicate family components on the same line refer-</p>

ence or in the same zone (to keep tags unique). The suffix is added to the end of the component tag. To add it to the inside of the tag, use "%X" in the Tag Format. Example:

%N-%F or %N-%F%X = suffix at the end (such as 101-CRA)

%N%X-%F = add to number, before family code (such as 101A-CR)

Select from the default lists or manually enter your own suffix list in the row of edit boxes.

## Drawing properties: wire numbers tab

Apply drawing-specific wire number settings. These settings are maintained inside the WD\_M block in the drawing.

### Any drawing

 **Ribbon:** Project tab > Project Tools panel > Manager. 

 **Toolbar:** Main Electrical 2 

 **Menu:** Projects > Project Manager

 **Command entry:** AEPROJECT

In the Project Manager, right-click the drawing name, and select Properties > Drawing Properties. Select the Wire Numbers tab.

### Active drawing

 **Ribbon:** Schematic tab > Other Tools panel > Drawing Properties

drop-down > Drawing Properties. 

 **Toolbar:** Main Electrical 2 

 **Menu:** Projects > Drawing Properties

 **Command entry:** AEPROPERTIES

Select the Wire Numbers tab.

## Wire Number Format

Wire number tags can be sequential or reference-based.

### Format

Specifies the way new wire number tags are created. The wire number tag format must include the %N parameter that is the base sequential or reference-based value per the selection above. If your format includes the sheet number %S parameter or the drawing number %D parameter, enter the values in the edit boxes in the Drawing Properties ► Drawing Settings dialog box.

---

**NOTE** For reference-based wire number tagging, individual items in the suffix list are applied to the wire tags to keep multiple wires in the same reference location unique. These values are added to the end of the tag, but you can force AutoCAD Electrical to insert the suffix character somewhere within the tag format. Use the Suffix position parameter, %X, in the component tag format (for example, %X%N).

---

### Search for PLC I/O address on insert

Specifies to use PLC I/O address values for wires that connect to an addressed I/O point. This setting overrides both Sequential and Reference-based tagging. New wires or wire renumbering on the current drawing shows PLC I/O address-based wire numbers automatically.

---

**NOTE** Like component tags, AutoCAD Electrical uses the concept of a wire tag format string with replaceable parameters. The %N parameter must always be part of the wire format string. A typical format string can be just this %N parameter.

---

### Sequential

Enter the starting sequential number (alpha, numeric, or alphanumeric) for the drawing. If you enter the same starting sequential number for every drawing of your wiring diagram set, AutoCAD Electrical confirms at insertion time that a new sequential wire number tag is not repeated on any other drawing.

If you set DEMO1 to 100 and DEMO2 to 200, the wire numbers on DEMO1 start at 100 and wire numbers on DEMO2 start at 200. If DEMO1 has more than 100 wire numbers it starts using wire number 200 and above. DEMO2 would begin its wire numbers where DEMO1 left

	off (making sure that duplicate wire numbers are not assigned).
<b>Increment</b>	The default is "1." Setting it to "2" with a starting sequential of "1" would yield wire numbers 1, 3, 5, 7, 9, 11, and so on.
<b>Line Reference</b>	Sets the wire number tag suffix. This list is used to create unique reference-based wire number tags for multiple wire networks beginning at the same reference location (such as wire network beginning at a location per line reference number, X-Y grid reference, or X-Zone reference).
<b>Suffix Setup</b>	Displays a suffix list. List suffix characters for wire numbers beginning on the same line reference or in the same zone (to keep wire numbers unique). Select one of the four predefined suffix lists or enter your own custom suffix list.

### **New Wire Number Placement**

---

**NOTE** The Insert Wire Number tool does not take the current wire number setting (in-line, above or below) into account when updating existing wire numbers. This setting is used only when inserting new wire numbers. Use the Toggle Wire Number In-Line tool for flipping existing wire numbers among the three modes.

---

<b>Above Wire</b>	Places the wire number above the physical wire.
<b>In-Line</b>	Places the wire number inline with the wire.
<b>Gap Setup</b>	Defines spacing between the inline wire number and the wire itself.
<b>Below Wire</b>	Places the wire number below the physical wire.
<b>Offset</b>	Specifies to insert the wire number tags the specified offset distance.
<b>Centered</b>	Specifies to insert the wire number tags in the center of each wire segment.
<b>Offset Distance</b>	Specifies a fixed, user-defined offset distance from the left or top of the first wire segment found on the wire network.

## Leaders

(This option is unavailable for in-line wire numbers.) AutoCAD Electrical places wire numbers on leaders when it determines that the wire number text bumps into something. It does not check if the leader itself overlays another object. Select the method for inserting new wire numbers as leaders: As Required, Always, or Never.

---

**NOTE** This change does not affect wire numbers that are already present on the drawing.

---

## Drawing properties: cross-references tab

Apply a drawing-specific cross-reference settings that are maintained inside the WD\_M block of the drawing. This overrides the project settings since cross-referencing commands look at the WD\_M block as the definition for all referencing on the drawing during runtime.

### Any drawing

 **Ribbon:** Project tab > Project Tools panel > Manager. 

 **Toolbar:** Main Electrical 2 

 **Menu:** Projects > Project Manager

 **Command entry:** AEPROJECT

In the Project Manager, right-click the drawing name, and select Properties > Drawing Properties. Select the Cross-References tab.

### Active drawing

 **Ribbon:** Schematic tab > Other Tools panel > Drawing Properties

drop-down > Drawing Properties. 

 **Toolbar:** Main Electrical 2 

 **Menu:** Projects > Drawing Properties

 **Command entry:** AEPROPERTIES



Select the Cross-References tab.

### Cross-reference Format

Defines the cross-reference annotation format. One replaceable parameter, %N, must always be part of the cross-reference format string. A typical format string might be just the %N parameter. Use Same Drawing for on-drawing references and Between Drawings for off-drawing references. You can use the same format for both.

---

**NOTE** AutoCAD Electrical provides some predefined formats for you to use or you can enter your own format using [replaceable parameters](#) on page 236.

---

### Component Cross-reference Display

There are different styles of cross referencing AutoCAD Electrical supports:



<b>Text Format</b>	Displays cross-referencing as text with any string as a separator between references on the same attribute.
<b>Graphical Format</b>	Displays cross-referencing using the AutoCAD Electrical graphical font or using contact mapping edit boxes while displaying each reference on a new line.
<b>Table Format</b>	Displays cross-referencing in a table object, that automatically gets updated in real time. You can define the columns to display.
<b>Setup</b>	Displays a dialog box for setting the display defaults for each component cross-reference display format.

## Drawing properties: styles tab

Apply drawing-specific component styles settings. These settings are maintained inside the WD\_M block in the drawing.

### Any drawing

 **Ribbon:** Project tab ► Project Tools panel ► Manager. 

 **Toolbar:** Main Electrical 2 

 **Menu:** Projects ► Project Manager

 **Command entry: AEPROJECT**

In the Project Manager, right-click the drawing name, and select Properties  
➤ Drawing Properties. Select the Styles tab.

**Active drawing**

 **Ribbon:** Schematic tab ➤ Other Tools panel ➤ Drawing Properties

drop-down ➤ Drawing Properties.

 **Toolbar:** Main Electrical 2

 **Menu:** Projects ➤ Drawing Properties

 **Command entry: AEPROPERTIES**

Select the Styles tab.

<b>Arrow Style</b>	<p>Specifies the default wire signal arrow style. Select from the four predefined styles or a user-defined style. You can override the default style setting at insertion time.</p> <hr/> <p><b>TIP</b> For instructions on how to add custom wire arrow styles, see <a href="#">Add custom signal arrow styles</a> on page 1011.</p> <hr/>
<b>PLC Style</b>	<p>Specifies the default PLC module style. Select from the five predefined styles or a user-defined style.</p> <hr/> <p><b>TIP</b> For instructions on how to add custom PLC module styles, see <a href="#">Add a new PLC style</a> on page 624.</p> <hr/>
<b>Fan-In/Out Marker Style</b>	<p>Defines the default Fan In/Out marker style and the layers for wires going out of a Fan In/Out Source marker and those coming into a Destination marker.</p> <hr/> <p><b>TIP</b> For instructions on how to add custom Fan-In/Out marker styles, see <a href="#">Add custom fan-in/out marker styles</a> on page 1023.</p> <hr/>
<b>Layer List</b>	<p>Lists the Fan In/Out layers.</p>
<b>Add</b>	<p>Defines layer names as Fan In/Out layers.</p>
<b>Remove</b>	<p>Removes the selected layer from the defined layer list.</p>

<b>Wire Cross</b>	Specifies the default mode of operation when wires cross each other: insert gap with no loop, insert gap, and loop, or solid (no gap).
<b>Wire Tee</b>	Specifies the default wire tee marker: none, dot, angle1, or angle2.

## Drawing properties: drawing format tab

Apply a drawing-specific format settings that are maintained inside the WD\_M block of the drawing.

### Any drawing

 **Ribbon:** Project tab ► Project Tools panel ► Manager.



 **Toolbar:** Main Electrical 2



 **Menu:** Projects ► Project Manager

 **Command entry:** AEPROJECT

In the Project Manager, right-click the drawing name, and select Properties ► Drawing Properties. Select the Drawing Format tab.

### Active drawing

 **Ribbon:** Schematic tab ► Other Tools panel ► Drawing Properties

drop-down ► Drawing Properties.



 **Toolbar:** Main Electrical 2



 **Menu:** Projects ► Drawing Properties

 **Command entry:** AEPROPERTIES

Select the Drawing Format tab.

### Ladder Defaults

<b>Vertical/Horizontal</b>	Specifies whether to create ladders horizontally or vertically.
----------------------------	---

<b>Spacing</b>	Specifies the spacing between each ladder rung.
<b>Default: insert new ladders without references</b>	Sets the default for the Insert Ladder command. New ladders you insert do not have line reference numbering, by default.
<b>Width</b>	Specifies the width of the ladder.
<b>Multi-wire Spacing</b>	Specifies the spacing between each wire in multi-wire phases.

### Format Referencing

Specifies the default referencing system. There are three modes:

<b>X-Y Grid</b>	<p>All referencing is tied to an X-Y grid system of numbers and letters along the left-hand side and top of the drawing. Set the vertical and horizontal index numbers and letters, spacing, and origin in the X-Y grid setup dialog box.</p> <hr/> <p><b>TIP</b> Use negative spacing values for Horizontal or Vertical if you want to change the origin of the X-Y grid system to be other than the upper left-hand corner of the drawing.</p> <hr/>
<b>X Zones</b>	<p>Like X-Y Grid, but there is not a Y-axis. Set the horizontal labels, spacing, and origin on the X Zones setup dialog box.</p> <hr/> <p><b>TIP</b> Use a negative zone spacing value if you want the zone reference origin to be at the right side of the drawing.</p> <hr/>
<b>Reference Numbers</b>	Each ladder column has a column of assigned reference numbers.
<b>Setup</b>	Specifies how to display ladder line reference numbers - number only, numbers in a hexagon, the sheet and number values, and so on.

### Scale

<b>Feature Scale Multiplier</b>	Sets the scale factor used when inserting new components or wire numbers on the drawing. To insert everything 25% bigger than normal, change the edit box value from 1.00 to 1.25. This change does not
---------------------------------	---

affect components and wire numbers that are already present on the drawing.

**inch/inch scaled to mm/mm full size**

Select inch if your drawing is to use library symbols from the JIC1/JIC125 libraries or mm full size for the metric scaled symbol libraries. It adjusts the wire connection trap distance that determines whether closely spaced wire ends connector not.

### Tag/Wire Number Order

**Sort Order**

Sets the default wire numbering sort order for the active drawing. You can set sorting on a per-drawing basis and override the project-wide default setting defined in Properties ► Wire Numbers dialog box. For example, you can set the wire numbers to go in a reverse order from the I/O point on a PLC I/O drawing, but have the wire numbers going from left to right for non-PLC I/O drawings.

### Layers

**Define**

Defines and manages wire and component layers.

---

**NOTE** No matter what layer is current, wires always go to a wire layer and components to component layers.

---

## X zones setup

Use this tool to insert the X grid labels for drawings that use X Zones for the Format Referencing. You can also change other settings from here (such as origin) instead of going back into the Drawing Properties dialog box.

 **Ribbon:** Schematic tab ► Insert Wires/Wire Numbers panel ► Insert

Ladder drop-down ► X Zones Setup.

 **Toolbar:** Ladders

 **Command entry:** AEXZONE

Your drawing must be configured for X Zones. Set the Format Referencing in the Drawing Properties: Drawing Format dialog box to X Zones.

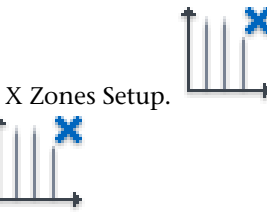

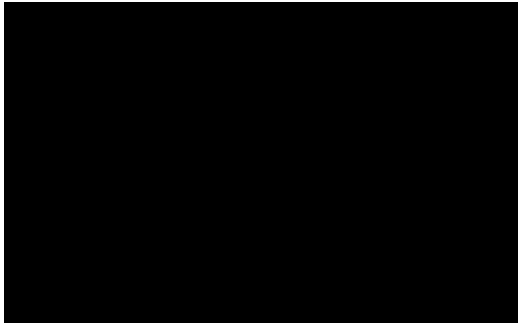

---

**NOTE** You can also access this dialog box from the Project Properties or Drawing Properties dialog boxes. Some options are not available when you access the dialog box through the properties dialog boxes.

---

<b>Origin</b>	Specifies the origin for the X Zone grid. Click pick to select the origin on the drawing or enter X and Y values. <hr/> <b>NOTE</b> The Pick button is not available when accessed through the properties dialog box. <hr/>
<b>Spacing</b>	Specifies the spacing between the grid columns. Enter the horizontal value.
<b>Zone labels</b>	(only available when accessed from the ribbon, toolbar, or menu) Specifies the labels for the grid columns. Enter the horizontal value. You can enter the first value only or a complete list. If you enter a list, separate the values with commas - such as "A, B, C, D."
<b>Insert zone labels</b>	(only available when accessed from the ribbon, toolbar, or menu) Specifies whether to insert the grid labels. If you select to insert the labels, enter the column counts.

### **X-Y grid setup**

Use this tool to insert the X-Y grid labels for drawings that use X-Y Grid for the Format Referencing. You can also change other settings from here (such as origin) instead of going back into the Drawing Properties dialog box.

 **Ribbon:** Schematic tab ► Insert Wires/Wire Numbers panel ► Insert

Ladder drop-down ► XY Grid Setup.



 **Command entry:** Ladders

 **Command entry:** AEXYGRID



Your drawing must be configured for X-Y Grids. Set the Format Referencing in the Drawing Properties: Drawing Format dialog box to X-Y Grid.



---

**NOTE** You can also access this dialog box from the Project Properties or Drawing Properties dialog boxes. Some options are not available when you access the dialog box through the properties dialog boxes.

---

**Origin**

Specifies the origin for the XY grid. Click pick to select the origin on the drawing or enter X and Y values.

---

**NOTE** The Pick button is not available when accessed through the properties dialog box.

---

**Spacing**

Specifies the spacing between the grid columns. Enter the horizontal and vertical values.

**X-Y Format**

Specifies the order that is used from the X-Y grid in determining the %N part of the tag. If it is set to Horizontal, the horizontal values of the grid are used as the first part, and the vertical value as the second. If Vertical is selected then the vertical values are used for the first part and the horizontal values used for the second. For example, you have Horizontal values of A - F and Vertical values of 1 - 9 and it is set to

Horizontal. You might get a %N value of "B2"; if it is set to Vertical you might get a %N value of "2B."

**Grid labels**

(only available when accessed from the ribbon, toolbar, or menu)  
Specifies the labels for the grid columns. Enter the horizontal and vertical values. You can enter the first value only or a complete list. If you enter a list, separate the values with commas - such as "A, B, C, D."

**Insert X-Y grid labels**

(only available when accessed from the ribbon, toolbar, or menu)  
Specifies whether to insert the grid labels. If you select to insert the labels, enter the horizontal and vertical column counts.

## Use replaceable parameters

The Drawing Properties dialog box makes use of codes as replaceable parameters that are encoded on to attributes of the invisible WD\_M block of the drawing. For example, if you set your component tag format to be %F%N, this format is encoded on to the TAGFMT attribute of the WD\_M block. When AutoCAD Electrical assigns a TAG to a component, this format is read and the codes are replaced with the appropriate values.

Replaceable parameters are also used for device tagging, cross-referencing, wire numbering, wire annotation, and graphical terminal strips.

### For device tagging, cross-referencing and wire numbering

Defined in the Drawing Properties.

%F	Component family code string (for example, "PB," "SS," "CR," "FLT," "MTR")
%S	Sheet number of the drawing (for example, "01" entered in upper right)
%D	Drawing number
%G	Wire layer name
%N	Sequential or Reference-based number applied to the component
%X	Suffix character position for reference-based tagging (not present = end of tag)



<b>%P</b>	IEC-style project code (default for drawing)
<b>%I</b>	IEC-style installation code (default for drawing)
<b>%L</b>	IEC-style location code (default for drawing)
<b>%A</b>	Project drawing list's SEC value for active drawing
<b>%B</b>	Project drawing list's SUB-SEC value for active drawing

The %L and %I values used for cross-referencing are the Drawing Default Location and Installation values from the corresponding Parent or Child drawing and not the Location and Installation values of the component itself. If you have a Parent on a drawing that has a default Location of “M” and its child is on a drawing that has a default Location value of “MC,” the cross-referencing on the parent shows the “MC” (drawing default location value of the drawing the child is on) and the child shows the “M” (drawing default location value of the drawing the parent is on) no matter what the location value is on either the parent or child.

---

**NOTE** If you include %I or %L in the Tag code of the component, you are prompted to recalculate the tag if you change the Installation or Location value of the component once it is inserted.

---

#### **Example of Component Tags**

(For relay number 50 on sheet 3)

%F%S%N = CR350

%F%N = CR50

%F-%S-%N = CR-3-50

(For 3 push buttons on line reference 101 using reference-based tagging)

%F%N = PB101, PB101A, PB101B

%N-%F = 101-PB, 101-PBA, 101-PBB

%N%X%F = 101-PB, 101A-PB, 101B-PB

#### **Example of Wire Number Formats**

(For wire number 50 on sheet 3)

%S/%N = 3/50

%N = 50

W-%S%N = W-350

### For defining wire annotation and graphical terminal strips

<b>%P</b>	Terminal pin text
<b>%Q</b>	Terminal pin TERMDESC text
<b>%I</b>	IEC-style installation code
<b>%L</b>	IEC-style location code
<b>%M</b>	Mount assignment (on panel footprint equivalent)
<b>%U</b>	Group assignment (on panel footprint equivalent)
<b>%W</b>	Wire number
<b>%C</b>	Cable tag + conductor/core color combination (format is "tag-color")
<b>%E</b>	Cable tag
<b>%J</b>	Cable conductor/core color
<b>%V</b>	Cable tag substituted for wire number if cable tag is non-blank. The wire number is displayed when a cable ID does not exist.
<b>%G</b>	Wire color/gauge (or wire layer name)
<b>%H</b>	Cable wire color substituted for wire number if cable color is non-blank. The wire layer is displayed when a wire conductor in conjunction with a cable ID does not exist.
<b>%T</b>	Terminal strip terminal pin assignment
<b>%K</b>	Terminal strip TERMDESC text - useful for multi-stack terminals
<b>%1</b>	Destination component tag ID. You can use only one of the (%number) parameters.
<b>%2</b>	Equivalent of "%1:%P" (comp tag:term)
<b>%3</b>	Equivalent of "%1:%P:%D" (comp tag:term:termdesc)

%4	Equivalent of "%L%1" (IEC comp tag)
%5	Equivalent of "%L%1:%P" (tag:term)
%6	Equivalent of "%L%1:%P:%D" (tag:term:termdesc)
%7	Equivalent of "%I%I%1" (INST prefix+IEC comp tag)
%8	Equivalent of "%I%L%1:%P" (tag:term)
%9	Equivalent of "%I%L%1:%P:%D" (tag:term:termdesc)

The part after the colon(:) is suppressed if the value is blank in %2 - %9 parameters (for example, %2=comp tag:term). The ":term" part is suppressed if blank.

## Save settings to the project file

### Save settings to the project file

The changes you make to the configuration of the current drawing are saved on the invisible WD\_M block of the drawing. You can save a copy of these settings to the project file. It makes the settings available as defaults for new drawings that you might add later to the project. Alternately, you can retrieve selected settings previously saved in the project file and assign them to the current drawing.

- 1 Click Schematic tab ► Other Tools panel ► Drawing Properties



drop-down ► Settings Compare.

AutoCAD Electrical reads both the settings on the WD\_M block of the current drawing and a copy of the settings maintained in the current project's .wdp file. Any differences are displayed in a three-column dialog box.

- 2 Highlight the settings you want to copy over from the drawing to the project or vice versa or click Select All to change all the settings quickly.
- 3 Click Match Project to make the settings of the drawing match the project defaults or click Match Drawing to make the settings of the project match the settings of the current drawing.

4 Click OK.

---

**NOTE** Changing these settings does not automatically change components and wiring already present in your drawing.



---

## Compare drawing and project settings

Displays differences between project defaults and drawing default properties and allows an update.

 **Ribbon:** Schematic tab ► Other Tools panel ► Drawing Properties

drop-down ► Settings Compare. 

 **Toolbar:** Drawing Properties 

 **Menu:** Projects ► Settings Compare

 **Command entry:** AESHEETCOMPARE

This tool compares the general/schematic settings carried on the invisible WD\_M block of the drawing with a copy of the settings saved in the project's .wdp project list file. You can update selected drawing settings (multiple selection is allowed) to make them match the values carried in the master project file or vice versa.

If the Settings Description cell displays in light blue the project and drawing settings do not match. When one column is matched to the other, the cell changes in color to indicate that the record were changed. The dialog box list updates automatically when you make changes and then switch between showing all settings or showing just the different settings.

---

**NOTE** Changing these settings does not automatically change components and wiring already present in your drawing.

---

**NOTE** You can also access this dialog box by right-clicking a drawing name in the Project Manager and selecting Properties ► Settings Compare.

---

You can also right-click any row to access the Match Project or Match Drawing options.

**Show All**

Shows all of the settings in the drawing.

<b>Show Differences</b>	Displays settings that are different between the WD_M block and the .wdp file.
<b>Select All</b>	Selects all of the settings in the list so you can quickly change all settings to match either the project or the drawing.
<b>Match Project</b>	Changes the selected drawing setting to make it match the project. Select the settings from the list, and then click the button.
<b>Match Drawing</b>	Changes the selected project default setting to make it match the drawing. Select the settings from the list, and then click the button.

## Settings List Utility

### Settings List Utility



Reports the settings of each drawing in the project, and provides the means to edit the report and update the drawing properties with the edited values.

- 1 Click Project tab ➤ Other Tools panel ➤  ➤ Settings List Utility.



- 2 Click Edit Mode.
- 3 Edit the values or change the drawing order.
- 4 Click OK-Return to Report.
- 5 Click Close.
- 6 Select the options for update.
- 7 Click OK.

### Edit report

 **Ribbon:** Project tab > Other Tools panel >  > Settings List

  
Utility.

 **Menu:** Projects > Extras > Settings List Utility

 **Command entry:** AEDWGCFG

Click Edit Mode.

If you edit the information in the Configuration Report, you have an option to update the project and drawings with the new information. Re-order the lines with the Move Up, Move Down, Move to Top, and Move to Bottom buttons. If you re-order the lines, the order of the drawing list in the project file (.WDP) can be updated to match.

<b>Move Up</b>	Moves the currently selected lines up one place in the report.
<b>Move Down</b>	Moves the currently selected lines down one place in the report.
<b>Move to Top</b>	Moves the currently selected lines to the top of the report.
<b>Move to Bottom</b>	Moves the currently selected lines to the bottom of the report.



### **Edit**

Edits the values of the currently selected line. Double-click any line to go directly into edit.

<b>DWGNAM</b>	Specifies the drawing name.
<b>SEC</b>	If you change any of the Sec data, the Section data held in the project file (.WDP) can be updated to match.
<b>SUBSEC</b>	If you change any of the SubSec data, the Sub-Section data held in the project file (.WDP) can be updated to match.
<b>SH</b>	If you change any of the SH data, the Sheet (%S) field for that drawing can be updated to match.

<b>SHDWGNAM</b>	If you change any of the SHDWGNAM data, the Dwg no. (%D) field for that drawing can be updated to match.
<b>IEC_P</b>	If you change any of the IEC_P data, the IEC Project (%P) field for that drawing can be updated to match.
<b>IEC_I</b>	If you change any of the IEC_I data, the IEC Installation (%I) field for that drawing can be updated to match.
<b>IEC_L</b>	If you change any of the IEC_L data, the IEC Location (%L) field for that drawing can be updated to match.
<b>SH-DESC</b>	If you change any of the SH-DESC data, the Description data held in the project file (.WDP) can be updated to match.

## Update Configuration Changes

 **Ribbon:** Project tab ► Other Tools panel ►  ► Settings List



Utility.

 **Menu:** Projects ► Extras ► Settings List Utility

 **Command entry:** AEDWGCFCG

- 1 Click Edit Mode.
- 2 Edit the values or change the drawing order.
- 3 Click OK-Return to Report.
- 4 Click Close.

If you edit the information in the Configuration Report, you have an option to update the project and drawings with the new information. Re-order the lines with the Move Up, Move Down, Move to Top, and Move to Bottom buttons. If you re-order the lines, the order of the drawing list in the project file (.WDP) can be updated to match.

**Drawing Order (in .WDP)** Update the drawing order in the project file (.WDP).

**Section (in .WDP)** Update the Section data held in the project file (.WDP).

<b>Sub-Section (in .WDP)</b>	Update the Sub-Section data held in the project file (.WDP).
<b>Sheet (%S) (on drawing)</b>	Update the Sheet (%S) data on each drawing.
<b>Drawing (%D) (on drawing)</b>	Update the Dwg no. (%D) data on each drawing.
<b>IEC Project (%P) (on drawing)</b>	Update the IEC Project (%P) data on each drawing.
<b>IEC Installation (%I) (on drawing)</b>	Update the IEC Installation (%I) data on each drawing.
<b>IEC Location (%L) (on drawing)</b>	Update the IEC Location (%L) data on each drawing.
<b>Description (in .WDP)</b>	Update the first Description data held in the project file (.WDP).

## Create a template drawing

### Create a template drawing

Using a template, you can start a new drawing with the WD\_M block inserted, settings adjusted, and standard AutoCAD Electrical layers predefined. With this template, AutoCAD Electrical does not have to pause and ask permission to insert the block as you start each new wiring diagram drawing.

- 1 Open a new drawing or start with a copy of your standard drawing border/title block drawing.
- 2 Click Schematic tab ► Other Tools panel ► Drawing Properties



drop-down ► Drawing Properties.

It triggers AutoCAD Electrical to insert the invisible WD\_M block.

- 3 In the Drawing Properties dialog box, modify any drawing settings (such as layer naming conventions and tagging formats) and click OK.
- 4 Select Format ► Layer to create any layers you referenced in the Drawing Properties dialog box.
- 5 In the AutoCAD Layer Properties Manager dialog box, adjust layer colors and click Apply.



- 6 Save the drawing as an AutoCAD Drawing Template file with a .DWT extension.  
This template appears in the list of saved templates the next time you open a new AutoCAD Electrical drawing.

### See also:

- [Title block](#) on page 1208
- [Title Block tutorial](#) on page 1707

## Drawing properties: drawing settings tab

Sets default values for a drawing.

### Any drawing

 **Ribbon:** Project tab ► Project Tools panel ► Manager. 

 **Toolbar:** Main Electrical 2 

 **Menu:** Projects ► Project Manager

 **Command entry:** AEPROJECT

In the Project Manager, right-click the drawing name, and select Properties ► Drawing Properties. Select the Drawing Settings tab.

### Active drawing

 **Ribbon:** Schematic tab ► Other Tools panel ► Drawing Properties

drop-down ► Drawing Properties. 

 **Toolbar:** Main Electrical 2 

 **Menu:** Projects ► Drawing Properties

 **Command entry:** AEPROPERTIES

Select the Drawing Settings tab.

Sets the values you enter for drawing description, project, installation, location, sheet, and drawing code. Sets the format for component tags, wire numbers, cross-references, PLC modules, signal arrows, ladders, and layers. Overrides the project properties set in the project Properties dialog box.

### Drawing File

<b>Project</b>	<p>Specifies the project that the drawing is found in.</p> <hr/> <p><b>NOTE</b> If the drawing is not in any of the currently open projects, "Drawing not in open project" displays instead of the project name. If the drawing is in an open project but it cannot be edited, "Project not available for edit" displays instead of the project name. This alert displays when a project file is read only, locked by someone else, not checked out in Vault, or the folder where the project is located is read only. When the project is not open or available for edit, you are unable to assign a description for the drawing.</p> <hr/>
<b>Description 1-3</b>	<p>Specifies up to three lines of description text for the drawing file. The description displays in title block updates and custom drawing properties. The values are saved in the project <i>.wdp</i> file. Select from a list of predefined descriptions from the active project by clicking the arrow or select a description from the drawing by clicking Pick.</p>
<b>For Reference Only</b>	<p>Indicates that the drawing is not included in tagging, cross-referencing, and reporting functions. If selected, the drawing is included in project-wide plotting and title block operations. This setting is saved in the project <i>.wdp</i> file.</p>

### IEC-Style Designators

Specifies IEC default values for the drawing, such as Project (%P), Installation (%I), and Location (%L) fields. When you insert a component, the %I and %L default values are used if the Installation and/or Location values would normally be blank.

<b>Project Code</b>	<p>Specifies a project code for the WD_M block definition. This value can be used as the replaceable parameter %P.</p>
---------------------	--

<b>Installation Code</b>	Specifies the installation code for the WD_M block definition. This value can be used as the replaceable parameter %I.
<b>Location Code</b>	Specifies the location code for the WD_M block definition. This value can be used as the replaceable parameter %L.
<b>Drawing</b>	Displays a list of Installation or Location codes from the active drawing.
<b>Project</b>	Displays a list of previously defined Installation or Location codes in the active project or from the Default.INST or Default.LOC file.

---

**NOTE** Avoid using a mixture of drawings in the project when using the Combine Installation/Location Tag mode. For example, do not include some drawings with drawing-wide Installation or Location values and some without drawing-wide values. It can result in a disruption of the child and parent component relationship under certain circumstances.

---

### Sheet Values

Component, wire, and cross-reference tagging use replaceable parameters in their format. If you reference the sheet number or drawing number in any of your tagging formats, then specify a default drawing-wide value to use.

<b>Sheet</b>	Specifies the sheet number value for the drawing settings. This value can be used as the replaceable parameter %S.
<b>Drawing</b>	Specifies the drawing number value for the drawing settings. This value can be used as the replaceable parameter %D.
<b>Section</b>	Specifies the section value for the drawing file saved in the project definition file (.wdp). This value can be used as the replaceable parameter %A.
<b>Sub-Section</b>	Specifies the subsection value for the drawing file saved in the project definition file (.wdp). This value can be used as the replaceable parameter %B.

# Updating the WD\_M Block

## Overview of the WD\_M block

A special invisible block must be present on the drawing. The WD\_M.dwg is found in the default symbol library. Here is an attribute list of information that is carried on the WD\_M block of the drawing, sorted by category:

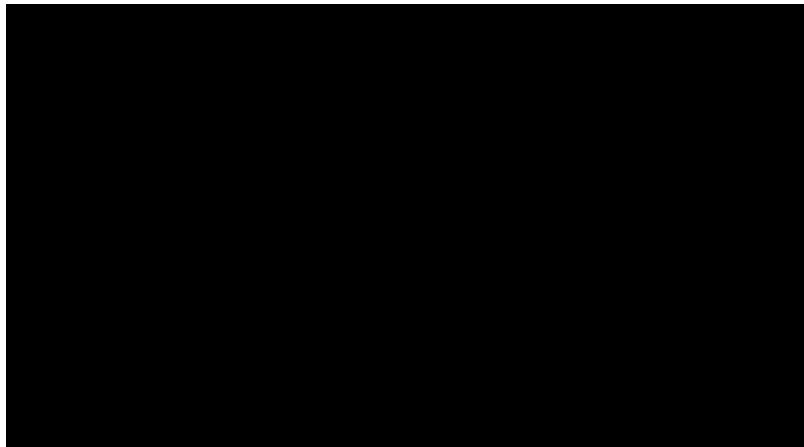

### Drawing layout

<b>SHEET or SHEET_</b>	sheet number for the drawing (%S)
<b>SHEETDWGNAME</b>	optional drawing number for the drawing (%D)
<b>IEC_PROJ</b>	optional IEC project code (%P)
<b>IEC_INST</b>	optional IEC installation code (%I)
<b>IEC_LOC</b>	optional IEC location code (%L)
<b>UNIT_SCL</b>	units scaling factor (1.0 = inch, 1.0 = full-size mm, 25.4 = inch scaled up to mm)
<b>FEATURE_SCL</b>	scaling adjustment (0 = default, 1.25=for 25% bigger)

### Ladder defaults

RUNGHORV	ladder orientation: "H" = horizontal rungs (vertical ladders); "V" = vertical rungs (horizontal ladders)
REFNUMS	reference numbering system: ladder line reference-based or X-Y grid reference-based <ul style="list-style-type: none"><li>■ 1 = line reference numbers</li><li>■ 2 = numbers with ruling</li><li>■ 3 = user-defined line reference block</li><li>■ 4 = X-Y grid reference mode</li><li>■ 5 = X-Zone reference mode</li></ul>
RUNGDIST	default rung spacing
DLADW	default ladder width
RUNGINC	default rung-to-rung line reference increment (default = 1)
DRWRUNG	draw ladder rungs: 0 = none, 1 = draw all rungs for new ladder, 2 = skip 1, 3 = skip 2, and so on.
PH3SPACE	3-phase bus spacing value

### Component tagging

TAGMODE	tag mode value: S = sequential, R = reference-based
TAG-START	starting sequential number of the drawing -for sequential tagging only (that is, "1")
TAG-RSUF	comma-delimited component tag suffix list -for reference- based tagging only (that is, "A, B, C")
TAGFMT	component tag format specifier (default=%F%N)

### Wire number tagging

WIREMODE	wire number format: S = sequential, R = reference-based
----------	---

<b>WIRE-START</b>	starting sequential number of the drawing - for sequential tagging only (that is, "100")
<b>WIRE-RSUF</b>	wire tag suffix list - for reference-based tagging only (that is, "A,B,C")
<b>WIREFMT</b>	wire tag format specifier (default=%N)
<b>WINC</b>	wire number increment
<b>WLEADERS</b>	wire leaders: 0 = only as required, 1 = always insert wire leaders, 2 = never insert leaders
<b>GAP_STYLE</b>	wire gap style: 0 = wire gap, 1 = use loops across gaps, 2 = solid crossing (no gap)
<b>SORTMODE</b>	retag and wire numbering sort mode
<b>WNUM_OFFSET</b>	wire number placement offset distance (GBL_wd_wnum_offset); same as the project-wide +[19] value in the .wdp file. 0.0 or missing= centered on wire (default), >0.0 = offset from top or left end by given distance
<b>WNUM_FLAGS</b>	<ul style="list-style-type: none"> <li>■ 1's bit set = (GBL_wd_inline_gap global) auto in line wire gap adjust "ON" (see WNUM_GAP attribute for settings list)</li> <li>■ 2's +4's bits = 00 default wire number above wire</li> <li>■ 01 = below wire</li> </ul>

### Layer names

<b>TAG_LAY</b>	component tag layer
<b>TAGFIXED_LAY</b>	fixed component tag layer
<b>DESC_LAY</b>	description layer of the parent component
<b>CDESC_LAY</b>	description layer of the child component

<b>TERM_LAY</b>	component terminal pin numbers layer
<b>XREF_LAY</b>	cross-reference layer of the parent component
<b>CXREF_LAY</b>	cross-reference layer of the child component
<b>LOC_LAY</b>	component location code layer
<b>POS_LAY</b>	component position code layer
<b>MISC_LAY</b>	miscellaneous layer
<b>COMP_LAY</b>	layer for schematic component graphics
<b>LINK_LAY</b>	dashed link lines layer
<b>LOCBOX_LAY</b>	location box layer
<b>WIRELAYS</b>	valid wire layer names where "" = all valid (comma-delimited)
<b>WIRENO_LAY</b>	valid wire number
<b>WIRECOPY_LAY</b>	extra wire number layer
<b>WIREFIXED_LAY</b>	fixed wire layer
<b>WIREREF_LAY</b>	terminal and signal arrow wire number layer

### **Fan In/Out**

<b>FAN_INOUT_LAYS</b>	valid layer names for Fan In/Out, single-line wires (comma-delimited)
<b>FAN_INOUT_STYLE</b>	Fan In/Out symbol style number

### **Cross-reference**

<b>XREFFMT</b>	cross-reference format specifier (default=%N)
<b>ALT_XREFFMT</b>	optional cross-reference format for inter-drawing references (that is, %S-%N)

<b>XREF_STYLE</b>	cross-reference style: 0 = text, 1 = graphical, 2 = table
<b>XREF_FLAGS</b>	1's bit = include unused contacts, 2's bit (if table)= include parent coil
<b>XREF_UNUSEDSTYLE</b>	0 = separate reference, 1 = contact count totals
<b>XREF_FILLWITH</b>	cross-reference fill-with text
<b>XREF_SORT</b>	0 = sort by line reference, 1 = sort by pin list
<b>XREF_TXTBTWN</b>	cross-reference text between references (text style cross-referencing)
<b>XREF_GRAPHIC</b>	0 = contact mapping (text), 1 = graphic
<b>XREF_GRAPHICSTYLE</b>	0 = JIC, 1 = IEC
<b>XREF_CONTACTMAP</b>	contact mapping list
<b>XREF_TBLSTYLE</b>	table style name
<b>XREF_TBLTITLE</b>	table title
<b>XREF_TBLINDEX</b>	table fields to include
<b>XREF_TBLFLDNAMS</b>	table available field names
<b>XREF_TBLCOLJUST</b>	table fields justification

### **Referencing**

<b>DATUMX</b>	X coordinate origin for X-Y or X-zone
<b>DATUMY</b>	Y coordinate origin for X-Y or X-zone
<b>DISTH</b>	horizontal interval spacing for X-Y or X-zone
<b>DISTV</b>	vertical interval spacing for X-Y referencing
<b>CHAR_H</b>	horizontal starting character for X-Y or X-zone
<b>CHAR_V</b>	vertical starting character for X-Y referencing



<b>HOIRZ_FIRST</b>	X-Y referencing format: 0 = V-H, 1 = H-V
<b>XY_DELIM</b>	X-Y delimiter character

### Styles

<b>PLC_STYLE</b>	PLC module style code (default = 1)
<b>ARROW_STYLE</b>	default signal arrow style number

### Miscellaneous

<b>WNUM_GAP</b>	list of 3 in line wire number/label gap settings (see WNUM_FLAGS bit 1 for toggle mode); value saved to GBL_wd_inline_gapas a list. nil or "(num1 num2 num3)"
<b>MISC_FLAGS</b>	<p>miscellaneous flags</p> <ul style="list-style-type: none"> <li>■ 0 = gap</li> <li>■ 1 = loop</li> <li>■ 2 = no gap</li> <li>■ 1's bit = mm full-size</li> <li>■ 2's bit = ignore non lay0 lay vector</li> <li>■ 4's bit = use plc wire numbers</li> <li>■ 8's bit = insert new ladders without references</li> <li>■ 16's bit = search for PLC address on component insert</li> <li>■ 32+64 bit = <ul style="list-style-type: none"> <li>■ 10 = none</li> <li>■ 01 = angle 1</li> <li>■ 11 = angle 2</li> <li>■ 00 = dot</li> </ul> </li> </ul>

## Change the WD\_M block

You can change the WD\_M block so that your settings are always the default.

- 1 Open an existing AutoCAD Electrical drawing and set the properties and layer names.

2 Save the drawing.

3 Click Project tab ► Other Tools panel ►  ► Update Symbol



Library WD\_M Block.

4 Select the WD\_M - schematic settings to modify and click OK.  
The settings and layer names are collected from the drawing and appropriate adjustments are made to the WD\_M block.

5 Save the modified WD\_M drawing.

---

**NOTE** Update the version of your template drawing of the inserted WD\_M block if a template drawing exists for your project.

---

6 Open your template file.

7 Click Project tab ► Other Tools panel ►  ► Update to New



WD\_M Block, Values, Layers.

The new version of the WD\_M block replaces your existing one.

## Add missing attributes to the WD\_M block

As AutoCAD Electrical adds new features, new attributes are sometimes added to the default WD\_M block. However, if your drawing was created with an older WD\_M block it may not carry these attributes. AutoCAD Electrical provides an easy way to swap older WD\_M blocks with the new WD\_M block.

1 Select Project tab ► Other Tools panel. Select one of the following options:

**Update to New WD\_M Block, Values, Layers**

Replaces the schematic wd\_m.dwg block in the current drawing with a newer copy, and converts to the newer configuration values and layers.

<b>Update to New WD_M Block, No Changes</b>	Replaces the schematic wd_m.dwg block in the current drawing with a newer copy, but keeps existing configuration values and layer names.
<b>Update to New WD_PNLM Block, Values, Layers</b>	Replaces the panel wd_pnlm.dwg block in the current drawing with a newer copy, and converts to the newer configuration values and layers.
<b>Update to New WD_PNLM Block, No Changes</b>	Replaces the panel wd_pnlm.dwg block in the current drawing with a newer copy, but keeps existing configuration values and layer names.

- 2 Select the WD\_M drawing to use as the new WD\_M block in the drawing.
- 3 Click Open.

## Copy active drawing settings to

Writes the attribute settings for the wd\_m block in the current drawing to the wd\_m.dwg drawing file in the symbol library.

 **Ribbon:** Project tab > Other Tools panel >  > Update Symbol



Library WD\_M Block.

 **Menu:** Projects > Swap WD\_M or WD\_PNLM Blocks > Update Symbol  
Library WD\_M Block

 **Command entry:** AECOPY2SYMLIB

The WD\_M and WD\_PNLM blocks carry attribute values that define the default AutoCAD Electrical settings.

**WD\_M** Defines the default schematic settings.

**WD\_PNLM** Defines the default panel settings.

## Alert

A drawing needs an invisible block, WD\_M.dwg, on the drawing to be compatible with AutoCAD Electrical.

The WD\_M.dwg block is located in the default symbol library. This block carries about 50 attributes that define settings, layer names, and other default settings that are referenced by AutoCAD Electrical commands.

---

**NOTE** If the drawing includes panel layout symbols, the block WD\_PNLM.dwg is also needed. The WD\_M and WD\_PNLM blocks can be present on the same drawing.

---

To insert a WD\_M or WD\_PNLM block

- If the WD\_M block is not present in a new or existing drawing, click OK to insert the block at location 0,0.
- If the WD\_PNLM block is not present in a new or existing drawing when using panel layout symbols, click OK to insert the block.
- To force the drawing settings to match the project settings, select the check box.

## Using Layers

### Manage layers

#### Manage layers

AutoCAD Electrical provides tools for managing and renaming panel and schematic layers. You can use your own layer naming convention with AutoCAD Electrical, as well as change the layer naming used on an existing AutoCAD Electrical drawing using the following tools.

#### Manage panel layers

- 1 Click Panel tab ► Other Tools panel ► Panel Configuration drop-down



- Configuration.
- 2 Click Layers Setup.
- 3 Specify information for the panel component layers, non-text graphic layers, and nameplate layers.

When AutoCAD Electrical inserts a footprint, it is modified on the fly to match the layering scheme set up in this dialog box.

- 4 Click OK.

### Rename panel layers

The Rename Panel Layers tool makes it easy to rename layers one by one, or multiple layers at once by using the Find/Replace method. The advantage to using the AutoCAD Electrical layer rename is that in addition to renaming the layer, AutoCAD Electrical also updates the AutoCAD Electrical layer assignment information carried on the WD\_PNLM block of the drawing. For example, if DEMO-PNPG is currently assigned as the Name Plate graphics layer and you rename it to PNPG using the AutoCAD Electrical rename layer utility, the new layer name is substituted for DEMO-PNP in the AutoCAD Electrical Panel layer name list.

- 1 Click Panel tab ► Other Tools panel ► Panel Configuration drop-down



- Rename Layers .

- 2 To edit an individual layer name, select the layer to edit from the list and click Edit. Enter a new layer name and click OK.
- 3 To edit multiple layer names, click Find/Replace. Enter the text to find and the text to replace it with in the edit boxes. Click OK.

### Manage schematic layers

- 1 Click Schematic tab ► Other Tools panel ► Drawing Properties



drop-down ► Drawing Properties.

- 2 In the Drawing Properties dialog box, click the Drawing Format tab.
- 3 In the Layers section, click Define.
- 4 In the Define Layers dialog box, specify information for the component layers and wire number layers.

The layer names you choose are what AutoCAD Electrical uses as it inserts the parts and pieces of component symbols and wire numbers. If the layer name you enter does not exist when it comes time for AutoCAD

Electrical to insert something onto that layer, AutoCAD Electrical creates that layer on the fly.

- 5 Click OK.
- 6 In the Drawing Properties dialog box, click OK.

---

**NOTE** You can also change layer properties using the Project Manager tool. In the Project Manager, right-click on the drawing name and select Properties ► Drawing Properties (or to change the project default settings, right-click on the project name and select Properties. The settings are applied to new drawings). In the Drawing Format tab, Layers section, click Define.

---

### Rename schematic layers

The Rename Schematic Layers tool makes it easy to rename layers one by one, or multiple layers at once by using the Find/Replace method.

- 1 Click Schematic tab ► Other Tools panel ► Drawing Properties



drop-down ► Rename Layers.

- 2 To edit an individual layer name, select the layer to edit from the list and click Edit. Enter a new layer name and click OK.
- 3 To edit multiple layer names, click Find/Replace. Enter the text to find and the text to replace it with in the edit boxes. Click OK.

---

**NOTE** You can also change layer properties using the Project Manager tool. In the Project Manager, right-click on the drawing name and select Properties ► Drawing Properties (or to change the project default settings, right-click on the project name and select Properties. The settings are applied to new drawings). In the Drawing Format tab, Layers section, click Define.

---

### Define layers

AutoCAD Electrical automatically manages the wire number and component layers you set up in the drawing settings. No matter which layer is active, wires always go to a wire layer and components go to component layers.

 **Ribbon:** Schematic tab ► Other Tools panel ► Drawing Properties

drop-down ► Drawing Properties.



 **Toolbar:** Main Electrical 2

 **Menu:** Projects ► Drawing Properties

 **Command entry:** AEPROPERTIES



In the Drawing Properties dialog box, click the Drawing Format tab. In the Layers section, click Define.

---

**NOTE** You can also change layer properties using the Project Manager tool. In the Project Manager, right-click the drawing name, and select Properties ► Drawing Properties. (To change the project default settings, right-click the project name, and select Properties. The settings are applied to new drawings). In the Drawing Format tab, Layers section, click Define.

---

The layer names you choose are what AutoCAD Electrical uses as it inserts the parts and pieces of component symbols and wire numbers. It does not matter what layer is current at the time. If the layer name you enter does not exist when it comes time for AutoCAD Electrical to insert something onto that layer, AutoCAD Electrical creates that layer on the fly.

### Component Block Layers

Displays layer names. Type layer names into the edit boxes. A blank entry inserts that category on the current layer. Multiple categories can be tied to the same layer name (enter the same layer name into multiple edit boxes).

When a schematic component is inserted, the graphics of the block are inserted onto the layer listed in the Non text Graphics box. The attribute text of the block is automatically moved to the layers listed in the other boxes, based upon attribute function.

<b>Non-text Graphics</b>	Layer name for all non-attribute graphics of a symbol
<b>Component Tags</b>	Layer name for all parent and child component name tags (for example, "CR101")
<b>Fixed Tags</b>	Layer name for component tags that are fixed and are not changed if processed by the retag command

<b>Description</b>	Layer name for parent functional description text (for example, "MASTER RELAY")
<b>Description (Child)</b>	Layer name for child contact functional description text (a copy of the description of the parent)
<b>Cross-reference</b>	Layer name for parent cross-reference text
<b>Cross-reference (Child)</b>	Layer name for child cross-reference text
<b>Pin Numbers</b>	Layer name for terminal pin number text
<b>Installation/Location</b>	Layer name for optional location and installation code text
<b>Positions</b>	Layer name for switch position text
<b>Miscellaneous Text</b>	Layer name for all other component annotation
<b>Dashed Link Lines</b>	Layer name for dashed lines that can be inserted to show multiple components linked together
<b>Location Box</b>	Layer name for Location Boxes
<b>Freeze</b>	If a given layer name exists, use this switch (Freeze/Thaw) to hide (freeze) all attributes on that layer. For example, to hide all child cross-reference text, select Freeze next to the Cross-reference (child) edit box. You can also use the AutoCAD LAYER command to do the same thing.
<b>Apply to entities on layer "0" only</b>	As AutoCAD Electrical inserts a component, it moves the parts and pieces of the symbol to the category layers listed in this dialog box. If you do not want an attribute or the graphics of a specific electrical symbol block to move to the defined AutoCAD Electrical layers, create your symbol with the entities on some layer other than 0, and then select this switch.

### **Wire Number Layers**

Displays wire number layers.

<b>Wire Numbers</b>	Layer name for normal wire numbers
---------------------	------------------------------------



<b>Wire Copies</b>	Layer name for extra wire number copies
<b>Fixed Numbers</b>	Layer name for fixed wire numbers that do not change when other wires are renumbered
<b>Terminal/Signal</b>	Layer name for wire number copies that are part of a terminal or signal arrow symbol

If your current layer is BORDER, when you use the AutoCAD Electrical icon menu to insert a 2-position selector switch. The lines and circles of the switch symbol automatically go to layer SYMS, the tag of the component to layer TAGS, the description text to DESC, switch position text to POS, and soon. If a new wire number inserts as a result of the switch breaking an existing numbered wire, the wire number automatically goes to layer WIRENO. All of this happens automatically, while your layer BORDER is current.

## Rename schematic or panel layers

Renames schematic-related layers and updates schematic drawing layer properties.

### Rename Panel Layers

**Ribbon:** Panel tab ► Other Tools panel ► Panel Configuration

drop-down ► Rename Layers.



**Toolbar:** Panel Miscellaneous

**Menu:** Panel Layout ► Miscellaneous Panel Tools ► Rename Panel Layers

**Command entry:** AERENAMEPANLELLAYER

### Rename Schematic Layers

**Ribbon:** Schematic tab ► Other Tools panel ► Drawing Properties

drop-down ► Rename Layers.



**Toolbar:** Drawing Properties

 **Menu:** Projects ► Rename Schematic Layers

 **Command entry:** AERENAMELAYER

The Layer Rename and Panel Layer Rename utilities rename layers one by one, or multiple layers at once by using the Find/Replace method. Updates the AutoCAD Electrical layer assignment information carried on the WD\_M and WD\_PNLM blocks in the drawing. For example, if DEMO-WIRES is currently assigned as an AutoCAD Electrical wire layer, and you rename it using this utility, the new layer name is substituted for DEMO-WIRES in the AutoCAD Electrical wire layer name list.

<b>Layer Name</b>	Lists the drawing layer names referenced in either the Drawing Properties dialog box or the Panel Layout Configuration dialog box.
<b>Find/Replace</b>	Replaces a name or substring within a layer name.
<b>Edit</b>	Edits the selected layer name.

## Panel component layers

Sets the panel component layers, non-text graphic layers, and nameplate layers. When AutoCAD Electrical inserts a footprint, it is modified on the fly to match the layering scheme set up in this dialog box.

 **Ribbon:** Panel tab ► Other Tools panel ► Panel Configuration

drop-down ► Configuration.



 **Toolbar:** Panel Layout

 **Menu:** Panel Layout ► Panel Configuration

 **Command entry:** AEPANELCONFIG

Click the Layers Setup button.

<b>Panel Component Layers</b>	Lists all of the component layers. Change the layer name for a tag by entering a new name in the edit box. If you do not want an attribute moved to a PNL layer, place that attribute on some other layer than "0" on the block. Then, click the Ignore above for symbol's non-layer "0" entities toggle.
-------------------------------	---

**Non-text Graphic Layers**

When a panel component is inserted, the block is inserted on the current layer if it is one of those listed in the "Non-text Graphics" layer list (wild-cards allowed). If the current layer is not in this list, the block is inserted on the first layer in the list. Attributes are moved to the layer defined for its type.

**Nameplate Layers**

Lists existing nameplate layers for the graphics, tags, and descriptions.

**F**

(Available if a layer exists already) Freezes or thaws any of the panel layers.

**Find/Replace**

Performs a global find and replace on the layer names.

## Use wire layers

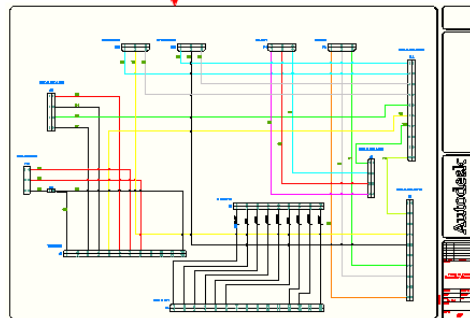
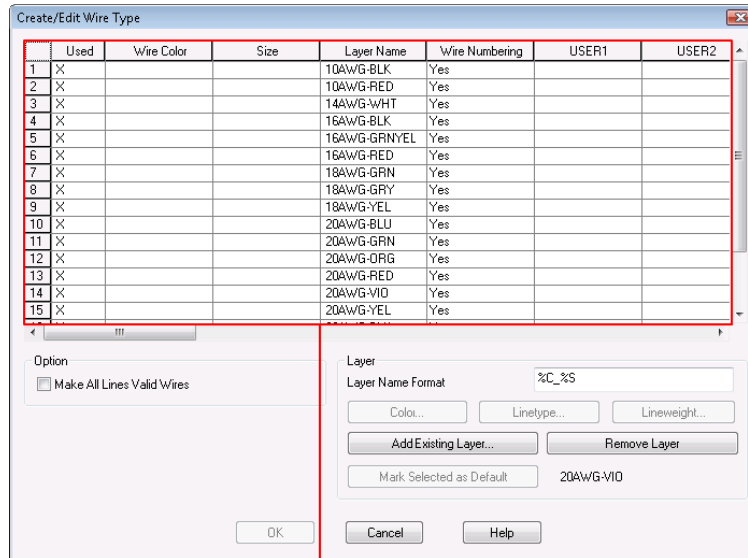

The Set Wire Type tool is used for setting a wire type for new wires only. The wire layer name and the associated wire properties (such as wire color, size, and whether the wire layer is processed for wire numbers) are saved in the drawing file. The following rules determine the wire layer for a new wire:

- When a wire is created from an existing wire, the new wire takes on the same layer as the existing wire. It ignores the current layer and the current wire type.

- When the new wire is started in empty space but ends at an existing wire, the new wire takes on the wire layer of the ending wire. The current layer and current wire type are ignored.
- When a new wire is started at an existing wire and ends at another existing wire, the new wire takes on the layer of the beginning wire.
- If there are no wire layers in the drawing, the new wire is drawn in the WIRES layer.
- When a wire starts in empty space and ends at the component wire connection point, the new wire is drawn on the current wire type. The layer of the wires already tied to the same component connection points are ignored. The same is true for a wire that starts at the component wire connection point and ends in empty space.

Use the Create/Edit Wire Type tool to create new or edit existing wire types or use the Change/Convert Wire Type tool to convert lines to wires.

## Create wire types

Wire types for drawings are set up in the Create/Edit Wire Type dialog box.

- 1 Click Schematic tab ► Edit Wires/Wire Numbers panel ► Modify Wire



Type drop-down ► Create/Edit Wire Type.

- 2 In the Create/Edit Wire Type dialog box, click inside the Wire Color column for a blank row and specify a value for the new wire layer.
- 3 Click inside the Size column and specify a value for the size.  
The Layer Name is automatically created. If you specified Wire Color: Red and Size: 20, the name RED\_20 is assigned to the wire layer you are creating.
- 4 If you do not want wires on this layer processed for wire numbers, select No for the Wire Numbering option.
- 5 To import wire types from an existing drawing or template, click Import.
  - Select the drawing or drawing template containing the wire types for import.
  - On the Import Wire Types dialog box, select the wire types for import.

- Define how the import function behaves if a wire type exists on the active drawing.
- 6 Click Color, Linetype, or Lineweight to assign values for the new layer.
- 
- NOTE** If you want the new wire layer to be the default, click Mark Selected as Default.
- 
- 7 Click OK.

## Add existing wire layers to the drawing

Wire layer names for drawings are set up in the Create/Edit Wire Type dialog box.

- 1 Click Schematic tab ► Edit Wires/Wire Numbers panel ► Modify Wire



Type drop-down ► Create/Edit Wire Type.

- 2 In the Create/Edit Wire Type dialog box, click Add Existing Layer.
- 3 In the Layers for Line "Wires" dialog box, define the layer name and click OK. You can either enter a name in the edit box or click Pick to select a name from the existing layer list.

The layer displays in the wire type grid. If you selected the wrong wire layer, highlight the layer in the dialog box and click Remove Layer. You can then go back into the Layers for Line "Wires" dialog box and select another layer to add.
- 4 In the Create/Edit dialog box, click Color, Linetype, or Lineweight to assign new values for the layer.
- 5 If you do not want wires on this layer processed for wire numbers, select No for the Wire Numbering option.
- 6 Click OK.

## Create/edit wire type

Defines and edits wire types.

 **Ribbon:** Schematic tab ► Edit Wires/Wire Numbers panel ► Modify

Wire Type drop-down ► Create/Edit Wire Type.



 **Toolbar:** Wires



 **Menu:** Wires ► Create/Edit Wire Type

 **Command entry:** AEWIRETYPE

The program saves the wire layer name and associated properties, such as wire color, size, and whether the wire layer is processed for wire numbers, in the drawing file. Use the grid control to sort and select wire types to modify.

---

**TIP** Use the Change/Convert Wire Type tool to convert lines to wires. You can also type "T" at the command prompt during wire insertion to use the Set Wire Type tool.

---

### Wire type grid

Displays the wire types used in the active drawing. The wire layer name and the wire properties like color, size, whether the wire layer is processed for wire numbers, and user-defined properties are listed in the grid. An "x" in the Used column indicates that the layer name is currently used in the drawing. A blank value in this column indicates that the layer name exists in the drawing but it is not currently being used. The current wire type is highlighted with a gray background; selected wire types highlight in blue.

If you do not want wire numbers assigned to wires on a specific layer, select "No" Wire Numbering for that layer. The Insert Wire Numbers command follows these rules:

- If **all** wires in the network are on layers set "No" for Wire Numbering, no new wire number is inserted.
- If **any** wire in the network is on a layer set "Yes" for Wire Numbering, the existing non-fixed wire number is updated or a new wire number is inserted.
- If a wire network already has a non-fixed wire number, it is updated regardless of the Wire Numbering setting. Use the Delete Wire Numbers command to remove the wire number.

---

**NOTE** Manually maintain wire layer type consistency through signal arrows.

---

To rename the User1- User 20 column headers, right-click the project name in the Project Manager and select Properties. In the Project Properties ► Wire Numbers dialog box, Wire Type section, click Rename User Columns. In the Rename User Columns dialog box, specify a new column name and click OK. Renaming of user-defined columns is project-specific. You cannot rename the Color, Size, or Layer Name columns. All the data corresponding to the header column can be copied, cut, and pasted to another column.

All text fields are editable except for the Layer Name cell. It cannot be edited for existing layers. Left-click to edit the cell or right-click in a cell to display options for modifying the cell contents. If you want to rename a layer, right-click on a cell and select Rename Layer. Right-click options include: Copy, Cut, Paste, Delete Layer, and Rename Layer. If it is the default layer, you cannot delete or remove the layer.

You can select multiple layers to edit or remove by using the Shift or Ctrl keys on your keyboard while picking the wire layer in the wire type list.

You can move the wire type records inside the grid to whatever position you want using drag and drop. Select the wire type records to move and drag to the new position in the grid.

### Option

#### Make All Lines Valid Wires

Makes all existing layers valid wire layers and displays them in the wire type grid.

If you later decide you want some layers to be wire layers and others to be line layers, you can deselect this option. All the layers are removed from the wire type grid. Add layers again using the Add Existing Layer option.

#### Import

Imports wire types from an existing drawing or drawing template. Once the drawing is specified, the [Import Wire Types](#) on page 903 dialog box displays. Select the wire types to import.

### Layer

Allows you to format the layer name, define or edit the layer color, linetype, and line weight.

#### Layer Name Format

Format the layer name. The program fills the layer name automatically once you enter a value in color, size based on the format. For example, if you enter



BLK for color and 10AWG for size, the layer name is filled in as BLK\_10AWG based on default %C\_%S format. Placeholders are supported at any place in the format (that is, "CUST%C-THIN%S).

Valid wire name format codes are:

- %C = Wire Color
- %S = Wire Size
- %1-%5 = User 1 - User 5

### Color

Displays the AutoCAD dialog box for Layer colors election. The Select Color dialog box highlights the color corresponding to the wire type record. The default color for new records is white. Undefined colors for layers use the default color while creating the layer. Multiple selection is allowed. All wire layers that were selected can be changed to the color.

### Linetype

Displays the AutoCAD dialog box for linetype selection. This Select Linetype dialog box highlights the linetype corresponding to the wire type record. The default linetype for new records is continuous. Undefined linetypes for layers use the default linetype while creating the layer. Multiple selection is allowed. All wire layers that were selected can be changed to the desired linetype.

---

**NOTE** If you need special linetypes for constructing P&ID or point to point diagrams, load the special linetypes from theacad.lin text file.

---

### Lineweight

Displays the AutoCAD dialog box for lineweight selection. The Lineweight dialog box highlights the lineweight corresponding to the wire type record. The default lineweight for new records is default. Undefined lineweights for layers use the default lineweight while creating the layer. Multiple selection is allowed. All wire layers that were selected can be changed to the desired lineweight.

### Add Existing Layer

Displays the Layers for Line Wires dialog box for specifying a layer name. Click Pick to select the layer

name from the existing layer list consisting of all the layers in the drawing inclusive of the non-wire layers. Only lines on pre-selected layers are processed as wires. Enter a wire layer name in the dialog box. A wildcard used in the name selects a group of layers (for example, RED\_\* selects all layers that begin with "RED\_").

#### Remove Layer

Removes the selected layer name from the wire type grid. The layer is no longer a valid wire layer, however the layer remains in the drawing as an AutoCAD line layer.

If multiple layers of one color exist in the drawing, select all layers of that color in the wire type grid to activate this button. For example, if there are multiple RED\* layers such as RED\_AWG18, RED\_AWG20, and RED\_AWG25, select all three layers in the wire type grid to enable the button.

---

**NOTE** You cannot remove the wire layer marked as the default.

---

#### Mark Selected as Default

Makes the selected layer the default layer for new wire layers and displays the layer name in the dialog box.

#### OK

---

**NOTE** This option is available only when one wire type record is selected in the list.

---

Makes the selected wire type the current wire type. If the selected wire type does not exist on the drawing, the wire layer is created on the fly. The wire layer name and properties are saved in the drawing file. For the layer to create, the following rules apply:

- The layer name must be unique
- The layer name cannot be left blank
- The layer name cannot contain special characters such as / \ " : ; ? \* | , = ' > <

## Import wire types

- 1 Click Schematic tab ► Edit Wires/Wire Numbers panel ► Modify Wire



Type drop-down ► Create/Edit Wire Type.

- 2 Click Import.  
The Wire Type Import - Select Master Drawing dialog box displays.
- 3 Select the drawing or drawing template containing the wire types for import.
- 4 Click Open.  
The Import Wire Types dialog box displays.
- 5 Select the wire types for import.
- 6 Define how the import function behaves if a wire type exists on the active drawing.

**Overwrite any Wire Numbering and USERn differences** - if checked, changes the wire numbering setting and all the USER values for the existing wire type to match the imported wire type.

**Update any layer color and linetype differences** - if checked, changes the color and linetype settings for the existing wire layer to match the imported wire layer.

- 7 Click OK.  
The selected wire types and settings display in the Create/Edit Wire Type dialog.
- 8 Continue adding, importing, and editing wire types in the Create/Edit Wire Type dialog.
- 9 Click OK.

## Import wire types project-wide



- 1 Click Project tab ► Project Tools panel ► Utilities.
- 2 Select the Import from specified drawing check box.

- 3 Browse to or enter the name of the drawing or drawing template containing the wire type definitions for import.
- 4 Click Setup to display the Import Wire Types dialog box.
- 5 Select the wire types for import.
- 6 Define how the import function behaves if a wire type exists on the drawing being processed.
  - Overwrite any Wire Numbering and USERn differences** - if checked, changes the wire numbering setting and all the USER values for the existing wire type to match the imported wire type.
  - Update any layer color and linetype differences** - if checked, changes the color and linetype settings for the existing wire layer to match the imported wire layer.
- 7 Click OK and return to the Project-Wide Utilities dialog box.
- 8 Click OK.  
The Select Drawings to Process dialog box displays.
- 9 Select the drawings you want to import the selected wire types into.
- 10 Click OK.

Imports wire types from another drawing or drawing template.

### Create/Edit Wire Type

 **Ribbon:** Schematic tab ► Edit Wires/Wire Numbers panel ► Modify

Wire Type drop-down ► Create/Edit Wire Type.

 **Toolbar:** Wires

 **Menu:** Wires ► Create/Edit Wire Type

 **Command entry:** AEWIRETYPE

Click the Import button in the Option section.

## Project-wide utilities

 **Ribbon:** Project tab ► Project Tools panel ► Utilities.



 **Toolbar:** Project



 **Menu:** Projects ► Project-Wide Utilities

 **Command entry:** AEUTILITIES

Select the Import from specified drawing check box. Browse to or enter the name of the drawing or drawing template containing the wire type definitions for import. Click Setup.

Double click a column heading to sort the wire type list by the data in that column.

<b>Grid</b>	Select the wire types to import.
<b>Clear All</b> <b>Select All</b>	All wire types are initially selected to import. Clears or selects all wire types to import. <hr/> <b>NOTE</b> The button switches between Select All and Clear All each time it is clicked. <hr/>
<b>Overwrite any Wire Numbering and USERn differences</b>	If checked, changes the wire numbering setting and all the USER values for the existing wire type to match the imported wire type.
<b>Update any layer color and linetype differences</b>	If checked, changes the color and linetype settings for the existing wire layer to match the imported wire layer.

## Change wire types

### Change wire types

You can change the wire type using the Change/Convert Wire Type tool or by typing a "T" at the command prompt during wire insertion commands.

- 1 Click Schematic tab ► Edit Wires/Wire Numbers panel ► Modify Wire



Type drop-down ► Change/Convert Wire Type.

Optionally, you can right-click on an existing wire and select Change/Convert Wire Type.

- 2 In the Change/Convert Wire Type dialog box, select a wire type record in the wire type list, or click Pick to select a wire type record from the drawing.

If you right-clicked on a wire and selected Change/Convert Wire Type, the wire type corresponding to the selected wire layer is highlighted in the list.

- 3 Make any selections in the dialog box.

If Change all wires in the wire network is selected, all wires in the wire network are changed to the new wire type. If unselected, only the selected wire is changed.

If Convert Lines to Wires is selected, the selected lines are changed to the new wire type. If unselected, the lines are ignored.

- 4 Click OK.
- 5 Select the wires or lines in the drawing to change and press Enter.

### Override wire type at command prompt

During wire insertion, the current wire type displays at the command prompt. You can override the wire type by typing in the hot key "T" and selecting a new wire type from the Set Wire Type dialog box. The new wire type becomes the current wire type and the command continues with the wire insertion. Use the following commands:

- Click Schematic tab ► Insert Wires/Wire Numbers panel ► Insert Wires drop-down ► Wire.
- Click Schematic tab ► Insert Wires/Wire Numbers panel ► Insert Wires drop-down ► 22.5 Degree.
- Click Schematic tab ► Insert Wires/Wire Numbers panel ► Insert Wires drop-down ► 45 Degree.
- Click Schematic tab ► Insert Wires/Wire Numbers panel ► Insert Wires drop-down ► 67.5 Degree.

- Click Schematic tab ► Insert Wires/Wire Numbers panel ► Multiple Bus.
- Click Schematic tab ► Edit Wires/Wire Numbers panel ► Modify Ladder drop-down ► Add Rung.
- Click Schematic tab ► Insert Wires/Wire Numbers panel ► Insert Ladder drop-down ► Insert Ladder.

---

**NOTE** If you select Another Bus (Multi-Wire) in the Multiple Wire Bus dialog box, the wires are drawn on the same wire layer as the existing wire bus. You cannot type "T" to change the wire type during wire insertion.

---

## Change/convert wire type

Convert lines to wires, or change wires from one wire type to another.

---

**TIP** Use the Create/Edit Wire Type tool to create and edit wire types. You can also type "T" at the command prompt during wire insertion to use the Set Wire Type tool.

---

 **Ribbon:** Schematic tab ► Edit Wires/Wire Numbers panel ► Modify

Wire Type drop-down ► Change/Convert Wire Type.



 **Toolbar:** Wires

 **Menu:** Wires ► Change/Convert Wire Type

 **Command entry:** AECONVERTWIRETYPE

You can also right-click on an existing wire and select Change/Convert Wire Type. Use the grid control to sort and select the wire types for modification.

### Wire type grid

Displays the wire types used in the active drawing. The wire layer name and the wire properties like color, size, whether the wire layer is processed for wire numbers, and user-defined properties are listed in the grid. An 'x' in the Used column indicates that the layer name is currently used in the drawing. A blank value in this column indicates that the layer name exists in the drawing but it is not currently being used.

A “No” in the Wire Numbering column indicates that wires on this layer do not receive a wire number. The Insert Wire Numbers command follows these rules:

- If **all** wires in the network are on layers set “No” for Wire Numbering, no new wire number is inserted.
- If **any** wire in the network is on a layer set “Yes” for Wire Numbering, the existing non-fixed wire number is updated or a new wire number is inserted.
- If a wire network already has a non-fixed wire number, it is updated regardless of the Wire Numbering setting. Use the Delete Wire Numbers command to remove the wire number.

---

**NOTE** Manually maintain wire layer type consistency through signal arrows.

---

To rename the User1- User 20 column headers, right-click the project name in the Project Manager and select Properties. In the Project Properties ► Wire Numbers dialog box, Wire Type section, click Rename User Columns. In the Rename User Columns dialog box, specify a new column name and click OK. Renaming of user-defined columns is project-specific. You cannot rename the Color, Size, or Layer Name columns. All the data corresponding to the header column can be copied, cut, and pasted to another column.

### **Pick**

Allows you to pick a wire or line in the active drawing. Once you pick a wire, the corresponding wire type record is highlighted. If you pick a line in the active drawing, you can add the layer where the line resides to the list of valid wire layers. A new wire type record is created automatically.

### **Change/Convert**

<b>Change All Wire(s) in the Network</b>	Changes all the wires in the wire network to the selected wire type record. If unselected, only a single wire is changed to the selected wire type.
<b>Convert Line(s) to Wire(s)</b>	Changes the lines to the selected wire type in the wire type grid.

### **OK**

---

**NOTE** This option is available only when one wire type record is selected in the list.

---



Makes the selected wire type the current wire type. If the selected wire type does not exist on the drawing, the wire layer is created on the fly. The wire layer name and properties are saved in the drawing file. For the layer to create, the following rules apply:

- The layer name must be unique
- The layer name cannot be left blank
- The layer name cannot contain special characters such as / \ " ; ? \* | , = ' > <

## Set wire type

This tool sets wire types for new wires. Use the grid control to sort and select the wire types for modification.

---

**TIP** Use the Create/Edit Wire Type tool to create and edit wire types or the Change/Convert Wire Type tool to convert lines to wires.

---

Type "T" at the command prompt during wire insertion.

## Wire type grid

Displays the wire types used in the active drawing. The wire layer name and the wire properties like color, size, whether the wire layer is processed for wire numbers, and user-defined properties are listed in the grid. An 'x' in the Used column indicates that the layer name is currently used in the drawing. A blank value in this column indicates that the layer name exists in the drawing but it is not currently being used.

A "No" in the Wire Numbering column indicates that wires on this layer do not receive a wire number. The Insert Wire Numbers command follows these rules:

- If **all** wires in the network are on layers set "No" for Wire Numbering, no new wire number is inserted.
- If **any** wire in the network is on a layer set "Yes" for Wire Numbering, the existing non-fixed wire number is updated or a new wire number is inserted.
- If a wire network already has a non-fixed wire number, it is updated regardless of the Wire Numbering setting. Use the Delete Wire Numbers command to remove the wire number.

---

**NOTE** Manually maintain wire layer type consistency through signal arrows.

---

To rename the User1- User 20 column headers, right-click the project name in the Project Manager and select Properties. In the Project Properties ► Wire Numbers dialog box, Wire Type section, click Rename User Columns. In the Rename User Columns dialog box, specify a new column name and click OK. Renaming of user-defined columns is project-specific. You cannot rename the Color, Size, or Layer Name columns. All the data corresponding to the header column can be copied, cut, and pasted to another column.

### OK

---

**NOTE** This option is available only when one wire type record is selected in the list.

---

Makes the selected wire type the current wire type. If the selected wire type does not exist on the drawing, the wire layer is created on the fly. The wire layer name and properties are saved in the drawing file. For the layer to create, the following rules apply:



- The layer name must be unique.
- The layer name cannot be left blank.
- The layer name cannot contain special characters such as / \ " ; ? \* | , = ' > <.

## Optional ENV file assignment for current project

### Optional ENV file assignment for current project

You can create an alternate environment settings ENV file and assign it to the active project. Customer-specific ENV files can be created to store customer settings, paths, libraries, and menus. For a given project, you can assign the appropriate ENV file to the project. The ENV file name reference is saved in the WDP drawing list file of the project. Whenever the project is selected, the settings in the referenced ENV file are automatically restored.

 **Ribbon:** Project tab ► Project Tools panel ► Manager. 

 **Toolbar:** Main Electrical 2 

 **Menu:** Projects ► Project ► Project Manager

 **Command entry: AEPROJECT**

Right-click the project name and select Settings. On the Current Settings dialog box, click Environment file.



# Symbol Libraries

# 5

## Determine symbol block names

The [symbol folder](#) on page 204 contains hundreds of component symbols in standard AutoCAD ".dwg" file format. They are referenced by AutoCAD Electrical and its icon menuing system and are inserted as standard AutoCAD blocks with attributes. There are two ways to determine the block name of an existing symbol:

### METHOD A

Insert the symbol from the AutoCAD Electrical icon menu and then use the AutoCAD LIST command to display the block name. Add the appropriate library path as a prefix to this block name to obtain the path to the ".dwg" file of the symbol. The default library path is

- **Windows XP:** \Documents and Settings\All Users\Documents\Autodesk\Acade {version}\libs\{library}\
- **Windows Vista, Windows 7:** \Users\Public\Documents\Autodesk\Acade {version}\libs\{library}\

### METHOD B

The [icon menu](#) on page 204 file lists the symbol descriptions and file names of all components referenced in the AutoCAD Electrical icon menuing system. You can pick the symbol names from this file. Here is an example of how the data looks in this file.

"On delay coil | S2(SHTD1N) | HTD1N".

The "|" characters divide the entry into three sections. The first piece is the description that appears in the side bar of the menu, the second in a slide-library reference, and the third is the actual symbol file name. In this example, the file name of the library symbol is htd1n.dwg. The vertical version of this symbol is vtd1n.dwg.

You can select a different name for a component family by creating or editing the WD\_FAM.dat file. For example, to limit switches be tagged "LIM" instead of "LS" and you want pilot lights to be "PL" instead of "LT", you would add the following two lines to the file (or create the file if it does not exist):

```
LS,LIM
```

```
LT,PL
```

The change takes effect when you exit and reload AutoCAD Electrical. New limit switch components you insert receive the "LIM" family code annotation instead of the library default of "LS," and pilot lights are tagged with "PL" instead of "LT." Use the RETAG command to update previously inserted components.

## Library Symbol Naming Conventions

### Overview of symbol naming conventions

AutoCAD Electrical depends on a specific naming convention to enable some of its automation features to work. Though not mandatory, follow the naming convention outlined in the following section if you create new AutoCAD Electrical-smart symbols for use with AutoCAD Electrical. Custom symbols can take full advantage of the AutoCAD Electrical features.

#### Cable Marker Symbols

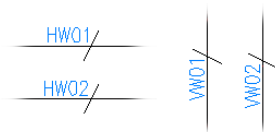

AutoCAD Electrical cable conductor marker symbols follow this convention:

- The first character is "H" or "V" for horizontal wire or vertical wire insertion.

- The next two characters are "W0." A zero (0) means that the symbol does not trigger a wire number change through it.
- The fourth character is either 1 or 2: "1" for parent marker or "2" for child marker.
- The remaining characters are not specified.

**Examples:**

HW01.dwg	Parent cable conductor marker, horizontal wire insertion
HW02.dwg	Child cable marker, horizontal wire insertion
VW01.dwg	Parent cable conductor marker, vertical wire insertion
VW02.dwg	Child cable marker, vertical wire insertion

**Components - General**

Schematic components such as relays, switches, pilot lights, and discrete motor control devices (but not PLC I/O symbols) follow this naming convention:

- 32-character block name maximum, first character is either "H" or "V" for horizontal or vertical wire insertion.
- The next two characters are reserved for family type (for example, PB for push buttons, CR for control relays, LS for limit switches). A zero (0) as the second character of the family type (for example, a 0 in the overall symbol name) means that the symbol does not trigger a wire number change through it. (For example, T0 for terminals, W0 for cable markers, C0 for connectors.)
- The fourth character is generally a 1 or a 2: 2 for child contacts and 1 for everything else (parent or standalone component).
- If the symbol is a contact, then the fifth character is a 1 for normally open, 2 for normally closed.
- The remaining characters are not specified. They are used to keep names unique.

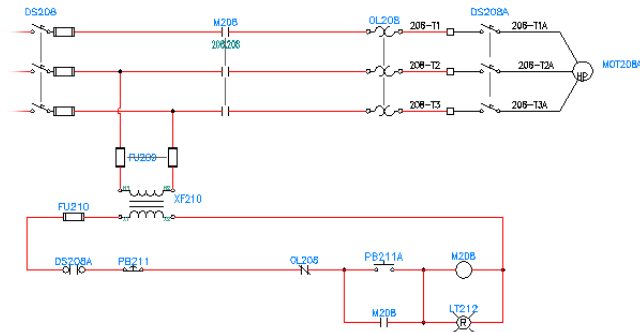

### Examples:

HCR1.dwg	Control relay coil, horizontal rung insertion
VCR1.dwg	Control relay coil, vertical rung insertion
HCR21.dwg	Horizontal relay contact, N.O.
HCR22.dwg	Horizontal relay contact, N.C.
HCR22T.dwg	Horizontal relay contact, N.C., with in-line terminal numbers
VPB11.dwg	Vertical push button, parent contact, N.O.
VPB21.dwg	Vertical push button, child contact, N.O.
HLS11.dwg	Horizontal limit switch, parent, N.O.
HLS11H.dwg	Horizontal limit switch, parent, N.O. Held closed
VLT1RP.dwg	Vertical pilot light, red, press-to-test
HW01.dwg	Horizontal cable marker, no wire number change through it

### Component Location Mark Symbols

AutoCAD Electrical expects the location symbol names to begin with the characters "WDXX."



## Configuration and Ladder Master Line Reference Symbols

AutoCAD Electrical expects to find these block inserts:

WD_M.dwg	Block insert consisting of about 50 invisible attributes. They carry the settings of the drawing.
WD_PNLM.dwg	Optional block insert consisting of several invisible attributes. They carry the settings of the drawing for panel layout functions.
WD_MLRH.dwg	Block insert that carries the first line reference number of a ladder and additional information such as rung spacing and ladder length.
WD_MLRV.dwg	Same as previous symbol, but for a ladder that lies on its side.
WD_MLRHX.dwg	Optional, user-defined alternative to WD_MLRH.dwg. AutoCAD Electrical uses this symbol name when you select 'User Block' from the Line Reference Numbers subdialog box of the Drawing Properties ► Drawing Format dialog box (on the Drawing Properties ► Drawing Format dialog box, Format Referencing section, select Reference Numbers and click Setup).
WD_MLRVX.dwg	Same as previous symbol, but for a ladder that lies on its side.

---

**NOTE** The ladder line reference block used by AutoCAD Electrical is determined by the ladder reference configuration selected in the Format Referencing section of the Drawing Properties ► Drawing Format dialog box.

---

### Connector Symbols

- The first character is "H" or "V" for horizontal or vertical orientation.
- The next two characters are "CN" for connector.
- The fourth character is either 1 or 2: 1 for parent or 2 for child.
- The fifth character is "\_"
- The sixth character is 1-9 for the style number.
- The seventh character:  
(Combo) specifies the plug or jack ID: P = Plug, J = Jack (Receptacle)  
(Only) specifies the wire direction: 1 = right, 2 = top, 4 = left; and 8 = bottom.

- The eighth character is either "P" or "J": P = Plug, J = Jack (Receptacle)

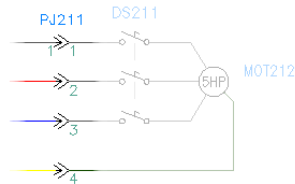

### Examples:

HCN1_14P.dwg	Horizontal parent - single (plug) wiring connects from left or bottom
VCN2_18P.dwg	Vertical child - single (plug) wiring connects from left or bottom
HCN1_11J.dwg	Horizontal parent - single (receptacle) wiring connects from right or top
VCN2_12P.dwg	Vertical child - single (plug) wiring connects from right or top

Upon completion of the parametric build connector, a unique new block definition is created. Each connector is labeled with a unique naming convention within the same project.

HCN1_14P_nnn	Horizontal connector; where "nnn" is a random number for uniqueness
VCN1_18P_nnn	Vertical connector; where "nnn" is a random number for uniqueness

### Hydraulic Symbols

The maximum number of characters for the block name is 32.

- The first character is "H" or "V" for horizontal wire or vertical.
- The next two characters are the first two letters of the family name (for example, FI for filters, CY for cylinders, PM for pumps). See [Overview of Hydraulic and P&ID](#) on page 304 for a list of symbol family names.
- The fourth character is "1" for hydraulic symbols - stand-alone component.

- Use "\_" and enter a meaningful name corresponding to the symbol.

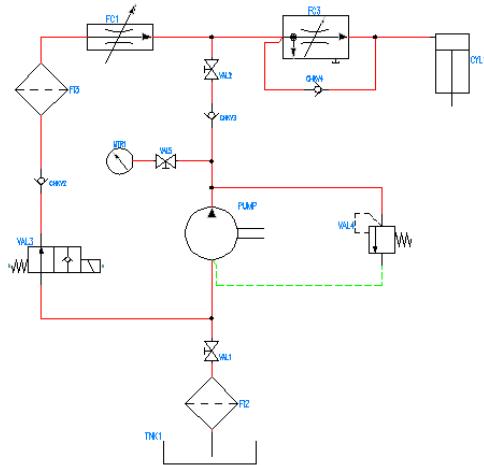

**Example:**

HCYL1\_plunger\_cyl.dwg

Horizontal standalone cylinder; plunger\_cyl is the meaningful name for the symbol

**Inline Wire Marker Symbols**

Construct dumb inline wire marker symbols with a tiny piece of "pigtail" line entity at each connection point. It can be small, but it must be present for AutoCAD Electrical to correctly "see" the in-line inserted block as it traces the wire network. Inline wire marker symbols follow this naming convention:

- The first character is "H" or "V" for horizontal wire or vertical wire insertion.
- The next three characters are "T0\_"
- The remaining characters are undefined.

— GRN —

— 205 —

### Example:

HTO\_RED.dwg

"RED" inline marker, horizontal wire insert

### One-line Symbols

One-line symbols follow the same naming convention as schematic parent and child symbols. To make the symbol names unique, the one-line symbol block names have a "1-" suffix. However, the symbol name does not define the symbol as a one-line symbol. A one-line symbol is defined by the existence of a **WDTYPE** attribute on page 325 with a value of "1-" on the symbol, or a value of "1-1" for a one-line bus-tap symbol.

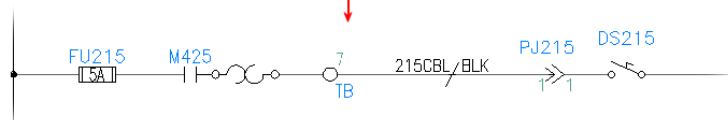
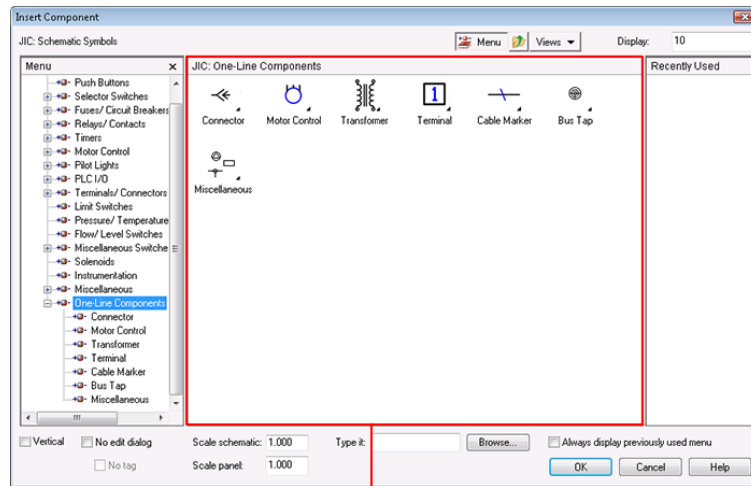

The bus-tap symbol can have two functions:

- Provide an anchor point for the one-line circuit representation that begins at this location.

- Break into the one-line bus where the circuit connects.

On a dual circuit one-line template, there are three bus-tap symbols. One at the normal point where the circuit ties into the bus. There is another version of the symbol on each of the two circuit "legs", each marking the point where that part of the dual circuit starts. These bus-tap symbols allow various reports to report accurately on a one-line circuit, whether a single circuit or a dual circuit representation.

The following bus-tap symbols are supplied:

- HDV1\_BT\_1-.dwg - with "dot" for horizontal one-line circuit
- VDV1\_BT\_1-.dwg - with "dot" for vertical one-line circuit
- HDV1\_BTT\_1-.dwg - "tee" connection for dual horizontal circuit
- VDV1\_BTT\_1-.dwg - "tee" connection for dual vertical circuit
- HDV1\_BTL\_1-.dwg - "corner" connection for dual horizontal circuit
- VDV1\_BTL\_1-.dwg - "corner" connection for dual vertical circuit

---

**NOTE** A WDTYPE attribute with a "1-1" value, identifies a bus-tap symbol.

---

### **P&ID Symbols**

The maximum number of characters for the block name is 32.

- The first character is "H" or "V" for horizontal wire or vertical.
- The next two characters are the first two letters of the family name (for example, GV for diaphragm valves, IN for instruments, N for nozzles). See [Overview of Hydraulic and P&ID symbols](#) on page 304 for a list of symbol family names.
- The fourth character is "1" for P&ID symbols - stand-alone component.
- Use "\_" and enter a meaningful name corresponding to the symbol.

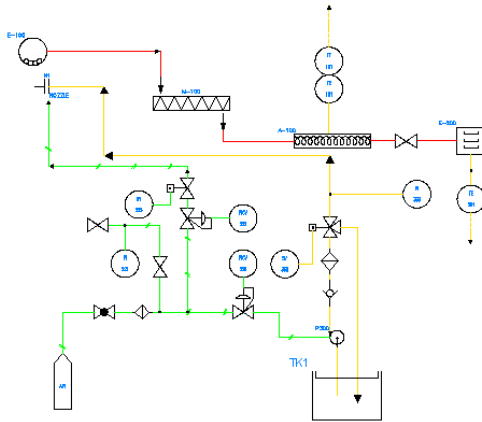

**Example:**

VTK1\_ver\_tank.dwg

Vertical standalone cyclone; ver\_tank is the meaningful name for the symbol

### Panel Layout Footprint Symbols

There is not a required naming convention to follow, but the name must adhere to the AutoCAD 32-character block name limit.

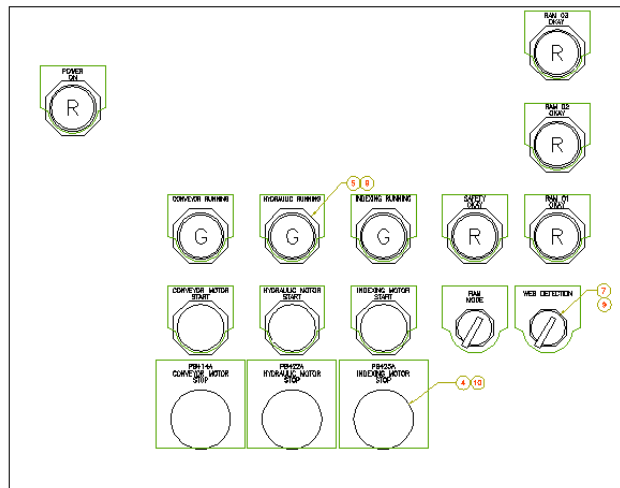

## Parametric Twisted Pair Symbols

A parametrically generated twisted pair representation consists to two instances of the same symbol (there are no parent/child versions). This symbol must carry attribute ACE\_FLAG with a value of "3." Parametric twisted pair symbols follow this naming convention:

- The first four characters are "HTO\_" or "VTO\_" for horizontal or vertical parametric symbols.
- The remaining characters can be anything (default is set to "TW")

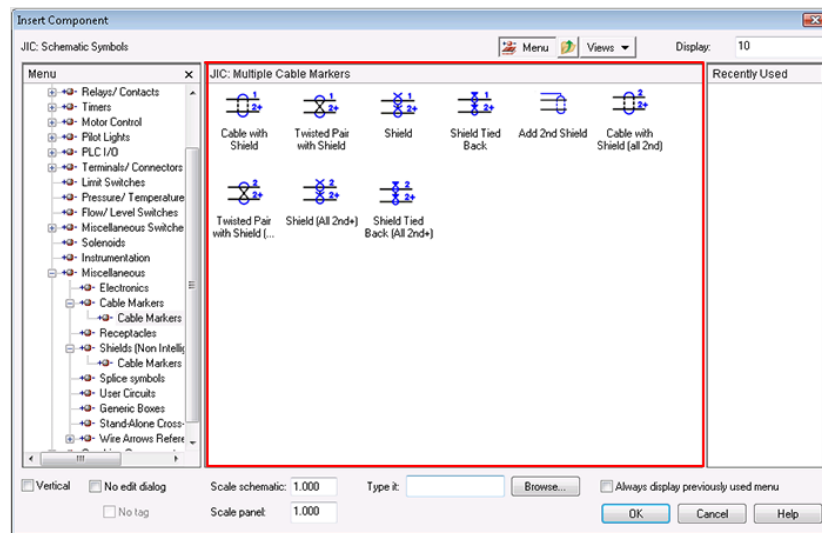

### Examples:

HTO\_TW.dwg                      Horizontal parametric connector symbol

VTO\_TW.dwg                      Vertical parametric connector symbol

## PLC I/O Parametric Build Symbols

These symbols begin with "HP" or "VP" (horizontal rung versus vertical) followed by a digit 1 through 9. The digit corresponds to the selected PLC module style or look. (1 through 5 are provided in the AutoCAD Electrical library, 6 through 9 can be user-defined).

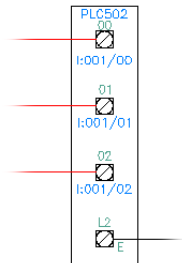

### Plug/Jack Connector Pin Symbols

AutoCAD Electrical connector symbols follow this convention:

- The first character is "H" or "V" for horizontal wire or vertical wire insertion.
- The next two characters are "C0" if the connector does not trigger a wire number change through it. (The "0" means that the wire number does not change, or "CN" if the connector DOES trigger a wire number change.)
- The fourth character is either 1 or 2: 1 for parent marker or a 2 for child marker.
- The remaining characters are not specified.

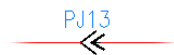

### Splice Symbols

Splices follow this naming convention:

- The first four characters are "HSP1" or "VSP1" for horizontal or vertical splices.
- The fifth through seventh characters are "001", "002", "003," and so on.



### Examples:

HSP1001.dwg

Horizontal splice #1



VSP1001.dwg	Vertical splice #1
HSP1003.dwg	Horizontal splice #3

### Source/Destination Wire Signal Arrow Symbols

AutoCAD Electrical wire signal arrow symbols follow this convention:

- The first four characters of these symbol names are either "HA?S" for source signal arrows or "HA?D" for destination symbol arrows. The "?" character is the arrow style digit (1 through 4 are provided in the AutoCAD Electrical library and 5 through 9 can be user-defined).
- Characters 5 through 11 can be user-defined.

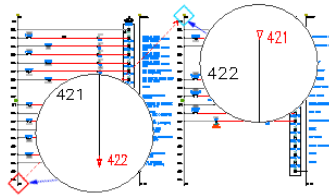

You can create your own arrow styles using these unused digits (for example, HA5S... and HA5D...). For example, copy Autodesk\Acade {version}\Libs\jic1\ha1s\*.dwg to ha5s\*.dwg and Autodesk\Acade {version}\Libs\jic1\ha1d\*.dwg to ha5d\*.dwg. Access each copied arrow symbols in AutoCAD and edit to suit. Then, to access your new arrow style, set the default arrow style to "5" in the Drawing Properties ► Styles dialog box.

### Standalone Cross-reference Symbols:

Same naming convention as the Source/Destination Signal symbols (that is, HA?S\* and HA?D\*) but without a WIRENO attribute present on the symbol.

### Stand-alone PLC I/O Point Symbols

These symbols begin with "PLCIO" and can be up to 32 characters long. There is no naming convention referenced by AutoCAD Electrical other than the "PLCIO" prefix.

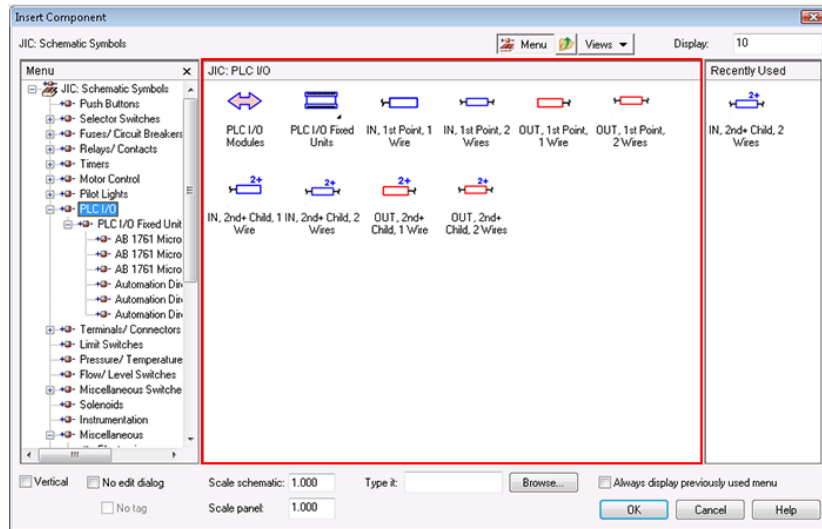

### Examples:

PLCIO50E1761-L16AWA.dwg

AB 1761 model L16-AWA with 0.5 unit rung spacing

PLCIO11T.dwg

Standalone input point, single wire connection

### Standalone Terminal Symbols

Stand-alone terminals follow this naming convention:

- The first two characters are "HT."
- The third character is "0" if the wire number does not change through the terminal, "1" if the terminal symbol should trigger a wire number change.
- The fourth character is an underscore (\_) if the terminal carries no attributes for AutoCAD Electrical to process (such as a dumb, unannotated terminal symbol). Otherwise, the fourth through eighth character positions of the symbol file name are user-defined.

### Examples:

HT0001.dwg

Square terminal with annotation, wire number does not change

HT1001.dwg

Same as previous symbol, but wire number changes through the terminal

**HT0\_01.dwg**                      Dumb, square terminal with no annotation, no wire number change

### **User-defined Symbols**

AutoCAD Electrical user-defined symbols follow this convention:

- The first character is "H" or "V" for horizontal wire or vertical wire insertion.
- The next two characters are "ZA" through "ZZ."
- The remaining characters can be user-defined.

### **Wire Dot Symbols**

AutoCAD Electrical expects this symbol name to be "WDDOT.dwg."

### **Wire Number Symbols**

An AutoCAD Electrical wire number is a block insert consisting of a single wire number attribute. The origin of the block insert lies on its wire with the wire number attribute floating above, below, or off to the side of the insertion point of the block.

#### **Examples:**

<b>WD_WNH.dwg</b>	Wire number for horizontal wire insertion
<b>WD_WNV.dwg</b>	Wire number for vertical wire insertion
<b>WD_WCH.dwg</b>	Extra wire number copy for horizontal wire
<b>WD_WCV.dwg</b>	Extra wire number copy for vertical wire

AutoCAD Electrical also supports inline wire numbers that follow the value of the main wire number. An inline wire marker has a block name that follows that of a terminal symbol that does not trigger a wire number change.

#### **Examples:**

<b>HT0_W1.dwg</b>	Inline wire number marker, horizontal wire insertion, short wire number
<b>HT0_W3.dwg</b>	Inline wire number marker, horizontal wire insertion, longer wire number

VT0_W1.dwg	Inline wire number marker, vertical wire insertion, short wire number
VT0_W2.dwg	Inline wire number, vertical wire insertion, medium wire width, vertical wire insertion

### Family type

The second and third characters of the symbol name are reserved for family type (for example, PB for push buttons, CR for control relays, LS for limit switches). The family type can be used to determine the [catalog lookup table name](#) on page 1265 and the tag name for a component. The library symbols supplied with AutoCAD Electrical use the following family types.

Family Type	Description
AM	Ammeters
AN	Buzzers, horns, bells
BA	Batteries
BV	Ball Valves
C0, CN	Connectors/pins
CA	Capacitors
CB	Circuit breakers
CR	Control relays
DB	Distribution blocks
DI	Diodes
DN	Device networks
DR	Drives
DS	Disconnect switches
DV	Device boxes

<b>Family Type</b>	<b>Description</b>
EN	Enclosures/hardware
FL	Level switches
FM	Frequency meters
FS	Flow sensors
FT	Foot switches
FU	Fuses
GV	Gate valves
LR	Latching relays
LS	Limit switches
LT	Lights, pilot lights
LV	Globe valves
MO	Motors
MS	Motor starters/contactors
OL	Overloads
PB	Push buttons
PC	Pull cord switches
PE	Photo switches
PG	A-plug switches
PM	Power meters
PS	Pressure switches
PW	Power supplies

<b>Family Type</b>	<b>Description</b>
PX	Proximity switches
RE	Resistors
SP	Splices
SS	Selector switches
SU	Surge suppressors
SV	Solenoids
SW, TG	Toggle switches
T0, T1	Terminals
TC	Thermocouples
TD	Timer relays
TS	Temperature switches
VM	Volt meters
VR	Variable resistors
WO	Cables, multi-conductor cables
XF	Transformers

## Split a tag name into two pieces

### Split a tag name into two pieces

TAG1\_PART1, TAG1\_PART2, TAG1\_PARTX (as well as TAG2\_PART1, TAG2\_PART2, TAG2\_PARTX) are alternatives to TAG1 and TAG2 that allow you to split a tag name into two pieces and, for example, position one piece above the other on the symbol. You can create drawings with a mix of both symbols having split tags and other symbols carrying just the single TAG1 or TAG2 attribute.

- 1 Open up the .dwg library symbol drawing that you want to modify.
- 2 Rename the TAG1 attribute definition to read TAG1\_PART1.
- 3 Add a new attribute definition TAG1\_PART2.
- 4 Position both attribute definitions inside of the circle graphics of the symbol (one above the other).

With this setup, AutoCAD Electrical automatically splits tags like CR104 and 104CR into two pieces (where characters split from numbers to letters) and apply the pieces to these attributes.
- 5 For instances where there is a delimiter between the character and number parts of a tag, and you do not want the delimiter to show on one part or the other of the visible tag, add attribute definition TAG1\_PARTX to the library symbol and mark it "invisible".

AutoCAD Electrical stores the delimiter of the split tag in the attribute.

---

**NOTE** If a parent symbol has the single TAG1 attribute, related child symbols can have split tag attributes and vice versa. If a parent symbol has split tag attributes, related child symbols do NOT have to have split tag attributes. The default value character string of the symbol for the tag should be annotated as a default value on the TAG1\_PART1 attribute definition.

---

## Use multiple symbol libraries

You can select the library you want to use for each project. One project might require a JIC-style library, and another an IEC-style library. Each symbol library set must be in its own subdirectory, but adhere to the AutoCAD Electrical file naming convention. You cannot have duplicate symbols in the various symbol libraries.

To set a symbol library to use for a particular project, right-click the project name inside the Project Manager, and select Properties. In the Project Properties

► Project Settings dialog box, click the plus sign (+) next to Schematic Libraries or Panel Footprint Libraries. Click Add and enter the path of the library into the edit box or click Default to use the default libraries.

---

**NOTE** You can include electrical, pneumatic, or other schematic libraries in the path.

---

You can also include a series of library paths for AutoCAD Electrical to use. Enter the names of the libraries (in order) with a semicolon between them. For example:

```
C:/Documents and Settings/All Users/Documents/Autodesk/Acade  
{version}/Libs/;C:/{user path}/{user library}.
```

### **AutoCAD Electrical search sequence**

AutoCAD Electrical runs through specific search sequences when looking for your symbols.

- 1 Looks on the drawing for a copy of the requested symbol.
- 2 Checks for the specific file name if a full path name is provided.
- 3 Checks in your user subdirectory (given by the WD\_USER setting in the .env file).
- 4 Checks in the directory where the active project's .wdp file is located.
- 5 Checks in the selected library -- it is the library selected per the active project.
- 6 Checks the directory containing AutoCAD Electrical support files.
- 7 Checks the current directory.
- 8 Checks the path given by the AutoCAD Electrical environment variable.

### **How to install additional symbol libraries**

During installation, you specified which symbol libraries to install. You can install additional symbol libraries later.

- 1 From the Control Panel select Add or Remove Programs.
- 2 From the Add or Remove Programs dialog box, select the latest version of AutoCAD Electrical and click the Change/Remove button.
- 3 On the AutoCAD Electrical Installation Wizard, click Add or Remove Features.
- 4 On the Add/Remove Features page, click Next.
- 5 On the Manufacturer Content Selection page, click Next.
- 6 On the Select Symbol Libraries page, select the libraries you wish to install and click Next.



- 7 Click Next to continue.

## Set a symbol library as the default

- 1 Exit AutoCAD Electrical.
- 2 Make a back-up copy of your environment (.env) file. To find the full name and path of your environment (.env) file, right-click a project name inside the Project Manager, and select Settings.
- 3 Open the .env file in a text editor such as WordPad.
- 4 Look for a line in the environment file that begins with "WD\_LIB."
- 5 Edit this line to reflect the path of your default library. For example if the path to your new default library is now n:/elec/syms, change the line to read:  
WD\_LIB,n:/elec/syms/,AutoCAD Electrical symbols
- 6 Save and close the file.

Another method is to use an AutoCAD Electrical variable in the WD\_LIB line of the .env file. You could use %ACAD\_SUP\_LAST% or %ACAD\_SUP\_FIRST% to point to the last (or first) path defined in your AutoCAD Options ► Files ► Support file path.

WD\_LIB,%ACAD\_SUP\_LAST%,AutoCAD Electrical symbols

WD\_LIB,%ACAD\_SUP\_FIRST%,AutoCAD Electrical symbols

## Overview of one-line symbols

The one-line symbol library consists of all the one-line symbols and is found under

- **Windows XP:** C:\Documents and Settings\All Users\Documents\Autodesk\Acade {version}\Libs\{library}\1-
- **Windows Vista, Windows 7:** C:\Users\Public\Documents\Autodesk\Acade {version}\Libs\{library}\1-

A one-line symbol can be a parent, child, or terminal. These one-line symbols use the same attributes as the schematic parent, child, and terminal symbols but with the following exceptions.

Attribute	Description
WDTYPE	The attribute must be present and carry a value of "1-" to indicate it is a one-line symbol, or "1-1" for the one-line bus-tap symbols. A bus-tap symbol is used to mark the beginning of a one-line circuit. Schematic symbols do not carry this attribute or have the attribute but with a blank value.
RATING1	Omitted from one-line cable markers symbols since a one-line cable marker can represent multiple conductors, multiple wires, or core color assignments.
TERM01	Omitted from one-line terminal symbols since a one-line terminal can represent multiple independent terminals. If a TERM01 attribute is added to a one-line symbol and carries a non-blank value, it can be edited in the Insert/Edit Terminal Symbol dialog box. However, terminal number text on one-line terminal symbols is not linked back to terminal number assignments on schematic or panel terminal representations.

---

**NOTE** Terminal Strip Editor does not process one-line terminals.

---

One-line symbols follow the same naming convention as schematic parent and child symbols. For convenience, the one-line symbols provided have a "1-" suffix. However, the symbol name does not define the symbol as a one-line symbol. This is defined by the [WDTYPE attribute](#) on page 325 value of "1-" on the symbol, or a "1-1" on a one-line symbol.

- Motor control one-line symbols are accessible from the icon menu.
- Circuit Builder supports building motor control one-line circuits dynamically. It allows the design of one-line circuits, with component values and wire sizes, to conform to a given electrical code.
- One-line component symbols can be related to parent/child counterparts on the schematic and panel layout drawings within a project. It means that they can be Surfed together and update each other when one is modified.

- Tagging of schematic or panel components using existing commands can reference a pick list that includes components pulled from the one-line diagrams.
- Certain component and Bill of Material reports can report only one-line diagram components.

### **Bus-tap symbols**

The bus-tap symbol can have two functions:

- Provide an anchor point for the one-line circuit representation that begins at this location.
- Break into the one-line bus where the circuit connects.

On a dual circuit one-line template, there are three bus-tap symbols. One at the normal point where the circuit ties into the bus. There is another version of the symbol on each of the two circuit "legs", each marking the point where that part of the dual circuit starts. These bus-tap symbols allow various reports to report accurately on a one-line circuit, whether a single circuit or a dual circuit representation.

The following bus-tap symbols are supplied:

- HDV1\_BT\_1.dwg - with "dot" for horizontal one-line circuit
- VDV1\_BT\_1.dwg - with "dot" for vertical one-line circuit
- HDV1\_BTT\_1.dwg - "tee" connection for dual horizontal circuit
- VDV1\_BTT\_1.dwg - "tee" connection for dual vertical circuit
- HDV1\_BTL\_1.dwg - "corner" connection for dual horizontal circuit
- VDV1\_BTL\_1.dwg - "corner" connection for dual vertical circuit

---

**NOTE** A WDTYPE attribute with a "1-1" value, identifies a bus-tap symbol.

---

# Overview of Hydraulic and P&ID symbols

The hydraulic symbol library consists of all the hydraulic symbols and is found under

- **Windows XP:** C:\Documents and Settings\All Users\Documents\Autodesk\Acade {version}\Libs\hyd\_iso125
- **Windows Vista, Windows 7:** C:\Users\Public\Documents\Autodesk\Acade {version}\Libs\hyd\_iso125

## Hydraulic family names

Family Name	Description
FI	Filter
CYL	Cylinder
VAL	Valves (directional, throttle valve, pressure valve)
FC	Flow control valve
CK	Check valve
MAN	Manifolds
PS	Pressure switch
MOT	Motor
PMP	Pump
ACC, CMP	Accumulator, compensator
MTR	Meter
FS	Float switch
HE, HTR	Heat exchanger, heaters

A Piping and Instrumentation Diagram (P&ID) is a schematic illustration of functional relationship of piping, instrumentation, and system equipment. P&ID shows all of piping including the physical sequence of branches, reducers,

valves, equipment, instrumentation, and control interlocks. The P&ID are used to operate the process system.

The P&ID symbol library consists of all the P&ID symbols and is found under

- **Windows XP:** C:\Documents and Settings\All Users\Documents\Autodesk\Acade {version}\Libs\pid
- **Windows Vista, Windows 7:** C:\Users\Public\Documents\Autodesk\Acade {version}\Libs\pid

### **P&ID family names**

<b>Family Name</b>	<b>Description</b>
CT	Equipment: Cooling tower
TK	Equipment: Cyclone
E	Equipment: Engine, exchanger
C	Equipment: Turbine, compressors
F	Equipment: Fans
M	Equipment: Mixer, agitators
TK, V	Tanks and vessels
N	Nozzles
P	Pumps
FIT	Fittings
GVA	Valves
ACT	Actuators
LOG	Logic Functions
INS	Instrumentation
FLW, FE	Flow

# Attribute Requirements

## Schematic attributes

### Overview of schematic attributes

The following items are attribute requirements for various categories of schematic symbols. Some attributes are used in multiple categories.

#### Schematic parent and child components

Attribute	Description
TAG1	<p>(Parent only) Attribute for required component tag name (64 characters maximum). The default value you assign to this attribute definition becomes the family code character string AutoCAD Electrical uses to build the tag name of the component when the block is inserted into your schematic. This default value character string is used as the Family Code (%F) portion of the tag format code of the drawing you set up in the Drawing Properties dialog box.</p> <p><b>Example:</b> The TAG1 attribute definition on the symbol carries a default value of "MCR" and the tag format of the drawing is "%F%N" where %N is the placeholder for the line reference number or next sequential number. As each instance of this symbol is inserted, it is automatically assigned a tag name with an "MCR" prefix tacked on to the reference or next sequential number.</p> <hr/> <p><b>NOTE</b> When a component is marked with a fixed tag, this attribute name is automatically changed with a "F" suffix (that is, TAG1 ► TAG1F).</p> <hr/>
TAG2	<p>(Child only) This is a copy of the parent component's tag name of the component (64 characters maximum). If no parent tag is found then AutoCAD Electrical displays the attribute default value of the definition (for example, "MCR" or "PB" or "X").</p>
TAG1_PART1 TAG1_PART2	<p>(Parent only) Alternate to using a single TAG1 attribute (64 characters maximum). This allows the component tag name to be split into two pieces (example: two lines - "MDOT" on first line and "123" on the second line for a full tag name of "MOT123"). AutoCAD Electrical pastes the values on these two attributes together when it processes</p>

Attribute	Description
	<p>the component. To include a delimiter character in the tag name but not show it on the drawing (for example, "MOT-123" but just show "MOT" and "123"), then a third attribute definition marked invisible, "TAG1_PARTX" can be added to carry the dash delimiter.</p> <hr/> <p><b>NOTE</b> The default for the %F tagging parameter, as described in TAG1 previously, is carried on the TAG1_PART1 piece of the attribute pair. If a component with a split tag is marked as Fixed, the attribute names are automatically changed to "TAG1F_PART1" and "TAG1F_PART2."</p> <hr/>
TAG2_PART1 TAG2_PART2	(Child only) Same as previous but for child components (64 characters maximum).
COPYTAG	Optional attribute that can carry a copy of whatever AutoCAD Electrical assigns to the tag name attribute - TAG1 or the split tag attribute combination (64 characters maximum).
MFG	<p>Attribute used to hold manufacturer name or code (24 characters maximum). This attribute usually marked as invisible.</p> <p>MFG01 - MFG10: Optional invisible attributes for manufacturer name or code for up to 10 additional "Multiple Catalog" part number assignments (24 characters maximum each). If these attributes are not present and AutoCAD Electrical stores the additional part number information, it is saved on the inserted symbol as Xdata.</p> <hr/> <p><b>NOTE</b> MFG, CAT, and ASSYCODE generally appear on parent components only; not child contact symbols.</p> <hr/>
CAT	<p>Attribute used to hold catalog part number assignment (60 characters maximum). This attribute is usually marked as invisible.</p> <p>CAT01 - CAT10: Optional invisible attributes for catalog number code for up to 10 additional "Multiple Catalog" part number assignments (60 characters maximum each). If these attributes are not present and AutoCAD Electrical stores the additional part number information, it is saved on the inserted symbol as Xdata.</p>
ASSYCODE	Invisible attribute for optional subassembly code that causes AutoCAD Electrical to look for subassembly items to extract into BOM reports (60 characters maximum). Define these subassembly items in the active catalog lookup file in the ASSYCODE and ASSYLIST fields. The

Attribute	Description
	<p>value for this attribute is set automatically when you make a selection from the catalog lookup that carries subassembly information.</p> <p>ASSYCODE01 - ASSYCODE10: Optional invisible attributes for sub-assembly code for up to 10 additional Multiple Catalog part number assignments (24 characters maximum each). If these attributes are not present and AutoCAD Electrical stores the additional part number information, it is saved on the inserted symbol as Xdata.</p>
ITEM	Attribute for the item or detail number for a component.
FAMILY	<p>Invisible attribute that carries the components family type (for example, "CR", "TD", "M", "PB"; eight characters maximum). Generally, the default value of the FAMILY attribute definition is the same as the default value for the TAG1 or TAG2 attribute of the component. It is used as a check at the time child components are linked to a parent. On a family mismatch, an alert dialog box displays.</p> <p>A generic child device can be linked to any type of parent symbol if the Family attribute value of the child is left blank. AutoCAD Electrical fills it in on the fly with the FAMILY code of the parent when the link is made.</p>
DESC1 DESC2 DESC3	<p>DESC1: Description, first or only line of description text (60 characters maximum).</p> <p>DESC2: second line of description text.</p> <p>DESC3: third line of description text.</p>
INST	Optional component installation code (for example, "MACH1"; 24 characters maximum).
LOC	Optional component location code (for example, "FIELD", "JBOX2" ; 16 characters maximum).
XREFNO XREFNC	(Parent only) Attributes to hold normally open and normally closed cross-reference annotation. These attributes automatically switch to invisible if graphical cross-referencing is applied to the component symbol.
XREF	Use this attribute in two ways. Use it for a combined list of normally open and normally closed contacts. AutoCAD Electrical underlines the closed contacts. If XREFNO and XREFNC are present, then this XREF attribute is used to carry undefined, non-NO/NC references.



Attribute	Description
	<p><b>NOTE</b> If XREF is not present then non-NO/NC contacts are included with the XREFNO annotation.</p>
CONTACT	<p>Invisible attribute that is present when the symbol is a contact. The value of this attribute is the de-energized state of the contact (for example, "NO" or "NC" or any text string with an embedded "NO" or "NC" such as "NO-TC". Use "NULL" as the value of the contact attribute to exclude the contact from being included in any AutoCAD Electrical cross-reference text annotation.)</p>
COMMON	<p>Optional attribute that defines which TERMxx attribute receives the first PINLIST value. The attribute value is a two character string, for example "02", that matches with one of the TERMxx attributes found on the symbol. If this attribute does not exist on the symbol, the first PINLIST value is assigned to TERM01 and the second to TERM02.</p>
POSn	<p>Attribute to mark switch position text where "n" is the position number digit (POS1 through POS12; 24 characters maximum). You can leave the default value blank and then fill it in at component insertion time.</p>
STATE	<p>Optional contact state character string to denote relationship between switch positions and open/closed contact state. It is for display only. You can leave the default value blank and then fill it in at component insertion time.</p>
RATINGn	<p>Optional rating / value attribute text where "n" is a digit starting with "1" (60 characters maximum). AutoCAD Electrical supports up to 12 RATINGn attributes (for example, RATING1 through RATING12) on the component symbol. These assignments can be pulled into various AutoCAD Electrical reports.</p>
X?LINK	<p>Optional invisible attribute that allows AutoCAD Electrical to tie in dashed link lines automatically between related components (instead of cross-reference annotation). The "?" is a digit that indicates the preferred link line connection direction and follows the wire connection convention (see X?TERMn).</p>
PINLIST	<p>(Parent only) Optional invisible attribute carried on a parent symbol for storing the allowed contact pin list for the child contacts of the parent (no limit on characters). If this attribute is not present then</p>

Attribute	Description
PEER_PINLIST	<p>any related pin list data is automatically stored on the symbol as Xdata.</p> <p>(Parent only) Like previous attribute, but is used to hold a second pin list temporarily that is later retrieved during insertion of a peer parent device. For example, a reversing motor starter contactor might be a single component with a single part number, but has a parent coil and a peer reversing coil. Each is to receive its own unique pin list. The catalog lookup assignment pulls both sets of pin lists to the parent. Then, inserting the peer reversing coil and referencing the parent, the pin list of the peer is retrieved from this temporary storage attribute (or Xdata) on the parent and pulled over to the peer.</p>
WDTAGALT	<p>(Parent only) Optional attribute carried on a parent symbol used for setting up a peer-to-peer relationship. It stores the cross-reference tag name of a related symbol shown on a different drawing type (for example, instrument drawing or pneumatic drawing vs. electrical schematic. For example, an instrument drawing might be included in an AutoCAD Electrical project drawing set with a valve marked "FY201". On the electrical schematics, the solenoid for this instrument valve is tagged "SV456". The WDTAGALT attribute carried on the schematic valve symbol can be annotated with the "FY201" instrument tag name and a WDTAGALT attribute on the symbol of the instrument diagram carries the "SV456" tag name pointing back at the schematic representation. With it in place, AutoCAD Electrical can cross-reference between them, do auto-update, and enable surfing from one drawing type to the other.</p> <hr/> <p><b>NOTE</b> For cross-referencing to include these peer references, make sure that the Peer-to-peer toggle is turned on (under Project Properties ► Cross-reference tab).</p> <hr/>
WDTYPE	<p>Optional attribute used to define the component category.</p> <ul style="list-style-type: none"> <li>1- = one-line</li> <li>1-1 = one-line bus-tap</li> <li>HY = hydraulic</li> <li>PI = P&amp;ID</li> <li>PN = pneumatic</li> </ul>

Attribute	Description
	<p><b>NOTE</b> The WDTYPE value can be a user-defined value. AutoCAD Electrical reserves all two character values. User-defined values must be three or four characters long.</p>

WD_WEBLINK	<p>Attribute carried on a parent symbol for embedding Internet URL's, ".pdf", ".xls", or ".doc" links that can be surfed on. The attribute value should be the URL, .pdf, .xls, or .doc document file name that should be displayed when selected from the Surf dialog box of the component. Multiple weblink attributes can be assigned to a symbol. Use attribute names with the WD_WEBLINK prefix, for example, WD_WEBLINK1 and WD_WEBLINK2.</p>
------------	---

### One-line

A one-line symbol can be a parent, child, or terminal. These one-line symbols use the same attributes as the schematic parent, child, and terminal symbols but with the following exceptions.

Attribute	Description
WDTYPE	<p>The attribute must be present and carry a value of "1-" to indicate it is a one-line symbol, or "1-1" for the one-line bus-tap symbols. A bus-tap symbol is used to mark the beginning of a one-line circuit. Schematic symbols do not carry this attribute or have the attribute but with a blank value.</p>
RATING1	<p>Omitted from one-line cable markers symbols since a one-line cable marker can represent multiple conductors, multiple wires, or core color assignments.</p>
TERM01	<p>Omitted from one-line terminal symbols since a one-line terminal can represent multiple independent terminals.</p> <p>If a TERM01 attribute is added to a one-line symbol and carries a non-blank value, it can be edited in the Insert/Edit Terminal Symbol dialog box. However, terminal number text on one-line terminal symbols is not linked back to terminal number assignments on schematic or panel terminal representations.</p> <p><b>NOTE</b> Terminal Strip Editor does not process one-line terminals.</p>

## Wire connection/terminal pin number pairs

Attribute	Description
X?TERMn	<p>Invisible wire connection attributes where an external wire connects to the origin point of the attribute. The "n" character is an incremented digit starting at "01" used to keep multiple wire connection point attribute names unique. It also provides a link to an associated terminal number (TERMn) and a terminal description (TERMDESCn) attribute. The "?" character position is used to identify the preferred wire connection direction:</p> <ul style="list-style-type: none"><li>■ 1: wire connects to the attribute from the right</li><li>■ 2: wire connects to the attribute from above</li><li>■ 4: wire connects to the attribute from the left</li><li>■ 8: wire connects to the attribute from below</li><li>■ 0: special for motor connections that radiate from a circle.</li></ul> <hr/> <p><b>NOTE</b> When a component is inserted with, nearby wires try to connect to this type of attribute only if it has a default prompt value of "X0STRETCH"</p> <hr/> <p>If more than 99 terminals are present on a single symbol, the "n" value can continue with double alpha letters/numbers such as "A0," "A1," "AZ," "B0" and so on.</p> <hr/> <p><b>NOTE</b> X?TERMn attributes can be stand-alone, meaning there is not an associated TERMn attribute.</p> <hr/>
X?TERMDESCn	<p>Optional wire connection description attributes that match up with X?TERMn wire connection attributes (128 characters maximum). The value assigned to each termination description attribute can be extracted into various wire connection reports or merged onto panel wiring diagram representations of schematic symbols.</p> <p>Use these attributes to define a terminal as an internal or external connection.</p>
TERMn	<p>Optional terminal pin number attribute where "n" is a two-digit number (starting at 01) that is used to match up with the corresponding X?TERMn wire connection attribute (ten characters maximum). A single TERMn attribute can have two, three, or four wire connection attributes associated with it. For example, a round, stand-alone terminal symbol having a single terminal in number attribute TERM01</p>

Attribute	Description
WD_JUMPERS	<p>can carry four wire connection attributes to allow connection from any direction. All four wire number attribute names would end with 01 to link them all to the common terminal pin number attribute.</p> <p>Optional internal wire jumpers attribute that can be encoded to link sets of terminals together so AutoCAD Electrical considers them internally jumpered when calculating wire number assignments and processing wire connection and from/to reports. For example, a WD_JUMPERS attribute value of ((01 02)) flags AutoCAD Electrical to treat wire connection X?TERM01 as electrically jumpered to XD?TERM02. WD_JUMPERS attribute value of ((01 04)(02 05 06)) means that wire connection X?TERM01 and X?TERM04 are treated as internally jumpered together and X?TERM02, X?TERM05, and X?TERM06 are viewed as jumpered together.</p> <hr/> <p><b>NOTE</b> You can keep jumpers from displaying in Wire From/To reports by placing the jumpers on a layer that contains the substring "JUMPER."</p> <hr/>

### Schematic connector parametric build symbols

The parametric connector is made up of a series of master symbols; one parent and multiple children (default library symbol names HCN1\_1\*.dwg, VCN1\_1\*.dwg, HCN2\_1\*.dwg, VCN2\_1\*.dwg). See the following list of attributes for these symbol types.

#### Parent and Child Pin symbol attributes

(parent symbol has "1" and child has "2" as fourth character of the symbol name)

Attribute	Description
TAG1	(Parent only) Same as the FAMILY attribute definition.
TAG2	(Child only) Same as the FAMILY attribute definition.
INST LOC	Same as the FAMILY attribute definition.

Attribute	Description
MFG CAT ASSYCODE	(Parent only) Same as the FAMILY attribute definition.
FAMILY	Same as the FAMILY attribute definition.
GENDER	Invisible attribute with blank value.
ACE_FLAG	Invisible attribute with a value of "2" for all parametric connector symbols and a value of "1" for splice symbols (1 character maximum).
DESC1 DESC2 DESC3	Same as the FAMILY attribute definition.
X?LINK	Same as the FAMILY attribute definition.
WDBLKNAM	(Parent only) Invisible attribute with a value of "HC0" (0 = zero; 32 characters maximum). Flags access of the "C0" connector table in the catalog lookup database file.

#### Parametric Connector - Wire Connection attributes

Attribute	Description
TERM01P	Attribute for terminal pin number (for plug pin number).
TERM01J	Attribute for terminal pin number (for receptacle pin number).
X?TERM01P X?TERM01J	Invisible wire connection attributes for plug and receptacle side respectively. The "?" is the wire connection direction digit (1, 2, 4, or 8).
X?TERMDESC01P X?TERMDESC01J	Attribute for terminal pin description for plug side and receptacle side respectively. The "?" digit is same as the FAMILY attribute definition.

Attribute	Description
X?WIRE01P X?WIRE01J	Attribute for wire connection annotation for plug side and receptacle side respectively. The "?" digit is same as the FAMILY attribute definition.
X?_TINY_DOT_DONT_REMOVE_01P X?_TINY_DOT_DONT_REMOVE_01J	Visible attribute, small, single character value (a ".") that must remain visible and must be placed at the exact insertion location of the XnTERM01P and XnTERM01J attributes. Maintains wire connection integrity if a connector pin is moved beyond the end of the connector shell. The "?" digit is same as the FAMILY attribute definition.

### Schematic terminal symbols

Use the following attributes for terminal symbols or multi-connection sequence terminal symbols (default library symbol block names HT00\*.dwg, VT00\*.dwg, HT10\*.dwg, VT10\*.dwg, HT0W\*.dwg, VT0W\*.dwg).

Attribute	Description
TAGSTRIP	Attribute to carry terminal strip tag name (24 characters maximum).
X?TERM01	Attribute for wire connection (up to four attributes positioned at each end of the horizontal and vertical axes of the symbol with the "?" part giving the wire connection direction digit as described previously).
X?TERMDESC01	Optional attribute for wire connection description.
STRIPSEQ	Attribute used internally by the Terminal Strip Editor command to sort a terminal strip.
LINKTERM	Attribute used internally to associate schematic terminals within one multi-level terminal or to associate a schematic terminal to its panel representation.
WIRENO or TERM01	Attribute to carry the terminal number assignment (24 characters maximum). If the terminal is to display the wire number value of the wire network that it is inserted into, then WIRENO attribute must be present. Otherwise, if the attribute is to carry a terminal pin assignment independent of the wire number, attribute TERM01 must be used.

Attribute	Description
INST	Same as previous attribute.
LOC	Same as previous attribute.
MFG CAT ASSYCODE	Same as previous attribute.
WDBLKNAM	Optional invisible attribute with value of "TRMS" to force access of the TRMS table in catalog lookup (32 characters maximum).

### Special Multiple Connection Sequence Terminal symbol

Use the following attributes for this special type of terminal symbol. This single symbol instance can be used to define a series of up to six terminal strip inter-connections (example, a wire that passes through a series of shipping split terminal strips). Default library symbol block names H--1\_multi\*.dwg, V--1\_multi\*.dwg.

Attribute	Description
WD_#_TAGSTRIP	Attribute to carry terminal strip number (16 characters maximum). Use WD_1_TAGSTRIP for the first terminal strip number and select from WD_2_TAGSTRIP through WD_6_TAGSTRIP for the next terminal number in the sequence.
WD_#_TERMNO	Attribute to carry optional terminal number. Use WD_1_TERMNO for the first terminal strip number and select from WD_2_TERMNO through WD_6_TERMNO for the next terminal number in the sequence.
WD_#_INFO	Attribute to carry additional information such as installation, location, catalog, and item number assignments; and any connected cable information. Use WD_1_INFO for the first terminal strip number and select from WD_2_INFO through WD_6_INFO for the next terminal number in the sequence.
X?TERM01 X?TERM02	Attribute for wire connections on each end of the symbol, the "?" character is the wire connection direction, same as previous attribute.



### Source/Destination wire signal symbols

These symbols allow a wire to jump from one place to another, either within a drawing or across multiple drawing. Default library symbol names are HAxSn.dwg, HAxDn.dwg where "x" = style digit and "n" = orientation 1, 2, 3 or 4.

Attribute	Description
SIGCODE	Attribute carries unique signal code that is user defined as the symbol is inserted (32 characters maximum). This value is used to match up each source signal symbol with it one or more destination signal symbols.
WIRENO	Attribute carries a copy of the wire number that gets assigned to the wire that the signal symbol is attached to (24 characters maximum). This attribute can be hidden.
XREF	Attribute carries the reference location for the matching source or destination symbols. Updates automatically with the Update Signal References tool or Auto Wire Numbers tool.
DESC1	Optional description attribute (60 characters maximum).
SHEET	Optional attribute for the SHEET (%S) value assigned in the Drawing Settings (12 characters maximum). Updates automatically with the Update Signal References tool or Auto Wire Numbers tool.
DWGNAM	Optional attribute for the DWGNAM (%D) value assigned in the Drawing Settings (40 characters maximum). Updates same as previous attribute.
X?TERM01	Attribute for wire connection where the "?" character is the wire connection direction, same as previous attribute.

### Stand-alone Source/Destination cross-reference symbols

These symbols are like the previous ones, except there is no wire connection attribute and no WIRENO attribute. Default library symbol names are HAxS1\_REF.dwg, HAxD1\_REF.dwg where "x" = style digit.

### In-line wire labels or wire numbers

These symbols insert into a wire, break the wire, and reconnect at each end. They carry a text label or wire number in the gap between the connected wire

ends. They symbols can dynamically adjust their gap to accommodate the width of the in-line text. Default library symbol block names are HTO\_\*.dwg, VTO\_\*.dwg.

Attribute	Description
COLOR or WIRENO	Visible attribute for the text label (COLOR) or in-line wire text (WIRENO) (24 characters maximum). This attribute is center or middle justified and placed midway between the pair of wire connection attributes listed below.
X?TERM01	<p>Pair of invisible wire connection attributes where the wires connect. Connection is made to the origin point of each attribute. The "?" character position in each attribute name identifies the wire connection direction:</p> <ul style="list-style-type: none"> <li>■ 1: wire connects to the attribute from the right</li> <li>■ 2: wire connects to the attribute from above</li> <li>■ 4: wire connects to the attribute from the left</li> <li>■ 8: wire connects to the attribute from below</li> </ul>
X?_TINY_DOT_DONT_RE-MOVE	Visible attribute, small, single character value (a ".") that must remain visible and must be placed at the exact insertion location of each of the XnTERM01 attributes. This attribute allows the gap to auto-adjust to text width and to maintain connectivity through the symbol if the in-line label or wire number text is blanked or grows small compared to the total gap width in the wire.

### PLC single I/O point symbols

These attributes must be present on single, stand-alone I/O symbols with one or two wire connections. Default library symbol block names are PLCIOI\*.dwg and PLCIOO\*.dwg.

Attribute	Description
TAG1 TAG2	Attribute for PLC I/O module tag name (parent / child) with the default attribute definition value for the parent symbol becoming the "%F" part of the tag name format (64 characters maximum).
TAGA01	Attribute for the I/O address (32 characters maximum).
INST LOC	Same as above.

<b>Attribute</b>	<b>Description</b>
XREF	Same as above.
TERM01L TERM01R	Attribute for terminal pin number on each side (ten characters maximum). If just a single wire connection then the attribute name is TERM01.
X?TERM01L X?TERM01R	Attributes for wire connections on each side. If just a single wire connection then the attribute name is X?TERM01 where the "?" character is the wire connection direction.
TERMDESC01L TERMDESC01R	Optional terminal pin description attribute on each side of the symbol (128 characters maximum). If just a single wire connection then the attribute name is TERMDESC01.
MFG CAT ASSYCODE	(Parent only) Same as above.
DESCA01 - DESCE01	Attributes to hold up to five lines of description text (60 characters maximum).
LINE1 LINE2	Optional attributes to hold two lines of general text (example: "Rack" and "Slot" address numbers; 24 characters maximum).
DESC	(Parent only) Optional attribute for general description purposes (60 characters maximum).
FAMILY	Same as above - default value "PLC" (eight characters maximum).

### **Splice symbols**

<b>Attribute</b>	<b>Description</b>
XnWIRE01	Attribute for wire annotation.
XnWIRE02	Attribute for wire annotation.
TERMDESCxx	Attribute for wire connection description (128 characters maximum).
ACE_FLAG	Invisible attribute (value set to "1" to identify a splice symbol) used for export to Autodesk Inventor Professional (1 character maximum).

## Parametric Twisted Pair symbols

Attribute	Description
X?TERM01	<p>Pair of invisible wire connection attributes where the wires connect. Connection is made to the origin point of each attribute. The "?" character position in each attribute name identifies the wire connection direction:</p> <ul style="list-style-type: none"><li>■ 1: wire connects to the attribute from the right</li><li>■ 2: wire connects to the attribute from above</li><li>■ 4: wire connects to the attribute from the left</li><li>■ 8: wire connects to the attribute from below</li></ul>
X?_TINY_DOT_DONT_REMOVE	<p>Visible attribute, small, single character value (a ".") that must remain visible and must be placed at the exact insertion location of each of the XnTERM01 attributes. This attribute is needed to allow the gap to auto-adjust to text width and to maintain connectivity through the symbol if the in-line label or wire number text is blanked or grows small compared to the total gap width in the wire.</p>
ACE_OFFSET	<p>Invisible attribute that carries the vertex offset distance measured from the midpoint of the symbol's two wire connection points. A positive value extends the twist through the gap. A negative value (default) decreases the height of the twist. A value of 0.0 makes the twist come up to the wire-gap midpoint.</p> <p>To change the height of the twist, open the symbol drawing file and edit this attribute definition. The next time you insert a twisted pair symbol into a new drawing, the twisted part takes on the new value.</p>
ACE_FLAG	<p>Invisible attribute set to a value of 3 to identify a twisted pair symbol (1 character maximum).</p>

## Overview of parent and stand-alone component attributes (TAG1)

AutoCAD Electrical puts the tag name of the component on this attribute, names like "PB101" or "CR-55" (24 characters maximum). The default value

you assign to this attribute definition at the library symbol level (that is, ".dwg" file of the symbol opened and displayed in AutoCAD) becomes the family code character string AutoCAD Electrical uses to build the tag name of the component when the block is inserted into your wiring diagram. This default value character string is used as the Family Code (%F) portion of the tag format code of the drawing you set up in the Drawing Properties ► Components dialog box (example %F%N).

For example, use "PB" for a default value of the attribute definition TAG1 if the family name you want AutoCAD Electrical to use is "PB" (examples: "PB100", "100-PB", "PB4-100"). You can override this family name at component insertion time, a later edit, or automatically by use of the "wd\_fam.dat" mapping file.

---

**NOTE** If the TAG1 attribute carries no default value then AutoCAD Electrical uses the FAMILY attribute value of that symbol.

---

## Overview of child component attributes (TAG2)

AutoCAD Electrical puts a copy of the parent tag name of the component on the child component attribute (TAG2). During the AutoCAD Electrical tagging operation, AutoCAD Electrical takes the parent tag name of the coil (carried on its TAG1 attribute) and copies it to the TAG2 attribute of this contact. If no parent tag is found then AutoCAD Electrical displays the attribute default value of the definition.

## Panel attributes

### Overview of panel attributes

AutoCAD Electrical does not have attribute or naming requirements for the mechanical footprint block symbols. As AutoCAD Electrical inserts a footprint symbol into the drawing, it copies various data to the footprint block such as component/device tag name, description, manufacturer code, and catalog number. It first looks for target attributes to copy the data to. If not found, AutoCAD Electrical simply inserts the schematic values as standard AutoCAD, nonvisible extended entity data (Xdata).

Some manufacturers provide free, to-scale mechanical libraries of their control components, all in AutoCAD format. Or you may have your own in-house footprints set up. In either case, since AutoCAD Electrical does not have naming

or attribute requirements, these libraries can be used as is. When AutoCAD Electrical inserts such a block footprint symbol, it immediately becomes AutoCAD Electrical smart.

### Footprint block attribute/Xdata names

The following table is a list of footprint block data names that are inserted or read by AutoCAD Electrical. If the footprint block has an attribute with any name listed here, AutoCAD Electrical uses that attribute to carry the specific piece of data. Otherwise, AutoCAD Electrical uses extended entity data with names based on the data names listed here but with a VIA\_WD\_ prefix (ex: "VIA\_WD\_DESC1").

FP	identifies block as a component footprint
FPT	identifies block as a terminal footprint
NP	identifies block as a nameplate
P_TAG1	panel component tag (used on component footprints and nameplates)
DESC1-3	description line 1 - 3 (60 char max)
P_ITEM	item/detail number
ITEM_FLAG	optional attribute with a value of 1 indicates the item number is fixed
MFG	manufacturer name (24 char max)
CAT	catalog number (60 char max)
ASSYCODE	optional assembly code
INST	installation code (24 char max)
LOC	location code (16 char max)
MOUNT	mount location code (24 char max)
GROUPWITH	group location code (24 char max)
WDBLKNAM	schematic symbol block name (used for catalog lookup)
RATING1-12	rating values (60 char max each)

P_TAGSTRIP	terminal strip ID (terminal footprints only)
TERM	terminal number (terminal footprints only)
WIRENO	wire number (terminal footprints only)

### Minimum attribute/Xdata requirements

The following tables are the minimum requirements for AutoCAD Electrical to recognize a block as a panel footprint, terminal, or nameplate.

**Component footprint** - block must carry a minimum of one of the following:

Xdata name	VIA_WD_FP
Attribute	FP (blank value)
Attribute	P_TAG1 (and no attribute NP present)

**Terminal footprint** - block must carry a minimum of one of the following:

Xdata name	VIA_WD_FPT
Attribute	FPT (blank value)

**Panel nameplate** - block must carry a minimum of one of the following:

Xdata name	VIA_WD_NP
Attribute	NP (blank value)

### Terminal block footprint symbols

Terminal block footprint symbols require special attributes in their definitions to help facilitate the Terminal Strip Editor graphical layout. AutoCAD Electrical generates a physical layout of the terminal strips. It annotates the terminal number, wire number, and destination device of what is connected to the terminal block from the attributes. To accomplish this annotation, attributes

are needed to accommodate the position of text relative to the terminal block symbol.

<b>Attribute</b>	<b>Description</b>
P_TAGSTRIP	Invisible attribute to carry terminal strip number (24 character maximum) for terminal footprint.
LOC	Invisible attribute for optional terminal location code (for example, "JBOX1"; 16 characters maximum).
INST	Invisible attribute for optional terminal installation code (for example, "MACH1"; 24 characters maximum).
TERM or WIRENO	Attribute to carry the terminal pin number assignment (ten characters maximum). It can be related to the attached wire number or independent of the wire number.
P_ITEM	item/detail number
ITEM_FLAG	optional attribute with a value of 1 indicates the item number is fixed
MFG	Invisible attribute for optional manufacturer name or code (24 characters maximum).
CAT	Invisible attribute for optional catalog number (60 character maximum).
ASSYCODE	Invisible attribute for optional subassembly code that causes AutoCAD Electrical to look for subassembly items to extract into BOM reports (60 characters maximum). These subassembly items must be defined in the active catalog lookup file in the ASSYCODE and ASSYLIST fields. The value for this attribute is set automatically when you make a selection from the catalog "Lookup" that carries subassembly information.
WDBLKNAM	Invisible attribute that specifies the WD block name for catalog lookup (32 characters maximum). Default for terminals is "TRMS."
FP	Invisible attribute or Xdata. Identifies the block insert as a panel item (that is, a physical footprint representation).
FPT	Invisible attribute or Xdata. Identifies the block insert as a panel terminal footprint representation.



Attribute	Description
WIRENOR WIRENOL	Optional attributes for schematic interconnection annotation (24 characters maximum).
TERMDESCR TERMDESCL	Optional attributes for schematic interconnection annotation (128 characters maximum).

## Attributes for other symbol categories

### Overview of attributes for other symbol categories

#### WDTYPE attribute

The WDTYPE attribute value specifies a component category for a non-schematic, non-panel component. It is limited to four characters and can be user-defined. For some schematic reports, you can select a component category for the report based on the WDTYPE value.

---

**NOTE** AutoCAD Electrical reserves all two-character values. User-defined values must be three or four characters long.

---

AutoCAD Electrical uses the following WDTYPE attribute values.

Attribute Value	Symbol category
1-	One-line
1-1	One-line bus-tap
HY	Hydraulic
PN	Pneumatic
PI	P&ID

### One-line symbols

A one-line symbol can be a parent, child, or terminal. These one-line symbols use the same attributes as the schematic parent, child, and terminal symbols but with the following exceptions.

Attribute	Description
WDTYPE	The attribute must be present and carry a value of "1-" to indicate it is a one-line symbol, or "1-1" for the one-line bus-tap symbols. A bus-tap symbol is used to mark the beginning of a one-line circuit. Schematic symbols do not carry this attribute or have the attribute but with a blank value.
RATING1	Omitted from one-line cable markers symbols since a one-line cable marker can represent multiple conductors, multiple wires, or core color assignments.
TERM01	Omitted from one-line terminal symbols since a one-line terminal can represent multiple independent terminals. If a TERM01 attribute is added to a one-line symbol and carries a non-blank value, it can be edited in the Insert/Edit Terminal Symbol dialog box. However, terminal number text on one-line terminal symbols is not linked back to terminal number assignments on schematic or panel terminal representations.

---

**NOTE** Terminal Strip Editor does not process one-line terminals.

---

### Hydraulic and P&ID symbols

Attribute	Description
TAG1	Attribute for required component tag name (64 characters maximum). The default value you assign becomes the family code character string AutoCAD Electrical uses to build the tag name of the component when the block is inserted into your wiring diagram. This default value character string is used as the Family Code (%F) portion of the tag format code of the drawing you set up in the Drawing Properties ► Components dialog box (example %F%N).
INST	Optional attribute for component installation code (for example, "MACH1"; 24 characters maximum).
LOC	Optional attribute for component location code (for example, "FIELD"; "JBOX2"; 16 characters maximum).

Attribute	Description
FAMILY	Invisible attribute that carries the components family type (for example, "FI", "INS"; eight characters maximum). Generally, the default value of the FAMILY attribute definition is the same as the default value for the TAG1 or TAG2 attribute of the component. A generic child device can be linked to any type of parent symbol when the Family attribute value of the child is left blank. AutoCAD Electrical fills it in on the fly with the FAMILY code of the parent when the link is made.
CAT	Invisible attribute for optional catalog number (60 characters maximum).
MFG	Invisible attribute for optional manufacturer name or code (24 characters maximum).
ASSYCODE	Invisible attribute for optional subassembly code that causes AutoCAD Electrical to extract subassembly items into BOM reports (60 characters maximum). AutoCAD Electrical, not the user, sets the value for this attribute.
RATING1	Optional attribute for rating/value text (60 characters maximum).
DESC1, DESC2, DESC3	DESC1: Description, first or only line of description text (60 characters maximum). DESC2: second line of description text. DESC3: third line of description text.
WDTYPE	Optional attribute used to define the component category. <b>1</b> - = one-line <b>1-1</b> = one-line bus-tap <b>HY</b> = hydraulic <b>PI</b> = P&ID <b>PN</b> = pneumatic
	<hr/> <b>NOTE</b> The WDTYPE value can be a user-defined value. AutoCAD Electrical reserves all two character values. User-defined values must be three or four characters long. <hr/>
WDTAGALT	Attribute carried on a parent symbol used for setting up a "peer-to-peer" relationship (64 characters maximum). It stores the cross-refer-

Attribute	Description
	<p>ence tag name of a related symbol shown on a different drawing type (for example, instrument drawing or pneumatic drawing vs. electrical schematic). For example, an instrument drawing might be included in an AutoCAD Electrical project drawing set with a valve marked "FY201". On the electrical schematics, the solenoid for this instrument valve is tagged "SV456". You can annotate the The WDTAGALT attribute carried on the schematic valve symbol with the "FY201" instrument tag name. A WDTAGALT attribute on the symbol of the instrument diagram carries the "SV456" tag name pointing back at the schematic representation. AutoCAD Electrical can cross-reference between them, do auto-update, and enable surfing from one drawing type to the other.</p>
XREF	<p>Attribute used for a combined list of normally open and normally closed contacts (if XFREFNO and XREFNC are present). Or, used for non-NO/NC contacts (if XREFNO and XREFNC are not present). AutoCAD Electrical underlines the closed contacts.</p>
TERM	<p>Optional terminal pin number attribute (ten characters maximum). Make sure to keep terminal pin number text paired with its wire connection attributes.</p>
X?TERMn	<p>Invisible wire connection attributes where an external wire connects to the origin point of the attribute. The 'n' character is an incremented digit starting at "01" used to keep multiple wire connection point attribute names unique. The "?" character position is used to identify the preferred wire connection direction:</p> <ul style="list-style-type: none"> <li>■ 1: wire connects to the attribute from the right</li> <li>■ 2: wire connects to the attribute from above</li> <li>■ 4: wire connects to the attribute from the left</li> <li>■ 8: wire connects to the attribute from below</li> <li>■ 0: special for motor connections</li> </ul> <p>If more than 99 terminals are present on a single symbol, the 'n' value can continue with double alpha letters/numbers such as "A0," "A1," "AZ," "B0" and so on.</p>

## Copy attributes

COPYTAG is the optional TAG copy attribute. When AutoCAD Electrical updates a TAG1, TAG2 or TAGSTRIP attribute, it also looks for and updates any COPYTAG attributes present on the symbol with a copy of the TAG text. A special replaceable parameter, "%T", can be encoded onto the COPYTAG attribute prompt value of the definition. It allows for adding a suffix and/or prefix to the TAG text. If you need more than one extra TAG copy on a symbol, name the attributes COPYTAG01, COPYTAG02, and so on. If there is no prompt value encoded on the attribute definition, AutoCAD Electrical simply applies a copy of the tag-ID to the COPYTAG\* attributes.

For example, you create a large "drive" schematic symbol with a TAG1 attribute for the tag-ID of the drive. You want some other parts of this single symbol to carry the TAG1 value plus a suffix like "-POT" and "-DBRES". On your library symbol, insert an attribute definition "COPYTAG01" with a prompt value of "%T-POT" near the potentiometer graphic of the symbol and "COPYTAG02" with a prompt value of "%T-DBRES" near the dynamic braking resistor graphic. When this symbol is inserted on a schematic drawing, and a TAG is assigned, AutoCAD Electrical automatically updates each COPYTAG\* attribute accordingly.

## Managing Library Symbols

### Substitute symbols in the library

You can temporarily substitute an altered symbol for a symbol that is found in the standard library. Put the .dwg file of the altered symbol in your USER subdirectory (right-click a project name inside the Project Manager and select Settings to find the full path). The AutoCAD Electrical component insertion command always looks at this directory for the requested symbol before going to the selected symbol library.

---

**NOTE** AutoCAD Electrical uses regular AutoCAD blocks. If you insert a block from one library and then try to insert the same block name from a different library, you get a copy of the original version of the block. Use the Swap/Update Block command in AutoCAD Electrical to make the change.

---

## Change appearance of existing library symbols

### Change appearance of existing library symbols

The AutoCAD Electrical symbol libraries are installed in

- **Windows XP:** \Documents and Settings\All Users\Documents\Autodesk\Acade {version}\libs\{library}\
- **Windows Vista, Windows 7:** \Users\Public\Documents\Autodesk\Acade {version}\libs\{library}\

The default {library} folder depends on installation choices, for example JIC or IEC. You can modify the ".dwg" version of each symbol to comply with your specific standards or client requirements.

- 1 Open each symbol up in its native AutoCAD .dwg format (using File ► Open).
- 2 Move the tag, description, location, and cross-reference annotation attribute definitions to different locations to satisfy your drafting standards (attribute definitions look like text entities).
- 3 Adjust attribute definition text size to meet your requirements but avoid deleting any of the existing attribute definitions.  
Attributes give the symbol full compatibility with AutoCAD Electrical features.
- 4 Insert additional non-AutoCAD Electrical attributes that your applications might need.
- 5 Edit these attributes by clicking Show/edit miscellaneous on the AutoCAD Electrical edit dialog boxes.

---

**NOTE** Before you spend a lot of time modifying each library symbol, you may want to look at the AutoCAD Electrical [Modify Symbol Library](#) on page 892 tool. This tool provides a way to make mass changes to the library of symbols. It has some options, including scaling each symbol, changing attribute height based on AutoCAD Electrical attribute type, and picking a different text font for the AutoCAD Electrical text style.

---

#### Tips and Hints

Leave all symbol attribute definitions and geometry on layer "0" and that entity color assignments are by layer. Let AutoCAD Electrical manage what

layers the various parts and pieces of your symbol get put on at insertion time. This layer naming scheme is set up in the Define Layers dialog box. If you want certain layer naming maintained on your inserted components, select Apply to entities on layer "0" only. With it checked, non-layer "0" entities maintain their existing layer names as the component inserts into the drawing.

## **Edit miscellaneous and non-AutoCAD Electrical attributes**

View or edit any attributes that are not predefined AutoCAD Electrical attributes.

Click Show/edit miscellaneous on any of the Insert/Edit dialog boxes.

The attributes that can be modified depend on which Insert/Edit dialog box you are working in.

## **Predefine symbol annotation**

### **Predefine symbol annotation**

You can have certain symbols insert with switch position text, terminal pin numbers, or BOM catalog numbers prefilled with default values.

- 1 Open the .dwg file of the symbol in AutoCAD. The default symbol library path is  
**Windows XP:** \Documents and Settings\All Users\Documents\Autodesk\Acade {version}\Libs\{library}\  
**Windows Vista, Windows 7:** \Users\Public\Documents\Autodesk\Acade {version}\Libs\{library}\
- 2 Use the DDEDIT or PROPERTIES command to change the default attribute values of the symbol.

For example, let's say that you always want your N.O. limit switch symbol to insert showing the two terminal pin numbers labeled as "1" and "2." In AutoCAD, call up and edit these symbol files: HLS11.DWG, VLS11.DWG, HLS21.DWG, and VLS21.DWG (modify both the jic1 and jic125 versions). In each case use DDEDIT to change the TERM01 and TERM02 attribute default values to be "1" and "2" respectively. At insertion time, these values show up as defaults.

---

**NOTE** You can override the default values at insertion time.

---

## Swap blocks

The block swapper tool can operate in several different modes:

- **Swap Block:** Exchanges one block for another, retaining the scale of the old block, rotation, wire connections, attribute values, and attribute positions (if Retain is selected). For example, use the tool to swap out a red standard pilot light with a green one, or drawing-wide, swap out all standard red pilot lights with red press-test pilot lights.
- **Update:** Updates all instances of a given block with an updated version of the same block. Again, all attribute values and wire connections are retained. For example, an old AutoCAD Electrical project set must be used on a new project but the client likes the limit switches drawn a bit differently. Simply make client-specific versions of the limit switch symbols. Then use the Update option; select any limit switch on the drawing, and then reference the path to the new version of the symbol. AutoCAD Electrical quickly replaces all instances of the symbol it finds on the drawings with the new version of the same symbol. The Library mode works the same way as the Update mode, but swaps out all the blocks on the drawings.

When you swap or update a block there may be times when you want the values of certain attributes mapped to different attribute names. For example, you may be doing a Library Update and the library symbols you are swapping out do not use standard AutoCAD Electrical attribute names. You want a quick way to update the library symbols, but you do not want to lose information held on the current attributes.

### Update or change blocks in place

- 1 Click Schematic tab ► Edit Components panel ► Swap/Update Block.



- 2 Determine whether you want to exchange one block for another (Option A) or update all instances of a given block with an updated version of the same block (Option B).



**Option A:** Select to swap a block one at a time, drawing-wide, or project-wide.

- Indicate whether to pick a new block from the icon menu, pick a new block just like another block, or pick a new block from the File dialog box.
- Determine whether you want to retain old attribute locations, old block scales, or retag if parent swap causes family changes.

**Option B:** Select to update a block by replacing it with a new version or substitute new versions of all blocks.

- Specify the file name of the block that to substitute for all instances of the selected block.
- Determine whether you want to retain old attribute locations, old block scales, or copy the attribute values of the old block to new swapped block.

- 3 Select whether to use the same attribute names or use an attribute mapping file.
- 4 Click OK.
- 5 If you selected to pick a new block from the icon menu, select the icon from the Insert Component dialog box.
- 6 Select the component to swap out.
- 7 If you chose to do a project-wide swap, select the drawings to process and click OK.

The chosen component is replaced with the symbol selected in the Insert Component dialog box.

## Swap block/update block/library swap

Swaps or updates a block insert instance, and maintains existing attribute text values.

 **Ribbon:** Schematic tab ► Edit Components panel ► Swap/Update Block.





 **Toolbar:** Insert Component

 **Menu:** Components ► Component Miscellaneous ► Swap/Update Block

 **Command entry:** AESWAPBLOCK

- **Swap Block:** Exchanges one block for another. Select Retain to keep the scale of the old block, rotation, wire connections, attribute values, and attribute positions.
- **Update:** Updates all instances of a given block with an updated version of the same block.



Wire connections are also maintained even if the new symbol is slightly wider or narrower than the original.

### Swap Block (swap to different block name)

<b>Swap a block - one at a time</b>	Exchanges one block for another one block at a time.
<b>Swap a block - drawing wide</b>	Exchanges one block for another throughout the drawing.
<b>Swap a block - project wide</b>	Exchanges one block for another throughout the project.
<b>Pick new block from icon menu</b>	Specifies to select a new block from the icon menu.
<b>Pick new block "just like"</b>	Specifies to select a new block like the original block.

<b>Browse to new block from file selection dialog box</b>	Specifies to select a new block from the file selection dialog box.
<b>Retain old attribute locations</b>	Specifies to retain the attribute locations from the original block.
<b>Retain old block scale</b>	Specifies to retain the scale value from the original block.
<b>Allow undefined Wire Type line reconnections</b>	Specifies to include non-wire lines for reconnection when the new block swaps in.
<b>Auto retag if parent swap causes family change</b>	Automatically retags the component if the Family code of a component changed due to the swap. Otherwise, the tag remains the same even if it does not match the new component's Family code of the new component.

### **Update block (revised or different version of same block name)**

<b>Update a block</b>	Updates all instances of a given block with an updated version of the same block.
<b>Library swap</b>	Updates all instances of a library symbol with an updated version of the same symbol

### **Attribute mapping**

<b>Use same attribute names</b>	Uses the same attribute names from the original block.
<b>Use attribute mapping file</b>	Allows the values of certain attributes to be mapped to different attribute names.
<b>Mapping file</b>	Determines how AutoCAD Electrical should map the attributes. The file should have two columns of attribute names. The first column should contain the current attribute name and the second column the new attribute name. The mapping file may be an Excel spreadsheet, a comma-delimited file (.CSV), or a simple text file

with a space separating the current attribute name from the new attribute name.

## Library swap -- all drawing

Updates all instances of a library symbol with an updated version of the same symbol on the active drawing or in a project.

 **Ribbon:** Schematic tab ► Edit Components panel ► Swap/Update Block.



 **Toolbar:** Insert Component



 **Menu:** Components ► Component Miscellaneous ► Swap/Update Block

 **Command entry:** AESWAPBLOCK

Select the Library Swap option and click OK.

### Path to new block library

Specifies the path for the symbol library that is referenced for the block substitution. To use a different library, enter its path or click Browse. Check Include subfolders if the symbols are in folders within the specified path. It is true for panel footprint symbols.

### Insertion scale

<b>Scale</b>	Specifies which scale factor to use. 1.0 = full scale; Configuration Scale = the scale setting in the Drawing Properties ► Drawing Format dialog box; 25.4 = inch to millimeter scale factor; and 1/25.4 = millimeter to inch scale factor.
<b>Retain old block scale</b>	Specifies to retain the scale value from the original block.
<b>Retain old attribute locations</b>	Specifies to retain the attribute locations from the original block.

### Copy attribute values of old block to new swapped block

Specifies whether to copy the attribute values to the new block, to discard all old values, or to copy the old values only if the new value is blank.

### Update block - path\filename of new block

Substitutes a new version of a component block for all inserted instances of that block found on a drawing or in a project.

 **Ribbon:** Schematic tab ► Edit Components panel ► Swap/Update Block.



 **Toolbar:** Insert Component

 **Menu:** Components ► Component Miscellaneous ► Swap/Update Block

 **Command entry:** AESWAPBLOCK

Select the Update a Block option and click OK.

### Path\filename of new block

Specifies the path\filename of the block to substitute for all instances of the selected block. Enter a file name or click Browse.

### Insertion scale

#### Scale

Specifies which scale factor to use. 1.0 = full scale; Configuration Scale = the scale setting in the Drawing Properties ► Drawing Format dialog box; 25.4 = inch to millimeter scale factor; and 1/25.4 = millimeter to inch scale factor.

#### Retain old block scale

Specifies to retain the scale value from the original block.

#### Retain old attribute locations

Specifies to retain the attribute locations from the original block.

### Copy attribute values of old block to new swapped block

Specifies whether to copy the attribute values to the new block, to discard all old values, or to copy the old values only if the new value is blank.

## Create a library symbol

### Create a library symbol

AutoCAD Electrical uses stock AutoCAD blocks and attributes in its library symbols. The symbols can be any size and width. You do not have to edit an external support file or database to register a symbol for use in an AutoCAD Electrical wiring diagram drawing.

---

**NOTE** You can also use the Symbol Builder tool, but the quickest way to create a symbol might be to start with an existing AutoCAD Electrical compatible symbol. Start with a copy of a similar type and then modify to suit. Avoid deleting the existing attribute definitions. Reposition and edit their default values as required.

---

- 1 Open a new drawing using the appropriate symbol name.
- 2 Insert an exploded copy of an existing AutoCAD Electrical symbol that somewhat resembles what you need in the new symbol. Consider the number of wire connection points, rating attributes, and whether your new symbol is a parent symbol (attribute TAG1) or a child symbol (attribute TAG2).
- 3 Clean up the graphics. Keep everything on layer 0.
- 4 Reuse attribute definitions from the exploded symbol. Reposition them as required. Make sure that you keep terminal pin number text paired with its wire connection attribute (the last two digits of each attribute name must match, "X4TERM01" wire connection point attribute matched with "TERM01" terminal pin number text attribute).
- 5 Use DDEDIT to change the TAG1 or TAG2 and the FAMILY attribute values to the family code. Insert any pre-defined terminal pin, description, or catalog number attribute values.
- 6 Delete unneeded attribute definitions and graphics.
- 7 Save your work to the jic1, jic125, or user subdirectory (right-click a project name inside the Project Manager and select Settings to find the full path). To test it, call up a new or existing AutoCAD Electrical drawing. Try to insert your new symbol into an existing piece of wire. You can manually enter the file name of the new symbol using Type it on the main icon menu page.

### Tips and Hints

#### Pigtails

Avoid putting wire pigtails on your new symbols. Pigtails can defeat the AutoCAD Electrical SCOOT command and automatic wire numbering when two symbols with pigtails bump up against each other. A wire connection pigtail is mandatory when you insert a short pigtail at a wire connection point that has no other visible symbol geometry nearby since AutoCAD Electrical must see something tangible on a symbol at a wire connection point.

#### **Symbol origin**

The AutoCAD Electrical library symbols generally have their origin points centered between the first (or only) pair of wire connection point attributes. Though it is not mandatory, it helps AutoCAD Electrical determine the correct orientation for alignment with an underlying wire at insertion time.

#### **Symbol width**

There are no restrictions. Every symbol can have a different width. At insertion time the width of the symbol is determined by reading the locations of its wire connection attributes (attributes with name X?TERMn).

#### **Wire connection points**

A symbol can have hundreds of connection points and a terminal pin number attribute tied to each (use suffix codes beginning with "01" and ending with "ZZ").

#### **Component description text**

You can insert three lines of description text up to 60 characters long. The attribute names are DESC1, DESC2, and DESC3 and generally appear on both parent/stand-alone and child contact symbols. You can insert additional DESCn attributes on your symbol and edit them with any attribute editing tool, but AutoCAD Electrical does not process them.

## **Symbol Builder**

### **Symbol Builder**

Defines new AutoCAD Electrical component, terminal, and panel layout library symbols.

You can convert symbols or create custom components on the fly. Symbols created or converted using Symbol Builder are fully compatible with AutoCAD Electrical. They break wires upon insertion, and appear in the bill of material and various component and wire connection reports.

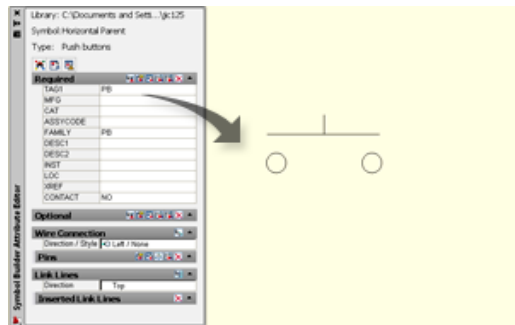

You can exit the Symbol Builder command and re-enter it at any time. You can also exit the command and use regular AutoCAD commands to edit or finish the symbol you are creating. The AutoCAD Wblock command writes it to disk. Each time you re-enter the Symbol Builder tool, select objects from within the Select Symbol/Objects dialog box. Selecting the objects allows the tool to track what standard attributes and wire connection points you already inserted.

New symbols you create are inserted with the AutoCAD Electrical Insert Component or Insert Panel Component commands. You can add your new symbol to the icon menu. You can also select it from the Type it or Browse options in the bottom left-hand corner of the icon menu.

### Symbol Types

<b>Schematic Parent</b>	Schematic symbol is used as a stand-alone symbol or a parent component with related secondary contacts. Must have a TAG1, TAG, or split TAG1 attribute.
<b>Schematic Child</b>	Schematic secondary symbol that is related to a parent component. Must have a TAG2 attribute.
<b>Schematic Terminal</b>	Schematic terminal with terminal number. Must have a TERMNO attribute.
<b>Schematic Terminal</b>	Schematic terminal that follows the wire number rather than having a terminal number of its own. Must have a WIRENO attribute.
<b>Panel Footprint</b>	Panel symbol that is not used as a terminal or nameplate. Must have a P_TAG1 and FP attribute or xdata.
<b>Panel Terminal</b>	Panel terminal symbol. Must have a P_TAGSTRIP and FPT attribute or xdata.



**Panel Nameplate** Panel nameplate symbol. Must have a P\_TAG1 and NP attribute or xdata.

---

**NOTE** Panel symbols do not require any attributes but uses xdata for any missing attributes. This xdata is added when the symbol is inserted using the appropriate AutoCAD Electrical panel insertion command. All xdata values have a VIA\_WD\_ prefix followed by the name of the attribute it takes the place of. For example, if a panel footprint does not have a P\_TAG1 attribute it gets a VIA\_WD\_P\_TAG1 xdata when inserted.

---

### **Block Editor Environment**

Once you make the initial selections, you enter to the Block Editor environment. Your initial selections can include symbol type, attribute template, existing objects, and insertion point. In addition to the Block Editor menus for adding and modifying the symbol graphics, a [Symbol Builder Attribute Editor](#) on page 346 is available for inserting and modifying the AutoCAD Electrical attributes.

### **Attribute Template**

AutoCAD Electrical expects certain attributes for each symbol type, schematic parent, schematic child, and so on. Symbol builder uses attribute templates to facilitate adding these attributes to your symbol. Attribute template drawings are AutoCAD drawings with AutoCAD Electrical attributes. There are different attribute templates for different types of symbols and for different family codes. The supplied attribute templates are in the symbol library folders and all attribute template drawing names begin with "AT\_".

When you select your symbol type, the associated attribute template is used to create a list of attributes. The attribute template can contain attributes defined as required and others as optional. The required attributes are expected on the specific symbol type you are building. Optional attributes are attributes that may not be necessary on this symbol type but are supported. For example rating or switch position attributes. You can insert the attributes individually as needed, or you can insert all the attributes from the template at one time.

Attribute templates follow the naming convention, AT\_{symbol}\_{type}. The {symbol} string is displayed in the Symbol list in the Select Symbol/Objects dialog box and the {type} string is displayed in the Type list. You can also map abbreviations for the {type} in the \_FAMILY\_DESCRIPTION table of the catalog database, default\_cat.mdb. For more information see [Create a Symbol Builder attribute template](#) on page 2105.

---

**NOTE** The attribute templates do not carry wire connection attributes. Add wire connection attributes to your symbol as needed. You can create your own [wire connection templates](#) on page 2107 which are used when inserting wire connections.

---

## Creating a symbol

Creating an AutoCAD Electrical symbol includes adding the necessary attributes based on the symbol type, and for a schematic symbol, selecting an appropriate file name. Symbol builder uses attributes templates to facilitate adding the attributes. If you select a schematic symbol type, symbol builder suggests a file name based on the AutoCAD Electrical naming conventions.

- 1 Click Schematic tab ► Other Tools panel ► Symbol Builder drop-down



- Symbol Builder.

- 2 Select options on the [Select Symbol / Objects](#) on page 342 dialog box making sure to select the attribute template library path, symbol, and type.
- 3 Click OK to enter the block editor environment.
- 4 [Insert attributes](#) on page 345 using the [Symbol Builder Attribute Editor](#) on page 346.
- 5 (schematic symbol) Insert [wire connection](#) on page 350 attributes.
- 6 (schematic symbol) Insert [link line](#) on page 353 attributes.
- 7 (optional) [Audit](#) on page 359 to see any potential issues with the symbol.
- 8 [Save](#) on page 356 the symbol.

## Select Symbol / Objects

Use this dialog box to define the type of symbol you are creating or editing, select existing objects, and define the insertion point. Select an existing block to edit or use it as the starting point for a new symbol.

-  **Ribbon:** Schematic tab ► Other Tools panel ► Symbol Builder



- drop-down ► Symbol Builder.



 **Toolbar:** Miscellaneous

 **Menu:** Components ► Symbol Library ► Symbol Builder

 **Command entry:** AESYMBUILDER

### Name

Lists all block definitions in the current drawing. Select an existing block to edit or use as a starting point for a new symbol. Select <unnamed> to create a symbol from scratch. Browse to select a drawing file not listed in the current drawing.

### Select From Drawing

Select any existing objects that are to be part of the symbol you want to create or edit. Existing objects can include an existing block, attributes, attribute definitions, and any symbol graphics. Select Specify on Screen to select objects after selecting OK, before entering the Block Editor.

### Insertion Point

Enter the insertion point coordinates for the symbol or select Pick Point to select on the drawing. Select Specify on Screen to specify the insertion point after selecting OK, before entering the Block Editor. These coordinates become the 0,0,0 insertion base point for the symbol.

### Attribute Template

#### Library path

Select a path to the symbol builder attribute templates. Browse to the folder or select from a list of the library paths for the current project.

---

**NOTE** To create a one-line symbol, select the one-line folder which by default is "1-" under the schematic library folder.

---

#### Symbol

Specify a symbol category such as Horizontal Parent. The category specifies the horizontal or vertical orientation of the symbol. It also defines whether it is schematic or panel, and within those categories parent, child, terminal, and so on.

---

**NOTE** The list is built dynamically based on the attribute templates in the selected folder. Attribute template block names begin with "AT\_".

---

Type

Select the type used to find the appropriate attribute template.

### Preview

Displays a preview of the selected named block or the objects selected on the drawing. Selected blocks are shown exploded.

### Symbol Configuration

Use this dialog box to select a different attribute template or redefine the insertion point.

 **Ribbon:** Schematic tab ► Other Tools panel ► Symbol Builder

drop-down ► Symbol Builder.



 **Toolbar:** Miscellaneous

 **Menu:** Components ► Symbol Library ► Symbol Builder

 **Command entry:** AESYMBUILDER

- 1 Select options on the [Select Symbol / Objects](#) on page 342 dialog box.
- 2 Click OK to enter the block editor environment.

- 3  Select the Symbol Configuration tool.

Library path

Select a path to the symbol builder attribute templates. Browse to the folder or select from a list of the library paths for the current project.

Symbol

Specify a symbol category such as Horizontal Parent. The category specifies the horizontal or vertical orientation of the symbol. It also defines whether it is schematic or panel, and within those categories parent, child, terminal, and so on.

---

**NOTE** The list is built dynamically based on the attribute templates in the selected folder. Attribute template block names begin with "AT\_".

---

<b>Type</b>	Select the type. This value is used to find the appropriate attribute template.
<b>Insertion Point</b>	Enter the insertion point coordinates for the symbol or select Pick point to select on the drawing. Select Specify on Screen to specify the insertion point after selecting OK, before entering the Block Editor. The coordinates become the 0,0,0 insertion base point for the symbol.

## Inserting Attributes

- 1 Click Schematic tab ► Other Tools panel ► Symbol Builder drop-down

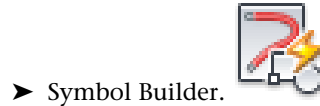

- 2 Select options on the [Select Symbol / Objects](#) on page 342 dialog box.

- 3 Click OK to enter the block editor environment.

- 4 If the Symbol Builder Attribute Editor is not visible, click Symbol Builder



- 5 Select the attribute you want to insert.

- 6  Click the Insert Attribute tool.

---

**NOTE** You can also right-click and select Insert Attribute or drag the attribute to insert it.

---

- 7 Select an insertion point for the attribute.

## Add an attribute to the list

- 1  Select the Add Attribute tool.
- 2 Define the attribute tag and properties on the Insert/Edit Attributes dialog box.

- 3 Click Insert to insert the new attribute or click OK to add it to the list.

## Symbol Builder Attribute Editor

Use the Symbol Builder Attribute Editor to add, modify, and remove attributes on the symbol. Menu sections which differ depending on the symbol type.

 **Ribbon:** Schematic tab ► Other Tools panel ► Symbol Builder

drop-down ► Symbol Builder.



 **Toolbar:** Miscellaneous

 **Menu:** Components ► Symbol Library ► Symbol Builder

 **Command entry:** AESYMBUILDER

- 1 Select options on the [Select Symbol / Objects](#) on page 342 dialog box.
- 2 Click OK to enter the block editor environment.

### Common Tools

The Symbol Builder Attribute Editor provides a few tools that are common to any symbol type.



Opens the [Symbol Configuration](#) on page 344 dialog box with options to change the attribute template.



Opens the [Convert Text to Attribute](#) on page 355 dialog box to map text objects to attributes.



Opens the [Symbol Audit](#) on page 359 dialog box to find any potential issues with the symbol.

---

**NOTE** A right-click menu is available containing functions appropriate for the selected attributes.

---

### Required/Optional Attributes Tools



Insert the selected attributes.

---

**NOTE** You can also drag to insert the selected attributes.

---



Opens the Insert/Edit Attributes dialog box to set the properties for the selected attributes.



Convert existing text objects to the selected attributes.



Add an attribute to the list and define its properties.



Remove the selected attributes from the list.



Delete the selected attributes from the symbol.



Indicates the attribute exists on the symbol.

---

**NOTE** A right-click menu is available containing functions appropriate for the selected attributes.

---

### Wire Connection Tools

Wire connection attributes are inserted based on a style and direction selection. Select the style/direction you want to insert and select the Insert tool. Selecting Others from the Direction/Style list opens the Insert Wire Connection dialog box. Select the style, make it the default, define related pin attribute values, and add multiple wire connections.

Direction/Style

Select from a list of wire connection styles and direction. Select Others to launch the Insert Wire Connections dialog box.



Insert the selected wire connection attribute.

---

**NOTE** A right-click menu is available containing functions appropriate for the selected attributes.

---

### Pin Tools

Pin attributes are added automatically when you add a wire connection attribute. You can also insert them individually. Use this section to add optional wire connection attributes, fill in default attribute values, or change attribute properties.



Opens the Insert/Edit Attributes dialog box to set the properties for the selected attributes.



Convert existing text objects to the selected attributes.



Move a wire connection attribute and its related pin attributes.



Add the optional terminal description attribute to the selected wire connection.



Remove the selected attributes from the list.



Delete the selected attributes from the symbol.

---

**NOTE** A right-click menu is available containing functions appropriate for the selected attributes.

---

### Link Line Tools

Link line attributes are inserted based on a direction selection. Select the direction you want to insert and select the insert tool.

Direction

Select from a list of link line directions.



Insert the selected link line attribute.





Indicates the attribute exists on the symbol.

---

**NOTE** A right-click menu is available containing functions appropriate for the selected attributes.

---

### Rating/Position Tools

AutoCAD Electrical allows up to 12 rating and position attributes. To insert the next available attribute, select the Add Next tool and pick an insertion point.



Add the next attribute to the list and prompt for the insertion point.



Indicates the attribute exists on the symbol.

---

**NOTE** A right-click menu is available containing functions appropriate for the selected attributes.

---

### Insert / Edit Attributes

Use this dialog box to enter default attribute values or modify attribute properties.

 **Ribbon:** Schematic tab ► Other Tools panel ► Symbol Builder

drop-down ► Symbol Builder.



 **Toolbar:** Miscellaneous

 **Menu:** Components ► Symbol Library ► Symbol Builder

 **Command entry:** AESYMBUILDER

- 1 Select options on the [Select Symbol / Objects](#) on page 342 dialog box.
- 2 Click OK to enter the block editor environment.

-  Select an attribute in the grid and click the Property tool, or double-click an attribute in the grid.

---

**NOTE** The Insert button is only available for new attributes added to the list using the Add tool.

---

## Inserting Wire Connections

Symbol Builder inserts a wire connection template drawing when adding a wire connection to your symbol. The list of wire connection options is built dynamically based on the template drawings found in the symbol library path.

- Click Schematic tab ➤ Other Tools panel ➤ Symbol Builder drop-down



- Symbol Builder.

- Select options on the [Select Symbol / Objects](#) on page 342 dialog box.
- Click OK to enter the block editor environment.
- If the Symbol Builder Attribute Editor is not visible, click Symbol Builder



- tab ➤ Edit panel ➤ Palette Visibility Toggle.

- Click the arrow on the Wire Connection section of the Symbol Builder Attribute Editor to expand the wire connection section.
- Click the Direction/Style list to expand the list of wire connection options.
- Select a wire connection.

---

**NOTE** Only the options for the default style are shown in the list. To see other styles, or to change the default style, select Others.

---

-  Click the Insert Wire Connection tool.
- Select an insertion point for the attribute.

---

**NOTE** If the wire connection template contains the optional TERMn and TERMDESCn attributes, they are inserted with the wire connection attribute and added to the Pins section.

---

### Others

Selecting Others on the Wire Connection Direction/Style list opens the Insert Wire Connection dialog box. On the Insert Wire Connection dialog box you can insert multiple wire connection attributes, select from a style other than the default, or change the default style.

- 1 Define the style and direction.
- 2 Enter the number of wire connections.
- 3 (optional) Select an attribute in the Pin Information section and click Convert. Select the text for conversion as prompted.
- 4 (optional) Select an attribute in the Pin Information section and click Delete. The attribute is removed from the list and is not inserted with the wire connection attribute.
- 5 (optional) Select an attribute in the Pin Information section and click Properties to define the properties for the attribute using the Insert/Edit dialog box.

---

**NOTE** Pin attributes added with each wire connection may differ based on symbol type.

---

- 6 Click Insert.
- 7 Select the wire connection attribute insertion points. The related pin attributes are inserted relative to the wire connection attribute based on the wire connection template.

### Insert Wire Connections

Use this dialog box to insert multiple wire connection attributes at a time or to select a style other than the default.

 **Ribbon:** Schematic tab ► Other Tools panel ► Symbol Builder



drop-down ► Symbol Builder.



 **Toolbar:** Miscellaneous

 **Menu:** Components ► Symbol Library ► Symbol Builder

 **Command entry:** AESYMBUILDER

- 1 Select options on the [Select Symbol / Objects](#) on page 342 dialog box.
- 2 Click OK to enter the block editor environment.
- 3 Expand the Wire Connection section and select Others from the Direction/Style list.

### Configuration

<b>Terminal Style</b>	Select the wire connection style from the list. The list is built dynamically based on the wire connection templates in the library folder. Wire connection templates start with “BB”. <hr/> <b>NOTE</b> See <a href="#">Creating a custom wire connection style</a> on page 2107 to add terminal styles. <hr/>
<b>Connection Direction</b>	Select the direction the wire connects from. The direction determines the connection attribute name.
<b>Scale</b>	Enter the insertion scale for the wire connection template.
<b>Use this configuration as default</b>	Use the terminal style as the default in the Direction/Style list in the symbol builder attribute editor. Use the scale value as the default insertion scale for wire connection attributes. Select Apply to save the current settings. Settings are saved automatically when Insert is selected.

### Number and Offset Distance

<b>Number</b>	Enter the number of wire connection attributes to insert.
<b>Select on screen</b>	Select the insertion point for each wire connection after clicking Insert.
<b>Row offset</b>	Enter the X distance between each wire connection.
<b>Column offset</b>	Enter the Y distance between each wire connection.

## Pin Information

<b>Name/Default</b>	List of optional related pin attributes inserted with the wire connection attributes. Modify the default values.
<b>Convert</b>	Dismisses the dialog box. Select a text object for conversion to the selected attribute.
<b>Delete</b>	Removes the selected attributes from the list so they are not inserted with the wire connection attributes.
<b>Properties</b>	Opens the Insert/Edit Attributes dialog box used to define the properties for the selected attributes.

## See also:

- [Wire connection/terminal pin number pairs](#) on page 312

## Inserting Link Line Attributes

AutoCAD Electrical uses invisible attributes to tie in dashed link lines automatically between related components (instead of cross-reference annotation). The attributes are named X?LINK. The "?" is a digit that indicates the preferred link line connection direction.

- 1: connects to the attribute from the right
- 2: connects to the attribute from above
- 4: connects to the attribute from the left
- 8: connects to the attribute from below

- 1 Click Schematic tab ➤ Other Tools panel ➤ Symbol Builder drop-down

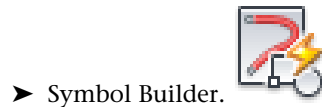

- 2 Select options on the [Select Symbol / Objects](#) on page 342 dialog box.
- 3 Click OK to enter the block editor environment.

- 4 If the Symbol Builder Attribute Editor is not visible, click Symbol Builder

tab ► Edit panel ► Palette Visibility Toggle.



- 5 Click the arrow on the Link Lines section of the Symbol Builder Attribute Editor to expand the section.
- 6 Click the Direction list to expand the list of link line options.
- 7 Select a direction.

- 8  Click the Insert Link Line tool.

- 9 Select an insertion point for the attribute.

## Converting Text

You can convert text objects to attribute definitions on your symbol. The text value becomes the default value for the attribute when the block is inserted on a drawing.

- 1 Click Schematic tab ► Other Tools panel ► Symbol Builder drop-down

► Symbol Builder.



- 2 Select options on the [Select Symbol / Objects](#) on page 342 dialog box making sure to select the existing text objects.
- 3 Click OK to enter the block editor environment.

## Converting a single text object to an attribute definition

- 1 If the Symbol Builder Attribute Editor is not visible, click Symbol Builder

tab ► Edit panel ► Palette Visibility Toggle.



- 2 Select the attribute from the list.

- 3  Click the Convert Text tool at the top of the section for the attribute.

- 4 Select the text object.

### Converting multiple text objects to attribute definitions



- 1 Select the Text Convert tool at the top of the Symbol Builder Attribute Editor to launch the Convert Text to Attribute dialog box.
- 2 Select the text within the Text list.
- 3 Select the arrow next to the attribute name in the Attribute list.
- 4 Repeat for each text object you want to convert.
- 5 Click OK.

### Convert Text to Attribute

 **Ribbon:** Schematic tab ► Other Tools panel ► Symbol Builder

drop-down ► Symbol Builder.



 **Toolbar:** Miscellaneous

 **Menu:** Components ► Symbol Library ► Symbol Builder

 **Command entry:** AESYMBUILDER

- 1 Select options on the [Select Symbol / Objects](#) on page 342 dialog box.
- 2 Click OK to enter the block editor environment.



- 3 Select the Text Convert tool.

If you selected existing text entities, this option converts the existing text entities to AutoCAD Electrical attributes "in place." Use this dialog box to map the text objects to attributes for the selected symbol type.

**Text**

Lists all existing text objects in the symbol.

**Attribute**

Lists attributes from the symbol builder attribute editor grids that do not exist on the symbol.

To convert an existing text object to an attribute, select the text and click the arrow pointing at the attribute. The text string is used as the default value for the attribute and the text object is deleted.

## Saving the Symbol

Once you have added the attributes and completed the symbol graphics, you are ready to save your library symbol. The following steps save your symbol as a .dwg file for insertion on a drawing. They also create an icon image to use when you add this symbol to an icon menu.



- 1 Click Symbol Builder tab ► Edit panel ► Done.  
The Save Symbol dialog box is displayed.
- 2 Select WBlock in the Destination section.
- 3 Modify the block name as needed.
- 4 Modify the wblock File path as needed.
- 5 Specify the base point for symbol insertion.
- 6 Check Icon image to create a .png file. This image file can be used if you add the symbol to the icon menu.

---

**NOTE** The symbol is not automatically added to the icon menu but can be added using the [Icon Menu Wizard](#) on page 1231.

---

- 7 Modify the image name as needed.
- 8 Modify the image File path as needed. The default path is the image folder for the current icon menu.
- 9 Click Details to examine any errors found in the [symbol audit](#) on page 359.
- 10 Click OK to save the symbol.

---

**NOTE** If you close the block editor without saving, the dialog box opens automatically. Select the No button to close the block editor without saving the symbol changes.

---



## See also:

- [Overview of the Icon Menu Wizard](#) on page 1231

## Save Symbol

 **Ribbon:** Schematic tab ► Other Tools panel ► Symbol Builder

drop-down ► Symbol Builder. 

 **Toolbar:** Miscellaneous 

 **Menu:** Components ► Symbol Library ► Symbol Builder

 **Command entry:** AESYMBUILDER

- 1 Select options on the [Select Symbol / Objects](#) on page 342 dialog box.
- 2 Click OK to enter the block editor environment.
- 3 Modify the symbol as needed as described in related topics.

- 4 Click Symbol Builder tab ► Edit panel ► Done. 

The Save Symbol dialog box is displayed.

---

**NOTE** If you close the block editor without saving, this dialog box opens automatically. The No button on this dialog box closes the block editor without saving the symbol changes.

---

## Symbol

### Block/Wblock

Select Block to insert your new component into your drawing or Wblock to save a copy of your new symbol. If Wblock is selected, the File path is available.

---

**NOTE** The Block option is not available if you browsed to an existing symbol on the [Select Symbol / Objects](#) on page 342 dialog box. It is because the drawing file for the library symbol is opened.

---

### Orientation

The first character of the symbol, "H" for horizontal or "V" for vertical.

<b>Catalog name</b>	<p><b>Symbol Name:</b> The next two characters of the symbol name indicate the family type and can match the symbol to a catalog lookup table.</p> <hr/> <p><b>NOTE</b> Schematic terminals use “T1” for a terminal that triggers a wire number change. They use “T0” for a terminal that does not trigger a wire number change.</p> <hr/> <p><b>WDBLKNAM:</b> On a schematic symbol, the WDBLKNAM value overrides the catalog lookup table defined by the second and third characters of the symbol name. The WDBLKNAM value is always used on panel footprint symbols to match the symbol to a catalog lookup table.</p>
<b>Type</b>	The fourth character of the symbol name can be a “1” for a parent symbol, “2” for a child symbol, or user-defined for other symbol types.
<b>Contact</b>	If the symbol is a schematic child, the fifth character is “1” for normally open or “2” for normally closed, otherwise it is user-defined.
<b>Unique identifier</b>	Additional characters added to the symbol name to make it unique.
<b>Symbol name</b>	The symbol file name. Symbol Builder suggests a file name based on the orientation, catalog lookup, type, contact, and unique identifier. Edit the symbol name as needed.
<b>File path</b>	The name of the folder for the symbol. Browse to a folder or enter in the folder name.
<b>Details</b>	Opens the Symbol Audit dialog box to view the specific errors.

### Base point

Enter the base point coordinates for the symbol or select Pick point to select on the drawing. Select Specify on Screen to specify the base point after selecting OK. The coordinates become the insertion base point for the symbol.

### Image

<b>Icon image</b>	Create an image to use if you add this new symbol to an icon menu.
-------------------	--

See Also: [Overview of the Icon Menu Wizard](#) on page 1231

<b>Name</b>	The image file name. Image files are created as a .png file type.
<b>File path</b>	The name of the folder for the image file. Browse to a folder or enter in the folder name.

## See also:

- [Overview of symbol naming conventions](#) on page 282

## Symbol Audit

This dialog box provides audit information on the attributes and symbol name. The audit information is based on the symbol type.

 **Ribbon:** Schematic tab ► Other Tools panel ► Symbol Builder

drop-down ► Symbol Builder.

 **Toolbar:** Miscellaneous

 **Menu:** Components ► Symbol Library ► Symbol Builder

 **Command entry:** AESYMBUILDER

- 1 Select options on the [Select Symbol / Objects](#) on page 342 dialog box.
- 2 Click OK to enter the block editor environment.
- 3 Add attributes as needed.

- 4  Select the Audit tool.

The tree structure lists categories of errors found on the symbol. The number of errors for each category is displayed in parentheses or, (OK) if no errors exist within the category.

**Missing required attributes** Lists attributes that are in the required group, based on the attribute template, but are not present on the symbol.

**Duplicated attributes** Lists attributes with duplicated tags present on the symbol.

<b>Missing values</b>	Lists attributes with default values defined on the attribute template but are missing on the attributes on the symbol.
<b>Missing prompts</b>	Lists attributes with default prompts defined on the attribute template but are missing on the attributes on the symbol.
<b>Missing group attributes</b>	Lists attributes missing from common groups, such as MFG, CAT, ASSYCODE.
<b>Template mismatch</b>	Lists the attributes on the attribute template but removed from the list.
<b>Layers</b>	Lists layers other than 0 containing entities.
<b>Insertion point</b>	This error condition exists if neither the X or Y value of the insertion point matches the insertion point of at least one of the wire connection attributes.
<b>Orientation</b>	This error condition exists for a horizontal symbol without left or right wire connection attributes. It also exists for a vertical symbol without top or bottom wire connection attributes.

Select **Save As** to save the error information as an .xml file for reference.





# Symbol Preview Guide





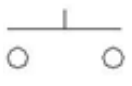



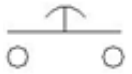
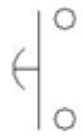

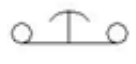

# JIC Symbols

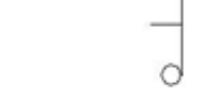
# 6

## Push Buttons

Horizontal Symbol	Vertical Symbol	Description
 HPB11	 VPB11	Push Button Normally Open
 HPB12	 VPB12	Push Button Normally Closed
 HPB11M	 VPB11M	Mushroom Head Normally Open

		Mushroom Head Normally Closed
HPB12M	VPB12M	
		Illuminated Push Button Normally Open
HPB11L	VPB11L	
		Illuminated Push Button Normally Closed
HPB12L	VPB12L	
		Illuminated Mushroom Head Normally Open
HPB11ML	VPB11ML	
		Illuminated Mushroom Head Normally Closed
HPB12ML	VPB12ML	
		2nd+ Normally Open Contact
HPB21	VPB21	





**HPB22**



**VPB22**

2nd+ Normally Closed Contact



**HPB2R**



**VPB2R**

2nd+ Red Light



**HPB2G**



**VPB2G**

2nd+ Green Light



**HPB2A**



**VPB2A**

2nd+ Amber Light



**HPB2Y**



**VPB2Y**

2nd+ Yellow Light



**HPB2B**



**VPB2B**

2nd+ Blue Light



HPB2W



VPB2W

2nd+ White Light



HPB2C



VPB2C

2nd+ Clear Light

**NOTE** Lights will receive text to indicate the color at the time of insertion.

## Selector Switches

### Selector Switches

Horizontal Symbol	Vertical Symbol	Description
		2 Position Maintain, Normally Open
		2 Position Maintain, Normally Closed

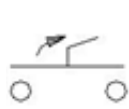

**HSS112L**



**VSS112L**

2 Position Normally Open Return From Left

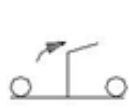

**HSS122L**



**VSS122L**

2 Position Normally Closed Return From Left

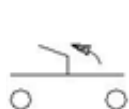

**HSS112R**



**VSS112R**

2 Position Normally Open Return From Right



**HSS122R**



**VSS122R**

2 Position Normally Closed Return From Right

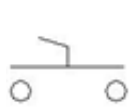

**HSS113**



**VSS113**

3 Position Normally Open



**HSS123**



**VSS123**

3 Position Normally Closed

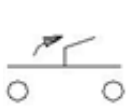

**HSS113L**



**VSS113L**

3 Position Normally Open Return From Left



**HSS123L**



**VSS123L**

3 Position Normally Closed Return From Left

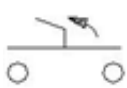

**HSS113R**



**VSS113R**

3 Position Normally Open Return From Right



**HSS123R**



**VSS123R**

3 Position Normally Closed Return From Right

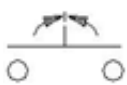

**HSS113B**



**VSS113B**

3 Position Normally Open Return From Both

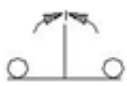

**HSS123B**



**VSS123B**

3 Position Normally Closed Return From Both

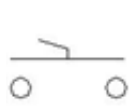

**HSS114**



**VSS114**

4 Position Normally Open

---



**HSS124**



**VSS124**

4 Position Normally Closed

---



**HSS116**



**VSS116**

6 Position Normally Open

---



**HSS126**



**VSS126**

6 Position Normally Closed

---



**HSS118**



**VSS118**

8 Position Normally Open

---



**HSS128**





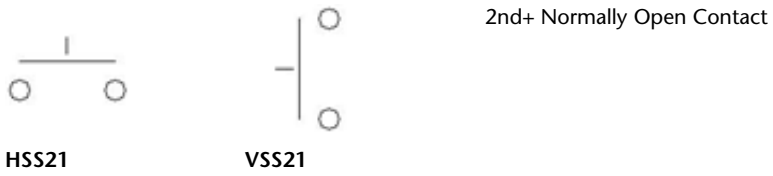

**VSS128**

8 Position Normally Closed

---

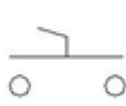
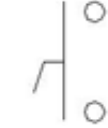

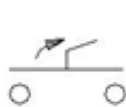
## Illuminated Selector Switches

Horizontal Symbol	Vertical Symbol	Description
		2 Position Normally Open
<b>HSS1121</b>	<b>VSS1121</b>	
		2 Position Normally Closed
<b>HSS1221</b>	<b>VSS1221</b>	
		2 Position Normally Open Return From Left
<b>HSS112LI</b>	<b>VSS112LI</b>	

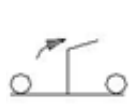

**HSS122LI**



**VSS122LI**

2 Position Normally Closed Return From Left

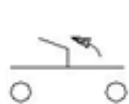

**HSS112RI**



**VSS112RI**

2 Position Normally Open Return From Right



**HSS122RI**



**VSS122RI**

2 Position Normally Closed Return From Right

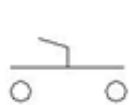

**HSS113I**



**VSS113I**

3 Position Normally Open



**HSS123I**



**VSS123I**

3 Position Normally Closed

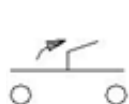

**HSS113LI**



**VSS113LI**

3 Position Normally Open Return From Left

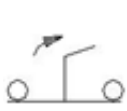

**HSS123LI**



**VSS123LI**

3 Position Normally Closed Return From Left

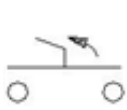

**HSS113RI**



**VSS113RI**

3 Position Normally Open Return From Right



**HSS123RI**



**VSS123RI**

3 Position Normally Closed Return From Right

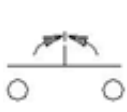

**HSS113BI**



**VSS113BI**

3 Position Normally Open Return From Both

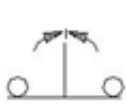

**HSS123BI**



**VSS123BI**

3 Position Normally Closed Return From Both



**HSS2R**



**VSS2R**

Red Light





**HSS2G**



**VSS2G**

Green Light

---



**HSS2A**



**VSS2A**

Amber Light

---



**HSS2Y**



**VSS2Y**

Yellow Light

---



**HSS2B**



**VSS2B**

Blue Light

---



**HSS2W**



**VSS2W**

White Light

---



**HSS2C**













**VSS2C**

Clear Light

---

# Fuses, Circuit Breakers, Transformers

## Fuses and Transformers

Horizontal Symbol	Vertical Symbol	Description
		Fuse (Tag)
<b>HFU1</b>	<b>VFU1</b>	
		Fuse
<b>HFU0</b>	<b>VFU0</b>	
		2nd+ Fuse
<b>HFU2</b>	<b>VFU2</b>	
		Fuse Switch (Right)
<b>HDS11FR</b>	<b>VDS11FR</b>	
		Fuse Switch (Left)
<b>HDS11FL</b>	<b>VDS11FL</b>	

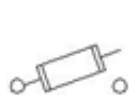

**HDS21FR**



**VDS21FR**

2nd+ Fuse Switch(Right)



**HDS21FL**



**VDS21FL**

2nd+ Fuse Switch (Left)



**HXF1**



**VXF1**

Transformer



**HXF1D**



**VXF1D**

Transformer Dual

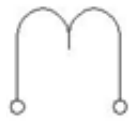

**HXF1CT**



**VXF1CT**

Circuit Transformer

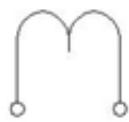









**HXF1PT**

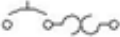

**VXF1PT**

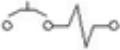
Potential Transformer

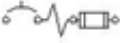
## Circuit Breakers and Disconnects

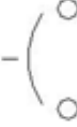
Horizontal Symbol	Vertical Symbol	Description
 <b>HCB1</b>	 <b>VCB1</b>	Circuit Breaker 1 Pole
 <b>HCB11TH</b>	 <b>VCB11TH</b>	Thermal Circuit Breaker
 <b>HCB11M</b>	 <b>VCB11M</b>	Motor Circuit Protector
 <b>HCB11ML</b>	 <b>VCB11ML</b>	Motor Circuit Protector with Fuse
 <b>HCB2</b>	 <b>VCB2</b>	2nd+ Circuit Breaker 1 Pole

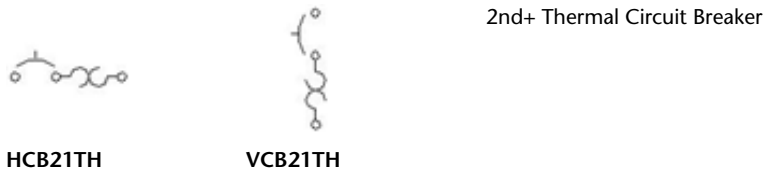

2nd+ Thermal Circuit Breaker

**HCB21TH**

**VCB21TH**



2nd+ Motor Circuit Protector

**HCB21M**

**VCB21M**

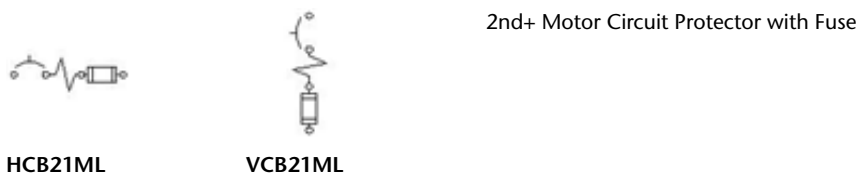

2nd+ Motor Circuit Protector with Fuse

**HCB21ML**

**VCB21ML**

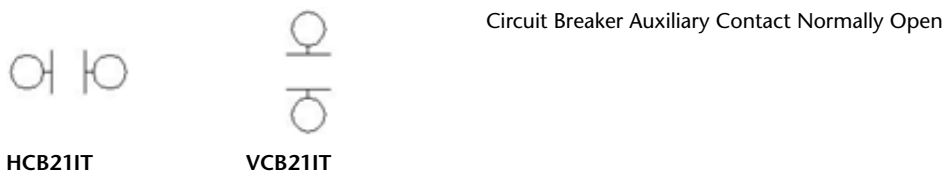

Circuit Breaker Auxiliary Contact Normally Open

**HCB21IT**

**VCB21IT**



Disconnect Switch

**HDS11**

**VDS11**

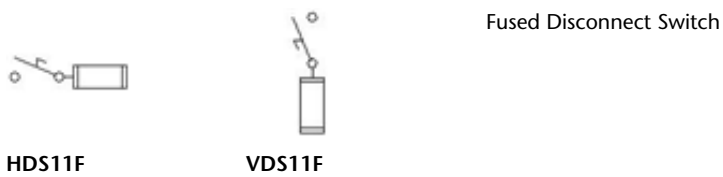

Fused Disconnect Switch

**HDS11F**

**VDS11F**

Disconnect Switch Auxiliary Contact Normally Open

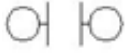

HDS21IT

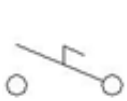

HDS21



VDS21

2nd+ Disconnect Switch

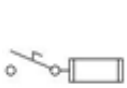

HDS21F

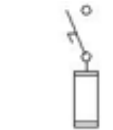

VDS21F

2nd+ Fused Disconnect Switch

## Relays and Contacts

### Relays and Contacts

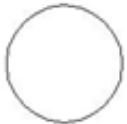
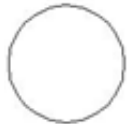
Horizontal Symbol	Vertical Symbol	Description
		Relay Coil
HCR1	VCR1	

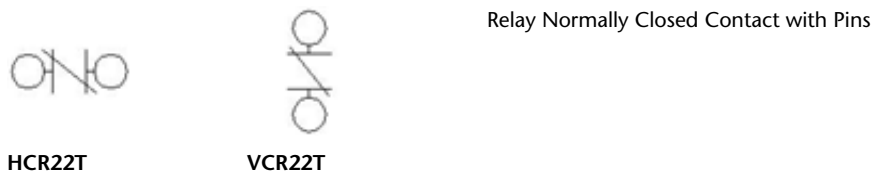
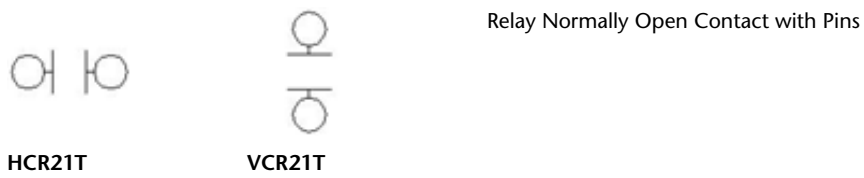
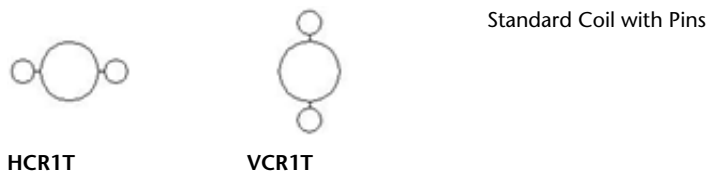
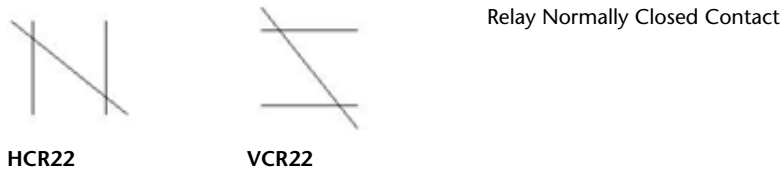
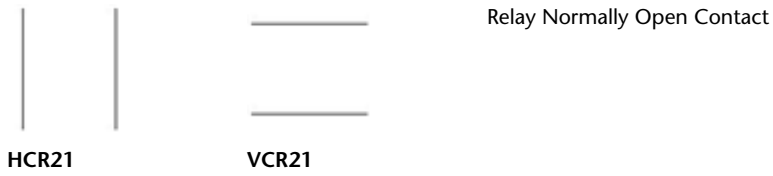

## Latch Relay Coils

Horizontal Symbol	Vertical Symbol	Description
-------------------	-----------------	-------------

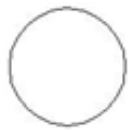

**HLR1**

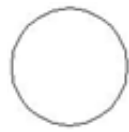

**VLR1**

Latch Relay Coil



**HLR1T**

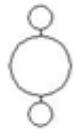

**VLR1T**

Latch Relay Coil with pins

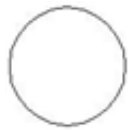

**HLR1U**

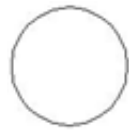

**VLR1U**

UnLatch Relay Coil



**HLR1UT**



**VLR1UT**

UnLatch Relay Coil with pins

## Timers

### Time Delay Relays

Horizontal Symbol	Vertical Symbol	Description
-------------------	-----------------	-------------



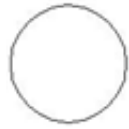

**HTD1N**

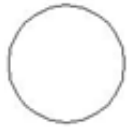

**VTD1N**

ON Delay Coil



**HTD1NT**



**VTD1NT**

ON Delay Coil with Pins

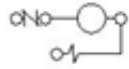

**HTD1NM**

ON Delay Starter



**HTD21N**

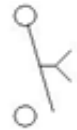

**VTD21N**

ON Delay Normally Open - TC



**HTD22N**



**VTD22N**

ON Delay Normally Closed - TO

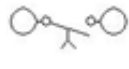

**HTD21NT**

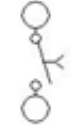

**VTD21NT**

ON Delay Normally Open - TC with Pins

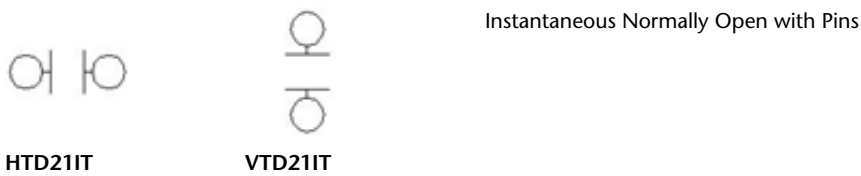
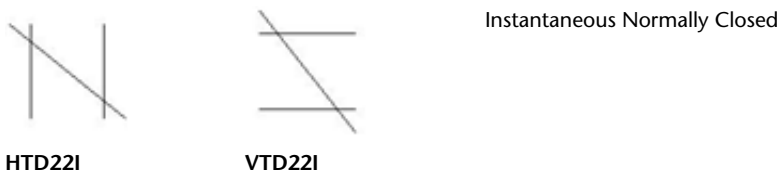

## OFF-Delay Timers

Horizontal Symbol	Vertical Symbol	Description
-------------------	-----------------	-------------

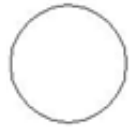

**HTD1F**

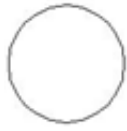

**VTD1F**

OFF Delay Coil



**HTD1FT**



**VTD1FT**

OFF Delay Coil with Pins

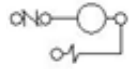

**HTD1FM**

OFF Delay Starter

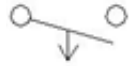

**HTD21F**

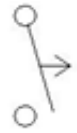

**VTD21F**

OFF Delay Normally Open-TO

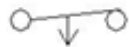

**HTD22F**



**VTD22F**

OFF Delay Normally Closed-TC

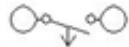

**HTD21FT**

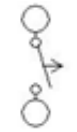

**VTD21FT**

OFF Delay Normally Open-TO with Pins

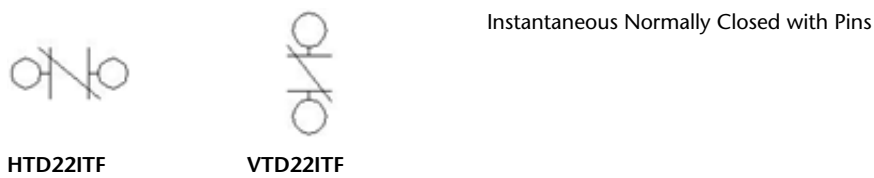
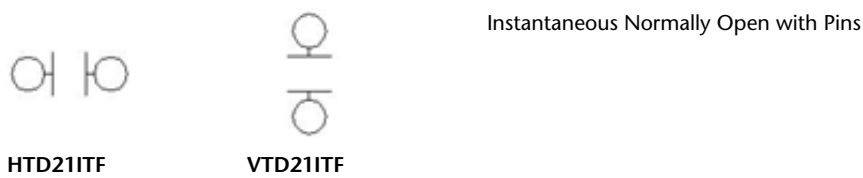
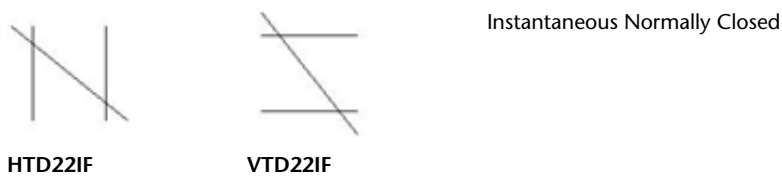

## Motor Control

Horizontal Symbol	Vertical Symbol	Description
-------------------	-----------------	-------------

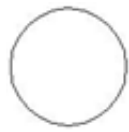

HMS1

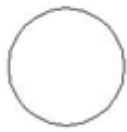

VMS1

Motor Starter Coil



HMS1T



VMS1T

Motor Starter Coil with Pins



HOL11



VOL11

Overload

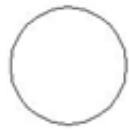

HMO13

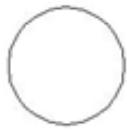

VMO13

3 Phase Motor



HMS21



VMS21

2nd+ Starter Contact Normally Open

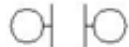

HMS21T

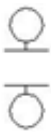

VMS21T

2nd+ Starter Contact Normally Open with Pins

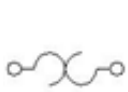

**HOL21**



**VOL21**

2nd+ Overload

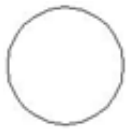

**HMO12**

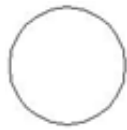

**VMO12**

1 Phase Motor



**HMS22**



**VMS22**

2nd+ Starter Contact Normally Closed

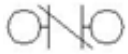

**HMS22T**



**VMS22T**

2nd+ Starter Contact Normally Closed with Pins



**HOL21I**



**VOL21I**

2nd+ Overload Contact Normally Open



**HOL22I**



**VOL22I**

2nd+ Overload Contact Normally Closed

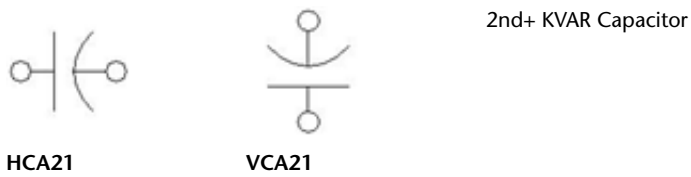
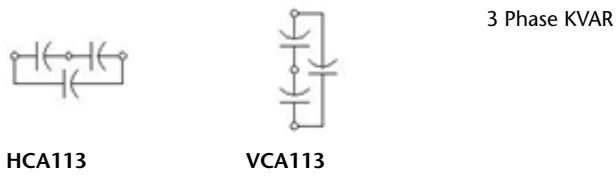
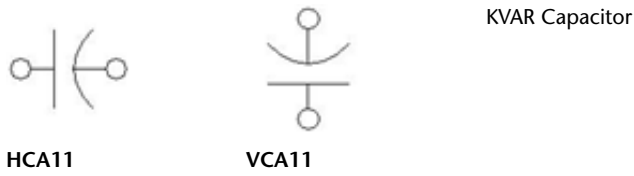

**NOTE** Multi-pole devices are constructed using parent and child symbols to adhere to the underlying ladder spacing.

## Pilot Lights

### Pilot Lights

Horizontal Symbol	Vertical Symbol	Description
		Red Standard
HLT1R	VLT1R	



**HLT1G**



**VLT1G**

Green Standard

---



**HLT1A**



**VLT1A**

Amber Standard

---



**HLT1Y**



**VLT1Y**

Yellow Standard

---



**HLT1B**



**VLT1B**

Blue Standard

---



**HLT1W**



**VLT1W**

White Standard

---



**HLT1C**



**VLT1C**

Clear Standard

---





**HLT1RP**



**VLT1RP**

Red Press To Test

---



**HLT1GP**



**VLT1GP**

Green Press To Test

---



**HLT1AP**



**VLT1AP**

Amber Press To Test

---



**HLT1YP**

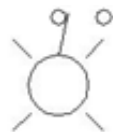

**VLT1YP**

Yellow Press To Test

---



**HLT1BP**

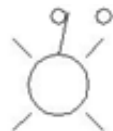

**VLT1BP**

Blue Press To Test

---



**HLT1WP**



**VLT1WP**

White Press To Test

---



HLT1CP



VLT1CP

Clear Press To Test

---

**NOTE** Lights receive text to indicate the color at the time of insertion.

---

## Master Test Pilot Lights

---

Horizontal Symbol	Vertical Symbol	Description
A circular symbol with five radiating lines. A horizontal line extends from the left side of the circle.	A circular symbol with five radiating lines. A vertical line extends from the top of the circle.	Red Master Test
A circular symbol with five radiating lines. A horizontal line extends from the left side of the circle.	A circular symbol with five radiating lines. A vertical line extends from the top of the circle.	Green Master Test
A circular symbol with five radiating lines. A horizontal line extends from the left side of the circle.	A circular symbol with five radiating lines. A vertical line extends from the top of the circle.	Amber Master Test
A circular symbol with five radiating lines. A horizontal line extends from the left side of the circle.	A circular symbol with five radiating lines. A vertical line extends from the top of the circle.	Yellow Master Test

---



**HLT1BM**



**VLT1BM**

Blue Master Test



**HLT1WM**



**VLT1WM**

White Master Test



**HLT1CM**



**VLT1CM**

Clear Master Test

**NOTE** Lights receive text to indicate the color at the time of insertion.

## Neon Pilot Lights

Horizontal Symbol	Vertical Symbol	Description
		Red Standard
		Amber Standard

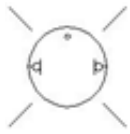

HLT1CN

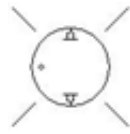

VLT1CN

Clear Standard

---

**NOTE** Lights receive text to indicate the color at the time of insertion.

---





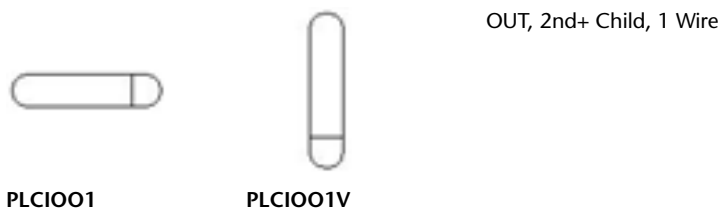
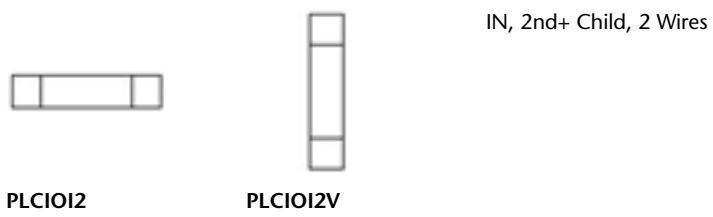
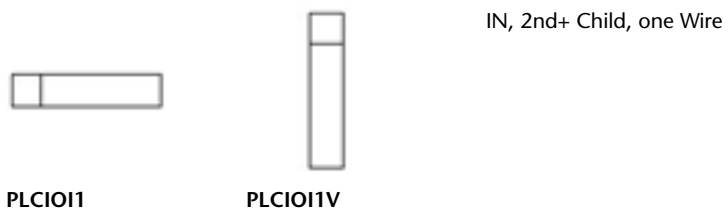
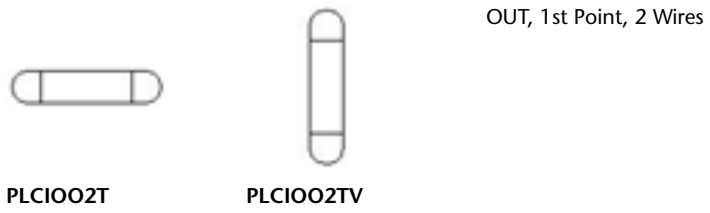





## PLC I/O

Horizontal Symbol	Vertical Symbol	Description
		IN, 1st Point, 1 Wire
<p>PLCIO1T</p>	<p>PLCIO1TV</p>	
		IN, 1st Point, 2 Wires
<p>PLCIO2T</p>	<p>PLCIO2TV</p>	
		OUT, 1st Point, 1 Wire
<p>PLCIO01T</p>	<p>PLCIO01TV</p>	



# Terminals and Connectors

## Terminals

Horizontal Symbol	Vertical Symbol	Description
 <b>HT0_01</b>	 <b>VT0_01</b>	Square
 <b>HT0W01</b>	 <b>VT0W01</b>	Square with Wire Number
 <b>HT0001</b>	 <b>VT0001</b>	Square with Terminal Number
 <b>HT1001</b>	 <b>VT1001</b>	Square with Wire Number Change
 <b>HT0_02</b>	 <b>VT0_02</b>	Round

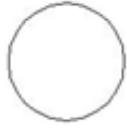

**HT0W02**

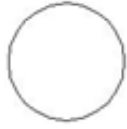

**VT0W02**

Round with Wire Number

---

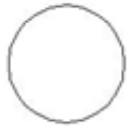

**HT0002**

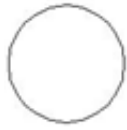

**VT0002**

Round with Terminal Number

---



**HT1002**

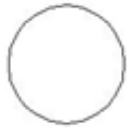

**VT1002**

Round with Wire Number Change

---



**HT0\_03**



**VT0\_03**

Hexagon

---



**HT0W03**



**VT0W03**

Hexagon with Wire Number

---



**HT0003**



**VT0003**

Hexagon with Terminal Number

---



**HT1003**



**VT1003**

Hexagon with Wire Number Change



**HT0\_04**



**VT0\_04**

Diamond



**HT0W04**



**VT0W04**

Diamond with Wire Number



**HT0004**



**VT0004**

Diamond with Terminal Number



**HT1004**



**VT1004**

Diamond with Wire Number Change



**HT0\_05**

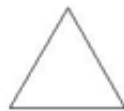

**VT0\_05**

Triangle



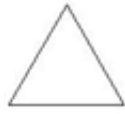

HT0W05

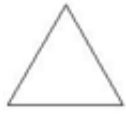

VT0W05

Triangle with Wire Number

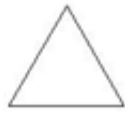

HT0005

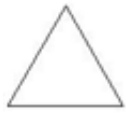

VT0005

Triangle with Terminal Number

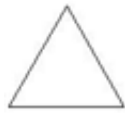

HT1005

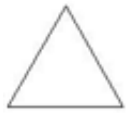

VT1005

Triangle with Wire Number Change







## In-Line Wire Labels

Horizontal Symbol	Vertical Symbol	Description
		In-Line Wire Label
HT0_LGENER- IC	VT0_LGENER- IC	

HTO\_WGENER-  
IC









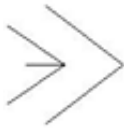

VTO\_WGENER-  
IC

## Power Distribution Blocks

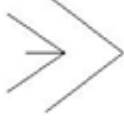
Horizontal Symbol	Vertical Symbol	Description
		3 Terminal, 0.5 Spacing
<b>HDB1350</b>	<b>VDB1350</b>	
		3 Terminal, 0.75 Spacing
<b>HDB1375</b>	<b>VDB1375</b>	
		3 Terminal, 1.0 Spacing
<b>HDB13100</b>	<b>VDB13100</b>	

## Connectors - No Wirenumber Changes

### Connectors - No Wirenumber Changes

Horizontal Symbol	Vertical Symbol	Description
		Plug/Jack
<b>HC01PJ</b>	<b>VC01PJ</b>	
		Jack/Plug
<b>HC01JP</b>	<b>VC01JP</b>	
		Plug/Jack (Combined Tag-Pin)
<b>HC01PJ1</b>	<b>VC01PJ1</b>	
		Jack/Plug (Combined Tag-Pin)
<b>HC01JP1</b>	<b>VC01JP1</b>	
		2nd+ Plug/Jack
<b>HC02PJ</b>	<b>VC02PJ</b>	



HC02JP



VC02JP

2nd+ Jack/Plug

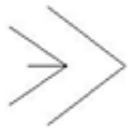

HC02PJ1



VC02PJ1

2nd+ Plug/Jack (Combined Tag-Pin)







HC02JP1



VC02JP1

2nd+ Jack/Plug (Combined Tag-Pin)

## Connectors - No Wirenumber Changes - Spare/Single Side

Horizontal Symbol	Vertical Symbol	Description
		Plug Right or up
HC01P_	VC01P_	
		Jack Left or Down
HC01_J	VC01_J	

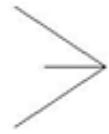

HC01P\_1



VC01P\_1

Plug Right or up (Combined tag/pin)



HC01\_J1



VC01\_J1

Jack Left or Down (Combined)



HC02P\_



VC02P\_

2nd+ Plug Right or up



HC02\_J



VC02\_J

2nd+ Jack Left or Down



HC02P\_1



VC02P\_1

2nd+ Plug Right or up (Combined)

















HC02\_J1





VC02\_J1

2nd+ Jack Left or Down (Combined)





		Jack Right or up
HC01J_	VC01J_	
		Plug Left or Down
HC01_P	VC01_P	
		Jack Right or up (Combined)
HC01J_1	VC01J_1	
		Plug Left or Down (Combined)
HC01_P1	VC01_P1	
		2nd+ Jack Right or up
HC02J_	VC02J_	
		2nd+ Plug Left or Down
HC02_P	VC02_P	

		2nd+ Jack Right or up (Combined)
HC02J_1	VC02J_1	

		2nd+ Plug Left or Down (Combined)
HC02_P1	VC02_P1	





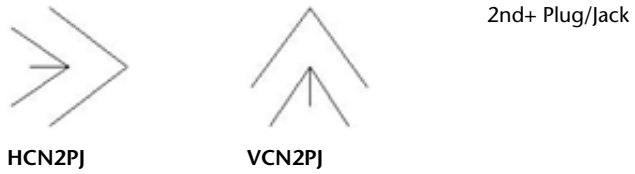

## Connectors - Wirenumber Changes

### Connectors - Wirenumber Changes

Horizontal Symbol	Vertical Symbol	Description
		Plug/Jack
HCN1PJ	VCN1PJ	
		Jack/Plug
HCN1JP	VCN1JP	









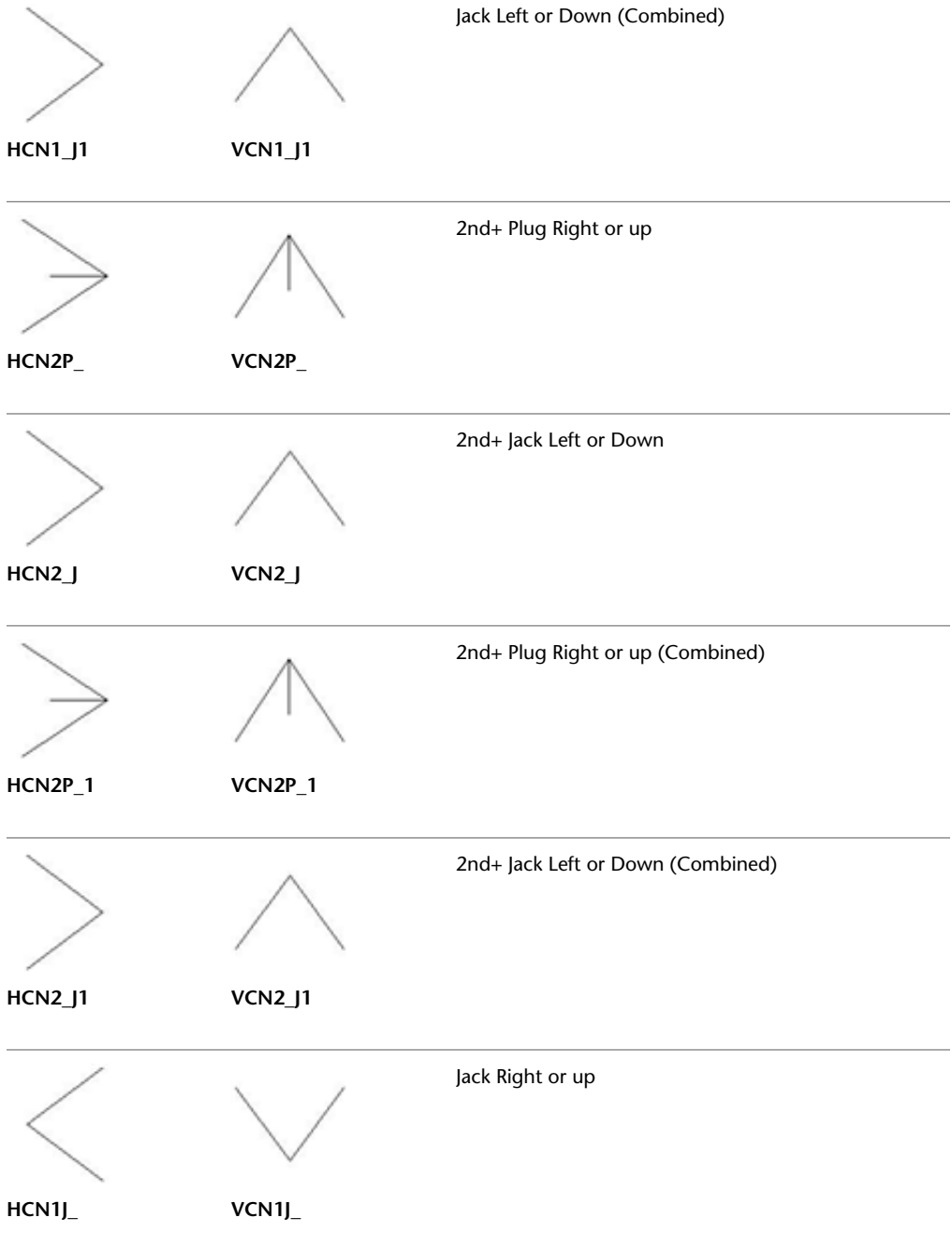





### Connectors - Wirenumber Changes - Spare/Single Side

Horizontal Symbol	Vertical Symbol	Description
		Plug Right or up
<b>HCN1P_</b>	<b>VCN1P_</b>	
		Jack Left or Down
<b>HCN1_J</b>	<b>VCN1_J</b>	
		Plug Right or up (Combined tag/pin)
<b>HCN1P_1</b>	<b>VCN1P_1</b>	





		Plug Left or Down
<b>HCN1_P</b>	<b>VCN1_P</b>	
		Jack Right or up (Combined)
<b>HCN1J_1</b>	<b>VCN1J_1</b>	
		Plug Left or Down (Combined)
<b>HCN1_P1</b>	<b>VCN1_P1</b>	
		2nd+ Jack Right or up
<b>HCN2_</b>	<b>VCN2_</b>	
		2nd+ Plug Left or Down
<b>HCN2_P</b>	<b>VCN2_P</b>	
		2nd+ Jack Right or up (Combined)
<b>HCN2J_1</b>	<b>VCN2J_1</b>	



HCN2\_P1



VCN2\_P1

2nd+ Plug Left or Down (Combined)

## Limit Switches

Horizontal Symbol	Vertical Symbol	Description
		Limit Switch Normally Open
		Limit Switch Normally Closed
		Limit Switch Normally Open Held Closed
		Limit Switch Normally Closed Held Open

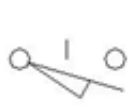

HLS21



VLS21

2nd+ Normally Open Contact



HLS22

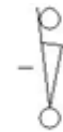

VLS22

2nd+ Normally Closed Contact



HLS21H



VLS21H

2nd+ Normally Open Contact Held Closed

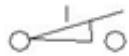

HLS22H



VLS22H

2nd+ Normally Closed Contact Held Open

## Pressure and Temperature Switches

Horizontal Symbol	Vertical Symbol	Description
		Pressure Switch, Normally Open
HPS11	VPS11	

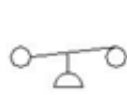

**HPS12**

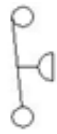

**VPS12**

Pressure Switch, Normally Closed



**HTS11**



**VTS11**

Temperature Switch, Normally Open



**HTS12**



**VTS12**

Temperature Switch, Normally Closed



**HPS21**

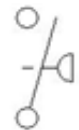

**VPS21**

2nd+ Pressure Normally Open Contact

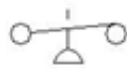

**HPS22**

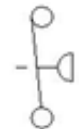

**VPS22**

2nd+ Pressure Normally Closed Contact



**HTS21**

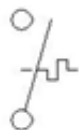

**VTS21**

2nd+ Temperature Normally Open Contact

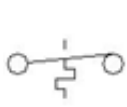

HTS22



VTS22

2nd+ Temperature Normally Closed Contact

## Flow and Level Switches

Horizontal Symbol	Vertical Symbol	Description
		Flow Switch Normally Open
		Flow Switch Normally Closed
		Level Switch Normally Open
		Level Switch Normally Closed

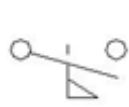

HFS21



VFS21

2nd+ Flow Normally Open Contact



HFS22



VFS22

2nd+ Flow Normally Closed Contact

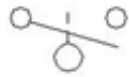

HFL21



VFL21

2nd+ Level Normally Open Contact

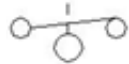

HFL22

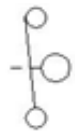

VFL22

2nd+ Level Normally Closed Contact

## Miscellaneous Switches

### Miscellaneous Switches

Horizontal Symbol	Vertical Symbol	Description
-------------------	-----------------	-------------



**HPX11**

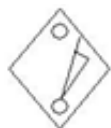

**VPX11**

Proximity Switch Normally Open



**HPX12**



**VPX12**

Proximity Switch Normally Closed



**HPX21**



**VPX21**

2nd+ Proximity Normally Open Contact



**HPX22**



**VPX22**

2nd+ Proximity Normally Closed Contact

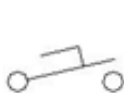

**HFT11**



**VFT11**

Foot Switch Normally Open



**HFT12**



**VFT12**

Foot Switch Normally Closed





2nd+ Foot Normally Open Contact



2nd+ Foot Normally Closed Contact

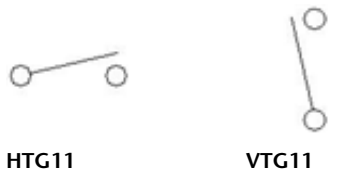

Toggle Switch Normally Open

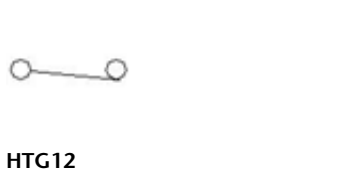

Toggle Switch Normally Closed



2nd+ Toggle Normally Open Contact

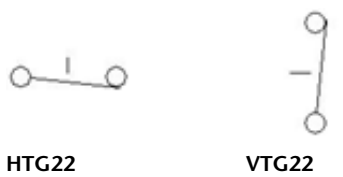

2nd+ Toggle Normally Closed Contact

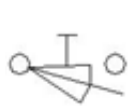

**HPC11**



**VPC11**

Pull cord Switch Normally Open

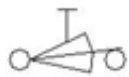

**HPC12**



**VPC12**

Pull cord Switch Normally Closed



**HPC21**



**VPC21**

2nd+ Pull Cord Normally Open Contact

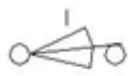

**HPC22**



**VPC22**

2nd+ Pull Cord Normally Closed Contact



**HPG11**

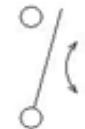

**VPG11**

A-Plug Normally Open



**HPG12**



**VPG12**

A-Plug Normally Closed

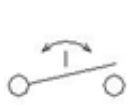

HPG21



VPG21

2nd+ A-Plug Normally Open Contact



HPG22

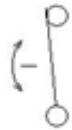

VPG22

2nd+ A-Plug Normally Closed Contact



HPE11



VPE11

Photo Eye Switch Normally Open



HPE12



VPE12

Photo Eye Switch Normally Closed

## Single Pole Double Throw Switches

Horizontal Symbol	Vertical Symbol	Description
		Single Pole Double Throw Maintained
HTG112	VTG112	

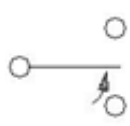

**HTG112D**



**VTG112D**

Single Pole Double Throw Return From Down

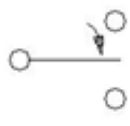

**HTG112U**



**VTG112U**

Single Pole Double Throw Return From Up

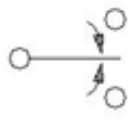

**HTG112B**



**VTG112B**

Single Pole Double Throw Return From Both



**HTG212**



**VTG212**

2nd+ Maintained

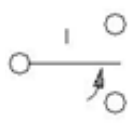

**HTG212D**



**VTG212D**

2nd+ Return From Down

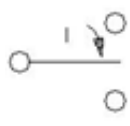

**HTG212U**



**VTG212U**

2nd+ Return From Up



**HTG212B**



**VTG212B**

2nd+ Return From Both

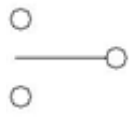

**HTG112R**

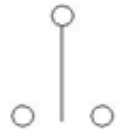

**VTG112R**

Single Pole Double Throw Maintained

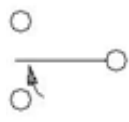

**HTG112DR**



**VTG112DR**

Single Pole Double Throw Return From Down

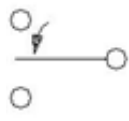

**HTG112UR**



**VTG112UR**

Single Pole Double Throw Return From Up

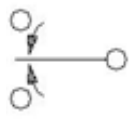

**HTG112BR**



**VTG112BR**

Single Pole Double Throw Return From Both

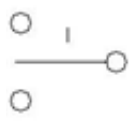

**HTG212R**

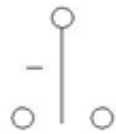

**VTG212R**

2nd+ Maintained

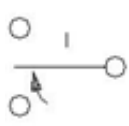

HTG212DR



VTG212DR

2nd+ Return From Down



HTG212UR



VTG212UR

2nd+ Return From Up

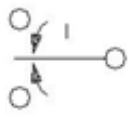



HTG212BR



VTG212BR



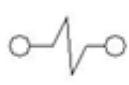
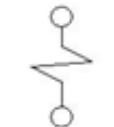
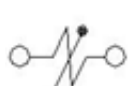

2nd+ Return From Both

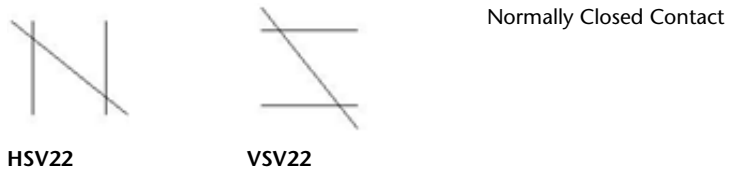
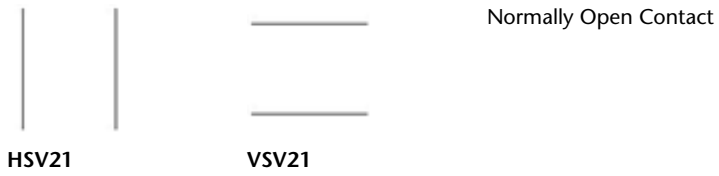
## Solenoids

Horizontal Symbol	Vertical Symbol	Description
		Solenoid
<p>HSV1</p>	<p>VSV1</p>	
		Manual Reset Solenoid
<p>HSV1M</p>	<p>VSV1M</p>	

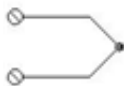

## Instrumentation

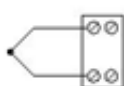
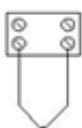

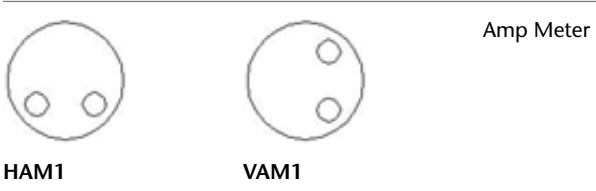
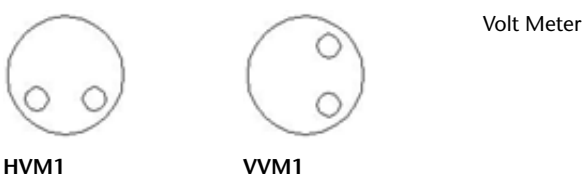
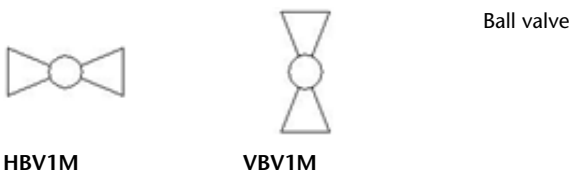
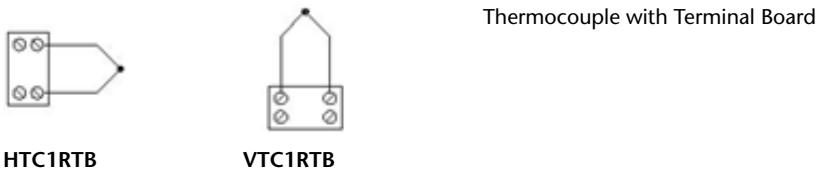





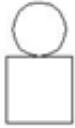

Horizontal Symbol	Vertical Symbol	Description
		Thermocouple
<b>HTC1L</b>	<b>VTC1L</b>	
		Thermocouple
<b>HTC1R</b>	<b>VTC1R</b>	
		Thermocouple with Terminal Board
<b>HTC1LTB</b>	<b>VTC1LTB</b>	

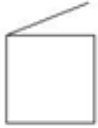









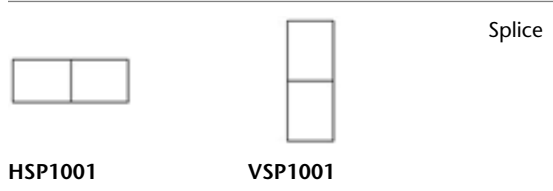
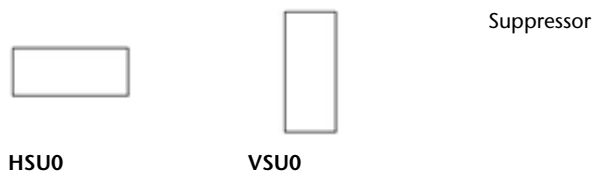
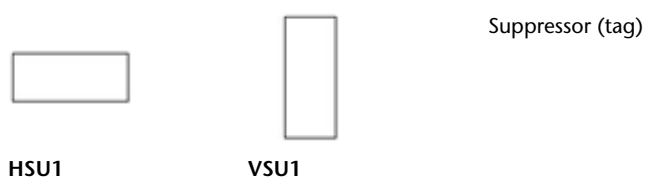



## Miscellaneous

### Miscellaneous

Horizontal Symbol	Vertical Symbol	Description
 HAN1B	 VAN1B	Bell
 HAN1Z	 VAN1Z	Buzzer
 HAN1H	 VAN1H	Horn
 HGND2	 VGND2	Ground
 HGND1	 VGND1	Earth/Ground



## Electronics

Horizontal Symbol	Vertical Symbol	Description
		Fixed Resistor
<b>HRE1</b>	<b>VRE1</b>	
		Fixed Resistor (Box)
<b>HRE1B</b>	<b>VRE1B</b>	
		Fixed Resistor with Pins
<b>HRE1T</b>	<b>VRE1T</b>	
		Fixed Resistor (Box) with Pins
<b>HRE1TB</b>	<b>VRE1TB</b>	
		Variable Resistor
<b>HVR1TZ</b>	<b>VVR1TZ</b>	

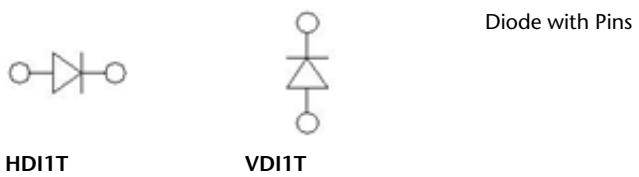
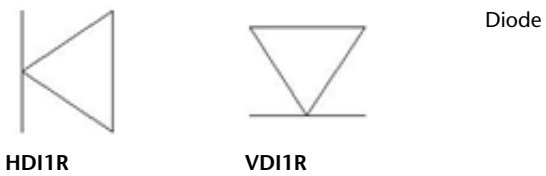
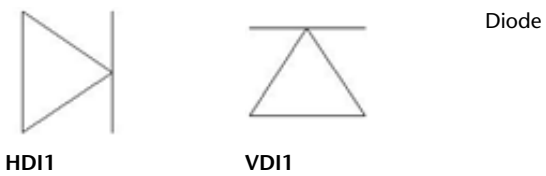
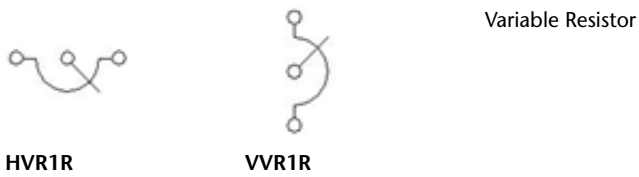
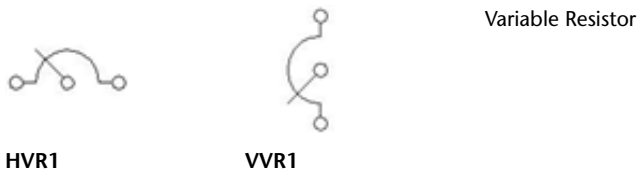

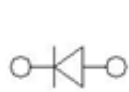

**HDI1TR**



**VDI1TR**

Diode with Pins



**HDI1Z**

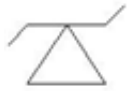

**VDI1Z**

Zener Diode



**HDI1ZR**



**VDI1ZR**

Zener Diode



**HDI1TZ**

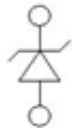

**VDI1TZ**

Zener Diode with Pins



**HDI1TZR**

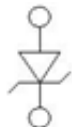

**VDI1TZR**

Zener Diode with Pins



**HCA1**



**VCA1**

Capacitor



HCA1T







VCA1T

Capacitor with Pins



## Cable Markers

Horizontal Symbol	Vertical Symbol	Description
		Cable Marker
HW01	VW01	
		2nd+ Child Marker
HW02	VW02	
		Extra Marker
HTO_CABLE	VT0_CABLE	
		Twisted Pair
HTO_TW	VT0_TW	

## Power Receptacles

Horizontal Symbol	Vertical Symbol	Description
		Duplex Receptacle
<b>HCN1RDUP</b>	<b>VCN1RDUP</b>	
		Single Receptacle
<b>HCN1RSGL</b>	<b>VCN1RSGL</b>	

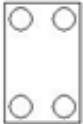
## Generic Device Boxes

Horizontal Symbol	Vertical Symbol	Description
		4 Terminals
<b>HDV1TFL</b>	<b>VDV1TFL</b>	
		3 Terminals
<b>HDV1TC</b>	<b>VDV1TC</b>	

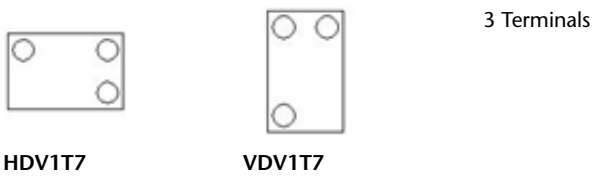
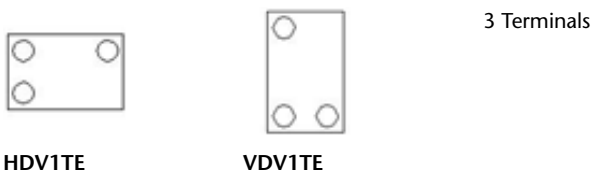
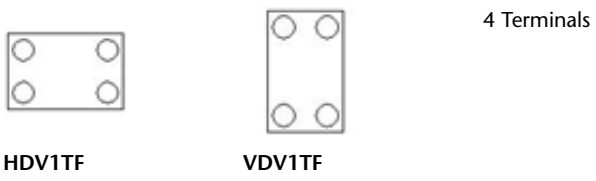
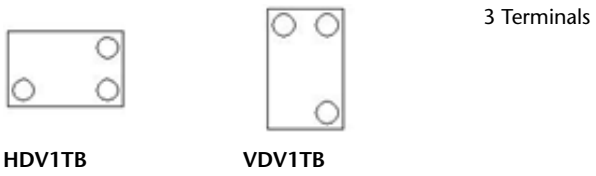

## Stand-alone Cross-reference Symbols

Symbol	Description
--------	-------------



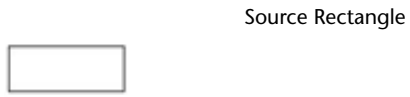

Source Rectangle

**HA2S1\_REF**

---



Source Hexagon

**HA3S1\_REF**

---



Source Ellipse

**HAS1\_REF**

---



Destination Rectangle

**HA2D1\_REF**

---



Destination Hexagon

**HA3D1\_REF**

---







Destination Ellipse

**HASD1\_REF**

---

## Wire Arrows - Reference Only

---

Symbol	Description
 <b>HA1X1</b>	Generic Arrow - Left
 <b>HA1X2</b>	Generic Arrow - Up
 <b>HA1X3</b>	Generic Arrow - Right
 <b>HA1X4</b>	Generic Arrow - Down
 <b>HA1X1Y</b>	Arrow Tail - Left

---



Arrow Tail - Up

HA1X2Y



Arrow Tail - Right

HA1X3Y





Arrow Tail - Down

HA1X4Y

## One-Line Components

### Connector

Horizontal Symbol	Vertical Symbol	Description
		Jack/Plug
HC01PJ_1-	VC01PJ_1-	

### Motor Control

Horizontal Symbol	Vertical Symbol	Description
-------------------	-----------------	-------------



HCB11\_1-

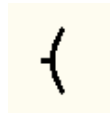

VCB11\_1-

Circuit breaker

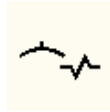

HCB11M\_1-



VCB11M\_1-

Motor circuit protector

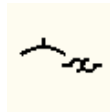

HCB11TH\_1-



VCB11TH\_1-

Thermal circuit breaker



HDS11\_1-

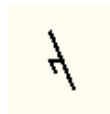

VDS11\_1-

Disconnect



HDS11F\_1-



VDS11F\_1-

Fused disconnect







HFU1\_1-



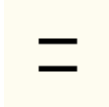
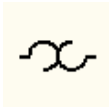
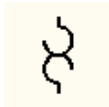

VFU1\_1-

Fuse

		Motor
HMO13_1-	VMO13_1-	
		Motor starter
HMS11_1-	VMS11_1-	
		Overload
HOL1_1-	VOL1_1-	
		Capacitor
	VCA113_1-	

## Transformer

Horizontal Symbol	Vertical Symbol	Description
		Transformer 1
HXF1_1-	VXF1_1-	

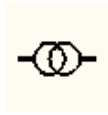

HXF2\_1-



VXF2\_1-

Transformer 2





## Terminal

Horizontal Symbol	Vertical Symbol	Description
		Square terminal
HT0001_1-	VT0001_1-	
		Round terminal
HT0002_1-	VT0002_1-	



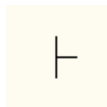

## Cable Marker

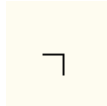
Horizontal Symbol	Vertical Symbol	Description
		Cable marker
HW01_1-	VW01_1-	

## Bus-tap

Horizontal Symbol	Vertical Symbol	Description
		Bus-tap - main/dot
<b>HDM1_BT_1-</b>	<b>VDV1_BT_1-</b>	
		Bus-tap - dual/tee
<b>HDM1_BT_1-</b>	<b>VDV1_BT_1-</b>	
		Bus-tap - dual/corner
<b>HDM1_BT_1-</b>	<b>VDV1_BT_1-</b>	

## Miscellaneous

Horizontal Symbol	Vertical Symbol	Description
		Power receptacle
<b>HCOMR_1-</b>	<b>VCOMR_1-</b>	
		Generic load
<b>HDM1_1-</b>	<b>VDV1_1-</b>	









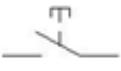

# IEC Symbols

# 7

## Push Buttons

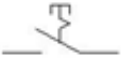
### Push Buttons

Horizontal Symbol	Vertical Symbol	Description
 HPB11	 VPB11	Push Button Normally Open
 HPB12	 VPB12	Push Button Normally Closed
 HPB11L	 VPB11L	Push Button Normally Open Latching

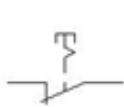

**HPB12L**



**VPB12L**

Push Button Normally Closed Latching



**HPB11M**

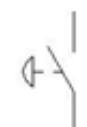

**VPB11M**

Mushroom Head Normally Open



**HPB12M**

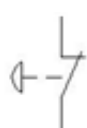

**VPB12M**

Mushroom Head Normally Closed



**HPB11ML**



**VPB11ML**

Mushroom Head Normally Open Latching



**HPB12ML**



**VPB12ML**

Mushroom Head Normally Closed Latching



**HPB11MTL**



**VPB11MTL**

Mushroom Head Normally Open Twist Latch



**HPB12MTL**



**VPB12MTL**

Mushroom Head Normally Closed Twist Latch



**HPB11S80**



**VPB11S80**

Mushroom Head Normally Open Latching, Pull to Disengage



**HPB12S80**



**VPB12S80**

Mushroom Head Normally Closed Latching, Pull to Disengage



**HPB11S82**



**VPB11S82**

Mushroom Head Normally Open Latching, Key Operated



**HPB12S82**



**VPB12S82**

Mushroom Head Normally Closed Latching, Key Operated



**HPB11RE**



**VPB11RE**

Normally Open Push Button Recessed



**HPB12RE**

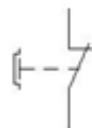

**VPB12RE**

Normally Closed Push Button Recessed



**HPB11REL**



**VPB11REL**

Normally Open Push Button Recessed Latched



**HPB12REL**



**VPB12REL**

Normally Closed Push Button Recessed Latched



**HPB11PM**



**VPB11PM**

Normally Open Push Button Positive Make



**HPB12PB**



**VPB12PB**

Normally Closed Push Button Positive Break



**HPB21**





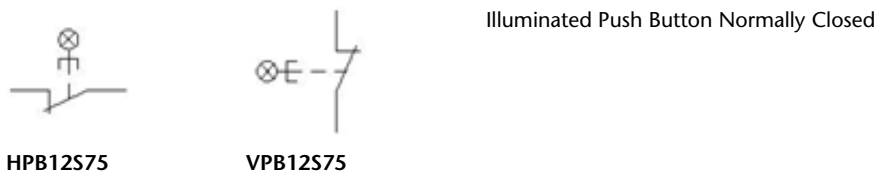
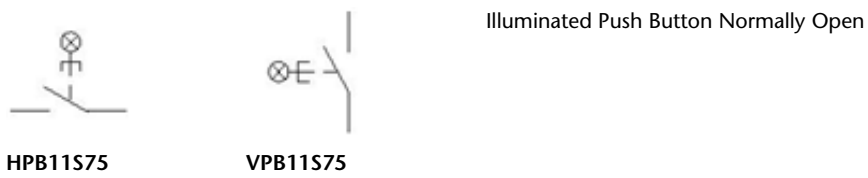

**VPB21**

2nd+ Normally Open Contact

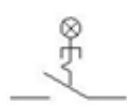







## Illuminated Push Buttons

Horizontal Symbol	Vertical Symbol	Description
		Non-Auto Return Illuminated Push Button Normally Open
<b>HPB11S76</b>	<b>VPB11S76</b>	
		Non-Auto return Illuminated Push Button Normally Closed
<b>HPB12S76</b>	<b>VPB12S76</b>	

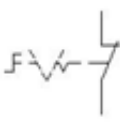
# Selector Switches

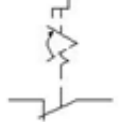
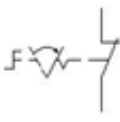
## Selector Switches

Horizontal Symbol	Vertical Symbol	Description
		2 Position Maintain, Normally Open
<b>HSS112</b>	<b>VSS112</b>	
		2 Position Maintain, Normally Closed
<b>HSS122</b>	<b>VSS122</b>	
		2 Position Normally Open Return From Left
<b>HSS112L</b>	<b>VSS112L</b>	
		2 Position Normally Closed Return From Left
<b>HSS122L</b>	<b>VSS122L</b>	
		2 Position Normally Open Return From Right
<b>HSS112R</b>	<b>VSS112R</b>	



**HSS122R**

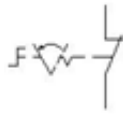

**VSS122R**

2 Position Normally Closed Return From Right



**HSW11S77**

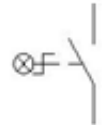

**VSW11S77**

2 Position Normally Open with Lamp



**HSW12S77**



**VSW12S77**

2 Position Normally Closed with Lamp

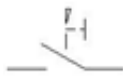

**HSS2121F**



**VSS2121F**

Normally Open Contact with Manual Unlatching

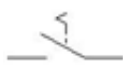

**HSS2122F**



**VSS2122F**

Normally Open Contact with Maintained Position













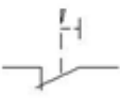

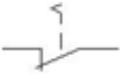
**HSS217F**



**VSS217F**



Normally Open Anticipated Contact

		Normally Open Delayed Contact
<b>HSS218F</b>	<b>VSS218F</b>	
		Normally Closed Contact with Manual Unlatching
<b>HSS2221F</b>	<b>VSS2221F</b>	
		Normally Closed Contact with Maintained Position
<b>HSS2222F</b>	<b>VSS2222F</b>	
		Normally Closed Anticipated Contact
<b>HSS227F</b>	<b>VSS227F</b>	
		Normally Closed Delayed Contact
<b>HSS228F</b>	<b>VSS228F</b>	
		Non-Latched, Normally Open
<b>HSS11NL</b>	<b>VSS11NL</b>	

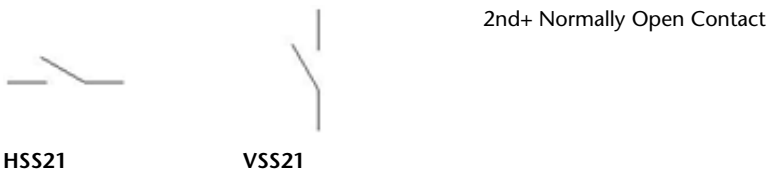
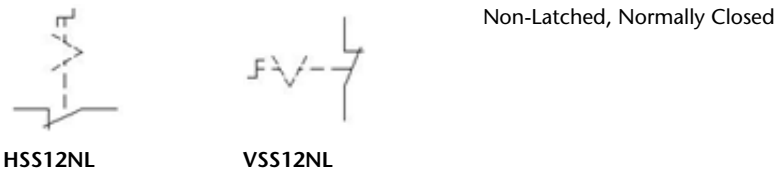

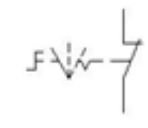

### 3 Position Selector Switches

Horizontal Symbol	Vertical Symbol	Description
		3 Position Maintain, Normally Open
<b>HSS113</b>	<b>VSS113</b>	
		3 Position Maintain, Normally Closed
<b>HSS123</b>	<b>VSS123</b>	



**HSS113L**



**VSS113L**

3 Position Normally Open Return From Left



**HSS123L**

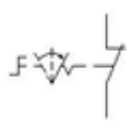

**VSS123L**

3 Position Normally Closed Return From Left



**HSS113R**



**VSS113R**

3 Position Normally Open Return From Right



**HSS123R**

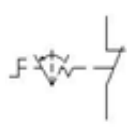

**VSS123R**

3 Position Normally Closed Return From Right

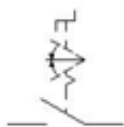

**HSS113B**

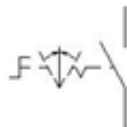

**VSS113B**

3 Position Normally Open Return From Both



**HSS123B**

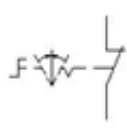

**VSS123B**

3 Position Normally Closed Return From Both



HSS11S31



VSS11S31

3 Position Normally Open Neutral 0



HSS12S31

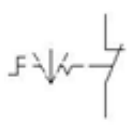

VSS12S31

3 Position Normally Closed Neutral 0



HSS11S32



HSS11S32

3 Position Normally Open Neutral 1



HSS12S32



HSS12S32

3 Position Normally Closed Neutral 1



HSS11S33



HSS11S33

3 Position Normally Open Neutral 2



HSS12S33



HSS12S33

3 Position Normally Closed Neutral 2



HSS11S40



HSS11S40

3 Position Normally Open Key Operated Neutral 0



HSS12S40



HSS12S40

3 Position Normally Closed Key Operated Neutral 0



HSS11S41



HSS11S41

3 Position Normally Open Key Operated Neutral 1



HSS12S41



HSS12S41

3 Position Normally Closed Key Operated Neutral 1



HSS11S42



HSS11S42

3 Position Normally Open Key Operated Neutral 2



HSS12S42



HSS12S42

3 Position Normally Closed Key Operated Neutral 2



HSS11S43



HSS11S43

3 Stable Position Normally Open Key Operated  
Neutral 0



HSS12S43



HSS12S43

3 Stable Position Normally Closed Key Operated  
Neutral 0



HSS11S44



HSS11S44

3 Stable Position Normally Open Key Operated  
Neutral 1



HSS12S44



HSS12S44

3 Stable Position Normally Closed Key Operated  
Neutral 1



HSS11S45



HSS11S45

3 Stable Position Normally Open Key Operated  
Neutral 2













HSS12S45



HSS12S45

3 Stable Position Normally Closed Key Operated  
Neutral 2

## 4 Position Selector Switches

Horizontal Symbol	Vertical Symbol	Description
 <b>HSS114</b>	 <b>VSS114</b>	4 Position Maintain, Normally Open
 <b>HSS124</b>	 <b>VSS124</b>	4 Position Maintain, Normally Closed
 <b>HSS11S46</b>	 <b>VSS11S46</b>	4 Position Key Selector Normally Open
 <b>HSS12S46</b>	 <b>VSS12S46</b>	4 Position Key Selector Normally Closed
 <b>HSS11S49</b>	 <b>VSS11S49</b>	4 Stable Positions Key Selector Normally Open



**HSS12S49**



**VSS12S49**

4 Stable Positions Key Selector Normally Closed



**HSS11S50**



**VSS11S50**

4 Stable Positions Key Selector Normally Open-Rotating in 2 Ways



**HSS12S50**



**VSS12S50**

4 Stable Positions Key Selector Normally Closed-Rotating in 2 Ways



**HSS11S51**



**VSS11S51**

4 Stable Positions Key Selector Normally Open-Rotating CW



**HSS12S51**











**VSS12S51**

4 Stable Positions Key Selector Normally Closed-Rotating CW

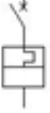
# Breakers, Disconnects

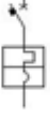
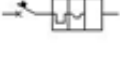
## 1 Pole Circuit Breakers

Horizontal Symbol	Vertical Symbol	Description
		Circuit Breaker 1 Pole
<b>HCB1</b>	<b>VCB1</b>	
		Thermal Circuit Breaker
<b>HCB11TH</b>	<b>VCB11TH</b>	
		Current Limit/Thermal
<b>HCB11THI</b>	<b>VCB11THI</b>	
		Magneto/Thermal
<b>HCB11Q9</b>	<b>VCB11Q9</b>	
		Magneto/Thermal with Differential
<b>HCB11Q13</b>	<b>VCB11Q13</b>	



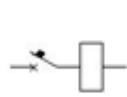

**HCB11Q17**



**VCB11Q17**

Differential

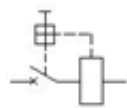

**HCB11Q29**

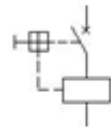

**VCB11Q29**

With Current Protection

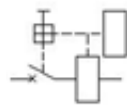

**HCB11Q33**

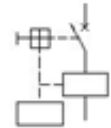

**VCB11Q33**

With Current Protection and Lack of Voltage Protection

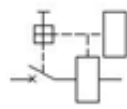

**HCB11Q37**

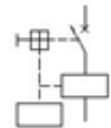

**VCB11Q37**

With Max. Current and Min. Voltage Protection

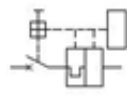

**HCB11Q41**

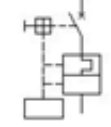

**VCB11Q41**

With Max. Thermal/Current and Min. Voltage Protection

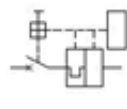

**HCB11Q45**

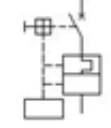





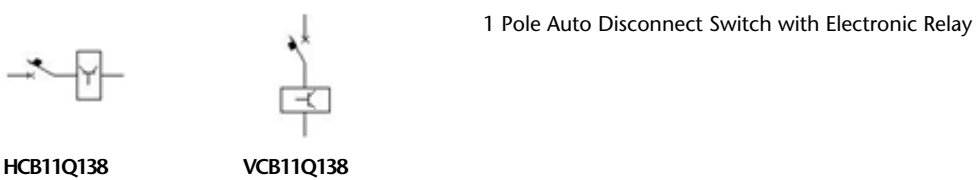
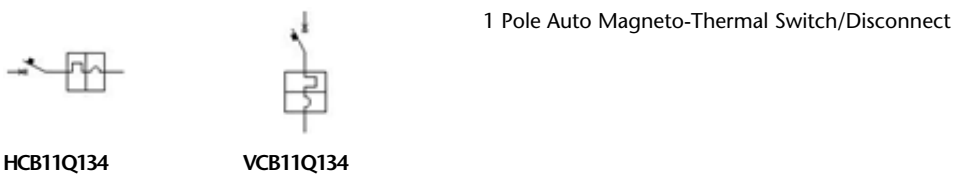
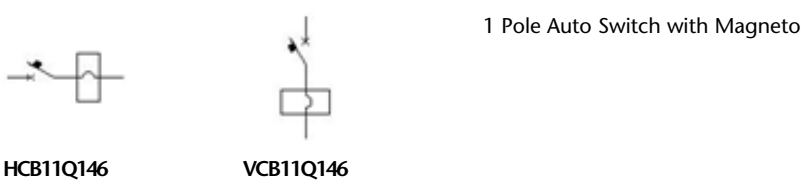
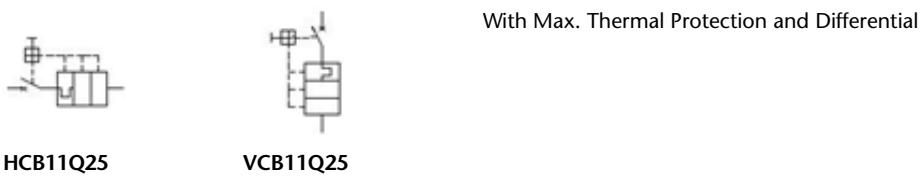
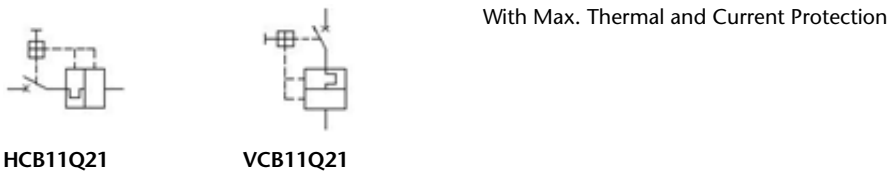







**VCB11Q45**

With Max. Thermal and Min. Voltage Protection



## 2nd+ Pole Circuit Breakers

Horizontal Symbol	Vertical Symbol	Description
-------------------	-----------------	-------------

		Circuit Breaker 2nd+ Pole
<b>HCB2</b>	<b>VCB2</b>	
		Thermal 2nd+ Pole
<b>HCB21TH</b>	<b>VCB21TH</b>	
		Current Limit/Thermal 2nd+ Pole
<b>HCB21THI</b>	<b>VCB21THI</b>	
		Disconnect 2nd+ Pole
<b>HDS21</b>	<b>VDS21</b>	
		Disconnect Normally Open Auxiliary Contact
<b>HDS21AUX</b>	<b>VDS21AUX</b>	
		Disconnect Normally Closed Auxiliary Contact
<b>HDS22AUX</b>	<b>VDS22AUX</b>	



**HCB2120F**



**VCB2120F**

Auto Return

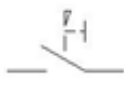

**HCB2121F**



**VCB2121F**

With Mechanical Block and Manual Unlatching

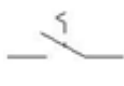

**HCB2122F**



**VCB2122F**

With Maintained Position

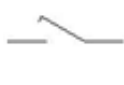

**HCB217F**



**VCB217F**

Anticipated Contact

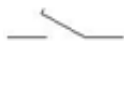

**HCB218F**



**VCB218F**

Delayed Contact

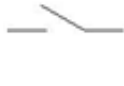

**HCB21**



**VCB21**

Circuit Breaker Normally Open Auxiliary Contact

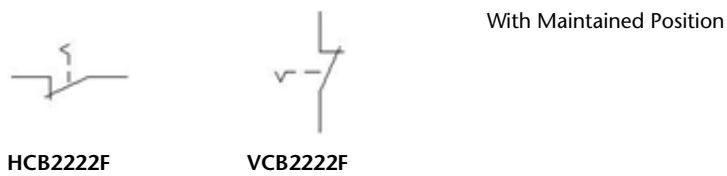
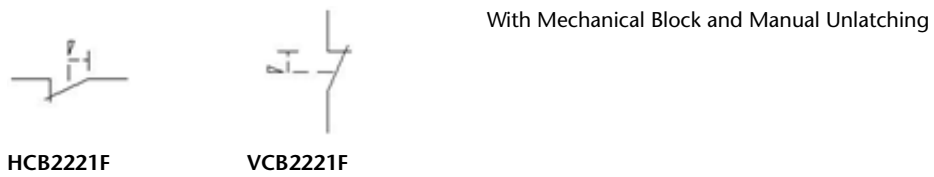
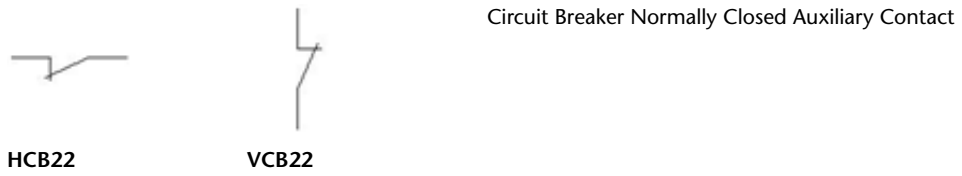

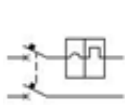

HCB1Q142

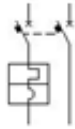

VCB1Q142

2 P Magneto-Thermal Switch, 1P Protected

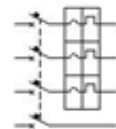

HCB1Q143

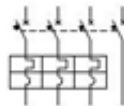

VCB1Q143

4 P Magneto-Thermal Switch, 3P Protected

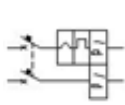

HCB1Q144

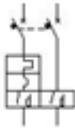

VCB1Q144

2 P Magneto-Thermal Switch with Differential, 1P Protected

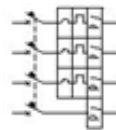

HCB1Q145

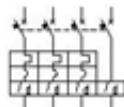

VCB1Q145

4 P Magneto-Thermal Switch with Differential, 3P Protected

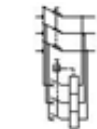

HDS1Q93

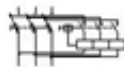



VDS1Q93

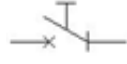
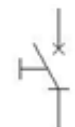

3 P 2 Way Disconnect Switch with Fuses

## Power Switches

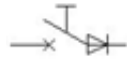

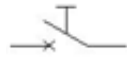

Horizontal Symbol	Vertical Symbol	Description
-------------------	-----------------	-------------





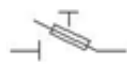

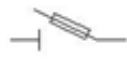





		1P with Semiconductors
<b>HCB11Q53</b>	<b>VCB11Q53</b>	

		1P with Semiconductors - unidirectional
<b>HCB11Q57</b>	<b>VCB11Q57</b>	

		2P Power Switch
<b>HCB11Q50</b>	<b>VCB11Q50</b>	







## Fusible Disconnects

Horizontal Symbol	Vertical Symbol	Description
		Fused switch
<b>HDS11F</b>	<b>VDS11F</b>	
		2nd+ Pole Fused Switch
<b>HDS21F</b>	<b>VDS21F</b>	

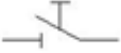
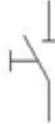

		Auxiliary Contact, Normally Open
<b>HDS21AUX</b>	<b>VDS21AUX</b>	
		Auxiliary Contact, Normally Closed
<b>HDS22AUX</b>	<b>VDS22AUX</b>	
		1 Pole on load
<b>HDS1OL</b>	<b>VDS1OL</b>	
		2nd+ Pole on load
<b>HDS2OL</b>	<b>VDS2OL</b>	
		1 Phase Disconnect with Fuse
<b>HDS11Q81</b>	<b>VDS11Q81</b>	
		1 Phase maneuver Switch/Disconnect with Fuse
<b>HDS11Q85</b>	<b>VDS11Q85</b>	

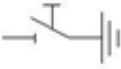
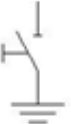

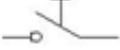
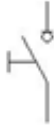

## Disconnect 1 Pole

Horizontal Symbol	Vertical Symbol	Description
		Disconnect 1 Pole
<b>HDS11Q65</b>	<b>VDS11Q65</b>	
		Disconnect 1 Pole Non-Fused
<b>HDS11</b>	<b>VDS11</b>	
		Maneuver Switch with Fuse
<b>HDS11Q119</b>	<b>VDS11Q119</b>	
		PE Earthing Switch
<b>HDS11Q123</b>	<b>VDS11Q123</b>	
		Power Auto Switch/Disconnect
<b>HDS11Q5</b>	<b>VDS11Q5</b>	

		Maneuver Switch/Disconnect
HDS11Q69	VDS11Q69	

		Disconnect with Lock Device
HDS11Q73	VDS11Q73	



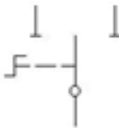





		Switch/Disconnect with Lock Device
HDS11Q77	VDS11Q77	

		Two Way Disconnect with 3 Positions
HDS11Q89	VDS11Q89	



## Fuses, Transformers, Reactors











### Reactors

Horizontal Symbol	Vertical Symbol	Description
-------------------	-----------------	-------------

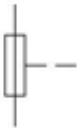



		Reactors - General
<b>HRT1</b>	<b>VRT1</b>	
		Reactors - Iron cored
<b>HRT1IC</b>	<b>VRT1IC</b>	
		Inductor With Magnetic Core Air Gap
<b>HRT1L3</b>	<b>VRT1L3</b>	
		Inductor With Magnetic Core Continuously Variable
<b>HRT1L4</b>	<b>VRT1L4</b>	

## Fuses



Horizontal Symbol	Vertical Symbol	Description
		Fuse
<b>HFU1</b>	<b>VFU1</b>	

		Fuse Auxiliary Contact, Normally Open
<b>HFU21</b>	<b>VFU21</b>	
		Fuse Auxiliary Contact, Normally Closed
<b>HFU22</b>	<b>VFU22</b>	
		Stiker
<b>HFU1ST</b>	<b>VFU1ST</b>	
		With alarm contact
<b>HFU1AC</b>	<b>VFU1AC</b>	
		With separate alarm contact
<b>HFU1LS</b>	<b>VFU1LS</b>	
		1 Pole - Live Side
<b>HFU2LS</b>	<b>VFU2LS</b>	

## Fuse Switches

Horizontal Symbol	Vertical Symbol	Description
		1 Pole
<b>HFU1FS</b>	<b>VFU1FS</b>	
		1 Pole Child
<b>HFU2FS</b>	<b>VFU2FS</b>	

## Transformers

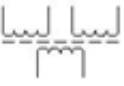
Horizontal Symbol	Vertical Symbol	Description
		Transformer
<b>HXF1</b>	<b>VXF1</b>	
		Transformer Dual
<b>HXF1D</b>	<b>VXF1D</b>	

		Transformer Dual (flipped)
<b>HXF1DR</b>	<b>VXF1DR</b>	
<hr/>		
		Potential Transformer
<b>HXF1PT</b>	<b>VXF1PT</b>	
<hr/>		
		Single phase auto
<b>HXF1P1AUTO</b>	<b>VXF1P1AUTO</b>	
<hr/>		
		1 Phase Autotransformer
<b>HXF1T18</b>	<b>VXF1T18</b>	
<hr/>		
		3 Phase Autotransformer Star Connected
<b>HXF1T19</b>	<b>VXF1T19</b>	
<hr/>		
		Power Transformer 1 with 2 Windings
<b>HXF1T2</b>	<b>VXF1T2</b>	
<hr/>		

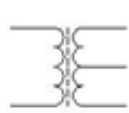

HXF1T4

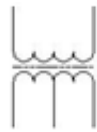

VXF1T4

Power Transformer 2 with 2 Windings

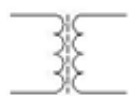

HXF1T3



VXF1T3

Power Transformer with 2 Windings and Screen

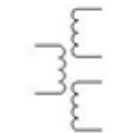

HXF1T6

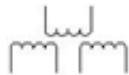

VXF1T6

Power Transformer with 3 Windings

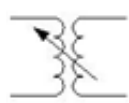

HXF1T5



VXF1T5

Adjustable Power Transformer with 2 Windings



HXF1T34



VXF1T34

Voltage Transformer

## Current Transformers

Horizontal Symbol	Vertical Symbol	Description
-------------------	-----------------	-------------



**HXF1CT**



**VXF1CT**

CT Current Transformer



**HXF1CTR**



**VXF1CTR**

CT (Flipped)



**HXF1T1**

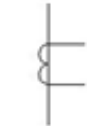

**VXF1T1**

Current Transformer 2



**HXF1T30**



**VXF1T30**

With 2 Secondaries - Independent Magnetic Circuits



**HXF1T31**



**VXF1T31**

With 2 Secondaries - Common Magnetic Circuit



**HXF1T32**



**VXF1T32**

With Tapped Secondary Winding





HXF1T33



VXF1T33

With Conductor Indication

### 3 Phase Transformers

Horizontal Symbol	Vertical Symbol	Description
		3 Phase
		3 Phase Star/Delta
		3 Phase Star/Delta Primary with Sockets
		3 Phase Star/Zigzag



**HXF1T13**

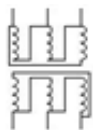

**VXF1T13**

3 Phase Delta/Delta



**HXF1T14**

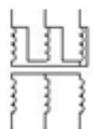

**VXF1T14**

3 Phase Delta/Star



**HXF1T15**

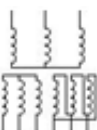

**VXF1T15**

3 Phase Star/Star/Delta with 3 Windings



**HXF1T20**



**VXF1T20**

3 Phase Delta/Delta



**HXF1T7**

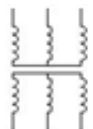

**VXF1T7**

3 Phase Star/Star

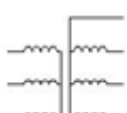

**HXF1T8**



**VXF1T8**

3 Phase Star/Star Secondary with Neutral



**HXF1T9**



**VXF1T9**

3 Phase Star/Star Primary with Plugs



**HXF1T21**



**VXF1T21**

3 Phase Dy5



**HXF1T22**



**VXF1T22**

3 Phase Dd6



**HXF1T23**

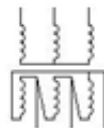

**VXF1T23**

3 Phase Yd5



**HXF1T24**

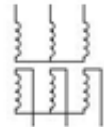

**VXF1T24**

3 Phase Yy6



**HXF1T25**







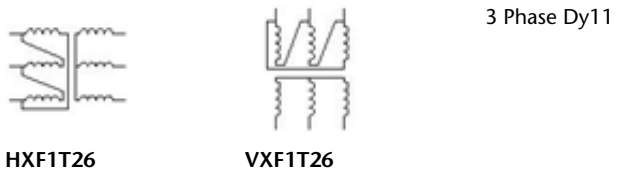



**VXF1T25**

3 Phase Yd11

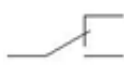

# Relays, Contacts

## Relays and Contacts

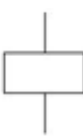
Horizontal Symbol	Vertical Symbol	Description
 HCR21	 VCR21	Relay Normally Open Contact
 HCR22	 VCR22	Relay Normally Closed Contact
 HCR23R	 VCR23R	Relay Form C
 HCR23	 VCR23	Relay Form C Flipped
 HCR1	 VCR1	Relay Coil

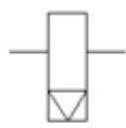

**HLR1**

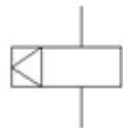

**VLR1**

Latch Relay Coil

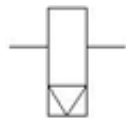

**HLR2**

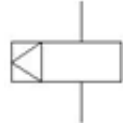

**VLR2**

Latch relay (child coil)



**HCR1SSD**

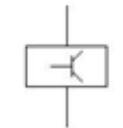

**VCR1SSD**

Solid State

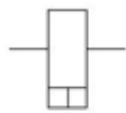

**HCR1HSP**

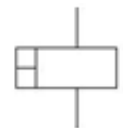

**VCR1HSP**

High Speed



**HCR1ACU**

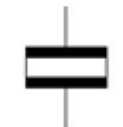

**VCR1ACU**

AC Unaffected

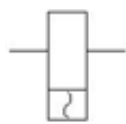

**HCR1AC**

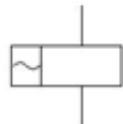

**VCR1AC**

AC

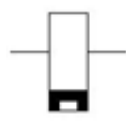

HCR1POL

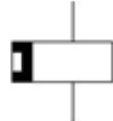

VCR1POL

Polarized



HCR1MSR



VCR1MSR

Measuring



HCR2121F



VCR2121F

With Mechanical Block and Manual Unlatching

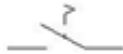

HCR2122F



VCR2122F

With Maintained Position



HCR217F



VCR217F

Anticipated Contact



HCR218F



VCR218F

Delayed Contact

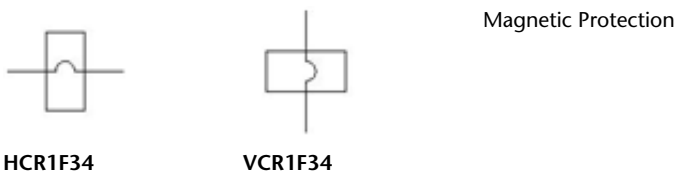
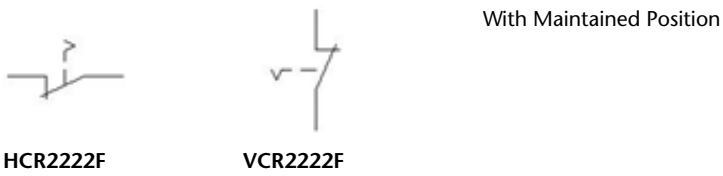
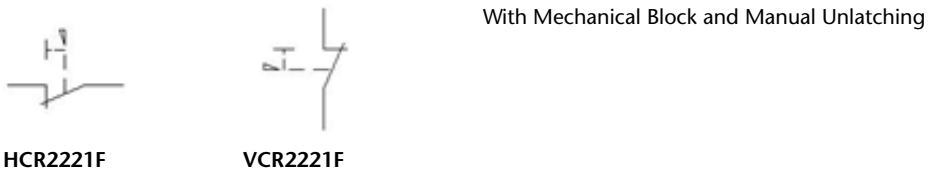

## Relays with Suppression

Horizontal Symbol	Vertical Symbol	Description
-------------------	-----------------	-------------





HCR1K33



VCR1K33

Relay with Integrated Block Diode



HCR1K35



VCR1K35

Relay with Integrated Block Diode and Integrated LED

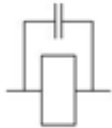

HCR1K37

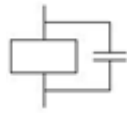

VCR1K37

Relay with Capacitor

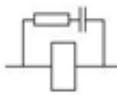

HCR1K39

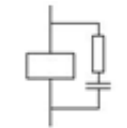

VCR1K39

Relay with RC Circuit

## Current Protection Relays

Horizontal Symbol

Vertical Symbol

Description

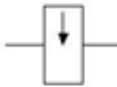

HCR1F28

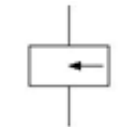

VCR1F28

Come Back Current Protection

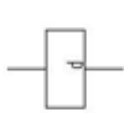

**HCR1F29**

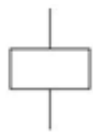

**VCR1F29**

Differential Current Protection



**HCR1F30**

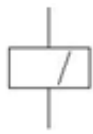

**VCR1F30**

Differential Current Protection - Relative Value



**HCR1F25**

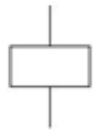

**VCR1F25**

Maximum Current Protection



**HCR1F26**

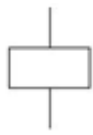

**VCR1F26**

Minimum Current Protection



**HCR1F27**

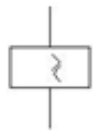

**VCR1F27**

Minimum and Maximum Current Protection

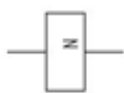

**HCR1F32**

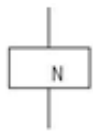





**VCR1F32**

In Neutral

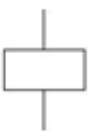

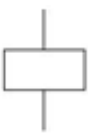
## Voltage Protection Relays

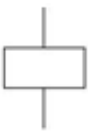

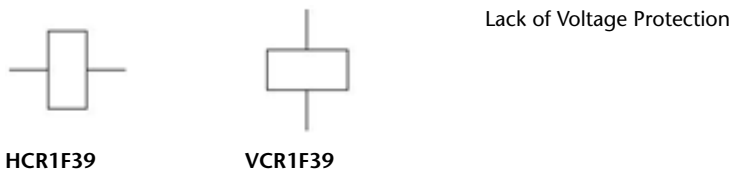



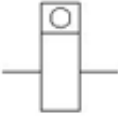
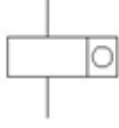
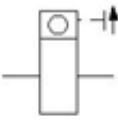
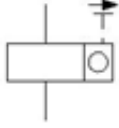
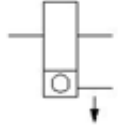
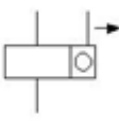

Horizontal Symbol	Vertical Symbol	Description
		Minimum Voltage Protection
<b>HCR1F35</b>	<b>VCR1F35</b>	
		Maximum Voltage Protection
<b>HCR1F36</b>	<b>VCR1F36</b>	
		Residual Voltage Protection
<b>HCR1F38</b>	<b>VCR1F38</b>	

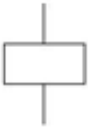

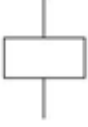
## Counter Relays

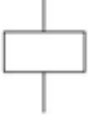

Horizontal Symbol	Vertical Symbol	Description
		Counter No Reset
<b>HCR1CNN</b>	<b>VCR1CNN</b>	
		Counter Manual Reset
<b>HCR1CNM</b>	<b>VCR1CNM</b>	
		Counter Electronic Reset
<b>HCR1CNE</b>	<b>VCR1CNE</b>	

## Miscellaneous Relays

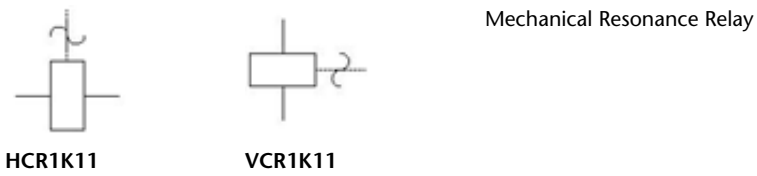
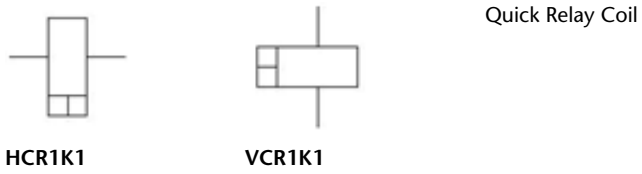
Horizontal Symbol	Vertical Symbol	Description
		Frequency Relay
<b>HCR1F40</b>	<b>VCR1F40</b>	
		Minimum Impedance Relay
<b>HCR1F41</b>	<b>VCR1F41</b>	
		Relay Sensing Lack of Phase in Three Phase System
<b>HCR1F42</b>	<b>VCR1F42</b>	
		Minimum Active Power Relay
<b>HCR1F43</b>	<b>VCR1F43</b>	
		Insulating Relay
<b>HCR1F44</b>	<b>VCR1F44</b>	

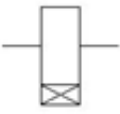
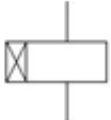
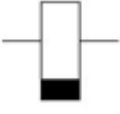
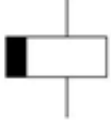
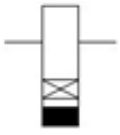

## Time Delay Relays

Horizontal Symbol	Vertical Symbol	Description
		ON Delay Coil
<b>HTD1N</b>	<b>VTD1N</b>	
		OFF Delay Coil
<b>HTD1F</b>	<b>VTD1F</b>	
		ON/OFF Delay
<b>HCR1OOD</b>	<b>VCR1OOD</b>	

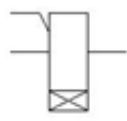

HTD1K25

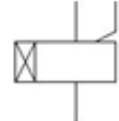

VTD1K25

3 Clamp Delay Relay - Energized

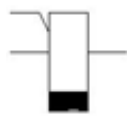

HTD1K27

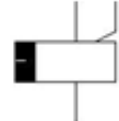

VTD1K27

3 Clamp Delay Relay - De-energized

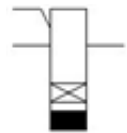

HTD1K29

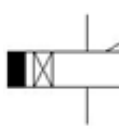

VTD1K29

3 Clamp Delay Relay - Energized/De-energized

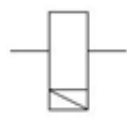

HTD1K5

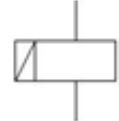

VTD1K5

Latency Relay



HTD21N



VTD21N

ON Delay Normally Open(Delay Close)



HTD22N



VTD22N

ON Delay Normally Closed(Delay Open)

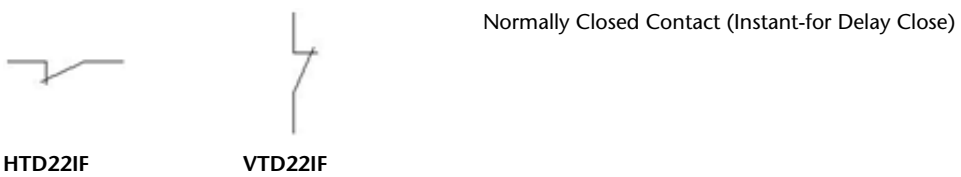
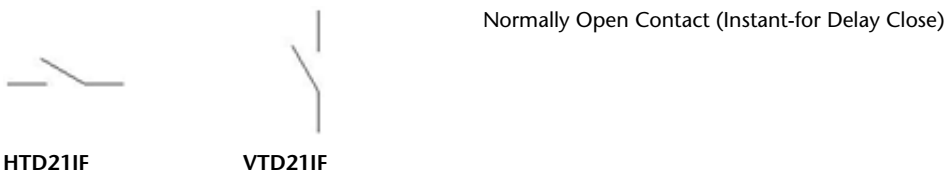
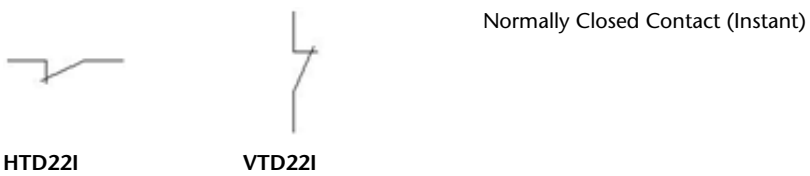
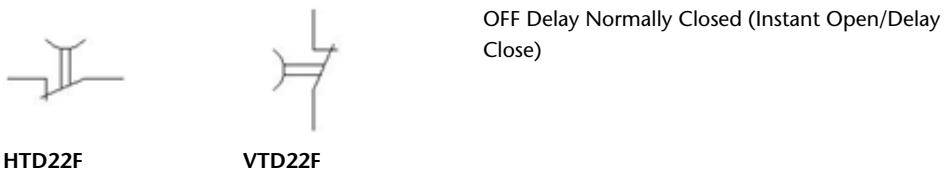



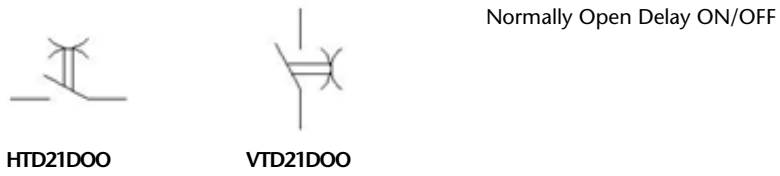

## Motor Control

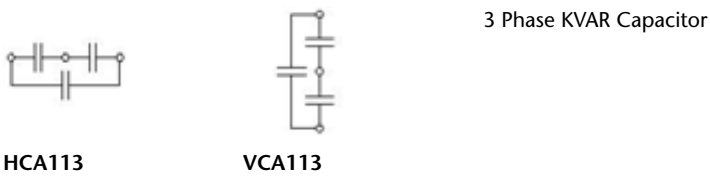
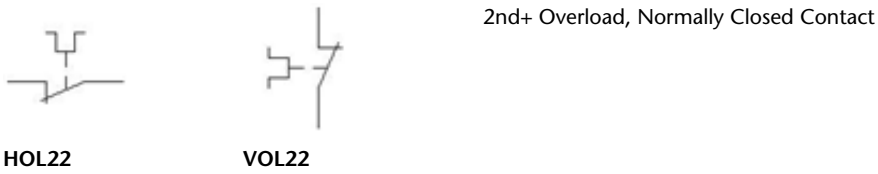
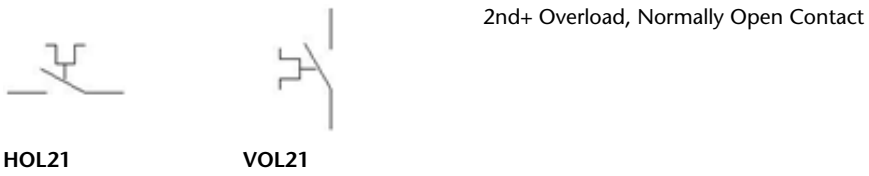

### Motor Control

Horizontal Symbol	Vertical Symbol	Description
		Overload, 1 Pole
<b>HOL1</b>	<b>VOL1</b>	
		2nd+ Overload Pole
<b>HOL2</b>	<b>VOL2</b>	



**NOTE** Multi-pole devices are constructed using parent and child symbols to adhere to the underlying ladder spacing.

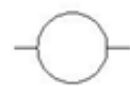



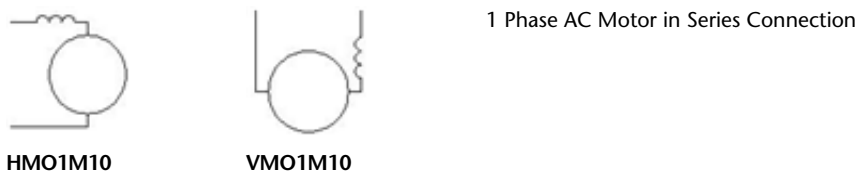

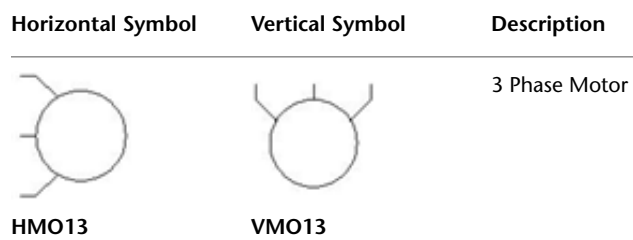

## 1 Phase Motors

Horizontal Symbol	Vertical Symbol	Description
		1 Phase Motor
<b>HMO12</b>	<b>VMO12</b>	

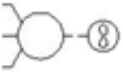

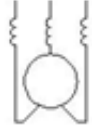
### 3 Phase Motors

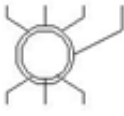

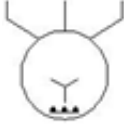
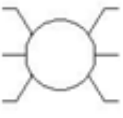
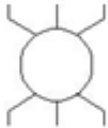
		3 Phase Motor (4 Connections)
<b>HMO14</b>	<b>VMO14</b>	
		3 Phase Motor with Fan
<b>HMO1M2</b>	<b>VMO1M2</b>	
		3 Phase Asyncho Motor with Series Excitation
<b>HMO1M3</b>	<b>VMO1M3</b>	
		3 Phase Asyncho Wound-Rotor Motor
<b>HMO1M4</b>	<b>VMO1M4</b>	
		3 Phase Asyncho Star Connected Stator Auto Starter on Rotor
<b>HMO1M5</b>	<b>VMO1M5</b>	
		3 Phase Asyncho Motor - 6 Pole
<b>HMO1M11</b>	<b>VMO1M11</b>	



HMO1M17



VMO1M17

3 Phase Synchronous AC Motor

## DC Motors

Horizontal Symbol

Vertical Symbol

Description



HMO1M6



VMO1M6

DC Motor



HMO1M13

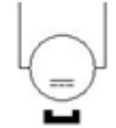

VMO1M13

DC Motor with Permanent Magnets



HMO1M14

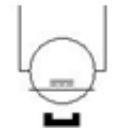

VMO1M14

DC Motor - Linear with Permanent Magnets



HMO1M15

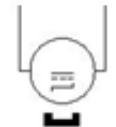

VMO1M15

DC Motor - Stepping with Permanent Magnets



HMO1M7



VMO1M7

DC Motor - Series Excitation

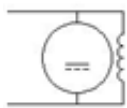

HMO1M8

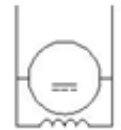

VMO1M8

DC Motor - Derived Excitation

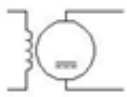

HMO1M12



VMO1M12

DC Motor - Independent Excitation

## Generators

Horizontal Symbol

Vertical Symbol

Description



HPW1G9

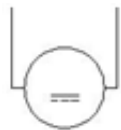

VPW1G9

DC Generator

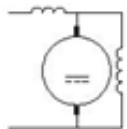

HPW1G10

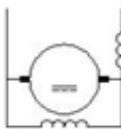

VPW1G10

DC Generator with Compound Excitation

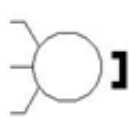

HPW1G6



VPW1G6

3 Phase Synchro Generator with Permanent Magnets



HPW1G7

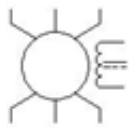

VPW1G7

3 Phase Synchro Generator 1





HPW1G8



VPW1G8

3 Phase Synchro Generator 2

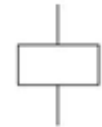
## Motor Starters

Horizontal Symbol	Vertical Symbol	Description
		Motor Starter Coil
		Motor Starter 1 Pole Normally Open (Power)

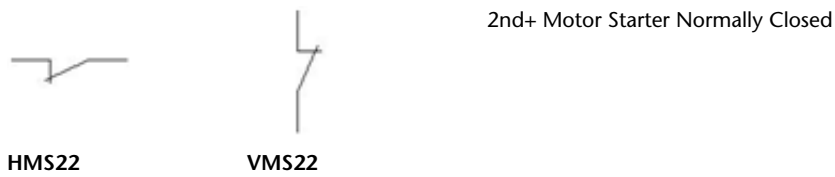
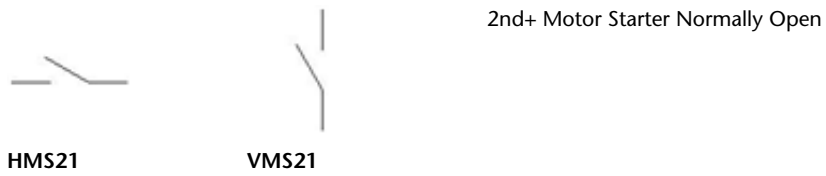
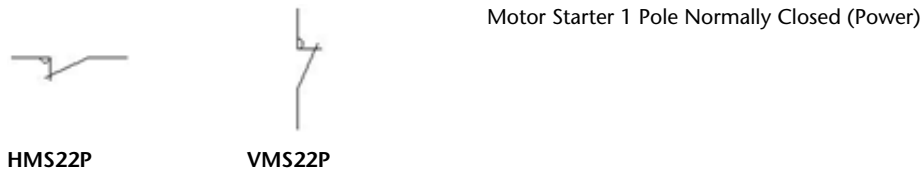

**NOTE** Multi-pole devices are constructed using parent and child symbols to adhere to the underlying ladder spacing.

## Pilot Lights

### Pilot Lights

Horizontal Symbol	Vertical Symbol	Description
		Blinking Device
HLT1H21	VLT1H21	



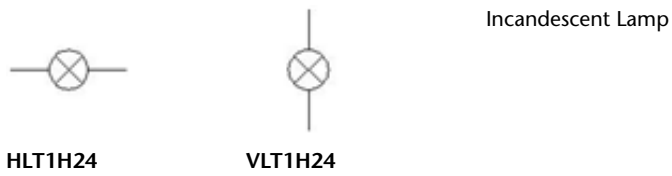

## Standard Lights



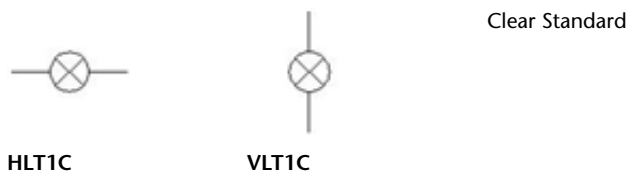
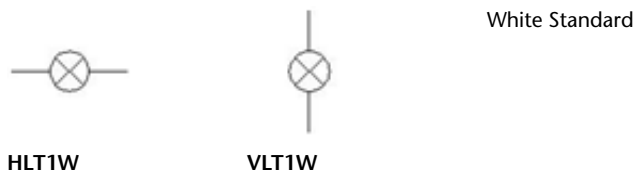
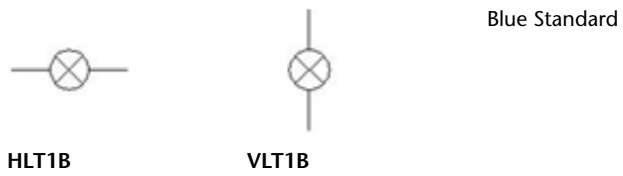







Horizontal Symbol	Vertical Symbol	Description
		Red Standard
HLT1R	VLT1R	
		Green Standard
HLT1G	VLT1G	
		Orange Standard
HLT1A	VLT1A	

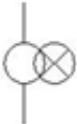

**NOTE** Lights receive text to indicate the color at the time of insertion.

## Transformer Lights

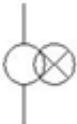

Horizontal Symbol	Vertical Symbol	Description
		Blinking Light - Bulb with Transformer
HLT1H10	VLT1H10	

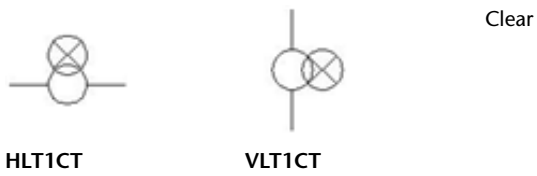
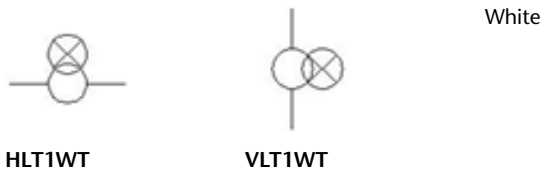
		Indicator Lamp Energized by Built-in Transformer
		
<b>HLT1H23A</b>	<b>VLT1H23A</b>	
<hr/>		
		Red
<b>HLT1RT</b>	<b>VLT1RT</b>	
<hr/>		
		Green
<b>HLT1GT</b>	<b>VLT1GT</b>	
<hr/>		
		Orange
<b>HLT1AT</b>	<b>VLT1AT</b>	
<hr/>		
		Yellow
<b>HLT1YT</b>	<b>VLT1YT</b>	
<hr/>		
		Blue
<b>HLT1BT</b>	<b>VLT1BT</b>	
<hr/>		

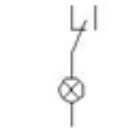
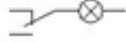
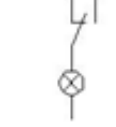
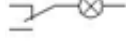

**NOTE** Lights receive text to indicate the color at the time of insertion.

## Push to Test Lights

Horizontal Symbol	Vertical Symbol	Description
		Red Press To Test
<b>HLT1RP</b>	<b>VLT1RP</b>	
		Green Press To Test
<b>HLT1GP</b>	<b>VLT1GP</b>	
		Orange Press To Test
<b>HLT1AP</b>	<b>VLT1AP</b>	

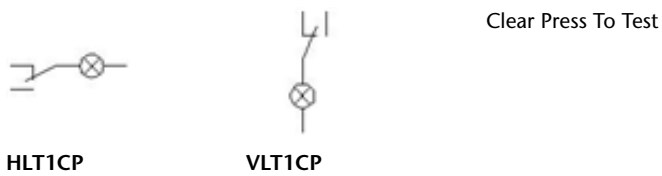
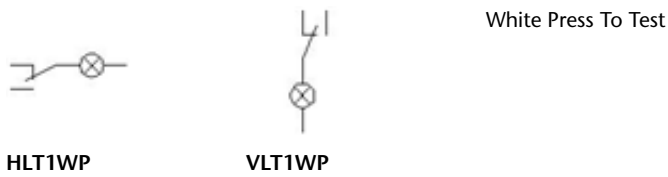
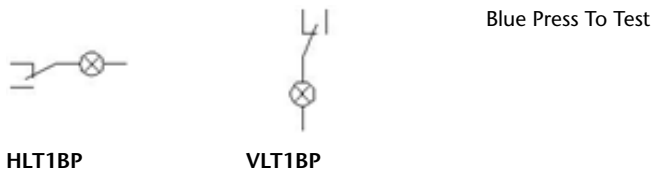
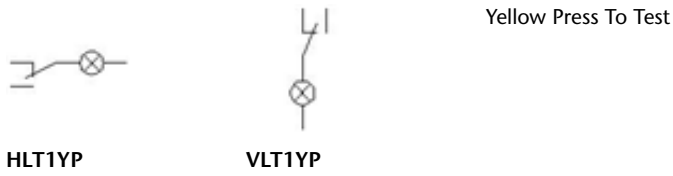

**NOTE** Lights receive text to indicate the color at the time of insertion.

## LEDs

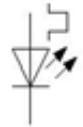
Horizontal Symbol	Vertical Symbol	Description
		Blinking LED
<b>HLT1H13</b>	<b>VLT1H13</b>	

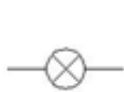

**HLT1H25**



**VLT1H25**

LED Indicator Lamp

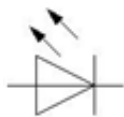

**HLT1RL**

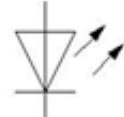

**VLT1RL**

Red

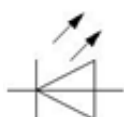

**HLT1RLR**



**VLT1RLR**

Red 180

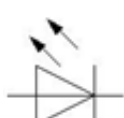

**HLT1GL**

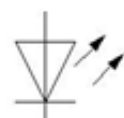

**VLT1GL**

Green

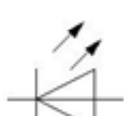

**HLT1GLR**



**VLT1GLR**

Green 180

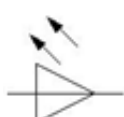

**HLT1AL**

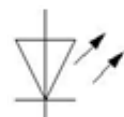

**VLT1AL**

Orange

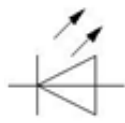

**HLT1ALR**



**VLT1ALR**

Orange 180

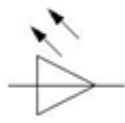

**HLT1YL**

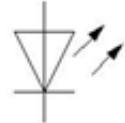

**VLT1YL**

Yellow

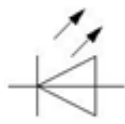

**HLT1YLR**



**VLT1YLR**

Yellow 180

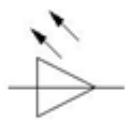

**HLT1BL**

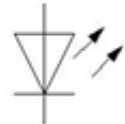

**VLT1BL**

Blue

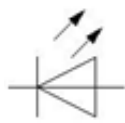

**HLT1BLR**



**VLT1BLR**

Blue 180

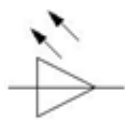

**HLT1WL**

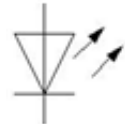

**VLT1WL**

White



HLT1WLR



VLT1WLR

White 180



HLT1CL

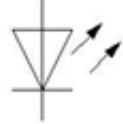

VLT1CL

Clear



HLT1CLR



VLT1CLR

Clear 180

**NOTE** Lights receive text to indicate the color at the time of insertion.

## Beacons - Flashing





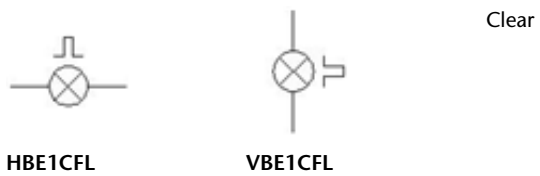
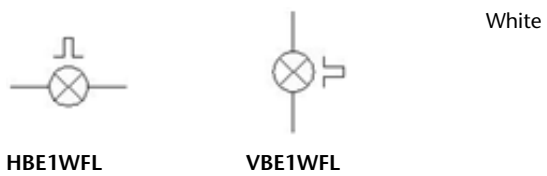
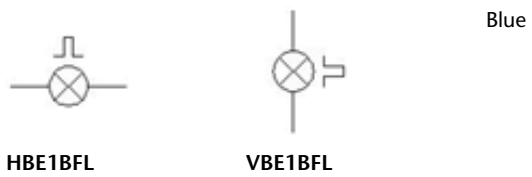
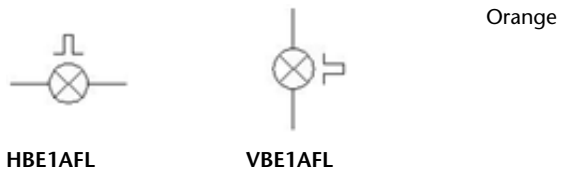





Horizontal Symbol	Vertical Symbol	Description
		Red
<p>HBE1RFL</p>	<p>VBE1RFL</p>	
		Green
<p>HBE1GFL</p>	<p>VBE1GFL</p>	





**NOTE** Lights receive text to indicate the color at the time of insertion.





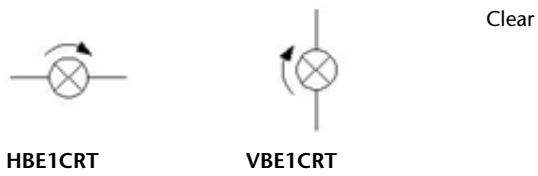
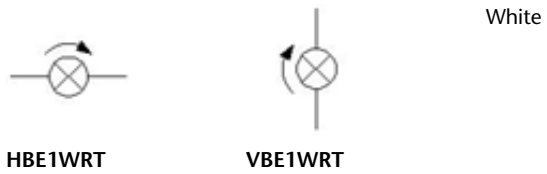

## Beacons - Rotating

Horizontal Symbol	Vertical Symbol	Description
		Red
<b>HBE1RRT</b>	<b>VBE1RRT</b>	
		Green
<b>HBE1GRT</b>	<b>VBE1GRT</b>	
		Orange
<b>HBE1ART</b>	<b>VBE1ART</b>	
		Yellow
<b>HBE1YRT</b>	<b>VBE1YRT</b>	
		Blue
<b>HBE1BRT</b>	<b>VBE1BRT</b>	



**NOTE** Lights receive text to indicate the color at the time of insertion.





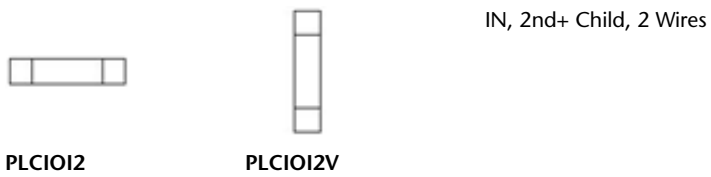





## PLC I/O

Horizontal Symbol	Vertical Symbol	Description
		IN, 1st Point, 1 Wire
PLCIO1T	PLCIO1TV	
		IN, 1st Point, 2 Wires
PLCIO2T	PLCIO2TV	
		OUT, 1st Point, 1 Wire
PLCIO01T	PLCIO01TV	



# Terminals, Connectors

## Terminals

Horizontal Symbol	Vertical Symbol	Description
 <b>HT0_01</b>	 <b>VT0_01</b>	Square
 <b>HT0W01</b>	 <b>VT0W01</b>	Square with Wire Number
 <b>HT0001</b>	 <b>VT0001</b>	Square with Terminal Number
 <b>HT1001</b>	 <b>VT1001</b>	Square with Wire Number Change
 <b>HT0_02</b>	 <b>VT0_02</b>	Round

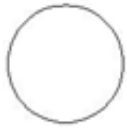

**HT0W02**

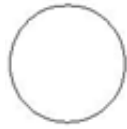

**VT0W02**

Round with Wire Number

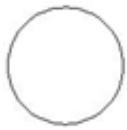

**HT0002**

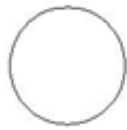

**VT0002**

Round with Terminal Number

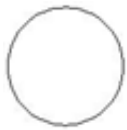

**HT1002**

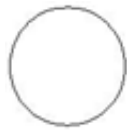

**VT1002**

Round with Wire Number Change



**HT0\_03**



**VT0\_03**

Hexagon



**HT0W03**



**VT0W03**

Hexagon with Wire Number



**HT0003**



**VT0003**

Hexagon with Terminal Number



**HT1003**



**VT1003**

Hexagon with Wire Number Change



**HT0\_04**



**VT0\_04**

Diamond



**HT0W04**



**VT0W04**

Diamond with Wire Number



**HT0004**



**VT0004**

Diamond with Terminal Number



**HT1004**



**VT1004**

Diamond with Wire Number Change



**HT0\_05**



**VT0\_05**

Triangle

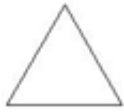

HT0W05

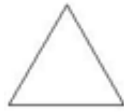

VT0W05

Triangle with Wire Number

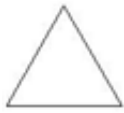

HT0005

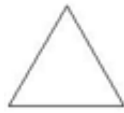

VT0005

Triangle with Terminal Number

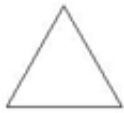

HT1005

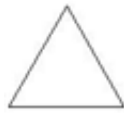

VT1005







Triangle with Wire Number Change

## In-Line Wire Labels



Horizontal Symbol	Vertical Symbol	Description
		In-Line Wire Label
HT0_LGEN- ERIC	VT0_LGEN- ERIC	
		Wire Number Copy
HT0.WGEN- ERIC	VT0.WGEN- ERIC	















## Power Distribution Blocks









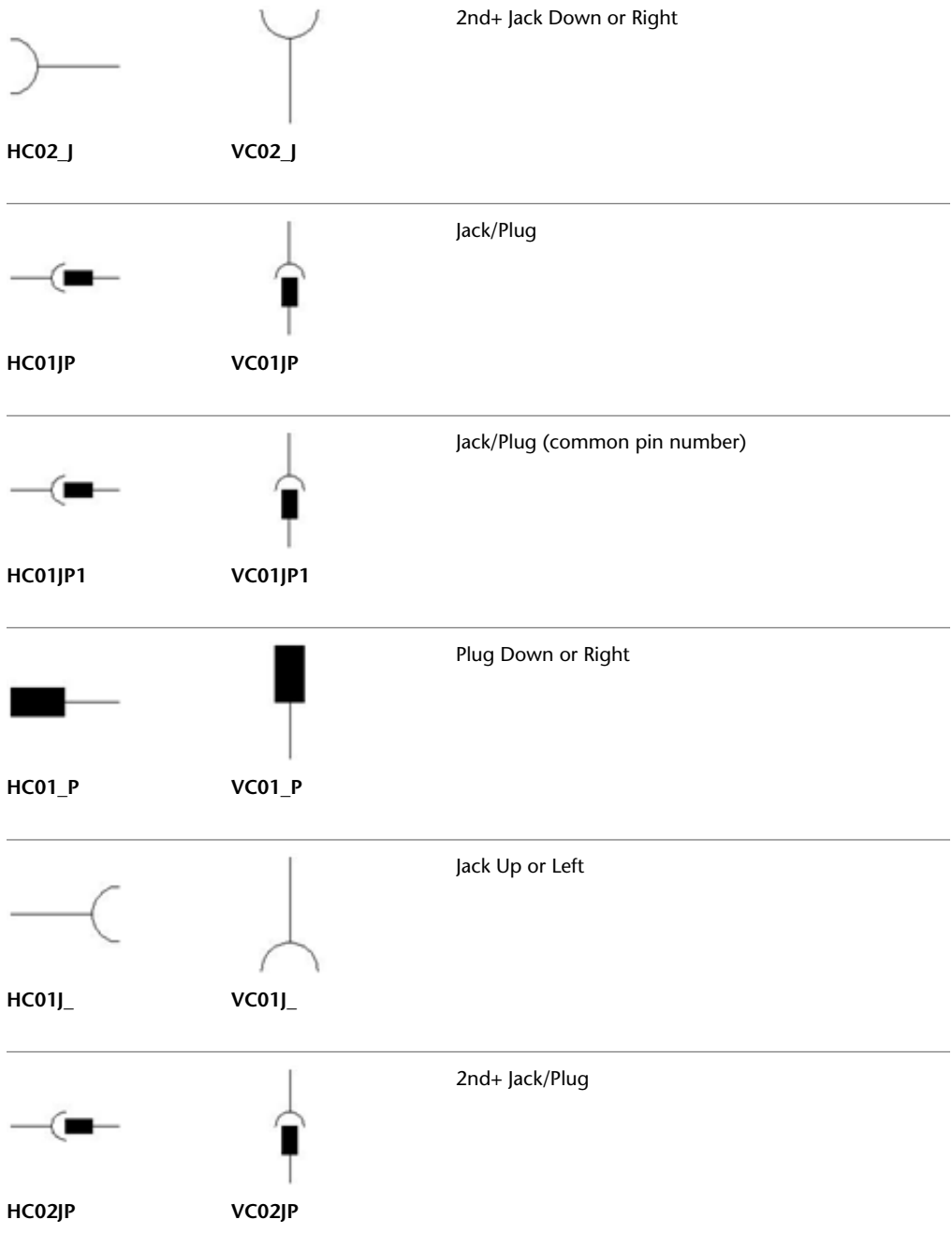



Horizontal Symbol	Vertical Symbol	Description
		3 Terminal, 10 Unit Spacing
<b>HDB1308</b>	<b>VDB1308</b>	
		3 Terminal, 15 Unit Spacing
<b>HDB1312</b>	<b>VDB1312</b>	
		3 Terminal, 20 Unit Spacing
<b>HDB1316</b>	<b>VDB1316</b>	











## Connectors - No Wirenumber Changes

Horizontal Symbol	Vertical Symbol	Description
		Plug/Jack
<b>HC01PJ</b>	<b>VC01PJ</b>	

		Plug/Jack (common pin number)
HC01PJ1	VC01PJ1	
		Plug Up or Left
HC01P_	VC01P_	
		Jack Down or Right
HC01_J	VC01_J	
		2nd+ Plug/Jack
HC02PJ	VC02PJ	
		2nd+ Plug/Jack (common pin number)
HC02PJ1	VC02PJ1	
		2nd+ Plug Up or Left
HC02P_	VC02P_	















		2nd+ Jack/Plug (common pin number)
HC02JP1	VC02JP1	
		2nd+ Plug Down or Right
HC02_P	VC02_P	
		2nd+ Jack Up or Left
HC02J_	VC02J_	
		Plug/Jack
HCN1PJ	VCN1PJ	
		Plug/Jack (common pin number)
HCN1PJ1	VCN1PJ1	
		Plug Up or Left
HC01P_	VC01P_	







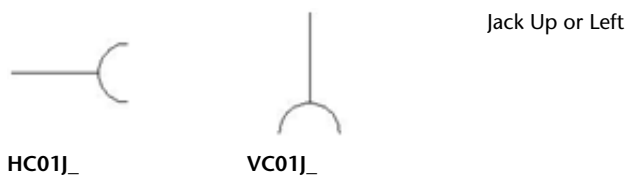
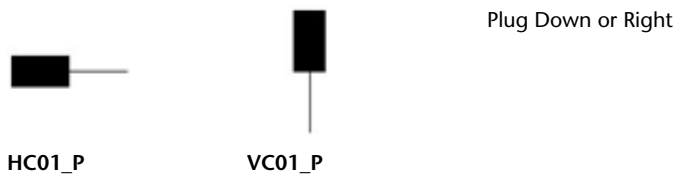
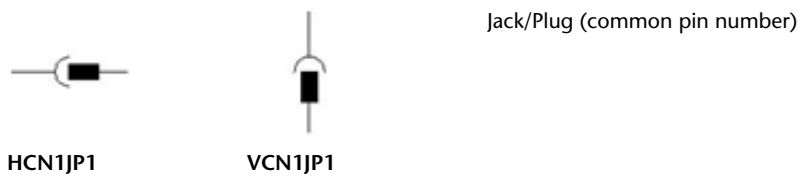
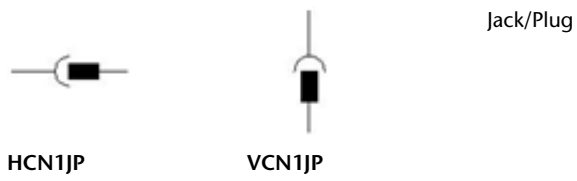
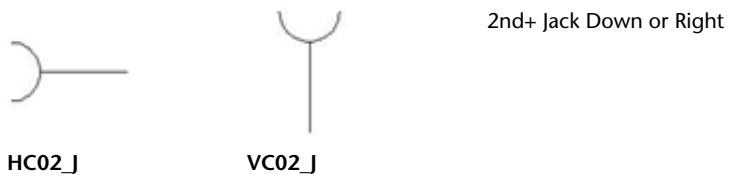
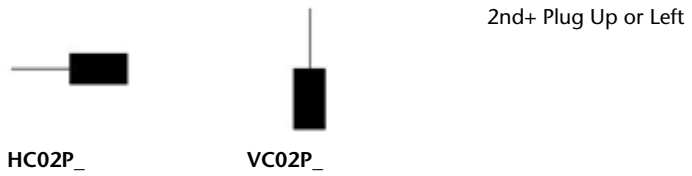

		Jack Down or Right
HC01_J	VC01_J	
		2nd+ Plug/Jack
HCN2PJ	VCN2PJ	
		2nd+ Plug/Jack (common pin number)
HCN2PJ1	VCN2PJ1	
		2nd+ Plug Up or Left
HC02P_	VC02P_	
		2nd+ Jack Down or Right
HC02_J	VC02_J	

## Connectors - Wirenumber Changes



Horizontal Symbol	Vertical Symbol	Description
-------------------	-----------------	-------------

		Plug/Jack
HCN1PJ	VCN1PJ	
		Plug/Jack (common pin number)
HCN1PJ1	VCN1PJ1	
		Plug Up or Left
HC01P_	VC01P_	
		Jack Down or Right
HC01_J	VC01_J	
		2nd+ Plug/Jack
HCN2PJ	VCN2PJ	
		2nd+ Plug/Jack (common pin number)
HCN2PJ1	VCN2PJ1	



		2nd+ Jack/Plug
HCN2JP	VCN2JP	
		2nd+ Jack/Plug (common pin number)
HCN2JP1	VCN2JP1	
		2nd+ Plug Down or Right
HC02_P	VC02_P	
		2nd+ Jack Up or Left
HC02_	VC02_	

## Limit Switches

Horizontal Symbol	Vertical Symbol	Description
		Limit Switch Normally Open
HLS11	VLS11	





**HLS12**



**VLS12**

Limit Switch Normally Closed

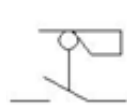

**HLS11C**



**VLS11C**

Limit Switch, Roller Normally Open

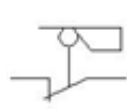

**HLS12C**



**VLS12C**

Limit Switch, Roller Normally Closed



**HLS11S13**



**VLS11S13**

Limit Switch Normally Open - Cam Driven



**HLS12S13**



**VLS12S13**

Limit Switch Normally Closed - Cam Driven

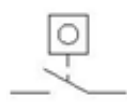

**HLS11S16**



**VLS11S16**

Limit Switch Normally Open - Events Driven



HLS12S16



VLS12S16

Limit Switch Normally Closed - Events Driven



HLS11S78



VLS11S78

2 Position Switch Normally Open with Detents and Lamp

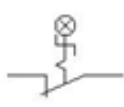

HLS12S78



VLS12S78

2 Position Switch Normally Closed with Detents and Lamp



HLS11S84

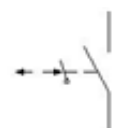

VLS11S84

Bi-directional Lever Actuated - Normally Open



HLS12S84

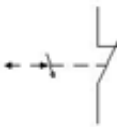

VLS12S84

Bi-directional Lever Actuated - Normally Closed

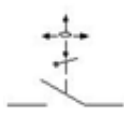

HLS11S85

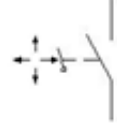

VLS11S85

Four-directional Lever Actuated - Normally Open



**HLS12S85**

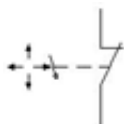

**VLS12S85**

Four-directional Lever Actuated - Normally Closed



**HLS11S87**

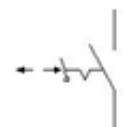

**VLS11S87**

Bi-directional Lever Actuated - Normally Open with Detent

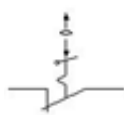

**HLS12S87**

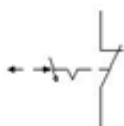

**VLS12S87**

Bi-directional Lever Actuated - Normally Closed with Detent



**HLS11S88**

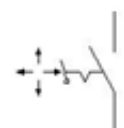

**VLS11S88**

Four-directional Lever Actuated - Normally Open with Detent

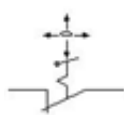

**HLS12S88**

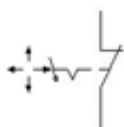

**VLS12S88**

Four-directional Lever Actuated - Normally Closed with Detent



**HLS21**



**VLS21**

2nd+ Normally Open Contact

		2nd+ Normally Closed Contact
HLS22	VLS22	

## Pressure and Temperature Switches

Horizontal Symbol	Vertical Symbol	Description
		Pressure Switch, Normally Open
HPS11	VPS11	
		Pressure Switch, Normally Closed
HPS12	VPS12	
		Temperature Switch 1, Normally Open
HTS11	VTS11	
		Temperature Switch 1, Normally Closed
HTS12	VTS12	

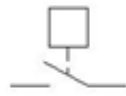

HTS11S18



VTS11S18

Temperature Switch 2, Normally Open



HTS12S18

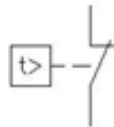

VTS12S18

Temperature Switch 2, Normally Closed

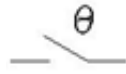

HTS11S74

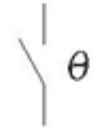

VTS11S74

Temperature Switch 3, Normally Open

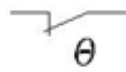

HTS12S74

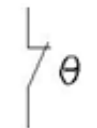

VTS12S74

Temperature Switch 3, Normally Closed



HSW21



VSW21

2nd+ Normally Open Contact



HSW22











VSW22

2nd+ Normally Closed Contact

# Proximity Switches

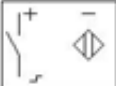
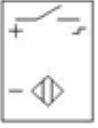
## Inductive Switches

Horizontal Symbol	Vertical Symbol	Description
		Ferrous
<b>HPX11</b>	<b>VPX11</b>	
		Ferrous Proximity Switch, Normally Open
<b>HPX111</b>	<b>VPX111</b>	
		Ferrous Proximity Switch, Normally Closed
<b>HPX121</b>	<b>VPX121</b>	
		Normally Open 3 Wire
<b>HPX111N3</b>	<b>VPX111N3</b>	
		Normally Open 3 Wire 180
<b>HPX111N3R</b>	<b>VPX111N3R</b>	



HPX12IN3



VPX12IN3

Normally Closed 3 Wire



HPX12IN3R



VPX12IN3R

Normally Closed 3 Wire 180

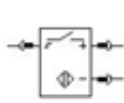

HPX11IN3C

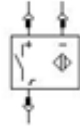

VPX11IN3C

Normally Open 3 Wire with connector



HPX11IN3RC

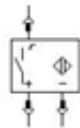

VPX11IN3RC

Normally Open 3 Wire 180 with connector



HPX12IN3C

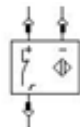

VPX12IN3C

Normally Closed 3 Wire with connector

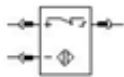



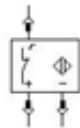

HPX12IN3RC

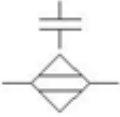
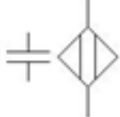
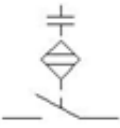
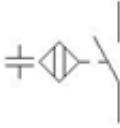
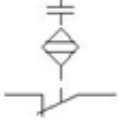

VPX12IN3RC

Normally Closed 3 Wire 180 with connector

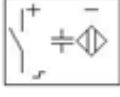
## Capacitive Switches

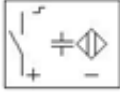
Horizontal Symbol	Vertical Symbol	Description
		Capacitive
<b>HPX1C</b>	<b>VPX1C</b>	
		Capacitive Switch, Normally Open
<b>HPX11C</b>	<b>VPX11C</b>	
		Capacitive Switch, Normally Closed
<b>HPX12C</b>	<b>VPX12C</b>	
		Normally Open 3 Wire
<b>HPX11C3</b>	<b>VPX11C3</b>	
		Normally Open 3 Wire 180
<b>HPX11C3R</b>	<b>VPX11C3R</b>	





HPX12C3



VPX12C3

Normally Closed 3 Wire



HPX12C3R

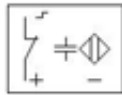

VPX12C3R

Normally Closed 3 Wire 180

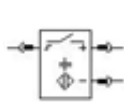

HPX11C3C

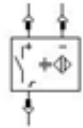

VPX11C3C

Normally Open 3 Wire with connector

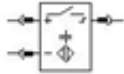

HPX11C3RC

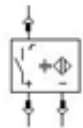

VPX11C3RC

Normally Open 3 Wire 180 with connector



HPX12C3C

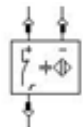

VPX12C3C

Normally Closed 3 Wire with connector





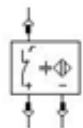







HPX12C3RC

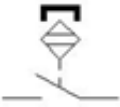

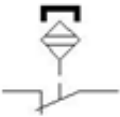
VPX12C3RC

Normally Closed 3 Wire 180 with connector

## Magnetic Switches

Horizontal Symbol	Vertical Symbol	Description
		Magnetic
<b>HPX1M</b>	<b>VPX1M</b>	
		Magnetic Proximity Switch, Normally Open
<b>HPX11M</b>	<b>VPX11M</b>	
		Magnetic Proximity Switch, Normally Closed
<b>HPX12M</b>	<b>VPX12M</b>	
		Normally Open 3 Wire
<b>HPX11M3</b>	<b>VPX11M3</b>	
		Normally Open 3 Wire 180
<b>HPX11M3R</b>	<b>VPX11M3R</b>	



HPX12M3

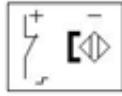

VPX12M3

Normally Closed 3 Wire



HPX12M3R



VPX12M3R

Normally Closed 3 Wire 180

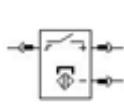

HPX11M3C

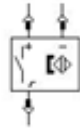

VPX11M3C

Normally Open 3 Wire with connector

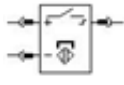

HPX11M3RC

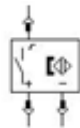

VPX11M3RC

Normally Open 3 Wire 180 with connector

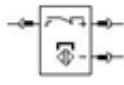

HPX12M3C

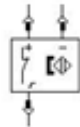

VPX12M3C

Normally Closed 3 Wire with connector



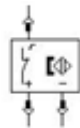

HPX12M3RC



VPX12M3RC

Normally Closed 3 Wire 180 with connector

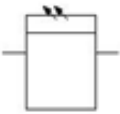
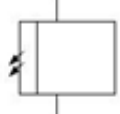
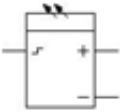
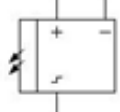
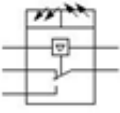
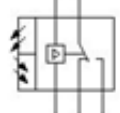
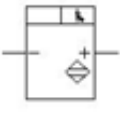
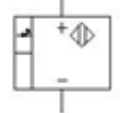
## Photoelectric Emitter Switches

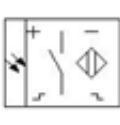
Horizontal Symbol	Vertical Symbol	Description
		Emitter - AC Driven
<b>HPE1B14</b>	<b>VPE1B14</b>	
		Emitter - DC Driven
<b>HPE1B15</b>	<b>VPE1B15</b>	
		Emitter - Receiver with Form C
<b>HPE13B16SC</b>	<b>VPE13B16SC</b>	
		Emitter - DC Driven
<b>HPE1B20</b>	<b>VPE1B20</b>	
		Normally Open 4 wire
<b>HPE11PE4</b>	<b>VPE11PE4</b>	

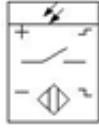

**HPE11PE4R**



**VPE11PE4R**

Normally Open 4 wire 180



**HPE12PE4**

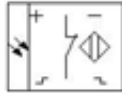

**VPE12PE4**

Normally Closed 4 wire



**HPE12PE4R**

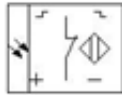

**VPE12PE4R**

Normally Closed 4 wire 180

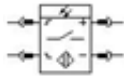

**HPE11PE4C**

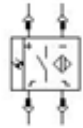

**VPE11PE4C**

Normally Open 4 wire with connector



**HPE11PE4RC**

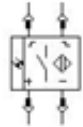

**VPE11PE4RC**

Normally Open 4 wire 180 with connector

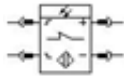

**HPE12PE4C**

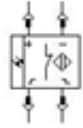



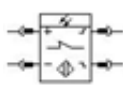
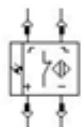

**VPE12PE4C**

Normally Closed 4 wire with connector

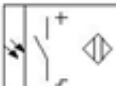
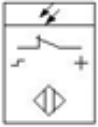
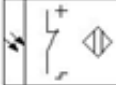
		Normally Closed 4 wire 180 with connector
<b>HPE12PE4RC</b>	<b>VPE12PE4RC</b>	

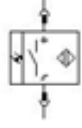
## Photoelectric Receiver Switches

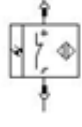
Horizontal Symbol	Vertical Symbol	Description
		Normally Open Receiver 2 wire
<b>HPE11PE2</b>	<b>VPE11PE2</b>	
		Normally Closed Receiver 2 wire
<b>HPE12PE2</b>	<b>VPE12PE2</b>	
		Normally Open Receiver 2 wire with connector
<b>HPE11PE2C</b>	<b>VPE11PE2C</b>	
		Normally Closed Receiver 2 wire with connector
<b>HPE12PE2C</b>	<b>VPE12PE2C</b>	

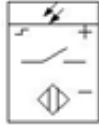

**HPE11PE3**



**VPE11PE3**

Normally Open Receiver 3 wire



**HPE11PE3R**



**VPE11PE3R**

Normally Open Receiver 3 wire 180

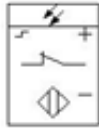

**HPE12PE3**

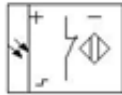

**VPE12PE3**

Normally Closed Receiver 3 wire



**HPE12PE3R**

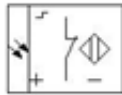

**VPE12PE3R**

Normally Closed Receiver 3 wire 180

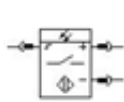

**HPE11PE3C**



**VPE11PE3C**

Normally Open Receiver 3 wire with connector



**HPE11PE3RC**

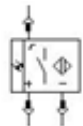

**VPE11PE3RC**

Normally Open Receiver 3 wire 180 with connector

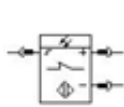

HPE12PE3C

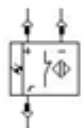

VPE12PE3C

Normally Closed Receiver 3 wire with connector

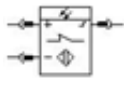

HPE12PE3RC

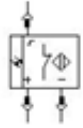

VPE12PE3RC

Normally Closed Receiver 3 wire 180 with connector

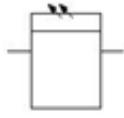

HPE11B14

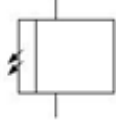

VPE11B14

Normally Open Receiver - AC Driven



HPE12B14

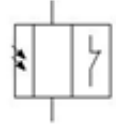

VPE12B14

Normally Closed Receiver - AC Driven



HPE11B15

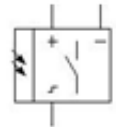

VPE11B15

Normally Open Receiver - DC Driven



HPE12B15

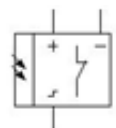

VPE12B15

Normally Closed Receiver - DC Driven



## Photoelectric Emitter/Receiver Switches

Horizontal Symbol	Vertical Symbol	Description
		Normally Open Emitter-Receiver - DC Driven
<b>HPE11B16</b>	<b>VPE11B16</b>	
		Normally Closed Emitter-Receiver - DC Driven
<b>HPE12B16</b>	<b>VPE12B16</b>	
		Normally Open Emitter-Receiver AC/DC Driven 2 PIN
<b>HPE11B22</b>	<b>VPE11B22</b>	
		Normally Closed Emitter-Receiver AC/DC Driven 2 PIN
<b>HPE12B22</b>	<b>VPE12B22</b>	
		Normally Open Emitter-Receiver AC Driven 3 PIN
<b>HPE11B23</b>	<b>VPE11B23</b>	



**HPE12B23**

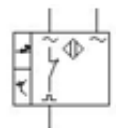

**VPE12B23**

Normally Closed Emitter-Receiver AC Driven 3 PIN

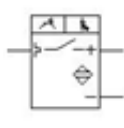

**HPE11B24**

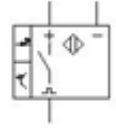

**VPE11B24**

Normally Open Emitter-Receiver DC Driven 3 PIN

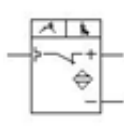

**HPE12B24**

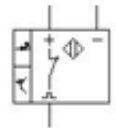

**VPE12B24**

Normally Closed Emitter-Receiver DC Driven 3 PIN

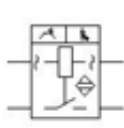

**HPE11B25**

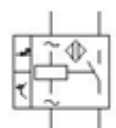

**VPE11B25**

Normally Open Emitter-Receiver AC Driven 4 PIN

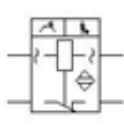

**HPE12B25**

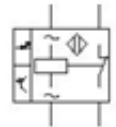

**VPE12B25**

Normally Closed Emitter-Receiver AC Driven 4 PIN

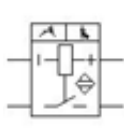

**HPE11B26**

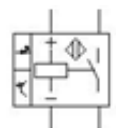

**VPE11B26**

Normally Open Emitter-Receiver DC Driven 4 PIN

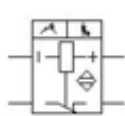

HPE12B26

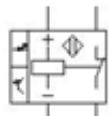

VPE12B26

Normally Closed Emitter-Receiver DC Driven 4 PIN



HPE13B25SC

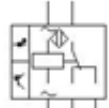

VPE13B25SC

FORM C Emitter-Receiver AC Driven 5 PIN

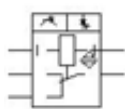

HPE13B26SC

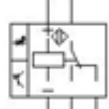

VPE13B26SC

FORM C Emitter-Receiver DC Driven 5 PIN

## Ultrasonic Switches

Horizontal Symbol

Vertical Symbol

Description

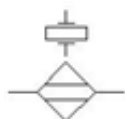

HPX1U

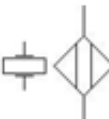

VPX1U

Ultrasonic



HPX11U



VPX11U

Ultrasonic Switch, Normally Open



**HPX12U**

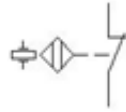

**VPX12U**

Ultrasonic Switch, Normally Closed



**HPX11U3**

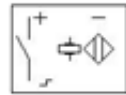

**VPX11U3**

Normally Open 3 Wire



**HPX11U3R**

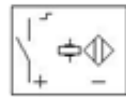

**VPX11U3R**

Normally Open 3 Wire 180

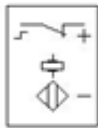

**HPX12U3**

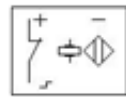

**VPX12U3**

Normally Closed 3 Wire



**HPX12U3R**

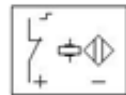

**VPX12U3R**

Normally Closed 3 Wire 180

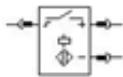

**HPX11U3C**

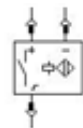

**VPX11U3C**

Normally Open 3 Wire with connector

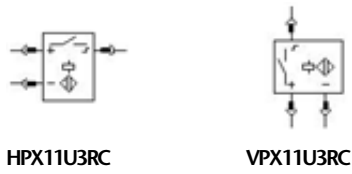

Normally Open 3 Wire 180 with connector

HPX11U3RC

VPX11U3RC

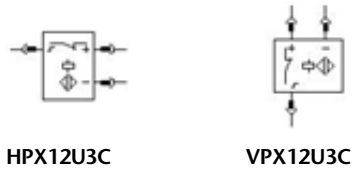

Normally Closed 3 Wire with connector

HPX12U3C

VPX12U3C

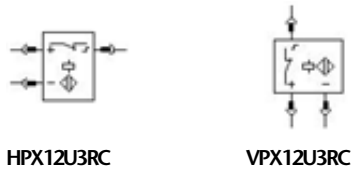

Normally Closed 3 Wire 180 with connector

HPX12U3RC

VPX12U3RC

## Touch Switches

Horizontal Symbol	Vertical Symbol	Description
		Touch
		Touch Sense Proximity Switch, Normally Open



**HPX12TS**



**VPX12TS**

Touch Sense Proximity Switch, Normally Closed

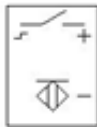

**HPX11TS3**

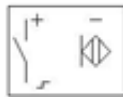

**VPX11TS3**

Normally Open 3 Wire



**HPX11TS3R**



**VPX11TS3R**

Normally Open 3 Wire 180

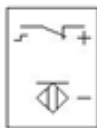

**HPX12TS3**

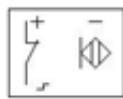

**VPX12TS3**

Normally Closed 3 Wire



**HPX12TS3R**



**VPX12TS3R**

Normally Closed 3 Wire 180

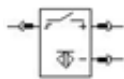

**HPX11TS3C**

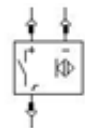

**VPX11TS3C**

Normally Open 3 Wire with Connector

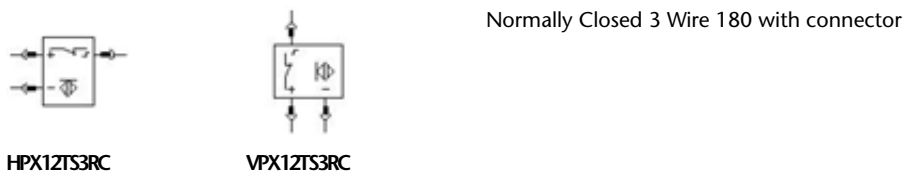
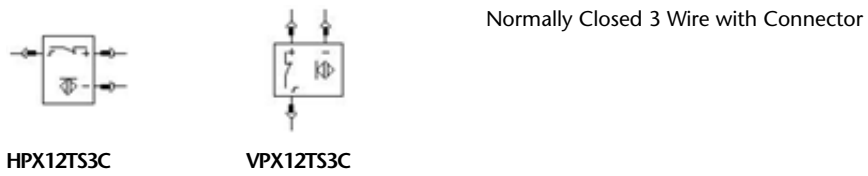
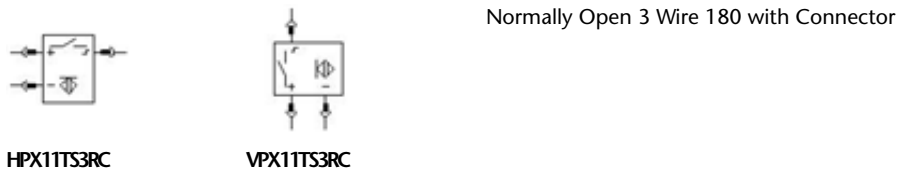

## Miscellaneous Switches

Horizontal Symbol	Vertical Symbol	Description
		Generic Switch, Normally Open
		Generic Switch, Normally Closed

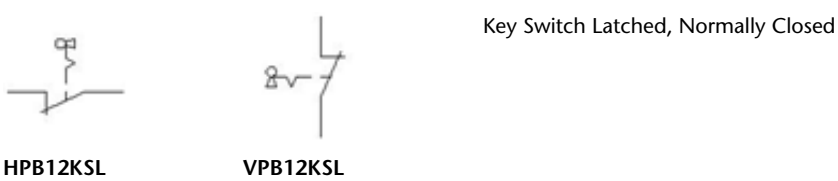
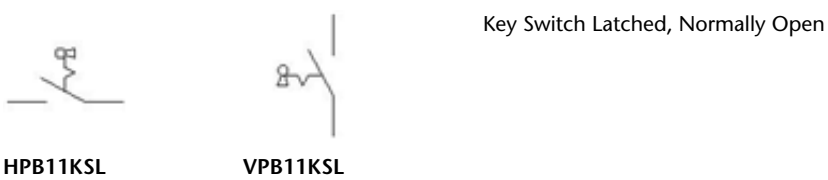
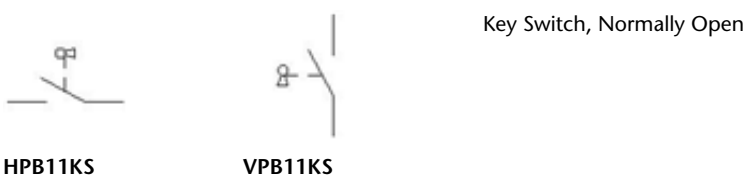
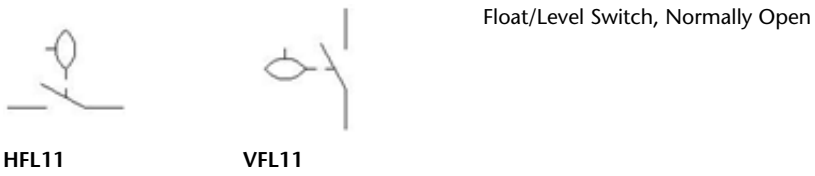



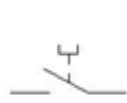

**HPC11**

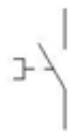

**VPC11**

Pull Cord Switch, Normally Open

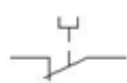

**HPC12**

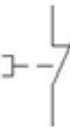

**VPC12**

Pull Cord Switch, Normally Closed

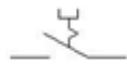

**HPC11L**



**VPC11L**

Pull Cord Switch Latched, Normally Open

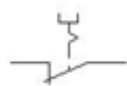

**HPC12L**

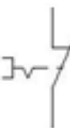

**VPC12L**

Pull Cord Switch Latched, Normally Closed

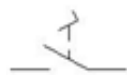

**HFT11**

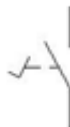

**VFT11**

Foot Switch, Normally Open

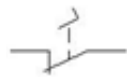

**HFT12**

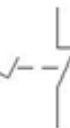

**VFT12**

Foot Switch, Normally Closed

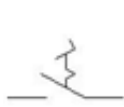

**HFT11L**



**VFT11L**

Foot Switch Latched, Normally Open

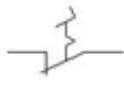

**HFT12L**



**VFT12L**

Foot Switch Latched, Normally Closed

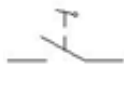

**HPB11LS**

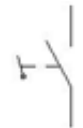

**VPB11LS**

Lever Switch, Normally Open

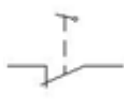

**HPB12LS**



**VPB12LS**

Lever Switch, Normally Closed

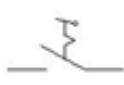

**HPB11LSL**



**VPB11LSL**

Lever Switch Latched, Normally Open

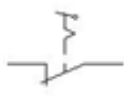

**HPB12LSL**



**VPB12LSL**

Lever Switch Latched, Normally Closed

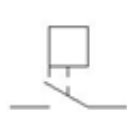

**HFS11**



**VFS11**

Flow Switch Normally Open

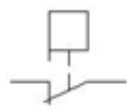

**HFS12**



**VFS12**

Flow Switch Normally Closed

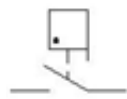

**HFS11S20**



**VFS11S20**

Flow Switch Normally Open - Gas



**HFS12S20**



**VFS12S20**

Flow Switch Normally Closed - Gas

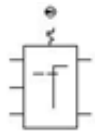

**HSW1S90**

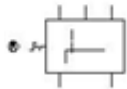

**VSW1S90**

3 Voltage Phase Switch

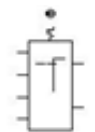

**HSW1S91**

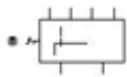

**VSW1S91**

3 Voltage Phase-to-Neutral Switch

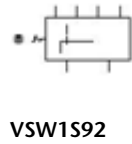
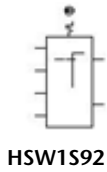

3 Voltage Phase-to-Phase and Phase-to-Neutral Switch

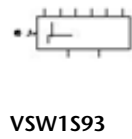

3 Voltage, 2-Network Phase-to-Phase Switch

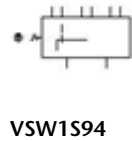
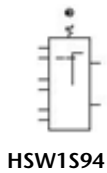

Current Switch For 3 Measurement Points

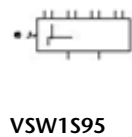
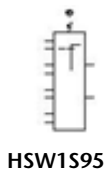

Current Switch For 4 Measurement Points

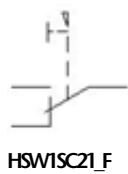

Change-Over Contact with Mechanical Block and Manual Unlatching

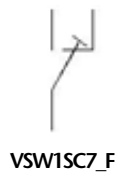

Transfer Make Before Break Contact



HSW1553

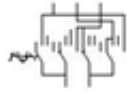

VSW1553

Voltmetric Commutator



HSW21



VSW21

2nd+ Normally Open Contact



HSW22









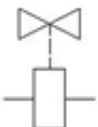
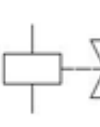

VSW22

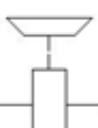
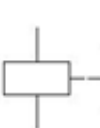





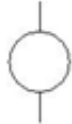

2nd+ Normally Closed Contact

## Solenoids

Horizontal Symbol	Vertical Symbol	Description
		Standard Solenoid Valve
		Standard Solenoid Valve with Connection

 <b>HSV1Y1</b>	 <b>VSV1Y1</b>	<p>Open Solenoid Valve - Closing</p>
 <b>HSV1Y1A</b>	 <b>VSV1Y1A</b>	<p>Open Solenoid Valve - Closing According to Solenoid</p>
 <b>HSV1Y3</b>	 <b>VSV1Y3</b>	<p>Magnetic Brake</p>
 <b>HSV1Y4</b>	 <b>VSV1Y4</b>	<p>Electromagnetic Brake</p>
 <b>HSV21</b>	 <b>VSV21</b>	<p>Solenoid Valve Auxiliary Normally Open Contact</p>
 <b>HSV22</b>	 <b>VSV22</b>	<p>Solenoid Valve Auxiliary Normally Closed Contact</p>

## Instrumentation and Sensors

Horizontal Symbol	Vertical Symbol	Description
 <b>HVM1</b>	 <b>VVM1</b>	Voltage Meter
 <b>HAM1</b>	 <b>VAM1</b>	Amperage Meter
 <b>HIN1PFM</b>	 <b>VIN1PFM</b>	Power Factor Meter
 <b>HIN1PHM</b>	 <b>VIN1PHM</b>	Phase Meter
 <b>HIN1FRM</b>	 <b>VIN1FRM</b>	Frequency Meter

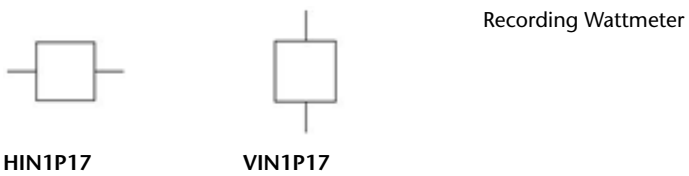
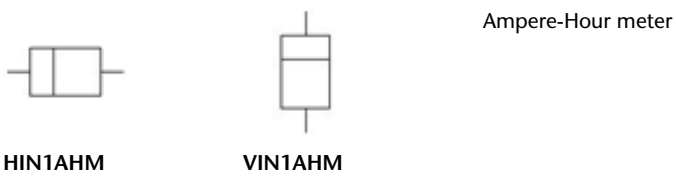
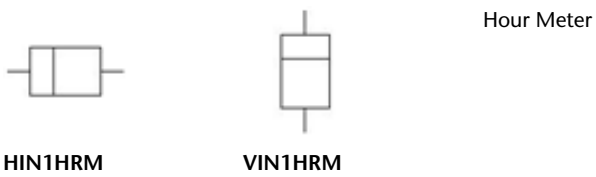
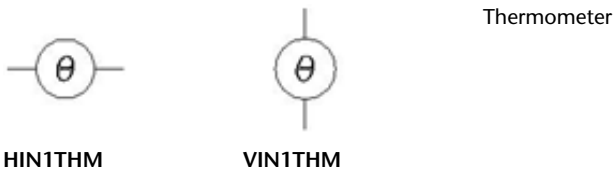



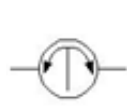

**HIN1P11**



**VIN1P11**

Synchronoscope



**HTC1L**



**VTC1L**

Thermocouple



**HTC1R**



**VTC1R**

Thermocouple

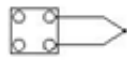

**HTC1LTB**

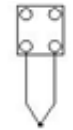

**VTC1LTB**

Thermocouple with Terminal Board

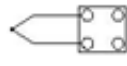

**HTC1RTB**

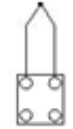

**VTC1RTB**

Thermocouple with Terminal Board

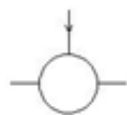

**HIN1P19**

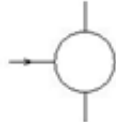

**VIN1P19**

Active Power Indicator

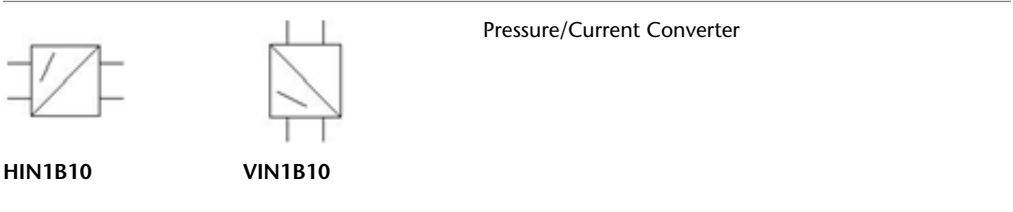
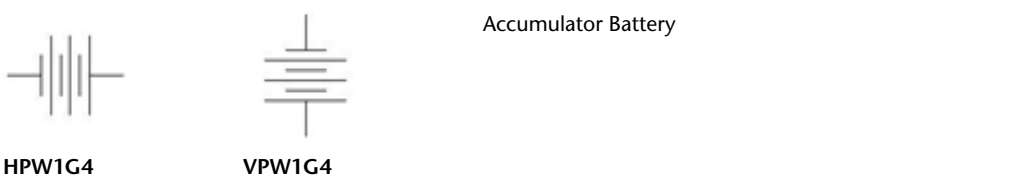
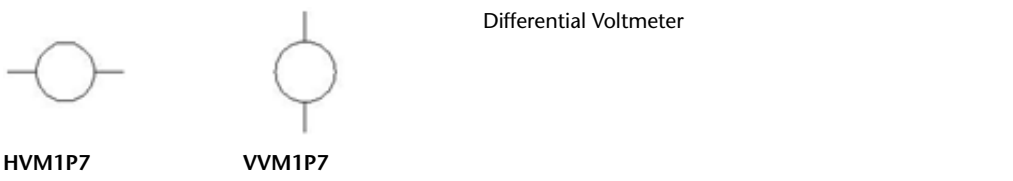
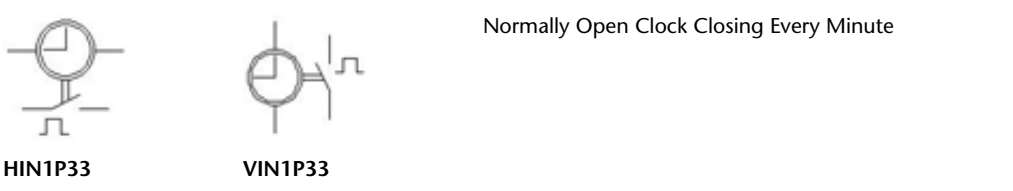
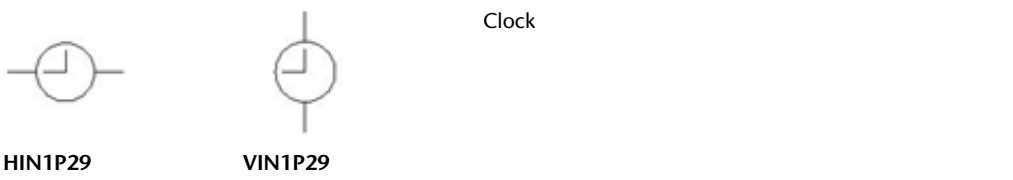
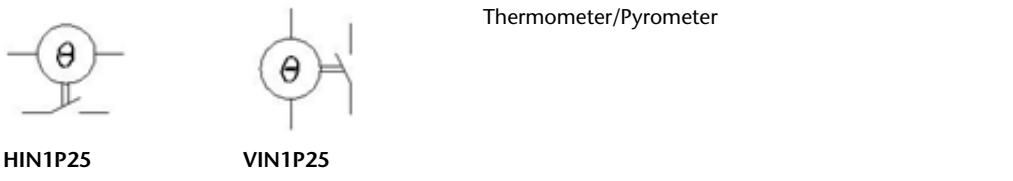

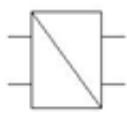

HIN1G1

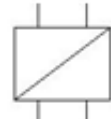

VIN1G1

AC-DC Current Converter Single Phase



HIN1B11



VIN1B11

Tachometric Dynamo



HIN1B12

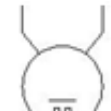

VIN1B12

Tachometric Dynamo - Impulse



HIN1B13



VIN1B13

Tachometric Dynamo - Optical Type

## Qualifying Symbols

### Operating Devices

Symbol	Description
--------	-------------



Positive Operation Direction

Q070109

---



Manual Command General Sign

Q021301

---



Manual Command with Protected Access

Q021302

---



Push Button Command

Q021305

---



Emergency Command

Q021308

---

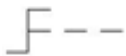

Rotary Command

Q021304

---

Command with Key

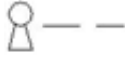

**Q021313**

---

Foot Actuated Command

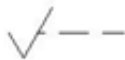

**Q021310**

---

Lever Command



**Q021311**

---

Crank Command



**Q021214**

---

Fixed Manual Command

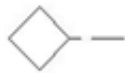

**Q021312**

---

Manual Command with Wheel

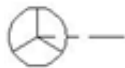

**Q021309**

---

Actuated by the Level of a Fluid



**Q021401**

---

Actuated by the Number of Events

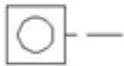

**Q021402**

---

Actuated by a Flow of Fluid



**Q021403**

---

Actuated by a Gas Flow

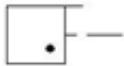

**Q021404**

---

Motorized Command



**Q021326**

---

Timing Command



**Q021327**

---



Command with Roll

**Q021315**

---

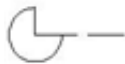

Command with Cam

**Q021316**

---



Cam Profile

**Q021317**

---



Switch Position Function

**Q070106**

---



Switch Position (Flipped)

**Q070106R**

---

Disconnecter Isolator



**Q070103**

---

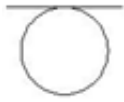

Switch Disconnect Isolator

**Q070104**

---



Circuit Breaker Function

**Q070102**

---



Power Contactor Function

**Q070101**

---



Auto Trip Function

**Q070105**

---



Auto Return (Spring Return)

**Q070107**

---

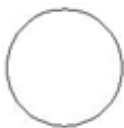

Non Auto Return (Stay)

**Q070108**

---



## Linear Direction of Force or Motion

---

Symbol	Description
	One Way Force Or Movement
Q020401	
	Two Way Force Or Movement
Q020402	
	Transition
Q101101	

## Rotative Direction of Force or Motion

---

Symbol	Description
	One Way Force Or Movement
Q020403	



Two Way Force Or Movement

Q020404

---



Limited Two Way Force Or Movement

Q020405

---

## Propagation Flow or Signal

---

Symbol

Description

---



One Way Propagation

Q020501

---



Two Way Simultaneous Transmission Propagation

Q020502

---



Two Way Alternate Transmission Propagation

Q020503

---

Signal Transmission



Q020504

---

Signal Reception



Q020505

---

## Energy Flow

---

Symbol

Description

---

Outbound Energy Flux



Q020506

---

Inbound Energy Flux



Q020507

---

Inbound and Outbound Energy Flux







Q020508

---

## Effect

---

Symbol	Description
 Q020801	Thermal Effect
 Q020802	Magnetic Effect
 Q020803	Magnetostriction Effect
 Q020804	Magnetic Field Effect

## Radiation

---

Symbol	Description
--------	-------------



Non Ionizing Coherent Electromagnetic Radiation

Q020901

---



Non Ionizing Coherent Radiation

Q020902

---



Ionizing Radiation

Q020903

---

## Fault

---

Symbol

Description

---



Indication Of Presumed Location Of Failure

Q021701

---







Failure For Lack Of Insulation

Q021702

---

## Winding

---

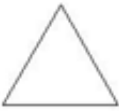
Symbol	Description
 Q060201	2 Phase Winding
 Q060202	3 Phase Partial V Winding
 Q060203	4 Phase Winding with Accessible Ground
 Q060204	3 Phase T Winding
 Q060205	3 Phase Delta Winding

---



3 Phase Open Delta Winding

**Q060206**

---



3 Phase Star Winding

**Q060207**

---



3 Phase Star Winding with Accessible Ground

**Q060208**

---

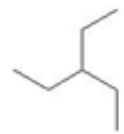

3 Phase Zigzag Winding

**Q060209**

---



Esaphase Winding with Double Delta

**Q060210**

---

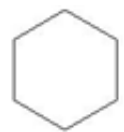

Esaphase Polygonal Winding

**Q060211**

---



Esaphase Star Winding

Q060212

---



Esaphase Double Zigzag Winding with Accessible Ground

Q060213

---

DC Direct Current Indication



Q020201

---

DC Direct Current Indication



Q020203

---

Indication of Rectified Current with an Alternate Component



Q020212

---

AC Alternate Current Indication







Q020204

---

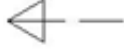

## Mechanical Controls

---

Symbol	Description
	Auto Return
<b>Q021207</b>	
	Auto Non Return Stop Latch
<b>Q021208</b>	
	Stop Latch in Neutral Position
<b>Q021209</b>	
	Stop Latch Engaged
<b>Q021210</b>	
	Interlock Between Two Devices
<b>Q021211</b>	





---

## Mechanical Controls, Latching Device

Symbol	Description
	Latch Device Engaged
<b>Q021212</b>	
	Latch Device in Neutral Position
<b>Q021213</b>	
	Two Ways Latch Device
<b>Q1020603</b>	
	Latch Device with Manual Unlatching
<b>Q1020604</b>	
	Two Ways Latch Device with Key
<b>Q1029603</b>	

## Mechanical Controls, Coupling

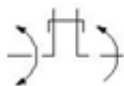







---

Symbol	Description
	Clutch Joint
<b>Q021216</b>	
	Disconnected Joint
<b>Q021217</b>	
	Engaged Joint
<b>Q021218</b>	
	Engaged Joint
<b>Q021219</b>	
	Gear Joint
<b>Q021223</b>	

---

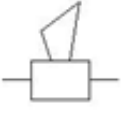
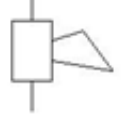
## Miscellaneous

### Miscellaneous

Horizontal Symbol	Vertical Symbol	Description
 HAN1B	 VAN1B	Bell
 HAN1Z	 VAN1Z	Buzzer
 HAN1H	 VAN1H	Horn
 HAN1S	 VAN1S	Siren
 HAN1W	 VAN1W	Whistle



HGND2



VGND2

Earth/Ground



HGND3



VGND3

Functional Earth



HGND4



VGND4

Protective Earth



HGND5

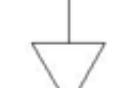

VGND5

Protective equipotential bond

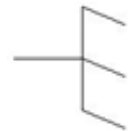

HGND1



VGND1

Functional Equipotential Bond



HBA1



VBA1

Battery



HBA1R



VBA1R

Battery (Flipped)



HPW1\_1PH



VPW1\_1PH

Power Source 1 Phase



HPW1\_3PH



VPW1\_3PH

Power Source 3 Phase

## Electronics

Horizontal Symbol	Vertical Symbol	Description
		Fixed Resistor
		Variable Resistor

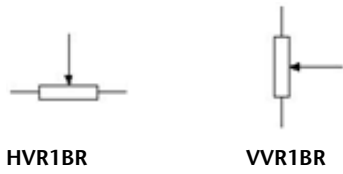

Variable Resistor

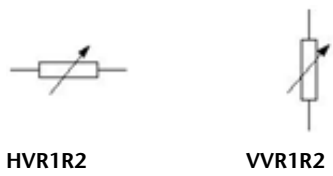

Variable Resistor 2

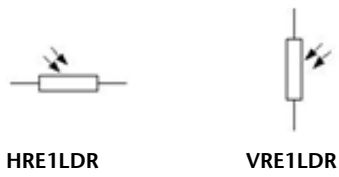

Light dependent

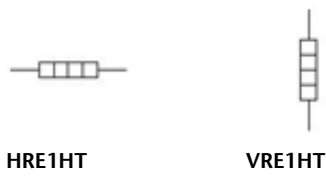

Heater Element

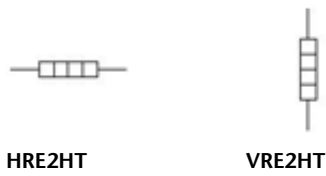

2nd+ Element

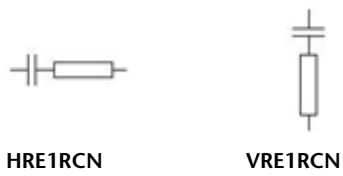

RC Network



**HVR1R3**



**VVR1R3**

Varistor



**HVR1R4**

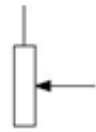

**VVR1R4**

Resistor with Mobile Contact

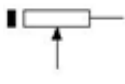

**HVR1R5**

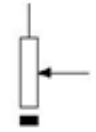

**VVR1R5**

Resistor with Mobile Contact and Disconnecting Position



**HVR1R7**



**VVR1R7**

Shunt



**HVR1R8**



**VVR1R8**

Variable Resistor with Carbon Disks



**HDI1**



**VDI1**

Diode



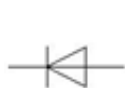

**HDI1R**



**VDI1R**

Diode 180



**HDI1B4**

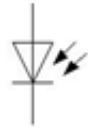

**VDI1B4**

Diode Photosensitive



**HDI1B5**

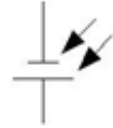

**VDI1B5**

Diode Photosensitive 2

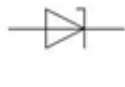

**HDI1V2**



**VDI1V2**

Zener Diode - One Way



**HDI1V3**



**VDI1V3**

Diac Diode - Two Way



**HDI1BR**



**VDI1BR**

Bridge rectifier



HDI1V5

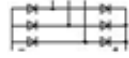

VDI1V5

3 Phase Bridge Rectifier



HDI1V4

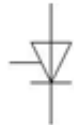

VDI1V4

SCR



HCA1



VCA1

Capacitor



HCA1EL

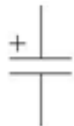

VCA1EL

Electrolytic



HCA1ELR

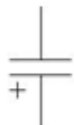

VCA1ELR

Electrolytic 180



HCA1C2



VCA1C2

Feedthrough Capacitor









HDV1B6







VDV1B6

Photosensitive PNP Transistor



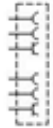

## Cable Markers

Horizontal Symbol	Vertical Symbol	Description
		Cable Marker
HW01	VW01	
		2nd+ Child Marker
HW02	VW02	
		Extra Marker
HT0_CABLE	VT0_CABLE	
		Twisted Pair
HT0_TW	VT0_TW	

## Power Receptacles

Horizontal Symbol	Vertical Symbol	Description
 HCN1RDUP	 VCN1RDUP	Duplex Receptacle
 HCN1RSGL	 VCN1RSGL	Single Receptacle

## Generic Device Boxes

Horizontal Symbol	Vertical Symbol	Description
 HDV1TFL	 VDV1TFL	4 Terminals
 HDV1TC	 VDV1TC	3 Terminals

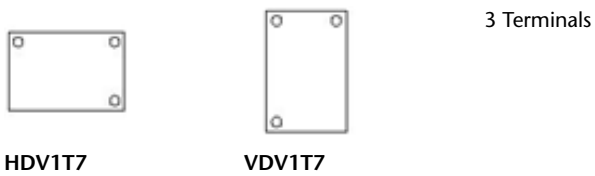
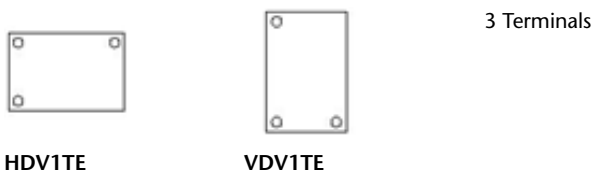
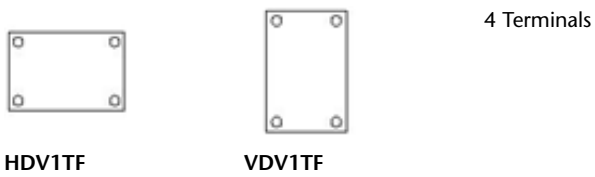
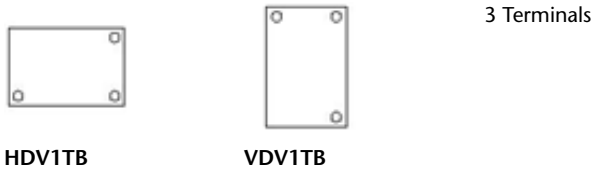

### Stand-alone Cross-reference Symbols

Symbol	Description
--------	-------------

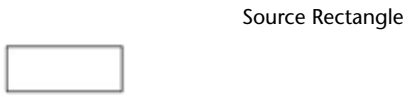

Source Rectangle

**HA2S1\_REF**

---

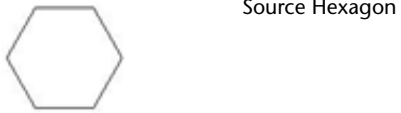

Source Hexagon

**HA3S1\_REF**

---



Source Ellipse

**HAS1\_REF**

---

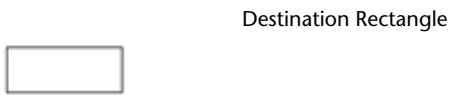

Destination Rectangle

**HA2D1\_REF**

---



Destination Hexagon

**HA3D1\_REF**

---







Destination Ellipse

**HASD1\_REF**

---

## Wire Arrows - Reference Only

---

Symbol	Description
 HA1X1	Generic Arrow - Left
 HA1X2	Generic Arrow - Up
 HA1X3	Generic Arrow - Right
 HA1X4	Generic Arrow - Down
 HA1X1Y	Arrow Tail - Left

---



Arrow Tail - Up

HA1X2Y



Arrow Tail - Right

HA1X3Y



Arrow Tail - Down

HA1X4Y



## Splice Symbols

Horizontal Symbol	Vertical Symbol	Description
		Splice
HSP1001	VSP1001	

## Annunciations

Horizontal Symbol	Vertical Symbol	Description
-------------------	-----------------	-------------



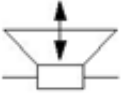
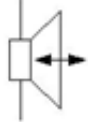

		Loudspeaker
HAN1B7	VAN1B7	

		Loudspeaker - Microphone
HAN1B8	VAN1B8	

		Microphone
HAN1B9	VAN1B9	

## One-Line Components

### Connector

Horizontal Symbol	Vertical Symbol	Description
		Jack/Plug
HC01PJ_1-	VC01PJ_1-	

### Motor Control

Horizontal Symbol	Vertical Symbol	Description
-------------------	-----------------	-------------

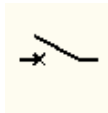

HCB11\_1-

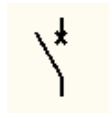

VCB11\_1-

Circuit breaker

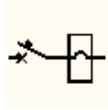

HCB11\_1M-

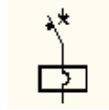

VCB11\_1M-

Motor circuit protector

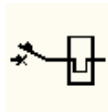

HCB11TH\_1-

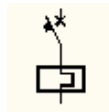

VCB11TH\_1-

Thermal circuit breaker

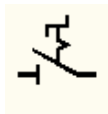

HDS11\_1-

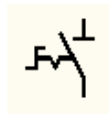

VDS11\_1-

Disconnect

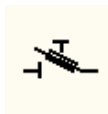

HDS11F\_1-

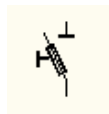

VDS11F\_1-

Fused disconnect

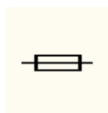



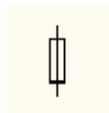

HFU1\_1-



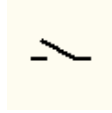
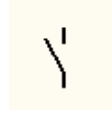
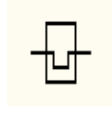

VFU1\_1-

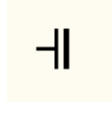
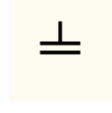
Fuse

		Motor
HMO13_1-	VMO13_1-	
		Motor starter
HMS11_1-	VMS11_1-	
		Overload
HOL1_1-	VOL1_1-	
		Capacitor
HCA113_1-	VCA113_1-	

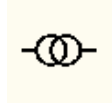
## Transformer

Horizontal Symbol	Vertical Symbol	Description
		Transformer 1
HXF1_1-	VXF1_1-	





HXF2\_1-





VXF2\_1-

Transformer 2

## Terminal



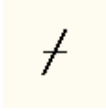
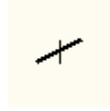

Horizontal Symbol	Vertical Symbol	Description
		Square terminal
HT0001_1-	VT0001_1-	

		Round terminal
HT0002_1-	VT0002_1-	



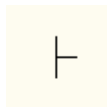

## Cable Marker

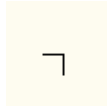
Horizontal Symbol	Vertical Symbol	Description
		Cable marker
HW01_1-	VW01_1-	

## Bus-tap

Horizontal Symbol	Vertical Symbol	Description
		Bus-tap - main/dot
<b>HDM1_BT_1-</b>	<b>VDM1_BT_1-</b>	
		Bus-tap - dual/tee
<b>HDM1_BT_1-</b>	<b>VDM1_BT_1-</b>	
		Bus-tap - dual/corner
<b>HDM1_BT_1-</b>	<b>VDM1_BT_1-</b>	

## Miscellaneous

Horizontal Symbol	Vertical Symbol	Description
		Power receptacle
<b>HCOMR_1-</b>	<b>VCOMR_1-</b>	
		Generic load
<b>HDM1_1-</b>	<b>VDV1_1-</b>	



## Generate PLC layout modules

AutoCAD Electrical can generate any of hundreds of different PLC I/O modules on demand, in a variety of different graphical styles, all without a single, complete I/O module library symbol resident on the system. Modules automatically adapt to the underlying ladder rung spacing, whatever that value is, and can stretch or break into two or more pieces at insertion time. It is possible because AutoCAD Electrical generates PLC I/O modules through a parametric generation technique driven by a PLC database (ACE\_PLC.MDB).

The PLC database contains the stack sequence and text values to annotate onto each symbol in the stack. As AutoCAD Electrical builds the module, it reads the underlying ladder rung spacing and spreads out the stack or compresses it to match the rung spacing. During the insertion process, you can interrupt it to break the module and then restart it at a different location.

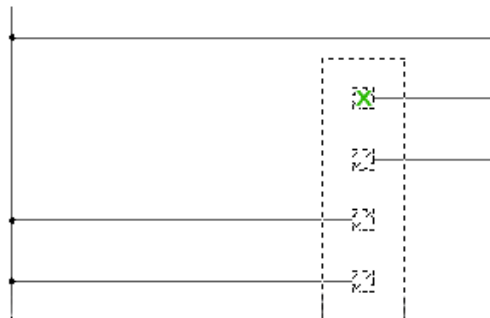

## Parametric PLC symbols vs. Full Units

Parametric PLC symbols are stored in

- **Windows XP:** \Documents and Settings\All Users\Documents\Autodesk\Acade {version}\libs\{library}\
- **Windows Vista, Windows 7:** \Users\Public\Documents\Autodesk\Acade {version}\libs\{library}\

The file names begin with the characters "HP" (Horizontal ladder rungs / PLC) or "VP" (Vertical ladder rungs) followed by a digit that corresponds to a PLC I/O style number. Each symbol is a building block with a different arrangement of attributes and wire connection points. AutoCAD Electrical selects the appropriate symbols to use, stacks them together in the order defined by the data file, and produces a completed I/O module.

The PLC database file (ace\_plc.mdb) is used to drive the PLC I/O module generation process. You can modify the PLC database file manually or using the [PLC Database File Editor](#) on page 603 (recommended method). The AutoCAD Electrical PLC database file (ace\_plc.mdb) is installed in

- **Windows XP:** C:\Documents and Settings\{username}\My Documents\Acade {version}\AeData\Plc
- **Windows Vista, Windows 7:** C:\Users\{username}\Documents\Acade {version}\AeData\Plc

Each Parametric PLC symbol is a building block with a different arrangement of attributes and wire connection points. AutoCAD Electrical selects the appropriate symbols to use, stacks them together in the order defined by the parametric data file, and produces a completed I/O module. AutoCAD Electrical inserts the symbols based upon the rung spacing of the underlying ladder, explodes them, draws a rectangular box around the entire assembly, creates a single block out of the collection, and annotates the attributes of the new module.

Some PLC units may not lend themselves well to parametric generation. If a PLC module symbol is built with the appropriate attributes in place and the symbol name follows naming convention of AutoCAD Electrical (the block name begins with "PLCIO"), it can be inserted as a single unit using the [Insert PLC \(Full Units\)](#) on page 591 command. The selected unit inserts into the ladder, breaks the wires, and then reconnects.

## PLC parametric selection

Inserts a parametrically generated PLC I/O module.



**Ribbon:** Schematic tab ► Insert Components panel ► Insert PLC

drop-down ► Insert PLC (Parametric).



**Toolbar:** Main Electrical

**Menu:** Components ► Insert PLC Modules ► Insert PLC (Parametric)

**Command entry:** AEPLCP

Generate PLC I/O modules on demand in a variety of graphical styles with no complete I/O module library symbols. Modules adapt to the underlying ladder rung spacing. You can stretch or break them into two or more pieces at insertion time. A PLC database, ACE\_PLC.MDB, drives generation. It contains the stack sequence and the text values to annotate onto each symbol in the stack.

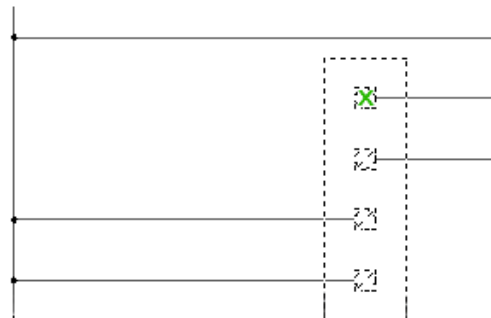

### Manufacturer Catalog tree

Provides a complete list of the PLC modules available to AutoCAD Electrical. The Manufacturer Catalog tree is compiled from the database file, "ace\_plc.mdb."

### Module List

Displays the defined modules. Once you select a module type or a specific module from the Manufacturer Catalog tree, AutoCAD Electrical reads through the information contained in the database. Select from this list to begin the PLC module insertion process.

## Graphics Style

Specifies the graphical appearance of the PLC module. Styles 1-5 are provided with AutoCAD Electrical. Styles 6-9 may be user-defined. Select a style number and a sample portion of a PLC module displays.

To create a user-defined style: There are about two dozen symbols associated with each style. They are located in

- **Windows XP:** \Documents and Settings\All Users\Documents\Autodesk\Acade {version}\Libs\{library}\
- **Windows Vista, Windows 7:** \Users\Public\Documents\Autodesk\Acade {version}\Libs\{library}\

The symbols carry the file name "HP?.dwg" or "VP?.dwg" where "?" is the style number. An easy way to create a style is to copy the symbols of an existing style to one of the unused style numbers (6, 7, 8, or 9) and edit each library symbol.

## Scale

Specifies the scale for the PLC module. You can also specify to apply a border to the PLC module upon insertion.

## Module layout

 **Ribbon:** Schematic tab ► Insert Components panel ► Insert PLC

drop-down ► Insert PLC (Parametric).



 **Toolbar:** Main Electrical



 **Menu:** Components ► Insert PLC Modules ► Insert PLC (Parametric)

 **Command entry:** AEPLCP

Select the PLC module to insert, click OK, and place the PLC in the drawing.

## Spacing

Specifies the spacing for the module. The module defaults to the underlying rung spacing. If you wish to override this spacing, modify the number shown in the spacing edit box. The arrows below this box increment the number by

the rung spacing. For example, if the rung spacing is 0.5 then each time you click ">" the number increases by 0.5.

### **I/O points**

Specifies whether to include all of the points or break the module into many pieces. You can break a module into as many pieces as you want at insertion time. It is useful for a module that does not fit into a single ladder column. You can also add extra space between adjacent I/O points. It allows for the extra room needed for parallel components. Select Allow Spacers/Breaks and after each I/O you have the opportunity to insert a space, break the module, or insert the rest normally. If the module's definition (in the Attributes column of the Module Terminal Information table of the ace\_plc.mdb file or by selecting the check box in the Break After column of the PLC Database File Editor dialog box) carries a ";\SPECIAL=BREAK" flag, then the Note highlights and the module automatically prompts you for permission to break at the correct point during module insertion.

### **Include unused/extra connections**

Specifies to include all of the extra connections to the PLC. Some modules may have terminals that are not used (that is, dummy terminals with no electrical connection). Unused terminals are skipped by default. This results in the most compact representation of the module, but you can set up the PLC modules to show unused terminals optionally. It is done by adding in "\SPECIAL=INCLUDE" and "\SPECIAL=EXCLUDE" flags (in the Attributes column of the Module Terminal Information table of the ace\_plc.mdb file) or by selecting "When Including Unused" or "When Excluding Unused" in the Show column of the PLC Database File Editor dialog box.

## **Insert PLC modules**

### **Insert PLC modules**

In AutoCAD Electrical, you can insert either PLC I/O points as independent symbols or as a complete PLC module into your drawing.

- 1 Click Schematic tab ► Insert Components panel ► Insert PLC



drop-down ► Insert PLC (Full Units).

- 2 In the PLC Fixed Units dialog box, select the PLC module to insert.

- 3 Specify the insertion point on the drawing.
- 4 Add or edit any information in the Edit PLC Module dialog box, and click OK.

## Edit PLC module

Use this dialog box when inserting or editing a PLC module. Specify the values you need and press OK. The values are then annotated onto the selected module.

---

**NOTE** Editing the first address, I/O point address, or catalog information for a PLC module that was imported using the Unity Pro Export to Spreadsheet tool may result in problems when you export the data back to Unity Pro. An alert displays to ask whether you want to proceed with the changes.

---

 **Ribbon:** Schematic tab ► Edit Components panel ► Edit Components

drop-down ► Edit.



 **Toolbar:** Main Electrical

 **Menu:** Components ► Edit Component

 **Command entry:** AEEDITCOMPONENT

Select the PLC module to edit.

### Addressing

<b>First Address</b>	Specifies the first I/O address for the PLC module.
<b>List</b>	Lists the available I/O addresses to select from. When you select an I/O address from the list the I/O Point Description: Address automatically updates.
<b>Used: Drawing or Project</b>	Lists any I/O points already assigned to the drawing or project. Select a tag from the list to copy, or to increment for this new component.

**Tag**

Specifies a unique identifier assigned to each I/O point. The tag value can be manually typed in the edit box.

**Options**

Substitutes a fixed text string for the %F part of the tag format. Retag Component can then use this override format value to calculate a new tag for the PLC module. For example, a certain PLC module must always have an "IO" family tag value instead of "PLC" so that retag, for example, assigns IO-100 instead of PLC100. To achieve this tag override you would enter "IO-%N" for the tag override format.

**Line1/Line2**

Specifies optional description text for the module. May be used to identify the relative location of the module in the I/O assembly (example: Rack # and Slot #).

**Manufacturer**

Lists the manufacturer number for the I/O point. Enter a value or select one from the Catalog lookup.

**Catalog**

Lists the catalog number for the I/O point. Enter a value or select one from the Catalog lookup.

**Assembly**

Lists the assembly code for the I/O point. The Assembly code is used to link multiple part numbers together.

**Catalog Lookup**

Opens the Catalog Information dialog box.

**Manufacturer**

Lists the manufacturer number for the component. Enter a value or select one from the Catalog lookup.

**Catalog**

Lists the catalog number for the component. Enter a value or select one from the Catalog lookup.

<b>Assembly</b>	Lists the assembly code for the component. The Assembly code is used to link multiple part numbers together.
<b>Item</b>	Specifies a unique identifier assigned to each component. The tag value can be manually typed in the edit box.
<b>Catalog Lookup</b>	Opens the PLCIO table in the catalog database from which you can manually enter or select the Manufacturer or Catalog values. Search the database for a specific catalog item to assign to the selected component.
<b>Drawing</b>	Lists the part numbers used for similar components in the current drawing.
<b>Project</b>	<p>Lists the part numbers used for similar components in the project. You can search in the active project, another project, or an external file.</p> <ul style="list-style-type: none"> <li>■ <b>Active project:</b> All the drawings in the current project are scanned and the results are listed in a dialog box. Select from the list to assign your new component with a catalog number that is consistent with other similar components in the project.</li> <li>■ <b>Other project:</b> Scans each listed drawing in a previous project for the target component type and returns the catalog information in a subdialog box. Make your catalog assignment by picking from the dialog box list.</li> <li>■ <b>External file:</b> You can pull catalog assignments from a generic ASCII file created by a word processor or output from a spreadsheet or database program. A dialog box displays the contents of the selected text file. Find and highlight the appropriate entry. AutoCAD Electrical reads the line of text from the file and breaks it into its component parts. They are displayed in the left-hand dialog box list. For each relevant item, highlight it, and then pick the appropriate category button in the center column. The highlighted item is transferred to the corresponding category (and then to the Insert/Edit dialog box once OK is clicked).</li> </ul>
<b>Multiple BOM</b>	Inserts or edits extra catalog part numbers on to the selected component. You can add up to 99 part numbers to any component. These multiple BOM part numbers appear as sub-assembly

part numbers to the main catalog part number in the various BOM and component reports.

**Catalog Check**

Displays what the selected item looks like in a Bill of Material template.

**Description**

Optional line of description text. May be used to identify the module type (for example, "16 Discrete Inputs - 24VDC")

**I/O Point Description**

**Address**

Specifies the I/O address assignment.

**Description 1-5**

Optional description text. Enter up to five lines of description attribute text.

**Next/Pick**

Selects a description from a module on the current drawing.

**List descriptions**

Lists the I/O point descriptions currently assigned to each I/O point on the module or connected, wired devices in a pick list. Selecting one of the buttons next to this displays a different list of description in the box below.

**I/O**

Lists I/O point descriptions used so far on the module. Pick to copy.

**Wired Devices**

Lists descriptions of wired devices that are found to be connected to the I/O module. Pick to copy the description.

**External File**

Displays contents of an external comma-delimited ASCII text file of I/O point descriptions. Pick an entry in the file and then copy the values to edit boxes in the Edit dialog box.

**Installation/Location codes**

Changes the installation or location codes. You can search the current drawing or entire project for installation and location codes. A quick read of all the current or selected drawing files is done and a list of codes used so far is returned. Select from the list to update the module automatically with the installation or location code.

### **Pins**

Assigns pin numbers to the pins that are physically located on the module.

### **Show/Edit Miscellaneous**

View or edit any attributes that are not predefined AutoCAD Electrical attributes.

### **Ratings**

Specifies values for each ratings attribute. You can enter up to 12 ratings attributes on a module. Select Defaults to display a list of default values.

---

**NOTE** If Ratings is unavailable, the module you are editing does not carry rating attributes.

---

## **Overview of the PLC database file**

You can modify the PLC database file manually or using the [PLC Database File Editor](#) on page 603 (recommended method). The AutoCAD Electrical PLC database file (ace\_plc.mdb) is installed in

- **Windows XP:** C:\Documents and Settings\{username}\My Documents\Acade {version}\AeData\Plc
- **Windows Vista, Windows 7:** C:\Users\{username}\Documents\Acade {version}\AeData\Plc

By default the AutoCAD Electrical PLC database file contains the "PLC\_Manufacturer", "PLC\_MSG" and "PLC\_Styles" tables in addition to several module specification and module terminal information tables.

---

**NOTE** PLC Parametric build symbols are best used on ANSI D-Size and IEC A1 page sizes.

---

<b>PLC_Manufacturer</b>	This table lists the Manufacturer, Series, Type, and Table Name.
<b>PLC_MSG</b>	This table is for internal use only. We recommend that you do not edit this table.
<b>PLC_Styles</b>	This table lists the box settings on a per-style basis.



There are two tables for each module type. The Module Specification table contains information such as the model number, type, description, rating, and rectangle offset values. The Module Terminal Information table (ends with "\_Data") contains terminal information such as code value, terminal sequence number, block name, and terminal attributes.

### Module Specification table

*Example: "allen-bradley\_1746\_analog\_input"*

This file lists information that appears in the selection line of the module listed in the bottom half of the PLC Module Selection dialog box.

<b>CODE</b>	Model number
<b>TYPE</b>	Module type
<b>POINTS</b>	Number of I/O points
<b>DESCRIPTION</b>	Description displayed in selection dialog box
<b>ADDRESS_BASE</b>	Base numbering value (octal, decimal, hex)
<b>ADDRESS_FORMAT</b>	Reserved for future use; currently empty
<b>OPTIONAL_BLOCK</b>	Optional block to insert at bottom of module (i.e. DIP switches)
<b>RATING</b>	Voltage rating
<b>LISP</b>	AutoLISP file to run at module insertion time
<b>BOX_RIGHT, BOX_LEFT, BOX_TOP_BOX_BOTTOM BOX_SPLIT_BOTTOM, BOX_SPLIT_TOP METRIC_BOX_RIGHT, METRIC_BOX_LEFT, METRIC_BOX_TOP, METRIC_BOX_BOTTOM METRIC_BOX_SPLIT_BOTTOM, MET- RIC_BOX_SPLIT_TOP</b>	Offsets (right, left, top, and bottom) for the rectangle that is drawn around the finished stack of symbols to create an overall module. <hr/> <b>NOTE</b> You can suppress the rectangular box around the finished module by removing these entries from the specification table of a module. <hr/>
<b>CATEGORY</b>	Specifies the insertion position for the module when inserted during the Spreadsheet to PLC I/O utility.

- 1 = inserted near the right or bottom bus line of the ladder.
- 2 = inserted near the left or top bus line of the ladder.
- 3 = inserted centered between the bus lines of the ladder.

The following are optional parameters for parametric build symbol placement:

**Box color/linetype/layer**

You can instruct AutoCAD Electrical to draw the rectangular box using non-default line properties for color, layer, linetype, or ltscale. Encode this information as a series of keywords as if you were using the CHPROP command in AutoCAD to make the change. The keywords are encoded into the "BOX\_RIGHT", "BOX\_LEFT", "BOX\_TOP" and "BOX\_BOTTOM" entries in the specification table of a module. For example, the following makes the left and right-hand sides of the enclosing box cyan using linetype 'Hidden2' and the top and bottom blue using the default linetype:

```
BOX_RIGHT=0.5 COLOR CYAN LTYPE HIDDEN2
BOX_LEFT=0.5 COLOR CYAN LTYPE HIDDEN2
BOX_TOP=0.5 COLOR BLUE
BOX_BOTTOM=0.375 COLOR BLUE
```

**Module Terminal Information table (ends with \_Data)**

*Example: "allen-bradley\_1746\_analog\_input\_Data"*

This file contains terminal information for the module type.

<b>CODE</b>	Catalog number of the module
<b>SEQUENCE</b>	Terminal sequence number
<b>BLOCK</b>	Block name used for insertion. The "?" gets filled in during insertion and the block name uses either a "H" or "V" depending on the selected orientation.
<b>ATTRIBUTES</b>	Optional attributes for the terminal. Includes user attributes, %%x prompt values, address prefix or suffix, non-sequential addresses,

breaks, reprompt of I/O address, including unused terminals and special spacing.

The following are optional parameters for parametric build symbol placement:

#### Use of %%x prompt values

After entering values such as rack, group or slot, the values are available for use on any subsequent I/O point of the module. If you want to use each I/O point's TERMDISC\_ attribute to carry the I/O address in Rack/Group, bit number format, do the following:

- 1 Prompt for Rack and Group values in the first entry of the module.  
%%1PROMPT=Rack number;%%2PROMPT=Group number.
- 2 Encode the TERMDISC\_ value using %%1, %%2, and a bit number suffix.  
TERMDISC\_1:%%1%%2/00 for the first I/O point  
TERMDISC\_2:%%1%%2/01 for the 2nd I/O point

#### User Attributes

You can add and annotate your own attributes to the parametric symbols if they are referenced in the Module Terminal Information table.

#### Address prefix or suffix

You can include a prefix or suffix to each address value that is inserted. For example, if you want "IN-" to come in as a prefix for inputs on a given module you would edit the database file and add ";TAGA\_=IN-%%N" to each I/O parametric data entry in the block of data of the module. The %%N represents the calculated I/O address and the "IN-" is the prefix that gets added.

#### Dealing with non-sequential addresses

Some modules may have I/O address assignments that do not sequentially increment from one terminal to the next. Use the "%%A" flag to represent the beginning address of the module. In the example shown below, the address sequence is non-sequential. Note the use of the "TAGA\_=%%A+ <some value>" flags.

CODE	BLOCK	ATTRIBUTES
D2-08ND3	HP?--WLR	TERM_=C,C;MFG=PLC-DIRECT;CAT=D2-08ND3;...
D2-08ND3	HP?WA-DQ	TERM_=0

CODE	BLOCK	ATTRIBUTES
D2-08ND3	HP?WA-DR	TERM_=4;TAGA_=%%A+4
D2-08ND3	HP?WA-DQ	TERM_=1;TAGA_=%%A+1
D2-08ND3	HP?WA-DR	TERM_=5;TAGA_=%%A+5
D2-08ND3	HP?WA-DQ	TERM_=2;TAGA_=%%A+2
D2-08ND3	HP?WA-DR	TERM_=6;TAGA_=%%A+6
D2-08ND3	HP?WA-DQ	TERM_=3;TAGA_=%%A+3
D2-08ND3	HP?WA-DR	TERM_=7;TAGA_=%%A+7

### Forcing a break

You can pre-define a module break point in the Module Terminal Information table. Add "\SPECIAL=BREAK" on the line where you want the break to occur.

20 terminals are allowed on the parametric build symbols by default. If the module exceeds 20 terminals the break is placed in a logical location; such as after a grouping of I/O addressing. For example, a 32 I/O point card could have 36 terminals on it, the module definition would run the break command at 18 (after the first set of 16 I/O addresses). If you want to break the module sooner you can use the PLC Database File Editor to add the break command or do the following in the Module Terminal Information table.

```
HP?WA-D;TERM_07\SPECIAL=BREAK
```

### Triggering for reprompt of I/O address

Some modules include inputs and outputs. You can trigger AutoCAD Electrical to prompt for a new beginning address number when the parametric build flips from inputs to outputs or vice versa. Add "\SPECIAL=ADDR\_OUT" on the line where you want a prompt for a new output address or add "\SPECIAL=ADDR\_IN" if you want a prompt for a new beginning input address.

### Including unused terminals

Some modules may have terminals that are not used. Unused terminals are skipped by default, resulting in a compact representation of the module. You can set up the PLC database file to show unused terminals optionally by adding "\SPECIAL\_INCLUDE" and "\SPECIAL\_EXCLUDE" in the Module Terminal Information table.

## Special spacing

Normally when AutoCAD Electrical generates a PLC module, it uses the current rung spacing for I/O and wire connection point spacing. You can override it by using the "\SPECIAL=SPACINGFACTOR=<val>" in the Module Terminal Information table. When AutoCAD Electrical sees it on an I/O point or wire connection entry line, it uses a factor of the rung spacing. For example, a "\SPECIAL=SPACINGFACTOR=0.5" for a given I/O or wire connection entry flags AutoCAD Electrical to insert this point down 0.5 rung spacing instead of a full rung spacing. A value of 1.5 inserts the point down an extra half run spacing than normal while 0.0 inserts the I/O point at the same location as the preceding one.

For example, the following four lines in a parametric data file inserts four points spread out over four-ladder rung spaces:

```
HP?WA-D;TERM_=01
```

```
HP?W--;TERM_=COM
```

```
HP?W--;TERM_=VDC
```

```
HP?WA-D;TERM_=02
```

If you want the two middle terminal symbols to group into one rung space instead of taking up two spaces, edit the file to read:

```
HP?WA-D;TERM_=01
```



```
HP?W--;TERM_=COM;\SPECIAL=SPACINGFACTOR=0.5
```

```
HP?W--;TERM_=VDC;\SPECIAL=SPACINGFACTOR=0.5
```

```
HP?WA-D;TERM_=02
```

## Copy modules

You can copy an entire module into a new module using the PLC Database File Editor.

- 1 Click Schematic tab > Other Tools panel >  > Database Editors  
drop-down >  PLC Database File Editor.
- 2 In the PLC selection list, right-click on the module that you want to copy from and select Copy.

- 3 Right-click the Type in the tree that you want to copy to.  
For example, if you want to copy the new module to Allen-Bradley, 1746, Discrete Input, you would find Discrete Input under Allen Bradley ► 1746 in the tree.
- 4 Select Paste Module.  
If you attempt to copy a PLC Module part number into a PLC Type that already has a module with the same name, the PLC Database File Editor prompts you to change the name of the new module being copied.
- 5 To change the name for the module, right-click the module, select Rename, and enter a new name.

## Adjust the terminal information

When you highlight an exiting module part number in the PLC Database File Editor tree structure, the terminal grid control becomes populated with the terminal information previously defined for the module.

- 1 Click Schematic tab ► Other Tools panel ►  ► Database Editors drop-down ► PLC Database File Editor. 

- 2 Select the module to modify from the tree structure.  
Inside the terminal grid control there are drop-down list boxes, text boxes, and context menus that you can use to modify the terminal information.
- 3 Select the terminals to modify. You can select multiple fields to edit at the same time by dragging your mouse across contiguous fields or by holding down the Control key while selecting non-contiguous fields. You can also select multiple terminals if you want the terminals to carry the same information.
  - If you want to modify the terminals one at a time, either make your changes on the PLC Database File Editor dialog box (using the drop-down list boxes or text boxes) or select a single terminal (making sure to select the entire row if you want to change more than one field), click the right mouse button, and select Edit Terminal from the menu.

- If you want to modify multiple terminals at the same time, select the terminals, click the right mouse button, and select Edit Terminal from the menu.
- 4 In the Select Terminal Information dialog box, make any modifications to the selected terminals. Changes that you make in this box will be applied to all of the selected terminals in the terminal grid control.
  - 5 Click OK to save your changes and return to the PLC Database File Editor.
  - 6 Click Done to save your changes and exit the dialog box or click Done/Insert to save your changes and insert the PLC module into your drawing.

## PLC database file editor

This tool creates and modifies PLC modules. All editing and creation of PLC data is stored within the PLC Database File (ACE\_PLC.MDB).

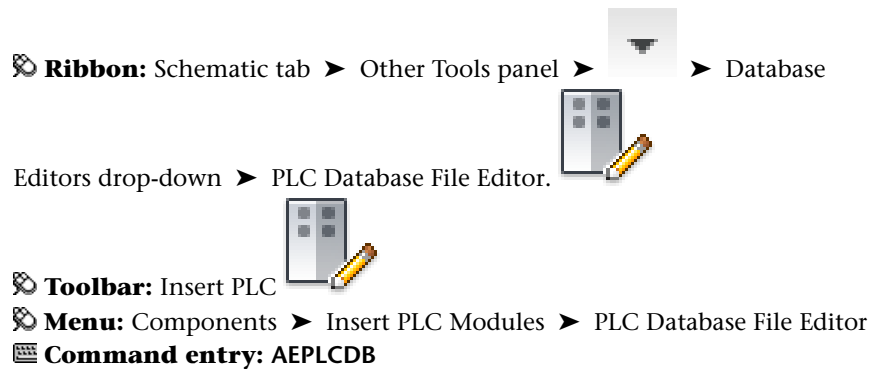

### PLC Selection List

Provides a complete list of the PLC data files available to AutoCAD Electrical. The PLC Selection list uses an expandable and collapsible tree structure for the PLC categories. These PLC categories are: Manufacturer, Series, Type, and Part Number. The tree structure supports right-click controls for copying, renaming, deleting, and creating PLC data.

The right-click controls for the selection list are:

#### New Manufacturer

(available only for the PLC branch of the tree structure) Defines a new manufacturer. The manufacturer then appears in the PLC Selection tree structure in alphabetical order.

<b>New Series</b>	(available only for the Manufacturer branch of the tree structure) Defines a new PLC series underneath the respective Manufacturer. The series then appears in the PLC Selection tree structure in alphabetical order.
<b>New Type</b>	(available only for the Series branch of the tree structure) Defines a new PLC type underneath the respective Manufacturer and Series. The type then appears in the PLC Selection tree structure in alphabetical order.
<b>New Module</b>	(available only for the Type and Module/Code branches of the tree structure) Defines a new PLC module underneath the respective Manufacturer, Series, and Type. The module then appears in the PLC Selection tree structure in alphabetical order.
<b>Paste Module</b>	(available only for the Type branch of the tree structure) Copies the PLC module to the highlighted PLC Type branch. This option becomes active after you copy or cut a PLC module inside the Module/Code branch of the tree structure.
<b>Delete</b>	Deletes an entire PLC module, type, series, or manufacturer from the tree structure and the PLC database (ACE_PLC.MDB).
<b>Rename</b>	Renames a PLC module, type, series, or manufacturer in the tree structure. You cannot have duplicate names in the same branch of the tree structure.
<b>Cut</b>	(available only for the Module branch of the tree structure) Cuts the highlighted module code from the tree structure. You can then paste the code into the same PLC Type, or a new PLC Type category.
<b>Copy</b>	(available only for the Module branch of the tree structure) Copies the highlighted module code from the tree structure into the same PLC Type, or a new PLC Type.

---

**NOTE** If you attempt to copy a PLC Module part number into a PLC Type that already has a module with the same name, the PLC Database File Editor prompts you to change the name of the new module being copied.

---

### **Terminal Grid Control**

Highlight a module from the PLC Selection tree structure to populate the Terminal Grid Control with the terminal information that was previously



defined for the module. When creating a PLC module, the PLC Database File Editor lists as many blank Terminal Type fields since terminals defined within the New Module dialog box.

<b>Terminal Type</b>	Specifies the type for the terminal. Select from the various predetermined types of addressable terminals and non-addressable terminals.
<b>Show</b>	Shows terminals that are not used. If Include Unused/Extra Connections in the Module Layout dialog box is selected, all terminal entries marked (in the PLC Database File Editor dialog box) with 'when excluding unused' are skipped and all terminal entries marked with "when including unused" are shown.
<b>Optional Re-prompt</b>	Prompts for a new beginning address number when the parametric build flips from inputs to outputs or from outputs to inputs. On the line where you want AutoCAD Electrical to prompt for a new output address, select Output. If you want AutoCAD Electrical to prompt for a new input address, select Input from the list.
<b>Break After</b>	Specifies for the module to break automatically after a specific terminal type. To activate the prompt for an automatic break in the PLC module, select Break After.
<b>Spacing Factor</b>	Overrides the current rung spacing for I/O and wire connection point spacing. For example, a value of two inserts the point down two times the rung spacing instead of a full rung spacing.

You can right-click any row in the grid control to activate a menu of commands that allows you to edit the terminal, insert a new terminal before or after the selected terminal in the grid control, or delete a terminal from the grid control. You can select multiple fields to update at the same time by dragging your mouse across contiguous fields or by holding down the Control key while selecting non-contiguous fields.

### **Terminal Attributes**

Displays attributes associated to the selected terminal. These attributes can have predefined values, including some values that you specify at insertion time.

### **New Module**

Opens a dialog box for defining the module descriptions and parameters. A series of boxes are used to type in or select the values required to define the module.

---

**NOTE** If you right-click a type or module in the PLC Selection window and select New Module, the New Module dialog box opens with data already specified for the Manufacturer, Series, and Series Type.

---

### **Module Specifications**

Opens a dialog box for modifying some of the specifications previously defined during the creation of a new module.

---

**NOTE** The Manufacturer, Series, Series Type, Code, and Terminals fields are not active since they are under the control of the tree structure in the PLC Selection window and the total number of terminals listed in the Terminal Type grid control.

---

### **Save Module**

Saves the module to the PLC database file. If you exit the PLC Database File Editor without clicking Save Module, you get a prompt asking whether to save your changes.

### **Style Box Dimensions**

Opens a dialog box for defining the module box dimensions (such as the offset values and line properties) based upon the style number used when the PLC was created.

---

**NOTE** The Module Box Dimensions override the style dimensions.

---

### **Settings**

Opens a dialog box for adding or updating the symbols available to build a module.

### **PLC selection**

Selects a module to add to the terminal blocks from. Select the module from the list and click OK.

 **Ribbon:** Schematic tab > Other Tools panel >  > Database

Editors drop-down > PLC Database File Editor.

 **Toolbar:** Insert PLC

 **Menu:** Components > Insert PLC Modules > PLC Database File Editor



 **Command entry:** AEPLCDB

Click the Settings button, then click the Add Blocks From Module button.

The dialog box provides a complete list of the PLC modules available to AutoCAD Electrical. The Manufacturer Catalog list is compiled from the "ace\_plc.mdb" file.

## Module box dimensions

Defines the outer box dimensions of the module. The box dimensions are calculated from the insertion point of the parametrically built PLC symbols.

 **Ribbon:** Schematic tab > Other Tools panel >  > Database

Editors drop-down > PLC Database File Editor.

 **Toolbar:** Insert PLC

 **Menu:** Components > Insert PLC Modules > PLC Database File Editor

 **Command entry:** AEPLCDB

Click the New Module or Module Specifications button, and then click the Module Box Dimensions button.

---

**NOTE** A value for the Split Top and Split Bottom dimensions must be set before you can specify their line properties.

---

## Module Box Dimensions

**NOTE** Enter at least one of the Top, Bottom, Left or Right dimension values to assign settings specific to this module.

Sets the right, left, top, and bottom offsets for the rectangle that surrounds the module. The optional Split Top and Split Bottom specify the offsets for a split module where Split Top specifies the offset for the top of a split module and Split Bottom specifies the offset for the bottom of the split module. If left blank, AutoCAD Electrical uses the rectangle Top and Bottom values.

## Line Properties

Sets the properties for the lines that make up the box. You can set the color and linetype using the properties fields. To predefine the color, enter "COLOR colorname" into the box. For linetype, enter "LTYPE linetypename" into the box. See the CHPROP command in the AutoCAD Help for more information about the various properties you can set.

If you do not want the line drawn, enter the keyword "ERASE" or "\_E". If you want to apply some special procedure to the drawn line, for example, break the line across terminal graphics, you can reference your custom AutoLISP function in this box. Within your function use "(entlast)" to reference the drawn line entity.

## Select terminal information

Adds or modifies the type of terminal being used. You can select multiple fields to edit at the same time by dragging your mouse across contiguous fields or by holding down the Control key while selecting non-contiguous fields.

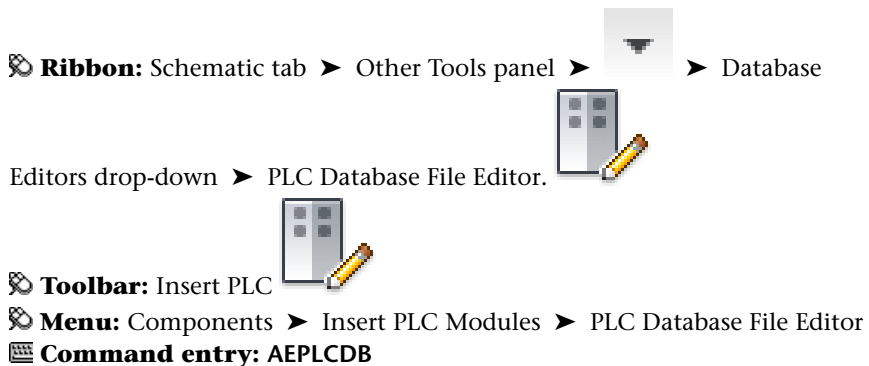

Right-click in the terminal grid control section of the dialog box, and select Edit Terminal from the menu.

The dialog box options enable depending on the fields selected at the time the dialog box was activated. For example, if you select the Show and Spacing Factor fields for multiple terminal entries in the Terminal Grid Control section of the PLC Database File Editor dialog box and then you activate this dialog box, you can update both fields through this dialog box for the selected terminals.

### **Category**

Lists the terminal categories to select from. Top Input and Top Output are addressable terminals, while the Top Terminal category consists of non-addressable terminals. Other categories to select from are Input, Output, and Terminal.

### **Types for Category**

Displays the types for the terminal category. Browse the list of images to determine which terminal type is appropriate for the terminal.

### **Recently Used**

Shows an image of the terminals that were recently used.

### **Show**

Specifies whether to show terminals that are not used. If the 'Include unused/extra connections' option in the Module Layout dialog box is selected, all terminal entries marked (in the PLC Database File Editor dialog box) with 'when excluding unused' are skipped.

### **Optional Re-prompt Address**

Specifies whether to prompt for a new beginning address number when the parametric build flips from inputs to outputs or from outputs to inputs. On the line where you want AutoCAD Electrical to reprompt for a new output address, select Output. If you want AutoCAD Electrical to reprompt for a new input address, select Input from the list.

### **Break After**

Specifies for the module to break automatically after a specific terminal type. To activate the prompt for an automatic break in the PLC module, check the Break After check box.

## Spacing Factor

Overrides the current rung spacing for I/O and wire connection point spacing. For example, a value of 2 causes AutoCAD Electrical to insert the point down two times the rung spacing instead of a full rung spacing.

## New module

Defines the module descriptions and parameters. A series of boxes are used to type in or select the values required to define the module.

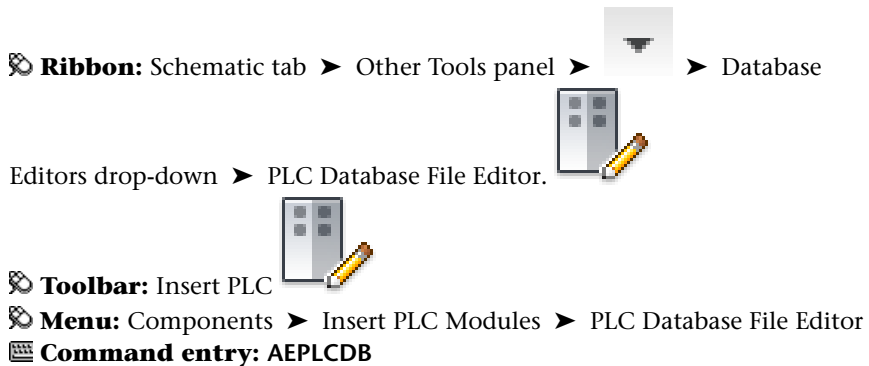

Click New Module.

## New Module Controls

Specifies the Manufacturer, Series, Series Type, and Code (Catalog Number) for the new module. Select from the list or enter the name in the edit box.

**NOTE** If you right-click a type or module in the PLC Selection window and select New Module, the New Module dialog box opens with data already specified for the Manufacturer, Series, and Series Type.

## PLC Selection Expanded Description Listing Controls

These controls display as an expanded description when the module is highlighted in the tree structure of the PLC Selection dialog box. They include:

<b>Description</b>	Describes the PLC module being defined.
<b>Module Type</b>	Gives an abbreviated type to the PLC module.
<b>Base Addressing</b>	Specifies whether the PLC module addressing follows an industry standard. Select from Octal, Decimal, Hexadecimal, and Prompt.

	Prompt asks you at module insertion time for Octal, Decimal, and Hexadecimal.
<b>Rating</b>	Specifies the power rating value for the PLC module.
<b>Terminals</b>	Specifies the total number of terminals defined on the PLC module.
	<hr/> <b>NOTE</b> It is not active since it is under the control of the total number of terminals listed in the Terminal Type grid control. <hr/>
<b>Addressable Points</b>	Specifies the total number of termination points on the PLC module that receives the PLC address attributes.

### **AutoCAD Block to insert**

Specifies an AutoCAD block file to insert directly below the last I/O point inserted parametrically. They are typically used for block files that represent DIP switch settings and notes on how to configure the PLC module.

### **AutoLISP file to run at module insertion time**

Specifies an AutoCAD Lisp routine to run after the program executes the parametric build of the PLC module. They are typically used for inserting groups of symbols and wires, or modifying attributes on symbols to accommodate a more custom PLC module build.

### **Module Box Dimensions**



Opens a dialog box for defining the outer box dimensions of the module. The box dimensions are calculated from the insertion point of the parametrically built PLC symbols.

### **Module Prompts**

Opens a dialog box for defining up to nine prompts to use at the time of module insertion. You can specify the prompt number and the accompanying text, or you can remove prompts from this dialog box.

### **Terminal block settings**

Adds or updates the symbols available to build a module.

 **Ribbon:** Schematic tab > Other Tools panel >  > Database

Editors drop-down > PLC Database File Editor. 

 **Toolbar:** Insert PLC 

 **Menu:** Components > Insert PLC Modules > PLC Database File Editor

 **Command entry:** AEPLCDB

Click Settings.

You can add a terminal to the list by clicking in any box in the last entry of the list. A blank entry line is added to the bottom of the list. Define the block name, assign it to a terminal category for selection, give it a description, and assign a bitmap to uses for dialog box displays.

### **Block File Name**

Defines the AutoCAD drawing file name that is inserted if this terminal is included in your PLC module. These PLC symbols are stored in the symbol library of the active project with the other AutoCAD Electrical component symbols. Their file names begin with the characters "HP" (Horizontal ladder rungs/PLC) or "VP" (Vertical ladder rungs/PLC) followed by a digit that corresponds to a PLC I/O style number.

### **Category**

Defines the category for the terminal. When you add a new terminal, you select from a list of terminal categories and that group of terminals is displayed. There are some categories by default (such as Input or Output) but you can add your own by typing in the edit box. This new category is added to the list.

### **Unique Description**

Specifies the description that appears underneath the terminal in the Select Terminal Information dialog box.

### **Sample Bitmap File**

Specifies the bitmap file for the terminal type. They are visible on the Select Terminal Information dialog box. If you are adding your own terminals, you



can create corresponding bitmap files. Enter your bitmap name in the box or Browse for it. The next time you select a terminal type, the bitmap is displayed.

### Graphics Style

Specifies the graphical appearance of the PLC module. Styles 1-5 are predefined, styles 6-9 may be user-defined. Select a style number - a sample portion of a PLC module displays.

There are about two dozen symbols (with a file name "HP?\* .dwg" where "?" is the style number) associated with each style. They are located in

- **Windows XP:** \Documents and Settings\All Users\Documents\Autodesk\Acade {version}\libs\{library}\
- **Windows Vista, Windows 7:** \Users\Public\Documents\Autodesk\Acade {version}\libs\{library}\

To create a style, copy symbols of an existing style to one of the unused style numbers (6-9) and edit each library symbol.

### View Drawing or View Bitmap

Displays the AutoCAD .dwg or bitmap file for the selected terminal. You can see the attributes of a specific terminal and the placement of each.

### Add Blocks From Module

Opens a dialog box for selecting a module to add terminal blocks from. Select the module from the list and click OK.

### Style box dimensions

Defines the module box dimensions (such as the offset values and line properties) based upon the style number used when the PLC was created.

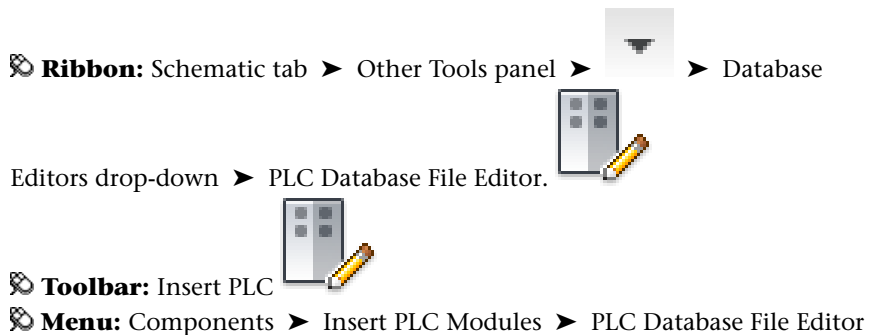

### **Command entry: AEPLCDB**

Click Style Box Dimensions.

---

**NOTE** Set a value for the Split Top and Split Bottom dimensions before specifying their line properties.

---

### **Graphics Style**

Specifies the graphical appearance of the PLC module. Styles 1-5 are predefined, styles 6-9 may be user defined. Select a style number - a sample portion of a PLC module displays.

There are about two dozen symbols (with a file name "HP?\*.\*.dwg" where "?" is the style number) associated with each style. They are located in

- **Windows XP:** \Documents and Settings\All Users\Documents\Autodesk\Acade {version}\libs\{library}\
- **Windows Vista, Windows 7:** \Users\Public\Documents\Autodesk\Acade {version}\libs\{library}\

To create a style, copy symbols of an existing to one of the unused style numbers (6-9) and edit each library symbol.

### **Module Box Dimensions for Selected Style**



Sets the right, left, top, and bottom offsets for the rectangle that surrounds the module. The optional Split Top and Split Bottom specify the offsets for a split module where Split Top specifies the offset for the top of a split module and Split Bottom specifies the offset for the bottom of the split module. If left blank, the rectangle Top and Bottom values are used.

### **Line Properties**

Sets the properties for the lines that make up the box. You can set the color and linetype using the properties fields. To predefine the color, enter "COLOR colorname" into the box. For linetype, enter "LTYPE linetypename" in the box.

### **Module specifications**

Modifies specifications previously defined during the creation of a new module.

 **Ribbon:** Schematic tab > Other Tools panel >  > Database

Editors drop-down > PLC Database File Editor.

 **Toolbar:** Insert PLC

 **Menu:** Components > Insert PLC Modules > PLC Database File Editor

 **Command entry:** AEPLCDB

Click Module Specifications.

### Module Controls

Specifies the Manufacturer, Series, Series Type, and Code (Catalog Number) for the module.

---

**NOTE** These fields are not active since they are under the control of the tree structure in the PLC Selection window.

---

### PLC Selection Expanded Description Listing Controls

These controls display as an expanded description when the module is highlighted in the tree structure of the PLC Selection dialog box. They include:

<b>Description</b>	Describes the PLC module being defined.
<b>Module Type</b>	Gives an abbreviated type to the PLC module.
<b>Base Addressing</b>	Specifies whether the PLC module addressing follows an industry standard. Select from Octal, Decimal, Hexadecimal, and Prompt. Prompt asks you at module insertion time for Octal, Decimal, and Hexadecimal.
<b>Rating</b>	Specifies the power rating value for the PLC module.
<b>Terminals</b>	Specifies the total number of terminals defined on the PLC module.

---

**NOTE** It is not active since it is under the control of the total number of terminals listed in the Terminal Type grid control.

---

**Addressable Points**

Specifies the total number of termination points on the PLC module that receives the PLC address attributes.

**AutoCAD Block to insert**

Specifies an AutoCAD block file to insert directly below the last I/O point inserted parametrically. They are typically used for block files that represent DIP switch settings and notes on how to configure the PLC module.

**AutoLISP file to run at module insertion time**

Specifies an AutoCAD Lisp routine to run after the program executes the parametric build of the PLC module. They are typically used for inserting groups of symbols and wires, or modifying attributes on symbols to accommodate a more custom PLC module build.

**Spreadsheet to PLC I/O Utility Insertion Position**

Specifies the insertion position for this module when inserted during the Spreadsheet to PLC I/O utility. Select from the list of options, Center, Left/Top, or Right/Bottom.

- **Center** - inserted centered between the bus lines of the ladder.
- **Left/Top** - inserted near the left or top bus line of the ladder.
- **Right/Bottom** - inserted near the right or bottom bus line of the ladder.

**Module Box Dimensions**

Opens a dialog box for defining the outer box dimensions of the module. The box dimensions are calculated from the insertion point of the parametrically built PLC symbols.

**Module Prompts**

Opens a dialog box for defining up to nine prompts to use at the time of module insertion. You can specify the prompt number and the accompanying text, or you can remove prompts from this dialog box.

**Prompts at module insertion time**

Defines up to nine prompts to use at the time of module insertion. You can specify the prompt number and the accompanying text, or you can remove prompts from this dialog box.

 **Ribbon:** Schematic tab > Other Tools panel >  > Database

Editors drop-down > PLC Database File Editor.

 **Toolbar:** Insert PLC

 **Menu:** Components > Insert PLC Modules > PLC Database File Editor

 **Command entry:** AEPLCDB

Click the New Module or Module Specifications button, then click the Module Prompts button.

You can define up to nine different prompts at insertion time.

- To assign a prompt, select the prompt number from the list, enter the prompt text in the edit box, and click Change.
- To modify a prompt, select the prompt number from the list, modify the text in the edit box, and click Change.
- To remove a prompt, select the prompt number from the list and click the Remove Selected Prompt button.

### Example

If you assigned RACK NUMBER to the prompt %%1 and SLOT NUMBER to the prompt %%2. At insertion time, the I/O Point dialog box opens. Enter values for the RACK NUMBER and SLOT NUMBER fields right before the module is built. The value you enter in the RACK NUMBER edit box is temporarily saved in memory under the variable name %%1. The SLOT NUMBER value is saved under the %%2 variable name.

Use these prompts in the attribute grid to fill in attribute values or partial attribute values at module insertion time.

### PLC Database Migration Utility

The Spreadsheet to PLC/IO utility uses the module category to calculate the insertion point of a module.

- **Input module** - inserted near the right or bottom bus line of the ladder.
- **Output module** - inserted near the left or top bus line of the ladder.

- **Combination module** - inserted centered between the bus lines of the ladder.

Before AutoCAD Electrical 2009, the Spreadsheet to PLC/IO utility determined the module category based on the value in the DESCRIPTION field or the database table name. For example, if the DESCRIPTION field contained the string “\*IN\*”, it was considered an input module. In AutoCAD Electrical 2009 and later, the PLC database contains a CATEGORY field.

### PLC Database Migration Utility

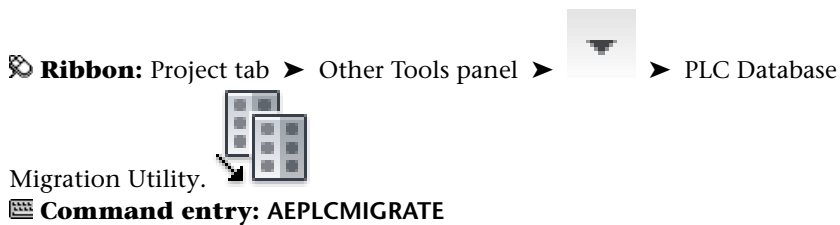

### PLC Database File Editor

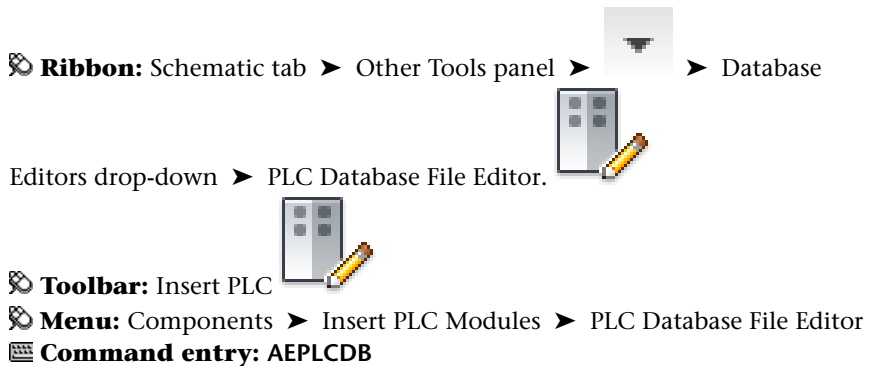

When you use the PLC Database Editor, if the CATEGORY field is not present in the table for the selected series type, you are prompted to run the PLC Database Migration utility.

The PLC Database Migration utility compares the values in the DESCRIPTION field of the PLC database to values you assign as input, output, or combination. If a match is not made, the database table name is compared. If there is a match to the DESCRIPTION field or table name, the CATEGORY value is entered for that module.

- 1 - Input module

- 2 - Output module
- 3 - Combination module

<b>Input</b>	Enter text, comma delimited, used to match to the DESCRIPTION value. If there is a match, the module is assigned a CATEGORY value of 1 for input.
<b>Output</b>	Enter text, comma delimited, used to match to the DESCRIPTION value. If there is a match, the module is assigned a CATEGORY value of 2 for output.
<b>Combination</b>	Enter text, comma delimited, used to match to the DESCRIPTION value. If there is a match, the module is assigned a CATEGORY value of 3 for combination.
<b>Overwrite existing settings</b>	Select to overwrite any existing CATEGORY values. If not selected, only blank CATEGORY fields are modified.

The PLC Database Migration utility updates all tables in the PLC database based on these values.

---

**NOTE** Blank spaces within the text are included as part of the search string. For example, "IN{space}\*" matches "IN module" but does not match "INPUT".

---

If no match is made for a module, the CATEGORY field is not modified. Use the PLC Database File Editor to assign a category to a module. Select a "Spreadsheet to PLC I/O Utility Insertion Point" option on the [Module specifications](#) on page 614 dialog box.

### How to re-run the PLC Database Migration Utility

If you do not get the desired results you can run this utility again.

- 1 Using Microsoft Access, open the PLC database file ace\_plc.mdb.
- 2 Open the table for the series type.
- 3 Remove the CATEGORY field from the table.
- 4 Save the database file.
- 5 In AutoCAD Electrical, run the PLC Database Migration Utility.
- 6 Enter the text strings for each category.
- 7 Click OK.

# Single, Stand-alone I/O Points

## Modify single, stand-alone PLC layout symbols

The single, stand-alone PLC I/O symbols are in

- **Windows XP:** \Documents and Settings\All Users\Documents\Autodesk\Acade {version}\libs\{library}\
- **Windows Vista, Windows 7:** \Users\Public\Documents\Autodesk\Acade {version}\libs\{library}\

The symbols do not follow the normal AutoCAD Electrical naming convention. Their file names must start with "PLCIO" in order for AutoCAD Electrical to find and process them along with the full PLC modules in the various BOM and PLC reports. The last three characters need not follow any naming convention.

Open each in AutoCAD and modify the appearance to suit your needs. Here are the file names of the default symbols:

PLCIO1T.dwg	First input, single wire left
PLCIO1.dwg	2+ input, single wire left
PLCIO2T.dwg	First input, wire left, and right
PLCIO2.dwg	2+ input, wire left, and right
PLCIO01T.dwg	First output, wire right
PLCIO01.dwg	2+ output, wire right
PLCIO02T.dwg	First output, wire left, and right
PLCIO02.dwg	2+ output, wire left, and right

## Insert PLC layout points

PLC I/O points can be inserted as independent symbols spread out over your drawing set. AutoCAD Electrical provides a small set of single I/O point library symbols that you can expand and modify to suit your needs.



- 1 Click Schematic tab ► Insert Components panel ► Insert Components



- 2 On the main icon menu select PLC I/O.

---

**NOTE** Single I/O points are selected from the second and third rows of the sub dialog box.

---

- 3 Select the component to insert and specify an insertion point.

---

**NOTE** Select from the upper row for the first I/O point of a module. These symbols carry attributes for catalog BOM assignment. Select from the bottom row for the second through nth points of a module (which are children symbols of the first symbol parent).

---

- 4 Add or edit any information in the Edit PLC I/O Point dialog box and click OK.

## Annotate stand-alone I/O points

The Edit PLC I/O Point dialog box appears when a stand-alone I/O point symbol is inserted or edited. Use this dialog box to change your selected I/O point.

- 1 Click Schematic tab ► Insert Components panel ► Insert Components



- 2 Select to insert PLC I/O points (found on the second and third rows of the sub dialog box) and specify an insertion point.

To edit a point, right-click on an I/O point and select Edit Component from the context menu.

- 3 Change the I/O point.
- 4 (Optional) To assign the I/O address, click Used: Drawing or Used: Project to select an I/O address that was used already on a module.
- 5 (Optional) To assign the description, click External File to select the description from a comma-delimited ASCII text file of available I/O point descriptions.

6 Click OK and the values are annotated onto the I/O point.

## Edit PLC I/O point

Use this dialog box when inserting or editing a stand-alone I/O point symbol. Specify the values you need and press OK. The values are then annotated onto the selected I/O point.

 **Ribbon:** Schematic tab ► Insert Components panel ► Insert

Components drop-down ► Icon Menu.



 **Toolbar:** Main Electrical

 **Menu:** Components ► Insert Component

 **Command entry:** AECOMPONENT



Select to insert a PLC I/O point. Specify the insertion point on the drawing.

### Address

<b>I/O Address</b>	Searches for a wire connection to a nearby PLC I/O address and, if found, uses the PLC address number in the tag name of the component.
<b>Used: Drawing or Project</b>	Lists any I/O addresses already assigned. Select a tag from the list to copy, or to increment for this new component.
<b>Parent/Sibling</b>	Transfers all information from the parent component to the child component being inserted or edited. If the parent is visible on the screen, click Parent/Sibling, and select the parent (or another related contact).

### Module Tag/Description

<b>Tag</b>	Specifies a unique identifier assigned to each I/O point. The tag value can be manually typed in the edit box.
<b>Line1/ Line2</b>	Optional description text for the I/O point. May be used to identify the relative location of the point in the I/O assembly (for example, Rack # and Slot #).

<b>Manufacturer</b>	Lists the manufacturer number for the I/O point. Enter a value or select one from the Catalog lookup.
<b>Catalog</b>	Lists the catalog number for the I/O point. Enter a value or select one from the Catalog lookup.
<b>Assembly</b>	Lists the assembly code for the I/O point. The Assembly code is used to link multiple part numbers together.
<b>Catalog Lookup</b>	<p>Opens the Catalog Information dialog box from which you can:</p> <ul style="list-style-type: none"> <li>■ Manually enter the Manufacturer or Catalog values.</li> <li>■ Search the database for a specific catalog item to assign.</li> <li>■ Search the drawing or project for a specific catalog item to assign.</li> <li>■ Assign an item number.</li> </ul>
<b>Options</b>	Substitutes a fixed text string for the %F part of the tag format. Retag Component can then use this override format value to calculate a new tag for the PLC module. For example, a certain PLC module must always have an "IO" family tag value instead of "PLC" so that retag, for example, assigns IO-100 instead of PLC100. To achieve this tag override, enter "IO-%N" for the tag override format.
<b>Description</b>	Optional line of description text. May be used to identify the PLC type (for example, "16 Discrete Inputs - 24VDC")

### I/O Point Description

<b>Description 1-5</b>	Specifies optional description text. Enter up to five lines of description attribute text.
<b>Pick</b>	Selects a description from a module on the current drawing.
<b>List descriptions: External file</b>	Displays contents of an external comma-delimited ASCII text file of I/O point descriptions. Pick an entry in the file, and then copy the values to edit boxes in the Edit dialog box.

### **Installation/Location codes**

Changes the installation or location codes. You can search the current drawing or entire project for installation and location codes. A quick read of all the current or selected drawing files is done and a list of codes used so far is returned. Select from the list to update the module automatically with the installation or location code.

### **Pins**

Assigns pin numbers to the pins that are physically located on the module. Assigns terminal description text to available TERMDESC\* attributes. Click List to select from a list of pins associated with the assigned catalog.

### **Show/Edit Miscellaneous**

View or edit any attributes that are not predefined AutoCAD Electrical attributes.

### **Ratings**

Specifies values for each ratings attribute. You can enter up to 12 ratings attributes on a module. Select Defaults to display a list of default values.

---

**NOTE** If Ratings is unavailable, the module you are editing does not carry rating attributes.

---

## **Work with PLC styles**

### **Modify a PLC appearance style**

There are 5 predefined PLC styles provided with AutoCAD Electrical, numbered 1 through 5. If one or more of these do not appeal to you or if you have a client with specific requirements not met by any of the 5 styles, you can pick one of the existing styles and modify it.

There are about 3 dozen symbols associated with each style. They are located in the jic1 subdirectory (or jic125 for the uniform 0.125 text height version). They carry the file name "HP?.dwg" where "?" is the style number.

### **Create a PLC style**

An easy way to create a PLC style is to copy the library symbols of an existing PLC style to one of the unused style numbers (6, 7, 8, or 9) and then edit each one to suit your needs.

For example, copy style 1 to style 6 by copying "\\Documents and Settings\\All Users\\Documents\\Autodesk\\Acade {version}\\libs\\{library}\\hp1\*.dwg" to "\\Documents and Settings\\All Users\\Documents\\Autodesk\\Acade {version}\\libs\\{library}\\hp6\*.dwg" (or, if you are using Windows Vista or Windows 7, copy "\\Users\\Public\\Documents\\Autodesk\\Acade {version}\\libs\\{library}\\hp1\*.dwg" to "\\Users\\Public\\Documents\\Autodesk\\Acade {version}\\libs\\{library}\\hp6\*.dwg"). Open the hp6\*.dwg drawing files in AutoCAD and modify as required. To access your new style, select "6" in the style sub dialog box when you prepare to select and insert a new PLC module.

### Add a new PLC style

The icon menu graphics that display for the various PLC styles are bitmap files saved to your \\Program Files [(x86)]\\Autodesk\\Acade {version}\\Acade\\ folder where AutoCAD Electrical's Insert PLC and Drawing Properties tools can access them.

- 1 Create the style in AutoCAD.
- 2 Zoom in to the new PLC style.
- 3 Save the file as a bitmap using the following name definition:
  - For the Drawing Properties dialog box: the graphic must have the name P\_STYLExH.bmp or P\_STYLExV.bmp where 'x' is the PLC style number (1-9) and H or V indicate the module orientation (horizontal or vertical)
  - For the Insert PLC dialog box: the file name must be STYLExH.bmp or STYLExV.bmp where 'x' is the PLC style number (1-9) and H or V indicate the module orientation (horizontal or vertical)

---

**NOTE** If the resulting bitmap is too small or off-center, open the source drawing in AutoCAD again. Resize your AutoCAD graphics window so that it is more square. Center the image and resave. Repeat until you are satisfied with the result.

---

# Create PLC I/O Drawings from Spreadsheets

## Overview of the PLC spreadsheet/database format

The PLC information can be read from a Microsoft Excel spreadsheet, Access database table, or a comma-delimited file. AutoCAD Electrical expects to find certain columns containing the information needed to generate the drawings. The columns can be in any order defined by your settings. All columns are optional except the Module part number (Code) column. Three example PLC data files are found in the User folder: DEMOPLC.XLS, DEMOPLC.CSV, and DEMOPLC\_IEC.XLS. A settings file is also provided to run the Spreadsheet to PLC I/O Utility: DEMOPLC\_IEC.WDI.

Use the Spreadsheet to PLC I/O Utility tool to assign spreadsheet or table column numbers to the following data categories.

### Module data

<b>Module part numbers (Code)</b>	This can be the code for a parametrically generated module, or for a full module's library symbol. It can even be a non-PLC symbol such as a variable speed drive.
<b>Address (ADDR)</b>	The I/O address for each I/O point. This value gets annotated to the "TAGA_" attribute.
<b>Rack numbers (R)</b>	The rack number of the module, used for the attribute assigned to the %%1 Prompt from the parametric data file.
<b>Group numbers (G)</b>	The group number of the module, used for the attribute assigned to the %%2 Prompt from the parametric data file.
<b>Slot numbers</b>	The slot number of the module, used for the attribute assigned to the %%3 Prompt from the parametric data file.
<b>Remote terminal panel (RTP)</b>	The remote terminal panel ID number of the module, used for the attribute assigned to the %%4 Prompt from the parametric data file.
<b>Wire numbers</b>	The wire number used for each I/O point.
<b>Module's tag</b>	The value assigned to the TAG attribute of the module.

<b>Module's Installation</b>	The value assigned to the installation attribute of the module.
<b>Module's Location</b>	The value assigned to the location attribute of the module.
<b>Description 1-5 (DESC1-DESC5)</b>	The values assigned to the module's 5 description attributes.
<b>Voltage/Input/Output (VOLTAGE)</b>	The value used to determine if a module is an input or output module if it cannot be determined from the parametric data file. For input modules, AutoCAD Electrical looks for DI, AI, or IN as part of the text string. For output modules, AutoCAD Electrical looks for DO, AO, or OUT as part of the text string. For combination modules, it looks for IO, Other, or both IN and OUT in the text string.

### Special PLC values

There are some special values that can be placed in a row to direct special PLC module features:

<b>BREAK</b>	Insert this keyword in the ADDRESS column of the spreadsheet where you want the PLC module to break and continue on the next ladder column. There should not be any other data in the spreadsheet row; only the word "BREAK" in the address column.
<b>SPACER</b>	Insert this keyword in the ADDRESS column of the spreadsheet where you want to add extra space between adjacent I/O points. There should not be any other data in the spreadsheet row; only the word "SPACER" in the address column.
<b>SKIP</b>	Insert this keyword into the CODE module part number column right after the end of the data on the spreadsheet of the previous module. This keyword triggers the utility to skip a ladder before it begins the next module in the spreadsheet. There should not be any other data in the spreadsheet row; only the word "SKIP" in the part number code column.
<b>NEW_DWG</b>	Insert this keyword into the CODE module part number column right after the end of the data on the spreadsheet of the previous module. This keyword triggers the utility to skip to the next sheet before it begins the next module in the spreadsheet. There should not be any other data in the spreadsheet row; only the word "NEW_DWG" in the part number code column.

- \* Place an asterisk (\*) in front of a device block name to trigger an Insert Circuit instead of an Insert Component. Any associated TAG, DESC, MFG, and CAT column values for this entry are annotated onto the first AutoCAD Electrical symbol found on the inserted circuit.

You can predefine other attributes on the module, such as Installation, Location, and Ratings, using the format "mainval;attributename2=attributevalue2," and so on. For example, you want the module to have a Rack value of "2", an Installation value of "MACH1", and a Rating2 value of "Hazardous Duty". In the spreadsheet, in the RACK column, enter "2;INST=MACH1;RATING2=HAZARDOUS DUTY". When the module is generated these extra attribute values are assigned.

### Inline component data

The PLC Generator supports up to 9 inline components. Replace the numeric value "n" with the next incrementing number; the first component would have a tag of D1TAG while the second component would have the tag of D2TAG. The columns of data are as follows:

<b>Tag (DnTAG)</b>	The value to use for the TAG attribute of the component. For terminals, use this column to encode both the TAG and Terminal Number. Use this format TAGSTRIP:TERM where the colon character separates the terminal's TAG-ID value from the terminal number to apply to the TERM attribute. For example, "TB1:25" in the component tag column puts "TB1" on the TAGSTRIP attribute and "25" on the TERM attribute. You can also use the colon delimiter to add pin number assignments to terminal symbols. Whatever follows the colon is inserted into the terminal's TERM01 attribute; in this case, the pin number in your drawing. For example, if the terminal's tag name is "TB1" and the pin number assignment is "1A" you would enter "TB1:1A" into the DnTAG field.
<b>Description (DnDESC)</b>	The values assigned to the DESC attributes of the component. Use the   symbol to separate text and assign it to DESC1, DESC2, or DESC3. For example, if you use "CYCLE START" in the description field, "CYCLE" is assigned to DESC1 and "START" to DESC2.
<b>Block (DnBLK)</b>	The .dwg file name for the component you want to use.
<b>Location (DnLOC)</b>	The value assigned to the location (LOC) attribute of the component.



<b>Installation</b>	The value assigned to the installation (INST) attribute of the component.
<b>Manufacturer</b>	The value assigned to the manufacturer (MFG) attribute of the component.
<b>Catalog</b>	The value assigned to the catalog (CAT) attribute of the component.
<b>Assembly</b>	The value assigned to the assembly code (ASSYCODE) attribute of the component.

You can predefine other attribute values (such as pin number assignments) using the format "mainval;attributename2=attributevalue2;attributename3=attributevalue3," and so on. Enter it in any inline component column except the Block column defining the block name of the component. For example, to annotate pins as "21" and "22", you can modify the DnLOC field by entering "Field; TERM01=21;TERM02=22"; where "Field" is the main attribute value and "TERM01=21" assigns a value of 21 to the component's TERM01 attribute and "TERM02=22" assigns a value of 22 to the component's TERM02 attribute.

Components for input modules are inserted left-to-right, while components for output modules are inserted right-to-left. The spacing between devices (as defined in your settings) is maintained even if no component is defined for a particular column.

### Special wiring for inline components

Normally each inline component is wired in series connected from the bus to the I/O point. AutoCAD Electrical also supports jumpers between adjacent rungs. To direct AutoCAD Electrical to use a jumper, you encode the jumper as one of the available inline devices. Use the "I" character as the symbol block name for the jumper. To control removal of wire connections, follow the "I" character with four characters to cover upper left, upper right, lower left, and lower right connections. Use "W" to keep the wire connection and "X" to remove. For example, a block name of "IWWXW" inserts a jumper and trims the lower left wire connection. "IXWXW" trims away the left-hand wire connections of both top and bottom. Just a "I" for the block name is the same as "IWWWW", all wire connection retained.

Wiring to analog input or output modules might need to loop back to a return terminal instead of going all the way across to a power bus. You can direct the generator to pop in a vertical short wire to loop back around. For looping

back to the right, insert "IXWXW" as the first inline device. To loop back to the left use "IWXXW".

## Automatically generate I/O schematic drawings

The PLC I/O requirements of a project, in spreadsheet or database format, can drive automatic generation of the I/O schematic drawings.

- 1 Click Import/Export Data tab ► Import panel ► PLC I/O Utility.



- 2 Select the spreadsheet and click Open.
- 3 In the Spreadsheet to PLC I/O Utility dialog box, enter a value for the beginning line reference number for the first ladder of the drawing. Specify any other options to use for the ladder reference numbers.
- 4 Specify how you want the module to be placed in the drawing.
- 5 Click Start.

AutoCAD Electrical constructs a set of PLC I/O drawings based on the information carried in the PLC spreadsheet. Ladders and modules insert automatically, breaking at the bottom of one ladder and continuing on the next.

## Change and use PLC I/O settings

You have control over many aspects of how these drawings auto-generate. You also can adapt this tool to an existing spreadsheet or database format that is different from the example demopl.c.xls file format. You can change these settings each time you run the program or change them once and save your settings for future use.

### Change and save the settings

- 1 Click Import/Export Data tab ► Import panel ► PLC I/O Utility.



- 2 Select the spreadsheet and click Open.

- 3 In the Spreadsheet to PLC I/O Utility dialog box, do one of the following:
  - Click Setup to define how the drawings should be set up (based on the default settings). It includes how many ladders you want inserted, the type and orientation of the ladders, spacing, and number of rungs. You can also define the module placement, style, scale, and in-line device placement and spacing.
  - Click Browse to select an existing setting file that you can then edit and save.
  - Click Setup then click Spreadsheet/Table Columns to define what column in your spreadsheet or database table goes with what data value in the utility. The first page of this dialog box deals with the overall module information. The sub-dialog box (accessed from clicking the More button) identifies the column data for up to nine in-line connected devices for each I/O point.
- 4 Click Save to save the settings to a file for future use.
- 5 Enter a file name for the settings (the file extension is ".WDI") and click Save.

### Read the settings

- 1 Click Import/Export Data tab ► Import panel ► PLC I/O Utility.



- 2 Select the spreadsheet and click Open.
- 3 In the Spreadsheet to PLC I/O Utility dialog box, click Browse.
- 4 Select a previously created file (it has a ".WDI" file extension) and click Open.

Your settings are now restored and are used for the drawings generated from the selected spreadsheet or database table.

### Spreadsheet to PLC I/O utility

Creates a set of PLC I/O drawings from spreadsheet data.

 **Ribbon:** Import/Export Data tab ► Import panel ► PLC I/O Utility.



 **Toolbar:** Insert PLC

 **Menu:** Components ► Insert PLC Modules ► Spreadsheet to PLC I/O Utility

 **Command entry:** AESS2PLC

Select the spreadsheet output file and click Open.

The PLC I/O requirements in spreadsheet or database format can drive automatic generation of the I/O schematic drawings. The program finds the columns containing the information necessary to generate the drawings. Your settings can define the order of the columns. All columns are optional except for Module part number (Code).

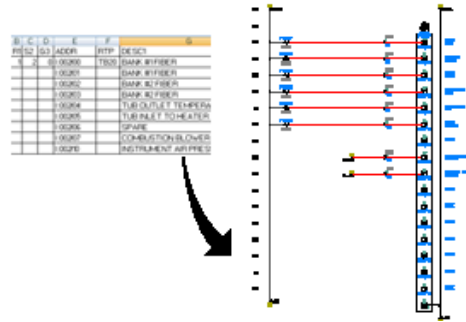

AutoCAD Electrical reads in your information (.xls, .mdb, or .csv format) and then constructs a set of PLC I/O wiring diagrams directly from your data. Ladders and modules insert automatically, breaking at the bottom of one ladder and continuing on the next (or on to the next drawing).

### Settings

Select a PLC settings file (.wdi) to use. The default is to use the settings in the WDIO.LSP file. Specify the settings to use by entering a file name in the box or clicking Browse to select a file. The path to the selected WDI file displays underneath the edit box. If you enter the name of the .wdi file, AutoCAD Electrical searches for the file in the standard search locations in the following order:

- 1 User subdirectory  
**Windows XP:** C:\Documents and Settings\{username}\Application Data\Autodesk\AutoCAD Electrical {version}\{release}\{country code}\Support\User\  
**Windows Vista, Windows 7:**  
C:\Users\{username}\AppData\Roaming\Autodesk\AutoCAD Electrical {version}\{release}\{country code}\Support\User\
- 2 Active project's .wdp file subdirectory
- 3 Symbol library paths defined for the active project
- 4 AutoCAD Electrical lookup subdirectory  
**Windows XP:** C:\Documents and Settings\{username}\My Documents\Acade {version}\AeData\  
**Windows Vista, Windows 7:** C:\Users\{username}\Documents\Acade {version}\AeData\
- 5 AutoCAD Electrical support (C:\Program Files [(x86)]\Autodesk\Acade {version}\Support\.)
- 6 Current Directory
- 7 All paths defined under AutoCAD Options ► Files ► Support Files Search Path

Click Setup to display the Spreadsheet to PLC I/O Utility Setup dialog box. Use it to modify and save new setting configurations.

---

**NOTE** If you select the .wdi file to use after you make changes in the Spreadsheet to PLC I/O Utility Setup dialog box, the settings in the .wdi file are used and the setup changes are not applied.

---

### Ladder Reference Numbering

<b>Start</b>	Specifies the value for the beginning line reference number for the first ladder of the first drawing. Leading zeros and embedded alpha characters are supported for line reference numbering.
<b>Index</b>	Defines if you want your line reference numbers to sequence by 1 (default) or by some other amount.

Column to column	Indicates whether to use the next sequential number for the first ladder on each successive column or to use the specified value to skip for the first ladder reference of the next column.
Drawing to drawing	Indicates whether to use the next sequential number for the first ladder on each successive drawing or to use the specified value to skip for the first ladder reference of the next drawing.

### Module Placement

There are three options related to module placement. Define if you want each I/O module to start at the top of a ladder, if you want the module built in a ladder with the previous module only if it fits completely, or if you want the module to be built in the same ladder with the previous module and split if necessary to fill the ladder.

<b>Include unused/extra connections</b>	<p>You may have PLC modules with terminal connections that are unused. Usually AutoCAD Electrical leaves them out and the module is built without showing these terminal connections. Select it to include the connections in the PLC module.</p> <p>If you select to place modules within the same ladder, enter the number of rungs to skip between modules.</p> <hr/> <p><b>NOTE</b> When a module is selected that contains some of these terminals, they are included if you select this option.</p> <hr/> <p>If you want to show these connections, include them in the Attributes column of the Module Terminal Information table of the ace_plc.mdb file with ";\\SPECIAL=INCLUDE" following the block information or by selecting "When Including Unused" or "When Excluding Unused" in the Show column of the PLC Database File Editor dialog box.</p>
<b>Allow pre-defined breaks</b>	<p>Your PLC modules automatically break at a given point when a "\\SPECIAL=BREAK" code is encountered in the block of parametric data of the module.</p>

## Drawing File Creation

<b>Use active drawing</b>	Indicates to use the open and active drawing file to begin the PLC placement process. <hr/> <b>NOTE</b> It is unavailable if a Starting file name is specified. <hr/>
<b>Starting file name</b>	Specifies the drawing file to begin with for your PLC drawings. Enter a name or click Browse to select a file. The .dwg extension is not required and the file is saved in the same folder as the active .wdp file.
<b>Pause between drawings/Free run</b>	Your spreadsheet may contain enough information to generate multiple drawings. Select Pause between drawings to stop between each drawing or select Free run if you want the program to run completely to the end without stopping. <hr/> <b>NOTE</b> When you select Pause Between Drawings, a single drawing is generated and then a dialog box opens allowing you to adjust settings, select to do a free run, or continue with a pause between drawings. The Use active drawing option is disabled. <hr/>
<b>Sheet</b>	If your ladders use the AutoCAD Electrical Sheet parameter you can enter a value for the optional sheet number.
<b>Add new drawing to active project</b>	Adds newly created drawings to the active project. The new drawings are added to the end of the project's drawing list.

### Save

Saves the setup information and settings in a .wdi file to reuse.

### Spreadsheet to PLC I/O utility setup

Defines how to set up the drawings. Includes how many ladders you want inserted, the type and orientation of the ladders, spacing, and number of rungs. You can also define the module placement, style, scale, and inline device placement and spacing.

 **Ribbon:** Import/Export Data tab ► Import panel ► PLC I/O Utility.



 **Toolbar:** Insert PLC

 **Menu:** Components ► Insert PLC Modules ► Spreadsheet to PLC I/O Utility

 **Command entry:** AESS2PLC

Select the spreadsheet output file and click Open. In the Spreadsheet to PLC I/O Utility dialog box, click Setup.

---

**NOTE** New default values can be programmed into the source file. The program source file name is "wdio.lsp." Open the file with any ASCII text editor and carefully edit the values near the top of the file.

---

## Ladder

<b>Origin</b>	Specifies the insertion point for first (or only) ladder on the drawing. Corresponds to the upper left-hand corner of the ladder.
<b>Orientation</b>	Specifies to create a vertical bus ladder (with horizontal wires) or horizontal bus ladder (with vertical wires).
<b>Reference numbers</b>	Specifies the default referencing system: <ul style="list-style-type: none"><li>■ Numbers Only</li><li>■ Numbers Ruling</li><li>■ User Blocks</li><li>■ X-Y Grid: All referencing is tied to an X-Y grid system of numbers and letters along the left-hand side and top of the drawing. Set the vertical and horizontal index numbers and letters, spacing, and origin in the X-Y grid setup dialog box.</li></ul>

---

**TIP** Use negative spacing values for horizontal or vertical to change the origin of the XY grid system to be other than the upper left-hand corner of the drawing.

---



- X Zones: Like X-Y Grid, but there is not a Y-axis. Set your horizontal labels, spacing, and origin of the drawing on the X Zones setup dialog box.

---

**TIP** Use a negative zone spacing value if you want the zone reference origin to be at the right side of the drawing.

---

<b>Width</b>	Specifies the width of each ladder (offset distance between the ladder's two bus wires) from left to right rail.
<b>Distance between</b>	Specifies the offset distance from the insertion point of one ladder to the insertion point of the next ladder.
<b>Ladders per drawing</b>	Specifies the number of ladders to insert. Vertical ladders insert left to right. Horizontal ladders insert top to bottom.
<b>Rungs per ladder</b>	Specifies the quantity of line reference / wire rungs per ladder. This value multiplied by the "Spacing - ladder rung to rung" value determines the length of the inserted ladders.
<b>Rung spacing</b>	Specifies the distance from one rung to the next rung on a ladder.
<b>Rung count skip for I/O start</b>	Specifies the quantity of rungs to skip before inserting a PLC module (0=no skip)
<b>Suppression</b>	Indicates whether to include/exclude bus rails and rungs.
<b>Signal arrow style</b>	Specifies the default wire signal arrow style. Select from the four predefined styles or a user-defined style. You can override the default style setting at insertion time.

### **Module**

<b>PLC graphical style</b>	Specifies the default PLC module style. Select from the five predefined styles or a user-defined style.
<b>Input offset from neutral</b>	Specifies the Input module insertion offset distance (vertical ladder orientation - measured in

	+X direction from right-hand vertical bus; horizontal ladder orientation - measured in +Y direction from lower horizontal bus).
<b>Output offset from hot bus</b>	<p>Specifies the Output module insertion offset distance (vertical ladder orientation - measured in -X direction from the left-hand vertical bus; horizontal ladder orientation - measured in the -Y direction from the upper horizontal bus).</p> <hr/> <p><b>NOTE</b> If module type cannot be determined or if it is combination Input and Output, then the module is inserted down the middle of the ladder.</p> <hr/>
<b>Maximum I/O per ladder</b>	Specifies the maximum number of module I/O points to insert into each ladder without breaking the module and continuing it in the next ladder.
<b>I/O point spacing</b>	Specifies the insertion point offset distance between one in-line device and the next.
<b>Scale</b>	Specifies the PLC module scale override value (default = 1.0). Applies a scale factor to the PLC module insertion except for the "Spacing - I/O point to I/O point" value defined previously. If Apply this scale to module outline only is selected, then this scaling factor is applied only to the outline of the module.

### In Line Devices

<b>First input device from hot bus</b>	Specifies the starting offset distance from the left-hand or upper bus for the first (or only) in-line device defined for each Input module I/O point.
<b>First output device from neutral bus</b>	Specifies the starting offset distance from the right-hand or lower bus for the first (or only) in-line device defined for each Output module I/O point.

**Spacing between multiple devices**

Specifies the insertion point offset distance between one in-line device and the next.

### **Spreadsheet/Table Columns**

Displays the Spreadsheet to PLC I/O Drawing Generator dialog box for reviewing and mapping spreadsheet columns to attributes on the PLC module symbol.

### **Drawing Template**

You can force the tool to use a specific template for new drawings. Enter the template drawing file name with the full path or click Browse to search for an existing template (it looks in the AutoCAD template folder where all of the user drawing templates are saved). For the current default template, leave the value blank. If you do not want to use a template drawing, enter a single dot in the edit box.

---

**NOTE** Make sure that your template does not have any existing ladders.

---

### **Save**

Saves the spreadsheet information in a .wdi file to reuse. Once you save the new .wdi file, the Spreadsheet to PLC I/O Utility dialog box redisplay and the new .wdi file name displays in the Settings edit box.

## **Create PLC spreadsheets using RSLogix**

RSLogix is a PLC programming software package for programming various Allen-Bradley PLCs. This program has an output function that can write the I/O information out to an ASCII file. AutoCAD Electrical imports this information and creates a regular spreadsheet from the data that can then be used to create PLC drawing files.

Using the RSLogix 500 Import dialog box, you can omit PLC cards, reserve future locations for PLC cards in drawings, and browse to select a PLC code from the PLC database. Once you modify the .eas file and apply the PLC data to categories you can save the data into a PLC import spreadsheet that is used to create the PLC drawing files.

## Export I/O information using RSLogix

Creates a Microsoft Excel spreadsheet file from a RSLogix file to import into AutoCAD Electrical using the Spreadsheet to PLC I/O Utility tool.

- 1 In RSLogix, export your RSLogix 500 file into .EAS format.

- 2 Click Import/Export Data tab ► Import panel ► RSLogix 500.





- 3 Select an .EAS or .CSV file and click Open.
- 4 In the RSLogix 500 Import dialog box, select whether the I/O points should be displayed in 8, 16, or 32-point groupings.
- 5 Pick an I/O module for each set of I/O points. Enter it in the edit box, select from the PLC dialog box using Browse, or select from the already used list once you have some modules selected.
- 6 Click OK to assign the module and move on to the next set of points.
- 7 (Optional) To change a module assignment, select the module assignment and click Change. In the RSLogix 500 Import Change Module dialog box, change the selected module part number by entering the new module name in the edit box, selecting it from the PLC dialog box using Browse, or selecting it from the already used list once you have some modules selected. Click OK to assign the module and return to the Input Module dialog box.
- 8 (Optional) Click Omit to skip a set of points, or click Future to skip the points and add information so AutoCAD Electrical adds a blank column when generating the drawing from the spreadsheet.
- 9 Enter a name for the spreadsheet once a module was assigned for each set of points. Click Save.  
Use Microsoft Excel to modify your spreadsheet as needed.
- 10 To [create the PLC drawing](#) on page 630 click Import/Export Data tab ►



Import panel ► PLC I/O Utility.

## RSLogix 500 import

Imports I/O information from RSLogix and create a regular spreadsheet from the data to use for the Spreadsheet to PLC I/O generator.

 **Ribbon:** Import/Export Data tab ► Import panel ► RSLogix 500. 

 **Toolbar:** Insert PLC

 **Menu:** Components ► Insert PLC Modules ► RSLogix 500 Export To Spreadsheet



 **Command entry:** AERSLOGIX

Select an .EAS or .CSV file and click Open.

The text “Input Module x of x” displays underneath the dialog box title bar to keep track of which module you are editing out of the total number of modules found in the RSLogix import file.

<b>8pt, 16pt, or 32 pt slot addressing</b>	Specifies whether the I/O points displayed should be in 8-pt, 16-pt, or 32-pt groupings.
<b>Default to</b>	Specifies to display the module in octal or decimal format.
<b>Module assignment so far</b>	Displays the I/O modules already picked for each set of I/O points. Enter the module name in the edit box, select it from the PLC dialog box using Browse, or select it from the already used list once you have some modules selected. Click OK to assign the module and move on to the next set of points.
<b>Omit</b>	Skips a set of points.
<b>Future</b>	Skips the points and adds information so AutoCAD Electrical adds a blank column when generating the drawing from the spreadsheet.

## RSLogix 500 import change module

 **Ribbon:** Import/Export Data tab ► Import panel ► RSLogix 500. 



**Toolbar:** Insert PLC

**Menu:** Components ► Insert PLC Modules ► RSLogix 500 Export To Spreadsheet

**Command entry:** AERSLOGIX

Select an .EAS or .CSV file and click Open. Select one of the module assignments and click Change.

The text “Change Module x” displays underneath the dialog box title bar to keep track of which module you are changing.

<b>Select below for module part number assignment</b>	Displays the I/O modules already picked for each set of I/O points. Change the selected module part number by entering the new module name in the edit box, selecting it from the PLC dialog box using Browse, or selecting it from the already used list once you have some modules selected. Select OK to assign the module and return to the RSLogix 500 Import dialog box.
<b>Omit</b>	Skips a set of points.
<b>Future</b>	Skips the points and adds information so AutoCAD Electrical adds a blank column when generating the drawing from the spreadsheet.

## Create PLC drawings from Unity Pro

AutoCAD Electrical imports Unity Pro XML files to aid in the creation of various types of PLC and Panel Layout drawings in the active project. Unity Pro supports numerous Schneider Electrical PLC cards, PLC racks, power supplies, and various accessories.

Unity Pro exports two XML files (.xhw and .xsy) to use in the automatic creation of AutoCAD Electrical PLC ladder-style drawings. The .xhw file contains the PLC hardware information such as catalog numbers and starting addressing information. The .xsy file contains the information about the software such as variable types (input/output) and i/o addressing information.

These files also contain catalog information that can be reformatted to generate an equipment list to help in the creation of a rack layout drawing used in

Panel Layouts or separate Rack Layout drawings using the Unity Pro Export to Spreadsheet tool.

### Data structure from the Unity Pro Hardware Configuration File

The tree structure data that displays in the Hardware File section of the Unity Pro Import dialog box is as follows:

#### Project node

The Project node is the topmost node defined in the tree structure. The label given to the node is the file name of the hardware configuration (.xhw) file that was defined during the export from Unity Pro. The name of the hardware configuration file can be different from that of the I/O configuration file.

#### Bus Name node



The Bus Name node consists of the Bus Name Description and the Bus Number ID.

*Example: Bus 1 Local Quantum Bus*

- Bus Name Description: displays the name of the bus and is specified in the busType element in the .xhw file. (that is, Local Quantum Bus)
- Bus Number ID: displays the number of the bus and is specified in the position element of the .xhw file. (that is, Bus 1)

#### Rack Location and Catalog Number node



The Rack Location node consists of descriptions, location information, and a catalog number.

*Example: Rack \1.1\1 140XBP0600*

- Rack Description: displays the description of the rack and is specified in the family element of the .xhw file. (i.e. Rack)
- Rack Location: displays the location of the rack and is specified in the topoAddress element of the .xhw file. (i.e. \1.1\1)
- Rack Catalog Number: displays the catalog number of the rack and is specified in the partNumber element of the .xhw file. (that is, 140XBP0600)

#### Module Location and Catalog Number node



The Module Location node consists of descriptions, location information, and a catalog number.

*Example: Supply \1.1\1.1 140CPS21400*

- Module Description: displays the description of the module and is specified in the family element of the .xhw file. (that is, Supply)

- **Module Location:** displays the location of the module in the rack and is specified in the topoAddress of the .xhw file. (that is, 1.1\1.1)
- **Module Catalog Number:** displays the catalog number of the module and is specified in the partNumber element of the .xhw file. (that is, 140CPS21400)

### Unity Pro to AutoCAD Electrical Mapping File

The Unity Pro to AutoCAD Electrical mapping file, DEFAULT\_UNITY.MAP, allows you to define the text strings to be placed in the custom field of the Unity Pro Data Editor to map directly to an AutoCAD Electrical schematic symbol name.

#### AutoCAD Electrical Symbol Mapping File Example:

```
;This file is to be used for mapping of Unity Pro custom strings
;for PLC I/O devices to AutoCAD Electrical schematic symbol names
;Syntax: Value in Custom Field,Symbol Block File Name
;Example: PBNO,HPB11
; PBNC,HPB12
PB NC,HPB12
*2POS*,HSS112
*3POS*,HSS113
```

The comment fields (marked with ;) at the top of the file are used for information. The custom field supports spaces in the string and wild cards.

---

**NOTE** The distance the remote component is located from the PLC and hot bus rail is determined by the PLC settings file.

---

#### Equipment List Structure and Data

When you click OK on the Unity Pro Import dialog box, a PLC Spreadsheet file is created along with an Equipment List spreadsheet file. The Equipment List file includes all of the catalog information in the .xhw file. The structure of the Equipment List is:

- Column 1 = CATALOG; partNumber variable from the .xhw file
- Column 2 = MANUFACTURER; found in Default\_cat.mdb (PLCIO table)



- Column 3 = ASSYCODE; column defined (left blank)
- Column 4 = TAG; column defined (left blank)
- Column 5 = LOC; column defined (left blank)
- Column 6 = INST; column defined (left blank)
- Column 7 = DESC1; partFamily variable from the .xhw file
- Column 8 = WDBLKNAM; PLCIO

### Import Unity Pro files to a spreadsheet

- 1 In Unity Pro, right-click the configuration file in the project browser and select Export.
- 2 Enter a file name for the .xhw file and click Export.
- 3 Right-click the Variables & FB Instances file in the project browser and select Export.
- 4 Enter a file name for the .xsy file and click Export.

---

**NOTE** We recommend that you export the files into the same location as the AutoCAD project (.wdp) file.

---

If the export was successful, the Unity Pro command window states that the file was exported with 0 errors or warnings.



- 5 Click Import/Export Data tab ➤ Import panel ➤ Unity Pro. 
- 6 Select the Unity Pro hardware configuration file (.xhw) and click Open.
- 7 Select the Unity Pro I/O configuration file (.xsy) and click Open.  
Upon successful validation of the files selected for import, the Unity Pro Import dialog box displays.
- 8 In the Unity Pro Import dialog box, modify the selected files to create a spreadsheet for PLC import. You can right-click on a module or rack in the tree structure and select to include or exclude it from being saved into the spreadsheet file. Do any of the following optional steps:
  - Indicate whether to display only modules in the .xhw file that contains I/O addressing (PLCs).

- Indicate whether to include inner or outer terminals. Select whether to place the terminal symbol names in every row or only the names that have a defined I/O point.
  - In the Hardware File section, select the module to modify. The data relative to the I/O variable file for the selected module displays in the I/O Variable File section of the dialog box. If you select a module that does not have addresses (such as power supplies or CPUs) the grid remains empty.
  - Change the symbol name or device tag for any of the I/O points using the right-click menu options. The Select Symbol option displays the icon menu from which you can select the symbol name.
  - Specify the symbol name to insert for inner and outer terminals in the spreadsheet. The default symbol name is HT0001 (a terminal that maintains the wire number potential, has a tag strip ID and terminal number, and is square). Click the Select from Icon Menu button to select a terminal to use from the icon menu
- 9 Click OK.
  - 10 Specify a file name and location for the PLC spreadsheet file and click Save.
  - 11 Specify a file name and location for the Equipment List file and click Save.
  - 12 To [create the PLC drawing](#) on page 630 click Import/Export Data tab ►

Import panel ► PLC I/O Utility. 

## Unity Pro import

Prepares Unity Pro exported data for the Spreadsheet to PLC I/O utility.

 **Ribbon:** Import/Export Data tab ► Import panel ► Unity Pro. 

 **Toolbar:** Insert PLC 

 **Menu:** Components ► Insert PLC Modules ► Unity Pro Export to Spreadsheet

 **Command entry:** AEUNITYPROSS

Imports Unity Pro hardware (.xhw) and I/O variable (.xsy) files and formats the data into a PLC import spreadsheet in preparation for the Spreadsheet to PLC I/O utility. After you create the spreadsheet file, create PLC style drawing files automatically with the Spreadsheet to PLC I/O utility.

When you click OK, you are prompted to enter a name for the PLC spreadsheet file. You can save this file in .xls (preferred), .mdb or .csv format. Once you enter a name (or accept the default) and click Save, you are then prompted to create an equipment list spreadsheet file. You can save this file in .xls, .mdb (preferred) or .csv format. The suggested file name is the name of the hardware import file with the suffix '(Equipment).'

### Hardware File

The path and file name of the hardware file created from Unity Pro (.xhw) displays at the top of this section of the dialog box.

#### Hardware file information

Allows you to view and select the hardware configuration from the Unity Pro export files. The tree structure has four nodes:

- Unity Project (export file name)
- Bus name
- Rack location and catalog number
- Module location and catalog number

Right-click on a node to include or exclude modules from being saved into the spreadsheet file. Upon exclusion the module icon changes to indicate that it was excluded. You can exclude or include an entire rack node. Multiple node selection is allowed.

#### Changed icons:



---

**NOTE** If you choose to include modules that do not contain any I/O addressing, the module catalog number appears in the Code column of the spreadsheet.

---

<b>Show only I/O modules</b>	Indicates to display only modules in the .xhw file that contains I/O addressing (PLCs). If a rack node only includes modules that are not PLC I/O modules, the entire rack is removed from the tree structure. If a rack node contains modules with and without I/O addressing, the modules that do not have I/O addresses are removed.
<b>Include inner terminals</b>	<p>Defines a terminal symbol to place into the spreadsheet on the inner side of the in-line component (between the I/O point and the in-line component).</p> <ul style="list-style-type: none"> <li>■ All I/O addresses: Places the terminal symbol name into the row of every I/O address listed in the import spreadsheet.</li> <li>■ I/O addresses defined: Places the terminal symbol name into every row where an I/O point is defined from Unity Pro. The defined address from Unity Pro is the topographical address coming from the I/O variable file that contains a value for the address string.</li> </ul>
<b>Include outer terminals</b>	<p>Defines a terminal symbol to place into the spreadsheet on the outer side of the in-line component (between the I/O component and the wire connected to the ladder rail).</p> <ul style="list-style-type: none"> <li>■ All I/O addresses: Places the terminal symbol name into the row of every I/O address listed in the import spreadsheet.</li> <li>■ I/O addresses defined: Places the terminal symbol name into every row where an I/O point is defined from Unity Pro. The defined address from Unity Pro is the topographical address coming from the I/O variable file that contains a value for the address string.</li> </ul>

### **I/O Variable File**

Once you select a module node from the tree selection the data relative to the I/O variable file displays for viewing and editing. The path and file name of

the I/O variable file created from Unity Pro (.xsy) displays at the top of this section of the dialog box.

#### I/O variable file grid

Displays a list of the I/O variables found inside of the Unity Pro I/O Variable export file (.xsy). Remains empty if the selected module does not have addresses (such as power supplies and CPUs). All I/O points for the respective PLC card display in the grid (including the points that are undefined). The total number of I/O points and the order of the data is determined from the topological address in the .xsy file in combination with the PLC definition inside of the AutoCAD Electrical PLC database file (ACE\_PLC.MDB).

---

**NOTE** Single and multiple row selection is allowed.

---

- **Address:** Displays the address string from the Unity Pro I/O Variable export file. This field is not editable in the dialog box.
- **Description:** Displays the comment field string associated to the address from the Unity Pro I/O Variable export file. This field is not editable in the dialog box.
- **Terminal:** Defines the placement of a terminal symbol in line with the PLC I/O point. Select the check box to place a terminal symbol in the spreadsheet and drawing file. Since it is not defined in the Unity Pro export files, it must be defined before creating the AutoCAD Electrical import spreadsheet.
- **Symbol Name:** Displays the AutoCAD Electrical schematic symbol file name to place in line with the PLC I/O points. If the symbol is not found in the schematic symbol library or the custom string is not mapped to a symbol name in the mapping file, the name displays in red. Right-click in this column to select a file name from the icon menu or to clear the symbol name.

The symbol name is derived from the value in the Custom field of the Unity Pro data and the symbol file name that it is mapped to in the mapping file.

- **Device Tag:** Displays the tag value. If left blank, the normal tagging method for parent components is followed while children components remain untagged. Click in the column to enter a value or right-click to copy, cut, or paste a value into the cell.

**Inner terminal symbol**

Specifies the symbol name to insert for inner terminals in the spreadsheet. The default symbol name is HT0001 (a terminal that maintains the wire number potential, has a tag strip ID and terminal number, and is square). Click the Select from Icon Menu button to select a terminal to use from the icon menu.

**Outer terminal symbol**

Specifies the symbol name to insert for outer terminals in the spreadsheet. The default symbol name is HT0001. Click the Select from Icon Menu button to select a terminal to use from the icon menu.

**I/O variable grid right-click options**

Right-clicking in the I/O variable grid control allows you to edit the file before creating the PLC I/O spreadsheet. Multiple selection is allowed.

**Select Symbol**

Displays the icon menu for selection of symbol file names. Selecting a symbol file name fills in an empty grid cell or overwrites the existing text in a cell.

**Select All**

Selects every row in the grid control

**Clear All**

Removes every row from selection.

**Select All Defined I/O**

Makes a selection in the grid for the rows that are defined with I/O addresses.

**Cut**

(single selection only) Cuts the selected value (description, symbol name, or device tag).

**Copy**

Copies the selected value from one or more grid cells.

<b>Paste</b>	Pastes in the selected value from one or more grids into the selected grids.
<b>Apply Terminal Inner</b>	Selects all inner terminals in the grid.
<b>Apply Terminal Outer</b>	Selects all outer terminals in the grid.

### **OK + Run**

Displays the Save As dialog box where you can quickly save the data to a spreadsheet and start the PLC drawing creation automatically. The Spreadsheet to PLC I/O Utility dialog box then opens with the saved spreadsheet already selected.

## **Create XML files for export to Unity Pro**

The Unity Pro Export command creates the Unity Pro I/O variable file (.xsy) in the Unity Pro XML format. You can create the file for the active project or active drawing. AutoCAD Electrical suggests naming the XML data file based on whether you select to export for the project or a drawing. The default file name is either "Projectname.xml" or "Drawing filename.xml."

The Unity Pro export file is generated from the PLC drawings and their respective PLC symbols. To ensure the proper importing and editing of the I/O variable file in Unity Pro, the variable name and variable type are maintained inside of the PLC drawings. Variable names and types are defined inside of Unity Pro and are the required for bidirectional updates.

---

**NOTE** These values are maintained on the PLC module. If you delete the module from the drawing, the variable name and type are also removed.

---

Variable names and types are created for new I/O addresses for import back into Unity Pro. During the AutoCAD Electrical import process, the rest of the addressing is filled in based on the available I/O points on the module. These additional I/O points receive a variable name and type upon import into AutoCAD Electrical.

<b>Variable Name</b>	Takes on the address string as the value.
<b>Variable Type</b>	Takes on the same type as the other defined I/O addresses on the module. If I/O points are not

defined on the module then Boolean characters are used.



## Export a file in the Unity Pro XML format

The AutoCAD Electrical Unity Pro export file is generated from the PLC drawings and their respective PLC symbols. The variable names and types are maintained on the PLC module so that the file can be imported back into Unity Pro.

- 1 Click Import/Export Data tab ➤ Export panel ➤ Unity Pro. 
- 2 In the Unity Pro Export dialog box, select to create an export file (.xsy) for the project or the active drawing and click OK.
- 3 If you selected Project, select the drawings to process and click OK.
- 4 In the Save As dialog box, specify the file name and click Save.  
By default the file is saved in the My Documents folder. AutoCAD Electrical suggests a file name for the XML export file depending on whether you are creating the file for the project or the active drawing.

## Unity Pro export

This tool creates the Unity Pro I/O variable file (.xsy) in the Unity Pro XML format. The XML file contains the PLC I/O addresses and descriptions for import into the Unity Pro software.

 **Ribbon:** Import/Export Data tab ➤ Export panel ➤ Unity Pro. 

 **Toolbar:** Schematic Reports 

 **Menu:** Projects ➤ Reports ➤ Unity Pro Export

 **Command entry:** AEUNITYPRO

Select whether to create an XML export file for the project or for the active drawing.



# Circuits

# 9

## Circuit Builder

### Circuit Builder overview

The Circuit Builder tool comes prepopulated with data to build and annotate a sampling of motor control circuits and power feed circuits. Circuits include 3-phase, single-phase, and one-line circuit representations. Each circuit is built dynamically, adjusting the power bus to match the wire bus for the drawing, adding wiring between components, and annotating the elements with suggested values based upon the selected load. Each time a circuit is configured, it is added to a history list of circuits. This list provides for quick reinsertion at a later time.

Three items control this feature:

- The [spreadsheet](#) on page 655 defines the available circuits, circuit types, and defaults for each option within a circuit.
- The [template](#) on page 659 (.dwg file) for a selected circuit defines the wiring and the placement position for the individual components on that wiring.
- The [electrical standards database](#) on page 663 provides suggested values used to annotate components of the circuit and the wire size and type of the power wiring.

Circuit Builder is customizable. You can add new circuit definitions and edit existing ones.

### Workflow

- 1 Circuit Builder opens the spreadsheet and reads in the first sheet named “ACE\_CIRCS”.
  - 2 Circuit Builder shows the list of defined circuits in the Circuit Selection dialog box.
  - 3 Select a circuit to insert or configure. The associated line from the ACE\_CIRCS sheet provides the base drawing template name, and the name of a circuit code sheet. The circuit code sheet is a separate sheet within the Circuit Builder spreadsheet.
  - 4 The base drawing template for the circuit inserts at your selected location.
  - 5 Circuit Builder finds and reads the attributes on all the special marker blocks on the inserted drawing template.
  - 6 Circuit Builder matches each marker block to a specific section in the circuit codes sheet. This section can be a single spreadsheet row or multiple consecutive rows in the circuit codes sheet. The section identifies one of the following:
    - The action taken at this marker block location in the circuit. For example, calculate a wire type, insert a wire number, or adjust rung spacing.
    - Provides a list of component insertion options that can be inserted at this point in the circuit. For example, presents a selection list containing a fuse, circuit breaker, or disconnect switch symbol.
- Each marker block is processed in sequence, controlled by an ORDER attribute value carried on each marker block
- 7 A marker block can insert a nested template into the main circuit template. If the nested template carries its own marker blocks, these marker blocks are added to the overall list to process. When all marker blocks have been processed, the circuit is complete.

### See also:

- [Customize Circuit Builder](#) on page 2005

## Spreadsheet

The Circuit Builder spreadsheet, `ace_circuit_builder.xls`, along with the template drawings that it references, control what is displayed in the Circuit Selection and Circuit Configuration dialog box options. The first sheet in the spreadsheet, `ACE_CIRCS`, contains the main circuit categories, for example “3ph Motor Circuit”, and types, for example “Horizontal - FVNR - non reversing”. Along with this first sheet, are one or more circuit code sheets. These sheets contain the information necessary to insert or configure a specific circuit selected from the first sheet.

The `ace_circuit_builder.xls` circuit builder spreadsheet can be relocated into any of the normal AutoCAD Electrical or AutoCAD support paths.

The default location for the spreadsheet is:

- **Windows XP:** `C:\Documents and Settings\All Users\Documents\Autodesk\AcadE {version}\Support\`
- **Windows Vista, Windows 7:** `C:\Users\Public\Documents\Autodesk\AcadE {version}\Support\`

The default spreadsheet name, “`ace_circuit_builder.xls`”, can be overridden by setting the environment variable, `WD_CIRCBUILDER_FNAM`, in the `wd.env` on page 1984 file.

### ACE\_CIRCS sheet

Circuit Builder reads the list of circuit categories and types from the first sheet in the spreadsheet, `ACE_CIRCS`. This information appears in a tree-structure selection window in the Circuit Selection dialog box. The `ACE_CIRCS` sheet contains the following columns.

<b>CATEGORY</b>	A major circuit category displayed at the highest level of the tree structure in the Circuit Selection dialog box.
<b>TYPE</b>	The specific type of circuit within a major category. The circuit types appear at the second level of the tree structure.
<b>DWG_TEMPLATE</b>	The drawing template that is inserted when this circuit is selected. If a <code>.dwg</code> extension is not present, it is assumed.
<b>SHEET_NAME</b>	The circuit code sheet name that is referenced for the selected circuit template. This circuit code sheet carries the definitions for all the marker blocks in the selected drawing template and any nested templates.

**ANNO\_CODE** Code maps to the ANNO\_CODE table in the spreadsheet. Allows you to predefine the description, installation, location, and other key information, for the motor or load and the individual components that might be inserted into the circuit.

### Circuit code sheets

Once a circuit is selected from the Circuit Selection dialog box (the CATEGORY and TYPE fields from the ACE\_CIRC sheet), the associated drawing template is inserted (the DWG\_TEMPLATE field), and a related circuit code sheet is ready for reference (the SHEET\_NAME field).

The inserted [drawing template](#) on page 2010 contains special marker blocks. Each marker block contains a CODE attribute with a value. This CODE value is used to match up with a section in the circuit code sheet. The matching section in the circuit code sheet provides the key information on what action is required at this physical location in the circuit.

Each circuit code sheet contains the following columns.

<b>CODE</b>	Value is matched to the CODE attribute value on the marker block. Each code corresponds to one circuit element in the list or an action/decision that takes place at the insertion point of the marker block.
<b>COMMENTS</b>	Text displayed in the Circuit Elements list in the Circuit Configuration dialog box.
<b>UI_DEF</b>	The default option for a circuit element is marked with an "X". When a circuit is inserted rather than configured, all elements marked with "X" are used to build the selected circuit.
<b>UI_TITLE</b>	<p>Title for the group of options in the middle Select section of the Circuit Configuration dialog box. Each circuit element can have one or more groups of options. For example, the main disconnecting means might have two groups of options, the disconnecting means itself and an optional auxiliary contact.</p> <p>This field can also contain a predefined code to bring up a separate dialog instead of driving the middle Select section of the main Circuit Configuration dialog box. There are two pre-defined codes:</p> <ul style="list-style-type: none"><li><b>!MCC_CTRL</b> - invokes the <a href="#">Select Motor</a> on page 710 dialog box when the Browse button on the Motor Setup section of the <a href="#">Circuit Configuration</a> on page 708 dialog box is selected. It must be combined with the ace_cb_motor_select API call in the LOOKUP_CMD entry.</li></ul>

**!PF\_CTRL** - invokes the [Select Load](#) on page 711 dialog box when the Browse button on the Load Setup section of the [Circuit Configuration](#) on page 708 dialog box is selected. It must be combined with the `ace_cb_power_feed_select` API call in the LOOKUP\_CMD entry.

---

**NOTE** Include the `ace_cb_wire_select` API call in the LOOKUP\_CMD entry to invoke the [Wire Size Lookup](#) on page 712 dialog box when the Browse button in the Wire Setup section of the Circuit Configuration dialog box is selected.

---

<b>UI_PROMPT_LIST</b>	The text to display in the middle Select section for each option within this group.
<b>UI_VAL</b>	<p>A numerical value assigned to the selection from each group. These numerical values are added up and matched to the value in the UI_SEL column.</p> <hr/> <p><b>NOTE</b> This value must be inserted as a text value in the spreadsheet and not as a number. An apostrophe character in front of the number forces the spreadsheet software to interpret it as a text value. You can also format the cells specifically as text. The text appears left justified in the cell.</p> <hr/>
<b>UI_SEL</b>	<p>A numerical value matched to the sum total of the values in the UI_VAL column for each selection made within a group. The COMMAND_LIST value from this row is used to insert the selected options.</p> <hr/> <p><b>NOTE</b> This value must be inserted as a text value in the spreadsheet and not as a number. An apostrophe character in front of the number forces the spreadsheet software to interpret it as a text value. You can also format the cells specifically as text. The text appears left justified in the cell.</p> <hr/>
<b>COMMAND_LIST</b>	<p>The command calls to insert the selected options.</p> <hr/> <p><b>NOTE</b> These calls are generally set up using standard AutoLISP format. Multiple calls can be concatenated in the same cell or in subsequent rows of the sheet. If multiple rows are used, the UI_SEL value cell is repeated. Anything after a semi-colon character is interpreted as a comment</p> <hr/>
<b>ANNOTATE_LIST</b>	Optional command calls to annotate the circuit element. The ANNOTATE_LIST calls execute after all rows of the COMMAND_LIST calls have executed.

<b>LOOKUP_CMD</b>	Optional command calls to perform the electrical standards database or catalog lookups for the selected circuit element. This field controls the right-hand side of the Circuit Configuration dialog.
<b>TABLEn</b>	Optional catalog lookup table name. If the option contains multiple components, such as a disconnect switch and a fuse, there are multiple columns where “n” increments for each component.
<b>TITLEn</b>	The title for the component within the Setup & Annotation section on the Configuration dialog box. If the option contains multiple components, such as a disconnect switch and a fuse, there are multiple columns where “n” increments for each component.

### **ANNO\_CODE sheet**

Allows you to predefine the description, installation, location, and other key information for the motor or load and the individual components inserted into the circuit.

<b>ANNO_CODE</b>	Value is matched to the ANNO_CODE value from the ACE_CIRCS sheet.
<b>CODE</b>	Value is matched to the CODE value of the marker block on the circuit template.
<b>ATTRIBUTE</b>	Attribute name on the component inserted at the position of the marker block.
<b>PROMPT</b>	Text prompt displayed in the Annotation Presets dialog box.
<b>DEFAULT</b>	The default value for the attribute if annotation presets are <a href="#">listed</a> on page 708 or <a href="#">applied</a> on page 706. This value can be a text value or an AutoLISP expression that returns a text value.
<b>OPTIONS</b>	Future

### **How Annotation Presets work**

- 1 Make a selection from the Circuit Selection dialog box, for example "Horizontal - FVNR - non reversing". This selection has a value in the ANNO\_CODE cell, "ANNO\_3M".
- 2 Circuit Builder finds the group of entries that match up with code "ANNO\_3M" in the ANNO\_CODE sheet of ace\_circuit\_builder.xls.

- 3 If any matching entries are found, the Special Annotation: Presets section of the Circuit Selection dialog box, is enabled.
- 4 If you select Presets and click the Presets List button, the Annotation Presets dialog box displays. The rows displaying the entries with non-blank DEFAULT values are initially marked as Selected.
- 5 Edit the attribute values as necessary and click OK.
- 6 Select to Insert or Configure the circuit.
- 7 Circuit Builder processes each marker block on the circuit template. If the CODE value matches the CODE value from the ANNO\_CODE rows, the attribute values marked as Selected in the Annotation Presets dialog box are applied to the target attributes of the inserted component. If a target attribute is not found, the value is inserted as an Xdata value.

## Drawing templates

Each circuit starts with a main drawing template. These main circuit template drawings are named “ace\_cb1\*.dwg”. Branching or nested circuit drawing templates are named “ace\_cb2\*.dwg”. A branching circuit is a circuit inserted as an option on to the main circuit, for example a control transformer circuit or a power factor correction circuit.

The circuit drawing templates use the following naming convention.

- ace\_cb1\_\*.dwg - primary circuit drawing templates
- ace\_cb2\_\*.dwg - branching or nested circuit drawing templates

The default location for the circuit drawing templates is the schematic library folder:

- **Windows XP:** C:\Documents and Settings\All Users\Documents\Autodesk\AcadE {version}\Libs\{library}\
- **Windows Vista, Windows 7:** C:\Users\Public\Documents\Autodesk\AcadE {version}\Libs\{library}\

One-line template drawings have a “1-” suffix. The default location is in a “1-” folder under the schematic library folder.

- **Windows XP:** C:\Documents and Settings\All Users\Documents\Autodesk\AcadE {version}\Libs\{library}\1-

- **Windows Vista, Windows 7:** C:\Users\Public\Documents\Autodesk\AcadE{version}\Libs\{library}\1-

---

**NOTE** This template drawing naming convention is recommended but is not required for Circuit Builder to function.

---

A circuit template contains the wiring framework for the circuit and special marker blocks. These marker blocks are nothing more than instances of a standard AutoCAD block, `ace_cb_marker_block`, carrying three attributes. These marker blocks tell Circuit Builder that some action or decision is required at the insertion point of the marker block. The action can be:

- Insert a component.
- Insert a multi-pole component.
- Make a wire type assignment to the underlying wire.
- Insert a wire number on the underlying wire.
- Decide if a branching circuit is needed.
- Decide if an underlying wire stretches and connects to a nearby power bus.
- Decide if underlying wire bus spacing adjusts.
- Decide if an underlying wire is trimmed.
- Set up the circuit annotation.

---

**NOTE** If you choose to Insert a circuit, bypassing the Circuit Configuration dialog box, the default options, as defined in the [Spreadsheet](#) on page 655, for each circuit element are used.

---

### Marker block attributes

<b>CODE</b>	This attribute value provides the link between the marker block on the circuit template drawing and a section in the circuit codes sheet. The value on this attribute matches with the CODE column value in the circuit codes sheet for the selected template.
<b>ORDER</b>	This attribute value controls the sequence of circuit element display and insertion within the circuit. Marker blocks are processed in order, from low to high. Assigning the same order value to multiple marker blocks links multiple marker blocks together for processing as a group. For example, to adjust the spacing between multiple wires



of a 3-phase bus there are three marker blocks with a common CODE value and a common ORDER value. The ORDER value can be an integer or a decimal number value. Support for decimal number order values makes it easy to add a marker block between two others without having to reorder everything.

## MISC1

This attribute value contains miscellaneous annotation values, actions, and flags. Annotation values are in the format <attribute name>=<attribute value>. Actions can include embedded AutoLISP expressions or programs. Flags are key words that include enabling child contacts to link to parents and overriding multi-pole build directions. Flag codes include the following

- **\_TAGFMT=<value>** - override the drawing property component tag format or wire number format setting for this one instance.
- **\_PRETAG=<value>** - predefine a default alias tag for parent child linking. This option can be used for situations when the child component is inserted before the parent. For example, the marker block for the child contact has "\_PRETAG=MR". When the parent coil is inserted, its marker block also has "\_PRETAG=MR". As the circuit completes, the actual tag value of the parent annotates on to the child contact. This action is based upon the matching "MR" alias assigned to each.
- **\_WIRENO=<value>** - predefine a fixed wire number.
- **WIRENUMBERS=0** - if a required wire type does not exist, create it and mark it as No Wire Numbering. If a required wire type does not exist and this flag is missing or has a value of 1, create it and mark it as Wire Numbering.
- **\_WIRETYPE=<value>** - predefine the wire type layer name.
- **\_WIRESKIP=<value>** - number of wires to skip over when trying to connect to another wire.
- **\_MAXTRAPCOUNT=<value>** - maximum search distance to look for a wire connection, given in wire connection trap units. The wire connection trap value is fixed and is displayed on the [Drawing properties: drawing format tab](#) on page 231 for the active drawing.
- **\_BASE** - indicates a base wire, the one that does not move, when setting up to adjust multiple bus wire spacing. If not defined, the wire that is co-linear with the insertion point of the template becomes the default base wire.
- **\_L =<value>**- each sublist, delimited by "|" characters, can predefine attribute values for individual poles of a multi-pole component, set of terminals, or set of cable markers.
- **\_D=<value>** - define the build direction override for a multi-pole component. 1=build right, 2=build up, 4=build left, 8=build down. Without an override, the build direction is down for horizontal inserts, and from left to right for vertical inserts.

- $X=<value\ or\ AutoLISP\ expression>$  - reposition the marker block in the "X" direction. For example, " $\_X>(*\ 0.5\ DIST01)$ " means adjust the position of this marker block in the X direction by an amount equal to 0.5 times the bus spacing distance defined by marker block with a CODE attribute value of "DIST01". This example can be used to position a marker block for a single phase motor insertion point, halfway between two power bus wires.
- $\_Y=<value\ or\ AutoLISP\ expression>$  - reposition the marker block in the "Y" direction.

---

**NOTE** The flags defined in the circuit drawing marker blocks override any spreadsheet settings.

---

### Marker block functions

All marker blocks have the same block name, `ace_cb_marker_block`, but can have a wide variety of functions. The specific function assigned to a marker is based on its CODE attribute value and what this code value maps back to in the circuit code sheet for the circuit template. Here are the categories of marker block functions:

<b>Setup</b>	Blocks that define the circuit properties, such as motor selection.
<b>Wire Type</b>	Blocks that define the wire type layers layer to assign to the wire network under the block.
<b>Wire Number</b>	Blocks that define a wire number to assign to the wire under the block.
<b>Nested Circuit</b>	Blocks that define the placement of a branching or nested circuit such as a control circuit at the insertion point of the marker block.
<b>Component</b>	Blocks that define the placement of a component, connector, terminal, cable marker, or a multi-pole component at the insertion point of the marker block.
<b>Bus Spacing</b>	Blocks that control rung spacing adjustment for the wires under these blocks. Blocks that are processed as a group must carry common CODE and ORDER attribute values.
<b>Wire Connections</b>	Blocks that control stretching a wire segment to connect to another wire.

---

**NOTE** The name of the marker block cannot be changed. The Circuit Builder command only processes marker blocks named "`ace_cb_marker_block`".

---

### One-line circuit templates

One-line circuit templates use the same marker block concept as three-phase motor and power feed circuit templates. However, there are a few differences. There is a single line wire that represents a multi-wire bus. Most of the one-line circuit templates contain a special "bus-tap" symbol.

The bus-tap symbol can have two functions:

- Provide an anchor point for the one-line circuit representation that begins at this location.
- Break into the one-line bus where the circuit connects.

On a dual circuit one-line template, there are three of bus-tap symbols. One at the normal point where the circuit ties into the bus. There is another version of the symbol on each of the two circuit "legs", each marking the point where that part of the dual circuit starts. These bus-tap symbols allow various reports to report accurately on a one-line circuit, whether a single circuit or a dual circuit representation.

The following bus-tap symbols are supplied:

- HDV1\_BT\_1-.dwg - with "dot" for horizontal one-line circuit
- VDV1\_BT\_1-.dwg - with "dot" for vertical one-line circuit
- HDV1\_BTT\_1-.dwg - "tee" connection for dual horizontal circuit
- VDV1\_BTT\_1-.dwg - "tee" connection for dual vertical circuit
- HDV1\_BTL\_1-.dwg - "corner" connection for dual horizontal circuit
- VDV1\_BTL\_1-.dwg - "corner" connection for dual vertical circuit

---

**NOTE** A WDTYPE attribute with a "1-1" value, identifies a bus-tap symbol.

---

## Electrical standards database file

Circuit Builder uses an electrical standards database to define default values, define engineering calculations, annotate circuits, and provide wire size recommendations. The electrical standards database,

ace\_electrical\_standards.mdb, is located in the catalog folder. The default location is:

- **Windows XP:** C:\Documents and Settings\{username}\My Documents\Acade {version}\AeData\Catalogs\
- **Windows Vista, Windows 7:** C:\Users\{username}\Documents\Acade {version}\AeData\Catalogs\

Sizing and wire type values are based on information from the electrical standards database. Circuit Builder looks for a match on the motor size, supply voltage, and phase. On a match, Circuit Builder provides the Full Load Amp value, recommended motor power conductor size, and suggested rating values for various branch circuit protection elements such as circuit breakers, fuses, and disconnect switches.

The electrical standards database also allows Circuit Builder to provide engineering estimates and “green” calculations in the area of power conductor size versus energy losses. Designing to meet minimum code requirements can conflict with green design. For example, designing to the minimum conductor size for a given load can provide short-term savings on material cost but run up longer-term expense due to higher heating losses in the wiring. Over the life of the installation, the energy lost in heating up the minimum-sized wiring, instead of reaching the load to do useful work, could be substantial.

During wiring sizing, Circuit Builder displays not only a list of the valid wire sizes meeting the ampacity requirements of the load, but also a list of the estimated maximum energy loss cost for each wire size. This set of calculations allows you to make better green design decisions. For example, you decide to oversize the conductors for a motor to reduce conductor heating losses. This results in a higher initial cost for material and installation labor. However, this cost is recovered many times over in reduced energy losses in the wiring during the life of the installation.

---

**NOTE** The ace\_electrical\_standards.mdb file replaces the mcc.mdb file used in previous versions of Circuit Builder.

---

The electrical standards database contains multiple tables used by Circuit Builder.

**MOTOR**

Contains the values used to populate the [Select Motor](#) on page 710 dialog box.

<b>FEED</b>	Contains the values used to populate the <a href="#">Select Load</a> on page 711 dialog box. This table name can have an optional suffix to relate it to a specific electrical standards code.
<b>OPT</b>	Options tables contain values defining defaults and options lists specific to an electrical standard. For example, default to copper wiring, AWG size standard, and feet for conductor length units.
<b>AMP_{wire type}_{wire size standard}</b>	Wire ampacity tables contain the ampacity ratings for different conductor sizes and insulation temperature ratings.
<b>AMPG_{wire type}_{wire size standard}</b>	Grounding conductor sizing tables contain the maximum ampacity ratings for different grounding conductor sizes. This information is used to retrieve the minimum grounding conductor size and provide a selection list of larger sizes.
<b>INSUL_{wire type}_{wire size standard}</b>	Wire insulation tables lists the insulation types, the maximum temperature rating for each, and de-rating factors for each based on a series of temperatures.
<b>XL&amp;R_{wire type}_{wire size standard}</b>	Conductor Reactance/AC Resistance tables contain values used to estimate single-phase and three-phase voltage drop values.
<b>XL&amp;R_DESC</b>	Conduit/raceway descriptions list used with the XL&R_{wire type}_{wire size standard} tables.
<b>FILL</b>	Fill tables contain the ampacity de-rating factors used when there is more than one current carrying conductor (power wiring, not ground, neutral, or control wires) in the same conduit, duct, or raceway.
<b>MOTOR_I_DESC</b>	Lists the component type descriptions whose sizing ties directly into the full load amps value (FLA) of the motor or load. The CODE value maps to the MOTOR_I_CALC and MOTOR_I_MAP tables.
<b>MOTOR_I_CALC</b>	Lists the formula to calculate the maximum amp value for various types of components on a per motor type basis.
<b>MOTOR_I_MAP</b>	Maps the calculated FLA for a component to a specific rating value and an optional catalog assignment.

---

**NOTE** Each table name can have an optional suffix to relate it to a specific electrical standards code.

---

### **Motor table**

The data in the Motor table is used to populate the [Select Motor](#) on page 710 dialog box. Filter the selection list by type, voltage, and frequency. The load and FLA values for the selected motor are passed back to the Circuit Configuration dialog box and are used in wire size calculations. The values are also used to calculate breaker size, fuse size, and disconnect switch rating, for the selected motor.

The MOTOR table follows this table naming convention:

- MOTOR - if no specific electrical standards table is found, the default table name to use.
- `_{standard}` - optional suffix to relate it to a specific electrical standards code. For example, an “\_NEC” suffix could mean that the data for the table parallels the National Electrical Code. A suffixed MOTOR table name is not necessary unless you plan to set up the electrical standards database to support multiple standards.

### **Feed table**

The data in the Feed table is used to populate the [Select Load](#) on page 711 dialog box. Filter the selection list by type, voltage, and frequency. The load and FLA values for the selected feed are passed back to the Circuit Configuration dialog box and are used in wire size calculations. The values are also used to calculate breaker size, fuse size, and disconnect switch rating, for the selected load.

The FEED table follows this table naming convention:

- FEED - if no specific electrical standards table is found, the default table name to use.
- `_{standard}` - optional suffix to relate it to a specific electrical standards code. For example, an “\_NEC” suffix could mean that the data for the table parallels the National Electrical Code. A suffixed FEED table name is not necessary unless you plan to set up the electrical standards database to support multiple standards.

## Options tables

Options tables contain values defining defaults and options lists specific to an electrical standard. For example, default to copper wiring, AWG size standard, and feet for conductor length units.

The OPT table follows this table naming convention:

- OPT - if no specific electrical standards table is found, the default table name to use.
- `_{standard}` - optional suffix to relate it to a specific electrical standards code. For example, an “\_NEC” suffix could mean that the data for the table parallels the National Electrical Code. A suffixed OPT table name is not necessary unless you plan to set up the electrical standards database to support multiple standards.

Name	Description
FLA_MULT	<p>Default full load amps multiplier value used to determine a maximum load. For example, the full load amps for a motor is rated at 10 amps and the FLA_MULT default is set to 1.25. The minimum wire size calculation for the wiring for the motor is based upon an ampacity rating of not 10 amps but 12.5 amps (10 amps x 1.25).</p> <p>The FLA_MULT factor displays in the <a href="#">Select Motor</a> on page 710 and <a href="#">Wire Size Lookup</a> on page 712 dialog boxes.</p>
C_LOAD	<p>Continuous load correction factor for wire size ampacity de-rating. If the electrical load is anticipated to be a continuous load, a default de-rating factor can be automatically applied to the wire size ampacity calculation.</p> <p>For example, a given electrical code defines the Continuous load correction factor at a value of 0.8. This means that a given wire size that normally has a maximum rated ampacity value of 20 amps is de-rated to a maximum ampacity of 16 amps when the wiring is to power a motor that is expected to be a continuous load. The wire size calculation may need to select the next larger wire size.</p>
W_METAL	<p>Default wire metal value used to determine appropriate wire ampacity and wire insulation table names. For example, “CU” to define copper wiring as the default, “AL” to define aluminum wiring as the default.</p>
W_STD	<p>Default wire type standard used to determine appropriate wire ampacity and wire insulation table names. For example, “AWG” or “MM2”.</p>

Name	Description
V_DROP	Maximum allowable % voltage drop in power wiring. This value can be used to help calculate an appropriate wire size when the wire run distance is also defined.
W_INSUL	Default insulation type used to determine the ambient temperature correction factor.
LEN_LIST	Wire run distance values for pick list in the Wire Size Lookup dialog box. The run distance is used for estimated voltage drop calculations in the motor or load power wiring.
LEN_UNITS	Run distance units for power conductors and values for units pick list in the Wire Size Lookup dialog box. Run distance is used in the estimated voltage drop calculation. Units are either "FT" for feet or "M" for meters.
KWH_COST	Unit cost per kWh. This value is used for estimating a maximum annual cost of energy loss in the power wiring for a motor or load, assuming a continuous full load.
KWH_COST_UNITS	KWh cost units character used in the Wire Size Lookup dialog box showing the wire loss estimates. For example, "\$" for dollar, "€" for euro.
SHORTNAME	The code for the electrical standards name for this table. This <a href="#">code</a> on page 182 is saved in the project <i>.wdp</i> file when the standard is applied to a project.
FULLNAME	The full name of the electrical standards name for this table. This value, extracted from all the OPT tables, provides the values for the pick list when setting an Electrical Code Standard for a project from the <a href="#">Project properties: project settings tab</a> on page 204.
LEN_UNITS	Run distance units for power conductors and values for units pick list in the Wire Size Lookup dialog box. Run distance is used in the voltage drop calculation.
VOLTS	Default supply voltage value and values for voltage pick list in the Wire Size Lookup dialog box.
PHASE	Default supply phase value and values for phase pick list in the Wire Size Lookup dialog box. For example, "1" for single-phase, "3" for three-phase.
PARALLEL_MIN_SIZE	Default value for the minimum wire size when displaying paralleled wire option in the Wire Size Lookup dialog box. For example, "1-0 AWG".



<b>Name</b>	<b>Description</b>
<b>PARALLEL_MAX_CNT</b>	Default value for the maximum number of wire conductors when displaying paralleled wire option in the Wire Size Lookup dialog box. For example, "4" for up to four paralleled wires per phase.
<b>T_AMBIENT</b>	Default ambient temperature correction factor. This value is used in wire type sizing. It must match up with one of the temperature de-rating column labels found in the INSUL_* tables. For example, "30C".
<b>M_POWERFACTOR</b>	Default power factor for a motor. This value is used in estimated voltage drop calculations. For example, "0.85".
<b>F_POWERFACTOR</b>	Default power factor for a power feed. This value is used in estimated voltage drop calculations. For example, "0.85".
<b>AMPG_MAX</b>	Defines the expression to calculate the minimum grounding conductor ampacity size. The "I" in the expression represents the motor or load full load amps (FLA). The result of the expression is then applied to the appropriate AMPG table to determine the minimum grounding conductor size.

CODE	DEFAULT	LIST
FLA_MULT	1.25 <b>1</b>	
C_LOAD	0.8 <b>2</b>	
W_METAL	CU <b>3</b>	
W_STD	AWG <b>4</b>	
V_DROP	3 <b>5</b>	2,3,4,5 <b>6</b>
W_INSUL	THWN <b>7</b>	
LEN_LIST		20;50;75;100;150;200;250 <b>8</b>
KWH_COST	0.08 <b>9</b>	
KWH_COST_UNITS	\$ <b>10</b>	€, \$
SHORTNAME	Default (NEC)	
FULLNAME	Default (National Electrical Code)	
LEN_UNITS	FT <b>11</b>	FT,M <b>12</b>
VOLTS	480 <b>13</b>	120;208;240;480;575;600 <b>14</b>
PHASE	3 <b>15</b>	1,3 <b>16</b>
PARALLEL_MIN_SIZE	1-0 <b>17</b>	
PARALLEL_MAX_CNT	4 <b>18</b>	
T_AMBIENT	30C <b>19</b>	
M_POWERFACTOR	0.85 <b>20</b>	0.80;0.85;0.90;1.0 <b>21</b>
F_POWERFACTOR	1.0 <b>22</b>	0.80;0.85;0.90;1.0 <b>23</b>
AMPG_MAX	(I* 1.75) <b>24</b>	

**Wire Size Lookup**

**Load:** Voltage: 480 **13/14**, Phase: 15/16, FLA: 61.2, FLA multiplier: 1.25 **1**, Maximum load: 76.5  
**Wire:** Size standard: AWG **4**, Type/method: CU **3**, Insulation: THWN / 75C **7**  
**De-rating factors:** Continuous load correction: 0.8 **2**, Fill correction: 1.0, Ambient temperature correction: 26-30C **19**, Total correction: 0.8  
**Parameters:** Run distance: 20 **8**, Units: FT **11/12**, Via: Steel Conduit, Power factor: 0.85 **20-23**, Maximum % voltage drop: 3 **5/6**  
**Paralleled wires:** Include paralleled wire options: Maximum paralleled wire count: 4 **18**, Minimum paralleled wire size: 1-0 **17**, Cost per kwh: 0.08 **9**

\*Maximum **10** of wire losses for continuous use at rated load

Size	Count	Fill	Ampacity	%Ampacity	Voltage Drop	%Voltage Drop	Wire KW Loss	Wire Loss estimate(maximum annual cost)
10 AWG	1	1-3	30	255	2.21	0.46	0.23	\$ 161.29
8 AWG	1	1-3	50	153	1.48	0.31	0.16	\$ 112.20
6 AWG	1	1-3	65	117.69	0.96	0.2	0.1	\$ 70.13
4 AWG	1	1-3	85	90	0.63	0.13	0.07	\$ 49.09
3 AWG	1	1-3	100	76.5	0.52	0.11	0.06	\$ 42.08
2 AWG	1	1-3	115	66.52	0.43	0.09	0.05	\$ 35.06
1 AWG	1	1-3	130	58.85	0.35	0.07	0.04	\$ 28.05
1-0 AWG	1	1-3	150	51	0.28	0.06	0.03	\$ 21.04
1-0 AWG	1	4-6	120	63.75	0.28	0.06	0.03	\$ 21.04
1-0 AWG	1	7-9	105	72.86	0.28	0.06	0.03	\$ 21.04
2-0 AWG	1	1-3	175	43.71	0.24	0.05	0.03	\$ 21.04
2-0 AWG	1	4-6	140	54.64	0.24	0.05	0.03	\$ 21.04

6 AWG **24** Grounding conductor size

Description:  Save as... OK Cancel Help

### Wire ampacity tables

The wire ampacity tables provide the wire conductor sizes, descriptions, and maximum FLA ampacity values based on wire size and standard insulation temperature ratings. This information is used in the following ways:

- Automatically select a default wire size based upon the maximum load amp value displayed in the [Select Motor](#) on page 710 or [Select Load](#) on page 711 dialog boxes.

- Automatically calculate or recalculate suggested wire sizes in the [Wire Size Lookup](#) on page 712 dialog box as various parameters and de-rating factors are applied.

The wire ampacity tables use the following naming convention:

- AMP - the table name prefix.
- `_{type}` - the wire metal type such as CU for copper, or AL for aluminum.
- `_{size}` - wire size standard such as AWG, or MM2 for metric.
- `_{standard}` - optional suffix to relate it to a specific electrical standards code. For example, an “\_NEC” suffix could mean that the data for the table parallels the National Electrical Code. A suffixed table name is not necessary unless you plan to set up the electrical standards database to support multiple standards.

For example, a table named AMP\_CU\_AWG\_NEC contains the wire ampacity information for copper, AWG sizes, and parallels what is found in the National Electrical Code.

Name	Description
SIZE	Wire size code. This value can be automatically pushed into a wire type layer name. For example, “12”, “250KCMIL”.
SIZE_DESC	Wire size description shown on the Wire Size Lookup dialog box. For example, “12 AWG”, “250 KCMIL”.
CIRC_MIL	Imperial cross-section value for the wire conductor size.
60C, 75C, 90C	Maximum ampacity rating values for the wire conductor size for each of these standard ambient temperature ratings. Additional columns can be added or an existing column can be deleted. For example, if local electrical codes do not support 90C, this field can be removed from the table and does not show up as an option in the Wire Size Lookup dialog box.

The screenshot shows a software interface for wire size selection. At the top, a table titled 'AMP\_AL\_AWG\_NE' lists wire sizes and their characteristics. Below it, a 'Wire Size Lookup' dialog box is open, showing various input parameters and a table of results. Annotations with numbers 1, 2, and 3 indicate the flow of data:

- 1**: Points to the '90C' column in the top table and the 'Ambient temperature correction' field in the dialog.
- 2**: Points to the 'Total correction' field in the dialog, which is calculated as 0.406.
- 3**: Points to the 'Size' column in the bottom table, where the value '14 AWG' is highlighted.

The 'Wire Size Lookup' dialog includes the following sections:

- Load:** Voltage (208), Phase (3), FLA (2.08), FLA multiplier (1.25), FLA (Other) (3.25), Maximum load (5.85).
- Wire:** Size standard (AWG), Type/method (CU), Insulation (TBS/90C).
- Derating factors:** Continuous load correction (0.8), Fill correction (7-9, 0.7), Ambient temperature correction (61-70C, 0.58), Total correction (0.406).
- Parameters:** Run distance (20), Units (FT), Via (Steel Conduit), Power factor (0.85), Maximum % voltage drop (3).
- Paralleled wires:** Include paralleled wire options (unchecked), Maximum paralleled wire count (4), Minimum paralleled wire size (1-0).
- Cost per kwh:** 0.08.
- Table:**

Size	Ampacity	%Ampacity	Voltage Drop	%Voltage Drop	Wire KW Loss	Wire Loss estimate(maximum annual cost)
14 AWG	6.09	96.06	0.5	0.24	-	-
12 AWG	8.12	72.04	0.32	0.15	-	-
10 AWG	12.18	48.03	0.19	0.09	-	-
8 AWG	22.33	26.2	0.13	0.06	-	-
6 AWG	30.45	19.21	0.08	0.04	-	-
4 AWG	38.57	15.17	0.05	0.02	-	-
3 AWG	44.66	13.1	0.04	0.02	-	-
2 AWG	52.78	11.08	0.04	0.02	-	-
1 AWG	60.9	9.61	0.03	0.01	-	-
1-0 AWG	69.02	8.48	0.02	0.01	-	-
2-0 AWG	79.17	7.39	0.02	0.01	-	-
3-0 AWG	91.35	6.4	0.02	0.01	-	-

## Grounding conductor sizing tables

The grounding conductor sizing tables provide the grounding wire conductor sizes and maximum FLA ampacity values. This information is used in the following ways:

- Provide a suggested minimum grounding conductor size based on the amp value returned by the expression defined in the AMPG\_MAX entry in the OPT table.

- Provide a selection list on the [Wire Size Lookup](#) on page 712 dialog box giving this minimum suggested size plus all larger grounding conductor sizes.

The grounding conductor sizing tables use the following naming convention:

- AMPG - the table name prefix
- `_{type}` - the wire metal type such as CU for copper, or AL for aluminum.
- `_{size}` - wire size standard such as AWG, or MM2 for metric.
- `_{standard}` - optional suffix to relate it to a specific electrical standards code. For example, an “\_NEC” suffix could mean that the data for the table parallels the National Electrical Code. A suffixed table name is not necessary unless you plan to set up the electrical standards database to support multiple standards.

For example, a table named AMPG\_CU\_AWG\_NEC contains the grounding conductor sizing information for copper, AWG sizes, and parallels values found in the National Electrical Code.

Name	Description
SIZE	Wire size code. This value can be automatically pushed into a wire type layer name for the ground wire. For example, “12”, “250KCMIL”.
SIZE_DESC	Wire size description shown on the Wire Size Lookup dialog box. For example, “12 AWG”, “250 KCMIL”.
MAX	Maximum amp value associated to this grounding wire size. The value comes from the result of the expression held in the AMPG_MAX entry of the OPT table.

### Wire insulation tables

The wire insulation tables provide the option to de-rate wire conductor ampacity based upon expected maximum ambient temperature.

- Automatically select a default wire size based upon the maximum load amp value, displayed in the [Select Motor](#) on page 710 or [Select Load](#) on page 711 dialog boxes, and the default insulation type and ambient temperature rating defined in the W\_INSUL and T\_AMBIENT entries of the OPT table.

- Automatically calculate or recalculate suggested wire sizes in the [Wire Size Lookup](#) on page 712 dialog box as various insulation and temperature de-rating factors are applied.

The wire insulation tables use the following naming convention:

- INSUL - the table name prefix.
- `_{type}` - the wire metal type such as CU for copper, or AL for aluminum.
- `_{size}` - wire size standard such as AWG, or MM2 for metric.
- `_{standard}` - optional suffix to relate it to a specific electrical standards code. For example, an “\_NEC” suffix could mean that the data for the table parallels the National Electrical Code. A suffixed table name is not necessary unless you plan to set up the electrical standards database to support multiple standards.

For example, a table named INSUL\_CU\_AWG\_NEC contains the wire insulation information for copper, AWG sizes, and parallels values found in the National Electrical Code.

<b>Name</b>	<b>Description</b>
INSUL	Insulation type code.
INSUL_DESC	Insulation type description shown on the Wire Size Lookup dialog box.
TEMP	Standard, maximum temperature rating for the insulation type.
25C-80C	A series of wire conductor ampacity de-rating factor values for maximum ambient temperature. Columns can be added or deleted. For example, if 30C is the minimum ambient temperature rating, the 25C column can be removed.

ID	INSUL	INSUL_DESC	TEMP	25C	30C	35C	40C	45C	50C	55C	60C	70C	80C
1	TW	TW	60C	1.08	1	0.91	0.82	0.7	0.58	0.41			
2	UF	UF	60C	1.08	1	0.91	0.82	0.7	0.58	0.41			
3	RHW	RHW	75C	1.05	1	0.94	0.88	0.8	0.75	0.67	0.58	0.33	
4	THHW	THHW (wet)	75C	1.05	1	0.94	0.88	0.8	0.75	0.67	0.58	0.33	
5	THW	THW	75C	1.05	1	0.94	0.88	0.8	0.75	0.67	0.58	0.33	
6	THWN	THWN	75C	1.05	1	0.94	0.88	0.8	0.75	0.67	0.58	0.33	
7	XHHW	XHHW (wet)	75C	1.05	1	0.94	0.88	0.8	0.75	0.67	0.58	0.33	
8	USE	USE	75C	1.05	1	0.94	0.88	0.8	0.75	0.67	0.58	0.33	
9	ZW	ZW	75C	1.05	1	0.94	0.88	0.8	0.75	0.67	0.58	0.33	
10	TBS	TBS	90C	1.04	1	0.96	0.91	0.8	0.82	0.76	0.71	0.58	0.41
11	SA	SA	90C	1.04	1	0.96	0.91	0.8	0.82	0.76	0.71	0.58	0.41
12	SIS	SIS	90C	1.04	1	0.96	0.91	0.8	0.82	0.76	0.71	0.58	0.41
13	FEP	FEP	90C	1.04	1	0.96	0.91	0.8	0.82	0.76	0.71	0.58	0.41
14	FEPB	FEPB	90C	1.04	1	0.96	0.91	0.8	0.82	0.76	0.71	0.58	0.41

### Conductor Reactance / AC Resistance tables

The optional conductor reactance/AC resistance tables provide the reactance and resistance values for wire size based on conduit type. These values are used to calculate the voltage drop percentage in power wiring when a run distance is supplied.

There are two types of tables for this feature. A conduit type description table and the reactance/resistance data tables.

#### Conduit type description table

The description table, XL&R\_DESC, contains the labels used on the [Wire Size Lookup](#) on page 712 dialog box for the conduit or raceway type selection list. The labels also map to the columns in the data tables.

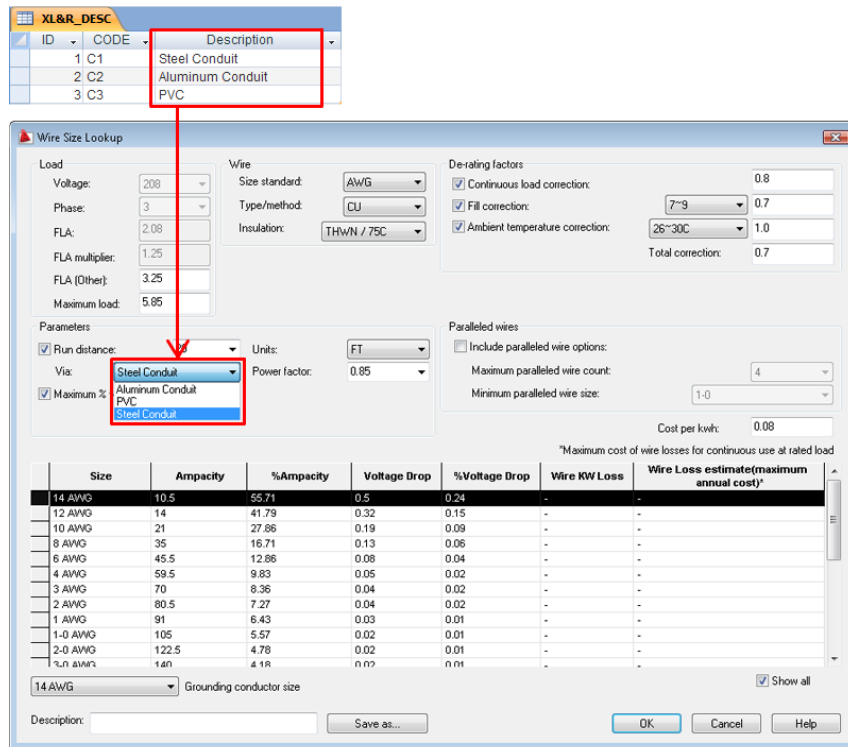

### Data tables

The conductor reactance/AC resistance data tables use the following naming convention:

- XL&R - the table name prefix
- `_{type}` - the wire metal type such as CU for copper, or AL for aluminum.
- `_{size}` - wire size standard such as AWG, or MM2 for metric.
- `_{standard}` - optional suffix to relate it to a specific electrical standards code. For example, an “\_NEC” suffix could mean that the data for the table parallels the National Electrical Code. A suffixed table name is not necessary unless you plan to set up the electrical standards database to support multiple standards.



For example, a table named XL&R\_CU\_AWG\_NEC contains the conductor reactance/AC resistance information for copper, AWG sizes, and parallels values found in the National Electrical Code.

Name	Description
SIZE	Wire size code.
C1-C3	A set of reactance and resistance values, semi-colon delimited for the conduit type. The first element is the estimated reactance and the second element is the AC resistance.

**NOTE** see the XL&R\_DESC table for the corresponding label for each. Data for additional conduit/raceway types can be added to this table with a corresponding entry added to the XL&R\_DESC table.

The screenshot shows two tables at the top. The left table, XL&R\_DESC, has columns ID, CODE, and Description. The right table, XL&R\_CU\_AWG\_NEC, has columns ID, SIZE, C1, C2, and C3. Below these is the 'Wire Size Lookup' dialog box. In the 'Parameters' section, the 'Via' dropdown is set to 'Steel Conduit'. A red box highlights this dropdown. A red arrow points from the 'Steel Conduit' entry in the XL&R\_CU\_AWG\_NEC table to a text box that says 'Used in calculation for Voltage Drop'. Another red arrow points from this text box to the '%Voltage Drop' column in the lookup table. The lookup table has columns: Size, Ampacity, %Ampacity, Voltage Drop, %Voltage Drop, Wire KW Loss, and Wire Loss estimate (maximum annual cost').

**NOTE** See [Wire Size Lookup](#) on page 712 for the voltage drop calculation.

### **Fill tables**

When multiple current carrying wire conductors are in the same conduit, duct, or raceway, the wire ampacity may need to be de-rated. Current carrying wire conductors are defined as power wiring, not ground, neutral, or control wires. The Fill table provides the de-rating factor based on the maximum number of power wire conductors.

The FILL table follows this naming convention:

- FILL - the table name prefix.
- `_{standard}` - optional suffix to relate it to a specific electrical standards code. For example, an “\_NEC” suffix could mean that the data for the table parallels the National Electrical Code. A suffixed FILL table name is not necessary unless you plan to set up the electrical standards database to support multiple standards.

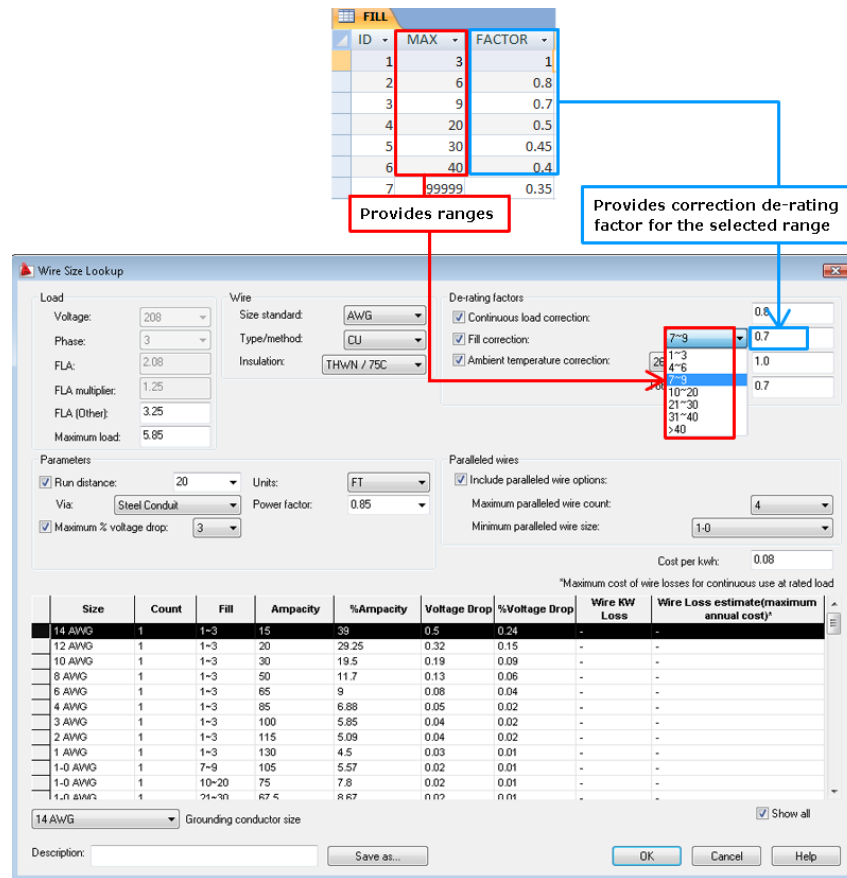

### MOTOR\_I\* tables

A set of three tables containing values used for calculating suggested breaker size, fuse size, and disconnect switch ratings for a given motor or load amp value. Each table name can have an optional suffix to relate it to a specific electrical standards code such as “\_NEC” for National Electrical Code.

### MOTOR\_I\_DESC

Lists the component type descriptions whose sizing ties directly into the full load amps value (FLA) of the motor or load. The CODE value maps to the MOTOR\_I\_CALC and MOTOR\_I\_MAP tables.

## MOTOR\_I\_CALC

Lists the formula to calculate the maximum amp value for various types of components on a per motor type basis. Each row gives a motor type followed by columns marked with the codes given in the MOTOR\_I\_DESC table. Each cell contains an expression to calculate a FLA value. The FLA value for the selected motor corresponds to the symbol "I" in the expression.

Valid operations are +, \*, /, ^. The “^” character is the exponential function. For example, I^2 is I squared, while I^0.5 is the square root of I.

If-then-else statements are supported including one level of nested statements. For example,

- (if (I > 400) then (I \* 8) else (I \* 11)) - the calculated amp value is eight times FLA current for 0-400 amps and 11 times for greater than FLA of 400 amps. One level of nesting is supported.
- (if (I >= 9.0) then (I \* 1.25) else if (I < 2.0) then (I \* 3.0) else (I \* 1.67)) - the calculated value is set to (I \* 1.67) if I is less than 9 but greater or equal to 2.0 amps. If I is less than 2.0 amps the calculated value is (I \* 3.0), and if greater than or equal to 9.0 amps, it is (I \* 1.25).

Valid Boolean operations are >, <, >=, <=, =.

## MOTOR\_I\_MAP

Maps the calculated FLA for a component to a specific rating value and an optional catalog assignment. The rating value is annotated to the symbol using the API call c:ace\_cb\_anno2 in the circuit builder spreadsheet.

The optional catalog assignment is defined in the Default field. Use the following format:

MFG={manufacturer};CAT={catalog};ASSYCODE={assembly code}

If the ASSYCODE value is not needed, use the format:

MFG={manufacturer};CAT={catalog}

## CATALOGSEL table

Circuit Builder uses the CATALOGSEL table to save the catalog selections made for the motor and other components. The catalog information is saved based on the motor size. If this same motor size is used later on another circuit, these previous catalog selections become the default values when they match up with the configured selections. For example, if the previous circuit was configured with a 10HP motor with time-delay fuses, and a 10HP motor with

time-delay fuses is selected for the new circuit, the previously used catalog selection appears as the default.

If the circuit is configured using the [Reference an existing circuit](#) on page 721 feature, the values are not used from the CATALOGSEL table but from the referenced circuit. However, if a new motor is then selected from the [Select Motor](#) on page 710 dialog box, the CATALOGSEL tables values are checked for a match.

## Electrical standards database editor

The electrical standards database editor provides these basic functions to modify the electrical standards database file.

- Open a table
- Copy and paste a table
- Delete a table
- Edit the contents of a table

For additional capabilities, use Microsoft Access.

### See also:

- [Electrical standards database file](#) on page 663

### Open and close a table

- 1 Click Schematic tab ► Other Tools panel ►  ► Database Editors drop-down ►  ► Electrical Standards Database Editor.
- 2 Expand the tree list on the left-hand side of the dialog box.
- 3 Select the table you want to open.
- 4 Right-click and select Open on the context menu.

---

**NOTE** You can also double-click a table name to open it.

---

- 5 To close a table, move the mouse over the tab for the table. An X is displayed. Click the X.
- 6 Select Yes to save the changes if prompted.

## Copy and paste a table

- 1 Click Schematic tab ► Other Tools panel ►  ► Database Editors drop-down ►  Electrical Standards Database Editor.
- 2 Expand the tree list on the left-hand side of the dialog box.
- 3 Select the table you want to copy and paste.

---

**NOTE** Use the shift or ctrl keys to select multiple tables.

---



- 4 Right click and select Copy on the context menu.
- 5 Right click again and select Paste.  
The Copying Table dialog box displays.
- 6 Enter the name for the new table. If multiple tables were selected to copy, enter a name for each table as prompted.  
To paste a table into a different electrical standard, add the appropriate suffix to the table name. For example, if you want to paste the default OPT table to the NEC standard, enter the name OPT\_NEC. If the NEC standard does not exist in the database file, it is created.

---

**NOTE** See [Electrical standards database file](#) on page 663 for table naming rules.

---

## Delete a table

- 1 Click Schematic tab ► Other Tools panel ►  ► Database Editors drop-down ►  Electrical Standards Database Editor.

- 2 Expand the tree list on the left-hand side of the dialog box.
- 3 Select the table you want to delete.

---

**NOTE** Use the shift or ctrl keys to select multiple tables.

---

- 4 Right click and select Delete on the context menu.  
The Delete Tables task dialog displays.
- 5 Click Yes.

---

**NOTE** This change is written to the database file immediately and cannot be canceled or undone.

---

### Edit a table

- 1 Click Schematic tab ► Other Tools panel ►  ► Database Editors

drop-down ► Electrical Standards Database Editor. 

- 2 Expand the tree list on the left-hand side of the dialog box.
- 3 Select the table you want to open.
- 4 Right-click and select Open on the context menu.

---

**NOTE** You can also double-click a table name to open it.

---

### Edit contents

- 1 Click the cell to edit and type to overwrite the contents.  
Double-click the cell to edit the contents.
- 2 Click Save.

### Add a record

- 1 Click to the left of a row to highlight a row.
- 2 Right-click to display the context menu.
- 3 Click Add New Record.

The new record is added at the end of the table.

- 4 Enter values in each cell of the new row.
- 5 Click Save.

#### **Delete a record**

- 1 Click to the left of a row to highlight a row.
- 2 Right-click to display the context menu.
- 3 Click Delete Record.
- 4 Click Save.

#### **Copy and paste**

- 1 Click to the left of a row to highlight a row.
- 2 Right-click to display the context menu.
- 3 Click Copy.  
The contents of the row are placed in memory.
- 4 Right-click to display the context menu.
- 5 Click Paste.  
The copied record is added at the end of the table.
- 6 Edit the contents of the cells.
- 7 Click Save.

#### **Add a column**

- 1 Click a column label.
- 2 Right-click to display the context menu.
- 3 Click Insert Column.  
The Insert Column dialog box displays.
- 4 Enter a name for the column.
- 5 Select the column type, Text, or Number.
- 6 Click OK.  
The column is added at the end.



7 Enter the cell values.

8 Click Save.

---

**NOTE** Columns can only be added to the AMP, INSUL, MOTOR\_I\_CALC, and XL&R tables.

---

### Delete a column

1 Click a column label.

2 Right-click to display the context menu.

3 Click Delete Column.

The Delete Column task dialog displays.

4 Click Yes.

---

**NOTE** This change is written to the database file immediately and cannot be canceled or undone.

---

---

**NOTE** Columns can only be deleted from the AMP, INSUL, MOTOR\_I\_CALC, and XL&R tables.

---

### Sorting

➤ Double-click a column to sort by the contents of that column.

---

**NOTE** Sorting is temporary and is not saved to the file.

---

## Electrical standards database editor

Edits the electrical standards database file.

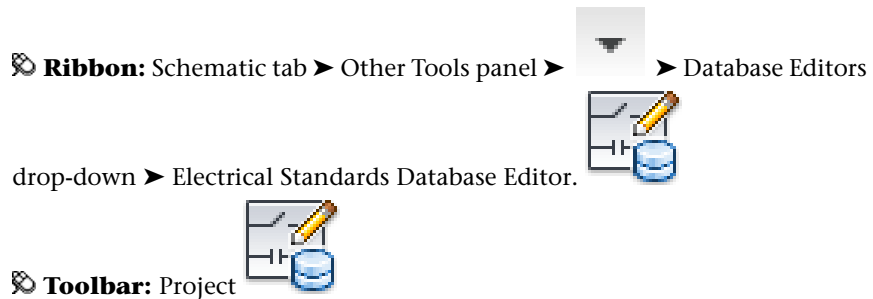

 **Menu:** Projects ► Extras ► Electrical Standards Database Editor  
 **Command entry:** AEDBEDITOR

### Tree structure

The left-hand side lists the existing tables in a tree structure. The highest level is separated by electrical standard as defined by the table suffix. Any tables without a suffix are listed under Default. A right-click context menu is available for the following functions.

<b>Open</b>	Select a table, right-click, and select Open. Double-click the table name to open.
<b>Delete</b>	Select a table, right-click, and select Delete. Use the Shift and Ctrl keys to select multiple tables to delete.
<b>Copy</b>	Select a table, right-click, and select Copy. Use the Shift and Ctrl keys to select multiple tables to delete.
<b>Paste</b>	Right-click and select Paste. Enter the new table name. If multiple tables were copied, you are prompted for each table name. Enter a new suffix to create a new electrical standard level.

### Table

The right-hand side displays the content of a table for modifying.

<b>Close the table</b>	Move the mouse to the tab for the table. Click the X.
<b>Cut</b>	Click to the left of a row to highlight a row. Right-click and select Cut. Use the Shift and Ctrl keys, or drag the mouse, to select multiple records to cut.
<b>Copy</b>	Click to the left of a row to highlight a row. Right-click and select Copy. Use the Shift and Ctrl keys, or drag the mouse, to select multiple records to copy.
<b>Paste</b>	After cutting or copying, right-click and select Paste. The records are appended to the end of the table.
<b>Add New Record</b>	Right-click to the left of a row and select Add New Record. A blank record is appended to the end of the table.

<b>Delete Record</b>	Click to the left of a row to highlight a row. Right-click and select Delete Record.
<b>Edit contents</b>	Click the cell to edit. Type to overwrite the contents. Double-click the cell to edit the contents.
<b>Insert Column</b>	Place the mouse over a column label. Right-click and select Insert Column. A blank column is appended to the table. <hr/> <b>NOTE</b> Columns can only be added to the AMP, INSUL, MOTOR_I_CALC, and XL&R tables. <hr/>
<b>Delete Column</b>	Click the column label. Right-click and select Delete Column. <hr/> <b>NOTE</b> Columns can only be deleted from the AMP, INSUL, MOTOR_I_CALC, and XL&R tables. <hr/>
<b>Sort</b>	Double-click a column label to sort the table by the values in that column. <hr/> <b>NOTE</b> The sorted order is not saved to the database file. <hr/>
<b>Save</b>	Select the Save button to save all open and modified tables. Select Save Current to save the current or only open table. Select Save All to save changes on all open tables.
<b>Close</b>	Select the Close button to exit the editor. The Close dialog displays for each open and modified table prompting you to save the changes for that table.

## Use Circuit Builder

The Circuit Builder tool comes prepopulated with data to build and annotate a sampling of motor control circuits and power feed circuits. It includes three-phase, single-phase, and one-line circuit representations. Each circuit is built dynamically with the following features:

- Connects to an adjacent power bus.
- Adds wiring between components.
- Annotates selected components with suggested values based upon the selected load.

Each time a circuit is configured, it is added to a history list of circuits. This list provides for quick re-insertion at a later time.

You can [customize](#) on page 2005 Circuit Builder to insert other circuit types.

### One-line motor control

Circuit Build supplies and uses a one-line symbol library when building a one-line circuit. Each one-line symbol has a [WDTYPE attribute](#) on page 325 with a value of “1-” or “1-1”. The WDTYPE attribute value distinguishes the one-line symbol from a schematic symbol. A schematic symbol either has no WDTYPE attribute or a blank WDTYPE attribute value. One-line symbols follow the same [symbol naming](#) on page 288 conventions and have the same [attribute requirements](#) on page 326 as schematic symbols with a few attribute exceptions.

Attribute	Description
WDTYPE	The attribute must be present and carry a value of “1-” to indicate it is a one-line symbol, or “1-1” for the one-line bus-tap symbols. A bus-tap symbol is used to mark the beginning of a one-line circuit. Schematic symbols do not carry this attribute or have the attribute but with a blank value.
RATING1	Omitted from one-line cable markers symbols since a one-line cable marker can represent multiple conductors, multiple wires, or core color assignments.
TERM01	Omitted from one-line terminal symbols since a one-line terminal can represent multiple independent terminals. If a TERM01 attribute is added to a one-line symbol and carries a non-blank value, it can be edited in the Insert/Edit Terminal Symbol dialog box. However, terminal number text on one-line terminal symbols is not linked back to terminal number assignments on schematic or panel terminal representations.

---

**NOTE** One-line terminals are not processed by Terminal Strip Editor.

### Insert a 3-phase circuit

Builds a circuit based on your selection from a list of available circuits and circuit elements.

The circuit builds dynamically and matches the rung spacing, adds wiring between components, and can annotate the circuit with calculated values based upon the assigned load amperage of the circuit. Circuit Builder extracts

these annotation values from a database based on engineering standards, motor horsepower, and supply voltage.

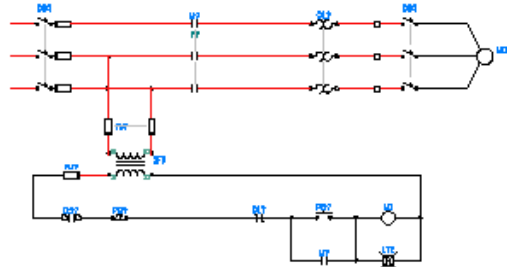

- 1 Click Schematic tab ► Insert Components panel ► Circuit Builder



drop-down ► Circuit Builder.

- 2 Select the circuit from the Circuits list. For example:

**Circuits:** 3ph Motor Circuit, Horizontal - FVNR - non reversing

---

**NOTE** You can also select History to display the list of previously configured circuits.

---

A circuit inserted from the Circuits list contains all default circuit elements as defined in the circuit template and circuit builder spreadsheet. See [Set circuit element defaults](#) on page 2075 to change the default circuit setup.

A circuit inserted from the History list contains all circuit elements and values of the previously [configured](#) on page 690 circuit.

- 3 (Optional) Enter a Circuit Scale. This value sets an insertion scale value for the circuit template drawing.
- 4 (Optional) Enter a Component Scale. This value sets an insertion scale value for the individual components inserted while building the circuit.
- 5 (Optional) Enter a Horizontal Rung Spacing.
- 6 (Optional) Enter a Vertical Rung Spacing.
- 7 (Optional) Select to apply some specific annotation:
  - [Presets](#) on page 2072 - defined in the ANNO\_CODE sheet of the Circuit Builder spreadsheet file that map to the selected circuit.

- [Reference an existing circuit](#) on page 723 - reference values from an existing circuit selected from a list of circuits extracted from the active project. The state of the Retag new components check box controls the retagging of the components within the new circuit. Values can include catalog assignment, component descriptions, annotation values, and more.

---

**NOTE** This option is not available if the circuit is selected from the History list.

---

- 8 Select Insert.
- 9 Select an insertion point location on the drawing.

### Configure a 3-phase circuit

- 1 Click Schematic tab ► Insert Components panel ► Circuit Builder



drop-down ► Circuit Builder.

- 2 Select the circuit from the Circuits list. For example:

**Circuits:** 3ph Motor Circuit, Horizontal - FVNR - non reversing

---

**NOTE** You can also select History to display the list of previously inserted circuits.

---

- 3 (Optional) Enter a Circuit Scale. This value sets an insertion scale value for the circuit template.
- 4 (Optional) Enter a Component Scale. This value sets an insertion scale value for the individual components inserted while building the circuit.
- 5 (Optional) Enter a Horizontal Rung Spacing.
- 6 (Optional) Enter a Vertical Rung Spacing.
- 7 (Optional) Select to apply some specific annotation:
  - [Presets](#) on page 2072 - defined in the ANNO\_CODE sheet of the Circuit Builder spreadsheet file that map to the selected circuit.
  - [Reference an existing circuit](#) on page 723 - reference values from an existing circuit selected from a list of circuits extracted from the active project. The state of the Retag new components check box controls

the retagging of the components within the new circuit. Values can include catalog assignment, component descriptions, annotation values, and more.

---

**NOTE** This option is not available if the circuit is selected from the History list.

---

- 8 Select Configure.
- 9 Select an insertion point location on the drawing. The template drawing for the selected circuit is inserted at the specified location. The template drawing contains marker blocks. Each block is marked with a code value that links to instructions for either inserting a component, wire number, or adjusting the wiring of the circuit.

The dialog box has three sections, Circuit Elements, Select, and Setup & Annotations. The options differ depending on the circuit and circuit element selected.

- 10 Select a circuit element, for example:

**Circuit Elements:** Motor Setup



- 11 Click the Motor Setup Browse button to display the Select Motor dialog box. This dialog box is where you select the motor and horsepower or KW size from the electrical standards database. For other components, the Catalog lookup dialog box displays. You can also type in values for each entry.



- 12 Click the Wire Setup Browse button to display the Wire Size Lookup dialog box. This dialog box is where you select or adjust the wire size based on an analysis of the load and various installation parameters. You can also type in values for each entry.

- 13 Select a circuit element, for example:

**Circuit Elements:** Disconnecting means

The options for this circuit element, defined in the circuit builder spreadsheet, are displayed in the Select section.

- 14 Select the options for this circuit element, for example:

**Main Disconnect:** Circuit breaker

**Include N.O. auxiliary contact:** Yes

- 15 (Optional) Modify values in the Setup & Annotations section for the selected circuit element.

---

**NOTE** Depending upon how this circuit element is set up in the circuit builder spreadsheet, this section may not be available for circuit element modification.

---



Select the Browse button to make a part number assignment from the Catalog lookup dialog box. The “TABLE” entry defines the catalog lookup table for the component in the circuit builder spreadsheet. You can also type in values for each entry.

- 16 Repeat to configure each circuit element.
- 17 (Optional) Enter a name for the circuit. This name is added to the History list on the Circuit Selection dialog box and makes it easier to find this same circuit for future re-insertion.
- 18 Select from one of three ways to insert the circuit elements.



Click to insert just the highlighted circuit element.



Click to insert all the circuit elements up to and including the highlighted circuit element.



Click to insert all the circuit elements.

---

**NOTE** If the circuit contains a nested template, the circuit elements tree structure may expand when the nested circuit is inserted into the overall circuit. You may need to go back and configure the circuit elements that are part of the nested template.

---

- 19 Select Done. The circuit is finalized by:
  - Remaining untagged child components are matched up with parent components and tags are assigned.



- The selection information for the circuit is applied to the main component of the circuit, for example the motor or load symbol.
- The remaining marker blocks are removed from the circuit template for any circuit elements not inserted.

---

**NOTE** The Circuit Elements list is built dynamically based on the template for the selected circuit. As the circuit elements are inserted, if the element contains a nested circuit, the circuit element becomes expandable so you can configure the nested circuit elements.

---

## Insert a power feed circuit

- 1 Click Schematic tab ► Insert Components panel ► Circuit Builder



drop-down ► Circuit Builder.

- 2 Select the power feed circuit. For example:  
**Circuits:** 3ph Power Feed, Horizontal - Single feed

---

**NOTE** You can also select History to display the list of previously inserted circuits.

---

A circuit inserted from the Circuits list contains all default circuit elements as defined in the circuit template and circuit builder spreadsheet. See [Customize Circuit Builder](#) on page 2005 to change the default circuit setup.

A circuit inserted from the History list contains all circuit elements and values of the previously inserted circuit.

- 3 (Optional) Enter a Circuit Scale. This value sets an insertion scale value for the circuit template.
- 4 (Optional) Enter a Component Scale. This value sets an insertion scale value for the individual components inserted while building the circuit.
- 5 (Optional) Enter a Horizontal Rung Spacing.
- 6 (Optional) Enter a Vertical Rung Spacing.
- 7 (Optional) Select to apply some specific annotation:
  - [Presets](#) on page 2072 - defined in the ANNO\_CODE sheet of the Circuit Builder spreadsheet file that map to the selected circuit.

- [Reference an existing circuit](#) on page 723 - reference values from an existing circuit selected from a list of circuits extracted from the active project. The state of the Retag new components check box controls the retagging of the components within the new circuit. Values can include catalog assignment, component descriptions, annotation values, and more.

---

**NOTE** This option is not available if the circuit is selected from the History list.

---

- 8 Select Insert.
- 9 Select an insertion point location on the drawing.

## Configure a power feed circuit

- 1 Click Schematic tab ► Insert Components panel ► Circuit Builder



drop-down ► Circuit Builder.

- 2 Select the circuit from the Circuits list. For example:

**Circuits:** 3ph Power Feed, Horizontal - Single feed.

---

**NOTE** You can also select History to display the list of previously inserted circuits.

---

- 3 (Optional) Enter a Circuit Scale. This value sets an insertion scale value for the circuit template.
- 4 (Optional) Enter a Component Scale. This value sets an insertion scale value for the individual components inserted while building the circuit.
- 5 (Optional) Enter a Horizontal Rung Spacing.
- 6 (Optional) Enter a Vertical Rung Spacing.
- 7 (Optional) Select to apply some specific annotation:
  - [Presets](#) on page 2072 - defined in the ANNO\_CODE sheet of the Circuit Builder spreadsheet file that map to the selected circuit.
  - [Reference an existing circuit](#) on page 723 - reference values from an existing circuit selected from a list of circuits extracted from the active project. The state of the Retag new components check box controls

the retagging of the components within the new circuit. Values can include catalog assignment, component descriptions, annotation values, and more.

---

**NOTE** This option is not available if the circuit is selected from the History list.

---

- 8 Select Configure.
- 9 Select an insertion point location on the drawing. The template drawing for the power feed is inserted at the specified location. The template drawing contains marker blocks, with instructions for building the circuit, and the circuit wiring.

The dialog box has three sections, Circuit Elements, Select, and Setup & Annotations. The options differ depending on the circuit selected.

- 10 Select a circuit element, for example:

**Circuit Elements:** Load

The options for this circuit element, driven from the circuit builder spreadsheet, are displayed in the Select section.

- 11 Select the option for this circuit element, for example:

**Load:** Generic box

- 12 Select another circuit element, for example:

**Circuit Elements:** Load Setup



- 13 Click the Load Setup Browse button to display the Select Load dialog box. This dialog box is where you select the load from the electrical standards database. For other components, the Catalog lookup dialog box displays. You can also type in values for each entry.



- 14 Click the Wire Setup Browse button to display the Wire Size Lookup dialog box. This dialog box is where you select or adjust the wire size based on an analysis of the load and various installation parameters. You can also type in values for each entry.

- 15 Repeat to configure each circuit element.

- 16** (Optional) Enter a name for the circuit. This name is added to the History list on the Circuit Selection dialog box and makes it easier to find for future re-insertion.
- 17** Select from one of three ways to insert the circuit elements.



Click to insert just the highlighted circuit element.



Click to insert all the circuit elements up to and including the highlighted circuit element.



Click to insert all the circuit elements.

---

**NOTE** If the circuit contains a nested template, go back and configure the circuit elements in the nested template.

---

- 18** Select Done. The circuit is finalized by:
- Remaining untagged child components are matched up with parent components and tags are assigned.
  - The selection information for the circuit is applied to the main component of the circuit.
  - The remaining marker blocks are removed from the circuit template for any circuit elements not inserted.

## Configure a dual power feed circuit

A dual power feed circuit has two distinct circuits running off the same bus-tap. Each circuit can be independently configured.

- 1** Click Schematic tab ► Insert Components panel ► Circuit Builder



drop-down ► Circuit Builder.

2 Select the circuit from the Circuits list. For example:

**Circuits:** 3ph Power Feed, Horizontal - Dual feed.

---

**NOTE** You can also select History to display the list of previously inserted circuits.

---

3 (Optional) Enter a Circuit Scale. This value sets an insertion scale value for the circuit template.

4 (Optional) Enter a Component Scale. This value sets an insertion scale value for the individual components inserted while building the circuit.

5 (Optional) Enter a Horizontal Rung Spacing.

6 (Optional) Enter a Vertical Rung Spacing.

7 (Optional) Select to apply some specific annotation:

- [Presets](#) on page 2072 - defined in the ANNO\_CODE sheet of the Circuit Builder spreadsheet file that map to the selected circuit.

- [Reference an existing circuit](#) on page 723 - reference values from an existing circuit selected from a list of circuits extracted from the active project. The Retag new components check box controls the retagging of the components. Values can include catalog assignment, component descriptions, annotation values, and more.

---

**NOTE** This option is not available if the circuit is selected from the History list.

---

8 Select Configure.

9 Select an insertion point location on the drawing. The template drawing for the dual power feed is inserted at the specified location. The template drawing contains marker blocks, with instructions for building the circuit, and the circuit wiring.

The dialog box has three sections, Circuit Elements, Select, and Setup & Annotations. The options differ depending on the circuit selected.

---

**NOTE** The circuit elements with a "(2)" prefix make up the second circuit.

---

10 Select a circuit element, for example:

**Circuit Elements:** Load

The options for this circuit element, driven from the circuit builder spreadsheet, are displayed in the Select section.

- 11 Select the option for this circuit element, for example:

**Load:** Generic box

- 12 Select another circuit element, for example:

**Circuit Elements:** Load Setup

- 13  Click the Load Setup Browse button to display the Select Load dialog box. This dialog box is where you select the load from the electrical standards database. For other components, the Catalog lookup dialog box displays. You can also type in values for each entry.

- 14  Click the Wire Setup Browse button to display the Wire Size Lookup dialog box. This dialog box is where you select or adjust the wire size based on an analysis of the load and various installation parameters. You can also type in values for each entry.

- 15 Repeat to configure each circuit element including the ones with the “(2)” prefix indicating they are part of the second circuit.

- 16 (Optional) Enter a name for the circuit. This name is added to the History list on the Circuit Selection dialog box and makes it easier to find for future re-insertion.

- 17 Select from one of three ways to insert the circuit elements.



Click to insert just the highlighted circuit element.



Click to insert all the circuit elements up to and including the highlighted circuit element.



Click to insert all the circuit elements.

---

**NOTE** If the circuit contains a nested template you, go back and configure the circuit elements in the nested template.

---

- 18** Select Done. The circuit is finalized by:
- Remaining untagged child components are matched up with parent components and tags are assigned.
  - The selection information for the circuit is applied to the main component of the circuit.
  - The remaining marker blocks are removed from the circuit template for any circuit elements not inserted.

## Insert a one-line circuit

Builds a one-line circuit based on your selection from a list of available circuits and circuit elements.

Circuit Builder builds the circuit dynamically and annotates the circuit. Annotation values are extracted from a database based on engineering standards, motor horsepower, and supply voltage.

---

**NOTE** Add the one-line library [search path](#) on page 204 to the project so Circuit Builder can find the one-line circuit templates. By default, the one-line library is installed in a *1*- folder under the schematic library folder.

---

- 1** Click Schematic tab ► Insert Components panel ► Circuit Builder



drop-down ► Circuit Builder.

- 2** Select a one-line circuit from the Circuits list. For example:  
**Circuits:** One-line Motor Circuit, Vertical - FVNR - non reversing.

---

**NOTE** You can also select History to display the list of previously inserted circuits.

---

- 3** (Optional) Enter a Circuit Scale. This value sets an insertion scale value for the circuit template.
- 4** (Optional) Enter a Component Scale. This value sets an insertion scale value for the individual components inserted while building the circuit.

- 5 (Optional) Select to apply some specific annotation:
  - [Presets](#) on page 2072 - defined in the ANNO\_CODE sheet of the Circuit Builder spreadsheet file that map to the selected circuit.
  - [Reference an existing circuit](#) on page 723 - reference values from an existing circuit selected from a list of circuits extracted from the active project. The state of the Retag new components check box controls the retagging of the components within the new circuit. Values can include catalog assignment, component descriptions, annotation values, and more.

---

**NOTE** This option is not available if the circuit is selected from the History list.

---

- 6 Select Insert.

A circuit inserted from the Circuits list contains all default circuit elements as defined in the circuit template and circuit builder spreadsheet. See [Set circuit element defaults](#) on page 2075 to change default circuit setup.
- 7 Select an insertion point location on the drawing.

## Configure a one-line circuit

Configures and builds a one-line circuit based on your selection from a list of available circuits and circuit elements.

---

**NOTE** Add the one-line library [search path](#) on page 204 to the project so Circuit Builder can find the one-line circuit templates. By default, the one-line library is installed in a 1- folder under the schematic library folder.

---

- 1 Click Schematic tab ► Insert Components panel ► Circuit Builder



drop-down ► Circuit Builder.

- 2 Select the circuit from the Circuits list. For example:  
**Circuits:** One-line Motor Circuit, Vertical - FVNR - non reversing

---

**NOTE** You can also select History to display the list of previously inserted circuits.

---



- 3 (Optional) Enter a Circuit Scale. This value sets an insertion scale value for the circuit template.
- 4 (Optional) Enter a Component Scale. This value sets an insertion scale value for the individual components inserted while building the circuit.
- 5 (Optional) Select to apply some specific annotation:
  - [Presets](#) on page 2072 - defined in the ANNO\_CODE sheet of the Circuit Builder spreadsheet file that map to the selected circuit.
  - [Reference an existing circuit](#) on page 723 - reference values from an existing circuit selected from a list of circuits extracted from the active project. The state of the Retag new components controls the retagging of the components within the new circuit. Values can include catalog assignment, component descriptions, annotation values, and more.

---

**NOTE** This option is not available if the circuit is selected from the History list.

---

- 6 Select Configure.
- 7 Select an insertion point location on the drawing. The template drawing for the selected circuit is inserted at the specified location. The template drawing contains marker blocks, with instructions for building the circuit, and the circuit wiring.

The dialog box has three sections, Circuit Elements, Select, and Setup & Annotations. The options differ depending on the circuit and circuit element selected.

- 8 Select a circuit element, for example:

**Circuit Elements:** Motor Setup



- 9 Click the Motor Setup Browse button to display the Select Motor dialog box. This dialog box is where you select the motor and horsepower or KW size from the electrical standards database. For other components, the Catalog lookup dialog box displays. You can also type in values for each entry.



- 10 Click the Wire Setup Browse button to display the Wire Size Lookup dialog box. This dialog box is where you select or adjust the wire size

based on an analysis of the load and various installation parameters. You can also type in values for each entry.

- 11 Select a circuit element, for example:

**Circuit Elements:** Disconnecting means

The options for this circuit element, defined in the circuit builder spreadsheet, are displayed in the Select section.

- 12 Select the options for this circuit element, for example:

**Main Disconnect:** Disconnect switch and fuses

- 13 (Optional) Modify values in the Setup & Annotations section for the selected circuit element.

---

**NOTE** Depending upon how this circuit element is set up in the circuit builder spreadsheet, this section may not be available for circuit element modification.

---



Select the Browse button to make a part number assignment from the Catalog lookup dialog box. The “TABLE” entry for the component in the circuit builder spreadsheet defines the catalog lookup table. You can also type in values for each entry.

- 14 Repeat to configure each circuit element.
- 15 (Optional) Enter a name for the circuit. This name is added to the History list on the Circuit Selection dialog box and makes it easier to find for future re-insertion.
- 16 Select from one of three ways to insert the circuit elements.



Click to insert just the highlighted circuit element.



Click to insert all the circuit elements up to and including the highlighted circuit element.



Click to insert all the circuit elements.

---

**NOTE** If the circuit contains a nested template, go back and configure the circuit elements in the nested template.

---

- 17 Select Done. The circuit is finalized by:
  - Remaining untagged child components are matched up with parent components and tags are assigned.
  - The selection information for the circuit is applied to the main component of the circuit.
  - The remaining marker blocks are removed from the circuit template for any circuit elements not inserted.

## Configure a dual one-line circuit

---

**NOTE** Add the one-line library [search path](#) on page 204 to the project so Circuit Builder can find the one-line circuit templates. By default, the one-line library is installed in a 1- folder under the schematic library folder.

---

- 1 Click Schematic tab ► Insert Components panel ► Circuit Builder



drop-down ► Circuit Builder.

- 2 Select the circuit from the Circuits list. For example:  
**Circuits:** One-line Motor Circuit, Vertical - Dual FVNR - non reversing

---

**NOTE** You can also select History to display the list of previously inserted circuits.

---

- 3 (Optional) Enter a Circuit Scale. This value sets an insertion scale value for the circuit template.
- 4 (Optional) Enter a Component Scale. This value sets an insertion scale value for the individual components inserted while building the circuit.

- 5 (Optional) Select to apply some specific annotation:
  - [Presets](#) on page 2072 - defined in the ANNO\_CODE sheet of the Circuit Builder spreadsheet file that map to the selected circuit.
  - [Reference an existing circuit](#) on page 723 - reference values from an existing circuit selected from a list of circuits extracted from the active project. The state of the Retag new components controls the retagging of the components within the new circuit. Values can include catalog assignment, component descriptions, annotation values, and more.

---

**NOTE** This option is not available if the circuit is selected from the History list.

---

- 6 Select Configure.
- 7 Select an insertion point location on the drawing. The template drawing for the selected circuit is inserted at the specified location. The template drawing contains marker blocks, with instructions for building the circuit, and the circuit wiring.

The dialog box has three sections, Circuit Elements, Select, and Setup & Annotations. The options differ depending on the circuit and circuit element selected.



---

**NOTE** The circuit elements with a "(2)" prefix make up the second circuit.

---

- 8 Select a circuit element, for example:

**Circuit Elements:** Motor Setup

- 9  Click the Motor Setup Browse button to display the Select Motor dialog box. This dialog box is where you select the motor and horsepower or KW size from the electrical standards database. For other components, the Catalog lookup dialog box displays. You can also type in values for each entry.
- 10  Select the Wire Setup Browse button to display the Wire Size Lookup dialog box. This dialog box is where you select or adjust the wire size based on an analysis of the load and various installation parameters. You can also type in values for each entry.
- 11 Select a circuit element, for example:

**Circuit Elements:** Disconnecting means

The options for this circuit element, defined in the circuit builder spreadsheet, are displayed in the Select section.

- 12 Select the options for this circuit element, for example:

**Main Disconnect:** Disconnect switch and fuses

- 13 (Optional) Modify values in the Setup & Annotations section for the selected circuit element.

---

**NOTE** Depending upon how this circuit element is set up in the circuit builder spreadsheet, this section may not be available for circuit element modification.

---



Select the Browse button to make a part number assignment from the Catalog lookup dialog box. The “TABLE” entry for the component in the circuit builder spreadsheet defines the catalog lookup table. You can also type in values for each entry.

- 14 Repeat to configure each circuit element including the ones with the “(2)” prefix indicating they are part of the second circuit.
- 15 (Optional) Enter a name for the circuit. This name is added to the History list on the Circuit Selection dialog box for future insertion.
- 16 Select from one of three ways to insert the circuit elements.



Click to insert just the highlighted circuit element.



Click to insert all the circuit elements up to and including the highlighted circuit element.



Click to insert all the circuit elements.

---

**NOTE** If the circuit contains a nested template, go back and configure the circuit elements in the nested template.

---

- 17 Select Done. The marker blocks are removed from the circuit template for any circuit elements not inserted.

## Circuit Selection

Select to insert a circuit. A circuit is built based on a circuit template assigned to the selected circuit type. The rung spacing of the circuit adjusts to match the rung spacing setting for the drawing ([Drawing properties: drawing format tab](#) on page 231). Each individual device is inserted at a location predefined on the circuit template. Devices are annotated based on values in the Circuit Builder spreadsheet. The spreadsheet file name is displayed near the top of the Circuit Selection dialog box.

 **Ribbon:** Schematic tab ► Insert Components panel ► Circuit Builder



drop-down ► Circuit Builder.



 **Toolbar:** Main Electrical

 **Menu:** Components ► Circuit Builder

 **Command entry:** AECIRCBUILDER

<b>Circuits</b>	<p>The tree structure is created by reading the ACE_CIRCS sheet of the circuit builder spreadsheet and constructing the tree from the data found in columns CATEGORY and TYPE. The default spreadsheet file is ace_circuit_builder.xls.</p> <p>The tree has two levels. The first level is the circuit category, for example 3-phase Motor Circuit. The second level is the circuit type, for example Horizontal - Full Voltage Non-reversing.</p>
<b>History&gt;&gt;</b>	Expands the dialog box to show the history of configured and inserted circuits.
<b>History&lt;&lt;</b>	Collapses the dialog box to hide the history of configured and inserted circuits.
<b>History</b>	Select a previously inserted circuit, including all annotation values, to insert or configure. Select a circuit from this history list and then select Insert or Configure. Select Delete to remove the displayed circuit from the history listing.

---

**NOTE** This option is not available if Reference existing circuit is selected.

---

<b>Circuit Scale</b>	Sets an insertion scale value for the entire template.
<b>Component Scale</b>	Sets an insertion scale value for the individual components inserted while building the circuit.
<b>Horizontal Rung Spacing</b>	Sets the 3-phase horizontal rung spacing for the circuit. The ladder rung spacing for the drawing is the default value.
<b>Vertical Rung Spacing</b>	Sets the 3-phase vertical rung spacing for the circuit. The multi-wire spacing for the drawing is the default value.
<b>None</b>	Specifies to ignore special annotation options.
<b>Presets</b>	Specifies whether to use the preset annotation values from the circuit builder spreadsheet.
<b>Presets - List</b>	Displays the Annotation dialog box. Use this dialog box to specify which annotation values from the spreadsheet ANNO_CODE sheet to apply.
<b>Reference existing circuit</b>	Specifies whether to use annotation values from an existing circuit.
	<b>NOTE</b> This option is not available if the circuit is selected from the history list. Select <Default> from the History list to re-enable the Reference existing circuit option.
<b>Reference existing circuit - List</b>	Displays the Existing Circuits dialog box showing the existing circuits found in the active project. Select a circuit from the list. The values from the selected circuit are applied to the new circuit.
<b>Retag new components</b>	When Reference existing circuit is selected, specifies whether to retag the components inserted as part of the new circuit.
<b>Insert</b>	Inserts the circuit with all default circuit elements and settings.

**Configure** Opens the Circuit Configuration dialog box. Modify the options for the circuit and insert it.

## Annotation Presets

Predefine component attribute values in the [ANNO\\_CODE](#) on page 2072 sheet of the Circuit Builder spreadsheet file. The values are applied to the components when the circuit is inserted.

**Selection grid** Specifies which preset annotation values to apply. Double click to edit a value. Highlight a row before selecting Drawing or Project to display a dialog with a list of used values for the attribute.

**Clear all** Clears all selections.

**Drawing** Displays a dialog box with a list of values used on the active drawing for the highlighted attribute.

**Project** Displays a dialog box with a list of values used within the project for the highlighted attribute.

## Circuit Configuration

This dialog box provides options to configure a circuit before inserting it. You can configure the circuit both in terms of the physical devices and the device annotation values.

 **Ribbon:** Schematic tab ► Insert Components panel ► Circuit Builder

drop-down ► Circuit Builder. 



 **Toolbar:** Main Electrical

 **Menu:** Components ► Circuit Builder

 **Command entry:** AECIRCBUILDER

On the Select Circuit dialog box, select a circuit and click Configure.

**Name** Enter a name for the circuit. This name is added to the History list on the Circuit Selection dialog box for future insertion.



**Circuit Elements**

Displays the circuit elements for the selected circuit for configuring. The tree structure is created dynamically based on the circuit template. Select a circuit element to configure it.

**Select**

Select the options for the highlighted circuit element.

---

**NOTE** The displayed options, along with default values, are defined in the circuit builder spreadsheet.

---

**Setup & Annotation**

Enter device annotation values, rung spacing, and wire type for the circuit.

---

**NOTE** The displayed values for the circuit are based on a motor or load lookup in the electrical standards database.

---



Inserts only the highlighted circuit element.



Inserts all the circuit elements up to and including the highlighted circuit element.



Inserts all the circuit elements.



Reverses the most recently inserted circuit element.

**Motor or Load Setup**



Displays the Select Motor or Select Load dialog box. Use this dialog box to specify settings by selecting from a list of predefined parameters.

**Motor or Load Setup**

Temporarily closes the dialog box so that you can select an existing motor or power feed and reuse the existing values.



### Wire Setup



Displays the Wire Size Lookup dialog box. Use this dialog to select a wire size based on load and various other parameters.

## Select Motor

Browse the motor lookup table in the electrical standards database, ace\_electrical\_standards.mdb, and select the appropriate motor and annotation values. You can also modify the motor lookup table from this dialog box.

 **Ribbon:** Schematic tab ► Insert Components panel ► Circuit Builder



drop-down ► Circuit Builder.



 **Toolbar:** Main Electrical

 **Menu:** Components ► Circuit Builder

 **Command entry:** AECIRCBUILDER

On the Select Circuit dialog box, select a circuit, click Configure, and then select the Motor Setup Browse button.

<b>Type</b>	Filter the listing based on motor type. Select <All> from the list to turn off filtering for this field.
<b>Voltage (V)</b>	Filter the listing based on motor voltage. Select <All> from the list to turn off filtering for this field.
<b>Frequency (HZ)</b>	Filter the listing based on motor frequency. Select <All> from the list to turn off filtering for this field.
<b>Selection grid</b>	Select a motor to pass the values back to the Circuit Configuration dialog box.
<b>Edit or add records</b>	Specifies whether you can edit or select the values. Values you edit are written back to the electrical standards database file.



Temporarily closes the dialog box so that you can select an existing motor symbol and reuse the values from the motor.

**FLA**

Displays or sets the full load amps (FLA) value. The FLA value is multiplied by the FLA Multiplier value to calculate the Maximum load value.

**FLA multiplier**

Sets the multiplier factor. The FLA value is multiplied by this value to calculate the Maximum load value.

**Maximum load**

Displays the calculated maximum load based on the product of FLA and FLA multiplier.

---

**NOTE** The initial default values used for Voltage and the FLA multiplier are controlled from the active OPT table in the electrical standards database file.

---

## Select Load

Browse the load table, named FEED in the electrical standards database file, ace\_electrical\_standards.mdb, and select the appropriate load and annotation values. You can also modify the lookup table from this dialog box.

**Ribbon:** Schematic tab ► Insert Components panel ► Circuit Builder

drop-down ► Circuit Builder.



**Toolbar:** Main Electrical

**Menu:** Components ► Circuit Builder

**Command entry:** AECIRCBUILDER

On the Select Circuit dialog box, select a power feed circuit, click Configure, and then select the Load Setup Browse button.

**Type**

Filter the listing based on load type. Select <All> from the list to turn off filtering for this field.

**Voltage (V)**

Filter the listing based on voltage. Select <All> from the list to turn off filtering for this field.

<b>Phase</b>	Filter the listing based on phase. Select <All> from the list to turn off filtering for this field.
<b>Selection grid</b>	Select a load to pass the values back to the Circuit Configuration dialog box.
<b>Edit or add records</b>	Specifies whether you can edit or select the values. Values you edit are written back to the electrical standards database file.
	Temporarily closes the dialog box so that you can select an existing power feed load symbol and reuse its values.
<b>FLA</b>	Displays or sets the full load amps (FLA) value. The FLA value is multiplied by the FLA Multiplier value to calculate the Maximum load value.
<b>FLA multiplier</b>	Sets the multiplier factor. The FLA value is multiplied by this value to calculate the Maximum load value.
<b>Maximum load</b>	Displays the calculated maximum load based on the product of FLA and FLA multiplier.

---

**NOTE** The initial default values used for Voltage and the FLA multiplier are controlled from the active OPT table in the electrical standards database file.

---

## Wire Size Lookup

Specify the wire parameters and select a wire size from a list of wire sizes that meet or exceed the parameters. Estimated energy losses per wire size can provide valuable information in this selection.

 **Ribbon:** Schematic tab ► Insert Components panel ► Circuit Builder

drop-down ► Circuit Builder.



 **Toolbar:** Main Electrical

 **Menu:** Components ► Circuit Builder

 **Command entry:** AECIRCBUILDER



On the Select Circuit dialog box, select a circuit, click Configure, enter the Motor Setup parameters, and then select the Wire Setup Browse button.

## Load

<b>Voltage</b>	Sets the voltage for the wire conductor.
<b>Phase</b>	Sets the phase of the electrical power.
<b>FLA</b>	Sets the full load amps carried by the wire conductors.
<b>FLA multiplier</b>	Sets the value that is multiplied by the FLA value to calculate the maximum load for the wire conductors.
<b>Other</b>	Sets the amp value of any additional loads to be combined with the main motor or load and fed from this common branch circuit set of conductors. This value is added to the product of the FLA times FLA multiplier.
<b>Maximum load</b>	Displays the calculated maximum load for the conductors. It is based on the FLA (Other) value added to the product of the FLA times the FLA multiplier value.

---

**NOTE** Controls are disabled if the values are predefined on the Circuit Configuration dialog.

---

FLA **1** X FLA multiplier **2** + Other **3** = Maximum load **4**

Wire Size Lookup

<b>Load</b>	<b>Wire</b>	<b>Derating factors</b>
Voltage: 208	Size standard: AWG	<input checked="" type="checkbox"/> Continuous load correction: 0.8
Phase: 3	Type/method: CU	<input checked="" type="checkbox"/> Fill correction: 7-9 0.7
FLA: 2.08 <b>1</b>	Insulation: TBS / 90C	<input checked="" type="checkbox"/> Ambient temperature correction: 61-70C 0.58
FLA multiplier: 1.25 <b>2</b>		Total correction: 0.406
FLA (Other): 3.25 <b>3</b>		
Maximum load: 5.85 <b>4</b>		

## Wire

<b>Size standard</b>	Sets the wire standard. Directs Circuit Builder to use specific tables from the electrical standards database for that wire size standard. The available values are extracted from the electrical standards database table names.
----------------------	---

**Type/method** Sets the wire metal type. Directs Circuit Builder to use specific tables from the electrical standards database for that wire metal type. The available values are extracted from the electrical standards database table names.

**Insulation** Sets the wire insulation and temperature rating type. The available values are extracted from the electrical standards database file.

### **De-rating factors**

**Continuous load correction** Specifies whether to include a continuous load de-rating factor in the calculation of the wire ampacity. For example, continuous equals three hours or longer. When Continuous load correction is on, sets the de-rating factor. This value is used in the total de-rating factor used to calculate wire ampacity.

**Fill correction** Specifies whether to include a fill correction de-rating factor in the calculation of the wire ampacity. When Fill correction is on, sets the range of current carrying conductors that are grouped in a common conduit, raceway, or cable. When Fill correction is on, sets the de-rating factor for the selected fill range. This value is used in the total de-rating factor used to calculate wire ampacity.

**Ambient temperature correction** Specifies whether to use a de-rating factor for an elevated ambient temperature. When Ambient temperature correction is on, sets the range of maximum ambient temperature. When Ambient temperature correction is on, sets the correction factor value. This value is used in the total de-rating factor used to calculate wire ampacity.

**Total correction** Displays the calculated total correction factor based on the individual de-rating settings. You can manually set the total de-rating value. The value is multiplied with the defined ampacity to calculate the actual de-rated ampacity of the wire.

### Parameters

<b>Run distance</b>	Specifies whether to consider the length of the wire run in calculation of the voltage drop. When Run distance is on, sets the distance.
<b>Units</b>	When Run distance is on, sets the distance units.
<b>Via</b>	When Run distance is on, sets the type of conduit or raceway which affects the voltage drop calculation. The available types are extracted from the electrical standards database file.
<b>Power factor</b>	When Run distance is on, sets the power factor value used to calculate the voltage drop.
<b>Maximum % voltage drop</b>	Specifies whether to apply a maximum percent voltage drop limit on what size wires are appropriate. When Maximum voltage drop is on, sets the acceptable maximum percentage of voltage drop along the wire length.

### Paralleled wires

<b>Include paralleled wire options</b>	Specifies whether to include paralleled wire options in the display. When on, the display includes entries consisting of two or more smaller size conductors per phase to meet the ampacity requirement of the load.
<b>Maximum paralleled wire count</b>	When Include paralleled wire options is on, sets the maximum conductors per phase to use in the calculation and display.
<b>Minimum paralleled wire size</b>	When Include paralleled wire options is on, sets the minimum wire size to use for paralleled conductor calculations.

### Cost per kwh

Sets the cost per kilowatt hour used in the wire loss calculations.

### Wire grid

Displays the available wire conductors, extracted from the electrical standards database, for selection. Wires that do not meet the ampacity requirements are shown in red.

<b>Size</b>	Wire sizes extracted from the wire ampacity table in the electrical standards database.
<b>Count</b>	When Include Paralleled Wire options is on, indicates the number of conductors per phase.
<b>Fill</b>	When Include Paralleled Wire options is on, indicates the fill calculation which takes into account the fill correction. <hr/> <b>NOTE</b> This value is displayed regardless of the state of the Fill correction check box when the Include Paralleled Wire options is on. <hr/>
<b>Ampacity</b>	Calculated ampacity for the conductor. It is the ampacity, extracted from the wire ampacity table, multiplied by the total correction de-rating factor.
<b>%Ampacity</b>	The Maximum load value divided by the Ampacity. It indicates if the wire is close to being fully loaded.
<b>Voltage Drop</b>	The calculated voltage drop from one end of the power run to the other. It can only be calculated if the conductor length is defined.



ID	SIZE	C1	C2	C3
3	14	0.240; 10.2	0.19; 10.2	0.19; 10.2
4	12	0.223; 6.6	0.177; 6.6	0.177; 6.6
5	10	0.207; 3.9	0.164; 3.9	0.164; 3.9
6	8	0.213; 2.56	0.171; 2.56	0.171; 2.56

**Wire Size Lookup**

Load: Voltage: 208, Phase: 3, FLA: 2.08, FLA multiplier: 1.25, FLA (Other): 3.25, Maximum load: 5.85

Wire: Size standard: AWG, Type/method: CU, Insulation: THWN / 75C

Derating factors: Continuous load correction: 0.8, Fill correction: 0.7, Ambient temperature correction: 1.0, Total correction: 0.7

Parameters: Run distance: 20, Units: FT, Via: Steel Conduit, Power factor: 0.85, Maximum % voltage drop: 3

Paralleled wires: Include paralleled wire options:  Maximum paralleled wire count: 4, Minimum paralleled wire size: 1-0

Cost per kwh: 0.08

\*Maximum cost of wire losses for continuous use at rated load

Size	Ampacity	%Ampacity	Voltage Drop	%Voltage Drop	Wire KW Loss	Wire Loss estimate(maximum annual cost)*
14 AWG	10.5	55.71	0.5	0.24	-	-
12 AWG	14	41.79	0.32	0.15	-	-
10 AWG	21	27.86	0.19	0.09	-	-
8 AWG	35	16.71	0.13	0.06	-	-
6 AWG	45.5	12.86	0.08	0.04	-	-
4 AWG	59.5	9.83	0.05	0.02	-	-
3 AWG	70	8.36	0.04	0.02	-	-
2 AWG	80.5	7.27	0.04	0.02	-	-
1 AWG	91	6.43	0.03	0.01	-	-
1-0 AWG	105	5.57	0.02	0.01	-	-
2-0 AWG	122.5	4.78	0.02	0.01	-	-
3-0 AWG	140	4.14	0.02	0.01	-	-

Grounding conductor size: 14 AWG

3-phase calculation:  $1.732 \times \text{Length} \times 0.0003048 \times (\text{FLA} + \text{Other}) \times (\text{Resistance} \times \text{Power Factor} + \text{Reactance} \times (\sqrt{1 - \text{Power Factor}^2}))$

Single phase calculation:  $2.0 \times \text{Length} \times 0.0003048 \times (\text{FLA} + \text{Other}) \times (\text{Resistance} \times \text{Power Factor} + \text{Reactance} \times (\sqrt{1 - \text{Power Factor}^2}))$

**%Voltage Drop**

The Voltage Drop value divided by the applied voltage and multiplied by 100.

**Wire KW Loss**

Calculated from the Voltage Drop and FLA.

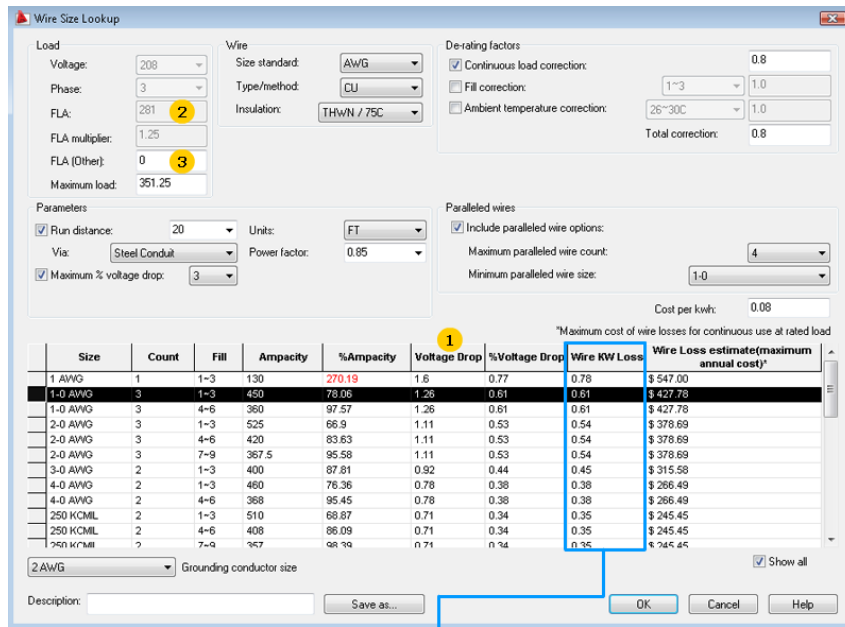

3-phase calculation  
 $1.732 \times \text{Voltage Drop } 1 \times (\text{FLA } 2 + \text{Other } 3) / 1000$

Single phase calculation  
 $\text{Voltage Drop } 1 \times (\text{FLA } 2 + \text{Other } 3) / 1000$

**Wire Loss estimate (maximum annual cost)** Maximum cost of wire losses for continuous use at rated load.

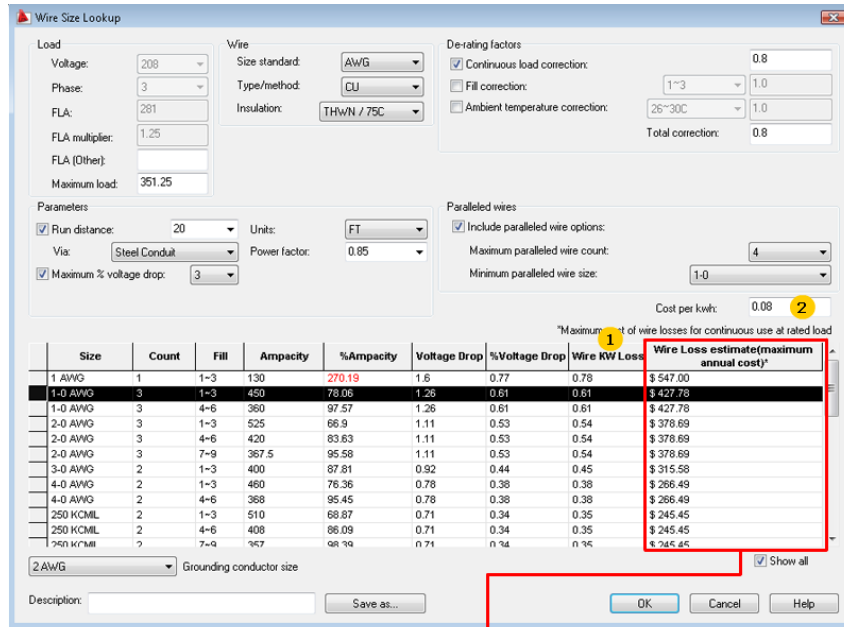

The estimated annual cost of the energy lost  
 Wire KW loss 1 x 24 x 365.25 x Cost per kw/h 2

**Show all**

Specifies whether to display entries where the %Ampacity value is greater than 100%. When Show all is on, values that are greater than 100% are shown in red. Entries >= 300% ampacity are never shown in the list.

**Grounding conductor size**

Displays the minimum size grounding conductor based on the FLA of the motor or power feed. Select a larger conductor size from the list.

The suggested wire conductor size is determined from the appropriate AMPG\* table in the [electrical standards database](#) on page 663 file.

**Save as**

**Save as**

Saves the current settings, wire options, and identifying values from the Select Motor dialog box as an external file.

**Description**

Assigns a description for the parameters and wire options. Uses this description when you select Save as to save the current settings and wire options as an external file.

## Recalculate wire size

### Recalculating wire size

Displays Wire Size Lookup dialog box with previous calculated data for selected motor or power feed load representation.

- 1 Click Schematic tab ► Insert Components panel ► Circuit Builder



drop-down ► Recalculate Wire Size.

- 2 Select the motor or power feed load symbol.  
The Wire Size Lookup dialog box displays.

---

**NOTE** If the necessary load xdata does not exist on the selected motor or load symbol, the Select Motor or Select Load dialog box displays first.

---



- 3 Adjust the parameters as necessary.
- 4 Select a wire conductor size from the list.
- 5 Select a grounding conductor size. A suggested minimum size is preselected. This is controlled by the appropriate AMPG\* table in the electrical standards database file.
- 6 (Optional) Enter a description for the parameters, click Save As, and enter a name for the output file  
The input parameters, wire sizes, and selected wire size are saved to an external file. This can be either a new file or appended to an existing file in xls, csv, or text format.
- 7 Click OK.



The new wire layer name is determined, preserving any color substring in the existing layer name, and the connected wires are updated.

### Recalculate wire size

Displays Wire Size Lookup dialog box with previous calculated data for selected motor or power feed load representation.

 **Ribbon:** Schematic tab ► Insert Components panel ► Circuit Builder

drop-down ► Recalculate Wire Size.  

   
**Toolbar:** Main Electrical

 **Menu:** Wires ► Recalculate Wire Size

 **Command entry:** AEEDITWS

When Circuit Builder inserts a circuit, the parameters used to size the wires are saved on the motor or load symbol as xdata. To recalculate the wire size, select the motor or load symbol when prompted. The [Wire Size Lookup](#) on page 712 dialog box displays the existing values as defaults. Make design decisions, adjusting parameters as needed, and select an appropriate wire size. The wire layer name is updated to reflect the selected size.

---

**NOTE** If the xdata does not exist on the selected motor or load symbol, the Select Motor or Select Load dialog box displays first.

---

## Reference an existing circuit

When a new circuit is inserted, you can reference an existing circuit picked from a list of circuits pulled from the active project. The components, values, descriptions, and tag assignments from the selected circuit, become defaults for the new circuit.

This feature can be especially useful when inserting 3-phase circuits based on existing one-line circuits. The components for each circuit element for the one-line circuit become the default for the new 3-phase circuit. The tag assignments and values are pulled across from the referenced one-line circuit. Alternately, new component tags are generated if the option “Retag new component” is selected.

Referencing an existing circuit uses xdata (AutoCAD Extended Entity Data) added on the motor or load symbol by Circuit Builder when the circuit is inserted.

**VIA\_WD\_CB\_CIRCCODES** - semi-colon delimited list of template marker codes, inserted component handles, and spreadsheet UI\_VAL selection

values. The template marker code maps the values from the components in the existing circuit to the components in the new circuit.

**VIA\_WD\_CB\_CIRCPARAMS** - comma-delimited list that includes data returned from any Select Motor or Select Load dialog box.

**VIA\_WD\_CB\_CIRCPARAMS2** - list of motor or load wire size assignments.

**VIA\_WD\_CB\_CIRCSELECT** - comma-delimited list that includes the template name, spreadsheet file name, and sheet name.

---

**NOTE** If there are no existing circuits in the active project that carry the VIA\_WD\_CB\_CIRCCODE xdata, the "Reference Existing Circuit" option is disabled.

---

Referencing an existing circuit depends on:

- Marker block CODE values
- UI\_VAL values from the circuit builder spreadsheet

### Marker Block CODE values

Referencing an existing circuit depends on finding matching marker block CODE values used in both the referenced circuit and the circuit being inserted or configured. For example, a referenced one-line circuit used marker block code Q001 to trigger insertion of the main disconnecting means. The new three-line schematic circuit being inserted needs to have a marker block code Q001 marking where the three-pole disconnecting means is to be inserted. The result is that component values from the referenced circuit are applied to components in the new circuit when the [marker block](#) on page 659 codes match.

### Spreadsheet UI\_VAL values

The default circuit element options are controlled by both the CODE value and the UI\_VAL from the [circuit codes sheet](#) on page 655 of the circuit builder spreadsheet. There may be multiple options for a particular CODE value. For example, the main disconnecting means may have the following options, each with a UI\_VAL assigned.

Main Disconnecting Means Option	UI_VAL
Disconnect switch - non-fused	2
Disconnect switch and fuses	4

Main Disconnecting Means Option	UI_VAL
Disconnect switch and fuses (time-delay)	6
Fuses	8
Fuses (time-delay)	10
Circuit Breaker	12
Circuit Breaker-thermal/inverse-time	14
Circuit Breaker-magnetic/instantaneous	16
None	0

For example, the one-line circuit used the Disconnect switch and fuses (time-delay) option with a UI\_VAL of “6”. When the 3-phase circuit references this one-line circuit, the disconnecting means option with a UI\_VAL of “6” becomes the default. If a matching UI\_VAL is not found for a particular marker block CODE value, the default as defined by the “X” in the UI\_DEF column is used.

## Reference an existing circuit

- 1 Click Schematic tab ► Insert Components panel ► Circuit Builder



drop-down ► Circuit Builder.

- 2 Select the circuit from the Circuits list or select History to display the list of previously configured circuits.
- 3 (Optional) Enter a Circuit Scale. This value sets an insertion scale value for the circuit template.
- 4 (Optional) Enter a Component Scale. This value sets an insertion scale value for the individual components inserted while building the circuit.
- 5 (Optional) Enter a Horizontal Rung Spacing.
- 6 (Optional) Enter a Vertical Rung Spacing.
- 7 Select Reference Existing Circuit.

- 8 Select the List button. The Existing Circuits dialog box displays with a row for each circuit carrying the necessary xdata.
- 9 Select a circuit row.
- 10 Select OK.
- 11 Select to Retag new components or use the same tags as the referenced circuit.
- 12 Select Insert or Configure. Default circuit elements and values for the circuit are based on the referenced circuit.
- 13 Continue as described in [Insert a 3-phase circuit](#) on page 688 or [Configure a 3-phase circuit](#) on page 690.
- 14 Select Done.

## Use circuitry

You can save groupings of components, wires, ladders, and other entities as circuits. Like blocks, saved circuits are inserted as a single object. Saved circuits save time when your projects require common arrangements of components, such as motor starters or control circuits.

When you use any of the AutoCAD Electrical Insert Circuit commands to insert a circuit, the circuit explodes. Wire numbers and component tags are updated according to the tag settings of the current drawing. However, fixed tags are not updated.

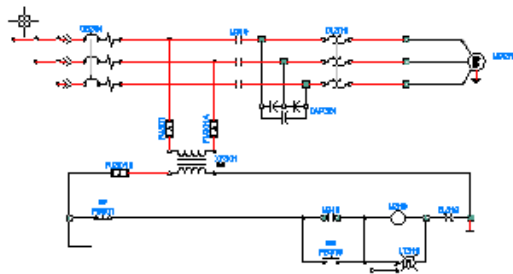

## Copy circuitry

Copies windowed circuitry in the active drawing, and includes automatic update of the component tag.



The components are retagged automatically based on their new line reference locations. If the circuit you copied contains fixed wire numbers or component tags, you have the options to keep them or update them based on the new line reference locations.

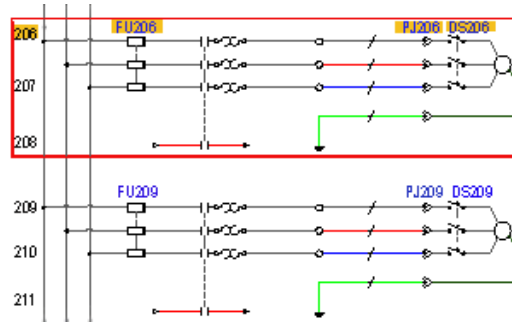

- 1 Click Schematic tab ► Edit Components panel ► Circuit



drop-down ► Copy Circuit.

- 2 Select the components and wires to copy. Carefully window (from left to right) around the circuit, making sure to capture the connection wires and dots that tie in to the vertical bus.
- 3 Press Enter.
- 4 (Optional) Press M to make multiple copies of the selected circuit.
- 5 Select the base point and then the second point for the copy.

---

**NOTE** If the circuit you copied contains any fixed wire numbers or component tags, specify to keep them, blank them out, retag all the found tags, or keep all orphan contacts.

---

## Move circuitry

Moves windowed circuitry on an active drawing to a new insertion point with automatic component tag update.

Moves the selected circuit to a specified location. Retags components automatically based on their new line reference locations, and updates cross-references.

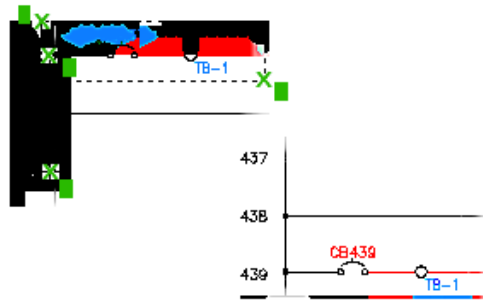

- 1 Click Schematic tab ► Edit Components panel ► Circuit



drop-down ► Move Circuit.

- 2 Select the circuit to move. Carefully window (from left to right) around the circuit, making sure to capture the connection wires and dots that tie in to the vertical bus.
- 3 Press Enter.
- 4 Select the base point, and then the second point for the move.

## Save circuit portions for later use

Use this tool to save circuit portions for later use.

---

**NOTE** You can also use the AutoCAD WBLOCK command to save circuits to disk and then use the Insert Wblocked Circuit tool to insert the circuit.

---

- 1 Zoom around the circuit to save so that it fills your screen.
- 2 Click Schematic tab ► Edit Components panel ► Circuit



drop-down ► Save Circuit To Icon Menu.

- 3 On the Save Circuit to Icon Menu dialog box, right-click in the Symbol Preview window and select Add icon ► New circuit.

---

**NOTE** You can also click the arrow on the Add tab and select New circuit.

---

- 4 On the Create New Circuit dialog box, specify:
  - Name of the icon.
  - Image file to use. Make sure to select Create PNG from current screen image.
  - Circuit drawing file name.

---

**NOTE** If you did not zoom in on the circuit in the previous step 1, you can click Zoom on the Create New Circuit dialog box to zoom around the circuit to save.

---

- 5 Click OK.
- 6 Select the insertion base point of the circuit.
- 7 Window around the circuit (from left to right), capturing all the appropriate components and wiring and press Enter.  
AutoCAD Electrical processes the circuit and saves it to your AutoCAD Electrical user subdirectory.

---

**NOTE** You can overwrite the user subdirectory using the wd\_usercktdir setting in the environment (.env) file. For example, if wd\_usercktdir is enabled and set to "N:\Electrical\Circuits", the new circuit and image file are saved to N:\Electrical\Circuits.

---

AutoCAD Electrical creates and adds a new circuit icon (.png) of your circuit to the bottom of the symbol preview window.

### Add existing circuits to the icon menu

Use the Save Circuit to Icon Menu tool to add existing circuits to the icon menu. You can then select the circuit from the Insert Component dialog box for insertion into a drawing.

- 1 Click Schematic tab ► Edit Components panel ► Circuit



drop-down ► Save Circuit To Icon Menu.

- 2 On the Save Circuit to Icon Menu dialog box, right-click in the Symbol Preview window and select Add icon ► Add circuit.

---

**NOTE** You can also click the arrow on the Add tab and select Add circuit.

---

- 3 On the Add Existing Circuit dialog box, specify:
  - Name of the icon.
  - Image file to use. Make sure to select Create PNG from current screen image.
  - Existing circuit name.
- 4 Click OK.  
The existing circuit is added to the bottom of the symbol preview window.

### Insert a saved circuit

Inserts a previously saved circuit you select from the icon menu.

After you specify an insertion point, the circuit inserts and the component tags update. The circuit behaves as if you inserted components and wires one at a time.

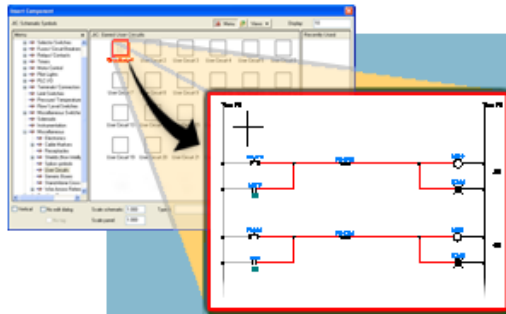

You can insert circuits you saved using the Save Circuit to Icon Menu tool or circuits that you saved using WBLOCK command in AutoCAD. You can then edit the component tags, run the wire numbering tool, or add or delete components and wiring.

- 1 Click Schematic tab ► Insert Components panel ► Circuit



drop-down ► Insert Saved Circuit.

- 2 On the Insert Component dialog box, select the circuit you want to insert into the drawing from the Symbol Preview window.
- 3 Click OK.

- 4 On the Circuit Scale dialog box, click OK to use the defaults or specify a scale and then click OK.
- 5 Specify the insertion point on the drawing.

### Insert a WBlocked circuit

Inserts WBlocked circuitry (external drawing file) with automatic update of the component tag.

Inserts a previously saved group of components, wires, ladders, and other entities as circuits. Saved circuits insert as a single object and are then exploded. Component tags update according to the tag settings in the drawing. Fixed tags do not update. Saved circuits provide common arrangements of components, such as motor starters or control circuits in projects.

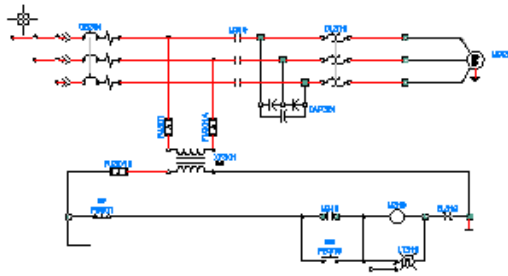

- 1 Click Schematic tab ► Insert Components panel ► Circuit



drop-down ► Insert WBlocked Circuit.

- 2 On the Insert WBlocked Circuit dialog box, select the circuit you want to insert into the drawing and click Open.
- 3 On the Circuit Scale dialog box, click OK to use the defaults or specify a scale and then click OK.
- 4 Specify the insertion point on the drawing.

### Insert component

This icon menu can be modified, expanded, or replaced with a custom menu. You can change the default icon menu using the Library and Icon Menu Paths section of the [Project properties: project settings tab](#) on page 204. Use the Icon

Menu Wizard to modify the menu. The default icon menu can also be redefined in *wd.env*. Add entry "WD\_MENU" for schematic icon menu and "WD\_PMENU" for panel layout icon menu.

### Insert Component

 **Ribbon:** Schematic tab ► Insert Components panel ► Insert Components

  
drop-down ► Icon Menu.



 **Toolbar:** Main Electrical

 **Menu:** Components ► Insert Component

 **Command entry:** AECOMPONENT

### Multiple Insert (Icon Menu)

 **Ribbon:** Schematic tab ► Insert Components panel ► Multiple Insert

  
drop-down ► Multiple Insert (Icon Menu).



 **Toolbar:** Main Electrical

 **Menu:** Components ► Multiple Insert ► Multiple Insert (Icon Menu)

 **Command entry:** AEMULTI

---

**NOTE** This dialog box is also accessed when inserting Pneumatic, Hydraulic, or P&ID components; in-line wire labels; stand-alone cross-reference symbols; cable markers; and saved circuits.

---

Select an icon picture or the component type from the Menu tree structure. The main menu in the tree structure is displayed as the menu heading just above the menu tree structure.

#### Tabs

- Menu: Changes the visibility of the Menu tree view.
- Up one level: Displays the menu that is one level before the current menu in the Menu tree view. This option is unavailable if the main menu is selected in the Menu tree view.

- Views: Changes the view display for the Symbol Preview window and Recently Used window. The current view option is indicated with a check mark. Options include: Icon with text, Icon only or List view.

**Menu** The tree structure is created by reading the icon menu file (.dat). The tree structure is based on the arrangement order of submenus defined in the .dat file.

**Symbol Preview window** Displays the symbol and submenu icons corresponding to the menu or the submenu selected in the Menu tree structure. Clicking on the icon performs one of the following functions based on the icon properties as defined by the .dat file:

- Inserts the symbol or circuit onto the drawing
- Executes a command
- Displays a submenu

---

**NOTE** When you move the cursor over an icon, the icon name and block/circuit/command name display as tooltip information.

---

**Recently Used** Displays the last components inserted during the current editing session; the most recently used icon displays in the top. This list follows the view options setting in the symbol preview window (icon only, icon with text or list view). The total number of icons displayed depends on the value specified in the Display edit box.

**Display** Specifies the number of icons to display in the Recently Used list box. Enter integer numbers only; the default value is 10.

**Vertical/Horizontal** Inserts the icon using a vertical or horizontal orientation. This value is opposite the default ladder rung orientation for the drawing.

**No edit dialog** Turns off the Insert/Edit Component dialog box when inserting symbols onto the drawing. To add component detail later, click the Edit Component tool, and select the component to edit.

**No tag** Inserts the component, untagged (that is, without assigning a unique Component Tag). The untagged value that displays is the TAG1/TAG2 default value for the component. To add component

detail later, click the Edit Component tool, and select the component to edit.

<b>Always display previously used menu</b>	Indicates to display the previously used menu each time you open the Insert Component dialog box. For example, if you insert a push button from the Push Buttons menu, the next time you open the Insert Component dialog box the Push Button menu displays by default.
<b>Scale schematic</b>	Specifies the component block insertion scale. This defaults to the value set in the Drawing Properties ► Drawing Format dialog box. Once set, this value is remembered until reset or until the drawing editing session ends.
<b>Scale panel</b>	Specifies the footprint insertion scale. This defaults to the value set in the Drawing Properties ► Drawing Format dialog box. Once set, this value is remembered until reset or until the drawing editing session ends.
<b>Type it</b>	Manually type in the component block to insert.
<b>Browse</b>	Browses to and selects the component to insert.

## Right-click menus

### Options for the Menu tree structure view

Right-click on the main menu or submenu in the Menu tree structure view to display the following options:

- Expand/Collapse: Toggles the visibility of the menus.
- Properties: Opens a Properties dialog box to view the existing menu or submenu properties like the menu name, image, or submenu title. Use the Icon Menu Wizard to change any menu properties.

### Options for the Symbol Preview window

Right-click an icon or in empty space in the Symbol Preview window to display the following options:

- View: Changes the view display for the Symbol Preview window and Recently Used window. The current view option is indicated with a check mark. Options include: Icon with text, Icon only or List view.



- **Properties:** (available for icons only) Opens a Properties dialog box to view the existing symbol icon properties like the icon name, image, block names and so on. Use the Icon Menu Wizard to change any icon properties.

### **Pneumatic, Hydraulic, and P&ID icon menus**

The Menu tree structure displays the symbols for the selected component type (pneumatic, hydraulic, or P&ID). The Insert Pneumatic Component, Insert Hydraulic Component, and Insert P&ID Component tools are accessed from the Schematic tab ► Insert Components panel on the ribbon or the Extra Library toolbar.



Insert Pneumatic Component



Insert Hydraulic Component



Insert P&ID Component

### **Save circuit to icon menu**

Saves windowed circuitry to the Saved User Circuits page of the icon menu.

🔗 **Ribbon:** Schematic tab ► Edit Components panel ► Circuit



drop-down ► Save Circuit To Icon Menu.



🔗 **Toolbar:** Circuits

🔗 **Menu:** Components ► Save Circuit To Icon Menu

🔗 **Command entry:** AESAVECIRCUIT

Saves windowed portions of circuitry for later reuse. You can save up to 24 circuits at a time in this menu.

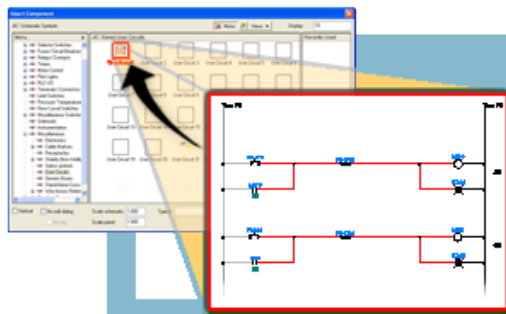

---

**TIP** To get a good icon picture for the circuit button, zoom in close to the circuit you plan to save so that it fills the screen.

---

### Menu

The tree structure is created by reading the icon menu file (\*.dat). The tree structure is based on the arrangement order of submenus defined in the .dat file.

### Tabs

- Menu: Changes the visibility of the Menu tree view.
- Up one level: Displays the menu that is one level before the current menu in the Menu tree view.
- Views: Changes the view display for the Symbol Preview window. The current view option is indicated with a check mark. Options include: Icon with text, Icon only, or List view.
- Add: Modifies the icon menu by adding icons for circuits or a new submenu.

### Symbol Preview window

Displays the symbol images corresponding to the menu or the submenu selected in the Menu section. You can drag icons within the Symbol Preview window for re-arrangement (multiple selection is allowed). For example, place commonly used icons at the top and rarely used icons at the bottom of the window.

## Symbol Preview right-click menu

Right-click in empty space in the Symbol Preview window to display the following options:

- **View:** Changes the view display for the Symbol Preview window. The current view option is marked with a check mark. Options include: Icon with text, Icon only, or List view.
- **Add Icon:** Adds new circuit icons or an existing circuit into the Symbol Preview window.
- **New Submenu:** Creates a submenu in the Symbol Preview window and the tree structure.
- **Cut:** Removes the selected icon from the Symbol Preview window. You can then paste the icon into the desired submenu.
- **Copy:** Makes a copy of the highlighted icon and stores it in the Paste clipboard. You can then paste the icon into the desired submenu.
- **Paste:** Adds the copied or cut icon to the highlighted submenu.
- **Delete:** Deletes the icon.
- **Properties:** Opens a Properties dialog box to modify the existing symbol icon properties like the icon name, image, or block names. The existing data in the \*.dat file is overwritten with your changes.

---

**NOTE** You can change the user circuit menu number (default is 19) by editing this command in the CUI editor.

---

## Circuit scale

Use this tool to specify the scale and options for circuit insertion.

### Insert Saved Circuit

 **Ribbon:** Schematic tab ► Insert Components panel ► Circuit

drop-down ► Insert Saved Circuit.

 **Toolbar:** Circuits

 **Menu:** Components ► Insert Saved Circuit

 **Command entry:** AESAVEDCIRCUIT

### Insert WBlocked Circuit

 **Ribbon:** Schematic tab ► Insert Components panel ► Circuit



drop-down ► Insert WBlocked Circuit.



 **Toolbar:** Circuits

 **Menu:** Components ► Insert WBlocked Circuit

 **Command entry:** AEWBCIRCUIT

<b>Custom scale</b>	Specifies the insertion scale.
<b>Move all lines to wire layers</b>	Moves all non-layer "0" line entities to a valid wire layer.
<b>Keep all fixed wire numbers</b>	Indicates not to erase wire numbers if they are fixed.
<b>Keep all source arrows</b>	Indicates not to erase the source arrows of the circuit.
<b>Update circuit's text layers as required</b>	Updates the layers of the circuit per AutoCAD Electrical assignment.
<b>Don't blank out orphan contacts</b>	Leaves the tag ID alone if parent is not found.

## Insert schematic components

### Insert schematic components

Inserts a component you select from the icon menu.

Pick an insertion point on the drawing. The orientation of the symbol tries to match the underlying wire. The wire breaks automatically if the symbol lands on it or very near it.

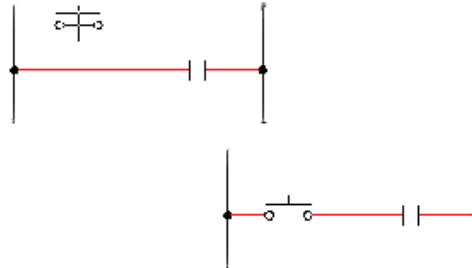

- 1 Click Schematic tab ► Insert Components panel ► Insert Components

drop-down ► Icon Menu. 

- 2 In the Insert Component dialog box, select the starting orientation for the component: horizontal or vertical.

- 3 (Optional) If you want to turn off the Insert/Edit Component dialog box when inserting symbols onto the drawing select No Edit dialog box.
- 4 (Optional) If you want to insert the component, untagged (for example, without assigning a unique Component Tag) select No Tag. The untagged value that displays is the TAG1/TAG2 default value of the component.
- 5 Select the component to insert (such as Push Buttons ► Push Button N.O.) Select an icon picture or the component type from the left-hand list.  
The right-hand column of the menu displays the last ten components inserted during the current editing session.
- 6 Specify the insertion point in the drawing.  
The orientation of the symbol tries to match the underlying wire. The wire breaks automatically if the symbol lands on it.
- 7 On the Insert/Edit Component dialog box, annotate the component.
- 8 Click OK.

## Insert component

This icon menu can be modified, expanded, or replaced with a custom menu. You can change the default icon menu using the Library and Icon Menu Paths section of the [Project properties: project settings tab](#) on page 204. Use the Icon Menu Wizard to modify the menu. The default icon menu can also be redefined in *wd.env*. Add entry "WD\_MENU" for schematic icon menu and "WD\_PMENU" for panel layout icon menu.

### Insert Component

 **Ribbon:** Schematic tab ► Insert Components panel ► Insert Components

drop-down ► Icon Menu.



 **Toolbar:** Main Electrical

 **Menu:** Components ► Insert Component

 **Command entry:** AECOMPONENT

## Multiple Insert (Icon Menu)

 **Ribbon:** Schematic tab ► Insert Components panel ► Multiple Insert

drop-down ► Multiple Insert (Icon Menu).



 **Toolbar:** Main Electrical

 **Menu:** Components ► Multiple Insert ► Multiple Insert (Icon Menu)

 **Command entry:** AEMULTI

---

**NOTE** This dialog box is also accessed when inserting Pneumatic, Hydraulic, or P&ID components; in-line wire labels; stand-alone cross-reference symbols; cable markers; and saved circuits.

---

Select an icon picture or the component type from the Menu tree structure. The main menu in the tree structure is displayed as the menu heading just above the menu tree structure.

### Tabs

- Menu: Changes the visibility of the Menu tree view.
- Up one level: Displays the menu that is one level before the current menu in the Menu tree view. This option is unavailable if the main menu is selected in the Menu tree view.
- Views: Changes the view display for the Symbol Preview window and Recently Used window. The current view option is indicated with a check mark. Options include: Icon with text, Icon only or List view.

### Menu

The tree structure is created by reading the icon menu file (.dat). The tree structure is based on the arrangement order of submenus defined in the .dat file.

### Symbol Preview window

Displays the symbol and submenu icons corresponding to the menu or the submenu selected in the Menu tree structure. Clicking on the icon performs one of the following functions based on the icon properties as defined by the .dat file:

- Inserts the symbol or circuit onto the drawing
- Executes a command
- Displays a submenu

---

**NOTE** When you move the cursor over an icon, the icon name and block/circuit/command name display as tooltip information.

---

<b>Recently Used</b>	Displays the last components inserted during the current editing session; the most recently used icon displays in the top. This list follows the view options setting in the symbol preview window (icon only, icon with text or list view). The total number of icons displayed depends on the value specified in the Display edit box.
<b>Display</b>	Specifies the number of icons to display in the Recently Used list box. Enter integer numbers only; the default value is 10.
<b>Vertical/Horizontal</b>	Inserts the icon using a vertical or horizontal orientation. This value is opposite the default ladder rung orientation for the drawing.
<b>No edit dialog</b>	Turns off the Insert/Edit Component dialog box when inserting symbols onto the drawing. To add component detail later, click the Edit Component tool, and select the component to edit.
<b>No tag</b>	Inserts the component, untagged (that is, without assigning a unique Component Tag). The untagged value that displays is the TAG1/TAG2 default value for the component. To add component detail later, click the Edit Component tool, and select the component to edit.
<b>Always display previously used menu</b>	Indicates to display the previously used menu each time you open the Insert Component dialog box. For example, if you insert a push button from the Push Buttons menu, the next time you open the Insert Component dialog box the Push Button menu displays by default.
<b>Scale schematic</b>	Specifies the component block insertion scale. This defaults to the value set in the Drawing Properties ► Drawing Format dialog box. Once set, this value is remembered until reset or until the drawing editing session ends.
<b>Scale panel</b>	Specifies the footprint insertion scale. This defaults to the value set in the Drawing Properties ► Drawing Format dialog box. Once set, this value is remembered until reset or until the drawing editing session ends.
<b>Type it</b>	Manually type in the component block to insert.



**Browse**

Browses to and selects the component to insert.

### **Right-click menus**

#### **Options for the Menu tree structure view**

Right-click on the main menu or submenu in the Menu tree structure view to display the following options:

- **Expand/Collapse:** Toggles the visibility of the menus.
- **Properties:** Opens a Properties dialog box to view the existing menu or submenu properties like the menu name, image, or submenu title. Use the Icon Menu Wizard to change any menu properties.

#### **Options for the Symbol Preview window**

Right-click an icon or in empty space in the Symbol Preview window to display the following options:

- **View:** Changes the view display for the Symbol Preview window and Recently Used window. The current view option is indicated with a check mark. Options include: Icon with text, Icon only or List view.
- **Properties:** (available for icons only) Opens a Properties dialog box to view the existing symbol icon properties like the icon name, image, block names and so on. Use the Icon Menu Wizard to change any icon properties.

### **Pneumatic, Hydraulic, and P&ID icon menus**

The Menu tree structure displays the symbols for the selected component type (pneumatic, hydraulic, or P&ID). The Insert Pneumatic Component, Insert Hydraulic Component, and Insert P&ID Component tools are accessed from the Schematic tab ► Insert Components panel on the ribbon or the Extra Library toolbar.



Insert Pneumatic Component



Insert Hydraulic Component



Insert P&ID Component

## Insert/edit component

Edits a component, PLC module, terminal block, wire number, or signal arrow.

### Insert Component

 **Ribbon:** Schematic tab ► Insert Components panel ► Insert



Components drop-down ► Icon Menu.



 **Toolbar:** Main Electrical

 **Menu:** Components ► Insert Component

 **Command entry:** AECOMPONENT

Select the component type to insert and specify the insertion point on the drawing.

### Edit Component

 **Ribbon:** Schematic tab ► Edit Components panel ► Edit Components



drop-down ► Edit.



 **Toolbar:** Main Electrical

 **Menu:** Components ► Edit Component

 **Command entry:** AEEDITCOMPONENT

Select the component to edit.

You can go back to a component at any time and edit values such as tag, catalog assignment, location, installation, descriptions, ratings, and miscellaneous values. Related components update to match the new values.

While inserting a component for the first time you establish its tag definition inside of the project. If the component could potentially reference other

components found on different drawing files in the project, the relationship must be established before editing. The steps to link the new component with related components are:

- 1 Insert a new component and change the component tag as needed.
- 2 Click OK and insert the component on the drawing.
- 3 Right-click the component and select Edit Component.
- 4 Change the description, catalog data, and so on, as needed.
- 5 Click OK.
- 6 In the Update Related Components dialog box, click Yes-Update to update the related components with your changes. Click Skip to update only the component you edited.

---

**NOTE** Some options are not available depending on whether you are inserting a single component or multiple components.

---

### Component Tag

Any existing tags appear in the edit box. To define the component tag, edit the existing tag or type a specific tag in the edit box. Select Fixed if you do not want this tag to update on a retag.

If you enter an existing component tag during the insert/edit process, a warning dialog box displays. (Turn off the warning in the Project Properties ► Project Settings dialog box. It temporarily disables the warning dialog box for the current session of AutoCAD Electrical). It alerts you of the duplication and suggests alternative tag names based on the user-defined format. You can select whether to use the duplicated tag or use a new tag that is suggested (or you can type in a new tag).

---

**NOTE** An error log file is created for every project regardless of whether you chose to display the real-time warning dialog box or not. The real-time warning is saved in the log file named "<project\_name>\_error.log" and is saved in the User subdirectory.

---

#### Use PLC Address

Searches for a wire connection to a nearby PLC I/O address and, if found, uses the PLC address number in the tag name of the component.

<b>Tags Used: Schematic</b>	Lists used component tag names. Select a tag from the list to copy, or to increment for this new component. Initially, the list includes schematic parent components in the same family as the current component. Select to include children, all families, panel, and one-line components in the list.
<b>Tags Used: Panel</b>	Lists used panel component tag names. Select a tag from the list to copy, to this new component. An "x" in front of the tag indicates there is a schematic component already inserted. An "o" in front of the tag indicates a schematic component exists but there is mismatch on Catalog and Manufacturer values between the two.
<b>External List</b>	Assigns a tag from an external list file. You can reference an ASCII text file in comma or space delimited format to help annotate the component's description, tag, catalog, and other information of the component.
<b>Options</b>	Substitutes a fixed text string for the %F part of the tag format. Enter a tag format override in the edit box. Retag Component uses this override format value to calculate a new tag for the selected component.

### **Catalog Data**

You can do a drawing-wide or project-wide listing of similar components with their catalog assignments. During your editing session, the last MFG / CAT / ASSYCODE assignment for each component type you insert into your wiring diagram is remembered. When you insert another component of that type, the previous catalog assignment of the component is set as the default (assuming a previous one was made during the current editing session).

<b>Manufacturer</b>	Lists the manufacturer number for the component. Enter a value or select one from the Catalog lookup.
<b>Catalog</b>	Lists the catalog number for the component. Enter a value or select one from the Catalog lookup.
<b>Assembly</b>	Lists the assembly code for the component. The Assembly code is used to link multiple part numbers together.
<b>Item</b>	Specifies a unique identifier assigned to each component. The tag value can be manually typed in the edit box.

<b>Count</b>	Specifies the quantity number for the part number (blank=1). This value gets inserted into the "SUBQTY" column of the BOM report.
<b>Lookup</b>	Opens the catalog database of the component from which you can manually enter or select the Manufacturer or Catalog values. Search the database for a specific catalog item to assign to the selected component.
<b>Previous</b>	Scans the previous project to find an instance of the selected component and returns the component values. You can then make your catalog assignment by picking from the dialog box list.
<b>Drawing</b>	Lists the part numbers used for similar components in the current drawing.
<b>Project</b>	<p>Lists the part numbers used for similar components in the project. You can search in the active project, another project, or an external file.</p> <ul style="list-style-type: none"> <li>■ <b>Active project:</b> All the drawings in the current project are scanned and the results are listed in a dialog box. Select from the list to assign your new component with a catalog number that is consistent with other similar components in the project.</li> <li>■ <b>Other project:</b> Scans each listed drawing in a previous project for the target component type and returns the catalog information in a subdialog box. Make your catalog assignment by picking from the dialog box list.</li> <li>■ <b>External file:</b> You can pull catalog assignments from a generic ASCII file created by a word processor or output from a spreadsheet or database program. A dialog box displays the contents of the selected text file. Find and highlight the appropriate entry. AutoCAD Electrical reads the line of text from the file and breaks it into its component parts. They are displayed in the left-hand dialog box list. For each relevant item, highlight it, and then pick the appropriate category button in the center column. The highlighted item is transferred to the corresponding category (and then to the Insert/Edit dialog box once OK is clicked).</li> </ul>

**Multiple Catalog** Inserts or edits extra catalog part numbers on to the selected component. You can add up to 99 part numbers to any component. These multiple BOM part numbers appear as sub-assembly part numbers to the main catalog part number in the various BOM and component reports.

**Catalog Check** Displays what the selected item looks like in a Bill of Material template.

### **Ratings**

Specifies values for each ratings attribute. You can enter up to 12 ratings attributes on a component. Select Defaults to display a list of default values.

---

**NOTE** If Ratings is unavailable, the component you are editing does not carry rating attributes.

---

### **Description**

Up to three lines of description attribute text can be entered.

**Drawing** Displays a list of descriptions found in the current drawing so you can pick similar descriptions to edit.

**Project** Displays a list of descriptions found in the project so you can pick similar descriptions to edit.

**Defaults** Opens an ASCII text file from which you can select standard descriptions.

**Pick** Picks a description from a component on the current drawing.

If a symbol does not have the DESC1-3 attributes, the description edit boxes are unavailable. To put descriptions on fuse symbols (or other symbols without these attributes), open the fuse library symbols in AutoCAD Electrical and add the DESC1, DESC2, and DESC3 attribute definitions. Fuse symbol file names are HFU\*.dwg and VFU\*.dwg.

### **Cross-Reference**

**Component override** Overrides the WD\_M block settings of the drawing with component-specific cross-reference settings.

Click Setup to edit the component cross-reference settings manually.

#### Reference NO/ Reference NC

A pin list database table is consulted when a part number is added or an existing part number is changed on a parent symbol. If a match on the Manufacturer, Catalog, and Assembly values of the part number in the database table is found, the associated contact count and pin number information is retrieved and placed on the parent component. Click NO/NC Setup to view or manually edit pin list data values.

### Installation Code

Changes the installation codes. You can search the current drawing or entire project for installation codes. A quick read of all the current or selected drawing files is done and a list of installation codes used so far is returned. Select from the list to update the component with the installation code automatically.

Assign short installation codes to components like "PNL" and "FIELD" so you can create installation-specific BOM and component lists later.

### Location Code

Changes the location codes. You can search the current drawing or entire project for location codes. A quick read of all the current or selected drawing file is done and a list of location codes used so far is returned. Select from the list to update the component with the location code automatically.

Assign short location codes to components like "PNL" and "FIELD" so you can extract cable from/to reports and location-specific BOM reports later. (For example, BOM for all field cables, BOM for all PNL cables.)

### Show/Edit Miscellaneous

View or edit any attributes that are not predefined AutoCAD Electrical attributes.

### Pins

Assigns pin numbers to the pins that are physically located on the component.

**For Connectors:** Once a connector is inserted onto the block definition of the drawing file, you can edit the connector pins found inside of the connector. Click List to display the Connector Pin Numbers in Use dialog box where you can edit the pin numbers and descriptions.

### Switch Positions

Labels the positions of a selector switch.

### OK-Repeat

(not available when editing components) Inserts the new component onto the drawing and then inserts another 'just like' component.

### Insert/edit component: IEC

Assign values on the component such as tag, catalog, location, installation, descriptions, ratings, and miscellaneous values. Related components update to match the new values.

The Insert/Edit Component dialog box is for working in IEC mode. If you are working in JIC mode, the dialog box displays differently.

While inserting a component for the first time you establish its tag definition inside of the project. If the component could potentially reference other components found on different drawing files in the project, the relationship must be established before editing. The steps to link the new component with related components are:

- 1 Insert a new component and change the component tag as needed.
- 2 Click OK and insert the component on the drawing.
- 3 Right-click the component and select Edit Component.
- 4 Change the description, catalog data, and so on, as needed.
- 5 Click OK.
- 6 In the Update Related Components dialog box, click Yes-Update to update the related components with your changes. Click Skip to update only the component you edited.

### Insert Component

 **Ribbon:** Schematic tab ► Insert Components panel ► Insert

Components drop-down ► Icon Menu.

 **Toolbar:** Main Electrical





 **Menu:** Components ► Insert Component

 **Command entry:** AECOMPONENT

Select the component type to insert and specify the insertion point on the drawing.

### Edit Component

 **Ribbon:** Schematic tab ► Edit Components panel ► Edit Components

drop-down ► Edit.



 **Toolbar:** Main Electrical

 **Menu:** Components ► Edit Component

 **Command entry:** AEEDITCOMPONENT

Select the component to edit.

You can go back to any component at any time and make changes.

---

**NOTE** Some options are not available depending on whether you are inserting a single component or multiple components. To insert multiple components, select Components ► Multiple Insert ► Multiple Insert (Icon Menu).

---

### Installation

Changes the installation codes. You can search the current drawing or entire project for installation codes. A quick read of all the current or selected drawing files is done and a list of installation codes used so far is returned. Select from the list to update the component automatically with the installation code.

Assign short installation codes to components like "PNL" and "FIELD" so you can create installation-specific BOM and component lists later.

### Location

Changes the location codes. You can search the current drawing or entire project for location codes. A quick read of all the current or selected drawing files is done and a list of location codes used so far is returned. Select from the list to update the component automatically with the location code.

Assign short location codes to components like "PNL" and "FIELD" so you can extract cable from/to reports and location-specific BOM reports later. (For example, BOM for all field cables, BOM for all PNL cables.)

### Component Tag

Any existing tags appear in the edit box. To define the component tag, edit the tag or type a specific tag in the edit box. Select Fixed if you do not want this tag to update on a retag.

If you enter an existing component tag during the insert/edit process, a warning dialog box displays. This alerts you of the duplication and suggests alternative tag names based on the user-defined format. You can select whether to use the duplicated tag or use a new tag that is suggested (or you can type in a new tag).

---

**NOTE** The combined value of the component tag, installation code, and location code is used for error checking in IEC mode.

---

<b>Use PLC Address</b>	Searches for a wire connection to a nearby PLC I/O address and, if found, uses the PLC address number in the tag name of the component.
<b>Tags Used: Schematic</b>	Lists used component tag names. Select a tag from the list to copy, or to increment for this new component. Initially, the list includes schematic parent components in the same family as the current component. Select to include children, all families, panel, and one-line components in the list.
<b>Tags Used: Panel</b>	Lists used panel component tag names. Select a tag from the list to copy, to this new component. An "x" in front of the tag indicates there is a schematic component already inserted. An "o" in front of the tag indicates a schematic component exists but there is mismatch on Catalog and Manufacturer values between the two.
<b>External List</b>	Assigns a tag from an external list file.
<b>Options</b>	Substitutes a fixed text string for the %F part of the tag format. Enter a tag format override in the edit box. Retag Component uses this override format value to calculate a new tag for the selected component.

## Description

Up to three lines of description attribute text can be entered.

<b>Drawing</b>	Displays a list of descriptions found in the current drawing so you can pick similar descriptions to edit.
<b>Project</b>	Displays a list of descriptions found in the project so you can pick similar descriptions to edit.
<b>Defaults</b>	Opens an ASCII text file from which you can quickly pick standard descriptions.
<b>Pick</b>	Picks a description from a component on the current drawing.

## Catalog Data

You can do a drawing-wide or project-wide listing of similar components with their catalog assignments. During your editing session, the last MFG / CAT / ASSYCODE assignment for each component type you insert into your wiring diagram is remembered. When you insert another component of that type, the previous catalog assignment of the component is set as the default (assuming a previous one was made during the current editing session).

<b>Manufacturer</b>	Lists the manufacturer number for the component. Enter a value or select one from the Catalog lookup.
<b>Catalog</b>	Lists the catalog number for the component. Enter a value or select one from the Catalog lookup.
<b>Assembly</b>	Lists the assembly code for the component. The Assembly code is used to link multiple part numbers together.
<b>Item</b>	Specifies a unique identifier assigned to each component. The tag value can be manually typed in the edit box.
<b>Count</b>	Specifies the quantity number for the part number (blank=1). This value gets inserted into the "SUBQTY" column of the BOM report.
<b>Lookup</b>	Opens the catalog database of the component from which you can manually enter or select the Manufacturer or Catalog values. Search the database for a specific catalog item to assign to the selected component.

<b>Previous</b>	Scans the previous project to find an instance of the selected component and returns the component values.
<b>Drawing</b>	Lists the part numbers used for similar components in the current drawing.
<b>Project</b>	Lists the part numbers used for similar components in the project.
<b>Multiple Catalog</b>	Inserts or edits extra catalog part numbers on to the selected component. You can add up to ten part numbers to any component. These multiple BOM part numbers appear as subassembly part numbers to the main catalog part number in the various BOM and component reports.
<b>Catalog Check</b>	Displays what the selected item looks like in a Bill of Material template.

### **Cross-Reference**

<b>Component override</b>	Overrides the WD_M block settings of the drawing with component-specific cross-reference settings. Click Setup to edit the component cross-reference settings manually.
<b>Reference NO/ Reference NC</b>	A pin list database table is consulted when a part number is added or an existing part number is changed on a parent symbol. If a match on Manufacturer, Catalog, and Assembly values in the database table of the part number is found, the associated contact count and pin number information is retrieved and placed on the parent component. Click NO/NC Setup to view or manually edit pin list data values.

### **Ratings**

Specifies values for each ratings attribute. You can enter up to 12 ratings attributes on a component. Select Defaults to display a list of default values.

---

**NOTE** If the Ratings choice is unavailable, the component you are editing does not carry rating attributes.

---

### Show/Edit Miscellaneous

View or edit any attributes that are not predefined AutoCAD Electrical attributes.

### Pins

Assigns pin numbers to the pins that are physically located on the component.

**For Connectors:** Once a connector is inserted onto the block definition of the drawing file, you can edit the connector pins found inside of the connector.

<b>Pins</b>	Displays pairs of pins in the first column, the plug pin values in the second column, and the receptacle pin values in the last column.
<b>Edit</b>	Enter a new pin number value in the edit boxes or click the arrows to either increase or decrease both plug and receptacle values by one.
<b>List</b>	Lists all the pins previously used in the project and the next available pin assignment that can be used.

## Multiple bill of material information

This tool allows you to insert or edit extra catalog part numbers on to the currently selected component or footprint. You can add up to 99 additional part numbers to any schematic or panel component on-the-fly. These multiple BOM part numbers appear as subassembly part numbers to the main catalog part number in the various BOM and component reports.

On the Insert/Edit Component or Panel Layout - Component Insert/Edit dialog box, Catalog Data section, click Multiple Catalog.

---

**NOTE** You can also access this dialog box by clicking Multiple Catalog on the [Copy Catalog Assignment](#) on page 1299 dialog box.

---

The additional catalog part numbers are saved on the symbol as MFGn/CATn/ASSYCODEn attribute values. The "n" is the sequential code value "01" through "99" selected in the top list box. If these attributes are not present on the symbols, AutoCAD Electrical saves the information as Extended Entity Data (Xdata) on the block insert.

### Sequential code

Adds up to 99 extra part numbers (in addition to the main catalog part number). Pick which one you want to add or inspect/edit. Click the list button to show all extra part numbers carried on the component.

**Catalog Data**

Specifies the catalog part number information such as the manufacturer and catalog number.

**Count**

Specifies the quantity number for the extra part number (blank=1). This value gets inserted into the "SUBQTY" column of a BOM report.

**Unit**

Specifies the unit of measure, which can be displayed in the component list report.

**Parts Catalog Lookup**

Lists the catalog database table that is to be referenced for the description information for the given Manufacturer/Catalog/Assembly combination. For each catalog entry, provide a name for the catalog look-up table. For the main catalog entry, this information is provided on the symbol itself but may not be there for these catalog entries. Select List to pick from a list of tables that are contained in your catalog database file or Misc to use the MISC\_CAT table.

**Catalog Lookup**

Checks for and displays catalog table information in the Parts Catalog dialog box for the selected component type.

**Catalog Check**

Quickly performs a Bill of Material check and displays the result.

**Item Number**

Assign an item number to the catalog number.

**fixed**

If checked, marks an item number as fixed. If you run [Resequence Item Numbers](#) on page 1602 later on, fixed item numbers do not change.

---

**NOTE** The fixed check box is available only when assigning the catalog to panel components.

---

**Drawing: Find**

Finds the assigned manufacturer, catalog, assembly code combination on components on the active drawing. If a match is found, the item number is

assigned to this catalog. If a match is not found, a dialog box displays where you enter an item number or use the next available.

---

**NOTE** If the [Item Numbering Mode](#) on page 211 is Accumulate Project Wide, this button is disabled.

---

**Drawing: List**

Lists the item numbers along with each manufacturer, catalog, assembly code combinations in use on the active drawing.

---

**NOTE** If the [Item Numbering Mode](#) on page 211 is Accumulate Project Wide, this button is disabled.

---

**Project: Find**

Finds the assigned manufacturer, catalog, assembly code combination on components on the drawings in the active project. If a match is found, the item number is assigned to this catalog. If a match is not found, a dialog box displays where you enter an item number or use the next available.

---

**NOTE** If the [Item Numbering Mode](#) on page 211 is Reset with Each Drawing, this button is disabled.

---

**Project: List**

Lists the item numbers along with each manufacturer, catalog, assembly code combinations in use on the drawings in the active project.

---

**NOTE** If the [Item Numbering Mode](#) on page 211 is Reset with Each Drawing, this button is disabled.

---

If the [Item Assignments](#) on page 211 project setting is set Per-Component Basis, this section is disabled.

## **Multiple catalog part number assignments**

This dialog box displays the order in which the extra part numbers appear in the various AutoCAD Electrical reports. You can add up to 99 additional part number assignments to a component.

On the Insert/Edit Component or Panel Layout - Component Insert/Edit dialog box, Catalog Data section, click Multiple Catalog. Click Sequential Code: List on the Multiple Bill of Material Information dialog box.

---

**NOTE** You can also access this dialog box by clicking Multiple Catalog on the [Copy Catalog Assignment](#) on page 1299 dialog box and clicking Sequential Code: List.

---

To change the order, highlight the part number and click Move Up or Move Down to move it in the list.

## Tags in use

Displays a listing of all component tags found on the schematic for the project.

### Insert Component

 **Ribbon:** Schematic tab ► Insert Components panel ► Insert

Components drop-down ► Icon Menu.



 **Toolbar:** Main Electrical

 **Menu:** Components ► Insert Component

 **Command entry:** AECOMPONENT

Select the component type to insert and specify the insertion point on the drawing. In the Insert/Edit Component dialog box, click Tags Used: Schematic.

### Edit Component

 **Ribbon:** Schematic tab ► Edit Components panel ► Edit Components

drop-down ► Edit.



 **Toolbar:** Main Electrical

 **Menu:** Components ► Edit Component

 **Command entry:** AEEDITCOMPONENT

Select the component to edit. In the Insert/Edit Component dialog box, click Tags Used:Schematic.

**Sort**

Sorts the list by component tag, drawing sequence, or description.



<b>Show parent/stand-alone references</b>	Shows all parent components for related family codes in the project. (Default)
<b>Show child references</b>	Shows the children along with the parent for related family codes in the project.
<b>Show all components for all families</b>	Shows all devices from all families in the project.
<b>Show all panel components</b>	Displays all panel components.
<b>Show one-line components</b>	Shows all one-line components for related family codes in the project.
<b>Freshen</b>	Changes the current drawing visible in the tag list and updates the data in the project database.
<b>Copy Tag</b>	Applies the selected line to the edited component.
<b>Calculate Next</b>	Provides the next available tag (sequence or line reference number) for the device type selected in the dialog box.

## Panel tag list

Displays a listing of all component tags found on the panel drawings for the project.

### Insert Component

 **Ribbon:** Schematic tab ► Insert Components panel ► Insert

Components drop-down ► Icon Menu.

 **Toolbar:** Main Electrical

 **Menu:** Components ► Insert Component

 **Command entry:** AECOMPONENT

Select the component type to insert and specify the insertion point on the drawing. In the Insert/Edit Component dialog box, click Tags Used: Panel.

### Edit Component

 **Ribbon:** Schematic tab ► Edit Components panel ► Edit Components

drop-down ► Edit.



 **Toolbar:** Main Electrical

 **Menu:** Components ► Edit Component

 **Command entry:** AEEDITCOMPONENT

Select the component to edit. In the Insert/Edit Component dialog box, click Tags Used: Panel.

<b>Sort</b>	Sorts the list by component tag, installation code, location code, or sheet number.
<b>Freshen</b>	Changes the current drawing visible in the tag list and updates the data in the project database.

### Option: tag format "family" override

AutoCAD Electrical provides a way to override a component tag but still update the reference number portion on a retag.

### Insert Component

 **Ribbon:** Schematic tab ► Insert Components panel ► Insert

Components drop-down ► Icon Menu.



 **Toolbar:** Main Electrical

 **Menu:** Components ► Insert Component

 **Command entry:** AECOMPONENT

Select the component type to insert and specify the insertion point on the drawing. In the Insert/Edit Component dialog box, click the Options button in the Component Tag area.

## Edit Component

 **Ribbon:** Schematic tab ► Edit Components panel ► Edit Components

drop-down ► Edit.



 **Toolbar:** Main Electrical

 **Menu:** Components ► Edit Component

 **Command entry:** AEEDITCOMPONENT

Select the component to edit. In the Insert/Edit Component dialog box, click the Options button in the Component Tag area.

You can substitute a fixed text string for the %F part of the tag format for a component. Retag can then use the override format value to calculate a new tag for the component. For example, a certain relay component must always have an "MC-R" family tag value instead of "CR" so that retag assigns MC-R100 instead of CR100. To achieve this tag override, enter "MC-R%N" for the tag format.

## Component annotation from external file

This tool pulls information from a selected line in an external space or comma-delimited text file and assigns its text to a specific attribute/xdata on the component. The default extension for this file is ".wdx" but can also be ".csv" or ".txt." The file format is free-form.

## Insert Component

 **Ribbon:** Schematic tab ► Insert Components panel ► Insert

Components drop-down ► Icon Menu.



 **Toolbar:** Main Electrical

 **Menu:** Components ► Insert Component

 **Command entry:** AECOMPONENT

Select the component type to insert and specify the insertion point on the drawing. In the Insert/Edit Component dialog box, click External List. Select

the .wdx, .csv, or .txt file to reference and click Open. Select a line of data from the list and click OK.

### Edit Component

 **Ribbon:** Schematic tab ► Edit Components panel ► Edit Components

drop-down ► Edit.



 **Toolbar:** Main Electrical

 **Menu:** Components ► Edit Component

 **Command entry:** AEEDITCOMPONENT

Select the component to edit. In the Insert/Edit Component dialog box, click External List. Select the .wdx, .csv, or .txt file to reference and click Open. Select a line of data from the list and click OK.

Select a value from the list of data elements on the left, then click one of the buttons next to the attribute name to assign the value to.

**Overwrite**

Overwrites the existing value in the edit box with the selected value.

**Add**

Adds the selected value to the edit box. The value is appended to any existing value.

### Descriptions

Standard Description lists can be created in ASCII text files with a .WDD file extension. You may create project-related list, component family lists, a generic list, or any type of description list.

 **Ribbon:** Schematic tab ► Edit Components panel ► Edit Components

drop-down ► Edit.



 **Toolbar:** Main Electrical

 **Menu:** Components ► Edit Component

 **Command entry:** AEEDITCOMPONENT

Select the component to edit. Click Defaults in the Description section of the Insert/Edit Component dialog box.

Highlight an entry from the list and click OK, or click Pick File to select a different file and description list.

<b>Descriptions panel</b>	Displays the values for the description file.
<b>Pick File</b>	Selects a different file and description list.
<b>Language</b>	Displays the Language Database file (WD_LANG1.MDB) for the AutoCAD Electrical Language Conversion tool.
<b>Project</b>	Displays a project .wdd file (if not already displayed).
<b>Family</b>	Displays a family .wdd file (if not already displayed). For example, if the component has the family code "PB" for push buttons and a file called PB.WDD exists, it displays when you click Family.
<b>General</b>	Displays a generic file (WD_DESC.WDD) if not already displayed.
<b>Add/Edit</b>	Opens a dialog box for adding or editing description text (DESC1, DESC2, and DESC3) for the file. Enter a value or click Edit File to edit the file using WordPad.
<b>OK-Description 1</b>	Inserts the selected text into line Description 1. Any existing text in description lines 2 and 3 is left untouched (for example, inserting dual language descriptions).
<b>OK-Description 2</b>	Inserts the selected text into line Description 2. Any existing text in description lines 1 and 3 is left untouched.
<b>OK-Description 3</b>	Inserts the selected text into line Description 3. Any existing text in description lines 1 and 2 is left untouched.



## Select description from AutoCAD Electrical language table

Opens the current language table for review. The default table is wd\_lang1.mdb

 **Ribbon:** Schematic tab ► Edit Components panel ► Edit Components

drop-down ► Edit. 



-  **Toolbar:** Main Electrical
-  **Menu:** Components ► Edit Component
-  **Command entry:** AEEDITCOMPONENT

Select the component to edit. Click the Defaults button in the Description section of the Insert/Edit Component dialog box, and click Language.

---

**NOTE** Use the [Edit Language Database File](#) on page 1203 tool to modify the language table.

---

<b>Select language</b>	Selects a predefined language. <hr/> <b>NOTE</b> Language matches are not case sensitive, but phrase substitutions are made exactly as entered in the language table. <hr/>
<b>Phrase list in selected language</b>	Displays a phrase list for the selected language.
<b>Pick language/Phrase to use</b>	Specifies which language to use for the selected phrase.
<b>Pick File</b>	Selects a different file and description list.
<b>Project</b>	Displays a project .wdd file (if not already displayed).
<b>Family</b>	Displays a family .wdd file (if not already displayed). For example, if the component has the family code "PB" for push buttons and a file called PB.WDD exists, it displays when you click Family.
<b>Generic</b>	Displays a generic file (WD_DESC.WDD) if not already displayed.

### Select description text format

Specifies how to handle description text in the selected language.

-  **Ribbon:** Schematic tab ► Edit Components panel ► Edit Components



drop-down ► Edit.



 **Toolbar:** Main Electrical

 **Menu:** Components ► Edit Component

 **Command entry:** AEEDITCOMPONENT

Select the component to edit. In the Insert/Edit Component dialog box, Description section, click Defaults. In the Descriptions dialog box, click Language. Select the phrase and language to edit and click OK.

<b>1 Line, 2 Lines, 3 Lines</b>	Specifies whether to display the selected description text in one line or across multiple lines. Examples of what the description looks like appear next to the options.
<b>Manual edit/override</b>	Overrides the selected description text. You can use the default text or type modifications in the edit box. The " " character forces a line break.
<b>OK ► Description 1</b>	Inserts selected description text into the first description text line of the component, leaving any existing text in lines 2 and 3 as is. However, if you selected two Lines above and click OK ► Description 1, the description text displays in description lines 1 and 2 in the Insert/Edit Component dialog box.
<b>OK ► Description 2</b>	Inserts selected description text into the second description text line of the component, leaving any existing text in lines 1 and 3 as is.
<b>OK ► Description 2,3</b>	Inserts text starting at the second description text line of the component, leaving any existing text in the first line as is.

---

**NOTE** These components are useful for inserting description text in dual languages.

---

### **Pin numbers in use**

Lists all the pins previously used in the project and the available pins that can be assigned to a component. The component tag displays below the title bar in the dialog box.

 **Ribbon:** Schematic tab ► Edit Components panel ► Edit Components

drop-down ► Edit. 

 **Toolbar:** Main Electrical

 **Menu:** Components ► Edit Component

 **Command entry:** AEEDITCOMPONENT

Select the component to edit. In the Insert/Edit Component dialog box, Pins section, click List.

<b>Pin List</b>	The three lists display all available pins to assign to the component. The number in parenthesis () indicates the single or pair of pins for the component. Pins can be Unused NO Pairs, Unused Form-C contacts, and undefined.
<b>Sheet, Reference</b>	Displays the sheet number and potential reference line number where the connector definition is located in the project.
<b>Type</b>	Displays the contact type (for example, "NO" or "NC"). It is the value carried by the CONTACT attribute of the component. If no attribute is present or this attribute is blank, then this field is blank.
<b>Pins</b>	Displays the pin numbers already in use in the project.
<b>Wire Numbers</b>	Displays the wire numbers carried on wires attached to each of the pins above. If no wire connection to the pin, or if the wire does not carry a wire number assignment, then this field is blank.

## Insert or edit child components

### Insert or edit child component



#### Insert Component

 **Ribbon:** Schematic tab ► Insert Components panel ► Insert

Components drop-down ► Icon Menu. 





-  **Toolbar:** Main Electrical
-  **Menu:** Components > Insert Component
-  **Command entry:** AECOMPONENT

Select the child component type to insert and specify the insertion point on the drawing.



### Multiple Insert (Icon Menu)

-  **Ribbon:** Schematic tab > Insert Components panel > Multiple Insert



drop-down > Multiple Insert (Icon Menu).



-  **Toolbar:** Main Electrical
-  **Menu:** Components > Multiple Insert > Multiple Insert (Icon Menu)
-  **Command entry:** AEMULTI

Select the child component type to insert and select the fence points on the drawing for insertion at each point where the fence crosses an underlying wire.



### Edit Component

-  **Ribbon:** Schematic tab > Edit Components panel > Edit Components



drop-down > Edit.



-  **Toolbar:** Main Electrical
-  **Menu:** Components > Edit Component
-  **Command entry:** AEEDITCOMPONENT

Select the child component to edit.

You can go back to any component at any time and make changes.

## Component Tag

The parent tag value can be manually typed into the edit box or selected from a drawing-wide or project-wide list of similar components. If the parent is visible on the screen, click Parent/Sibling and select the parent (or another related contact). This transfers all information automatically to the child contact being inserted or edited.

---

**NOTE** Only components of the same category are displayed in the Drawing or Project lists. For example, if the child is a one-line component, only one-line components are listed. The category for a component is defined by the [WDTYPE attribute](#) on page 325 value. If this attribute is missing or blank, category "schematic" is assumed.

---

## Catalog Data

If the child component does not have MFG and CAT attributes, this section is not included on the dialog box.

<b>Manufacturer</b>	Lists the manufacturer number for the component. Enter a value or select one from the Catalog lookup.
<b>Catalog</b>	Lists the catalog number for the component. Enter a value or select one from the Catalog lookup.
<b>Assembly</b>	Lists the assembly code for the component. The Assembly code is used to link multiple part numbers together.
<b>Item</b>	Specifies a unique identifier assigned to each component. The tag value can be manually typed in the edit box.
<b>Count</b>	Specifies the quantity number for the part number (blank=1). This value gets inserted into the "SUBQTY" column of the BOM report.
<b>Lookup</b>	Opens the catalog database of the component from which you can manually enter or select the Manufacturer or Catalog values. Search the database for a specific catalog item to assign to the selected component.
<b>Previous</b>	Scans the previous project to find an instance of the selected component and returns the component values. You can then make your catalog assignment by picking from the dialog box list.

<b>Drawing</b>	Lists the part numbers used for similar components in the current drawing.
<b>Project</b>	<p>Lists the part numbers used for similar components in the project. You can search in the active project, another project, or an external file.</p> <ul style="list-style-type: none"> <li>■ <b>Active project:</b> All the drawings in the current project are scanned and the results are listed in a dialog box. Select from the list to assign your new component with a catalog number that is consistent with other similar components in the project.</li> <li>■ <b>Other project:</b> Scans each listed drawing in a previous project for the target component type and returns the catalog information in a subdialog box. Make your catalog assignment by picking from the dialog box list.</li> <li>■ <b>External file:</b> You can pull catalog assignments from a generic ASCII file created by a word processor or output from a spreadsheet or database program. A dialog box displays the contents of the selected text file. Find and highlight the appropriate entry. AutoCAD Electrical reads the line of text from the file and breaks it into its component parts. They are displayed in the left-hand dialog box list. For each relevant item, highlight it, and then pick the appropriate category button in the center column. The highlighted item is transferred to the corresponding category (and then to the Insert/Edit dialog box once OK is clicked).</li> </ul>
<b>Multiple Catalog</b>	Inserts or edits extra catalog part numbers on to the selected component. You can add up to 99 part numbers to any component. These multiple BOM part numbers appear as sub-assembly part numbers to the main catalog part number in the various BOM and component reports.
<b>Catalog Check</b>	Displays what the selected item looks like in a Bill of Material template.

### **Ratings**

Specifies values for each ratings attribute. You can enter up to 12 ratings attributes on a component. Select Defaults to display a list of default values.

---

**NOTE** If Ratings is grayed out, the component you are editing does not carry rating attributes.

---

### **Description**

Up to 3 lines of description attribute text can be entered. These lines are automatically filled with a copy of the parent's description text if the parent Tag name is picked using one of the methods above. You can enter descriptions or select a description from a component on the current drawing.

### **Cross-reference**

AutoCAD Electrical automatically fills in cross-reference text when the cross-reference command is run.

---

**NOTE** If the Cross-reference edit box is grayed out, the component you are editing does not carry an XREF attribute.

---

### **Installation Code**

Changes the installation code(s). You can search the current drawing or entire project for installation codes. AutoCAD Electrical does a quick read of all the current or selected drawing files and returns a list of all installation codes used so far. Pick from the list to automatically update the component with the installation code.

Assigning short installation codes to components like "PNL" and "FIELD" allow you to later create installation-specific BOM and component lists.

### **Location Code**

Changes the location code(s). You can search the current drawing or entire project for location codes. A quick read of all the current or selected drawing files is done and a list of location codes used so far is returned. Pick from the list to automatically update the component with the location code.

Assigning short location codes to components like "PNL" and "FIELD" allow you to later extract cable from/to reports and location-specific BOM reports (ex: BOM for all field cables, BOM for all PNL cables).

### **Show/Edit Miscellaneous**

View or edit any attributes that are not predefined AutoCAD Electrical attributes.

## Pins

Assigns pin numbers to the pins that are physically located on the component.

## OK-Repeat

(not available when editing components) Inserts the new component onto the drawing and then inserts another 'just like' component.

## Insert or edit child component: IEC

This is Insert/Edit Child Component dialog box for working in IEC mode. If you are working in JIC mode, the dialog box will display differently.

### Insert Component

 **Ribbon:** Schematic tab ► Insert Components panel ► Insert

Components drop-down ► Icon Menu.



 **Toolbar:** Main Electrical

 **Menu:** Components ► Insert Component

 **Command entry:** AECOMPONENT

Select the child component type to insert and specify the insertion point on the drawing.

### Multiple Insert (Icon Menu)

 **Ribbon:** Schematic tab ► Insert Components panel ► Multiple Insert

drop-down ► Multiple Insert (Icon Menu).



 **Toolbar:** Main Electrical

 **Menu:** Components ► Multiple Insert ► Multiple Insert (Icon Menu)

 **Command entry:** AEMULTI

Select the child component type to insert and select the fence points on the drawing for insertion at each point where the fence crosses an underlying wire.

## Edit Component

 **Ribbon:** Schematic tab ► Edit Components panel ► Edit Components

drop-down ► Edit.



 **Toolbar:** Main Electrical

 **Menu:** Components ► Edit Component

 **Command entry:** AEEDITCOMPONENT

Select the child component to edit.

You can go back to any component at any time and make changes.

## Installation

Changes the installation codes. You can search the current drawing or entire project for installation codes. A quick read of all the current or selected drawing files is done and a list of installation codes used so far is returned. Select from the list to automatically update the component with the installation code.

Assign short installation codes to components like "PNL" and "FIELD" so you can create installation-specific BOM and component lists later.

## Location

Changes the location codes. You can search the current drawing or entire project for location codes. A quick read of all the current or selected drawing files is done and a list of location codes used so far is returned. Select from the list to automatically update the component with the location code.

Assign short location codes to components like "PNL" and "FIELD" so you can extract cable from/to reports and location-specific BOM reports later. (For example, BOM for all field cables, BOM for all PNL cables.)

## Component Tag

The parent tag value can be manually typed into the edit box or selected from a drawing-wide or project-wide list of similar components. If the parent is visible on the screen, Click Parent/Sibling and select the parent (or another related contact). This transfers all information automatically to the child contact being inserted or edited.

---

**NOTE** Only components of the same category are displayed in the Drawing or Project lists. For example, if the child is a one-line component, only one-line components are listed. The category for a component is defined by the [WDTYPE attribute](#) on page 325 value.

---

### Description

Up to 3 lines of description attribute text can be entered. These lines are automatically filled with a copy of the parent's description text if the parent Tag name is picked using one of the methods described previously. You can enter descriptions or select a description from a component on the current drawing.

### Catalog Data

If the child component does not have MFG and CAT attributes, this section is not included on the dialog box.

<b>Manufacturer</b>	Lists the manufacturer number for the component. Enter a value or select one from the Catalog lookup.
<b>Catalog</b>	Lists the catalog number for the component. Enter a value or select one from the Catalog lookup.
<b>Assembly</b>	Lists the assembly code for the component. The Assembly code is used to link multiple part numbers together.
<b>Item</b>	Specifies a unique identifier assigned to each component. The tag value can be manually typed in the edit box.
<b>Count</b>	Specifies the quantity number for the part number (blank=1). This value gets inserted into the "SUBQTY" column of the BOM report.
<b>Lookup</b>	Opens the catalog database of the component from which you can manually enter or select the Manufacturer or Catalog values. Search the database for a specific catalog item to assign to the selected component.
<b>Previous</b>	Scans the previous project to find an instance of the selected component and returns the component values. You can then make your catalog assignment by picking from the dialog box list.

<b>Drawing</b>	Lists the part numbers used for similar components in the current drawing.
<b>Project</b>	<p>Lists the part numbers used for similar components in the project. You can search in the active project, another project, or an external file.</p> <ul style="list-style-type: none"> <li>■ <b>Active project:</b> All the drawings in the current project are scanned and the results are listed in a dialog box. Select from the list to assign your new component with a catalog number that is consistent with other similar components in the project.</li> <li>■ <b>Other project:</b> Scans each listed drawing in a previous project for the target component type and returns the catalog information in a subdialog box. Make your catalog assignment by picking from the dialog box list.</li> <li>■ <b>External file:</b> You can pull catalog assignments from a generic ASCII file created by a word processor or output from a spreadsheet or database program. A dialog box displays the contents of the selected text file. Find and highlight the appropriate entry. AutoCAD Electrical reads the line of text from the file and breaks it into its component parts. They are displayed in the left-hand dialog box list. For each relevant item, highlight it, and then pick the appropriate category button in the center column. The highlighted item is transferred to the corresponding category (and then to the Insert/Edit dialog box once OK is clicked).</li> </ul>
<b>Multiple Catalog</b>	Inserts or edits extra catalog part numbers on to the selected component. You can add up to 99 part numbers to any component. These multiple BOM part numbers appear as sub-assembly part numbers to the main catalog part number in the various BOM and component reports.
<b>Catalog Check</b>	Displays what the selected item looks like in a Bill of Material template.

### **Ratings**

Specifies values for each ratings attribute. You can enter up to 12 ratings attributes on a component. Select Defaults to display a list of default values.



---

**NOTE** If Ratings is grayed out, the component you are editing does not carry any rating attributes.

---

### Show/Edit Miscellaneous

View or edit any attributes that are not predefined AutoCAD Electrical attributes.

### Cross-reference

AutoCAD Electrical automatically fills in cross-reference text when the cross-reference command is run.

---

**NOTE** If the Cross-reference edit box is grayed out, the component you are editing does not carry an XREF attribute.

---

### Pins

Assigns pin numbers to the pins that are physically located on the component.

## Insert a copy of a component

### Insert a copy of an existing component

Copies a component you select in a drawing to a point you specify, and includes automatic update of the component tag.

A copied component automatically breaks any underlying wires. You can edit the component values brought over from the original component.

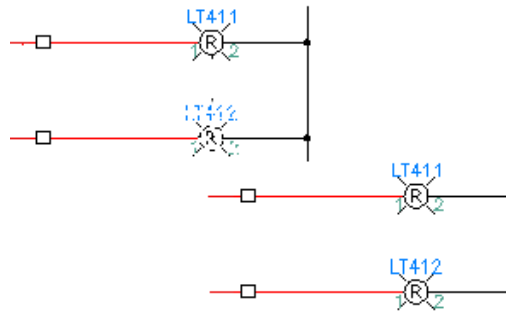

- 1 Click Schematic tab ► Insert Components panel ► Copy Component.



- 2 Select a component from the drawing just like the new one you want to insert.
- 3 Select the insertion point.  
This inserts a copy of the symbol you selected and then displays the Insert/Edit Component dialog box, so you can finish annotating the component.
- 4 Click OK.

### Insert similar components at fence crossing points

Inserts a component selected from the icon menu at points where the fence you define crosses a wire.

Each point where the fence crosses a wire is an optional insertion point. The operation inserts each component and breaks any underlying wires. You can edit the component values.

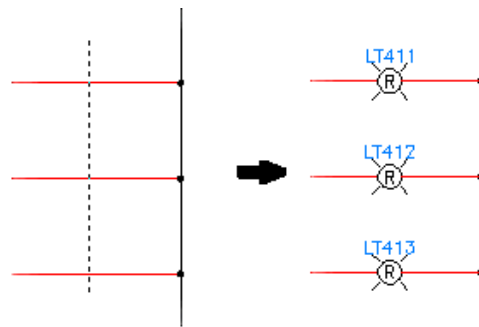

- 1 Click Schematic tab ► Insert Components panel ► Multiple Insert



drop-down ► Multiple Insert (Icon Menu).

- 2 Select the component type from the Insert Component: Schematic Symbols dialog box.
- 3 Select the component from the selection dialog box.

- 4 Select a point above the first wire that you want to process.
- 5 Select a point below the final wire for processing, and then right-click to end the command.
- 6 With each possible insertion point (that is, fence crossing point with a wire) a dialog box displays, prompting you to decide whether to keep the insertion, keep all of the insertions, or skip to the next one.  
If you keep the insertion point, the regular Insert/Edit dialog box is displayed, where you finish annotating the component.
- 7 Click OK to complete the operation.

### Copy a component to fence crossing points

Inserts copies of a selected component at each point where a defined fence crosses a wire.

With each possible insertion point, specify whether to keep the insertion, keep all the insertions, or skip to the next one.

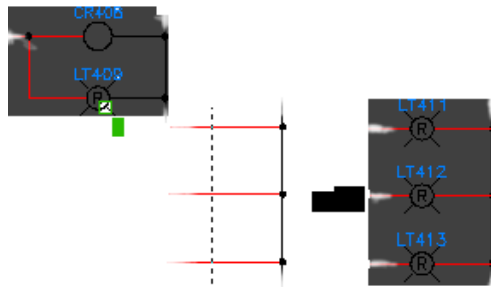

- 1 Click Schematic tab ► Insert Components panel ► Multiple Insert



drop-down ► Multiple Insert (Pick Master).

- 2 Select the component to copy.
- 3 Select a point above the first wire that you want to process.
- 4 Select a point below the final wire for processing, and then right-click to end the command.

- 5 With each possible insertion point (that is, fence crossing point with a wire) a dialog box displays. Specify whether to keep the insertion, keep all of the insertions, or skip to the next one.  
If you keep the insertion point, the regular Insert/Edit dialog box is displayed, where you finish annotating the component.
- 6 Click OK to complete the operation.

## Insert from catalog lists

### Insert components from catalog lists

Use this to annotate the selected schematic (or panel) component with the catalog number or a component description selected from a user-defined pick list and insert it into the drawing.

---

**NOTE** This procedure uses schematic tools, but the same procedure can be done using panel tools.

---

- 1 Click Schematic tab ► Insert Components panel ► Insert Components



drop-down ► Catalog List.

- 2 Sort the component list by catalog, description, or manufacturer.
- 3 Select the component to insert.
- 4 (Optional) Click Edit to make any changes to the catalog record. Modify the record in the Edit Record dialog box and click OK.
- 5 (Optional) Click Add to create a new record. If the new record is similar to an existing record, highlight the existing record before you click Add. Modify the record in the Add Record dialog box and click OK.
- 6 Click OK.
- 7 Specify an insertion point in the active drawing.
- 8 Make any changes in the Insert/Edit Component dialog box and click OK.

### Schematic component or panel footprint

Inserts schematic or panel symbols by choosing a catalog number or a component description from a user-defined pick list. The data displayed in this pick list is stored in a database in generic Access format. The file name is *wd\_picklist.mdb* and can be edited with Access or from Add/Edit/Delete along the bottom of the dialog box for the pick list. The AutoCAD Electrical normal search path sequence is used to locate this file.

### Insert Component (Catalog List)

 **Ribbon:** Schematic tab ► Insert Components panel ► Insert Components

drop-down ► Catalog List.



 **Toolbar:** Insert Component

 **Menu:** Components ► Insert Component (Lists) ► Insert Component (Catalog List)

 **Command entry:** AECOMPONENTCAT

### Insert Footprint (Catalog List)

 **Ribbon:** Panel tab ► Insert Component Footprints panel ► Insert

Footprints drop-down ► Catalog List.



 **Toolbar:** Insert Footprint (Lists)

 **Menu:** Panel Layout ► Insert Footprint (Lists) ► Insert Footprint (Catalog List)

 **Command entry:** AEFOOTPRINTCAT

Both schematic and panel layout symbols can be included in the pick list database. Only schematic or panel entries are displayed at a time depending on whether the routine is called from the AutoCAD Electrical or Panel Layout toolbar.

**Sort by**

Specifies how to sort the record list. You can sort by description, catalog number, or manufacturer code.

**Add**

Opens a dialog box for creating a record. If the footprint block is not in an AutoCAD or an AutoCAD Electrical search path, include the part

of the path to append to one of these search paths (or you can enter the full path). If the new record is like an existing record, highlight the existing record before you click Add.

- Edit** Opens a dialog box for editing a record. Highlight the record and click Edit. Modify the record in the displayed dialog box.
- Delete** Removes an existing record.

## Add or edit record

### Insert Component (Catalog List)

 **Ribbon:** Schematic tab ► Insert Components panel ► Insert Components

drop-down ► Catalog List.



 **Toolbar:** Insert Component

 **Menu:** Components ► Insert Component (Lists) ► Insert Component (Catalog List)

 **Command entry:** AECOMPONENTCAT

Click Add or Edit.

### Insert Footprint (Catalog List)

 **Ribbon:** Panel tab ► Insert Component Footprints panel ► Insert

Components drop-down ► Catalog List.



 **Toolbar:** Insert Footprint (Lists)

 **Menu:** Panel Layout ► Insert Footprint (Lists) ► Insert Footprint (Catalog List)

 **Command entry:** AEFOOTPRINTCAT

Click Add or Edit.

---

**NOTE** When you add a record you must indicate if the component or circuit is Schematic or Panel and you need to indicate if it should be inserted as a block or exploded upon insert (as you would for a circuit). Then, at a minimum, you need to define the block name and either the catalog number or description.

---

### Select Schematic or Panel Device

Specifies if the component (or circuit) is Schematic or Panel.

### Single block or explode on insert

Specifies if it should be inserted as a block or exploded upon insert (as you would for a circuit).

### Minimum of Block Name and either Description or Catalog

- **Block/Assembly/Circuit:** The Block value can be a symbol name or AutoLISP expression. If the footprint block is not in an AutoCAD search path or an AutoCAD Electrical search path, include the part of the path that needs to be appended to one of these search paths (or enter the full path to the footprint block). Use Browse to locate the block name.
- **Description:** Specifies the optional comment for the footprint record. This is for reference in this file only. It does not get extracted into any AutoCAD Electrical report
- **Catalog:** (not used for exploded inserts) The Catalog value may contain wildcards. Wildcard characters include:
  - \* = match any characters
  - ? = match any single character
  - # = match any single numeric digit
  - @ = match any single alphabetic character

---

**NOTE** If the catalog number actually has a character in it like #, then precede it with the ` char, example "F120#10" would be "F120`#10"

---

### Optional Values

(These options are not available for exploded inserts) Options for specifying the manufacturer code, assembly code, and text values. If the catalog information includes an ASSYCODE value, include it in the record to ensure a complete match. If the same footprint is used no matter what the ASSYCODE value is (ex: different combinations of contact blocks on a base relay) then use "\*" wildcard character for the ASSYCODE value in the record.

The TEXTVALS value can be used to filter your pick list based on the component's FAMILY code value. For this to work, the text substring "FAMILY=<family code>" needs to be somewhere in each line of text to be displayed. The TEXTVALS field can also be used to auto-fill attribute values on insertion. For example, if the line includes the substring "MFG=AB;CAT=1492;LOC=PNL1" then the MFG, CAT, and LOC edit boxes will auto-fill with the values "AB", "1492", and "PNL1" respectively.

## The schematic lookup file

The schematic lookup file maps catalog information from a panel component or equipment list to a specific schematic component library symbol. AutoCAD Electrical supplies a starter lookup file called schematic\_lookup.mdb in Access ".mdb" file format. Within the database file are tables based on Manufacturer codes. When you select a panel footprint from an AutoCAD Electrical extract file or select a panel footprint from a catalog lookup file, it carries a manufacturer code, on the MFG attribute. AutoCAD Electrical takes this MFG code, goes to the matching table name in the schematic lookup database and tries to find a match on the manufacturer, catalog number and assembly code (if non-blank). If a match is found, AutoCAD Electrical retrieves the component block path/name (or AutoCAD Electrical command list) from the matching record and inserts the schematic component representation into the drawing.

You must expand and modify these tables to meet your specific schematic needs. You can do this using tools provided with AutoCAD Electrical or through the use of a database program that can read/write the Access file format. You may use the MDB file (schematic\_lookup.mdb) or a project-specific schematic lookup file, called <project>\_schematic\_lookup.mdb. If the project-specific .mdb file is used, it needs to be in the same subdirectory as the <project>.wdp file.

**Lookup file naming convention:** AutoCAD Electrical takes the target footprint's MFG code and looks for a table, in your Access schematic\_lookup.mdb file with that name. For example, if the footprint's MFG value is SQD, then AutoCAD Electrical searches for a schematic lookup table called SQD; manufacturer code of AB yields the table name AB.

### Lookup file format

All fields contain characters except for RECNUM, which is automatically numbered in the list for you. Fields may be blank and may use wildcards, with



the exception of SCHEMATIC\_BLKNAM. Each record consists of these fields (in this order):

<b>MANUFACTURER</b>	Manufacturer name (same as attribute value)
<b>CATALOG</b>	Catalog part number
<b>ASSEMBLYCODE</b>	Assembly code part number link
<b>FUNCTION_DESCRIPTION</b>	Assigned description text (DESC1-DESC3)
<b>PANEL_BLKNAM</b>	Block name of the panel footprint insert
<b>CATEGORY</b>	Blank for component queries, 'T' or 'W' for terminal queries
<b>WDBLKNAM</b>	Name used to tie into catalog lookup table (ex. PB11, CR)
<b>SCHEMATIC_BLKNAM</b>	Schematic symbol block name or special insert command flag
<b>COMMENTS</b>	Description of the schematic block name
<b>RECNUM</b>	Record number (automatically numbered in the list)

### Table query sequence

Queries on this database can be multi-level until a hit is returned. The first level is a query on the MFG/CAT/ASSYCODE fields. If 0 records are returned, a second query is done on just the CATALOG field (or the CATEGORY field if working with terminals). If 0 records are returned, a third query is done on the WDBLKNAM field. If this fails to return any records, a final query is made on keywords in the FUNCTION\_DESCRIPTION field.

---

**NOTE** When querying panel terminals, the second query is on the CATEGORY field, which contains a 'T' or 'W'. This query determines which symbols to display in the Insert dialog box. The 'T' displays a list of terminal symbols for terminal numbers, while the 'W' displays a list of terminal symbols for wire number terminals.



---

When multiple block name choices are returned, they are displayed in a pick list along with any comments from each matching record. If a match is not

found or if matches are found and you choose not to use any of them, the displayed Insert dialog box offers several other options. You can:

- Pick from AutoCAD Electrical's icon menu
- Browse to the symbol file (available from the icon menu)
- Enter a symbol name into the edit box (available from the icon menu)
- Pick a 'just like schematic component to get the schematic block name

## Edit schematic lookup files

- 1 Click Schematic tab ➤ Other Tools panel ➤  ➤ Database Editors  
drop-down ➤ Schematic Database File Editor. 
- 2 (Optional) Click Sort to sort the database fields so that you can quickly find the record you are looking for.
- 3 (Optional) Click Find or Replace to jump to the next occurrence of the specified text or to replace the existing text.
- 4 (Optional) Click Filter to filter the listing based on certain values in the table. After you define the values to filter, apply the filter in the database editing window.
- 5 Decide if you want to edit an existing record or add a new one.
  - If you decide to edit an existing record, select the record to edit and click Edit on the Edit dialog box or double-click the record in the list.
  - If you decide to add a new record, click Add New or Add Copy on the Edit dialog box.
- 6 Add or edit the record values and click OK.  
Your new record is added to the list. You can also immediately see any changes you made to an existing record.
- 7 Click Save/Exit.

## Edit

Use this tool to add or modify records in the schematic\_lookup.mdb file to use for mapping panel footprints and terminal representations to the equivalent schematic component block names.

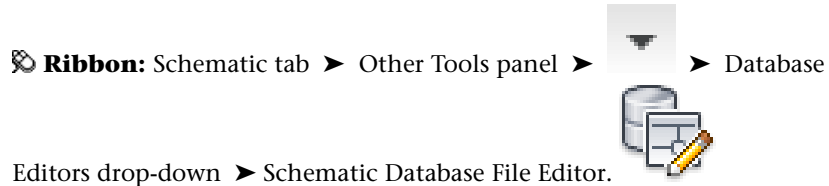

**Toolbar:** Panel Miscellaneous

**Menu:** Panel Layout > Database File Editor > Schematic Database File Editor

**Command entry:** AESCHEMATICDB

This lookup database table is a catalog lookup Access .mdb file that can be expanded as needed. Use either Microsoft Access or this dialog box to add new entries, edit or delete entries from the table.



<b>Sort</b>	Sorts the list of database records using either an alphanumeric sort or number values. You can specify four sorts to perform on the list.
<b>Find</b>	Specifies the value to find and then jumps to the next occurrence of the specified text. This searches in a specific column or in the entire table.
<b>Replace</b>	Indicates to replace the find value with the new text string that you specify.
<b>Filter</b>	Filters the listing based on certain values in the table. Picking the blank entry in the list removes the filter for that field. After you define the values to filter, apply the filter in the database editing window.
<b>Edit</b>	Displays the Edit Record dialog box for modifying the existing record in the database.
<b>Add New</b>	Displays the Edit New Record dialog box for entering a new record into the database.
<b>Add Copy</b>	Displays the Edit Copied Record dialog box for modifying and copying the record to make a new record. You cannot have two duplicate copies in the database.

**Delete**

Removes the selected record from the database.

## Edit record

Edit new, existing, or copied records in the schematic\_lookup.mdb database.

 **Ribbon:** Schematic tab ► Other Tools panel ►  ► Database

Editors drop-down ► Schematic Database File Editor. 

 **Toolbar:** Panel Miscellaneous

 **Menu:** Panel Layout ► Database File Editor ► Schematic Database File Editor

 **Command entry:** AESCHEMATICDB

Click Add New, Add Copy, or Edit or double-click on a record in the Edit dialog box.

<b>MANUFACTURER</b>	Manufacturer name (same as attribute value)
<b>CATALOG</b>	Catalog part number
<b>ASSEMBLYCODE</b>	Assembly code part number link
<b>FUNCTION_DESCRIPTION</b>	(Optional) Assigned description text (DESC1-DESC3)
<b>PANEL_BLKNAM</b>	Block name of the panel footprint insert
<b>CATEGORY</b>	Blank for component queries, 'T' or 'W' for terminal queries
<b>WDBLKNAM</b>	Name used to tie into catalog lookup table (ex. PB11, CR)
<b>SCHEMATIC_BLKNAM</b>	Schematic symbol block name or special insert command flag. Click Command List to add a command rather than a single block name.
<b>COMMENTS</b>	Description of the schematic block name

## Insert from equipment lists

This tool lists BOM data extracted from your equipment list and finds the appropriate schematic symbol by querying the [schematic\\_lookup.mdb](#) on page 780. It inserts the schematic components at your pick point. Each line or record in the equipment list represents a single entry into the Equipment in dialog box for schematic component selection. The quantity for a selected catalog number is not considered when inserting schematic components.

### Insert components from equipment lists

Use this to annotate the selected schematic (or panel) component with the panel footprint or equipment list data and insert it into the drawing.

---

**NOTE** This procedure uses schematic tools, but the same procedure can be done using panel tools.

---

- 1 Click Schematic tab ► Insert Components panel ► Insert Components



drop-down ► Equipment List.

- 2 Select the spreadsheet file to use and click Open.
- 3 If multiple sheets/tables were found in the data file, select the table to edit.
- 4 Click OK.
- 5 On the Settings dialog box, determine whether to use the default settings or select a file of previously saved settings.
  - **Default Settings:** The View/Edit Settings options become available to modify the default settings. Modify the settings or click OK to continue with the insert using the default settings.
  - **Read Settings:** Select the file (\*.wde) to read the settings from and click Open.
- 6 (Optional) Click Spreadsheet/Table columns to define the order of the data in the selected equipment list file.

On the Equipment List Spreadsheet Settings dialog box, assign column numbers to the data categories (such as Manufacturer, Catalog, and Installation).
- 7 (Optional) Click Save Settings to save the settings to a file for later recall.

- 8 On the Settings dialog box, click OK.
- 9 In the Schematic equipment in (or the Panel equipment in) dialog box, review the components by sorting or performing a catalog check.
- 10 Select the component to insert on the drawing.
- 11 Make any changes to the scale, orientation, or rotation angle for the component.
- 12 Select the method for inserting the component into the drawing:
  - **Insert:** Finds and inserts a schematic (or panel) component for the highlighted equipment list component.
  - **Pick File:** Picks a file for the insert. Select an existing AutoCAD Electrical extracted equipment list component list file or extract a fresh copy of panel component data from the database for the current project.
  - **Convert Existing:** (for Panel components only) Inserts the data for the selected entry on an existing non-AutoCAD Electrical block insert. This instantly converts the block to a smart AutoCAD Electrical footprint.
- 13 In the Insert dialog box, select the block name to insert from the list.
- 14 Click OK.

## Settings

This spreadsheet organizes the selected user-created equipment list and presents the list in a pick list. As you pick an item from the pick list, the appropriate schematic symbol is found and inserted in the drawing at your pick point. Your equipment list can be an AutoCAD Electrical-generated Component report, or it can be a list of motors giving horsepower and starter type along with motor ID and descriptions.

---

**NOTE** You can open a comma-delimited file, Excel spreadsheet, or Access database file for input.

---

### Insert Component (Equipment List)

 **Ribbon:** Schematic tab ► Insert Components panel ► Insert Components



drop-down ► Equipment List.



**Toolbar:** Insert Component (Lists)

**Menu:** Components ► Insert Component (Lists) ► Insert Component (Equipment List)

**Command entry:** AECOMPONENTEQ

Select the spreadsheet file to use and click Open. Click the table to edit and click OK.

### Insert Footprint (Equipment List)

**Ribbon:** Panel tab ► Insert Component Footprints panel ► Insert



Footprints drop-down ► Equipment List.



**Toolbar:** Insert Footprint (Lists)

**Menu:** Panel Layout ► Insert Footprint (Lists) ► Insert Footprint (Equipment List)

**Command entry:** AEFOOTPRINTEQ

Select the spreadsheet file to use and click Open. Click the table to edit and click OK.

<b>Default settings</b>	Uses the default settings for managing equipment lists.
<b>Read settings</b>	Reads and uses the settings for a previously saved file.
<b>Spreadsheet/Table columns</b>	Defines the order of the data in the selected equipment list file. Assign column numbers to data categories (such as Manufacturer, Catalog, and Installation) in the Equipment List Spreadsheet Settings dialog box.
<b>Save settings</b>	Saves the column information in a text file for reuse. The filename is user-defined with the extension <i>.wde</i> .

## Schematic equipment in

You can select to insert a single schematic component or multiple components from the equipment list.

 **Ribbon:** Schematic tab ► Insert Components panel ► Insert Components

drop-down ► Equipment List.

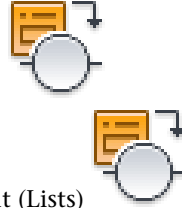

 **Toolbar:** Insert Component (Lists)

 **Menu:** Components ► Insert Component (Lists) ► Insert Component (Equipment List)

 **Command entry:** AECOMPONENTEQ

Select the spreadsheet file to use and click Open. Specify to use default or previously saved settings and click OK.

### Sort List

Sorts the list of components. You can specify four sorts to perform on the list.

### Catalog Check

Performs a Bill of Material check and displays the result. This is enabled if the selected equipment list item contains catalog data.

### TAG Options

Specifies whether to use the component tag as listed in the equipment list or recalculate the schematic tag based on the tagging settings of the drawing.

When a component that doesn't have a tag is selected from the list, this switch is automatically set to Use auto-generated schematic TAG.

**Use auto-generated schematic TAG**

Modifies the schematic component tag based upon the drawing settings.

**Use Equipment List TAG**

Maintains the tag as defined in the component listing and sets the tag to fixed in the schematic.

### Scale

Specifies the block insert scale. (1.0 = full)

### Vertical/Horizontal

Changes the default drawing orientation.



### **Insert**

Finds and inserts a schematic component for the highlighted equipment list component. The query of the schematic\_lookup.mdb file returns one or more block names based on data that appears in the pick list. The results are displayed in the Insert dialog box along with a short description of each choice.

### **Pick File**

Picks a file for the insert. Select an existing AutoCAD Electrical extracted equipment list component list file or extract a fresh copy of panel component data from the current project's database.

### **Insert**

This dialog box displays the result of a query on the schematic\_lookup.mdb file. Select the appropriate block to insert from the list and click OK. The selected schematic component is then annotated with the panel footprint or equipment list data and inserted into the drawing. You can also select one of the methods below to insert an alternative symbol.

Click Insert on the Panel terminals, Panel components, or Schematic equipment list in dialog boxes.

#### **Icon Menu**

Displays the icon menu from which you can select the schematic component to insert. This is different than the schematic symbols in the list and should not be considered another way to select the same components.

#### **Copy Component**

Copies a "just like" component and annotates it with the panel data.

## **Insert from panel lists**

Let your project set of panel layout drawings help drive the schematic wiring diagrams. AutoCAD Electrical finds a match for the panel footprint in the [schematic lookup database](#) on page 780 to determine the correct schematic symbol to insert.

If a copy of the panel data is not in memory, then AutoCAD Electrical prompts you to select which panel data you want to extract. Make your selection in the dialog box and click OK. A list of all panel footprints is extracted. Select from the panel list and place the schematic symbol on the wiring diagram.

## Insert components or terminals from panel lists

After the schematic component is selected and inserted in the drawing, all panel-related information is copied to the schematic. Use the Insert/Edit Component dialog box to make any additional changes to the new schematic component.

- 1 Click Schematic tab ► Insert Components panel ► Insert Components



drop-down ► Panel List.

or to insert terminals

Click Schematic tab ► Insert Components panel ► Insert Components drop-down ► Terminal (Panel List).

- 2 Specify whether to extract the panel component/terminal list for the active drawing or the active project.
- 3 Specify any installation or location codes to extract.
- 4 Click OK.
- 5 If you are extracting for the entire project, select which drawing files to process, and click OK.
- 6 On the Panel Components (or Panel Terminals) dialog box, select from the list of panel components/terminals to insert the schematic symbol on the schematic drawing.  
To modify the pick list so you can easily find the component or terminal to select, click Sort List, Display, or Mark Existing.
- 7 Click Insert.
- 8 On the Insert dialog box, select which block name to insert from the list.  
If you want to insert an alternative block that is not in the list, click Icon Menu to select a component from the icon menu or click Copy Component to insert a component 'just like' another existing component.
- 9 Click OK.
- 10 Select the insertion point on the drawing.
- 11 Make any changes to the inserted component in the Insert/Edit Component dialog box and click OK.

## Panel layout list -> schematic components insert

This tool lists panel components extracted from your panel drawing, finds the appropriate schematic symbol, and inserts the schematic components at your pick point.

 **Ribbon:** Schematic tab ► Insert Components panel ► Insert Components



 **Toolbar:** Insert Component

 **Menu:** Components ► Insert Component (Panel List)

 **Command entry:** AECOMPONENTPNL

<b>Extract component list for</b>	Specifies to export the data for the active drawing or the entire active project.
<b>Save list to external file</b>	Creates a comma-delimited file of the panel component data. The extracted file name is the same as the project by default (project_name.WD4). You can display this data in spreadsheet format (open it in comma-delimited "CSV" format), edit, and then save.
<b>Browse</b>	Uses a previous project's panel component list to create a spreadsheet listing. After the initial extraction, a list of panel components displays for selection.
<b>Installation Codes to extract</b>	Extracts only the information for components with specific installation values. Once you pick Named Installations, you can type the installation code in the box or click List: Drawing or List: Project to select from a list of used installation codes.
<b>Location Codes to extract</b>	Extracts only the information for components with specific location values. Once you pick Named Location, you can type the location code in the box or click List: Drawing or List: Project to select from a list of used location codes.

## Panel components

This presents a list of all panel components extracted from the project's panel layout drawings. As you pick an item from the pick list, the appropriate

schematic symbol is found and inserted in the drawing at your pick point. After the selection of the schematic component and the annotation of the device tag, all panel-related information such as descriptions, installation, and location codes are copied to the schematic.

You can select to insert a single schematic component or multiple components from the panel list.

 **Ribbon:** Schematic tab ► Insert Components panel ► Insert Components

drop-down ► Panel List.

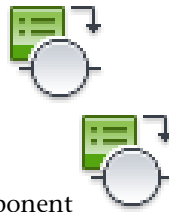

 **Toolbar:** Insert Component

 **Menu:** Components ► Insert Component (Panel List)

 **Command entry:** AECOMPONENTPNL

Select Project and click OK. Select the files to process and click OK.

### Sort List

Sorts the list of panel components. You can specify four sorts to perform on the list.

### Reload

Reopens the Panel Layout List ► Schematic Components Insert dialog box so you can re-extract data or select a saved external file to use.

### Mark Existing

Matches panel components extracted from the project database with schematic components previously placed into the drawing and marks any existing components. An "x" displays in left-hand column for any listed panel component tag that already has its schematic component inserted on the drawing and there is an exact match on catalog and manufacturer values between the two. An "o" displays if the tags match but there is mismatch on catalog and manufacturer values between the two.

### Display

Specifies to show all extracted panel data or hide the panel data that has a matching schematic component.

### **Catalog Check**

Performs a Bill of Material check and displays the result. This is enabled if the selected panel item contains catalog data.

### **TAG Options**

Specifies whether to use the panel tag as is, or recalculate the schematic tag based on the tagging settings of the drawing. When a component that doesn't have a tag is selected from the list, this switch is automatically set to Use auto-generated schematic TAG.

#### **Use auto-generated schematic TAG**

Modifies the schematic component tag based on the drawing settings. If a new tag is generated when inserting the schematic component, the source panel footprint is updated with the generated tag. The active drawing is automatically updated, while updates on other drawings are maintained inside of the update task file (project\_name.upd) for later modification of the panel drawings to match the new schematic component tag.

#### **Use panel footprint TAG**

Maintains the tag as defined in the panel component listing and sets the tag to fixed in the schematic.

### **Scale**

Specifies the block insert scale. (1.0 = full) The drawing scale is used as the default.

### **Vertical**

Changes the default drawing orientation.

### **Insert**

Finds and inserts a schematic component for the highlighted panel component. The query of the schematic\_lookup.mdb file returns one or more block names based on data that appears in the pick list. The results are displayed in the Insert dialog box along with a short description of each choice.

### **Pick File**

Picks a file for the insert. Select an existing AutoCAD Electrical extracted panel component list file or extract a fresh copy of panel component data from the current project's database.

## Panel terminal list -> schematic terminals insert

This report provides error checking between the schematics and the panel layout drawings. The program looks at the selected drawings, both schematic and panel, looking for a match. For each panel component, the routine tries to find a matching schematic component based on tag, location, and installation information. If a match is found, then it compares catalog information looking for any discrepancies.

 **Ribbon:** Schematic tab ► Insert Components panel ► Insert Components

drop-down ► Terminal (Panel List).

 **Toolbar:** Insert Component

 **Menu:** Components ► Insert Terminal (Panel List)

 **Command entry:** AETERMINALPNL

<b>Extract terminal list for</b>	Specifies to export the data for the active drawing or multiple drawings in the active project.
<b>Save list to external file</b>	Creates a comma-delimited file of the panel component data. The extracted file name is the same as the project by default (project_name.WD4). You can display this data in spreadsheet format (open it in comma-delimited "CSV" format), edit, and then save.
<b>Browse</b>	Uses a previous project's terminal list to create a spreadsheet listing. After the initial extraction, a list of terminals displays for selection.
<b>Installation Codes to extract</b>	Extracts only the information for panel terminals with specific installation values. Once you pick Named Installation, you can type the installation code in the box or click List: Drawing or List: Project to select from a list of used installation codes.
<b>Location Codes to extract</b>	Extracts only the information for panel terminals with specific location values. Once you pick Named Location, you can type the location code in the box or click List: Drawing or List: Project to select from a list of used location codes.

## Panel terminals

This presents a list of all panel terminals extracted from the project's panel layout drawings. As you pick an item from the pick list, the appropriate schematic terminal is found and inserted in the drawing at your pick point. After the selection of the schematic terminal and the annotation of the device tag, all panel-related information such as descriptions, installation, and location codes are copied to the schematic.

You can select to insert a single terminal block or multiple terminal blocks from the panel list.

 **Ribbon:** Schematic tab ► Insert Components panel ► Insert Components

drop-down ► Terminal (Panel List).

 **Toolbar:** Insert Component

 **Menu:** Components ► Insert Terminal (Panel List)

 **Command entry:** AETERMINALPNL

Select Project and click OK. Select the files to process and click OK.

<b>Sort List</b>	Sorts the list of panel terminals. You can specify four sorts to perform on the list.
<b>Reload</b>	Reopens the Panel Terminal List ► Schematic Terminals Insert dialog box so you can re-extract data or select a saved external file to use.
<b>Mark Existing</b>	Matches schematic components extracted from the project database with panel terminal components and marks any existing components. An "x" displays in left-hand column for any listed panel component tag that already has its schematic inserted on the drawing and there is an exact match on catalog and manufacturer values between the two. An "o" displays if the tags match but there is mismatch on catalog and manufacturer values between the two.
<b>Display</b>	Specifies to show all extracted panel data or hide the panel data that has a matching schematic component.
<b>Catalog Check</b>	Performs a Bill of Material check and displays the result. This is enabled if the selected panel terminal contains catalog data.

<b>Last symbol used</b>	Displays the last symbol selected through the insert process. You can clear the selection and go back through the insert process to select the schematic terminal symbol or you can automatically insert the last symbol used by not making any changes.
<b>Scale</b>	Specifies the block insert scale. (1.0 = full)
<b>Rotate</b>	Changes the default drawing orientation.
<b>Insert</b>	Finds and inserts a schematic terminal for the highlighted panel terminal. A query of the schematic_lookup.mdb file returns one or more block names based on data that appears in the pick list. The results are displayed in the Insert dialog box along with a short description of each choice.
<b>Pick File</b>	Specifies to pick a file for the insert. Select an existing AutoCAD Electrical extracted panel terminal list file or extract a fresh copy of panel component data from the current project's database.

## Manipulate Components

### Manipulate components

You can manipulate components by moving, stretching, splitting, aligning, or deleting them.

#### Delete components

The Delete Component command lets you remove the selected component. The broken wires are repaired and any resulting instances of multiple wire numbers now assigned to a single wire network are reconciled. In the case of a child contact, AutoCAD Electrical looks for its parent on the current drawing and removes the deleted contact from the parent's cross-reference annotation (if the parent is on some other drawing then a separate run of the Cross-reference command may be required on the drawing set). If you erase a parent schematic component you will have the option to search for related child components, surf to them, and optionally delete them.



### Scoot components/wire segments

The Scoot command lets you quickly reposition components and wire segments. Select directly on a component to slide just that component along its connected wire(s). Wires remain connected to components and existing wire numbers re-center. The component's movement will be constrained along the wire segment. To scoot a ladder rung, including all its components and wire numbers, select directly on any wire segment that makes up the rung. Scoot works on wire numbers, components, terminals, PLC I\O modules, jogs in dashed link lines, signal arrows, wires, and wires with wire-crossing loops.

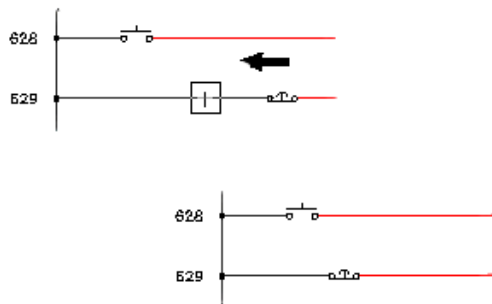

---

**NOTE** Components constrained by connected wiring at right angles will not scoot.

---

### Align components/wire numbers

The Align Components command aligns the selected component with a master component that you select. All connected wires will be adjusted, and wire numbers re-centered if necessary. You can align vertically or horizontally by flipping the command with a V or H character and a [space] entered on the command line.

---

**NOTE** The Align Component command can be used on panel layout symbols.

---

### Move components

The Move Component command removes the selected component from its current location/wire connection and inserts it into a new position. AutoCAD Electrical uses a rotated version of the symbol, if necessary, as it breaks and reconnects any underlying wires. AutoCAD Electrical attempts to repair the broken wires and reconcile multiple wire numbers left over in the component's vacated position. If you use this command and select on a panel footprint, AutoCAD Electrical issues the normal AutoCAD Move command.

### Move component attributes

The Move/Show Attributes command removes the selected attribute from its current location and inserts it into a new position. If you accidentally pick on the block's graphics instead of an attribute, this move command will kick into the attribute Display/Edit mode instead.

### Stretch PLC modules

The Stretch PLC Module command is a very handy feature, especially for PLC modules. Let's say you have a PLC module and you need to add a couple components in parallel on a particular rung and you did not leave enough room between the I/O points. What do you do? You could erase everything and rebuild the module and then reinsert the components, redo the wiring, etc. or you could use the Stretch PLC Module command.

---

**NOTE** The block name itself is changed to make it unique.

---

### Split PLC modules

The Split PLC Module command is especially handy for splitting PLC modules once they have been built or inserted. Maybe you need to move the last few I/O terminal points to another ladder to make room for some other devices.

### Delete components

Deletes the components you select, and corrects resulting wire gaps.

For a child contact, Delete Component updates the cross-reference on the parent. If you erase a parent schematic component, you have the option to search for related components and delete them.

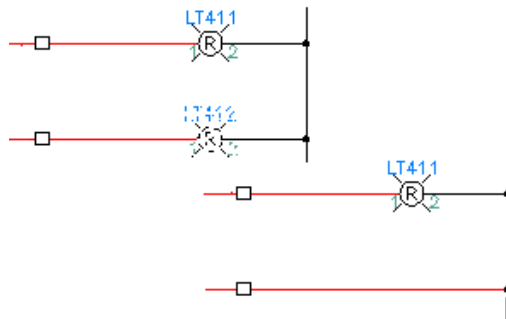

- 1 Click Schematic tab ► Edit Components panel ► Delete Component.



- 2 Select the components to delete.
- 3 Press Enter.

---

**NOTE** If you erase a parent schematic component, you have the option to search for related child components, surf to them, and delete them.

---

### Scoot components/wire segments

Scoots wire numbers, components, wire segments, link lines, PLC text, and signal arrows.

Scoot quickly repositions components and wire segments. Click a component to slide just that component along its connected wires. Wires remain connected and existing wire numbers center themselves. To scoot a ladder rung, including all its components and wire numbers, click any wire segment.

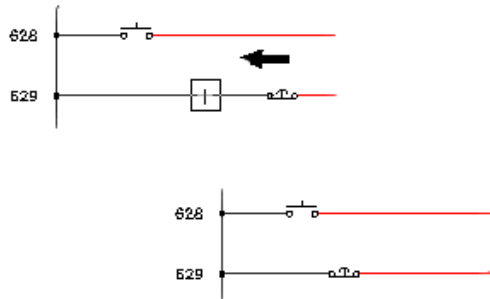

- 1 Click Schematic tab ► Edit Components panel ► Modify Components



drop-down ► Scoot .

- 2 Select the component to scoot along its connected wires or select the wire segment to scoot the entire wire, including components, along the bus. A rectangle indicates the selected items.
- 3 Move your cursor to the appropriate position and click. The items scoot and reconnect.

---

**NOTE** You can run the Auto-Retag operation on the components if they move to a new line reference, or update the child cross-references only.

---

## Align components/wire numbers

Aligns selected components or wire numbers with the selected master.

Select the components individually or with a window. Align adjusts all connected wires, and recenters wire numbers. Align vertically or horizontally by flipping the command with a V or H character followed by a [space] entered on the command line.

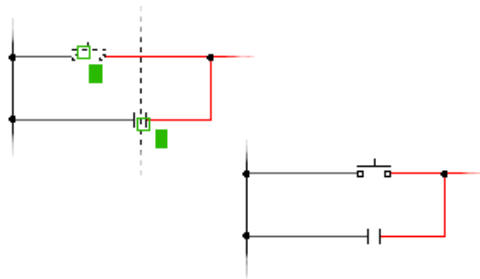

- 1 Click Schematic tab ► Edit Components panel ► Modify Components

drop-down ► Align.



- 2 Select the master component to align with. A temporary line appears showing the alignment position.
- 3 Select the components to move into alignment with the selected master component. You can select the components individually or by windowing. All connected wires are adjusted, and wire numbers recentered if necessary. You can align vertically or horizontally by flipping the command with a V or H character and a [space] entered on the command line.

## Move components

Moves a component you select in a drawing to a point you specify, and includes automatic update of the component tag.

A Move Component operation breaks and reconnects any underlying wires, and inserts a rotated version of the symbol, if necessary. It repairs broken wires

and removes unnecessary wire numbers left in the position the component vacated.

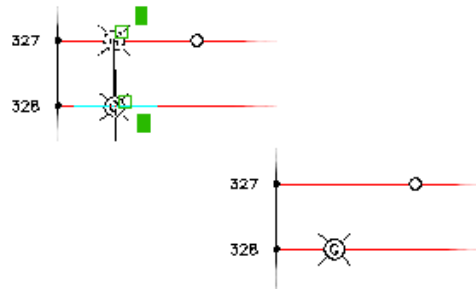

- 1 Click Schematic tab ► Edit Components panel ► Modify Components



drop-down ► Move Component.

- 2 Select the component to move.
- 3 Select the insertion point for the move. The component automatically moves to the selected position.

## Stretch PLC modules

Stretches or compresses a windowed portion of a PLC module (or any block insert).

Maintains all the original block information, including attributes.

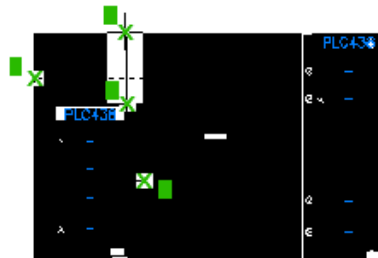

- 1 Click Schematic tab ► Edit Components panel ► Modify Components



drop-down ► Stretch PLC Module.

- 2 Select the blocks to stretch using a crossing window or crossing polygon window.
- 3 Press Enter.
- 4 Select your base and second point of displacement.  
The exploded blocks stretch and are then rebuilt (maintaining all the original block information, including attributes).

## Split PLC modules

- 1 Click Schematic tab ► Edit Components panel ► Modify Components



drop-down ► Split PLC Module.

- 2 Select the block to split.
- 3 Select the split point or enter “M” to select the objects for the new child component using a crossing window or crossing polygon.  
Keep windowing until all objects are selected. To cancel the selection of any object, press U and select as usual.
- 4 Define the origin point for the new block. You can enter the coordinates or click Pick Point and select the origin point on the drawing.
- 5 Set the break type: no lines, straight lines, jagged lines, or draw it.
- 6 (Optional) Select to reposition the child block to move it as part of this command.
- 7 Click OK.
- 8 To reposition the child block, select a point on the screen to place the block.

## Split block

Use this tool to split blocks or parametric connectors into 2 separate block definitions (for example, parent and a child or a child and another child).

## Split PLC Module

 **Ribbon:** Schematic tab ► Edit Components panel ► Modify Components



drop-down ► Split PLC Module.



 **Toolbar:** Scoot

 **Menu:** Components ► Component Miscellaneous ► Split PLC Module

 **Command entry:** AESPLITPLC

Select the block to split and specify the split point.

You specify:

- Origin point for the new block
- Break type
- Layer for the child block
- Whether to reposition the child block

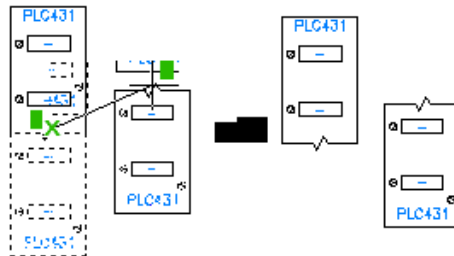

## Split Connector

 **Ribbon:** Schematic tab ► Edit Components panel ► Modify Connectors



drop-down ► Split Connector.



 **Toolbar:** Insert Connector

 **Menu:** Components ► Insert Connector ► Split Connector  
 **Command entry:** AESPLIT

Select the connector to split and specify the split point.

You specify the following:

- Origin point for the new block
- Break type
- Layer for the child block
- Whether to reposition the child block

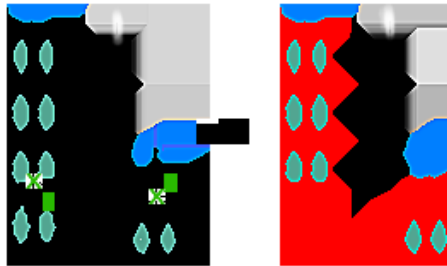

**Child Base Point**

Specifies the origin point for the new block. The default is in-line with the first set of pins on the split-off piece. If you do not want to accept the default, enter the coordinates or click Pick Point and select the origin point on the drawing.

**Break Type**

Specifies the break type: no lines, straight lines, jagged lines, or draw it. The default is set to jagged lines. Click Draw to manually draw the break type on the drawing.

**Layer**

Specifies the layer for the child block. You can accept the default or click List to select the layer from a list of existing layers.

**Reposition Child Block**

Specifies to reposition the child block to move it as part of this command.



## Reverse/flip components

Use this tool to reverse or flip selected component graphics and its associated attributes.

---

**NOTE** This tool only operates on a component with 2-wire connections (for example, limit switch contact symbol).

---

- 1 Click Schematic tab ► Edit Components panel ► Modify Components

drop-down ► Reverse/Flip Component.



- 2 Select whether to reverse or flip the component.

---

**NOTE** Components are reversed perpendicular to the axis formed by the two wire connections or flipped along the axis of the wire connection.

---

- 3 (Optional) Select to reverse or flip the graphics only.

## Reverse/flip component

Reverses or flips the orientation of a component.

 **Ribbon:** Schematic tab ► Edit Components panel ► Modify Components

drop-down ► Reverse/Flip Component.



 **Toolbar:** Scoot



 **Menu:** Components ► Reverse/Flip Component

 **Command entry:** AEFLIP

Available when a component has only two wire connections. Specify to reverse or flip only the graphics, or include component attributes.



<b>Reverse</b>	Reverses the component graphics and the attributes perpendicular to the axis formed by the two wire connections.
<b>Flip</b>	Flips the component graphics and the attributes along the axis of the wire connection (for example, from top-side of the wire to the bottom and vice versa).
<b>Graphics only</b>	Specifies to reverse or flip only the graphics; component attributes are not modified.

## Annotate ratings attributes

### Annotate ratings attributes

- 1 Click Schematic tab ► Edit Components panel ► Edit Components



drop-down ► Edit.

- 2 Click the Show All Ratings button in the Insert/Edit Components dialog box.  
The View/Edit Rating Value dialog box displays, letting you enter values for each ratings attribute.
- 3 Click the Defaults button next to the edit box to display the list of default values.
- 4 Select a line from the file to map its values to the available rating attributes.

Notice that a single line may carry multiple values with each value separated by a "|" character. Any text that follows a semi-colon is considered a comment and will be ignored.

- 5 Choose whether to select a different file or add a new entry to the ratings defaults file.
- 6 Click OK to finish the operation.

You may create multiple .WDR files. AutoCAD Electrical will look for a generic defaults file called WD\_RATINGS.WDR stored in the AutoCAD Electrical support directory. You may also create a project-specific file with the same name and path as the project with the .WDR extension. You may also have Family-specific files named for the Family code of the component with the .WDR extension. For example, if the component has the family code "PB" for push buttons and a file called PB.WDR exists, it will display when you select the "Family" button.

---

**NOTE** If the Show All Ratings button is disabled, the component you are editing does not have a rating attribute.

---

## Ratings defaults

AutoCAD Electrical allows up to 12 Ratings attributes on a component. To help you annotate these attributes AutoCAD Electrical lets you pick from a list of defaults. To take advantage of this feature you need to create/modify a text file with a .WDR extension. This file is a simple text file and can be edited with any editor such as WordPad.

 **Ribbon:** Schematic tab ► Edit Components panel ► Edit Components

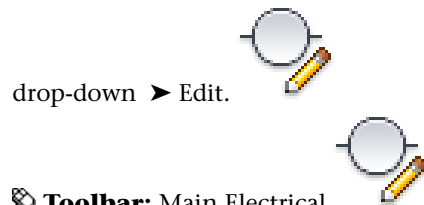

 **Toolbar:** Main Electrical

 **Menu:** Components ► Edit Component

 **Command entry:** AEEDITCOMPONENT

Click the Show All Ratings button, and then click Defaults.

**Ratings panel** Displays the values for the rating attribute.

**Pick File** Selects a different file and description list.

<b>Project</b>	Displays a project .WDD file (if it is not already displayed).
<b>Family</b>	Displays family-specific files named for the Family code of the component. For example, if the component has the family code "PB" for push buttons and a file called PB.WDD exists, it will display when you select the Family button.
<b>Generic</b>	Displays a generic file (WD_DESC.WDD) if it is not already displayed.
<b>Add/Edit</b>	Adds a new entry to the rating defaults file. Enter a value in the dialog box or click Edit File to edit the file using WordPad.

## Swap contact states

### Swap contact states

Switches a selected component between the Normally Open and Normally Closed contact states.

The program looks at the selected contact, reads its block name, and checks the fifth character for either 1 or 2. It looks for a matching block name with the opposite 1 or 2, and swaps this block for the existing block.

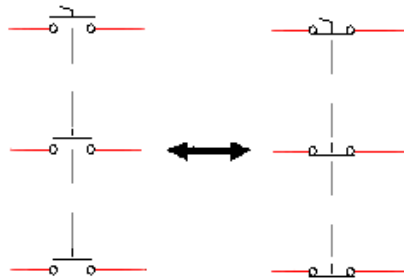

- 1 Click Schematic tab ► Edit Components panel ► Toggle NO/NC.



- 2 Select the component to toggle.

- 3 (Optional) Type Ctrl + Z to undo the contact swap if you selected the wrong component.  
Existing attribute text is preserved on the flipped contact. If the maximum contact counts are carried by the parent symbol, the maximum counts are checked so that they are not exceeded by the flip.

## Component Cross-References

### Cross-Referencing

Cross-referencing is based on collecting and annotating groups of components that carry the same TAG text string value (for example, 101CR). Components do not have to be of the same family to be cross-referenced, but they must have the same TAG1/TAG2/TAG\_\*/TAG attribute values.

Cross-reference data is annotated on to attributes XREFNO and XREFNC for N.O and N.C. references respectively. Alternately, if attribute XREF is present, both N.O. and N.C. references are combined into a single cross-reference text string.

The AutoCAD Electrical Component Cross-reference tool creates two text reports in the process of annotating components with cross-reference information. The Cross-reference report gives a listing of each component and quantity and locations of child contacts. The Exception/Error report lists the exceptions AutoCAD Electrical found as it processed the drawing or drawing set. Exceptions include child contact with no parent and parent relay coil with no child contacts found.

### Cross-Reference

- 1 Click Schematic tab ► Edit Components panel ► Modify Component



Cross-Reference drop-down ► Component Cross-Reference.

- 2 Select to process:
  - **Project** - select from a list of project drawings to process.
  - **Active drawing (all)** - process all components on the active drawing.
  - **Active drawing (pick)** - select components to process.

- 3 Click OK.
- 4 If Active drawing (all) is not selected, select the components or drawings to process.  
The components are cross-referenced and the Cross-Reference Report or Error/Exception Report dialog box displays.
- 5 Select from the options:
  - **Cross-reference** - display the Cross-Reference Report which gives a listing of each component and quantity and locations of child contacts.
  - **Exception** - display the Error/Exception Report which lists the exceptions found. Exceptions include child contacts with no parent and parent relay coils with no child contacts.
  - **Surf** - surf to components listed in the Error/Exception report.
  - **Print** - print the displayed report.
- 6 Click Close.

## Component cross-reference

Adds or updates cross-reference text on related parent and child components.

 **Ribbon:** Schematic tab ► Edit Components panel ► Modify Component

Cross-Reference drop-down ► Component Cross-Reference.

 **Toolbar:** Main Electrical 2

 **Menu:** Components ► Cross-Reference ► Component Cross-Reference

 **Command entry:** AEXREF

The drawing properties define the cross-referencing format. Component Cross-reference creates both a listing of each component with the quantity and locations of child contacts, and an exception report.

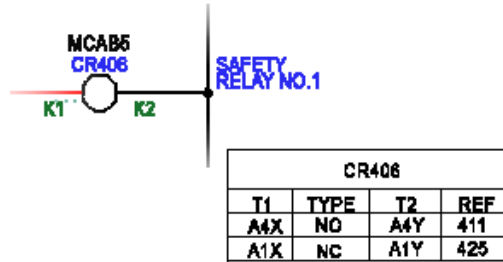

Cross-referencing is based upon collecting and annotating groups of components that carry the same TAG text string value (such as "101CR"). Components do not have to be of the same family to be cross-referenced; they must have the same TAG1/TAG2/TAG\_\*/TAG attribute values.

Cross-reference data is annotated on to attributes "XREFNO" and "XREFNC" for N.O and N.C. references respectively. Alternately, if attribute XREF is present, both N.O. and N.C. references are combined into a single cross-reference text string.

<b>Run Cross-Reference on</b>	Specifies to run the report on selected components, the current drawing, or the entire project.
<b>Cross-reference</b>	Displays the last Cross-Reference report.
<b>Exception</b>	Displays the last Exception/Error report.

### Using other dialog boxes to set cross-reference options

- The cross-reference format is set up on the Drawing Properties ► Cross-Reference dialog box. It is on a per-drawing basis and can include sheet and drawing ID, line or grid-reference location, and fixed punctuation.
- A project-wide option to fill unused contact references with a user-defined text string is available using the [Project Manager](#) on page 215 tool. Right-click the project name and select Properties. In the Project Properties ► Cross-References dialog box, Component Cross-Reference Display section, select Text Format and click Setup.
- Real-time cross-reference update can be turned on or off on the Project Properties ► Cross-References dialog box.

## Surfing on Cross-Reference Exception reports

- 1 Click Schematic tab ► Edit Components panel ► Modify Component



Cross-Reference drop-down ► Component Cross-Reference.

- 2 Select to process: the project, active drawing, or selected components.
  - **Project** - select from a list of project drawings to process.
  - **Active drawing (all)** - process all components on the active drawing.
  - **Active drawing (pick)** - select components to process.
- 3 Click OK.
- 4 If the Active drawing (all) option is not selected, select the components or drawings to process.

The components are cross-referenced and the Cross-Reference Report or Error/Exception Report dialog box displays.
- 5 Select Exception to display the Error/Exception Report.
- 6 Select Surf.

AutoCAD Electrical changes to surfer mode.
- 7 Double-click any listed error/exception entry in the Surf dialog box.

AutoCAD Electrical surfs to the appropriate drawing and zooms up on the offending contact.
- 8 Click Edit to correct the error, and then surf to the next one.

## Change cross-reference visibility

This tool changes the visibility of the cross-reference XREF attribute. In most cases, the cross-referencing should be visible but there are times when you may not want the cross-referencing displayed on parent symbols.

- 1 Click Schematic tab ► Edit Components panel ► Modify Component



Cross-Reference drop-down ► Hide/Unhide Cross-Referencing.

- 2 Select the objects whose cross-referencing you want to hide or display.

Single selection, window selection, or multiple selection is allowed.



- 3 Right-click to end the selection and apply the command.

## Exclude contacts when cross-referencing

You can exclude the contact from being included in any AutoCAD Electrical cross-reference text annotation.

- 1 Enter ATTEDIT at the command line.
- 2 Select the contact that you want to exclude from cross-referencing.
- 3 Change the CONTACT attribute value to "NULL".
- 4 Click OK.

---

**NOTE** Run the Cross-reference command to update the cross-referencing on the parent symbol.

---

## Check coil/contact count

Using the [Cross-Reference Check](#) on page 813 tool, AutoCAD Electrical first extracts a complete list of components from the project drawing set. Then it prompts you to select a component to check. AutoCAD Electrical reads the tag of the component, finds all associated child components, and lists them in a dialog box. It also displays the assigned catalog number of the parent (if one exists). You can do a catalog check to see if the description of the item indicates that the quantity of contacts can be accommodated.

### Component reference listing

The Cross-Reference Check tool displays all associated and parent components to the selected component.

 **Ribbon:** Schematic tab ► Edit Components panel ► Modify Component

Cross-Reference drop-down ► Cross-Reference Check.

 **Toolbar:** Cross-Reference

 **Menu:** Components ► Cross-Reference ► Cross-Reference Check

 **Command entry:** AEXREFCHECK

A complete list of components is extracted from the project drawing set. The tag of the component is read, then all associated components are found and listed in the dialog box. A bill of material check can be performed to see if the description of the item indicates that the quantity of contacts can be accommodated.

### References

- **N.O. references:** Lists the number of normally open contacts assigned to the selected component.
- **N.C. references:** Lists the number of normally closed contacts assigned to the selected component.
- **Other references:** Lists the number of child devices that are neither NO or NC contacts. They can include pins of a connector, form C contacts, or general devices that are being referenced.
- **Reference listing:** Lists the type, number, location, installation, and description text for the reference.

### Parent Information

- **Manufacturer code:** Lists the associated manufacturing code of the parent (if one exists).
- **Catalog number:** Lists the associated catalog number of the parent (if one exists).
- **Assembly code:** Lists the associated assembly code of the parent (if one exists).
- **Catalog Check:** Creates a BOM description for the selected component using the catalog number of the parent component. Comparing the description (2 available) with the contact count (3 required) reveals a needed adjustment.
- **Catalog lookup:** Opens the parts catalog to look up component-specific catalog information.

## Overview of cross-reference settings

Cross-reference settings are supported at the project, drawing, and component level.

### Project Cross-Reference Settings

Settings are maintained inside of the project definition file (.wdp). Once settings are created for the project, AutoCAD Electrical applies those settings to new, existing, and copied drawings inside of the project. Ultimately, cross-reference settings are written to the WD\_M block of the drawing file to use during normal operations.

### Drawing Cross-Reference Settings

Settings are maintained on the WD\_M block of the drawing. When the cross-reference command is run, AutoCAD Electrical uses the drawing settings to determine the cross-reference types. During program runtime, the cross-reference command looks at the WD\_M block as the definition for all referencing on the drawing.

### Component Cross-Reference Settings

Settings are maintained at the component to override the drawing's WD\_M block settings of the drawing. During program runtime, the cross-reference command first looks to the component definition before the WD\_M block as the definition for referencing the component on the drawing.

During normal operation of cross-referencing commands, AutoCAD Electrical looks to the component for its settings information before using the drawing settings. If the component has settings defined, they are used. If there are both component and drawing cross-reference settings on the same drawing, the component settings are used where applied and the drawing settings are used for the rest of the components.

### Set cross-referencing display

Cross-reference settings are supported at the project, drawing, and component level. Changes you make to the settings are automatically updated in real time.

---

**TIP** To set display settings for a specific component that are different from the drawing, use the Copy/Add Component Override tool.

---

- 1 Click Project tab ► Project Tools panel ► Manager. 
- 2 In the Project Manager, right-click the project or drawing name, and select Properties.

---

**NOTE** Selecting the project applies changes to the project definition file and not the drawing. Apply the settings to drawings to see display changes.

---

- 3 Click the Cross-references tab. In the Component Cross-reference Display section, select Text, Graphical, or Table Format and click Setup.
  - **Text Format:** Displays cross-referencing as text with any user-defined string as a separator between references on the same attribute.
  - **Graphical Format:** Displays cross-referencing using the AutoCAD Electrical graphical font or using contact mapping edit boxes while displaying each reference on a new line.
  - **Table Format:** Displays cross-referencing in a table object so you can define the columns to display.
- 4 Specify the format for the cross-reference display.

The Preview box shows an image that shows an example of the cross-referencing format being defined.
- 5 Select the display options.

---

**TIP** See the Reference topics for each cross-reference display format to learn about the various display options.

---

- 6 If you selected to use the Table Format style, specify the table style and table title. Select a table style from the list. The list initially displays table styles from the active drawing and from the table styles drawing. Click Browse to select a drawing with the desired table style. Once selected, the table style is applied to the Table Styles drawing.

To set the table title:

  - Select the allowable replaceable parameter entry from the selection list
  - Enter the replaceable parameter
  - Enter text

7 Click OK.

If you selected to use the Table Format style, the table location is based on the cross reference attribute position. You can move the table to any location on the drawing and the table remains in the new position for that symbol.

## Cross-reference component override

You can define components to have different cross-referencing styles. The settings specified using this tool override the drawing properties. Component overrides are copied when the component is copied; similarly they are applied to multiple inserts of the same component.

 **Ribbon:** Schematic tab ► Edit Components panel ► Modify Component



Cross-Reference drop-down ► Copy/Add Component Override.



 **Toolbar:** Cross-Reference

 **Menu:** Components ► Cross-Reference ► Copy/Add Component Override

 **Command entry:** AECOPYOVERRIDE

---

**NOTE** You can also access this when you use [Insert Component](#) on page 742. Select the component type to insert and specify the insertion point on the drawing. In the Insert/Edit Component dialog box, Cross-Reference section, select Component override and click Setup.

---

Select the component with settings to copy or override.

### Cross-Reference Format

Defines the cross-reference annotation format. One replaceable parameter, %N, must always be part of the cross-reference format string. A typical format string might be just the %N parameter. Use the upper section for on-drawing references and the bottom section for off-drawing references. You can use the same format for both.

---

**NOTE** If your format includes the sheet number %S parameter or the drawing number %D parameter, enter the values in the edit boxes in Sheet Values section of the Drawing Properties ► Drawing Settings dialog box.

---

### Component Cross-Reference Display

There are different styles of cross referencing AutoCAD Electrical supports:

- **Text Format:** Displays cross-referencing as text with any user-defined string as a separator between references on the same attribute.
- **Graphical Format:** Displays cross-referencing using the AutoCAD Electrical graphical font or contact mapping edit boxes while displaying each reference on a new line.
- **Table Format:** Displays cross-referencing in a table object, that automatically gets updated in real time, while allowing you to define the columns to display.

Click Setup to display a dialog box for setting the display defaults for each component cross-reference display format.

## Remove component overrides

You can apply overrides to a component so its settings override those of the drawing or project. Use this tool to remove the component overrides so the cross-referencing commands use the settings for the drawing or project.

 **Ribbon:** Schematic tab ► Edit Components panel ► Modify Component

Cross-Reference drop-down ► Remove Component Override.

 **Toolbar:** Cross-Reference

 **Menu:** Components ► Cross-Reference ► Remove Component Override

 **Command entry:** AERMOVERRIDE

Select to remove the component overrides on the project, active drawing, or selected components on the drawing.

Project and Active drawing (all) remove overrides on all components on the drawings while Active drawing (pick) removes overrides for selected components only.

## Text cross-reference format setup

This format displays cross-referencing as text with any user-defined string as a separator between references on the same cross-reference attribute.

---

**NOTE** Mtext cross-referencing can still be used on selected components that use text cross-referencing.

---

 **Ribbon:** Project tab ► Project Tools panel ► Manager. 

 **Toolbar:** Main Electrical 2 

 **Menu:** Projects ► Project ► Project Manager

 **Command entry:** AEPROJECT

In the Project Manager, right-click the project or drawing name and select Properties. Click the Cross-References tab. In the component Cross-Reference Display section, select Text Format, and click Setup.

---

**NOTE** You can also access this when you use [Insert Component](#) on page 742. Select the component type to insert and specify the insertion point on the drawing. In the Insert/Edit Component dialog box, Cross-Reference section, select Component override and click Setup. In the Cross-reference component override dialog box, select Text Format, and click Setup.

---

### Format

The Reference Separator edit box allows you to define any string as a separator between references on the same attribute. Spaces are allowed. The default separator is a comma. Use "|" anywhere in the edit box to change the XREF attribute to multi-line text and add a carriage return after each reference. The separator value is applied to the drawing settings in the WD\_M block definition or the component to override the drawing settings.

When there are 2 or more references on the same cross-reference attribute each reference is separated by the specified separator. If you use a comma as the separator the references would look like the following examples:

NO 412,633

NO 20.3,21.3

### **Preview**

Displays an image that shows an example of the cross-referencing format being defined.

### **Options**

<b>Display Unused Children (Contacts)</b>	Displays the child symbols that are not referenced or being used in the project pin list.
<b>Separate Reference</b>	Displays each unused child symbol in its own reference.
<b>Contact Count Totals</b>	Displays the total count of all unused child symbols in a single reference.
<b>Fill Reference With</b>	Specifies what should be displayed in the unused reference position for both Separate and Contact Count options. If left empty, a space appears where the referencing would be displayed. For example if you enter the text "SP" for spares, "SP" displays in the referencing.
<b>Cross-Referencing Sorted by Line Reference</b>	Displays the referencing in the order that the contacts are found in the line reference of the project.
<b>Cross-Referencing Sorted by Pin List Order</b>	Displays the referencing in the order that the Pin List is defined on the parent component. It is sorted regardless if the pins are displayed as part of the referencing.

## **Overview of graphical cross-reference formats**

When you use the graphical cross-reference format style, the preview image changes to show what the cross-reference looks like in the drawing.

### **Graphic Font Format:**

Displays the cross-reference format using the JIC or IEC/GB/JIS graphical font. The setting is applied to the graphical font regardless of the tagging mode



assigned in the project properties. This setting is taken from drawing properties if there are no cross-reference overrides specified on the inserted component.

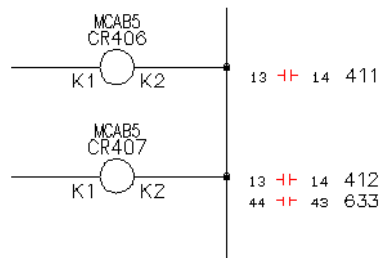

JIC

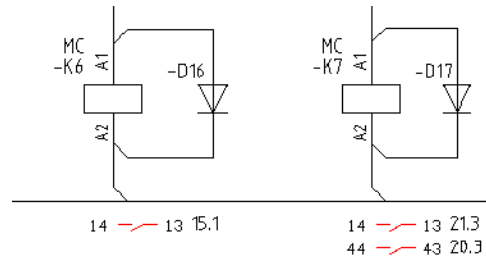

IEC

The following example displays cross-referencing next to the symbol in the graphic font format while the unused children (contacts) are displayed as separate references. The Fill Reference With value is "SP."

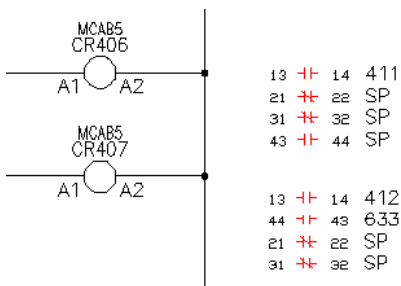

JIC

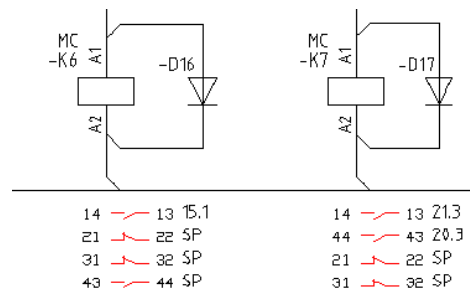

IEC

**Contact Mapping Format:**

Displays the cross-reference format using cross-referencing type values (NO, NC, NONC).

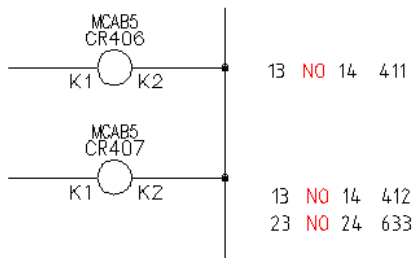

JIC

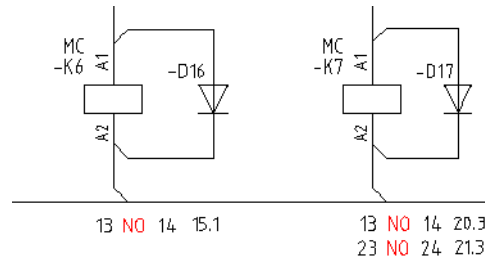



IEC

## Graphical cross-reference format setup

This format displays cross-referencing using the AutoCAD Electrical graphical font or using contact mapping edit boxes while displaying each reference on a new line.

 **Ribbon:** Project tab ► Project Tools panel ► Manager. 

 **Toolbar:** Main Electrical 2 

 **Menu:** Projects ► Project ► Project Manager

 **Command entry:** AEPROJECT

In the Project Manager, right-click the project or drawing name and select Properties. Click the Cross-References tab. In the component Cross-Reference Display section, select Graphical Format, and click Setup.

---

**NOTE** You can also access this when you use [Insert Component](#) on page 742. Select the component type to insert and specify the insertion point on the drawing. In the Insert/Edit Component dialog box, Cross-Reference section, select Component override, and click Setup. In the Cross-reference component override dialog box, select Graphical Format, and click Setup.

---

## Format

In the event where there are 2 or more references for the same component, each reference is entered into a new line.

### Graphic Font

Displays the cross-reference format using a graphical font. Select to use the JIC font or the IEC font. The setting is applied to the graphical font regardless of the tagging mode assigned in the project properties.



The JIC image font style displays the cross-referencing using the JIC style normally open, normally close, and Form C contact types.



The IEC/GB/JIS image font style displays the cross-referencing using the IEC style normally open, normally close, and Form C contact types.

### Contact Mapping

Displays the cross-reference format using cross-referencing type values (NO, NC, NONC). Enter the format into the edit boxes.

## Preview

Displays an image that shows an example of the cross-referencing format being defined.

## Options

### Display Unused Children (Contacts)

Displays the child symbols that are not referenced or being used in the project pin list.

### Separate Reference

Displays each unused child symbol in its own reference. It is dependent on pin list count.

### Contact Count Totals

Displays the total count of all unused child symbols in a single reference.

### Fill Reference With

Specifies what to display in the unused reference position for both Separate and Contact Count options. If left empty, a space appears where the referencing would be displayed. For example if you enter the text "SP" for spares, "SP" displays in the referencing.

## Overview of table cross-reference formats

When you use the table cross-reference format style, the preview image changes to show what the cross-reference looks like in the drawing.

### Graphic Font Format:

Displays the cross-reference format using the JIC or IEC graphical font. The setting is applied to the graphical font regardless of the tagging mode assigned in the project properties.

The following examples display the table cross-referencing using the graphic font format inside the table style. The Fill Reference With value is "SP" for unused children (contacts).

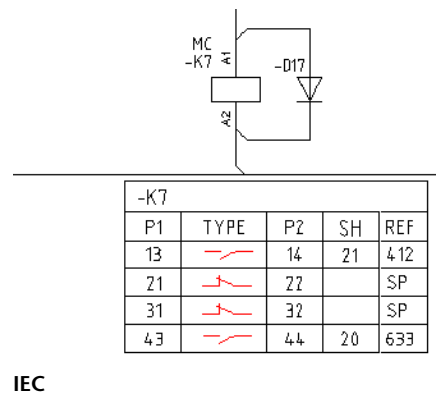
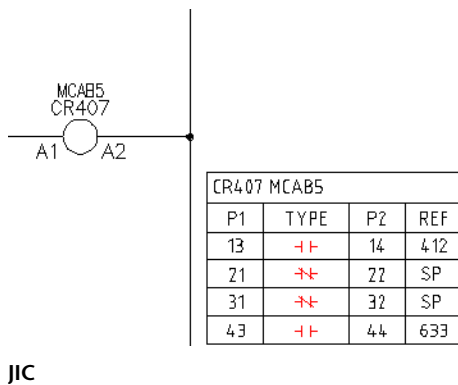

### Contact Mapping Format:

Displays the cross-reference format using cross-referencing type values (NO, NC, NONC).

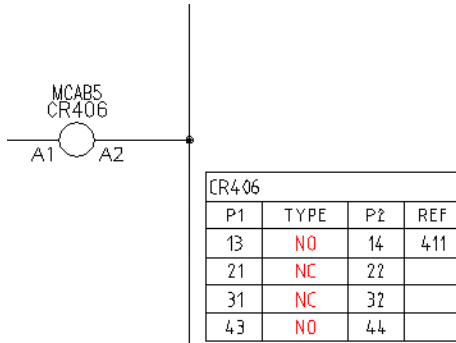

JIC

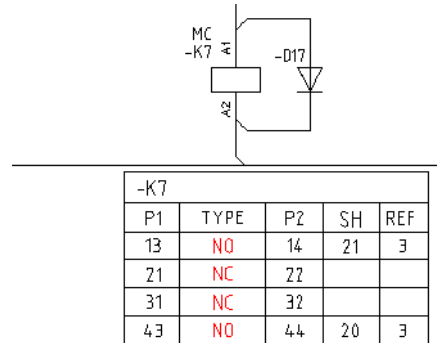

IEC

**Symbol Mapping Format:**

Displays the cross-reference format using an AutoCAD block (.dwg) file to represent the contact type. The \_XREF\_GRAPHICS table in the catalog lookup database defines the symbol mapping. The schematic library folders for the active project are searched for the mapped symbols for insertion.

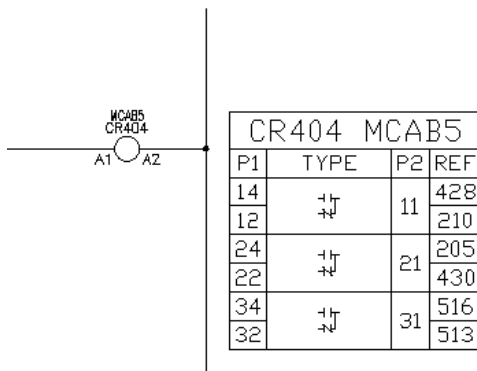

JIC

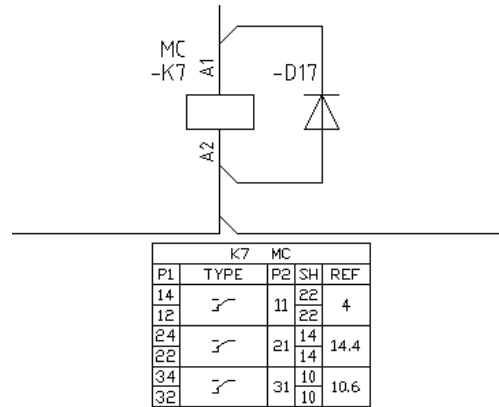

IEC

### Form C contacts and tables

A typical type of contact is a Form C contact type. It is comprised of 2 contacts; 1 open and 1 closed where they share a common terminal pin number. You can choose to insert both of the Form C contacts as two individual symbols, or together as one symbol.

#### Example: Two symbols make up the Form C contact

The common pin is on the right-hand side next to the referencing column and displays in the P2 column of the table.

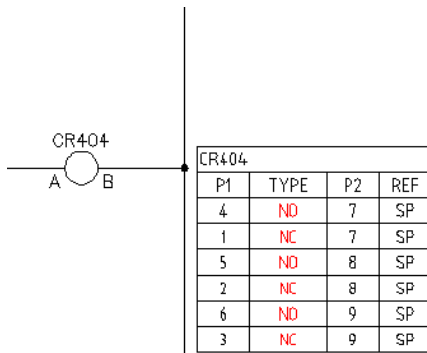

JIC

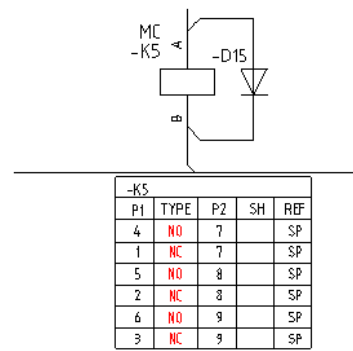

IEC

---

**NOTE** If using the symbol mapping method, a single symbol represents the Form C contact, even if two separate contacts are inserted.

---

#### Example: Single symbol makes up the Form C contact

The common pin is on the right-hand side next to the referencing column and displays in the P2 column of the table.

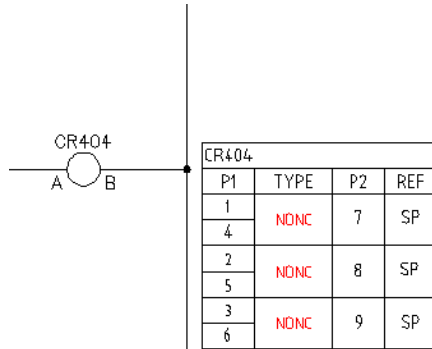

JIC

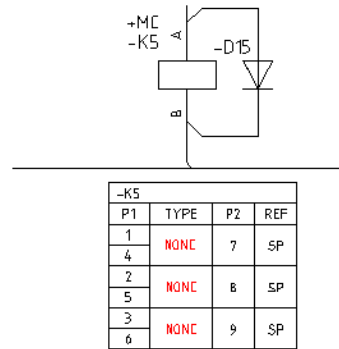

IEC

## Table cross-reference format setup

This format displays cross-referencing in a table object that automatically gets updated in real time, so you can define the columns to display. To display component cross-referencing in a table, select a predefined table style and define the column labels to display.

 **Ribbon:** Project tab ► Project Tools panel ► Manager. 

 **Toolbar:** Main Electrical 2 

 **Menu:** Projects ► Project ► Project Manager

 **Command entry:** AEPROJECT

In the Project Manager, right-click the project or drawing name, and select Properties. Click the Cross-references tab. In the component Cross-reference Display section, select Table Format, and click Setup.

If new contacts are added to the component, the cross-referencing table automatically updates. The table location is based on cross-reference attributes. You can move the table to any location on the drawing and the table remains in the new position.

If you change the table setup once a table has been inserted onto the drawing, run the Component Cross-reference tool to update the table.

---

**NOTE** You can also access this dialog box by selecting Schematic tab ► Insert Components panel ► Icon Menu. Select the component type to insert and specify the insertion point on the drawing. In the Insert/Edit Component dialog box, Cross-reference section, select Component override, and click Setup. In the Cross-reference component override dialog box, select Table Format, and click Setup.

---

## Format

### Graphic Font

Displays the cross-reference format using a graphical font. Select to use the JIC font or the IEC/GB/JIS font. The setting is applied to the graphical font regardless of the tagging mode assigned in the project properties.

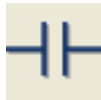

The JIC image font style displays the cross-referencing using the JIC style normally open, normally close, and Form C contact types.



The IEC/GB/JIS image font style displays the cross-referencing using the IEC style normally open, normally close, and Form C contact types.

### Contact Mapping

Displays the cross-reference format using cross-referencing type values (NO, NC, NONC). Enter the format into the edit boxes.

### Symbol Mapping

Displays the cross-reference format using mapped graphic block drawings. Click [Edit](#) on page 830 to modify the mapping settings.

See [Learn about table cross-reference formats](#) on page 820 for examples of the format styles.

## Preview

Displays an image that shows an example of the cross-referencing format being defined.

## Options

### Display Parent (Coil)

Displays the reference information for the parent component inside the cross-reference format.



<b>Display Unused Children (Contacts)</b>	Displays the child symbols that are not referenced or being used in the project pin list.
<b>Separate Reference</b>	Displays each unused child symbol in its own reference.
<b>Contact Count Totals</b>	Displays the total count of all unused child symbols in a single reference.
<b>Fill Reference With</b>	Specifies what to display in the unused reference position for both Separate and Contact Count options. If left empty, a space appears where the referencing would be displayed. For example if you enter the text "SP" for spares, "SP" displays in the referencing.

### Table Style

Table styles are defined within a drawing file to determine the size, shape, style, and font of a table object. There is always a table style on a drawing. The standard table style cannot be deleted. Various style drawing files that determine the drawing-related settings are provided with AutoCAD Electrical. The Table Styles drawing (TableStyle.dwg) defines a series of table objects that are used in the selection process and then copied to the drawing files.

Select a table style from the list. The list initially displays table styles from the active drawing and the TableStyle.dwg. Click Browse to select a drawing with the desired table style. Once selected, the table style can be applied to the Table Styles drawing. If the selected style does not exist on the TableStyle.dwg it is copied to it. When a drawing is referenced the style is then copied from the TableStyle.dwg.

Click Define Columns to open the Cross-reference Table Data Fields to Display dialog box to define the columns for the table cross-referencing.

### Table Title

Controls the replaceable parameters and carriage returns. Select the allowable replaceable parameter entry from the selection list, enter the replaceable parameter to use, or enter text for the table title. Add a carriage return inside of the string by using "\r" anywhere in the Table Title edit box.

---

**NOTE** If the replaceable parameter does not include a value from the drawing, a blank space is displayed in the table title. If the title line is left blank, the table does not show the title row.



---

## Edit cross-reference symbol mapping table

AutoCAD Electrical checks a cross-reference symbol mapping table when the cross-reference table uses the symbol mapping format. This table maps a contact block name to a graphic drawing name. This graphic drawing is inserted as a block in the TYPE column of the cross-reference table for the contact.

### Project Manager

 **Ribbon:** Project tab ► Project Tools panel ► Manager. 

 **Toolbar:** Main Electrical 2 

 **Menu:** Projects ► Project ► Project Manager

 **Command entry:** AEPROJECT

Right-click the project or drawing name, and select Properties. Click the Cross-References tab. In the component Cross-Reference Display section, select Table Format and click Setup. On the Cross-Reference Format Setup dialog box select Symbol Mapping, and click Edit.

### Drawing Properties

 **Ribbon:** Schematic tab ► Other Tools panel ► Drawing Properties

drop-down ► Drawing Properties. 

 **Toolbar:** Main Electrical 2 

 **Menu:** Projects ► Drawing Properties

 **Command entry:** AEPROPERTIES

Click the Cross-References tab. In the component Cross-Reference Display section, select Table Format and click Setup. On the Cross-Reference Format Setup dialog box select Symbol Mapping, and click Edit.

---

**NOTE** You can also access this when you use [Insert Component](#) on page 742. Select the component type to insert and specify the insertion point on the drawing. In the Insert/Edit Component dialog box, Cross-Reference section, select Component override, and click Setup. In the Cross-reference component override dialog box, select Table Format, and click Setup. On the Cross-Reference Format Setup dialog box select Symbol Mapping, and click Edit.

---

This database table is a table within the catalog lookup Access .mdb file. The default file name is default\_cat.mdb, table **\_XREF\_GRAPHICS**, and is populated with a sample of symbol mapping data. Expand this table as needed. Use your copy of Microsoft Access or use this dialog box to add new entries, add entries based on existing entries, edit, and delete entries from the table.

<b>Sort</b>	Sorts the list of database records using either an alphanumeric sort or number values. You can specify four sorts to perform on the list.
<b>Find</b>	Find the next instance of the text you enter. Select to look in the entire table or a specific field. Select to match the entire field, part of the field, or the beginning of the field with the entered text. Make it case sensitive by clicking Match case.
<b>Replace</b>	Indicates to replace the find value with the new text string that you specify.
<b>Filter</b>	Filters the listing based on certain values in the table. Picking the blank entry in the list removes the filter for that field. After you define the values to filter, apply the filter in the database editing window.
<b>Edit</b>	Displays the Edit Record dialog box for modifying the existing record in the database.
<b>Add New</b>	Displays the Edit New Record dialog box for entering a new record into the database.
<b>Add Copy</b>	Displays the Edit Copied Record dialog box for modifying and copying the record to make a new record. You cannot have two duplicate copies in the database.
<b>Delete</b>	Removes the selected record from the database.

## Table Format

<b>SEARCHORDER</b>	Arranges the order of the records so that certain wildcard patterns are used before others. For example, the contact symbol HCR217F.dwg matches two different SYMBOL values, <b>"*217F*"</b> and <b>"*21*"</b> . Since <b>"*217F*"</b> has a lower SEARCHORDER value, its GRAPHIC symbol is used in the cross-reference table.
<b>SYMBOL</b>	<p>The contact symbol block name or wild card to map to a graphic block name. The following codes are supported to handle special cases.</p> <ul style="list-style-type: none"><li>■ <b>A+B</b> map one graphic block where two separate NO/NC contacts exist for a given coil and the pins match up with a Form-C in the PINLIST for that coil.</li><li>■ <b>SP=NO</b> map a spare normally open contact</li><li>■ <b>SP=NC</b> map a spare normally closed contact</li><li>■ <b>SP=&lt;&gt;</b> map a spare convertible contact</li><li>■ <b>SP=NONC</b> map a spare form-c contact</li><li>■ <b>SP=NO2</b> map a spare normally open contact that is part of a form-c definition</li><li>■ <b>SP=NC2</b> map a spare normally closed contact that is part of a form-c definition</li></ul> <hr/> <p><b>NOTE</b> The spare contacts are shown only if the cross-reference option to display the unused child contacts is selected.</p>
<b>GRAPHIC</b>	The name of the block (.dwg) file that is inserted into the table cell when the block name of the contact matches the SYMBOL value.
<b>COMMENTS</b>	Explains the purpose of the wild-card pattern and graphic.

## Update cross-reference tables

The table style cross-referencing provides support for replaceable parameters to define and display in the table title. Some AutoCAD Electrical commands take it into account when modifications are made to the drawing and the cross-reference table is later updated.

<b>Delete Component</b>	If a component with a cross-reference table is deleted, the table is also deleted from the drawing.
-------------------------	---

<b>Component Retag</b>	If a component is retagged (retag, move component, move circuit, edit component) the cross-reference table updates if the tag is part of the title.
<b>Edit Component</b>	If a replaceable parameter is modified for a component that has a cross-reference table, the table title updates to reflect the changes.
<b>Copy Catalog Assignment</b>	When copying a different catalog number to a parent symbol, the PINLIST and contact count may update and the cross-reference table updates in real time.
<b>IEC Tagging Mode</b>	If IEC drawing-wide Location or Installation values change, the cross-reference table title updates to reflect the changes.
<b>Copy Circuit</b>	If a circuit with a cross-reference table is copied, the table title updates with the new tag values.
<b>Insert Component</b>	If inserting a parent component with a cross-reference table, the table inserts at the cross-reference attribute locations (XREF and XREFNO). If inserting a child component, the cross-reference table updates for the parent component.
<b>Scout</b>	If scouting a parent component with a cross-reference table, the table also scouts along the wire.

---

**NOTE** If you change the component catalog number or add a multiple BOM catalog number to the component (both change the Pin List data) the cross-reference table updates as soon as you exit out of the Insert/Edit Component dialog box. Additionally, if you modify the Pin List manually on the parent component, the cross-reference table updates with the new pin numbers and the modified contact count once the Insert/Edit Component dialog box is exited.

---

**Commands that do not support real-time cross-reference updates include:**

- Component Find and Replace
- Spreadsheet Export and Import

### **Set cross-referencing display**

Cross-reference settings are supported at the project, drawing, and component level. Changes you make to the settings are automatically updated in real time.

---

**TIP** To set display settings for a specific component that are different from the drawing, use the Copy/Add Component Override tool.

---

- 1 Click Project tab ► Project Tools panel ► Manager. 
- 2 In the Project Manager, right-click the project or drawing name, and select Properties.

---

**NOTE** Selecting the project applies changes to the project definition file and not the drawing. Apply the settings to drawings to see display changes.

---

- 3 Click the Cross-references tab. In the Component Cross-reference Display section, select Text, Graphical, or Table Format and click Setup.
  - **Text Format:** Displays cross-referencing as text with any user-defined string as a separator between references on the same attribute.
  - **Graphical Format:** Displays cross-referencing using the AutoCAD Electrical graphical font or using contact mapping edit boxes while displaying each reference on a new line.
  - **Table Format:** Displays cross-referencing in a table object so you can define the columns to display.
- 4 Specify the format for the cross-reference display.

The Preview box shows an image that shows an example of the cross-referencing format being defined.
- 5 Select the display options.

---

**TIP** See the Reference topics for each cross-reference display format to learn about the various display options.

---

- 6 If you selected to use the Table Format style, specify the table style and table title. Select a table style from the list. The list initially displays table styles from the active drawing and from the table styles drawing. Click Browse to select a drawing with the desired table style. Once selected, the table style is applied to the Table Styles drawing.

To set the table title:

- Select the allowable replaceable parameter entry from the selection list

- Enter the replaceable parameter

- Enter text

7 Click OK.

If you selected to use the Table Format style, the table location is based on the cross reference attribute position. You can move the table to any location on the drawing and the table remains in the new position for that symbol.

## Table cross-reference format setup

This format displays cross-referencing in a table object that automatically gets updated in real time, so you can define the columns to display. To display component cross-referencing in a table, select a predefined table style and define the column labels to display.

 **Ribbon:** Project tab ► Project Tools panel ► Manager. 

 **Toolbar:** Main Electrical 2 

 **Menu:** Projects ► Project ► Project Manager

 **Command entry:** AEPROJECT

In the Project Manager, right-click the project or drawing name, and select Properties. Click the Cross-references tab. In the component Cross-reference Display section, select Table Format, and click Setup.

If new contacts are added to the component, the cross-referencing table automatically updates. The table location is based on cross-reference attributes. You can move the table to any location on the drawing and the table remains in the new position.

If you change the table setup once a table has been inserted onto the drawing, run the Component Cross-reference tool to update the table.

---

**NOTE** You can also access this dialog box by selecting Schematic tab ► Insert Components panel ► Icon Menu. Select the component type to insert and specify the insertion point on the drawing. In the Insert/Edit Component dialog box, Cross-reference section, select Component override, and click Setup. In the Cross-reference component override dialog box, select Table Format, and click Setup.

---

## Format

**Graphic Font** Displays the cross-reference format using a graphical font. Select to use the JIC font or the IEC/GB/JIS font. The setting is applied to the graphical font regardless of the tagging mode assigned in the project properties.

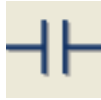

The JIC image font style displays the cross-referencing using the JIC style normally open, normally close, and Form C contact types.



The IEC/GB/JIS image font style displays the cross-referencing using the IEC style normally open, normally close, and Form C contact types.

**Contact Mapping** Displays the cross-reference format using cross-referencing type values (NO, NC, NONC). Enter the format into the edit boxes.

**Symbol Mapping** Displays the cross-reference format using mapped graphic block drawings. Click [Edit](#) on page 830 to modify the mapping settings.

See [Learn about table cross-reference formats](#) on page 820 for examples of the format styles.

## Preview

Displays an image that shows an example of the cross-referencing format being defined.

## Options

<b>Display Parent (Coil)</b>	Displays the reference information for the parent component inside the cross-reference format.
<b>Display Unused Children (Contacts)</b>	Displays the child symbols that are not referenced or being used in the project pin list.
<b>Separate Reference</b>	Displays each unused child symbol in its own reference.
<b>Contact Count Totals</b>	Displays the total count of all unused child symbols in a single reference.



**Fill Reference With**

Specifies what to display in the unused reference position for both Separate and Contact Count options. If left empty, a space appears where the referencing would be displayed. For example if you enter the text "SP" for spares, "SP" displays in the referencing.

**Table Style**

Table styles are defined within a drawing file to determine the size, shape, style, and font of a table object. There is always a table style on a drawing. The standard table style cannot be deleted. Various style drawing files that determine the drawing-related settings are provided with AutoCAD Electrical. The Table Styles drawing (TableStyle.dwg) defines a series of table objects that are used in the selection process and then copied to the drawing files.

Select a table style from the list. The list initially displays table styles from the active drawing and the TableStyle.dwg. Click Browse to select a drawing with the desired table style. Once selected, the table style can be applied to the Table Styles drawing. If the selected style does not exist on the TableStyle.dwg it is copied to it. When a drawing is referenced the style is then copied from the TableStyle.dwg.

Click Define Columns to open the Cross-reference Table Data Fields to Display dialog box to define the columns for the table cross-referencing.

**Table Title**

Controls the replaceable parameters and carriage returns. Select the allowable replaceable parameter entry from the selection list, enter the replaceable parameter to use, or enter text for the table title. Add a carriage return inside of the string by using "|" anywhere in the Table Title edit box.

---

**NOTE** If the replaceable parameter does not include a value from the drawing, a blank space is displayed in the table title. If the title line is left blank, the table does not show the title row.

---

## Use stand-alone cross-reference symbols

You use stand-alone cross-reference symbols just as you would wire source/destination arrow symbols but without the wires. Insert a source reference symbol, and then tie one or more destination reference symbols to

it. They can be on the same drawing or scattered across the project drawing set.

## Insert stand-alone cross-reference symbols

You use stand-alone cross-reference symbols just as you would wire source/destination arrow symbols but without the wires. Insert a source reference symbol, and then tie one or more destination reference symbols to it. They can be on the same drawing or scattered across the project drawing set.

- 1 Click Schematic tab ► Insert Components panel ► Dashed Link Line



drop-down ► Insert Stand-Alone Cross-Referencing.

- 2 On the Insert Component dialog box, select the cross-reference symbol to insert from the Symbol Preview window.  
You can also enter the symbol to insert in the Type it edit box or click Browse to select a symbol to insert.
- 3 Specify the insertion point on the drawing.
- 4 On the Stand-alone Source Cross-Reference Symbol dialog box, specify the unique name for the source/destination pair. You can select the code:
  - From a list of recently used codes.
  - From a list of codes on the active drawing.
  - From a list of codes in the active project.
  - From a destination cross-reference symbol.
- 5 Click OK.

## Create stand-alone cross-reference symbols

- 1 Create a blank drawing file and save it following the library symbol naming conventions.
- 2 Copy a .dwg file of an existing symbol to the new file.
- 3 Edit and save the file.
- 4 Add the file to the icon menu.

### Update stand-alone cross-reference symbol annotations

- 1 Click Schematic tab ► Edit Components panel ► Modify Component Cross-Reference drop-down ► Update Stand-Alone Cross-Referencing.



The Update Wire Signal and Stand-Alone Cross-Reference dialog box displays.

- 2 Specify whether to update the cross-reference annotation between pairs of stand-alone cross-reference symbols.
- 3 Specify to update the cross-references for the entire drawing or one at a time.
- 4 Click OK.

### Insert component

This icon menu can be modified, expanded, or replaced with a custom menu. You can change the default icon menu using the Library and Icon Menu Paths section of the [Project properties: project settings tab](#) on page 204. Use the Icon Menu Wizard to modify the menu. The default icon menu can also be redefined in *wd.env*. Add entry "WD\_MENU" for schematic icon menu and "WD\_PMENU" for panel layout icon menu.

#### Insert Component

 **Ribbon:** Schematic tab ► Insert Components panel ► Insert Components

drop-down ► Icon Menu.



 **Toolbar:** Main Electrical

 **Menu:** Components ► Insert Component

 **Command entry:** AECOMPONENT

## Multiple Insert (Icon Menu)

 **Ribbon:** Schematic tab ► Insert Components panel ► Multiple Insert



drop-down ► Multiple Insert (Icon Menu).



 **Toolbar:** Main Electrical

 **Menu:** Components ► Multiple Insert ► Multiple Insert (Icon Menu)

 **Command entry:** AEMULTI

---

**NOTE** This dialog box is also accessed when inserting Pneumatic, Hydraulic, or P&ID components; in-line wire labels; stand-alone cross-reference symbols; cable markers; and saved circuits.

---

Select an icon picture or the component type from the Menu tree structure. The main menu in the tree structure is displayed as the menu heading just above the menu tree structure.

### Tabs

- Menu: Changes the visibility of the Menu tree view.
- Up one level: Displays the menu that is one level before the current menu in the Menu tree view. This option is unavailable if the main menu is selected in the Menu tree view.
- Views: Changes the view display for the Symbol Preview window and Recently Used window. The current view option is indicated with a check mark. Options include: Icon with text, Icon only or List view.

### Menu

The tree structure is created by reading the icon menu file (.dat). The tree structure is based on the arrangement order of submenus defined in the .dat file.

### Symbol Preview window

Displays the symbol and submenu icons corresponding to the menu or the submenu selected in the Menu tree structure. Clicking on the icon performs one of the following functions based on the icon properties as defined by the .dat file:

- Inserts the symbol or circuit onto the drawing
- Executes a command
- Displays a submenu

---

**NOTE** When you move the cursor over an icon, the icon name and block/circuit/command name display as tooltip information.

---

<b>Recently Used</b>	Displays the last components inserted during the current editing session; the most recently used icon displays in the top. This list follows the view options setting in the symbol preview window (icon only, icon with text or list view). The total number of icons displayed depends on the value specified in the Display edit box.
<b>Display</b>	Specifies the number of icons to display in the Recently Used list box. Enter integer numbers only; the default value is 10.
<b>Vertical/Horizontal</b>	Inserts the icon using a vertical or horizontal orientation. This value is opposite the default ladder rung orientation for the drawing.
<b>No edit dialog</b>	Turns off the Insert/Edit Component dialog box when inserting symbols onto the drawing. To add component detail later, click the Edit Component tool, and select the component to edit.
<b>No tag</b>	Inserts the component, untagged (that is, without assigning a unique Component Tag). The untagged value that displays is the TAG1/TAG2 default value for the component. To add component detail later, click the Edit Component tool, and select the component to edit.
<b>Always display previously used menu</b>	Indicates to display the previously used menu each time you open the Insert Component dialog box. For example, if you insert a push button from the Push Buttons menu, the next time you open the Insert Component dialog box the Push Button menu displays by default.
<b>Scale schematic</b>	Specifies the component block insertion scale. This defaults to the value set in the Drawing Properties ► Drawing Format dialog box. Once set, this value is remembered until reset or until the drawing editing session ends.
<b>Scale panel</b>	Specifies the footprint insertion scale. This defaults to the value set in the Drawing Properties ► Drawing Format dialog box. Once set, this value is remembered until reset or until the drawing editing session ends.
<b>Type it</b>	Manually type in the component block to insert.

**Browse**

Browses to and selects the component to insert.

### **Right-click menus**

#### **Options for the Menu tree structure view**

Right-click on the main menu or submenu in the Menu tree structure view to display the following options:

- **Expand/Collapse:** Toggles the visibility of the menus.
- **Properties:** Opens a Properties dialog box to view the existing menu or submenu properties like the menu name, image, or submenu title. Use the Icon Menu Wizard to change any menu properties.

#### **Options for the Symbol Preview window**

Right-click an icon or in empty space in the Symbol Preview window to display the following options:

- **View:** Changes the view display for the Symbol Preview window and Recently Used window. The current view option is indicated with a check mark. Options include: Icon with text, Icon only or List view.
- **Properties:** (available for icons only) Opens a Properties dialog box to view the existing symbol icon properties like the icon name, image, block names and so on. Use the Icon Menu Wizard to change any icon properties.

### **Pneumatic, Hydraulic, and P&ID icon menus**

The Menu tree structure displays the symbols for the selected component type (pneumatic, hydraulic, or P&ID). The Insert Pneumatic Component, Insert Hydraulic Component, and Insert P&ID Component tools are accessed from the Schematic tab ► Insert Components panel on the ribbon or the Extra Library toolbar.



Insert Pneumatic Component



Insert Hydraulic Component



Insert P&ID Component

## Stand-alone source or destination cross-reference symbol

You use stand-alone cross-reference symbols just as you would wire source/destination arrow symbols but without the wires. Insert a source reference symbol and then tie one or more destination reference symbols to it. They can be on the same drawing or scattered across the project drawing set.

 **Ribbon:** Schematic tab ► Insert Components panel ► Dashed Link Line



drop-down ► Insert Stand-Alone Cross-Referencing.



 **Toolbar:** Cross-Reference

 **Menu:** Components ► Cross-Reference ► Insert Stand-Alone Cross-Reference

 **Command entry:** AESAXREF

Select the cross-reference component to insert and place it on the drawing.

<b>Code</b>	Specifies the unique name for the source/destination pair. This links each source cross-reference symbol to its destination cross-reference symbols.
<b>Sheet</b>	(for Hexagon symbols only) Displays the sheet (Drawing Property) value for the drawing the matching symbol.
<b>Reference</b>	Displays the line reference value for the matching symbol.
<b>Description</b>	(optional) Specifies the description for the symbol.
<b>Recent</b>	Provides a list of source or destination symbols inserted this AutoCAD session.
<b>Drawing</b>	Displays drawing-wide pick lists of all source/destination codes used so far.

<b>Project</b>	Displays project-wide pick lists of all source/destination codes used so far.
<b>Pick</b>	Picks the matching symbol from the active drawing.
<b>OK+ Update Destination</b>	Saves changes and updates the related destination symbols with any changes.

## Update wire signal and stand-alone cross-reference

Updates signal source and destination cross-reference text and wire numbers.

**Ribbon:** Schematic tab ► Edit Wires/Wire Numbers panel ►  ►

 Update Signal References.

**Toolbar:** Signals 

**Menu:** Wires ► Signal References ► Update Signal References

**Command entry:** AEUPDATESIGREF

Update source or destination signals singly, drawing-wide, or project-wide. You can update cross-reference information for 2 types of cross-reference symbols:

- Wire number signal arrow symbols
- Stand-alone cross-reference symbols

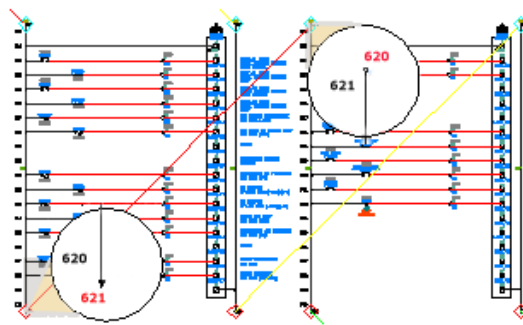



## Wire Signals

<b>Update source/destination cross-references</b>	Updates the from/to cross-reference annotation on each wire network source and destination arrow symbol.
<b>Update source/destination wire number tags</b>	Makes the wire number tags on the destination end match the wire number carried on the source end of each wire signal pair.

## Stand-Alone Cross-Reference Symbols

Set up the desired cross-reference format in the Cross-Reference Format section of the Drawing Properties ► Cross-Reference dialog box. It is on a per-drawing basis.

<b>Update stand-alone cross-reference symbols</b>	Updates the cross-reference annotation between pairs of stand-alone cross-reference symbols. They are wire number signal symbols, but without a WIRENO attribute and do not attach to wires. They can float. See <a href="#">Stand-alone source or destination cross-reference symbol</a> on page 843.
---	--

# Insert dashed link lines

## Insert a dashed link line

Links selected components with a dashed line.

The TAG, description, and cross-referencing attributes of the second through last components you select for linking become invisible. The Unhide Attribute command turns the visibility of the selected attributes back on. Components must have X?LINK attributes to link.

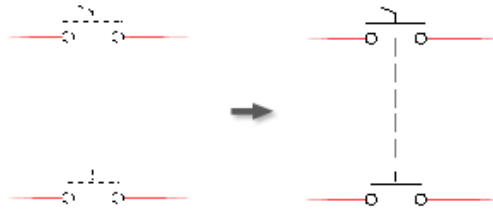

- 1 Click Schematic tab ► Insert Components panel ► Dashed Link Line



drop-down ► Link Components with Dashed Line.

- 2 Select the contacts in the order you want the dashed link line drawn.  
AutoCAD Electrical changes the contact's annotation to invisible and draws a dashed link line from the bottom of the upper contact to the top of the new contact. The line is a polyline drawn on the layer name defined on the Define Layers dialog box.
- 3 (Optional) Use the AutoCAD Layer command to assign a different line type to the layer.
- 4 (Optional) Use the Scoot command to reposition any jog in the dashed link line.
- 5 (Optional) To remove a dashed link line, run the command again, selecting in the same order as before.  
The dashed line toggles off and the hidden attribute annotation reappears.

### See also:

- [Overview of schematic attributes](#) on page 306

### Insert dashed link lines to arrows

This tool draws a dashed line from a component to a "To" arrow symbol.

- 1 Click Schematic tab ► Insert Components panel ► Dashed Link Line

drop-down ► Insert Reference Arrow - To.



- 2 Select the contact to draw the line from.
- 3 Select where the arrow endpoint should be on the drawing.
- 4 Insert a description for the dashed link line in the Description dialog box and click OK.  
The line is a polyline drawn on the layer name defined on the Drawing Properties ► Drawing Format ► Layers:Define ► Define Layers dialog box.
- 5 (Optional) Use the AutoCAD Layer command to assign a different line type to the layer.
- 6 (Optional) Use the Scoot command to reposition any jog in the dashed link line.
- 7 (Optional) Use the AutoCAD Erase command to remove the dashed link line.

### Insert dashed link lines from arrows

This tool draws a dashed line from a component to a "From" arrow symbol.

- 1 Click Schematic tab ► Insert Components panel ► Dashed Link Line

drop-down ► Insert Reference Arrow - From.



- 2 Select the contact to draw the line from.
- 3 Select where the arrow endpoint should be on the drawing.
- 4 Insert a description for the dashed link line in the Description dialog box and click OK.  
The line is a polyline drawn on the layer name defined on the Drawing Properties ► Drawing Format ► Layers:Define ► Define Layers dialog box.
- 5 (Optional) Use the AutoCAD Layer command to assign a different line type to the layer.

- 6 (Optional) Use the Scoot command to reposition any jog in the dashed link line.
- 7 (Optional) Use the AutoCAD Erase command to remove the dashed link line.

## Follow signals

### Follow a signal for a source or destination signal

Use the List Signal Code tool to follow a signal from a specific source or destination symbol.

- 1 Click Schematic tab > Edit Wires/Wire Numbers panel >  >

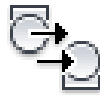

List Signal Code.

- 2 Select the signal marker to list. The signal code dialog box appears. All source and destination references for the signal code are listed in the three boxed groups.
- 3 Review the references for the signal code.
- 4 Click the Surf button to navigate to any of the references.
- 5 Click Cancel when you are finished reviewing the signal references.

### Signal code

Follows a signal from a specific source or destination symbol and lists the signal code references.

-  **Ribbon:** Schematic tab > Edit Wires/Wire Numbers panel >  >

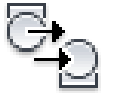

List Signal Code.

-  **Toolbar:** Signals

 **Menu:** Wires ► Signal References ► List Signal Code

 **Command entry:** AELISTSIG

All source and destination references for the signal code are listed in the three boxed groups:

<b>Previous drawings (sheet/reference)</b>	Shows the references on upstream (previous) drawings.
<b>Current drawing</b>	Shows the references on the current drawing.
<b>Downstream drawings (sheet/reference)</b>	Shows references on downstream (next) drawings.
<b>Surf</b>	Navigates to any of the references.

## Show signal paths

### Show signal path

Displays signal source and destination paths on the active drawing.

 **Ribbon:** Schematic tab ► Edit Wires/Wire Numbers panel ►  ►

Show Signal Paths.



 **Toolbar:** Signals

 **Menu:** Wires ► Signal References ► Show Signal Paths

 **Command entry:** AESHOWSIG

Signal paths are drawn using temporary graphics. Redraw to erase.

## Overview of DIN Rails

The Din Rail is generated based on data held in a Microsoft Excel spreadsheet called WDDINRL.XLS. Each row in the main worksheet, DIN\_RAIL, represents a rail type. The Manufacturer, Catalog, and Description fields are used to create the drop-down list on the dialog box. In addition, each rail type has a corresponding worksheet named to match the catalog number. This worksheet

defines some parameters based on the number of slots calculated from the rail length.

### Spreadsheet fields

<b>MFG</b>	Manufacturer.
<b>CAT</b>	Catalog Number.
<b>ASSYCODE</b>	Assembly code.
<b>DESC</b>	Description used for dialog listing only.
<b>RAILWID</b>	Din rail width; distance between the top and bottom rail lines.
<b>RAILCEN</b>	Distance between the din rail centerlines.
<b>RAILCEN1</b>	Distance between the din rail centerlines; used for nonsymmetrical din rails.
<b>RAILCEN2</b>	Distance between bottom center line and the slot centers; used for nonsymmetrical din rails.
<b>RAIL2SLOTZEN</b>	Distance from the origin of the din rail to the center of the slots; used for off-center din rails.
<b>RAIL2ENDBASE</b>	Distance from the origin of the din rail to the din rail bottom; used for off-center din rails.
<b>RAILLENSTD</b>	Standard length of din rail.
<b>RAILLENMIN</b>	Minimum length of rail piece.
<b>SLOTDFS</b>	Distance from the beginning of the din rail to the center of the first slot.
<b>SLOTZEN2ZEN</b>	Distance between slots measured from the center of each slot.
<b>SLOTLEN</b>	Length of each slot. Enter a SLOTLLEN of 0.0 to generate a block without slots.
<b>SLOTWID</b>	Width of each slot.

<b>CHANNEL</b>	Distance from channel line to the origin; repeated for each channel line.
<b>CHANNEL_END</b>	Distance from origin to channel end for each channel.
<b>MIN_SHIFT</b>	Length of rail to shift from one piece of rail to the next to make sure last piece is not less than the minimum length.
<b>NCHOLE</b>	Name of AutoCAD block for the drill hole.
<b>BRKT</b>	Allow standoff brackets, Yes or No. If No, then the button is disabled on the dialog. If Yes, the button is enabled and you can select standoff brackets.
<b>BRKT_NAME</b>	Name of AutoCAD block for standoff bracket.
<b>BRKT_MFG</b>	Manufacturer for standoff bracket. Added as Multi-BOM on the created Din Rail block.
<b>BRKT_CAT</b>	Catalog number for standoff bracket. Added as Multi-BOM on the created Din Rail block.
<b>BRKT_ASMB</b>	Assembly code for standoff bracket. Added as Multi-BOM on the created Din Rail block.
<b>CATALOG_TABLE</b>	Name used to tie into the catalog lookup table. Values are either DIN or WW based on whether the spreadsheet record is a din or wire way. This determines whether the DIN or WW table (of the default_cat.mdb) displays when you click Catalog Lookup on the Panel Layout - Component Insert/Edit dialog box.

### **Parametric building of wire ways**

You can create generic wire way records in the spreadsheet (wddinrl.xls) for parametric building of wire ways. To do so, add the following records in the spreadsheet:

- MFG = PANDUIT
- CAT = Generic
- DESC = Wire duct, 3.25"x3.11" tall, slotted

- RAILLENSTD = 72
- WDBLKNAM = WW
  
- MFG = PANDUIT
- CAT = Generic
- DESC = Wire duct, 3.92"x1.89" tall, slotted
- RAILLENSTD = 78.72
- WDBLKNAM = WW

In the Din Rail dialog box, select one of these records as the Rail Type and click OK. In the Panel Layout - Component Insert/Edit dialog box, Catalog section, click Catalog Lookup. The Parts catalog dialog box now displays wire ways with Manufacturer = PANDUIT and Type = Slotted. Select a suitable wire way from the list.

### Line properties

There may be times that you want to specify a color, linetype, or layer for a particular line entity that makes up the Din Rail. You can do this with a few optional spreadsheet fields. For the 2 end lines, you add 2 columns in your spreadsheet, each called END\_PROP. The first one is for the left end, the second is for the right end. The format is COLOR colorname LAYER layername LTYPE linetype. For example, COLOR 9 LAYER MISC LTYPE HIDDEN2. It is expecting a single space between the values. If you leave the field blank, or leave out one of the properties, it draws the lines using the current defaults. For the channel lines, it works similarly, but the columns should be called CHANNEL\_PROP. Put them in the same order as the CHANNEL values. For example, you want the inner lines to be font HIDDEN2 and the CHANNEL columns are in this order, 0.69 0.49 -0.49 -0.69, this means the inner lines are the second and third channel columns. So the CHANNEL\_PROP columns are:

- First column: leave blank
- Second column LTYPE HIDDEN2
- Third column: LTYPE HIDDEN2
- Fourth column: blank

**END\_PROP**

Use this field to define the properties for the end lines.



CHANNEL\_PROP

Use this field to define the properties for the channel lines.

## Din rail

 **Ribbon:** Panel tab ► Insert Component Footprints panel ► Insert

Footprints drop-down ► Icon Menu.



 **Toolbar:** Panel Layout

 **Menu:** Panel Layout ► Insert Footprint (Icon Menu)

 **Command entry:** AEFOOTPRINT

Select DIN Rail from the list.

Once the information is entered and you click OK, the Din Rail is generated. Each Din Rail section is created as a separate block. If you selected Standoff brackets, each bracket is a separate block. Some AutoCAD Electrical information is added to each block so it can be treated as an AutoCAD Electrical Panel entity. The AutoCAD Electrical edit dialog appears for the first Din Rail section and the first bracket, if applicable.

<b>Rail Type</b>	Lists the rail types to select from.
<b>Origin and length</b>	Specifies the origin and length of the component. Type the information into each edit box or click Pick Rail Info to pick the origin on your drawing and then drag the mouse to define the rail length.
<b>Orientation</b>	Specifies to orient the din rail horizontally or vertically.
<b>Scale</b>	Specifies the scale to use for the din rail.
<b>Panel mounting</b>	Specifies to mount the panel at NC holes, standoffs, or none.

## Overview of user data records

AutoCAD Electrical supports a user table in the project database. You can add your own application data to any AutoCAD Electrical block insert (components,

footprints, wire numbers, terminals, wire jump arrows). A copy of this information is extracted and maintained in a USER table in the project database. This allows you to do queries on the project database file (in Microsoft Access format) and access all of this user information carried on all entities project-wide. This data is stored on the entities as invisible extended entity data. You are free to use this data in any way you see fit.

Examples: storing explicit wire sequencing information, cable or wire lengths, routing information, storing special parts information, descriptions, or MRP data, storing engineering notes, setup, or maintenance information, and so on.

Each application data record that you add to an entity can be up to 255 characters long. A single AutoCAD Electrical entity can carry several hundred of these records. Each record is tracked on the entity by entity handle plus a three digit record number beginning at "000". This same information is automatically maintained, project-wide, by AutoCAD Electrical in the user table of the project's database file.

### Edit user table data

You can add, edit, or remove free-form user data records attached to the selected block insert. These records are stored in a user database table in the project database file.

 **Ribbon:** Schematic tab ► Edit Components panel ► Edit Components

drop-down ► User Table Data. 

 **Toolbar:** Edit Component 

 **Menu:** Components ► Component Miscellaneous ► Edit User Table Data

 **Command entry:** AEUSERTABLE

<b>Record number</b>	Lists the record number for the selected block insert.
<b>Data</b>	Lists the user data for the record number.
<b>Edit</b>	Specifies the new data for the selected record number. Note that there is a 255 character maximum per record.
<b>Add new</b>	Adds a new user data record. A separate dialog box displays where you can enter the record data and number.

**Delete record**

Removes the selected record number from the database. If no user data records are found on the block insert, an alert is displayed in the dialog box prompting you to add a new record.

## Wire Jumpers

### Define wire jumpers

#### Define wire jumpers

You can create internal jumpers on a selected component using the Add/Edit Internal Jumper tool. When wire numbers are inserted using AutoCAD Electrical, these internal jumpers are read and wire numbers are assigned accordingly.

If you select to jumper two pins on a component together, an alert displays indicating that internal jumpering will cause a conflict with the existing wire number assignments. If you click Continue, an internal jumper inserts between the two pins on the component; you need to rerun the Insert Wire Numbers tool to reconcile these two different wire numbers now jumpered together. If you click Cancel, the internal jumper data is not inserted.

---

**NOTE** You can keep jumpers from displaying in Wire From/To reports by placing the jumpers on a layer that contains the substring "JUMPER."

---

#### Add wire jumpers from a list

- 1 Click Schematic tab ► Edit Components panel ► Edit Components



drop-down ► Internal Jumper.

- 2 Select the component.
- 3 Select terminals from the list.  
Drag your mouse to select contiguous terminals or use the CTRL button to select noncontiguous terminals.
- 4 Click Add.

### Add wire jumpers by picking

- 1 Click Schematic tab ► Edit Components panel ► Edit Components



drop-down ► Internal Jumper.

- 2 Select the component.
- 3 Click Pick. The dialog closes. You can select as many terminals as you want.  
Try to select as near the terminal as you can since AutoCAD Electrical finds the closest connection terminal to your selected point.
- 4 After you select the terminals, press Enter and the dialog displays.  
Notice that the selected terminals are highlighted in the list.
- 5 Click Add to finish defining the jumper.

### Change an existing jumper assignment

- 1 Click Schematic tab ► Edit Components panel ► Edit Components



drop-down ► Internal Jumper.

- 2 Select the component.
- 3 Select the jumper from the list on the right.  
Once selected, the terminals that are part of this jumper assignment are highlighted on the terminal list.
- 4 Reselect the terminals to be jumpered, using the Shift and CTRL keys as needed.
- 5 Click Update once the appropriate terminals are highlighted.

### Wire jumpers

You can add, change, or delete internal jumpers on a selected component. When wire numbers are inserted, these internal jumpers are read and wire numbers are assigned accordingly.

If you select to jumper two pins on a component together, an alert displays indicating that internal jumpering will cause a conflict with the existing wire number assignments. If you click Continue, an internal jumper inserts between

the two pins on the component; you need to rerun the Insert Wire Numbers tool to reconcile these two different wire numbers now jumpered together. If you click Cancel, the internal jumper data is not inserted.

 **Ribbon:** Schematic tab ► Edit Components panel ► Edit Components

drop-down ► Internal Jumper.



 **Toolbar:** Edit Component

 **Menu:** Components ► Component Miscellaneous ► Add/Edit Internal Jumper

 **Command entry:** AEINTERNALJUMPER

<b>Add</b>	Adds an internal jumper assignment.
<b>Update</b>	Changes an existing jumper assignment.
<b>Delete</b>	Removes the selected jumper assignment from the list.
<b>Pick</b>	Selects the terminals to add to a jumper assignment. Try to select as close to the terminal as you can. AutoCAD Electrical finds the closest connection terminal to your selected point.
<b>Show Jumpers</b>	Displays the current jumper assignments. AutoCAD Electrical draws temporary lines between the jumpered terminals. These graphics disappear when you perform a Regen.



# Component Attribute Tools

# 11

## Edit attribute values

### Edit the attribute text value of a component

You can use three different tools to edit component information.

#### Using the Edit Component tool

The standard way is to use the regular Edit Component command and edit the tag value from the Insert/Edit Component dialog box.

- 1 Click Schematic tab ► Edit Components panel ► Edit Components



drop-down ► Edit.

- 2 Select the component to edit.
- 3 Edit the tag value in the Insert/Edit Component dialog box.
- 4 Click OK to complete the edit.

#### Using the Edit Selected Attribute tool

Lets you pick right on the attribute. This tool also works on invisible attributes. It finds and displays the closest attribute to your pick point on a block insert.

- 1 Click Schematic tab ► Edit Components panel ► Modify Attributes



drop-down ► Edit Selected Attribute.

- 2 Select the attribute to edit.  
A dialog box displays and lets you type in a new attribute value.
- 3 Enter a new attribute value in the Edit Attribute dialog box.  
Click Pick to select another attribute whose text you want to use for the selected attribute. You can also click the arrow keys to increment or decrement the attribute value.
- 4 Click OK.

To edit an invisible attribute: pick on the block insert near where the invisible attribute is located. AutoCAD Electrical finds and displays the nearest attribute of your pick point. AutoCAD Electrical displays an "x" at the origin of the attribute.

### Using the Move/Show Attribute tool

You can use the AutoCAD Electrical Move/Show Attribute command to edit the attribute text of a component.

- 1 Click Schematic tab ► Edit Components panel ► Modify Attributes



drop-down ► Move/Show Attribute.

- 2 Pick on the graphics of the component (not on the attribute text itself; otherwise it flips into Attribute Move mode). If there are no graphics to pick on (such as wire number block/attribute or ladder line reference block/attribute), type "B" and space and then pick on any attribute on the block insert. This forces the command into attribute display mode.  
The Show/Hide Attributes dialog box opens, listing all of the attributes and their values of the component.
- 3 Check the Edit Attributes box in the upper right-hand corner of the dialog box.
- 4 Select the attribute you want to edit from the list.  
A dialog box opens and lets you type in a new attribute value.



- 5 Type in a new attribute value in the Edit Attribute dialog box.  
You can click the arrow keys to increment or decrement the attribute value.
- 6 Click OK.

---

**NOTE** You can also use any attribute editing command to edit an AutoCAD Electrical attribute values of the component. For example, use the AutoCAD DDATE command.

---

## Edit attribute

This tool lets you edit the text an attribute by picking right on the attribute. A dialog box pops up and you type in a new attribute value. This tool also works on invisible attributes. It finds and displays the closest attribute to your pick point on a block insert.

 **Ribbon:** Schematic tab ► Edit Components panel ► Modify Attributes

drop-down ► Edit Selected Attribute.

 **Toolbar:** Edit Attributes

 **Menu:** Components ► Attributes ► Edit Selected Attribute

 **Command entry:** AEEDITATT

<b>Attribute value</b>	Specifies the attribute text. You can click the arrow keys to increment or decrement the attribute value.
<b>Pick</b>	Selects another attribute whose text you want to use for the selected attribute.

## Force attributes to layers

### Force attributes to a different layer

This tool changes the layer assignment for selected attributes.

- 1 Click Schematic tab ► Edit Components panel ► Modify Attributes

drop-down ► Change Attribute Layer.



- 2 Specify the target layer:
  - Type the name in the box.
  - Click List to select from a list of layers in the active drawing.
  - Click Wires to change to the layer used for wire numbers on wires. The default layer is WIRENO. It is defined on the WIRENO\_LAY attribute of the WD\_M block.
  - Click Terminals to change to the layer used for wire numbers on terminals and source or destination signal arrows. The default layer is WIREREF. It is defined on the WD\_M WIREREF\_LAY attribute of WD\_M block.
- 3 Click OK.
- 4 Select the attributes to change to the target layer.

---

**NOTE** Windowing of attributes is not supported. You must pick them individually.

---

## Force attribute/text to a different layer

This tool changes the layer assignment for selected attributes.

 **Ribbon:** Schematic tab ► Edit Components panel ► Modify Attributes

drop-down ► Change Attribute Layer.



 **Toolbar:** Edit Attributes



 **Menu:** Components ► Attributes ► Change Attribute Layer

 **Command entry:** AEATTLAYER

Change to Layer

Specifies the target layer.

<b>List</b>	Lists the layers in the active drawing. Select a layer from this list or enter the layer name in the Change to Layer box.
<b>Wires</b>	Forces the tool to change to the layer used for wire number text placed on wires. The default layer is WIRENO. It is defined on the WIRENO_LAY attribute of the WD_M block.
<b>Terminals</b>	Forces the tool to change to the layer used for wire number text placed on terminals and source or destination signal arrows. The default layer is WIREREF. It is defined on the WIREREF_LAY attribute of the WD_M block.

## Manipulate component text

### Find, edit, or replace component text

- 1 Click Schematic tab ► Edit Components panel ► Retag Components



drop-down ► Find/Edit/Replace Component Text.

- 2 Choose to process either the current drawing or the project and click OK. The drawing or project set is scanned to find all the AutoCAD Electrical components and the current attribute text values.
  - If you chose to process the project, select the drawings to process and add them to the Drawings to Process list. Click OK to continue the operation.
  - If you chose to process the drawing by picks, select the components to process and press Enter. The Find/Edit/Replace dialog box displays, allowing you to define your search and replace parameters.
- 3 Click the Find check box next to the attribute you want to find.
- 4 Enter the attribute value or click the List button to select the value from a list of current text values.
- 5 Click the Replace check box for the selected attribute and type a new text string in the edit box.

- 6 Select to find and replace the exact text value or substrings within the attribute value.
- 7 Click Start Search to begin the find and replace operation. Each found match is displayed in a separate dialog box. You can edit, replace, skip to the next, or replace all of the found values.

### An example of search criteria

To change all of the Location Codes marked "PNL1" to "PNL2A" you would:

- Set the Location Code find value to "PNL1."
- Set the Location Code replace value to "PNL2A."
- Click All so the text is only replaced if the entire text value matches the find value.

### Find/edit/replace (drawing or project)

Edits component text and catalog values using a find/edit/replace operation.

 **Ribbon:** Schematic tab ► Edit Components panel ► Retag Components

drop-down ► Find/Edit/Replace Component Text. 

 **Toolbar:** Retag

 **Menu:** Components ► Component Tagging ► Find/Edit/Replace Component Text

 **Command entry:** AEFINDCOMPTXT

Find and replace component values, or find and replace substrings within those values. Process the active drawing or the project drawing set. Updates only the components on the drawings selected to process.

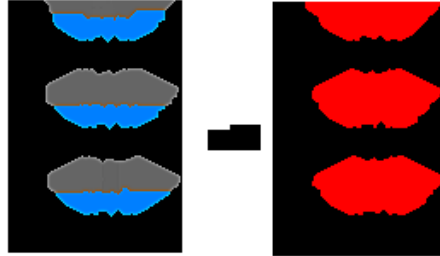

<b>Find</b>	Specifies the value to find. Initially, only the Find (F) toggles are enabled.
<b>Replace</b>	Replaces the find value with the new text string that you specify.
<b>List</b>	Displays a list of the current text values for the selected attribute. Select from this list to define your find parameter.
<b>All</b>	Replaces the text only if the entire text value matches the find value.
<b>Part</b>	Replaces the text if any part of the text value matches the find value.
<b>Start search</b>	Starts the search in the drawing or project for the find values that are specified. Each found match is displayed. You can edit, replace, skip to the next, or replace all of the values with the specified replace value.

---

**NOTE** This tool does not support wildcard characters.

---

### **Find/edit/replace component text**

Edits component text and catalog values using a find/edit/replace operation.

 **Ribbon:** Schematic tab ► Edit Components panel ► Retag Components

drop-down ► Find/Edit/Replace Component Text.



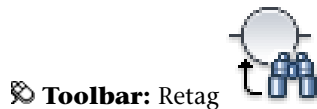

**Toolbar:** Retag

**Menu:** Components ► Component Tagging ► Find/Edit/Replace Component Text

**Command entry:** AEFINDCOMPTXT

Decide if you want to run the component retag across selected components, the active drawing, or the entire project.

## Manipulate terminal text

### Find or replace terminal text

- 1 Click Schematic tab ► Edit Components panel ► Retag Components

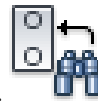

drop-down ► Find/Replace Terminal Text.

- 2 Select to replace the Full, exact match, or a substring match.
- 3 If you chose to perform a substring match, select whether only the first occurrence within the text value should be replaced.
- 4 Define your find and replace with values.
- 5 Click OK to begin the find and replace operation.
- 6 Choose to process either the current drawing or the project and click OK.
  - If you chose to process the project, select the drawings to process and add them to the Drawings to Process list. Click OK to continue the operation.
  - If you chose to process the drawing by picks, select the components to process and press Enter.
- 7 The drawing or project set is scanned to find all the terminals and the current terminal text values. The find value is replaced with the specified replace value.

### Find/replace terminal text

This tool lets you find and replace terminal number text values or find and replace substrings within those values. You can do it on a selection from the active drawing, the entire active drawing, or across the project drawing set.

 **Ribbon:** Schematic tab ► Edit Components panel ► Retag Components

drop-down ► Find/Replace Terminal Text. 

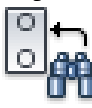
 **Toolbar:** Retag

 **Menu:** Components ► Component Miscellaneous ► Find/Replace Terminal Text

 **Command entry:** AEFINDTERMTEXT

<b>Full, exact match</b>	Specifies to replace the text only if the entire text value matches the find value.
<b>Substring match</b>	Specifies to replace the text if any part of the text value matches the find value.
<b>First occurrence only</b>	Specifies that only the first occurrence within the text value should be replaced.
<b>Find</b>	Specifies the value you wish to find.
<b>Replace with</b>	Specifies the text string to replace the find value with.

## Move description values

### Push descriptions up or down

AutoCAD Electrical supports three lines of description text on schematic components. If some only have one or two lines of description, the description may seem to float too high above the device. You can use these tools to move the description attribute values up or down to another position.

1 Enter AEUPATTRIBDESC at the command prompt.

or

Enter AEDOWNATTRIBDESC at the command prompt.

- 2 Select the schematic components to process.
  - **Push Description Up:** DESC2 and DESC3 are pushed up to the DESC1 and DESC2 attribute positions when blanks are found.
  - **Push Description Down:** DESC1 and DESC2 are pushed up to the DESC2 and DESC3 attribute positions when blanks are found.

## Move attributes

### Move component attributes

- 1 Click Schematic tab ► Edit Components panel ► Modify Attributes



drop-down ► Move/Show Attribute.

- 2 Select the attributes to move and press Enter.  
You can pick the components individually or by windowing. The attributes highlight with a rectangular box drawn around them.
- 3 Select the base and insertion points for the move. The attribute follows your cursor and is automatically moved to the selected position.  
The attributes remain tied to the block inserts.

## Hide attributes

### Hide attributes

Pick on the graphic of a target block insert to display a listing of all attribute names and values. You can switch attributes between hidden and visible or you can edit individual attribute values.

- 1 Click Schematic tab ► Edit Components panel ► Modify Attributes



drop-down ► Hide Attributes (Single Picks).

or



Click Schematic tab ► Edit Components panel ► Modify Attributes



drop-down ► Hide Attributes (Window/Multiple).

- 2 Select the attributes to hide or pick on block graphics to display a list of attributes. The attribute is hidden immediately after it is selected.  
You can window attributes to hide by typing W and [space]. Do a crossing window (right to left) to capture the attributes you want to hide.
- 3 (Optional) Type U and [space] to unhide the attribute.

## Show attributes

### Show attributes

- 1 Click Schematic tab ► Edit Components panel ► Modify Attributes



drop-down ► Unhide Attributes (Window/Multiple).

- 2 Select the attributes to display by drawing a crossing window around the attributes on the drawing.
- 3 Press Enter.
- 4 Select one or more attribute to flip to visible from the list.
- 5 Click OK.

## Rotate attributes

### Rotate component attributes

- 1 Click Schematic tab ► Edit Components panel ► Modify Attributes



drop-down ► Rotate Attribute.

- 2 Select the attribute text, text, or MTEXT string to rotate 90 degrees from its current orientation.

After rotation, press M and [space] to flip into the Move Attribute mode.

## Change attribute justification

### Change attribute justification

Use this tool to change the justification of wire number text, component description text, or any attribute.

- 1 Click Schematic tab ► Edit Components panel ► Modify Attributes



drop-down ► Change Attribute Justification.

- 2 Select the appropriate justification from the list, or click Pick Master to select an attribute on the drawing that has the justification you want to use.
- 3 Select the attributes or text objects one at a time, or enter W, and then window your objects.
- 4 Click OK.

### Change attribute/text justification

Use this tool to change the justification of wire number text, component description text, or attributes.

-  **Ribbon:** Schematic tab ► Edit Components panel ► Modify Attributes



drop-down ► Change Attribute Justification.

-  **Toolbar:** Edit Attributes

-  **Menu:** Components ► Attributes ► Change Attribute Justification

-  **Command entry:** AEATTJUSTIFY

Select Justification

Lists the justification choices to choose from.

**Pick Master**

Selects an attribute or text entity on the drawing whose justification you want to use.

Once you select your attributes or text objects, each object updates to match the selected justification.

## Change attribute text style

### Change attribute text style

Use this tool to adjust the font assignment (either project-wide or drawing-wide) to the text style “WD” or “WD\_IEC.”



- 1 Click Project tab ► Project Tools panel ► Utilities.
- 2 In the Project-Wide Utilities dialog box, Change Attribute section, select Change Style and click Setup.
- 3 In the Project-Wide AutoCAD Electrical Style Change dialog box, select the font name to apply to text style WD or WD\_IEC and click OK.
- 4 In the Project-Wide Utilities dialog box, click OK.
- 5 In the Batch Process Drawings dialog box, select to process the project and click OK.
- 6 In the Select Drawings to Process dialog box, select to process specific files or click Do All to process all of the drawings in the active project. Click OK.

AutoCAD Electrical processes the selected drawings and adjusts the text style WD or WD\_IEC to the specified font name.

## Change attribute text size

### Change attribute text size

To make permanent changes to the symbol text heights, adjust the attribute definitions on the library symbols themselves.

### Use the change attribute size utility

- 1 Click Schematic tab ► Edit Components panel ► Modify Attributes



drop-down ► Change Attribute Size.

- 2 Select your new attribute size by either picking on a similar text or attribute entity or by manually entering the size value into the edit box.
- 3 Enter the new width factor into the edit box. Make sure that you click to apply the width.
- 4 Select to change the attribute name by picking individual attributes, by type, or by typing a specific attribute name.
  - If you chose to select one attribute at a time, select the attributes in the drawing. The attribute text automatically changes to the new attribute size.
  - If you chose to change all attributes of a certain type, select an example attribute and window the entire drawing. It finds and adjusts all attributes of the same name to your specified size.
  - If you chose to type in an attribute name, type the name in the edit box. (Wildcards are allowed.) You can include a series of attribute names to match by separating each attribute name with a semicolon.
- 5 Press OK and window the entire drawing.
- 6 Press Enter.

### Use the project-wide utilities



- 1 Click Project tab ► Project Tools panel ► Utilities.
- 2 In the Project-Wide Utilities dialog box, Change Attribute section, select Change Attribute Size and click Setup.
- 3 In the Project-Wide Attribute Size Change dialog box, select the attribute types to change.
- 4 Enter the text height and optional width factor and click OK.
- 5 In the Project-Wide Utilities dialog box, click OK.

- 6 In the Batch Process Drawings dialog box, select to process the project and click OK.
- 7 In the Select Drawings to Process dialog box, select the drawings to process and click OK.

AutoCAD Electrical processes the selected drawings and adjusts the target attributes to the specified value.

### Use the squeeze and stretch text utilities

Use the Squeeze attribute tool to compress an attribute to make it fit into a tight spot (such as between closely spaced components). Use the Stretch attribute tool to expand an attribute. Each click on the attribute dynamically changes the width factor of the attribute by 5%.

- 1 Click Schematic tab ► Edit Components panel ► Modify Attributes

drop-down ► Squeeze Attribute/Text.



- 2 Select the attribute text to change.  
The text is automatically compressed.

- 1 Click Schematic tab ► Edit Components panel ► Modify Attributes

drop-down ► Stretch Attribute/Text.



- 2 Select the attribute text to change.  
The text automatically stretches.

### Change attribute size

Use this tool to change attribute text size quickly when components or wire numbers were already inserted onto your drawings.

-  **Ribbon:** Schematic tab ► Edit Components panel ► Modify Attributes

drop-down ► Change Attribute Size.





 **Toolbar:** Edit Attributes

 **Menu:** Components ► Attributes ► Change Attribute Size

 **Command entry:** AEATTSIZE

<b>Pick</b>	Selects the new attribute size by picking a similar text or attribute.
<b>Size</b>	Specifies the attribute size value.
<b>Width</b>	Specifies the attribute width value.
<b>Apply</b>	Applies the new size or width values to the selected attributes.
<b>Single</b>	Changes the size of the attributes as you select them.
<b>By name</b>	Changes all attributes of a certain type. Select an example attribute for AutoCAD Electrical to determine the name of the attribute. All attributes of the same name are found and adjusted to your specified size.
<b>Type it</b>	Specifies an attribute name for AutoCAD Electrical to match, wildcard characters are allowed. Window an area containing the attributes you want changed. All attributes that match the typed name are found and adjusted to the specified size. For example, you want to change all the description attributes on all the PLC modules on your drawing. Select "Type it," and then enter "DESC*" for the attribute name. Window the entire drawing. You can include a series of attribute names to match by separating each attribute name with a semi-colon. (Example: "DESC*;TAG*")

## Rename an attribute

### Rename attribute

Renames an attribute on a single instance of an inserted block.

- 1 Click Schematic tab ► Edit Components panel ► Modify Attributes

drop-down ► Rename Attribute.



- 2 Select directly on the attribute you want to rename.
- 3 Enter the new attribute name.
- 4 Press Enter.

## Add attributes to blocks

### Add an attribute to a block

Use this tool to add an attribute to one insert instance of a block. The block does not need to be an AutoCAD Electrical block.

- 1 Click Schematic tab ► Edit Components panel ► Modify Attributes

drop-down ► Add Attribute.



- 2 Select the block.
- 3 Define the attribute name, value, height, justification, and visibility.
- 4 Click OK to create the attribute.
- 5 Select the attribute location on the drawing.

---

**NOTE** Added attributes do not become part of the block definition. They disappear during the Explode command and when inserting another instance of the same block.

---

### Add attribute

Adds a new attribute to an instance of an AutoCAD Electrical block already inserted into the drawing file. The attribute can be user-defined or an AutoCAD Electrical-specific attribute.

 **Ribbon:** Schematic tab ► Edit Components panel ► Modify Attributes

drop-down ► Add Attribute.



 **Toolbar:** Edit Attributes

 **Menu:** Components ► Attributes ► Add Attribute

 **Command entry:** AEATTRIBUTE

<b>Name</b>	Specifies text used to identify the attribute (attribute tag).
<b>Value</b>	Specifies the attribute text. This value is displayed on the drawing and used in reports. <hr/> <b>NOTE</b> It can be left blank. <hr/>
<b>Height</b>	Specifies the height for the attribute value.
<b>Justification</b>	Specifies the justification for the attribute value.
<b>Invisible</b>	Indicates whether the attribute is visible on the drawing.

## Set tags to fixed

### Set component tags to fixed

#### Fix selected tags

**NOTE** To unfix a component tag, in the Fixed/Unfixed Component Tag Marking dialog box, select Force selected tags to unfixed (normal), click OK, and select the tag to unfix.

- 1 Click Schematic tab ► Edit Components panel ► Edit Components

drop-down ► Fix/Unfix Tag.





- 2 In the Fixed/Unfixed Component Tag Marking dialog box, select whether to force selected tags to fixed or switch a tag between being fixed or unfixed and click OK.
  - **Force selected tags to fixed:** Select the component to fix. Right-click to accept the selection.
  - **Single edit switch fixed/unfixed:** Select the component to fix. In the Fix/Unfix Component Tag dialog box, select Make it Fixed and click OK.

### Fix tags project-wide



- 1 Click Project tab ► Project Tools panel ► Utilities.
- 2 In the Project-Wide Utilities dialog box, Component Tags section, select Set all Parent Component Tags to fixed.  
To unfix tags project-wide, select Set all Parent Component Tags to normal.
- 3 Click OK.
- 4 In the Batch Process Drawings dialog box, select to process the project, and click OK.
- 5 In the Select Drawings to Process dialog box, select the drawings to process, and click OK.

### Fixed/unfix component tag

Use this tool to mark a component tag as fixed. The tag is unaffected if the drawing is later reprocessed by a Retag command.

 **Ribbon:** Schematic tab ► Edit Components panel ► Edit Components

drop-down ► Fix/Unfix Tag.



 **Toolbar:** Edit Component

 **Menu:** Components ► Component Tagging ► Fix/UnFix Component Tag

 **Command entry:** AEFIXTAG

Select whether to force selected tags to fixed, force selected tags to unfixed, or switch a tag between being fixed or unfixed.

AutoCAD Electrical changes the attribute of the component to a fixed layer as defined in the Define Layers dialog box.

## Retag components

Retag recalculates each selected primary component tag, and updates the related components. You can update a single component, a group of components, a drawing, drawings within your project, or the entire project.

Run Retag Components when something changes on your drawing or project that affects the component tags. It can include revising the ladder line reference numbers or changing the tag format. Retag recalculates each selected primary component tag, and then updates the related components. The Tag format is set up on the Drawing Properties ► Components dialog box.

The introduction of one-line components has added an additional type of primary component. Within a project you can represent a component with both a schematic parent symbol and a one-line parent symbol. These are considered peer components. The retag function uses the following rules when retagging these peer components:

- If you retag a schematic parent, the tag value of the one-line parent is updated to match.
- If you retag a one-line parent, the tag value of the schematic parent is updated to match.
- If you run a project-wide retag, the first one encountered gets retagged and the peer is updated to match.
- If you run a project-wide retag and either the schematic parent tag or the one-line parent tag is fixed, the components are not retagged.

---

**NOTE** All one-line components are identified by a WDTYPE "1-" attribute value.

---

### Retag components

Retags single, windowed, drawing wide, and project-wide components with contact updates.

**Ribbon:** Schematic tab ► Edit Components panel ► Retag Components

drop-down ► Retag Components.

**Toolbar:** Main Electrical

**Menu:** Components ► Component Tagging ► Retag Components

**Command entry:** AERETAG

Retag recalculates each selected primary component tag, and updates the related components. You can update a single component, a group of components, a drawing, drawings within your project, or the entire project.

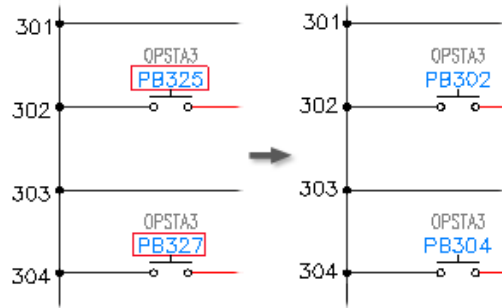

## Change to multi-line text

### Convert text to a multi-line text entity

This tool converts a long string of relay coil or source/destination cross-reference text to a multiline text entity (MTEXT). The underlying attribute value is maintained, but flipped to visible. The MTEXT entity is created at the same XY location as the underlying attribute. The MTEXT entity updates, scoots, and behaves as if it is an attribute tied to the component block.

- 1 Click Schematic tab ► Edit Components panel ► Modify Component Cross-Reference drop-down ► Change Cross-Reference to Multiple Line



Text.

- 2 Select the text string to change.
- 3 Type a new text string for the selected text.  
Use the Text Formatting dialog box to change the text style and size. You can also right-click and select from the context menu options.
- 4 Use the grips or double-click the text to bring up text formatting options to reformat the reference string into multiple lines.
- 5 Click OK.

## Add location codes

### Add location codes to components

You can add Location codes to components after they were created or you can set a default Location code to use for all components that are inserted into a drawing.

#### Add Location codes on a per-drawing basis

First, set your project to use automatic fill for Location values, and then set the default for the drawing. You have a default Location value for each new component that you insert (whether field or panel) on the same drawing.

- 1 Click Project tab ► Project Tools panel ► Manager. 
- 2 In the Project Manager, right-click the project name, and select Properties.
- 3 In the Project Properties ► Components dialog box, Component TAG Options section, select Upon insert: automatic fill Installation/Location with drawing default or last used. Click OK.
- 4 Open the drawing to set the default location value for.
- 5 Click Schematic tab ► Other Tools panel ► Drawing Properties

drop-down ► Drawing Properties. 

- 6 In the Drawing Properties ► Drawing Settings dialog box, IEC - Style Designators section, enter a default Location value. Click OK.

---

**TIP** You can click Drawing or Project to select a Location value that was already in either the active drawing or project.

---

The next time you insert a new component on this drawing, the Location code are prefilled with the drawing default.

### Add a Location code to a saved component

- 1 Open a .dwg file of the saved symbol in AutoCAD.
- 2 Use the ATTDEF command to add the new attribute or copy an attribute definition and rename it.
- 3 Save the drawing file.

The symbol now contains an AutoCAD Electrical Location value attribute.

## Update child codes

### Update child location codes

A child contact should carry the same location code that is present on its parent component. If relay coil CR101 is marked "PNL1," then all CR101 contacts should also carry this location code. In addition, if a child component carries MFG and CAT attributes, they should carry the same information as the parent.

- 1 Click Schematic tab ► Edit Components panel ► Modify Component Cross-Reference drop-down ► Child Location/Description Update.



- 2 Select the values to match to those values carried on the schematic parent component.
- 3 Click OK.
- 4 Select the components to update in your drawing and right-click or type "ALL" to process the entire drawing.

AutoCAD Electrical quickly extracts a listing of all parent components and pertinent codes from all drawings listed in the current project and applies them to the child contacts you selected on the active drawing.

## Child contact and panel update from schematic parent

This tool updates child and panel components with installation, location, and description values carried by the associated parent schematic component.

 **Ribbon:** Schematic tab ► Edit Components panel ► Modify Component



Cross-Reference drop-down ► Child Location/Description Update.



 **Toolbar:** Cross-Reference

 **Menu:** Components ► Cross-Reference ► Child Location/Description Update

 **Command entry:** AECHILDLOCUPDATE

### Installation/Location Attributes

<b>Installation codes</b>	Specifies to update the child and panel components with the parent installation code.
<b>Location codes</b>	Specifies to update the child and panel components with the parent location code.
<b>Description text</b>	Specifies to update the child and panel components with the parent description text.
<b>Description to always match parent</b>	Specifies that the description should always match the parent description text.
<b>Description update only if child blank</b>	Specifies that the description should only be updated to match the parent description text if the child description values are blank.
<b>Rating values</b>	Specifies to update the child and panel components with the parent rating values.

### Manufacturer/Catalog part number values

<b>Manufacturer/Catalog part number values</b>	Specifies to update the child and panel components with the parent Manufacturer/Catalog part number values.
--	---

Manufacturer/Catalog to always match schematic parent	Specifies that the Manufacturer/Catalog should always match the parent Manufacturer/Catalog values.
Manufacturer/Catalog update only if child is blank	Specifies that the Manufacturer/Catalog should only be updated to match the parent Manufacturer/Catalog text if the child Manufacturer/Catalog values are blank.

---

**NOTE** If you choose to update the Manufacturer/Catalog, it does not carry to the children unless they carry the Manufacturer and Catalog attributes.

---

## Location Mark Symbols

### Substitute location mark symbols for text location codes

#### Substitute location mark symbols for text location codes

You can insert location marks on symbols that are identified with location code in text form.

#### Add a location code to a component

If you try to insert a location mark symbol on a component with a blank location code, you are prompted to enter the location code before selecting a marker. Once you insert a location code, a location mark symbol can be associated to it and the component.

- 1 Click Schematic tab ► Insert Components panel ► Location Box

drop-down ► Location Symbols.



- 2 Select a component to add the symbol to and press Enter.  
If a location code is not associated to the component, the Add Location to Component dialog box displays.
- 3 Specify the location code by typing it, clicking component that carries the location value, or by selecting from a list of location codes used on the drawing or in the project.

- 4 Click OK.

### Insert a location mark symbol

- 1 Click Schematic tab ► Insert Components panel ► Location Box



- 2 Select a component to add the symbol to and press Enter.
- 3 From the Location Symbols dialog box, select the symbol to associate with the component and click OK.  
The attribute text becomes invisible and the location symbol inserts at its location.

You can reposition the location marks with the AutoCAD Move command. If you scoot the symbol, the mark moves with it.

---

**NOTE** You cannot assign the same mark to two different locations.

---

### Remove a location mark symbol

- 1 Click Schematic tab ► Insert Components panel ► Location Box



- 2 Select a component to remove the symbol from and press Enter.  
The location mark symbols are removed and the original location attribute is visible again.

### Add a new symbol to the menu

The Location Symbols menu is driven by a text file (wd\_locs.dat) that you can modify.

- 1 Create the mark symbol, save it to  
**Windows XP:** \Documents and Settings\All Users\Documents\Autodesk\Acade {version}\Libs\{library}\  
**Windows Vista, Windows 7:** \Users\Public\Documents\Autodesk\Acade {version}\Libs\{library}\



with a file name that begins with "WDXX" (for example, "WDXXSQ1.DWG")

Create an AutoCAD slide of the symbol and save the resulting .sld file.

2 Open the drawing in AutoCAD and center it on the screen.

3 Type MSLIDE at the command prompt.

4 Enter

**Windows XP:** \Documents and Settings\{username}\Application Data\Autodesk\AutoCAD Electrical {version}\wdxxsq1.sld

**Windows Vista, Windows 7:**

\Users\{username}\AppData\Roaming\Autodesk\AutoCAD Electrical {version}\wdxxsq1.sld

as the file name to create.

5 Click Save.

6 Make a backup copy of

**Windows XP:** \Documents and Settings\{username}\Application Data\Autodesk\AutoCAD Electrical {version}\{release}\{country code}\Support\wd\_locs.dat

**Windows Vista, Windows 7:**

Users\{username}\AppData\Roaming\Autodesk\AutoCAD Electrical {version}\{release}\{country code}\Support\wd\_locs.dat

7 Edit wd\_locs.dat with a text file editor (such as WordPad).

8 Add the reference to the new mark symbol (for example, "Special Square | WDXXSQ1.SLD | WDXXSQ1").

---

**NOTE** You can also do this using the AutoCAD Electrical Icon Menu Wizard.

---

## Location symbols

Location mark symbols are block inserts with block names that begin with "WDXX". Default symbols are included in the AutoCAD Electrical symbol library (ex: in JIC1 subdirectory). You can edit the symbol appearance by just calling up in AutoCAD and modifying to suit. You can substitute "smart" geometric symbols for text "location" code values. The location text is hidden and replaced by a geometric shape. They are smart in that they update if the underlying component location code changes.

 **Ribbon:** Schematic tab ► Insert Components panel ► Location Box

drop-down ► Location Symbols.



 **Toolbar:** Main Electrical 2

 **Menu:** Components ► Component Tagging ► Location Symbols

 **Command entry:** AELOCATIONSYMBOL

Select a component to add the symbol to and press Enter.

Some location symbol options include: Filled Triangle, Filled Square, Filled Diamond, Filled Circle, 1/2 Filled Triangle, 1/2 Filled Square, 1/2 Filled Diamond, and 1/2 Filled Circle.

### Adding custom symbols to menu

You can create additional symbols if you wish. Follow the WDXX... naming convention and add to the icon menu as illustrated in the following section. The icon menu is driven by an ASCII text file, wd\_locs.dat. Edit this file to add references for your own location mark symbols. You can also add additional submenu pages to the menu in a manner like that of the Insert Component icon menu file.

Example WD\_LOCS.DAT file with user-added submenus 100 and 101:

```
**M0
L4
L O C A T I O N S Y M B O L S
Filled Triangle | loc2(s_wdxxt) | wdxxt
Filled Square | loc2(s_wdxxs) | wdxxs
Filled Diamond | loc2(s_wdxxd) | wdxxd
Filled Circle | loc2(s_wdxxc) | wdxxc
Remote station syms | remote.sld | $$=M100
Customer symbols | cust.sld | $$=M101
**M100
L4W
```

## REMOTE STATION SYMBOLS

Main Operator sta | wdx\_x\_mos | wdx\_x\_mos

Wash-down sta | wdx\_x\_wds | wdx\_x\_wds

\*\*M101

L2

## CUSTOMER SYMBOLS

Customer power | wdx\_x\_cp | wdx\_x\_cp

Customer furnished | wdx\_x\_cf | wdx\_x\_cf

---

**NOTE** You only need to define the L\*W row if you plan on using this .dat file in a version of AutoCAD Electrical before AutoCAD Electrical 2008.

---

## Location box

A location box is drawn around devices to designate that they are physically in a different location/installation than the other devices in the drawing. The box is a closed polyline and can be a rectangle or some other orthogonal shape.

The Location and installation codes for the parent components within the location box update to match the location box. You can assign a description to the box. The program prompts for updates to related components and panel footprints.

AutoCAD Electrical commands are location box aware:

- Inserting or moving a component into a location box updates the location and installation values of the component.
- Moving a component out of a location box prompts the option to update the location and installation values of the component to match the drawing values.
- The insertion point of a component determines whether it is considered inside or outside a location box.

AutoCAD Electrical circuit commands are not location box aware. For example, if a circuit is inserted and some of the components fall within a location box, the components are not updated.

---

**NOTE** Using standard AutoCAD commands do not trigger any updates.

---

The layer assigned to the Location Box feature determines the color and linetype of the polyline. Assign the layer on the [Drawing properties: drawing format tab](#) on page 231 dialog box.

## Insert Location Box

Inserts a location box around one or more components. You have the option to update the location and installation codes for the parent components within the box to match the location box. You can assign a description to the location box.

- 1 Click Schematic tab ► Insert Components panel ► Location Box



drop-down ► Location Box.

- 2 To insert a rectangular box, respond to the prompts as follows:

Specify first corner point or (9=orthogonal shape):

*Select a location for the first corner of the rectangle*

Specify second point:

*Select a location for the second corner of the rectangle*

- 3 To insert an orthogonal shape, respond to the prompts as follows:

Specify first corner point or (9=orthogonal shape):

Press 9 ENTER

Specify starting corner:

*Select a location for the first corner of the shape*

Select next corner:

*Select a location for the next corner of the shape*

Continue selecting locations until ready to close the shape.

Press C ENTER

Specify description insertion point:

*Select a location for the description text for the location box.*

The Location Box dialog box displays.

- 4 Enter the Location value for the box.
  - **Browse** - displays the Location Codes dialog box where you can select a location code used in the project, on the active drawing, or from an external .LOC file.

- **Pick “Like”** - temporarily exits the Location Box dialog box so you can select an existing location code value on the drawing.
- 5 Enter the Installation value for the box.
    - **Browse** - displays the Installation Codes dialog box where you can select an installation code used in the project, on the active drawing, or from an external .INST file.
    - **Pick “Like”** - temporarily exits the Location Box dialog box so you can select an existing installation code value on the drawing.
  - 6 Select whether to update the location and installation values of the parent components within the box to match the values of the location box.
  - 7 Select the visibility for the location and installation attributes of all components within the box.
  - 8 Define the optional description text for the location box.
    - **Text Height** - enter the height or select the Pick Height button to select a text object on the drawing with the desired height.
    - **Description Insertion Point** - change the location for the description text. If the box is not a rectangle, this button is disabled.
    - **Box description** - enter the description value.
    - **Use =Installation+Location Values** - enter a predefined value based on the location box values.
    - **Use Location-Installation Values** - enter a predefined value based on the location box values.
    - **Drawing** - displays the All Location Box Descriptions - Drawing dialog box. Select a description from the list.
    - **Pick “Like”** - temporarily exits the Location Box dialog box so you can select an existing description value on the drawing.
  - 9 Click OK.

---

**NOTE** Use the Edit Component command to edit a location box.

---

## **Location box**

Inserts a location box around one or more components.

 **Ribbon:** Schematic tab ► Insert Components panel ► Location Box

drop-down ► Location Box.



 **Toolbar:** Location Symbols



 **Menu:** Components ► Component Tagging ► Location Box

 **Command entry:** AELOCATIONBOX

You have the option to update the location and installation codes for the parent components within the box to match the location box. You can assign a description to the box.

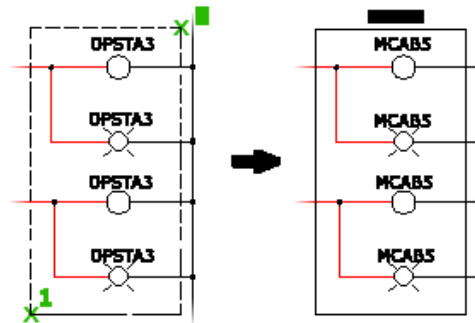

### Installation/Location Codes

#### Location

Specifies the location code.

- **Browse** - displays the Location Codes dialog box where you can select a location code used in the project, on the active drawing, or from an external .LOC file.
- **Pick "Like"** - temporarily exits the Location Box dialog box so you can select an existing location code value on the drawing.

#### Installation

Specifies the installation code.

- **Browse** - displays the Installation Codes dialog box where you can select an installation code used in the project, on the active drawing, or from an external .INST file.

- **Pick “Like”** - temporarily exits the Location Box dialog box so you can select an existing installation code value on the drawing.

**Update existing parent symbols values to match the location box**

By default, all location and installation values on schematic parent symbols inside the location box, update to match the values of the location box. Uncheck this option to keep the values on the symbols.

**Force Installation and Location attributes to be visible or invisible**

By default, location and installation values on all symbols are made invisible.

- Uncheck so no visibility changes are made.
- If checked, select to set the visibility for the location and installation attributes.

**Dashed Box Information**

**Text Height**

Specifies the description height. Description height can be entered in the edit box or picked from an existing device from the active drawing.

**Box Description**

Specifies the description text.

**Description Insert Point**

Specifies the description insertion point: top, bottom, left or right. Enter a description to enable the button.

---

**NOTE** If the location box is not a rectangle, this button is disabled.

---

**Use =Installation+Location Values**

Enters ={installation value}+{location value} as the box description.

**Use Location-Installation Values**

Enters {location value}-{installation value} as the box description.

**Drawing**

Searches the active drawing for location box descriptions. Displays the list in the All Location Box Descriptions - Drawing dialog box. Select a description from the list.

Pick "Like"

Picks a description from a component in the active drawing.

---

**NOTE** Use the AutoCAD Electrical Edit Component to change the Location Box values.

---

## Modify library symbols

### Change library symbol attribute size

Use the Modify Symbol Library tool to change the attribute description size for library symbols.

---

**NOTE** Make a backup copy of the library you plan to modify (such **Windows XP:** `\Documents and Settings\All Users\Documents\Autodesk\Acade {version}\libs\jic1` library, or **Windows Vista, Windows 7:** `\Users\Public\Documents\Autodesk\Acade {version}\libs\jic1` ). If the conversion does not give you the results you expect you can restore the symbols, adjust the settings, and then rerun.

---

- 1 Click Schematic tab ► Other Tools panel ► Symbol Builder drop-down ►



Modify Symbol Library.

- 2 Select the folder containing the library symbols you wish to convert and press OK.

The Symbol Library Attribute Text/Scale Resize dialog box displays. You can change the attribute size based on the AutoCAD Electrical attribute type.

- 3 Select the attributes to change. Notice that you can change the attributes for parent/stand-alone symbols separate from the child/contact symbols.
- 4 Enter the new value and click Start.

The first library symbol is immediately opened. Changes are made to the selected attributes. The drawing is saved, and the operation moves on to the next symbol. It continues until each symbol is updated.

---

**NOTE** You can also use this tool to change the default text width or the text font used for the text style of AutoCAD Electrical.

---



## Symbol library attribute text/scale resize

 **Ribbon:** Schematic tab ► Other Tools panel ► Symbol Builder



drop-down ► Modify Symbol Library.

 **Menu:** Components ► Symbol Library ► Modify Symbol Library

 **Command entry:** AEUPDATESYMLIB

Select the folder and click OK.

<b>Re-scale symbol</b>	Specifies the new scale for the symbol. A value of 1.0 = no change.
<b>Change polyline width</b>	Specifies the new polyline width for the symbol. It is useful when modifying the polyline width for the one-line library symbols but works on any symbol with polylines.
<b>Run AutoLISP "(command...)" expression</b>	Specifies which command to run using the built-in AutoLISP programming in AutoCAD Electrical. Enter the AutoLISP code in the edit box.
<b>Force attributes to fixed text width</b>	Specifies the new width for the attribute text.
<b>Change "WD" style</b>	Specifies the default text width and font used for the text style in AutoCAD Electrical. Choose the desired style from the list.
<b>Do a save even if no change</b>	Specifies to perform a save even if you did not modify the symbol library.
<b>Force attributes to fixed text heights</b>	Specifies the text height for the following attributes: parent or child components, installation and location codes, position, state, component terminal pins, parent and child descriptions and cross-references.



# Wire/Wire Number Tools

# 12

## Overview of wires

AutoCAD Electrical treats line entities as wires when the lines are found on an AutoCAD Electrical-defined wire layer. You can have many wire layers set up on your drawing. Each wire layer has a descriptive name like "RED\_16" or "BLK\_14\_THW" and is assigned a screen color to mimic the wire color visually. Wires do not have to begin or end at snap points, and they do not have to be orthogonal (they can be skewed at any angle).

A wire network is one or more wire line segments and optional branches that interconnect and form an electrically unbroken conductor. Wire segments of the network may contain in-line terminals and wire crossing gaps. All segments of a wire network receive the same wire number unless you select On per Wire Basis in the Wire Number Options section of the Project Properties ► Wire Numbers dialog box (on the Project Manager, right-click the project name and select Properties). When multiple wires are tied to a common wire connection point, each wire is treated as an independent wire network and receives its own unique wire number assignment by AutoCAD Electrical

---

**NOTE** A wire connection point should only have up to three wire connections tied to it. Adding more wires to a single point prevents the angled wire connection to tie uniquely to the wire connection point.

---

## Use wire layers

The Set Wire Type tool is used for setting a wire type for new wires only. The wire layer name and the associated wire properties (such as wire color, size, and

whether the wire layer is processed for wire numbers) are saved in the drawing file. The following rules determine the wire layer for a new wire:

- When a wire is created from an existing wire, the new wire takes on the same layer as the existing wire. It ignores the current layer and the current wire type.
- When the new wire is started in empty space but ends at an existing wire, the new wire takes on the wire layer of the ending wire. The current layer and current wire type are ignored.
- When a new wire is started at an existing wire and ends at another existing wire, the new wire takes on the layer of the beginning wire.
- If there are no wire layers in the drawing, the new wire is drawn in the WIRES layer.
- When a wire starts in empty space and ends at the component wire connection point, the new wire is drawn on the current wire type. The layer of the wires already tied to the same component connection points are ignored. The same is true for a wire that starts at the component wire connection point and ends in empty space.

Use the Create/Edit Wire Type tool to create new or edit existing wire types or use the Change/Convert Wire Type tool to convert lines to wires.

## Create wire types

Wire types for drawings are set up in the Create/Edit Wire Type dialog box.

- 1 Click Schematic tab ► Edit Wires/Wire Numbers panel ► Modify Wire



Type drop-down ► Create/Edit Wire Type.

- 2 In the Create/Edit Wire Type dialog box, click inside the Wire Color column for a blank row and specify a value for the new wire layer.
- 3 Click inside the Size column and specify a value for the size.  
The Layer Name is automatically created. If you specified Wire Color: Red and Size: 20, the name RED\_20 is assigned to the wire layer you are creating.
- 4 If you do not want wires on this layer processed for wire numbers, select No for the Wire Numbering option.

- 5 To import wire types from an existing drawing or template, click Import.
  - Select the drawing or drawing template containing the wire types for import.
  - On the Import Wire Types dialog box, select the wire types for import.
  - Define how the import function behaves if a wire type exists on the active drawing.
- 6 Click Color, Linetype, or Lineweight to assign values for the new layer.

---

**NOTE** If you want the new wire layer to be the default, click Mark Selected as Default.

---

- 7 Click OK.

## Add existing wire layers to the drawing

Wire layer names for drawings are set up in the Create/Edit Wire Type dialog box.

- 1 Click Schematic tab ► Edit Wires/Wire Numbers panel ► Modify Wire



Type drop-down ► Create/Edit Wire Type.

- 2 In the Create/Edit Wire Type dialog box, click Add Existing Layer.
- 3 In the Layers for Line "Wires" dialog box, define the layer name and click OK. You can either enter a name in the edit box or click Pick to select a name from the existing layer list.

The layer displays in the wire type grid. If you selected the wrong wire layer, highlight the layer in the dialog box and click Remove Layer. You can then go back into the Layers for Line "Wires" dialog box and select another layer to add.
- 4 In the Create/Edit dialog box, click Color, Linetype, or Lineweight to assign new values for the layer.
- 5 If you do not want wires on this layer processed for wire numbers, select No for the Wire Numbering option.
- 6 Click OK.

## Create/edit wire type

Defines and edits wire types.

 **Ribbon:** Schematic tab ► Edit Wires/Wire Numbers panel ► Modify

Wire Type drop-down ► Create/Edit Wire Type.

 **Toolbar:** Wires

 **Menu:** Wires ► Create/Edit Wire Type

 **Command entry:** AEWIRETYPE

The program saves the wire layer name and associated properties, such as wire color, size, and whether the wire layer is processed for wire numbers, in the drawing file. Use the grid control to sort and select wire types to modify.

---

**TIP** Use the Change/Convert Wire Type tool to convert lines to wires. You can also type "T" at the command prompt during wire insertion to use the Set Wire Type tool.

---

### Wire type grid

Displays the wire types used in the active drawing. The wire layer name and the wire properties like color, size, whether the wire layer is processed for wire numbers, and user-defined properties are listed in the grid. An "x" in the Used column indicates that the layer name is currently used in the drawing. A blank value in this column indicates that the layer name exists in the drawing but it is not currently being used. The current wire type is highlighted with a gray background; selected wire types highlight in blue.

If you do not want wire numbers assigned to wires on a specific layer, select "No" Wire Numbering for that layer. The Insert Wire Numbers command follows these rules:

- If **all** wires in the network are on layers set "No" for Wire Numbering, no new wire number is inserted.
- If **any** wire in the network is on a layer set "Yes" for Wire Numbering, the existing non-fixed wire number is updated or a new wire number is inserted.
- If a wire network already has a non-fixed wire number, it is updated regardless of the Wire Numbering setting. Use the Delete Wire Numbers command to remove the wire number.

---

**NOTE** Manually maintain wire layer type consistency through signal arrows.

---

To rename the User1- User 20 column headers, right-click the project name in the Project Manager and select Properties. In the Project Properties ► Wire Numbers dialog box, Wire Type section, click Rename User Columns. In the Rename User Columns dialog box, specify a new column name and click OK. Renaming of user-defined columns is project-specific. You cannot rename the Color, Size, or Layer Name columns. All the data corresponding to the header column can be copied, cut, and pasted to another column.

All text fields are editable except for the Layer Name cell. It cannot be edited for existing layers. Left-click to edit the cell or right-click in a cell to display options for modifying the cell contents. If you want to rename a layer, right-click on a cell and select Rename Layer. Right-click options include: Copy, Cut, Paste, Delete Layer, and Rename Layer. If it is the default layer, you cannot delete or remove the layer.

You can select multiple layers to edit or remove by using the Shift or Ctrl keys on your keyboard while picking the wire layer in the wire type list.

You can move the wire type records inside the grid to whatever position you want using drag and drop. Select the wire type records to move and drag to the new position in the grid.

### Option

#### Make All Lines Valid Wires

Makes all existing layers valid wire layers and displays them in the wire type grid.

If you later decide you want some layers to be wire layers and others to be line layers, you can deselect this option. All the layers are removed from the wire type grid. Add layers again using the Add Existing Layer option.

#### Import

Imports wire types from an existing drawing or drawing template. Once the drawing is specified, the [Import Wire Types](#) on page 903 dialog box displays. Select the wire types to import.

## Layer

Allows you to format the layer name, define or edit the layer color, linetype, and line weight.

<b>Layer Name Format</b>	<p>Format the layer name. The program fills the layer name automatically once you enter a value in color, size based on the format. For example, if you enter BLK for color and 10AWG for size, the layer name is filled in as BLK_10AWG based on default %C_%S format. Placeholders are supported at any place in the format (that is, "CUST%C-THIN%S).</p> <p>Valid wire name format codes are:</p> <ul style="list-style-type: none"><li>■ %C = Wire Color</li><li>■ %S = Wire Size</li><li>■ %1-%5 = User 1 - User 5</li></ul>
<b>Color</b>	<p>Displays the AutoCAD dialog box for Layer colors election. The Select Color dialog box highlights the color corresponding to the wire type record. The default color for new records is white. Undefined colors for layers use the default color while creating the layer. Multiple selection is allowed. All wire layers that were selected can be changed to the color.</p>
<b>Linetype</b>	<p>Displays the AutoCAD dialog box for linetype selection. This Select Linetype dialog box highlights the linetype corresponding to the wire type record. The default linetype for new records is continuous. Undefined linetypes for layers use the default linetype while creating the layer. Multiple selection is allowed. All wire layers that were selected can be changed to the desired linetype.</p> <hr/> <p><b>NOTE</b> If you need special linetypes for constructing P&amp;ID or point to point diagrams, load the special linetypes from theacad.lin text file.</p> <hr/>
<b>Lineweight</b>	<p>Displays the AutoCAD dialog box for lineweight selection. The Lineweight dialog box highlights the lineweight corresponding to the wire type record. The default lineweight for new records is default. Undefined lineweights for layers use the default</p>



lineweight while creating the layer. Multiple selection is allowed. All wire layers that were selected can be changed to the desired lineweight.

#### Add Existing Layer

Displays the Layers for Line Wires dialog box for specifying a layer name. Click Pick to select the layer name from the existing layer list consisting of all the layers in the drawing inclusive of the non-wire layers. Only lines on pre-selected layers are processed as wires. Enter a wire layer name in the dialog box. A wildcard used in the name selects a group of layers (for example, RED\_\* selects all layers that begin with "RED\_").

#### Remove Layer

Removes the selected layer name from the wire type grid. The layer is no longer a valid wire layer, however the layer remains in the drawing as an AutoCAD line layer.

If multiple layers of one color exist in the drawing, select all layers of that color in the wire type grid to activate this button. For example, if there are multiple RED\* layers such as RED\_AWG18, RED\_AWG20, and RED\_AWG25, select all three layers in the wire type grid to enable the button.

---

**NOTE** You cannot remove the wire layer marked as the default.

---

#### Mark Selected as Default

Makes the selected layer the default layer for new wire layers and displays the layer name in the dialog box.

#### OK

---

**NOTE** This option is available only when one wire type record is selected in the list.

---

Makes the selected wire type the current wire type. If the selected wire type does not exist on the drawing, the wire layer is created on the fly. The wire layer name and properties are saved in the drawing file. For the layer to create, the following rules apply:

- The layer name must be unique

- The layer name cannot be left blank
- The layer name cannot contain special characters such as / \ " ; ? \* | , = ' > <

## Import wire types

- 1 Click Schematic tab ► Edit Wires/Wire Numbers panel ► Modify Wire



Type drop-down ► Create/Edit Wire Type.

- 2 Click Import.  
The Wire Type Import - Select Master Drawing dialog box displays.
- 3 Select the drawing or drawing template containing the wire types for import.
- 4 Click Open.  
The Import Wire Types dialog box displays.
- 5 Select the wire types for import.
- 6 Define how the import function behaves if a wire type exists on the active drawing.
  - Overwrite any Wire Numbering and USERn differences** - if checked, changes the wire numbering setting and all the USER values for the existing wire type to match the imported wire type.
  - Update any layer color and linetype differences** - if checked, changes the color and linetype settings for the existing wire layer to match the imported wire layer.
- 7 Click OK.  
The selected wire types and settings display in the Create/Edit Wire Type dialog.
- 8 Continue adding, importing, and editing wire types in the Create/Edit Wire Type dialog.
- 9 Click OK.

## Import wire types project-wide



- 1 Click Project tab ► Project Tools panel ► Utilities.
- 2 Select the Import from specified drawing check box.
- 3 Browse to or enter the name of the drawing or drawing template containing the wire type definitions for import.
- 4 Click Setup to display the Import Wire Types dialog box.
- 5 Select the wire types for import.
- 6 Define how the import function behaves if a wire type exists on the drawing being processed.
  - Overwrite any Wire Numbering and USERn differences** - if checked, changes the wire numbering setting and all the USER values for the existing wire type to match the imported wire type.
  - Update any layer color and linetype differences** - if checked, changes the color and linetype settings for the existing wire layer to match the imported wire layer.
- 7 Click OK and return to the Project-Wide Utilities dialog box.
- 8 Click OK.
  - The Select Drawings to Process dialog box displays.
- 9 Select the drawings you want to import the selected wire types into.
- 10 Click OK.

## Import Wire Types

Imports wire types from another drawing or drawing template.



### Create/Edit Wire Type

 **Ribbon:** Schematic tab ► Edit Wires/Wire Numbers panel ► Modify



Wire Type drop-down ► Create/Edit Wire Type.



-  **Toolbar:** Wires
-  **Menu:** Wires ► Create/Edit Wire Type
-  **Command entry:** AEWIRETYPE



Click the Import button in the Option section.

### Project-wide utilities



-  **Ribbon:** Project tab ► Project Tools panel ► Utilities.



-  **Toolbar:** Project
-  **Menu:** Projects ► Project-Wide Utilities
-  **Command entry:** AEUTILITIES

Select the Import from specified drawing check box. Browse to or enter the name of the drawing or drawing template containing the wire type definitions for import. Click Setup.

Double click a column heading to sort the wire type list by the data in that column.

<b>Grid</b>	Select the wire types to import.
<b>Clear All Select All</b>	All wire types are initially selected to import. Clears or selects all wire types to import. <hr/> <b>NOTE</b> The button switches between Select All and Clear All each time it is clicked. <hr/>
<b>Overwrite any Wire Numbering and USERn differences</b>	If checked, changes the wire numbering setting and all the USER values for the existing wire type to match the imported wire type.
<b>Update any layer color and linetype differences</b>	If checked, changes the color and linetype settings for the existing wire layer to match the imported wire layer.

### Project-wide utilities

Provides the means for operations on wire numbers, component tags, attribute text, wire types, and item numbers. You can define scripts and apply them project-wide.

 **Ribbon:** Project tab ► Project Tools panel ► Utilities.



 **Toolbar:** Project



 **Menu:** Projects ► Project-Wide Utilities

 **Command entry:** AEUTILITIES

Select project drawings and perform any of the following:

- Erase, reset, fix, or unfix wire numbers.
- Fix or unfix component tags.
- Fix or unfix item numbers.
- Clear signal cross-referencing.
- Run a user-specified script file.
- Change attribute text size or style.
- Import wire types from another drawing or drawing template.

You can have multiple drawings open at any time. However, to maximize performance and memory usage, minimize the number of open drawings when running project-wide commands.

### Wire Numbers

Select to keep wire numbers the same, erase specified wire numbers, reset specified wire numbers, or set wire numbers to fixed or normal.

### Signal Arrow Cross-reference text

Select to maintain the signal arrow cross-reference text or to remove all signal arrow cross-reference text across the current project.

### Parent Component Tags: Fix/Unfix

Select to maintain the component tags or to set all parent component tags to fixed or normal across the current project.

### Item Numbers: Fix/Unfix

Select to maintain the item numbers or to set all item numbers to fixed or normal across the current project. If you run [Resequence Item Numbers](#) on page 1602 later on, fixed item numbers do not change.

### Change Attribute

#### Change Attribute Size

Click Setup to select the attributes to change, and then enter the height and width definitions for the selected attributes.

---

**NOTE** If you do not want the attribute height or width to change, do not enter a value definition.

---

#### Change Style

Click Setup to select a text font to apply to the text style used on component attributes.

### For each drawing

Enter the name or browse to a command script file to use for each drawing in the current project or to purge all blocks.

### Wire Types

Imports wire types defined on another drawing or drawing template. Enter the drawing or template name or browse to it using the browse button. The program reads the specified drawing and extracts all wire type information. Click Setup to display the [Import Wire Types](#) on page 903 dialog box where you:

- Select the wire types to import.
- Define whether to overwrite any Wire Numbering and USERn differences for existing wire types.
- Define whether to overwrite color and linetype differences for existing wire layers.

# Change wire types

## Change wire types

You can change the wire type using the Change/Convert Wire Type tool or by typing a "T" at the command prompt during wire insertion commands.

- 1 Click Schematic tab ► Edit Wires/Wire Numbers panel ► Modify Wire



Type drop-down ► Change/Convert Wire Type.

Optionally, you can right-click on an existing wire and select Change/Convert Wire Type.

- 2 In the Change/Convert Wire Type dialog box, select a wire type record in the wire type list, or click Pick to select a wire type record from the drawing.

If you right-clicked on a wire and selected Change/Convert Wire Type, the wire type corresponding to the selected wire layer is highlighted in the list.

- 3 Make any selections in the dialog box.

If Change all wires in the wire network is selected, all wires in the wire network are changed to the new wire type. If unselected, only the selected wire is changed.

If Convert Lines to Wires is selected, the selected lines are changed to the new wire type. If unselected, the lines are ignored.

- 4 Click OK.
- 5 Select the wires or lines in the drawing to change and press Enter.

## Override wire type at command prompt

During wire insertion, the current wire type displays at the command prompt. You can override the wire type by typing in the hot key "T" and selecting a new wire type from the Set Wire Type dialog box. The new wire type becomes the current wire type and the command continues with the wire insertion. Use the following commands:

- Click Schematic tab ► Insert Wires/Wire Numbers panel ► Insert Wires drop-down ► Wire.

- Click Schematic tab ► Insert Wires/Wire Numbers panel ► Insert Wires drop-down ► 22.5 Degree.
- Click Schematic tab ► Insert Wires/Wire Numbers panel ► Insert Wires drop-down ► 45 Degree.
- Click Schematic tab ► Insert Wires/Wire Numbers panel ► Insert Wires drop-down ► 67.5 Degree.
- Click Schematic tab ► Insert Wires/Wire Numbers panel ► Multiple Bus.
- Click Schematic tab ► Edit Wires/Wire Numbers panel ► Modify Ladder drop-down ► Add Rung.
- Click Schematic tab ► Insert Wires/Wire Numbers panel ► Insert Ladder drop-down ► Insert Ladder.

---

**NOTE** If you select Another Bus (Multi-Wire) in the Multiple Wire Bus dialog box, the wires are drawn on the same wire layer as the existing wire bus. You cannot type "T" to change the wire type during wire insertion.

---

## Change/convert wire type

Convert lines to wires, or change wires from one wire type to another.

---

**TIP** Use the Create/Edit Wire Type tool to create and edit wire types. You can also type "T" at the command prompt during wire insertion to use the Set Wire Type tool.

---

 **Ribbon:** Schematic tab ► Edit Wires/Wire Numbers panel ► Modify

Wire Type drop-down ► Change/Convert Wire Type.



 **Toolbar:** Wires

 **Menu:** Wires ► Change/Convert Wire Type

 **Command entry:** AECONVERTWIRETYPE

You can also right-click on an existing wire and select Change/Convert Wire Type. Use the grid control to sort and select the wire types for modification.



### Wire type grid

Displays the wire types used in the active drawing. The wire layer name and the wire properties like color, size, whether the wire layer is processed for wire numbers, and user-defined properties are listed in the grid. An 'x' in the Used column indicates that the layer name is currently used in the drawing. A blank value in this column indicates that the layer name exists in the drawing but it is not currently being used.

A “No” in the Wire Numbering column indicates that wires on this layer do not receive a wire number. The Insert Wire Numbers command follows these rules:

- If **all** wires in the network are on layers set “No” for Wire Numbering, no new wire number is inserted.
- If **any** wire in the network is on a layer set “Yes” for Wire Numbering, the existing non-fixed wire number is updated or a new wire number is inserted.
- If a wire network already has a non-fixed wire number, it is updated regardless of the Wire Numbering setting. Use the Delete Wire Numbers command to remove the wire number.

---

**NOTE** Manually maintain wire layer type consistency through signal arrows.

---

To rename the User1- User 20 column headers, right-click the project name in the Project Manager and select Properties. In the Project Properties ► Wire Numbers dialog box, Wire Type section, click Rename User Columns. In the Rename User Columns dialog box, specify a new column name and click OK. Renaming of user-defined columns is project-specific. You cannot rename the Color, Size, or Layer Name columns. All the data corresponding to the header column can be copied, cut, and pasted to another column.

### Pick

Allows you to pick a wire or line in the active drawing. Once you pick a wire, the corresponding wire type record is highlighted. If you pick a line in the active drawing, you can add the layer where the line resides to the list of valid wire layers. A new wire type record is created automatically.

### Change/Convert

#### Change All Wire(s) in the Network

Changes all the wires in the wire network to the selected wire type record. If unselected, only a single wire is changed to the selected wire type.

### Convert Line(s) to Wire(s)

Changes the lines to the selected wire type in the wire type grid.

#### OK

---

**NOTE** This option is available only when one wire type record is selected in the list.

---

Makes the selected wire type the current wire type. If the selected wire type does not exist on the drawing, the wire layer is created on the fly. The wire layer name and properties are saved in the drawing file. For the layer to create, the following rules apply:

- The layer name must be unique
- The layer name cannot be left blank
- The layer name cannot contain special characters such as / \ " ; ? \* | , = ' > <

Use the grid control to sort and select the wire types for modification.

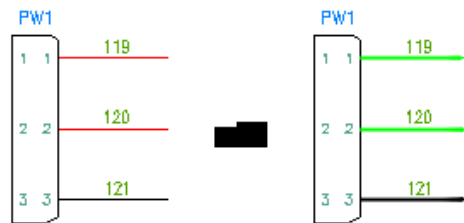

### Set wire type

This tool sets wire types for new wires. Use the grid control to sort and select the wire types for modification.

---

**TIP** Use the Create/Edit Wire Type tool to create and edit wire types or the Change/Convert Wire Type tool to convert lines to wires.

---

Type "T" at the command prompt during wire insertion.

## Wire type grid

Displays the wire types used in the active drawing. The wire layer name and the wire properties like color, size, whether the wire layer is processed for wire numbers, and user-defined properties are listed in the grid. An 'x' in the Used column indicates that the layer name is currently used in the drawing. A blank value in this column indicates that the layer name exists in the drawing but it is not currently being used.

A “No” in the Wire Numbering column indicates that wires on this layer do not receive a wire number. The Insert Wire Numbers command follows these rules:

- If **all** wires in the network are on layers set “No” for Wire Numbering, no new wire number is inserted.
- If **any** wire in the network is on a layer set “Yes” for Wire Numbering, the existing non-fixed wire number is updated or a new wire number is inserted.
- If a wire network already has a non-fixed wire number, it is updated regardless of the Wire Numbering setting. Use the Delete Wire Numbers command to remove the wire number.

---

**NOTE** Manually maintain wire layer type consistency through signal arrows.

---

To rename the User1- User 20 column headers, right-click the project name in the Project Manager and select Properties. In the Project Properties ► Wire Numbers dialog box, Wire Type section, click Rename User Columns. In the Rename User Columns dialog box, specify a new column name and click OK. Renaming of user-defined columns is project-specific. You cannot rename the Color, Size, or Layer Name columns. All the data corresponding to the header column can be copied, cut, and pasted to another column.

## OK

---

**NOTE** This option is available only when one wire type record is selected in the list.

---

Makes the selected wire type the current wire type. If the selected wire type does not exist on the drawing, the wire layer is created on the fly. The wire layer name and properties are saved in the drawing file. For the layer to create, the following rules apply:

- The layer name must be unique.
- The layer name cannot be left blank.

- The layer name cannot contain special characters such as / \ " ; ? \* | , = ' > < .

## Insert wires

### Insert wires

Inserts wire with automatic connection and wire crossing gaps or loops.

- 1 Click Schematic tab ► Insert Wires/Wire Numbers panel ► Insert



Wires drop-down ► Wire.

Click the Insert Wires drop-down to access the Insert 22.5, 45, or 67.5 Degree Wire tools.

- 2 Select the starting point of the wire. You can start a wire segment in empty space, from an existing wire segment, or from an existing component. If you start from a component, the wire segment is started at the nearest wire connection attribute to your pick point on that symbol.

During wire insertion, the current wire type displays at the command prompt.

*T* = override the current wire type. Select a new wire type from the Set/Edit Wire Type dialog box. The new wire type becomes the current wire type and the command continues with the wire insertion.

*X* = show the wire connection points when the wire approaches a component.

*TAB* = temporarily disable or enable collision checking during wire insertion.

This setting is remembered only for the current session. Collision checking is on when AutoCAD Electrical restarts.

*V* = force a vertical direction for the wire segment.

*H* = force a horizontal direction for the wire segment.

*C* = insert the next wire segment at the current cursor location and continue wire insertion.

- 3 Select the ending point of the wire. You can end the wire segment or angled segment in empty space, from an existing wire segment, or from

an existing component. If it ends at a wire segment, a dot (wddot.dwg) is applied, if appropriate. If it ends at another component, the nearest wire connection attribute is found and connected to your pick point on that symbol.

---

**NOTE** If the distance between two horizontal wires is relatively small, the vertical wire crossing them avoids inserting loop gaps. The wire trap distance setting is used to see whether wire loop gaps are possible or not. Reduce the scale factor or increase the distance between two wires to insert gap loops.

---

If the wire was an angled wire, press “N” to switch to normal 90-degree wire mode. The wire picks up at the end of the angled wire segment and defaults to horizontal or vertical.

---

**NOTE** A wire connection point has up to three wire connections tied to it. Adding more wires to a single point prevents the angled wire connection to tie uniquely to the wire connection point.

---

## Insert a wire

Inserts wire with automatic connection and wire crossing gaps or loops.

 **Ribbon:** Schematic tab ► Insert Wires/Wire Numbers panel ► Wire.



 **Toolbar:** Wires

 **Menu:** Wires ► Insert Wire

 **Command entry:** AEWIRE

Inserts a line or series of lines on a defined wire layer in AutoCAD Electrical. A drawing can have multiple wire layers. Wires do not have to begin or end at snap points, and can be at any angle. A wire network is one or more wire segments and optional branches that interconnect and form an electrically unbroken conductor.

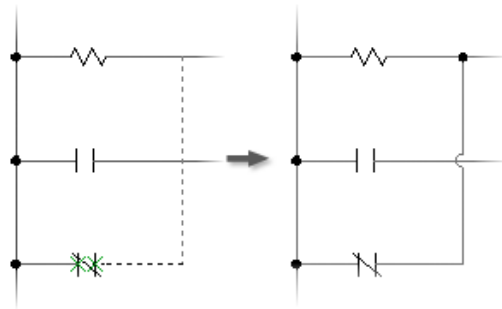

You can insert single or angled (22.5, 45, or 67.5 degree) line wire segments on a wire layer (the wire layer does not have to be the current layer). AutoCAD Electrical supports scooting components along angled wires.

---

**NOTE** The AutoCAD Insert Line command can also be used to insert AutoCAD Electrical wires on a valid wire layer.

---

<b>Wiretype</b>	Displays the Set Wire Type dialog box where you set the wire type for new wires.
<b>Show connections</b>	Shows the wire connection points on a component when the wire is close to the component. The points are shown with temporary graphics.
<b>Start Vertical</b>	Forces the wire in a vertical direction from the previous selection point. This option is available after selecting the first point for the wire.
<b>Start Horizontal</b>	Forces the wire in a horizontal direction from the previous selection point. This option is available after selecting the first point for the wire.
<b>Continue</b>	Inserts the next wire segment at the current cursor location and continues wire insertion.
<b>Collision off</b>	Temporarily disables or enables the collision checking during wire insertion. This setting is remembered only for the current session. Collision checking is on when AutoCAD Electrical restarts. The setting is saved in the global variable <code>GBL_wd_skip_collision_check</code> . A value of 1 indicates to skip

collision checking. A value of nil or 0 means to do collision checking. The default setting is nil.

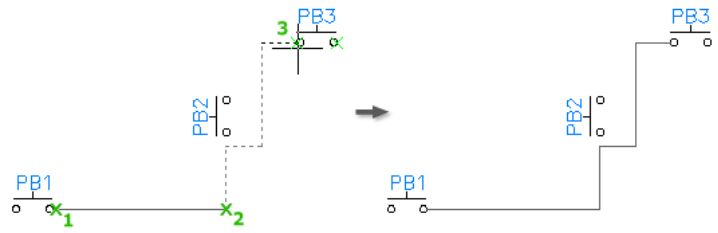

**Collision checking on**

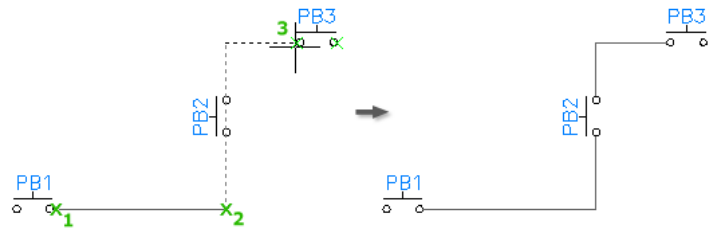

**Collision checking off**

# Insert multiple wires

## Insert multiple wires

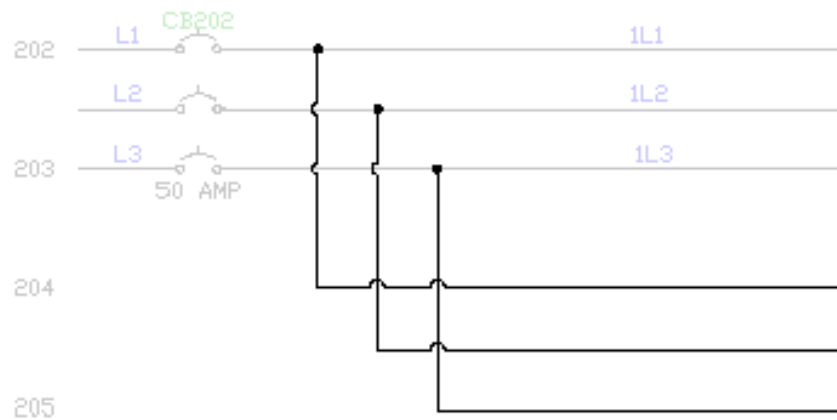

- 1 Click Schematic tab ► Insert Wires/Wire Numbers panel ► Multiple



Bus.

- 2 Set the horizontal and vertical spacing for the wires.
- 3 Specify where to start the wires.
- 4 Set the number of wires to 3, and click OK.  
During wire insertion, the current wire type displays at the command prompt. The current wire type indicates the layer name in which the new wires are drawn. You can override it by typing "T" and selecting a new wire type from the Set/Edit Wire Type dialog box. The new wire type becomes the current wire type and the command continues with the wire insertion.
- 5 If starting at a component or bus, select the component. Drag the cursor slowly to the right as the second and third phases latch on to their appropriate vertical wires. You can see the three wires stretch straight across the screen.



As you pull the 3-phase wire out, you can turn a corner by moving your cursor out of line with the bus. To reverse the phase sequence of the turn, press F.

- 6 Right-click to terminate the wires. The wires and wire connection dots insert, and loops are automatically inserted at wire crossing points.

---

**NOTE** If the distance between two horizontal wires is relatively small, the vertical wire crossing them avoids inserting loop gaps. The wire trap distance setting is used to see whether wire loop gaps are possible or not. Reduce the scale factor or increase the distance between two wires to insert gap loops.

---

To tie the new 3-phase wire to an existing bus, but with reversed sequence, start the new 3-phase wire connected at the last wire on the existing bus. Move the cursor backward across the other wires of the bus. Move the cursor backward across the other wires until the connections are made, and then move the cursor forward again. This results in a reversed sequence connection.

---

**TIP** If you have trouble connecting a new 3-phase wire to an existing bus, start the command and select the starting point on the existing bus. Move the cursor slowly across the other wires of the bus. AutoCAD Electrical has a better chance of finding them and correctly connecting the new wiring.

---

## Multiple wire bus

Inserts a multiple wire bus with automatic connections.

 **Ribbon:** Schematic tab ► Insert Wires/Wire Numbers panel ► Multiple

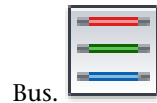

 **Toolbar:** Wires

 **Menu:** Wires ► Multiple Wire Bus

 **Command entry:** AEMULTIBUS

Multiple bus wiring breaks automatically and reconnects to any underlying components in its path. If it crosses existing wiring, wire-crossing gaps insert automatically based on the drawing properties. You define the number of wires.

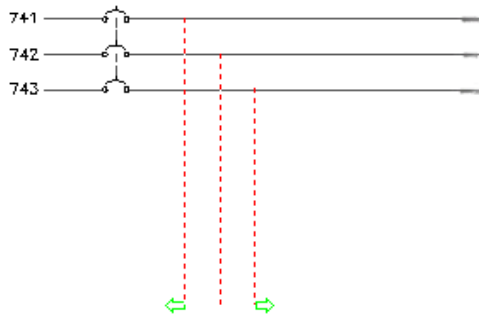

Inserts vertical or horizontal bus wiring. Bus spacing defaults to the default ladder rung spacing for horizontal bus. For a vertical bus, the spacing is the default value defined in the Ladder Defaults section in the Drawing Properties ► Drawing Format dialog box.

---

**NOTE** You can use the Scoot command to adjust bus spacing after insertion.

---

**Horizontal** Specifies the horizontal spacing between the wires.

**Vertical** Specifies the vertical spacing between the wires.

## Interconnect components

### Interconnect components

Inserts wires between aligned connection points on a pair of selected components.

- 1 Click Schematic tab ► Insert Wires/Wire Numbers panel ► Insert Wires



drop-down ► Interconnect Components.

- 2 Select the first component.
- 3 Select the second component.

---

**NOTE** Wires are added only if the wire connection points are aligned.

---

# Trim wires

## Trim wires

Use this tool to remove a wire segment and wire tees as required. You can pick on a single wire or draw a fence through multiple wires to trim.

- 1 Click Schematic tab ► Edit Wires/Wire Numbers panel ► Trim Wire.



- 2 Select the wire segment to remove on the drawing or type F followed by a [space] to remove multiple wires at once.
- 3 If you are removing multiple wires, draw a fence through the wires to trim.

A Zoom Extents is triggered when a wire runs off the screen. If this zooming back and forth becomes annoying during multiple trims, then zoom back so that all the circuitry is shown on the screen. Or press Z and [space] at the trim prompt. It triggers a Zoom Extents that persists through the rest of the trimming edits.

---

**NOTE** You can use the AutoCAD Erase command to remove wires, but wire connection dots or tees are not removed automatically.



---

## Trim wire

Trims wire between wire connections.

-  **Ribbon:** Schematic tab ► Edit Wires/Wire Numbers panel ► Trim Wire.



-  **Toolbar:** Main Electrical
-  **Menu:** Wires ► Trim Wire
-  **Command entry:** AETRIM

Removes a wire segment and any wire tees or dots. Pick on a single wire, draw a fence, or draw a crossing window to select the wires to trim.

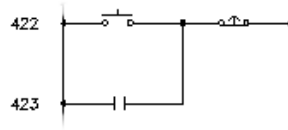
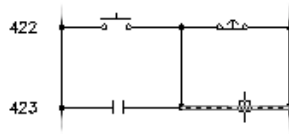

- Fence** Draw a fence line through all wire segments to trim.
- Zext** Zoom Extents so that all wire segments are visible on the screen.
- Crossing** Draw a crossing window selecting all wire segments to trim.
- Select wire to trim** Select a single wire segment to trim.

## Stretch wires

### Stretch wires

Stretches or trims the end of a wire segment to the nearest wire or in-line component wire connection point.

Select the wire, and the program automatically finds the wire or component in its path.

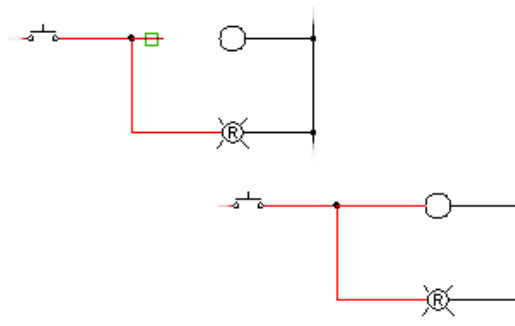

- 1 Click Schematic tab ► Edit Wires/Wire Numbers panel ► Modify

Wires drop-down ► Stretch Wire.



- 2 Select the end of the wire to stretch.

## Bend wires at right angles

### Bend wires at right angles

Bends a wire in a right angle and makes three right angle turns to avoid or add geometry.

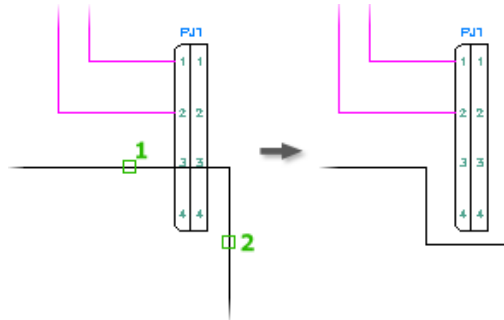

You can modify the wire defined at a right angle. You can replace the right angle bend while maintaining the original wire connections to the components.

---

**NOTE** This tool terminates if the bend attempts to connect two different wire networks or if the bend bypasses more than a single right-angle turn.

---

- 1 Click Schematic tab ► Edit Wires/Wire Numbers panel ► Modify Wires

drop-down ► Bend Wire.



- 2 Select one of the two wires that make up a right-angle turn.
- 3 Select the opposing wire that makes up the right-angle turn.  
The additional wire segments are added based on the right-angle direction.

- 4 Right-click to exit the command.

## Overview of wire color/gauge labels

When you select a wire to label, AutoCAD Electrical reads the layer name of the wire, retrieves the matching text label, and inserts it as a label/leader on the drawing. The resulting wire color/gauge label is automatically revised if you change the wire layer of a labeled wire.

The mapping file is an ASCII text file with a ".wdw" extension. The default mapping file, default.wdw, is referenced if a project-specific .wdw file is not found. The mapping file lists each wire layer name followed by the wire color/gauge label text to assign to that wire layer.

You can easily set up or edit these labels. Select the wire color/gauge tool and select Setup to display the setup dialog. All the valid layer names of the current drawing are listed in the upper dialog box list along with any matching labels found in the ".wdw" file (if it exists). Highlight any layer name and type in the label you want to associate with it. Use the "|" character to trigger a line break within your label text. For example, "RED\_14\_THHN:RED|AWG#14" causes wire labels for layer "RED\_14\_THHN" to display as two-line "RED" and "AWG#14" labels. Your entries are saved to the ".wdw" file for instant reference as you insert wire color/gauge labels.

### About automatic wire leaders

AutoCAD Electrical places wire numbers on leaders when it determines that the wire number text bumps into something (it does not check if the leader itself collides with something). AutoCAD Electrical first makes 15 tiny step checks in the "up" direction. If it fails it checks 15 steps in the down direction. If it fails, it tries at approximately 60-degree angles. If all checks fail, it leaves the wire number where it originally was going to put it. This entire process takes just a split second.

Leader checks are triggered when wire numbers are inserted or they re-center due to an adjacent SCOOT operation. If a component is scooted and the result is enough room for a wire number on a leader to do without the leader, AutoCAD Electrical automatically removes the leader and positions the wire number just above the wire.

### Map wire type labels to each wire layer

This tool maps a wire color/gauge/wire type label to each wire layer.

- 1 Click Schematic tab ➤ Insert Wires/Wire Numbers panel ➤ Wire

Number Leader drop-down ➤ Wire Color/Gauge Labels. 

- 2 Click Setup to change the text size, arrow style, and layers for the label.
  - Select the layer name to add/modify the default color/gauge text string for wire labels and leaders.

To add or modify the default color/gauge text string, select the layer name from the list in the Wire label color/gauge setup dialog box. To add new wire layer names, use the [Create/Edit Wire Type](#) on page 897 dialog box.
  - Set the text size, arrow size, arrow type, and gap size for the leader.



The label text size follows the current AutoCAD DIMTXT setting and the arrow size defaults to the current AutoCAD DIMASZ setting.
  - Specify the leader layer and text layer.
  - Click OK to apply the changes to the wire labels. The specified leader and text layers are displayed in the dialog box under the Setup button.
- 3 Select how to place the label in the drawing: automatic placement by AutoCAD Electrical, by picking the leader location point, or by picking the location for the text label with no leader. If you picked Auto placement, AutoCAD Electrical looks for a clear spot and insert the leader/label automatically.

## Insert wire color/gauge labels

Inserts a wire color /gauge label with or without a leader..

 **Ribbon:** Schematic tab ➤ Insert Wires/Wire Numbers panel ➤ Wire

Number Leader drop-down ➤ Wire Color/Gauge Labels. 

 **Toolbar:** Wire Leaders 

 **Menu:** Wires ➤ Wire Numbers Miscellaneous ➤ Wire Color/Gauge Labels

 **Command entry:** AEWIRECOLORLABEL

In Setup, set the default color/gauge text string, text size, arrow size, gap size, and arrow type for the wire label/leaders. In the Create/Edit Wire Type dialog box, add new wire layer names.

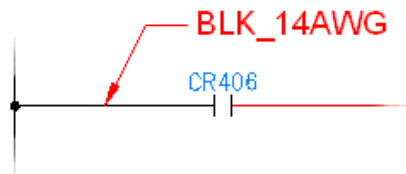

<b>Setup</b>	Sets the default color/gauge text string, text size, arrow size, gap size, and arrow type for the wire label/leaders. To add or modify the default color/gauge text string, select the layer name from the list in the Wire label color/gauge setup dialog box. To add new wire layer names, use the Wires ► Create/Edit Wire Type dialog box.
<b>Manual/No Leader</b>	Places the text label (with no leader) at a selected location.
<b>Auto Placement</b>	Places the label on the drawing automatically. AutoCAD Electrical looks for a good spot to place the label and the label is automatically placed without any picking on your part.
<b>Manual</b>	Places the label at the selected leader location point.

## Insert in-line wire markers

### Insert in-line wire markers

Inserts a reference-only in-line wire label.

Labels can identify a special signal name or conductor color. Wire numbering and reporting ignore these reference-only labels.





---

**NOTE** The wire breaks around the inline marker.

---

- 1 Click Schematic tab ► Insert Wires/Wire Numbers panel ► Wire



Number Leader drop-down ► In-Line Wire Labels.

The Insert Component dialog displays with a selection of predefined in-line markers and user-defined markers.

- 2 Select a marker and place it on a wire.

---

**NOTE** If the label is too wide, use the Squeeze Attribute/Text tool. You can also use the Adjust In-Line Wire/Label Gap tool to adjust the gap width rather than squeezing the attribute to fit the gap.

---

- 3 Press ESC to exit the command.

---

**TIP** You can also create wider marker symbols by following the [block naming convention for terminal symbols](#) on page 294. For example, the horizontal Red marker's file name is C:\Documents and Settings\All Users\Documents\Autodesk\Acade 2007\Libs\Jic1\jic1\HTO\_RED.dwg and the vertical version is C:\Documents and Settings\All Users\Documents\Autodesk\Acade {version}\Libs\Jic1\jic1\VTO\_RED.dwg. Libraries are in C:\Users\Public\Documents\Autodesk\Acade 2007\Libs\ on a Windows Vista or Windows 7 installation. AutoCAD Electrical keys off of the first four characters of the block/drawing name.

---

## **Insert component**

This icon menu can be modified, expanded, or replaced with a custom menu. You can change the default icon menu using the Library and Icon Menu Paths

section of the [Project properties: project settings tab](#) on page 204. Use the Icon Menu Wizard to modify the menu. The default icon menu can also be redefined in *wd.env*. Add entry "WD\_MENU" for schematic icon menu and "WD\_PMENU" for panel layout icon menu.

### Insert Component

 **Ribbon:** Schematic tab ► Insert Components panel ► Insert Components

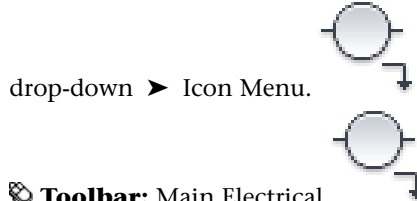

drop-down ► Icon Menu.

 **Toolbar:** Main Electrical

 **Menu:** Components ► Insert Component

 **Command entry:** AECOMPONENT

### Multiple Insert (Icon Menu)

 **Ribbon:** Schematic tab ► Insert Components panel ► Multiple Insert

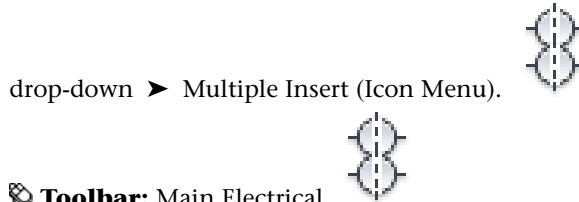

drop-down ► Multiple Insert (Icon Menu).

 **Toolbar:** Main Electrical

 **Menu:** Components ► Multiple Insert ► Multiple Insert (Icon Menu)

 **Command entry:** AEMULTI

---

**NOTE** This dialog box is also accessed when inserting Pneumatic, Hydraulic, or P&ID components; in-line wire labels; stand-alone cross-reference symbols; cable markers; and saved circuits.

---

Select an icon picture or the component type from the Menu tree structure. The main menu in the tree structure is displayed as the menu heading just above the menu tree structure.

#### Tabs

- Menu: Changes the visibility of the Menu tree view.
- Up one level: Displays the menu that is one level before the current menu in the Menu tree view. This option is unavailable if the main menu is selected in the Menu tree view.

- Views: Changes the view display for the Symbol Preview window and Recently Used window. The current view option is indicated with a check mark. Options include: Icon with text, Icon only or List view.

<b>Menu</b>	The tree structure is created by reading the icon menu file (.dat). The tree structure is based on the arrangement order of submenus defined in the .dat file.
<b>Symbol Preview window</b>	<p>Displays the symbol and submenu icons corresponding to the menu or the submenu selected in the Menu tree structure. Clicking on the icon performs one of the following functions based on the icon properties as defined by the .dat file:</p> <ul style="list-style-type: none"> <li>■ Inserts the symbol or circuit onto the drawing</li> <li>■ Executes a command</li> <li>■ Displays a submenu</li> </ul> <hr/> <p><b>NOTE</b> When you move the cursor over an icon, the icon name and block/circuit/command name display as tooltip information.</p> <hr/>
<b>Recently Used</b>	Displays the last components inserted during the current editing session; the most recently used icon displays in the top. This list follows the view options setting in the symbol preview window (icon only, icon with text or list view). The total number of icons displayed depends on the value specified in the Display edit box.
<b>Display</b>	Specifies the number of icons to display in the Recently Used list box. Enter integer numbers only; the default value is 10.
<b>Vertical/Horizontal</b>	Inserts the icon using a vertical or horizontal orientation. This value is opposite the default ladder rung orientation for the drawing.
<b>No edit dialog</b>	Turns off the Insert/Edit Component dialog box when inserting symbols onto the drawing. To add component detail later, click the Edit Component tool, and select the component to edit.
<b>No tag</b>	Inserts the component, untagged (that is, without assigning a unique Component Tag). The untagged value that displays is the TAG1/TAG2 default value for the component. To add component

detail later, click the Edit Component tool, and select the component to edit.

<b>Always display previously used menu</b>	Indicates to display the previously used menu each time you open the Insert Component dialog box. For example, if you insert a push button from the Push Buttons menu, the next time you open the Insert Component dialog box the Push Button menu displays by default.
<b>Scale schematic</b>	Specifies the component block insertion scale. This defaults to the value set in the Drawing Properties ► Drawing Format dialog box. Once set, this value is remembered until reset or until the drawing editing session ends.
<b>Scale panel</b>	Specifies the footprint insertion scale. This defaults to the value set in the Drawing Properties ► Drawing Format dialog box. Once set, this value is remembered until reset or until the drawing editing session ends.
<b>Type it</b>	Manually type in the component block to insert.
<b>Browse</b>	Browses to and selects the component to insert.

## Right-click menus

### Options for the Menu tree structure view

Right-click on the main menu or submenu in the Menu tree structure view to display the following options:

- Expand/Collapse: Toggles the visibility of the menus.
- Properties: Opens a Properties dialog box to view the existing menu or submenu properties like the menu name, image, or submenu title. Use the Icon Menu Wizard to change any menu properties.

### Options for the Symbol Preview window

Right-click an icon or in empty space in the Symbol Preview window to display the following options:

- View: Changes the view display for the Symbol Preview window and Recently Used window. The current view option is indicated with a check mark. Options include: Icon with text, Icon only or List view.

- **Properties:** (available for icons only) Opens a Properties dialog box to view the existing symbol icon properties like the icon name, image, block names and so on. Use the Icon Menu Wizard to change any icon properties.

### **Pneumatic, Hydraulic, and P&ID icon menus**

The Menu tree structure displays the symbols for the selected component type (pneumatic, hydraulic, or P&ID). The Insert Pneumatic Component, Insert Hydraulic Component, and Insert P&ID Component tools are accessed from the Schematic tab ► Insert Components panel on the ribbon or the Extra Library toolbar.



Insert Pneumatic Component



Insert Hydraulic Component



Insert P&ID Component

## **Cable Markers**

### **Insert cable markers into wires**

You can insert parent and child cable marker symbols into wires. These markers carry a cable TAG value, just like any parent/child device combination. They can also carry a conductor color value on the RATING1 attribute value. The parent symbol can have catalog part number information. If the catalog for the cable is referenced in the [cable conductor database table](#) on page 953, AutoCAD Electrical can track conductors used versus conductors available.

## Insert cable markers into wires

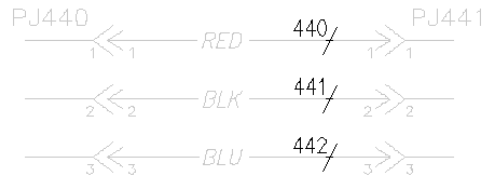

You can insert parent and child cable markers into wires. These markers carry a cable TAG value, just like any parent/child device combination.

- 1 Click Schematic tab ► Insert Wires/Wire Numbers panel ► Cable



Markers drop-down ► Cable Markers.

- 2 In the Insert Component dialog box, select the cable marker to insert and pick the insertion point on the drawing.  
The Insert/Edit Cable Marker dialog box displays.
- 3 Set the cable tag by keeping the default, using the buttons, or typing in a new tag.  
Select Fixed to mark this tag that it is not updated on a future retag.
- 4 Define the wire color by selecting it from a list or typing the color ID in the edit box.

---

**NOTE** If this area is unavailable, the component you are editing does not carry a RATING1 attribute. The one-line cable marker symbols by default do not have a RATING1 attribute.

---

Subsequent insertions of child cable markers, tied back to the parent through any of the normal methods, causes AutoCAD Electrical to offer the next conductor color of the cable as a default.

- 5 Assign the catalog information, description, location and installation codes, and references for the tag.
- 6 Click OK.  
If a parent cable marker was inserted, the Insert Some Child Components dialog box displays. Insert child cable markers automatically that are tied to the parent.

---

**NOTE** If the parent is a one-line symbol, the Insert Some Child Components dialog box does not display.

---

- 7 If you want to insert child markers, change the dialog box and click Ok insert Child. If you do not want any child markers to be associated with the parent marker, click Close.

---

**NOTE** You can use the Dashed Link Line command to insert linked lines between the symbols.

---

## Insert component

This icon menu can be modified, expanded, or replaced with a custom menu. You can change the default icon menu using the Library and Icon Menu Paths section of the [Project properties: project settings tab](#) on page 204. Use the Icon Menu Wizard to modify the menu. The default icon menu can also be redefined in *wd.env*. Add entry "WD\_MENU" for schematic icon menu and "WD\_PMENU" for panel layout icon menu.

### Insert Component

 **Ribbon:** Schematic tab ► Insert Components panel ► Insert Components

drop-down ► Icon Menu.



 **Toolbar:** Main Electrical

 **Menu:** Components ► Insert Component

 **Command entry:** AECOMPONENT

### Multiple Insert (Icon Menu)

 **Ribbon:** Schematic tab ► Insert Components panel ► Multiple Insert

drop-down ► Multiple Insert (Icon Menu).



 **Toolbar:** Main Electrical

 **Menu:** Components ► Multiple Insert ► Multiple Insert (Icon Menu)

## **Command entry: AEMULTI**

---

**NOTE** This dialog box is also accessed when inserting Pneumatic, Hydraulic, or P&ID components; in-line wire labels; stand-alone cross-reference symbols; cable markers; and saved circuits.

---

Select an icon picture or the component type from the Menu tree structure. The main menu in the tree structure is displayed as the menu heading just above the menu tree structure.

### **Tabs**

- **Menu:** Changes the visibility of the Menu tree view.
- **Up one level:** Displays the menu that is one level before the current menu in the Menu tree view. This option is unavailable if the main menu is selected in the Menu tree view.
- **Views:** Changes the view display for the Symbol Preview window and Recently Used window. The current view option is indicated with a check mark. Options include: Icon with text, Icon only or List view.

### **Menu**

The tree structure is created by reading the icon menu file (.dat). The tree structure is based on the arrangement order of submenus defined in the .dat file.

### **Symbol Preview window**

Displays the symbol and submenu icons corresponding to the menu or the submenu selected in the Menu tree structure. Clicking on the icon performs one of the following functions based on the icon properties as defined by the .dat file:

- Inserts the symbol or circuit onto the drawing
- Executes a command
- Displays a submenu

---

**NOTE** When you move the cursor over an icon, the icon name and block/circuit/command name display as tooltip information.

---

### **Recently Used**

Displays the last components inserted during the current editing session; the most recently used icon displays in the top. This list follows the view options setting in the symbol preview window (icon only, icon with text or list view). The total number of icons displayed depends on the value specified in the Display edit box.



<b>Display</b>	Specifies the number of icons to display in the Recently Used list box. Enter integer numbers only; the default value is 10.
<b>Vertical/Horizontal</b>	Inserts the icon using a vertical or horizontal orientation. This value is opposite the default ladder rung orientation for the drawing.
<b>No edit dialog</b>	Turns off the Insert/Edit Component dialog box when inserting symbols onto the drawing. To add component detail later, click the Edit Component tool, and select the component to edit.
<b>No tag</b>	Inserts the component, untagged (that is, without assigning a unique Component Tag). The untagged value that displays is the TAG1/TAG2 default value for the component. To add component detail later, click the Edit Component tool, and select the component to edit.
<b>Always display previously used menu</b>	Indicates to display the previously used menu each time you open the Insert Component dialog box. For example, if you insert a push button from the Push Buttons menu, the next time you open the Insert Component dialog box the Push Button menu displays by default.
<b>Scale schematic</b>	Specifies the component block insertion scale. This defaults to the value set in the Drawing Properties ► Drawing Format dialog box. Once set, this value is remembered until reset or until the drawing editing session ends.
<b>Scale panel</b>	Specifies the footprint insertion scale. This defaults to the value set in the Drawing Properties ► Drawing Format dialog box. Once set, this value is remembered until reset or until the drawing editing session ends.
<b>Type it</b>	Manually type in the component block to insert.
<b>Browse</b>	Browses to and selects the component to insert.

## **Right-click menus**

### **Options for the Menu tree structure view**

Right-click on the main menu or submenu in the Menu tree structure view to display the following options:

- Expand/Collapse: Toggles the visibility of the menus.
- Properties: Opens a Properties dialog box to view the existing menu or submenu properties like the menu name, image, or submenu title. Use the Icon Menu Wizard to change any menu properties.

#### Options for the Symbol Preview window

Right-click an icon or in empty space in the Symbol Preview window to display the following options:

- View: Changes the view display for the Symbol Preview window and Recently Used window. The current view option is indicated with a check mark. Options include: Icon with text, Icon only or List view.
- Properties: (available for icons only) Opens a Properties dialog box to view the existing symbol icon properties like the icon name, image, block names and so on. Use the Icon Menu Wizard to change any icon properties.

#### Pneumatic, Hydraulic, and P&ID icon menus

The Menu tree structure displays the symbols for the selected component type (pneumatic, hydraulic, or P&ID). The Insert Pneumatic Component, Insert Hydraulic Component, and Insert P&ID Component tools are accessed from the Schematic tab ► Insert Components panel on the ribbon or the Extra Library toolbar.



Insert Pneumatic Component



Insert Hydraulic Component



Insert P&ID Component

#### Insert or edit cable marker (parent wire)

Inserts parent and child cable markers.

**Ribbon:** Schematic tab ► Insert Wires/Wire Numbers panel ► Cable

Markers drop-down ► Cable Markers.



**Toolbar:** Main Electrical

**Menu:** Wires ► Cables ► Cable Markers

**Command entry:** AECABLEMARKER

In the Insert Component dialog box, select the marker to insert from the Symbol Preview window and specify the insertion point.

A cable marker carries a component tag value, like any parent/child device combination. It also carries a conductor color value, carried on the RATING1 attribute on the marker block symbol. The parent symbol can carry catalog part number information. If the cable is referenced in the cable conductor database table in the catalog database, the application can track conductors used versus conductors available.

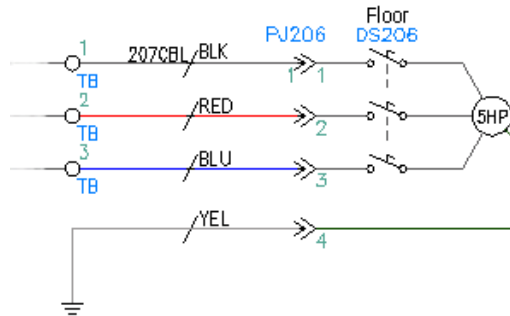

---

**NOTE** A one-line cable marker symbol, as defined by a [WDTYPE attribute](#) on page 325 value of "1-", does not carry the RATING1 attribute.

---

### Cable Tag

There are a few ways to define the tag for this cable. If there is an existing tag, it appears in the edit box. If not, you can type a specific tag in the edit box.

Make sure that you select Fixed if you want AutoCAD Electrical to mark this tag so it is not updated on a retag.

<b>Use PLC Address</b>	Searches for a wire connection to a nearby PLC I/O address and, if found, uses the PLC address number in the tag name of the component.
<b>Use End Locations</b>	Uses the location codes of the connecting components.
<b>Tags: Used so far</b>	Lists any cable tag names in the same family as the current cable. Select a tag from the list to copy, or to increment for this new cable marker.
<b>External List</b>	Assigns a tag from an external list file. You can reference an ASCII text file in comma or space delimited format to help annotate the description, tag, catalog, and other information of the component.

### Wire Color/ID

Set the conductor color code by manually entering it in the edit box or selecting from the project, drawing, or generic pick list.

<b>Generic</b>	Select from a list of colors. The list is defined in the file, <a href="#">cblcolor.dat</a> on page 954.
<b>Drawing</b>	Lists the wire colors used for similar cable markers in the current drawing.
<b>Project</b>	Lists the wire colors used for similar cable markers in the project.

---

**NOTE** If this area is unavailable, the component you are editing does not carry a RATING1 attribute.

---

### Catalog Data

You can instruct AutoCAD Electrical to do a drawing-wide or project-wide listing of similar cable markers with their catalog assignments. During your editing session, the last MFG / CAT / ASSYCODE assignment for each component type you insert into your wiring diagram is remembered. When you insert another component of that type, the catalog assignment of the

previous component is set as the default. (The assumption is that a previous one was made during the current editing session).

<b>Manufacturer</b>	Lists the manufacturer number for the cable marker. Enter a value or select one from the Catalog lookup.
<b>Catalog</b>	Lists the catalog number for the cable marker. Enter a value or select one from the Catalog lookup.
<b>Assembly</b>	Lists the assembly code for the cable marker. The Assembly code is used to link multiple part numbers together.
<b>Item</b>	Specifies a unique identifier assigned to each cable marker. The tag value can be manually typed in the edit box.
<b>Count</b>	Specifies the quantity number for the part number (blank=1). This value gets inserted into the "SUBQTY" column of the BOM report.
<b>Lookup</b>	Opens the catalog database of the cable marker from which you can manually enter or select the Manufacturer or Catalog values. Search the database for a specific catalog item to assign to the selected cable marker.
<b>Previous</b>	Scans the previous project to find an instance of the selected cable marker and returns the marker values. You can then make your catalog assignment by picking from the dialog box list.
<b>Drawing</b>	Lists the part numbers used for similar cable markers in the current drawing.
<b>Project</b>	<p>Lists the part numbers used for similar cable markers in the project. You can search in the active project, another project, or in an external file.</p> <ul style="list-style-type: none"><li>■ <b>Active project:</b> All the drawings in the current project are scanned and the results are listed in a dialog box. Select from the list to assign your new cable marker with a catalog number that is consistent with other similar cable markers in the project.</li><li>■ <b>Other project:</b> Scans each listed drawing in a previous project for the target cable marker type and returns the catalog information in a subdialog box. Make your catalog assignment by picking from the dialog box list.</li><li>■ <b>External file:</b> You can pull catalog assignments from a generic ASCII file created by a word processor or output from a spread-</li></ul>

sheet or database program. A dialog box displays the contents of the selected text file. Find and highlight the desired entry. AutoCAD Electrical reads the line of text from the file and breaks it into its component parts. They are displayed in the left-hand dialog box list. For each relevant item, highlight it and then pick the appropriate category button in the center column. The highlighted item is transferred to the corresponding category (and then to the Insert/Edit dialog box once OK is clicked).

- Multiple Catalog** Inserts or edits extra catalog part numbers on to the selected cable markers. You can add up to ten part numbers to any cable markers. These multiple BOM part numbers appear as subassembly part numbers to the main catalog part number in the various BOM and component reports.
- Catalog Check** Displays what the selected item looks like in a Bill of Material template.

### **Description**

One, two, or three lines of description attribute text can be entered.

- Drawing** Displays a list of descriptions found in the current drawing so you can pick similar descriptions to edit.
- Project** Displays a list of descriptions found in the project so you can pick similar descriptions to edit.
- Defaults** Opens an ASCII text file from which you can select standard descriptions.
- Pick** Picks a description from a cable marker on the current drawing.

### **Child conductor references**

- Component override** Overrides the WD\_M block settings of the drawing with component-specific cross-reference settings. Click Setup to edit the component cross-reference settings manually.
- Cross Reference** AutoCAD Electrical automatically fills in cross-reference text when the cross-reference command is run.

### Installation Code

Changes the installation codes. You can search the current drawing or entire project for installation codes. AutoCAD Electrical does a quick read of all the current or selected drawing files and returns a list of all installation codes used so far. Pick from the list to update the component automatically with the installation code.

Assign short installation codes to components like "PNL" and "FIELD." Later, you can take full advantage of the AutoCAD Electrical ability to create location-specific BOM and component lists.

### Location Code

Changes the location codes. You can search the current drawing or entire project for location codes. AutoCAD Electrical does a quick read of all the current or selected drawing files and returns a list of all location codes used so far. Pick from the list to update the component with the location code automatically.

Assign short location codes to components like "PNL" and "FIELD." Later, you can take full advantage of the AutoCAD Electrical ability to extract wire and cable from/to reports, and location-specific BOM reports. (For example, BOM for all field cables, BOM for all PNL cables.)

### Show/edit miscellaneous

View or edit any attributes that are not predefined AutoCAD Electrical attributes.

### Insert or edit cable marker (parent wire): IEC



Cable markers carry a cable TAG value, just like any parent/child device combination. They can also carry a conductor color value (carried as a RATING1 attribute value on the marker block symbol). The parent symbol has provision to carry MFG/CAT part number information. If the particular cable is referenced in the AutoCAD Electrical cable conductor database table (\_WO\_CBLWIRES within your Access catalog file), AutoCAD Electrical can track conductors used versus conductors available.

 **Ribbon:** Schematic tab ► Insert Wires/Wire Numbers panel ► Cable



Markers drop-down ► Cable Markers.



-  **Toolbar:** Main Electrical
-  **Menu:** Wires ► Cables ► Cable Markers
-  **Command entry:** AECABLEMARKER

Select Cable Marker from the list.

It is Insert/Edit Cable Marker (Parent wire) dialog box for working in IEC mode. If you work in JIC mode, the dialog box displays differently.

### Installation

Changes the installation codes. You can search the current drawing or entire project for installation codes. A quick read of all the current or selected drawing files is done and a list of installation codes used so far is returned. Select from the list to update the component with the installation code automatically.

Assign short installation codes to components like "PNL" and "FIELD" so you can create location-specific BOM and component lists later.

### Location

Changes the location codes. You can search the current drawing or entire project for location codes. A quick read of all the current or selected drawing files is done and a list of location codes used so far is returned. Select from the list to update the component automatically with the location code.

Assign short location codes to components like "PNL" and "FIELD." You can extract cable from/to reports and location-specific BOM reports later (for example, BOM for all field cables, BOM for all PNL cables).

### Cable Tag

Any existing tags appear in the edit box. To define the cable tag, edit the tag or type a specific tag in the edit box. Select Fixed if you do not want this tag to update on a retag.

<b>Use PLC address</b>	Searches for a wire connection to a nearby PLC I/O address and, if found, uses the PLC address number in the tag name of the component.
<b>Use end locations</b>	Uses the location codes of the connecting components.



<b>Tags: Used so far</b>	Lists any cable tag names in the same family as the current cable. Select a tag from the list to copy, or to increment for this new cable marker.
<b>External list file</b>	Assigns a tag from an external list file.

### **Description**

Up to three lines of description attribute text can be entered. These lines are automatically filled with a copy of the description text of the parent if the parent TAG name is picked using one of the methods previously described.

<b>Drawing</b>	Displays a list of descriptions found in the current drawing so you can pick similar descriptions to edit.
<b>Project</b>	Displays a list of descriptions found in the project so you can pick similar descriptions to edit.
<b>Defaults</b>	Opens an ASCII text file from which you can select standard descriptions.
<b>Pick</b>	Picks a description from a component on the current drawing.

### **Catalog Data**

You can instruct AutoCAD Electrical to do a drawing-wide or project-wide listing of similar cable markers with their catalog assignments. During your editing session, the last MFG / CAT / ASSYCODE assignment for each component type you insert into your wiring diagram is remembered. When you insert another component of that type, the catalog assignment of the previous component is set as the default. The assumption is that a previous one was made during the current editing session.

<b>Manufacturer</b>	Lists the manufacturer number for the cable marker. Enter a value or select one from the Catalog lookup.
<b>Catalog</b>	Lists the catalog number for the cable marker. Enter a value or select one from the Catalog lookup.
<b>Assembly</b>	Lists the assembly code for the cable marker. The Assembly code is used to link multiple part numbers together.

<b>Item</b>	Specifies a unique identifier assigned to each cable marker. The tag value can be manually typed in the edit box.
<b>Count</b>	Specifies the quantity number for the part number (blank=1). This value gets inserted into a "SUBQTY" column of a BOM report.
<b>Lookup</b>	Opens the catalog database of the cable marker from which you can manually enter or select the Manufacturer or Catalog values. Search the database for a specific catalog item to assign to the selected cable marker.
<b>Previous</b>	Scans the previous project to find an instance of the selected cable marker and returns the marker values. You can then make your catalog assignment by picking from the dialog box list.
<b>Drawing</b>	Lists the part numbers used for similar cable markers in the current drawing.
<b>Project</b>	<p>Lists the part numbers used for similar cable markers in the project. You can search in the active project, another project, or in an external file.</p> <ul style="list-style-type: none"> <li>■ <b>Active project:</b> All the drawings in the current project are scanned and the results are listed in a dialog box. Select from the list to assign your new cable marker with a catalog number that is consistent with other similar cable markers in the project.</li> <li>■ <b>Other project:</b> Scans each listed drawing in a previous project for the target cable marker type and returns the catalog information in a subdialog box. Make your catalog assignment by picking from the dialog box list.</li> <li>■ <b>External file:</b> You can pull catalog assignments from a generic ASCII file created by a word processor or output from a spreadsheet or database program. A dialog box displays the contents of the selected text file. Find and highlight the desired entry. AutoCAD Electrical reads the line of text from the file and breaks it into its component parts. They are displayed in the left-hand dialog box list. For each relevant item, highlight it and then pick the appropriate category button in the center column. The highlighted item is transferred to the corresponding category (and then to the Insert/Edit dialog box once OK is clicked).</li> </ul>

**Multiple Catalog** Inserts or edits extra catalog part numbers on to the selected cable markers. You can add up to ten part numbers to any cable markers. These multiple BOM part numbers appear as subassembly part numbers to the main catalog part number in the various BOM and component reports.

**Catalog Check** Displays what the selected item looks like in a Bill of Material template.

### Wire Color/ID

Set the conductor color code by manually entering it in the edit box or selecting from the project, drawing, or generic pick list.

**Generic** Select from a list of colors. The list is defined in the file, [cblcolor.dat](#) on page 954.

**Drawing** Lists the wire colors used for similar cable markers in the current drawing.

**Project** Lists the wire colors used for similar cable markers in the project.

### Child conductor references

AutoCAD Electrical automatically fills in cross-reference text when the cross-reference command is run.

### Show/edit miscellaneous

View or edit any attributes that are not predefined AutoCAD Electrical attributes.

### Insert or edit cable marker (2nd+ wire of cable)

Cable markers carry a cable TAG value, just like any parent/child device combination. They can also carry a conductor color value (carried as a RATING1 attribute value on the marker block symbol).

 **Ribbon:** Schematic tab ► Insert Wires/Wire Numbers panel ► Cable

Markers drop-down ► Cable Markers.

 **Toolbar:** Main Electrical



 **Menu:** Wires ► Cables ► Cable Markers

 **Command entry:** AECABLEMARKER

Select 2+ Child Marker from the list.

### Component Tag

If the parent is visible on screen, click Parent/Sibling and select the parent (or another related marker). It automatically transfers all information to the child marker being inserted or edited.

<b>Tag</b>	The parent cable tag value can be manually typed in the edit box or selected from a drawing-wide or project-wide list of existing cables.
<b>Drawing</b>	Lists the component tags used for similar cable markers in the current drawing.
<b>Project</b>	Lists the component tags used for similar cable markers in the project.
<b>Parent/Sibling</b>	Transfers all information from the parent cable marker to the child cable marker being inserted or edited. If the parent is visible on the screen, click Parent/Sibling and select the parent (or another related contact).

### Wire Color/ID

Set the conductor color code by manually entering it in the edit box or selecting from the project, drawing, or generic pick list. If the parent marker carries a part number, you can select the next unused color from a used/unused pick list.

<b>Generic</b>	Select from a list of colors. The list is defined in the file, <a href="#">cblcolor.dat</a> on page 954.
<b>Drawing</b>	Lists the wire colors used for similar cable markers in the current drawing.
<b>Project</b>	Lists the wire colors used for similar cable markers in the project.

---

**NOTE** If this area is unavailable, the component you are editing does not carry a RATING1 attribute.

---

### **Description**

Up to three lines of description attribute text can be entered. These lines are automatically filled with a copy of the description text of the parent if the parent TAG name is picked using one of the methods previously described.

Click Pick to copy a description from a cable marker on the current drawing.

### **Parent cable marker cross-reference**

AutoCAD Electrical automatically fills in cross-reference text when the cross-reference command is run.

### **Installation Code**

Changes the installation codes. You can search the current drawing or entire project for installation codes. A quick read of all the current or selected drawing files is done and a list of installation codes used so far is returned. Select from the list to update the component automatically with the installation code.

Assign short installation codes to components like "PNL" and "FIELD." You can take full advantage of the AutoCAD Electrical ability to create location-specific BOM and component lists later.

### **Location Code**

Changes the location codes. You can search the current drawing or entire project for location codes. A quick read of all the current or selected drawing files is done and a list of location codes used so far is returned. Select from the list to update the component automatically with the location code.

Assign short location codes to components like "PNL" and "FIELD." You can take full advantage of the AutoCAD Electrical ability to extract wire and cable from/to reports, and location-specific BOM reports later. (For example, BOM for all field cables, BOM for all PNL cables.)

### **Show/edit miscellaneous**

View or edit any attributes that are not predefined AutoCAD Electrical attributes.

### **Insert or edit cable marker (2nd+ wire of cable): IEC**

Cable markers carry a cable TAG value, just like any parent/child device combination. They can also carry a conductor color value (carried as a RATING1 attribute value on the marker block symbol).

 **Ribbon:** Schematic tab ► Insert Wires/Wire Numbers panel ► Cable

Markers drop-down ► Cable Markers.

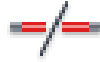

 **Toolbar:** Main Electrical

 **Menu:** Wires ► Cables ► Cable Markers

 **Command entry:** AECABLEMARKER

Select 2+ Child Marker from the list.

It is Insert/Edit Cable Marker (2nd+ wire of cable) dialog box for working in IEC mode. If you work in JIC mode, the dialog box displays differently.

### Installation

Changes the installation codes. You can search the current drawing or entire project for installation codes. A quick read of all the current or selected drawing files is done and a list of installation codes used so far is returned. Select from the list to update the component automatically with the installation code.

Assign short installation codes to components like "PNL" and "FIELD" so you can create location-specific BOM and component lists later.

### Location

Changes the location codes. You can search the current drawing or entire project for location codes. A quick read of all the current or selected drawing files is done and a list of location codes used so far is returned. Select from the list to update the component automatically with the location code.

Assign short location codes to components like "PNL" and "FIELD." You can extract cable from/to reports and location-specific BOM reports later (for example, BOM for all field cables, BOM for all PNL cables).

### Component Tag

The parent cable tag value can be manually typed into the edit box or selected from a drawing-wide or project-wide list of existing cables. If the parent is visible on screen, click Parent/Sibling and select the parent or another related marker. It automatically transfers all information to the child marker being inserted or edited.

## Description

Up to three lines of description attribute text can be entered. These lines are automatically filled with a copy of the description text of the parent if the parent TAG name is picked using one of the methods previously described.

## Wire Color/ID

Set the conductor color code by manually entering it in the edit box or selecting from the project, drawing, or generic pick list. If the parent marker carries a part number, you can select the next unused color from a used/unused pick list.

<b>Generic</b>	Select from a list of colors. The list is defined in the file, <a href="#">cblcolor.dat</a> on page 954.
<b>Drawing</b>	Lists the wire colors used for similar cable markers in the current drawing.
<b>Project</b>	Lists the wire colors used for similar cable markers in the project.

## Parent cable marker cross-reference

AutoCAD Electrical automatically fills in cross-reference text when the cross-reference command is run.

## Show/edit miscellaneous

View or edit any attributes that are not predefined AutoCAD Electrical attributes.

## Multiple cable markers

AutoCAD Electrical provides a way to insert all the markers for a particular cable from one dialog box. In addition, you can edit existing cable marker sets, or even delete cable markers from a single dialog box.

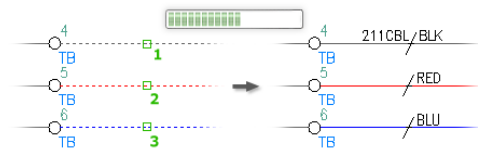

## Insert multiple cable markers

- 1 Click Schematic tab ► Insert Wires/Wire Numbers panel ► Cable



Markers drop-down ► Multiple Cable Markers.

- 2 Select to run a report for the project or drawing and click OK.  
AutoCAD Electrical processes the drawing or project before the Location Code Selection for From/To Reporting dialog box displays.
- 3 Pick the location codes from the left and right-hand lists.

---

**NOTE** Components that have no assigned location code are grouped under a generic "(?)" code.

---

- 4 Make any necessary changes in the From/To combination box and click OK when you are ready to run the report.  
The Cable Insert/Edit dialog box displays.
- 5 Define which wires are part of the cable by using the Include, Include All, Remove, and Remove All buttons.  
The wires for the cable are listed in the Wires Included in Cable portion of the dialog box.
- 6 Set the cable tag by keeping the default, using the buttons, or typing in a new tag. Select Fixed to mark this for this so that it is not updated on a future retag.
- 7 Set the wire color by selecting it from a list or typing the color in the edit box.  
Subsequent insertions of child cable markers, tied back to the parent through any of the normal methods causes AutoCAD Electrical to offer the next conductor color of the cable as a default.
- 8 Assign the catalog information, description, location and installation codes, and references for the tag.
- 9 Click Insert/Update Now to insert the cable or click Insert/Update Later to save the changes for later.

If you chose Now, any affected drawings are opened and the cable markers are inserted or updated. If you chose to insert/update later, your changes are saved in a file called 'projnam\_cblmrkin.upd' in the same directory path as your project file. When you are ready to insert the cables, select



Schematic tab ► Edit Wires/Wire Numbers panel ►  ► Multiple Cable Markers Update from the ribbon.

## Multiple cable markers

This tool first extracts components and wiring. Then you select "From" and "To" location code combinations to report. AutoCAD Electrical filters and formats the wiring and connected component data and reports each wire and what is connected at each end. Components that have no assigned location code are grouped under a generic "(?)" code. Component wiring that daisy-chains along a common bus (for example, hot or neutral bus) may not report in the connected sequence you expect. (You can use the AutoCAD Electrical Wire Sequence command to define wire connection sequencing for wire networks that have three or more interconnected components).

 **Ribbon:** Schematic tab ► Insert Wires/Wire Numbers panel ► Cable



Markers drop-down ► Multiple Cable Markers.



 **Toolbar:** Cable Markers

 **Menu:** Wires ► Cables ► Multiple Cable Markers

 **Command entry:** AEMULTICABLE

<b>From/To report for</b>	Specifies to process the report for the project, the entire drawing, or picked components in the drawing.
<b>List</b>	Lists drawings that appear to be out-of-date with the wire connection table of the project.
<b>Freshen wire connection table</b>	Updates the wire connection table to include the drawings that are out-of-date.
<b>Format</b>	Displays a listing of report settings files that have a prefix equal to the report type shown in the dialog box.

## Cable insert or edit

Cable markers carry a cable TAG value and a conductor color value (carried as a RATING1 attribute value on the marker block symbol).

 **Ribbon:** Schematic tab ► Insert Wires/Wire Numbers panel ► Cable

Markers drop-down ► Multiple Cable Markers.

 **Toolbar:** Cable Markers

 **Menu:** Wires ► Cables ► Multiple Cable Markers

 **Command entry:** AEMULTICABLE

Make your selections and click OK on the Wire From/To Report and the Location Code Selection for From/To Reporting dialog boxes.

### Wires from extract

Lists the wires that match the From/To locations (from the Wire From/To Report) and are not part of a cable yet. No cable marker was inserted on this wire. Use Add All, Add, Remove All, and Remove to define which wires are part of the cable. Sort the lists to make it easier to find the wires. Click Change Format to define which fields of information to show in the list to facilitate finding the wires to include in your cable.

### Cables

Lists any existing cables and the wires that belong to each cable. If there are no existing cables, then the only item in Cables is "newCBL1." Select New anytime you want to define a new cable. Otherwise, to edit a cable, select its tag from this list.

### Cable Tag

There are a few ways to define the tag for the cable. If there is an existing tag, it appears in the edit box. If not, you can type a tag in the edit box. Make sure that you select Fixed if you want AutoCAD Electrical to mark this tag so it is no updated on a retag.

<b>Cable End Locations</b>	Uses the location codes of the connecting components.
<b>Tags: Used so far</b>	Lists any cable tags already assigned. Select a tag from the list to copy, or to increment for this new cable.

**External List File**

Assigns a tag from an external list file.

**Description**

Up to three lines of description attribute text can be entered. Use List Drawing and List Project to pick similar descriptions to edit. Default opens an ASCII text file from which you can quickly pick standard descriptions.

**Installation Code**

Assign short installation codes to components like "PNL" and "FIELD" so you can take full advantage of the AutoCAD Electrical ability to create location-specific BOM and component lists later.

**Location Code**

Assign short location codes to components like "PNL" and "FIELD." You can take full advantage of the AutoCAD Electrical ability to extract wire and cable from/to reports, and location-specific BOM reports later. (For example, BOM for all field cables, BOM for all PNL cables.)

**Catalog Data**

MFG and CAT numbers can be manually entered or picked from Catalog lookup. The Assembly code is used to link multiple part numbers together. Use Drawing and Project to quickly list of part numbers used for like components. If the part number you select has a color conductor list associated with it, the available conductor colors and a list of used ones is tracked.

<b>Manufacturer</b>	Lists the manufacturer number for the cable marker. Enter a value or select one from the Catalog lookup.
<b>Catalog</b>	Lists the catalog number for the cable marker. Enter a value or select one from the Catalog lookup.
<b>Assembly</b>	Lists the assembly code for the cable marker. The Assembly code is used to link multiple part numbers together.
<b>Item</b>	Specifies a unique identifier assigned to each cable marker. The tag value can be manually typed in the edit box.
<b>Lookup</b>	Opens the catalog database of the cable from which you can manually enter or select the Manufacturer or Catalog values. Search the database for a specific catalog item to assign to the selected cable.

<b>Previous</b>	Scans the previous project to find an instance of the selected cable and returns the cable values. You can then make your catalog assignment by picking from the dialog box list.
<b>Drawing</b>	Lists the part numbers used for similar cables in the current drawing.
<b>Project</b>	<p>Lists the part numbers used for similar cables in the project. You can search in the active project, another project, or in an external file.</p> <ul style="list-style-type: none"> <li>■ <b>Active project:</b> All the drawings in the current project are scanned and the results are listed in a subdialog box. Select from the list to assign your new cable with a catalog number that is consistent with other similar cables in the project.</li> <li>■ <b>Other project:</b> Scans each listed drawing in a previous project for the target cable type and returns the catalog information in a subdialog box. Make your catalog assignment by picking from the dialog box list.</li> <li>■ <b>External file:</b> You can pull catalog assignments from a generic ASCII file created by a word processor or output from a spreadsheet or database program. A dialog box displays the contents of the selected text file. Find and highlight the desired entry. AutoCAD Electrical reads the line of text from the file and breaks it into its component parts. They are displayed in the left-hand dialog box list. For each relevant item, highlight it and then pick the appropriate category button in the center column. The highlighted item is transferred to the corresponding category (and then to the Insert/Edit dialog box once OK is clicked).</li> </ul>
<b>Multiple Catalog</b>	Inserts or edits extra catalog part numbers on to the selected cable. You can add up to ten part numbers to any cable. These multiple BOM part numbers appear as subassembly part numbers to the main catalog part number in the various BOM and component reports.
<b>Catalog Check</b>	Displays what the selected item looks like in a Bill of Material template.

### Wire Colors

Set the conductor color code by manually entering it in the edit box or by picking from a color list. The list displays the wire colors for the cable. If you have already selected catalog information, the colors in the list correspond to the specific cable type. If you have not assigned catalog information, the list is a generic set of colors.

To assign a color to a particular wire, select the wire in the list of wires for the cable. Assign the color by selecting it from the list or type it in the edit box. You can assign a color to all wires at one time by selecting Follow Color List. It assigns a color to each wire of the selected cable even if the wire already has a color assigned to it.

### Setup

Opens a dialog box for setting the parent cable marker symbol, the cable marker placement on the wire, and options for hiding children attributes.

### Insert/Update Now

Opens any affected drawings and automatically inserts or updates any cable markers.

### Insert/Update Later

Saves your changes in a file called 'projnam\_cblmrkin.upd' in the same directory path as your project file. The changes are accumulated in this file until you are ready for them. Select Schematic tab ► Edit Wires/Wire Numbers

►  ► Multiple Cable Markers Update from the ribbon to insert or update the cable markers that were saved.

## Edit the cable conductor database

You can edit the cable conductor database table (\_WO\_CBLWIRES in the default\_cat.mdb file) just like any other AutoCAD Electrical catalog table. The main Access database catalog file can be named either default\_cat.mdb or <project>\_cat.mdb. You can open it in Microsoft Access or you can edit it from within AutoCAD Electrical. To do so, right-click a cable marker and select Edit Component from the context menu. In the Insert/Edit Cable Marker dialog box, Catalog Data section, click Lookup. In the Parts Catalog dialog box, click Conductor List.

### Cable conductor database “\_WO\_CBLWIRES” table structure

The records in the cable conductor database table are structured as follows:

Field name	Width	Description
Catalog	60	Catalog number of cable

Manufacturer	24	Manufacturer code
Conductor	24	Conductor color or ID code
Gauge	24	Conductor gauge description
Recnum	N/A	Auto number field (used internally)

For a given cable part number, there is a record for each conductor within that cable. For example, a 15-conductor Belden type 8486 cable has 15 records; one for each conductor in that cable type. The Manufacturer and Catalog fields for all 15 records are marked "BELDEN" and "8486." The Conductor field carries each unique color ID of the conductor.

## Edit the list of generic colors

### Edit the list of generic colors

- Using a text file editor such as Notepad, open the file, cblcolor.dat.
  - Windows XP:** C:\Documents and Settings\{username}\Application Data\Autodesk\AutoCAD Electrical {version}\{release number}\{language}\Support\
  - Windows Vista, Windows 7:** C:\Users\{username}\AppData\Roaming\Autodesk\AutoCAD Electrical {version}\{release number}\{country code}\Support\
- Add, edit, or delete colors as needed.
- Save the file.

---

**NOTE** Do not remove the arrow at the end of the file.

---

## Insert shield symbols

### Insert shield symbols

AutoCAD Electrical provides a few special Shield symbols that graphically represent the cable shield type. There are "dumb" shields that do not carry an AutoCAD Electrical tag and there are cable marker/shields that carry an AutoCAD Electrical tag. You can have parent and child shields. You can insert

them one at a time and relate them as you would any other component or insert a group at a time.

- 1 Click Schematic tab ► Insert Components panel ► Insert Components



drop-down ► Icon Menu.

- 2 On the Insert Component dialog box, click the Miscellaneous button.
- 3 Click the Shields button.
- 4 Select the type of shield to insert into the drawing.
- 5 Pick the points on each wire for the shield/cable marker and right-click to end the selection. The shield inserts into the drawing.  
If you chose to insert a cable marker with a shield, the standard Insert/Edit Cable Marker dialog box displays.

---

**NOTE** Each successive symbol is automatically related to the parent (the top/left-most wire) as it is inserted.

---

### Add a second shield to a cable/shield representation

You can add a second shield representation to an existing set of cable/shield markers.

- 1 Click Schematic tab ► Insert Wires/Wire Numbers panel ► Cable



Markers drop-down ► Cable Markers.

- 2 Select to Add 2nd Shield.
- 3 Select an existing shield marker (either select the first or last cable/marker shield symbol).
- 4 Specify the insertion point and right-click to end the selection.

### Custom shield symbols

A special command, “wd\_cblshld\_bld {type}”, is used to insert the shield symbols and connecting lines. The {type} parameter indicates which library symbols to use to generate the shield and whether to cross the connecting lines or not. There are three symbols that are used to generate the cable shield,

a top (HW01\_#), middle (HW02\_#B), and bottom (HW02\_#) symbol. The “#” indicates whether the connecting lines should cross or not. A “1” results in straight connecting lines, and a “2” results in crossing connecting lines.

You can create your own custom top and bottom shield symbols by copying the existing symbols and adding a suffix to the symbol names after the “\_#”. For example, a new top shield symbol might be called HW01\_1U, and the corresponding bottom symbol, HW02\_1U. Modify the symbols to meet your needs. In the [icon menu](#) on page 1239 add a new command option calling “wd\_cblshld\_bld 1P”.

---

**NOTE** The same middle shield symbol can be used for all types.

---

## Wire Gaps

### Manipulate wire gaps

#### Manipulate wire gaps

##### Insert wire gaps

When a new wire crosses another, a gap/loop is inserted automatically. Under some conditions, it is necessary to add a gap/loop manually at the point of two crossing wires.

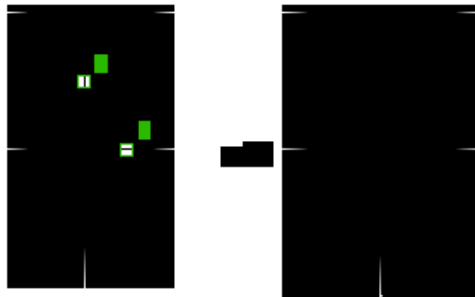

1 Click Schematic tab ► Insert Wires/Wire Numbers panel ► Insert

Wires drop-down ► Gap. 



- 2 Select the wire to remain solid.
- 3 Select the crossing wire to have the gap.  
The gap inserts into the second wire.

---

**NOTE** You can turn off the automatic gap/loop feature by selecting Solid in the Wiring Style section of the Drawing Properties ► Style dialog box.

---

### Remove wire gaps

Deletes gaps/loops that are no longer needed in an existing wire.

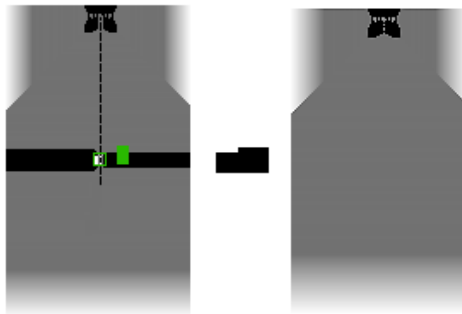

- 1 Click Schematic tab ► Edit Wires/Wire Numbers panel ►  ►

Modify Wire Gap drop-down ► Delete Wire Gap. 

- 2 Select the wire segments near the unneeded gaps.  
The gap is removed from the second wire.

### Flip wire gaps

The Flip Gap command switches a wire crossing gap or loop to the other crossing wire.

The gapped wire becomes solid and the gap/loop flips to the crossing wire.

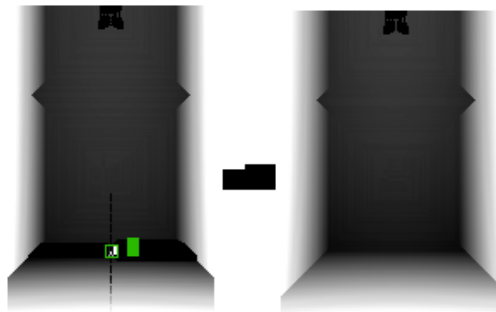

- 1 Click Schematic tab > Edit Wires/Wire Numbers panel >

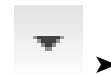

Modify Wire Gap drop-down > Flip Wire Gap.



- 2 Select the wire that has the gap/loops to flip. You can also window the wires containing the gaps to flip by pressing a W, then windowing the wires.

AutoCAD Electrical makes the gapped wire solid and flips the gap/loop to the crossing wires.

## Ladder Tools

### Define and insert new ladders

#### Set ladder defaults

You can set the new ladder width and spacing defaults by modifying a template or the attribute definitions. These default values are carried on the invisible WD\_M block.

#### Using a template

Use these steps if you are using a template drawing with a pre-inserted WD\_M block.

- 1 Open the template drawing in AutoCAD Electrical (it has a ".dwt" extension).

- 2 Click Schematic tab ► Other Tools panel ► Drawing Properties



drop-down ► Drawing Properties.

- 3 In the Drawing Properties dialog box, click the Drawing Format tab.
- 4 In the Ladder Defaults section, make the appropriate changes and click OK.
- 5 Save and exit the template drawing.

### Changing attribute values

- 1 Open the WD\_M drawing found at:  
**Windows XP:** \Documents and Settings\All Users\Documents\Autodesk\Acade {version}\libs\{library}\WD\_M.dwg  
**Windows Vista, Windows 7:** \Users\Public\Documents\Autodesk\Acade {version}\libs\{library}\WD\_M.dwg
- 2 Change the default values of the attribute definitions.
  - **DLADW:** default ladder width
  - **RUNGDIST:** default ladder rung spacing
  - **PH3SPACE:** default 3-phase spacing
- 3 Save and exit the drawing.

You can permanently change the relative position of line reference numbers and text size by modifying the RUNGFIRST attribute definition.

- 1 Display the drawing of the MLR block. The file names found at  
**Windows XP:** \Documents and Settings\All Users\Documents\Autodesk\Acade {version}\libs\{library}\  
**Windows Vista, Windows 7:** \Users\Public\Documents\Autodesk\Acade {version}\libs\{library}\  
are:
  - **WD\_MLRH.dwg:** for horizontal rung / vertical ladders
  - **WD\_MLRV.dwg:** for vertical rung / horizontal ladders

- **WD\_MLRHX.dwg**: hexagon-shaped user block (horizontal rung / vertical ladders)
  - **WD\_MLRVX.dwg**: hexagon-shaped user block (vertical rung / horizontal ladders)
- 2 Change the default values as desired, but do not delete any of the attributes you find.
  - 3 Move or change the text size of the RUNGFIRST attribute definition.
  - 4 Save and exit the drawing.

## Insert new ladder

There is no limit to the number of ladders that can be inserted into a drawing, but ladders cannot overlap each other. You can insert a new ladder at any time. Multiple ladder fragments in the same vertical column must be vertically aligned along their left-hand side. These limitations do not apply when X-Y Grid or X-Zone referencing is selected.

- 1 Click Schematic tab ► Insert Wires/Wire Numbers panel ► Insert

Ladder drop-down ► Insert Ladder. 

- 2 Specify the width and spacing of the ladder.
- 3 Specify the first reference, index, and rungs.

Index is the increment number for line reference numbering (default = 1). If you do not want every line reference number to show up then you can use the AutoCAD Erase command to get rid of the extras. Do not erase the top-most line reference number. It is the MLR block of the ladder and carries the intelligence.

---

**NOTE** It is not necessary to enter a value for the length since it is calculated once the first reference, index, and rung values are set.

---

- 4 Specify whether to create a one-phase or three-phase ladder. If you select to create a three-phase ladder, the Width and Draw Rungs options are unavailable.
- 5 Specify how to draw the rungs.  
No Bus just draws the line reference numbers, while No Rungs just draws the hot and neutral bus with rungs. Add rungs with the AutoCAD

Electrical Add Rung command or the Insert Wire tool. Select Yes to include a rung automatically at every reference location (skip = 0) or every other line reference position (skip = 1). You can specify whether to skip rungs; specifying a value of Skip = 4 means that four rungs are skipped for every one that is drawn.

- 6 Click OK.
- 7 Specify the start position of the ladder. Enter a start and end value or pick a point on the drawing.  
During ladder insertion, the current wire type displays at the command prompt. You can override it by typing in the hotkey "T" and selecting a new wire type from the Set Wire Type dialog box. The new wire type becomes the current wire type and the command continues with the ladder insertion.
- 8 Specify the last reference number for the ladder. If you entered values in the step above, this step is not necessary.
- 9 Click to insert the ladder.

---

**NOTE** Use AutoCAD Move to relocate an entire ladder. Make sure you that get the entire ladder including the first line reference number (the MLR block insert). Select the Revise Ladder button and then click Cancel on the dialog box. Using this command forces AutoCAD Electrical to reread and update its internal ladder location list.



---

## Insert ladder

Inserts a ladder with rungs and line reference numbers as specified in drawing properties.

 **Ribbon:** Schematic tab ► Insert Wires/Wire Numbers panel ► Insert

Ladder drop-down ► Insert Ladder. 

 **Toolbar:** Wires 

 **Menu:** Wires ► Ladders ► Insert Ladder

 **Command entry:** AELADDER

You can insert any number of ladders into a drawing. Ladders cannot overlap other ladders. You can insert a new ladder at any time.

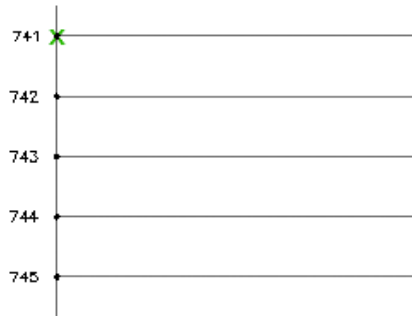

During ladder insertion, the current wire type displays at the command prompt. You can override it by typing in the hotkey “T” and selecting a new wire type from the Set/Edit Wire Type dialog box. The new wire type becomes the current wire type and the command continues with the ladder insertion.

<b>Width</b>	Specifies the width of the ladder.
<b>Spacing</b>	Specifies the spacing between each rung.
<b>Length</b>	Specifies both the length of the ladder and the number of rungs. You can enter the total ladder length, the number of ladder rungs, or leave both blank. You can manually pick the beginning and ending points of the ladder.
<b>1st reference</b>	Specifies the beginning line reference for the ladder. Index is the increment number for line reference numbering (default = 1). If you do not want every line reference number to show up then you can use the AutoCAD Erase command to get rid of the extras. Do not erase the top-most line reference number. It is the MLR block of the ladder and carries the intelligence of the ladder.
<b>Phase</b>	Specifies whether to create a one-phase or three-phase ladder. If you select to create a three-phase ladder, the Width and Draw Rungs options are unavailable.
<b>Draw rungs</b>	Specifies how to draw the rungs. No Bus just draws the line reference numbers, while No Rungs just draws the hot and neutral bus with rungs. Add rungs with the AutoCAD Electrical Add Rung command or the Insert Wire tool. Select Yes to include a rung automatically at every reference location (skip = 0) or every other line reference position (skip = 1). You can specify whether to skip

rungs; specifying a value of Skip = 4 means that four rungs are skipped for every one that is drawn.

## Modify an existing ladder

### Renumber an existing ladder

- 1 Click Schematic tab ► Edit Wires/Wire Numbers panel ► Modify Ladder



drop-down ► Revise Ladder.

- 2 Enter the new beginning line reference number and click OK.

---

**NOTE** It does not update existing components or wire numbers.

---

- 3 To update component tags to match the new line reference number, click Schematic tab ► Edit Components panel ► Retag Components



drop-down ► Retag Components.

- 4 To update the wire numbers, click Schematic tab ► Insert Wires/Wire Numbers panel ► Insert Wire Numbers drop-down ► Wire Numbers.



Select Tag/retag ALL.

If off-page wire connections are involved, make sure that you click Cross-reference Signals on the Wire Tagging dialog box.

- 5 Click Pick Individual Wires and select the wires to retag.

### Change the size of a ladder

You can use the Revise Ladder tool to shorten, lengthen, widen, or compress an existing ladder.

To lengthen or shorten the ladder:

- 1 Click Schematic tab ► Edit Wires/Wire Numbers panel ► Modify Ladder

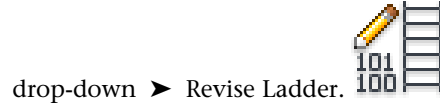

- 2 Change the column of line reference numbers to match the appropriate ladder length and click OK.
- 3 Select the AutoCAD Stretch command from the menu to lengthen or shorten the ladder.

To widen or compress the ladder:

- 1 Click Schematic tab ► Edit Components panel ► Modify Components

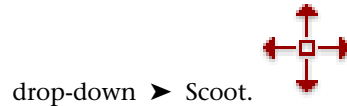

- 2 Select the vertical rail of the ladder and pull it out or push it in.
- 3 To put components back into neat columns -  
Click Schematic tab ► Edit Components panel ► Modify Components

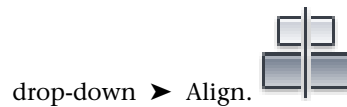

- 4 Select the components to align and press Enter.

## Reposition a ladder

You can reposition an existing ladder on your drawing using the AutoCAD Move command.

- 1 Select the AutoCAD Move command from the menu.
- 2 Select the ladder, making sure to include the first line reference number.
- 3 Click Schematic tab ► Edit Wires/Wire Numbers panel ► Modify Ladder

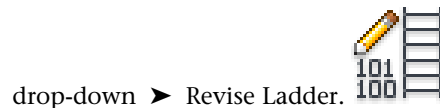

- 4 Click Cancel.



This forces AutoCAD Electrical to reread and update its internal ladder location list.

## Change rung spacing

- 1 Click Schematic tab ► Edit Wires/Wire Numbers panel ► Modify Ladder



drop-down ► Revise Ladder.

- 2 Change the column of line reference numbers to the desired rung spacing and ladder length.
- 3 Scoot (or the AutoCAD Stretch command) to move the existing rungs to their new rung locations.

Click Schematic tab ► Edit Components panel ► Modify Components



drop-down ► Scoot.

## Insert rungs

Adds a ladder rung at the line reference nearest to a point you select inside the ladder.

Both bus wires must be visible on the screen.

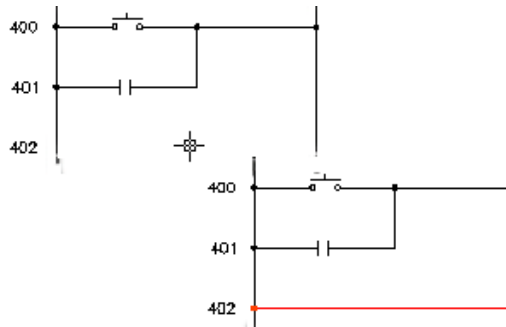

- 1 Click Schematic tab ► Edit Wires/Wire Numbers panel ► Modify Ladder



drop-down ► Add Rung.

- 2 Select a blank space anywhere between the hot and neutral bus wires to add the rung.

During rung insertion, the current wire type displays at the command prompt. You can override it by typing in the hotkey "T" and selecting a new wire type from the Set/Edit Wire Type dialog box. The new wire type becomes the current wire type and the command continues with the rung insertion.

If the new rung encounters a schematic device floating in space, it tries to break the wire across the device.

## Convert line reference numbers

Use them to convert the upper-most line reference number on a non-intelligent ladder to be aware of AutoCAD Electrical.

- 1 Click Conversion Tools tab ► Tools panel ► Convert Ladder.



- 2 Select the top line reference number and press Enter.  
The Modify Line Reference Numbers dialog box displays.
- 3 Specify the desired rung spacing, ladder length, and starting reference number.
- 4 Click OK.

## Modify line reference numbers

Renumbers ladder references and adjusts ladder-specific settings.

### Revise Ladder

 **Ribbon:** Schematic tab ► Edit Wires/Wire Numbers panel ► Modify

Ladder drop-down ► Revise Ladder.



 **Toolbar:** Ladders



 **Menu:** Wires ► Ladders ► Revise Ladder

 **Command entry:** AEREVISELADDER

## Convert Ladder

 **Ribbon:** Conversion Tools tab ► Tools panel ► Convert Ladder.



 **Toolbar:** Conversion Tools

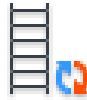

 **Menu:** Wires ► Ladders ► Convert Ladder

 **Command entry:** AE2LADDER

Select the top line reference number and press Enter.

When converting line reference numbering using the Convert Ladder tool, select only the first line reference number to determine location, size, and justification of the new line reference numbers being converted. Once OK is pressed, existing ladder information is erased and the new smart ladder is inserted.

You can adjust the line reference numbering along the side of the ladders. The existing ladder rung spacing does not change.

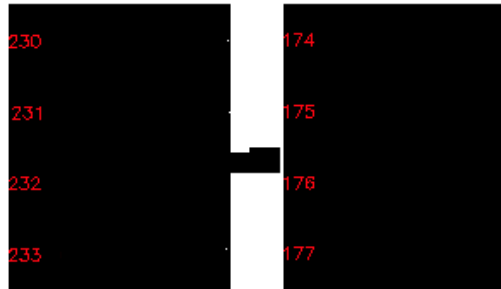

---

**NOTE** Updating the reference numbers of the ladder does not update existing components or wire numbers.

---

### Rung spacing

Specifies the spacing between each rung.

### Rung count

Specifies the number of rungs for each ladder.

### Reference numbers

Specifies the length of the ladder by adjusting the begin and end reference numbers. The first line reference number on each ladder is a smart AutoCAD block and attributes. All the rest of the numbers are

text entities (that can be erased, but do not erase the top or first line reference number).

**Index**

Specifies the line reference number increment value (default=1). Selecting Redo forces a refresh of line reference numbering.



**Wire number format**



Specifies the format for placing wire numbers. (default = configure wire number format value) You can specify a unique automatic wire numbering format on a per ladder basis (ex: one ladder of 24-volt wiring requiring wire numbers with a unique prefix or suffix, ex: %NVDC).

## Renumber Ladders

Renumbers ladder references project-wide.

 **Ribbon:** Schematic tab ► Edit Wires/Wire Numbers panel ► Modify

Ladder drop-down ► Renumber Ladder Reference.  

 **Toolbar:** Ladders 

 **Menu:** Wires ► Ladders ► Renumber Ladder Reference

 **Command entry:** AERENUMBERLADDER

**1st drawing, 1st ladder, 1st line reference number** Enter the first ladder line reference number.

**2nd drawing and beyond** Select an option for ladders on subsequent drawings.

- Use next sequential reference - increment from the last line reference on the previous drawing.
- Skip, drawing to drawing count - enter an amount to skip for the first ladder reference of the next drawing.

# Wire Numbers

## Overview of wire numbers

Wire numbers are blocks or attributes inserted on a line wire entity. AutoCAD Electrical assigns each wire number type to its own layer. You can assign a different color to each of these layers so you can easily tell them apart. There are four types of wire numbers: Normal, Fixed, Extra, and Signal.

<b>Normal</b>	Wire numbers that are free to update when you rerun the Insert Wire Numbers command.
<b>Fixed</b>	Wire numbers that are fixed to their current value. They do not update with subsequent runs of the Insert Wire Numbers command.
<b>Extra</b>	Extra copies of the Normal or Fixed wire number that are assigned to a given wire network. A single wire network has one Normal or one Fixed wire number (but not both). It cannot have many extra copies of the wire number inserted at various locations on the network.
<b>Terminal/Signal</b>	Wire numbers for terminals and signal arrows.

### Wire tag formats

The origin of a wire number block must lie on the wire segment, though the text attribute can move away from the wire. AutoCAD Electrical uses the concept of a wire tag format string with replaceable parameters. One replaceable parameter, %N, must always be part of the wire format string. A typical format string might be just this %N parameter.

Replaceable parameters for defining a default wire number tag format are:

<b>%S</b>	Sheet number of the drawing
<b>%D</b>	Drawing number
<b>%N</b>	Sequential or reference-based number applied to the component
<b>%X</b>	Suffix character position for reference-based tagging (not present = end of tag)

%P	IEC-style project code (default for drawing)
%I	IEC-style "installation" code (default for drawing)
%L	IEC-style "location" code (default for drawing)

Examples: Wire beginning on line reference "100" of sheet "02" yields these wire number tags for the following formats:

%N	wire number = 100
W%N	wire number = W100
%S-%N	wire number = 02-100
%S%N	wire number = 02100
%S : %N	wire number = 02:100

## Automatically insert wire numbers

This tool quickly processes and tags wires on the current drawing, wires in the project, or individually picked wires.

- 1 Click Schematic tab ► Insert Wires/Wire Numbers panel ► Insert Wire



Numbers drop-down ► Wire Numbers.

- 2 Select to tag all wires or only new wires.
- 3 Select to process and tag wires with sequential wire numbers or with wire numbers based on the line reference location of the wire network.
- 4 (Optional) Set other tagging options such as:
  - specify the wire tag format to use
  - specify the wire layer format
  - force all wire numbers to be fixed
  - update cross-reference text on wire signal source and destination symbols
  - update the database for wire signal source and destination symbols

- 5 Select to tag the selected wires, wires on a drawing, or wires in a project.

## Wire tagging

Inserts wire numbers as specified in drawing properties.

**Ribbon:** Schematic tab ► Insert Wires/Wire Numbers panel ► Insert

Wire Numbers drop-down ► Wire Numbers.

**Toolbar:** Main Electrical 2

**Menu:** Wires ► Insert Wire Numbers

**Command entry:** AEWIRENO

Wire numbers are blocks with attributes inserted on a line wire entity. There are four types of wire numbers: Normal, Fixed, Extra, and Signal. The AutoCAD Electrical application assigns each wire number type to its own layer. You can assign different colors to these layers.

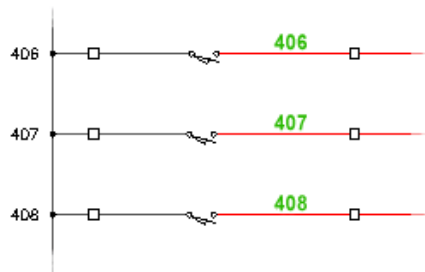

AutoCAD Electrical processes wire line entities into wire networks, and inserts or updates wire numbers associated with them.

<b>To do</b>	Specifies to process all the wiring or just the untagged (new) wires.
<b>Wire tag mode</b>	Specifies to use the sequential or line-reference based setting for the drawing.
<b>Format override</b>	Specifies the wire tag format to use for overriding the format set in the Drawing Properties dialog box.

<b>Use wire layer format overrides</b>	Overrides the default wire number format (set in the Layers section of the Drawing Properties ► Drawing Format dialog box) by using layer-defined formats.
<b>Insert as fixed</b>	Forces all wire numbers to be fixed (they do not update if wire number retagging is run again at a later date).
<b>Cross-reference Signals</b>	Updates cross-reference text on wire signal source and destination symbols.
<b>Freshen database (for Signals)</b>	Updates the database for wire signal source and destination symbols.
<b>Project-wide</b>	Tags or retags wiring project-wide.
<b>Pick individual wires</b>	Tags or retags the selected wiring on the current drawing only.
<b>Drawing-wide</b>	Tags or retags wiring on the current drawing.

## Wire tagging (project-wide)

AutoCAD Electrical processes wire line entities into wire networks, and inserts or updates wire numbers associated with them across a project.

 **Ribbon:** Schematic tab ► Insert Wires/Wire Numbers panel ► Insert

Wire Numbers drop-down ► Wire Numbers.

 **Toolbar:** Main Electrical 2

 **Menu:** Wires ► Insert Wire Numbers

 **Command entry:** AEWIRENO

Select Sequential and click Project-Wide.

**Wire tag mode** Specifies to use the sequential or line-reference based setting for the drawing.

**Sequential (1st tag defined for each drawing)** Starts at the wire number specified for that drawing (as set in the [Drawing](#)



	<a href="#">Properties &gt; Wire Numbers</a> on page 979 dialog box). A starting wire number must be assigned for each drawing.
<b>Sequential (consecutive drawing to drawing)</b>	Allows you to type in a starting wire number and increments from there, ignoring the defined setting of the starting wire number.
<b>Reference-based tags</b>	Sets the wire number based on the line-reference value.
<b>To do</b>	Specifies to process all the wiring or just the untagged (new) wires.
<b>Cross-reference Signals</b>	Updates cross-reference text on wire signal source and destination symbols.
<b>Freshen database (for Signals)</b>	Updates the database for wire signal source and destination symbols.
<b>Format override</b>	Specifies the wire tag format to use for overriding the format set in the Drawing Properties dialog box.
<b>Use wire layer format overrides</b>	Overrides the default wire number format (set in the Layers section of the Drawing Properties ► Drawing Format dialog box) by using layer-defined formats.
<b>Insert as fixed</b>	Forces all wire numbers to be fixed (they do not update if wire number retagging is run again at a later date).

## Insert special wire numbering

This tool speeds up the process of inserting special wire numbering associated with 3-phase bus and motor circuits. It can also be used in a continuous mode. You can insert a long series of incrementing wire numbers and assign each, in turn, to the wires you pick.

- 1 Click Schematic tab ► Insert Wires/Wire Numbers panel ► Insert Wire

Numbers drop-down ► 3 Phase. 

- 2 Enter a base starting number in the edit box or click Pick to select an existing attribute value on the active drawing.  
If the picked text carries a numeric substring, it is extracted and inserted into the Base edit box.
- 3 Enter an optional Prefix and/or Suffix value or choose from a default pick list by clicking List.  
The prefix or suffix value can be a comma-delimited string with each entry applied in sequence to the Wire Numbers section. The section is at the right-hand side of the dialog box.
- 4 Set the hold and increment options for each of the edit box values as required. Pay attention to the proposed generated wire numbers in the right-hand side of the dialog box.
- 5 Set the number of wire numbers needed in the bottom right-hand side of the dialog box.

---

**TIP** Select None to generate a continuous list of incrementing wire numbers.

---

- 6 Select OK.
- 7 Select the wires for the wire numbers, either single picks or using the Fence selection.  
Fence selection inserts the wire numbers at the crossing points while single selections use the default wire number placement of the drawing. (For example, centered on the wire segment.)

### Tips and Hints

- Tab out of an edit box to start the Wire Numbers listing to update.
- You can add to the default prefix and suffix list display. Create an ASCII text file and list each prefix/suffix entry, one per line in the file. Name the file <projectname>.3ph (where "projectname" is the name of your active project) or default.3ph and put the file in any folder that is part of the search path list AutoCAD Electrical.
- The wire number assignments go in as Fixed. They hold the values that you have assigned and do not retag with a subsequent run of the Insert Wire Numbers command).

---

**NOTE** If this tool does not meet your needs, use the Edit Wire Number tool to assign fixed wire numbers one at a time.

---

## 3 phase wire numbering

Inserts fixed wire numbers using incrementing prefixes and suffixes for 3 phase circuits. This tool speeds up the process of inserting special wire numbering associated with 3-phase bus and motor circuits.

 **Ribbon:** Schematic tab ► Insert Wires/Wire Numbers panel ► Insert

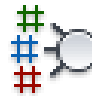
Wire Numbers drop-down ► 3 Phase. 

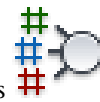
 **Toolbar:** Insert Wire Numbers 

 **Menu:** Wires ► Wire Numbers Miscellaneous ► 3 Phase Wire Numbers

 **Command entry:** AE3PHASEWIRENO

You can use 3 Phase Wire Numbers in a continuous mode. You can insert a long series of incrementing wire numbers and assign each, in turn, to the selected wires.



You can add to the default prefix and suffix list display. Create an ASCII text file and list each prefix/suffix entry, one per line in the file. Name the file <projectname>.3ph (where "projectname" is the name of your active project) or default.3ph and put the file in any folder that is part of search path list of AutoCAD Electrical.

<b>Prefix</b>	Specifies the prefix value for the wire numbers. Enter a value or click List to choose from a default pick list.
<b>Base</b>	Specifies the base starting number for the wire numbers. Enter a value or click Pick to select an existing attribute value on the active drawing.

<b>Suffix</b>	Specifies the suffix value for the wire numbers. Enter a value or click List to choose from a default pick list.
<b>Hold/Increment</b>	Specifies whether to hold or increment the prefix, base, and suffix values for all wire numbers that are entered onto the drawing. For example, if you set Base = 100/Increment and Suffix = L1/Hold, the wire numbers are 100L1, 101L1, 102L1.
<b>Wire Numbers</b>	Displays a preview of the wire numbers to insert onto the drawing. <b>TIP</b> Tab out of an edit box to trigger the Wire Numbers listing to update.
<b>Maximum</b>	Specifies the maximum number of wire numbers. When you select a new option (3, 4, or None) the Wire Numbers section automatically updates with a preview. It is based on the value selected in relation to the options specified for the prefix, base, and suffix values. <b>TIP</b> Select None to generate a continuous list of incrementing wire numbers

## PLC I/O wire numbers

Inserts wire numbers based on connected PLC I/O address values.

 **Ribbon:** Schematic tab ► Insert Wires/Wire Numbers panel ► Insert

Wire Numbers drop-down ► PLC I/O.

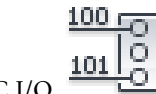

 **Toolbar:** Insert Wire Numbers

 **Menu:** Wires ► Wire Numbers Miscellaneous ► PLC I/O Wire Numbers

 **Command entry:** AEPLCWIRENO

Wire numbers go in as fixed. If you run a wire number retag later on, fixed wire numbers do not change.



- I/O Wire Tag Format:** Specifies the wire tag format for the plc wire.
- Predefined:** Uses an exact wire number match on the address. The options are I:%n or O:%n.

---

**NOTE** For automatic wire numbering based strictly on the actual I/O address, open the Drawing Properties dialog box, and click the Wire Number tab. In the Wire Numbering section, select Search for I/O address on insert.

---

### Check line entities

Some problems with wire numbering (or lack thereof) can be traced to line wires not being on a valid wire layer. The solution is to move the line entities to a valid AutoCAD Electrical wire layer using the [Change/Convert Wire Type](#) on page 908 tool.

Make a quick check of what is a wire and what is not. It highlights in bright red every line entity that is on a valid AutoCAD Electrical wire layer.

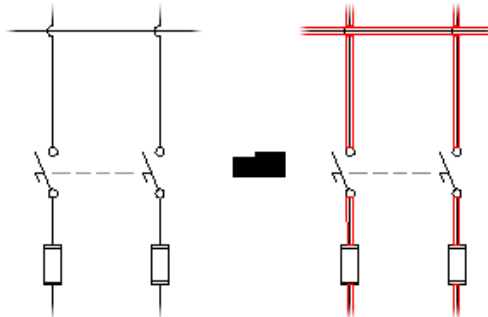

Select the AutoCAD Redraw command to remove the highlights.

- 1 Click Schematic tab ► Edit Wires/Wire Numbers panel ► Modify Wires



drop-down ► Show Wires.

- 2 Select whether to show the wires. All lines (wires) on wire layers are highlighted in:
  - Bright red - regular wires.
  - Magenta - wires on layers defined as No Wire Numbering.
- 3 Select whether to show the origin point for each wire number attribute text entity. The origin of a wire number block must lie on the wire segment, though the text attribute may be moved away from the wire.

---

**NOTE** Do not use the AutoCAD Move command to move the attribute.

---

- 4 Select whether to highlight the wire number attribute text pointed to by each Xdata pointer. Xdata pointers identify which wire number insert goes with which wire segment.

## Set wire number placement

### Set wire number placement

You can set the wire number placement for new wires inserted in a single drawing or for the entire project. It does not update existing wire numbers.

---

**TIP** Change the position of an existing wire number using the Toggle Wire Number In-Line tool.

---



- 1 Click Project tab ► Project Tools panel ► Manager.
- 2 In the Project Manager, right-click on the project name and select Properties (or click the drawing name, and select Properties ► Drawing Properties).

If you change this setting in the project properties, the drawings already in the project do not get this setting.

---

**NOTE** You can also automatically set wire number placement using the Drawing Properties tool. Follow these steps.

---

- 3 In the Project or Drawing Properties dialog box, click the Wire Numbers tab.
- 4 In the Wire Number Placement section, select how you want to place new wire numbers automatically: above, below, or inline of the wire.
  - **Above Wire:** Places the wire number above the physical wire.
  - **In-Line:** Places the wire number in line with the wire. Click Gap Setup to define the spacing between the wire number and the wire itself.
  - **Below Wire:** Places the wire number below the physical wire.
- 5 Click OK.

---

**NOTE** Use the Copy Wire Number (In-Line) tool to insert individual wire numbers inline with the wire rather than above or below the wire in the active drawing.

---

Apply drawing-specific wire number settings. These settings are maintained inside the WD\_M block in the drawing.

#### Any drawing

 **Ribbon:** Project tab ► Project Tools panel ► Manager. 

 **Toolbar:** Main Electrical 2 

 **Menu:** Projects ► Project Manager

 **Command entry:** AEPROJECT



In the Project Manager, right-click the drawing name, and select Properties ► Drawing Properties. Select the Wire Numbers tab.

#### Active drawing

 **Ribbon:** Schematic tab ► Other Tools panel ► Drawing Properties

drop-down ► Drawing Properties. 



-  **Toolbar:** Main Electrical 2
-  **Menu:** Projects ► Drawing Properties
-  **Command entry:** AEPROPERTIES

Select the Wire Numbers tab.

### Wire Number Format

Wire number tags can be sequential or reference-based.

#### Format

Specifies the way new wire number tags are created. The wire number tag format must include the %N parameter that is the base sequential or reference-based value per the selection above. If your format includes the sheet number %S parameter or the drawing number %D parameter, enter the values in the edit boxes in the Drawing Properties ► Drawing Settings dialog box.

---

**NOTE** For reference-based wire number tagging, individual items in the suffix list are applied to the wire tags to keep multiple wires in the same reference location unique. These values are added to the end of the tag, but you can force AutoCAD Electrical to insert the suffix character somewhere within the tag format. Use the Suffix position parameter, %X, in the component tag format (for example, %X%N).

---

#### Search for PLC I/O address on insert

Specifies to use PLC I/O address values for wires that connect to an addressed I/O point. This setting overrides both Sequential and Reference-based tagging. New wires or wire renumbering on the current drawing shows PLC I/O address-based wire numbers automatically.

---

**NOTE** Like component tags, AutoCAD Electrical uses the concept of a wire tag format string with replaceable parameters. The %N parameter must always be part of the wire format string. A typical format string can be just this %N parameter.

---

#### Sequential

Enter the starting sequential number (alpha, numeric, or alphanumeric) for the drawing. If you enter the same starting sequential number for every drawing of your wiring diagram set, AutoCAD Electrical confirms at insertion time



that a new sequential wire number tag is not repeated on any other drawing.

If you set DEMO1 to 100 and DEMO2 to 200, the wire numbers on DEMO1 start at 100 and wire numbers on DEMO2 start at 200. If DEMO1 has more than 100 wire numbers it starts using wire number 200 and above. DEMO2 would begin its wire numbers where DEMO1 left off (making sure that duplicate wire numbers are not assigned).

<b>Increment</b>	The default is "1." Setting it to "2" with a starting sequential of "1" would yield wire numbers 1, 3, 5, 7, 9, 11, and so on.
<b>Line Reference</b>	Sets the wire number tag suffix. This list is used to create unique reference-based wire number tags for multiple wire networks beginning at the same reference location (such as wire network beginning at a location per line reference number, X-Y grid reference, or X-Zone reference).
<b>Suffix Setup</b>	Displays a suffix list. List suffix characters for wire numbers beginning on the same line reference or in the same zone (to keep wire numbers unique). Select one of the four predefined suffix lists or enter your own custom suffix list.

### **New Wire Number Placement**

---

**NOTE** The Insert Wire Number tool does not take the current wire number setting (in-line, above or below) into account when updating existing wire numbers. This setting is used only when inserting new wire numbers. Use the Toggle Wire Number In-Line tool for flipping existing wire numbers among the three modes.

---

<b>Above Wire</b>	Places the wire number above the physical wire.
<b>In-Line</b>	Places the wire number inline with the wire.
<b>Gap Setup</b>	Defines spacing between the inline wire number and the wire itself.
<b>Below Wire</b>	Places the wire number below the physical wire.

<b>Offset</b>	Specifies to insert the wire number tags the specified offset distance.
<b>Centered</b>	Specifies to insert the wire number tags in the center of each wire segment.
<b>Offset Distance</b>	Specifies a fixed, user-defined offset distance from the left or top of the first wire segment found on the wire network.
<b>Leaders</b>	(This option is unavailable for in-line wire numbers.) AutoCAD Electrical places wire numbers on leaders when it determines that the wire number text bumps into something. It does not check if the leader itself overlays another object. Select the method for inserting new wire numbers as leaders: As Required, Always, or Never.







---

**NOTE** This change does not affect wire numbers that are already present on the drawing.

---

## Project properties: wire numbers tab

Modify your project default settings for wire numbers. All information defined in this tab is saved to the project definition file as project defaults and settings

-  **Ribbon:** Project tab ► Project Tools panel ► Manager. 
-  **Toolbar:** Main Electrical 2 
-  **Menu:** Projects ► Project ► Project Manager
-  **Command entry:** AEPROJECT

In the Project Manager, right-click on the project name and select Properties. Select the Wire Numbers tab.

### Wire Number Format

Wire number tags can be sequential or reference-based.

<b>Format</b>	Specifies the way new wire number tags are created. The wire number tag format must include the %N parameter that is the base sequential or reference-based value from the selection described. If your format includes the sheet
---------------	---

number %S parameter or the drawing number %D parameter, enter the values in the edit boxes in the Drawing Properties ► Drawing Settings dialog box.

---

**NOTE** For reference-based wire number tagging, individual items in the suffix list are applied to the wire tags to keep multiple wires in the same reference location unique. These items are added to the end of the tag, but you can force AutoCAD Electrical to insert the suffix character somewhere within the tag format. Use the Suffix position parameter, %X, in the component tag format (for example, %X%N).

---

**NOTE** AutoCAD Electrical provides a predefined format for you to use or you can enter your own format using [replaceable parameters](#) on page 236.

---

#### Search for PLC I/O address on insert

Specifies to use PLC I/O address values for wires that connect to an addressed I/O point. This setting overrides both Sequential and Reference-based tagging. New wires or wire renumbering on the current drawing show PLC I/O address-based wire numbers automatically.

---

**NOTE** Like component tags, AutoCAD Electrical uses the concept of a wire tag format string with replaceable parameters. The %N parameter must always be part of the wire format string. A typical format string can be just this %N parameter.

---

#### Sequential

Enter the starting sequential number (alpha, numeric, or alphanumeric) for the drawing. If you enter the same starting sequential number for every drawing of your wiring diagram set, AutoCAD Electrical confirms at insertion time that a new sequential wire number tag is not repeated on any other drawing.

If you set DEMO1 to 100 and DEMO2 to 200, the wire numbers on DEMO1 start at 100 and wire numbers on DEMO2 start at 200. If DEMO1 has more than 100 wire numbers it starts using wire number 200 and above. DEMO2 would begin its wire numbers where DEMO1 left off (making sure that duplicate wire numbers are not assigned).

<b>Increment</b>	The default is "1". Setting it to "2" with a starting sequential of "1" would yield wire numbers 1, 3, 5, 7, 9, 11, and so on.
<b>Line Reference</b>	Sets the wire number tag suffix. This list is used to create unique reference-based wire number tags for multiple wire networks. It begins at the same reference location (such as wire network beginning at a location per line reference number, X-Y grid reference, or X-Zone reference).
<b>Suffix Setup</b>	Displays a suffix list. List suffix characters for wire numbers beginning on the same line reference or in the same zone (to keep wire numbers unique). Select one of the four predefined suffix lists or enter your own custom suffix list.

### Wire Number Options

<b>Based on Wire Layer</b>	Assigns a different wire number format based on the wire layer.
<b>Layer Setup</b>	Overrides the default wire number format by using layer defined formats. Change the wire layer name, wire number format, starting wire sequence, and wire number suffix.
<b>Based on Terminal Symbol Location</b>	Specifies to use a wire number terminal on a wire network as the line reference value for calculating a reference-based wire number. For example, a wire network starts at line reference 100 and drops down and over on line reference 103. If a schematic terminal symbol carries the WIRENO attribute located on line reference 103, and this option is enabled, AutoCAD Electrical calculates a reference-based wire number using 103 instead of 100. If multiple wire number terminals exist on this network, the line reference value of the upper left-most terminal is used.
<b>Hidden on Wire Network with Terminal Displaying Wire Number</b>	Specifies to hide the wire number automatically for a wire network that has a wire number-type terminal.
<b>On per Wire Basis</b>	Specifies to assign a wire number for each wire rather than the default one wire number per wire network.

**Exclude** If using sequential wire numbers, specifies the wire number ranges to exclude. (applied to the %N part of the wire number tag format)  
Syntax is <starting>-<ending> to show range (for example 1000-1499). Multiple ranges are allowed and must be separated with a comma or semi-colon (for example, 1000-1099;2500-2599;). You can also use 2;4;6 or 2,4,6 for values not in a range.

### New Wire Number Placement

---

**NOTE** The Insert Wire Number tool does not take the current wire number setting (in-line, above or below) into account when updating existing wire numbers. This setting is used only when inserting new wire numbers. Use the Toggle Wire Number In-Line tool for flipping existing wire numbers among the three modes.

---

<b>Above Wire</b>	Places the wire number above the physical wire.
<b>In-Line</b>	Places the wire number in line with the wire.
<b>Gap Setup</b>	Defines spacing between the wire number and the wire itself.
<b>Below Wire</b>	Places the wire number below the physical wire.
<b>Centered</b>	Specifies to insert the wire number tags in the center of each wire segment.
<b>Offset</b>	Specifies to insert the wire number tags the specified offset distance.
<b>Offset Distance</b>	Specifies a fixed, user-defined offset distance from the left or top of the first wire segment found on the wire network.
<b>Leaders</b>	(This option is unavailable for in-line wire numbers) AutoCAD Electrical places wire numbers on leaders when it determines that the wire number text bumps into something (it does not check if the leader itself overlays another object). Select the method for inserting new wire numbers as leaders: As Required, Always, or Never.

---

**NOTE** This change does not affect wire numbers that are already present on the drawing.

---

## Wire Type

Displays the Rename User Columns dialog box used for renaming User1 to User20 header columns in the Set Wire Type, Create/Edit Wire Type, and Change/Convert Wire Type dialog boxes.

## Find or replace wire number text

### Find or replace wire number text

Find and replace wire number text values, or find and replace substrings within those values. Process the active drawing or the project drawing set.

- 1 Click Schematic tab ► Edit Wires/Wire Numbers panel ► Modify Wire



Numbers drop-down ► Find/Replace.

- 2 Specify whether to replace the text only if the entire wire number text string matches the Replace value or to replace the text anywhere within the wire number text string.
- 3 Enter up to three different Find/Replace values, and then click Go.
- 4 Choose to process the project, the current drawing, or selected wire numbers on the current drawing.  
AutoCAD Electrical scans the selection looking for all the AutoCAD Electrical wire number text values and replacing text as instructed.

### Find or replace wire numbers

Edits wire numbers using a find and replace operation.

-  **Ribbon:** Schematic tab ► Edit Wires/Wire Numbers panel ► Modify



Wire Numbers drop-down ► Find/Replace.



-  **Toolbar:** Edit Wire Numbers

-  **Menu:** Wires ► Wire Numbers Miscellaneous ► Find/Replace Wire Numbers

-  **Command entry:** AEFINDWIRENO

Find and replace wire number text values, or find and replace substrings within those values. Process the active drawing or the project drawing set.

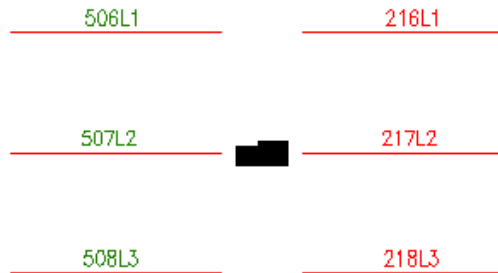

<b>Full, exact match</b>	Specifies to replace the text only if the entire text value matches the find value.
<b>Substring match</b>	Specifies to replace the text if any part of the text value matches the find value.
<b>First occurrence only</b>	Specifies to replace only the first occurrence within the text value.
<b>Find</b>	Specifies the value you wish to find.
<b>Replace</b>	Specifies the text string to replace the find value with.

## Encode wire color/gauge information into wire numbers

### Encode wire color/gauge information into wire numbers

Use the Wire Layer/Format Overrides tool to have wire numbering automatically insert with wire color, gauge, and type information encoded into the wire number itself. For example, you can have wire numbers like 123-RD-14 or 124-BLK-10 instead of 123 or 124.

- 1 Click Project tab ► Project Tools panel ► Manager. 
- 2 In the Project Manager, right-click the project name, and select Properties.

- 3 In the Project Properties dialog box, click the Wire Numbers tab.
- 4 In the Wire Number Options section, select Based on Wire Layer and then click Layer Setup.

The Assign Wire Numbering Formats by Wire Layers dialog box opens. Enter each wire layer name and the wire number format that you want to see for wire numbers on that wire layer. For example, let's say that you routinely use wire layers "RED\_14\_THHN" and "BLK\_10\_XHHN" in drawings in your project. Whenever you have a wire number on the red wire, you want AutoCAD Electrical to append a "-RD-14" suffix automatically to the wire number. For wire numbers generated on wires drawn on layer BLK\_10\_XHHN, you want AutoCAD Electrical to append a "-BLK-10" suffix to the wire number automatically.
- 5 In the Assign Wire Numbering Formats by Wire Layers dialog box, enter RED\_14\_THHN in the Wire Layer Name box and enter %N-RD-14 in the Wire Number Format For Layer box.
- 6 Click Add.
- 7 Enter BLK\_10\_XHHN in the Wire Layer Name box and enter %N-BLK-10 in the Wire Number Format For Layer box. Click Add.
- 8 Repeat until you have all possible wire layers set up.

This information is stored in the project's .wdp file and is applied across all drawings listed in your project.
- 9 Click OK.

Now when you run the Insert Wire Numbers command on any drawing in your project, nonfixed wire numbers update if they are associated with wires that are tagged in your override list.

### **Assign wire numbering formats by wire layers**

The default format of a wire number is defined in the AutoCAD Electrical Project Properties dialog box. This format is used for all wire numbers inserted on a drawing. However, there are times when you want certain types of wires to be numbered in a different way (that is, to carry a different format). AutoCAD Electrical allows you to override the default wire number format by using layer defined formats. For example, your default wire number format is %N. It takes on the line reference number (in Reference Mode) or the sequential number (in Sequential Mode). If there are multiple wire numbers on a particular line reference a suffix is used from the defined suffix list to make the wire number unique.



 **Ribbon:** Schematic tab ► Insert Wires/Wire Numbers panel ► Insert

Wire Numbers drop-down ► Wire Numbers.



 **Toolbar:** Main Electrical 2

 **Menu:** Wires ► Insert Wire Numbers

 **Command entry:** AEWIRENO

Click Use Wire Layer Format Overrides Setup.

---

**NOTE** You can also access this dialog box by selecting Based on Wire Layer and then clicking Layer Setup in the Wire Number Options section of the Project Properties ► Wire Numbers dialog box.

---

<b>Wire list</b>	Lists all defined wire layer formats.
<b>Add</b>	Adds the new wire layer format to the list.
<b>Update</b>	Updates the selected wire layer format with the changes you specified in the dialog box.
<b>Delete</b>	Removes the new wire layer format from the list.
<b>Wire layer name</b>	Specifies the name for the wire layer to modify. Type the layer name or select from the list of valid wire layers. Wild cards are allowed.
<b>List</b>	Displays a list of valid wire layers.
<b>Default</b>	Automatically enters the default value for the format, sequence start, and suffix list fields.
<b>Wire number format for layer</b>	Defines the format override.
<b>Starting wire sequence</b>	Specifies the sequential start number for the layer. Use it if you are using Sequential Mode.
<b>Wire number suffix list for layer</b>	Specifies a unique suffix list. The suffix list must be a comma delimited string. Use it if you are using Reference Mode.

### Replaceable parameters for device tagging and wire numbering

%F	Component family code string (ex: "PB", "SS", "CR", "FLT", "MTR")
%S	Sheet number of the drawing (ex: "01" entered in upper right)
%D	Drawing number
%G	Wire layer name of the drawing
%N	Sequential or Reference-based number applied to the component
%X	Suffix character position for reference-based tagging (not present = end of tag)
%P	IEC-style project code (default for drawing)
%I	IEC-style installation code (default for drawing)
%L	IEC-style location code (default for drawing)
%A	Project drawing list's SEC value for active drawing
%B	Project drawing list's SUB-SEC value for active drawing

---

**NOTE** If you include %I or %L in the Tag code of the component, you are prompted to recalculate the tag if you change the Installation or Location value of the component once it is inserted.

---

## Fix Wire Numbering

### Fix wire numbering

#### Fix a wire number

In some cases, certain wire numbers must be preassigned. They can include motor wiring that must include special suffix values or other wiring, such as instrumentation, that might not follow the default numbering convention. Manually edit the wire number and flip it to fixed. Fixing a wire number means that the wire number tag is left unchanged if later processed or reprocessed by the automatic wire numbering utility.

- 1 Click Schematic tab ► Edit Wires/Wire Numbers panel ► Modify Wire



Numbers drop-down ► Edit Wire Number.

- 2 Select a wire or select an existing wire number. If a wire number exists, the Modify/Fix/Unfix dialog box displays. However, if a wire number does not exist on the selected wire, the Insert Wire Number dialog box displays.

---

**NOTE** If the selected wire is on a layer defined as No Wire Numbering, the Insert Wire Number dialog box does not display. An alert displays indicating that the layer is set as No Wire Numbering.

---

- 3 Edit the wire number or enter a new wire number. If you are inserting a wire number, use the arrows or click Pick to select the appropriate wire number. Pick speeds up the task if you have some special wire numbers to edit manually.
- 4 Select to make the wire number visible or hidden.
- 5 To fix the wire number, select Fixed and click OK. If the wire number is already fixed and you want to turn it back into a regular wire number, clear the check box and click OK.

## Fix all wire numbers

There are times when you want to fix all or many wire numbers on a drawing at their current values. Use the Fix Wire Numbers tool and identify all the wiring you want AutoCAD Electrical to mark as fixed.

If you run a wire number retag later on, fixed wire numbers do not change.



- 1 Click Schematic tab ► Edit Wires/Wire Numbers panel ► Modify Wire



Numbers drop-down ► Fix.

- 2 Select a wire number or component to fix.
- 3 Right-click when you are done selecting the wires. You can check whether the wire is fixed by clicking the Edit Wire Number tool, selecting the wire, and reviewing the dialog box.

### Fix/unfix all wire numbers project-wide

You can quickly fix or unfix all wire numbers across the active project using the Project-Wide Utilities tool.



- 1 Click Project tab ► Project Tools panel ► Utilities.
- 2 In the Project-Wide Utilities dialog box, Wire Numbers section, select Set all wire numbers to fixed or Set all wire numbers to normal, and click OK.
- 3 Select the drawings to process and click OK.

### Modify/fix/unfix

Provides the means to edit a wire number or inserts a new one where none exists.

-  **Ribbon:** Schematic tab ► Edit Wires/Wire Numbers panel ► Modify

Wire Numbers drop-down ► Edit Wire Number.



-  **Toolbar:** Main Electrical 2

-  **Menu:** Wires ► Edit Wire Number

-  **Command entry:** AEEDITWIRENO

Edit Wire Number provides the means to:

- Modify the wire number value

- Fix or unfix the wire number
- Change the visibility of the wire number



When a wire number is fixed, the wire number attribute is renamed and moved to a special fixed wire number layer. Assigning a different color to this layer makes it easy to identify which wire numbers are fixed and which are normal. The layer name for fixed wire numbers is entered in the Define Layers dialog box (from the Drawing Properties ► Drawing Format dialog box).

#### Wire Number

Specifies the wire number to edit. Use the arrows to scroll through possible wire numbers.

If you enter an existing wire number during the insert/edit process, a warning dialog box displays. Turn off the warning in the Project Properties ► Project Settings dialog box. It temporarily disables the warning dialog box for the current session of AutoCAD Electrical). This alerts you of the duplication and suggests alternative wire number based on the user-defined format. You can select whether to use the duplicated wire number, use a new wire number that is suggested, or you can type in a wire number.

---

**NOTE** An error log file is created for every project regardless whether you chose to display a dialog box or not. The warning is saved in the log file named "<project\_name>\_error.log" and is saved in the User subdirectory.

---

#### Pick

Prefills the wire number edit box with the text entity you select. Use Up or Down to quickly increment or decrement the wire number.

<b>Make it Fixed</b>	Fixes the wire number so that it does not change if later processed by the automatic wire numbering utility.
<b>Visible/Hidden</b>	Displays or hides the wire number on the drawing. Hidden wire numbers are still present and appear in wire reports. <b>See also:</b> <a href="#">Erase or hide wire numbers</a> on page 1008
<b>Zoom</b>	Restores the previous screen view. Do a zoom extents to follow an untagged wire that travels off screen.

## Project-wide utilities

Provides the means for operations on wire numbers, component tags, attribute text, wire types, and item numbers. You can define scripts and apply them project-wide.

 **Ribbon:** Project tab > Project Tools panel > Utilities.



 **Toolbar:** Project



 **Menu:** Projects > Project-Wide Utilities

 **Command entry:** AEUTILITIES

Select project drawings and perform any of the following:

- Erase, reset, fix, or unfix wire numbers.
- Fix or unfix component tags.
- Fix or unfix item numbers.
- Clear signal cross-referencing.
- Run a user-specified script file.
- Change attribute text size or style.
- Import wire types from another drawing or drawing template.

You can have multiple drawings open at any time. However, to maximize performance and memory usage, minimize the number of open drawings when running project-wide commands.

### Wire Numbers

Select to keep wire numbers the same, erase specified wire numbers, reset specified wire numbers, or set wire numbers to fixed or normal.

### Signal Arrow Cross-reference text

Select to maintain the signal arrow cross-reference text or to remove all signal arrow cross-reference text across the current project.

### Parent Component Tags: Fix/Unfix

Select to maintain the component tags or to set all parent component tags to fixed or normal across the current project.

### Item Numbers: Fix/Unfix

Select to maintain the item numbers or to set all item numbers to fixed or normal across the current project. If you run [Resequence Item Numbers](#) on page 1602 later on, fixed item numbers do not change.

### Change Attribute

#### Change Attribute Size

Click Setup to select the attributes to change, and then enter the height and width definitions for the selected attributes.

---

**NOTE** If you do not want the attribute height or width to change, do not enter a value definition.

---

#### Change Style

Click Setup to select a text font to apply to the text style used on component attributes.

### For each drawing

Enter the name or browse to a command script file to use for each drawing in the current project or to purge all blocks.

### Wire Types

Imports wire types defined on another drawing or drawing template. Enter the drawing or template name or browse to it using the browse button. The program reads the specified drawing and extracts all wire type information.

Click Setup to display the [Import Wire Types](#) on page 903 dialog box where you:

- Select the wire types to import.
- Define whether to overwrite any Wire Numbering and USERn differences for existing wire types.
- Define whether to overwrite color and linetype differences for existing wire layers.

## Reposition Wire Numbers

### Reposition wire numbers

#### Scoot wire numbers

If you want to move a wire number along its wire segment, use Scoot and pick right on the wire number.

- 1 Click Schematic tab ► Edit Components panel ► Modify Components



drop-down ► Scoot.

- 2 Select the wire number to slide along its connected wires or select the wire segment itself to scoot the entire wire, including the components, along the bus. You can scoot an entire rung up or down. A rectangle drawn in temporary graphics indicates the selected items.
- 3 Move your cursor to the appropriate position and click your mouse button.

The items scoot and reconnect.

#### Move a wire number

Moves an existing wire number to a selected location on the same wire network.

Select a location on the wire segment to define a new position for the wire number.



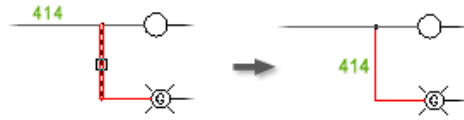

- 1 Click Schematic tab ► Edit Wires/Wire Numbers panel ► Move Wire



Number.

- 2 Select the wire segment where you want the wire number repositioned. It is not required that you pick on the existing wire number first. The wire number automatically moves to the selected position.

### Rotate a wire number

- 1 Click Schematic tab ► Edit Components panel ► Modify Attributes



drop-down ► Rotate Attribute.

- 2 Select the wire number text to rotate 90 degrees from its current orientation. Each click the wire number text rotates it another 90 degrees counter-clockwise.

### Reposition the wire number text with an attached leader

Inserts, modifies, or collapses a leader on a selected wire number.

Pick directly on the wire number text, and then identify the new position. Right click or press Enter to exit the command.

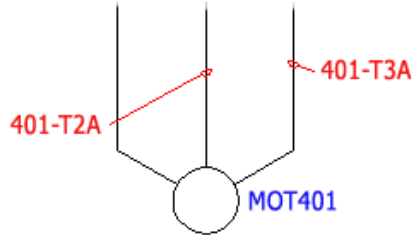

- 1 Click Schematic tab ► Insert Wires/Wire Numbers panel ► Wire

Number Leader drop-down ► Wire Number Leader.



- 2 Select the wire number text.
- 3 Select the new position for the wire number. Right-click or press Enter to position the wire number.

---

**NOTE** You can type "C" at the command prompt to collapse the wire leader back to the wire number block. You can do it immediately after inserting a leader if you determine that you do not want the leader. Or, rerun the command if you want to remove the leader from existing wire numbers.

---

## Move the wire number without use of a leader

If you want to reposition the wire number without use of a leader, use the Move Attribute utility.

- 1 Click Schematic tab ► Edit Components panel ► Modify Attributes

drop-down ► Move/Show Attribute.



- 2 Select the attributes to move and press Enter.  
You can pick the components individually or by windowing. Each attribute highlights with a rectangular box drawn around it.
- 3 Select the base and insertion points for the move. The attribute follows your cursor and is automatically moved to the selected position.  
The attributes remain tied to the parent block inserts.

---

**NOTE** Avoid using the AutoCAD MOVE command to reposition a wire number. An AutoCAD Electrical smart wire number is an invisible block with one visible wire number attribute associated with it. The X-Y insertion point of the block must physically lie on the wire segment. If it is forced off the segment during an AutoCAD MOVE command, then AutoCAD Electrical no longer sees it linked to the wire. To use straight AutoCAD commands to reposition a wire number, use GRIPS to move the wire number attribute or any other attribute position editing command. You reposition the wire number attribute but not its underlying block insertion point.

---

## Swap wire numbers

Swaps two wire numbers on separate wire networks.

Select the two wire networks, or pick the existing wire number text.



- 1 Click Schematic tab ► Edit Wires/Wire Numbers panel ► Modify Wire

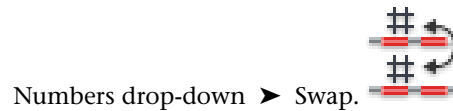

- 2 Select the first wire or number and then select the second wire or number.  
The wire numbers automatically switch positions.

## Copy wire numbers

Inserts an extra copy of a wire number.

A copy of a wire number follows the main wire number of a network. You can position the copy anywhere on a wire network. If AutoCAD Electrical modifies a main wire number, the copies of the wire number update as well. Extra wire numbers go on the Wire Copies layer defined in the drawing properties.



- 1 Click Schematic tab ► Edit Wires/Wire Numbers panel ► Copy Wire



Number drop-down ► Copy Wire Number.

- 2 Select the wire location where you want the extra wire number to insert.

### Position wire numbers in-line with the wire

Inserts an extra copy of a wire number in-line at a pick point.

Positions wire numbers in-line with the wire rather than above or below the wire.

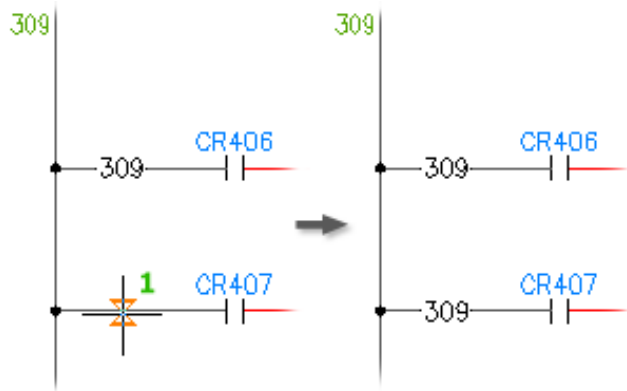

- 1 Click Schematic tab ► Edit Wires/Wire Numbers panel ► Copy Wire



Number drop-down ► Copy Wire Number In-line.

- 2 Specify the insertion point for the wire number.
- 3 In the Insert Wire Number dialog box, enter the wire number. Use Pick to select similar text from the drawing, or click the arrows to increment or decrement the wire number.
- 4 Click OK. The wire number is automatically inserted in-line with the wire.  
If the gap between the wire and the wire number text is not large enough you can change the gap setup.

- 5 Click Schematic tab ► Edit Wires/Wire Numbers panel ► Copy Wire



Number drop-down ► Adjust In-Line Wire/Label Gap.

- 6 Type S and press Enter to open the In-Line Wire Label Gap Setup dialog box.
- 7 Adjust the values as necessary to define the adjustment for the gap size.
  - A: Specifies the width between the end of the wire and the text. The second option for setting "A" is the snap setting for the width. The width stays constant until the text grows to a point where the Text + A + A gets past the current gap width in the wire. The gap width then jumps up to the next snap width increment. If this second value is set to 0.25, the gaps in the wires are always going to be at 0.25 increments (0.25, 0.5, 0.75, 1.0). If this middle value is left at 0.0, then the snap distance is 0 and the gap in the wire grows or shrinks smoothly as the wire text grows or shrinks.
  - C: Specifies the minimum gap width by setting a fixed size value. If you want fixed spacing for the in-line wire number gap, enter a size value in the C edit box. A non-blank C value gives the minimum gap width even if the wire number is a single character or was blanked out.

The gap is adjusted for the selected wire number.

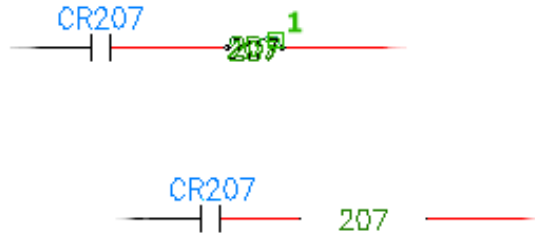

### Mirror a wire number

Moves a selected wire number to the same position on the other side of the wire.

Select each wire number to flip.

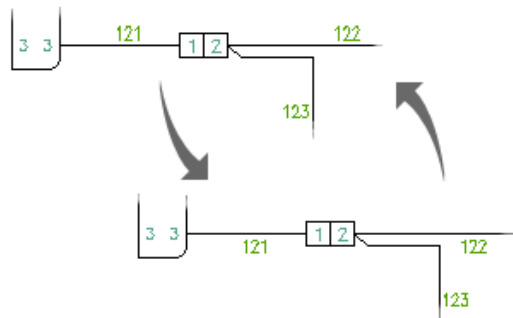

- 1 Click Schematic tab ► Edit Wires/Wire Numbers panel ► Flip Wire

Number. 

- 2 Select the wire number to mirror.  
Each wire number selected is mirrored across its associated wire.

---

**TIP** Use the Toggle Wire Number In-Line tool to move a wire number from above/below the wire to in-line. If the wire number is already in-line, the wire number moves to the position defined in the [Drawing properties: wire numbers tab](#) on page 225.

---

## Toggle wire number position

Switches a wire number between drawing properties above or below and in-line.

If the wire number you select is in-line, it switches to above or below based on the drawing properties. If it starts as above or below, the selected wire number switches to in-line.



---

**NOTE** If there is not room for a wire number to become an in-line wire number, it remains an above or below line wire number.

---

**TIP** Use the Flip Wire Number tool to switch a wire number between above and below the wire.

---

- 1 Click Schematic tab ► Edit Wires/Wire Numbers panel ► Toggle Wire





Number In-line.

- 2 Select the wire number to toggle. You can select on the wire number or on the wire itself.
- 3 Right-click to exit the command.

Apply drawing-specific wire number settings. These settings are maintained inside the WD\_M block in the drawing.

### Any drawing

 **Ribbon:** Project tab ► Project Tools panel ► Manager. 

 **Toolbar:** Main Electrical 2 

 **Menu:** Projects ► Project Manager

 **Command entry:** AEPROJECT

In the Project Manager, right-click the drawing name, and select Properties ► Drawing Properties. Select the Wire Numbers tab.

### Active drawing

 **Ribbon:** Schematic tab ► Other Tools panel ► Drawing Properties

drop-down ► Drawing Properties. 

 **Toolbar:** Main Electrical 2 

 **Menu:** Projects ► Drawing Properties

 **Command entry:** AEPROPERTIES

Select the Wire Numbers tab.

### Wire Number Format

Wire number tags can be sequential or reference-based.

#### Format

Specifies the way new wire number tags are created. The wire number tag format must include the %N parameter that is the base sequential or reference-based value per the selection above. If your format includes the sheet number %S parameter or the drawing number %D parameter, enter the values in the edit boxes in the Drawing Properties ► Drawing Settings dialog box.



---

**NOTE** For reference-based wire number tagging, individual items in the suffix list are applied to the wire tags to keep multiple wires in the same reference location unique. These values are added to the end of the tag, but you can force AutoCAD Electrical to insert the suffix character somewhere within the tag format. Use the Suffix position parameter, %X, in the component tag format (for example, %X%N).

---

**Search for PLC I/O address on insert** Specifies to use PLC I/O address values for wires that connect to an addressed I/O point. This setting overrides both Sequential and Reference-based tagging. New wires or wire renumbering on the current drawing shows PLC I/O address-based wire numbers automatically.

---

**NOTE** Like component tags, AutoCAD Electrical uses the concept of a wire tag format string with replaceable parameters. The %N parameter must always be part of the wire format string. A typical format string can be just this %N parameter.

---

**Sequential** Enter the starting sequential number (alpha, numeric, or alphanumeric) for the drawing. If you enter the same starting sequential number for every drawing of your wiring diagram set, AutoCAD Electrical confirms at insertion time that a new sequential wire number tag is not repeated on any other drawing.

If you set DEMO1 to 100 and DEMO2 to 200, the wire numbers on DEMO1 start at 100 and wire numbers on DEMO2 start at 200. If DEMO1 has more than 100 wire numbers it starts using wire number 200 and above. DEMO2 would begin its wire numbers where DEMO1 left off (making sure that duplicate wire numbers are not assigned).

**Increment** The default is "1." Setting it to "2" with a starting sequential of "1" would yield wire numbers 1, 3, 5, 7, 9, 11, and so on.

**Line Reference** Sets the wire number tag suffix. This list is used to create unique reference-based wire number tags for multiple wire networks beginning at the same reference location (such as wire network beginning at a location per line reference number, X-Y grid reference, or X-Zone reference).

**Suffix Setup** Displays a suffix list. List suffix characters for wire numbers beginning on the same line reference or in the same zone (to keep wire numbers unique). Select one of the four predefined suffix lists or enter your own custom suffix list.

### **New Wire Number Placement**

---

**NOTE** The Insert Wire Number tool does not take the current wire number setting (in-line, above or below) into account when updating existing wire numbers. This setting is used only when inserting new wire numbers. Use the Toggle Wire Number In-Line tool for flipping existing wire numbers among the three modes.

---

<b>Above Wire</b>	Places the wire number above the physical wire.
<b>In-Line</b>	Places the wire number inline with the wire.
<b>Gap Setup</b>	Defines spacing between the inline wire number and the wire itself.
<b>Below Wire</b>	Places the wire number below the physical wire.
<b>Offset</b>	Specifies to insert the wire number tags the specified offset distance.
<b>Centered</b>	Specifies to insert the wire number tags in the center of each wire segment.
<b>Offset Distance</b>	Specifies a fixed, user-defined offset distance from the left or top of the first wire segment found on the wire network.
<b>Leaders</b>	(This option is unavailable for in-line wire numbers.) AutoCAD Electrical places wire numbers on leaders when it determines that the wire number text bumps into something. It does not check if the leader itself overlays another object. Select the method for inserting new wire numbers as leaders: As Required, Always, or Never.

---

**NOTE** This change does not affect wire numbers that are already present on the drawing.

---

# Modify Wire Numbers

## Modify wire numbers

### Increment wire numbers

You can force new incremental wire numbers (as opposed to line referenced numbers) to increment by more than one during insertion.

- 1 Click Schematic tab ► Other Tools panel ► Drawing Properties



drop-down ► Drawing Properties.

- 2 Click the Wire Numbers tab.
- 3 In the Wire Number Format section, select Sequential and set the increment value.
- 4 (Optional) For this increment value to be your standard for all new drawings, follow the same procedure in the Project Properties ► Wire Numbers dialog box.

---

**NOTE** You can also do it by creating an electrical template drawing with the wd\_m block pre-inserted and the increment value pre-assigned.

---

### Change the default wire number size

You must change several block inserts in each of the symbol libraries you use. The wire number block drawings to adjust are: wd\_wnh.dwg (horizontal wire number), wd\_wnv.dwg (vertical wire number), wd\_wch.dwg (horizontal extra wire number copy), and wd\_wcv.dwg (vertical extra wire number copy). You can find them in your AutoCAD Electrical symbol library.

- **Windows XP:** C:\Documents and Settings\All Users\Documents\Autodesk\Acade {version}\Libs\{library}\
- **Windows Vista, Windows 7:** C:\Users\Public\Documents\Autodesk\Acade {version}\Libs\{library}\

- 1 Determine which schematic symbol library is in use and open drawing "wd\_wnh.dwg" in AutoCAD.

- 2 Change the text size of the WIRENO attribute definition.
- 3 Save the drawing.
- 4 Open drawings "wd\_wnv.dwg", "wd\_wch.dwg", and "wd\_wcv.dwg."
- 5 Repeat steps 2 and 3 for each.

---

**NOTE** You will not see these new, resized wire numbers on existing drawings unless you erase all the wire numbers and purge the drawing of the old block inserts.

---

### **Make wire numbers on vertical wires come in rotated 90 degrees**

You can make wire numbers for vertical wires come in automatically rotated 90 degrees so the wire number lays along the wire.

- 1 Determine which schematic symbol library is in use and open drawing "wd\_wnv.dwg" in AutoCAD.
- 2 Rotate the WIRENO attribute 90 degrees using the AutoCAD Rotate command.
- 3 Save the drawing.
- 4 Open drawing "wd\_wcv.dwg."
- 5 Repeat steps 2 and 3.

## **Erase or Hide Wire Numbers**

### **Erase or hide wire numbers**

#### **Erase or hide wire numbers**

##### **Erase a wire number**

Deletes selected wire numbers.

Deletes the main wire number of a network, or a wire number copy. Select a wire number copy precisely to erase just that copy, leaving the main wire number of the network and any other copies in place. Select the main wire number to delete it and all wire number copies.

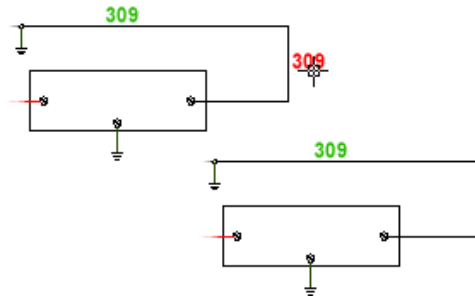

- 1 Click Schematic tab ► Edit Wires/Wire Numbers panel ► Delete Wire



Numbers.

- 2 Select the wire number or pick on any wire in the network.
- 3 Press Enter. The wire number is automatically deleted. Extra wire number copies can also be deleted.

### Erase all wire numbers project-wide



- 1 Click Project tab ► Project Tools panel ► Utilities.
- 2 Select to remove all wire numbers or keep fixed wire numbers and click OK.
- 3 Select which drawings you want to process and click OK.  
The selected drawings are processed and the wire numbers change across the project.

### Hide/unhide wire numbers

#### Hide wire numbers

AutoCAD Electrical automatically hides wire numbers when the wire number is on the same network as a terminal symbol that carries a copy of the wire number (WIRENO attribute). You can hide or show wire numbers manually.

- 1 Click Schematic tab ► Edit Wires/Wire Numbers panel ► Modify Wire



Numbers drop-down ► Hide.

- 2 Select a wire number or the wire it is associated to. AutoCAD Electrical moves the wire number to a special hide layer and the number is no longer visible on the screen.

The new hide layer is created from the wire number layer name with a "\_HIDE" suffix. For example, if the wire number text layer is called WIRENO then the hide layer name is called "WIRENO\_HIDE". The layer is created automatically when needed and you are asked if you want to freeze this layer.

#### Unhide wire numbers

- 1 Click Schematic tab ► Edit Wires/Wire Numbers panel ► Modify Wire



Numbers drop-down ► Unhide.

- 2 Select a wire number or the wire the hidden number is associated to. AutoCAD Electrical moves the wire number out of the hide layer and the number is visible on the screen.

---

**NOTE** Do not use the Hide Wire Number and Unhide Wire Number tools on in-line wire numbers.

---

#### See also:

- [Modify/fix/unfix](#) on page 992

## Signal Arrows

### Signal Arrows

AutoCAD Electrical uses a named source/destination concept. You identify a wire network to be the source, insert a source arrow on that network, and assign a source code name to it. On the wire network that is to be a

continuation of the same wire number, whether on the same drawing or a different drawing in the project, insert a destination arrow. Give it the same code name that you gave to its source. AutoCAD Electrical matches source code names with destination names and copies source wire numbers over to the destination wire networks.

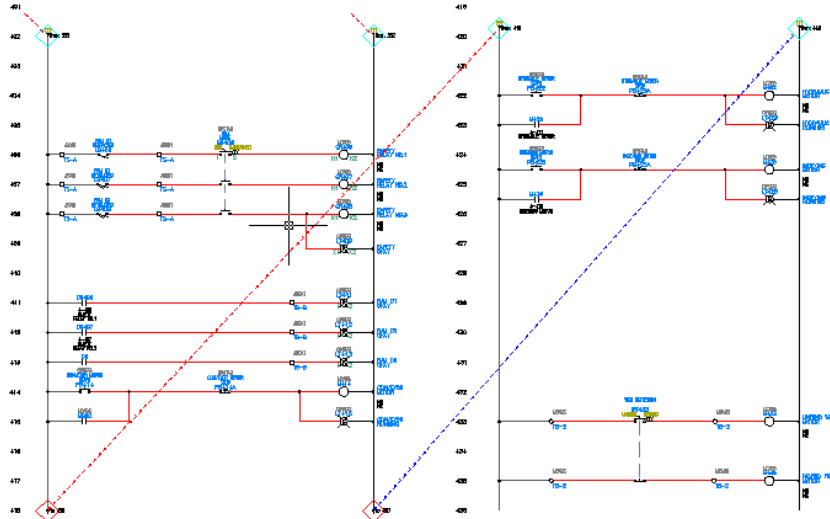

## Add custom signal arrow styles

The icon menu graphics that display for the various signal styles are bitmap files saved to your C:\Program Files [(x86)]\Autodesk\Acade {version}\Acade\ folder where AutoCAD Electrical's Insert Signal utilities and Drawing Properties tool can access them.

- 1 Create the style in AutoCAD.
- 2 Zoom in to the new arrow style.
- 3 Save the file as a bitmap using the following name definition:  
A\_STYLEExh.bmp where "x" is the arrow style 1-9.

---

**NOTE** If the resulting bitmap is too small or off-center, open the source drawing in AutoCAD again. Resize your AutoCAD graphics window so that it is more square. Center the image and resave. Repeat until you are satisfied with the result.

---

## Modify signal arrow prefix

When a source or destination signal arrow is inserted it is cross-referenced. The source arrow has the reference for the destination arrow. The destination arrow has the reference for the source arrow. The cross-reference text can carry a prefix, for example “to” on a source arrow and “from” on a destination arrow. This prefix value is defined on the signal arrow library symbol. You can change the prefix by modifying the library symbol.

- 1 Open the signal arrow library symbol.  
See [Source/Destination Wire Signal Arrow Symbols](#) on page 293 to determine the name of the signal arrow you want to modify.
- 2 Enter DDEDIT at the command line.
- 3 Click the XREF attribute.
- 4 Edit the Prompt value.
- 5 Click OK.
- 6 Save the symbol.

---

**NOTE** Purge existing drawings of this symbol before inserting this modified symbol.

---

## Insert destination code

Inserts a wire Destination signal arrow with a wire number from a matching Source.

 **Ribbon:** Schematic tab ► Insert Wires/Wire Numbers panel ► Signal

Arrows drop-down ► Destination Arrow. 

 **Toolbar:** Signals

 **Menu:** Wires ► Signal References ► Destination Signal Arrow

 **Command entry:** AEDESTINATION

The program retrieves the wire number for a destination-arrowed wire network from its associated source-arrowed wire network. Enter the same number, word, or phrase the source arrow carries to link to it.



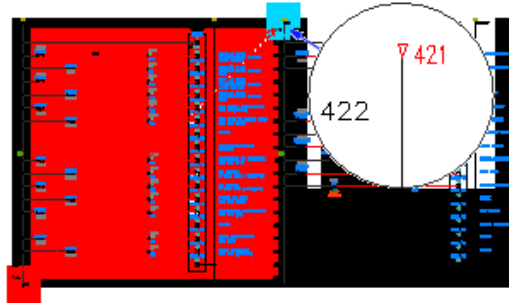

---

**NOTE** A Destination signal arrow cannot be tied to a wire network that carries a pre-assigned fixed wire number.

---

<b>Code</b>	Specifies the code for the destination signal. Enter a unique number/word/phrase, 32-character maximum, for AutoCAD Electrical to use to link the destination wire network internally to any source wire networks.
<b>Description</b>	(optional) Specifies the description for the destination signal.
<b>Defaults</b>	Opens an ASCII text file from which you can quickly pick standard descriptions.
<b>Recent</b>	Picks from recently inserted codes.
<b>Drawing</b>	Displays drawing-wide pick lists of all source/destination codes used so far.
<b>Project</b>	Displays project-wide pick lists of all source/destination codes used so far.
<b>Pick</b>	Picks on an existing wire network. AutoCAD Electrical searches it for an existing source arrow and retrieves its signal code for use on this new destination arrow.
<b>Signal Arrow Style</b>	Specifies the arrow style to use for the destination signal. There are currently nine styles to choose from.
<b>Ok + Update Source</b>	Finishes the destination arrow insert and updates the source arrow with this destination arrow.

## Signal - source code

Inserts a wire Source signal arrow and transfers its wire number to destination wire networks.

 **Ribbon:** Schematic tab ► Insert Wires/Wire Numbers panel ► Signal

Arrows drop-down ► Source Arrow.

 **Toolbar:** Main Electrical 2

 **Menu:** Wires ► Signal References ► Source Signal Arrow

 **Command entry:** AESOURCE

The wire number from a source-arrowed wire network copies to all associated destination-arrowed wire networks. Enter a unique number, word, or phrase of 32 characters maximum to link the source wire network to all destination wire networks internally.

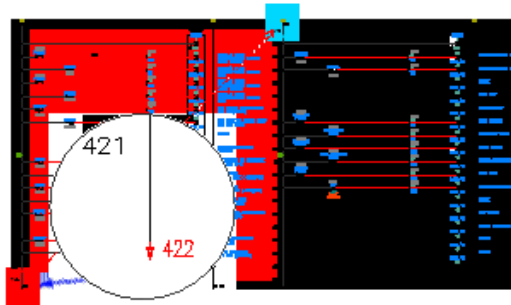



<b>Code</b>	Specifies the code for the source signal. Enter a unique number/word/phrase, 32-character maximum, for AutoCAD Electrical to use to link the source wire network internally to any destination wire networks.
<b>Use</b>	Places the specified value into the code box. It is useful for using the next number in a sequence.
<b>Description</b>	(optional) Specifies the description for the source signal.

<b>Defaults</b>	Opens an ASCII text file from which you can quickly pick standard descriptions.
<b>Recent</b>	Picks from recently inserted codes.
<b>Drawing</b>	Displays drawing-wide pick lists of all source/destination codes used so far.
<b>Project</b>	Displays project-wide pick lists of all source/destination codes used so far.
<b>Search</b>	Follows the selected wire network looking for a destination arrow at the other end. If found, repeat its signal code for this new source arrow.
<b>Pick</b>	Picks on an existing wire network. AutoCAD Electrical searches it for an existing destination arrow and retrieves its signal code for use on this new source arrow.
<b>Signal Arrow Style</b>	Specifies the arrow style to use for the source signal. Select from the four predefined styles or a user-defined style.
<b>OK + Update Destination</b>	Finishes the source arrow insert and updates the destination arrow with this source arrow.

## Project properties: styles tab

Modify your project default settings for various component styles. All information defined in this tab is saved to the project definition file as project defaults and settings.

 **Ribbon:** Project tab ► Project Tools panel ► Manager. 

 **Toolbar:** Main Electrical 2 

 **Menu:** Projects ► Project ► Project Manager

 **Command entry:** AEPROJECT

In the Project Manager, right-click on the project name and select Properties. Select the Styles tab.

<b>Arrow Style</b>	Specifies the default wire signal arrow style. Select from the four predefined styles or a user-defined style. You can override the default style setting at insertion time. <hr/> <b>TIP</b> For instructions on how to add custom wire arrow styles, see <a href="#">Add custom signal arrow styles</a> on page 1011.
<b>PLC Style</b>	Specifies the default PLC module style. Select from the five predefined styles or a user-defined style. <hr/> <b>TIP</b> For instructions on how to add custom PLC module styles, see <a href="#">Add a new PLC style</a> on page 624.
<b>Fan-In/Out Marker Style</b>	Defines the default Fan In/Out marker style and the layers for wires going out of a Fan In/Out Source marker and those coming into a Destination marker. <hr/> <b>TIP</b> For instructions on how to add custom Fan-In/Out marker styles, see <a href="#">Add custom fan-in/out marker styles</a> on page 1023.
<b>Layer List</b>	Lists the Fan In/Out layers.
<b>Add</b>	Defines layer names as Fan In/Out layers.
<b>Remove</b>	Removes the selected layer from the defined layer list.
<b>Wire Cross</b>	Specifies the default mode of operation when wires cross each other: insert gap with no loop, insert gap and loop, or solid (no gap).
<b>Wire Tee</b>	Specifies the default wire tee marker: none, dot, angle1, or angle2.

## **Drawing properties: styles tab**

Apply drawing-specific component styles settings. These settings are maintained inside the WD\_M block in the drawing.

### Any drawing

 **Ribbon:** Project tab ► Project Tools panel ► Manager.



 **Toolbar:** Main Electrical 2



 **Menu:** Projects ► Project Manager

 **Command entry:** AEPROJECT

In the Project Manager, right-click the drawing name, and select Properties ► Drawing Properties. Select the Styles tab.

### Active drawing

 **Ribbon:** Schematic tab ► Other Tools panel ► Drawing Properties

drop-down ► Drawing Properties.



 **Toolbar:** Main Electrical 2



 **Menu:** Projects ► Drawing Properties

 **Command entry:** AEPROPERTIES

Select the Styles tab.

### Arrow Style

Specifies the default wire signal arrow style. Select from the four predefined styles or a user-defined style. You can override the default style setting at insertion time.

---

**TIP** For instructions on how to add custom wire arrow styles, see [Add custom signal arrow styles](#) on page 1011.

---

### PLC Style

Specifies the default PLC module style. Select from the five predefined styles or a user-defined style.

---



**TIP** For instructions on how to add custom PLC module styles, see [Add a new PLC style](#) on page 624.

---

<b>Fan-In/Out Marker Style</b>	Defines the default Fan In/Out marker style and the layers for wires going out of a Fan In/Out Source marker and those coming into a Destination marker. <hr/> <b>TIP</b> For instructions on how to add custom Fan-In/Out marker styles, see <a href="#">Add custom fan-in/out marker styles</a> on page 1023.
<b>Layer List</b>	Lists the Fan In/Out layers.
<b>Add</b>	Defines layer names as Fan In/Out layers.
<b>Remove</b>	Removes the selected layer from the defined layer list.
<b>Wire Cross</b>	Specifies the default mode of operation when wires cross each other: insert gap with no loop, insert gap, and loop, or solid (no gap).
<b>Wire Tee</b>	Specifies the default wire tee marker: none, dot, angle1, or angle2.

## Wire signal or stand-alone reference report

There are two types of reports that can be generated: one on wire signal source/destination codes and one on stand-alone reference codes.

 **Ribbon:** Reports tab ► Schematic panel ► Signal Error/List. 

 **Toolbar:** Signals 

 **Menu:** Wires ► Signal References ► Signal Error/List Report

 **Command entry:** AESIGNALERRORREPORT

<b>Wire Signal Source/Destination codes report</b>	Runs a report that lists all the signal source and destinations used on the project drawing set. The exception report lists problem areas such as a destination signal with no source found or a source signal that does not tie to a destination. Click Format on the subdialog box to select from a listing of report settings files found that have a prefix equal to the selected report type.
--	---

<b>Stand-alone Reference Source/Destination codes report</b>	Runs a report that lists all the stand-alone source and destinations used on the project drawing set. The exception report lists problem areas such as a destination reference with no source found or a source reference that does not tie to a destination. Click Format on the subdialog to select from a listing of report settings files found that have a prefix equal to the selected report type.
<b>Surf</b>	Continues surfing on problems related to the selected report.

## Fan In/Out Markers

### Fan In/Out Source and Destination Markers

There are times when you want to show source and destination markers on the individual wires of a cable, but you want to show the wires coming together to form the cable.

When a Fan In/Out marker is inserted, AutoCAD Electrical breaks the wire and changes the layer of one side of the wire to a special layer. If you are inserting a source marker, then the wire coming out of the marker is changed. If it is a destination marker, the wire coming into the marker is changed. You can use the AutoCAD Electrical Fan In/Out - Single Line Layer command to change a wire to one of these layers.

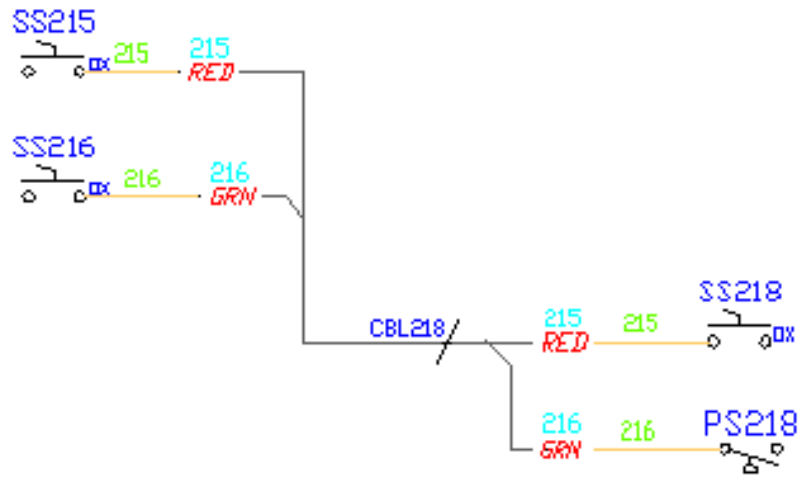

## Add source markers

- 1 Click Schematic tab ► Insert Wires/Wire Numbers panel ► Signal



Arrows drop-down ► Fan In Source.

- 2 Select the style and orientation for the markers and click OK.
- 3 Select the insertion point on the screen for the marker.  
The Signal-Source Code dialog box displays.
- 4 Enter a source code for the marker and optionally a description. Enter a unique number/word/phrase, 32-character maximum, for AutoCAD Electrical to use to link the source wire network internally to any/all destination wire networks.
- 5 Select how you want to view the signal codes used so far:
  - Display drawing-wide or project-wide pick lists of all source/destination codes used so far
  - Follow the selected wire network looking for a destination arrow at the other end. If found, repeat its signal code for this new source arrow.



- Pick on an existing wire network. AutoCAD Electrical searches it for an existing destination arrow and retrieves its signal code for use on this new source arrow.

6 Specify the arrow style to use for the destination signal.

7 Click OK.

The Source/Destination Signal Markers (for Fan In/Out) dialog box displays. You have a few options for inserting the matching destination marker:

- Do not insert the matching destination marker.
- Do not insert the matching destination marker after each source.
- Insert the matching destination marker.
- Automatically insert the matching destination markers for each source.

---

**NOTE** If the destination wires are nearby it may be easiest to insert them right away. If they are on another drawing you can wait until later to insert them.

---

### Add destination markers

1 Click Schematic tab ► Insert Wires/Wire Numbers panel ► Signal



Arrows drop-down ► Fan Out Destination.

2 Select the style and orientation for the markers and click OK.

3 Select the wire for the destination marker.

The Insert Destination Code dialog box displays.

4 Enter the code or select Recent to see a list of the recent markers inserted.

5 Specify the arrow style to use for the destination signal.

6 Continue selecting wires until all destination markers were inserted.

### Set marker styles and layers

The AutoCAD Electrical Fan In/Out feature relies on layering to work. You can select the default Fan In/Out marker style here along with defining the layers for the wires.

- 1 Click Schematic tab ► Other Tools panel ► Drawing Properties



drop-down ► Drawing Properties.

- 2 In the Drawing Properties dialog box, click the Style tab.  
If you have an older drawing, you may be warned about an older version of the WD\_M block. If that happens, go ahead and swap the WD\_M block and try again.
- 3 In the Fan-In/Out Marker Style section, set the default marker style.
- 4 Define the layers for the wires. Click Add to define layer names as Fan In/Out layers.
- 5 Click OK.

## Define fan-in/out layers

You can define a special layer or set of layers for the wires going out of a Fan In/Out Source marker and the wires coming into a Destination marker.

- 1 Click Schematic tab ► Edit Wires/Wire Numbers panel ►  ►



Fan In/Out - Single line Layer.

The list displays only layers that are already assigned as Fan In/Out Layers as defined in the drawing properties setup.

- 2 Use Pick if you are not sure of the layer you want, but you have a line on your drawing on that layer. You can also use it if the layer of the line is not defined as a Fan In/Out layer and you want to add it on the fly.
- 3 Select whether to make the layer current.
- 4 Check the box to change the existing fan in/out lines if you want to make sure that you only change the layers of wires that are already defined as Fan In/Out wires. Otherwise AutoCAD Electrical can convert any selected lines to the Fan In/Out layer.

## Add custom fan-in/out marker styles

The icon menu graphics that display for the various Fan In/Out marker styles are bitmap files saved to your C:\Program Files [(x86)]\Autodesk\Acade {version}\Acade\ folder where s Fan In/Out utilities and Drawing Properties tool can access them.

- 1 Create the style in AutoCAD.
- 2 Zoom in to the new Fan In/Out marker style.
- 3 Save the file as a bitmap using the following name definition:  
StylexVI.bmp and StylexVO.bmp where "x" is the fan-in/out marker style 1-9.

---

**NOTE** If the resulting bitmap is too small or off-center, open the source drawing in AutoCAD again. Resize your AutoCAD graphics window so that it is more square. Center the image and resave. Repeat until you are satisfied with the result.

---

## Fan-in/fan-out signal source

Inserts an in-line, fan in/out source marker.

 **Ribbon:** Schematic tab ► Insert Wires/Wire Numbers panel ► Signal

Arrows drop-down ► Fan In Source.

 **Toolbar:** Signals

 **Menu:** Wires ► Signal References ► Fan In/Out Source

 **Command entry:** AEFANINSRC

Show source and destination markers on the individual wires of a cable, but show the wires coming together to form the cable.

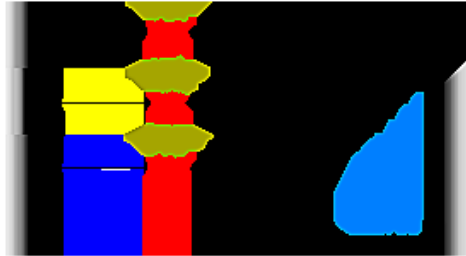

Uses set of in-line source/destination symbols that follow the naming format of ha#s?\_inline.dwg and ha#d?\_inline.dwg where # = style number and ? = 1,2,3,4 orientation number (just like with existing source/destination arrows). Running new commands inserts in-line source marker symbols and changes the connected wire on the fan-in side to be on a non-wire layer. Putting matching destination in-line markers at the fan-out end does the same. It changes the connected common wires on the fan-out side to a non-wire layer. It leaves the individual segments on the opposite side of marker on the original wire layer. The AutoCAD Electrical source/destination update or Auto Wire Number command then makes the match-up annotation, whether the fan-in/fan-out are on the same or different drawings.



<b>Source marker style</b>	Specifies the style for the source marker. Some options are: Solid (wire num/desc), Break (wire num - small gap/desc), Break (medium gap/desc), and Break (wide gap/desc).
<b>Wire connection orientation</b>	Specifies the orientation for the markers. Options are: above, below, right, or left.

### Fan-in/fan-out signal destination

Inserts an in-line, fan in/out destination marker.

 **Ribbon:** Schematic tab ► Insert Wires/Wire Numbers panel ► Signal

Arrows drop-down ► Fan Out Destination.

 **Toolbar:** Signals 



 **Menu:** Wires ► Signal References ► Fan In/Out Destination

 **Command entry:** AEFANINDEST

Show source and destination markers on the individual wires of a cable, but show the wires coming together to form the cable.



Uses set of in-line source/destination symbols that follow the naming format of ha#s?\_inline.dwg and ha#d?\_inline.dwg where # = style number and ? = 1,2,3,4 orientation number (just like with existing source/destination arrows). Running new commands inserts in-line source marker symbols and changes connected wire on the fan-in side to be on a non-wire layer. Putting matching destination in-line markers at the fan-out end does the same. It changes the connected common wires on the fan-out side to non-wire layer. It leaves the individual segments on the opposite side of marker on the original wire layer. The AutoCAD Electrical source/destination update or Automatic Wire Number command then makes the match-up annotation, whether the fan-in/fan-out are on the same or different drawings.

**Destination marker style**

Specifies the style for the destination marker. Some options are: Solid (wire num/desc), Break (wire num - small gap/desc), Break (medium gap/desc), and Break (wide gap/desc).

**Wire connection orientation**

Specifies the orientation for the markers. Options are: above, below, right, or left.

### **Fan-in/out - single line layer**

You can define a special layer or set of layers for the wires going out of a Fan In/Out source marker and the wires coming into a destination marker.

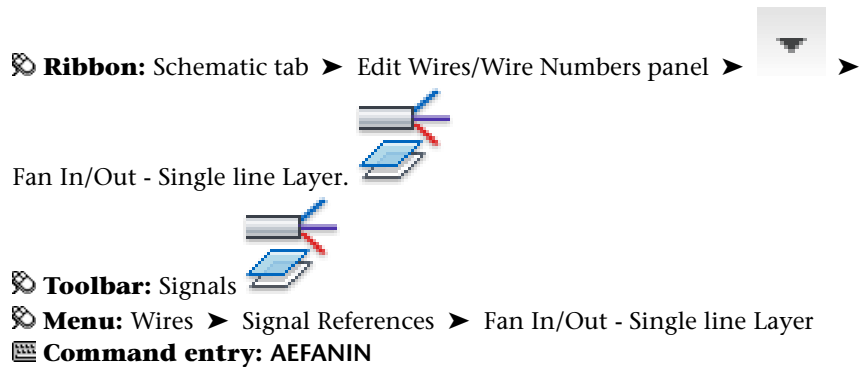

<b>Fan-In/Out Line Layers</b>	Displays only layers that are already assigned as Fan In/Out Layers as defined in the drawing properties setup.
<b>Pick</b>	Picks similar fan-in/out lines from the drawing. You can use it if the layer of the line is not defined as a Fan In/Out layer and you want to add it on the fly.
<b>Change existing wires only (no convert)</b>	Changes only the layers of wires that are already defined as Fan In/Out wires. Otherwise AutoCAD Electrical can convert any selected lines to the Fan In/Out layer.
<b>One pick gets all connected wires</b>	Changes all the wires to the selected layer that is associated with the selected wire network. If this option is not selected, only the selected wire changes.
<b>Make selected layer current</b>	Makes the selected layer the current layer.

## Wire Sequencing

### Control from/to report connection sequencing

A wire network consisting of three or more interconnected components introduces potential unknowns into a from/to connection report. Does A connect to B and then jumper to C or does C connect to A and jumper to B? By default, AutoCAD Electrical reports from/to connections on a single network by first grouping devices by common Location codes and sequentially reports

the inter-wiring of each group. It then ties each common Location group with a single from/to wire connection. For wire connections with the same Location group (or if all devices have the same Location value or no Location value), AutoCAD Electrical attempts to sort the wire connections by physical location on the drawing and report the from/to connections in that order.

---

**NOTE** You can keep jumpers from displaying in Wire From/To reports by placing the jumpers on a layer that contains the substring "JUMPER."

---

AutoCAD Electrical provides several methods to more specifically define wire connection sequencing.

---

**NOTE** You can run one or more sequencing methods simultaneously, even in the same wire network, since there is a hierarchy of which methods take precedence over others.

---

### **Angled Tee Wire Connection Method**

The use of angled tee wire connections can influence the wire connection sequence reporting. The orientation of the tee symbol defines the sequencing. Each symbol carries attribute WDWSEQ with a three-digit value indicating the preferred wire sequencing order. The 90-degree turn or the straight-through section (depending on the style of the angled tee symbol) indicates the beginning of the sequence. The 45-degree turn is the secondary connection. AutoCAD Electrical reports each wire connection as it is shown.

This method of influencing from/to connection sequence reporting can fail to give expected results when the orientation of multiple angled tee connection symbols results in either:

- An illogical or impossible connection configuration.
- More than two wires routed to a given wire connection point on a device.

Set the automatic angled wire tee insert mode (instead of tee intersection dots) in the Project Properties ► Styles dialog box.

---

**NOTE** Schematic wire sequencing and Direct-to-Terminal wire sequencing, if present, overrides the Angled Tee connection sequencing.

---

### **Schematic Wire Connection Sequence Method**

This method involves touching the connection sequence for each wire network containing three or more interconnected components. AutoCAD Electrical places an incrementing connection sequence value on each wire connection

point. It is saved as a three-digit Xdata value, starting with “001” on the wire connection attribute. When any of the AutoCAD Electrical From/To reports processes wire networks containing this incrementing sequencing data, the from/to wire connections order accordingly.

---

**NOTE** Schematic wire connection and Direct-to-Terminal sequencing methods on a given wire network take precedence over all other sequencing methods. For example, if a wire network is sequenced with the Edit Wire Sequence tool, the sequencing influence normally provided by angled tee marker symbols used in the wire network is overridden.

---

### **Direct-to-Terminal Wire Connection Sequence Method**

This method defines additional Direct-to-Terminal wire connection sequences. For example, one side of a schematic terminal might be connected to three devices. A specific wire connection sequence (using the Schematic Wire Connection sequence method previously described) can be defined to force the connection reporting. It is limited to reporting the terminal as a common connection point between only two of the three devices. The third device would default to being reported as jumpered to one of the other two devices. Additional secondary Direct-to-Terminal sequences can be defined so that the third device can be sequenced directly to the terminal. You can also directly sequence two terminals together. The result is that the From/To connection reporting shows all three devices tied directly to the terminal.

---

**NOTE** The limit of Direct-to-Terminal sequences that you can define in a single wire network is 50.

---

### **Level/Routing Method**

This method brings the panel layout into play to affect the reporting sequence in the various From/To reports. The panel layout or panel wiring diagram layout representations are assigned level/routing codes consisting of a four-level hierarchy plus a sequence number. As schematic wire networks are processed for the From/To reports, the existence of panel layout representations that are marked with level/routing values is checked. If this information is found for all the devices of the network being processed, the connections of the network are sorted by this hierarchy and sequence information. The result is a set of From/To reported connections that follow the level/routing data carried by the layout.

---

**NOTE** Schematic wire sequencing and Direct-to-Terminal wire sequencing, if present, override the influence of Level/Routing sequencing.

---



## Edit the connection sequence of a wire network

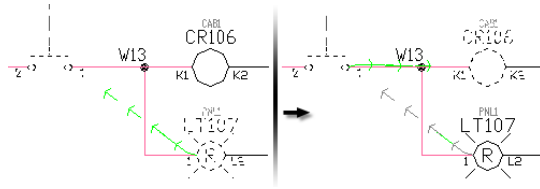

You can explicitly define the wire connection sequence of any wire networks consisting of three or more interconnected devices. You control how AutoCAD Electrical analyzes the circuits (such as the order of the contents in the WFRM2ALL table in the project's scratch database file) and how from/to connection information is output to various reports or annotated on to physical footprint representations (using the [Wire Annotation of Panel Footprint](#) on page 1588 tool).

---

**NOTE** The asterisk (\*) next to a wire in the Wire Connection Sequence portion of the Edit Wire Connection Sequence dialog box indicates that the device wire connection is on another drawing. A "t" indicates that the device is a schematic terminal and is a candidate for Direct-to-Terminal sequencing.

---

This tool predefines the connection sequence of a wire network. The network can be either fully contained on the active drawing or pass across multiple drawings using signal source/destination symbols.

- 1 Click Schematic tab ➤ Edit Wires/Wire Numbers panel ➤

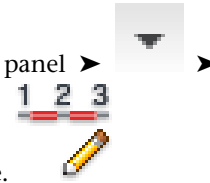

Wire Sequence drop-down ➤ Edit Wire Sequence.

---

**NOTE** You can also access this tool by right-clicking on any wire segment in the wire network.

---

- 2 Select any wire segment on the wire network you want to process.
- 3 On the Edit Wire Connection Sequence dialog box, adjust the connection to connection sequencing in the list by clicking Move Up or Move Down or click Pick Mode to define the sequencing by actual picks at each wire connection point.

---

**NOTE** Pick Mode is unavailable when you are working with a wire network that crosses multiple drawing files. If you are working with wire networks that jump to one or more additional drawings, click Freshen to update the wire connectivity database with any out-of-date files.



---

- 4 (Optional) To connect additional components directly to a given terminal, select the components and the terminal (marked with a “t” in the left-hand column) in the Wire Connection Sequence list and click Add. A copy of the terminal and the actual component move to the Direct-to-Terminal Secondary Sequences list at the bottom of the dialog box. You can then click Move Up or Move Down to change the order of the sequence (if you selected two or more devices plus a terminal) or remove a sequence by selecting the sequence and clicking Reset.
- 5 Click OK-new.  
Writes the sequence information back to the component wire connections (as Xdata on the wire connection attributes and optionally to terminal symbols in the case of Direct-to-Terminal Secondary sequencing).
- 6 (Optional) Right-click a wire on the wire network and select Wire Sequence
  - Show Wire Sequence. Press the spacebar to advance through the sequence.  
You can also view the results of your sequencing by running the Wire From/To report.

### Show a defined wire sequence

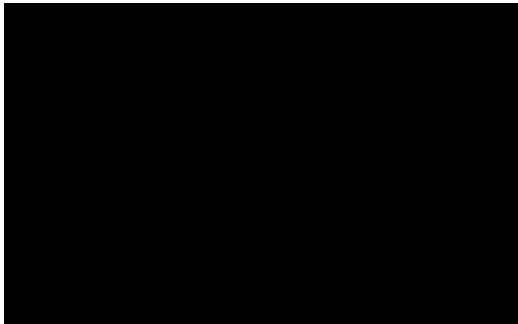
Show the defined wire sequence on the selected wire network. You can also right-click any wire segment in the wire network to access this tool.



- 1 Click Schematic tab ► Edit Wires/Wire Numbers panel ►  ►   
Wire Sequence drop-down ► Show Wire Sequence.

---

**NOTE** You can also access this tool by right-clicking on any wire segment in the wire network.

---

- 2 Press the Space bar to step through the defined wire sequence.

---

**NOTE** If the wire sequence crosses multiple drawings and you try to view the sequence as an animation, a dialog box listing the off-drawing wire connection information displays so that you can indicate to go to the other drawings to continue viewing the sequence.

---

## Insert wire tee markers

Use the tee marker tools to insert dot tee markers or angled tee markers at existing wire tee intersections. If a tee marker is present, the tools change existing markers from dot to angled or from angled to dot. This dot and angled tee insertion happens automatically when you use the Insert Wire tool and the drawing is set up (in the Drawing Properties ► Styles dialog box) for dots or angled tee symbols at intersections.

You cannot insert a tee connection symbol into empty space. A valid line wire ending (not crossing) at a tee intersection somewhere along the length of another line wire is needed. It does not insert a tee connection symbol at a simple 90-degree wire turn. You can right-click on any inserted tee markers for access to editing tools such as Toggle Angled Tee Markers, Delete Component, Scoot, or Insert Wire.

### Insert dot tee markers

Inserts wire connection dots at tee intersections.

Replaces any existing angled wire connection symbol with a dot connection symbol. To insert the dot tee markers automatically as each wire tee intersection is created, set the default Wire Tee connection in the Wiring Style section of the Drawing Properties: Styles dialog box.



- 1 Click Schematic tab ► Insert Wires/Wire Numbers panel ► Insert Dot,



Tee Markers drop-down ► Insert Dot Tee Markers.

- 2 Select at or near the intersection point.

Right-click on the marker and select Delete Component to remove an inserted tee connection symbol and heal the wires.

### Insert angled tee markers

Inserts an angled tee connection symbol at an existing wire intersection.

Replaces any existing dot wire connection symbol with an angled connection symbol. To insert the angled tee markers automatically as each wire tee intersection is created, set the default Wire Tee connection in the Wiring Style section of the Drawing Properties: Styles dialog box.



- 1 Click Schematic tab ➤ Insert Wires/Wire Numbers panel ➤ Insert Dot, Tee Markers drop-down ➤ Insert Angled Tee Markers.



- 2 Select at or near the intersection point.  
If a dot marker is present, it is deleted and replaced by the angled tee symbol.
- 3 After the symbol inserts and reconnects to the wiring, press the spacebar or Enter to switch the inserted tee through four different orientations. Press Esc when the appropriate orientation displays.

---

**NOTE** To change the orientation of the tee symbol after insertion, right-click on the marker and select Toggle Angled Tee Markers (or select the tool from the ribbon or toolbar). To customize the appearance of these symbols, edit the tee symbols stored in the selected schematic symbol library. These tee symbol names are HT0\_###.dwg and VT0\_###.dwg where # = combinations of 1,2,4, and 8. Each symbol carries attribute WDWSEQ with a three-digit value indicating wire connection sequence priority for the three wire connection points of the symbol.

---

Right-click the marker and select Delete Component to remove an inserted tee connection symbol and heal the wires.

### Toggle angled tee markers

Toggles an existing angled tee connection symbol, or windowed symbols, through a total of four possible orientations.

Right-click or press the spacebar to step through the various tee connection orientations. Press ESC when the appropriate orientation displays.

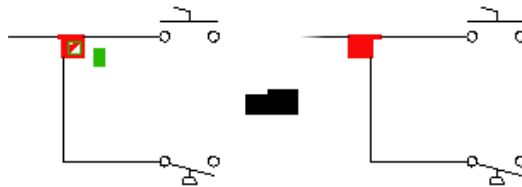

- 1 Click Schematic tab > Edit Wires/Wire Numbers panel >  >



Toggle Angled Tee Markers.

- 2 Select or window the tee connections to change.
- 3 Right-click or press the spacebar to toggle through the various tee connection orientations, and press Esc when the appropriate one displays. Replaces any dot tee symbols with angled tee symbols and then cycles through the four possible orientations for each.

## Edit wire connection sequence

Defines a wire connection sequence to control wire from/to reporting.

-  **Ribbon:** Schematic tab > Edit Wires/Wire Numbers panel >  >

1 2 3

- Wire Sequence drop-down > Edit Wire Sequence. 

1 2 3

-  **Toolbar:** Wires 

-  **Menu:** Wires > Wire Miscellaneous > Edit Wire Sequence

-  **Command entry:** AEEDITWIRESEQUENCE

Predefine the connection sequence of a wire network. The network can be fully contained on the active drawing, or can pass across multiple drawings using signal source/destination symbols.

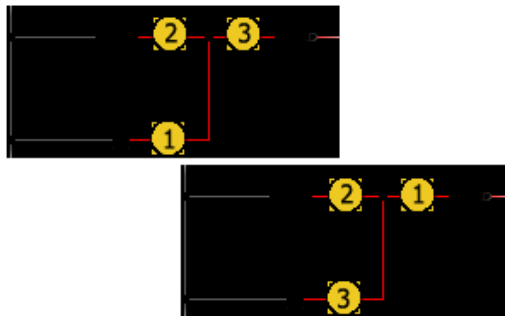

Defining the sequence gives you control over how AutoCAD Electrical analyzes the circuits including:

- The order of the contents in the WFRM2ALL table in the project database file
- How from/to connection information is output to various reports
- Annotation on physical footprint representations (using the [Wire Annotation of Panel Footprint](#) on page 1588 tool).

---

**NOTE** You can also access it by right-clicking on any segment of a wire network and selecting Wire Sequence ► Edit Wire Sequence.

---

Provides these features to define the sequence order:

- Sort the components by physical location.
- Move the components up or down in the listing.
- Pick mode, in the active drawing only, where you pick the wire connection points to define the connection sequence.

Once you specify the sequencing, you can use the Show Wire Sequences tool to view the sequence or use the Wire From/To reporting tool to see how the sequencing is reported.

---

**NOTE** Your dialog box differs depending on whether you selected to modify the sequence of a wire network that is connected to a terminal. When a terminal is part of the selected wire network, you have an option to define secondary Direct-to-Terminal wire connection sequences.

---

#### Wire Connection Sequence

Lists the wires and terminals found in the circuit. The \* indicates that the wire is on another drawing and the "t" indicates that the entry is a terminal and a candidate for a direct-to-terminal secondary sequence definition.

---

**NOTE** Components connected on the far side of a terminal (on a side opposite of the picked wire network) are not displayed in the list, even if the terminal is one that does not change the wire number through it.

---

<b>Pick Mode</b>	<p>Defines the sequence by actual picks at or very near each wire connection point. Pick near each wire connection in the order of how you want the wiring sequence to proceed from component to component.</p> <hr/> <p><b>NOTE</b> Pick Mode is unavailable when you are working with a wire network that crosses multiple drawing files.</p> <hr/>
<b>Sort Location</b>	<p>Automatically sorts the wire connection display by the installation and location values. If previously sorted, the sort is reversed.</p>
<b>Move Up</b>	<p>Moves the selected wire connection up one space in the wire order list.</p>
<b>Move Down</b>	<p>Moves the selected wire connection down one space in the wire order list.</p>
<b>Direct-to-Terminal Secondary Sequences</b>	<p>Lists additional sequences where a component connection (or terminal connection) is to be reported as being directly wired to a selected terminal.</p>
<b>Add</b>	<p>Moves the selected components to the Direct-to-Terminal Secondary Sequences list along with a copy of the selected terminal. Select the components and terminal to sequence together for this button to be available.</p> <p>If you select multiple components to daisy-chain to the terminal (by holding CTRL key down), the first selected component displays ties directly to the terminal.</p>
<b>Reset</b>	<p>(available only when an entry in the sequence is highlighted) Removes the selected sequencing from the Direct-to-Terminal Secondary Sequences list. The component is moved back to the Wire Connection Sequence list.</p>
<b>Connection</b>	<p>Indicates whether the component is undefined (-), reported on the internal side of the terminal (I) or reported on the external side of the terminal (E). If</p>



selected, an I or E displays in the PD1 or PD2 column (Point Description) of the Wire From/To report.

**Freshen**

Updates the wire connectivity database (the WFRM2ALL table) with wire connection information from any out-of-date files.

---

**NOTE** If all drawings are up-to-date, this button is disabled. If not, the button is enabled and the count of out-of-date drawings displays next to the button.

---

**Remove All**

Removes the wire connection sequence override information from a wire network. It consists of Xdata assignments on component wire connection attributes and optional Xdata assignments on terminal symbols if any Direct-to-Terminal sequences are defined.

---

**NOTE** If the network includes one or more IEC-style wire "Tee" connection symbols, the sequencing defined by their placement and orientation is not affected. The result is that values may remain in the Current column.

---

**OK-new**

Applies the wire connection sequence information in the form of Xdata to the wire connection points and terminals of the selected wire network. This sequence data is then maintained inside the drawing file. It is later extracted into the project scratch database file to control the format of wire connections listed in the WFRM2ALL table.



## Insert terminals and connectors

Terminal symbols on the schematic are a representation of wire connection points. The terminal symbol representation on the schematic can have associations with the physical terminal block on the panel drawing. To insert a terminal, select the Insert Component command to display the icon menu, and then select Terminals/Connectors.

There are four types of terminal behavior that you can select from and five main terminal styles (square, round, hexagon, diamond, and triangle). Each type of terminal behavior is controlled by the terminal block name.



Non-intelligent terminals. They do not show up in reports.  
\*//



Terminals that take on a terminal number that matches the wire number passing through or connected to the terminal.



Terminals that carry a user-defined terminal number.



Terminals that force a new wire number to generate as a wire passes through the terminal.

## Insert terminals

You can select from five main terminal styles (square, round, hexagon, diamond, and triangle). Each type of terminal behavior is controlled by the terminal block name.

- 1 Click Schematic tab ► Insert Components panel ► Insert Components



drop-down ► Icon Menu.

- 2 Click the Terminals/Connectors button.
- 3 Select a terminal symbol to insert.
- 4 Specify the insertion point.
- 5 On the Insert/Edit Terminal Symbol dialog box, annotate the terminal symbol including (but not limited to) the terminal number, tag strip value, and catalog information.

## Insert/edit terminal symbol

Annotates the terminal by tracking which terminal numbers and terminal strip ID names were used so far.

### Insert Component

 **Ribbon:** Schematic tab ► Insert Components panel ► Insert Components



drop-down ► Icon Menu.



 **Toolbar:** Main Electrical

 **Menu:** Components ► Insert Component

 **Command entry:** AECOMPONENT

Select Terminals and Connectors, select the terminal to insert, and specify the insertion point on the drawing.

## Edit Component

 **Ribbon:** Schematic tab ► Edit Components panel ► Edit Components

drop-down ► Edit.



 **Toolbar:** Main Electrical

 **Menu:** Components ► Edit Component

 **Command entry:** AEEDITCOMPONENT

Select the terminal to edit.

## Terminal

These controls determine the overall tagging of the terminal block in the project. The Installation, Location, and Tag Strip values define which strip the terminal belongs to. The symbol block file name displays at the top of the Terminal group.

---

**NOTE** Assign short installation or location codes to components like "PNL" and "FIELD" to take full advantage later of the AutoCAD Electrical ability to create installation or location-specific Bill of Materials and component lists.

---

### Installation

Changes the installation codes. Click Browse to search the active drawing, entire project, and an external list (default.inst) for installation codes. Pick from the list to update the component automatically with the installation code.

### Location

Changes the location codes. Click Browse to search the active drawing, entire project, and an external list (default.loc) for location codes. Pick from the list to update the component automatically with the location code.

### Tag Strip

Specifies the Tag ID given to the terminal strip. If there is an existing name, it appears in the edit box; if not, you can enter a specific ID name. Click the < and > buttons to increment or decrement the last digit/character in the Tag Strip value.

**Number**

Specifies the terminal number. If there is not PIN-LIST information, the < and > buttons increment or decrement the terminal number. You can also click Pick to select a text object or an attribute on the active drawing to use for the terminal number. When inserting a new terminal, the highest terminal number in the strip is identified and the default terminal number for the new terminal increments by 1.

---

**NOTE** This is unavailable when the terminal symbol does not have a TERM01 attribute or when the terminal number is the same as the wire number.

---

**Modify Properties/Associations**

These controls support associations between schematic terminal symbols and their panel terminal footprint or between multiple schematic terminal symbols.

There are certain conditions that you cannot associate terminals using the Modify Properties/Associations options:

- The drawing is not part of the active project.
- You are using the Insert Terminal (Panel List) tool. However, once you exit the Insert Terminal (Panel List) tool and the terminal is inserted onto the drawing, you can modify the associations using these tools.
- The terminals were inserted by the Terminal Strip Editor tool.
- The terminals are one-line terminal symbols.

**Add/Modify**

Displays the Add/Modify Associations dialog box where you can select terminal strips and their respective blocks to make an association to the terminal symbol being inserted or edited.

---

**NOTE** It is disabled if the active drawing is not part of the active project.

---

**Pick**

Selects another terminal symbol on the active drawing to associate to. You can select only one terminal symbol to make the association.

---

**NOTE** While in selection mode, you can use Pan or Zoom to find the terminal symbol to select.

---

**Break Out**

Removes the terminal being edited out of the defined association. The properties from the original association and the levels of the terminal are maintained.

**Block Properties**

Displays the Block Properties dialog box where you can define and maintain terminal block properties.

**NOTE** It is disabled if the active drawing is not part of the active project.

---

### Properties/Associations

The list box displays the current status of the association of the edited terminal. It lists all associated terminal symbols from the schematic and terminal panel footprints. If the terminal symbol is being inserted for the first time, the list box only displays the reference for itself. The number of levels defined in the block properties displays at the top of the Properties/Associations group. The terminal being edited is highlighted in the list box.

You can double-click in the list to modify the terminal association in the Add/Modify Associations dialog box.

**Label**

Lists the level description defined in the terminal block properties. This data is entered into the LnnLABEL attribute if present; otherwise, it is placed into xdata.

**Number**

Lists the terminal numbers defined in the association. Only one terminal number is allowed per level and each level displays its respective terminal number or text. Panel terminal symbols do not display terminal numbers.

**PinL**

Lists the pin numbers defined on the left side of the terminal block. This data is entered into the LnnPINL attribute if present; otherwise, it is placed into xdata.

**PinR** Lists the pin numbers defined on the right side of the terminal block. This data is entered into the LnnPINR attribute if present; otherwise, it is placed into xdata.

**Reference** Lists the reference location of the terminal symbol in the project. The syntax is 'Sheet,Reference' based on the drawing configuration.

---

**NOTE** This area is disabled if the terminal is a one-line symbol. Multi-level or panel relationships are not supported for one-line terminals.

---

### **Project List**

These controls allow for quick selection of terminal strips and terminal numbers used throughout the active project.

**Project List** Shows all the previously defined terminal strips in the active project. When inserting a new terminal, this list is populated with the Installation, Location and TAGSTRIP values of the previously inserted terminal.

**Numbers Used** Lists all terminal numbers found, either drawing-wide or project-wide, whose Tag Strip value matches the highlighted Tag Strip value.

### **Catalog Data**

You can do a drawing-wide or project-wide listing of similar terminals with their catalog assignments. During your editing session, the last MFG / CAT / ASSYCODE assignment for each terminal type you insert into your wiring diagram is remembered. When you insert another terminal of that type, the catalog assignment of the previous terminal is set as the default (assuming a previous one was made during the current editing session).

**Manufacturer** Lists the manufacturer name for the terminal. Enter a value or select one from the Catalog lookup.

**Catalog** Lists the catalog number for the terminal. Enter a value or select one from the Catalog lookup.



<b>Assembly</b>	Lists the assembly code for the terminal. The Assembly code is used to link multiple part numbers together.
<b>Item</b>	Specifies a unique identifier assigned to each terminal. The value can be manually typed in the edit box.
<b>Catalog Lookup</b>	Opens the catalog database of the terminal from which you can select the Manufacturer and Catalog values. Search the database for a specific catalog item to assign to the selected terminal.
<b>Drawing</b>	Lists the part numbers used for similar terminals in the active drawing.
<b>Project</b>	<p>Lists the part numbers used for similar terminals in the project. You can search in the active project, another project, or in an external file.</p> <ul style="list-style-type: none"> <li>■ <b>Active project:</b> All the drawings in the active project are scanned and the results are listed in a dialog box. Select from the list to assign your new terminal with a catalog number that is consistent with other similar terminals in the project.</li> <li>■ <b>Other project:</b> Scans each listed drawing in a previous project for the target terminal type and returns the catalog information in a sub-dialog box. Make your catalog assignment by picking from the list.</li> <li>■ <b>External file:</b> You can pull catalog assignments from a generic ASCII file created by a word processor or output from a spreadsheet or database program. A dialog box displays the contents of the selected text file. Find and highlight the desired entry. AutoCAD Electrical reads the line of text from the file and breaks it into its component parts. These are displayed in the left-hand list. For each relevant item, highlight it and then pick the appropriate category button in the center column. The highlighted item is transferred to the corresponding category (and then to the Insert/Edit dialog box once OK is clicked).</li> </ul>
<b>Multiple Catalog</b>	Inserts or edits extra catalog part numbers on to the selected terminal. You can add up to ten part numbers to any terminal. These multiple BOM part numbers appear as subassembly part numbers to the main catalog part number in the various BOM and terminal reports.

**Catalog Check**

Extracts the details from the catalog database to display what the selected item looks like in a Bill of Material template.

**Descriptions**

Specifies the optional description attribute text to assign to the terminal block (up to three lines of text can be specified). Click Browse to search for all terminal descriptions in the project or active drawing. Select the description you want to copy to the edited terminal block by selecting it in the list and clicking OK.

---

**NOTE** These edit boxes are disabled if the terminal does not carry the attributes (such as ratings).

---

**Defaults**

Opens an ASCII text file (wd\_desc.wdd or <project>.wdd) from which you can select standard descriptions.

**Pick**

Picks a description from a component on the current drawing.

**Ratings**

You can enter up to 12 ratings attributes on a component. The View/Edit Rating Values dialog box lets you enter values for each ratings attribute. Select the Defaults button next to the edit box to display a list of default values.

---

**NOTE** If this button is unavailable, the component you are editing does not carry any rating attributes.

---

**Show/Edit Miscellaneous**

View or edit any attributes that are not predefined AutoCAD Electrical attributes.

**Add/modify associations**

This tool searches project terminal strips for existing terminal blocks, allowing you to associate a terminal symbol to an existing association or terminal.

### Insert Component

 **Ribbon:** Schematic tab ► Insert Components panel ► Insert Components

drop-down ► Icon Menu.

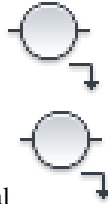

 **Toolbar:** Main Electrical

 **Menu:** Components ► Insert Component

 **Command entry:** AECOMPONENT

Select Terminals and Connectors from the dialog box and specify the insertion point on the drawing. In the Insert/Edit Terminal Symbol dialog box, Modify Properties/Associations section, click Add/Modify.

### Edit Component

 **Ribbon:** Schematic tab ► Edit Components panel ► Edit Components

drop-down ► Edit.

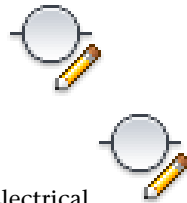

 **Toolbar:** Main Electrical

 **Menu:** Components ► Edit Component

 **Command entry:** AEEDITCOMPONENT

Select the terminal to edit. In the Insert/Edit Terminal Symbol dialog box, Modify Properties/Associations section, click Add/Modify.

---

**NOTE** This option is also available from the Panel Layout - Insert/Edit Terminal Footprint dialog box.

---

Modifications to the terminal symbol associations affect every terminal symbol in the association so all drawings must be available for editing. You cannot edit other terminal associations from this dialog box; only the associations of the selected terminal symbol can be edited.

## Active Association

Use this section to modify the terminal number. The Installation, Location, and Tag Strip values are not editable.

<b>Installation</b>	Displays the Installation value defined for the edited terminal symbol.
<b>Location</b>	Displays the Location value defined for the edited terminal symbol.
<b>Tag Strip</b>	Displays the tag strip value defined for the edited terminal symbol.
<b>Number</b>	(Unavailable for panel terminals) Specifies the terminal number. The displayed value is defined in the TERM01 attribute on the terminal symbol. <hr/> <b>NOTE</b> If this value is the wire number defined in the WIRENO attribute on the terminal symbol, you cannot change the value.

## Active Associations grid

Displays all terminal symbols that are currently associated to the terminal being edited. The terminal symbol that is being edited is highlighted in light blue. Right-click on a terminal symbol to move it up or down one level or select a terminal symbol and drag it to a new level location. Label and Pin information do not move with the terminal symbol number and reference since it is part of the terminal block property definition.

---

**NOTE** The panel symbol association is always at the bottom and cannot be selected for movement.

---

- **Level numbering:** Displays a level number for each level that is defined in the terminal properties. The level numbering for the panel symbol is “#.”
- **Label:** Lists the level description defined in the terminal block properties.
- **Number:** Lists the terminal numbers defined in the association. Only one terminal number is allowed per level and each level displays its respective terminal number or text. Panel ter-

terminal symbols do not display terminal numbers. Terminal levels with an assignment and a terminal that has not been assigned a terminal number display a “???” in this column.

- **PinL:** Lists the pin numbers defined on the left side of the terminal block. This data is entered into the LnnPINL attribute if present; otherwise, it is placed into Xdata.
- **PinR:** Lists the pin numbers defined on the right side of the terminal block. This data is entered into the LnnPINR attribute if present; otherwise, it is placed into Xdata.  
Pin numbering is related to the terminal level and not the terminal tag number instance.
- **Reference:** Lists the reference location for the terminal symbol in the project. The syntax is “Sheet,Reference” based on the drawing configuration.

## Select Association

### Terminal Strips

Displays all terminal strips inside of the active project. The tree contains three nodes to aid in finding a specific terminal block in the project. The nodes are: active project name, Tag Strip value (Installation and Location included) and terminal blocks.

- **Active Project node:** Displays the name of the active project.



- **Tag Strip Value node:** Displays the entire Installation, Location, and Tag Strip values for all terminal strips in the active project. The terminal block quantity displays at the end of the node string in parenthesis.



- **Terminal Block node:** Displays the terminal numbers defined on the block (separated by commas). The number of

levels defined in the block properties displays at the end of the node string in parenthesis.

For example, 1,21,GND (3).

If a level is not represented on the schematic, an empty space represents it: 1, , GND (3). If a terminal has been assigned to the level, but the terminal does not have a number assignment, a '???' represents it: 1,???,GND (3).

#### Select Association grid

Displays all levels of the terminal selected in the tree. Select the level to place the edited terminal in and right-click to run the associate command (or click Associate).

#### Associate

Adds the edited terminal symbol to the terminal association. A terminal number is then inserted into the Number column and the Reference column is updated with the terminal reference defined in the drawing properties.

---

**NOTE** The grid row must be selected before you can perform the association.

---

This option is unavailable until you select a level in the grid control when editing a schematic terminal or until you select a terminal from the tree control when editing a panel footprint. A grid selection is not required for panel footprints since the footprint is associated to the entire terminal, not an individual level.

## Terminal block properties

Use this dialog box to control the number of levels assigned to a multiple level terminal block. You can control the level description, number of wires per connection, pins right, pins left and internal jumpers. The terminal block properties are maintained on every terminal symbol in its association.

### Insert Component

 **Ribbon:** Schematic tab ► Insert Components panel ► Insert Components

drop-down ► Icon Menu.

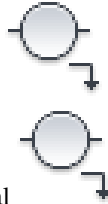

 **Toolbar:** Main Electrical

 **Menu:** Components ► Insert Component

 **Command entry:** AECOMPONENT

Select Terminals and Connectors from the dialog box and specify the insertion point on the drawing. In the Insert/Edit Terminal Symbol dialog box, click Block Properties.

### Edit Component

 **Ribbon:** Schematic tab ► Edit Components panel ► Edit Components

drop-down ► Edit.

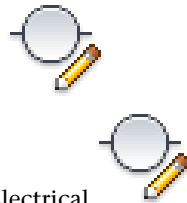

 **Toolbar:** Main Electrical

 **Menu:** Components ► Edit Component

 **Command entry:** AEEDITCOMPONENT

Select the terminal to edit. In the Insert/Edit Terminal Symbol dialog box, click Block Properties.



---

**NOTE** You can also access this dialog box by clicking Edit Terminal Block Properties on the Terminal Strip Editor dialog box.

---

The default level for any terminal symbol that is placed into the project that is not associated to another is 0.

<b>Manufacturer</b>	Displays the Manufacturer value that is currently assigned to the terminal being edited.
<b>Catalog Number</b>	Displays the Catalog Number value that is currently assigned to the terminal being edited.

<b>Assembly Code</b>	Displays the Assembly Code value that is currently assigned to the terminal being edited.
<b>Levels</b>	Specifies the number of levels for the terminal. The grid expands for editing based on the number of levels specified. You can then define the level description, wires per connection and pins.
<b>Terminal Block Property Definition grid</b>	<p>Displays the terminal levels. You can edit and maintain properties of the terminal block here.</p> <ul style="list-style-type: none"> <li>■ <b>Level Description:</b> Specifies the description for the levels of the terminal block. Text you enter here displays in the Insert/Edit Terminal Symbol and Terminal Block Properties dialog boxes. This value is a terminal property that is maintained on every symbol in its association.</li> <li>■ <b>Wires per Connection:</b> Specifies the number of wires allowed per connection for the terminal connection point.</li> </ul> <hr/> <p><b>NOTE</b> These properties do not limit the number of connections allowed on the schematic.</p> <hr/> <ul style="list-style-type: none"> <li>■ <b>Pin Left/Pin Right:</b> Specifies labels for pin numbers associated to the terminal destinations. These fill in the LnnPINL and LnnPINR attributes on the terminal block when its level is selected. This value is a terminal property that is maintained on every symbol in its association.</li> <li>■ <b>Internal Jumper:</b> Graphically indicates internal jumpers assigned between levels.</li> </ul>
	Internally jumper the levels currently selected in the grid.
	Delete the internal jumper currently assigned to the levels selected in the grid
<b>Clear</b>	<p>Clears all terminal block properties.</p> <hr/> <p><b>NOTE</b> Properties for a level cannot be cleared if there is a schematic terminal representing that level (other than the terminal being edited), or there is an external jumper on that level.</p> <hr/>



### Terminal block property attributes

The values in the grid are stored as follows. The “nn” represents the level number and is always stored as two digits (that is, 01, 02, and so on):

Data	Attribute
Level Description (60 characters maximum)	LnnLABEL
Wires Per Connection (three characters maximum)	LnnWIREPERC
Pin Left (12 characters maximum)	LnnPINL
Pin Right (12 characters maximum)	LnnPINR
Internal Jumper (255 characters maximum)	LnnINJUMP

---

**NOTE** If these attributes are not present, the data is placed into Xdata with the same name, only with a “VIA\_WD\_” prefix.

---

## Multi-Level Terminals

### Overview of terminal relationships

AutoCAD Electrical supports two types of relationships for terminals: schematic-to-schematic and schematic-to-panel.

---

**NOTE** Since one-line terminal symbols likely represent multiple, independent terminals, they cannot be associated to other schematic or panel terminals. A one-line terminal must be updated manually. A one-line terminal symbol is defined by a [WDTYPE attribute](#) on page 325 value of “1-”.

---

#### Schematic-to-Schematic

The schematic-to-schematic relationship defines separate schematic terminal symbols as one multi-level (also referred to as multi-tier or multi-stack) terminal block. On the schematic drawing, each schematic terminal symbol represents one level of the multi-level terminal block.

---

**NOTE** Multiple terminal symbols for one level are not currently supported.

---

The number of levels for the block is defined as a block property. Each level carries certain characteristics, such as a label, wires per connection, left pin, and right pin. Each schematic terminal symbol carries all the block properties for each level so that removing one terminal symbol does not remove the block properties. If a block property is modified, all the terminal symbols update.

An ID value held on the LINKTERM attribute or Xdata, associates the terminal symbols. When a terminal symbol is inserted, by default it is seen as a standalone terminal (it has no associations) and receives a new LINKTERM value. When the terminal is associated to another, the LINKTERM value updates so that each terminal carries the same LINKTERM value. Changing or removing the LINKTERM value breaks any associations that terminal has.

To associate schematic terminals, first add block properties. The number of terminals you can associate is limited to the number of levels defined in the block properties. Once block properties are established you can associate schematic terminals to build a multi-level terminal block by:

- Click Schematic tab > Edit Components panel >  > Associate



Terminals.

You select a master terminal and then select each terminal symbol to associate to the master.

- Clicking Pick on the Insert/Edit Terminal Symbol dialog box. It adds the edited symbol into an association with the picked terminal.
- Clicking Add/Modify on the Insert/Edit Terminal Symbol dialog box. It adds the edited symbol into an association with any schematic terminal in the project.

Prebuilt circuits can contain associated terminals. These relationships are maintained when the circuit is inserted. Copying a circuit also maintains these relationships within the copied circuit.



When the Bill of Materials report is run, these separate terminal symbols that make up one multi-level terminal, are counted as one in the quantity.

### Schematic-to-Panel

The schematic-to-panel relationship is used mainly for updating. If the schematic or panel is modified, the other updates to reflect the changes. This

relationship is like component relationships, which are based on the TAG value. The TAGSTRIP, Installation, and Location values must match for the terminals to associate together. The association number on the LINKTERM is also taken into account when creating a relationship between the schematic terminal and its panel representation. Block properties are not required to associate a schematic to panel terminal. Once they are associated, modifications on one results in modifications on the other.

You can associate a schematic and panel terminal automatically by:

- Click Panel tab ► Terminal Footprints panel ►  ► Insert  
Terminals drop-down ► Insert Terminal (Schematic List) 
- Click Schematic tab ► Insert Components panel ► Insert Components  
drop-down ► Terminal (Panel List) 

For multi-level terminals, the Insert Terminal (Schematic List) tool shows only one terminal for insertion regardless of how many schematic terminal symbols/levels there are for that multi-level block. The Insert Terminal (Panel List) tool shows one terminal for each level for insertion.

---

**NOTE** Panel terminals inserted by the Terminal Strip Editor are automatically associated to the schematic representation.



---

You can click the [Associate terminals](#) on page 1055 tool to select terminals to associate or click Add/Modify on the Panel Layout - Terminal Insert/Edit dialog box to add the panel terminal to an association with a schematic terminal on any drawing in the project.

## Associate terminals

Use the Associate Terminals tool to associate two or more terminal symbols together. Associating schematic terminals combines the terminals into a single terminal block property definition. The number of schematic terminals that can be combined is limited to the number of levels defined for the block properties.

Associating a panel terminal provides a way to define a particular panel footprint to represent a schematic block property definition.

- 1 Click Schematic tab ► Edit Components panel ►  ► Associate Terminals. 

- 2 Select a terminal symbol to use as the master. It is used as the basis for any terminal property definition.

---

**NOTE** Your terminal symbol must have block properties defined. To define block properties, right-click on the symbol and select Edit Component. In the Insert/Edit Terminal Symbol dialog box, click Block Properties.

---

- 3 Select additional terminal symbols to add to the association of the master terminal.
- 4 Press Enter to associate the terminals.  
The catalog data, block properties, Tagstrip value, Installation code and Location code are copied from the master terminal and added to the terminals in the association.

---

**NOTE** If the number of selected terminals exceeds the total number of levels defined in the block properties, an alert displays and the extra terminals are not added to the association.

---

### Tips and Hints

- This tool works on terminal symbols on the same drawing only.
- If the master terminal is already part of another association, the existing association is maintained and the newly selected terminal symbols join the association.
- If the selected terminals are part of their own association, they are removed from the association and added to the new association with the selected master terminal.
- Terminals placed onto the drawing using the Terminal Strip Editor cannot be added to an association using this tool.

## Show terminal associations

Use the Show Terminal Associations tool to display the current associations for the selected terminals. AutoCAD Electrical draws temporary lines between the associated terminals. These graphics disappear the next time you do a Regen.

- 1 Click Schematic tab > Edit Components panel >  > Show



Terminal Associations.

- 2 Select the terminals you want to view the associations of.  
Red dashed lines are drawn between the terminals that are associated to the selected terminal. A list of the associated terminals also displays at the command prompt.

## Break apart terminal associations

Use the Break Apart Terminal Associations tool to break a terminal symbol out of an existing association. Schematic terminals are removed from any multi-tier relationship and any schematic-panel relationships. Panel terminals are removed from any schematic-panel relationships.

---

**NOTE** The properties of the existing terminal association are maintained on each symbol.

---

- 1 Click Schematic tab > Edit Components panel >  > Break Apart



Terminal Associations.

- 2 Select the terminal to remove from the association. Repeat for each terminal you want to break out of its associations.
- 3 Press Enter.

## Copy terminal block properties

Use the Copy Terminal Block Properties tool to copy terminal properties from one terminal symbol to another. If the application of the terminal properties

reduces the number of levels and the number of schematic terminal symbols in the association exceeds the total allowed, an alert displays and the properties are not copied.

- 1 Click Schematic tab ► Edit Components panel ►  ► Copy



Terminal Block Properties.

- 2 Select the master terminal to copy properties from.
- 3 Select the terminals to apply the properties to.
- 4 Press Enter.

## Terminal Properties Lookup

### Overview of terminal properties database

The terminal properties database file (\_TERMPROPS table in the default\_cat.mdb) can be viewed, edited, and expanded using the Terminal Properties Database Editor tool. The terminal properties table holds the terminal properties based on the manufacturer, catalog, and assembly code entries. When a catalog assignment is made to a terminal, it looks to the terminal properties table for a matching entry and pulls out and assigns the properties when a match is found. The following wild cards are supported in the catalog field:

- \* = matches any characters
- ? = matches a single character
- # = matches a single numeric digit
- @ = matches a single alphabetic character

#### Structure of the terminal properties database table

RECNUM

(Microsoft Access internal use)

<b>MANUFACTURER</b>	Manufacturer code (value must be consistent with the catalog lookup files; 24 characters maximum)
<b>CATALOG</b>	Catalog number (use wild cards as much as possible; 60 characters maximum)
<b>ASSEMBLYCODE</b>	AutoCAD Electrical internal assembly code (must be consistent with the catalog lookup files; 60 characters maximum)
<b>LEVELS</b>	Number of levels for the terminal
<b>LEVELDESCRIPTION</b>	Levels description/level definition (255 characters maximum)
<b>TPINL</b>	Pin label definition for the left side of the terminal (255 characters maximum)
<b>TPINR</b>	Pin label definition for the right side of the terminal (255 characters maximum)
<b>WIRESPERCONNECTION</b>	Definition of the wiring constraints (255 characters maximum)
<b>INTERNALJUMPER</b>	<p>Levels within a multi-tier terminal that are jumpered together. A comma (,) is used as a delimiter between each level within a jumper definition. A semicolon (;) is used as a delimiter between jumper definitions within a terminal.</p> <p>For example, if all levels of a four-level terminal are jumpered together, the value is "1,2,3,4". If levels 1 and 2 are jumpered together, and 3 and 4 are jumpered together, the value is "1,2;3,4".</p>



---

**NOTE** When dealing with a multi-tier terminal, a comma (,) is used as a delimiter for the LevelDescription, WiresPerConnection, TPINR, and TPINL fields. For example, the LevelDescription may be "UPPER,LOWER" and the WiresPerConnection may be "2,2."

---

## Edit terminal properties database

Use the Terminal Properties Database Editor tool to edit the terminal properties database, located in the catalog database.

- 1 Click Schematic tab ➤ Other Tools panel ➤  ➤ Database Editors   
drop-down ➤ Terminal Properties Database Editor.
- 2 In the Select Terminal Properties Table dialog box, select the table to edit and click Edit.

---





**NOTE** You can also create a table by entering the manufacturer name in the edit box and clicking Create.

---

- 3 In the Edit dialog box:
  - To edit a record, click Sort, Filter, or Find to search for the record to edit. Select the record from the list and click Edit.
  - To create a record, click Add New, or select an existing record and click Add Copy to create a record based on an existing one.
  - To delete an existing record, select the record in the list and click Delete.
- 4 To edit or create a record, in the Edit Record dialog box, specify the values to assign to the record and click OK.
- 5 In the Edit dialog box, click Save/Exit.

## Select terminal properties table

Use this tool to select the relevant \_TERMPROPS table to edit or create a new one.

-  **Ribbon:** Schematic tab ➤ Other Tools panel ➤  ➤ Database   
Editors drop-down ➤ Terminal Properties Database Editor.
-  **Menu:** Components ➤ Terminals ➤ Terminal Properties Database Editor





### **Command entry: AETERMDBEDITOR**

<b>Select or Type Manufacturer</b>	Lists all of the TERMPROPS tables that are in the catalog database. The “(Default)” manufacturer is used to edit the generic _TERMPROPS table. Select the table to edit or enter a name for a new one.
<b>Table</b>	Displays the proper table name in the catalog database. This text changes depending on which manufacturer is selected. For example, if you select SQD, then _TERMPROPS_SQD displays.
<b>Create</b>	(Available only when you enter the name of a manufacturer.) Creates a table in the catalog database with the specified name and adds the table to the list of manufacturers. Once a table is created, the Edit (Table: _TERMPROPS_manufacturer) dialog box displays so you can edit the new table. <hr/> <b>NOTE</b> The following characters are not allowed in the table name: ~ @ # \$ % ^ & * - + = \ { } “ ’ ; : ? / < > , ! [ ]  . These characters are replaced with an underscore ( _ ) if entered in the edit box. <hr/>
<b>Edit</b>	(available only after a manufacturer is selected from the list) Opens the Edit (Table: _TERMPROPS_manufacturer) dialog box so you can edit the selected TERMPROPS table.

## **Edit**

AutoCAD Electrical consults a terminal properties database table when a catalog assignment is made to a terminal. Use it to edit the terminal properties database.

 **Ribbon:** Schematic tab ► Other Tools panel ►  ► Database

Editors drop-down ► Terminal Properties Database Editor. 

 **Menu:** Components ► Terminals ► Terminal Properties Database Editor

 **Command entry: AETERMDBEDITOR**

Specify the table to create and click Create or select the table to edit and click Edit.

This lookup database table is a table within the catalog lookup Access .mdb file. The default file name is default\_cat.mdb, table \_TERMPROPS, and comes populated with a sample of vendor data. You can expand this table as needed. Use your own copy of Microsoft Access or use this dialog box to add new entries, add entries based on existing entries, edit, and delete entries from the table.

<b>Sort</b>	Sorts the list of database records using either an alphanumeric sort or number values. You can specify four sorts to perform on the list.
<b>Find</b>	Find the next instance of the text you enter. Select to look in the entire table or a specific field. Select to match the entire field, part of the field, or just the beginning of the field with the entered text. Choose to make it case sensitive by clicking Match case.
<b>Replace</b>	Indicates to replace the find value with the new text string that you specify.
<b>Filter</b>	Filters the listing based on certain values in the table. Picking the blank entry in the list removes the filter for that field. After you define the values to filter, apply the filter in the database editing window.
<b>Edit</b>	Displays the Edit Record dialog box for modifying the existing record in the database.
<b>Add New</b>	Displays the Edit New Record dialog box for entering a new record into the database.
<b>Add Copy</b>	Displays the Edit Copied Record dialog box for modifying and copying the record to make a new record. You cannot have two duplicate copies in the database.
<b>Delete</b>	Removes the selected record from the database.

## **Edit record**

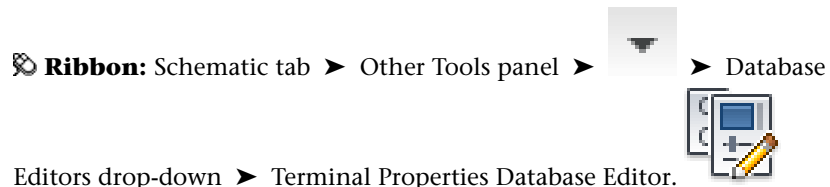

**Menu:** Components > Terminals > Terminal Properties Database Editor

**Command entry:** AETERMDBEDITOR

Specify the table to create and click Create or select the table to edit and click Edit. In the Edit dialog box, click Add New, Add Copy, or Edit.

<b>RECNUM</b>	(Microsoft Access internal use)
<b>MANUFACTURER</b>	Manufacturer code (value must be consistent with the catalog lookup files; 24 characters maximum)
<b>CATALOG</b>	Catalog number (use wild cards as much as possible; 60 characters maximum).
<b>ASSEMBLYCODE</b>	AutoCAD Electrical internal assembly code (must be consistent with the catalog lookup files; 60 characters maximum)
<b>LEVELS</b>	Number of levels for the terminal
<b>LEVELDESCRIPTION</b>	Levels description/level definition (255 characters maximum)
<b>TPINL</b>	Pin label definition for the left side of the terminal (255 characters maximum)
<b>TPINR</b>	Pin label definition for the right side of the terminal (255 characters maximum)
<b>WIRESPERCONNECTION</b>	Definition of the wiring constraints (255 characters maximum)
<b>INTERNALJUMPER</b>	Definition of levels jumpered together within a multi-tier terminal. (255 characters maximum)
	A comma (,) is used as a delimiter between each level within a jumper definition. A semicolon (;) is

used as a delimiter between jumper definitions within a terminal.

For example, if all levels of a four level terminal are jumpered together, the value is "1,2,3,4". If levels 1 and 2 are jumpered together, and 3 and 4 are jumpered together, the value is "1,2;3,4".

When dealing with a multi-tier terminal, a comma (,) is used as a delimiter for the LevelDescription, TPINL, TPINR, and WiresPerConnection fields. For example, the LevelDescription may be "UPPER, LOWER" and the WiresPerConnection may be "2,2."

## Terminal Strip Editor

### Use the terminal strip editor

Use terminal blocks to connect devices that require quick disconnect or disassembly during product shipment, while at other times they can be used to distribute power to other devices. The Terminal Strip Editor defines the locations for these connected devices during the system design process. Terminal strip editing is primarily used towards the end of the control system design cycle to expedite the labeling, numbering, and rearranging of terminals on a terminal strip.

A document that is created to facilitate the construction of a terminal strip and all of its wiring is a terminal strip layout drawing. These drawings display the general arrangement of all the terminal blocks that belong to a specific terminal strip. You can also display the wiring and device connection information next to the terminal block symbol using the Terminal Strip Editor. You can rely on the terminal strip layout drawing for all information regarding the terminal strip without having to reference the schematic drawings.

The Installation (INST), Location (LOC) and Tag Strip (TAG\_STRIP) values are used to determine the uniqueness of a terminal strip no matter which standard is used in the active project (such as IEC or JIC).

After changes are made with the Terminal Strip Editor, the changes are written back to the schematic drawing for future updates, and a graphical or tabular drawing of a terminal strip layout is created. Your drawing must be part of the active project to perform updates.

---

**NOTE** If you change an existing graphical terminal strip, the Terminal Strip Editor requires that the terminal strip is refreshed or placed on a drawing in the active project so the information is saved.

---

If the Terminal Strip Editor encounters an error and is unable to start, a log file (named TSE\_Error\_<date and time>.log) is created in the same location as the project file. The log information includes details about the user name, project name, date, time, terminal strip tag, installation, and location. It also includes details about the specific terminal such as the drawing it is on, the handle of the terminal, and the issue with the terminal.

### **Wiring Constraints**

The Terminal Strip Editor can add or remove extra terminals based on the assigned wiring constraints. Wiring constraints is the limitation of the number of wires that can be connected to a particular device (for example, terminal). When modifying terminals, you can assign the number of wires allowed for each side of the terminal in the Wires Per Connection section of the Terminal Block Properties dialog box.

Extra terminals get placed only when editing a terminal using the Terminal Strip Editor. Once you define the Wires Per Connection value, the Terminal Strip Editor checks to see if there are more wires/devices connected to a side of the terminal than what is allowed. If it finds the defined constraint to exceed, the Terminal Strip Editor adds an additional terminal and moves the destination that is exceeding the constraint to the new terminal. The new terminal has the same destination, property, and catalog assignment as the original terminal. The moved destination is placed in the same level of the new terminal as it was in the original terminal. The extra terminals are reflected in the Bill of Materials.

When a terminal strip is edited with the Terminal Strip Editor, the need for extra terminals is re-evaluated and they are removed if the constraints are no longer exceeded. If the main footprint terminal is removed from the association, the extras are removed.

### **Insert a terminal strip using the Terminal Strip Editor**



- 1 Click Panel tab ► Terminal Footprints panel ► Editor.
- 2 On the Terminal Strip Selection dialog box, click New.

---

**NOTE** If you want to use the Installation, Location, and Tag Strip values from an existing terminal, select the terminal before you click New.

---

- 3 On the Terminal Strip Definition dialog box, specify the Installation code, Location code, Tag Strip value, and number of terminal blocks to define on the terminal strip.
- 4 Click OK.
- 5 Select the tab to edit: Terminal Strip, Catalog Code Assignment, Cable Information, or Layout Preview.
  - **Terminal Strip tab:** Modify the terminal block properties, spare terminals, accessories, multi-level terminals, and destination locations.
  - **Catalog Code Assignment tab:** In addition to what can be done in the Terminal Strip tab, you can assign, delete, copy, or paste catalog part numbers to terminal blocks.
  - **Cable Information tab:** View the terminal destination locations based on the cable assignments. Modify the terminal block properties, spare terminals, and terminal tag or number.
  - **Layout Preview tab:** Create graphical terminal strip or table object drawings of the selected terminal strip. You can preview the terminal strip in the Preview window before inserting the terminal strip.
- 6 On the Layout Preview tab, click Insert.
- 7 Specify the terminal strip insertion point on the drawing.

### Select a terminal strip to edit

Modifies existing or creates new terminal strips. Produces graphical or tabular representations.

Modifies an entire terminal strip or individual terminals. Assigns catalog values, resequences terminal numbers, adds jumpers and jumper charts, adds spares and accessories. Inserts or updates graphical or tabular terminal strip layouts.

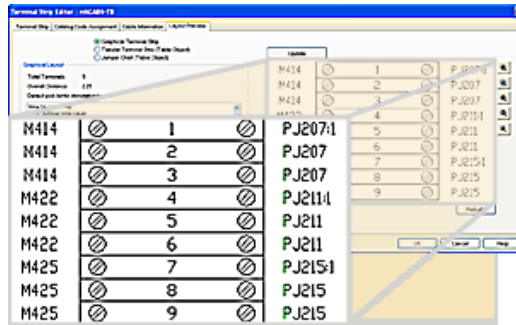

- 1 Click Panel tab ► Terminal Footprints panel ► Editor.
- 2 Select which terminal strip to edit on the Terminal Strip Selection dialog box and click Edit.
- 3 Select the tab to edit: Terminal Strip, Catalog Code Assignment, Cable Information, or Layout Preview.
  - **Terminal Strip tab:** Modify the terminal block properties, spare terminals, accessories, multi-level terminals, and destination locations.
  - **Catalog Code Assignment tab:** In addition to what can be done in the Terminal Strip tab, you can assign, delete, copy, or paste catalog part numbers to terminal blocks.
  - **Cable Information tab:** View the terminal destination locations based on the cable assignments. Modify the terminal block properties, spare terminals, and terminal tag or number.
  - **Layout Preview tab:** Create graphical terminal strip or table object drawings of the selected terminal strip. You can preview the terminal strip in the Preview window before inserting the terminal strip.
- 4 Modify the terminal strip and click OK.  
 To place the terminal strip, click Insert on the Layout Preview tab. You can also click Rebuild or Refresh to update the edited graphical or table object terminal strip in place.

## Insert a terminal strip table in multiple sections

A terminal strip table can be added through the Terminal Strip Editor or with the Terminal Strip Table Generator tool. A terminal strip can be split into multiple table sections by changing your table settings.

### Terminal Strip Editor



- 1 Click Panel tab ► Terminal Footprints panel ► Editor.
- 2 Make your selection on the Terminal Strip Selection dialog box and click Edit.
- 3 Click the Layout Preview tab.
- 4 Select Settings.
- 5 Enter the number of rows you want for each section. If the table break falls between rows within one terminal definition, the entire terminal definition is placed in the next table section. This results in a table section with fewer rows than defined.

---

**NOTE** If the terminal definition is the first one in the section and exceeds the number of rows per section, the entire terminal definition is kept together in one section.

---

- 6 Specify how many table sections you want to place on each drawing. Unless you insert all the sections on the active drawing, new drawings are created for the table sections.
- 7  Specify the X and Y placement or select the Pick Point button to pick a point on the drawing. This value is used for the first table section on each drawing.
- 8 Specify the distance you want between each section if you are placing more than one section per drawing.
- 9 Specify the direction to place each section after the first table section.
- 10 Specify the offset base point. This option indicates whether you want the distance value measured from insertion point to insertion point, or the gap between the sections.



- 11 Specify the file name for the first drawing. The last character of the file name is incremented for each new drawing.
- 12 (Optional) Specify a template file to use.
- 13 Click OK.

### Terminal Strip Table Generator

- 1 Click Panel tab ► Terminal Footprints panel ► Table Generator.



- 2 Select Settings.
- 3 Enter the number of rows you want for each section. If the table break falls between rows within one terminal definition, the entire terminal definition is placed in the next table section. This results in a table section with fewer rows than defined.

---

**NOTE** If the terminal definition is the first one in the section and exceeds the number of rows per section, the entire terminal definition is kept together in one section.

---

- 4 Specify how many table sections you want to place on each drawing. Unless you insert all the sections on the active drawing, new drawings are created for the table sections.



- 5 Specify the X and Y placement or select the Pick Point button to pick a point on the drawing. This value is used for the first table section on each drawing.
- 6 Specify the distance you want between each section if you are placing more than one section per drawing.
- 7 Specify the direction to place each section after the first table section.
- 8 Specify the offset base point. This option indicates whether you want the distance value measured from insertion point to insertion point or the gap between the sections.
- 9 Specify the file name for the first drawing. The last character of the file name is incremented for each new drawing.

10 (Optional) Specify a template file to use.

11 Click OK.

## Assign a jumper

Use this method to assign an external jumper between one or more terminals within the same terminal strip.



- 1 Click Panel tab ► Terminal Footprints panel ► Editor.
- 2 Select which terminal strip to edit on the Terminal Strip Selection dialog box and click Edit.
- 3 Select the terminal rows you wish to jumper together. If you wish to jumper to a specific level within a multi-level terminal, select the row for just that level.

---

**NOTE** The rows you select are considered one jumper and can receive only one catalog assignment.

---



- 4 Select the Assign Jumper tool.
- 5 (Optional) Enter catalog data on the Edit/Delete Jumpers dialog box.
- 6 Select OK.

---

**NOTE** Use the [Edit Jumper](#) on page 1123 tool to jumper terminals that belong to different terminal strips.

---

## Insert a jumper chart

A jumper chart is a terminal strip inserted on a drawing as a table object specifically to view jumpers within a terminal strip. An existing jumper chart is refreshed automatically when the graphical terminal strip is updated or reinserted using the Insert, Rebuild, or Refresh commands within Terminal Strip Editor or Terminal Strip Table Generator.



- 1 Click Panel tab ► Terminal Footprints panel ► Editor.
- 2 Select which terminal strip to edit on the Terminal Strip Selection dialog box and click Edit.
- 3 Select the Layout Preview tab.
- 4 Select Jumper Chart (Table Object).
- 5 Select your options:
  - **Table Style:** Select from a list of table styles.
  - **Define Columns:** Define the columns to include, column order, column titles, and the jumper circles display.
  - **Row Style:** Define specific row styles to use for the selected table style
  - **Layer:** Define the specific layer for the table.
  - **Table Title:** Define a title for the table by entering text, selecting from a list of variables, or a combination.
  - **Display:** Select what to include.
- 6 Select Insert. You can also click Rebuild or Refresh to update the jumper chart in place.

---

**NOTE** You can insert or update a jumper chart by pointing at a panel terminal, right-clicking, and selecting Insert Jumper Chart from the menu. The last saved settings for the jumper chart are used.

---

## Terminal strip selection

Displays terminal strips inside of the active project. The combination of Installation, Location, and Terminal Strip values make a complete unique record for selection in the Terminal Strip Selection dialog box.



 **Ribbon:** Panel tab ► Terminal Footprints panel ► Editor.



 **Toolbar:** Panel Layout

 **Menu:** Panel Layout ► Terminal Strip Editor

 **Command entry:** AETSE

---

**NOTE** Empty fields from the schematic display empty boxes in the selection window to indicate that no value was defined by the user in the schematic drawing.

---

Sort the entire table by selecting the individual column headers. Do any of the following:

- To edit a terminal strip, select the terminal strip and click Edit.
- To create a terminal strip, click New.
- To create a terminal strip based on an existing one, select the terminal strip and click New.

## Terminal strip definition

This dialog box controls the naming of the terminal strip, Installation and Location codes, and default options for the terminal blocks being created.

 **Ribbon:** Panel tab ► Terminal Footprints panel ► Editor.



 **Toolbar:** Panel Layout

 **Menu:** Panel Layout ► Terminal Strip Editor

 **Command entry:** AETSE



On the Terminal Strip Selection dialog box, click New.

Use the following options to create a terminal strip definition that was not placed into the schematic. Some of the properties are written to each terminal symbol on the graphical terminal strip layout drawing.

### Installation

Specifies the Installation code value for the new terminal strip. Click Browse to display a list of existing installation values found in the active drawing, entire project, or an external list (default.inst). Pick from the list to update the component automatically with the installation code.

### Location

Specifies the Location code value for the new terminal strip. Click Browse to display a list of existing

location values found in the active drawing, entire project, or an external list (default.inst). Pick from the list to update the component automatically with the location code.

**Terminal Strip**

Specifies the strip tag name for the new terminal strip. You cannot have duplicate terminal strip names in the active project.

**Number of Terminal Blocks**

Specifies the number of blocks the terminal strip is made up of. This value is not maintained on any of the terminal symbols in the graphical terminal strip layout.

If the Installation and Location values are left blank, the terminal strip is created using only the strip tag name. The Installation (INST), Location (LOC) and Tag Strip (TAG\_STRIP) values are used to determine the uniqueness of a terminal strip no matter which standard is used in the active project (such as IEC or JIC).

**Terminal strip editor: terminal strip tab**

Modifies terminal numbering, sorting, and destination settings. The terminals display in the center of the list box, with the destinations on both sides.



 **Ribbon:** Panel tab ► Terminal Footprints panel ► Editor.



 **Toolbar:** Panel Layout

 **Menu:** Panel Layout ► Terminal Strip Editor

 **Command entry:** AETSE

Make your selection on the Terminal Strip Selection dialog box and click Edit or New. Click the Terminal Strip tab.

You can sort the terminal blocks inside of the Terminal Strip Editor dialog box by selecting the column headers. The first click on the header sorts the column in ascending order. The second click sorts in descending order. The sort criteria applies to all tabs inside of the Terminal Strip Editor dialog box so you do not have to sort again if you switch between tabs.

## Terminal Listing

There are three sections to the grid: Internal Destination, Terminal Block Information, and External Destination. The bold vertical grid lines make it easier to determine the differences in these sections. The horizontal grid lines delineate between wires connected to the terminal blocks. Each row indicates one wire per side. The bold horizontal grid lines make it easier to distinguish separations between terminal blocks on the strip.

Select the terminal blocks for editing. Multiple blocks can be selected using either the Shift or Control key while highlighting rows, or by clicking and dragging the mouse.

---

**NOTE** You can right-click any row in the terminal listing to access any of the editing tools found in the button groupings at the bottom of the dialog box. You can also right-click to select or deselect all of the terminals in the strip.

---

<b>Internal Destination</b>	Displays the devices on the left side of the terminal strip.
<b>Terminal Block Information</b>	Displays the terminal block number, terminal device pin connection descriptions and jumpers. These values display in the Terminal Listing with a blue background indicating that they are associated to the terminal block. <hr/> <b>NOTE</b> Internal jumpers are indicated with squares and are on the left side. External jumpers are indicated with circles and are on the right side. <hr/>
<b>External Destination</b>	Displays the devices on the right side of the terminal strip.

A single line entry terminal block has only two wires connected with its destinations on opposing sides (left/right). Use the terminal block properties to connect more wires to the terminal block, which changes the block into a multiple-line terminal entry.

## Properties



### Edit Terminal Block Properties

Defines or edits terminal block properties. When a multi-level terminal block is selected, the properties are edited for all levels of the terminal. The defined properties are assigned to every terminal symbol in its association.

You can define up to 99 terminal levels in the block properties.



#### Copy Terminal Block Properties

Copies terminal block properties from one terminal to paste into another terminals.



#### Paste Terminal Block Properties

Pastes the previously copied terminal block properties into the selected terminals.

### Terminal



#### Edit Terminal

Modifies the selected terminal block. Any modifications to the ID (Installation, Location, Terminal Strip) removes the terminal block from its current terminal strip into the modified or newly defined terminal strip. You can perform a search of the project for current installation and location codes.



#### Reassign Terminal

Moves the highlighted terminal blocks from the active terminal strip to the terminal strip defined in the Reassign Terminal dialog box. You can perform a search of the project for current installation and location codes.



#### Renumber Terminals

Renumbers all, or a partial list, of terminal blocks from the active terminal strip. On the Renumber Terminal Strip dialog box, specify the new starting number and other options for renumbering the terminal.

---

**NOTE** You cannot renumber a terminal that uses a wire number as its terminal number. Additionally, duplicate terminal numbers are not restricted.

---



#### Move Terminal

Moves an entire terminal (including all levels and any extra terminals created due to wiring constraints) on the terminal strip. You can move the terminal block up or down in the listing or manually pick a new position on the terminal strip listing.

### Spare



#### Insert Spare Terminal

Inserts spare terminal blocks on the active terminal strip. Use the Insert Spare Terminal dialog box to define a terminal block number or name, specify the

number of spares to insert, and to insert the spare terminals previous or below the highlighted terminal. You can add up to 10,000 spare terminals into the terminal block.

---

**NOTE** Spare terminal assignments are temporary for the current session of the Terminal Strip Editor. Place the graphical terminal strip layout on the drawing during the current session if you want to keep the spare terminal assignments. You are prompted to Insert or Rebuild the terminal strip before you can exit Terminal Strip Editor.

---



**Insert Accessory**

Inserts one or more accessories (such as terminal end barriers or partitions) into the terminal strip.

---

**NOTE** Accessory terminal assignments are temporary for the current session of the Terminal Strip Editor. Place the graphical terminal strip layout on the drawing during the current session if you want to keep the accessory terminal assignments. You are prompted to Insert or Rebuild the terminal strip before you can exit Terminal Strip Editor.

---



**Delete Spare Terminals/Accessories**

Deletes the spare terminal block or accessory on the terminal strip listing.

## Destinations



**Toggle Location**

Toggles an entire location code from an Internal destination to an External destination or from an External destination to an Internal destination. You do not have to select any terminal blocks from the terminal listing.



**Toggle Installation**

Toggles an entire installation code from an Internal destination to an External destination or from an External destination to an Internal destination. You do not have to select any terminal blocks from the terminal listing.



**Toggle Terminal Destinations**

Changes the destination from Internal (left) to External (right) or from External to Internal.





#### Switch Terminal Destinations

Switches both destination values for the highlighted terminal block. The Internal destinations switch to the External (right) destinations, while all External destinations switch to Internal destinations.



#### Move Destination

Moves the destinations within the terminal/level definition. All the selected destinations are moved up or down within the level they belong to. Only the destinations for cloned blocks due to wire constraints can cross the boundary of the level they originally belong to.

### Jumpers



#### Assign Jumper

Jumpers together the selected terminals or levels.



#### Edit/Delete Jumper

Edits a catalog assignment for a jumper, removes terminals or levels from a jumper definition or deletes a jumper.

### Multi-Level



#### Associate Terminals

Combines two or more terminal blocks from any drawing into a single multiple-level terminal block. You are alerted if you select too many levels to associate. You can then decrease the number of selected levels or use the Break Apart Terminal Associations tool to separate out one of the levels in the new association.



#### Break Apart Terminal Associations

Separates one or more levels from the multiple level terminal block into separate terminal blocks. When the new terminal definitions are created, they retain the same properties as the original terminal.

- **One terminal:** Breaks the selected levels from their original association and adds them into a new association together.
- **Separate terminals:** Breaks the selected levels from their original association and adds each level into a new individual association. These levels

occupy the same level in their new terminal definition, and new terminals are assigned the same properties as the original definition from which they were originally associated in.

## Terminal strip editor: catalog code assignment tab

Modifies terminal catalog numbers. The terminals display in the center of the list box, with associated catalog number information and destinations on both sides.

 **Ribbon:** Panel tab ► Terminal Footprints panel ► Editor.



 **Toolbar:** Panel Layout



 **Menu:** Panel Layout ► Terminal Strip Editor

 **Command entry:** AETSE

Make your selection on the Terminal Strip Selection dialog box and click Edit or New. Click the Catalog Code Assignment tab.

You can sort the terminal blocks inside of the Terminal Strip Editor dialog box by selecting the column headers. The first click on the header sorts the column in ascending order. The second click sorts in descending order. The sort criteria applies to all tabs inside of the Terminal Strip Editor dialog box so you do not have to sort again if you switch between tabs.

### Terminal Listing

There are three sections to the grid: Internal Destination, Terminal Block Information, and External Destination. The bold vertical grid lines make it easier to determine the differences in these sections. The horizontal grid lines delineate between wires connected to the terminal blocks; each row indicates one wire per side. The bold horizontal grid lines make it easier to distinguish separations between terminal blocks on the strip.

Select the terminal blocks for editing. Multiple blocks can be selected using either the Shift or Control key while highlighting rows, or by clicking and dragging the mouse.

---

**NOTE** You can right-click on any row in the terminal listing to access any of the editing tools found in the button groupings at the bottom of the dialog box. You can also right-click to select or deselect all of the terminals in the strip.

---

<b>Internal Destination</b>	Displays the devices on the left side of the terminal strip.
<b>Terminal Block Information</b>	Displays the terminal block number, terminal device pin connection descriptions, jumpers, and catalog data. These values display in the Terminal Listing with a blue background indicating that they are associated to the terminal block. <hr/> <b>NOTE</b> Internal jumpers are indicated with squares and are on the left side. External jumpers are indicated with circles and are on the right side. <hr/>
<b>External Destination</b>	Displays the devices on the right side of the terminal strip.

A single line entry terminal block has only two wires connected with its destinations on opposing sides (left/right). Use the terminal block properties to connect more wires to the terminal block, which changes the block into a multiple-line terminal entry.

### Properties



#### Edit Terminal Block Properties

Defines or edits terminal block properties. When a multi-level terminal block is selected, the properties are edited for all levels of the terminal. The defined properties are assigned to every terminal symbol in its association.  
You can define up to 99 terminal levels in the block properties.



#### Copy Terminal Block Properties

Copies terminal block properties from one terminal to paste into another terminals.



#### Paste Terminal Block Properties

Pastes the previously copied terminal block properties into the selected terminals.

## Terminal



### Edit Terminal

Modifies the selected terminal block. Any modifications to the ID (Installation, Location, Terminal Strip) removes the terminal block from its current terminal strip into the modified or newly defined terminal strip. You can perform a search of the project for current installation and location codes.



### Reassign Terminal

Moves the highlighted terminal blocks from the active terminal strip to the terminal strip defined in the Reassign Terminal dialog box.



### Renumber Terminals

Renumbers all, or a partial list, of terminal blocks from the active terminal strip. On the Renumber Terminal Strip dialog box, specify the new starting number and other options for renumbering the terminal.

---

**NOTE** You cannot renumber a terminal that uses a wire number as its terminal number. Additionally, duplicate terminal numbers are not restricted.

---



### Move Terminal

Moves an entire terminal (including all levels and any extra terminals created due to wiring constraints) on the terminal strip. You can move the terminal block up or down in the listing or manually pick a new position on the terminal strip listing.

## Spare



### Insert Spare Terminal

Inserts spare terminal blocks on the active terminal strip. Use the Insert Spare Terminal dialog box to define a terminal block number or name, specify the number of spares to insert, and to insert the spare terminals previous or below the highlighted terminal. You can add up to 10,000 spare terminals into the terminal block.

---

**NOTE** Spare terminal assignments are temporary for the current session of the Terminal Strip Editor. Place the graphical terminal strip layout on the drawing during the current session if you want to keep the spare terminal assignments. You are prompted to Insert or Rebuild the terminal strip before you can exit Terminal Strip Editor.

---



**Insert Accessory**

Inserts one or more accessories (such as terminal end barriers or partitions) into the terminal strip.

---

**NOTE** Accessory terminal assignments are temporary for the current session of the Terminal Strip Editor. Place the graphical terminal strip layout on the drawing during the current session if you want to keep the accessory terminal assignments. You are prompted to Insert or Rebuild the terminal strip before you can exit Terminal Strip Editor.

---



**Delete Spare Terminals/Accessories**

Deletes the spare terminal block or accessory on the terminal strip listing.

### Destinations



**Toggle Location**

Toggles an entire location code from an Internal destination to an External destination or from an External destination to an Internal destination. You do not have to select any terminal blocks from the terminal listing.



**Toggle Installation**

Toggles an entire installation code from an Internal destination to an External destination or from an External destination to an Internal destination. You do not have to select any terminal blocks from the terminal listing.



**Toggle Terminal Destinations**

Changes the destination from Internal (left) to External (right) or from External to Internal.



**Switch Terminal Destinations**

Switches both destination values for the highlighted terminal block. The Internal destinations switch to the



### Move Destination

External (right) destinations, while all External destinations switch to Internal destinations.

Moves the destinations within the terminal/level definition. All the selected destinations are moved up or down within the level they belong to. Only the destinations for cloned blocks due to wire constraints can cross the boundary of the level they originally belong to.

## Jumpers



### Assign Jumper

Jumpers together the selected terminals or levels.



### Edit/Delete Jumper

Edits a catalog assignment for a jumper, removes terminals or levels from a jumper definition or deletes a jumper.

## Multi-Level



### Associate Terminals

Combines two or more terminal blocks from any drawing into a single multiple-level terminal block. You are alerted if you select too many levels to associate. You can then decrease the number of selected levels or use the Break Apart Terminal Associations tool to separate out one of the levels in the new association.



### Break Apart Terminal Associations

Separates one or more levels from the multiple level terminal block into separate terminal blocks. When the new terminal definitions are created, they retain the same properties as the original terminal.

- **One terminal:** Breaks the selected levels from their original association and adds them into a new association together.
- **Separate terminals:** Breaks the selected levels from their original association and adds each level into a new individual association. These levels occupy the same level in their new terminal definition, and new terminals are assigned the

same properties as the original definition from which they were originally associated in.

## Catalog



### Assign Catalog Number

Assigns catalog part numbers to the selected terminal blocks, spare terminals, or accessories. The catalog number assignments are written back to the schematic and panel drawings. It displays the Parts Catalog dialog box. Once the catalog number is selected from the Parts Catalog dialog box, the Catalog Manufacturer and Part Number are entered into the Terminal Strip Editor dialog box.



### Delete Catalog Number

Removes the catalog part numbers previously assigned to terminal block, spare terminal, or accessory (either within the Terminal Strip Editor or the schematic drawing).



### Copy Catalog Number

Copies catalog part numbers of one terminal to paste to other terminal blocks within the Terminal Strip Editor.



### Paste Catalog Number

Pastes catalog part numbers (and terminal block properties) of one terminal to another single terminal or multiple terminal blocks within the Terminal Strip Editor.

## Terminal strip editor: cable information tab

Displays cable previews for terminal blocks. The terminals are displayed in the center of the list box with the cable name, wire conductor information, and device destination information on both sides.



 **Ribbon:** Panel tab ► Terminal Footprints panel ► Editor.



 **Toolbar:** Panel Layout

 **Menu:** Panel Layout ► Terminal Strip Editor

 **Command entry:** AETSE

Make your selection on the Terminal Strip Selection dialog box and click Edit or New. Click the Cable Preview tab.

You can sort the terminal blocks inside of the Terminal Strip Editor dialog box by selecting the column headers. The first click on the header sorts the column in ascending order. The second click sorts in descending order. The sort criteria applies to all tabs inside of the Terminal Strip Editor dialog box so you do not have to sort again if you switch between tabs.

### Terminal Listing

There are three sections to the grid: Internal Destination, Terminal Block Information, and External Destination. The bold vertical grid lines make it easier to determine the differences in these sections. The horizontal grid lines delineate between wires connected to the terminal blocks; each row indicates one wire per side. The bold horizontal grid lines make it easier to distinguish separations between terminal blocks on the strip.

Select the terminal blocks for editing. Multiple blocks can be selected using either the Shift or Control key while highlighting rows, or by clicking and dragging the mouse.

---

**NOTE** You can right-click on any row in the terminal listing to access any of the editing tools found in the button groupings at the bottom of the dialog box. You can also right-click to select or deselect all of the terminals in the strip.

---

<b>Internal Destination</b>	Displays the devices on the left side of the terminal strip.
<b>Terminal Block Information</b>	Displays the terminal block number, terminal device pin connection descriptions, jumpers, and cable information. These values display in the Terminal Listing with a blue background indicating that they are associated to the terminal block. <hr/> <b>NOTE</b> Internal jumpers are indicated with squares and are on the left side. External jumpers are indicated with circles and are on the right side.
<b>External Destination</b>	Displays the devices on the right side of the terminal strip.

A single line entry terminal block has only two wires connected with its destinations on opposing sides (left/right). Use the terminal block properties to connect more wires to the terminal block, which changes the block into a multiple-line terminal entry.



## Properties



### Edit Terminal Block Properties

Defines or edits terminal block properties. When a multi-level terminal block is selected, the properties are edited for all levels of the terminal. The defined properties are assigned to every terminal symbol in its association.

You can define up to 99 terminal levels in the block properties.



### Copy Terminal Block Properties

Copies terminal block properties from one terminal to paste into another terminal.



### Paste Terminal Block Properties

Pastes the previously copied terminal block properties into the selected terminals.

## Terminal



### Edit Terminal

Modifies the selected terminal block. Any modifications to the ID (Installation, Location, Terminal Strip) removes the terminal block from its current terminal strip into the modified or newly defined terminal strip. You can perform a search of the project for current installation and location codes.



### Reassign Terminal

Moves the highlighted terminal blocks from the active terminal strip to the terminal strip defined in the Reassign Terminal dialog box.



### Renumber Terminals

Renumbers all, or a partial list, of terminal blocks from the active terminal strip. On the Renumber Terminal Strip dialog box, specify the new starting number and other options for renumbering the terminal.

---

**NOTE** You cannot renumber a terminal that uses a wire number as its terminal number. Additionally, duplicate terminal numbers are not restricted.

---



### Move Terminal

Moves an entire terminal (including all levels and any extra terminals created due to wiring constraints) on the terminal strip. You can move the terminal block

up or down in the listing or manually pick a new position on the terminal strip listing.

## Spare



**Insert Spare Terminal**

Inserts spare terminal blocks on the active terminal strip. Use the Insert Spare Terminal dialog box to define a terminal block number or name, specify the number of spares to insert, and to insert the spare terminals previous or below the highlighted terminal. You can add up to 10,000 spare terminals into the terminal block.

---

**NOTE** Spare terminal assignments are temporary for the current session of the Terminal Strip Editor. Place the graphical terminal strip layout on the drawing during the current session if you want to keep the spare terminal assignments. You are prompted to Insert or Rebuild the terminal strip before you can exit Terminal Strip Editor.

---



**Insert Accessory**

Inserts one or more accessories (such as terminal end barriers or partitions) into the terminal strip.

---

**NOTE** Accessory terminal assignments are temporary for the current session of the Terminal Strip Editor. Place the graphical terminal strip layout on the drawing during the current session if you want to keep the accessory terminal assignments. You are prompted to Insert or Rebuild the terminal strip before you can exit Terminal Strip Editor.

---



**Delete Spare Terminals/Accessories**

Deletes the spare terminal block or accessory on the terminal strip listing.

## Destinations



**Toggle Location**

Toggles an entire location code from an Internal destination to an External destination or from an External destination to an Internal destination. You do not have to select any terminal blocks from the terminal listing.



#### Toggle Installation

Toggles an entire installation code from an Internal destination to an External destination or from an External destination to an Internal destination. You do not have to select any terminal blocks from the terminal listing.



#### Toggle Terminal Destinations

Changes the destination from Internal (left) to External (right) or from External to Internal.



#### Switch Terminal Destinations

Switches both destination values for the highlighted terminal block. The Internal destinations switch to the External (right) destinations, while all External destinations switch to Internal destinations.



#### Move Destination

Moves the destinations within the terminal/level definition. All the selected destinations are moved up or down within the level they belong to. Only the destinations for cloned blocks due to wire constraints can cross the boundary of the level they originally belong to.

### Jumpers



#### Assign Jumper

Jumpers together the selected terminals or levels.



#### Edit/Delete Jumper

Edits a catalog assignment for a jumper, removes terminals or levels from a jumper definition or deletes a jumper.



### Terminal strip editor: layout preview tab

Controls a preview display of the terminal strip in graphical or tabular layout. It helps determine the best way to generate a terminal layout before placing the image on the drawing file.



 **Ribbon:** Panel tab ► Terminal Footprints panel ► Editor.



-  **Toolbar:** Panel Layout
-  **Menu:** Panel Layout ► Terminal Strip Editor
-  **Command entry:** AETSE

Make your selection on the Terminal Strip Selection dialog box and click Edit or New. Click the Layout Preview tab.

### Graphical Terminal Strip/Table Object Terminal Strip/Jumper Chart

Specifies the type of terminal strip to generate. The dialog box options change depending on whether you are creating a graphical, tabular, or jumper chart type of terminal strip.

You can insert an AutoCAD table object as a tabular terminal strip. It allows for more accurate representations of what is in the Terminal Strip Editor, more flexibility with the look and style, and provides a means of automatic updating.

You can insert a jumper chart which is an AutoCAD table object representing the terminal strip with certain columns pre-defined to include any jumpers defined.

### Graphical Layout

Generates a graphical representation including terminal footprints, terminal numbers, wiring information, and terminal destination information.

<b>Total Terminals</b>	Displays the total number of terminal block symbols needed to create the terminal strip layout.
<b>Overall Distance</b>	Displays the overall distance the terminal strip footprint takes up when placed on the active drawing.
<b>Default pick list for Annotation format</b>	Lists some common formatting types. You are not limited to the selections provided by the default pick list. The replaceable parameter variables can be displayed in any combination including hard-coded characters such as dashes, brackets, and parenthesis.
<b>Annotation Format</b>	Determines the formatting of the wiring information associated with the terminal destination. You can define variable information to display the contents of the Terminal Strip Editor. One field is for the left-hand side, while the other is for the right-hand side of the terminal footprint.

---

**NOTE** You can leave this field blank if you do not want the annotation format added to the preview.

---

**Scale on Insert**

Specifies the scale to use when inserting the graphical representation onto the drawing file.

**Angle on Insert**

Specifies the angle to use when inserting the graphical representation onto the drawing file. Select from the list of pre-defined angles.

---

**NOTE** The angle and scale values are reflected in the preview.

---

**Tabular Layout for a Table Object**

The following options are available if you selected to create a Tabular Terminal Strip (Table Object).

**Table Style**

Specifies the table style to use for the tabular report. Select from the list or click Browse to browse to and select another drawing file whose table styles you want to use.

---

**NOTE** If the selected table style is not in the TableStyle.dwg file, it is added.

---

**Define Columns**

Defines the [columns](#) on page 1110 to include, order, headings, justification, and jumper circles display for the tabular report.

**Row Styles**

Defines specific row styles to use for the selected table style. On the Select Row Cell Styles dialog box, select the table style and row cell styles to use and click OK.

**Layer**

Defines the specific layer for the tabular terminal strip to place on when inserted. On the Select Table Layer dialog box, select the layer name from the list of layers on the active drawing and click OK.

**Table Title**

Defines a title for the table. Enter a title, select from a list of variables or use a combination of both. When selecting from the list, the selection is added to the end of the string if one exists in the edit box.

<b>Total Rows</b>	Displays the total number of rows needed to create the terminal strip table layout. For example, even though the terminal strip contains only 86 terminals, the table format may present more rows in a multi-line terminal situation.
<b>Number of Rows per Section</b>	Displays the number of rows per section as defined on the Table Settings dialog box.
<b>Number of Sections</b>	Displays the number of sections needed based on the total rows and the number of rows per section.
<b>Number of Sections per Drawing</b>	Displays the number of sections to place on each drawing as defined on the Table Settings dialog box.
<b>Number of Drawings</b>	Displays the number of drawings necessary to generate the terminal strips using the current table settings.
<b>Settings</b>	Defines the <a href="#">table settings</a> on page 1093 such as number of rows per section, number of sections per drawing, table, and section placement, section offset, scale, angle, first drawing name if a new drawing is needed, and the template to use for any new drawings generated.
<b>Browse</b>	Browses for any saved settings (in a *.tsl file) that you previously created.
<b>Save As</b>	Saves the settings to an external file (with extension *.tsl) that you can later reuse. The default folder location is the User folder in the Documents and Settings or Users location.
<b>Default</b>	Uses the default settings for creating the tabular report.
<b>Drawing to Preview</b>	Slides to change which drawing to preview if your table settings define a multi-section table that spans multiple drawings.

---

**NOTE** All table sections are inserted or updated, not just the table sections in the drawing preview.

---

---

**NOTE** The selections are stored in the table when it is inserted and the next time the terminal strip is edited, the settings are read back in.

---

### **Jumper Chart**

The following options are available if you selected to create a Jumper Chart (Table Object).

<b>Table Style</b>	Specifies the table style to use for the tabular report. Select from the list or click Browse to browse to and select another drawing file whose table styles you want to use. <hr/> <b>NOTE</b> If the selected table style is not in the TableStyle.dwg file, it is added. <hr/>
<b>Define Columns</b>	Defines the columns to include, order, headings, justification, and jumper circles display for the jumper chart.
<b>Row Styles</b>	Defines specific row styles to use for the selected table style. On the Select Row Cell Styles dialog box, select the table style and row cell styles to use and click OK.
<b>Layer</b>	Defines the specific layer for the tabular terminal strip be place on when inserted. On the Select Table Layer dialog box, select the layer name from the list of layers on the active drawing and click OK.
<b>Table Title</b>	Defines a title for the table. Enter a title, select from a list of variables or use a combination of both. When selecting from the list, the selection is added to the end of the string if one exists in the edit box.
<b>Display all terminals and accessories</b>	Include all terminals and accessories for the terminal strip in the table.

<b>Display only jumpered terminals and accessories</b>	Include only the terminals that are jumpered and all accessories for the terminal strip in the table, leaving out any terminals that are not jumpered.
<b>Display only jumpered terminals</b>	Include only the terminals that are jumpered in the table, leaving out all accessories and any terminals that are not jumpered.
<b>Show Unused Wire Connections in Table</b>	Select to display all rows for each terminal even if there is no connected component. The number of rows is defined by the Wires per Connection value for the terminal. <hr/> <b>NOTE</b> A terminal without any connected components has one row in the table. <hr/>
<b>Scale/Angle on Insert</b>	Specifies the scale and angle of the table sections when inserted. These settings are reflected in the preview.
<b>Save</b>	Saves the settings to the file, JumperChart.tjc, that is used whenever a jumper chart is inserted or rebuilt. The folder location is the User folder which by default is in the Documents and Settings or Users folder.
<b>Default</b>	Uses the default settings for creating the jumper chart.

You can also insert or refresh a jumper chart from the right-click menu. Select a panel terminal, right-click, and select Insert Jumper Chart. If there is an existing jumper chart for the terminal strip a dialog box opens. Select Insert or Refresh from the dialog box. Pick an insertion point if you are inserting the jumper chart.

### **Update**

Refreshes the preview window with any changes made with the preview controls or the Terminal Strip Editor. If you modify the settings for the output, you can refresh the preview.



Use icons or the right-click menu to zoom and pan inside of the preview window.



**Zoom In**

Increases the apparent size of the objects in the preview.



**Zoom Out**

Decreases the apparent size of the objects in the preview.



**Zoom Extents**

Zooms to display the terminal strip extents.



**Zoom Original**

Restores the original view.



**Zoom Window**

Zooms to display an area specified by a rectangular window.

### **Insert**

Places the terminal strip.

### **Rebuild**

Updates an existing terminal strip that was previously inserted by the Terminal Strip Editor in place. If the terminal strip exists in the project, the terminal strip is located, deleted and rebuilt in place without prompting you to select a new insertion point.

### **Refresh**

(Not available for graphical terminal strips.) Refreshes the data within an existing tabular terminal strip. A new table is not inserted.

## **Terminal strip table settings**

Defines the settings for the Terminal Strip table object.

### Terminal Strip Editor

 **Ribbon:** Panel tab ► Terminal Footprints panel ► Editor.

 **Toolbar:** Panel Layout

 **Menu:** Panel Layout ► Terminal Strip Editor

 **Command entry:** AETSE

Make your selection on the Terminal Strip Selection dialog box and click Edit. Click the Layout Preview tab and select Tabular Terminal Strip (Table Object). Click Settings.

### Terminal Strip Table Generator

 **Ribbon:** Panel tab ► Terminal Footprints panel ► Table Generator.

 **Toolbar:** Terminal Footprint

 **Menu:** Panel Layout ► Terminal Strip Table Generator

 **Command entry:** AETSEGENERATOR

#### Rows Per Section

Specifies how many rows for each table section. If the table break falls between rows within one terminal definition, the entire terminal definition is placed in the next table section. This results in a table section with fewer rows than defined.

---

**NOTE** If the terminal definition is the first one in the section and exceeds the number of rows per section, the entire terminal definition is kept together in one section.

---

#### Sections Per Drawing

Specifies how many table sections to insert on each drawing. All sections are placed on new drawings

unless the option “Insert All Sections on Active Drawing” is selected.

---

**NOTE** The “Insert All Sections on Active Drawing” option is not available when using the Terminal Strip Table Generator tool.

---

**Section Placement**

Specifies where to place the table in the drawing. You can enter x and y values or pick a point on the screen.

**Section Offset**

Specifies the distance between sections, offset direction, and the base point for the distance measurement.

- **Distance:** Specifies the distance between sections.
- **Direction:** Specifies the direction for the offset.
- **Base Point:** Specifies the base point for the distance measurement between sections.

**Scale/Angle on Insert**

Specifies the scale and angle of the table sections when inserted. These settings are reflected in the preview.

**Drawing Information for Table Output**

- **First Drawing Name:** Specifies a starting drawing file location and file name to use for the automatic creation of the drawing files. The drawings are automatically added to the active project and display at the end of the drawing list in the Project Manager. The last character of the drawing file name is incremented for each drawing created.
- **Template:** Specifies the template file to use for any new drawings. Enter a template file name or click Browse to search for and select a template file.

**Show Unused Wire Connections in Table**

Select to display all rows for each terminal even if there is no connected component. The Wires per Connection value for the terminal defines the number of rows.

Preview

---

**NOTE** A terminal without any connected components has one row in the table.

---

Opens a preview dialog box to view each drawing as it will look when generated. All table settings are reflected in the preview.

## Terminal block properties

Use this dialog box to control the number of levels assigned to a multiple level terminal block. You can control the level description, number of wires per connection, pins right, pins left and internal jumpers. The terminal block properties are maintained on every terminal symbol in its association.

### Insert Component

 **Ribbon:** Schematic tab ► Insert Components panel ► Insert Components

drop-down ► Icon Menu.

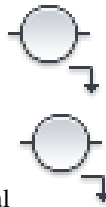

 **Toolbar:** Main Electrical

 **Menu:** Components ► Insert Component

 **Command entry:** AECOMPONENT

Select Terminals and Connectors from the dialog box and specify the insertion point on the drawing. In the Insert/Edit Terminal Symbol dialog box, click Block Properties.

### Edit Component

 **Ribbon:** Schematic tab ► Edit Components panel ► Edit Components

drop-down ► Edit.

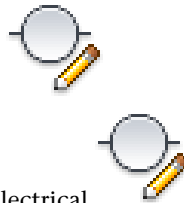

 **Toolbar:** Main Electrical

 **Menu:** Components ► Edit Component

 **Command entry:** AEEDITCOMPONENT

Select the terminal to edit. In the Insert/Edit Terminal Symbol dialog box, click Block Properties.

---

**NOTE** You can also access this dialog box by clicking Edit Terminal Block Properties on the Terminal Strip Editor dialog box.

---

The default level for any terminal symbol that is placed into the project that is not associated to another is 0.

<b>Manufacturer</b>	Displays the Manufacturer value that is currently assigned to the terminal being edited.
<b>Catalog Number</b>	Displays the Catalog Number value that is currently assigned to the terminal being edited.
<b>Assembly Code</b>	Displays the Assembly Code value that is currently assigned to the terminal being edited.
<b>Levels</b>	Specifies the number of levels for the terminal. The grid expands for editing based on the number of levels specified. You can then define the level description, wires per connection and pins.
<b>Terminal Block Property Definition grid</b>	<p>Displays the terminal levels. You can edit and maintain properties of the terminal block here.</p> <ul style="list-style-type: none"><li>■ <b>Level Description:</b> Specifies the description for the levels of the terminal block. Text you enter here displays in the Insert/Edit Terminal Symbol and Terminal Block Properties dialog boxes. This value is a terminal property that is maintained on every symbol in its association.</li><li>■ <b>Wires per Connection:</b> Specifies the number of wires allowed per connection for the terminal connection point.</li></ul> <hr/> <p><b>NOTE</b> These properties do not limit the number of connections allowed on the schematic.</p> <hr/> <ul style="list-style-type: none"><li>■ <b>Pin Left/Pin Right:</b> Specifies labels for pin numbers associated to the terminal destinations. These fill in the LnnPINL and LnnPINR attributes on the terminal block when its level is selected. This value is a terminal property that is maintained on every symbol in its association.</li><li>■ <b>Internal Jumper:</b> Graphically indicates internal jumpers assigned between levels.</li></ul>



Internally jumper the levels currently selected in the grid.



Delete the internal jumper currently assigned to the levels selected in the grid

#### Clear

Clears all terminal block properties.

---

**NOTE** Properties for a level cannot be cleared if there is a schematic terminal representing that level (other than the terminal being edited), or there is an external jumper on that level.

---

### Terminal block property attributes

The values in the grid are stored as follows. The “nn” represents the level number and is always stored as two digits (that is, 01, 02, and so on):

Data	Attribute
Level Description (60 characters maximum)	LnnLABEL
Wires Per Connection (three characters maximum)	LnnWIREPERC
Pin Left (12 characters maximum)	LnnPINL
Pin Right (12 characters maximum)	LnnPINR
Internal Jumper (255 characters maximum)	LnnINJUMP

---

**NOTE** If these attributes are not present, the data is placed into Xdata with the same name, only with a “VIA\_WD\_” prefix.

---

### Edit terminal

Edits individual terminals/levels.



 **Ribbon:** Panel tab ► Terminal Footprints panel ► Editor.



 **Toolbar:** Panel Layout

 **Menu:** Panel Layout > Terminal Strip Editor

 **Command entry:** AETSE

Make your selection on the Terminal Strip Selection dialog box and click Edit. On the Terminal Strip, Catalog Code Assignment, or Cable Information tab, select the level to modify. In the Terminals section, click Edit Terminal.

<b>Installation Code</b>	Changes the installation codes. Click Browse to display a list of existing installation values found in the active drawing, entire project, or an external list (default.inst). Pick from the list to update the component automatically with the installation code.
<b>Location Code</b>	Changes the location codes. Click Browse to display a list of existing location values found in the active drawing, entire project, or an external list (default.inst). Pick from the list to automatically update the component automatically with the location code.
<b>Terminal Strip</b>	Specifies the Tag ID given to the terminal strip. If there is an existing name, it appears in the edit box. If not, you can enter a specific ID name or click the < and > buttons to increment or decrement the last digit/character in the Tag Strip value.
<b>Number</b>	Specifies the ID number for the terminal. If the catalog values of the terminal carry PINLIST information, you can step through the available pin numbers using < or >. If there is not PINLIST information, these buttons just increment or decrement the terminal number. You can also click Pick to select a text object or an attribute on the active drawing to use for the terminal number. When inserting a new terminal, the highest terminal number in the strip is identified and the default terminal number for the new terminal increments by 1.

---

**NOTE** It is unavailable when the terminal symbol does not have a TERM01 attribute or when the terminal number is the same as the wire number.

---

---

**NOTE** Installation Code, Location Code, and Terminal Strip are disabled when editing an accessory.

---

## Reassign terminal

Reassigns the selected terminals to another terminal strip within the active project. Multiple selection is allowed.

---

**NOTE** Any terminal strips that have terminals added or removed using the Reassign Terminal tool must be inserted on the drawing or rebuilt. If you did not update the graphical terminal strip layout for the edited strip, you are prompted to select the appropriate action from the alert dialog box.

---

 **Ribbon:** Panel tab ► Terminal Footprints panel ► Editor.



 **Toolbar:** Panel Layout



 **Menu:** Panel Layout ► Terminal Strip Editor

 **Command entry:** AETSE

Make your selection on the Terminal Strip Selection dialog box and click Edit. On the Terminal Strip, Catalog Code Assignment, or Cable Information tab, select the terminal to modify. In the Terminals section, click Reassign Terminal.

The default values are representative of the current terminal strip assignment. As you select terminal strips in the grid, the values in the text boxes update to reflect your selection. If you enter your own values and a matching terminal strip does not currently exist, a new one is created.

### Installation Code

Specifies the Installation code for the selected terminal. If there is an existing name, it appears in the edit box. If not, you can enter a new value. Click Browse to display a list of existing installation values found in the active drawing, entire project, or an external list (default.inst). Pick from the list to update the component automatically with the installation code.



<b>Location Code</b>	Specifies the Location code for the selected terminal. If there is an existing name, it appears in the edit box. If not, you can enter a new value. Click Browse to display a list of existing location values found in the active drawing, entire project, or an external list (default.inst). Pick from the list to update the component automatically with the location code.
<b>Terminal Strip</b>	Specifies the Tag ID given to the terminal strip. If there is an existing name, it appears in the edit box. If not, you can enter a new value.



## Renumber terminal strip

Renumbers terminals within a terminal strip. You are prompted to insert the graphical terminal strip if you renumber a terminal that has one or more levels still available.

---

**NOTE** You cannot renumber a terminal that uses a wire number as its terminal number. Additionally, duplicate terminal numbers are not restricted.

---

 **Ribbon:** Panel tab ► Terminal Footprints panel ► Editor. 

 **Toolbar:** Panel Layout

 **Menu:** Panel Layout ► Terminal Strip Editor

 **Command entry:** AETSE

Make your selection on the Terminal Strip Selection dialog box and click Edit. On the Terminal Strip, Catalog Code Assignment, or Cable Information tab, select the level to modify. In the Terminals section, click Renumber Terminals.

<b>Terminal Renumber starting with</b>	Defines the starting value for the terminal numbers. This value can be alpha, numeric, or a combination of both. The default value is the lowest value of the selected terminals.
<b>Start with Bottom Level</b>	Indicates to process the terminals starting with the last level and work its way back to 1, in order (5,4,3,2,1). If unselected, the tool starts with level 1 and moves forward (1,2,3,4,5).

<b>Ignore Alphanumeric Terminals</b>	Indicates to process only the terminals that are a numeric value, all terminals containing an alpha character are ignored and are not renumbered.
<b>Ignore Accessories</b>	Indicates to ignore any accessories in the terminal strip during the renumber command.
<b>Renumber</b>	Specifies whether to renumber the terminal based on terminal or level. Per Terminal processes the entire terminal at a time while Per Level processes each level at a time.

## Insert spare terminal

Adds spare terminals to the edited terminal strip.



 **Ribbon:** Panel tab ► Terminal Footprints panel ► Editor.



 **Toolbar:** Panel Layout

 **Menu:** Panel Layout ► Terminal Strip Editor

 **Command entry:** AETSE

Make your selection on the Terminal Strip Selection dialog box and click Edit. On the Terminal Strip, Catalog Code Assignment, or Cable Information tab, select a terminal from the list. In the Spare section, click Insert Spare Terminal.

<b>Number</b>	Defines the starting terminal number for inserting spares. The default value is "SPARE." Select Increment if you want to increment the terminal ID when the spare terminal is inserted. If the quantity is set to less than 2, you cannot increment the ID. If you are inserting multi-level terminals as defined by the catalog assignment, each level of a terminal receives the same number assignment if you select Increment. For example, if you insert 3 spare terminals and they are defined as three level terminals, all three levels on terminal 1 are designated as 1, 2 as 2, and 3 as 3. To modify them, edit the spare terminal or use the Renumber Terminals tool to get the numbering format you want.
---------------	---

<b>Quantity</b>	Specifies a numeric value for the number of spare terminals to insert. The default value is 1. Use < or > to increment the value by a single step.
<b>Manufacturer</b>	Lists the manufacturer number for the spare terminal. Enter a value or select one from the Catalog lookup.
<b>Catalog</b>	Lists the catalog number for the spare terminal. Enter a value or select one from the Catalog lookup.
<b>Assembly</b>	Lists the assembly code for the spare terminal. The Assembly code is used to link multiple part numbers together.
<b>Catalog Lookup</b>	Opens the catalog database of the spare terminal from which you can manually enter or select the Manufacturer or Catalog values. Search the database for a specific catalog item to assign to the selected spare terminal.
<b>Insert Above/Insert Below</b>	Once you define the starting number and the number of spare terminals to insert, click Insert Above to insert the defined spare terminals above the selected terminal in the grid, or Insert Below to insert the spares below the selected terminal.

## Insert accessory

Inserts terminal accessories such as end barriers and dividers, into the terminal strip.

 **Ribbon:** Panel tab ► Terminal Footprints panel ► Editor.

 **Toolbar:** Panel Layout

**Menu:** Panel Layout ► Terminal Strip Editor

**Command entry:** AETSE

Make your selection on the Terminal Strip Selection dialog box and click Edit. On the Terminal Strip, Catalog Code Assignment, or Cable Information tab, select the terminal in the list. In the Spare section, click Insert Accessory.

<b>Number</b>	Defines the starting terminal number for inserting accessories. Select Increment if you want to increment the terminal ID when the accessory is inserted. If the quantity is set to less than 2, you cannot increment the ID.
<b>Quantity</b>	Specifies a numeric value for the number of accessories to insert. The default value is 1. Use < or > to increment the value by a single step.
<b>Manufacturer</b>	Lists the manufacturer number for the accessory. Enter a value or select one from the Catalog lookup.
<b>Catalog</b>	Lists the catalog number for the accessory. Enter a value or select one from the Catalog lookup.
<b>Assembly</b>	Lists the assembly code for the accessory. The Assembly code is used to link multiple part numbers together.
<b>Catalog Lookup</b>	Opens the catalog database of the accessory from which you can manually enter or select the Manufacturer or Catalog values. Search the database for a specific catalog item to assign to the selected accessory.
<b>Insert Above/Insert Below</b>	Once you define the starting number and the number of accessories to insert, click Insert Above to insert the defined accessories above the selected terminal in the grid, or Insert Below to insert the accessories below the selected terminal.

## Toggle location codes

Toggles destinations based on their location codes from one side of the terminal to the other.

 **Ribbon:** Panel tab ► Terminal Footprints panel ► Editor.





- Toolbar:** Panel Layout
- Menu:** Panel Layout > Terminal Strip Editor
- Command entry:** AETSE

Make your selection on the Terminal Strip Selection dialog box and click Edit. On the Terminal Strip, Catalog Code Assignment, or Cable Information tab, Destinations section, click Toggle Location.

---

**NOTE** If components are present that have a blank value for the location code, question marks (??) display in the dialog box.

---

<b>Internal Destination</b>	Lists connections to the terminal that reside in the same location as the terminal.
<b>External Destination</b>	Lists connections to the terminal that reside in a different location than the terminal.
<b>Toggle External to Internal/Toggle Internal to External</b>	Toggles/moves locations from one side of the terminal to the other. Select the location value to move in either list and click the appropriate button.

## Toggle installation code

Toggles destinations based on their installation codes from one side of the terminal to the other.



- Ribbon:** Panel tab > Terminal Footprints panel > Editor.



- Toolbar:** Panel Layout
- Menu:** Panel Layout > Terminal Strip Editor
- Command entry:** AETSE

Make your selection on the Terminal Strip Selection dialog box and click Edit. On the Terminal Strip, Catalog Code Assignment, or Cable Information tab, Destinations section, click Toggle Installation.

---

**NOTE** If components are present that have a blank value for the installation code, question marks (??) displays in the dialog box.

---

<b>Internal Destination</b>	Lists connections to the terminal that reside in the same location as the terminal.
<b>External Destination</b>	Lists connections to the terminal that reside in a different location than the terminal.
<b>Toggle External to Internal/Toggle Internal to External</b>	Toggles/moves locations from one side of the terminal to the other. Select the installation value to move in either list and click the appropriate button.

## Associate terminals

Use this tool to combine two or more terminal blocks from any drawing into a single multiple-level terminal block. You are alerted if you select too many levels to associate. You can then decrease the number of selected levels or use the Break Apart Terminal Associations tool to separate out one of the levels in the new association.

 **Ribbon:** Panel tab ► Terminal Footprints panel ► Editor.



 **Toolbar:** Panel Layout



 **Menu:** Panel Layout ► Terminal Strip Editor

 **Command entry:** AETSE

Make your selection on the Terminal Strip Selection dialog box and click Edit. On the Terminal Strip or Catalog Code Assignment tab, select the level to modify. In the Multi-Level section, click Associate Terminals.

The number of levels you selected to add to the association displays at the top of the dialog box.

<b>Terminals</b>	Lists only the terminals that have enough available levels that can accommodate the number of levels you chose to associate.
<b>Terminal grid</b>	Displays the terminal information for the terminal selected in the tree control.

- Level numbering: Displays a level number for each level that is defined in the terminal properties. The level numbering of the panel symbol is a pound symbol (#).
- Label: Lists the level description defined in the terminal block properties.
- Number: Lists the terminal numbers defined in the association. Only one terminal number is allowed per level and each level displays its respective terminal number or text. Panel terminal symbols do not display terminal numbers. Terminal levels with an assignment and a terminal that was not assigned a terminal number display question marks (???) in this column.
- PinL: Lists the pin numbers defined on the left side of the terminal block. This data is entered into the L0nPINL attribute if present; otherwise, it is placed into xdata.
- PinR: Lists the pin numbers defined on the right side of the terminal block. This data is entered into the L0nPINR attribute if present; otherwise, it is placed into xdata.  
Pin numbering is related to the terminal level and not the terminal tag number instance.
- Reference: Lists the reference location of the terminal symbol in the project. The syntax is "Sheet,Reference" based on the drawing configuration.

## Associate

Adds the selected terminal symbol to the terminal association selected on the Terminal Strip Editor dialog box. The selections are processed from top to bottom in the Terminal Strip Editor grid and populate the available levels in the new association from the first available once you click OK.

---

**NOTE** The grid row must be selected before you can perform the association.

---

Move Up/Move Down

Moves the selected terminal up or down one level within the terminal definition.

## Edit/Delete Jumpers

Use this to edit the jumper information, such as catalog data, remove terminals from a jumper, or delete a jumper.



 **Ribbon:** Panel tab ► Terminal Footprints panel ► Editor.



 **Toolbar:** Panel Layout

 **Menu:** Panel Layout ► Terminal Strip Editor

 **Command entry:** AETSE

Make your selection on the Terminal Strip Selection dialog box and click Edit. Select the terminals with the jumper defined and select the Edit/Delete Jumper tool.

Jumpers to Terminals

Lists all of the jumpers, grouped by Jumper ID, attached to the selected terminal. If this dialog box is used within the Assign Jumper function, only the jumper being assigned is displayed.

---

**NOTE** You cannot assign a jumper between terminals from different terminal strips using Terminal Strip Editor. If a jumper across terminals strips exists, it is displayed but you cannot modify it using Terminal Strip Editor. It must be modified using the [Edit Jumper](#) on page 1123 tool.

---

Catalog Data

Specifies the catalog data for the jumper between the primary terminal and the selected terminal.

- **Manufacturer:** Specifies the manufacturer name.
- **Catalog:** Specifies the catalog number.
- **Assembly:** Specifies the assembly code.
- **Item:** Specifies the item value.
- **Count:** Specifies how the catalog data is used in the Bill of Materials. When multiple terminals



are jumpered together, you can have a single catalog item represent a jumper bar that spans the selection, or single jumpers between each terminal.

- **Lookup:** Displays the catalog database from which you can select the Manufacturer and Catalog values.
- **Project:** Lists the part numbers used for similar components in the active project.
- **Copy:** Copies catalog values from the selected jumper in to memory for this session of Auto-CAD Electrical, to b paste into another jumper.
- **Paste:** Paste the previously copied catalog values into the selected jumpers.
- **Clear:** Clear catalog values for the selected jumpers.

## Delete

Select the jumper label, terminal strip, or a single terminal to perform one of the following actions:

- **Jumper label:** Deletes the jumper from all of the terminals.
- **Terminal strip:** Deletes the terminals in that group from the jumper. If there are no remaining terminals in the group, the jumper is deleted.
- **Single terminal:** Deletes the terminal from the jumper. If it is the last terminal deleted, the entire jumper is deleted.

## Select row cell styles

Defines row styles to use in the table style. The selections are stored in the table when it is inserted and the next time the terminal strip is edited, the settings are read back in.

 **Ribbon:** Panel tab ► Terminal Footprints panel ► Editor.





**Toolbar:** Panel Layout

**Menu:** Panel Layout > Terminal Strip Editor

**Command entry:** AETSE

Make your selection on the Terminal Strip Selection dialog box and click Edit. On the Layout Preview tab, select Tabular Terminal Strip (Table Object). Click Row Styles.

**Table Style**

Selects a table style from the active drawing to use. This overrides what is defined in the Terminal Strip Editor dialog box.

**Terminal**

Lists available row cell styles from the selected table style. Select a specific row style to used for terminals, spare terminals, and extra terminals that are inserted due to wiring constraints.

**Accessory**

Lists available row cell styles from the selected table style. Select a specific row style to used for accessories.

## Terminal Strip Table Data Fields to Include

Defines the columns for your tabular terminal report. The selections are stored in the table when it is inserted and the next time the terminal strip is edited, all of the settings are read back in.



**Ribbon:** Panel tab > Terminal Footprints panel > Editor.



**Toolbar:** Panel Layout

**Menu:** Panel Layout > Terminal Strip Editor

**Command entry:** AETSE

Make your selection on the Terminal Strip Selection dialog box and click Edit. On the Layout Preview tab, select Tabular Terminal Strip (Table Object). Click Define Columns.

**Available Fields**

Lists the available fields for formatting the table. Select a field from the list to transfer it into the Fields to Report list.

<b>Fields to Report</b>	Lists the fields to display in the table.
<b>Remove/Remove All</b>	Removes the selected field or all fields from the Fields to Report list.
<b>Move Up</b>	Moves the selected field up one spot in the Fields to Report list.
<b>Move Down</b>	Moves the selected field down one spot in the Fields to Report list.
<b>Cell Style</b>	Specifies the cell style for the table. Within the table styles, you can define different cell styles to use. They give the added flexibility to customize how the terminal strip appears. As you select one of the fields to report you can assign a cell style to the selection.
<b>Name</b>	Displays the name for the field that is selected in the Fields to Report section of the dialog box. Use the default name or enter a new name in the edit box.
<b>Width</b>	Specifies the column width to set for the selected Field to Report. Enter a positive numeric value in the edit box.
<b>Always show jumper circles</b>	Specifies that jumper circles are always shown, and how many, even if a jumper connection is not defined for that terminal. <hr/> <b>NOTE</b> This control is available only when the "Jumper" field is selected. <hr/>
<b>Always show internal jumper squares</b>	Specifies that internal jumper squares are always shown, and how many, even if a jumper connection is not defined for that terminal. <hr/> <b>NOTE</b> This control is available only when the "Jumper-Internal" field is selected. <hr/>

### Available Fields

<b>Installation1</b>	Left Installation column in the Terminal Strip Editor grids.
<b>Location1</b>	Left Location column in the Terminal Strip Editor grids.

<b>Device1</b>	Left Device column in the Terminal Strip Editor grids.
<b>Pin1</b>	Left Pin column in the Terminal Strip Editor grids.
<b>Wire1</b>	Left Wire column in the Terminal Strip Editor grids.
<b>Type1</b>	Left Type column in the Terminal Strip Editor grids.
<b>Cable1</b>	Left Cable column in the Terminal Strip Editor Cable Information grid.
<b>Conductor1</b>	Left Conductor column in the Terminal Strip Editor Cable Information grid.
<b>T1</b>	Left T column in the Terminal Strip Editor grids.
<b>Number</b>	Number column in the Terminal Strip Editor grids.
<b>T2</b>	Right T column in the Terminal Strip Editor grids.
<b>Manufacturer</b>	Manufacturer column in the Terminal Strip Editor Catalog Code Assignment grid.
<b>Catalog</b>	Catalog column in the Terminal Strip Editor Catalog Code Assignment grid.
<b>Conductor2</b>	Right Conductor column in the Terminal Strip Editor Cable Information grid.
<b>Cable2</b>	Right Cable column in the Terminal Strip Editor Cable Information grid.
<b>Type2</b>	Right Type column in the Terminal Strip Editor grids.
<b>Wire2</b>	Right Wire column in the Terminal Strip Editor grids.
<b>Pin2</b>	Right Pin column in the Terminal Strip Editor grids.
<b>Device2</b>	Right Device column in the Terminal Strip Editor grids.
<b>Location2</b>	Right Location column in the Terminal Strip Editor grids.
<b>Installation2</b>	Right Installation column in the Terminal Strip Editor grids.

## Generate terminal strip tables

Use the Terminal Strip Table Generator tool to insert one terminal strip or multiple terminal strips as table objects. There are options to insert a terminal strip as a single table object or to split the terminal strip into multiple table objects. New drawings are created as needed and are automatically added to the active project. This tool can also be used to rebuild or refresh existing terminal strip tables within the active project.

### Insert terminal strip tables onto drawings

- 1 Click Panel tab ► Terminal Footprints panel ► Table Generator.



- 2 Select the terminal strips to create tables from.
- 3 Specify the file name for the first drawing. We recommend that you add a numeric suffix to the file name since the last character of the file name is incremented for each new drawing.
- 4 (Optional) Specify a template file to use.
- 5 Specify the table settings:
  - Specify the table style, row style, table title, and layer.
  - Select Settings to define the X and Y placement values.
  - (Optional) Select Define Columns to define the columns to include, column order, labels and if you want to show jumper circles.
  - (Optional) Select Settings to split the terminal strip into table sections based on rows per section, sections per drawing and specify the section offset values.
- 6 Select whether to insert the tables in new drawings, rebuild an existing terminal strip or refresh an existing terminal strip.
- 7 Click OK.

## Insert a terminal strip table in multiple sections

A terminal strip table can be added through the Terminal Strip Editor or with the Terminal Strip Table Generator tool. A terminal strip can be split into multiple table sections by changing your table settings.

### Terminal Strip Editor



- 1 Click Panel tab ► Terminal Footprints panel ► Editor.
- 2 Make your selection on the Terminal Strip Selection dialog box and click Edit.
- 3 Click the Layout Preview tab.
- 4 Select Settings.
- 5 Enter the number of rows you want for each section. If the table break falls between rows within one terminal definition, the entire terminal definition is placed in the next table section. This results in a table section with fewer rows than defined.

---

**NOTE** If the terminal definition is the first one in the section and exceeds the number of rows per section, the entire terminal definition is kept together in one section.

---

- 6 Specify how many table sections you want to place on each drawing. Unless you insert all the sections on the active drawing, new drawings are created for the table sections.
- 7  Specify the X and Y placement or select the Pick Point button to pick a point on the drawing. This value is used for the first table section on each drawing.
- 8 Specify the distance you want between each section if you are placing more than one section per drawing.
- 9 Specify the direction to place each section after the first table section.
- 10 Specify the offset base point. This option indicates whether you want the distance value measured from insertion point to insertion point, or the gap between the sections.

- 11 Specify the file name for the first drawing. The last character of the file name is incremented for each new drawing.
- 12 (Optional) Specify a template file to use.
- 13 Click OK.

### Terminal Strip Table Generator

- 1 Click Panel tab ► Terminal Footprints panel ► Table Generator.



- 2 Select Settings.
- 3 Enter the number of rows you want for each section. If the table break falls between rows within one terminal definition, the entire terminal definition is placed in the next table section. This results in a table section with fewer rows than defined.

---

**NOTE** If the terminal definition is the first one in the section and exceeds the number of rows per section, the entire terminal definition is kept together in one section.

---

- 4 Specify how many table sections you want to place on each drawing. Unless you insert all the sections on the active drawing, new drawings are created for the table sections.



- 5 Specify the X and Y placement or select the Pick Point button to pick a point on the drawing. This value is used for the first table section on each drawing.
- 6 Specify the distance you want between each section if you are placing more than one section per drawing.
- 7 Specify the direction to place each section after the first table section.
- 8 Specify the offset base point. This option indicates whether you want the distance value measured from insertion point to insertion point or the gap between the sections.
- 9 Specify the file name for the first drawing. The last character of the file name is incremented for each new drawing.

10 (Optional) Specify a template file to use.

11 Click OK.

## Terminal strip table generator

Creates drawing files with tabular terminal strip layouts.

 **Ribbon:** Panel tab ► Terminal Footprints panel ► Table Generator.



 **Toolbar:** Terminal Footprint

 **Menu:** Panel Layout ► Terminal Strip Table Generator

 **Command entry:** AETSEGENERATOR

Terminal Strip Table Generator inserts one terminal strip or multiple terminal strips as table objects. It places all table sections on new drawings, and adds new drawings to the active project.

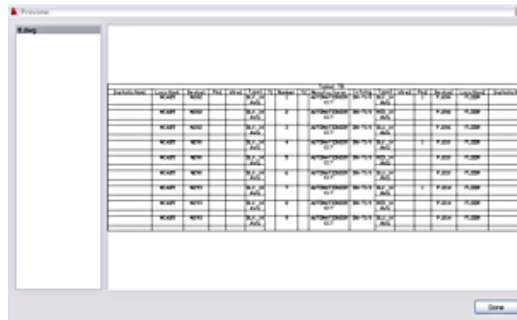

Each terminal strip selected begins on a separate drawing. The installation code, location code, and tag values of the terminal strip are written to the Drawing Description Field inside of the project file (\*.wdp).

### Terminal Strip Selection

Lists all terminal strips in the active project. Select the terminal strips to use for automatically creating the drawing files. You can select a single terminal strip or multiple strips. Multiple strips can be selected using either the Shift or Control keys while highlighting rows, or by clicking and dragging the mouse. Terminal strips are created using an AutoCAD table object.



## Table Settings

<b>Table Style</b>	<p>Specifies the table style to use for the table. Select from the list or click Browse to browse to and select another drawing file whose table styles you want to use.</p> <hr/> <p><b>NOTE</b> If the selected table style is not in the TableStyle.dwg file, it is added.</p> <hr/>
<b>Define Columns</b>	<p>Defines the <a href="#">columns</a> on page 1110 to include, order, headings, justification, and jumper circles display for the jumper chart.</p>
<b>Row Styles</b>	<p>Defines specific row styles to use for the selected table style. On the Select Row Cell Styles dialog box, select the table style and row cell styles to use and click OK.</p>
<b>Layer</b>	<p>Defines the specific layer for the tabular terminal strip to place on when inserted. On the Select Table Layer dialog box, select the layer name from the list of layers on the active drawing and click OK.</p>
<b>Table Title</b>	<p>Defines a title for the table. Enter a title, select from a list of variables or use a combination of both. When selecting from the list, the selection is added to the end of the string if one exists in the edit box.</p>
<b>Total Rows</b>	<p>Displays the total number of rows needed to create the terminal strip table layout. For example, even though the terminal strip contains only 86 terminals, the table format may present more rows in a multi-line terminal situation.</p>
<b>Number of Rows per Section</b>	<p>Displays the number of rows per section as defined on the Table Settings dialog box.</p>
<b>Number of Sections</b>	<p>Displays the number of sections needed based on the total rows and the number of rows per section.</p>
<b>Number of Sections per Drawing</b>	<p>Displays the number of sections to place on each drawing as defined on the Table Settings dialog box.</p>

<b>Number of Drawings</b>	Displays the number of drawings necessary to generate the terminal strip using the current table settings.
<b>Settings</b>	Defines the <a href="#">table settings</a> on page 1093 such as number of rows per section, number of sections per drawing, table, and section placement, section offset, scale, angle, first drawing name if a new drawing is needed, and the template to use for any new drawings generated.
<b>Browse</b>	Browses for any saved settings (in a *.tsl file) that you previously created.
<b>Save As</b>	Saves the settings to an external file (with extension *.tsl) that you can later reuse. The default folder location is the User folder in the Documents and Settings or Users location.
<b>Default</b>	Uses the default settings for creating the table.

### Insert/Rebuild/Refresh

<b>Insert</b>	<p>Creates new drawings for each table or table sections based on the defined table settings and adds the drawings to the active project.</p> <hr/> <p><b>NOTE</b> If the selected strip is found in the project, existing table sections are deleted and new drawings are created and new tables placed.</p> <hr/>
<b>Rebuild</b>	<p>Updates existing tables that were already placed. If the terminal strip exists in the project, table sections are located, deleted, and rebuilt in place without prompting you to select a new insertion point.</p> <hr/> <p><b>NOTE</b> If the selected terminal strip is not found in the project, an alert displays asking if you want to insert the missing strip in a new drawing. If you click Yes, the terminal strip is inserted. If you click No, the terminal strip is not inserted. The terminal strips that were found are updated.</p> <hr/>

## Refresh

Refreshes the data within an existing tabular terminal strip; a new table is not inserted.

---

**NOTE** If the selected terminal strip is not found in the project, an alert displays asking if you want to insert the missing strip in a new drawing. If you click Yes, the terminal strip is inserted. If you click No, the terminal strip is not inserted. The terminal strips that were found are updated.

---

## Terminal strip table settings

Defines the settings for the Terminal Strip table object.

### Terminal Strip Editor

 **Ribbon:** Panel tab ► Terminal Footprints panel ► Editor.

 **Toolbar:** Panel Layout

**Menu:** Panel Layout ► Terminal Strip Editor

**Command entry:** AETSE

Make your selection on the Terminal Strip Selection dialog box and click Edit. Click the Layout Preview tab and select Tabular Terminal Strip (Table Object). Click Settings.

### Terminal Strip Table Generator

 **Ribbon:** Panel tab ► Terminal Footprints panel ► Table Generator.

 **Toolbar:** Terminal Footprint

**Menu:** Panel Layout ► Terminal Strip Table Generator

**Command entry:** AETSEGENERATOR

## Rows Per Section

Specifies how many rows for each table section. If the table break falls between rows within one ter-

terminal definition, the entire terminal definition is placed in the next table section. This results in a table section with fewer rows than defined.

---

**NOTE** If the terminal definition is the first one in the section and exceeds the number of rows per section, the entire terminal definition is kept together in one section.

---

### Sections Per Drawing

Specifies how many table sections to insert on each drawing. All sections are placed on new drawings unless the option “Insert All Sections on Active Drawing” is selected.

---

**NOTE** The “Insert All Sections on Active Drawing” option is not available when using the Terminal Strip Table Generator tool.

---

### Section Placement

Specifies where to place the table in the drawing. You can enter x and y values or pick a point on the screen.

### Section Offset

Specifies the distance between sections, offset direction, and the base point for the distance measurement.

- **Distance:** Specifies the distance between sections.
- **Direction:** Specifies the direction for the offset.
- **Base Point:** Specifies the base point for the distance measurement between sections.

### Scale/Angle on Insert

Specifies the scale and angle of the table sections when inserted. These settings are reflected in the preview.

### Drawing Information for Table Output

- **First Drawing Name:** Specifies a starting drawing file location and file name to use for the automatic creation of the drawing files. The drawings are automatically added to the active project and display at the end of the drawing list in the Project Manager. The last character

of the drawing file name is incremented for each drawing created.

- **Template:** Specifies the template file to use for any new drawings. Enter a template file name or click Browse to search for and select a template file.

#### Show Unused Wire Connections in Table

Select to display all rows for each terminal even if there is no connected component. The Wires per Connection value for the terminal defines the number of rows.

---

**NOTE** A terminal without any connected components has one row in the table.

---

#### Preview

Opens a preview dialog box to view each drawing as it will look when generated. All table settings are reflected in the preview.

## Terminal jumpers

Terminal jumpers can be internal, as defined by the block properties of a multi-level terminal, or an external add-on jumper.

### Internal jumpers

You can define internal jumpers for a multi-level terminal to indicate that certain levels are jumpered together. Define the internal jumpers directly in the terminal [block properties](#) on page 1050. Or, associate an internal jumper definition with a specific catalog in the [Terminal Properties Lookup](#) on page 1058 tables. When the catalog is assigned to a terminal, the internal jumpers are assigned to each terminal in the association.

---

**NOTE** A separate catalog value cannot be assigned to internal jumpers. If the internal jumper is an option for the catalog, we recommend using an [assembly code](#) on page 1295 to link multiple catalog values.

---

### External jumpers

External or add-on jumpers can jumper together any two or more terminals. Use the [Edit Jumper](#) on page 1122 tool to define an external jumper or, define

the jumper from within [Terminal Strip Editor](#) on page 1070. A catalog value can be assigned to an external jumper.

## Edit terminal jumpers

Use the Edit Jumper tool to jumper two or more terminals together in a schematic diagram. The terminals to be jumpered can be on the same drawing or span multiple drawings within the same project. Choose one of the following workflows for editing terminal jumpers:

### Workflow 1:

- 1 Click Schematic tab ► Edit Components panel ►  ► Edit



Jumper.

- 2 Select the primary terminal.
- 3 Do one of the following:
  - Select the secondary terminal on the drawing to create a jumper to the primary terminal. You cannot select a terminal that is part of another jumper.
  - Enter Browse (B) at the command line to browse to and select the secondary terminal in the Select Terminals to Jumper dialog box.
- 4 (Optional) Continue selecting any terminals to add to the jumper.
- 5 Press Enter to create the jumper or enter Edit (E) to edit the jumpers.
- 6 (Optional) If you selected to edit the jumpers, make modifications in the Edit Terminal Jumpers dialog box and click OK.
- 7 (Optional) Enter Show (S) at the command line to draw temporary broken lines between the primary terminal and secondary terminals within the same drawing.

### Workflow 2:

- 1 Click Schematic tab ► Edit Components panel ►  ► Edit



Jumper.

- 2 Press Enter at the command line.
- 3 Select the terminals to be jumpered (from the left tree view) and click the arrow to copy to the right tree view.
- 4 Do one of the following:
  - Click Edit to create the jumper or edit the jumpers on the selected terminal.
  - Click Close to return to the command prompt and:
    - (Optional) Select additional terminals in the drawing to add to the jumper.
    - Press Enter to create the jumper or enter Edit (E) to edit the jumpers.
    - (Optional) If you selected to edit the jumpers, make modifications in the Edit Terminal Jumpers dialog box and click OK.
    - (Optional) Enter Show (S) at the command line to draw temporary broken lines between the primary terminal and secondary terminals within the same drawing.
- 5 Click Cancel to cancel the operation.

### See also:

- [Assign a jumper in Terminal Strip Editor](#) on page 1070

### Select terminals to jumper

Use this to select a terminal from a list of all the terminals in the active project.

 **Ribbon:** Schematic tab > Edit Components panel >  > Edit



Jumper.

 **Menu:** Components > Terminals > Edit Jumper

 **Command entry:** AEJUMPER

Enter Browse (B) at the command line or first select a terminal and then enter Browse (B) to select additional terminals.

As you select a terminal, the drawing in which that terminal resides displays under the tree views or under the terminal preview window.

#### Schematic Terminals

Lists all of the terminal strips and terminals in the active project. Select the terminals to jumper together; as you make your selection, the terminals are bolded in the left tree and added to the Jumper Terminals list.

Terminal nodes have a graphic on the left side to indicate whether the terminal has a jumper attached to it. An empty circle indicates that there is not a jumper and the filled circle means that a jumper exists.

#### Jumper Terminals

Lists the terminals that are jumpered into a single jumper group, including any terminals selected at the command prompt.

< or >

The > button copies the selected terminals to the Jumper Terminals list; the selected terminals are then bolded in the Schematic Terminals list.

The < button removes the selected terminals from the Jumper Terminals list and unbolds the terminal in the Schematic Terminals list.

**Edit**

Creates a jumper across the selected terminals and displays the Edit Terminal Jumpers dialog box.

**View**

Displays the selected terminal in a preview window at the bottom of the dialog box.



---

**NOTE** You can select to view a schematic terminal or tabular view of the entire terminal strip. If you select a terminal strip from the Schematic Terminal list and click View, a tabular view of the terminal strip displays, showing a layout of the connected terminals.

---

By default the preview window is hidden. It can be toggled using Show and Hide once a terminal is viewed.

**Hide/Show**

Switches the visibility of the preview window at the bottom of the dialog box.

**Preview window**

Shows a graphical representation of the selected terminals. You can pan the image using the left mouse button or the Pan tool. You can zoom the image using the mouse wheel or the various zoom tools.

## Edit terminal jumpers

Edits the jumper information (such as adding catalog data) or deletes the jumper.

 **Ribbon:** Schematic tab > Edit Components panel >  > Edit



Jumper.

 **Menu:** Components > Terminals > Edit Jumper

 **Command entry:** AEJUMPER

Enter Edit (E) at the command line or first select a terminal and then enter Edit (E).

**Jumpers to Terminals**

Lists all of the jumpers (grouped by Jumper ID) attached to the selected terminal.

**Catalog Data**

Specifies the catalog data for the jumper between the primary terminal and the selected terminal. If the selected terminal is not jumpered these options are disabled.

- **Manufacturer:** Specifies the manufacturer name.
- **Catalog:** Specifies the catalog number.
- **Assembly:** Specifies the assembly code.
- **Item:** Specifies the item value.
- **Count:** Specifies how the catalog data is used in the Bill of Materials. When multiple terminals are jumpered together, you can have a single catalog item represent a jumper bar that spans the selection, or single jumpers between each terminal.
- **Lookup:** Displays the catalog database from which you can select the Manufacturer and Catalog values.
- **Drawing:** Lists the part numbers used for similar components in the active drawing.
- **Project:** Lists the part numbers used for similar components in the active project.
- **Copy:** Copies catalog values from the selected jumper in to memory for this session of AutoCAD Electrical, to be pasted into another jumper.
- **Paste:** Paste the previously copied catalog values into the selected jumpers.
- **Clear:** Clear catalog values for the selected jumpers.

## Delete

Select the jumper label, terminal strip, or a single terminal to perform one of the following actions:

- **Jumper label:** Deletes the jumper from all of the terminals.
- **Terminal strip:** Deletes the terminals in that group from the jumper. If there are no remaining terminals in the group, the jumper is deleted.
- **Single terminal:** Deletes the terminal from the jumper. If it is the last terminal to delete, the entire jumper is deleted.

<b>View</b>	Displays the selected terminal in a preview window at the bottom of the dialog box. By default the preview window is hidden. It can be switched using Show and Hide once a terminal is viewed.
<b>Hide/Show</b>	Switches the visibility of the preview window at the bottom of the dialog box.
<b>Preview window</b>	Shows a graphical representation of the selected terminals. You can pan the image using the left mouse button or Pan tool. You can zoom the image using the mouse wheel or the various zoom tools.

## Terminal strip utilities

### Create terminal strips

Use the terminal strip utilities to create non-intelligent terminal strips. The terminal numbers can be imported from a file, windowed on one or more drawings, individually picked, or typed in by hand.

- 1 Select to pick or window the text and/or attribute values you want to import into the terminal strip generator utility -  
Enter AETERMLIST at the command prompt.  
or select the file containing the terminal text -  
Enter AETERMLISTFROMFILE at the command prompt.
- 2 In the Terminal Strip Representation dialog box, sort, add, remove, and rearrange the terminal strip layout.
- 3 Click OK.  
The Terminal Strip Representation Setup dialog box displays. Set the text size, terminal height and width sizes, and terminal strip orientation.
- 4 Make your selections and click OK.
- 5 Select the insertion point for your terminal strip.

### Modify an existing terminal strip

- 1 Re-invoke the command, window the existing terminal strip to capture the existing terminal numbers.
- 2 Cancel the command.
- 3 Delete the old terminal strip.
- 4 Re-invoke the terminal strip utility.
- 5 Make any edits and re-insert the terminal strip.

## Terminal strip representation

### Terminal List (Manual Picks)

 **Menu:** Components ► Terminals ► Terminal Strip Utilities ► Terminal List (Manual Picks)

 **Command entry:** AETERMLIST

### Terminal List (From File).

 **Menu:** Components ► Terminals ► Terminal Strip Utilities ► Terminal List (From File)

 **Command entry:** AETERMLISTFROMFILE

You can sort, add, remove, and re-arrange the terminal strip layout. You can even go to other schematic drawings and add more to the list (just click Cancel, go to the next drawing, and re-invoke the utility - it remembers what you have accumulated so far).

Define spare	Defines the label for the spare terminals.
Sort	Sorts the list of terminals in ascending order.
Reverse sort	Rearranges the list of terminals in descending order.
Move up	Moves the selected terminal up one spot in the terminal list.
Move down	Moves the selected terminal down one spot in the terminal list.
Insert new	Creates a terminal to add to the terminal strip. Specify the terminal name/number, the number of terminals to insert, and indicate whether to make the new terminal the spare terminal.

<b>Edit</b>	Opens the Edit dialog box so you can change the terminal text or count.
<b>Cut</b>	Removes the selected terminal from the terminal list.
<b>Copy</b>	Makes a copy of the selected terminal and stores it in the Paste clipboard.
<b>Paste</b>	Adds the copied terminal into the terminal list from the clipboard.
<b>Pick</b>	Temporarily dismisses the dialog box and allows you to select more terminals for the list.

## Terminal strip representation - setup

Annotates the text size, height and width sizes, and orientation of the terminal strip.

### Terminal List (Manual Picks)

 **Menu:** Components ► Terminals ► Terminal Strip Utilities ► Terminal List (Manual Picks)

 **Command entry:** AETERMLIST

Select the terminal to modify and click OK.

### Terminal List (From File).

 **Menu:** Components ► Terminals ► Terminal Strip Utilities ► Terminal List (From File)

 **Command entry:** AETERMLISTFROMFILE

Select the terminal to modify and click OK.

### Terminal Text

<b>Text</b>	Specifies to align the text to the left, center, or right side of the terminal strip.
<b>Height</b>	Sets the height of the terminal strip.
<b>Width</b>	Sets the width of the terminal strip.
<b>Layer</b>	Specifies the layer for the table text. The selected layer is displayed next to the button on the dialog box.

### Terminal pitch and Terminal width

<b>Terminal pitch (spacing)</b>	Sets the spacing between entries in the terminal strip.
<b>Terminal width</b>	Sets the width for the terminal strip.
<b>Use .750</b>	Changes the terminal width value to .750 if selected.

### Terminal Ruling

<b>Box Around</b>	Creates a single box around the terminal strip.
<b>Between Entries</b>	Creates lines between entries in the terminal strip.
<b>Start Line</b>	Specifies which line the terminal strip starts at.
<b>End</b>	Specifies which line the terminal strip ends at.
<b>Layer</b>	Specifies the layer for the table ruling lines. The selected layer is displayed next to the button on the dialog box.

### Terminal Strip Orientation

<b>Vertical</b>	Specifies to display the terminal strip vertically.
<b>Rotate 90 degrees (counter-clockwise)</b>	Specifies to rotate the terminal strip 90 degrees in a counter-clockwise direction.
<b>Rotate -90 degrees (clockwise)</b>	Specifies to rotate the terminal strip 90 degrees in a clockwise direction.

## Terminal wire connections

### Control terminal wire connections

Schematic and panel layout/wiring diagram terminal symbols can carry TERMDESC attribute values used to control which side of a terminal is to receive internal or external wire connections. Schematic terminals use attributes X1TERMDESC01 for the right wire connection, X2TERMDESC01 for the top, X4TERMDESC01 for the left, and X8TERMDESC01 for bottom wire connections.

### Show terminal internal/external connections

This tool shows the state of the invisible attribute values for selected objects. The values are shown with red and green arrows.

- 1 Click Schematic tab ➤ Edit Components panel ➤  ➤ Terminal:

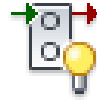

Show Internal/External Connections.

- 2 Select the objects to show the connection codes for. You can pick on individual objects or select a group of objects using a boundary box.

### Mark internal connections

This tool marks attributes with an 'I' for internal wiring.

- 1 Click Schematic tab ➤ Edit Components panel ➤  ➤ Terminal:



Mark Internal Connections.

- 2 Select near a wire connection point of the terminal. The attribute is marked with an arrow to indicate whether it is an internal.

### Mark external connections

This tool marks attributes with an 'E' for external wiring.

- 1 Click Schematic tab ➤ Edit Components panel ➤  ➤ Terminal:



Mark External Connections.

- 2 Select near the wire connection point of a terminal. The attribute is marked with an arrow to indicate whether it is an external value.

### Erase connection codes

- 1 Click Schematic tab ➤ Edit Components panel ➤  ➤ Terminal:



Erase Internal/External Connections.

- 2 Select near the wire connection point of a terminal to erase the connection code. (I= internal, E= external)

## Resequence terminal numbers

### Resequence terminal numbers

AutoCAD Electrical provides utilities to make it easy to resequence the terminal numbers across one or many drawings. These utilities do not resequence terminals that carry a wire number as the terminal number.

#### Terminal Renumber (Pick Mode)

- 1 Enter AETERMRENUMPICK at the command prompt.
- 2 Enter the first terminal number to use and press Enter.
- 3 Select each terminal in order on the screen.  
The terminal number updates automatically, incrementing with each pick.
- 4 Right-click to exit the command.

#### Terminal Renumber (Project-Wide)

- 1 Enter AETERMRENUM at the command prompt.  
The Project-wide Schematic Terminal Resequence dialog box displays.
- 2 Enter the terminal strip tag ID and the starting terminal number.
- 3 If you want to refine the search, enter an installation or location code to use when searching the drawings.  
Click Project or Drawing to select an installation or location code from existing terminal numbers.
- 4 Click OK.



- 5 In the Select Drawings to Process dialog box, select the drawings to search through, and click OK.

---

**NOTE** These tools do not renumber panel terminals. Use the Terminal Strip editor [Renumber](#) on page 1101 to resequence a terminal strip that contains panel terminals.

---

## Project-wide schematic terminal renumber

Resequences the terminal numbers across one or many drawings.

 **Menu:** Components ► Terminals ► Terminal Strip Utilities ► Terminal Renumber (Project-Wide)

 **Command entry:** AETERMRENUM

---

**NOTE** This tool does not resequence terminals that carry a wire number as the terminal number.

---

<b>Tag-ID</b>	Specifies the terminal strip ID to use when searching each drawing for terminals. Only terminals with this ID are updated.
<b>Include Installation/Location in terminal strip Tag-ID match</b>	Updates a terminal only if it matches the Terminal Strip ID, Location, and Installation values specified.
<b>Installation code</b>	Refines the search by including an installation value.
<b>Location code</b>	Refines the search by including a location value.
<b>Starting terminal number</b>	Specifies the number to begin the terminal strip with; you can use alphanumeric values. The default value is 1.

After you click OK, select the drawings to process from the active project.

---

**NOTE** This tool does not renumber panel terminals. Use the Terminal Strip editor [Renumber](#) on page 1101 to resequence a terminal strip that contains panel terminals.

---

## Overview of connection sequencing

The Multi-Connection Sequence Terminal symbol allows a single in-line schematic symbol to represent a sequence of wire connections passing through two or more (up to six) terminal strips. For example, a wire connection that

must pass through a series of shipping split terminal strips can be represented by a single in-line wire schematic symbol (instead of having to show each individual terminal in the sequence).

Two sample symbols are provided. Their appearance may be edited or new ones created as required. They are inserted using the AutoCAD Electrical Insert Component tool. Browse to insert. The symbol names are

H - - 1\_MULTI\_CONN.dwg wire number changes through the symbol

H - - 1\_MULTI\_CONN\_NOCHG.dwg wire number does not change through it

A dialog box interface lets you encode multiple connection sequence information on to six sets of attribute groups carried on the symbol:

WD\_1\_TAGSTRIP Attribute to carry first terminal strip number (16 character maximum)

WD\_1\_TERMNO Attribute to carry optional terminal number

WD\_1\_INFO Attribute to carry additional information such as installation, location, catalog and item number assignments, and any connected cable information

WD\_2\_TAGSTRIP Same as previous but for second terminal in the sequence

WD\_2\_TERMNO Same as previous but for second terminal in the sequence

WD\_2\_INFO Same as previous but for second terminal in the sequence through maximum of

WD\_6\_TAGSTRIP Same as previous but for sixth terminal in the sequence

WD\_6\_TERMNO Same as previous but for sixth terminal in the sequence

WD\_6\_INFO Same as previous but for sixth terminal in the sequence

Click the entry to edit and select the Edit button.

---

**NOTE** For AutoCAD Electrical to recognize this symbol as a multi-connection sequence terminal symbol, at a minimum it must carry attribute named WD\_1\_TAGSTRIP. Multi-connection sequence terminal symbols do not support some AutoCAD Electrical auto-update and surfing features.

---

## **Edit multi-connection sequence terminal symbol**

 **Ribbon:** Schematic tab ► Insert Components panel ► Insert Components

drop-down ► Icon Menu.



 **Toolbar:** Main Electrical

 **Menu:** Components ► Insert Component

 **Command entry:** AECOMPONENT

Enter "H--1\_MULTI\_CONN\_NOCHG" in the Type It box and click OK. Specify the insertion point on the drawing.

Select any entry within a group to view/edit that group.

**Edit** Opens the Edit entry dialog box so you can change values such as the tag-ID, terminal number, or installation code.

**Save Changes** Saves your changes by writing the data to attributes on the symbol (most of these attributes are set as invisible).

## Edit entry

 **Ribbon:** Schematic tab ► Insert Components panel ► Insert Components

drop-down ► Icon Menu.

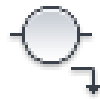

 **Toolbar:** Main Electrical

 **Menu:** Components ► Insert Component

 **Command entry:** AECOMPONENT

Enter "H--1\_MULTI\_CONN\_NOCHG" in the Type It box and click OK. Specify the insertion point on the drawing. In the Edit Multi-Connection Sequence Terminal Symbol dialog box, select one of the six series-connected entries and click Edit.

This in-line component lets you manually define a connection sequence of up to six series-connected terminal strip points. All are embedded in this single graphical component but are fully reported in the various wire connection reports.

For example, you might have a wire that connects from a push button and goes out to a field device. But to get to the field device, the wire connection must pass through a local terminal strip, then a shipping split terminal strip, on to a field connection terminal strip, and finally a terminal strip near the field device. Instead of showing all four series-connected terminals in the wire, you can substitute this single "multi-connection sequence" terminal representation and manually define the connection sequence.

### **Tag - ID**

Terminal strip tag-ID

### **Terminal Number**

Terminal strip terminal number

### **Miscellaneous**

Edit box shows saved data values defined by the following selections.

### **Installation Code**

Changes the installation code assignment. You can search the current drawing or entire project for installation codes. A quick read of all the current or selected drawing file is done and a list of installation codes used so far is returned. Select from the list to update the component automatically with the installation code.

Assign short installation codes to components like "PNL" and "FIELD" so you can create location-specific BOM and component lists later.

### **Location Code**

Changes the location codes. You can search the current drawing or entire project for location codes. A quick read of all the current or selected drawing file is done and a list of location codes used so far is returned. Select from the list to update the component automatically with the location code.

Assign short location codes to components like "PNL" and "FIELD" so you can extract cable from/to reports and location-specific BOM reports later. (For example, BOM for all field cables, BOM for all PNL cables.)

### **Catalog Data**

You can do a drawing-wide or project-wide listing of similar components with their catalog assignments. During your editing session, the last MFG / CAT / ASSYCODE assignment for each component type you insert into your wiring

diagram is remembered. When you insert another component of that type, the previous catalog assignment of the component is set as the default (assuming a previous one was made during the current editing session).

<b>Find</b>	Scans each drawing for the target component type and returns a list of what was found. You can make your catalog assignment by selecting from the list.
<b>Catalog Lookup</b>	Opens the catalog database of the catalog from which you can manually enter or select the Manufacturer or Catalog values. Search the database for a specific catalog item to assign to the selected component.
<b>Drawing</b>	Lists the part numbers used for similar components in the current drawing.
<b>Project</b>	<p>Lists the part numbers used for similar components in the project. You can search in the active project, another project, or in an external file.</p> <ul style="list-style-type: none"><li>■ <b>Active project:</b> All the drawings in the current project are scanned and the results are listed in a dialog box. Select from the list to assign your new component with a catalog number that is consistent with other similar components in the project.</li><li>■ <b>Other project:</b> Scans each listed drawing in a previous project for the target component type and returns the catalog information in a sub-dialog box. Make your catalog assignment by picking from the list.</li><li>■ <b>External file:</b> You can pull catalog assignments from a generic ASCII file created by a word processor or output from a spreadsheet or database program. A dialog box displays the contents of the selected text file. Find and highlight the desired entry. AutoCAD Electrical reads the line of text from the file and breaks it into its component parts. These are displayed in the left-hand list. For each relevant item, highlight it and then pick the appropriate category button in the center column. The highlighted item is transferred to the corresponding category (and then to the Insert/Edit dialog box once OK is clicked).</li></ul>
<b>Catalog Check</b>	Displays what the selected item looks like in a Bill of Material template.

### Wire entering this connection

Click Internal, External, or Both to change the Connection Code (I=Internal, E=External). The code changes the Miscellaneous value as follows: LEFT\_TERMDESC=I (for Internal), LEFT\_TERMDESC=E (for External).

### Wire leaving this connection

Click Internal, External, or Both to change the Connection Code (I=Internal, E=External). The code changes the Miscellaneous value as follows: RIGHT\_TERMDESC=I (for Internal), RIGHT\_TERMDESC=E (for External).

<b>Wire number</b>	Manually define the wire number that leaves this terminal connection and goes to the next. If it is the last terminal in the sequence, this wire number assignment is ignored and the actual wire number connecting the right-hand side of the symbol is used.
<b>Wire layer</b>	Manually define the wire layer assignment. If it is the last terminal in the sequence, this value is ignored.
<b>Cable</b>	Manually define the cable marker tag-ID. If it is the last terminal in the sequence, this value is ignored.
<b>Conductor</b>	Manually define a cable marker conductor color value. If it is the last terminal in the sequence, this value is ignored.

### Delete this entry

Removes the displayed terminal sequence from the overall list and moves any following entry positions up to fill in the gap.

### Insert new before this one

Moves the current display terminal sequence down one position and creates a new, empty entry ahead of it. There is a maximum of six total positions.

### Insert new after this one

Pushes all of the following sequences down one position and creates a new, empty entry just after the displayed entry. There is a maximum of six total positions.

# Point-to-Point Wiring Tools

# 14

## Working with Connectors

### Use point-to-point wiring tools

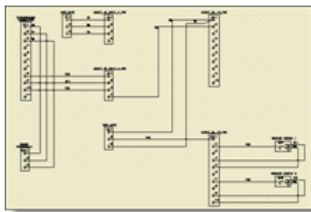

Point-to-Point Style Schematic

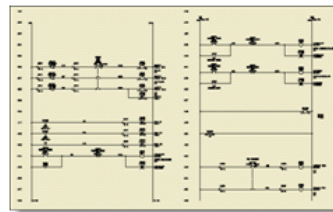

Ladder Style Schematic

In addition to the tools specifically related to connectors, you can utilize other AutoCAD Electrical tools for editing your point-to-point wiring diagrams.

#### Edit Pin Numbers

Use the Edit Component tool to edit the pin assignments on the parametrically generated connectors.

#### Connector Dash Link Lines

Use the Link Components (Dashed Line) tool to insert dash linked lines between parent and split-off child parametric connector symbols.

#### Scout Connector

Use the Scout tool to reposition the parametric connector along the same direction as the connected wiring.

### Scoot Wire

Use the Scoot tool to move wires attached to pins on the connectors. The wire scoots and the connector pin along with it while the overall connector shell stays fixed.

### Insert Wires

Use the Insert Wires tool to route single-wire connections. Use the Multiple Wire Bus tool, Component mode, to insert and route multiple wires in one tool.

---

**NOTE** A wire connection point should only have up to three wire connections tied to it. Adding more wires to a single point prevents the angled wire connection to tie uniquely to the wire connection point.

---

## Insert connectors

Use this tool to insert a parametrically generated connector symbols.

- 1 Click Schematic tab ► Insert Components panel ► Insert Connector

drop-down ► Insert Connector. 

- 2 In the Insert connector dialog box, specify the pin spacing and pin count. (Optional) For pin count, click Pick and draw a fence showing the length of the appropriate connector.
- 3 Specify whether to build the connector using fixed pin spacing or to have it compress or expand to match the pins up with underlying wire crossings.
- 4 Specify whether to insert the entire connector all at once or to insert it manually, pin by pin, with an option to insert spacers or to break the connector into 2 or more pieces.
- 5 Click the Rotate or Flip buttons to change the display of the connector symbol.  
The preview image updates to reflect your changes to the connector display options.
- 6 (Optional) Click Details for more options to define settings for the size, shape, and display of the parametrically built connector symbols.
- 7 Click Insert.



A preview outline of the connector displays for placement on the drawing. It shows rounded corners for the plug side of the connector. An 'x' indicates the insertion point of the connector and the arrow indicates the plug side wire connection direction.

- Specify the insertion point on the drawing or enter Z (zoom), P (pan), X, V, or Tab at the command prompt to change the connector orientation before insertion. Review the sections below to see how Tab, V key, or X key changes your connector orientation.

If you selected to allow spacers/breaks, in the Custom Pin Spaces/Breaks dialog box, click Break Symbol Now to break the connector and display the Connector Layout dialog box for defining how you want the rest of the pins inserted on the drawing.

### Reverse connector using the Tab key

Prior to committing the connector outline to the drawing, you can press Tab to reverse the connector either about its long axis or end for end. If the connector is vertical, a series of TAB keystrokes cycles the image through these four orientations:

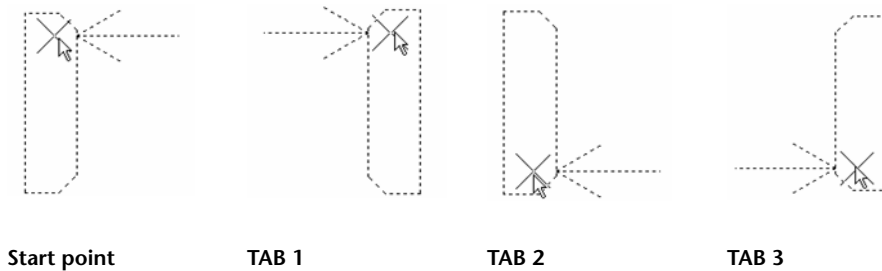

### Rotate connector using the V key

Press "V" at the command prompt to switch between vertical and horizontal orientations. Based on where the outline is in the flip process, the Tab keystroke reverses the connector either about its long axis or end for end. When in its

horizontal orientation, a series of Tabs cycles the image through these four orientations

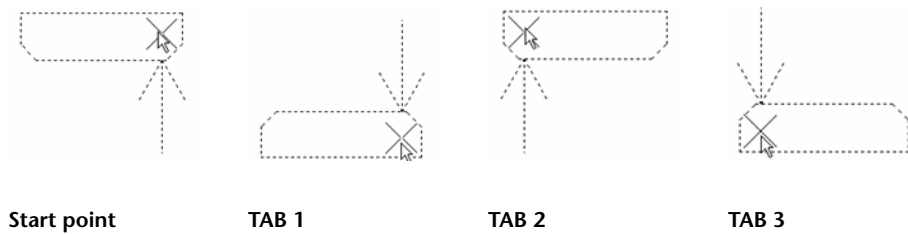

### Switch layout using the X key

Press "X" at the command prompt to toggle between "Fixed Spacing" and "At Wire Crossings." Press the X key, and then move the connector preview over the wires so the connector stretches to align each pin with the underlying wire spacing. The connector stretches only to meet the underlying spacing when the first pin lands on a wire. If the size of the connector exceeds the total number of wires underlying the connector, the remaining pins follow the specified fixed spacing value.

### Rotate connectors

Rotates a connector image in 90 degree increments.

Existing wire connections do not reroute with each rotation of the connector. Use the wire editing tools to resolve wiring.

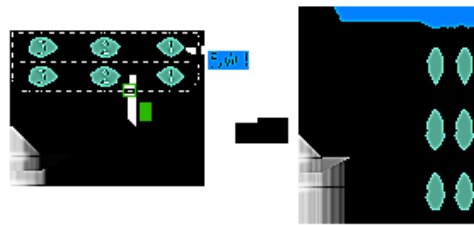

---

**NOTE** This command differs from the standard ROTATE command in that it renames the wire connection attributes to maintain full compatibility with the Insert Wire command, and it can hold the terminal pin text and tag-ID attributes in their current orientation.

---

- 1 Click Schematic tab ► Edit Components panel ► Modify Connectors



drop-down ► Rotate Connector.

- 2 Specify whether to hold the current attribute orientation.  
If you select Yes (default), the attribute text orientation does not rotate as the connector rotates.
- 3 Select the connector to rotate.  
The connector automatically rotates 90 degrees.
- 4 Keep clicking the connector until the appropriate position is reached.
- 5 Press Enter or Esc to exit the command.

#### Example: Hold attribute orientation = yes

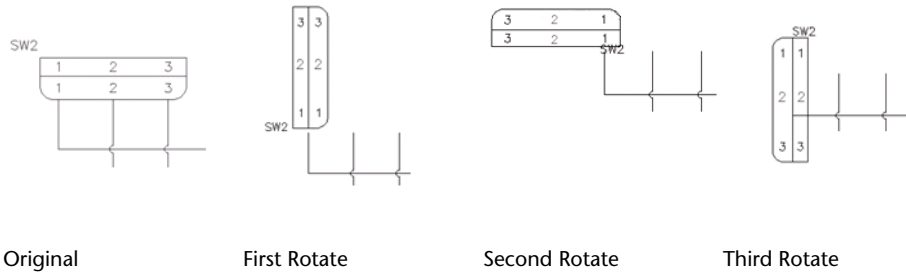

#### Example: Hold attribute orientation = no

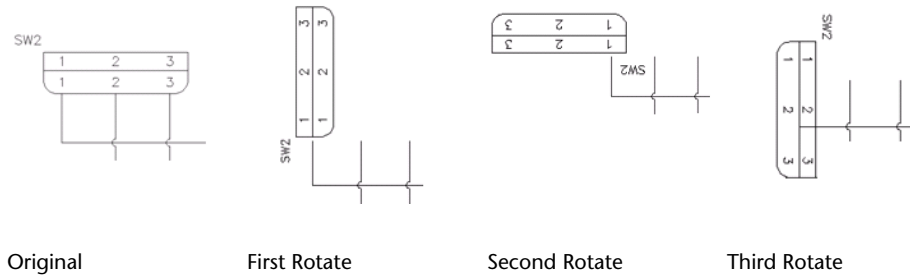

#### Reverse connectors

Reverses the connector image about its long axis.

Existing wire connections do not automatically reroute to the reverse side of the connector. Use the wire editing tools to resolve wiring.

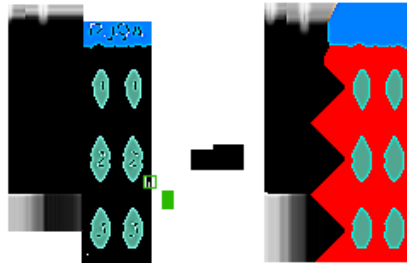

- 1 Click Schematic tab ► Edit Components panel ► Modify Connectors



drop-down ► Reverse Connector.

- 2 Select the connector to reverse.

The connector automatically reverses depending on its original orientation.

---

**NOTE** For a single receptacle connector with no rounded corners, the appearance of the graphics appears unchanged, but the wire connection attributes actually move to the other side of the connector.

---

- 3 Press Enter or Esc to exit the command.

## Stretch connectors

You can increase or decrease the overall shell length of the connector. Identify which end of the connector to alter and the measurement of displacement.

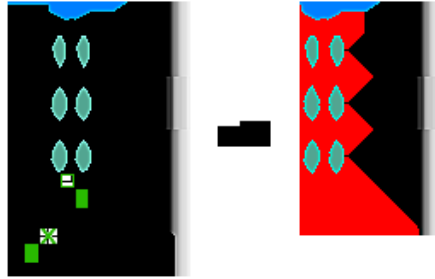

- 1 Click Schematic tab ► Edit Components panel ► Modify Connectors



drop-down ► Stretch Connector.

- 2 Specify the end of the connector to stretch.
- 3 Specify where you want the connector to end (second point of displacement). Either drag your mouse to the appropriate location or enter coordinates.

---

**NOTE** You can press TAB during the stretch to change the visibility of the connector attributes. See the Tips and Hints below for more information.

---

- 4 Press Enter or Esc to exit the command.

### Tips and Hints

- Stretch Connector does not support window selection.
- Turn Snap ON.
- The stretch begins at the end of the connector. There is not a first point of displacement.
- If the stretched connector end runs over the top of the connector's tag-ID attribute (attribute name TAG1 or TAG2), then this attribute along with attributes INST, LOC, DESC1, DESC2, and DESC3 relocate with the stretch. Pressing TAB during the stretch changes the visibility of these attributes. If turned ON, the attributes display as temporary graphics that move with the stretch cursor; if turned OFF, the temporary graphics are not visible.

- Avoid stretching one end of a connector all the way to the other end of the connector.

## Split connector

Use this tool to split the parametric connector into two separate block definitions (for example, parent and a child or a child and another child).

You specify:

- Origin point for the new block
- Break type
- Layer for the child block
- Whether to reposition the child block

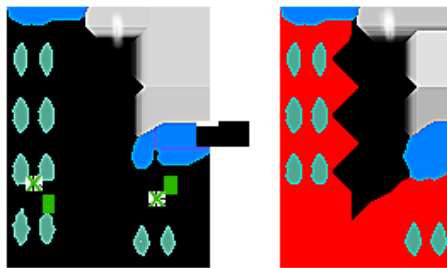

- 1 Click Schematic tab ► Edit Components panel ► Modify Connectors

drop-down ► Split Connector. 

- 2 Select the connector block to split.
- 3 Specify the split point (i.e. pick between two sets of pins).
- 4 (Optional) Define the origin point for the new block. The default is preset to be in-line with the first set of pins on the split-off piece. If you do not want to accept the default, you can enter the coordinates or click Pick Point, and then select the origin point on the drawing.
- 5 (Optional) Set the break type: no lines, straight lines, jagged lines, or draw it. The default is set to jagged lines.

- 6 (Optional) Select to reposition the child block to move it as part of this command.
- 7 Click OK.
- 8 To reposition the child block, select a point on the screen to place the block.
- 9 Press Enter or Esc to exit the command.

### Add pins to a connector

Adds connector pins to an existing connector.

To make room for the new pins:

- Stretch Connector - stretch the connector shell
- Move Connector Pin - move existing pins
- Scoot - scoot wires with attached pins

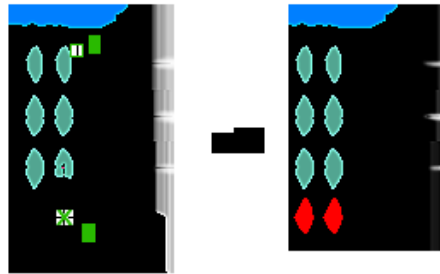

- 1 Click Schematic tab ► Edit Components panel ► Modify Connectors

drop-down ► Add Connector Pins. 

- 2 Select the connector.
- 3 Specify where to insert the next available pin number (displayed on the command line) or press R+space to manually define the new starting pin number.

The next available pin numbering is based on the existing pins and an optional pin list associated to the selected connector. The PINLIST values

defined on the parent symbol are queried in the project database to determine the next available pin number on the connector component. This checks across the entire project to find the pin numbers used on both parent and any child connector symbols. If a PINLIST value is not defined, then the next available sequential pin number (based on existing pins) is used. Pin assignments can be numbers or letters or combinations of both.

- 4 Press Enter or Esc to exit the command.

### **Tips and Hints**

- Turn Snap ON.
- Pins can be added inside the shell or beyond either end of the connector shell.
- Pins are inserted along the connector's centerline axis, even if your pick point is far off to one side of the connector.
- Connectors can be stretched later to accommodate new pins added beyond either end of the connector.
- Pins can be added between the original pins; pins can then be moved or scooted to accommodate spacing.
- Pins can be lined up with a pin on another connector. After selecting the Add Connector Pins tool, select the connector to add the pin to, press Shift + right-click to display the Object Snaps options, select Insert and click the pin to align the new pin to. The new pin is inserted onto the selected component and is lined up with the pin on the other connector.

### **Delete pins from connectors**

Deletes connector pins from an existing connector.

If the connector has a defined pin list, free this deleted pin for later insertion on this connector or on a related child of this connector.



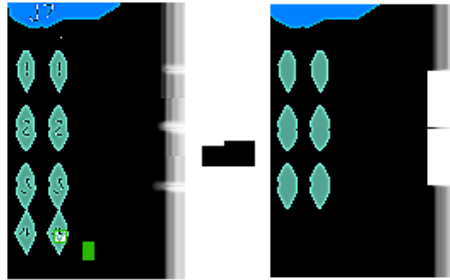

- 1 Click Schematic tab ► Edit Components panel ► Modify Connectors

drop-down ► Delete Connector Pins.



- 2 Pick the pins to delete from the connectors.

The pin number attribute on the connector block disappears. This attribute along with associated wire connection and description attributes are not immediately removed from the connector. They are renamed so that they are effectively ignored. If the connector is subsequently stretched or split, then these deleted pin attributes are purged from the connector block instance.

- 3 Press Enter or Esc to exit the command.

### Tips and Hints

- Deleting a pin that has a connected wire does not remove the wire. In this case, the wire no longer is connected to the connector. It appears to be a wire that is unconnected at the connector end.

### Swap pin numbers

Swaps pin numbers on existing connectors.

Exchange one set of connector pin numbers for another on an existing connector or between connectors on the drawing.

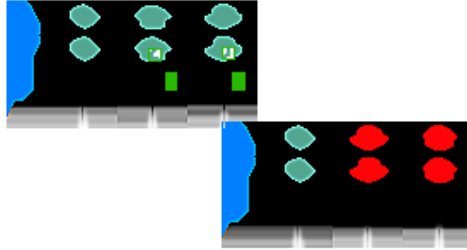

---

**NOTE** You cannot swap a combination connector with a single plug or receptacle connector. Additionally, you cannot use this tool to swap pins from one side of a connector to the other.

---

- 1 Click Schematic tab ► Edit Components panel ► Modify Connectors

drop-down ► Swap Connector Pins.



- 2 Select the connector pin to swap.  
Temporary graphics are drawn around the selected pin number indicating that it has been included in the "swap" list.
- 3 Select the pin that you want to swap with the selected pin.  
The connector pins are swapped between the two selections.
- 4 Select another set of pins to swap or press Enter or Esc to exit the command.

## Move pins

Moves the connector pin associated to a selected connector.

The pin relocates along the centerline axis of the connector, even if the pick point is off to one side of the connector. You can specify a location beyond either end of the current connector shell. Use Stretch Connector to extend the shell to enclose these pins.

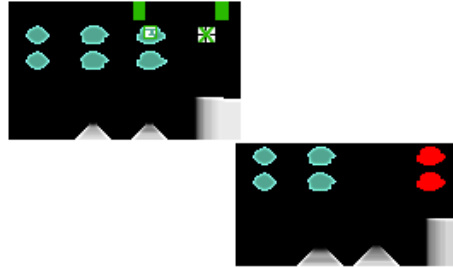

- 1 Click Schematic tab ► Edit Components panel ► Modify Connectors

drop-down ► Move Connector Pins.



- 2 Select the connector pin to move.
- 3 Specify the new location for the pin.

The pin relocates along the connector's centerline axis, even if your pick point is far off to one side of the connector. You can also specify a location beyond either end of the current connector shell, and then use the Stretch Connector tool to extend the shell to enclose these pins.

- 4 Press Enter or Esc to exit the command.

## Edit connector pin numbers

Once the connector is inserted onto the drawing file's block definition, you can edit the connector pins found inside of the connector. Use the Connector Pin Numbers in Use dialog box to edit the pins defined on the parametric connector. Connector symbols have attributes to define Installation and Location codes, manufacturing data, component tagging and descriptions, and pin assignments.

- 1 Click Schematic tab ► Edit Components panel ► Edit Components

drop-down ► Edit.



- 2 Select the connector.
- 3 In the Insert/Edit Component dialog box, Pins section, click List.



- 4 In the Connector Pin Numbers in Use dialog box, select a pair of pins to modify.
- 5 In the Pin Number section, enter a new pin number value in the edit boxes or click the arrows to either increase or decrease both plug and receptacle values by one.
- 6 (Optional) Enter a description for the plug or receptacle terminal.
- 7 Click OK.

## Insert connector

Generates a connector dynamically from parameters you specify, and inserts it at a specified location.

 **Ribbon:** Schematic tab ► Insert Components panel ► Insert Connector

drop-down ► Insert Connector. 

 **Toolbar:** Main Electrical 

 **Menu:** Components ► Insert Connector ► Insert Connector

 **Command entry:** AECONNECTOR

You select an orientation, connector type, such as plug/receptacle combination, and enter fixed pin spacing or adapt the pin spacing to underlying wires, and so on. Insert Connector negates the need to create and maintain a large library of schematic connector symbols.

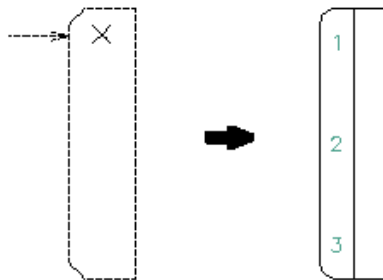

Click Details to expand the dialog box to provide more options to define settings for the size, shape, and display of the parametrically built connector symbols.

### **Layout**

Determines the overall appearance of the parametric connector, including pin spacing and pin count.

<b>Pin Spacing</b>	Specifies the distance between the pin wire connections. This value initially defaults to the Rung Spacing defined in Drawing Properties ► Drawing Format ► Ladder Defaults - Spacing setting for the drawing file.
<b>Pin Count</b>	Specifies the number of pins associated with the connector. This is required to parametrically build the connector.
<b>Pick</b>	This is an alternate Pick method for determining the Pin Count for the new connector. You can do a fence selection of crossed wires or you can define a starting point and ending point in empty space. For the fence selection, a pin exists for every wire intersection with the AutoCAD fence line. For example, if you cross five wires with the fence pick points, the pin count value will be 5. On the other hand, if you select endpoints in empty space, the total number of pins is based upon dividing the distance between the two pick points by the Pin Spacing value.
<b>Fixed Spacing</b>	Generates the connector with a fixed spacing from one pin to the next. This is the Pin Spacing value. If the Pin Spacing edit box is left blank, the fixed spacing value defaults to the drawing's ladder default spacing value.
<b>At Wire Crossings</b>	Modifies the pin placement to have the pins coincide with underlying wires. The connector stretches or compresses to match up with underlying wires as it inserts on to the drawing. If the connector has more pins than underlying wires, the excess pins are added at the end of the connector using the default fixed spacing value.
<b>Pin List</b>	Specifies either the starting pin number for an incrementing series of pin numbers or the actual comma-delimited list of pin numbers to be used on the connector. For example,

a pin list entry of "1" for a connector with the Pin Count set to 8 generates a connector with pins labeled "1" through "8." On the other hand, a pin list entry of "1,2,3,4,A,B,C,GND" generates an 8-pin connector with pins labeled "1", "2", "3", "4", "A", "B", "C", "GND." If the Pin List edit box is left blank, the connector numbering starts at 1 and continues up through the Pin Count value. If you define more pin list data than pin count, the pins are used in the order they are defined. The entire list is saved on the connector as PINLIST xdata. This can be later referenced to add missing pins (Add Connector Pin tool) or to assign unused pins to a child instance of the parent connector.

#### **Insert All**

Creates the connector without further prompts (i.e. no option for inserting spacers or for breaking the connector into 2 or more pieces).

#### **Allow Spacers/Breaks**

Gives you manual control over the insertion of the connector. Displays the Custom Pin Spaces/Breaks dialog box that prompts you for the insertion of each connector pin prior to committing the connector block definition to the drawing file. The running count of pins inserted versus total pins defined for the connector is listed at the top of the dialog box. Select an option for inserting the other pins:

- **Insert Next Connection:** Continues building the connector by inserting the next pin (repeated prompting until all pins are inserted).
- **Add Spacer:** Adds a spacer in place of a pin on the connector in order to leave room for a future pin or to skip over a wire that is not to be broken by the connector. The connector stretches its length to account for this extra blank space.
- **Break Symbol Now:** Breaks connector and begins prompt back at the connector layout dialog box. If you terminate the command without inserting the remainder of the connector, you can go to another drawing and restart the command. You can continue with the previous connector or discard the saved data and start with a new one.

---

**NOTE** This insert of a continued, broken connector must be done during the current AutoCAD Electrical session.

---

- **Cancel Custom:** Inserts the remaining pins into the connector without any further prompts.

#### **Start Connector As Child**

Defines the new connector block definition as a child of a parent connector. This means that after it is created it needs to be linked to a parent connector through a common tag-ID value (select Edit Component and link to parent using any of the normal methods).

#### **Start with Break**

Creates the child symbol with a jagged or broken top. If unselected, the child symbol has a rounded corner determined by the radius dimension defined in the Size section of the dialog box.

### **Orientation**

Use to quickly change the connector's orientation prior to placing it into the drawing file. This orientation change also modifies the preview to reflect the selection.



#### **Rotate**

Switches the orientation of the parametric connector insertion between horizontal and vertical.



#### **Flip**

Flips the connector about its long axis.

### **Type**

Determines the type of connector to be built as to whether it includes the plug/receptacle combination or if it will display either the plug side or the receptacle side.

#### **Plug/Receptacle Combination**

Creates the connector as a single block file showing both the plug and receptacle.

<b>Wire Number Change</b>	Sets the property of the connector symbol to change the wire number through a plug/receptacle connector symbol. By default, the wire numbers are maintained through a plug/receptacle connector.
<b>Add Divider Line</b>	Creates a plug/receptacle combination connector with a line down the middle of the block to indicate the separation of the plug and receptacle. This line becomes part of the block definition for the connector.
<b>Plug Only</b>	Creates the connector as a single block file showing the plug representation only.
<b>Receptacle Only</b>	Creates the connector as a single block file showing the receptacle representation only.

### **Display**

Use to define the connector's placement on the drawing relative to other connectors and the drawing border. This controls which side of the connector the plug will be displayed, whether the connector goes in vertically or horizontally, and whether the pins are visible.

<b>Connector</b>	Specifies whether the connector inserts vertically or horizontally.
<b>Plug</b>	Specifies which direction the plug portion of the connector comes in relative to the overall plug/receptacle parametric build. The plug representation is displayed with rounded corners. Options include vertical with the plug to the left, vertical with the plug to the right, horizontal with the plug to the bottom, or horizontal with the plug to the top.
<b>Pins</b>	Specifies which pin numbers are visible or hidden on the connector. In the case of a plug/receptacle combination, options include showing both sides, showing the plug only, showing the receptacle only, or hiding both. If you select to make the pins on the plug or receptacle invisible, the attribute and its value are still defined in the block definition on the drawing file. If you selected Plug Only or Receptacle Only for the Type, the pin display options are show or hide only. These show or hide the pin numbers on a single plug or receptacle symbol.



Hidden pins are still present on the symbol, but they are marked invisible. Values assigned to the hidden pins will still show up in various wire connection from/to reports. You can unhide hidden attributes using the Move/Show Attribute tool.

### Size

The values in the edit boxes define the parameters used to build the graphical outline that represents the shell of the connector.

<b>Receptacle</b>	Specifies the width of the receptacle side of the connector. This value can be the same as the plug side.
<b>Plug</b>	Specifies the width of the plug side of the connector.
<b>Top</b>	Specifies the distance from the first pin of the connector to the top end of the connector.
<b>Bottom</b>	Specifies the distance from the last pin of the connector to the bottom end of the connector.
<b>Radius</b>	Specifies the fillet radius for the rounded portion of the plug representation. If left blank or if you enter a 0.0 value, then the corner is drawn without a fillet. If the radius value exceeds the Plug width value, the radius value will be internally set back to be equal to the plug width value.

### Insert



Inserts the connector symbol on the drawing. If a pin count was not defined, an error message appears indicating that you must define a pin count before proceeding. A preview outline of the connector displays for placement on the drawing. It shows angled corners for the plug side of the connector. An 'x' indicates the insertion point of the connector. An arrow indicates the plug side wire connection direction for plug/receptacle or plug-only connector inserts or shows the wire connection direction for a receptacle-only connector insert

Prior to committing the connector outline to the drawing, you can press TAB on your keyboard to flip the connector through four different orientations or press the "V" key to switch between vertical and horizontal orientations.

### Connector layout

 **Ribbon:** Schematic tab ► Insert Components panel ► Insert Connector

drop-down ► Insert Connector. 

 **Toolbar:** Main Electrical 

 **Menu:** Components ► Insert Connector ► Insert Connector

 **Command entry:** AECONNECTOR

In the Insert Connector dialog box, select Allow Spacers/Breaks and click Insert. In the Custom Pin Spaces/Breaks dialog box, click Break Symbol Now.

Selecting Break Symbol Now on the Custom Pin Spaces/Breaks dialog box breaks the connector and displays this dialog box for defining how you want the rest of the pins inserted on the drawing.

### Pin Spacing

Specifies the distance between the pin wire connections. This value initially defaults to the Rung Spacing defined in Drawing Properties ► Drawing Format ► Ladder Defaults - Spacing setting for the drawing file.

#### Fixed Spacing

Creates the connector pin spacing as fixed. The spacing is driven by the Pin Spacing value. If the Pin Spacing edit box is left blank, the fixed spacing value is determined from the drawing's ladder defaults spacing value.

#### At Wire Crossings

Modifies the connector to have the pins coincide with underlying wires. The connector stretches or compresses to match up with underlying wires as it inserts on to the drawing. If the connector has more pins than underlying wires, the excess pins are added at the end of the connector using the default fixed spacing value.

### Pin Insertion

#### Insert All

Creates the connector without further prompts (for example, no option for inserting spacers or for breaking the connector into 2 or more pieces). When you click OK on the Connector Layout dialog box, the block definition is committed to the drawing and the command is complete.

## Allow Spacers/Breaks

Gives you manual control over the insertion of the connector. Displays the Custom Pin Spaces/Breaks dialog box that prompts you for the insertion of each connector pin prior to committing the connector block definition to the drawing file. The running count of pins inserted versus total pins defined for the connector is listed at the top of the dialog box. Select an option for inserting the other pins:

- **Insert Next Connection:** Continues building the connector by inserting the next pin (repeated prompting until all pins are inserted).
- **Add Spacer:** Adds a spacer in place of a pin on the connector in order to leave room for a future pin or to skip over a wire that is not to be broken by the connector. The connector stretches its length to account for this extra blank space.
- **Break Symbol Now:** Breaks connector and begins prompt back at the Connector Layout dialog box. If you terminate the command without inserting the remainder of the connector, you can go to another drawing and restart the command. You can continue with the previous connector or discard the saved data and start with a new one.

---

**NOTE** This insert of a continued, broken connector must be done during the current AutoCAD Electrical session.

---

- **Cancel Custom:** Inserts the remaining pins into the connector without any further prompts.

## Connector pin numbers in use

Lists all of the pins previously used in the project and the available pins that can be assigned to a connector. The connector tag and pin count displays below the title bar in the dialog box.

 **Ribbon:** Schematic tab ► Edit Components panel ► Edit Components

drop-down ► Edit.

 **Toolbar:** Main Electrical

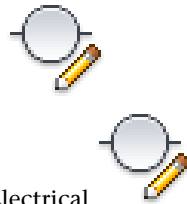

 **Menu:** Components ► Edit Component

 **Command entry:** AEEDITCOMPONENT

Select the connector to edit. In the Insert/Edit Component dialog box, Pins section, click List.

---

**NOTE** You can edit pin numbers when a row is selected in the grid.

---

<b>Pin List</b>	Displays all available pins to be assigned to the parametrically-built connector. The number in parenthesis () indicates the single or pair of pins for the connector. The first column is the value assigned to TERM01 or TERM01P while the second column assigns its number to TERM02 or TERM02J. Select the pin from the list to populate the grid. The Pin list table in the catalog database (default_cat.mdb) supports connectors drawn in the ladder diagram or connector diagram schematics.
<b>x</b>	Displays an 'x' for all pins that are displayed since they are part of the connector and not selected on the block being edited (the pins may be on a different drawing or part of another symbol). Only the pin numbers associated to the block selected are editable; the controls at the bottom of the dialog box are disabled if a pin with an 'x' is selected from the list.
<b>Sheet, Reference</b>	Displays the sheet number and potential reference line number where the connector definition is located in the project.
<b>Plug</b>	Displays the plug pin number. The value changes automatically if you edit it in the Pin Numbers section of the dialog box.
<b>Description</b>	Displays the terminal descriptions that are associated to the wire connection point. The first Description column displays the description for the plug; the second displays the description for the receptacle.
<b>Receptacle</b>	Displays the receptacle pin number. The value changes automatically if you edit it in the Pin Numbers section of the dialog box.
<b>Wire Numbers</b>	Displays the wire numbers on either side of the combination connector or a single wire number based on whether or not the connector is a simple plug or jack.

### Pin Numbers

Displays the plug and receptacle pin numbers for the selected row. Enter a new value in the edit box or click the arrows to increment or decrement both numbers on the plug and receptacle.

---

**NOTE** If you replace pin numbers through editing, the replaced pin numbers may go back into the Pin List if they were originally defined in the Pin List range.

---

### Pin Descriptions

Edits the plug and receptacle terminal descriptions. The value you enter in the edit box displays in the Description column of the grid.

## Bend wires at right angles

### Bend wires at right angles

Bends a wire in a right angle and makes three right angle turns to avoid or add geometry.

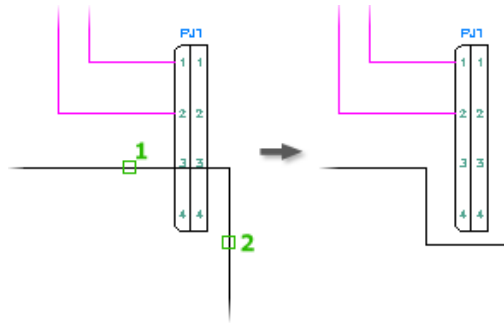

You can modify the wire defined at a right angle. You can replace the right angle bend while maintaining the original wire connections to the components.

---

**NOTE** This tool terminates if the bend attempts to connect two different wire networks or if the bend bypasses more than a single right-angle turn.

---

- 1 Click Schematic tab ► Edit Wires/Wire Numbers panel ► Modify Wires

drop-down ► Bend Wire.

- 2 Select one of the two wires that make up a right-angle turn.

- 3 Select the opposing wire that makes up the right-angle turn.  
The additional wire segments are added based on the right-angle direction.
- 4 Right-click to exit the command.

## Insert multiple bus wiring

### Insert multiple bus wiring

- 1 Click Schematic tab ► Insert Wires/Wire Numbers panel ► Multiple



Bus.

- 2 Set the horizontal and vertical spacing for the wires.
- 3 Select the mode for defining the "starting at" position.
  - **Starting at component wire connection points:** Select the radio button and click OK. Select or window-select the wire connection points on the component.
  - **Starting from another bus:** Select the number of wires (using the buttons or type in the edit box) and click OK. Specify the connection point on the existing wire bus for the first wire of the new bus. Slowly move the cursor over the other existing wires of the bus to allow the new bus wires to connect.
  - **Starting in empty space:** Select the starting direction (Horizontal or Vertical), select the number of wires (using the buttons or type in the edit box), and click OK. Specify the starting point in space for the first wire of the new bus.

During wire insertion, the current wire type displays at the command prompt. If starting at a component or in empty space, you can override this by typing in the hotkey "T" and selecting a new wire type from the Set/Edit Wire Type dialog box. The new wire type becomes the current wire type and the command continues with the wire insertion.

As you pull the wires out, phantom wires display on your cursor indicating the direction and number of wires to be placed on the drawing. You can turn a corner by moving your cursor out of line with the bus. To reverse or flip the turn's phase sequence, press "F" + Enter. The phantom wire

display displays in red when it detects that the routing approaches within a wire connection trap distance of another wire.

- 4 Click a point on the screen to set the endpoint of the wires or press "C" + Enter to lock down the current routing and continue to draw multiple wires. If the bus approaches a multi-connection device, such as a connector, it attempts to align the spacing of the bus wires to match with the wire connections.
- 5 Right-click to create the wires. The wires and wire connection dots insert, and loops or gaps (if configured) automatically insert at wire crossing points.

## Import data from Autodesk Inventor Professional Cable & Harness

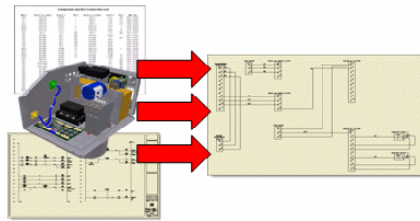

From the XML export from Autodesk Inventor Professional (AIP) into AutoCAD Electrical, you can select from a list of connectors defined in the export, and then place the connectors onto a 2D drawing file. After the connectors are inserted onto the drawing, click Wire on the Connector Selection dialog box to place all wire connections to all components on the drawing file. AutoCAD Electrical parses the file data to determine all wire From and To connections. Once the wiring information is determined, the wires are routed making sure to miss existing geometry on the drawing. The wire insertion tool finds the best possible route with the fewest amount of wire loops in between the connection reducing the requirement on gap pointers. The wires are connected in the appropriate position on the connector representation.

As the wires are inserted, the wire types in the XML file are applied to the Wire Layer in the AutoCAD Electrical drawing. Additionally, wire numbers and cable marker symbols are inserted onto the drawing. The wire numbers are inserted following the drawing's wire number setting (above wire, in-line with wire, or below wire). The first cable marker listed in the XML file is

inserted as the parent and the subsequent markers of the same reference designator (Cable Tag) are inserted as children.

Certain Autodesk Inventor Professional wire property names need to be maintained inside of AutoCAD Electrical. You must make sure that your column header names (set in the Rename User Columns dialog box) match the property names coming out of the Autodesk Inventor Professional XML export (set in the Autodesk Inventor Custom Properties dialog box). For example, the property CORE SIZE maps to a user column of the Create/Edit Wire Type dialog box if there is a column header defined as "CORE SIZE." If mapping does not exist then the data is not maintained inside of your AutoCAD Electrical drawing file.

### **Autodesk Inventor Professional properties mapped to AutoCAD Electrical attributes**

There are four Autodesk Inventor Professional assembly entity types that get general and custom properties: component occurrences, Wire (From/To) occurrences, cable occurrences, and splice occurrences.

<b>Property Name</b>	<b>AIP Property Type</b>	<b>Description</b>
<b>Component Properties</b>		
Connector REF DES	Occurrence	Component RefDes - TAG1 attribute in AutoCAD Electrical
PART NUMBER	Definition	Autodesk Inventor part number - Xdata in AutoCAD Electrical
VENDOR	Definition	Manufacturer - Xdata in AutoCAD Electrical
STRIP LENGTH	Definition, Custom	Save on component - Xdata in AutoCAD Electrical
Various user-defined *	Definition, Custom	Defined in the component library definition (part editing) - Xdata in AutoCAD Electrical
Various user-defined *	Occurrence, Custom	Defined in the harness occurrence level - Xdata in AutoCAD Electrical
<b>Wire Properties</b>		



Wire ID	Occurrence	Unique wire number ID (occurrence name) - AutoCAD Electrical wire number; WIRENO attribute in AutoCAD Electrical
Wire Definition	Definition	Wire library definition data saved in Cable & Harness library XML - wire layer name in AutoCAD Electrical
Various user-defined *	Definition, Custom	Defined in the wire library definition (part editing) - Xdata in AutoCAD Electrical
Various user-defined *	Occurrence, Custom	Defined in the harness occurrence level - Xdata in AutoCAD Electrical
<b>Cable Properties</b>		
Cable ID	Occurrence	Unique cable ID - TAG 1 attribute in AutoCAD Electrical
Cable Definition	Definition	Cable library definition data saved in Cable & Harness library XML - Xdata in AutoCAD Electrical
Cable Wire Name	Definition	Cable conductor ID - RATING1 attribute in AutoCAD Electrical
Various user-defined *	Definition, Custom	Defined in the cable library definition (part editing) - Xdata in AutoCAD Electrical
Various user-defined *	Occurrence, Custom	Defined in the harness occurrence level - Xdata in AutoCAD Electrical
<b>Splice Properties</b>		
Splice ID	Occurrence	Unique splice ID - TAG1 attribute in AutoCAD Electrical
Splice Definition	Definition	Splice library definition data saved in Cable & Harness Library XML - Xdata in AutoCAD Electrical

Various user-defined *	Definition, Custom	Defined in the splice library definition (part editing) - Xdata in AutoCAD Electrical
Various user-defined *	Occurrence, Custom	Defined in the harness occurrence level - Xdata in AutoCAD Electrical

\* Properties that are not defined in Autodesk Inventor Professional but are still usable in AutoCAD Electrical.

## Import connector wire lists

Use the Insert Connector from List tool to import a connector wire list from another application, such as Autodesk Inventor Professional Cable & Harness.

---

**NOTE** If the AutoCAD Electrical drawing is missing one end of the connector or if a connection was not found, wiring information is displayed next to the pin. The information is written into a log file so you know AutoCAD Electrical was unable to resolve the wire connections in the drawing. The log file name is {drawing file name.LOG} and is found in the same folder as the drawing file.

---

- 1 In Autodesk Inventor Professional Cable & Harness, define wire names and connections for your assembly file.
- 2 Define cable tags and conductor IDs and their connections in the assembly file.
- 3 Select the harness ID in the model browser and select Export Harness Data from the Cable and Harness panel.  
You are prompted to select a file name and location for the export of harness component and wiring data. An XML file is created for import into AutoCAD Electrical.
- 4 In AutoCAD Electrical, create a drawing file.
- 5 Click Schematic tab ► Insert Components panel ► Insert Connector



drop-down ► Insert Connector (From List.

- 6 In the Connector List File Selection dialog box, select a connector list file to import into AutoCAD Electrical and click Open.
- 7 In the Connector Selection dialog box, define the connectors to insert onto the drawing.

If the connector is placed or was previously placed into the project, an 'x' displays in the Placed column.

- (Optional) Specify whether to build the connector using fixed pin spacing or to have it compress or expand to match up the pins with underlying wire crossings.
- (Optional) Specify whether to insert the entire connector all at once or to insert it manually, pin by pin, with an option to insert spacers or to break the connector into two or more pieces.
- (Optional) Click the Rotate or Flip buttons to change the display of the connector symbol.
- (Optional) Click Details for more options to define settings for the size, shape, and display of the parametrically built connector symbols.

**8** Select the connectors to insert from the list and click Insert.

**9** Click the insertion point in the drawing for each connector.

**10** In the Connector Selection dialog box, continue selecting the connectors to insert and place them onto the drawing.

**11** When all connectors are placed on the drawing, click Wire It.

Wires are generated in the drawing. Layers and XRECORDS are defined in the drawing and applied to the lines. Wire numbers are also placed in the drawing based on wire placement settings.

---

**NOTE** You can place the connectors on the drawing and add wires at a later time. To do so, follow steps 1 - 9. When you want to add wires, open the Connector Selection dialog box, and click Wire It.

---

## Connector selection

From the XML export from Autodesk Inventor Professional into AutoCAD Electrical, you can select from a list of connectors defined in the export, and then place the connectors onto a 2D drawing file.

 **Ribbon:** Schematic tab ► Insert Components panel ► Insert Connector

drop-down ► Insert Connector (From List).





 **Toolbar:** Insert Connector

 **Menu:** Components ► Insert Connector ► Insert Connector from List

 **Command entry:** AECONNECTORLIST

The first time you run this tool, select the connector list file (.xml, .xls, .mdb, and.csv) in the Connector List File Selection dialog box and click Open. The connector list file is retained in memory for subsequent selections of this tool.

---

**NOTE** If you select to open a spreadsheet or database that contains multiple sheets or tables, the Select Input Source dialog box appears. This dialog box lets you select the sheet or table to open.

---

### Connector List

Columns are not editable. You can sort the connector details alphanumerically by clicking the column headers.

<b>Placed</b>	Displays an "x" if the connector is placed or was previously placed into the project.
<b>Installation</b>	Displays the Installation code for the connector, if defined in the XML import file.
<b>Location</b>	Displays the Location code for the connector, if defined in the XML import file.
<b>Tag</b>	Displays the reference designation (RefDes) for the connector from the Autodesk Inventor Professional (AIP) assembly or tags found in the XML import file.
<b>Total Pins</b>	Displays the total pin count for the tag.
<b>Wired Pins</b>	Displays the number of pins wired inside of the AIP assembly found in the import file.
<b>Description</b>	Displays the occurrence name of the part defined in the AIP browser. The occurrence name is typically the part number of the component, however you can overwrite the name.
<b>Show All/Hide Placed</b>	<b>Show All</b> displays all connectors in the grid whether they have been placed or not while <b>Hide Placed</b> removes previously placed connectors from the grid list.

<b>Connectors</b>	Displays all connectors found in the import file in the grid display. The static text shows the total number of connector components listed in the grid control.
<b>Splices</b>	Displays all splices found in the import file in the grid display. The static text shows the total number of splices listed in the grid control.

---

**NOTE** If there is a selection active when filtering the list and one or more of the selected rows drops out of the display, a warning message displays letting you decide to proceed or not.

---

### Layout

<b>Pin Spacing</b>	Specifies the spacing for the distance between pin connections on their parametrically built connector symbol. The default spacing is defined from the Rung Spacing setting for the drawing. The edited value is persistent for the AutoCAD Electrical session and reverts to the default upon every time you start the application
<b>Fixed Spacing</b>	Creates the connector pin spacing as fixed. The fixed spacing value is driven from the Pin Spacing setting.
<b>At Wire Crossings</b>	Modifies the connector to have the pins meet the underlying wires. AutoCAD Electrical searches the wires and stretches the connector before adding the block definition to the drawing. If there are more pins associated to the connector than there are wires, AutoCAD Electrical finds the wires first, then continues the connector definition at the fixed spacing
<b>Wired Pins</b>	Creates the connector using the number of pins wired in the AIP assembly and found in the import file. This option reduces the size of the overall connector based upon pins used and not library definition. If this option is not selected, the connector is created using the total pins on the connector as defined in the export/import file.
<b>Insert All</b>	Creates the connector without inserting spacers or breaking the connector. When you click Insert the block definition is committed to the drawing and the command is complete.

### Allow Spacers/Breaks

Displays the Custom Pin/Spaces dialog box that prompts you for the insertion of each connector pin before committing the connector block definition to the drawing file. The number of pins inserted in the block definition out of the total number of pins defined in the connector is indicated at the top of the dialog box. Select an option for inserting the other pins:

- **Insert Next Connection:** Continues adding pins to the connector until all are defined
- **Add Spacer:** Adds a spacer in place of a pin on the connector; connector stretches its definition.
- **Break Symbol Now:** Breaks connector and begins prompt back at the connector layout dialog box.
- **Cancel Custom:** Places connector in as if you selected Insert all on the portion it is working on. Does not remove preceding break commands.

### Splice Symbol Name

Defines a symbol to use to display a splice in the wire. Type in a symbol name to use when inserting splices or click Browse to select the symbol name to use. If left blank, once you click Insert, an error message displays. Select a Splice Symbol Name to insert the splice onto the drawing.

### Orientation

Quickly change the connectors orientation before placing it into the drawing file. This orientation change also modifies the preview to reflect the selection.



#### Rotate

Switches the orientation of the parametric connector insertion between horizontal and vertical.



#### Flip

Flips the connector insertion about its long axis.

### Type

Determines the overall style of the connector.

### Plug/Receptacle Combination

Creates the connector as one AutoCAD Electrical block file with both the plug and receptacle.

<b>Wire Number Change</b>	Sets the property of the connector symbol to change the wire number through the connector symbol. By default, the wire numbering is the same on both sides of the connector.
<b>Add Divider Line</b>	Creates the connector with a line down the middle of the block to indicate the separation of the plug and receptacle. This line becomes part of the block definition for the connector.
<b>Plug Only</b>	Creates the connector as a single block file with the plug representation only.
<b>Receptacle Only</b>	Creates the connector as a single block file with the receptacle representation only.

### **Display**

Defines the placement for the connector on the drawing relative to other connectors and the drawing border. This controls which side of the connector the plug is displayed, whether the connector goes in vertically or horizontally, and whether the pins are visible.

<b>Connector</b>	Specifies whether the connector comes into the drawing vertically or horizontally relative to other connectors and the drawing border.
<b>Plug</b>	Specifies which direction the plug portion of the connector comes in relative to the overall plug/receptacle parametric build. The plug representation is displayed with rounded corners. Options include: <ul style="list-style-type: none"> <li>■ Vertical with the plug to the left</li> <li>■ Vertical with the plug to the right</li> <li>■ Horizontal with the plug to the bottom</li> <li>■ Horizontal with the plug to the top</li> </ul>
<b>Pins</b>	Specifies which pin numbers are visible or hidden on the connector. Options include showing both sides, showing the plug only, showing the receptacle only, or hiding both. If you select to make the pins on the plug or receptacle invisible, the attribute and its value are still defined in the block definition on the drawing file.

If you selected Plug Only or Receptacle Only for the Type, the pin display options are show or hide only. These show or hide the pin numbers on a single plug or receptacle symbol.

### Size

Defines the outside shell size for the connector. The values in the edit boxes build the graphical shell that represents the connector on the point to point diagram.

<b>Receptacle</b>	<p>Specifies the overall thickness of the receptacle side of the connector. This value can be the same as the plug side.</p> <p>When the connector is built, the receptacle side wire connection attribute is moved from the insertion point on the divider line to the outside line representing the receptacle. The associated terminal pin attribute (TERM01_) travels half the distance as the wire connection attribute placing itself in the middle between the dimension on the divider line.</p>
<b>Plug</b>	<p>Specifies the overall thickness of the plug side of the connector. This value can be the same as the receptacle side.</p> <p>When the connector is built, the plug side wire connection attribute is moved from the insertion point on the divider line to the outside line representing the plug. The associated terminal pin attribute (TERM01_) travels half the distance as the wire connection attribute placing itself in the middle between the dimension on the divider line.</p>
<b>Top</b>	<p>Specifies the distance from the top or breaking point of the connector to the first or next wire connection point. This feature determines where the top line is drawn relative to the first master symbol insertion point. The distance is used for the entire connector or breaking the connector.</p>
<b>Bottom</b>	<p>Specifies the distance from the bottom or breaking point of the connector to the last or previous wire connection point. This feature determines where the bottom line is drawn relative to the last master symbol insertion point. The distance is used for the entire connector or breaking the connector.</p>
<b>Radius</b>	<p>Specifies the radial dimension of the rounded portion of the plug representation. If left blank, a radius is not created on the plug connector. If you enter a value that exceeds the overall plug side</p>



distance, the radius value is erased. The radius is not created on the plug connector.

### **Pick File**

Displays the Connector List File Selection dialog box to select a new file for import.

### **Wire It**

Reviews connectors placed on the active drawing and runs the wiring commands to make connections between the connectors.

- When both ends of the wire connections are found on the active drawing, the wires are generated between the two points. Wire numbering is added based on current configurations.
- When only one end of the wire connection is found on the active drawing, text is placed next to the connector in the X?WIREnn wire annotation attribute on the connector symbol. This text is overwritten when the second end of the wire is placed on the drawing and the Wire It command is run again.
- When neither connection for a wire is on the active drawing, the wiring command is ignored until you add the connectors into the drawing file.

---

**NOTE** If the AutoCAD Electrical drawing is missing one end of the connector or if a connection was not found, wiring information is displayed next to the pin. The information is written into a log file so you know AutoCAD Electrical was unable to resolve the wire connections in the drawing. The log file name is {drawing filename.LOG} and is found in the same folder as the drawing file.

---

### **Insert**

Upon selection of one or more rows in the grid display, this button is enabled. Once selected, the parametric connector program launches to create a connector image in the drawing.

#### **Single row selection**

Places one connector at a time and returns to the Connector Selection dialog box with the connector row marked as 'x.'

#### **Multiple row selection**

Places the selected connectors in consecutive order. Steps through the list of connectors previously selected in the

dialog box, placing them in the drawing one at a time.  
 After the connectors are created the Connector Selection dialog box appears with the connector rows marked as 'x.'

## Overview of the spreadsheet import file structure

You can select various file types (including XLS, CSV, MDB, and XML) to import into AutoCAD Electrical. For the Insert Connector from List tool to work, the spreadsheet and CSV import file must have the following structure. The spreadsheet for import allows 27 columns per record. The first row in the CSV or XLS file is treated as a header row, and is skipped in the import. All columns must exist and the required fields (bolded) determine the connector to be used in the Connector Selection dialog box.

---

**NOTE** The structure of this file does not apply to an XML import.

---

Position	Field	Purpose	Column Type
1	TYPE1	CMP1: C = Connector/ S = Splice	Text
2	INST1	Installation Code of CMP1	Text
3	LOC1	Location Code of CMP1	Text
4	CMP1	<b>Component 1</b>	<b>Text</b>
5	PIN1	<b>Connected pin on CMP1</b>	<b>Text</b>
6	DESC1	Description of CMP1	Text
7	CAT1	Catalog number for CMP1	Text
8	MFG1	Manufacturer of CAT1	Text
9	ASM1	Assembly code for CMP1	Text
10	TYPE2	CMP2: C = Connector/S = Splice	Text
11	INST2	Installation Code of CMP2	Text
12	LOC2	Location Code of CMP2	Text

13	CMP2	<b>Component 2</b>	<b>Text</b>
14	PIN2	<b>Connected pin on CMP2</b>	<b>Text</b>
15	DESC2	Description of CMP2	Text
16	CAT2	Catalog number of CMP2	Text
17	MFG2	Manufacturer of CAT2	Text
18	ASM2	Assembly code for CMP2	Text
19	WIRENO	Wire number (may be blank)	Text
20	WIRELAY	Wire layer name	Text
21	CBLINST	Cable Installation Code	Text
22	CBLLLOC	Cable Location Code	Text
23	CBL	Cable tag name	Text
24	CBLWCLR	Cable wire (conductor) color	Text
25	CBLCAT	Cable catalog item	Text
26	CBLMFG	Cable catalog manufacturer	Text
27	CBLASM	Cable assembly code	Text

The MDB file must contain a table with the abovementioned 27 columns. Each column should be defined using the VARCHAR data type of an appropriate size to suit the data. The names of the columns in the table are not important, but the position is.

### **Import connector wire lists**

Use the Insert Connector from List tool to import a connector wire list from another application, such as Autodesk Inventor Professional Cable & Harness.

---

**NOTE** If the AutoCAD Electrical drawing is missing one end of the connector or if a connection was not found, wiring information is displayed next to the pin. The information is written into a log file so you know AutoCAD Electrical was unable to resolve the wire connections in the drawing. The log file name is {drawing file name.LOG} and is found in the same folder as the drawing file.

---

- 1 In Autodesk Inventor Professional Cable & Harness, define wire names and connections for your assembly file.
- 2 Define cable tags and conductor IDs and their connections in the assembly file.
- 3 Select the harness ID in the model browser and select Export Harness Data from the Cable and Harness panel.  
You are prompted to select a file name and location for the export of harness component and wiring data. An XML file is created for import into AutoCAD Electrical.
- 4 In AutoCAD Electrical, create a drawing file.
- 5 Click Schematic tab ► Insert Components panel ► Insert Connector



drop-down ► Insert Connector (From List).

- 6 In the Connector List File Selection dialog box, select a connector list file to import into AutoCAD Electrical and click Open.
- 7 In the Connector Selection dialog box, define the connectors to insert onto the drawing.  
If the connector is placed or was previously placed into the project, an 'x' displays in the Placed column.
  - (Optional) Specify whether to build the connector using fixed pin spacing or to have it compress or expand to match up the pins with underlying wire crossings.
  - (Optional) Specify whether to insert the entire connector all at once or to insert it manually, pin by pin, with an option to insert spacers or to break the connector into two or more pieces.
  - (Optional) Click the Rotate or Flip buttons to change the display of the connector symbol.
  - (Optional) Click Details for more options to define settings for the size, shape, and display of the parametrically built connector symbols.

- 8 Select the connectors to insert from the list and click Insert.
- 9 Click the insertion point in the drawing for each connector.
- 10 In the Connector Selection dialog box, continue selecting the connectors to insert and place them onto the drawing.
- 11 When all connectors are placed on the drawing, click Wire It.  
Wires are generated in the drawing. Layers and XRECORDS are defined in the drawing and applied to the lines. Wire numbers are also placed in the drawing based on wire placement settings.

---

**NOTE** You can place the connectors on the drawing and add wires at a later time. To do so, follow steps 1 - 9. When you want to add wires, open the Connector Selection dialog box, and click Wire It.

---

## Connector selection

From the XML export from Autodesk Inventor Professional into AutoCAD Electrical, you can select from a list of connectors defined in the export, and then place the connectors onto a 2D drawing file.

 **Ribbon:** Schematic tab ► Insert Components panel ► Insert Connector

drop-down ► Insert Connector (From List).

 **Toolbar:** Insert Connector

 **Menu:** Components ► Insert Connector ► Insert Connector from List

 **Command entry:** AECONNECTORLIST

The first time you run this tool, select the connector list file (.xml, .xls, .mdb, and.csv) in the Connector List File Selection dialog box and click Open. The connector list file is retained in memory for subsequent selections of this tool.

---

**NOTE** If you select to open a spreadsheet or database that contains multiple sheets or tables, the Select Input Source dialog box appears. This dialog box lets you select the sheet or table to open.

---

## Connector List

Columns are not editable. You can sort the connector details alphanumerically by clicking the column headers.

<b>Placed</b>	Displays an "x" if the connector is placed or was previously placed into the project.
<b>Installation</b>	Displays the Installation code for the connector, if defined in the XML import file.
<b>Location</b>	Displays the Location code for the connector, if defined in the XML import file.
<b>Tag</b>	Displays the reference designation (RefDes) for the connector from the Autodesk Inventor Professional (AIP) assembly or tags found in the XML import file.
<b>Total Pins</b>	Displays the total pin count for the tag.
<b>Wired Pins</b>	Displays the number of pins wired inside of the AIP assembly found in the import file.
<b>Description</b>	Displays the occurrence name of the part defined in the AIP browser. The occurrence name is typically the part number of the component, however you can overwrite the name.
<b>Show All/Hide Placed</b>	<b>Show All</b> displays all connectors in the grid whether they have been placed or not while <b>Hide Placed</b> removes previously placed connectors from the grid list.
<b>Connectors</b>	Displays all connectors found in the import file in the grid display. The static text shows the total number of connector components listed in the grid control.
<b>Splices</b>	Displays all splices found in the import file in the grid display. The static text shows the total number of splices listed in the grid control.

---

**NOTE** If there is a selection active when filtering the list and one or more of the selected rows drops out of the display, a warning message displays letting you decide to proceed or not.

---

## Layout

<b>Pin Spacing</b>	Specifies the spacing for the distance between pin connections on their parametrically built connector symbol. The default spacing is defined from the Rung Spacing setting for the drawing. The edited value is persistent for the AutoCAD Electrical session and reverts to the default upon every time you start the application
<b>Fixed Spacing</b>	Creates the connector pin spacing as fixed. The fixed spacing value is driven from the Pin Spacing setting.
<b>At Wire Crossings</b>	Modifies the connector to have the pins meet the underlying wires. AutoCAD Electrical searches the wires and stretches the connector before adding the block definition to the drawing. If there are more pins associated to the connector than there are wires, AutoCAD Electrical finds the wires first, then continues the connector definition at the fixed spacing
<b>Wired Pins</b>	Creates the connector using the number of pins wired in the AIP assembly and found in the import file. This option reduces the size of the overall connector based upon pins used and not library definition. If this option is not selected, the connector is created using the total pins on the connector as defined in the export/import file.
<b>Insert All</b>	Creates the connector without inserting spacers or breaking the connector. When you click Insert the block definition is committed to the drawing and the command is complete.
<b>Allow Spacers/Breaks</b>	<p>Displays the Custom Pin/Spaces dialog box that prompts you for the insertion of each connector pin before committing the connector block definition to the drawing file. The number of pins inserted in the block definition out of the total number of pins defined in the connector is indicated at the top of the dialog box. Select an option for inserting the other pins:</p> <ul style="list-style-type: none"><li>■ <b>Insert Next Connection:</b> Continues adding pins to the connector until all are defined</li><li>■ <b>Add Spacer:</b> Adds a spacer in place of a pin on the connector; connector stretches its definition.</li><li>■ <b>Break Symbol Now:</b> Breaks connector and begins prompt back at the connector layout dialog box.</li></ul>

- **Cancel Custom:** Places connector in as if you selected Insert all on the portion it is working on. Does not remove preceding break commands.

**Splice Symbol Name** Defines a symbol to use to display a splice in the wire. Type in a symbol name to use when inserting splices or click Browse to select the symbol name to use. If left blank, once you click Insert, an error message displays. Select a Splice Symbol Name to insert the splice onto the drawing.

### Orientation

Quickly change the connectors orientation before placing it into the drawing file. This orientation change also modifies the preview to reflect the selection.



**Rotate**

Switches the orientation of the parametric connector insertion between horizontal and vertical.



**Flip**

Flips the connector insertion about its long axis.

### Type

Determines the overall style of the connector.

<b>Plug/Receptacle Combination</b>	Creates the connector as one AutoCAD Electrical block file with both the plug and receptacle.
<b>Wire Number Change</b>	Sets the property of the connector symbol to change the wire number through the connector symbol. By default, the wire numbering is the same on both sides of the connector.
<b>Add Divider Line</b>	Creates the connector with a line down the middle of the block to indicate the separation of the plug and receptacle. This line becomes part of the block definition for the connector.
<b>Plug Only</b>	Creates the connector as a single block file with the plug representation only.



**Receptacle Only**

Creates the connector as a single block file with the receptacle representation only.

**Display**

Defines the placement for the connector on the drawing relative to other connectors and the drawing border. This controls which side of the connector the plug is displayed, whether the connector goes in vertically or horizontally, and whether the pins are visible.

**Connector**

Specifies whether the connector comes into the drawing vertically or horizontally relative to other connectors and the drawing border.

**Plug**

Specifies which direction the plug portion of the connector comes in relative to the overall plug/receptacle parametric build. The plug representation is displayed with rounded corners.

Options include:

- Vertical with the plug to the left
- Vertical with the plug to the right
- Horizontal with the plug to the bottom
- Horizontal with the plug to the top

**Pins**

Specifies which pin numbers are visible or hidden on the connector. Options include showing both sides, showing the plug only, showing the receptacle only, or hiding both.

If you select to make the pins on the plug or receptacle invisible, the attribute and its value are still defined in the block definition on the drawing file.

If you selected Plug Only or Receptacle Only for the Type, the pin display options are show or hide only. These show or hide the pin numbers on a single plug or receptacle symbol.

**Size**

Defines the outside shell size for the connector. The values in the edit boxes build the graphical shell that represents the connector on the point to point diagram.

**Receptacle**

Specifies the overall thickness of the receptacle side of the connector. This value can be the same as the plug side.

When the connector is built, the receptacle side wire connection attribute is moved from the insertion point on the divider line to the outside line representing the receptacle. The associated terminal pin attribute (TERM01\_) travels half the distance as the wire connection attribute placing itself in the middle between the dimension on the divider line.

<b>Plug</b>	<p>Specifies the overall thickness of the plug side of the connector. This value can be the same as the receptacle side.</p> <p>When the connector is built, the plug side wire connection attribute is moved from the insertion point on the divider line to the outside line representing the plug. The associated terminal pin attribute (TERM01_) travels half the distance as the wire connection attribute placing itself in the middle between the dimension on the divider line.</p>
<b>Top</b>	<p>Specifies the distance from the top or breaking point of the connector to the first or next wire connection point. This feature determines where the top line is drawn relative to the first master symbol insertion point. The distance is used for the entire connector or breaking the connector.</p>
<b>Bottom</b>	<p>Specifies the distance from the bottom or breaking point of the connector to the last or previous wire connection point. This feature determines where the bottom line is drawn relative to the last master symbol insertion point. The distance is used for the entire connector or breaking the connector.</p>
<b>Radius</b>	<p>Specifies the radial dimension of the rounded portion of the plug representation. If left blank, a radius is not created on the plug connector. If you enter a value that exceeds the overall plug side distance, the radius value is erased. The radius is not created on the plug connector.</p>

### **Pick File**

Displays the Connector List File Selection dialog box to select a new file for import.

## Wire It

Reviews connectors placed on the active drawing and runs the wiring commands to make connections between the connectors.

- When both ends of the wire connections are found on the active drawing, the wires are generated between the two points. Wire numbering is added based on current configurations.
- When only one end of the wire connection is found on the active drawing, text is placed next to the connector in the X?WIREnn wire annotation attribute on the connector symbol. This text is overwritten when the second end of the wire is placed on the drawing and the Wire It command is run again.
- When neither connection for a wire is on the active drawing, the wiring command is ignored until you add the connectors into the drawing file.

---

**NOTE** If the AutoCAD Electrical drawing is missing one end of the connector or if a connection was not found, wiring information is displayed next to the pin. The information is written into a log file so you know AutoCAD Electrical was unable to resolve the wire connections in the drawing. The log file name is {drawing filename.LOG} and is found in the same folder as the drawing file.

---

## Insert

Upon selection of one or more rows in the grid display, this button is enabled. Once selected, the parametric connector program launches to create a connector image in the drawing.

<b>Single row selection</b>	Places one connector at a time and returns to the Connector Selection dialog box with the connector row marked as 'x.'
<b>Multiple row selection</b>	Places the selected connectors in consecutive order. Steps through the list of connectors previously selected in the dialog box, placing them in the drawing one at a time. After the connectors are created the Connector Selection dialog box appears with the connector rows marked as 'x.'

# Insert splices

## Insert splices

Inserts a splice symbol selected from the icon menu.

The splice symbol is an in-line connection symbol allowing one or more wires to connect at each end. The default splice symbol triggers a wire number change through the symbol.

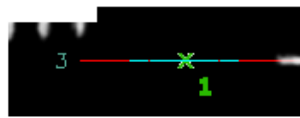

- 1 Click Schematic tab ► Insert Components panel ► Insert Connector

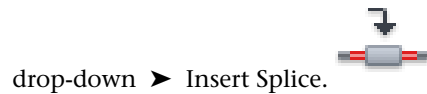

drop-down ► Insert Splice.

The Splice Symbols dialog box displays.

- 2 Select the splice to insert from the icon menu, enter the splice name in the Type it box, or click Browse to browse to and select the symbol from another location.
- 3 Click OK.
- 4 Pick the insertion point on the drawing. Place the symbol on an existing wire, causing the symbol to break the wire or place it in empty space (where you can later draw a wire through the symbol or connect one or more wires to each end of it).

The Insert/Edit Component dialog box displays.

- 5 Assign the catalog information, description, and other information as required.
- 6 Click OK.

## Move from reference to reference

### Move from reference to reference

Use the Surfer tool to move from reference to reference across the project drawing set. A new window opens and the original window closes when Surf is selected unless you hold the Shift key while running the command.

#### Start the Surfer

- 1 Click Project tab ► Other Tools panel ► Surfer drop-down ► Surfer.



- 2 Select a component tag, catalog number, wire number, or item number on the current drawing. Or, press Enter to use the Type it to Surf it dialog box to enter the component tag, catalog number, wire number, or item number.

---

**NOTE** You can also select a report table cell containing any of them to surf on. If the selected cell does not contain any of the surf-able fields, AutoCAD Electrical looks in the selected row for a surf-able field. If the report is the Wire From/To or Component Wire List report, it looks for the Wire Number field first, then a Tag field, and finally a Catalog Number field. If the report is a Bill of Materials report, it looks for a Catalog Number field first, then the Tag field. For all other reports, AutoCAD Electrical looks for the Tag field first, then the Catalog Number field. If a non-surfable cell is selected, it looks for the component tag, then a wire number, and finally a catalog number.

---

All references relating to the component, including panel layout and panel nameplate references, display in the Surf dialog box

- 3 Double-click any reference listed in the Surf dialog box to zoom in on the selected reference. If the reference is on one or more drawings, each drawing opens automatically.

---

**TIP** Use the Type column to select the object to surf to. The codes are as follows:

---

- C - Component Symbol
- P - Parent or Standalone Schematic or One-Line Symbol

---

**NOTE** A one-line symbol is indicated by a "1-" value in the Category column.

---

- T - Terminal
  - W - Wire Number
  - # - Panel Layout Symbol
  - # np - Panel Layout nameplate reference
- 4 Using the Surf dialog box, edit the component, display a BOM listing for each reference or select a different component reference.
  - 5 Click Close.

### Continue a previous surf session

At any time, you can continue a previous surf session from the point where it left off.

- 1 Click Project tab ► Other Tools panel ► Surfer drop-down ► Continue



Surfer.

All references relating to the component, including panel layout and panel nameplate references, are displayed in the Surf dialog box.

- 2 Double-click any reference listed in the Surf dialog box to zoom in on the selected reference.

If the reference is on one or more drawings, each drawing is opened automatically.

- 3 Using the Surf dialog box, edit the component, display a BOM listing for each reference or select a different component reference.
- 4 Click Close.

## Surf

Surfs to related references of an item you select.

**Ribbon:** Project tab ► Other Tools panel ► Surfer drop-down ► Surfer.



**Toolbar:** Main Electrical 2

**Menu:** Projects ► Surfer

**Command entry:** AESURF

Moves from reference to reference across the project drawing set. You can surf on a component tag, catalog number, wire number, item number, or a report table cell containing any of these types of values. Surf a wire network following source and destination signals.

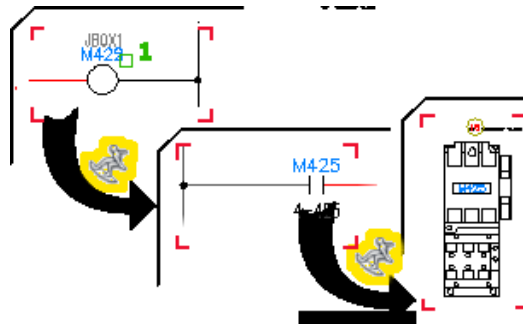

When surfing on a table inserted by the Terminal Strip Editor, you can select the title cell to surf on the Tagstrip value even if the Tagstrip is not included in the title. If you select a cell that is not surfable (such as the Tag, Catalog, or Wire Number cell) the Tagstrip value is surfed for the terminal strip.

---

**NOTE** Your dialog box can differ depending on whether you are moving from reference to reference across the project drawing set or looking for problems related to wire signal source or destination codes.

---

When surfing for source or destination signals, the Surf dialog box displays the type (Src or Dst), sheet/reference value and description.

<b>Show more</b>	Displays the extra non-Installation/Location matching references when in IEC tagging mode. If unselected, only the exact surf matches display in the list. <hr/> <b>NOTE</b> Unavailable if there are not any non-Installation/Location matching references or if you are not in IEC tagging mode. <hr/>
<b>Freshen</b>	changes on the active drawing visible to the surfing tool.
<b>Edit</b>	Edits a reference using the Insert/Edit Component dialog box.
<b>Catalog Check</b>	Displays a BOM listing of the highlighted reference. <hr/> <b>NOTE</b> The reference must have catalog and manufacturer values. <hr/>
<b>Pan</b>	Moves the view in the active viewport.
<b>Zoom Save</b>	Saves the current zoom factor on the WD_M block.
<b>Zoom In</b>	Increases the apparent magnification of the drawing area. The zoom factor is related to the smaller of the active default dimension text size of the drawing (DIMTXT) and text size (TEXTSIZE). The smaller this value is, the closer the zoom is on the reference.
<b>Delete</b>	Delete the instance that is currently displayed. <hr/> <b>NOTE</b> Child and other related devices are not deleted. <hr/>
<b>Pick New List</b>	Changes the component terminal or signal reference you want to surf.



<b>Zoom Out</b>	Reduces the apparent magnification of the drawing area.
<b>Go to</b>	Goes directly to the reference of the highlighted entry.

### Special codes in the surf list box

<b>c</b>	Component symbol
<b>p</b>	Parent or standalone schematic or one-line symbol
	<b>NOTE</b> A one-line symbol is indicated by a "1-" value in the Category column.
<b>t</b>	Terminal
<b>w</b>	Wire number
<b>#</b>	Panel layout symbol
<b># np</b>	Panel layout nameplate reference

## Move between drawings

### Move between drawings

Use Next and Previous to move among the drawings inside of the active project. A new window is opened and the original window is closed when Next or Previous are selected unless you hold the Shift key while running the commands.

- 1 Open a drawing file from the active project.

- 2 Click Project tab ➤ Other Tools panel ➤ Next DWG.  
or



Click Project tab ► Other Tools panel ► Previous DWG.



- 3 Continue moving among the drawings until the file you are looking for is opened.
- 4 Select Window ► {drawing file name} to close the drawing after you modify anything.

You can also close a drawing file by right-clicking the file name in the Project Manager and selecting Close from the context menu.

## Plot one or more drawings

### Plot one or more drawings

Batch plot the full drawing set or a subsection of the drawing set.

- 1 Click Project tab ► Project Tools panel ► Manager.



- 2  On the Project Manager, click the arrow on the Publish/Plot tool, and select Plot Project.
- 3 Select one or more drawings to plot.
- 4 Click OK.
- 5 In the Batch Plotting Options and Order dialog box, select the layout tab to plot.
- 6 Select the output device.
  - **Use plot config (.pc3):** Click to use an existing plotter configuration file (.pc3), enter the file name or click Browse to select the file.

A plotter configuration file contains information such as the device driver and model, the output port to which the device is connected, and various device-specific settings.
  - **Use layout tab's default:** Click to use the default plotter configuration.

- 7 Click Detailed Plot Configuration mode to turn on or turn off the options set within the Detailed Plot Configuration Option dialog box.
- 8 Click ON or OFF.
- 9 Select the order to output the plot:
  - **OK:** Output plots in the selected order.
  - **OK-Reverse:** Output plots in the reverse order.
- 10 Click OK to save any open drawings.
- 11 Click OK Project.

## Batch plotting options and order

Batch plot the full drawing set or a subsection of the drawing set.

 **Ribbon:** Project tab ► Project Tools panel ► Manager. 

 **Toolbar:** Main Electrical 2 

 **Menu:** Projects ► Project ► Project Manager

 **Command entry:** AEPROJECT

On the Project Manager, click the arrow on the Publish/Plot tool  , and select Plot Project. Select the drawings to process and click OK.

### Layout tab to plot

Selects the layout tab to plot. Change the tab by selecting from the pick list.

### (Optional) For each drawing

#### Run a pre-plot command script file

Run an optional script file containing a list of commands to execute BEFORE the plot command is issued.

The default script file name is preplot.scr, located in AutoCAD Electrical user subdirectory.

**Run a post-plot command script file**

Run an optional script file containing a list of commands to execute AFTER the plot command is issued. The default script file name is postplot.scr, located in AutoCAD Electrical user subdirectory.

---

**NOTE** Changes to drawings are not saved during the plotting process. Additionally, the plot time and date stamp text is discarded after the plot is complete. To preserve changes made during the plotting process, add the QSAVE command into the pre- or post-plot script file.

---

**Output device name**

A plotter configuration file contains information such as the device driver and model, the output port to which the device is connected, and various device-specific settings.

**Use plot config (.pc3)**

Use an existing plotter configuration file (.pc3).

**Use layout tab's default**

Use the default plotter configuration.

---

**NOTE** If you are plotting to a file you must also select the **Yes: plot to=** option. The plot file name is generated automatically based on the drawing name. The plot folder is the same as the drawing.

---

**Detailed plot configuration mode**

Turns detailed plot configuration options on or off.

**Optional page setup name**

Enter an optional page setup name when plot configuration options are turned off.

**Pick list (from current drawing)**

Select an option for the pick list when plot configuration options are turned off.

**Plot to file**

Enter a subdirectory to plot to or leave blank to plot to the subdirectory where the drawings are located.

## Order

OK	Outputs plots in the selected order
OK-Reverse	Outputs plots in the reverse order.

# Project-wide utility

## Project-wide utilities

Provides the means for operations on wire numbers, component tags, attribute text, wire types, and item numbers. You can define scripts and apply them project-wide.

 **Ribbon:** Project tab ► Project Tools panel ► Utilities. 

 **Toolbar:** Project 

 **Menu:** Projects ► Project-Wide Utilities

 **Command entry:** AEUTILITIES

Select project drawings and perform any of the following:

- Erase, reset, fix, or unfix wire numbers.
- Fix or unfix component tags.
- Fix or unfix item numbers.
- Clear signal cross-referencing.
- Run a user-specified script file.
- Change attribute text size or style.
- Import wire types from another drawing or drawing template.

You can have multiple drawings open at any time. However, to maximize performance and memory usage, minimize the number of open drawings when running project-wide commands.

### **Wire Numbers**

Select to keep wire numbers the same, erase specified wire numbers, reset specified wire numbers, or set wire numbers to fixed or normal.

### **Signal Arrow Cross-reference text**

Select to maintain the signal arrow cross-reference text or to remove all signal arrow cross-reference text across the current project.

### **Parent Component Tags: Fix/Unfix**

Select to maintain the component tags or to set all parent component tags to fixed or normal across the current project.

### **Item Numbers: Fix/Unfix**

Select to maintain the item numbers or to set all item numbers to fixed or normal across the current project. If you run [Resequence Item Numbers](#) on page 1602 later on, fixed item numbers do not change.

### **Change Attribute**

#### **Change Attribute Size**

Click Setup to select the attributes to change, and then enter the height and width definitions for the selected attributes.

---

**NOTE** If you do not want the attribute height or width to change, do not enter a value definition.

---

#### **Change Style**

Click Setup to select a text font to apply to the text style used on component attributes.

### **For each drawing**

Enter the name or browse to a command script file to use for each drawing in the current project or to purge all blocks.

### **Wire Types**

Imports wire types defined on another drawing or drawing template. Enter the drawing or template name or browse to it using the browse button. The program reads the specified drawing and extracts all wire type information.

Click Setup to display the [Import Wire Types](#) on page 903 dialog box where you:

- Select the wire types to import.
- Define whether to overwrite any Wire Numbering and USERn differences for existing wire types.
- Define whether to overwrite color and linetype differences for existing wire layers.

## Create a project-wide script file

### Create a project-wide script file

You can run an AutoCAD script file against one or more drawings in the current project.

For example, to ensure that all drawings are set to model space and zoomed extents:

- 1 Create an ASCII text script file called model\_ext.scr.
- 2 Add the following AutoCAD commands and AutoLISP functions:  
(setvar "TILEMODE" 0)  
ZOOM EXT  
(load "c:\\myprograms\\chktitle.lsp")

---

**NOTE** Double backslashes must be used.

---

```
CHKTITLE  
QSAVE
```

- 3 Test the script for proper operation.
  - On the current drawing, issue the SCRIPT command, followed by the script file name.
  - If the script runs properly, it is ready for project-wide use.

## Renumber Ladder References

### Renumber Ladders

Renumbers ladder references project-wide.

 **Ribbon:** Schematic tab > Edit Wires/Wire Numbers panel > Modify

Ladder drop-down > Renumber Ladder Reference.



 **Toolbar:** Ladders



 **Menu:** Wires > Ladders > Renumber Ladder Reference

 **Command entry:** AERENUMBERLADDER

1st drawing, 1st ladder, 1st line reference number      Enter the first ladder line reference number.

2nd drawing and beyond

Select an option for ladders on subsequent drawings.

- Use next sequential reference - increment from the last line reference on the previous drawing.
- Skip, drawing to drawing count - enter an amount to skip for the first ladder reference of the next drawing.

## Project-wide update or retag

### Project-wide update or retag

Resequences or updates component tags, wire numbers, cross references, signal references, select drawing properties, ladders, and title blocks.

 **Ribbon:** Project tab > Project Tools panel > Update/Retag.



 **Toolbar:** Project



 **Menu:** Projects > Project-Wide Update/Retag

 **Command entry:** AEPROJUPDATE

In one command, modify drawing properties and sheet values, renumber ladders, retag components, redo cross referencing, and update title blocks.



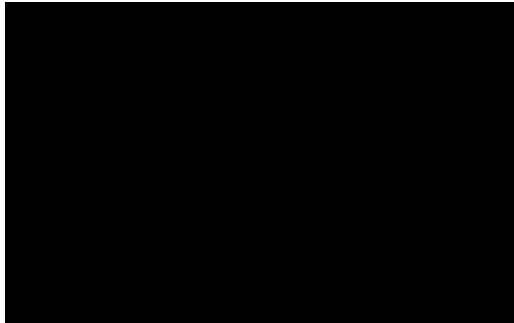

### **Component Retag**

Retag all nonfixed components.

---

**NOTE** If Ladder References Resequence is selected, the component retag process is performed after the ladder resequencing is complete.

---

### **Component Cross-reference Update**

Updates the cross-referencing for components on selected drawings.

---

**NOTE** Cross-references are updated after other options such as component retag or ladder resequencing are performed.

---

### **Wire Number and Signal Tag/Retag**

Sets options for wire number retagging.

Click Setup to display the Wire Tagging (project-wide) dialog box. Here you can insert or update wire numbers associated with wire line networks across a project

### **Ladder References**

Rennumbers each ladder sequentially.

#### **Resequence Setup**

Defines options for starting reference numbers and how to sequence ladders from drawing to drawing.

#### **Renumber Ladders dialog box**

Rennumbers the ladder for the selected drawings from the active project.

- 1** Enter the ladder reference number for the first drawing.

- 2 For all subsequent drawings:
  - Select to use the next sequential reference.
  - Select Skip, drawing to drawing count to enter an amount to skip for the first ladder reference of the next drawing.

### Bump Up or Down

Moves ladder references up if drawings were added to the middle of a project or moves ladder references down if drawings were removed from the project.

---

**NOTE** Enter a negative number to move ladder references down.

---

### Sheet (%S value)

Automates resequencing the sheet value on consecutive drawings.

#### Resequence - Start with

Enter a number to start the resequencing.

#### Bump-Up/Down by

Select to move the current sheet value up or down by a given count.

### Drawing (%D value)

Performs a project-wide update of the %D "DWG NAME" parameter of the drawing.

### Other Configuration Settings

Updates the drawing parameters related to component, cross-reference, and wire tagging modes and format project-wide.

### Title Block Update

Automates updating title block information for the active drawing or the entire project drawing set.

## Track drawing changes

The Mark/Verify tool can help you track changes made to a project drawing set during any phase in the engineering process. Before you send your drawings out for review, use the Mark option. Each AutoCAD Electrical component, wire number, and beginning ladder reference is invisibly marked and referenced in a table in the scratch database file of the current project. When the drawings are returned, you can use the Verify option to generate a report of changes. The report includes a list of all added, changed, copied, and deleted components and wire numbers. Changes made using AutoCAD, AutoCAD LT, or AutoCAD Electrical are all detected.

For AutoCAD Electrical to detect if a component or wire number is deleted, it must reference the MARKVERIFY table that is saved in the database file of the project. If the project database file is erased after the Mark option is run, then a subsequent Verify command cannot report deleted items since it is limited to reporting only changes involving new inserts, copies, and edited components and wire numbers.

The Verify command detects and reports changes to the following:

- Component TAG name (such as CR101 changed to CR101A)
- Description text
- Switch position text, rating values
- Beginning PLC module address value
- Terminal pin numbers (both stand-alone terminals and component pin numbers)
- Catalog number, manufacturer, assembly code value
- Location/Installation code values
- Wire numbers
- Beginning ladder reference number
- Wire Source/Destination codes
- Deleted items - Project database maintained

## Track changes made to a drawing set

Use this tool to insert comments in your drawings before sending them for review. Once the drawings are returned to you, run this tool again to see any changes that were made to the drawing set.





- 1 Click Project tab ► Project Tools panel ► Mark/Verify DWGs.
- 2 Specify to mark either the project or the current drawing.
- 3 Specify to mark AutoCAD Electrical components. You can also select:
  - Include non-AutoCAD Electrical blocks to mark all blocks even if they do not carry AutoCAD Electrical intelligence.
  - Select Include wires/lines to detect changes to any lines or wires in the drawings.
- 4 Click OK.
- 5 Enter your initials and any comments about the drawing set, and then click OK. This information (along with the current time and date) is included in later reporting.

Invisible flags are placed on the wire numbers and component tags. These flags do not change the appearance or functioning of the drawings. However, they may increase the drawing size by a small amount.
- 6 After you make edits to the drawings or receive the drawings back from your client, reopen the drawings in AutoCAD Electrical so you can verify the changes.
- 7 Use the Mark/Verify Drawings command to report the accumulated changes made to the drawing set.
- 8 Specify to verify the drawings and click OK.

A list of the detected changes is displayed in a report dialog box.
- 9 Specify to display the data in the AutoCAD Electrical report format, save the report, or print the changes. You can also select to surf through the list to examine each detected change in context.

## Mark and verify

Marks drawings to track changes. Verifies drawings to report changes.

 **Ribbon:** Project tab ► Project Tools panel ► Mark/Verify DWGs. 

 **Toolbar:** Project 

 **Menu:** Projects ► Mark/Verify Drawings

 **Command entry:** AEMARKVERIFY

Creates a list of changes made after the drawings are marked. The report includes added, changed, copied, and deleted components or wire numbers. Detects changes made using AutoCAD, AutoCAD LT, or AutoCAD Electrical.

This tool places invisible data on each component to track additions and modifications. Information is written to the project database file to check for deleted components. Your drawings must be named and part of the active project to use this command.

---

**NOTE** This command writes information to the project database file that is used to check for deleted components. Your drawings must be named and part of the active project to use this command.

---

<b>Mark/verify drawing or project</b>	Specifies to mark or verify the active drawing or process all drawings in the current project.
<b>Mark</b>	Places invisible information on all AutoCAD Electrical components including blocks not created in AutoCAD Electrical, lines, and wires.
<b>Verify</b>	Generates a list of changes since the drawings were marked.
<b>Remove</b>	Removes all invisible mark data.
<b>Previous</b>	Redisplays the last check mark exception report.
<b>Surf</b>	Continues surfing on exceptions generated the last time the mark/verify command was used.
<b>Current drawing statistics</b>	Displays any mark data found on the drawing.

# Translate description text

## Translate description text

Converts description or switch position component text from one language to another. When AutoCAD Electrical finishes it displays a report listing what was successfully translated and what was not. You can use this report to surf to the problem areas (where a phrase could not be translated) and make manual edits one by one.



- 1 Click Project tab ► Other Tools panel ► Language Conversion.
- 2 Select to run the command on the entire project, the active drawing, selected drawings, or on selected objects in the drawing.
- 3 Select the "From" and "To" languages to use.
- 4 Specify if multiple lines of the component description text are translated based on exact or partial matches.  
By default, the conversion looks for exact matches on the description labels you select with partial match as an option.
- 5 Click OK and the components or drawings you want to process.

---

**TIP** You can add more phrases to the translation table using the Edit Language Database File tool (Project tab ► Other Tools panel ► Edit Language Database) and rerun the language swap to obtain more satisfactory results.

---

## Language conversion



Translates component description text from one language to another. Description text and switch position text is processed on schematic and panel components.

 **Ribbon:** Project tab ► Other Tools panel ► Language Conversion.



 **Toolbar:** Project



 **Menu:** Projects ► Language Conversion ► Language Conversion  
 **Command entry:** AELANG

<b>Run language swap on</b>	Performs language translation on the entire project, the active drawing, selected drawings, or on selected objects in the drawing.
<b>From To</b>	Translates from the current language to another language.
<b>What to do</b>	Translates the selected item.
<b>Translation on</b>	Determines if multiple lines of the component description text are translated based on exact or partial matches.

---

**NOTE** By default, translation is performed on exact matches only.

---

## Edit: language lookup file

Opens the current language table for review and modification. The default table is wd\_lang1.mdb

 **Ribbon:** Project tab ► Other Tools panel ► Edit Language Database.



 **Toolbar:** Project

 **Menu:** Projects ► Language Conversion ► Edit Language Database File

 **Command entry:** AELANGDB

<b>Select language</b>	Selects a predefined language. <hr/> <b>NOTE</b> Language matches are NOT case sensitive, but phrase substitutions are made exactly as entered in the language table. <hr/>
<b>Add a Language</b>	Adds a new column to the database with a blank entry for each existing phrase associated with the new language name.
<b>Delete Language</b>	Deletes a language from the predefined language table.

<b>Phrase list in selected language</b>	Displays a phrase list for the selected language.
<b>New phrase</b>	Adds a blank entry to the end of each language list and the translations for phrase list at the bottom of the dialog box.
<b>Copy phrase</b>	Adds a copy of each translation of the selected phrase to the end of each language list.
<b>Delete phrase</b>	Deletes all translations of the selected phrase from the database.
<b>Translations for phrase above - Select to edit</b>	Displays phrases from the selected language. Double-click a phrase to edit.

## Publish to the Web

### Publish to the Web

Creates HTML Web pages from drawings you select in the active project.

- 1 Enter AEPUBLISH2WEB at the command prompt.
- 2 In the Publish to Web dialog box, select a location to store the drawing files.
- 3 Select an image format.
  - **DWF:** Design web format files are vector-based representations of drawing (.DWG) files.

---

**NOTE** DWF is the recommended image format as it supports intra-drawing surfing from a component tag or component description list.

---

  - **JPEG:** Joint Photographics Experts Group files are raster-based. We do not recommend this format for large files that contain text.
  - **PNG:** Portable Network Graphics files are raster-based like JPEG images, but PNG provides a higher quality output.
- 4 Click OK.



- 5 Select one or more drawing to publish to the Web.
  - **Do All:** Selects all drawings from the project drawing list to publish to the web.
  - **Process:** Selects one or more drawings from the project drawing list to publish to the web.
  - **Reset:** Moves all selected drawings back to the project drawing list.
  - **Un-select:** Moves one or more drawings back to the project drawing list.
  - **by Section/sub-section:** Selects drawings by sections and subsections.
- 6 Click OK.
- 7 Enter a name for the project banner for the Web page.
- 8 Enter one or more project titles for the Web page.
- 9 Select the method to output drawing images to the Web page.
- 10 Click OK.
- 11 Enter an output device name.
- 12 Press ENTER to select no as the default when prompted to select to write the plot to a file [Yes/No]
- 13 Press ENTER to select no as the default when prompted to save change to page setup [Yes/No]
- 14 Press ENTER to select yes as the default when prompted proceed with plot [Yes/No]

The progress of the plot job is displayed. When complete, you are notified that the plot and publish job is complete.

### **Publish to web - temporary folder for build**

Creates a Web page of selected drawings in the current project. The Web pages and associated support files are saved in the specified folder, enabling preview, and testing before posting to the Web. If the folder does not exist, one is created.

 **Ribbon:** Project tab ► Project Tools panel ► Manager.



On the Project Manager, click the arrow on the Publish/Plot tool , and select Plot Project. Select the drawings to process and click OK.

 **Menu:** Projects ► Publish to Web

 **Command entry:** AEPUBLISH2WEB

<b>DWF</b>	Design Web format files are vector-based representations of drawing (.DWG) files. <hr/> <b>NOTE</b> DWF is the recommended image format as it supports intra-drawing surfing from a component tag or component description list. <hr/>
<b>JPEG</b>	Joint Photographics Experts Group files are raster-based. We do not recommend this format for large files that contain text.
<b>PNG</b>	Portable Network Graphics files are raster-based like JPEG images, but PNG provides a higher quality output.

## AutoCAD Electrical publish to Web - banner, title text, options

 **Ribbon:** Project tab ► Project Tools panel ► Manager. 

On the Project Manager, click the arrow on the Publish/Plot tool , and select Plot Project. Select the drawings to process and click OK.

 **Menu:** Projects ► Publish to Web

 **Command entry:** AEPUBLISH2WEB

Specify or create a folder location for the files to save and click OK. Select the drawings to process and click OK.

<b>Banner</b>	Creates the text string that forms the banner for the Web page. The default is the .WDP file name and its path for the current project.
<b>Title Text</b>	Creates the text that appears below the banner. The default is the current project's first four project description LINEx values.

<b>Layout to output</b>	Creates the drawing images using the AutoCAD Plot to DWF function. The plot mode can be Model, Layout1, or As Saved.
<b>Configuration name</b>	Uses the plot configuration file for generating the .DWF drawing images. <hr/> <b>NOTE</b> To override, set WD_DWF_PC3 in the wd.env environment settings file. <hr/>
<b>Build intra-drawing surf pick lists</b>	Automates the surf and zoom capabilities on components on the drawing image displayed on the Web. Intra-drawing surfing is available once the page creation process is complete. <hr/> <b>NOTE</b> This option slows the .DWF plotting process. <hr/>
<b>Allow drag and drop</b>	Copies the .DWG files or creates .DXF file copies of the drawings and posts them on the Web page. You can drag these files from the Web page into an AutoCAD session.

## Publish to DWF

### Publish to DWF

Publishes drawings in the active project to DWF files.

- 1 Enter AEPUBLISH2DWF at the command prompt.
- 2 Select one or more drawing to publish to DWF.
  - **Do All:** Selects all drawings from the project drawing list to publish to DWF.
  - **Process:** Selects one or more drawings from the project drawing list to publish to DWF.
  - **Reset:** Moves all selected drawings back to the project drawing list.
  - **Un-select:** Moves one or more drawings back to the project drawing list.
  - **by Section/sub-section:** Selects drawings by sections and subsections.
- 3 Select Publish Setup options.

4 Click OK.

5 Click Publish.

The progress of the plot job is displayed. When complete, you are notified that the plot and publish job is complete.

## Title Block Utility

### Title block

AutoCAD Electrical can link to your drawing title block if it consists of an AutoCAD block with attributes. The title block border drawing can be inserted as a block on any AutoCAD drawing or on an [AutoCAD drawing template](#) on page 1228 file.

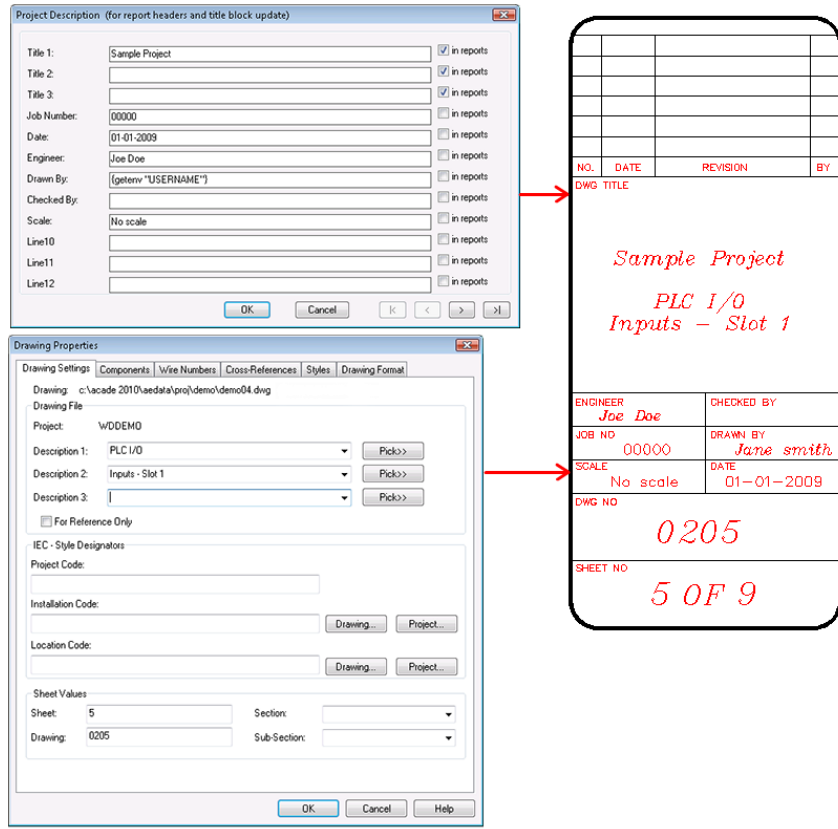

## Create a title block

The title block is a border drawing inserted as an AutoCAD block on another drawing. The title block utility can update attributes on the title block.

- 1 Start a blank new drawing.
- 2 Draw your drawing border using standard AutoCAD commands and objects.
- 3 Enter ATTDEF at the command prompt to insert attribute definition objects.

**NOTE** When the border drawing is inserted as a block on another drawing, attribute definition objects become attributes.

- 4 Enter the Tag name, for example DESC1, DESC2, SHEET, SHEET\_TOTAL.
- 5 Set any other attribute definition properties and values.
- 6 Select OK.
- 7 Specify the insertion point.
- 8 Repeat for each attribute definition for the title block.
- 9 Save the border drawing as a *DWG* file.

This drawing is inserted as a block on another drawing. It can be also be inserted when [creating a drawing template](#) on page 1228 file, *DWT*. A drawing template file is used to provide consistency in the drawings that you create by providing standard style, settings, layers, and border.

---

**NOTE** Run [Title Block utility setup](#) on page 1210 with this border drawing file active if using the [WD\\_TB attribute method](#) on page 1216 to link AutoCAD Electrical values to the title block.

---

## Title Block utility setup

### Title Block setup overview

AutoCAD Electrical can link project description lines and some of the drawing properties to attributes on the drawing title block . There are two methods:

- [WD\\_TB attribute method](#) on page 1216 - mapping information embedded on the title block.
- [WDT file method](#) on page 1218 - external attribute mapping file.

During a title block update, AutoCAD Electrical follows this sequence to determine which method to use.

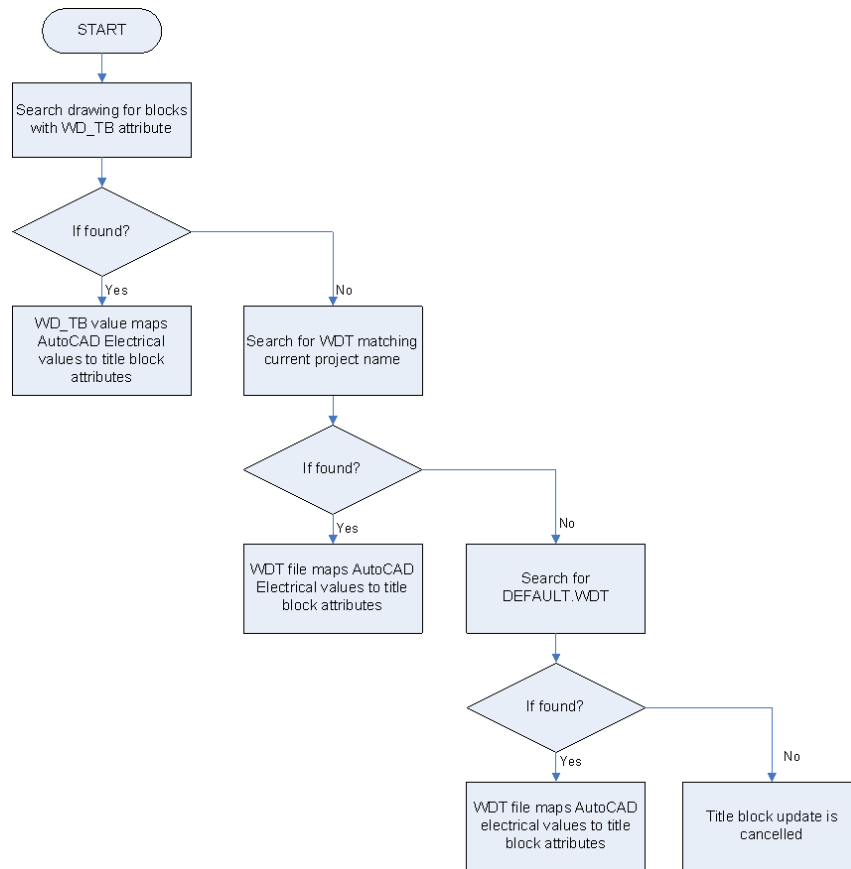

### AutoCAD Electrical values

AutoCAD Electrical can map the following project and drawing specific values to attributes on the title block.

Mapping Code	Description
LINEx	project description line, where "x" is the project description line number
SHEET	sheet number value (the %S value) assigned in the Drawing Properties dialog box
SHEETMAX	number of drawings in the active project (the "N" value in title block "SHEET x of "N")

<b>Mapping Code</b>	<b>Description</b>
<b>DWGNAM</b>	drawing name value (the %D value) assigned in the Drawing Properties dialog box
<b>DD1 (or DWGDESC), DD2, DD3</b>	the drawing descriptions assigned in the Drawing Properties dialog box
<b>DWGSEC</b>	optional Section code assigned in the Drawing Properties dialog box
<b>DWGSUB</b>	optional Subsection code assigned in the Drawing Properties dialog box
<b>FILENAME</b>	drawing file name without path or extension
<b>FULLFILENAME</b>	drawing file name with path and extension
<b>FILENAMEEXT</b>	drawing file name with .dwg extension only
<b>IEC_P</b>	IEC Project value of the drawing assigned in the Drawing Properties dialog box
<b>IEC_I</b>	IEC Installation value of the drawing assigned in the Drawing Properties dialog box
<b>IEC_L</b>	IEC Location value of the drawing assigned in the Drawing Properties dialog box
<b>PLOTTIME</b>	current time (24-hr military format)
<b>PLOTTIME12</b>	current time (12 hr am/pm format)
<b>PLOTDATE</b>	current date (MM:DD:YYYY format)
<b>PLOTDATEMMDDYY</b>	current date (MM:DD:YY format)
<b>PLOTDATEYYMMDD</b>	current date (YY:MM:DD format)
<b>PLOTDATEYYYYMMDD</b>	current date (YYYY:MM:DD format)

You can also map [user-defined values](#) on page 1215 such as fixed text within quotes, environment variables, system variables, and AutoLISP variables.



---

**NOTE** The Title Block Setup utility maps the appropriate codes based on selections on the Title Block Setup dialog box.

---

### Set up multiple descriptions

AutoCAD Electrical allows three description lines per drawing. If more description lines are needed, each description line can be broken into multiple pieces by the “|” character. Each piece is then mapped to a different attribute on the title block.

For example, to map the first description line to three attributes, use this format:

```
attrname1|attrname2|attrname3=DD1
```

Then, in the Description 1 value in the [Drawing properties: drawing settings tab](#) on page 220 dialog box, delimit the value with “|” at the break points. For example, “Main cabinet|120VAC|PLC I/O”. The Update Title Block command splits this string of text across the three title block attributes.

---

**NOTE** The Title Block Setup command does not support this method. Use a text editor, such as Notepad, to edit your *WDT* file manually. Use the DDEDIT command to edit the WD\_TB attribute definition manually.

---

### Setup title block update

Creates or modifies the link between title block attributes and project and drawing values.



**Ribbon:** Project tab ► Other Tools panel ► Title Block Setup.

**Menu:** Projects ► Title Block Setup

**Command entry:** AESETUPTITLEBLOCK

The link between AutoCAD Electrical and the title block is defined by either an external *WDT* text file or by an invisible WD\_TB attribute added to your existing title block. If the *WDT* method is used, you can use a project-specific file or the Default.wdt file. In either case, the title block attribute names are mapped to the project-wide LINEx values and to several drawing-specific setting values.

## Method 1

<b>Project.wdt</b>	Create a project-specific mapping file that only references for drawings in the current project. The file name is the same as the project name with a .wdt extension.
<b>DEFAULT.WDT</b>	Create a default mapping file in the project's subdirectory that is referenced if a project-specific file is not found and if a WD_TB attribute is not present in the title block.
<b>DEFAULT.WDT</b>	Create a default mapping file in the default AutoCAD Electrical subdirectory that is referenced if a project-specific file is not found and if a WD_TB attribute is not present in the title block.

---

**NOTE** When using this method, open a drawing that contains the title block inserted as a block before running the Title Block Setup.

---

## Method 2

The title block contains an invisible attribute with a value that defines the mapping between the title block and AutoCAD Electrical. No external *WDT* file is required because the mapping information is self-contained on the title block.

The attribute name = WD\_CODE mapping information is encoded on the WD\_TB attribute on the title block of the drawing. The value of the attribute gives the mapping information in the format of a semi-colon delimited text string. For example:

```
TITLE-1=LINE1;TITLE-2=LINE2;SH=SHEET;SH_TOTAL=SHEET_MAX
```

where project wide values for LINE1 and LINE2 codes update attributes TITLE-1 and TITLE-2. The %S sheet value is copied to the title block attribute SH, and the number of drawing files in the project is written out to attribute SH\_TOTAL.

---

**NOTE** When using this method, open the title block base drawing that contains the attribute definition objects before running the Title Block Setup.

---

## Title block setup

Defines what pieces of AutoCAD Electrical project data or drawing specific data that AutoCAD Electrical should copy to that attribute. The information is written to the [WDT file](#) on page 1218 or the [WD\\_TB attribute](#) on page 1216 depending on the method chosen.







**Ribbon:** Project tab ► Other Tools panel ► Title Block Setup.

**Menu:** Projects ► Title Block Setup

**Command entry:** AESETUPTITLEBLOCK

Specify the title block link method, enter a block name, and click OK.

<b>Title block name</b>	Lists the available title block names.
<b>Add New</b>	Adds new title blocks to the project. Enter a block name. For multiple blocks, separate with a comma. For example, DEMOTBLK,DEMOTBLK2,DEMOTBLK3
<b>Edit</b>	Edits the selected title block.
<b>Remove</b>	Removes the selected title block.
<b>Pick on</b>	Selects an attribute directly on the drawing if you do not know the name of attribute.
<b>Attribute</b>	Specifies the attribute to use for the drawing, project, or plotting value. Select an attribute from the list.
<b>Project Values / Drawing Values / Plotting Values</b>	Shows the project, drawing-specific, and plotting values.
	Displays the first set of description lines
	Displays the previous set of description lines
	Displays the next set of description lines
	Displays the last set of description lines, where one of the lines has a value
<b>User Defined</b>	Maps attributes to text constants or AutoLISP values.

## **Title block setup (user-defined)**

Assigns text constants and AutoLISP expressions to a title block attribute.



 **Ribbon:** Project tab ► Other Tools panel ► Title Block Setup.

 **Menu:** Projects ► Title Block Setup

 **Command entry:** AESETUPTITLEBLOCK

Specify the title block link method, enter a block name, and click OK. Click User Defined on the Title Block Setup dialog box.

<b>Current User-defined Assignments</b>	Lists the attributes and assigned text constant or AutoLISP expression.
<b>Attributes</b>	Modify an existing link by selecting it from the attribute list. To clear an existing link, select -none- from the attribute list.
<b>Text constant or AutoLISP expression</b>	Enter a text constant or an AutoLISP expression to assign to the attribute. For example, you can assign (getvar "LOGINNAME") to attribute DWGBY, or you can assign YourName to DWGBY.
<b>Update list</b>	Adds the text constant or AutoLISP expression to the user-defined list.

## WD\_TB attribute method

An invisible attribute on a title block of the drawing, named "WD\_TB," is encoded with the mapping information. This method eliminates the need for an external mapping text file. The format is <attribute name>=<LINEx>;<attribute name>=<LINEx>. Here is an example of what the WD\_TB attribute value would be:

```
PROJ_TITLE=LINE1;DRAW_TITLE1=LINE2;DRAW_TITLE2=DWGDESC;PROJ_NUM=LINE4
```

Use the Title Block Setup utility to assign this information to the WD\_TB attribute. The Title Block Setup utility works directly on the WD\_TB attribute definition and cannot be used on a drawing with the title block inserted as a block. Open the base title block *DWG* file before running the Title Block Setup.

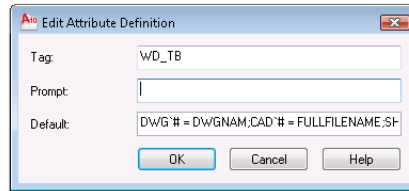
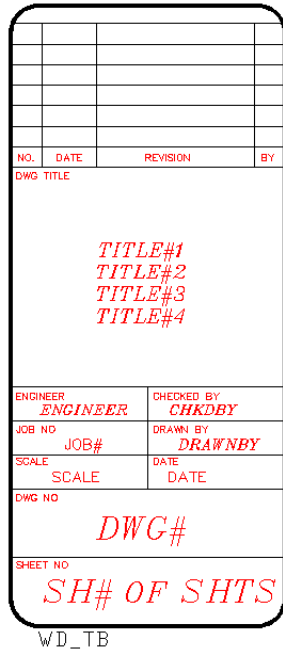

## Map a title block using the WD\_TB attribute method

Create a mapping for the title block on the WD\_TB attribute definition.

- 1 Open the title block base drawing that contains the attribute definition objects.

---

**IMPORTANT** Do not open a drawing with the title block inserted as a block.

---

- 2 Click Project tab ➤ Other Tools panel ➤ Title Block Setup. 

- 3 Select the title block link method: **Method 2: WD\_TB attrib.**

An invisible attribute contained in the title block defines the attribute mapping.

- 4 Click OK.

Title Block Setup reads the attribute definitions and the Title Block Setup dialog box displays.

---

**NOTE** An alert displays if no attribute definition objects are found.

---

- 5 In the Title Block Setup dialog box, select the attribute from each list to map to its corresponding AutoCAD Electrical value.
- 6 Click Drawing Values to assign drawing specific and plotting values.
- 7 Click User Defined to map attributes to text constants or AutoLISP values.
- 8 Click OK.
- 9 Title Block Setup updates the WD\_TB attribute definition with the selected mappings.

---

**NOTE** If a WD\_TB attribute definition does not exist, the Title Block Setup inserts it at 0,0.

---

- 10 Save the drawing.

Insert this title block base drawing as a block on each drawing in the project before running the Title Block Update.

## WDT file method

A text file defines which AutoCAD Electrical values are mapped to the drawing title block attributes. Use the Title Block Setup utility or any text editor to create or modify the *WDT* mapping file. When using the Title Block Setup utility, open a drawing with the title block inserted as a block.

### File Format

The mapping file is created and updated by the Title Block Setup utility. It can be edited directly using a text editor such as Notepad or WordPad. It is important to maintain the following format.

The first line defines the title block names. For example,

BLOCK = TITLE

---

**NOTE** Title Block Update ignores any line that begins with a semi-colon.

---

If your title block/revision block consists of multiple blocks, you can encode two or more block names into the *WDT* file. For example, the following line tells AutoCAD Electrical to look for and update blocks called TB, TB-REV, and TB-ISSUE. Each block name is separate by a comma.

BLOCK = TB,TB-REV,TB-ISSUE

You can also use wildcards to define title blocks. For example, the drawing could have any of three different title block sizes, named TITLE-SIZEB, TITLE-SIZEC, or TITLE-SIZED. The following line tells AutoCAD Electrical to find and update the title block no matter what size is used on the drawing.

BLOCK = TITLE-SIZE\*

The lines that follow the block definition, map the attribute names on that block to specific AutoCAD Electrical values. For example,

PROJ\_TITLE = LINE1

DRAW\_TITLE1 = LINE2

DRAW\_TITLE2 = DWGDESC

PROJ\_NUM = LINE4

SX = SHEETMAX

SH = SHEET

PLOTTIME = PLOTTIME

PLOTDATE = PLOTDATE

---

**NOTE** The AutoCAD Electrical batch plotting routine uses the PLOTTIME and PLOTDATE entries in this file.

---

Place a backwards apostrophe character in front of the attribute name if the attribute tag name of the title block contains one or more wildcard characters (# @ . \* ? ~ [ ] -). For example, '[REV] = LINE5, where the title block attribute name is [REV].

## Map a title block using the WDT file method

Create a mapping for the title block using an external *WDT* file.

- 1 Open a drawing that contains the title block inserted as a block.



- 2 Click Project tab ► Other Tools panel ► Title Block Setup.

- 3 Select a title block link method:**Method 1:**

- **<Project> .WDT file** Create a project-specific mapping file with the same file name as the active project name and a *WDT* extension.

- **DEFAULT.WDT** Create a default mapping file in the same folder as the project file. This file is used if a project-specific file does not exist.
- **DEFAULT.WDT** Create a default mapping file in the default AutoCAD Electrical support folder. This file is used if a project-specific file does not exist and no *DEFAULT.WDT* file exists in the project folder.

---

**NOTE** Title Block Update looks first for any blocks with a *WD\_TB* attribute. If the *WD\_TB* attribute is found, the *WDT* file is ignored.

---

4 Click OK.

If the .WDT file exists:

- Click View to view and edit the file.
- Click Overwrite to create a file.
- Click Edit to modify the existing file.

---

**NOTE** If no existing file is found, identify the AutoCAD block name of the title block.

---

- 5 In the Title Block Setup dialog box, select the attribute from each list to map to its corresponding AutoCAD Electrical value.
- 6 Click Drawing Values to assign drawing specific and plotting values.
- 7 Click User Defined to map attributes to text constants or AutoLISP values.
- 8 Click OK.
- 9 Title Block Setup updates or creates the *WDT* file with the selected mappings.

## Title Block Update

AutoCAD Electrical can link to your drawing title block if it consists of an AutoCAD block with attributes. The title block utility:

- Automates project-wide title block updates.
- Supports multiple title blocks per drawing.
- Maps AutoCAD Electrical project description lines to specific attributes.



- Maps AutoCAD Electrical per-drawing values to specific attributes.
- Maps AutoLISP values, system variables, or environment variables to specific attributes.
- Provides two title block linking methods, [WD\\_TB attribute](#) on page 1216 and [WDT file](#) on page 1218.

## Update the title block project-wide

Before running the Title Block Update, enter the project [description](#) on page 203 lines and [drawing values](#) on page 220 that are mapped to attributes on the title block.



- 1 Click Project tab ► Other Tools panel ► Title Block Update.  
The Update Title Block dialog box displays.

- 2 Select the values to update on the title block, along with SHEET and SHEETMAX if new drawings were added to your project.

---

**NOTE** If you want to save these selections, click Save. The settings are stored in the default.wdu file.

---

- 3 (Optional) Select Resequence sheet %S value.  
Renumbers the sheet values and changes the sheet max value. It is commonly used when drawings are added to the project drawing set.
- 4 (Optional) Select Activate each drawing to process.

---

**NOTE** This option is necessary if there are user-defined values mapped to the title block that require activating the drawing to retrieve the values.

---

- 5 Click OK Project-Wide.
- 6 Select to process all the drawings in the project and click OK.

## Update title block

Automates updating title block information for the current drawing or the entire project drawing set. Project and drawing specific settings are linked to one or more attributes contained in the title block.

This tool assumes that you have a border with mapped attributes using the *WDT* file or a mapping attribute (WD\_TB) inside of the border. It specifies which attribute on the border to update with text from the Update Title Block dialog box.

---

**NOTE** The labels for each Project Description Line are customized by an optional [WDL on page 1224](#) file.

---

 **Ribbon:** Project tab ► Other Tools panel ► Title Block Update. 

 **Toolbar:** Main Electrical 2





 **Menu:** Projects ► Project ► Project Manager

From Project Manager, right-click the project name and select Title Block Update.

 **Command entry:** AEUPDATETITLEBLOCK

### Select Lines to Update (Project Description Lines)

Lists project-wide LINE1 through LINExx description lines.

Select All	Selects the displayed set of project description lines
Clear All	Clears the displayed set of project description lines
	Displays the first set of description lines
	Displays the previous set of description lines
	Displays the next set of description lines
	Displays the last set of description lines, where one of the lines has a value

**Save** Saves the list of checked boxes to a file called default.wdu. The default.wdu file is saved in the user folder.

### **Select Lines to Update (per-drawing values)**

Lists drawing-specific values.

<b>Drawing Description</b>	The drawing descriptions assigned in the Drawing Properties dialog box. Up to three drawing descriptions can be added to a drawing. The drawing description codes DD1 (or DWGDESC), DD2 and DD3 are used for the three description lines.
<b>Drawing Section</b>	The drawing section code assigned in the Drawing Properties dialog box.
<b>Drawing Sub-section</b>	The drawing subsection code assigned in the Drawing Properties dialog box.
<b>Filename</b>	The file name without an extension.
<b>File/extension</b>	The file name with the appropriate extension.
<b>Full Filename</b>	The full file name and the path name where the file is located.
<b>P</b>	IEC Project value of the drawing assigned in the Drawing Properties dialog box.
<b>I</b>	IEC Installation value of the drawing assigned in the Drawing Properties dialog box.
<b>L</b>	IEC Location value of the drawing assigned in the Drawing Properties dialog box.
<b>Drawing (%D value)</b>	The %D value of the drawing settings.
<b>Sheet (%S value)</b>	The %S value of the drawing settings.
<b>Sheet maximum</b>	The maximum count of drawings in the project.

### Resequence sheet %S values

Renumbers the sheet number for each drawing in the project set or for a selected portion of the project drawing set.

### Activate each drawing to process

Specifies to activate every drawing so you can update the title block lines on selected drawings in the project. This option is necessary only if there are some user-defined values that require activating the drawing.

### OK Active Drawing Only

Updates the text for the selected lines on the active drawing only.

### OK Project-wide

Updates the text for the selected lines on selected drawings in the project.

## Customize LINEx Labels

The title block and project description dialog boxes in AutoCAD Electrical display generic labels like “LINE1”, “LINE2”, and so on. You can change these labels so they match up with the link to the title block. For example, you have linked the AutoCAD Electrical data “LINE10” value to the “DRAWN\_BY” attribute on the title block. What you want to see when AutoCAD Electrical displays a title block-related dialog box is not “LINE10” but “Drawn by.” A text file with a *WDL* extension defines the custom labels.

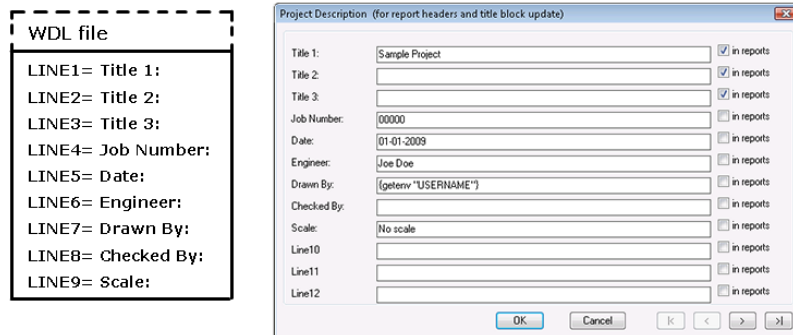

AutoCAD Electrical looks in the following order for a *WDL* file.

- 1 **<projname>\_wdtitle.wdl** - where <projname> matches the name of the active project in the same folder as the project *WDT* file.
- 2 **default\_wdtitle.wdl** - in the same folder as the project *WDT* file.
- 3 **default\_wdtitle.wdl** - in a folder in the AutoCAD Electrical search sequence.

The file contains one line per label in the format *LINEx=label*. The entries do not have to be in order and line numbers can be skipped. For example:

LINE1 = Project Title 1

LINE2 =Title 2

LINE3 = Title 3

LINE4 = Project Number

## Customize LINEx labels

The generic LINEx labels in the various title block and project description dialog boxes can be customized.

- 1 Use any generic text editor such as Notepad or WordPad to create one of the following files:
  - **<projname>\_wdtitle.wdl** - where <projname> matches the name of the active project. Save the file in the same folder as the project *WDT* file.
  - **default\_wdtitle.wdl** - save the file in the same folder as the project *WDT* file.
  - **default\_wdtitle.wdl** - save the file in a folder in the AutoCAD Electrical search sequence.
- 2 The file contains one line per label in the format *LINEx=label*. The entries do not have to be in order and line numbers can be skipped.

LINE1 = Project Title 1

LINE2 =Title 2

LINE3 = Title 3

LINE4 = Project Number

LINE5 = Date

LINE6 = Engineer

LINE7 = Drawn By

LINE8 = Checked By

LINE9 = Scale

- 3 Save and exit the text file.
- 4 Open AutoCAD Electrical and test.

### Search sequence for .wdl files

You can create different *WDL* files for different projects. The search sequence is as follows:

- 1 Look in the same folder as the .WDP file for the project, for a file called <projname>\_WDTITLE.WDL where <projname> matches the name of the active project.
- 2 Look in the same folder as the .WDP file for the project for a file called DEFAULT\_WDTITLE.WDL.
- 3 If WD\_ACADPATHFIRST flag is present in wd.env file, look for DEFAULT\_WDTITLE.WDL in ACAD paths.
- 4 Look for DEFAULT\_WDTITLE.WDL in the AutoCAD Electrical USER folder.
- 5 Look for DEFAULT\_WDTITLE.WDL in the base AutoCAD Electrical folder.
- 6 If WD\_SUP\_ALT is defined in the wd.env file, look for DEFAULT\_WDTITLE.WDL in the specified path.
- 7 Look for DEFAULT\_WDTITLE.WDL in ACAD paths (if WD\_ACADPATHFIRST flag is not set in the wd.env).

## Map AutoLISP values to the title block

You can map system variable values, or values extracted by AutoLISP programs, to attributes on the title block.

- [Assign](#) on page 1227 a variable to one of the project description lines which then maps to an attribute on the title block.
- [Map](#) on page 1215 a variable directly to an attribute on the title block

---

**NOTE** If the expression is a full AutoLISP function, it must return a string value (not an integer, real, list, or nil value). The program must be encoded into the project description data as "(load 'filename.lsp')." It must be self-starting upon load.

---

### See also:

- [Set project descriptions](#) on page 203

### Assign a variable to a project description line

For example, the environment variable "USERNAME" contains a value that must show up on the drawing title block.

- 1 Click Project tab ► Project Tools panel ► Manager. 
- 2 In the Project Manager, right-click the project name, and select Descriptions.
- 3 Enter the AutoLISP function (getenv "USERNAME") on one of the description lines.
- 4 Select OK.
- 5 Using either the [WD\\_TB attribute method](#) on page 1216 or the [WDT file method](#) on page 1218, map the project line to the appropriate attribute on the title block, for example "DWGBY".

- 6 Click Project tab ► Other Tools panel ► Title Block Update.   
The Update Title Block dialog box displays.
- 7 Check the appropriate project description line for update.

---

**NOTE** Check the Activate each drawing to process if the variable is drawing specific.

---

- 8 Select the drawings for updating.  
During the title block update AutoCAD Electrical evaluates the expression, and writes that value out to the attribute that is mapped to the project

description line (mapped in the .wdt file or on the WD\_TB attribute value carried by the title block).

## Drawing template

A drawing template file is used to provide consistency in the drawings that you create by providing standard styles and settings.

When a drawing template file is used to start a new drawing it can:

- Predefine AutoCAD Electrical drawing properties such as component tagging, wire numbering format, and so on.
- Predefine layers and layer properties.
- Predefine wire layers.
- Provide your drawing border and title block.

By default, drawing template files are stored in the *template* folder, where they are easily accessible.

### Create a drawing template

A drawing template file is used to provide consistency in the drawings that you create by providing standard style, settings, layers, and border.

- 1 Start a new drawing using the acad.dwt template.
- 2 Click Home tab ► Block panel ► Insert.
- 3 Browse to the title block *DWG* created for the border.
- 4 Click OK.
- 5 Insert at 0,0,0.

---

**NOTE** Attributes are invisible if no default values are assigned.

---

- 6 Click Schematic tab ► Other Tools panel ► Drawing Properties.





- 7 Set the default drawing properties such as component tagging, wire numbering, cross-referencing, and so on.
- 8 Click OK.
- 9 Click Schematic tab ► Edit Wires/Wire Numbers panel ► Create/Edit



Wire Type.

- 10 Add wire layers as needed. Set the properties, color, linetype, and lineweight for each layer.
- 11 Click OK.
- 12 Enter SAVEAS at the command prompt.
- 13 Enter the file name.
- 14 Set the file type as AutoCAD Drawing Template (\*.dwt).
- 15 Click Save.

### See also:

- [Create a title block](#) on page 1209
- [Use wire layers](#) on page 895
- [Project and Drawing Properties](#) on page ?



## Overview of the Icon Menu Wizard

Use the Icon Menu Wizard to customize the icon menus easily.

- Copy, cut, and paste icons from one submenu into another.
- Drag icons to place those icons that are commonly used at the top, and those icons that are used less frequently at the bottom of the window.
- Create new icons to use when inserting components.
- Add new icon menu pages.

Once you click OK in any of the Add Icon dialog boxes, the following happens:

- The new icon is created and saved depending on the status of the WD\_SLB code in the environment file (.env).  
If WD\_SLB is disabled in the environment file, the Images folder of the corresponding icon menu .dat file is created (if it does not exist) and new images are saved here.

**Windows XP:** C:\Documents and Settings\{username}\Application Data\Autodesk\AutoCAD Electrical {version}\{release}\{country code}\Support\Images\

**Windows Vista, Windows 7:**

C:\Users\{username}\AppData\Roaming\Autodesk\AutoCAD Electrical {version}\{release}\{country code}\Support\Images\

If you browsed to an existing image, the image is copied to the Images folder.

If WD\_SLB is enabled, the Images folder corresponding to the folder defined by the WD\_SLB is created (if it does not exist) and new images are saved here. If the WD\_SLB value is "N:\Electrical\Menu" then the folder

N:\Electrical\Menu\Images is created and used. If you browsed to an existing image, the image is copied to the Images folder.

---

**NOTE** You can enclose the image path within quotation marks if you do not want the images copied to the Images folder. The .dat file saves the absolute path instead. For example, if the image file edit box contains "C:\Desktop\push\_button.png," then the push\_button.png is not copied to the Image folder.

---

- The new icon is added to the end of the existing icon images in the Symbol Preview window of the Icon Menu Wizard dialog box.
- The relative path of the new icon information is written to the .dat file once you click OK in the Icon Menu Wizard dialog box. However, the complete path of the block or circuit is saved in the .dat file if the Block Name edit box or the File name edit box contains the complete path of the drawing file.

## Add or modify icons using the icon menu wizard

Adds new or edits existing items and pages on the AutoCAD Electrical icon menus.

- Copy, cut, and paste icons from one submenu into another.
- Drag icons within the Symbol Preview window to rearrange. Place icons used commonly at the top.
- Create an icon for components or circuits you insert, or an AutoCAD Electrical command you run.

The Icon Menu Wizard can be used to add or modify icons for both the schematic and panel symbol libraries. You can add new menu pages to the AutoCAD Electrical icon menu, and then populate them with your own custom symbols. Each new page can have icon selections that cascade down to other new menu pages.

### Add a new icon to the menu

- 1 Create an AutoCAD Electrical compatible library symbol. For schematic symbols, follow the guidelines regarding the symbol ".dwg" file naming convention and required attributes.



- 2 Click Schematic tab ► Other Tools panel ► Icon Menu Wizard.
- 3 On the Select Menu File dialog box, select the menu file (.dat) to modify and click OK.
- 4 On the Icon Menu Wizard dialog box, select Add ► Component to add a new icon to the menu.

You can alternately select Command, New Circuit, Add Circuit or New Submenu depending on which type of icon you want to add.

  - Component: Adds an icon that inserts a component into the drawing.
  - Command: Adds an icon that runs an AutoCAD Electrical command when selected.
  - New Circuit: Creates a circuit and adds the icon (that is created from a new circuit) that inserts the circuit into the drawing.
  - Add Circuit: Adds an icon (created from an existing circuit) that inserts the circuit into the drawing.
  - New Submenu: Adds an icon that opens a submenu page when selected. You can then select an icon from the submenu to insert the specified component into the drawing or run an AutoCAD Electrical command.
- 5 On the Add Icon - Component dialog box, define the required information (such as symbol file name, image file, and block name) for the icon menu button. To select the image file of the icon, enter text, and then click Browse to select an existing image file. Click Pick to select a block from the active drawing (the block name then appears in the Image File edit box). Or, click Active to select the active drawing to use as the icon image file name.

The icon options to define are different depending on which type of icon you are adding to the menu file (.dat).
- 6 Click OK.

The new icon displays at the bottom of the Symbol Preview window.
- 7 On the Icon Menu Wizard dialog box, click OK.

- 8 Click Schematic tab ► Insert Components panel ► Insert Components



drop-down ► Icon Menu.

On the Insert Component dialog box, select the new icon.

### Edit the properties of an existing icon in the menu

- 1 Create an AutoCAD Electrical compatible library symbol. For schematic symbols, follow the guidelines regarding the symbol ".dwg" file naming convention and required attributes.



- 2 Click Schematic tab ► Other Tools panel ► Icon Menu Wizard.
- 3 On the Select Menu File dialog box, select the menu file to modify and click OK.
- 4 On the Icon Menu Wizard dialog box, right-click the icon to edit and select Properties.
- 5 On the Properties - Component (Command, Circuit or Submenu) dialog box, edit the required information (such as symbol file name, image file, and block name) for the icon menu button. To select the image file of the icon, enter text, and then click Browse to select an existing image file. Click Pick to select a block from the active drawing (the block name then appears in the Image File edit box), or click Active to select the active drawing to use as the icon image file.  
The icon options to define are different depending on which type of icon you are editing.
- 6 Click OK.

### Icon menu wizard

Modifies the icon menu. You can rearrange icons using drag and drop in the Symbol Preview window, add icons, create new submenus, delete icons, cut/copy/paste icons, and modify icon properties.

 **Ribbon:** Schematic tab ► Other Tools panel ► Icon Menu Wizard.





 **Toolbar:** Miscellaneous

 **Menu:** Components ► Symbol Library ► Icon Menu Wizard

 **Command entry:** AEMENUWIZ

---

**NOTE** You can lock the icon menu (.dat) file using the Windows File Properties dialog box so unauthorized users cannot modify the .dat file. In the Windows File Properties dialog box, set the file attributes to Read-only.

---

<b>Menu</b>	The tree structure is created by reading the icon menu file (.dat). The displayed nodes are based on the order of arrangement of submenus defined in the .dat file.
<b>Tabs</b>	<ul style="list-style-type: none"><li>■ <b>Menu:</b> Changes the visibility of the Menu tree view.</li><li>■ <b>Up one level:</b> Displays the menu that is one level before the current menu in the Menu tree view.</li><li>■ <b>Views:</b> Changes the view display for the Symbol Preview window. The current view option is indicated with a check mark. Options include: Icon with text, Icon only or List view.</li><li>■ <b>Add:</b> Modifies the icon menu by adding icons for commands, components, or circuits or add a new submenu.</li></ul>
<b>Symbol Preview window</b>	<p>Displays the symbol images corresponding to the menu or the submenu selected in the Menu section.</p> <p>You can drag icons within the Symbol Preview window for re-arrangement (multiple selection is allowed) such as placing commonly used icons at the top and rarely used icons at the bottom of the window.</p> <hr/> <p><b>NOTE</b> When you move the cursor over an icon, the icon name, and block/circuit/command name display as tooltip information.</p> <hr/>

### Right-click menus

#### Options for the Menu tree structure view

Right-click a menu or submenu in the Menu tree structure view to display the following options:

- **Expand/Collapse:** Toggles the visibility of the menus.

- **New submenu:** Creates a submenu in the tree structure and the Symbol Preview window.
- **Cut:** (available for submenus only) Removes the selected submenu and its contents from the list. You can then paste the submenu into another submenu or a main menu.

---

**NOTE** The menu number does not change during a Cut and Paste. For example, if you cut menu number 100 and paste it into another submenu page, the pasted menu page is still menu number 100.

---

- **Copy:** (available for submenus only) Makes a copy of the highlighted submenu and stores it in the Paste clipboard. You can then paste the submenu and its contents into another submenu or a main menu.

---

**NOTE** A new menu number is created for the pasted submenu. The next available menu number (greater than 99) is assigned.

---

- **Paste:** Adds the copied or cut submenu to the highlighted menu or submenu.
- **Delete:** (available for submenus only) Deletes the submenu and all related content.
- **Properties:** Opens a Properties dialog box to modify the existing menu or submenu properties like the menu name, image, or submenu title. The existing data in the \*.dat file is overwritten with your changes once you click OK.

### Options for the Symbol Preview window

Right-click an icon or in empty space in the Symbol Preview window to display the following options:

- **View:** Changes the view display for the Symbol Preview window. The current view option is indicated with a check mark. Options include: Icon with text, Icon only or List view.
- **Add icon:** Adds new icons (component, command, or circuit) or adds an existing circuit into the Symbol Preview window.
- **New submenu:** Creates a submenu in the Symbol Preview window and the tree structure.



- **Cut:** Removes the selected icon from the Symbol Preview window. You can then paste the icon into the desired submenu.
- **Copy:** Makes a copy of the highlighted icon and stores it in the Paste clipboard. You can then paste the icon into the appropriate submenu.
- **Paste:** Adds the copied or cut icon to the highlighted submenu.
- **Delete:** Deletes the icon.
- **Properties:** Opens a Properties dialog box to modify the existing symbol icon properties like the icon name, image, or block names. The existing data in the \*.dat file is overwritten with your changes once you click OK.

## Add icon - component

The icon name and symbol block name are saved in the active \*.dat file (such as ACE\_JIC\_MENU.DAT) once you click OK the Icon Menu Wizard dialog box. The icon then displays at the end of the existing icon images in the Symbol Preview window of the Insert Component dialog box.

 **Ribbon:** Schematic tab ► Other Tools panel ► Icon Menu Wizard.



 **Toolbar:** Miscellaneous

 **Menu:** Components ► Symbol Library ► Icon Menu Wizard

 **Command entry:** AEMENUWIZ

Select the menu file to modify and click OK. In the Icon Menu Wizard dialog box click Add and then select Component.

You can also access this dialog box by right-clicking in the Symbol Preview window of the Icon Menu Wizard dialog box and selecting Add Icon ► Component.

---

**TIP** To determine which \*.dat file is active, in the Project Properties dialog box, Project Settings tab, Library, and Icon Menu Paths section, expand the Schematic Icon Menu File option. It is the schematic icon menu file listed in the \*.wdp file.

---

## Icon Details

Defines the icon name and image.

<b>Preview</b>	Displays an image preview of the specified image file.
<b>Name</b>	Specifies the name to appear in the icon, the description text, and the tool tip for the icon.
<b>Image file</b>	<p>Specifies the image file to use for the new icon. You can enter the image file name (or complete path) or select it using one of the following methods:</p> <ul style="list-style-type: none"><li>■ <b>Browse:</b> Finds an existing image to use for the icon. You can browse for .sld or .png images.</li><li>■ <b>Pick:</b> Selects an existing block name on the current drawing to use as the image file name. For example, if you select block HPB11, the image file name edit box displays "HPB11".</li><li>■ <b>Active:</b> (It is unavailable if the drawing is a new drawing and was not saved) Selects the active drawing name to use as the Image file. For example, if the active drawing name is "demo005", then the image file edit box has "demo005" listed as the file name.</li></ul> <p>The browsed image is copied to the Images folder and saved as a relative path in the .dat file. Enclose the image path in quotation marks if you do not want the image copied to the Images folder. Save the complete path instead of the relative path in the .dat file. The entered image file name can be names like "PB1" or "CONTROL RELAY," file names with an extension such as "pb1.png". Or, it can follow the syntax {slide_library or dll file (slide or .png)}. For example, "S2(pb)" or "S7(control_relay)".</p> <hr/> <p><b>NOTE</b> The image file name cannot contain invalid characters such as \ / : " ? &lt; &gt;   and only .png and .sld image files are supported.</p> <hr/>
<b>Create PNG from current screen image</b>	Creates the .png image file from the current screen image. If the specified image file does not exist, this

option is selected by default. If you do not want to create the icon from the displayed image of the current drawing, clear the check box.

---

**NOTE** This option is unavailable if you enter an image file name with the syntax {slide\_library or dll file (slide or .png)}. For example, "S2(pb)" or "S7(control\_relay)". It is also unavailable if the Image File edit box contains the image file path instead of the image file name.

---

**Zoom**

(Available only when Create PNG from current screen image is selected.) Zooms in on the current screen image using the AutoCAD Zoom command. Once you exit Zoom mode and press Enter, the dialog box redisplay so you can finish defining the new icon.

**Location**

(This option appears once the Image file is specified.) Indicates the full path of the image file location where the new images are created or the browsed images are copied to. If you entered a file name with the syntax {slide\_library or dll file (slide or .png)} for the image file, the path of the .dat file or the WD\_SLB folder displays here.

**Block Name to Insert**

Defines the symbol block that is inserted when you click the icon in the Insert Component dialog box.

**Block Name**

Specifies the symbol block name. The file name of the symbol can be typed into the edit box or you can enter it using one of the following methods:

- Browse: Finds an existing WBlocked drawing (\*.dwg) file to assign to the icon. In this case the complete path of the drawing file is inserted in the edit box.
- Pick: Selects an existing block on the current drawing (for example, block recently created with Symbol Builder). WBlocked version (.dwg) must exist.
- Active: Inserts the active drawing as a block.

**Add icon - command**

An icon can be configured to trigger an AutoCAD command, trigger an AutoCAD Electrical command, or run a script file. The icons that trigger insertion of multi-pole schematic symbol assemblies, one-line symbols, and panel footprints are examples that require encoding of special AutoCAD Electrical commands.

The icon name and command string are saved in the active \*.dat file (such as ACE\_JIC\_MENU.DAT) once you click OK on the Icon Menu Wizard dialog box. The icon then displays at the end of the existing icon images in the Symbol Preview window of the Insert Component dialog box.

---

**NOTE** If you are modifying the panel menu file, use this option for inserting panel symbols. Also, use it for inserting 3-pole schematic symbols or one-line symbols.

---

 **Ribbon:** Schematic tab ► Other Tools panel ► Icon Menu Wizard.



 **Toolbar:** Miscellaneous

 **Menu:** Components ► Symbol Library ► Icon Menu Wizard

 **Command entry:** AEMENUWIZ

Select the menu file to modify and click OK. On the Icon Menu Wizard dialog box click Add, and then select Command.

You can also access this dialog box by right-clicking in the Symbol Preview window of the Icon Menu Wizard dialog box and selecting Add Icon ► Command.

---

**TIP** To determine which \*.dat file is active, in the Project Properties dialog box, Project Settings tab, Library, and Icon Menu Paths section, expand the Schematic Icon Menu File option. It is the schematic icon menu file listed in the \*.wdp file.

---

### Icon Details

Defines the icon name and image.

<b>Preview</b>	Displays an image preview of the specified image file.
<b>Name</b>	Specifies the name to appear in the icon, the description text, and the tool tip for the icon.

**Image file**

Specifies the image file to use for the new icon. You can enter the image file name (or complete path) or select it using one of the following methods:

- **Browse:** Finds an existing image to use for the icon. You can browse for .sld or .png images.
- **Pick:** Selects an existing block name on the current drawing to use as the image file name. For example, if you select block HPB11, the image file name edit box displays "HPB11."
- **Active:** (It is unavailable if the drawing is a new drawing and was not saved) Selects the active drawing name to use as the Image file. For example, if the active drawing name is "demo005," then the image file edit box has "demo005" listed as the file name.

The browsed image is copied to the Images folder and saved as a relative path in the .dat file. Enclose the image path in quotation marks if you do not want the image copied to the Images folder. Save the complete path instead of the relative path in the .dat file. The entered image file name can be names like "PB1" or "CONTROL RELAY," file names with an extension such as "pb1.png," or it can follow the syntax {slide\_library or dll file (slide or .png)}. For example, "S2(pb)" or "S7(control\_relay)."

---

**NOTE** The image file name cannot contain invalid characters such as \ / : " ? < > | and only .png and .sld image files are supported.

---

**Create PNG from current screen image**

Creates the .png image file from the current screen image. If the specified image file does not exist, this option is selected by default. If you do not want to create the icon from the displayed image of the current drawing, clear the check box.

---

**NOTE** This option is unavailable if you enter an image file name with the syntax {slide\_library or dll file (slide or .png)}." For example, "S2(pb)" or "S7(control\_relay)". It is also unavailable if the Image File edit box contains the image file path instead of the image file name.

---

**Zoom**

(Available only when Create PNG from current screen image is selected.) Zooms in on the current screen image using AutoCAD Pan command. Once you exit Pan mode and press Enter, the dialog box redisplay so you can finish defining the new icon.

**Location**

(This option appears once the Image file is specified.) Indicates the full path of the image file location where the new images are created or the browsed images are copied to. If you entered a file name with

the syntax {slide\_library or dll file (slide or .png)} for the image file, the path of the .dat file or the WD\_SLB folder displays here.

### Command to Execute

---

**NOTE** If you select an AutoCAD Electrical command, manually enter the additional parameters as indicated.

---

<b>Command</b>	Specifies to start an AutoCAD command or AutoCAD Electrical routine. You can enter the command name to execute with arguments. Click List to select from a list of AutoCAD Electrical commands for panel, schematic multi-pole symbol, and one-line symbol inserts. It makes it easier for you to build the appropriate command to insert a symbol.
<b>Parameters</b>	Displays the command parameters for a specific AutoCAD Electrical command. If the command does not have any parameters, the value "none" displays.

## Create new circuit

The icon name and circuit drawing name are saved in the active \*.dat file (such as ACE\_JIC\_MENU.DAT) once you click OK on the Icon Menu Wizard dialog box. The icon then displays at the end of the existing icon images in the Symbol Preview window of the Insert Component dialog box.

 **Ribbon:** Schematic tab ► Other Tools panel ► Icon Menu Wizard.



 **Toolbar:** Miscellaneous

 **Menu:** Components ► Symbol Library ► Icon Menu Wizard

 **Command entry:** AEMENUWIZ

Select the menu file to modify and click OK. In the Icon Menu Wizard dialog box click Add, and then select New Circuit.

You can also access this dialog box by right-clicking in the Symbol Preview window of the Icon Menu Wizard dialog box and selecting Add Icon ► New Circuit.

---

**TIP** To determine which \*.dat file is active, in the Project Properties dialog box, Project Settings tab, Library, and Icon Menu Paths section, expand the Schematic Icon Menu File option. It is the schematic icon menu file listed in the \*.wdp file.

---

### Icon Details

Defines the icon name and image.

<b>Preview</b>	Displays an image preview of the specified image file.
<b>Name</b>	Specifies the name to appear in the icon, the description text, and the tool tip for the icon.
<b>Image file</b>	<p>Specifies the image file to use for the new icon. You can enter the image file name (or complete path) or select it using one of the following methods:</p> <ul style="list-style-type: none"><li>■ <b>Browse:</b> Finds an existing image to use for the icon. You can browse for .sld or .png images.</li><li>■ <b>Pick:</b> Selects an existing block name on the current drawing to use as the image file name. For example, if you select block HPB11, the image file name edit box displays "HPB11."</li><li>■ <b>Active:</b> (This method is unavailable if the drawing is a new drawing and has not been saved) Selects the active drawing name to use as the Image file. For example, if the active drawing name is "demo005," then the image file edit box has "demo005" listed as the file name.</li></ul>

The browsed image is copied to the User folder if wd\_userckt\_dir is disabled in the .env file.

---

**NOTE** The User folder can be overridden by the wd\_userckt\_dir defined folder if the environment code is enabled in the .env file.

---

Enclose the image path in quotation marks if you do not want the image copied to the User folder. Save the complete path instead of the relative path in the .dat file. The entered image file name can be names like "PB1" or "CONTROL RELAY," file names with an extension such as "pb1.png," or it can follow the syntax {slide\_library or dll file (slide or .png)}. For example, "S2(pb)" or "S7(control\_relay)."

---

**NOTE** The image file name cannot contain invalid characters such as \ / : " ? < > | and only .png and .sld image files are supported.

---

**Create PNG from current screen image**

Creates the .png image file from the current screen image. If the specified image file does not exist, this option is selected by default. If you do not want to create the icon from the displayed image of the current drawing, clear the check box.

---

**NOTE** This option is unavailable if you enter an image file name with the syntax {slide\_library or dll file (slide or .png)} For example, "S2(pb)" or "S7(control\_relay)". It is also unavailable if the Image File edit box contains the image file path instead of the image file name.

---

**Zoom**

(Available only when Create PNG from current screen image is selected) Zooms in on the current screen image using AutoCAD Zoom command. Once you exit Zoom mode and press Enter, the dialog box redisplay so you can finish defining the new icon.

**Location**

(This option appears once the Image file is specified) Indicates the full path of the image file location where the new images are created or the browsed images are copied to. If you entered a file name with the syntax {slide\_library or dll file (slide or .png)} for the image file, the path of the .dat file or the WD\_SLB folder displays here.

### **Circuit Drawing File**

Defines the circuit file name that is created.

**File Name**

Specifies the file name for the circuit. Enter a drawing file name to use.

**Location**

Displays the complete path of the new drawing file that is created. The default user circuit folder is the User folder if the wd\_usercktdir code is disabled in the environment file. If wd\_usercktdir is enabled, the folder defined by this code is used as the user circuit folder.

## **Add existing circuit**



The icon name and circuit drawing name are saved in the active \*.dat file (such as ACE\_JIC\_MENU.DAT) once you click OK on the Icon Menu Wizard dialog box. The icon then displays at the end of the existing icon images in the Symbol Preview window of the Insert Component dialog box.

 **Ribbon:** Schematic tab ► Other Tools panel ► Icon Menu Wizard.



 **Toolbar:** Miscellaneous

 **Menu:** Components ► Symbol Library ► Icon Menu Wizard

 **Command entry:** AEMENUWIZ

Select the menu file to modify and click OK. In the Icon Menu Wizard dialog box click Add, and then select Add Circuit.

You can also access this dialog box by right-clicking in the Symbol Preview window of the Icon Menu Wizard dialog box and selecting Add Icon ► Add Circuit.

---

**TIP** To determine which \*.dat file is active, in the Project Properties dialog box, Project Settings tab, Library, and Icon Menu Paths section, expand the Schematic Icon Menu File option. It is the schematic icon menu file listed in the \*.wdp file.

---

### Icon Details

Defines the icon name and image.

<b>Preview</b>	Displays an image preview of the specified image file.
<b>Name</b>	Specifies the name to appear in the icon, the description text, and the tool tip for the icon.
<b>Image file</b>	<p>Specifies the image file to use for the new icon. You can enter the image file name (or complete path) or select it using one of the following methods:</p> <ul style="list-style-type: none"> <li>■ Browse: Finds an existing image to use for the icon. You can browse for .sld or .png images.</li> <li>■ Pick: Selects an existing block name on the current drawing to use as the image file name. For example, if you select block HPB11, the image file name edit box displays "HPB11."</li> </ul>

- Active: (It is unavailable if the drawing is a new drawing and was not saved) Selects the active drawing name to use as the Image file. For example, if the active drawing name is "demo005," then the image file edit box has "demo005" listed as the file name.

If the circuit drawing file name contains the path of the drawing file referring to the User folder or the wd\_userckt\_dir defined folder, the browsed image is copied to the User folder if wd\_userckt\_dir is disabled in the .env file or the wd\_userckt\_dir defined folder if wd\_userckt\_dir is enabled in the .env file.

If the circuit drawing file name contains the path of the drawing file that does not refer to the User or wd\_userckt\_dir defined folder, the browsed image is copied to the Images folder and saved as a relative path in the .dat file. Enclose the image path in quotation marks if you do not want the image copied to the Images folder and to save the complete path instead of the relative path in the .dat file. The entered image file name can be names like "PB1" or "CONTROL RELAY," file names with an extension such as "pb1.png," or it can follow the syntax {slide\_library or dll file (slide or .png)}. For example, "S2(pb)" or "S7(control\_relay)."

---

**NOTE** The image file name cannot contain invalid characters such as \ / : " ? < > | and only .png and .sld image files are supported.

---

**Create PNG from current screen image**

Creates the .png image file from the current screen image. If the specified image file does not exist, this option is selected by default. If you do not want to create the icon from the displayed image of the current drawing, clear the check box.

---

**NOTE** This option is unavailable if you enter an image file name with the syntax {slide\_library or dll file (slide or .png)}" For example, "S2(pb)" or "S7(control\_relay)". It is also unavailable if the Image File edit box contains the image file path instead of the image file name.

---

**Zoom**

(Available only when Create PNG from current screen image is selected) Zooms in on the current screen image using AutoCAD Zoom command. Once you exit Zoom mode and press Enter, the dialog box redisplay so you can finish defining the new icon.

**Location**

(It appears once the Image file is specified) Indicates the full path of the image file location where the new images are created or the browsed images are copied to. If you entered a file name with the syntax {slide\_library or dll file (slide or .png)} for the image file, the path of the .dat file or the WD\_SLB folder displays here.

## Circuit Name to Insert

Defines the circuit to insert when you click the icon.

<b>File Name</b>	Specifies the file name for the circuit. Enter a drawing file name to use, click <b>Browse</b> to select a drawing, or click <b>Active</b> to use the active drawing name as the circuit name.
------------------	--

## Create new submenu

The icon name and submenu are saved in the active \*.dat file (such as ACE\_JIC\_MENU.DAT) once you click **OK** on the Icon Menu Wizard dialog box. The icon then displays at the end of the existing icon images in the Symbol Preview window of the Insert Component dialog box.

 **Ribbon:** Schematic tab ► Other Tools panel ► Icon Menu Wizard.



 **Toolbar:** Miscellaneous

 **Menu:** Components ► Symbol Library ► Icon Menu Wizard

 **Command entry:** AEMENUWIZ

Select the menu file to modify and click **OK**. In the Icon Menu Wizard dialog box click **Add**, and then select **New Submenu**.

You can also access this dialog box by right-clicking in the Symbol Preview window of the Icon Menu Wizard dialog box and selecting **New Sub Menu**.

---

**TIP** To determine which \*.dat file is active, in the Project Properties dialog box, Project Settings tab, Library, and Icon Menu Paths section, expand the Schematic Icon Menu File option. It is the schematic icon menu file listed in the \*.wdp file.

---

## Icon Details

Defines the icon name and image.

<b>Preview</b>	Displays an image preview of the specified image file.
<b>Name</b>	Specifies the name to appear in the icon, the description text, and the tool tip for the icon.

**Image file**

Specifies the image file to use for the new icon. You can enter the image file name (or complete path) or select it using one of the following methods:

- **Browse:** Finds an existing image to use for the icon. You can browse for .sld or .png images.
- **Pick:** Selects an existing block name on the current drawing to use as the image file name. For example, if you select block HPB11, the image file name edit box displays "HPB11."
- **Active:** (It is unavailable if the drawing is a new drawing and was not saved) Selects the active drawing name to use as the Image file. For example, if the active drawing name is "demo005," then the image file edit box has "demo005" listed as the file name.

The browsed image is copied to the Images folder and saved as a relative path in the .dat file. Enclose the image path in quotation marks if you do not want the image copied to the Images folder and to save the complete path instead of the relative path in the .dat file. The entered image file name can be names like "PB1" or "CONTROL RELAY," file names with an extension such as "pb1.png," or it can follow the syntax {slide\_library or dll file (slide or .png)}. For example, "S2(pb)" or "S7(control\_relay)."

---

**NOTE** The image file name cannot contain invalid characters such as \ / : " ? < > | and only .png and .sld image files are supported.

---

**Create PNG from current screen image**

Creates the .png image file from the current screen image. If the specified image file does not exist, this option is selected by default. If you do not want to create the icon from the displayed image of the current drawing, clear the check box.

---

**NOTE** This option is unavailable if you enter an image file name with the syntax {slide\_library or dll file (slide or .png)}." For example, "S2(pb)" or "S7(control\_relay)". It is also unavailable if the Image File edit box contains the image file path instead of the image file name.

---

**Zoom**

(Available only when Create PNG from current screen image is selected) Zooms in on the current screen image using AutoCAD Zoom command. Once you exit Zoom mode and press Enter, the dialog box redisplay so you can finish defining the new icon.

**Location**

(This option appears once the Image file is specified) Indicates the full path of the image file location where the new images are created or the browsed images are copied to. If you entered a file name with

the syntax {slide\_library or dll file (slide or .png)} for the image file, the path of the .dat file or the WD\_SLB folder displays here.

### Submenu

This section displays the menu number of the submenu page and allows you to define the submenu title.

<b>Menu Number</b>	Displays the menu number of the submenu page for reference.
<b>Menu Title</b>	Specifies the submenu title that is used in the Insert Component dialog box. It is automatically specified but you can edit the title. <hr/> <b>NOTE</b> The submenu icon name and the menu title can be different. For example, the icon name is Cable Markers but the submenu title is Special Cable Markers. <hr/>

### Properties - main menu

Use this tool to modify the existing menu properties such as changing the menu name. Your changes overwrite the information in the .dat file

 **Ribbon:** Schematic tab ► Other Tools panel ► Icon Menu Wizard.



 **Toolbar:** Miscellaneous



 **Menu:** Components ► Symbol Library ► Icon Menu Wizard

 **Command entry:** AEMENUWIZ

Select the menu file to modify and click OK. In the Icon Menu Wizard dialog box right-click the menu file to modify (for example, JIC Symbols) and select Properties.

<b>Name</b>	Specifies the name of the main menu. The default changes depending on which menu you are working with (for example, JIC Symbols).
<b>Menu File</b>	Displays the file name and full path of the menu file. (for example, ace_jic_menu.dat).

## Properties - component

Use this tool to modify the existing symbol icon properties such as changing the icon name, image, or block name. Your changes overwrite the information in the .dat file.

 **Ribbon:** Schematic tab ► Other Tools panel ► Icon Menu Wizard.



 **Toolbar:** Miscellaneous

 **Menu:** Components ► Symbol Library ► Icon Menu Wizard

 **Command entry:** AEMENUWIZ

Select the menu file to modify and click OK. In the Icon Menu Wizard dialog box right-click on the component icon to modify and select Properties.

---

**TIP** To determine which \*.dat file is active, in the Project Properties dialog box, Project Settings tab, Library, and Icon Menu Paths section, expand the Schematic Icon Menu File option. It is the schematic icon menu file listed in the \*.wdp file.

---

### Icon Details

Defines the icon name and image.

<b>Preview</b>	Displays an image preview of the specified image file.
<b>Name</b>	Specifies the name to appear in the icon, the description text, and the tool tip for the icon.
<b>Image file</b>	Specifies the image file to use for the new icon. You can enter the image file name (or complete path) or select it using one of the following methods: <ul style="list-style-type: none"><li>■ Browse: Finds an existing image to use for the icon. You can browse for .sld or .png images.</li><li>■ Pick: Selects an existing block name on the current drawing to use as the image file name. For example, if you select block HPB11, the image file name edit box displays "HPB11."</li></ul>

- **Active:** (This option is unavailable if the drawing is a new drawing and was not saved) Selects the active drawing name to use as the Image file. For example, if the active drawing name is "demo005," then the image file edit box has "demo005" listed as the file name.

The browsed image is copied to the Images folder and saved as a relative path in the .dat file. Enclose the image path in quotation marks if you do not want the image copied to the Images folder and to save the complete path instead of the relative path in the .dat file. The entered image file name can be names like "PB1" or "CONTROL RELAY," file names with an extension such as "pb1.png," or it can follow the syntax {slide\_library or dll file (slide or .png)}. For example, "S2(pb)" or "S7(control\_relay)."

---

**NOTE** The image file name cannot contain invalid characters such as \ / : " ? < > | and only .png and .sld image files are supported.

---

**Create PNG from current screen image**

(Available only when you edit the image file) Creates the .png image file from the current screen image. If the specified image file does not exist, this option is selected by default. If you do not want to create the icon from the displayed image of the current drawing, clear the check box.

---

**NOTE** This option is unavailable if you enter an image file name with the syntax {slide\_library or dll file (slide or .png)}." For example, "S2(pb)" or "S7(control\_relay)". It is also unavailable if the Image File edit box contains the image file path instead of the image file name.

---

**Zoom**

(Available only when Create PNG from current screen image is selected) Zooms in on the current screen image using AutoCAD Zoom command. Once you exit Zoom mode and press Enter, the dialog box re-displays so you can finish defining the new icon.

**Location**

(This option appears once the Image file is specified) Indicates the full path of the image file location where

the new images are created or the browsed images are copied to. If you entered a file name with the syntax {slide\_library or dll file (slide or .png)} for the image file, the path of the .dat file or the WD\_SLB folder displays here.

### Block Name to Insert

Defines the symbol block that is inserted when you click the icon in the Insert Component dialog box.

#### Block Name

Specifies the symbol block name. You can type the file name of the symbol into the edit box or you can enter it using one of the following methods:

- **Browse:** Finds an existing WBlocked drawing (\*.dwg) file to assign to the icon. In this case the complete path of the drawing file is inserted in the edit box.
- **Pick:** Selects an existing block on the current drawing (for example, block recently created with Symbol Builder). WBlocked version (.dwg) must exist.
- **Active:** Inserts the active drawing as a block.

### Properties - command

Use this tool to modify the existing icon properties such as changing the icon name, image, or command. Your changes overwrite the information in the .dat file.

 **Ribbon:** Schematic tab ► Other Tools panel ► Icon Menu Wizard.



 **Toolbar:** Miscellaneous

 **Menu:** Components ► Symbol Library ► Icon Menu Wizard

 **Command entry:** AEMENUWIZ

Select the menu file to modify and click OK. In the Icon Menu Wizard dialog box right-click on the command icon to modify and select Properties.



---

**TIP** To determine which \*.dat file is active, in the Project Properties dialog box, Project Settings tab, Library, and Icon Menu Paths section, expand the Schematic Icon Menu File option. It is the schematic icon menu file listed in the \*.wdp file.

---

### Icon Details

Defines the icon name and image.

<b>Preview</b>	Displays an image preview of the specified image file.
<b>Name</b>	Specifies the name to appear in the icon, the description text, and the tool tip for the icon.
<b>Image file</b>	<p>Specifies the image file to use for the new icon. You can enter the image file name (or complete path) or select it using one of the following methods:</p> <ul style="list-style-type: none"><li>■ <b>Browse:</b> Finds an existing image to use for the icon. You can browse for .sld or .png images.</li><li>■ <b>Pick:</b> Selects an existing block name on the current drawing to use as the image file name. For example, if you select block HPB11, the image file name edit box displays "HPB11."</li><li>■ <b>Active:</b> (This option is unavailable if the drawing is a new drawing and was not saved) Selects the active drawing name to use as the Image file. For example, if the active drawing name is "demo005," then the image file edit box has "demo005" listed as the file name.</li></ul> <p>The browsed image is copied to the Images folder and saved as a relative path in the .dat file. Enclose the image path in quotation marks if you do not want the image copied to the Images folder and to save the complete path instead of the relative path in the .dat file. The entered image file name can be names like "PB1" or "CONTROL RELAY," file names with an extension such as "pb1.png," or it can follow the syntax {slide_library or dll file (slide or .png)}. For example, "S2(pb)" or "S7(control_relay)."</p> <hr/> <p><b>NOTE</b> The image file name cannot contain invalid characters such as \ / : " ? &lt; &gt;   and only .png and .sld image files are supported.</p> <hr/>
<b>Create PNG from current screen image</b>	(Available only when you edit the image file) Creates the .png image file from the current screen image. If the specified image file does not exist, this option is selected by default. If you do not want to create

the icon from the displayed image of the current drawing, clear the check box.

---

**NOTE** This option is unavailable if you enter an image file name with the syntax {slide\_library or dll file (slide or .png)}" For example, "S2(pb)" or "S7(control\_relay)". It is also unavailable if the Image File edit box contains the image file path instead of the image file name.

---

<b>Zoom</b>	(Available only when Create PNG from current screen image is selected) Zooms in on the current screen image using AutoCAD Zoom command. Once you exit Zoom mode and press Enter, the dialog box redisplay so you can finish defining the new icon.
<b>Location</b>	(This option appears once the Image file is specified) Indicates the full path of the image file location where the new images are created or the browsed images are copied to. If you entered a file name with the syntax {slide_library or dll file (slide or .png)} for the image file, the path of the .dat file or the WD_SLB folder displays here.

### Command to Execute

Defines the command to execute when you click the icon.

---

**NOTE** If you select an AutoCAD Electrical command you must manually enter the additional parameters as indicated.

---

<b>Command</b>	Specifies to execute an AutoCAD command or AutoCAD Electrical routine. You can enter the command name to execute with arguments. Click List to select from a list of AutoCAD Electrical commands for panel and schematic multi-pole symbol inserts. It makes it easier for you to build the appropriate command to insert a symbol.
<b>Parameters</b>	Displays the command parameters for a specific AutoCAD Electrical command. If the command does not have any parameters, the value "none" displays.

### Properties - circuit

Use this tool to modify the existing icon properties such as changing the icon name, image, or circuit name. Your changes overwrite the information in the .dat file.

 **Ribbon:** Schematic tab ► Other Tools panel ► Icon Menu Wizard.



 **Toolbar:** Miscellaneous

 **Menu:** Components ► Symbol Library ► Icon Menu Wizard

 **Command entry:** AEMENUWIZ

Select the menu file to modify and click OK. In the Icon Menu Wizard dialog box right-click on the circuit icon to modify and select Properties.

---

**TIP** To determine which \*.dat file is active, in the Project Properties dialog box, Project Settings tab, Library, and Icon Menu Paths section, expand the Schematic Icon Menu File option. It is the schematic icon menu file listed in the \*.wdp file.

---

### Icon Details

Defines the icon name and image.

<b>Preview</b>	Displays an image preview of the specified image file.
<b>Name</b>	Specifies the name to appear in the icon, the description text, and the tool tip for the icon.
<b>Image file</b>	<p>Specifies the image file to use for the new icon. You can enter the image file name (or complete path) or select it using one of the following methods:</p> <ul style="list-style-type: none"><li>■ <b>Browse:</b> Finds an existing image to use for the icon. You can browse for .sld or .png images.</li><li>■ <b>Pick:</b> Selects an existing block name on the current drawing to use as the image file name. For example, if you select block HPB11, the image file name edit box displays "HPB11."</li><li>■ <b>Active:</b> (This option is unavailable if the drawing is a new drawing and was not saved) Selects the active drawing name to use as the Image file. For example, if the active drawing name is "demo005," then the image file edit box has "demo005" listed as the file name.</li></ul>

If the circuit drawing file name contains the path of the drawing file referring to the User folder or the wd\_userckt\_dir defined folder, the browsed image is copied to the User folder if wd\_userckt\_dir is disabled in the .env file or the wd\_userckt\_dir defined folder if wd\_userckt\_dir is enabled in the .env file. If the file does not exist, the Create Circuit alert dialog box displays asking you if you want to create the circuit.

If the circuit drawing file name contains the path of the drawing file that does not refer to the User or wd\_userckt\_dir defined folder, the browsed image is copied to the Images folder and saved as a relative path in the .dat file. Enclose the image path in quotation marks if you do not want the image copied to the Images folder and to save the complete path instead of the relative path in the .dat file. The entered image file name can be names like "PB1" or "CONTROL RELAY," file names with an extension such as "pb1.png," or it can follow the syntax {slide\_library or dll file (slide or .png)}. For example, "S2(pb)" or "S7(control\_relay)."

---

**NOTE** The image file name cannot contain invalid characters such as \ / : " ? < > | and only .png and .sld image files are supported.

---

**Create PNG from current screen image**

(Available only when you edit the image file) Creates the .png image file from the current screen image. If the specified image file does not exist, this option is selected by default. If you do not want to create the icon from the displayed image of the current drawing, clear the check box.

---

**NOTE** This option is unavailable if you enter an image file name with the syntax {slide\_library or dll file (slide or .png)} For example, "S2(pb)" or "S7(control\_relay)". It is also unavailable if the Image File edit box contains the image file path instead of the image file name.

---

**Zoom**

(Available only when Create PNG from current screen image is selected) Zooms in on the current screen image using AutoCAD Zoom command. Once you exit Zoom mode and press Enter, the dialog box redisplay so you can finish defining the new icon.

**Location**

(This option appears once the Image file is specified) Indicates the full path of the image file location where the new images are created or the browsed images are copied to. If you entered a file name with the syntax {slide\_library or dll file (slide or .png)} for the image file, the path of the .dat file or the WD\_SLB folder displays here.

**Circuit Name to Insert**

Defines the circuit file name that is created.

**File Name**

Specifies the complete path and file name of the new drawing file that is created. The default user circuit folder is the User folder if the wd\_usercktdir code is disabled in the environment file. If wd\_usercktdir is enabled, the folder defined by this code is used as the user circuit folder.

**Properties - submenu**

Use this tool to modify the existing icon properties such as changing the icon name, image, or submenu title. Your changes overwrite the information in the .dat file.

 **Ribbon:** Schematic tab ► Other Tools panel ► Icon Menu Wizard.



 **Toolbar:** Miscellaneous

 **Menu:** Components ► Symbol Library ► Icon Menu Wizard

 **Command entry:** AEMENUWIZ

Select the menu file to modify and click OK. In the Icon Menu Wizard dialog box right-click on the submenu to modify and select Properties.

---

**TIP** To determine which \*.dat file is active, in the Project Properties dialog box, Project Settings tab, Library, and Icon Menu Paths section, expand the Schematic Icon Menu File option. It is the schematic icon menu file listed in the \*.wdp file.

---

## Icon Details

Defines the icon name and image.

<b>Preview</b>	Displays an image preview of the specified image file.
<b>Name</b>	Specifies the name to appear in the icon, the description text, and the tool tip for the icon.
<b>Image file</b>	<p>Specifies the image file to use for the new icon. You can enter the image file name (or complete path) or select it using one of the following methods:</p> <ul style="list-style-type: none"><li>■ <b>Browse:</b> Finds an existing image to use for the icon. You can browse for .sld or .png images.</li><li>■ <b>Pick:</b> Selects an existing block name on the current drawing to use as the image file name. For example, if you select block HPB11, the image file name edit box displays "HPB11."</li><li>■ <b>Active:</b> (This option is unavailable if the drawing is a new drawing and was not saved) Selects the active drawing name to use as the Image file. For example, if the active drawing name is "demo005," then the image file edit box has "demo005" listed as the file name.</li></ul> <p>The browsed image is copied to the Images folder and saved as a relative path in the .dat file. Enclose the image path in quotation marks if you do not want the image copied to the Images folder and to save the complete path instead of the relative path in the .dat file. The entered image file name can be names like "PB1" or "CONTROL RELAY," file names with an extension such as "pb1.png," or it can follow the syntax {slide_library or dll file (slide or .png)}. For example, "S2(pb)" or "S7(control_relay)."</p> <hr/> <p><b>NOTE</b> The image file name cannot contain invalid characters such as \ / : " ? &lt; &gt;   and only .png and .sld image files are supported.</p>
<b>Create PNG from current screen image</b>	(Available only when you edit the image file) Creates the .png image file from the current screen image. If the specified image file does not exist, this option is selected by default. If you do not want to create the icon from the displayed image of the current drawing, clear the check box.

---

**NOTE** This option is unavailable if you enter an image file name with the syntax {slide\_library or dll file (slide or .png)}" For example, "S2(pb)" or "S7(control\_relay)". It is also unavailable if the Image File edit box contains the image file path instead of the image file name.

---

<b>Zoom</b>	(Available only when Create PNG from current screen image is selected) Zooms in on the current screen image using AutoCAD Pan command. Once you exit Pan mode and press Enter, the dialog box redisplay so you can finish defining the new icon.
<b>Location</b>	(This option appears once the Image file is specified) Indicates the full path of the image file location where the new images are created or the browsed images are copied to. If you entered a file name with the syntax {slide_library or dll file (slide or .png)} for the image file, the path of the .dat file or the WD_SLB folder displays here.

### Submenu

This section displays the menu number of the submenu page and allows you to define the submenu title.

<b>Menu Number</b>	Displays the menu number of the submenu page for reference.
<b>Menu Title</b>	Specifies the submenu title that is used in the Insert Component dialog box. It is automatically specified but you can edit the title if desired.

---

**NOTE** The submenu icon name and the menu title can be different. For example, the icon name is Cable Markers but the submenu title is Special Cable Markers.

---

## Use alternate icon menus

AutoCAD Electrical defaults to icon menu ACE\_<standard>\_MENU.DAT (where <standard>= JIC, IEC, AS, GB, HYD, JIS, PID, or PNEU) for schematic symbols and ACE\_PANEL\_MENU.DAT for panel symbols. These menu files are found in:

- **Windows XP:** C:\Documents and Settings\{username}\Application Data\Autodesk\AutoCADElectrical {version}\{release}\{country code}\Support\

■ **Windows Vista, Windows 7:**

C:\Users\{username}\AppData\Roaming\Autodesk\AutoCADElectrical  
{version}\{release}\{country code}\Support\

You can create alternate or project-specific icon menus and have AutoCAD Electrical automatically use them instead of these defaults.

An icon menu can be tied to a project so that when the project is active, AutoCAD Electrical references that special icon menu instead of the AutoCAD Electrical normal menu. The full path of the alternate menu and file name is saved in the project's .wdp file. You can save an alternate menu for schematic symbols and one for panel symbols.

**Assign specific icon menu files to a project**



- 1 Click Project tab ► Project Tools panel ► Manager.
- 2 Make sure that the project is the active project, right-click on the project name, and select Properties.
- 3 In the Project Properties ► Project Settings dialog box, click the plus sign (+) next to Schematic Icon Menu File or Panel Icon Menu File. Click inside the edit box to change the path of the icon menu, click Browse to search for and select an icon menu, or click Default to use the default icon menu.
- 4 Click OK.

---

**NOTE** If you make custom images or libraries for the menu, copy them to the same subdirectory as the menu file since AutoCAD Electrical looks for menu images in the directory of the active menu file.

---

## Modify Icon Menu File Directly

### Overview of the icon menu file

AutoCAD Electrical supplies several default icon (.dat) menus for schematic symbols and one for panel symbols. For example, the JIC schematic icon menu



is defined by the contents of file ACE\_JIC\_MENU.DAT file and the panel menu is ACE\_PANEL\_MENU.DAT. These menu files are found in:

- **Windows XP:** \Documents and Settings\{username}\Application Data\Autodesk\AutoCAD Electrical {version}\{release}\{country code}\Support\
  - **Windows Vista, Windows 7:**  
\Users\{username}\AppData\Roaming\Autodesk\AutoCAD Electrical {version}\{release}\{country code}\Support\

The other icon menu files include: ACE\_AS\_MENU, ACE\_GB\_MENU, ACE\_JIS\_MENU, ACE\_IEC\_MENU, ACE\_HYD\_MENU, ACE\_PID\_MENU, ACE\_PNEU\_MENU and WD\_ABECAD.

There may be times when you want to bypass the Icon Menu Wizard and edit the .dat text file directly using any text editor (such as Microsoft Notepad). It is important to maintain the menu file structure, otherwise your menu may not activate properly.

Here are the first few lines of the first page and a submenu (JIC: Push Buttons) of the ACE\_JIC\_MENU.DAT file. Refer to it in the following sections.

```
**M0
D0
JIC: Schematic Symbols
Push Buttons ls2(s_pb)|$S=M3
Selector Switches ls2(s_ss)|$S=M6
Limit Switches ls2(s_zs)|$S=M8
**M3
D5W
JIC: Push Buttons
Push Button NO ls2(shpB11)|HPB11
Push Button NC ls2(shpB12)|HPB12
```

---

**NOTE** You can have an unlimited number of icons on each menu page. Before AutoCAD Electrical 2008, you were limited to 24 icons per page.

---

### Page structure of the icon menu

Each menu page starts with a menu number line preceded by two asterisks (\*\*). The next line is an AutoCAD Electrical code, which defines the menu page format (such as how many rows, how many icon buttons per row). It is used for .dat files that are used before AutoCAD Electrical 2008. The next line is the title, with optional column labels, for the menu page. The rest of the lines define the information for each icon button on the menu page. These icons can either launch a command, insert a component or open a submenu.

<b>**M0</b>	Menu number
<b>JIC Symbols</b>	Main menu title. In the Insert Component dialog box, it is the main menu title in the Menu tree selection view and is also displayed above the Symbol Preview window of the dialog box.
<b>Push Buttons</b>	Description text of the icon. It is also the tooltip for the submenu page, command, or component to insert. In this example, clicking Push Buttons in the Insert Component dialog box opens a submenu.
<b>s2(s_pb)</b>	Image information with the syntax: slide_library_name(slide or .png). In this example, the slide library (or resource dll library) is "s2" and the slide file (or .png image) is "s_pb." <hr/> <b>NOTE</b> If both s_pb.png and s_pb.sld exist, AutoCAD Electrical searches for the .png file first. If not found, looks for the s_pb.sld file. <hr/>
<b>\$\$=M3</b>	Submenu trigger. The syntax is: \$\$=menu number. In this example, menu 3 is used for push buttons. It is used to develop the Menu tree structure in the Insert Component dialog box.

### Icon function - submenu trigger

<b>**M3</b>	Submenu number
<b>D5W</b>	(Used for .dat files before AutoCAD Electrical 2008) Indicates the number of rows in the menu. In AutoCAD Electrical 2008, you can have any number of rows or columns in your menu. This value is only

used to structure .dat files in older versions of AutoCAD Electrical.

#### JIC: Push Buttons

Submenu page title. This displays below the main menu (JIC Symbols) in the Menu tree structure view of the Insert Component dialog box.

#### Add submenu pages

Enter the definition for any new submenu pages at the bottom of the .dat file. A new Special Symbols submenu page added using the Icon Menu Wizard adds the following lines of text:

**\*\*M101**

**SPECIALSYMBOLS**

Explanation:

**\*\*M101**

Menu page number. User-created menu pages should begin at 100 since AutoCAD Electrical uses 1-99 for its own use.

**SPECIALSYMBOLS**

Menu page title

#### Icon function - insert component

**Push Button N.O.**

Description text of the icon. It is also the tool tip for the component to insert. In this example, clicking Push Button N.O. in the Insert Component dialog box inserts the component in the drawing.

**s2(shpB11)**

Image information with the syntax: slide\_library\_name(slide or .png). In this example, the slide library (or resource dll library) is "s2" and the slide file (or .png image) is "shpB11."

**HPB11**

Specifies the block name. The block name is searched in the symbol library search path as defined by the Project Properties dialog box and is inserted into the drawing.

Each entry consists of three parts separated by "|" characters. The first part is the text that is displayed in the Menu tree structure view or as a tool tip in

the Symbol Preview window. The second part is the slide (or .png) name. Include the path to the .SLD. If the slide is contained within a slide library (or resource dll library) the format here is library\_name (slide\_name). The third part is the actual icon function. The function can be a symbol name to insert, a submenu trigger, or a command. A line that looks like this can be added by the menu wizard to insert a special switch:

Special Switch | hzs11.sld| HZS11

### Icon function - execute command

Clicking on an icon in the icon menu can also execute an AutoCAD Electrical command. The following example shows the syntax for commands:

3 Pole Disconnect |s1(shds13)|\$c=wd\_3unit HDS11

**3 Pole Disconnect**

Description text of the icon. It is also the tool tip for the command. In this example, clicking 3 Pole Disconnect in the Insert Component dialog box runs a command.

**s1(shds13)**

Image information with the syntax: slide\_library\_name(slide or .png). In this example, the slide library (or resource dll library) is "s1" and the slide file (or .png image) is "shds13."

**\$C=wd\_3unit**

Code that executes a command. The syntax is: \$C=command name {command parameters}. In this example, the command wd\_3unit is run when the icon is clicked.

**HDS11**

Specifies the command parameters.

## Catalog database

Sample catalog information is furnished with the default AutoCAD Electrical installation. The information is held in tables in a Microsoft Access database file (.mdb) which are populated with sample vendor data. Expand and modify these tables to meet your specific BOM reporting needs. Use tools provided with AutoCAD Electrical, or use a database program that can read/write the Access file format.

The .mdb file is a single file that is named <project>\_cat.mdb or default\_cat.mdb. If the project-specific.mdb file is used, it must be in the same subdirectory as the <project>.wdp file is located. Here is the AutoCAD Electrical search sequence:

- First choice -- <project>\_cat.mdb (in project's subdirectory of the project)
- Second choice -- default\_cat.mdb (in subdirectory of the project)
- Third choice -- default\_cat.mdb (in user subdirectory)
- Fourth choice -- default\_cat.mdb (in subdirectory of the catalog)

Catalog information can be carried on parent or stand-alone components that have MANUFACTURER, CATALOG, and optional ASSEMBLYCODE attributes. You can assign catalog information to the attributes of a component at component insertion time or any time later during an edit of the component.

### Catalog table naming conventions

Each primary or stand-alone component type can have an associated table in your Access mdb file. This approach is taken for both performance reasons and to exclude invalid choices. For example, you cannot assign a blue press-test pilot part number to a standard red pilot light symbol. There can be multiple

catalog tables for the same component family. Alternately, all master test and all neon pilot lights (of all colors) can be combined into a single catalog table named LT. AutoCAD Electrical determines the default catalog lookup table name based on the WDBLKNAM attribute.

The following example references a custom master control relay with block name "HCR1\_MC\_PWR."

**If your symbol does not carry the WDBLKNAM attribute:**

- 1 The symbol is checked for the WDBLKNAM attribute (or Xdata). It is not found.
- 2 The block name is read ("HCR1\_MC\_PWR") minus its first character (the orientation character "H" or "V"). The default\_cat.mdb file is searched for a table named "CR1\_MC\_PWR."
- 3 If this table exists, it is used. If this table does not exist, and the block name is eight characters or more, AutoCAD Electrical starts removing characters from the block name, looking for a table name match with each character removed. This process continues until only seven characters remain. Table names that it would look for in sequence would be "CR1\_MC\_PW", "CR1\_MC\_P", "CR1\_MC\_."
- 4 If there is not a match on the last table name, AutoCAD Electrical checks for the family-specific table (CR). It is the second and third character of the block name.
- 5 If this table exists, it is used. If it does not exist, a MISC\_CAT table is looked for if the active properties of the project are set up to use this catch-all table.
- 6 If all these items fail, AutoCAD Electrical stops looking (if running a report) or prompts you to add a table to the default\_cat.mdb file (if you are inserting or editing a component).

**If your symbol includes the invisible WDBLKNAM attribute with a value of "HCRM":**

- 1 The symbol is checked for the WDBLKNAM attribute (or Xdata). It is found. The attribute value of "HCRM" is used instead of the block name and proceeds to step 2.
- 2 The leading "H" or "V" character is removed. The default\_cat.mdb file searches for a table named "CRM."
- 3 If this table exists, it is used. If the table does not exist, and the attribute value is eight characters or more, AutoCAD Electrical starts removing

characters from the attribute value, looking for a table name match with each character removed. This process continues until only seven characters remain. In this case, characters are not removed.

- 4 If there is not a match on the last table name, AutoCAD Electrical checks for a family-specific table (CR). It is the second and third character of the original WDBLKNAM value (HCRM).
- 5 If this table exists, it is used. If it does not exist, a MISC\_CAT table is looked for if the properties of the active project are set up to use this catch-all table.
- 6 If all these items fail, AutoCAD Electrical stops looking (if running a report) or prompts you to add a table to the default\_cat.mdb file (if you are inserting or editing a component).

If you want your custom symbol to go to table “CRM” in the catalog database file instead of the existing table “CR” you must:

- 1 Add the WDBLKNAM attribute to your master control relay coil library symbols with a value of “HCRM” or “VCRM” (the orientation does not matter).

Manually add the CRM table in your catalog lookup database file.

- 2 Click Project tab > Other Tools panel >  > Add Table to Catalog



---

**NOTE** AutoCAD Electrical always goes to the fixed table names for PLC I/O modules (PLCIO), terminals (TRMS) and cable markers (W0). Panel layout symbols must always use the WDBLKNAM attribute or Xdata without the leading H or V character.

---

### Family tables in the default\_cat.mdb

The list of tables available in the default\_cat.mdb is shown in the following table. All tables are family-specific and one table is created for each family.

Family Code/Table Name	Description
_FAMILY_DESCRIPTION	Table used by Symbol Builder to map the attribute template type to a symbol type description. The description is displayed in the Type

Family Code/Table Name	Description
	list on the <a href="#">Select Symbol / Objects</a> on page 342 dialog box. See <a href="#">Create a Symbol Builder attribute template</a> on page 2105.
_LISTBOX_DEF	Allows starting MFG/TYPE/RATING combinations to be predefined for each catalog lookup table, when AutoCAD Electrical would normally default to the values given in the first record of the selected catalog lookup table. See <a href="#">Overview of the LISTBOX_DEF catalog database table</a> on page 1277.
_PINLIST	Default pin list data table. AutoCAD Electrical also contains manufacturer-specific pin list tables that have the same format as the _PINLIST table. The naming convention for manufacturer-specific tables is: _PINLIST_AB or _PINLIST_AROMAT. AutoCAD Electrical first searches manufacturer-specific tables; if not found, it then searches the default _PINLIST table. See <a href="#">Use pin lists</a> on page 1304.
_TERMPROPS	Default terminal properties data table. AutoCAD Electrical also contains manufacturer-specific terminal properties tables that have the same format as the _TERMPROPS table. The naming convention for manufacturer-specific tables is: _TERMPROPS_AB or _TERMPROPS_AROMAT. AutoCAD Electrical first searches manufacturer-specific tables; if not found, it then searches the default _TERMPROPS table. See <a href="#">Edit terminal properties database</a> on page 1060.
_W0_CBLWIRES	Cable conductors. See <a href="#">Edit the cable conductor database</a> on page 953.
_XREF_GRAPHICS	Table cross-reference style symbol mapping table. Maps a contact block name to a graphic drawing name. This graphic drawing is inserted as a block in the TYPE column of the cross-reference table for the contact. See <a href="#">Edit cross-reference symbol mapping table</a> on page 830.
AM	Ammeters
AN	Buzzers, horns, bells
CB	Circuit breakers
C0	Connectors/pins



<b>Family Code/Table Name</b>	<b>Description</b>
CR	Control relays
DI	Din Rail
DN	Device networks
DO	Diodes
DR	Drives
DS	Disconnect switches
EN	Enclosures/hardware
FM	Frequency meters
FS	Flow sensors
FT	Foot switches
FU	Fuses
LR	Latching relays
LS	Limit switches
LT	Lights, pilot lights
MISC	Miscellaneous
MO	Motors
MS	Motor starters/contactors
NP	Nameplates
OL	Overloads
PB	Push buttons
PE	Photo switches

<b>Family Code/Table Name</b>	<b>Description</b>
PLCIO	Programmable logic controllers
PM	Power meters
PNEU-ACT	Actuators
PNEU-ALU	Lubricators
PNEU-CYL	Cylinders
PNEU-FLC	Flow Control
PNEU-FLT	Filters
PNEU-MET	Pressure Gauges
PNEU-MFL	Silencers
PNEU-MNF	Manifolds
PNEU-MOT	Motors
PNEU-NOZ	Nozzles
PNEU-OPR	Push buttons
PNEU-PMP	Pumps
PNEU-TNK	Reservoirs
PNEU-VAC	Suction
PNEU-VLV	Valves
PS	Pressure switches
PW	Power supplies
PX	Proximity switches
RE	Resistors

Family Code/Table Name	Description
SS	Selector switches
SU	Surge suppressors
SW	Toggle switches
TD	Timer relays
TRMS	Terminal blocks
TS	Temperature switches
VM	Volt meters
WO	Cables, multi-conductor cables
WW	Wire ways
XF	Transformers

## Move the catalog database file

In Project Manager, right-click the project name and select Settings to find the location of the default\_cat.mdb file. If you want to move this file to another directory, such as a shared network drive, then edit a small text file to tell AutoCAD Electrical where to look.

- 1 Move the file to your new drive:directory.
- 2 Exit AutoCAD. Edit the .env file with a text editor like WordPad or Notepad. Use the Settings option on the Project Manager to find the full path.
- 3 Find the WD\_CAT entry. Change the line to point to the new location for the catalog file. For example, you move them to n:/electric/catalogs/ on your network drive. Change this line to:  
WD\_CAT,n:/electric/catalogs/,AutoCAD Electrical catalog file.
- 4 Save and exit the file.

---

**NOTE** AutoCAD Electrical looks for a project-specific MDB file first, called <project>\_cat.mdb, in the subdirectory of the project.

---

## Define a secondary catalog lookup file for a project

You can use two catalog database files when working with an AutoCAD Electrical project: the first file can contain the catalog information that you commonly use, and the second file can contain the full list of catalog content available with AutoCAD Electrical.

- 1 Copy the default\_cat.mdb file and save it with a different name (such as full\_catalog.mdb).
- 2 Modify the original default\_cat.mdb file to contain only the catalog information that you commonly use. Save this file as default\_cat.mdb.
- 3 In AutoCAD Electrical, right-click on the project name in the Project Manager and select Properties.
- 4 On the Project Properties ► Project Settings dialog box, Catalog Lookup File Preference section, click Other File.
- 5 On the Catalog Lookup File dialog box, select Optional: Define a secondary catalog lookup file for this project.
- 6 Browse to and select the file you created in step 1 (full\_catalog.mdb) and click Open.

For each project you set up this file for, you only see the content from your default\_cat.mdb file in the Parts Catalog dialog box. For catalog information that is in the full catalog database file (full\_catalog.mdb), click Secondary File on the Database drop-down on the Parts Catalog dialog box. The Parts Catalog dialog box temporarily switches to the secondary catalog lookup file.

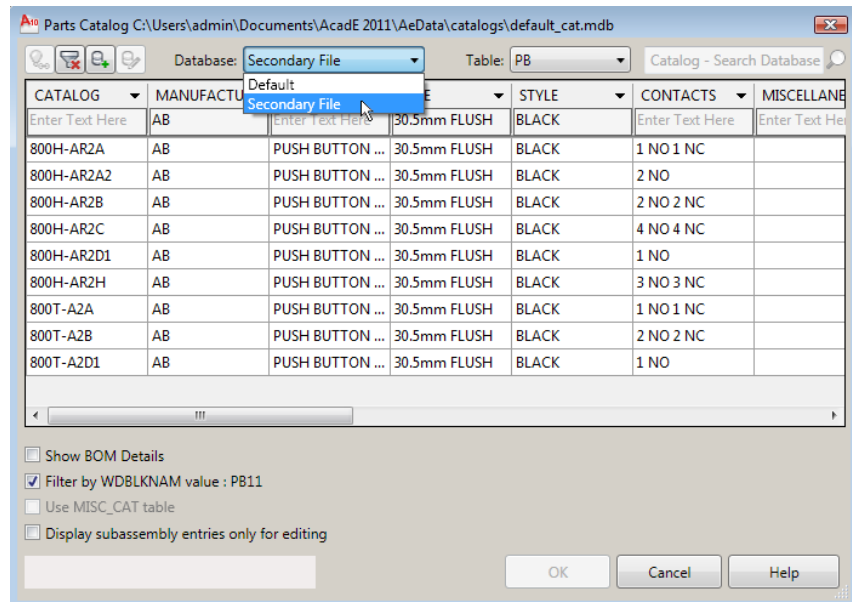

## How to install additional manufacturer content

During installation, you specified which manufacturer content to install. You can install additional manufacturer content later.

- 1 Close all instances of AutoCAD Electrical.
- 2 From the Windows Control Panel select Add or Remove Programs.
- 3 From the Add or Remove Programs dialog box, select the latest version of AutoCAD Electrical and click the Change/Remove button.
- 4 On the AutoCAD Electrical Installation Wizard, click Add or Remove Features.
- 5 On the Add/Remove Features page, click Next.
- 6 On the Manufacturer Content Selection page, select all the manufacturers you wish to install. Click Next.
- 7 On the Select Symbol Libraries page, click Next.
- 8 Click Next to continue.

## Overview of the catalog database table structure

AutoCAD Electrical uses the first 16 fields for its own which includes three user fields for your use. You can insert additional fields beyond the 16th one, but they are ignored when generating reports. Here are the 16 fields accessed by AutoCAD Electrical. (They must remain in this order in the database records.)

Field Name	Width	Description
CATALOG	60	Catalog number.
MANUFACTURER	24	Manufacturer code; abbreviations are allowed.
DESCRIPTION	150	Generic description.
TYPE	100	Generic type (field name varies based on table name).
RATING	100	Generic rating (field name varies based on table name).
MISCELLANEOUS1	100	First miscellaneous text field (header cell is based on the component family).
MISCELLANEOUS2	100	Second miscellaneous text field (header cell is based on the component family).
ASSEMBLYCODE	60	Code to flag that this item has subassembly items. Use a unique name code to link this main catalog item with other subassembly items. Spaces are allowed.
ASSEMBLYLIST	24	Code to flag as a subassembly item of a main item.
ASSEMBLYQUANTITY	8	Subassembly quantity (blank = quantity of 1).
USER1	100	Field #1 for other information.
USER2	100	Field #2 for other information.
USER3	100	Field #3 for other information.

Field Name	Width	Description
TEXTVALUES	255	Optional user-defined RATING/miscellaneous attribute values.
WEBLINK	255	Associate .pdf files or Web URL to component.
WDBLKNAM	60	AutoCAD Electrical block name minus the first character of the block name since the first character is the orientation of block (H= Horizontal, V= Vertical).

### TEXTVALUES rating and miscellaneous attribute value assignment

An optional 14th field named TEXTVALUES can be added to any catalog lookup table. This field can be used to vector text values to specific attributes on the edited component. The format for the text data encoded into this field is:

```
<attribute tag name1>=<text value>;<attribute tag name2>=<text value>
```

For example, a current catalog entry must annotate the component block attributes RATING1 and RATING2 with "ON DELAY" and "5-30 sec" respectively. Insert the following text string into the TEXTVALUES edit box:

```
RATING1=ON DELAY;RATING2=5-30 sec
```

---

**TIP** Rating attributes that are common among all component types make the population of the catalog database easier.

---

When inserting or editing components, if you make a catalog selection that comes with a non-blank TEXTVALUES, AutoCAD Electrical breaks apart the field value and searches for the target attributes on the edited symbol. If found, the target attributes of the component are updated with the encoded data pulled from the user-selected catalog lookup record. To use this value:

- 1 Add this field to any catalog database table if it does not exist.
- 2 Trigger AutoCAD Electrical to display the target catalog lookup table. (Insert a component and then select Catalog Lookup on the Insert/Edit Component dialog box.)
- 3 On the Parts Catalog dialog box, pick the appropriate part number and click Edit Catalog Entry.

- 4 On the Edit Record dialog box, type a value into the TEXTVALUES edit box and click OK.

If the TEXTVALUES field did not exist in the selected catalog table, it is added to each record in the database. If it did exist, your new value is saved in the TEXTVALUES field for the selected record of the catalog number.

### **WEBLINK assignment**

Sometimes, you want to see more information about your component than can be held in the catalog database. For example, suppose you want to see a picture of the item or get its specifications. Use the 15th field in the catalog database to set up the WEBLINK to achieve the result you need. If the WEBLINK field for the selected part is a Web URL, your Internet browser launches and displays it. If it is an image file, PDF, spreadsheet, or some other document type, the application associated with that file extension (for example, "Open With...") starts and displays the contents of the file.

---

**NOTE** For PDF display, you can include the page number to display upon document open. Add a space and the page number after the PDF file name in the WEBLINK field value (for example, C:\rockwell\700series.pdf 13). It does not work for PDF files loaded across the Web.

---

If the View Web Link button on the Parts Catalog dialog box is disabled, the catalog lookup record does not have a WEBLINK field defined as the 15th field. To add this field, select the Edit Catalog Entry button on the Parts Catalog dialog box.

A Weblink assignment can show up in the Surf dialog box. If you select a parent component to surf on, and it carries a catalog assignment that references a Weblink value, it displays in the surf selection dialog box along with the other related component references. Double-clicking the Weblink reference launches your browser or appropriate application.

---

**NOTE** Picking on a child component to initialize in the Surf dialog box does not display a Weblink referenced by a related parent. Pick the parent carrying the catalog assignment.

---

### **WDBLKNAM assignment**

The WDBLKNAM value filters the symbol names that display in the Parts catalog dialog box. The Filter by WDBLKNAM value option on the Parts Catalog dialog box suppresses what data displays when a catalog lookup is run for a particular component. If you perform a catalog lookup on a symbol with block



name “HTD1\_xxx” and the Filter by WDBLKNAME value option is selected, the only records that display are listed in the TD table of the catalog database file that have a blank WDBLKNAME value or a value in the WDBLKNAME field that matches the block name of the symbol. For example, a catalog lookup on an on-delay coil (HTD1N.dwg or VTD1N.dwg) displays all blank WDBLKNAME entries and all entries that include “TD1N” somewhere in the WDBLKNAME field. If this option is not selected, the query ignores the check on the WDBLKNAME field and returns all catalog information.

You can do one of the following to determine how your catalog content is filtered:

- 1 Add your block name to all WDBLKNAME fields in the catalog table. Using the example above, you would add the block name to the TD table.
- 2 Add an invisible WDBLKNAME attribute to your symbol. Using the previous example, name your symbol “HTD1F” for an off-delay coil or “HTD1N” for an on-delay coil.
- 3 Rename your block with the appropriate prefix (for example, “VTD1F”) followed by a substring “\$\$” and any other suffix to make the block name unique. The catalog lookup in AutoCAD Electrical sees the “\$\$” and assumes that it, and anything after it, is ignored. It treats your symbol as if the block name were just the basic name of “VTD1F.”

---

**TIP** Option 2 or 3 is preferred.

---

## Overview of the `_LISTBOX_DEF` catalog database table

This optional table can be included in the catalog database file. It allows you to predefine filtering of the catalog entries on the Parts Catalog dialog box. AutoCAD Electrical normally shows all the entries for the selected catalog lookup table.

Filtering values can be defined differently for each catalog lookup table. The first field defines the catalog lookup table name. The next fields follow the same format and order as the [catalog lookup table structure](#) on page 1274. Leave the field blank if you do not want to filter the records based on the values in that field. Access automatically handles the last field, which is the record number.

- 1 When the Parts Catalog dialog box displays, the program checks to see if the component already has a catalog defined.
- 2 If no catalog is defined, the program checks the \_LISTBOX\_DEF table for a record with a TABLENAME value that matches the [table name](#) on page 1265 for the component.
- 3 If a TABLENAME match is found, the program filters the records displayed in the Parts Catalog dialog box using the non-blank values from the \_LISTBOX\_DEF record.

For example, when you first insert a relay coil symbol and open the Parts Catalog dialog box, you want the "CR" catalog table display to default to Allen-Bradley part numbers for "TYPE P" relays. Use a copy of Microsoft Access to open the catalog lookup file, and select table \_LISTBOX\_DEF. Insert a record with these field values: TABLENAME "CR", MANUFACTURER "AB", and TYPE "TYPE P". The text you enter must exactly match existing field values in the target table. Save and exit. Now, when you insert a relay coil and select Catalog Lookup, the dialog box opens with these filters predefined.

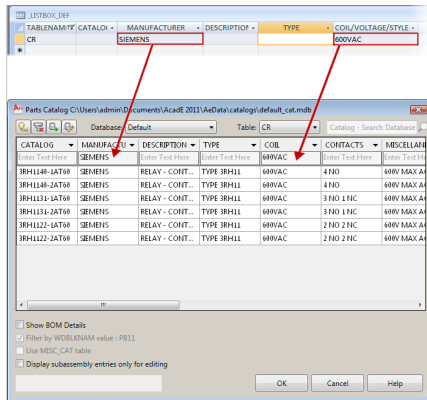

**NOTE** The column names in the \_LISTBOX\_DEF table do not affect the functionality.

### Terminals

Terminals always default to the TRMS table in the catalog lookup. However, the \_LISTBOX\_DEF table supports 2 special TABLENAME values for terminals

to make it easier when assigning a catalog to a terminal accessory or terminal jumper.

- **TRMS(H)** - defines the filters when adding terminal accessories from Terminal Strip Editor.  
For example: TABLENAME=TRMS(H), MANUFACTURER = AB, TYPE = HARDWARE
- **TRMS(J)** - defines the filters when adding terminal jumpers from Terminal Strip Editor or the Edit Jumper command.  
For example: TABLENAME=TRMS(H), MANUFACTURER = AB, TYPE = HARDWARE, RATING = JUMPER.

## Create a project-specific catalog database

Sample catalog information is furnished with the default AutoCAD Electrical installation. The information is held in tables in a Microsoft Access Database file (.mdb) which are populated with sample vendor data. This database can potentially hold hundreds of thousands of entries. Your project likely uses a small percentage of these entries. You can create a project-specific catalog database containing only the entries used in your project.

- Send a copy of this smaller catalog database to your client with the finished project.
- Limit catalog selection to components already used in the project.

### Creating a project-specific catalog database

Creates a catalog database of items used in the active project.

- 1 Click Project tab ➤ Other Tools panel ➤  ➤ Create



Project-specific Catalog Database.

- 2 Confirm the catalog database name. If necessary, enter or browse to a different catalog file name.
- 3 If a [secondary catalog file](#) on page 1272 is defined in the project properties, the name is shown in the Secondary catalog file edit box. This file name cannot be changed.

- 4 Select whether to save the catalog file to the project folder with the file name {project name}\_cat.mdb.
  - Yes** - the file becomes the new project catalog lookup file.
  - No** - the project does not reference the file. Define the database file name and folder.
- 5 Click OK.

The specified catalog database file is copied to the new name. Entries that are not used in the project are removed from the new file. All reference tables with names that begin with an underscore ( \_ ) are copied intact to the new file.

## Create Project-Specific Catalog Lookup File

Creates a catalog database of items used in the active project.

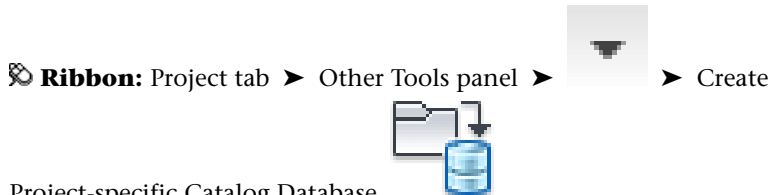

Project-specific Catalog Database.

**Command entry:** AECREATEPROJCATALOG

The specified catalog database file is copied to the new name. Entries that are not used in the project are removed from the new file. All reference tables with names that begin with an underscore ( \_ ) are copied intact to the new file.

<b>Main catalog file</b>	Displays the main catalog file assigned to the active project. If the active project is already using a project-specific catalog file, the program displays the default_cat.mdb file.
<b>Secondary catalog file</b>	If there is a <a href="#">secondary catalog lookup</a> on page 1272 defined, displays the name. The secondary catalog file name cannot be changed. <hr/> <b>NOTE</b> If no secondary catalog file is defined for the project, this control is disabled. <hr/>
<b>Save in project folder</b>	<b>Yes</b> - automatically create the project-specific catalog file in the same folder as the WDP file for the active project. The file name is pre-defined as {project name}_cat.mdb.

**No** - enables the new project-specific file edit box and browse button. Enter or browse to the file name and folder. The file name is pre-defined as {project name}\_cat.mdb but stored in the user folder defined in the WD\_USER entry of the wd.env file.

**Location**

Displays the file path for the project specific-catalog file.

## Catalog Assignment

### Assign catalog information to components

Vendor catalog parts lookup and assignment is crucial to enabling AutoCAD Electrical to create various detailed BOM reports automatically. It is also a key step in the workflow between control schematic wiring diagrams and derived physical panel layouts. Catalog parts lookup is through a multitable Microsoft Access database file (default\_cat.mdb) shipped with AutoCAD Electrical. It is populated with some commonly used component part numbers and descriptions from some of the major electrical controls vendors. The database content is found at:

- **Windows XP:** C:\Documents and Settings\{username}\My Documents\Acade {version}\AeData\Catalogs\
- **Windows Vista, Windows 7:** C:\Users\{username}\Documents\Acade {version}\AeData\Catalogs\

Catalog information is carried on a parent or stand-alone component. You can define exactly where AutoCAD Electrical looks for this catalog information, allowing great flexibility in how you keep your catalog information. There are some ways to assign your catalog information to a component:

#### **Use the Component Insert/Edit dialog box**

The AutoCAD Electrical Insert/Edit dialog box appears when you insert a new component or edit one. Click Lookup to view the catalog database file of the component. It is where you can search the database for a specific catalog item to assign to the selected component.

### **Use a project-specific catalog file**

You can set up a project catalog file with all the component types of the project in it. The file must reside in the subdirectory of the project. Name the file either `default_cat.mdb` or `<project>_cat.mdb`. AutoCAD Electrical references this file first before looking in the user subdirectory or the catalogs subdirectory (as defined in `wd.env`).

### **Use a miscellaneous catalog file**

You can set up a general catalog table within the `.mdb` file with all component types in it. AutoCAD Electrical references this table, if it exists. The table name is `MISC_CAT`. If found, this catalog information displays in the dialog box for component catalog number selection. In the Insert/Edit dialog box, Catalog Data section, click Lookup. In the Parts Catalog dialog box, click Miscellaneous.

### **Use the last used assignment**

During your editing session, AutoCAD Electrical remembers the last MFG / CAT / ASSYCODE assignment you make for each component inserted into your wiring diagram. When you insert another component of that type, AutoCAD Electrical presents the previous catalog assignment of the component as the default. This assumes that a previous catalog assignment was made during the current editing session.

### **Perform a drawing or project-wide search**

In the Insert/Edit dialog box, Catalog Data section, click Project to instruct AutoCAD Electrical to create a drawing-wide or project-wide listing of similar components with their catalog assignments.

### **Pull information from another project**

AutoCAD Electrical quickly scans a previous project, finds the instance of that component, and returns the catalog information to you. It is accomplished without leaving your active drawing. In the Insert/Edit dialog box, click Project. In the Find: Catalog Assignments dialog box, select Other project and click OK. AutoCAD Electrical processes the project you select. It quickly scans each listed drawing for the target component type and returns a list of what it found. You can then make your catalog assignment by picking from this list.

### **Pull from an external file**

You can pull catalog assignments from a generic ASCII file created by a word processor or output from a spreadsheet or database program. In the Insert/Edit

dialog box, Catalog Data section, click Project. In the Find: Catalog Assignments dialog box, select External file, and click OK.

### **Pull from your own external database application**

AutoCAD Electrical provides a means to bypass its internal catalog part number look-up and temporarily pass control to your custom catalog part number selection application. In the Insert/Edit dialog box, Catalog Data section, click Lookup. But instead of immediately accessing the appropriate catalog look-up table, AutoCAD Electrical passes control to your application. You make the MFG/CAT/ASSYCODE selection in your own database program. Your application formats your selection and passes it back to AutoCAD Electrical.

### **Add multiple BOM catalog numbers to a component**

You can add additional part numbers to any schematic or panel component on the fly. These multiple BOM part numbers appear as subassembly part numbers to the main catalog part number in the various BOM and component reports. In the Insert/Edit dialog box, click Multiple Catalog to show a dialog box for adding the extra catalog part numbers.

### **Assign catalog information**

- 1 Insert or edit a schematic component symbol on your drawing.  
The Insert/Edit Component dialog box displays so you can assign component-specific information to the new component.
- 2 In the Insert/Edit Component dialog box, Catalog Data section, click Lookup to choose a vendor part number to assign to this instance of the component.  
AutoCAD Electrical reads the AutoCAD block name of the inserted component and determines the correct table to access in the catalog lookup database file (default\_cat.mdb).  
The WDBLKNAM field in the family table is used as the first filter when opening the catalog lookup window for the selection of catalog numbers. This filter is on by default and removes invalid selections from the catalog lookup window.
- 3 Sort the catalog records.
  - Click the column heading to sort the catalog records based on the values in the selected field. The first click sorts from A to Z so the lowest values are at the top of the column. The second click sorts from Z to A.

- Click the drop-down arrow on the column heading and select a sort option from the menu.
- 4 To filter the catalog records, click the drop-down arrow on the column heading. A list of unique values for the selected field displays. Select the fields to show or hide from the list.

---

**NOTE** If there are over 450 unique values to display, the list is not available.

---

- 5 Search the entire catalog database for a catalog value.
- Enter a catalog value in the search box. [Catalog Database Search - Wildcards](#) on page 1291 are allowed.
  - Click the search icon. If the catalog is found, the [Catalog Search Results](#) on page 1291 dialog box displays.
  - Select a catalog table from the list of tables. The list of matching catalog values displays.
  - Select a catalog value from the list.
  - Click OK. The catalog value is assigned to the component. The Parts Catalog dialog box displays.
- 6 To search within a field, enter a value in the search box at the top of the field. The matching catalog records display as you enter the search value.

---

**NOTE** Delete the text in the search field to clear the search for the field. Select the Clear All button to clear all field search values.

---

- 7 To reorder the columns, click a column heading and drag it to the desired position in the grid display.

---

**NOTE** To reset the column order to the original catalog order, right-click on a column header and click Reset Column sequence.

---

- 8 Change the columns displayed or column sizing.
- Right-click on a column header.
  - Check the columns to display.
  - Uncheck the columns to hide.
  - Select from the column sizing options.



---

**NOTE** Changing the display does not affect the catalog database, only the way the catalog records are viewed.

---

- 9 In the Parts catalog dialog box, select the vendor and catalog part number to use.

The invisible MANUFACTURER, CATALOG, and ASSEMBLYCODE attributes of the block are populated with the key values pulled from the selected record in the target table. Various description and miscellaneous field values from the picked record are not saved on the attributes of the block. Only the MANUFACTURER, CATALOG, and ASSEMBLYCODE values are saved.

When you finish modifying component information, you can run the Schematic Bill of Material report. The report queries the MANUFACTURER, CATALOG, and ASSEMBLYCODE attribute values of the inserted component. AutoCAD Electrical then formats and outputs a detailed BOM report.

## Parts catalog

Select a catalog value from the catalog database to assign to the selected component. Search the database for a specific catalog item. Filter the database list based on selected or entered values. Add or modify catalog database values.

### Insert Component

 **Ribbon:** Schematic tab > Insert Components panel > Insert

Components drop-down > Icon Menu.



 **Toolbar:** Main Electrical

 **Menu:** Components > Insert Component

 **Command entry:** AECOMPONENT

Select the component type to insert and specify the insertion point on the drawing. Click Catalog Data: Lookup.

## Edit Component

 **Ribbon:** Schematic tab ► Edit Components panel ► Edit Components

drop-down ► Edit.

 **Toolbar:** Main Electrical

 **Menu:** Components ► Edit Component

 **Command entry:** AEEDITCOMPONENT

Select the component to edit. Click Catalog Data: Lookup.

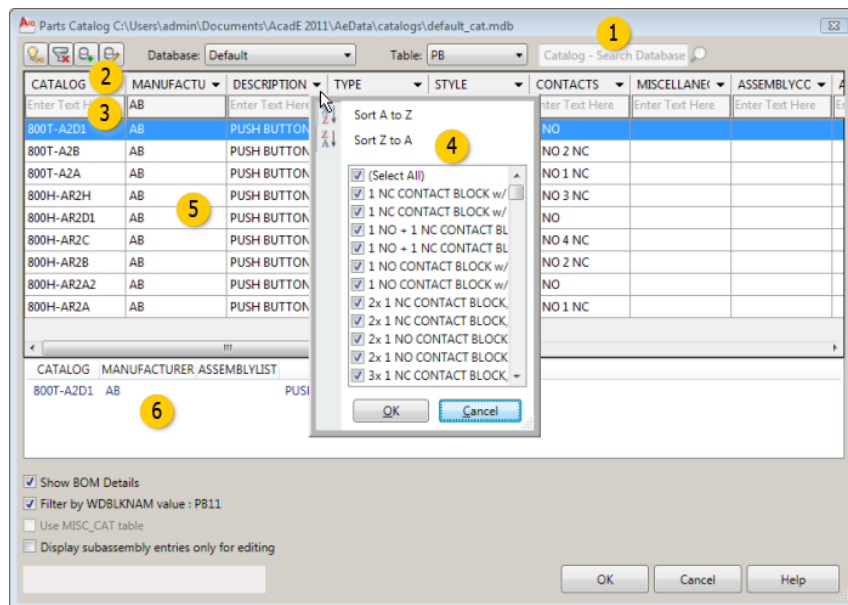

## View Web Link



Displays more information about the component, such as pictures, specifications, or a Web URL. Use the 15th field in the catalog database to set up the link.

If the WEBLINK field for the selected part is a Web URL, your Internet browser launches and displays it. If it is an image file, PDF, spreadsheet, or some other document type, the application associated with the file extension (for example, "Open With...") launches and displays the contents of the file.

#### Clear All Filters



---

**NOTE** Also available on the right-click context menu.

---

Clears all selected filters or entered search values. This option does not clear the Filter by WDBLKNAM value option.

---

**NOTE** Also available on the right-click context menu.

---

#### Add Catalog Entry



Adds a catalog item to the catalog database file with values you enter on the [Add Catalog Record](#) on page 1295 dialog box. If you select an existing catalog entry, the fields populate with values from that entry.

---

**NOTE** Also available on the right-click context menu when clicking an entry in the grid or the BOM Details area.

---

#### Edit Catalog Entry



Edits a catalog record. In the Parts Catalog dialog box, select the catalog record to edit. In the Edit Catalog Record dialog box, change any values.

---

**NOTE** Also available on the right-click context menu when clicking an entry in the grid or the BOM Details area.

---

#### Database

Selects a catalog database between the defined alternate database and the default catalog database.

#### Table

Displays a list of the component tables in the active catalog database. Select a table, or create a table.

Select New Table to create a table. To create a component-specific table, select the Component button from the [Add new table to MDB](#) on page 1298 dialog box.

---

**NOTE** If you select to create a table, and then cancel the dialog box before adding any data to the table, the blank table is deleted.

---



Searches the catalog field across the entire catalog database. The [Catalog Search Results](#) on page 1291 dialog box displays the search results. [Catalog Database Search - Wildcards](#) on page 1291 are allowed.



Sorts the catalog database information when you click the column headings. Filters the catalog database by values you select in the drop-down list.



Searches the catalog database for data with fields that match the entered text.

---

**NOTE** The field search assumes an ending “\*” wildcard allowing it to display matching values as you enter the search value.

---



- Sorts the catalog database information.
- Filters the catalog database by values you select in the drop-down list.

---

**NOTE** If there are over 450 unique values to display, the drop-down list is not available.

---



Displays the catalog entries that match the current settings.



Displays the results when Show BOM Details is checked. The main catalog and any related subassembly items are shown. Right-click on a catalog entry in the BOM details area to edit the entry or add a copy of the entry to the catalog database.

**Show BOM Details**

Performs a check of the Bill of Material, and displays the result for the selected catalog value.

**Filter by WDBLKNAM name**

Filters the symbol names using the [WDBLKNAM](#) on page 1276 value. If you select this option, records that contain a WDBLKNAM value that does not match the symbol block name do not display in the catalog list. If this option is not selected, the query ignores the check on the WDBLKNAM field and returns all catalog information.

**Display subassembly entries only for editing**

Displays records defined as subassemblies in the catalog display. You can edit the subassembly items you display. You cannot assign a subassembly directly to a component. A value in the ASSEMBLYLIST field defines a record as a subassembly item. The data for the subassembly items are used in reports.

**Use MISC\_CAT table**

References a table called MISC\_CAT. This general catalog table in the database file is set up with all component types.

If found, this catalog information displays in the dialog box for component catalog number selection.  
If the table does not exist, it is created automatically. Use the Add Catalog Entry button to add records.

### Conductor List

Opens the Edit Catalog Conductor List dialog box. Edit the cable conductor database table (\_WO\_CBLWIRES) for the selected Manufacturer and Catalog combination.  
You can delete or change existing cables or add new ones to the list.  
Available for cable markers only.

### Default filters

A catalog table can contain thousands of records. The program uses this default filtering when the Parts Catalog dialog box displays:

- If the component has a catalog assignment, filters based on the manufacturer, type, and style for that catalog.
- If the component does not have a catalog assignment, filters based on the [\\_LISTBOX\\_DEF](#) on page 1277 entry for the catalog table.
- If the component does not have a catalog assignment, and no [\\_LISTBOX\\_DEF](#) entry exists for the table, the program filters on the manufacturer, type, and style of the first record in the catalog table.

---

**NOTE** Manufacturer is the second field, type is the fourth field, and style is the fifth field in a catalog table regardless of the actual column labels.

---

### Column display

Click a column header and drag the column to the desired position in the display to change the column display order.



Right-click over a column heading to display the context menu.

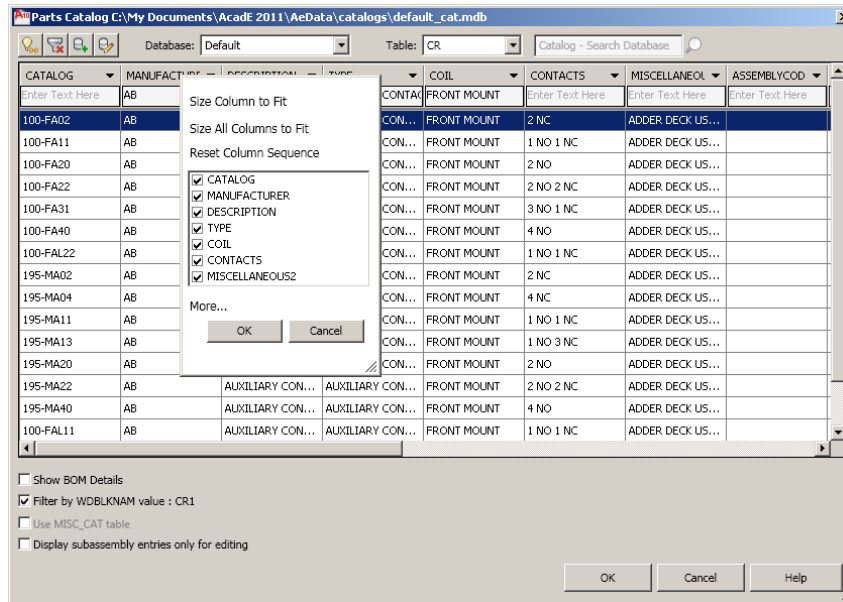

**Size Column to Fit**

Adjusts the size of the column under the cursor to fit the text values within that column.

**Size All Columns to Fit**

Adjusts the size of all columns to fit the text values within each column.

**Reset Column sequence**

Resets the column sequence to match the column order in the catalog database.

**Column name listing**

Shows a listing of column names and current visibility. A check mark indicates the column is included in the display. Select which columns to display and which to hide.

**More**

Displays Columns dialog box listing all available columns. Use this listing if not all columns display in the menu.

The column display settings are remembered across AutoCAD Electrical sessions. The catalog database column order remains unchanged. Only the display changes.

## Catalog Database Search - Wildcards

Character	Definition
# (pound)	Matches any numeric digit
@ (at)	Matches any alphabetic character.
* (asterisk)	Matches any string and can be used anywhere in the search string
? (question mark)	Matches any single character; for example, ?BC matches ABC, 3BC, and so on
~ (tilde)	Matches anything but the pattern; for example; ~*AB* matches all strings that do not contain AB
' (reverse quote)	Reads the next character literally; for example, '~AB matches ~AB

## Catalog Search Results

Displays the catalog values search results based on a catalog search from the Parts Catalog dialog box.

### Insert Component

 **Ribbon:** Schematic tab ► Insert Components panel ► Insert

Components drop-down ► Icon Menu.

 **Toolbar:** Main Electrical

 **Menu:** Components ► Insert Component

 **Command entry:** AECOMPONENT

Select the component type to insert and specify the insertion point on the drawing. Click Catalog Data: Lookup. Enter a search value and select the search

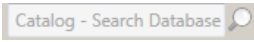
icon. 

## Edit Component

 **Ribbon:** Schematic tab ► Edit Components panel ► Edit Components

drop-down ► Edit.

 **Toolbar:** Main Electrical

 **Menu:** Components ► Edit Component

 **Command entry:** AEEDITCOMPONENT

Select the component to edit. Click Catalog Data: Lookup. Enter a search value and select the search icon. 

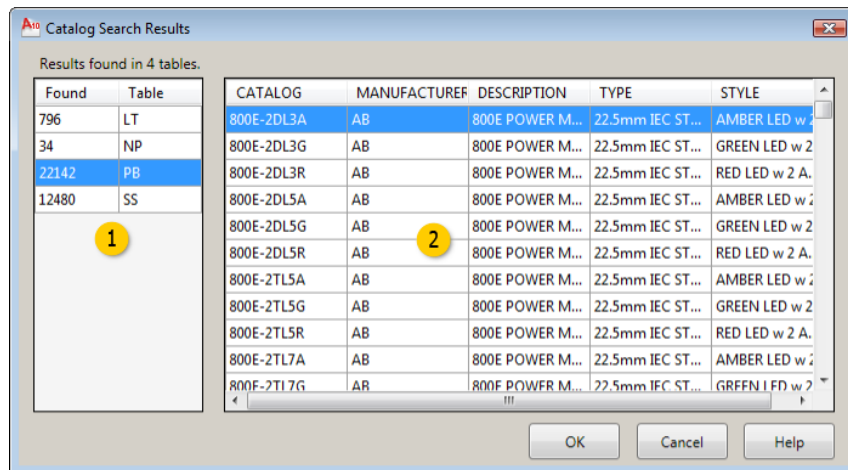

Displays a list of the tables, and the number of records in the table, containing the catalog value. Select a table to display the records within that table that match the search value.



Displays the catalog records in the selected table that match the search value. Click a column heading to sort the records based on the values in that column.



**OK** Assigns the selected catalog value to the component on the Parts Catalog dialog box.

## Catalog values

Lists the catalog part number information for any or all components (or footprints) that have the same family block name (WDBLKNAM value) as the component being edited.

**Catalog Check** Displays its bill of materials description.

**OK** Copies the highlighted catalog information to the component being edited.

## Component catalog lookup

This tool creates a component-specific or general family catalog table.

### Insert Component

**Ribbon:** Schematic tab ► Insert Components panel ► Insert Components

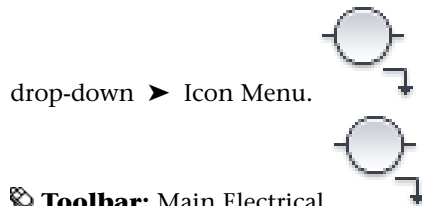

**Toolbar:** Main Electrical

**Menu:** Components ► Insert Component

**Command entry:** AECOMPONENT

On the Insert/Edit dialog box, click Catalog Lookup. If there is no catalog table for the component, an alert displays. Click OK.

### Insert Footprint (Icon Menu)

**Ribbon:** Panel tab ► Insert Component Footprints panel ► Insert

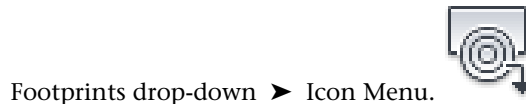

**Toolbar:** Panel Layout



 **Menu:** Panel Layout ► Insert Footprint (Icon Menu)

 **Command entry:** AEFOOTPRINT

On the Insert/Edit dialog box, click Catalog Lookup. If there is no catalog table for the footprint, an alert displays. Click OK.

### Option A

Creates a catalog table now.

#### Component

Creates a component-specific catalog table. The name of this catalog table matches the block name for the component (minus the "H" or "V" first letter). For example, both horizontal and vertical versions of a standard, N.O. push button ("HPB11" and "VPB11") reference the same component-specific catalog look up table "PB11".

#### Family

Creates a family catalog table. The name of this catalog table consists of the 2nd and 3rd characters of the block name for the component. For panel footprints, the name consists of the first two characters of the WDBLKNAM value. For example, all the limit switch blocks used on your schematics have "LS" embedded in their block names: "HLS11", "HLS12", "VLS11", and so on. Instead of a component-specific catalog file, you can create a general limit switch catalog look up table, "LS." This table is referenced if a component-specific version is not found.

### Option B

References a miscellaneous table.

#### Miscellaneous

References a table called "MISC\_CAT." This general catalog table is set up in the .mdb file with all component types in it. If found, this catalog information displays in the dialog box for component catalog number selection.

## Modify or expand catalog tables

You can edit entries in a catalog table or even add new catalog items on-the-fly using AutoCAD Electrical.

- 1 Force AutoCAD Electrical to reference the appropriate catalog table. Insert a new component related to the catalog table you want to edit, or pick an existing component of that type to edit with the Edit Component tool.

For example, suppose you want to add some new components to the catalog table for standard red pilot lights (LT1R). Use AutoCAD Electrical to insert a new red pilot light symbol, or edit a red pilot light symbol.

- 2 From the Insert/Edit dialog box, select Catalog lookup. Now you have triggered AutoCAD Electrical to open the desired catalog table.

- 3 Select Add Catalog Entry  to add a new item or select Edit Catalog

Entry  to edit the selected database record. AutoCAD Electrical displays the new or existing catalog record in a dialog box.

- 4 Make the necessary changes and click OK to exit the Add/Edit Catalog Entry dialog box.

To add a new table to the catalog file:

- Insert a new component that triggers AutoCAD Electrical to ask permission to create the table.
- On the [Parts catalog](#) on page 1285 dialog box, select Table: New Table.
- Run [Add new table to catalog database](#) on page 1298.

### **Add or edit catalog record**

- Add Catalog Entry - adds a catalog item to the catalog database file with values you enter on the Add Catalog Record dialog box. If you select an existing catalog entry, the fields populate with values from that entry.
- Edit Catalog Entry - edits a catalog record. In the Parts Catalog dialog box, select the catalog record to edit. In the Edit Catalog Record dialog box, change any values.

## Insert Component

 **Ribbon:** Schematic tab ► Insert Components panel ► Insert

Components drop-down ► Icon Menu.



 **Toolbar:** Main Electrical

 **Menu:** Components ► Insert Component

 **Command entry:** AECOMPONENT

Select the component type to insert and specify the insertion point on the drawing. Click Catalog Data: Lookup. In the Parts Catalog dialog box, click Add Catalog Entry or Edit Catalog Entry.

## Edit Component

 **Ribbon:** Schematic tab ► Edit Components panel ► Edit Components

drop-down ► Edit.



 **Toolbar:** Main Electrical

 **Menu:** Components ► Edit Component

 **Command entry:** AEEDITCOMPONENT

Select the component to edit. Click Catalog Data: Lookup. In the Parts Catalog dialog box, click Add Catalog Entry or Edit Catalog Entry.

AutoCAD Electrical uses the first ten fields for its own use plus reserves an additional three user fields for your use. You can insert additional fields, but AutoCAD Electrical ignores them when it constructs various reports.

<b>Catalog</b>	Specifies the catalog number.
<b>Count</b>	Specifies the number of parts to add to the BOM. A blank Count indicates a quantity of 1. A valid non-blank Count is 1 through 100.
<b>Manufacturer</b>	Specifies the manufacturer for the catalog part.

<b>Description</b>	Specifies the optional description text for the catalog part.
<b>Type</b>	Specifies the type for the catalog part.
<b>Coil/Voltage/Color</b>	The type of value can vary based on the type of component. This value populates the fifth field in the catalog record.
<b>Miscellaneous/Contacts</b>	Specifies the contacts or the first miscellaneous field assigned to the part. The type of value can vary based on the type of component. This value populates the sixth field in the catalog record.
<b>Miscellaneous</b>	Specifies miscellaneous text to assign to the part.
<b>Assemblycode</b>	Specifies the code to flag that this item has subassembly items. "As main- ► subassembly" activates the Assembly Code edit box. Use a unique name code to link this main catalog item with other subassembly items. This code can be up to 60 characters. Spaces are allowed.
<b>Assemblylist</b>	Specifies the code to flag as a subassembly item of a main item. To enter the ASSEMBLYLIST value, select "As sub-assembly" and enter the exact name of the ASSEMBLYCODE value carried by its main component. You can select the ASSEMBLYCODE list switch to speed up the process.
<b>User 1,2,3</b>	Specifies user information. AutoCAD Electrical provides three blank user fields for your use. Each can be a maximum of 24 characters wide and are extracted into BOM reports along with all the other fields.
<b>Textvalue</b>	Specifies optional user-defined RATING/misc attribute values. This field is used to assign text values to specific attributes on the edited component. The format for the text data encoded into this field is: <attribute tag name1>=<text value>;<attribute tag name2>=<text value>
<b>Weblink</b>	Specifies the .pdf file or Web URL to associate to the component. If the Weblink entry is a Web URL, your Internet browser displays it. If it is an image file, .pdf, spreadsheet, or some other document type, then the application associ-

ated with that file extension (for example, "Open With...") displays the file.

---

**NOTE** For ".pdf" display, you can include the page number to display upon document open. Add a space and the page number after the .pdf file name in the WEBLINK field value (for example, c:\rockwell\700series.pdf 13).

---

#### WDBLKNAM

Specifies the schematic block name (used for catalog lookup - that is, PB11, CR) of the catalog record. It serves as a filtration of the catalog records based on the schematic block name. This field is used in the Filter by WDBLKNAM value when opening up the catalog lookup dialog box. This filter provides the mechanism to remove invalid selections from the catalog lookup window, much like the component-specific tables.

---

**NOTE** Use a comma to separate multiple symbol block names.

---

#### Force text to uppercase

Displays all the specified values in all upper case.

#### Delete

Deletes the catalog record.

---

**NOTE** Only available on the Edit Catalog Record dialog box.

---

## Add new table to MDB

Adds a new, blank table to the selected database file.

 **Ribbon:** Project tab > Other Tools panel >  > Add Table to

 Catalog Database.

 **Menu:** Projects > Extras > Add Table To Catalog Database

 **Command entry:** AEADDCATALOGTABLE

---

**NOTE** This dialog is also accessed when a [new table](#) on page 1294 is added to the catalog database from the Parts Catalog dialog box.

---

<b>MDB file to modify</b>	Specifies the file name of the Catalog Database file to modify.
<b>Existing tables</b>	Lists the existing tables found in the file.
<b>Table Name</b>	Specifies the name of new table to add to the selected catalog database. The new, blank table inserts with the default fields defined (for example, the fields needed for the catalog lookup function).
<b>Component</b>	Creates a component-specific table for the catalog database. <hr/> <b>NOTE</b> Only available when accessed from the Parts Catalog dialog box. <hr/>
<b>Table Description</b>	Specifies the description for the table. If the selected database file is a catalog file, an entry is also added to the <a href="#">_FAMILY_DESCRIPTION</a> on page 1267 table. The entry contains the table name and description.

## Copy catalog assignments from component to component

### Copy catalog assignments from component to component

Copies a component catalog number assignment to other selected components.

Select the master component from which to copy the catalog data. Select the components to which you copy the catalog data.

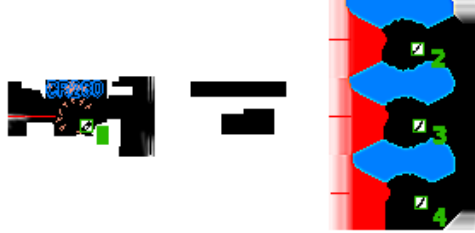

- 1 Click Schematic tab ► Edit Components panel ► Edit Components



drop-down ► Copy Catalog assignment.

- 2 Select the master component from which to copy the catalog data.
- 3 Select the part number information by clicking Catalog Lookup, Find: Drawing Only, Multiple Catalog, or Catalog Check.
  - **Catalog Lookup:** Select the catalog table information in the Parts Catalog dialog box for the selected component type and click OK.
  - **Find: Drawing Only:** Select from the catalog part number information for any/all component footprints that have the same family block name as the component being edited. Click OK.
  - **Multiple Catalog:** Insert extra catalog part numbers onto the currently selected component or footprint. You can add up to 99 additional part numbers to any schematic or panel component on-the-fly. Click OK.
  - **Catalog Check:** Quickly performs a bill of material check and displays the result.
- 4 Click OK.
- 5 Select the devices to copy the catalog data to.

---

**NOTE** Child or related devices are not automatically updated. They must be included in the selection.

---

## Multiple bill of material information



This tool allows you to insert or edit extra catalog part numbers on to the currently selected component or footprint. You can add up to 99 additional part numbers to any schematic or panel component on-the-fly. These multiple BOM part numbers appear as subassembly part numbers to the main catalog part number in the various BOM and component reports.

On the Insert/Edit Component or Panel Layout - Component Insert/Edit dialog box, Catalog Data section, click Multiple Catalog.

---

**NOTE** You can also access this dialog box by clicking Multiple Catalog on the [Copy Catalog Assignment](#) on page 1299 dialog box.

---

The additional catalog part numbers are saved on the symbol as MFGn/CATn/ASSYCODEn attribute values. The "n" is the sequential code value "01" through "99" selected in the top list box. If these attributes are not present on the symbols, AutoCAD Electrical saves the information as Extended Entity Data (Xdata) on the block insert.

#### **Sequential code**

Adds up to 99 extra part numbers (in addition to the main catalog part number). Pick which one you want to add or inspect/edit. Click the list button to show all extra part numbers carried on the component.

#### **Catalog Data**

Specifies the catalog part number information such as the manufacturer and catalog number.

#### **Count**

Specifies the quantity number for the extra part number (blank=1). This value gets inserted into the "SUBQTY" column of a BOM report.

#### **Unit**

Specifies the unit of measure, which can be displayed in the component list report.

#### **Parts Catalog Lookup**

Lists the catalog database table that is to be referenced for the description information for the given Manufacturer/Catalog/Assembly combination. For each catalog entry, provide a name for the catalog look-up table. For the main catalog entry, this information is provided on the symbol itself but may not

be there for these catalog entries. Select List to pick from a list of tables that are contained in your catalog database file or Misc to use the MISC\_CAT table.

### Catalog Lookup

Checks for and displays catalog table information in the Parts Catalog dialog box for the selected component type.

### Catalog Check

Quickly performs a Bill of Material check and displays the result.

### Item Number

Assign an item number to the catalog number.

**fixed** If checked, marks an item number as fixed. If you run [Resequence Item Numbers](#) on page 1602 later on, fixed item numbers do not change.

---

**NOTE** The fixed check box is available only when assigning the catalog to panel components.

---

**Drawing: Find** Finds the assigned manufacturer, catalog, assembly code combination on components on the active drawing. If a match is found, the item number is assigned to this catalog. If a match is not found, a dialog box displays where you enter an item number or use the next available.

---

**NOTE** If the [Item Numbering Mode](#) on page 211 is Accumulate Project Wide, this button is disabled.

---

**Drawing: List** Lists the item numbers along with each manufacturer, catalog, assembly code combinations in use on the active drawing.

---

**NOTE** If the [Item Numbering Mode](#) on page 211 is Accumulate Project Wide, this button is disabled.

---

**Project: Find** Finds the assigned manufacturer, catalog, assembly code combination on components on the drawings in the active project. If a match is found, the item number is assigned to this catalog. If a match is not found, a dialog box displays where you enter an item number or use the next available.

---

**NOTE** If the [Item Numbering Mode](#) on page 211 is Reset with Each Drawing, this button is disabled.

---

**Project: List**

Lists the item numbers along with each manufacturer, catalog, assembly code combinations in use on the drawings in the active project.

---

**NOTE** If the [Item Numbering Mode](#) on page 211 is Reset with Each Drawing, this button is disabled.

---

If the [Item Assignments](#) on page 211 project setting is set Per-Component Basis, this section is disabled.

## Multiple catalog part number assignments

This dialog box displays the order in which the extra part numbers appear in the various AutoCAD Electrical reports. You can add up to 99 additional part number assignments to a component.

On the Insert/Edit Component or Panel Layout - Component Insert/Edit dialog box, Catalog Data section, click Multiple Catalog. Click Sequential Code: List on the Multiple Bill of Material Information dialog box.

---

**NOTE** You can also access this dialog box by clicking Multiple Catalog on the [Copy Catalog Assignment](#) on page 1299 dialog box and clicking Sequential Code: List.

---

To change the order, highlight the part number and click Move Up or Move Down to move it in the list.

## Show missing catalog assignments

Use the Show Missing Catalog Assignments tool to indicate graphically or list the parent or stand-alone components that do not carry catalog information on the active drawing.



Click Reports tab ► Schematic panel ► Missing Catalog Data.

**Show**

Displays the components that do not carry catalog information. They are marked on the screen with a red diamond shape drawn

around the insertion point of the symbol in temporary graphics. A REDRAW restores the screen to its original state.

#### Report

Extracts the information from the active drawing or project and displays a list of parent or stand-alone components without catalog information.

---

**TIP** Extracted BOM data can be output to a spreadsheet file, mdb database file, text report file, or comma-delimited for export to a spreadsheet or database program. It can also be inserted, in tabular form, on the current AutoCAD drawing.

---

## Contact Quantity/Pin List Lookup

### Use pin lists

AutoCAD Electrical can automatically track how many contacts were assigned to a device like a relay or timer coil. When a newly inserted contact exceeds a predefined limit, AutoCAD Electrical can alert you. AutoCAD Electrical can also track available terminal pin number pairs as you insert each new contact. It can also automatically give you the next available pair as a default.

To enable this feature, maximum contact count and pin number pair information is assigned to the parent symbol (ex: relay or timer coil symbol). It is carried as Xdata under the name VIA\_WD\_PINLIST. If a PINLIST attribute is present on the parent device, the pin list is carried on this invisible attribute. A copy of this pin list data is carried in the Access catalog database file of the project (<project>\_cat.mdb or default\_cat.mdb) in a table called \_PINLIST or \_PINLIST\_{manufacturer}. This information can be assigned manually. It can also be automatically retrieved from a pin list database table when a catalog part number is assigned to the parent device. As each contact is inserted and referenced back to the parent, AutoCAD Electrical checks the pin information carried on the parent and verifies that a contact of the proper type is available. If so, it retrieves the next pair of contact pin numbers from the parent and displays as defaults for the new contact.

The AutoCAD Electrical automatic pin list lookup and assignment at component insertion time is not limited to devices that have contacts. You can encode two wire devices like pilot lights or proximity switch into the database file. Insert the MFG and CAT numbers and fill in the COILPINS field with the terminal pin numbers. Leave the PINLIST field blank. When you

insert one of these devices and perform a Catalog lookup and part number selection, AutoCAD Electrical quickly looks for a MFG/CAT match in the pin list database. On a match AutoCAD Electrical pulls out the coil pin numbers of the device and automatically inserts them on to the newly inserted device.

### Pin list data carried on the parent

When AutoCAD Electrical annotates a parent coil or other device with the pin list information, AutoCAD Electrical inserts it on the following attributes (if present):

<b>PINLIST</b>	The pin list format string of 3-element groups, one for each available contact
<b>MAXNO</b>	Maximum N.O. contact count, blank means undefined, 0 means none allowed
<b>MAXNC</b>	Maximum N.C. contact count
<b>MAXNONC</b>	Maximum convertible contact count

If these attributes are not present, AutoCAD Electrical encodes the data on to the symbol as extended entity data. If AutoCAD Electrical finds a MFG/CAT match in the pin list database and retrieves the encoded pin list information, it pre-fills the MAXNO, MAXNC, and MAXNONC values with the quantities derived from the decoded pin list data.

To view or manually edit these values, select Edit Component and click the NO/NC Setup button on the Insert/Edit dialog box. AutoCAD Electrical maintains a copy of the PINLIST information of the parent in the scratch database file of the project (in Microsoft Access format). You can view it by opening the PINLIST table of the user\

### Modify the pin list database

The pin list database file can be viewed, edited, and expanded using the Pin List Database Editor tool.

---

**NOTE** This tool is not limited to relays and timers, but can be extended to other switch types that can have extra contacts, plug/jacks, and stand-alone PLC I/O points.

---

- 1 Click Schematic tab ➤ Other Tools panel ➤  ➤ Database Editors drop-down ➤ Pin List Database Editor. 

- 2 In the Select Pin List Table dialog box, select the table to edit and click Edit.

---



**NOTE** You can also create a table by entering the manufacturer name in the edit box and clicking Create.

---

- 3 In the Edit dialog box:
  - To edit a record, click Sort, Filter, or Find to search for the record to edit. Select the record from the list and click Edit.
  - To create a record, click Add New, or select an existing record and click Add Copy to create a record based on an existing one.
  - To delete an existing record, select the record in the list and click Delete.
- 4 To edit or create a record, in the Edit Record dialog box, specify the values to assign to the record and click OK.
- 5 In the Edit dialog box, click Save/Exit.

## Select pin list table

This tool allows you to select the relevant PINLIST table to edit or create a new one.

-  **Ribbon:** Schematic tab ➤ Other Tools panel ➤  ➤ Database Editors drop-down ➤ Pin List Database Editor. 

 **Menu:** Components ➤ Cross-Reference ➤ Pin List Database Editor

 **Command entry:** (AEPINLISTTABLE)



**Select or Type Manufacturer**

Lists the PINLIST tables found in the catalog database. The “(Default)” manufacturer is used to edit the generic \_PINLIST table.

	Select the table to edit or enter a name for a new one.
<b>Table</b>	Displays the proper table name in the catalog database. This text changes depending on which manufacturer is selected. For example, if you select SQD, then <code>_PINLIST_SQD</code> appears.
<b>Create</b>	Creates a table in the catalog database with the specified name and adds the table to the list of manufacturers. Once a table is created, the Edit (Table: <code>_PINLIST_manufacturer</code> ) dialog box appears so you can edit the new table. This choice is available only when you enter the name of a manufacturer.
	<b>NOTE</b> The following characters are not allowed in the table name: <code>~ @ # \$ % ^ &amp; * - + = \ { } " ' ; : ? / &lt; &gt; , ! [ ]  </code> . If entered in the edit box, these characters are replaced with an underscore ( <code>_</code> ).
<b>Edit</b>	(available only after a manufacturer is selected from the list) Opens the Edit (Table: <code>_PINLIST_manufacturer</code> ) dialog box so you can edit the selected PINLIST table.

## Edit

AutoCAD Electrical consults a pin list database table when a part number is added or an existing part number is changed on a parent schematic symbol. If AutoCAD Electrical finds a match on the MFG, CAT, and optional ASSYCODE values for the part number in this database table, then the associated contact count and pin number information is retrieved and placed on the parent schematic component.

 **Ribbon:** Schematic tab ► Other Tools panel ►  ► Database

 Editors drop-down ► Pin List Database Editor.

 **Menu:** Components ► Cross-Reference ► Pin List Database Editor

 **Command entry:** (AEPINLISTTABLE)

Specify the table to create and click Create or select the table to edit and click Edit.

This lookup database table is a table within the catalog lookup Access .mdb file. The default file name is default\_cat.mdb, table \_PINLIST, and comes populated with a sample of vendor data. You can expand this table as needed. Use your own copy of Microsoft Access or this dialog box to add new entries, add entries based on existing entries, edit, and delete entries from the table.

<b>Sort</b>	Sorts the list of database records using either an alphanumeric sort or number values. You can specify four sorts to perform on the list.
<b>Find</b>	Sorts the list of database records using either an alphanumeric sort or number values. You can specify four sorts to perform on the list.
<b>Replace</b>	Indicates to replace the find value with the new text string that you specify.
<b>Filter</b>	Filters the listing based on certain values in the table. Picking the blank entry in the list removes the filter for that field. After you define the values to filter, apply the filter in the database editing window.
<b>Edit</b>	Displays the Edit Record dialog box for modifying the existing record in the database.
<b>Add New</b>	Displays the Edit New Record dialog box for entering a new record into the database.
<b>Add Copy</b>	Displays the Edit Copied Record dialog box for modifying and copying the record to make a new record. You cannot have two duplicate copies in the database.
<b>Delete</b>	Removes the selected record from the database.



### Structure of the pin list database table

RECNUM	(Microsoft Access internal use)
MANUFACTURER	Manufacturer code (value must be consistent with the catalog lookup files)
CATALOG	Catalog number (use wildcards as much as possible)



ASSEMBLYCODE	AutoCAD Electrical internal assembly code (must be consistent with the catalog lookup files)
COILPINS	Terminal pin numbers for coils (separate multiple pins with commas)
PINLIST	Contact type and pin numbers
PEER_COILPINS	Terminal pin numbers for peer coil
PEER_PINLIST	Contact type and pin numbers

## Edit record

 **Ribbon:** Schematic tab > Other Tools panel >  > Database

Editors drop-down > Pin List Database Editor.

 **Menu:** Components > Cross-Reference > Pin List Database Editor

 **Command entry:** (AEPINLISTTABLE)

Specify the table to create and click Create or select the table to edit and click Edit. In the Edit dialog box, click Add New, Add Copy, or Edit.

### MANUFACTURER

Specifies the Manufacturer code (value must be consistent with the catalog lookup files).

### CATALOG

Specifies the Catalog number (use wildcards as much as possible).

### ASSEMBLYCODE

Specifies the AutoCAD Electrical internal assembly code (must be consistent with the catalog lookup files).

### COILPINS

Specifies the terminal pin numbers for a coil. This value is generally two pin numbers separated by a comma (for example, K1,K2), but is not limited to just two pin numbers. At insertion/annotation time, AutoCAD Electrical applies

this list to the TERMxx attributes it finds on the parent symbol. If the parent itself can be either a N.O. or N.C. contact, encode the COILPINS field like the PINLIST field. For example, a value of "1,A1,A2;2,B1,B2" for a target mfg/cat record in the \_PINLIST table applies pins "A1/A2" to the parent device pins if the device is a generic N.O., and "B1/B2" if it is a generic N.C. device. Repeat these values in the PINLIST field so that AutoCAD Electrical can correctly track all contacts.

### **PINLIST**

Specifies the Contact type and pin numbers. This value is a sequence of two or more element groups with each group defining one available child contact element for the device. For a two terminal contact, there are three elements in the group. It follows this format:

Contact type, terminal pin, terminal pin

In this format, Contact type = 1 for N.O., 2 for N.C., 0 for convertible contact, 3 for Form-C (NO/NC pair), 4 for multi-pole terminal strips or undefined type, and 5 for multiple-pin or stacked terminals. AutoCAD Electrical also allows a description label associated with a pin pair. To add description labels, encode the \_PINLIST database table entry using a format like:

```
1,A1X,A1Y;1,A2X,A2Y,*aux contact=";2,B1X,B2Y,*NC=;
```

In this format, the optional comment is always the last element of the sublist and follows an asterisk character. If no asterisk is present, then the comment is interpreted as another pin number). The previous example would display in the pin list pick list dialog box as:

```
A1X,A1Y
```

```
aux contact=A2X,A2Y
```

```
NC=B1X,B2Y
```

Convertible contacts encoded as type 0, followed by two pin numbers, assume that the pin numbers do not change when a contact is flipped between N.O. and N.C. If the pin number of the contact changes based on the difference between the N.O. and N.C. configurations, encode each type 0 entry as "0,pinNO,pinNO,pinNC,pinNC;". The first two entries after the "0" flag give the pin number for the N.O. configuration and the second two for the N.C. configuration. AutoCAD Electrical picks the correct pair based upon the contact type being inserted or edited.

For contact type 3 (Form-C), the pins must be entered in this order: common pin, NO pin, NC pin. A Form-C contact set with NO on pin 5, NC on pin 6, and pin 8 common to both contacts would be encoded as 3,8,5,6 where "3"

flags "Form-C", "8" is the common pin, "5" is the NO pin, and "6" is the NC pin.

#### **PEER\_COILPINS, PEER\_PINLIST**

There can be two additional "PEER\_" fields in the \_PINLIST table for defining special cases where a single part number calls out two parent devices. For example, a reversing motor starter part number can include two parent contactor coils, one for forward and one for reverse. Each parent coil symbol must have its own pin list assignment. You set up the coil pins and pin list data of the second coil in the PEER\_COILPINS and PEER\_PINLIST fields for the common part number.

- **PEER\_COILPINS:** Terminal pin numbers for peer coils.
- **PEER\_PINLIST:** Contact type and pin numbers.

## **Set pin list assignments for special uses**

You can set up subcategories of type 4 pin combinations so that some apply to specific contact types and other pin combinations to other contact types. You can also use a type 4 PINLIST assignment to track and control how many schematic terminal symbols can be tied to a given terminal tag-ID.

#### **For filtering of special contact use**

You can set up subcategories of type 4 pin combinations so that some apply to specific contact types and other pin combinations to other contact types. Encode the Pin List entries with a "4" plus a character to provide further filtering of what contacts are available for a given child contact. At the contact end, an attribute PINLIST\_TYPE (or Xdata of the same name) must carry a value of "4" plus a character to match up with the coding in the pin list string.

For example, a given device has 5 N.O. contacts but they are not all the same. Three of them are motor contacts and 2 are auxiliary control contacts. Two different schematic symbols are created - one to be used to show the heavy-duty motor starter contacts and another symbol to be used for auxiliary contacts. Set up the motor starter contact symbol with attribute PINLIST\_TYPE with a value of "4C" and the auxiliary contact symbol with PINLIST\_TYPE value "4A". In the \_PINLIST database table, encode the pin list information of the part number with type "4" entries but use "4A" and "4C" to differentiate which contact pin combinations are for the auxiliary contacts and which ones are for the starter contacts.

4A,1L,2L;4A,1R,2R;4C,L1,T1;4C,L2,T2;4C,L3,T3

When either symbol is inserted and associated with the parent, AutoCAD Electrical sees the PINLIST\_TYPE value of the symbol. The contact combinations that do not apply to the inserted component type are filtered out. When you insert a N.O. auxiliary motor starter contact (preset with PINLIST\_TYPE attribute value of 4A), you trigger AutoCAD Electrical to pick the next available 4A pin list combination of 1L/2L or 1R/2R. When you insert a N.O. main motor contact symbol (present with PINLIST\_TYPE attribute value of 4C), you trigger AutoCAD Electrical to pick the next available 4C pin list combination (L1/T1, L2/T2, or L3/T3).

### **For multipole terminal block units**

You can also use a type 4 PINLIST assignment to track and control how many schematic terminal symbols can be tied to a given terminal tag-ID, such as when a given terminal strip has a fixed number of terminals. For example, suppose you have a fixed, 6-pole terminal strip unit. The manufacturer code is AB and the catalog part number is 1492-HJ86 with pin markings on the terminal strip identified as 1 through 6. Set up the \_PINLIST database with the AB and 1492-HJ86 combo defining a PINLIST of 4,1;4,2;4,3;4,4;4,5;4,6. In the schematic, insert the first terminal of a 6-pole terminal strip, with a TAG-ID of "TB-1" and do a catalog lookup. Assign the "AB" part number "1492-HJ86." AutoCAD Electrical finds the pin list information and applies it to the first peer terminal symbol as an attribute value. As you insert additional terminals for this TB-1 terminal strip, AutoCAD Electrical tracks what the next available terminal number is (based on the first PINLIST data of the terminal). When you try to insert the seventh terminal for TB-1, you are alerted that there are no more terminals available for this multi-pole terminal strip.

---

**NOTE** This information was previously found in a separate Access file called wd\_pins.mdb. When you use the conversion tools to convert your old .dbf catalog files to the Access file, this file is converted to the \_PINLIST table within the catalog file.

---

### **For convertible contact pin annotations**

Sometimes a relay can have contacts stamped with pin designations for one orientation and another set of pin designations for another orientation. For example, suppose a relay has pin designations "A" and "B" for the contact in its Normally Open (N.O.) orientation. If you flip the convertible contact over, it operates as a Normally Closed (N.C.) contact, and the pin designations of the contact that are now visible are stamped with "C" and "D."

You can set up your type “0” pin list assignment to handle different pin assignments depending on the physical orientation of the contact in the relay body by encoding the symbol PINLIST of the relay coil like:

0, 1A, 1B, 1C, 1D; 0, 2A, 2B, 2C, 2D; 0, 3A, 3B, 3C, 3D; 0, 4A, 4B, 4C, 4D

Each type “0” contact (convertible contact flag) is followed by four pin assignments instead of the normal two. The first two assignments default to the contact when it is inserted as a N.O. contact. If the contact is flipped to N.C., the last two assignments are applied.

### Modify the PINLIST data for four convertible contacts

- 1 Insert a relay coil.
- 2 On the Insert/Edit Component dialog box, Cross-reference section, click NO/NC Setup.
- 3 Enter the PINLIST data (shown previously) in the Pin List field on the Maximum NO/NC counts and/or allowed Pin numbers dialog box.
- 4 Insert a N.O. contact and associate it to the parent coil.  
The pin assignments are “1A” and “1B.”
- 5 Click Schematic tab ► Edit Components panel ► Toggle NO/NC.



- 6 Select the N.O. contact to flip it to a N.C. contact.  
The pin assignments automatically update to “1C” and “1D.”



## Generate reports

There is a lot of flexibility with AutoCAD Electrical reports, which can be run manually or automatically. AutoCAD Electrical extracts multiple fields into each report type. Different reports contain different fields of information. When running a report, you can select which fields to include and which fields to ignore. You can also add your own fields by creating a user-defined attribute support file (.wda) using the User Defined Attributes List tool. Any attributes listed in your User Defined Attributes file are added as available fields to each report. You can strip out some of the field columns of data and create other useful types of reports. For example, run a component report, strip out everything except the TAGNAME, DESC1, DESC2, and DESC3 field columns and you have a legend plate report. If you don't see the specific report that you need, take advantage of the AutoCAD Electrical flexibility and create your own.

There are some features that are common to most of the AutoCAD Electrical reports. You can extract by location or installation values, edit the report, change the report format, post-process the report with your own programs, save the report out to a file, print the report, and put the report on your drawing as a table.

AutoCAD Electrical provides a number of [Schematic](#) on page 1399 and [Panel](#) on page 1427 reports. Reports can be formatted from the Report Generator dialog box or preformatted using Format Files (.set files).

### Modify report templates

You can modify Microsoft Excel report templates "wd\_template.xls" and "wd\_template\_w\_macro.xls" so that the report displays the way you need it to without having to manually modify the report output each time a report is run. You can change the orientation of a template file to open in Landscape mode

rather than Portrait mode by modifying the template and saving it. Run a report and save to an Excel file. When the Excel file is opened, it displays in Landscape mode.

---

**NOTE** If you are using the Export Drawing to Spreadsheet tool, modify the "wd\_xls\_all\_template.txt" template.

---

**TIP** Changing some of the setup on template files (such as changing the text in the first row or the sheet names) can cause the export to fail. Before modifying any template files, save copies so that you can revert back to the original version if necessary.

---

### **Place reports on drawings**

Once you generate a report you can place it on a drawing or drawings by clicking "Put on Drawing" in the Report Generator dialog box. This displays the Table Generation Setup dialog box where you can select options to format the look of the table.

Report tables can be updated once they have been inserted, saving you the trouble of the setup each time. When a report table is inserted, some intelligence is added to the table object so AutoCAD Electrical can determine which report this table was for. There are three items that make a report table unique:

- The report that generated the table (i.e. Bill of Materials, Wire From/To, Component, and so on.)
- The scope of the report (for example, project, active drawing, and so on.)
- The format file (.set file) used to generate the report

If a report is run and a table exists that matches these three items, then instead of inserting a new report table, the existing table objects update with the current information.

If you want to insert a report table that will not be updated, select "Insert New (not updatable)." This inserts a report table without the intelligence so that when you run the same report again, the table is not updated.

### **Break report tables**

You may want to break a report into multiple tables. You can do this from the Table Generation dialog box without having to run the report multiple times or clicking "Put on Drawing" multiple times. You can break the report table by specifying the number of rows per section. If an entry in the report



contains multiple lines of text, such as a Bill of Materials description, each line of text is considered a row. A table will not be broken in the middle of a multi-line entry but the entire entry is moved to the next section.

You can also break a report into sections based on some report fields. This must be selected in the Report Generator dialog box. Different reports may have different Special Breaks available. After you select Special Breaks, and click Put on Drawing, the Apply Special Breaks option is available in the Table Generation Setup dialog box. This option inserts a table object for each section based on the Special Breaks. These multiple table objects (if inserted as updatable) are considered one report table by AutoCAD Electrical and can be updated and edited as one report using the AutoCAD Electrical Edit Component command.

### **Breaking a Report Table across Multiple Drawings**

You can break a report table across multiple drawings if the scope of the report is set to Project and not Active Drawing. In the Table Generation Setup dialog box, once you have defined a break as described above, you can define how many table sections should be placed on each drawing. A blank Sections On Drawing value indicates unlimited sections on the same drawing and you are not prompted for another drawing. Once you enter a Sections On Drawing value, when you reach that value you are prompted for another drawing. If you select a new drawing, you can enter the folder and name for the drawing. Once generated, the drawing is added to the AutoCAD Electrical project. These multiple table objects (if inserted as updatable) are considered one report table by AutoCAD Electrical and can be updated and edited as one report using the AutoCAD Electrical Edit Component command.

### **Wildcard Filtering**

You can filter reports based on wild-carded Installation and Location code assignments. For example, if you mark all of the customer-supplied schematic components and existing equipment with a Location code of "CUST" you can then filter any report using the Location code. To run a report (such as a Bill of Material report) of only the customer-supplied items, select Named Location and enter "CUST" as the Location code in the Location Codes to extract section of the report dialog box and click OK.

You can also run a report of all of the components that are not customer-supplied. To do this, either enter all of the used location codes separated by commas in the Location code edit box of the report dialog box or enter "~CUST" as the Location code in the report dialog box. The tilde (~) prefix causes the report to show everything except components with a Location code of "CUST."

AutoLisp-supported wildcard characters:

<b>Character</b>	<b>Definition</b>
# (pound)	Matches any single numeric digit.
@ (at)	Matches any single alphabetic character.
. (period)	Matches any single non-alphanumeric character.
* (asterisk)	Matches any character sequence, including an empty one and it can be used anywhere in the search pattern: beginning, middle, or end.
? (question mark)	Matches any single character.
~ (tilde)	If it is the first character in the pattern, it matches anything except the pattern.
[...]	Matches any one of the characters enclosed in the brackets.
[~...]	Matches any single characters not enclosed in the brackets.
- (hyphen)	Used inside brackets to specify a range for a single character.
, (comma)	Separates two patterns.
' (reverse quote)	Escapes special characters (reads the next character literally).

### **Table generation setup**

This displays your report as a table on your drawing. Once you select OK from the Table Generation Setup dialog box, your cursor will look like a box with a small "x" in the corner. The box is the size the table will be when generated. This allows easy placement of the table on your active drawing file. To use object snap mode, enter an "S" at the command line and AutoCAD Electrical will flip to a normal AutoCAD pick mode so you can use an object snap.

Click the Put on Drawing button on any of the report generation dialog boxes.

## Table

The available options depend on whether a matching table exists when you click the Put on Drawing button. If there isn't a matching table on the drawing, the Insert New and Insert New (non-updatable) options are available. If a matching table exists on the drawing, the Insert New (non-updatable) and Update Existing options are available.

<b>Insert New</b>	Inserts a new updatable table. If there is an existing table, new (non-updatable) tables are inserted.
<b>Insert New (non-updatable)</b>	Inserts tables with no intelligence.
<b>Update Existing</b>	Updates existing tables. If existing tables do not exist, new updatable tables are inserted.

## Text

Defines the height, color, and line spacing for the text used in the table. To define the text color, click the Text Color box. The standard AutoCAD color selection dialog box opens, displaying the color selections.

The minimum Spacing value is based on the specified text height and the vertical cell margin of the table style. If you change the text height the spacing value automatically recalculates. If it is too small it is changed to the minimum value. If you change the spacing value it is compared to the minimum value. If it is too small an alert displays and the value adjusts to the minimum value.

## Column Labels

Defines whether to include the column heading, the color of title text labels, and the visibility of the column labels.

<b>Include Column Labels</b>	Uses the column headings as the first row of the table.
<b>Label Color</b>	To define the title text color, click the Label Color box. The standard AutoCAD color selection dialog box opens, displaying the color selections.
<b>Show Labels on First Section Only</b>	Indicates to only show the title on the first section of the table, if multiple sections are used. If not selected, the labels will be shown on all table sections.

## **Title**

Defines the table title attributes.

<b>Include time/date</b>	Shows the report's time and date above the table.
<b>Include project info</b>	Shows the project description lines above the table. You select which lines will display in the project description dialog box.
<b>Include title line</b>	Shows the report's title above the table. When the checkbox is active, you may modify the default report title.
<b>Include special break values</b>	Specifies to include special break values for the title line of each section. Special break values will appear on each respective section regardless if the Show Title on First Section Only checkbox is selected.
<b>Title color</b>	Specifies what color to use for the table title. To define the text color, click the Title Color box. The standard AutoCAD color selection dialog box opens, displaying the color selections.
<b>Show Title on First Section Only</b>	Indicates to only show the title on the first section of the table, if multiple sections are used. If not selected, the labels will be shown on all table sections.

## **Layer**

Specifies which layer to place the table on.

## **Column Width**

Specifies the method to use for calculating the width of the columns. You can either have AutoCAD Electrical automatically calculate the column width based on text values for each field or you can define a width for each column. The text will word wrap if the column width is less than the overall length of the text string.

## **Borders**

Specifies whether to display borders around the table. You can display all table borders, a border around just the outside of the table, or not have any borders at all.

### First New Section Placement

Specifies where to place the table in the drawing. You can enter x and y values or pick a point on the screen. The table appears at the specified coordinates once you click the OK button.

### Row Definition

Specifies the number of table rows, the start and end lines, the number of rows for each section, and whether to build the table from the bottom up.

<b>Start Line/End</b>	The starting and ending lines reflect the total number of rows displayed in the Report Generator dialog box. These values default to previously used values on subsequent runs of the report.
<b>Build Up</b>	Creates the table from the bottom to the top; meaning that the last line is created first and the first line is created last. The table title appears at the bottom of the report table when this option is selected.
<b>Apply Special Breaks</b>	Breaks the table sections based upon the selected break criteria. For example, if you select Manufacturer as the Special Break and there are 15 different manufacturers in the report, your report will be broken into 15 sections.
<b>Rows for Each Section/Rows</b>	Specifies the maximum number of rows for the table or section, determining when to split the table.
<b>Force to Maximum Rows</b>	Directs AutoCAD Electrical to add blank lines at the end of a table section if necessary until the number of rows equals the Rows setting. Individual records cannot be split into two separate sections.

### Section Definition

Defines the number of sections on the drawing and the distance between sections on the same drawing. If the Sections value is set to 1, the X-Distance and Y-Distance options are disabled.

<b>Sections</b>	Specifies the maximum number of table sections for this report. A blank value indicates an unlimited number of sections on one drawing.
<b>X-Distance</b>	Specifies the X-distance from the end of one table section to the beginning of the next. The sections are on the same drawing.

**Y-Distance** Specifies the Y-distance from the end of one table section to the beginning of the next. The sections are on the same drawing.

## Optional script file reference

This provides the option to save the report file to a script file. You can set up this script file to automatically know the file name of the report you just created. For AutoCAD 2000 and later, the report's file name can be retrieved using the AutoLISP expression (v1-bb-ref 'FNAM).

Click the Save to File button on a report dialog box (such as Schematic Bill of Materials). Select the report type, click OK, select the file to save, and click Save.

The file location and name for your report is displayed at the top of the dialog box.

**Run Script** Passes the report file to a script file. This provides a link to post-processing the data or automatically passing it on to another application.

**Close - no script** Closes the dialog box without creating a script file.

## Script file options reference

Displays if the report file was created and saved. The report filename and location are displayed in the title bar of the dialog box. You can execute a script file and passes the report filename to it. The filename is carried in an AutoLISP variable called FNAM.

Click the Save to File button on a report dialog box (such as Schematic Bill of Materials). Select the report type, click OK, select the file to save, and click Save. In the Optional Script File dialog box, select Run Script.

## Edit report

Use this utility to modify a report before you insert it on to your drawing as a ruled text table.

Click the Edit Mode button on any of the report dialog boxes (such as Schematic Bill of Materials).

---

**NOTE** Different options are available depending on which type of report you are editing.

---

### **New Lines**

Indicates to add new lines above or below the selected line, or as a sub-assembly of the selected line.

- **Add from Catalog:** Opens a subdialog box for selecting which catalog lookup table to open. From this catalog table, you can select a part to add to the report.
- **Add New:** Creates a new report line entry. Enter the values in the input boxes and click OK.
- **Add Copy:** Creates a copy of the selected line entry. Modify the values in the input boxes and click OK.

### **Edit or Delete lines**

- **Edit:** Opens a subdialog box for editing the values for the selected line.
- **Delete:** Removes the selected line from the report.  
If you do not select all of the lines that make up a single entry, AutoCAD Electrical automatically deletes all the report lines that make up that entire entry. However, if the report contains sub-assembly items, they are not deleted when the main entry is deleted.

### **Re-order lines**

Re-orders the lines with the Sort, Move Up, Move Down, Move to Top, and Move to Bottom buttons.

- **Move Up:** Moves the currently selected line(s) up one place in the report.
- **Move Down:** Moves the currently selected line(s) down one place in the report.
- **Move to Top:** Moves the currently selected line(s) to the top of the report.
- **Move to Bottom:** Moves the currently selected line(s) to the bottom of the report.
- **Smart Swap:** Swaps "\*1" with "\*2" values in all selected lines. For example, in the Wire From/To report there may be field names LOC1 and LOC2. LOC1 is the location code for the component at one end of the wire and LOC2 is the location code for the component at the other end. This feature swaps the values of these fields.

## **Report generator**

Displays the results of the report generation. The dialog box options that are available depend on which report you are creating.

### Schematic Reports

 **Ribbon:** Reports tab ► Schematic panel ► Reports.

 **Toolbar:** Main Electrical 2

**Menu:** Projects ► Reports ► Schematic Reports

**Command entry:** AESCHEMATICREPORT

Specify whether to process the project, the active drawing, or selected components, and click OK

### Panel Reports

 **Ribbon:** Reports tab ► Panel panel ► Reports.

 **Toolbar:** Panel Layout

**Menu:** Projects ► Reports ► Panel Reports

**Command entry:** AEPANELREPORT

Specify whether to process the project, the active drawing, or selected components, and click OK

### Header

Displays the selected items at the top of each section in the report.

- |                           |   |
|---------------------------|---|
| <b>Add</b>                | Displays the header information inside the report. Select to add the time/date, a title line, project lines, or column labels.                    |
| <b>First Section Only</b> | Displays the selected header item at the top of the first section only. The header information is no longer displayed at the top of each section. |



## Breaks

Controls how the report breaks across multiple pages. Only one check box can be selected at a time. Specify whether to add page breaks or special breaks to the report.

<b>Add page breaks</b>	Breaks the report at the 58th line.
<b>Special breaks</b>	Specifies the value that controls the section break. You can break the report into sections based on the special break selected from the list. The list displays the report-specific content to apply to the special break. For example, selecting Wire Layer displays the wire label records in different sections based on the wire layer data.
<b>Add special break values to header</b>	Adds the special break value to the header. For example, if you select a special break of Installation/Location, the values provided for these devices in the schematic are displayed in the report section header.

## Suppress subcatalog entries

(for Component Report only) The component report displays all components and their related catalog numbers. A component can have one or many catalog numbers associated to it based upon whether or it is set up with subcatalog numbers or if you choose to assign multiple BOM items to the component. This removes the extra catalog numbers from the report and displays only the primary catalog number from the Insert/Edit Component dialog box.

## Pin chart

(for Connector Plug Report only)

The Connector Plug report displays the wiring information associated to a pin symbol in the form of a chart based upon a similar Component tag. Selecting "On" displays another dialog box to set up the chart and yields just the specified information into the report generator for printing, saving to a file, or placing in a table on the drawing.

<b>Tag Name</b>	Displays all component tag names in the report.
<b>Remove duplicated pin numbers</b>	Eliminates any duplicate pin numbers for the selected plug from the report.

**Left Side / Right Side**

Displays the wiring information from the left or right side of the pin symbols. This displays what is connected to the pin and the wiring information.

**Fill In Missing Pin Numbers**

Identifies additional pin numbering not defined in the schematic for spare pin connections. For example, the connector may have used four out of nine pins in the schematic and those are the connections that are being reported. You can then display the five spare pin connections by selecting this check box and identifying the first pin number as 1 and the last as 9. Label for spares displays a text string under the wire number column in the report.

**Internal/external codes left/right**

(for Terminal Plan Report only) Allows the Terminal Plan report to take advantage of terminals that have the optional "I" (Internal) and "E" (external) codes on the wire connection. With this check box selected, you can select from the radio buttons below it to sort within an entry. You can show all of the Internal or External connections on the left or on the right of the wire connection.

**Squeeze**

Specifies whether to reduce the width of the report. Select 1 for maximum squeezing and 3 for minimum squeezing.

**Add blanks between entries**

Adds a blank line between report entries.

**Insert as Terminal Strip**

(for Panel Terminal Strip Report only) Opens the Panel Terminal Strip Graphical Report - Parameters dialog box for defining a graphical representation of the terminal strip to place on the active drawing file.

**Plug/Male side - Jack/Female side - Show All**

(for Connector Details Report only) These three radio buttons work with the Type attribute value of either P or J for Plug (male) or Jack (female). When the pin symbol is created you can define a Type attribute that defines these

characteristics. Then when reporting you can select Plug or Jack to filter the overall report (or you can choose to show all).

### Sort

Sorts the report. You can specify four sorts to perform on the list.

### User Post

Sets up options for running a post-process report before saving the report to a file or inserting as a table onto your drawing. AutoCAD Electrical supports calling a LISP file that can be customized to meet any post-processing needs for a report. Each LISP file also has an associated dialog definition .dcl file with the same name. When you click User Post, the dialog box displays the available options. Select an option and the lisp routine runs a function against the data and returns to the Report Generator Window.

The LISP routine can be modified to meet your needs. Use these tables to determine the name of the .lsp and .dcl files for a report.

---

**NOTE** Example User Post files are not supplied for all reports.

---

<b>Schematic Report</b>	<b>User post file name for .lsp and .dcl</b>
Bill of Materials - Normal Tallied Format	BOM
Bill of Materials - Normal Tallied Format (Group by Installation/Location)	BOM_LOC
Bill of Materials - Display in Tallied Purchase List Format	PUR_BOM
Bill of Materials - Display in "By Tag" Format	TAG_BOM
Missing Bill of Material	NOCAT
Component	COMP
Wire From/To	WIREFRM2
Component Wire List	WIRECON
Connector Plug	PJCON
PLC I/O Address and Descriptions	PLC

<b>Schematic Report</b>	<b>User post file name for .lsp and .dcl</b>
PLC I/O Component Connection	PLCCON
PLC Modules Used So Far	PLC_USED
Terminal Numbers	TERM
Terminal Plan	TERMPAN
Connector Summary	QPINRPT
Connector Detail	PINRPT
Cable Summary	CBL
Cable From/To	CBLCON
Wire Label	WIRELABEL
<b>Panel Report</b>	<b>User post file name for .lsp and .dcl</b>
Bill of Materials - Normal Tallied Format	BOMPANL
Bill of Materials - Normal Tallied Format (Group by Installation/Location)	PBOM_LOC
Bill of Materials - Display in Tallied Purchase List Format	PUR_PBOM
Bill of Materials - Display in "By Tag" Format	TAG_PBOM
Component	PNLCOMP
Nameplate	PNL_NP
Wire Connection	PNLWCON
Component Exception	PNLXCPT
Terminal Exception	PNLTXCPT
Wire Annotation Exception	PNLWANNO

## Panel Report

User post file name for .lsp and .dcl

Missing Level/Sequence Assignments

LEVBLNK

### Display Setup

(for Wire Label report only) Sets up options for label quantity, horizontal or vertical arrangement of data, display selection of wire labels and cable labels, and total number of columns for displaying the report.

<b>Display Wire Label</b>	Displays the wire label for all wires in the specified format.
<b>Display Cable Label</b>	Displays the cable labels in the specified format.
<b>Label Arrangement</b>	Arranges the wire label horizontally or vertically across the columns.
<b>Label Quantity per Connection</b>	Specifies the quantity of wire labels or cable labels. Wire labels are generated for every wire connection while cable labels are generated once for every cable.
<b>Number of Columns to Display</b>	Arranges the wire labels in the specified number of columns.

### Change Report Format

Changes what data fields are reported and the order in which they appear.

(for Wire Label report only) There are two categories that you can change the report format for: wire label or cable label. Once you modify the report format, you can save it for future use. The wire and cable label formats are stored in the same file.

### Surf

Surfs to the offending symbols. This is generally used for the Missing Level/Sequence Assignments and Wire Annotation Exception reports.

### Edit Mode/Edit Wire Label/Edit Cable Label

Modifies the report before you insert it to your drawing. You can move data up or down in the report, add lines from a catalog, and delete lines.

### Put on Drawing

(Not applicable for Wire Label reports) Opens the Table Generation Setup dialog box for specifying how to display your report as a table on your drawing.

---

**NOTE** Tables should be placed on drawings that are part of the active project only.

---

Once wire label reports are placed on the drawing in table format they are not editable using the Edit Component tool. You must use the AutoCAD table edit command to edit the table.

### Save to File

Saves the report to a file. Select the type of output file from the Save Report to File dialog box. You can define multiple file outputs. Choose from: ASCII report, Comma Delimited, Excel spreadsheet, Access database, and XML format.

---

**NOTE** Depending on the file type, you may have the ability to include the project's LINEx values. These are the values in the 24 description lines entered for the project.

---

### Print

Prints the report. Select the printer, print range, and number of copies.

## Conduit marker data fields to display

Changes what data fields are reported and the order in which they appear.

 **Ribbon:** Panel tab ► Conduit Tools panel ► Conduit Reports drop-down

►  Conduit Report.

 **Toolbar:** Conduit Reports

 **Menu:** Panel Layout ► Conduit Marker Tools ► Conduit Marker Report

 **Command entry:** AECONDUITMARKERRPT

Run the report and click Change Report Format on the Report Generator dialog box.

### Available Fields

Lists the available fields for formatting the report (including user-defined attributes). Select a field from the list to transfer it into the Fields to Report list.

<b>Fields to Report</b>	Lists the fields to display in the report.
<b>Remove/Remove All</b>	Removes the selected field or all fields from the Fields to Report list.
<b>Move Up</b>	Moves the selected field up one spot in the Fields to Report list.
<b>Move Down</b>	Moves the selected field down one spot in the Fields to Report list.
<b>Change field name/justification</b>	Specifies the vertical and horizontal justification (Top Left, Middle Center, Bottom Right) of any column and the column label (default is Top Left). The vertical portion of the justification (Top, Middle, Bottom) is only used for the Put on Drawing report feature. For example, if you select "Top Right" the report is right-justified during the display, printing and when saved to a file (the "top" portion is ignored). If you put the report on the drawing, the report justification is top right.

#### **Available Fields**



<b>TAG</b>	Component tag name
<b>SIZE</b>	Conduit size (diameter)
<b>MFG</b>	Manufacturer or vendor name (i.e. Siemens)
<b>CAT</b>	Catalog part number assignment
<b>ASSYCODE</b>	Optional assembly code value used in catalog lookup query to get part number groups
<b>WIRENO</b>	Wire number
<b>WIRELAY</b>	Wire layer
<b>WIREDISC</b>	Wire type description
<b>WIREDIA</b>	Wire gauge or diameter
<b>SPARES</b>	Type of spare or unused wires

SP/CNT	Count of spare or unused wires
DESC1-2	Description attribute values 1-2
HDL	Entity handle number
SH	Sheet - the %S value
LEN	Length (calculated wire length)
INST1	"From" device's installation code (must end with "1")
LOC1	"From" device's location code (must end with "1")
CMP1	"From" device's component tag ID (must end with "1")
PIN1	"From" device's wire connection terminal number (must end with "1")
INST2	"To" device's installation code (must end with "2")
LOC2	"To" device's location code (must end with "2")
CMP2	"To" device's component tag ID (must end with "2")
PIN2	"To" device's wire connection terminal number (must end with "2")
CBL	Cable tag
CBLWC	Cable wire or cable core color

## Drawing list data fields to display

Changes what data fields are reported and the order in which they appear.

 **Ribbon:** Project tab ► Project Tools panel ► Manager. 

 **Toolbar:** Main Electrical 2 

 **Menu:** Projects ► Project ► Project Manager



 **Command entry: AEPROJECT**

In the Project Manager, right-click the project name and select Drawing List Report. Run the report and click Change Report Format on the Report Generator dialog box.

<b>Available Fields</b>	Lists the available fields for formatting the report (including user-defined attributes). Select a field from the list to transfer it into the Fields to Report list.
<b>Fields to Report</b>	Lists the fields to display in the report.
<b>Remove/Remove All</b>	Removes the selected field or all fields from the Fields to Report list.
<b>Move Up</b>	Moves the selected field up one spot in the Fields to Report list.
<b>Move Down</b>	Moves the selected field down one spot in the Fields to Report list.
<b>Change field name/justification</b>	Specifies the vertical and horizontal justification (Top Left, Middle Center, Bottom Right) of any column and the column label (default is Top Left). The vertical portion of the justification (Top, Middle, Bottom) is only used for the Put on Drawing report feature. For example, if you select "Top Right" the report is right-justified during the display, printing and when saved to a file (the "top" portion is ignored). If you put the report on the drawing, the report justification is top right.

### Available Fields

---

**NOTE** Additional fields may display if the drawing or project is set up with a title block association. The title block association can be made either through the Acade\_title block with the WD\_TB attribute or if there is a .WDT file (can be project-specific or just a default one).

---

<b>FILENAME</b>	AutoCAD drawing file name (.dwg)
<b>SH</b>	Sheet - the %S value
<b>SHDWGNAM</b>	Drawing name - the %D value

SEC	Drawing SEC assignment
SUBSEC	Drawing SUBSEC assignment
DWGDESC	Drawing one-line description text
FULLFILENAME	AutoCAD drawing file name (.dwg) with complete path

## Cable insert/edit data fields to display

Changes what data fields are reported and the order in which they appear.

 **Ribbon:** Schematic tab ► Insert Wires/Wire Numbers panel ► Cable

Markers drop-down ► Multiple Cable Markers.

 **Toolbar:** Cable Markers

 **Menu:** Wires ► Cables ► Multiple Cable Markers

 **Command entry:** AEMULTICABLE

Run the report. Select the location codes for the report and click Change Format on the Cable Insert/Edit dialog box.

<b>Available Fields</b>	Lists the available fields for formatting the report (including user-defined attributes). Select a field from the list to transfer it into the Fields to Report list.
<b>Fields to Report</b>	Lists the fields to display in the report.
<b>Remove/Remove All</b>	Removes the selected field or all fields from the Fields to Report list.
<b>Move Up</b>	Moves the selected field up one spot in the Fields to Report list.
<b>Move Down</b>	Moves the selected field down one spot in the Fields to Report list.
<b>Change field name/justification</b>	Specifies the vertical and horizontal justification (Top Left, Middle Center, Bottom Right) of any column and the column label (default is Top Left). The vertical portion of

the justification (Top, Middle, Bottom) is only used for the Put on Drawing report feature. For example, if you select "Top Right" the report is right-justified during the display, printing and when saved to a file (the "top" portion is ignored). If you put the report on the drawing, the report justification is top right.

### Available Fields

<b>WIRENO</b>	Wire number
<b>LOC1</b>	"From" device's location code (must end with "1")
<b>CMP1</b>	"From" device's component tag ID (must end with "1")
<b>PIN1</b>	"From" device's wire connection terminal pin number (must end with "1")
<b>LOC2</b>	"To" device's location code (must end with "2")
<b>CMP2</b>	"To" device's component tag ID (must end with "2")
<b>PIN2</b>	"To" device's wire connection terminal pin number (must end with "2")
<b>WLAY1</b>	Wire layer "From" device (must end with "1")
<b>WLAY2</b>	Wire layer "To" device (must end with "2")
<b>REF1</b>	Line or grid reference location for "From" device (must end with "1")
<b>REF2</b>	Line or grid reference location for "To" device (must end with "2")
<b>SH1</b>	Sheet assignment for "From" device (must end with "1")
<b>SH2</b>	Sheet assignment for "To" device (must end with "2")
<b>CBL</b>	Cable tag
<b>CBLWC</b>	Cable wire or cable core color
<b>CBLLOC</b>	Cable location attribute value

<b>CBLMFG</b>	Cable manufacturer attribute value
<b>CBLCAT</b>	Cable catalog part number
<b>CBLASMB</b>	Cable ASSYCODE assignment
<b>DESC1CBL - DESC3CBL</b>	Cable description attribute values 1 - 3
<b>CBLP1C2</b>	Cable parent or child (parent = 1, child = 2)
<b>CMP:PIN1</b>	"From" device's component tag and component terminal pin number
<b>CMP:PIN2</b>	"To" device's component tag and component terminal pin number
<b>SEC1</b>	"From" device's drawing section assignment (must end with "1")
<b>SUB1</b>	"From" device's drawing sub-section assignment (must end with "1")
<b>SEC2</b>	"To" device's drawing section assignment (must end with "2")
<b>SUB2</b>	"To" device's drawing sub-section assignment (must end with "2")
<b>INST1</b>	"From" device's installation code (must end with "1")
<b>INST2</b>	"To" device's installation code (must end with "2")
<b>IECCMP1</b>	"From" device's IEC tag name (must end with "1")
<b>IECCMP2</b>	"To" device's IEC tag name (must end with "2")
<b>PD1</b>	"From" device's wire connection TERMDESC value (must end with "1")
<b>PD2</b>	"To" device's wire connection TERMDESC value (must end with "2")
<b>SEQ1</b>	"From" device's wire connection sequence value (must end with "1")
<b>SEQ2</b>	"To" device's wire connection sequence value (must end with "2")
<b>PNLWDLEV1</b>	"From" device's panel equivalent level (WDLEV) value (must end with "1")

<b>PNLWDLEV2</b>	"To" device's panel equivalent level (WDLEV) value (must end with "2")
<b>CMPHDL1</b>	"From" device's entity handle value (must end with "1")
<b>CMPHDL2</b>	"To" device's entity handle value (must end with "2")
<b>DWGIX1</b>	"From" device's drawing DWGIX value as listed in FILETIME table of project scratch database (must end with "1")
<b>DWGIX2</b>	"To" device's drawing DWGIX value as listed in FILETIME table of project scratch database (must end with "2")
<b>DWGNAM1</b>	"From" device's drawing %D value (must end with "1")
<b>DWGNAM2</b>	"To" device's drawing %D value (must end with "2")
<b>CBLHDL</b>	Cable entity's handle value
<b>CBLINST</b>	Cable installation assignment
<b>CBLDWGIX</b>	Cable's drawing DWGIX value as listed in FILETIME table of project scratch database
<b>WIREHDL1</b>	"From" device's connected wire line entity handle value (must end with "1")
<b>WIREHDL2</b>	"To" device's connected wire line entity handle value (must end with "2")
<b>XDIR1</b>	"From" device's wire connection point direction - i.e. 4 = connects from left (must end with "1")
<b>XDIR2</b>	"To" device's wire connection point direction - i.e. 2 = connects from above (must end with "2")
<b>PNLX1</b>	"From" wire connection's physical X-coordinate value (must end with "1")
<b>PNLY1</b>	"From" wire connection's physical Y-coordinate value (must end with "1")

PNLZ1	"From" wire connection's physical Z-coordinate value (must end with "1")
PNLXDIR1	Panel wire "From" connection point's direction - i.e. 4 = connects from left, 1 = right, 2 = above, 8 = below (must end with "1")
PNLX2	"To" wire connection's physical X-coordinate value (must end with "2")
PNLY2	"To" wire connection's physical Y-coordinate value (must end with "2")
PNLZ2	"To" wire connection's physical Z-coordinate value (must end with "2")
PNLXDIR2	Panel wire "To" connection point's direction - i.e. 4 = connects from left, 1 = right, 2 = above, 8 = below (must end with "2")
CLEN	Panel layout calculated wire length

## Panel bill of material data fields to report

Changes what data fields are reported and the order in which they appear.

 **Ribbon:** Reports tab > Panel panel > Reports.



 **Toolbar:** Panel Layout



 **Menu:** Projects > Reports > Panel Reports

 **Command entry:** AEPANELREPORT

Select Bill of Material from the report list. Run the report and click Change Report Format on the Report Generator dialog box.

<b>Available Fields</b>	Lists the available fields for formatting the report (including user-defined attributes). Select a field from the list to transfer it into the Fields to Report list.
<b>Fields to Report</b>	Lists the fields to display in the report.

<b>Remove/Remove All</b>	Removes the selected field or all fields from the Fields to Report list.
<b>Move Up</b>	Moves the selected field up one spot in the Fields to Report list.
<b>Move Down</b>	Moves the selected field down one spot in the Fields to Report list.
<b>Change field name/justification</b>	Specifies the vertical and horizontal justification (Top Left, Middle Center, Bottom Right) of any column and the column label (default is Top Left). The vertical portion of the justification (Top, Middle, Bottom) is only used for the Put on Drawing report feature. For example, if you select "Top Right" the report is right-justified during the display, printing and when saved to a file (the "top" portion is ignored). If you put the report on the drawing, the report justification is top right.

### Available Fields

The fields that are available depend on the report options you selected when running the report.

<b>ITEM</b>	Item number assignment
<b>N/A</b>	Not applicable or not used
<b>QTY</b>	Quantity
<b>SUB</b>	Subassembly quantity
<b>CATALOG</b>	Catalog part number assignment
<b>MFG</b>	Manufacturer or vendor name (i.e. Siemens)
<b>ASSYCODE</b>	Optional assembly code value used in catalog lookup query to get part number groups
<b>DESCRIPTION</b>	Multi-line description column
<b>DESC</b>	General description line of text

<b>QUERY2</b>	2nd query field (middle pulldown on Catalog Lookup dialog box)
<b>QUERY3</b>	3rd query field (right-hand pulldown on Catalog Lookup dialog box)
<b>MISC1-2</b>	Catalog lookup data field
<b>USER1-3</b>	User field in catalog lookup database
<b>TABNAM</b>	Catalog Database (vendor database) table name
<b>TAGS</b>	Component tag names
<b>HDL</b>	Entity handle number
<b>DWGIX</b>	"From" device's drawing DWGIX value as listed in FILETIME table of project scratch database

## Panel component exception data fields to report

Changes what data fields are reported and the order in which they appear.

 **Ribbon:** Reports tab ► Panel panel ► Reports. 

 **Toolbar:** Panel Layout 

 **Menu:** Projects ► Reports ► Panel Reports

 **Command entry:** AEPANELREPORT

Select Component Exception from the report list. Run the report and click Change Report Format on the Report Generator dialog box.

<b>Available Fields</b>	Lists the available fields for formatting the report (including user-defined attributes). Select a field from the list to transfer it into the Fields to Report list.
<b>Fields to Report</b>	Lists the fields to display in the report.
<b>Remove/Remove All</b>	Removes the selected field or all fields from the Fields to Report list.



<b>Move Up</b>	Moves the selected field up one spot in the Fields to Report list.
<b>Move Down</b>	Moves the selected field down one spot in the Fields to Report list.
<b>Change field name/justification</b>	Specifies the vertical and horizontal justification (Top Left, Middle Center, Bottom Right) of any column and the column label (default is Top Left). The vertical portion of the justification (Top, Middle, Bottom) is only used for the Put on Drawing report feature. For example, if you select "Top Right" the report is right-justified during the display, printing and when saved to a file (the "top" portion is ignored). If you put the report on the drawing, the report justification is top right.

### Available Fields

<b>TAGNAME</b>	Tag ID value (attributes "TAG", "TAG1", "TAGSTRIP", "P_TAG1")
<b>INST</b>	Installation attribute value
<b>LOC</b>	Location attribute value
<b>COMMENT</b>	Comment or explanation of issue
<b>PNL</b>	Value of the problem area on the footprint component; shows the value on the panel layout (i.e. If the Comment is "Mismatch LOC", the LOC attribute is different between the Panel Layout and Schematic components).
<b>SCHEM</b>	Value of the problem area on the component; shows the value on the schematic drawing (i.e. If the Comment is "Mismatch LOC", the LOC attribute is different between the Panel Layout and Schematic components).
<b>HDL</b>	Entity handle number
<b>SH</b>	Sheet - the %S value
<b>SHDWGNAM</b>	Drawing name - the %D value

**FULLFILENAME** AutoCAD drawing file name (.dwg) with complete path

**FILENAME** AutoCAD drawing file name (.dwg)

## Panel component data fields to report

Changes what data fields are reported and the order in which they appear.

 **Ribbon:** Reports tab ► Panel panel ► Reports. 

 **Toolbar:** Panel Layout   
 **Menu:** Projects ► Reports ► Panel Reports

 **Command entry:** AEPANELREPORT

Select Component from the report list. Run the report and click Change Report Format on the Report Generator dialog box.

**Available Fields** Lists the available fields for formatting the report (including user-defined attributes). Select a field from the list to transfer it into the Fields to Report list.

**Fields to Report** Lists the fields to display in the report.

**Remove/Remove All** Removes the selected field or all fields from the Fields to Report list.

**Move Up** Moves the selected field up one spot in the Fields to Report list.

**Move Down** Moves the selected field down one spot in the Fields to Report list.

**Change field name/justification** Specifies the vertical and horizontal justification (Top Left, Middle Center, Bottom Right) of any column and the column label (default is Top Left). The vertical portion of the justification (Top, Middle, Bottom) is only used for the Put on Drawing report feature. For example, if you select "Top Right" the report is right-justified during the display, printing and when saved to a file (the "top" portion is ig-

nored). If you put the report on the drawing, the report justification is top right.

### Available Fields

<b>ITEM</b>	Item number assignment
<b>TAGNAME</b>	Tag ID value (attributes "TAG", "TAG1", "TAGSTRIP", "P_TAG1")
<b>CNT</b>	Count
<b>UNITS</b>	Units of measurement (i.e. AMPS, VOLTS, mA)
<b>SUBQTY</b>	Sub-quantity
<b>MFG</b>	Manufacturer or vendor name (i.e. Siemens)
<b>CAT</b>	Catalog part number assignment
<b>DESC1-3</b>	Description attribute values 1-3
<b>REF</b>	Line reference or X-Y grid reference or X-Zone reference
<b>INST</b>	Installation attribute value
<b>LOC</b>	Location attribute value
<b>MOUNT</b>	Mount attribute value; panel layout optional attribute for user-defined "panel mounting" assignment
<b>GROUP</b>	GROUPWITH attribute value; panel layout optional attribute for user-defined "group with" assignment
<b>RATING1-12</b>	Rating 1 - 12 attribute values
<b>CATDESC</b>	Catalog one-line description text
<b>QUERY1</b>	QUERY1 field pulled from catalog lookup and formatted into output report
<b>QUERY2</b>	2nd query field (middle pulldown on Catalog Lookup dialog box)
<b>MISC1-2</b>	Catalog lookup data field

<b>USER1-3</b>	User field in catalog lookup database
<b>P1C2</b>	parent = 1, child = 2
<b>WDBLKNAM</b>	Related to the name of the component's catalog lookup table
<b>BLOCK</b>	Block name
<b>HDL</b>	Entity handle number
<b>CATEGORY</b>	Type of component (J = plug-jack connector, P = PLC I/O, C = cable marker)
<b>ASSYCODE</b>	Optional assembly code value used in catalog lookup query to get part number groups
<b>SH</b>	Sheet - the %S value
<b>SHDWGNAM</b>	Drawing name - the %D value
<b>SEC</b>	Drawing section assignment
<b>SUBSEC</b>	Drawing sub-section assignment
<b>FAMILY</b>	Component family
<b>WDTAGALT</b>	Related tag ID of device on alternate drawing type
<b>WDTYPE</b>	Alternate type of symbol (for example, "PN" for pneumatic, "HY" for hydraulic)
<b>FILENAME</b>	AutoCAD drawing file name (.dwg)

## **Panel missing level/sequence assignments data fields to report**

Changes what data fields are reported and the order in which they appear.

 **Ribbon:** Reports tab ► Panel panel ► Reports.





 **Toolbar:** Panel Layout

 **Menu:** Projects ► Reports ► Panel Reports

 **Command entry:** AEPANELREPORT

Select Missing Level/Sequence Assignments from the report list. Run the report and click Change Report Format on the Report Generator dialog box.

<b>Available Fields</b>	Lists the available fields for formatting the report (including user-defined attributes). Select a field from the list to transfer it into the Fields to Report list.
<b>Fields to Report</b>	Lists the fields to display in the report.
<b>Remove/Remove All</b>	Removes the selected field or all fields from the Fields to Report list.
<b>Move Up</b>	Moves the selected field up one spot in the Fields to Report list.
<b>Move Down</b>	Moves the selected field down one spot in the Fields to Report list.
<b>Change field name/justification</b>	Specifies the vertical and horizontal justification (Top Left, Middle Center, Bottom Right) of any column and the column label (default is Top Left). The vertical portion of the justification (Top, Middle, Bottom) is only used for the Put on Drawing report feature. For example, if you select "Top Right" the report is right-justified during the display, printing and when saved to a file (the "top" portion is ignored). If you put the report on the drawing, the report justification is top right.

#### **Available Fields**



<b>TAGNAME</b>	Tag ID value (attributes "TAG", "TAG1", "TAGSTRIP", "P_TAG1")
<b>INST</b>	Installation attribute value
<b>LOC</b>	Location attribute value

<b>MOUNT</b>	Mount attribute value; panel layout optional attribute for user-defined "panel mounting" assignment
<b>GROUP</b>	GROUPWITH attribute value; panel layout optional attribute for user-defined "group with" assignment
<b>HDL</b>	Entity handle number
<b>CATEGORY</b>	Type of component (J = plug-jack connector, P = PLC I/O, C = cable marker)
<b>DESC1-3</b>	Description attribute values 1-3
<b>SH</b>	Sheet - the %S value
<b>SHDWGNAM</b>	Drawing name - the %D value
<b>FILENAME</b>	AutoCAD drawing file name (.dwg)

## Panel wire annotation exception data fields to report

Changes what data fields are reported and the order in which they appear.

 **Ribbon:** Reports tab > Panel panel > Reports. 

 **Toolbar:** Panel Layout 

 **Menu:** Projects > Reports > Panel Reports

 **Command entry:** AEPANELREPORT

Select Wire Annotation Exception from the report list. Run the report and click Change Report Format on the Report Generator dialog box.

<b>Available Fields</b>	Lists the available fields for formatting the report (including user-defined attributes). Select a field from the list to transfer it into the Fields to Report list.
<b>Fields to Report</b>	Lists the fields to display in the report.

<b>Remove/Remove All</b>	Removes the selected field or all fields from the Fields to Report list.
<b>Move Up</b>	Moves the selected field up one spot in the Fields to Report list.
<b>Move Down</b>	Moves the selected field down one spot in the Fields to Report list.
<b>Change field name/justification</b>	Specifies the vertical and horizontal justification (Top Left, Middle Center, Bottom Right) of any column and the column label (default is Top Left). The vertical portion of the justification (Top, Middle, Bottom) is only used for the Put on Drawing report feature. For example, if you select "Top Right" the report is right-justified during the display, printing and when saved to a file (the "top" portion is ignored). If you put the report on the drawing, the report justification is top right.

### Available Fields



<b>TAGNAME</b>	Tag ID value (attributes "TAG", "TAG1", "TAGSTRIP", "P_TAG1")
<b>PIN</b>	Wire connection terminal pin number
<b>WIRENO</b>	Wire number
<b>WTYPE</b>	Alternate type of symbol (for example, "PN" for pneumatic, "HY" for hydraulic)
<b>INST</b>	Installation attribute value
<b>LOC</b>	Location attribute value
<b>MOUNT</b>	Mount attribute value; panel layout optional attribute for user-defined "panel mounting" assignment
<b>GROUP</b>	GROUPWITH attribute value; panel layout optional attribute for user-defined "group with" assignment
<b>END1</b>	Component and connection information on one end of wire (must end with "1")

<b>END2</b>	Component and connection information on one end of wire (must end with "2")
<b>BLKNAME</b>	WDBLKNAM attribute value used for the linking of symbols to tables in the Default CAT database
<b>DWGIX</b>	"From" device's drawing DWGIX value as listed in FILETIME table of project scratch database
<b>HDL</b>	Entity handle number
<b>CATEGORY</b>	Type of component (J = plug-jack connector, P = PLC I/O, C = cable marker, FP = Panel Footprint, FPT = terminal footprint)
<b>PDESC</b>	Wire connection point description attribute value
<b>SFX</b>	Values of R or L; used for terminal block symbols where we identify the wire annotation attributes with an R or L for Right or Left of the symbol
<b>SH</b>	Sheet - the %S value
<b>SHDWGNAM</b>	Drawing name - the %D value
<b>CBL</b>	Cable tag
<b>TEXT</b>	Wire annotation text

## Panel nameplate data fields to report

Changes what data fields are reported and the order in which they appear.

 **Ribbon:** Reports tab > Panel panel > Reports. 

 **Toolbar:** Panel Layout 

 **Menu:** Projects > Reports > Panel Reports

 **Command entry:** AEPANELREPORT



Select Nameplate from the report list. Run the report and click Change Report Format on the Report Generator dialog box.

<b>Available Fields</b>	Lists the available fields for formatting the report (including user-defined attributes). Select a field from the list to transfer it into the Fields to Report list.
<b>Fields to Report</b>	Lists the fields to display in the report.
<b>Remove/Remove All</b>	Removes the selected field or all fields from the Fields to Report list.
<b>Move Up</b>	Moves the selected field up one spot in the Fields to Report list.
<b>Move Down</b>	Moves the selected field down one spot in the Fields to Report list.
<b>Change field name/justification</b>	Specifies the vertical and horizontal justification (Top Left, Middle Center, Bottom Right) of any column and the column label (default is Top Left). The vertical portion of the justification (Top, Middle, Bottom) is only used for the Put on Drawing report feature. For example, if you select "Top Right" the report is right-justified during the display, printing and when saved to a file (the "top" portion is ignored). If you put the report on the drawing, the report justification is top right.

### Available Fields

<b>TAGNAME</b>	Tag ID value (attributes "TAG", "TAG1", "TAGSTRIP", "P_TAG1")
<b>DESC1-3</b>	Description attribute values 1-3
<b>MFG</b>	Manufacturer or vendor name (i.e. Siemens)
<b>CATALOG</b>	Catalog part number assignment
<b>BLKNAME</b>	Block name
<b>WITH</b>	Nameplate tied in with this footprint device tag
<b>LOC</b>	Location attribute value

<b>MOUNT</b>	Mount attribute value; panel layout optional attribute for user-defined "panel mounting" assignment
<b>GROUP</b>	GROUPWITH attribute value; panel layout optional attribute for user-defined "group with" assignment
<b>INST</b>	Installation attribute value
<b>SH</b>	Sheet - the %S value
<b>SHDWGNAM</b>	Drawing name - the %D value
<b>ITEM</b>	Item number assignment
<b>RATING1-12</b>	Rating 1 - 12 attribute values
<b>POS1-12</b>	Switch position description text (1 - 12)
<b>HDL</b>	Entity handle number
<b>DWGIX</b>	"From" device's drawing DWGIX value as listed in FILETIME table of project scratch database

## Panel terminal exception data fields to report

Changes what data fields are reported and the order in which they appear.

 **Ribbon:** Reports tab ► Panel panel ► Reports. 

 **Toolbar:** Panel Layout

 **Menu:** Projects ► Reports ► Panel Reports

 **Command entry:** AEPANELREPORT

Select Terminal Exception from the report list. Run the report and click Change Report Format on the Report Generator dialog box.

### Available Fields

Lists the available fields for formatting the report (including user-defined attributes). Select a field from the list to transfer it into the Fields to Report list.

<b>Fields to Report</b>	Lists the fields to display in the report.
<b>Remove/Remove All</b>	Removes the selected field or all fields from the Fields to Report list.
<b>Move Up</b>	Moves the selected field up one spot in the Fields to Report list.
<b>Move Down</b>	Moves the selected field down one spot in the Fields to Report list.
<b>Change field name/justification</b>	Specifies the vertical and horizontal justification (Top Left, Middle Center, Bottom Right) of any column and the column label (default is Top Left). The vertical portion of the justification (Top, Middle, Bottom) is only used for the Put on Drawing report feature. For example, if you select "Top Right" the report is right-justified during the display, printing and when saved to a file (the "top" portion is ignored). If you put the report on the drawing, the report justification is top right.

### Available Fields



<b>TAGNAME</b>	Tag ID value (attributes "TAG", "TAG1", "TAGSTRIP", "P_TAG1")
<b>INST</b>	Installation attribute value
<b>LOC</b>	Location attribute value
<b>COMMENT</b>	Comment or explanation of issue
<b>PNL</b>	Value of the problem area on the footprint component; shows the value on the panel layout (i.e. If the Comment is "Mismatch LOC", the LOC attribute is different between the Panel Layout and Schematic components).
<b>SCHEM</b>	Value of the problem area on the component; shows the value on the schematic drawing (i.e. If the Comment is "Mismatch LOC", the LOC attribute is different between the Panel Layout and Schematic components).
<b>HDL</b>	Entity handle number

SH	Sheet - the %S value
SHDWGNAM	Drawing name - the %D value
FULLFILENAME	AutoCAD drawing file name (.dwg) with complete path
FILENAME	AutoCAD drawing file name (.dwg)

## Panel wire connection data fields to report

Changes what data fields are reported and the order in which they appear.

 **Ribbon:** Reports tab > Panel panel > Reports. 

 **Toolbar:** Panel Layout 

 **Menu:** Projects > Reports > Panel Reports

 **Command entry:** AEPANELREPORT

Select Wire Connection from the report list. Run the report and click Change Report Format on the Report Generator dialog box.

<b>Available Fields</b>	Lists the available fields for formatting the report (including user-defined attributes). Select a field from the list to transfer it into the Fields to Report list.
<b>Fields to Report</b>	Lists the fields to display in the report.
<b>Remove/Remove All</b>	Removes the selected field or all fields from the Fields to Report list.
<b>Move Up</b>	Moves the selected field up one spot in the Fields to Report list.
<b>Move Down</b>	Moves the selected field down one spot in the Fields to Report list.
<b>Change field name/justification</b>	Specifies the vertical and horizontal justification (Top Left, Middle Center, Bottom Right) of any column and the column label (default is Top Left). The vertical portion of the justification (Top, Middle, Bottom) is only used for the

Put on Drawing report feature. For example, if you select "Top Right" the report is right-justified during the display, printing and when saved to a file (the "top" portion is ignored). If you put the report on the drawing, the report justification is top right.







### Available Fields

<b>TAGNAME</b>	Tag ID value (attributes "TAG", "TAG1", "TAGSTRIP", "P_TAG1")
<b>PIN</b>	Wire connection terminal pin number
<b>WIRENO</b>	Wire number
<b>WTYPE</b>	Alternate type of symbol (for example, "PN" for pneumatic, "HY" for hydraulic)
<b>INST</b>	Installation attribute value
<b>LOC</b>	Location attribute value
<b>MOUNT</b>	Mount attribute value; panel layout optional attribute for user-defined "panel mounting" assignment
<b>GROUP</b>	GROUPWITH attribute value; panel layout optional attribute for user-defined "group with" assignment
<b>END1</b>	Component and connection information on one end of wire (must end with "1")
<b>END2</b>	Component and connection information on one end of wire (must end with "2")
<b>MFG</b>	Manufacturer or vendor name (i.e. Siemens)
<b>CAT</b>	Catalog part number assignment
<b>ASSYCODE</b>	Optional assembly code value used in catalog lookup query to get part number groups
<b>BLKNAME</b>	WDBLKNAM attribute value used for the linking of symbols to tables in the Default CAT database

ITEM	Item number assignment on Panel drawings; there is no correlation between schematic and panel item number attributes
DWGIX	"From" device's drawing DWGIX value as listed in FILETIME table of project scratch database
HDL	Entity handle number
CATEGORY	Type of component (J = plug-jack connector, P = PLC I/O, C = cable marker, FP = Panel Footprint, FPT = terminal footprint)
PDESC	Wire connection point description attribute value
SFX	Values of R or L; used for terminal block symbols where we identify the wire annotation attributes with an R or L for Right or Left of the symbol
SH	Sheet - the %S value
SHDWGNAM	Drawing name - the %D value
X	X-coordinate
Y	Y-coordinate
Z	Z-coordinate
CBL	Cable tag
TEXT	Wire annotation text

## Bill of material data fields to report

Changes what data fields are reported and the order in which they appear.

-  **Ribbon:** Reports tab ► Schematic panel ► Reports.
 
-  **Toolbar:** Main Electrical 2
 
-  **Menu:** Projects ► Reports ► Schematic Reports
-  **Command entry:** AESCHEMATICREPORT

Select Bill of Material from the report list. Run the report and click Change Report Format on the Report Generator dialog box.

<b>Available Fields</b>	Lists the available fields for formatting the report (including user-defined attributes). Select a field from the list to transfer it into the Fields to Report list.
<b>Fields to Report</b>	Lists the fields to display in the report.
<b>Remove/Remove All</b>	Removes the selected field or all fields from the Fields to Report list.
<b>Move Up</b>	Moves the selected field up one spot in the Fields to Report list.
<b>Move Down</b>	Moves the selected field down one spot in the Fields to Report list.
<b>Change field name/justification</b>	Specifies the vertical and horizontal justification (Top Left, Middle Center, Bottom Right) of any column and the column label (default is Top Left). The vertical portion of the justification (Top, Middle, Bottom) is only used for the Put on Drawing report feature. For example, if you select "Top Right" the report is right-justified during the display, printing and when saved to a file (the "top" portion is ignored). If you put the report on the drawing, the report justification is top right.
<b>Lines for description</b>	The Description field can be multilined. If you include the Description field in your report, choose which lines make up this field. Switch on and off the specific fields to define the Description.

### **Available Fields**

The fields that are available depend on the display options you selected when running the report. Some fields are not applicable in certain display options.

<b>ITEM</b>	Item number assignment; purchase list items for Purchase Tallied Format reports.
-------------	--

N/A	Not applicable or not used; if a report does not use a particular field, N/A is used to line up the raw data and make them consistent between all formats for the BOM
QTY	Quantity
SUB	Subassembly quantity
CATALOG	Catalog part number assignment
MFG	Manufacturer or vendor name (i.e. Siemens)
ASSYCODE	Optional assembly code value used in catalog lookup query to get part number groups
DESCRIPTION	Multiline description column
DESC	General component description line of text
QUERY2	2nd query field (middle pulldown on Catalog Lookup dialog box)
QUERY3	3rd query field (right-hand pull-down on Catalog Lookup dialog box)
MISC1-2	Catalog lookup data fields
USER1-3	User fields in catalog lookup database
TABNAM	Catalog database table name
TAGS or TAG	Component tag names
INST	Installation attribute value
LOC	Location attribute value
HDL	Entity handle number
DWGIX	DWGIX value as listed in FILETIME table of project scratch database

### **Cable summary data fields to report**

Changes what data fields are reported and the order in which they appear.



 **Ribbon:** Reports tab ► Schematic panel ► Reports.

 **Toolbar:** Main Electrical 2

**Menu:** Projects ► Reports ► Schematic Reports

**Command entry:** AESCHEMATICREPORT

Select Cable Summary from the report list. Run the report and click Change Report Format on the Report Generator dialog box.

<b>Available Fields</b>	Lists the available fields for formatting the report (including user-defined attributes). Select a field from the list to transfer it into the Fields to Report list.
<b>Fields to Report</b>	Lists the fields to display in the report.
<b>Remove/Remove All</b>	Removes the selected field or all fields from the Fields to Report list.
<b>Move Up</b>	Moves the selected field up one spot in the Fields to Report list.
<b>Move Down</b>	Moves the selected field down one spot in the Fields to Report list.
<b>Change field name/justification</b>	Specifies the vertical and horizontal justification (Top Left, Middle Center, Bottom Right) of any column and the column label (default is Top Left). The vertical portion of the justification (Top, Middle, Bottom) is only used for the Put on Drawing report feature. For example, if you select "Top Right" the report is right-justified during the display, printing and when saved to a file (the "top" portion is ignored). If you put the report on the drawing, the report justification is top right.

### Available Fields

<b>CBL</b>	Cable tag
<b>DESC1-3</b>	Description attribute values 1-3

<b>MFG</b>	Manufacturer or vendor name (i.e. Siemens)
<b>CAT</b>	Catalog part number assignment
<b>ASSYCODE</b>	Optional assembly code value used in catalog lookup query to get part number groups
<b>CBLDESCCAT</b>	Cable BOM single line description field (pulled from the catalog lookup file for the cable's catalog part number query)
<b>CBLQ1CAT</b>	Cable BOM query1 value (pulled from the catalog lookup file for the cable's catalog part number query)
<b>CBLQ2CAT</b>	Cable BOM query2 value (pulled from the catalog lookup file for the cable's catalog part number query)
<b>CBLMISC1CAT- CBLMISC2CAT</b>	Cable BOM miscellaneous fields (pulled from the catalog lookup file for the cable's catalog part number query)
<b>CBLUSER1CAT- CBLUSER3CAT</b>	Cable BOM user fields (pulled from the catalog lookup file for the cable's catalog part number query)
<b>REF</b>	Line reference or X-Y grid reference or X-Zone reference
<b>LOC</b>	Location attribute value
<b>SH</b>	Sheet - the %S value
<b>SHDWGNAM</b>	Drawing name - the %D value
<b>HDL</b>	Entity handle number
<b>INST</b>	Installation attribute value
<b>DWGIX</b>	"From" device's drawing DWGIX value as listed in FILETIME table of project scratch database

### **Cable from/to data fields to report**

Changes what data fields are reported and the order in which they appear.

 **Ribbon:** Reports tab ► Schematic panel ► Reports.

 **Toolbar:** Main Electrical 2

**Menu:** Projects ► Reports ► Schematic Reports

**Command entry:** AESCHEMATICREPORT

Select Cable From/To from the report list. Run the report. Select the location codes for the report and click Change Report Format on the Report Generator dialog box.

<b>Available Fields</b>	Lists the available fields for formatting the report (including user-defined attributes). Select a field from the list to transfer it into the Fields to Report list.
<b>Fields to Report</b>	Lists the fields to display in the report.
<b>Remove/Remove All</b>	Removes the selected field or all fields from the Fields to Report list.
<b>Move Up</b>	Moves the selected field up one spot in the Fields to Report list.
<b>Move Down</b>	Moves the selected field down one spot in the Fields to Report list.
<b>Change field name/justification</b>	Specifies the vertical and horizontal justification (Top Left, Middle Center, Bottom Right) of any column and the column label (default is Top Left). The vertical portion of the justification (Top, Middle, Bottom) is only used for the Put on Drawing report feature. For example, if you select "Top Right" the report is right-justified during the display, printing and when saved to a file (the "top" portion is ignored). If you put the report on the drawing, the report justification is top right.

### Available Fields

<b>WIRENO</b>	Wire number
<b>LOC1</b>	"From" device's location code (must end with "1")

<b>CMP1</b>	"From" device's component tag ID (must end with "1")
<b>PIN1</b>	"From" device's wire connection terminal number (must end with "1")
<b>LOC2</b>	"To" device's location code (must end with "2")
<b>CMP2</b>	"To" device's component tag ID (must end with "2")
<b>PIN2</b>	"To" device's wire connection terminal number (must end with "2")
<b>WLAY1</b>	Wire layer "From" device (must end with "1")
<b>WLAY2</b>	Wire layer "To" device (must end with "2")
<b>REF1</b>	Line or grid reference location for "From" device (must end with "1")
<b>REF2</b>	Line or grid reference location for "To" device (must end with "2")
<b>SH1</b>	Sheet assignment for "From" device (must end with "1")
<b>SH2</b>	Sheet assignment for "To" device (must end with "2")
<b>CBL</b>	Cable tag
<b>CBLWC</b>	Cable wire or cable core color
<b>CBLLOC</b>	Cable location attribute value
<b>CBLMFG</b>	Cable Manufacturer attribute value
<b>CBLCAT</b>	Cable catalog part number
<b>CBLASMB</b>	Cable ASSYCODE assignment
<b>CBLDESCCAT</b>	Cable BOM single line description field (pulled from the catalog lookup file for the cable's catalog part number query)
<b>CBLQ1CAT</b>	Cable BOM query1 value (pulled from the catalog lookup file for the cable's catalog part number query)
<b>CBLQ2CAT</b>	Cable BOM query2 value (pulled from the catalog lookup file for the cable's catalog part number query)

<b>CBLMISC1CAT - CBLMISC2CAT</b>	Cable BOM miscellaneous fields (pulled from the catalog lookup file for the cable's catalog part number query)
<b>CBLUSER1CAT - CBLUSER3CAT</b>	Cable BOM user fields (pulled from the catalog lookup file for the cable's catalog part number query)
<b>DESC1CBL-DESC3CBL</b>	Cable description attribute values 1 - 3
<b>CBLP1C2</b>	Cable parent or child (parent = 1, child = 2)
<b>CMP:PIN1</b>	"From" device's component tag and component terminal pin number
<b>CMP:PIN2</b>	"To" device's component tag and component terminal pin number
<b>SEC1</b>	"From" device's drawing section assignment
<b>SUB1</b>	"From" device's drawing sub-section assignment
<b>SEC2</b>	"TO" device's drawing section assignment
<b>SUB2</b>	"TO" device's drawing sub-section assignment
<b>INST1</b>	"From" device's installation code
<b>INST2</b>	"To" device's installation code
<b>IECCMP1</b>	"From" device's IEC tag name (must end with "1")
<b>IECCMP2</b>	"To" device's IEC tag name (must end with "2")
<b>PD1</b>	"From" device's wire connection TERMDESC value (must end with "1")
<b>PD2</b>	"To" device's wire connection TERMDESC value (must end with "2")
<b>SEQ1</b>	"From" device's wire connection sequence value (must end with "1")
<b>SEQ2</b>	"To" device's wire connection sequence value (must end with "2")
<b>PNLWDLEV1</b>	"From" device's panel equivalent level (WDLEV) value (must end with "1")

<b>PNLWDLEV2</b>	"To" device's panel equivalent level (WDLEV) value (must end with "2")
<b>CMPHDL1</b>	"From" device's entity handle value (must end with "1")
<b>CMPHDL2</b>	"To" device's entity handle value (must end with "2")
<b>DWGIX1</b>	"From" device's drawing DWGIX value as listed in FILETIME table of project scratch database (must end with "1")
<b>DWGIX2</b>	"To" device's drawing DWGIX value as listed in FILETIME table of project scratch database (must end with "2")
<b>DWGNAM1</b>	"From" device's drawing properties %D value (must end with "1")
<b>DWGNAM2</b>	"To" device's drawing properties %D value (must end with "2")
<b>CBLHDL</b>	Cable entity's handle value
<b>CBLINST</b>	Cable entity's handle value
<b>CBLDWGIX</b>	Cable's drawing DWGIX value as listed in FILETIME table of project scratch database
<b>WIREHDL1</b>	"From" device's connected wire line entity handle value (must end with "1")
<b>WIREHDL2</b>	"To" device's connected wire line entity handle value (must end with "2")
<b>XDIR1</b>	"From" device's wire connection point direction - i.e. 4 = connects from left (must end with "1")
<b>XDIR2</b>	"To" device's wire connection point direction - i.e. 2 = connects from above (must end with "2")
<b>PNLX1</b>	"From" wire connection's physical X-coordinate value (must end with "1")
<b>PNLY1</b>	"From" wire connection's physical Y-coordinate value (must end with "1")

PNLZ1	"From" wire connection's physical Z-coordinate value (must end with "1")
PNLXDIR1	Panel wire "From" connection point's direction - i.e. 4 = connects from left, 1 = right, 2 = above, 8 = below (must end with "1")
PNLX2	"To" wire connection's physical X-coordinate value (must end with "2")
PNLY2	"To" wire connection's physical Y-coordinate value (must end with "2")
PNLZ2	"To" wire connection's physical Z-coordinate value (must end with "2")
PNLXDIR2	Panel wire "To" connection point's direction - i.e. 4 = connects from left, 1 = right, 2 = above, 8 = below (must end with "2")
CLEN	Panel layout calculated wire length
USER1_1 to USER20_1	"From" device's optional user field
USER1_2 to USER20_2	"To" device's optional user field

## Cable label data fields to report

Changes what data fields are reported and the order in which they appear.

 **Ribbon:** Reports tab ► Schematic panel ► Reports.

 **Toolbar:** Main Electrical 2

**Menu:** Projects ► Reports ► Schematic Reports

**Command entry:** AESCHEMATICREPORT

Select Wire Label from the report list. Run the report and click Cable Label on the Report Generator dialog box.

### Available Fields

Lists the available fields for formatting the report (including user-defined attributes). Select a field from the list to transfer it into the Fields to Report list.



<b>Fields to Report</b>	Lists the fields to display in the report.
<b>Remove/Remove All</b>	Removes the selected field or all fields from the Fields to Report list.
<b>Move Up</b>	Moves the selected field up one spot in the Fields to Report list.
<b>Move Down</b>	Moves the selected field down one spot in the Fields to Report list.
<b>Separator</b>	<p>Specifies the special character to separate the selected fields. Enter a special character to separate the selected fields inside the list box. Do this by selecting a field from the Fields to Report list, define the separator, select another field, define a separator, and so on. You can also select the separator from a list.</p> <p>The "\n" symbol stands for the new line. When you use this as separator, the field displays in the new (next) line.</p>

### Available Fields

<b>CBL</b>	Cable name
<b>LOC1</b>	Location of "From" components
<b>FROM_CMPS</b>	Components that are in the "From" end of cable
<b>LOC2</b>	Location of "To" components
<b>TO_CMPS</b>	Components that are in the "To" end of cable
<b>DESC1CBL-DESC3CBL</b>	Cable's description lines 1-3

### PLC component connection data fields to report

Changes what data fields are reported and the order in which they appear.

 **Ribbon:** Reports tab ► Schematic panel ► Reports. 





**Toolbar:** Main Electrical 2

**Menu:** Projects > Reports > Schematic Reports

**Command entry:** AESCHEMATICREPORT

Select PLC I/O Component Connection from the report list. Run the report and click Change Report Format on the Report Generator dialog box.

<b>Available Fields</b>	Lists the available fields for formatting the report (including user-defined attributes). Select a field from the list to transfer it into the Fields to Report list.
<b>Fields to Report</b>	Lists the fields to display in the report.
<b>Remove/Remove All</b>	Removes the selected field or all fields from the Fields to Report list.
<b>Move Up</b>	Moves the selected field up one spot in the Fields to Report list.
<b>Move Down</b>	Moves the selected field down one spot in the Fields to Report list.
<b>Change field name/justification</b>	Specifies the vertical and horizontal justification (Top Left, Middle Center, Bottom Right) of any column and the column label (default is Top Left). The vertical portion of the justification (Top, Middle, Bottom) is only used for the Put on Drawing report feature. For example, if you select "Top Right" the report is right-justified during the display, printing and when saved to a file (the "top" portion is ignored). If you put the report on the drawing, the report justification is top right.

#### **Available Fields**

<b>PLCNUM</b>	Wire number associated with PLC I/O point
<b>PLCTAG</b>	PLC tag ID value (attribute "TAG" or "TAG1")
<b>PLCADDR</b>	PLC I/O point address (attribute "TAGAx" where xx is "01" - "xx")

<b>PLCDESCA-PLCDESCE</b>	PLC I/O description text lines 1 - 5
<b>PLCTERM</b>	PLC I/O terminal text value, attribute TERMxx
<b>PLCTERMDESC</b>	PLC I/O terminal description text value, attribute TERM-DESCxx
<b>PLCINST</b>	PLC I/O module's Installation attribute value
<b>PLCLOC</b>	PLC I/O module's Location attribute value
<b>WLAY</b>	Wire layer name
<b>PLCMFG</b>	PLC I/O module's Manufacturer attribute value
<b>PLCCAT</b>	PLC I/O module's Catalog part number
<b>PLCASSYCODE</b>	PLC I/O module's ASSYCODE attribute value
<b>PLCTERMCODE</b>	PLC I/O terminal attribute suffix value (the "xx" part of TERMxx)
<b>PLCDWGIX</b>	PLC Drawing DWGIX value as listed in FILETIME table of project
<b>PLCHDL</b>	PLC I/O module's AutoCAD handle value
<b>PLCLINE1</b>	PLC I/O module's LINE1 attribute value (miscellaneous text such as "Rack" or "Slot")
<b>PLCLINE2</b>	PLC I/O module's LINE2 attribute value (miscellaneous text such as "Rack" or "Slot")
<b>CMPTAG</b>	Connected component tag ID (attributes "TAG1", "TAG2", "TAGSTRIP")
<b>CMPEDESC1-3</b>	Connected component description attribute values 1 - 3
<b>CMPIINST</b>	Connected component Installation attribute value
<b>CMPLLOC</b>	Connected component Location attribute value

<b>CMPTERM</b>	Connected component TERMxx attribute value (the side that connects to the PLC I/O point)
<b>CMPTERMDESC</b>	Connected component TERMDDESCxx attribute value (the side that connects to the PLC I/O point)
<b>CMPMFG</b>	Connected component Manufacturer attribute value
<b>CMPCAT</b>	Connected component catalog part number
<b>COMPASSYCODE</b>	Connected component ASSYCODE attribute value
<b>CMPDWGIX</b>	Connected component's Drawing DWGIX value as listed in FILETIME table of project scratch database
<b>CMPHDL</b>	Connected component's AutoCAD handle value
<b>CMPLKNAM</b>	Connected component's AutoCAD block name
<b>TERMTAG</b>	Connected terminal's TAGSTRIP attribute value
<b>TERMINST</b>	Connected terminal's Installation attribute value
<b>TERMLOC</b>	Connected terminal's Location attribute value
<b>TERMTERM</b>	Connected terminal's TERM or TERM01 attribute value
<b>TERMTERMDESC</b>	Connected terminal's TERMDDESC01 attribute value
<b>TERMMFG</b>	Connected terminal's Manufacturer attribute value
<b>TERMCAT</b>	Connected terminal's catalog part number
<b>TERMASSYCODE</b>	Connected terminal's ASSYCODE attribute value
<b>TERMDWGIX</b>	Connected terminal's Drawing DWGIX value as listed in FILETIME table of project scratch database
<b>TERMHDL</b>	Connected terminal's AutoCAD handle value
<b>TERMBLKNAM</b>	Connected terminal's AutoCAD block name
<b>CBL</b>	Cable tag

CBLWC	Cable wire or cable core color
CBLHDL	Cable entity's handle value

## Component wire list data fields to report

Changes what data fields are reported and the order in which they appear.

 **Ribbon:** Reports tab ► Schematic panel ► Reports.

 **Toolbar:** Main Electrical 2

 **Menu:** Projects ► Reports ► Schematic Reports

 **Command entry:** AESCHEMATICREPORT

Select Component Wire List from the report list. Run the report and click Change Report Format on the Report Generator dialog box.

<b>Available Fields</b>	Lists the available fields for formatting the report (including user-defined attributes). Select a field from the list to transfer it into the Fields to Report list.
<b>Fields to Report</b>	Lists the fields to display in the report.
<b>Remove/Remove All</b>	Removes the selected field or all fields from the Fields to Report list.
<b>Move Up</b>	Moves the selected field up one spot in the Fields to Report list.
<b>Move Down</b>	Moves the selected field down one spot in the Fields to Report list.
<b>Change field name/justification</b>	Specifies the vertical and horizontal justification (Top Left, Middle Center, Bottom Right) of any column and the column label (default is Top Left). The vertical portion of the justification (Top, Middle, Bottom) is only used for the Put on Drawing report feature. For example, if you select "Top Right" the report is right-justified during the display, printing and when saved to a file (the "top" portion is ig-

nored). If you put the report on the drawing, the report justification is top right.



### Available Fields

<b>WIRENO</b>	Wire number
<b>PIN</b>	Wire connection terminal pin number
<b>TAGNAME</b>	Tag ID value (attributes "TAG", "TAG1", "TAGSTRIP", "P_TAG1")
<b>LOC</b>	Location attribute value
<b>WLAY</b>	Wire layer name
<b>P1C2</b>	parent = 1, child = 2
<b>REF</b>	Line reference or X-Y grid reference or X-Zone reference
<b>SH</b>	Sheet - the %S value
<b>SHDWGNAM</b>	Drawing name - the %D value
<b>BLKNAME</b>	Block name
<b>HDL</b>	Entity handle number
<b>XTERM</b>	Wire connection X?TERMxx suffix. (for example, for attribute X4TERM05 the value would be "05")
<b>CBL</b>	Cable
<b>CBLWC</b>	Cable wire or cable core color
<b>NONC</b>	Contact attribute value; Normally Open (NO) or Normally Closed (NC) contact state
<b>SEC</b>	Drawing section assignment
<b>SUBSEC</b>	Drawing sub-section assignment
<b>TERMDESC</b>	Component wire connection TERMDESCxx value

<b>INST</b>	Installation attribute value
<b>DESC1-3</b>	Description attribute values 1-3
<b>MFG</b>	Manufacturer or vendor name (i.e. Siemens)
<b>CATALOG</b>	Catalog part number assignment
<b>ASSYCODE</b>	Optional assembly code value used in catalog lookup query to get part number groups
<b>RATING1-12</b>	Rating 1 - 12 attribute values
<b>XTERMHDL</b>	Wire connection X?TERMxx attribute's entity handle name
<b>XDIR</b>	Wire connection X?TERMxx attribute's direction code and suffix
<b>DWGIX</b>	"From" device's drawing DWGIX value as listed in FILETIME table of project scratch database

## Connector details data fields to report

Changes what data fields are reported and the order in which they appear.

 **Ribbon:** Reports tab ► Schematic panel ► Reports. 

 **Toolbar:** Main Electrical 2 

 **Menu:** Projects ► Reports ► Schematic Reports

 **Command entry:** AESCHEMATICREPORT

Select Connector Details from the report list. Run the report and click Change Report Format on the Report Generator dialog box.

**Available Fields** Lists the available fields for formatting the report (including user-defined attributes). Select a field from the list to transfer it into the Fields to Report list.

**Fields to Report** Lists the fields to display in the report.

<b>Remove/Remove All</b>	Removes the selected field or all fields from the Fields to Report list.
<b>Move Up</b>	Moves the selected field up one spot in the Fields to Report list.
<b>Move Down</b>	Moves the selected field down one spot in the Fields to Report list.
<b>Change field name/justification</b>	Specifies the vertical and horizontal justification (Top Left, Middle Center, Bottom Right) of any column and the column label (default is Top Left). The vertical portion of the justification (Top, Middle, Bottom) is only used for the Put on Drawing report feature. For example, if you select "Top Right" the report is right-justified during the display, printing and when saved to a file (the "top" portion is ignored). If you put the report on the drawing, the report justification is top right.

### Available Fields

<b>CONNECTOR</b>	Tag ID of plug/jack connector
<b>PIN</b>	Wire connection terminal pin number
<b>TYPE</b>	Child contact type; P = Plug and J = Jack
<b>WIRENO</b>	Wire number
<b>DESC1-3</b>	Description attribute values 1-3
<b>MFG</b>	Manufacturer or vendor name (i.e. Siemens)
<b>CATALOG</b>	Catalog part number assignment
<b>ASSYCODE</b>	Optional assembly code value used in catalog lookup query to get part number groups
<b>REF</b>	Line reference or X-Y grid reference or X-Zone reference
<b>INST</b>	Installation attribute value
<b>LOC</b>	Location attribute value

<b>SH</b>	Sheet - the %S value
<b>SHDWGNAM</b>	Drawing name - the %D value
<b>HDL</b>	Entity handle number; used internally for programming or customization
<b>RATING1-12</b>	Rating 1 - 12 attribute values
<b>DWGIX</b>	"From" device's drawing DWGIX value as listed in FILETIME table of project scratch database; used internally for programming or customization

## Connector plug data fields to report

Changes what data fields are reported and the order in which they appear.

 **Ribbon:** Reports tab ► Schematic panel ► Reports.



 **Toolbar:** Main Electrical 2



 **Menu:** Projects ► Reports ► Schematic Reports

 **Command entry:** AESCHEMATICREPORT

Select Connector Plug from the report list. Run the report and click Change Report Format on the Report Generator dialog box.

<b>Available Fields</b>	Lists the available fields for formatting the report (including user-defined attributes). Select a field from the list to transfer it into the Fields to Report list.
<b>Fields to Report</b>	Lists the fields to display in the report.
<b>Remove/Remove All</b>	Removes the selected field or all fields from the Fields to Report list.
<b>Move Up</b>	Moves the selected field up one spot in the Fields to Report list.
<b>Move Down</b>	Moves the selected field down one spot in the Fields to Report list.



**Change field name/justification** Specifies the vertical and horizontal justification (Top Left, Middle Center, Bottom Right) of any column and the column label (default is Top Left). The vertical portion of the justification (Top, Middle, Bottom) is only used for the Put on Drawing report feature. For example, if you select "Top Right" the report is right-justified during the display, printing and when saved to a file (the "top" portion is ignored). If you put the report on the drawing, the report justification is top right.



### Available Fields

<b>WIRENO</b>	Wire number
<b>PIN</b>	Wire connection terminal pin number
<b>TAGNAME</b>	Tag ID value (attributes "TAG", "TAG1", "TAGSTRIP", "P_TAG1")
<b>LOC</b>	Location attribute value
<b>WLAY</b>	Wire layer name
<b>P1C2</b>	parent = 1, child = 2
<b>REF</b>	Line reference or X-Y grid reference or X-Zone reference
<b>SH</b>	Sheet - the %S value
<b>SHDWGNAM</b>	Drawing name - the %D value
<b>BLKNAME</b>	Block name
<b>HDL</b>	Entity handle number
<b>XDIR</b>	Wire connection X?TERMxx attribute's direction code and suffix
<b>CBL</b>	Cable
<b>CBLWC</b>	Cable wire or cable core color
<b>SEC</b>	Drawing section assignment
<b>SUBSEC</b>	Drawing sub-section assignment

<b>TERMDESC</b>	Component wire connection TERMDESCxx value
<b>INST</b>	Installation attribute value
<b>DESC1-3</b>	Description attribute values 1-3
<b>MFG</b>	Manufacturer or vendor name (for example, Siemens)
<b>CATALOG</b>	Catalog part number assignment
<b>ASSYCODE</b>	Optional assembly code value used in catalog lookup query to get part number groups
<b>RATING1-12</b>	Rating 1 - 12 attribute values
<b>XTERMHDL</b>	Wire connection X?TERMxx attribute's entity handle name
<b>DWGIX</b>	"From" device's drawing DWGIX value as listed in FILETIME table of project scratch database

## Connector summary data fields to report

Changes what data fields are reported and the order in which they appear.

 **Ribbon:** Reports tab ► Schematic panel ► Reports. 

 **Toolbar:** Main Electrical 2 

 **Menu:** Projects ► Reports ► Schematic Reports

 **Command entry:** AESCHEMATICREPORT

Select Connector Summary from the report list. Run the report and click Change Report Format on the Report Generator dialog box.

**Available Fields** Lists the available fields for formatting the report (including user-defined attributes). Select a field from the list to transfer it into the Fields to Report list.

**Fields to Report** Lists the fields to display in the report.

<b>Remove/Remove All</b>	Removes the selected field or all fields from the Fields to Report list.
<b>Move Up</b>	Moves the selected field up one spot in the Fields to Report list.
<b>Move Down</b>	Moves the selected field down one spot in the Fields to Report list.
<b>Change field name/justification</b>	Specifies the vertical and horizontal justification (Top Left, Middle Center, Bottom Right) of any column and the column label (default is Top Left). The vertical portion of the justification (Top, Middle, Bottom) is only used for the Put on Drawing report feature. For example, if you select "Top Right" the report is right-justified during the display, printing and when saved to a file (the "top" portion is ignored). If you put the report on the drawing, the report justification is top right.

### Available Fields

<b>CONNECTOR</b>	Tag ID of plug/jack connector
<b>MAX</b>	Maximum number of pins
<b>USED</b>	Count of used or in-use pins
<b>PINSUSED</b>	List of wire connection pin number in use
<b>REPEATS</b>	Pin numbers repeated
<b>INST</b>	Installation attribute value
<b>LOC</b>	Location attribute value
<b>MFG</b>	Manufacturer or vendor name (i.e. Siemens)
<b>CATALOG</b>	Catalog part number assignment
<b>ASSYCODE</b>	Optional assembly code value used in catalog lookup query to get part number groups
<b>HDL</b>	Entity handle number

DWGIX

"From" device's drawing DWGIX value as listed in FILETIME table of project scratch database

## Component data fields to report

Changes what data fields are reported and the order in which they appear.

 **Ribbon:** Reports tab ► Schematic panel ► Reports.

 **Toolbar:** Main Electrical 2  
**Menu:** Projects ► Reports ► Schematic Reports

 **Command entry:** AESCHEMATICREPORT  
Select Component from the report list. Run the report and click Change Report Format on the Report Generator dialog box.

<b>Available Fields</b>	Lists the available fields for formatting the report (including user-defined attributes). Select a field from the list to transfer it into the Fields to Report list.
<b>Fields to Report</b>	Lists the fields to display in the report.
<b>Remove/Remove All</b>	Removes the selected field or all fields from the Fields to Report list.
<b>Move Up</b>	Moves the selected field up one spot in the Fields to Report list.
<b>Move Down</b>	Moves the selected field down one spot in the Fields to Report list.
<b>Change field name/justification</b>	Specifies the vertical and horizontal justification (Top Left, Middle Center, Bottom Right) of any column and the column label (default is Top Left). The vertical portion of the justification (Top, Middle, Bottom) is only used for the Put on Drawing report feature. For example, if you select "Top Right" the report is right-justified during the display, printing and when saved to a file (the "top" portion is ignored). If you

put the report on the drawing, the report justification is top right.



### Available Fields

<b>ITEM</b>	Item number assignment
<b>TAGNAME</b>	Tag ID value (attributes "TAG", "TAG1", "TAGSTRIP", "P_TAG1")
<b>CNT</b>	Count on panel component
<b>UNITS</b>	Units of measurement (i.e. AMPS, VOLTS, mA) on panel component
<b>SUBQTY</b>	Subassembly quantity
<b>MFG</b>	Manufacturer or vendor name (for example, Siemens)
<b>CAT</b>	Catalog part number assignment
<b>DESC1-3</b>	Description attribute values 1-3
<b>REF</b>	Line reference or X-Y grid reference or X-Zone reference
<b>INST</b>	Installation attribute value
<b>LOC</b>	Location attribute value
<b>RATING1-12</b>	Rating 1 - 12 attribute values
<b>CATDESC</b>	Catalog one-line description text
<b>QUERY1</b>	QUERY1 field pulled from catalog lookup
<b>QUERY2</b>	2nd query field (middle pulldown on Catalog Lookup dialog box)
<b>MISC1-2</b>	Catalog lookup data fields
<b>USER1-3</b>	User fields in catalog lookup database
<b>P1C2</b>	parent = 1, child = 2
<b>WDBLKNAM</b>	Name of the component's catalog lookup table

<b>BLOCK</b>	Block name
<b>HDL</b>	Entity handle number
<b>CATEGORY</b>	Type of component (J = plug-jack connector, P = PLC I/O, C = cable marker)
<b>ASSYCODE</b>	Optional assembly code value used in catalog lookup query to get part number groups
<b>SH</b>	Sheet - the %S value
<b>SHDWGNAM</b>	Drawing name - the %D value
<b>SEC</b>	Drawing SEC assignment
<b>SUBSEC</b>	Drawing SUBSEC assignment
<b>FAMILY</b>	Component family
<b>WDTAGALT</b>	Tag-ID of device on alternate drawing type
<b>WDTYPE</b>	Alternate type of symbol (for example, "PN" for pneumatic, "HY" for hydraulic)
<b>FILENAME</b>	AutoCAD drawing .dwg file name (with full path)

## Missing bill of material data fields to report

Changes what data fields are reported and the order in which they appear.

 **Ribbon:** Reports tab ► Schematic panel ► Reports. 

 **Toolbar:** Main Electrical 2 

 **Menu:** Projects ► Reports ► Schematic Reports

 **Command entry:** AESCHEMATICREPORT

Select Missing Bill of Material from the report list. Run the report and click Change Report Format on the Report Generator dialog box.

<b>Available Fields</b>	Lists the available fields for formatting the report (including user-defined attributes). Select a field from the list to transfer it into the Fields to Report list.
<b>Fields to Report</b>	Lists the fields to display in the report.
<b>Remove/Remove All</b>	Removes the selected field or all fields from the Fields to Report list.
<b>Move Up</b>	Moves the selected field up one spot in the Fields to Report list.
<b>Move Down</b>	Moves the selected field down one spot in the Fields to Report list.
<b>Change field name/justification</b>	Specifies the vertical and horizontal justification (Top Left, Middle Center, Bottom Right) of any column and the column label (default is Top Left). The vertical portion of the justification (Top, Middle, Bottom) is only used for the Put on Drawing report feature. For example, if you select "Top Right" the report is right-justified during the display, printing and when saved to a file (the "top" portion is ignored). If you put the report on the drawing, the report justification is top-right.

### Available Fields

<b>TAGNAME</b>	Tag ID value (attributes "TAG", "TAG1", "TAGSTRIP", "P_TAG1")
<b>INST</b>	Installation attribute value
<b>LOC</b>	Location attribute value
<b>DESC1-3</b>	Description attribute values 1-3
<b>REF</b>	Line reference or X-Y grid reference or X-Zone reference
<b>TABNAM</b>	Catalog database table name
<b>HDL</b>	Entity handle number

<b>CATEGORY</b>	Type of component (J = plug-jack connector, P = PLC I/O, C = cable marker)
<b>SH</b>	Sheet - the %S value
<b>SHDWGNAM</b>	Drawing name - the %D value
<b>FILENAME</b>	AutoCAD drawing .dwg file name (with full path)

## Wire from/to data fields to report

Changes what data fields are reported and the order in which they appear.

 **Ribbon:** Reports tab ► Schematic panel ► Reports.



 **Toolbar:** Main Electrical 2



 **Menu:** Projects ► Reports ► Schematic Reports

 **Command entry:** AESCHEMATICREPORT

Select Wire From/To from the report list. Run the report. Select the location codes for the report and click Change Report Format on the Report Generator dialog box.

<b>Available Fields</b>	Lists the available fields for formatting the report (including user-defined attributes). Select a field from the list to transfer it into the Fields to Report list.
<b>Fields to Report</b>	Lists the fields to display in the report.
<b>Remove/Remove All</b>	Removes the selected field or all fields from the Fields to Report list.
<b>Move Up</b>	Moves the selected field up one spot in the Fields to Report list.
<b>Move Down</b>	Moves the selected field down one spot in the Fields to Report list.
<b>Change field name/justification</b>	Specifies the vertical and horizontal justification (Top Left, Middle Center, Bottom Right) of any column and the



column label (default is Top Left). The vertical portion of the justification (Top, Middle, Bottom) is only used for the Put on Drawing report feature. For example, if you select "Top Right" the report is right-justified during the display, printing and when saved to a file (the "top" portion is ignored). If you put the report on the drawing, the report justification is top right.

### Available Fields

<b>WIRENO</b>	Wire number
<b>LOC1</b>	"From" device's location code (must end with "1")
<b>CMP1</b>	"From" device's component tag ID (must end with "1")
<b>PIN1</b>	"From" device's wire connection terminal number (must end with "1")
<b>LOC2</b>	"To" device's location code (must end with "2")
<b>CMP2</b>	"To" device's component tag ID (must end with "2")
<b>PIN2</b>	"To" device's wire connection terminal number (must end with "2")
<b>WLAY1</b>	Wire layer "From" device (must end with "1")
<b>WLAY2</b>	Wire layer "To" device (must end with "2")
<b>REF1</b>	Line or grid reference location for "From" device (must end with "1")
<b>REF2</b>	Line or grid reference location for "To" device (must end with "2")
<b>SH1</b>	Sheet assignment for "From" device (must end with "1")
<b>SH2</b>	Sheet assignment for "To" device (must end with "2")
<b>CBL</b>	Cable tag
<b>CBLWC</b>	Cable wire or cable core color
<b>CBLLOC</b>	Cable location attribute value



<b>CBLMFG</b>	Cable manufacturer attribute value
<b>CBLCAT</b>	Cable catalog part number
<b>CBLASMB</b>	Cable ASSYCODE assignment
<b>DESC1CBL-DESC3CBL</b>	Cable description attribute values 1 - 3
<b>CBLP1C2</b>	Cable parent or child (parent = 1, child = 2)
<b>CMP:PIN1</b>	"From" device's component tag and component terminal pin number
<b>CMP:PIN2</b>	"To" device's component tag and component terminal pin number
<b>SEC1</b>	"From" device's drawing section assignment (must end with "1")
<b>SUB1</b>	"From" device's drawing sub-section assignment (must end with "1")
<b>SEC2</b>	"To" device's drawing section assignment (must end with "2")
<b>SUB2</b>	"To" device's drawing sub-section assignment (must end with "2")
<b>INST1</b>	"From" device's installation code (must end with "1")
<b>INST2</b>	"To" device's installation code (must end with "2")
<b>IECCMP1</b>	"From" device's IEC tag name (must end with "1")
<b>IECCMP2</b>	"To" device's IEC tag name (must end with "2")
<b>PD1</b>	"From" device's wire connection TERMDESC value (must end with "1")
<b>PD2</b>	"To" device's wire connection TERMDESC value (must end with "2")
<b>SEQ1</b>	"From" device's wire connection sequence value (must end with "1")
<b>SEQ2</b>	"To" device's wire connection sequence value (must end with "2")
<b>PNLWDLEV1</b>	"From" device's panel equivalent panel (WDLEV) value (must end with "1")

<b>PNLWDLEV2</b>	"To" device's panel equivalent panel (WDLEV) value (must end with "2")
<b>CMPHDL1</b>	"From" device's entity handle value (must end with "1")
<b>CMPHDL2</b>	"To" device's entity handle value (must end with "2")
<b>DWGIX1</b>	"From" device's drawing DWGIX value as listed in FILETIME table of project scratch database (must end with "1")
<b>DWGIX2</b>	"To" device's drawing DWGIX value as listed in FILETIME table of project scratch database (must end with "2")
<b>DWGNAM1</b>	"From" device's drawing %D value (must end with "1")
<b>DWGNAM2</b>	"To" device's drawing %D value (must end with "2")
<b>CBLHDL</b>	Cable entity's handle value
<b>CBLINST</b>	Cable entity's installation attribute value
<b>CBLDWGIX</b>	Cable's drawing DWGIX value as listed in FILETIME table of project scratch database
<b>WIREHDL1</b>	"From" device's connected wire line entity handle value (must end with "1")
<b>WIREHDL2</b>	"To" device's connected wire line entity handle value (must end with "2")
<b>XDIR1</b>	"From" device's wire connection point direction - i.e. 4 = connects from left (must end with "1")
<b>XDIR2</b>	"To" device's wire connection point direction - i.e. 2 = connects from above (must end with "2")
<b>PNLX1</b>	"From" wire connection's physical X-coordinate value (must end with "1")
<b>PNLY1</b>	"From" wire connection's physical Y-coordinate value (must end with "1")

PNLZ1	"From" wire connection's physical Z-coordinate value (must end with "1")
PNLXDIR1	Panel wire "From" connection point's direction - i.e. 4 = connects from left, 1 = right, 2 = above, 8 = below (must end with "1")
PNLX2	"To" wire connection's physical X-coordinate value (must end with "2")
PNLY2	"To" wire connection's physical Y-coordinate value (must end with "2")
PNLZ2	"To" wire connection's physical Z-coordinate value (must end with "2")
PNLXDIR2	Panel wire "To" connection point's direction - i.e. 4 = connects from left, 1 = right, 2 = above, 8 = below (must end with "2")
CLEN	Panel layout calculated wire length
USER1_1 to USER20_1	"From" device's optional user field
USER1_2 to USER20_2	"To" device's optional user field

## PLC I/O address and descriptions data fields to report

Changes what data fields are reported and the order in which they appear.

 **Ribbon:** Reports tab ► Schematic panel ► Reports. 

 **Toolbar:** Main Electrical 2

 **Menu:** Projects ► Reports ► Schematic Reports

 **Command entry:** AESCHEMATICREPORT

Select PLC I/O Address and Descriptions from the report list. Run the report and click Change Report Format on the Report Generator dialog box.

<b>Available Fields</b>	Lists the available fields for formatting the report (including user-defined attributes). Select a field from the list to transfer it into the Fields to Report list.
<b>Fields to Report</b>	Lists the fields to display in the report.
<b>Remove/Remove All</b>	Removes the selected field or all fields from the Fields to Report list.
<b>Move Up</b>	Moves the selected field up one spot in the Fields to Report list.
<b>Move Down</b>	Moves the selected field down one spot in the Fields to Report list.
<b>Change field name/justification</b>	Specifies the vertical and horizontal justification (Top Left, Middle Center, Bottom Right) of any column and the column label (default is Top Left). The vertical portion of the justification (Top, Middle, Bottom) is only used for the Put on Drawing report feature. For example, if you select "Top Right" the report is right-justified during the display, printing and when saved to a file (the "top" portion is ignored). If you put the report on the drawing, the report justification is top right.



#### **Available Fields**

<b>TAGNAME</b>	Tag ID value (attributes "TAG", "TAG1", "TAGSTRIP", "P_TAG1")
<b>ADDR</b>	PLC I/O point's address assignment
<b>TERM</b>	Terminal or terminal number assignment (not the STRIP-ID value)
<b>TERMDESC</b>	Component wire connection TERMDESCxx value
<b>DESCA-DESCE</b>	PLC I/O point description attribute values (lines 1-5)
<b>LREF</b>	Line reference

WIRENO	Wire number
INST	Installation attribute value
LOC	Location attribute value
MFG	Manufacturer or vendor name (for example, Siemens)
CAT	Catalog part number assignment
ASSYCODE	Optional assembly code value used in catalog lookup query to get part number groups
LINE1	PLC I/O LINE1 attribute description text
LINE2	PLC I/O LINE2 attribute description text
HDL	Entity handle number
XTERMHDL	Wire connection X?TERMxx attribute's entity handle name
TERMCODE	Wire connection X?TERMxx attribute suffix (the "xx")
SH	Sheet - the %S value
SHDWGNAM	Drawing name - the %D value
IEC_P	Drawing's IEC project default - the %P value
IEC_I	Drawing's IEC Installation default - the %I value
IEC_L	Drawing's IEC Location default - the %L value
SEC	Drawing section assignment
SUBSEC	Drawing sub-section assignment
DWGIX	"From" device's drawing DWGIX value as listed in FILETIME table of project scratch database

### **Terminal numbers data fields to report**

Changes what data fields are reported and the order in which they appear.

 **Ribbon:** Reports tab ► Schematic panel ► Reports. 

 **Toolbar:** Main Electrical 2

 **Menu:** Projects ► Reports ► Schematic Reports

 **Command entry:** AESCHEMATICREPORT

Select Terminal Numbers from the report list. Run the report and click Change Report Format on the Report Generator dialog box.

<b>Available Fields</b>	Lists the available fields for formatting the report (including user-defined attributes). Select a field from the list to transfer it into the Fields to Report list.
<b>Fields to Report</b>	Lists the fields to display in the report.
<b>Remove/Remove All</b>	Removes the selected field or all fields from the Fields to Report list.
<b>Move Up</b>	Moves the selected field up one spot in the Fields to Report list.
<b>Move Down</b>	Moves the selected field down one spot in the Fields to Report list.
<b>Change field name/justification</b>	Specifies the vertical and horizontal justification (Top Left, Middle Center, Bottom Right) of any column and the column label (default is Top Left). The vertical portion of the justification (Top, Middle, Bottom) is only used for the Put on Drawing report feature. For example, if you select "Top Right" the report is right-justified during the display, printing and when saved to a file (the "top" portion is ignored). If you put the report on the drawing, the report justification is top right.

**Available Fields**

<b>STRIP-ID</b>	Terminal strip TAGSTRIP ID name
<b>TERM</b>	Terminal or terminal number assignment (not the STRIP-ID value)

<b>WIRENO</b>	Wire number
<b>INST</b>	Installation attribute value
<b>LOC</b>	Location attribute value
<b>REF</b>	Line reference or X-Y grid reference or X-Zone reference
<b>SH</b>	Sheet - the %S value
<b>SHDWGNAM</b>	Drawing name - the %D value
<b>BLKNAME</b>	Block name
<b>MFG</b>	Manufacturer or vendor name (i.e. Siemens)
<b>CAT</b>	Catalog part number assignment
<b>ASSYCODE</b>	Optional assembly code value used in catalog lookup query to get part number groups
<b>DESC1-3</b>	Description attribute values 1-3
<b>RATNG1-12</b>	Rating 1 - 12 attribute values
<b>HDL</b>	Entity handle number
<b>DWGIX</b>	"From" device's drawing DWGIX value as listed in FILETIME table of project scratch database

## **PLC modules used so far data fields to report**

Changes what data fields are reported and the order in which they appear.

 **Ribbon:** Reports tab ► Schematic panel ► Reports.



 **Toolbar:** Main Electrical 2



 **Menu:** Projects ► Reports ► Schematic Reports

 **Command entry:** AESCHEMATICREPORT



Select PLC Modules Used So Far from the report list. Run the report and click Change Report Format on the Report Generator dialog box.

<b>Available Fields</b>	Lists the available fields for formatting the report (including user-defined attributes). Select a field from the list to transfer it into the Fields to Report list.
<b>Fields to Report</b>	Lists the fields to display in the report.
<b>Remove/Remove All</b>	Removes the selected field or all fields from the Fields to Report list.
<b>Move Up</b>	Moves the selected field up one spot in the Fields to Report list.
<b>Move Down</b>	Moves the selected field down one spot in the Fields to Report list.
<b>Change field name/justification</b>	Specifies the vertical and horizontal justification (Top Left, Middle Center, Bottom Right) of any column and the column label (default is Top Left). The vertical portion of the justification (Top, Middle, Bottom) is only used for the Put on Drawing report feature. For example, if you select "Top Right" the report is right-justified during the display, printing and when saved to a file (the "top" portion is ignored). If you put the report on the drawing, the report justification is top right.



#### **Available Fields**



<b>ADDR_BEG</b>	PLC beginning address
<b>ADDR_END</b>	PLC ending address
<b>TAG</b>	PLC tag value
<b>MFG</b>	Manufacturer or vendor name (i.e. Siemens)
<b>CAT</b>	Catalog part number assignment
<b>ASSYCODE</b>	Optional assembly code value used in catalog lookup query to get part number groups

<b>LINE1</b>	PLC I/O LINE1 attribute description text
<b>LINE2</b>	PLC I/O LINE2 attribute description text
<b>INST</b>	Installation attribute value
<b>LOC</b>	Location attribute value
<b>REF</b>	Line reference or X-Y grid reference or X-Zone reference
<b>SH</b>	Sheet - the %S value
<b>SHDWGNAM</b>	Drawing name - the %D value
<b>SEC</b>	Drawing section assignment
<b>SUBSEC</b>	Drawing sub-section assignment
<b>DESC</b>	General description line of text
<b>HDL</b>	Entity handle number
<b>DWGIX</b>	"From" device's drawing DWGIX value as listed in FILETIME table of project scratch database

## Terminal plan data fields to report

Changes what data fields are reported and the order in which they appear.

 **Ribbon:** Reports tab ► Schematic panel ► Reports. 

 **Toolbar:** Main Electrical 2 

 **Menu:** Projects ► Reports ► Schematic Reports

 **Command entry:** AESCHEMATICREPORT

Select Terminal Plan from the report list. Run the report and click Change Report Format on the Report Generator dialog box.

<b>Available Fields</b>	Lists the available fields for formatting the report (including user-defined attributes). Select a field from the list to transfer it into the Fields to Report list.
<b>Fields to Report</b>	Lists the fields to display in the report.
<b>Remove/Remove All</b>	Removes the selected field or all fields from the Fields to Report list.
<b>Move Up</b>	Moves the selected field up one spot in the Fields to Report list.
<b>Move Down</b>	Moves the selected field down one spot in the Fields to Report list.
<b>Change field name/justification</b>	Specifies the vertical and horizontal justification (Top Left, Middle Center, Bottom Right) of any column and the column label (default is Top Left). The vertical portion of the justification (Top, Middle, Bottom) is only used for the Put on Drawing report feature. For example, if you select "Top Right" the report is right-justified during the display, printing and when saved to a file (the "top" portion is ignored). If you put the report on the drawing, the report justification is top right.

#### **Available Fields**

<b>INST1</b>	"From" device's installation code
<b>LOC1</b>	"From" device's location code (must end with "1")
<b>CMP1</b>	"From" device's component tag ID (must end with "1")
<b>PIN1</b>	"From" device's wire connection terminal number (must end with "1")
<b>PD1</b>	"From" device's wire connection TERMDESC value (must end with "1")

<b>LAYCMP1</b>	Layer of wire connecting to device component 1 (must end with "1")
<b>CBL1</b>	Cable ID tied to device component 1 (must end with "1")
<b>CBLWC1</b>	Cable wire color tied to device component 1 (must end with "1")
<b>WNUM1</b>	Wire number tied to device component 1 (must end with "1")
<b>LAYTRM1</b>	Layer of wire connecting to terminal side 1 (must end with "1")
<b>STRIP-ID</b>	Terminal strip TAGSTRIP ID name
<b>TD1</b>	Terminal pin TERMDISC value for the first wire connection (must end with "1")
<b>TERM</b>	Terminal or terminal number assignment (not the STRIP-ID value)
<b>TD2</b>	Terminal pin TERMDISC value for the second wire connection (must end with "2")
<b>TINST</b>	Terminal symbol's installation value
<b>TLOC</b>	Terminal symbol's location value
<b>LAYTRM2</b>	Layer of wire connecting to terminal side 2 (must end with "2")
<b>WNUM2</b>	Wire number tied to device component 2 (must end with "2")
<b>CBL2</b>	Cable ID tied to device component 2 (must end with "2")
<b>CBLWC2</b>	Cable wire color tied to device component 2 (must end with "2")
<b>LAYCMP2</b>	Layer of wire connecting to device component 2 (must end with "2")
<b>PD2</b>	"To" device's wire connection TERMDISC value (must end with "2")
<b>PIN2</b>	"To" device's wire connection terminal number (must end with "2")
<b>CMP2</b>	"To" device's component tag ID (must end with "2")
<b>INST2</b>	"To" device's installation code
<b>LOC2</b>	"To" device's location code (must end with "2")

<b>SH</b>	Sheet - the %S value
<b>REF</b>	Line reference or X-Y grid reference or X-Zone reference
<b>HDL</b>	Entity handle number
<b>XDIR1</b>	"From" device's wire connection point direction - i.e. 4 = connects from left (must end with "1")
<b>XDIR2</b>	"To" device's wire connection point direction - i.e. 2 = connects from above (must end with "2")
<b>DWGIX</b>	"From" device's drawing DWGIX value as listed in FILETIME table of project scratch database

## Wire label data fields to report

Changes what data fields are reported and the order in which they appear.

 **Ribbon:** Reports tab ► Schematic panel ► Reports.



 **Toolbar:** Main Electrical 2



 **Menu:** Projects ► Reports ► Schematic Reports

 **Command entry:** AESCHEMATICREPORT

Select Wire Label from the report list. Run the report and click Wire Label on the Report Generator dialog box.

<b>Available Fields</b>	Lists the available fields for formatting the report (including user-defined attributes). Select a field from the list to transfer it into the Fields to Report list.
<b>Fields to Report</b>	Lists the fields to display in the report.
<b>Remove/Remove All</b>	Removes the selected field or all fields from the Fields to Report list.
<b>Move Up</b>	Moves the selected field up one spot in the Fields to Report list.

<b>Move Down</b>	Moves the selected field down one spot in the Fields to Report list.
<b>Separator</b>	<p>Specifies the special character to separate the selected fields. Enter a special character to separate the selected fields inside the list box. Do this by selecting a field from the Fields to Report list, define the separator, select another field, define a separator, and so on. You can also select the separator from a list.</p> <p>The "\n" symbol stands for the new line. When you use this as separator, the field displays in the new (next) line.</p>

### Available Fields

<b>WIRENO</b>	Wire number
<b>CMP</b>	Component that connects to a wire (at any end) and is written to the wire label
<b>PIN</b>	Wire connection terminal pin number of the component that the wire connects with

### Wire conduit routing data fields to display

Changes what data fields are reported and the order in which they appear.

 **Ribbon:** Panel tab ► Conduit Tools panel ► Conduit Reports drop-down

► Routing Report. 

 **Toolbar:** Conduit Reports 

 **Menu:** Panel Layout ► Conduit Marker Tools ► Wire/Conduit Routing Report

 **Command entry:** AEROUTINGREPORT

Run the report and click Change Report Format on the Report Generator dialog box.

<b>Available Fields</b>	Lists the available fields for formatting the report (including user-defined attributes). Select a field from the list to transfer it into the Fields to Report list.
-------------------------	---

<b>Fields to Report</b>	Lists the fields to display in the report.
<b>Remove/Remove All</b>	Removes the selected field or all fields from the Fields to Report list.
<b>Move Up</b>	Moves the selected field up one spot in the Fields to Report list.
<b>Move Down</b>	Moves the selected field down one spot in the Fields to Report list.
<b>Change field name/justification</b>	Specifies the vertical and horizontal justification (Top Left, Middle Center, Bottom Right) of any column and the column label (default is Top Left). The vertical portion of the justification (Top, Middle, Bottom) is only used for the Put on Drawing report feature. For example, if you select "Top Right" the report is right-justified during the display, printing and when saved to a file (the "top" portion is ignored). If you put the report on the drawing, the report justification is top right.

#### **Available Fields**

<b>CBL</b>	Cable tag
<b>CBLWC</b>	Cable wire or cable core color
<b>WIRENO</b>	Wire number
<b>INST1</b>	"From" device's installation code (must end with "1")
<b>LOC1</b>	"From" device's location code (must end with "1")
<b>CMP1</b>	"From" device's component tag ID (must end with "1")
<b>PIN1</b>	"From" device's wire connection terminal number (must end with "1")
<b>INST2</b>	"To" device's installation code (must end with "2")
<b>LOC2</b>	"To" device's location code (must end with "2")
<b>CMP2</b>	"To" device's component tag ID (must end with "2")

<b>PIN2</b>	"To" device's wire connection terminal number (must end with "2")
<b>WLAY</b>	Wire layer name
<b>ROUTING</b>	Conduit routing path description

## Cross-reference table data fields to display

Changes what data fields are reported and the order in which they appear.

 **Ribbon:** Project tab ► Project Tools panel ► Manager. 

 **Toolbar:** Main Electrical 2 

 **Menu:** Projects ► Project ► Project Manager

 **Command entry:** AEPROJECT

In the Project Manager, right-click the project or drawing name and select Properties. Click the Cross-references tab. In the component Cross-reference Display section, select Table Format and click Setup. In the Table Cross-reference Format Setup dialog box, Table Style section, click Define Columns.

---

**NOTE** This can also be accessed from the Insert/Edit Component, Cross-reference section. Select Component override and click Setup. In the Cross-reference component override dialog box, select Table Format and click Setup.

---

<b>Available Fields</b>	Lists the available fields for formatting the report (including user-defined attributes). Select a field from the list to transfer it into the Fields to Report list.
<b>Fields to Report</b>	Lists the fields to display in the report.
<b>Remove/Remove All</b>	Removes the selected field or all fields from the Fields to Report list.
<b>Move Up</b>	Moves the selected field up one spot in the Fields to Report list.



<b>Move Down</b>	Moves the selected field down one spot in the Fields to Report list.
<b>Change field name/justification</b>	Specifies the vertical and horizontal justification (Top Left, Middle Center, Bottom Right) of any column and the column label (default is Top Left). The vertical portion of the justification (Top, Middle, Bottom) is only used for the Put on Drawing report feature. For example, if you select "Top Right" the report is right-justified during the display, printing and when saved to a file (the "top" portion is ignored). If you put the report on the drawing, the report justification is top right.

### Available Fields

<b>W1</b>	Wire number - first wire connection on symbol (TERM01)
<b>T1</b>	Terminal pin number - first wire connection (TERM01)
<b>TYPE</b>	Contact type - can be user defined and come from the Contact attribute on the child symbol - this gets overwritten from the contact mapping in the dialog box
<b>T2</b>	Terminal pin number - second wire connection (TERM02)
<b>W2</b>	Wire number - second wire connection (TERM02)
<b>REF</b>	Line reference or X-Y grid reference or X-Zone reference
<b>SH</b>	Sheet - the %S value
<b>SHDWGNAM</b>	Drawing name - the %D value
<b>FILENAME</b>	AutoCAD drawing file name (.dwg)
<b>FULLFILENAME</b>	AutoCAD drawing file name (.dwg) with complete path

### Data fields to display

Changes what data fields are reported and the order in which they appear.

 **Ribbon:** Schematic tab ► Edit Components panel ► Modify Component



Cross-Reference drop-down ► Cross-Reference Table.

 **Menu:** Components ► Cross-Reference ► Cross-Reference Table

 **Command entry:** AESHOWXREFTABLE

Select the component to evaluate. Click Change Report Format on the Report Generator dialog box.

<b>Available Fields</b>	Lists the available fields for formatting the report (including user-defined attributes). Select a field from the list to transfer it into the Fields to Report list.
<b>Fields to Report</b>	Lists the fields to display in the report.
<b>Remove/Remove All</b>	Removes the selected field or all fields from the Fields to Report list.
<b>Move Up</b>	Moves the selected field up one spot in the Fields to Report list.
<b>Move Down</b>	Moves the selected field down one spot in the Fields to Report list.
<b>Change field name/justification</b>	Specifies the vertical and horizontal justification (Top Left, Middle Center, Bottom Right) of any column and the column label (default is Top Left). The vertical portion of the justification (Top, Middle, Bottom) is only used for the Put on Drawing report feature. For example, if you select "Top Right" the report is right-justified during the display, printing and when saved to a file (the "top" portion is ignored). If you put the report on the drawing, the report justification is top right.

#### Available Fields

<b>W1</b>	Wire number - first wire connection on symbol (TERM01)
<b>T1</b>	Terminal pin number - first wire connection (TERM01)

<b>TYPE</b>	Contact type - can be user defined and come from the Contact attribute on the child symbol - this gets overwritten from the contact mapping in the dialog box
<b>T2</b>	Terminal pin number - second wire connection (TERM02)
<b>W2</b>	Wire number - second wire connection (TERM02)
<b>REF</b>	Line reference or X-Y grid reference or X-Zone reference
<b>SH</b>	Sheet - the %S value
<b>SHDWGNAM</b>	Drawing name - the %D value
<b>FILENAME</b>	AutoCAD drawing file name (.dwg)
<b>FULLFILENAME</b>	AutoCAD drawing file name (.dwg) with complete path

## Schematic Reports

### Generate schematic reports

AutoCAD Electrical has multiple schematic reports that you can run.

#### Bill of Materials reports

The Bill of Material reports report only components with assigned BOM information. These reports provide the following BOM-related features:

- Extract BOM reports on demand, active drawing, or project-wide
- Extract BOM reports on a per-location basis
- Change BOM report format
- Output BOM reports to ASCII report file
- Export BOM data to a spreadsheet or database program
- Insert BOM as a table right on an AutoCAD drawing
- List parent or stand-alone components without catalog information

### **Component report**

This report performs a project-wide extract of all components found on your wiring diagram set. This data includes component tags, location codes, location reference, description text, ratings, catalog information, and block names.

### **Wire From/To report**

If you marked components and/or terminals with location codes, you can make good use of this report. This report first extracts component, terminal, location code, and wire connection information from every drawing in the project set. Then it displays a location list dialog box where you can make your report's "from" and "to" location selections. All the location codes AutoCAD Electrical found on the drawing set are listed on each side of this dialog box. Location "(?)" is also included in the list if AutoCAD Electrical found any component or stand-alone terminal that did not have an assigned location code.

### **Component Wire List report**

This report extracts the component wire connection data and displays it in a dialog box. Each entry shows a connection to a component, the wire number, component tag name, terminal pin number, component location code (if present), and the layer that the connected wire is on.

### **Connector Plug report**

This report extracts plug/jack connection reports and optionally generates pin charts. Since each wire tied to each connector pin displays in the report, each pin has two entries. One entry is for the 'in' wire and the other is for the 'out' wire. To create a more useful report, select the PIN chart 'on' radio button at the bottom of the Report Generator dialog box. Make sure the Remove duplicated pin numbers toggle is checked and click OK. It reformats the report so each pin is listed only once.

### **PLC I/O Address and Description report**

This report lists each PLC module and its beginning and ending I/O address numbers. It scans your drawing set and returns all individual I/O connection points it finds. It includes up to five lines of description text and the connected wire number for each I/O point.

### **PLC I/O Component Connection report**

This report scans the selected drawings and returns information about any components connected to PLC I/O points. Data for the report starts at each

wire connection point and follows the connected wire. The first terminal symbol, fuse symbol, or connector symbol that is hit reports in the column marked with default "TERMTAG" label. The first schematic component reports in the column with the "CMPTAG" label. If there are multiple instances, the one closest to the PLC I/O point is the one that shows up in the report column.

#### **PLC Modules Used So Far report**

For this report, AutoCAD Electrical quickly scans the wiring diagram set. It returns in a few moments and displays the I/O modules it finds. Each entry shows the beginning and ending address of the module.

#### **Terminal Numbers report**

This project-wide, stand-alone report lists all instances of terminals. Each entry includes information tied directly to the terminal such as terminal number, terminal strip number, and location code.

#### **Terminal Plan report**

This project-wide, stand-alone report does a wire network extraction. It takes longer to generate, but the report includes wire number and wire layer name information.

#### **Connector Summary report**

This report lists a single line for each connector tag along with pins used, maximum pins allowed (if the parent carries the PINLIST information), and a list of any repeated pin numbers used. You can run this report across the project or for a single component.

#### **Connector Details report**

This report extracts the component wire connection data and displays it in a dialog box. Each entry shows a connection to a component, the wire number, component tag name, terminal pin number, component location code (if present), and the layer that the connected wire is on.

#### **Cable Summary report**

This project-wide cable conductor report gives a report listing all the cable marker tags (parent tags) found.

### **Cable From/To report**

This project-wide cable conductor report lists the "from / to" for each cable conductor. It also lists the parent cable number of the conductor, conductor color code, and wire number (if present).

### **Wire Label report**

This report lists wire markers/labels and can be used to create physical wire or cable labels.

### **Generate a schematic report**

Generates schematic reports, such as Bills of Material, Component lists, Wire From/To, and PLC descriptions.

Select which drawings to process. The report displays options to:

- Change included fields.
- Add or modify data.
- Print.
- Save to a file.
- Put on the drawings as table objects.





- 1 Click Reports tab ► Schematic panel ► Reports.
- 2 Select which schematic report to generate from the report list.
- 3 Select to process the project, current drawing, or selected components.
- 4 Specify any report options (if applicable).
- 5 Select installation or location codes to extract (if applicable).
- 6 Indicate whether to update the project database or the wire connection table with out-of-date drawings.
- 7 Click OK.

- 8 In the Report Generator Window, sort, format, or edit the data before sending the information to the printer, file, or the active drawing file.
  - **Edit Mode:** Modifies the report before you insert it to your drawing. You can move data up or down in the report, add lines from a catalog, and delete lines.
  - **Put on Drawing:** Opens the Table Generation Setup dialog box for specifying how to display your report as a table on your drawing.
  - **Save to File:** Saves the report to a file. Select the type of output file from the Save Report to File dialog box. You can define multiple file outputs. Choose from: ASCII report, Comma Delimited, Excel spreadsheet, Access database, and XML format.
  - **User Post:** Switch specific functions against the data in the report. When you select a switch, the LISP routine runs a function against the data and returns to the Report Generator Window.
  - **Change Report Format:** Changes what data fields are reported and the order in which they appear. You can change the justification of any column and the column label. The Description field can be multi-lined. If you include the Description field in your report, you choose which lines make up this field. Switch on and off the specific fields to define the Description.
- 9 Once all modifications have been made to the report, save the report, place the report on the drawing as a table, or print the report.

## Schematic bill of material

The Bill of Material reports report only components with assigned BOM information.

 **Ribbon:** Reports tab ► Schematic panel ► Reports. 

 **Toolbar:** Main Electrical 2 

 **Menu:** Projects ► Reports ► Schematic Reports

 **Command entry:** AESCHEMATICREPORT

Select Bill of Material from the report list.

Specify whether to process the project or the active drawing.

## Category

By default, the report lists schematic components. Select a different Category to run the report for one-line, one-line bus-tap, hydraulic, pneumatic, P&ID, or user-defined components. These components are each identified by a unique [WDTYPE attribute](#) on page 325 value.

## Include options

<b>Include Cables</b>	Specifies to include cable information in the report.
<b>Include Connectors</b>	Specifies to include connector information in the report.
<b>Include Jumpers</b>	Specifies to include jumper information in the report.
<b>All the above</b>	Specifies to cable, connector, and jumper information in the report.
<b>List terminal numbers</b>	Lists each individual Tag-ID and terminal number combination if selected. If unselected (default), the terminals are combined on the same Tag-ID strip into a single entry with a quantity.

## Display option

<b>Normal Tallied Format</b>	Identical component or component/assemblies are tallied and reported as single line items (example: Red push-button operator 800EP-F4 with 800E-A3L latch and two 800E-3X10 N.O. contact blocks).
<b>Normal Tallied Format (Group by Installation/Location)</b>	Identical component or component/assemblies with the same installation/location codes are tallied and reported as single line items.
<b>Display in Tallied Purchase List Format</b>	Each part becomes its own line item (example: no longer any sub-assembly items) and each is tallied across all component types. For example, all 800E-3X10 N.O. contact blocks for all components are reported as a single line item.



**Display in By TAG Format**

All instances of a given component-ID or terminal tag are processed together and then reported as a single entry.

**Installation Codes to Extract**

Extracts only the information for components with specific installation values. Indicate to process all components that carry part number values, components without an installation code, or only components marked with a location code that matches that entered in the edit box. Wild-cards are supported.

Once you pick Named Installation, type the installation code in the box or click List: Drawing or List: Project to select from a list of used installation codes. You can also create a report from multiple installation codes. AutoCAD Electrical automatically creates a comma-delimited list for the named installation search.

**Location Codes to Extract**

Extracts only the information for components with specific location values. Indicate to process all components that carry part number values, components without a location code, or only components marked with a location code that matches that entered in the edit box. For example, BOM report for components marked "OP STA 2". Wild-cards are supported.

Once you pick Named Location, type the location code in the box or click List: Drawing or List: Project to select from a list of used location codes. You can also create a report from multiple location codes. AutoCAD Electrical automatically creates a comma-delimited list for the named location search.

**Freshen Project Database**

Specifies for AutoCAD Electrical to update the project database to include any out-of-date drawing files.

**Format**

Changes the format of the extracted data. The subdialog box lists the format files to select from.

**Schematic cable summary**

This project-wide cable conductor report gives a report listing all of the cable marker tags (parent tags) found.

 **Ribbon:** Reports tab ► Schematic panel ► Reports.

 **Toolbar:** Main Electrical 2

**Menu:** Projects ► Reports ► Schematic Reports

**Command entry:** AESCHEMATICREPORT

Select Cable Summary from the report list.

### Category

By default, the report lists schematic components. Select a different Category to run the report for one-line, one-line bus-tap, hydraulic, pneumatic, P&ID, or user-defined components. These components are each identified by a unique [WDTYPE attribute](#) on page 325 value.

### Installation Codes to Extract

Extracts only the information for components with specific installation values. Indicate to process all components that carry part number values, components without an installation code, or only components marked with a location code that matches that entered in the edit box. Wild-cards are supported.

Once you pick Named Installation, type the installation code in the box or click List: Drawing or List: Project to select from a list of used installation codes. You can also create a report from multiple installation codes. AutoCAD Electrical automatically creates a comma-delimited list for the named installation search.

### Location Codes to Extract

Extracts only the information for components with specific location values. Indicate to process all components that carry part number values, components without a location code, or only components marked with a location code that matches that entered in the edit box. For example, BOM report for components marked "OP STA 2". Wild-cards are supported.

Once you pick Named Location, type the location code in the box or click List: Drawing or List: Project to select from a list of used location codes. You can also create a report from multiple location codes. AutoCAD Electrical automatically creates a comma-delimited list for the named location search.

### Freshen Project Database



Specifies for AutoCAD Electrical to update the project database to include any out-of-date drawing files.

### Format

Changes the format of the extracted data. The subdialog box lists the format files to select from.

### Schematic cable from/to

This project-wide cable conductor report lists the "from / to" for each cable conductor. It also lists the parent cable number of the conductor, conductor color code, and wire number (if present).

 **Ribbon:** Reports tab ► Schematic panel ► Reports. 

 **Toolbar:** Main Electrical 2 

 **Menu:** Projects ► Reports ► Schematic Reports

 **Command entry:** AESCHEMATICREPORT

Select Cable From/To from the report list.

Specify whether to process the project, the active drawing, or selected cables.

### Category

By default, the report lists schematic components. Select a different Category to run the report for one-line, one-line bus-tap, hydraulic, pneumatic, P&ID, or user-defined components. These components are each identified by a unique [WDTYPE attribute](#) on page 325 value.

### Freshen Project Database



Specifies for AutoCAD Electrical to update the project database to include any out-of-date drawing files.



### Format

Changes the format of the extracted data. The dialog box lists the format files to select from.

### Schematic PLC I/O component connection

This report scans the selected drawings and returns information about any components connected to PLC I/O points. Data for the report starts at each wire connection point and follows the connected wire. The first terminal symbol, fuse symbol, or connector symbol that is hit reports in the column marked with default "TERMTAG" label. The first schematic component reports in the column with the "CMPTAG" label. If there are multiple instances, the one closest to the PLC I/O point is the one that shows up in the report column.

 **Ribbon:** Reports tab ► Schematic panel ► Reports. 

 **Toolbar:** Main Electrical 2 

 **Menu:** Projects ► Reports ► Schematic Reports

 **Command entry:** AESCHEMATICREPORT

Select PLC I/O Component Connection from the report list.

Specify whether to process the project or the active drawing.

### Installation Codes to Extract

Extracts only the information for components with specific installation values. Indicate to process all components that carry part number values, components without an installation code, or only components marked with a location code that matches that entered in the edit box. Wild-cards are supported.

Once you pick Named Installation, type the installation code in the box or click List: Drawing or List: Project to select from a list of used installation codes. You can also create a report from multiple installation codes. AutoCAD Electrical automatically creates a comma-delimited list for the named installation search.

### Location Codes to Extract

Extracts only the information for components with specific location values. Indicate to process all components that carry part number values, components without a location code, or only components marked with a location code that matches that entered in the edit box. For example, BOM report for components marked "OP STA 2". Wild-cards are supported.

Once you pick Named Location, type the location code in the box or click List: Drawing or List: Project to select from a list of used location codes. You

can also create a report from multiple location codes. AutoCAD Electrical automatically creates a comma-delimited list for the named location search.

### List

Lists drawings that appear to be out-of-date with the wire connection table of the project.

### Freshen Wire Connection Table



Specifies for AutoCAD Electrical to update the wire connection table to include any out-of-date drawing files.

### Format

Changes the format of the extracted data. The subdialog box lists the format files to select from.

## Schematic component wire list

This report extracts the component wire connection data and shows it in a dialog box. Each entry shows a connection to a component, the wire number, component tag name, terminal pin number, component location code (if present), and the layer that the connected wire is on.

 **Ribbon:** Reports tab ► Schematic panel ► Reports. 

 **Toolbar:** Main Electrical 2 

 **Menu:** Projects ► Reports ► Schematic Reports

 **Command entry:** AESCHEMATICREPORT

Select Component Wire List from the report list.

Specify whether to process the project, active drawing, or select components.

### Options

Specifies to include stand-alone terminals or plug-jack connectors in the report.

### Installation Codes to Extract

Extracts only the information for components with specific installation values. Indicate to process all components that carry part number values, components

without an installation code, or only components marked with a location code that matches that entered in the edit box. Wild-cards are supported.

Once you pick Named Installation, type the installation code in the box or click List: Drawing or List: Project to select from a list of used installation codes. You can also create a report from multiple installation codes. AutoCAD Electrical automatically creates a comma-delimited list for the named installation search.

### **Location Codes to Extract**

Extracts only the information for components with specific location values. Indicate to process all components that carry part number values, components without a location code, or only components marked with a location code that matches that entered in the edit box. For example, BOM report for components marked "OP STA 2". Wild-cards are supported.

Once you pick Named Location, type the location code in the box or click List: Drawing or List: Project to select from a list of used location codes. You can also create a report from multiple location codes. AutoCAD Electrical automatically creates a comma-delimited list for the named location search.

### **List**

Lists drawings that appear to be out-of-date with the wire connection table of the project.

### **Freshen Wire Connection Table**

Specifies for AutoCAD Electrical to update the wire connection table to include any out-of-date drawing files.

### **Format**

Changes the format of the extracted data. The subdialog box lists the format files to select from.

## **Schematic connector details**

AutoCAD Electrical extracts the component wire connection data and displays it in a dialog box. Each entry shows a connection to a component, the wire number, component tag name, terminal pin number, component location code (if present), and the layer that the connected wire is on.

 **Ribbon:** Reports tab ► Schematic panel ► Reports.





 **Toolbar:** Main Electrical 2

 **Menu:** Projects ► Reports ► Schematic Reports

 **Command entry:** AESCHEMATICREPORT

Select Connector Details from the report list.

Specify whether to process the project or a single pick.

### Category

By default, the report lists schematic components. Select a different Category to run the report for one-line, one-line bus-tap, hydraulic, pneumatic, P&ID, or user-defined components. These components are each identified by a unique [WDTYPE attribute](#) on page 325 value.

### Installation Codes to Extract

Extracts only the information for components with specific installation values. Indicate to process all components that carry part number values, components without an installation code, or only components marked with a location code that matches that entered in the edit box. Wild cards are supported.

After you click Named Installation, type the installation code in the box, or click List: Drawing or List: Project to select from a list of used installation codes. You can also create a report from multiple installation codes. AutoCAD Electrical automatically creates a comma-delimited list for the named installation search.

### Location Codes to Extract

Extracts only the information for components with specific location values. Indicate to process all components that carry part number values, components without a location code, or only components marked with a location code that matches that entered in the edit box. For example, BOM report for components marked "OP STA 2". Wild cards are supported.

After you click Named Location, type the location code in the box, or click List: Drawing or List: Project to select from a list of used location codes. You can also create a report from multiple location codes. AutoCAD Electrical automatically creates a comma-delimited list for the named location search.

## Freshen Project Database



Specifies for AutoCAD Electrical to update the project database to include any out-of-date drawing files.

## Format

Changes the format of the extracted data. The dialog box lists the format files to select from.

## Schematic connector plug

This report extracts plug/jack connection reports and optionally generates pin charts. Since each wire tied to each connector pin displays in the report, each pin has two entries - one for the 'in' wire and one for the 'out' wire. To create a more useful report, select the PIN chart 'on' radio button at the bottom of the Report Generator dialog box. Make sure the Remove duplicated pin numbers toggle is checked and click OK. It reformats the report so each pin is listed only once.

 **Ribbon:** Reports tab ► Schematic panel ► Reports. 

 **Toolbar:** Main Electrical 2 

 **Menu:** Projects ► Reports ► Schematic Reports

 **Command entry:** AESCHEMATICREPORT

Select Connector Plug from the report list.

Specify whether to process the project, the active drawing, or selected wires.

## Category

By default, the report lists schematic components. Select a different Category to run the report for one-line, one-line bus-tap, hydraulic, pneumatic, P&ID, or user-defined components. These components are each identified by a unique [WDTYPE attribute](#) on page 325 value.

## Installation Codes to Extract

Extracts only the information for components with specific installation values. Indicate to process all components that carry part number values, components without an installation code, or only components marked with a location code that matches that entered in the edit box. Wild cards are supported.



After you click Named Installation, type the installation code in the box, or click List: Drawing or List: Project to select from a list of used installation codes. You can also create a report from multiple installation codes. AutoCAD Electrical automatically creates a comma-delimited list for the named installation search.

### **Location Codes to Extract**

Extracts only the information for components with specific location values. Indicate to process all components that carry part number values, components without a location code, or only components marked with a location code that matches that entered in the edit box. For example, BOM report for components marked "OP STA 2." Wild cards are supported.

After you click Named Location, type the location code in the box, or click List: Drawing or List: Project to select from a list of used location codes. You can also create a report from multiple location codes. AutoCAD Electrical automatically creates a comma-delimited list for the named location search.

### **List**

Lists drawings that appear to be out-of-date with the wire connection table of the project.

### **Freshen Wire Connection Table**

Specifies for AutoCAD Electrical to update the wire connection table to include any out-of-date drawing files.

### **Format**

Changes the format of the extracted data. The dialog box lists the format files to select from.



## **Schematic connector summary**

This report lists a single line for each connector tag along with pins used, maximum pins allowed (if the parent carries the PINLIST information), and a list of any repeated pin numbers used. You can run this report across the project or for a single component.

 **Ribbon:** Reports tab ► Schematic panel ► Reports.





-  **Toolbar:** Main Electrical 2
-  **Menu:** Projects ► Reports ► Schematic Reports
-  **Command entry:** AESCHEMATICREPORT

Select Connector Summary from the report list.

Specify whether to process the project or a single pick.

### Category

By default, the report lists schematic components. Select a different Category to run the report for one-line, one-line bus-tap, hydraulic, pneumatic, P&ID, or user-defined components. These components are each identified by a unique [WDTYPE attribute](#) on page 325 value.

### Installation Codes to Extract

Extracts only the information for components with specific installation values. Indicate to process all components that carry part number values, components without an installation code, or only components marked with a location code that matches that entered in the edit box. Wild cards are supported.

After you click Named Installation, type the installation code in the box, or click List: Drawing or List: Project to select from a list of used installation codes. You can also create a report from multiple installation codes. AutoCAD Electrical automatically creates a comma-delimited list for the named installation search.

### Location Codes to Extract

Extracts only the information for components with specific location values. Indicate to process all components that carry part number values, components without a location code, or only components marked with a location code that matches that entered in the edit box. For example, BOM report for components marked "OP STA 2." Wild cards are supported.

After you click Named Location, type the location code in the box, or click List: Drawing or List: Project to select from a list of used location codes. You can also create a report from multiple location codes. AutoCAD Electrical automatically creates a comma-delimited list for the named location search.

## Freshen Project Database

Specifies for AutoCAD Electrical to update the project database to include any out-of-date drawing files.

## Format

Changes the format of the extracted data. The dialog box lists the format files to select from.

## Schematic component

This report extracts the component wire connection data and displays it in a dialog box. Each entry shows a connection to a component, the wire number, component tag name, terminal pin number, component location code (if present), and the layer that the connected wire is on.

 **Ribbon:** Reports tab ► Schematic panel ► Reports.

 **Toolbar:** Main Electrical 2

**Menu:** Projects ► Reports ► Schematic Reports

**Command entry:** AESCHEMATICREPORT

Select Component from the report list.

Specify whether to process the project or the active drawing.

## Category

By default, the report lists schematic components. Select a different Category to run the report for one-line, one-line bus-tap, hydraulic, pneumatic, P&ID, or user-defined components. These components are each identified by a unique [WDTYPE attribute](#) on page 325 value.

## Options

Specifies to include components, cable markers, or connectors in the report. You can also indicate to include the children for the selected options.

## Installation Codes to Extract

Extracts only the information for components with specific installation values. Indicate to process all components that carry part number values, components

without an installation code, or only components marked with a location code that matches that entered in the edit box. Wild cards are supported.

After you click Named Installation, type the installation code in the box, or click List: Drawing or List: Project to select from a list of used installation codes. You can also create a report from multiple installation codes. AutoCAD Electrical automatically creates a comma-delimited list for the named installation search.

### **Location Codes to Extract**

Extracts only the information for components with specific location values. Indicate to process all components that carry part number values, components without a location code, or only components marked with a location code that matches that entered in the edit box. For example, BOM report for components marked "OP STA 2." Wild cards are supported.

After you click Named Location, type the location code in the box, or click List: Drawing or List: Project to select from a list of used location codes. You can also create a report from multiple location codes. AutoCAD Electrical automatically creates a comma-delimited list for the named location search.

### **Freshen Project Database**

Specifies for AutoCAD Electrical to update the project database to include any out-of-date drawing files.

### **Format**

Changes the format of the extracted data. The dialog box lists the format files to select from.

## **Schematic missing bill of material**

Extracts the information from the active drawing or project and displays a list of parent or stand-alone components without catalog information.

 **Ribbon:** Reports tab ► Schematic panel ► Reports.



 **Toolbar:** Main Electrical 2



 **Menu:** Projects ► Reports ► Schematic Reports

 **Command entry:** AESCHEMATICREPORT

Select Missing Bill of Material from the report list.

Specify whether to process the project or the active drawing.

### **Category**

By default, the report lists schematic components. Select a different Category to run the report for one-line, one-line bus-tap, hydraulic, pneumatic, P&ID, or user-defined components. These components are each identified by a unique [WDTYPE attribute](#) on page 325 value.

### **Options**

Specifies to include components, cable markers, connectors, or terminals in the report.

### **Installation Codes to Extract**

Extracts only the information for components with specific installation values. Indicate to process all components that carry part number values, components without an installation code, or only components marked with a location code that matches that entered in the edit box. Wild cards are supported.

After you click Named Installation, type the installation code in the box, or click List: Drawing or List: Project to select from a list of used installation codes. You can also create a report from multiple installation codes. AutoCAD Electrical automatically creates a comma-delimited list for the named installation search.

### **Location Codes to Extract**

Extracts only the information for components with specific location values. Indicate to process all components that carry part number values, components without a location code, or only components marked with a location code that matches that entered in the edit box. For example, BOM report for components marked "OP STA 2." Wild cards are supported.

After you click Named Location, type the location code in the box, or click List: Drawing or List: Project to select from a list of used location codes. You can also create a report from multiple location codes. AutoCAD Electrical automatically creates a comma-delimited list for the named location search.

### **Freshen Project Database**



Specifies for AutoCAD Electrical to update the project database to include any out-of-date drawing files.

## Format

Changes the format of the extracted data. The dialog box lists the format files to select from.

## Schematic wire from/to

If you marked components and/or terminals with location codes, you can make good use of this report. AutoCAD Electrical first extracts component, terminal, location code, and wire connection information from every drawing in the project set. Then it displays a location list dialog box where you can make your report's "from" and "to" location selections. All the location codes AutoCAD Electrical found on the drawing set are listed on each side of this dialog box. Location "(?)" is also included in the list if AutoCAD Electrical found any component or stand-alone terminal that didn't have an assigned location code.

 **Ribbon:** Reports tab ► Schematic panel ► Reports. 

 **Toolbar:** Main Electrical 2 

 **Menu:** Projects ► Reports ► Schematic Reports

 **Command entry:** AESCHEMATICREPORT

Select Wire From/To from the report list.

Specify whether to process the project, the active drawing, or selected wires.

## Category

By default, the report lists schematic components. Select a different Category to run the report for one-line, one-line bus-tap, hydraulic, pneumatic, P&ID, or user-defined components. These components are each identified by a unique [WDTYPE attribute](#) on page 325 value.

## List

Lists drawings that appear to be out-of-date with the wire connection table of the project.

## Freshen Wire Connection Table



Specifies for AutoCAD Electrical to update the wire connection table to include any out-of-date drawing files.

## Format

Changes the format of the extracted data. The dialog box lists the format files to select from.

## Schematic PLC I/O address and descriptions

This report lists each PLC module and its beginning and ending I/O address numbers. It scans your drawing set and returns all individual I/O connection points it finds. It includes up to five lines of description text and the connected wire number for each I/O point.

 **Ribbon:** Reports tab > Schematic panel > Reports. 

 **Toolbar:** Main Electrical 2 

 **Menu:** Projects > Reports > Schematic Reports

 **Command entry:** AESCHEMATICREPORT

Select PLC I/O Address and Descriptions from the report list.

### Installation Codes to Extract

Extracts only the information for components with specific installation values. Indicate to process all components that carry part number values, components without an installation code, or only components marked with a location code that matches that entered in the edit box. Wild cards are supported.

After you click Named Installation, type the installation code in the box, or click List: Drawing or List: Project to select from a list of used installation codes. You can also create a report from multiple installation codes. AutoCAD Electrical automatically creates a comma-delimited list for the named installation search.

### Location Codes to Extract

Extracts only the information for components with specific location values. Indicate to process all components that carry part number values, components without a location code, or only components marked with a location code that matches that entered in the edit box. For example, BOM report for components marked "OP STA 2." Wild cards are supported.

After you click Named Location, type the location code in the box, or click List: Drawing or List: Project to select from a list of used location codes. You

can also create a report from multiple location codes. AutoCAD Electrical automatically creates a comma-delimited list for the named location search.

### **Freshen Project Database**



Specifies for AutoCAD Electrical to update the project database to include any out-of-date drawing files.

### **Format**

Changes the format of the extracted data. The dialog box lists the format files to select from.

## **Schematic terminal numbers**

This project-wide, stand-alone report lists all instances of terminals. Each entry includes information tied directly to the terminal such as terminal number, terminal strip number, and location code.

 **Ribbon:** Reports tab ► Schematic panel ► Reports. 

 **Toolbar:** Main Electrical 2 

 **Menu:** Projects ► Reports ► Schematic Reports

 **Command entry:** AESCHEMATICREPORT

Select Terminal Numbers from the report list.

Specify whether to process the project or the active drawing.

### **Installation Codes to Extract**

Extracts only the information for components with specific installation values. Indicate to process all components that carry part number values, components without an installation code, or only components marked with a location code that matches that entered in the edit box. Wild cards are supported.

After you click Named Installation, type the installation code in the box, or click List: Drawing or List: Project to select from a list of used installation codes. You can also create a report from multiple installation codes. AutoCAD Electrical automatically creates a comma-delimited list for the named installation search.



### Location Codes to Extract

Extracts only the information for components with specific location values. Indicate to process all components that carry part number values, components without a location code, or only components marked with a location code that matches that entered in the edit box. For example, BOM report for components marked "OP STA 2." Wild cards are supported.

After you click Named Location, type the location code in the box, or click List: Drawing or List: Project to select from a list of used location codes. You can also create a report from multiple location codes. AutoCAD Electrical automatically creates a comma-delimited list for the named location search.

### Freshen Project Database



Specifies for AutoCAD Electrical to update the project database to include any out-of-date drawing files.

### Format

Changes the format of the extracted data. The dialog box lists the format files to select from.

## Schematic terminal plan

This project-wide, stand-alone report does a wire network extraction. It takes longer to generate, but the report includes wire number and wire layer name information.

 **Ribbon:** Reports tab > Schematic panel > Reports. 

 **Toolbar:** Main Electrical 2 

 **Menu:** Projects > Reports > Schematic Reports

 **Command entry:** AESCHEMATICREPORT

Select Terminal Plan from the report list.

Specify whether to process the project, active drawing, or select components.

### Installation Codes to Extract

Extracts only the information for components with specific installation values. Indicate to process all components that carry part number values, components

without an installation code, or only components marked with a location code that matches that entered in the edit box. Wild cards are supported.

After you click Named Installation, type the installation code in the box, or click List: Drawing or List: Project to select from a list of used installation codes. You can also create a report from multiple installation codes. AutoCAD Electrical automatically creates a comma-delimited list for the named installation search.

### **Location Codes to Extract**

Extracts only the information for components with specific location values. Indicate to process all components that carry part number values, components without a location code, or only components marked with a location code that matches that entered in the edit box. For example, BOM report for components marked "OP STA 2." Wild cards are supported.

After you click Named Location, type the location code in the box, or click List: Drawing or List: Project to select from a list of used location codes. You can also create a report from multiple location codes. AutoCAD Electrical automatically creates a comma-delimited list for the named location search.

### **List**

Lists drawings that appear to be out-of-date with the wire connection table of the project.

### **Freshen Wire Connection Table**

Specifies for AutoCAD Electrical to update the wire connection table to include any out-of-date drawing files.

### **Format**

Changes the format of the extracted data. The dialog box lists the format files to select from.

## **Schematic PLC modules used so far**

For the PLC Modules Used So Far report, AutoCAD Electrical quickly scans the wiring diagram set. It returns in a few moments and displays the I/O modules it finds. Each entry shows the beginning and ending address of the module.

 **Ribbon:** Reports tab ► Schematic panel ► Reports.





 **Toolbar:** Main Electrical 2

 **Menu:** Projects ► Reports ► Schematic Reports

 **Command entry:** AESCHEMATICREPORT

Select PLC Modules Used So Far from the report list.

### **Installation Codes to Extract**

Extracts only the information for components with specific installation values. Indicate to process all components that carry part number values, components without an installation code, or only components marked with a location code that matches that entered in the edit box. Wild-cards are supported.

After you click Named Installation, type the installation code in the box, or click List: Drawing or List: Project to select from a list of used installation codes. You can also create a report from multiple installation codes. AutoCAD Electrical automatically creates a comma-delimited list for the named installation search.

### **Location Codes to Extract**

Extracts only the information for components with specific location values. Indicate to process all components that carry part number values, components without a location code, or only components marked with a location code that matches that entered in the edit box. For example, BOM report for components marked "OP STA 2." Wild cards are supported.

After you click Named Location, type the location code in the box, or click List: Drawing or List: Project to select from a list of used location codes. You can also create a report from multiple location codes. AutoCAD Electrical automatically creates a comma-delimited list for the named location search.

### **Freshen Project Database**

Specifies for AutoCAD Electrical to update the project database to include any out-of-date drawing files.

### **Format**

Changes the format of the extracted data. The dialog box lists the format files to select from.

## **Schematic wire label**

This report lists wire markers/labels and can be used to create physical wire or cable labels.

 **Ribbon:** Reports tab ► Schematic panel ► Reports.



 **Toolbar:** Main Electrical 2



 **Menu:** Projects ► Reports ► Schematic Reports

 **Command entry:** AESCHEMATICREPORT

Select Wire Label from the report list.

Specify whether to process the project, the active drawing, or selected wires.

---

**NOTE** If you select Active drawing (pick), click the wire rather than the wire number.

---

### Installation Codes to Extract

Extracts only the information for components with specific installation values. Indicate to process all components that carry part number values, components without an installation code, or only components marked with a location code that matches that entered in the edit box. Wildcards are supported.

Once you pick Named Installation, type the installation code in the box or click List: Drawing or List: Project to select from a list of used installation codes. You can also create a report from multiple installation codes. AutoCAD Electrical automatically creates a comma-delimited list for the named installation search.

### Location Codes to Extract

Extracts only the information for components with specific location values. Indicate to process all components that carry part number values, components without a location code, or only components marked with a location code that matches that entered in the edit box. For example, BOM report for components marked "OP STA 2". Wild-cards are supported.

Once you pick Named Location, type the location code in the box or click List: Drawing or List: Project to select from a list of used location codes. You can also create a report from multiple location codes. AutoCAD Electrical automatically creates a comma-delimited list for the named location search.

## List

Lists drawings that appear to be out-of-date with the wire connection table of the project.

## Freshen Wire Connection Table

Specifies for AutoCAD Electrical to update the wire connection table to include any out-of-date drawing files.

## Format

Changes the format of the extracted data. The dialog box lists the format files to select from.

## Location code selection for from/to reporting

When you select to run a Wire From/To report, AutoCAD Electrical extracts component, terminal, location code, and wire connection information from the selected drawings. This dialog box allows you to make your report's "from" and "to" location selections. All the location codes AutoCAD Electrical found on the drawing set are listed on each side of this dialog box. Location "(?)" is also included in the list if AutoCAD Electrical found any component or stand-alone terminals that did not have an assigned location code.

 **Ribbon:** Reports tab ► Schematic panel ► Reports.

 **Toolbar:** Main Electrical 2

**Menu:** Projects ► Reports ► Schematic Reports

**Command entry:** AESCHEMATICREPORT

Select Wire From/To from the report list. Specify whether to process the project, active drawing, or selected wires.

Select location codes from the left and right-hand lists to build the report's from/to combinations shown in the middle of the dialog box. Click OK to display the report. AutoCAD Electrical quickly filters and formats the extracted data and presents it in the Report Generator dialog box. You can then save it

to a text report file, a comma-delimited file to import into a spreadsheet or database program, or insert it on to a drawing in table format.

<b>Location codes</b>	Displays the “from” (left-hand list) and “to” location codes (right-hand list) found on the drawings. Clicking a location code moves the selected code from these lists to the Report From/To list in the center of the dialog box.
<b>Report From/To</b>	Displays the combination of location codes you selected from the Location Code lists. This is used to generate the Wire From/To report.
<b>Buttons</b>	<ul style="list-style-type: none"><li>■ All &gt;&gt; or All &lt;&lt;: Adds or removes all the location codes from the Report From/To list depending on which side of the dialog box the button is located.</li><li>■ &lt;&lt; or &gt; : Removes the selected location code from the Report From/To list.</li></ul>
<b>Multiple Combinations</b>	Displays the Select Multiple From/To Location Combinations for Report dialog box. Each location code in the “From” side is linked to each location code in the “To” side of the report. For example, if you select MACHINE (from) and FLOOR (to) in addition to MCAB5 (from) and JBOX1 (to) the following combinations are created: MACHINE -> FLOOR MACHINE -> JBOX1 MCAB5 -> FLOOR MCAB5 -> JBOX1 Each of the combinations is processed and combined into a single report. Adjust the list as needed (for example, you can select to remove highlighted combinations or keep only those combinations you highlight in the list) and click OK.
<b>Include reverse sequences</b>	Includes reversed wire connections in the report. If unselected, some Wire From/To combinations may be excluded due to wire sequencing.

# Panel Reports

## Generate panel reports

AutoCAD Electrical has multiple panel reports that you can run.

### Bill of Material report

This report parallels the Schematic BOM report, but deals with panel component and terminal footprint symbols and nameplates. Optionally, it can include schematic items that are not referenced on the panel layouts (for example, field devices). You can customize the scope of the report by filtering on certain location values (for example, report for CAB1 items only), process only a subset of drawings, or include/exclude certain categories of items. The report displays and tallies like items (for example, same part number) together. Those with extra subassembly items are shown with a SUB multiplier value.

### Component report

This report lists every occurrence of a smart panel component footprint found on the current drawing or in the project drawing set. You can customize the scope of the report by filtering on certain location values (for example, report for CAB1 items only), process only a subset of drawings, or include/exclude certain categories of items. Each extracted panel component is listed as its own line item. If it has a part number that results in subassembly part numbers, or has been individually annotated with multi-BOM part numbers, each additional part number is a line item right below the main line item.

---

**NOTE** This report will not include panel terminals unless you check that option.

---

### Nameplate report

This report is similar to the panel component report, but filters out all but nameplate symbols.

### Wire Connection report

Wire connection reports, extracted from the schematic wiring diagrams, can be formatted and inserted next to panel footprint symbols as simple wiring tables. AutoCAD Electrical extracts and formats a small report of wire connection information for the selected components, referencing the wire extract file. If your footprint symbols carry the AutoCAD Electrical X?TERMxx

attributes, AutoCAD Electrical reports their XYZ wire connection location. The location is offset by the value defined in Panel Configuration dialog box.

### **Component Exception report**

This report provides error checking between the schematics and panel layout drawings. AutoCAD Electrical looks at the selected components, both schematic and panel, looking for a match in the project. For each schematic component selected, it tries to find a matching panel component based on tag, location, and installation information. If a match is found, it compares catalog and description information, looking for any discrepancies. AutoCAD Electrical then looks at each selected panel component looking for a matching schematic component in the same way.

### **Terminal Exception report**

This report provides error checking between the schematic terminals and panel layout terminals. AutoCAD Electrical looks at the selected terminals, both schematic and panel, looking for a match in the project. For each schematic terminal selected, it tries to find a matching panel terminal. If a match is found, it compares catalog information, looking for any discrepancies. AutoCAD Electrical then looks at each selected panel terminal looking for a matching schematic terminal in the same way.

### **Wire Annotation Exception report**

This report lists which physical component symbol does not have a From and a To for wire annotation information. For wire annotation, the panel component symbols contain wiring information as either attributed or Mtext data. This is used as a troubleshooting mechanism to aid in the assignment of wiring annotation. End1 is the end of the wire that contains the annotation and End2 is the end of the wire that was annotated on End1, but is not found in the range of drawings selected.

### **Missing Level/Sequencing Assignments report**

This report lists which component symbols do not have leveling and sequencing information already assigned to them. This is used as a troubleshooting mechanism to aid in the assignment of leveling and sequencing information to provide better wire routing capabilities.

### **Generate a panel report**

Generates panel reports, such as Bills of Material, Component lists, and Nameplates.



Select which drawings to process. The report displays options to:

- Change included fields.
- Add or modify data.
- Print.
- Save to a file.
- Put on the drawings as table objects.



- 1 Click Reports tab ► Panel panel ► Reports.
- 2 Select which panel report to generate from the report list.
- 3 Select to process the project, active drawing, or selected components.
- 4 Select installation or location codes to extract (if applicable).
- 5 Specify to extract any installation or location codes (if applicable).
- 6 Indicate whether to update the project database with out-of-date drawings.
- 7 Click OK.
- 8 In the Report Generator Window, sort, format, or edit the data before sending the information to the printer, file, or the active drawing file.
  - **Edit Mode:** Modifies the report before you insert it in your drawing. You can move data up or down in the report, add lines from a catalog, and delete lines.
  - **Put on Drawing:** Opens the Table Generation Setup dialog box for specifying how to display your report as a table on your drawing.
  - **Save to File:** Saves the report to a file. Select the type of output file from the Save Report to File dialog box. You can define multiple file outputs. Choose from: ASCII report, Comma Delimited, Excel spreadsheet, Access database, and XML format.
  - **User Post:** Switches specific functions against the data in the report. When you select a switch, the LISP routine runs a function against the data and returns to the Report Generator Window.
  - **Change Report Format:** Changes which data fields are reported and the order in which they appear. You can change the justification of

any column and the column label. The Description field can be multi-lined. If you include the Description field in your report, you choose which lines make up this field. Switch on and off the specific fields to define the Description.

- 9 Once all modifications have been made to the report, save the report, place the report on the drawing as a table, or print the report.

## Panel bill of materials

This report parallels the Schematic BOM report, but deals with panel component and terminal footprint symbols and nameplates. Optionally, it can include schematic items that are not referenced on the panel layouts (for example, field devices). You can customize the scope of the report by filtering on certain location values (for example, report for CAB1 items only), process only a subset of drawings, or include/exclude certain categories of items. The report displays and tallies like items (for example, same part number) together. Those with extra subassembly items are shown with a "SUB" multiplier value.

 **Ribbon:** Reports tab ► Panel panel ► Reports. 

 **Toolbar:** Panel Layout 

 **Menu:** Projects ► Reports ► Panel Reports

 **Command entry:** AEPANELREPORT

Select Bill of Material from the report list.

Specify whether to process the project or the active drawing.

### Include options

<b>Include Nameplates</b>	Specifies to include nameplate information in the report.
<b>Include Cable/Connectors</b>	Specifies to include connector information in the report.
<b>All the above</b>	Specifies to cable, connector, and nameplate information in the report.

<b>List terminal numbers</b>	Lists each individual Tag-ID and terminal number combination if selected. If unselected (default), the terminals are combined on the same Tag-ID strip into a single entry with a quantity.
<b>Include Jumpers</b>	Specifies to include jumper information in the report.
<b>Full: include schematic components not referenced on panel layout</b>	Specifies to include all schematic component information not found on the panel layout in the report.

### **Display option**

<b>Normal Tallied Format</b>	Identical component or component/assemblies are tallied and reported as single line items (Ex: Red push-button operator 800EP-F4 with 800E-A3L latch and two 800E-3X10 N.O. contact blocks).
<b>Normal Tallied Format (Group by Installation/Location)</b>	Identical component or component/assemblies with the same installation/location codes are tallied and reported as single line items.
<b>Display in Tallied Purchase List Format</b>	Each part becomes its own line item (i.e. no longer any sub-assembly items) and each is tallied across all component types. For example, all 800E-3X10 N.O. contact blocks for all components are reported as a single line item.
<b>Display in By TAG Format</b>	All instances of a given component-ID or terminal tag are processed together and then reported as a single entry.

### **Installation Codes to Extract**

Extracts only the information for components with specific installation values. Indicate to process all components that carry part number values, components without an installation code, or only components marked with a location code that matches that entered in the edit box. Wild-cards are supported.

Once you pick Named Installation, type the installation code in the box or click List: Drawing or List: Project to select from a list of used installation codes. You can also create a report from multiple installation codes. AutoCAD

Electrical automatically creates a comma-delimited list for the named installation search.

### Location Codes to Extract

Extracts only the information for components with specific location values. Indicate to process all components that carry part number values, components without a location code, or only components marked with a location code that matches that entered in the edit box. For example, BOM report for components marked "OP STA 2." Wild cards are supported.

After you click Named Location, type the location code in the box, or click List: Drawing or List: Project to select from a list of used location codes. You can also create a report from multiple location codes. AutoCAD Electrical automatically creates a comma-delimited list for the named location search.

### Freshen Project Database







Specifies for AutoCAD Electrical to update the project database to include any out-of-date drawing files.

### Format

Changes the format of the extracted data. The dialog box lists the format files to select from.

## Panel component exception

This report provides error checking between the schematics and panel layout drawings. AutoCAD Electrical looks at the selected components, both schematic and panel, looking for a match in the project. For each schematic component selected, it tries to find a matching panel component based on tag, location, and installation information. If a match is found, it compares catalog and description information, looking for any discrepancies. AutoCAD Electrical then looks at each selected panel component looking for a matching schematic component in the same way.

-  **Ribbon:** Reports tab > Panel panel > Reports. 
-  **Toolbar:** Panel Layout 
-  **Menu:** Projects > Reports > Panel Reports
-  **Command entry:** AEPANELREPORT

Select Component Exception from the report list.

Specify whether to process the project, active drawing, or a selected component.

### **Conditions for Report**

Specifies which conditions the report checks for: whether the panel item is on the schematic, whether the schematic item is on a panel, if there are multiple instances of the terminal, and if there is a mismatch between schematic and panel terminals.

### **Installation Codes to Extract**

Extracts only the information for components with specific installation values. Indicate to process all components that carry part number values, components without an installation code, or only components marked with a location code that matches that entered in the edit box. Wild cards are supported.

Once you pick Named Installation, type the installation code in the box or click List: Drawing or List: Project to select from a list of used installation codes. You can also create a report from multiple installation codes. AutoCAD Electrical automatically creates a comma-delimited list for the named installation search.

### **Location Codes to Extract**

Extracts only the information for components with specific location values. Indicate to process all components that carry part number values, components without a location code, or only components marked with a location code that matches that entered in the edit box. For example, BOM report for components marked "OP STA 2." Wild cards are supported.

After you pick Named Location, type the location code in the box or click List: Drawing or List: Project to select from a list of used location codes. You can also create a report from multiple location codes. AutoCAD Electrical automatically creates a comma-delimited list for the named location search.

### **Redisplay Last Run**

Displays the previously extracted report.



### **Format**

Changes the format of the extracted data. The subdialog box lists the format files to select from.

## **Panel component**

This report lists every occurrence of a smart panel component footprint found on the current drawing or in the project drawing set. You can customize the scope of the report by filtering on certain location values (for example, report for CAB1 items only), process only a subset of drawings, or include/exclude certain categories of items. Note: this report will not include panel terminals unless you check that option. Each extracted panel component is listed as its own line item. If it has a part number that results in subassembly part numbers, or has been individually annotated with multi-BOM part numbers, each additional part number is a line item right below the main line item.

 **Ribbon:** Reports tab > Panel panel > Reports. 

 **Toolbar:** Panel Layout 

 **Menu:** Projects > Reports > Panel Reports

 **Command entry:** AEPANELREPORT

Select Component from the report list.

Specify whether to process the project or the active drawing.

### Options

Specifies to include nameplates or terminals in the report. You can also indicate to skip components with blank device TAG values or blank manufacturer or catalog values.

### Installation Codes to Extract

Extracts only the information for components with specific installation values. Indicate to process all components that carry part number values, components without an installation code, or only components marked with a location code that matches that entered in the edit box. Wild-cards are supported.

Once you pick Named Installation, type the installation code in the box or click List: Drawing or List: Project to select from a list of used installation codes. You can also create a report from multiple installation codes. AutoCAD Electrical automatically creates a comma-delimited list for the named installation search.

### Location Codes to Extract

Extracts only the information for components with specific location values. Indicate to process all components that carry part number values, components without a location code, or only components marked with a location code that matches that entered in the edit box. For example, BOM report for components marked "OP STA 2". Wild-cards are supported.

After you select Named Location, type the location code in the box or click List: Drawing or List: Project to select from a list of used location codes. You can also create a report from multiple location codes. AutoCAD Electrical automatically creates a comma-delimited list for the named location search.

### Freshen Project Database

Specifies for AutoCAD Electrical to update the project database to include any out-of-date drawing files.



### Format

Changes the format of the extracted data. The dialog box lists the format files to select from.

## Missing level/sequence assignments

This report lists which component symbols do not have leveling and sequencing information already assigned to them. This is used as a troubleshooting mechanism to aid in the assignment of leveling and sequencing information to provide better wire routing capabilities.

 **Ribbon:** Reports tab ► Panel panel ► Reports. 

 **Toolbar:** Panel Layout 

 **Menu:** Projects ► Reports ► Panel Reports

 **Command entry:** AEPANELREPORT

Select Missing Level/Sequencing Assignments from the report list.

In the Missing Level/Sequence Assignments dialog box, click Show to display temporary graphics around the insertion point of the panel layout symbols or click Report to run the report.

Specify whether to process the project or the active drawing.

### Installation Codes to Extract

Extracts only the information for components with specific installation values. Indicate to process all components that carry part number values, components without an installation code, or only components marked with a location code that matches that entered in the edit box. Wild-cards are supported.

Once you pick Named Installation, type the installation code in the box or click List: Drawing or List: Project to select from a list of used installation codes. You can also create a report from multiple installation codes. AutoCAD Electrical automatically creates a comma-delimited list for the named installation search.

### Location Codes to Extract

Extracts only the information for components with specific location values. Indicate to process all components that carry part number values, components without a location code, or only components marked with a location code that matches that entered in the edit box. For example, BOM report for components marked "OP STA 2". Wild-cards are supported.

Once you pick Named Location, type the location code in the box or click List: Drawing or List: Project to select from a list of used location codes. You can also create a report from multiple location codes. AutoCAD Electrical automatically creates a comma-delimited list for the named location search.

### Format

Changes the format of the extracted data. The subdialog box lists the format files to select from.

### Wire annotation exception

This report lists which physical component symbol does not have a From and a To for wire annotation information. For wire annotation, the panel component symbols contain wiring information as either attributed or Mtext data. This is used as a troubleshooting mechanism to aid in the assignment of wiring annotation. End1 is the end of the wire that contains the annotation and End2 is the end of the wire that was annotated on End1, but is not found in the range of drawings selected.

 **Ribbon:** Reports tab ► Panel panel ► Reports.







 **Toolbar:** Panel Layout

 **Menu:** Projects ► Reports ► Panel Reports

 **Command entry:** AEPANELREPORT

Select Wire Annotation Exception from the report list.

Specify whether to process the project or the active drawing.

### **Installation Codes to Extract**

Extracts only the information for components with specific installation values. Indicate to process all components that carry part number values, components without an installation code, or only components marked with a location code that matches that entered in the edit box. Wild-cards are supported.

Once you pick Named Installation, type the installation code in the box or click List: Drawing or List: Project to select from a list of used installation codes. You can also create a report from multiple installation codes. AutoCAD Electrical automatically creates a comma-delimited list for the named installation search.

### **Location Codes to Extract**

Extracts only the information for components with specific location values. Indicate to process all components that carry part number values, components without a location code, or only components marked with a location code that matches that entered in the edit box. For example, BOM report for components marked "OP STA 2". Wild-cards are supported.

Once you pick Named Location, type the location code in the box or click List: Drawing or List: Project to select from a list of used location codes. You can also create a report from multiple location codes. AutoCAD Electrical automatically creates a comma-delimited list for the named location search.

### **Format**

Changes the format of the extracted data. The subdialog box lists the format files to select from.

### **Panel nameplate**

This report is similar to the panel component report, but filters out all but nameplate symbols.

 **Ribbon:** Reports tab ► Panel panel ► Reports. 

 **Toolbar:** Panel Layout 

 **Menu:** Projects ► Reports ► Panel Reports

 **Command entry:** AEPANELREPORT

Select Nameplate from the report list.

Specify whether to process the project, active drawing, or a selected component.

### **Installation Codes to Extract**

Extracts only the information for components with specific installation values. Indicate to process all components that carry part number values, components without an installation code, or only components marked with a location code that matches that entered in the edit box. Wild-cards are supported.

Once you pick Named Installation, type the installation code in the box or click List: Drawing or List: Project to select from a list of used installation codes. You can also create a report from multiple installation codes. AutoCAD Electrical automatically creates a comma-delimited list for the named installation search.

### **Location Codes to Extract**

Extracts only the information for components with specific location values. Indicate to process all components that carry part number values, components without a location code, or only components marked with a location code that matches that entered in the edit box. For example, BOM report for components marked "OP STA 2." Wild cards are supported.

Once you pick Named Location, type the location code in the box or click List: Drawing or List: Project to select from a list of used location codes. You can also create a report from multiple location codes. AutoCAD Electrical automatically creates a comma-delimited list for the named location search.

### **Redisplay Last Run**

Displays the previously extracted report.



## Format

Changes the format of the extracted data. The dialog box lists the format files to select from.

## Panel terminal exception

This report provides error checking between the schematic terminals and panel layout terminals. AutoCAD Electrical looks at the selected terminals, both schematic and panel, looking for a match in the project. For each schematic terminal selected, it tries to find a matching panel terminal. If a match is found, it compares catalog information, looking for any discrepancies. AutoCAD Electrical then looks at each selected panel terminal looking for a matching schematic terminal in the same way.

 **Ribbon:** Reports tab > Panel panel > Reports. 

 **Toolbar:** Panel Layout 

 **Menu:** Projects > Reports > Panel Reports

 **Command entry:** AEPANELREPORT

Select Terminal Exception from the report list.

Specify whether to process the project, active drawing, or a selected component.

## Conditions for Report

Specifies which conditions the report checks for: whether the panel item is on the schematic, whether the schematic item is on a panel, if there are multiple instances of the terminal, and if there is a mismatch between schematic and panel terminals.

## Installation Codes to Extract

Extracts only the information for components with specific installation values. Indicate to process all components that carry part number values, components without an installation code, or only components marked with a location code that matches that entered in the edit box. Wild-cards are supported.

Once you pick Named Installation, type the installation code in the box or click List: Drawing or List: Project to select from a list of used installation codes. You can also create a report from multiple installation codes. AutoCAD

Electrical automatically creates a comma-delimited list for the named installation search.

### Location Codes to Extract

Extracts only the information for components with specific location values. Indicate to process all components that carry part number values, components without a location code, or only components marked with a location code that matches that entered in the edit box. For example, BOM report for components marked "OP STA 2." Wild cards are supported.

Once you pick Named Location, type the location code in the box or click List: Drawing or List: Project to select from a list of used location codes. You can also create a report from multiple location codes. AutoCAD Electrical automatically creates a comma-delimited list for the named location search.

### Redisplay Last Run

Displays the previously extracted report.



### Format

Changes the format of the extracted data. The dialog box lists the format files to select from.

## Panel wire connection

Wire connection reports, extracted from the schematic wiring diagrams, can be formatted and inserted next to panel footprint symbols as simple wiring tables. AutoCAD Electrical extracts and formats a small report of wire connection information for the selected components, referencing the wire extract file. If your footprint symbols carry the AutoCAD Electrical X?TERMxx attributes, AutoCAD Electrical reports their XYZ wire connection location. The location is offset by the value defined in Panel Configuration dialog box.

 **Ribbon:** Reports tab ► Panel panel ► Reports. 

 **Toolbar:** Panel Layout 

 **Menu:** Projects ► Reports ► Panel Reports

 **Command entry:** AEPANELREPORT

Select Wire Connection from the report list.

Specify whether to process the project, active drawing, or a selected component.

#### **Installation Codes to Extract**

Extracts only the information for components with specific installation values. Indicate to process all components that carry part number values, components without an installation code, or only components marked with a location code that matches that entered in the edit box. Wild-cards are supported.

After you pick Named Installation, type the installation code in the box or click List: Drawing or List: Project to select from a list of used installation codes. You can also create a report from multiple installation codes. AutoCAD Electrical automatically creates a comma-delimited list for the named installation search.

#### **Location Codes to Extract**

Extracts only the information for components with specific location values. Indicate to process all components that carry part number values, components without a location code, or only components marked with a location code that matches that entered in the edit box. For example, BOM report for components marked "OP STA 2." Wild cards are supported.

After you pick Named Location, type the location code in the box or click List: Drawing or List: Project to select from a list of used location codes. You can also create a report from multiple location codes. AutoCAD Electrical automatically creates a comma-delimited list for the named location search.

#### **Redisplay Last Run**

Displays the previously extracted report.

#### **Format**

Changes the format of the extracted data. The dialog box lists the format files to select from.

## **Overview of format files**

A Format File (.set file) can be used to pre-format a report for both manually-run reports and automatic reports. When running automatic reports, more options are used within the .set file, since user input is not required for each report (automatic reports are covered in next section). You can create as many format files as you want. If you are using updatable, intelligent tables, a format file is the third item that makes a report table unique. If you want

to be able to insert multiple updatable tables for the same report with the same scope you need to use different format files for each report. If you are not inserting updatable tables, or the report or scope is different, then you do not need to use different format files.

A format file defines which fields to include from the available fields, the field order, justification, and column label. This information from the format file is used for both manual and automatic reports. When running automatic reports, the format file can also contain information for saving the report to file(s) and/or putting the report on the drawing(s) as a report table. The Report Format File Setup dialog box allows you to create or modify your format files.

You can enter in X-Y coordinates for the first section or click Pick to select a location. If you are breaking your report table into sections and are allowing multiple table sections per drawing, you can define the distance from one table section to the next. The value entered here is the distance between the end of one table section and the start of the next. For example, if you want 2 inches between table sections horizontally, enter a 2 as the X-Distance value. A blank value is interpreted as zero.

---

**NOTE** Your format file can be saved using any file name but is given a ".set" file extension. The format files can be edited using any text file editor but it is not recommended since the syntax for the files is somewhat complicated. It is recommended that you use the Report Format File Setup dialog box to create or modify your format files. If you are going to use Automatic Reports to create output files click "Save Report to File".

---

You can select each file type available for the selected report and enter one file name per type. If multiple file types are selected, when the report is run using the Automatic Reports, each file is created from that report data.

## Define format files

Creates and maintains a report formatting file.

A format (.set) file pre-formats both automatic reports and reports you run manually. A format file defines:

- Fields to include from the available fields
- Field order and justification
- Column labels
- File output options
- Table output options

- 1 Click Reports tab ► Miscellaneous panel ► Report Format Setup.



---

**NOTE** You can also open this dialog box by clicking Format File Setup on the [Automatic Report Selection](#) on page 1497 dialog box.

---

- 2 Select which report to generate a format file for or open an existing format file.
- 3 Specify any report options (if applicable).
- 4 Select installation or location codes to extract (if applicable).
- 5 (Optional) Select to add special break values to the page header. Selecting a special break of Installation/Location, displays the values for these devices in the report section header.
- 6 Sort or format the data before saving the format file.

---

**TIP** If you are going to use the format file in automatic reports you should define either the Save Report to File options and/or Put on Drawing options since the reports are not displayed in the Report Generator dialog box.

---

- **Save Report to File:** Saves the report to a file. Select the type of output file from the Save Report to File dialog box. You can define multiple file outputs. Choose from: ASCII report, Comma Delimited, Excel spreadsheet, Access database, and XML format.
  - **Change Report Fields:** Changes which data fields are reported and the order in which they appear. You can change the justification of any column and the column label. The Description field can be multi-lined. If you include the Description field in your report, you choose which lines make up this field. Switch on and off the specific fields to define the Description.
  - **Put on Drawing:** Opens the [Table Generation Setup](#) on page 1318 dialog box for specifying how to display your report as a table on your drawing.
  - **Sort Fields:** Controls the sorting order of fields in the report.
- 7 Save the format file for later retrieval and usage when generating reports.

8 Click Done.

## Report format file setup - panel bill of material

 **Ribbon:** Reports tab ► Miscellaneous panel ► Report Format Setup.



 **Toolbar:** Schematic Reports

 **Menu:** Projects ► Reports ► Report Format File Setup

 **Command entry:** AEFORMATFILE

Select Bill of Material from the Panel report

### Include options

Specifies whether to include nameplates, cable/connectors, or both in the report. You can also indicate whether to include schematic components not referenced on the panel layout.

### Display option

- **Normal Tallied Format:** identical component or component/assemblies are tallied and reported as single line items (Ex: Red push-button operator 800EP-F4 with 800E-A3L latch and two 800E-3X10 N.O. contact blocks).
- **Normal Tallied Format (Group by Installation/Location):** identical component or component/assemblies with the same installation/location codes are tallied and reported as single line items.
- **Display in Tallied Purchase List Format:** each part becomes its own line item (i.e. no longer any sub-assembly items) and each is tallied across all component types. For example, all 800E-3X10 N.O. contact blocks for all components are reported as a single line item.
- **Display in By TAG Format:** all instances of a given component-ID or terminal tag are processed together and then reported as a single entry.

### Installation Codes to Extract

Extracts only the information for components with specific installation values. Indicate to process all components, components without an installation code,



or only components marked with an installation code that matches that entered in the edit box. Wild-cards are supported.

Once you pick the Named Installation button, you can simply type the installation code in the box or click the List: Drawing or List: Project button to select from a list of used installation codes.

### Location Codes to Extract

Extracts only the information for components with specific location values. Indicate to process all components, components without a location code, or only components marked with a location code that matches that entered in the edit box. Wild-cards are supported.

Once you pick the Named Location button, you can simply type the location code in the box or click the List: Drawing or List: Project button to select from a list of used location codes.

### Report options

- **Save Report to File:** Saves the report to a file. Select the type of output file from the Save Report to File dialog box. You can define multiple file outputs using this dialog box. Choose from: ASCII report (.rep), Comma Delimited (.csv), Excel spreadsheet (.xls), Access database (.mdb), and XML (.xml) format.

The First Section Only button indicates to only show the selected option (such as title line or time and date) on the first section of the report, if multiple sections are used. If not selected, the selected options will be shown on all report sections.

- **Change Report Fields:** Changes what data fields are reported and the order in which they appear. You can also change the justification of any column and even the column label. The Description field is handled a little differently than the other fields. This field can be a multi-line field which is actually made up of multiple fields. If you include the Description field in your report, you choose which lines make up this field. Just toggle on and off the specific fields to define the Description.
- **Put on Drawing:** Opens the Table Generation Setup dialog box for specifying how to display your report as a table on your drawing.
- **Sort Fields:** Controls the sorting order of the fields in the report.

---

**NOTE** The options are saved in the format file after you click OK on the subdialog boxes. If you are working in an unnamed format file, you have to save the data after you select Done in order to keep the changes you have made.

---

## Breaks

- **Special breaks:** Specifies the value that controls the section break. The drop-down list displays the report-specific content to apply to the special break.
- **Add Special break values to header:** Adds the special break value to the page header. For example, if you select a special break of Installation/Location, the values provided for these devices in the panel are displayed in the report section header.

## Format File

Format files define specific criteria applied to the report before generating the report to screen, printer, file, or automatic generation. The format files are saved to the 'Documents and Settings\{user name}' subdirectory or 'Users\{user name}' on a Windows Vista or Windows 7 installation.

- **Open Format File:** Selects format files to edit. The Report Format Settings File Selection dialog box opens and displays a list of format files (.set) in the user subdirectory. Select a file to edit from the list and click OK.
- **Save Format File:** Saves a format file on the hard disk for later retrieval and usage when generating reports.
- **Save As Format File:** Saves a format file that you opened and modified with a different name.

## Report format file setup - panel component exception

 **Ribbon:** Reports tab ► Miscellaneous panel ► Report Format Setup.



 **Toolbar:** Schematic Reports



 **Menu:** Projects ► Reports ► Report Format File Setup

 **Command entry:** AEFORMATFILE

Select Component Exception from the Panel report list.

### Conditions for Report

Specifies which conditions the report checks for: the panel item is not on the schematic, the schematic item is not on a panel, multiple instances of the component, and if there is a mismatch between schematic components and panel components.

### Installation Codes to Extract

Extracts only the information for components with specific installation values. Indicate to process all components, components without an installation code, or only components marked with an installation code that matches that entered in the edit box. Wild-cards are supported.

Once you pick the Named Installation button, you can simply type the installation code in the box or click the List: Drawing or List: Project button to select from a list of used installation codes.

### Location Codes to Extract

Extracts only the information for components with specific location values. Indicate to process all components, components without a location code, or only components marked with a location code that matches that entered in the edit box. Wild-cards are supported.

Once you pick the Named Location button, you can simply type the location code in the box or click the List: Drawing or List: Project button to select from a list of used location codes.

### Report options

- **Save Report to File:** Saves the report to a file. Select the type of output file from the Save Report to File dialog box. You can define multiple file outputs using this dialog box. Choose from: ASCII report (.rep), Comma Delimited (.csv), Excel spreadsheet (.xls), Access database (.mdb), and XML (.xml) format.  
The First Section Only button indicates to only show the selected option (such as title line or time and date) on the first section of the report, if multiple sections are used. If not selected, the selected options will be shown on all report sections.
- **Change Report Fields:** Changes what data fields are reported and the order in which they appear. You can also change the justification of any column and even the column label. If you include the Description field in your report, you choose which lines make up this field. Just toggle on and off the specific fields to define the Description.

- **Put on Drawing:** Opens the Table Generation Setup dialog box for specifying how to display your report as a table on your drawing.
- **Sort Fields:** Controls the sorting order of the fields in the report.

---

**NOTE** The options are saved in the format file after you click OK on the subdialog boxes. If you are working in an unnamed format file, you have to save the data after you select Done in order to keep the changes you have made.

---

### Breaks

- **Special breaks:** Specifies the value that controls the section break. The drop-down list displays the report-specific content to apply to the special break.
- **Add Special break values to header:** Adds the special break value to the page header. For example, if you select a special break of Installation/Location, the values provided for these devices in the panel are displayed in the report section header.

### Format File

Format files define specific criteria applied to the report before generating the report to screen, printer, file, or automatic generation. The format files are saved to the 'Documents and Settings\{user name}' subdirectory or 'Users\{user name}' on a Windows Vista or Windows 7 installation.

- **Open Format File:** Selects format files to edit. The Report Format Settings File Selection dialog box opens and displays a list of format files (.set) in the user subdirectory. Select a file to edit from the list and click OK.
- **Save Format File:** Saves a format file on the hard disk for later retrieval and usage when generating reports.
- **Save As Format File:** Saves a format file that you opened and modified with a different name.

## Report format file setup - panel component

 **Ribbon:** Reports tab ► Miscellaneous panel ► Report Format Setup.





 **Toolbar:** Schematic Reports

 **Menu:** Projects ► Reports ► Report Format File Setup

 **Command entry:** AEFORMATFILE

Select Component from the Panel report list.

### Options

Specifies to include nameplates, cables, connectors, terminals, or all of them in the report. You can also indicate to skip components with blank device TAG values or blank manufacturer or catalog values.

### Installation Codes to Extract

Extracts only the information for components with specific installation values. Indicate to process all components, components without an installation code, or only components marked with an installation code that matches that entered in the edit box. Wild-cards are supported.

Once you pick the Named Installation button, you can simply type the installation code in the box or click the List: Drawing or List: Project button to select from a list of used installation codes.

### Location Codes to Extract

Extracts only the information for components with specific location values. Indicate to process all components, components without a location code, or only components marked with a location code that matches that entered in the edit box. Wild-cards are supported.

Once you pick the Named Location button, you can simply type the location code in the box or click the List: Drawing or List: Project button to select from a list of used location codes.

### Report options

- **Save Report to File:** Saves the report to a file. Select the type of output file from the Save Report to File dialog box. You can define multiple file outputs using this dialog box. Choose from: ASCII report (.rep), Comma Delimited (.csv), Excel spreadsheet (.xls), Access database (.mdb), and XML (.xml) format.

The First Section Only button indicates to only show the selected option (such as title line or time and date) on the first section of the report, if

multiple sections are used. If not selected, the selected options will be shown on all report sections.

- **Change Report Fields:** Changes what data fields are reported and the order in which they appear. You can also change the justification of any column and even the column label. If you include the Description field in your report, you choose which lines make up this field. Just toggle on and off the specific fields to define the Description.
- **Put on Drawing:** Opens the Table Generation Setup dialog box for specifying how to display your report as a table on your drawing.
- **Sort Fields:** Controls the sorting order of the fields in the report.

---

**NOTE** The options are saved in the format file after you click OK on the subdialog boxes. If you are working in an unnamed format file, you have to save the data after you select Done in order to keep the changes you have made.

---

### Breaks

- **Special breaks:** Specifies the value that controls the section break. The drop-down list displays the report-specific content to apply to the special break.
- **Add Special break values to header:** Adds the special break value to the page header. For example, if you select a special break of Installation/Location, the values provided for these devices in the panel are displayed in the report section header.

### Format File

Format files define specific criteria applied to the report before generating the report to screen, printer, file, or automatic generation. The format files are saved to the 'Documents and Settings\{user name}' subdirectory or 'Users\{user name}' on a Windows Vista or Windows 7 installation.

- **Open Format File:** Selects format files to edit. The Report Format Settings File Selection dialog box opens and displays a list of format files (.set) in the user subdirectory. Select a file to edit from the list and click OK.
- **Save Format File:** Saves a format file on the hard disk for later retrieval and usage when generating reports.
- **Save As Format File:** Saves a format file that you opened and modified with a different name.

## Report format file setup - missing level/sequence assignments

 **Ribbon:** Reports tab ► Miscellaneous panel ► Report Format Setup.



 **Toolbar:** Schematic Reports



 **Menu:** Projects ► Reports ► Report Format File Setup

 **Command entry:** AEFORMATFILE

Select Missing Level/Sequence Assignments from the Panel report list.

### Installation Codes to Extract

Extracts only the information for components with specific installation values. Indicate to process all components, components without an installation code, or only components marked with an installation code that matches that entered in the edit box. Wild-cards are supported.

After you pick the Named Installation button, you can type the installation code in the box or click the List: Drawing or List: Project button to select from a list of used installation codes.

### Location Codes to Extract

Extracts only the information for components with specific location values. Indicate to process all components, components without a location code, or only components marked with a location code that matches that entered in the edit box. Wild-cards are supported.

After you pick the Named Location button, you can type the location code in the box or click the List: Drawing or List: Project button to select from a list of used location codes.

### Report options

- **Save Report to File:** Saves the report to a file. Select the type of output file from the Save Report to File dialog box. You can define multiple file outputs. Choose from: ASCII report (.rep), Comma Delimited (.csv), Excel spreadsheet (.xls), Access database (.mdb), and XML (.xml) format. The First Section Only button indicates to only show the selected option (such as title line or time and date) on the first section of the report, if

multiple sections are used. If not selected, the selected options are shown on all report sections.

- **Change Report Fields:** Changes what data fields are reported and the order in which they appear. You can also change the justification of any column and even the column label. The Description field is handled a little differently than the other fields. This field can be a multi-line field which is actually made up of multiple fields. If you include the Description field in your report, choose which lines make up this field. Switch on and off the specific fields to define the Description.
- **Put on Drawing:** Opens the Table Generation Setup dialog box for specifying how to display your report as a table on your drawing.
- **Sort Fields:** Controls the sorting order of the fields in the report.

---

**NOTE** The options are saved in the format file after you click OK in the dialog boxes. If you are working in an unnamed format file, you must save the data after you select Done to keep the changes.

---

### Format File

Format files define specific criteria applied to the report before generating the report to screen, printer, file, or automatic generation. The format files are saved to the 'Documents and Settings\{user name}' subdirectory or 'Users\{user name}' on a Windows Vista or Windows 7 installation.

- **Open Format File:** Selects format files to edit. The Report Format Settings File Selection dialog box opens and displays a list of format files (.set) in the user subdirectory. Select a file to edit from the list and click OK.
- **Save Format File:** Saves a format file on the hard disk for later retrieval and usage when generating reports.
- **Save As Format File:** Saves a format file that you opened and modified with a different name.

### Report format file setup - wire annotation exception

 **Ribbon:** Reports tab ► Miscellaneous panel ► Report Format Setup.







 **Toolbar:** Schematic Reports

 **Menu:** Projects ► Reports ► Report Format File Setup

 **Command entry:** AEFORMATFILE

Select Wire Annotation Exception from the Panel report list.

### Installation Codes to Extract

Extracts only the information for components with specific installation values. Indicate to process all components, components without an installation code, or only components marked with an installation code that matches that entered in the edit box. Wild cards are supported.

After you click the Named Installation button, you can type the installation code in the box, or click the List: Drawing or List: Project button to select from a list of used installation codes.

### Location Codes to Extract

Extracts only the information for components with specific location values. Indicate to process all components, components without a location code, or only components marked with a location code that matches that entered in the edit box. Wild cards are supported.

After you click the Named Location button, you can type the location code in the box, or click the List: Drawing or List: Project button to select from a list of used location codes.

### Report options

- **Save Report to File:** Saves the report to a file. Select the type of output file from the Save Report to File dialog box. You can define multiple file outputs using this dialog box. Choose from: ASCII report (.rep), Comma Delimited (.csv), Excel spreadsheet (.xls), Access database (.mdb), and XML (.xml) format.

The First Section Only button indicates to only show the selected option (such as title line or time and date) on the first section of the report, if multiple sections are used. If not selected, the selected options are shown on all report sections.

- **Change Report Fields:** Changes what data fields are reported and the order in which they appear. You can also change the justification of any column and even the column label. The Description field is handled a little differently than the other fields. This field can be a multi-line field which

is actually made up of multiple fields. If you include the Description field in your report, you choose which lines make up this field. Switch on and off the specific fields to define the Description.

- **Put on Drawing:** Opens the Table Generation Setup dialog box for specifying how to display your report as a table on your drawing.
- **Sort Fields:** Controls the sorting order of the fields in the report.

---

**NOTE** The options are saved in the format file after you click OK in the dialog boxes. If you are working in an unnamed format file, you must save the data after you select Done to keep the changes.

---

### Format File

Format files define specific criteria applied to the report before generating the report to screen, printer, file, or automatic generation. The format files are saved to the "Documents and Settings\{user name}" subdirectory or 'Users\{user name}' on a Windows Vista or Windows 7 installation.

- **Open Format File:** Selects format files to edit. The Report Format Settings File Selection dialog box opens and displays a list of format files (.set) in the user subdirectory. Select a file to edit from the list and click OK.
- **Save Format File:** Saves a format file on the hard disk for later retrieval and usage when generating reports.
- **Save As Format File:** Saves a format file that you opened and modified with a different name.

## Report format file setup - panel nameplate

 **Ribbon:** Reports tab ► Miscellaneous panel ► Report Format Setup.



 **Toolbar:** Schematic Reports



 **Menu:** Projects ► Reports ► Report Format File Setup

 **Command entry:** AEFORMATFILE

Select Nameplate from the Panel report list.

### **Installation Codes to Extract**

Extracts only the information for components with specific installation values. Indicate to process all components, components without an installation code, or only components marked with an installation code that matches that entered in the edit box. Wild-cards are supported.

Once you pick the Named Installation button, you can simply type the installation code in the box or click the List: Drawing or List: Project button to select from a list of used installation codes.

### **Location Codes to Extract**

Extracts only the information for components with specific location values. Indicate to process all components, components without a location code, or only components marked with a location code that matches that entered in the edit box. Wild-cards are supported.

Once you pick the Named Location button, you can simply type the location code in the box or click the List: Drawing or List: Project button to select from a list of used location codes.

### **Report options**

- **Save Report to File:** Saves the report to a file. Select the type of output file from the Save Report to File dialog box. You can define multiple file outputs using this dialog box. Choose from: ASCII report (.rep), Comma Delimited (.csv), Excel spreadsheet (.xls), Access database (.mdb), and XML (.xml) format.  
The First Section Only button indicates to only show the selected option (such as title line or time and date) on the first section of the report, if multiple sections are used. If not selected, the selected options will be shown on all report sections.
- **Change Report Fields:** Changes what data fields are reported and the order in which they appear. You can also change the justification of any column and even the column label. If you include the Description field in your report, you choose which lines make up this field. Just toggle on and off the specific fields to define the Description.
- **Put on Drawing:** Opens the Table Generation Setup dialog box for specifying how to display your report as a table on your drawing.
- **Sort Fields:** Controls the sorting order of the fields in the report.

---

**NOTE** The options are saved in the format file after you click OK on the subdialog boxes. If you are working in an unnamed format file, you have to save the data after you select Done in order to keep the changes you have made.

---

### Breaks

- **Special breaks:** Specifies the value that controls the section break. The drop-down list displays the report-specific content to apply to the special break.
- **Add Special break values to header:** Adds the special break value to the page header. For example, if you select a special break of Installation/Location, the values provided for these devices in the panel are displayed in the report section header.

### Format File

Format files define specific criteria applied to the report before generating the report to screen, printer, file, or automatic generation. The format files are saved to the 'Documents and Settings\{user name}' subdirectory or 'Users\{user name}' on a Windows Vista or Windows 7 installation.

- **Open Format File:** Selects format files to edit. The Report Format Settings File Selection dialog box opens and displays a list of format files (.set) in the user subdirectory. Select a file to edit from the list and click OK.
- **Save Format File:** Saves a format file on the hard disk for later retrieval and usage when generating reports.
- **Save As Format File:** Saves a format file that you opened and modified with a different name.

### Report format file setup - panel terminal exception

 **Ribbon:** Reports tab ► Miscellaneous panel ► Report Format Setup.



 **Toolbar:** Schematic Reports



 **Menu:** Projects ► Reports ► Report Format File Setup

 **Command entry:** AEFORMATFILE

Select Terminal Exception from the Panel report list.

### Conditions for Report

Specifies which conditions the report checks for: the panel item is not on the schematic, the schematic item is not on a panel, multiple instances of the terminal, and if there is a mismatch between schematic terminals and panel terminals.

### Installation Codes to Extract

Extracts only the information for components with specific installation values. Indicate to process all components, components without an installation code, or only components marked with an installation code that matches that entered in the edit box. Wild-cards are supported.

Once you pick the Named Installation button, you can simply type the installation code in the box or click the List: Drawing or List: Project button to select from a list of used installation codes.

### Location Codes to Extract

Extracts only the information for components with specific location values. Indicate to process all components, components without a location code, or only components marked with a location code that matches that entered in the edit box. Wild-cards are supported.

Once you pick the Named Location button, you can simply type the location code in the box or click the List: Drawing or List: Project button to select from a list of used location codes.

### Report options

- **Save Report to File:** Saves the report to a file. Select the type of output file from the Save Report to File dialog box. You can define multiple file outputs using this dialog box. Choose from: ASCII report (.rep), Comma Delimited (.csv), Excel spreadsheet (.xls), Access database (.mdb), and XML (.xml) format.

The First Section Only button indicates to only show the selected option (such as title line or time and date) on the first section of the report, if multiple sections are used. If not selected, the selected options will be shown on all report sections.

- **Change Report Fields:** Changes what data fields are reported and the order in which they appear. You can also change the justification of any column and even the column label. If you include the Description field in your

report, you choose which lines make up this field. Just toggle on and off the specific fields to define the Description.

- **Put on Drawing:** Opens the Table Generation Setup dialog box for specifying how to display your report as a table on your drawing.
- **Sort Fields:** Controls the sorting order of the fields in the report.

---

**NOTE** The options are saved in the format file after you click OK on the subdialog boxes. If you are working in an unnamed format file, you have to save the data after you select Done in order to keep the changes you have made.

---

### Breaks

- **Special breaks:** Specifies the value that controls the section break. The drop-down list displays the report-specific content to apply to the special break.
- **Add Special break values to header:** Adds the special break value to the page header. For example, if you select a special break of Installation/Location, the values provided for these devices in the panel are displayed in the report section header.

### Format File

Format files define specific criteria applied to the report before generating the report to screen, printer, file, or automatic generation. The format files are saved to the 'Documents and Settings\{user name}' subdirectory or 'Users\{user name}' on a Windows Vista or Windows 7 installation.

- **Open Format File:** Selects format files to edit. The Report Format Settings File Selection dialog box opens and displays a list of format files (.set) in the user subdirectory. Select a file to edit from the list and click OK.
- **Save Format File:** Saves a format file on the hard disk for later retrieval and usage when generating reports.
- **Save As Format File:** Saves a format file that you opened and modified with a different name.

## Report format file setup - panel wire connection

 **Ribbon:** Reports tab ► Miscellaneous panel ► Report Format Setup.



 **Toolbar:** Schematic Reports



 **Menu:** Projects ► Reports ► Report Format File Setup

 **Command entry:** AEFORMATFILE

Select Wire Connection from the Panel report list.

### Installation Codes to Extract

Extracts only the information for components with specific installation values. Indicate to process all components, components without an installation code, or only components marked with an installation code that matches that entered in the edit box. Wild-cards are supported.

Once you pick the Named Installation button, you can simply type the installation code in the box or click the List: Drawing or List: Project button to select from a list of used installation codes.

### Location Codes to Extract

Extracts only the information for components with specific location values. Indicate to process all components, components without a location code, or only components marked with a location code that matches that entered in the edit box. Wild-cards are supported.

Once you pick the Named Location button, you can simply type the location code in the box or click the List: Drawing or List: Project button to select from a list of used location codes.

### Report options

■ **Save Report to File:** Saves the report to a file. Select the type of output file from the Save Report to File dialog box. You can define multiple file outputs using this dialog box. Choose from: ASCII report (.rep), Comma Delimited (.csv), Excel spreadsheet (.xls), Access database (.mdb), and XML (.xml) format.

The First Section Only button indicates to only show the selected option (such as title line or time and date) on the first section of the report, if

multiple sections are used. If not selected, the selected options will be shown on all report sections.

- **Change Report Fields:** Changes what data fields are reported and the order in which they appear. You can also change the justification of any column and even the column label. If you include the Description field in your report, you choose which lines make up this field. Just toggle on and off the specific fields to define the Description.
- **Put on Drawing:** Opens the Table Generation Setup dialog box for specifying how to display your report as a table on your drawing.
- **Sort Fields:** Controls the sorting order of the fields in the report.

---

**NOTE** The options are saved in the format file after you click OK on the subdialog boxes. If you are working in an unnamed format file, you have to save the data after you select Done in order to keep the changes you have made.

---

### Breaks

- **Special breaks:** Specifies the value that controls the section break. The drop-down list displays the report-specific content to apply to the special break.
- **Add Special break values to header:** Adds the special break value to the page header. For example, if you select a special break of Installation/Location, the values provided for these devices in the panel are displayed in the report section header.

### Format File

Format files define specific criteria applied to the report before generating the report to screen, printer, file, or automatic generation. The format files are saved to the 'Documents and Settings\{user name}' subdirectory or 'Users\{user name}' on a Windows Vista or Windows 7 installation.

- **Open Format File:** Selects format files to edit. The Report Format Settings File Selection dialog box opens and displays a list of format files (.set) in the user subdirectory. Select a file to edit from the list and click OK.
- **Save Format File:** Saves a format file on the hard disk for later retrieval and usage when generating reports.
- **Save As Format File:** Saves a format file that you opened and modified with a different name.



## Report format file setup - schematic bill of material

 **Ribbon:** Reports tab ► Miscellaneous panel ► Report Format Setup.



 **Toolbar:** Schematic Reports



 **Menu:** Projects ► Reports ► Report Format File Setup

 **Command entry:** AEFORMATFILE

Select Bill of Material from the Schematic report list.

### Category

By default, the report lists schematic components. Select a different Category to run the report for one-line, one-line bus-tap, hydraulic, pneumatic, P&ID, or user-defined components. These components are each identified by a unique [WDTYPE attribute](#) on page 325 value.

### Include options

Specifies to include cables, connectors, or both in the report.

### Display option

- **Normal Tallied Format:** identical component or component/assemblies are tallied and reported as single line items (for example, Red push-button operator 800EP-F4 with 800E-A3L latch and two 800E-3X10 N.O. contact blocks).
- **Normal Tallied Format (Group by Installation/Location):** identical component or component/assemblies with the same installation/location codes are tallied and reported as single line items.
- **Display in Tallied Purchase List Format:** each part becomes its own line item (for example, no longer any subassembly items) and each is tallied across all component types. For example, all 800E-3X10 N.O. contact blocks for all components are reported as a single line item.
- **Display in By TAG Format:** all instances of a given component-ID or terminal tag are processed together and reported as a single entry.

### Installation Codes to Extract

Extracts only the information for components with specific installation values. Indicate to process all components, components without an installation code, or only components marked with an installation code that matches that entered in the edit box. Wild-cards are supported.

Once you click Named Installation, you can type the installation code in the box or click List: Drawing or List: Project to select from a list of used installation codes.

### Location Codes to Extract

Extracts only the information for components with specific location values. Indicate to process all components, components without a location code, or only components marked with a location code that matches that entered in the edit box. Wild-cards are supported.

Once you click Named Location, you can type the location code in the box or click List: Drawing or List: Project to select from a list of used location codes.

### Report options

- **Save Report to File:** Saves the report to a file. Select the type of output file from the Save Report to File dialog box. You can define multiple file outputs. Choose from: ASCII report (.rep), Comma Delimited (.csv), Excel spreadsheet (.xls), Access database (.mdb), and XML (.xml) format. First Section Only shows only the selected option (such as title line or time and date) on the first section of the report if multiple sections are used. If not checked, the selected options are shown on all report sections.
- **Change Report Fields:** Changes what data fields are reported and the order in which they appear. You can change the justification of any column and the column label. The Description field can be multi-lined. If you include the Description field in your report, you choose which lines make up this field. Toggle on and off the specific fields to define the Description.
- **Put on Drawing:** Opens the Table Generation Setup dialog box for specifying how to display your report as a table on your drawing.
- **Sort Fields:** Controls the sorting order of the fields in the report.

---

**NOTE** The options are saved in the format file after you click OK on the dialog boxes. If you are working in an unnamed format file, you must save the data after you click Done to keep the changes you made.

---

## Breaks

- **Special breaks:** Specifies the value that controls the section break. The list displays the report-specific content to apply to the special break.
- **Add Special break values to header:** Adds the special break value to the page header. For example, if you select a special break of Installation/Location, the values provided for these devices in the schematic are displayed in the report section header.

## Format File

Format files define specific criteria applied to the report before generating the report to screen, printer, file, or automatic generation. The format files are saved to the 'Documents and Settings\{user name}' subdirectory or 'Users\{user name}' on a Windows Vista or Windows 7 installation.

- **Open Format File:** Selects format files to edit. The Report Format Settings File Selection dialog box opens and displays a list of format files (.set) in the user subdirectory. Select a file to edit from the list and click OK.
- **Save Format File:** Saves a format file on the hard drive for later retrieval and usage when generating reports.
- **Save As Format File:** Saves a format file that you opened and modified with a different name.

## Report format file setup - schematic cable from/to

 **Ribbon:** Reports tab ► Miscellaneous panel ► Report Format Setup.



 **Toolbar:** Schematic Reports



 **Menu:** Projects ► Reports ► Report Format File Setup

 **Command entry:** AEFORMATFILE

Select Cable From/To from the Schematic report list

## Category

By default, the report lists schematic components. Select a different Category to run the report for one-line, one-line bus-tap, hydraulic, pneumatic, P&ID,

or user-defined components. These components are each identified by a unique [WDTYPE attribute](#) on page 325 value.

### Report options

- **Save Report to File:** Saves the report to a file. Select the type of output file from the Save Report to File dialog box. You can define multiple file outputs using this dialog box. Choose from: ASCII report (.rep), Comma Delimited (.csv), Excel spreadsheet (.xls), Access database (.mdb), and XML (.xml) format.  
The First Section Only button indicates to only show the selected option (such as title line or time and date) on the first section of the report, if multiple sections are used. If not selected, the selected options will be shown on all report sections.
- **Change Report Fields:** Changes what data fields are reported and the order in which they appear. You can also change the justification of any column and even the column label. If you include the Description field in your report, you choose which lines make up this field. Just toggle on and off the specific fields to define the Description.
- **Put on Drawing:** Opens the Table Generation Setup dialog box for specifying how to display your report as a table on your drawing.
- **Sort Fields:** Controls the sorting order of the fields in the report.

---

**NOTE** The options are saved in the format file after you click OK on the subdialog boxes. If you are working in an unnamed format file, you have to save the data after you select Done in order to keep the changes you have made.

---

### Breaks

- **Special breaks:** Specifies the value that controls the section break. The drop-down list displays the report-specific content to apply to the special break.
- **Add Special break values to header:** Adds the special break value to the page header. For example, if you select a special break of Installation/Location, the values provided for these devices in the schematic are displayed in the report section header.

### Format File

Format files define specific criteria applied to the report before generating the report to screen, printer, file, or automatic generation. The format files are

saved to the 'Documents and Settings\{user name}' subdirectory or 'Users\{user name}' on a Windows Vista or Windows 7 installation.

- **Open Format File:** Selects format files to edit. The Report Format Settings File Selection dialog box opens and displays a list of format files (.set) in the user subdirectory. Select a file to edit from the list and click OK.
- **Save Format File:** Saves a format file on the hard disk for later retrieval and usage when generating reports.
- **Save As Format File:** Saves a format file that you opened and modified with a different name.

## Report format file setup - schematic cable summary

 **Ribbon:** Reports tab ► Miscellaneous panel ► Report Format Setup.



 **Toolbar:** Schematic Reports



 **Menu:** Projects ► Reports ► Report Format File Setup

 **Command entry:** AEFORMATFILE

Select Cable Summary from the Schematic report list.

### Category

By default, the report lists schematic components. Select a different Category to run the report for one-line, one-line bus-tap, hydraulic, pneumatic, P&ID, or user-defined components. These components are each identified by a unique [WDTYPE attribute](#) on page 325 value.

### Installation Codes to Extract

Extracts only the information for components with specific installation values. Indicate to process all components, components without an installation code, or only components marked with an installation code that matches that entered in the edit box. Wild-cards are supported.

Once you pick the Named Installation button, you can simply type the installation code in the box or click the List: Drawing or List: Project button to select from a list of used installation codes.

### Location Codes to Extract

Extracts only the information for components with specific location values. Indicate to process all components, components without a location code, or only components marked with a location code that matches that entered in the edit box. Wild-cards are supported.

Once you pick the Named Location button, you can simply type the location code in the box or click the List: Drawing or List: Project button to select from a list of used location codes.

### Report options

- **Save Report to File:** Saves the report to a file. Select the type of output file from the Save Report to File dialog box. You can define multiple file outputs using this dialog box. Choose from: ASCII report (.rep), Comma Delimited (.csv), Excel spreadsheet (.xls), Access database (.mdb), and XML (.xml) format.  
The First Section Only button indicates to only show the selected option (such as title line or time and date) on the first section of the report, if multiple sections are used. If not selected, the selected options will be shown on all report sections.
- **Change Report Fields:** Changes what data fields are reported and the order in which they appear. You can also change the justification of any column and even the column label. If you include the Description field in your report, you choose which lines make up this field. Just toggle on and off the specific fields to define the Description.
- **Put on Drawing:** Opens the Table Generation Setup dialog box for specifying how to display your report as a table on your drawing.
- **Sort Fields:** Controls the sorting order of the fields in the report.

---

**NOTE** The options are saved in the format file after you click OK on the subdialog boxes. If you are working in an unnamed format file, you have to save the data after you select Done in order to keep the changes you have made.

---

### Breaks

- **Special breaks:** Specifies the value that controls the section break. The drop-down list displays the report-specific content to apply to the special break.
- **Add Special break values to header:** Adds the special break value to the page header. For example, if you select a special break of

Installation/Location, the values provided for these devices in the schematic are displayed in the report section header.

### Format File

Format files define specific criteria applied to the report before generating the report to screen, printer, file, or automatic generation. The format files are saved to the 'Documents and Settings\{user name}' subdirectory or 'Users\{user name}' on a Windows Vista or Windows 7 installation.

- **Open Format File:** Selects format files to edit. The Report Format Settings File Selection dialog box opens and displays a list of format files (.set) in the user subdirectory. Select a file to edit from the list and click OK.

---

**NOTE** You cannot open format files created before AutoCAD Electrical 2005 for this report.

---

- **Save Format File:** Saves a format file on the hard disk for later retrieval and usage when generating reports.
- **Save As Format File:** Saves a format file that you opened and modified with a different name.

## Report format file setup - schematic PLC I/O component connection

 **Ribbon:** Reports tab ► Miscellaneous panel ► Report Format Setup.



 **Toolbar:** Schematic Reports

 **Menu:** Projects ► Reports ► Report Format File Setup

 **Command entry:** AEFORMATFILE

Select PLC I/O Component Connection from the Schematic report list.

### Installation Codes to Extract

Extracts only the information for components with specific installation values. Indicate to process all components, components without an installation code,

or only components marked with an installation code that matches that entered in the edit box. Wild-cards are supported.

Once you pick the Named Installation button, you can simply type the installation code in the box or click the List: Drawing or List: Project button to select from a list of used installation codes.

### **Location Codes to Extract**

Extracts only the information for components with specific location values. Indicate to process all components, components without a location code, or only components marked with a location code that matches that entered in the edit box. Wild-cards are supported.

Once you pick the Named Location button, you can simply type the location code in the box or click the List: Drawing or List: Project button to select from a list of used location codes.

### **Report options**

- **Save Report to File:** Saves the report to a file. Select the type of output file from the Save Report to File dialog box. You can define multiple file outputs using this dialog box. Choose from: ASCII report (.rep), Comma Delimited (.csv), Excel spreadsheet (.xls), Access database (.mdb), and XML (.xml) format.

The First Section Only button indicates to only show the selected option (such as title line or time and date) on the first section of the report, if multiple sections are used. If not selected, the selected options will be shown on all report sections.

- **Change Report Fields:** Changes what data fields are reported and the order in which they appear. You can also change the justification of any column and even the column label. If you include the Description field in your report, you choose which lines make up this field. Just toggle on and off the specific fields to define the Description.
- **Put on Drawing:** Opens the Table Generation Setup dialog box for specifying how to display your report as a table on your drawing.
- **Sort Fields:** Controls the sorting order of the fields in the report.

---

**NOTE** The options are saved in the format file after you click OK on the subdialog boxes. If you are working in an unnamed format file, you have to save the data after you select Done in order to keep the changes you have made.

---



## Breaks

- **Special breaks:** Specifies the value that controls the section break. The drop-down list displays the report-specific content to apply to the special break.
- **Add Special break values to header:** Adds the special break value to the page header. For example, if you select a special break of Installation/Location, the values provided for these devices in the schematic are displayed in the report section header.

## Format File

Format files define specific criteria applied to the report before generating the report to screen, printer, file, or automatic generation. The format files are saved to the 'Documents and Settings\{user name}' subdirectory or 'Users\{user name}' on a Windows Vista or Windows 7 installation.

- **Open Format File:** Selects format files to edit. The Report Format Settings File Selection dialog box opens and displays a list of format files (.set) in the user subdirectory. Select a file to edit from the list and click OK.

---

**NOTE** You cannot open format files created before AutoCAD Electrical 2005 for this report.

---

- **Save Format File:** Saves a format file on the hard disk for later retrieval and usage when generating reports.
- **Save As Format File:** Saves a format file that you opened and modified with a different name.

## Report format file setup - schematic component wire list

 **Ribbon:** Reports tab ► Miscellaneous panel ► Report Format Setup.



 **Toolbar:** Schematic Reports



 **Menu:** Projects ► Reports ► Report Format File Setup

 **Command entry:** AEFORMATFILE

Select Component Wire List from the Schematic report list.

### **Options**

Specifies to include stand-alone terminals or plug-jack connectors in the report.

### **Installation Codes to Extract**

Extracts only the information for components with specific installation values. Indicate to process all components, components without an installation code, or only components marked with an installation code that matches that entered in the edit box. Wild-cards are supported.

Once you pick the Named Installation button, you can simply type the installation code in the box or click the List: Drawing or List: Project button to select from a list of used installation codes.

### **Location Codes to Extract**

Extracts only the information for components with specific location values. Indicate to process all components, components without a location code, or only components marked with a location code that matches that entered in the edit box. Wild-cards are supported.

Once you pick the Named Location button, you can simply type the location code in the box or click the List: Drawing or List: Project button to select from a list of used location codes.

### **Report options**

- **Save Report to File:** Saves the report to a file. Select the type of output file from the Save Report to File dialog box. You can define multiple file outputs using this dialog box. Choose from: ASCII report (.rep), Comma Delimited (.csv), Excel spreadsheet (.xls), Access database (.mdb), and XML (.xml) format.  
The First Section Only button indicates to only show the selected option (such as title line or time and date) on the first section of the report, if multiple sections are used. If not selected, the selected options will be shown on all report sections.
- **Change Report Fields:** Changes what data fields are reported and the order in which they appear. You can also change the justification of any column and even the column label. If you include the Description field in your report, you choose which lines make up this field. Just toggle on and off the specific fields to define the Description.

- **Put on Drawing:** Opens the Table Generation Setup dialog box for specifying how to display your report as a table on your drawing.
- **Sort Fields:** Controls the sorting order of the fields in the report.

---

**NOTE** The options are saved in the format file after you click OK on the subdialog boxes. If you are working in an unnamed format file, you have to save the data after you select Done in order to keep the changes you have made.

---

### Breaks

- **Special breaks:** Specifies the value that controls the section break. The drop-down list displays the report-specific content to apply to the special break.
- **Add Special break values to header:** Adds the special break value to the page header. For example, if you select a special break of Installation/Location, the values provided for these devices in the schematic are displayed in the report section header.

### Format File

Format files define specific criteria applied to the report before generating the report to screen, printer, file, or automatic generation. The format files are saved to the 'Documents and Settings\{user name}' subdirectory or 'Users\{user name}' on a Windows Vista or Windows 7 installation.

- **Open Format File:** Selects format files to edit. The Report Format Settings File Selection dialog box opens and displays a list of format files (.set) in the user subdirectory. Select a file to edit from the list and click OK.

---

**NOTE** You cannot open format files created before AutoCAD Electrical 2005 for this report.

---

- **Save Format File:** Saves a format file on the hard disk for later retrieval and usage when generating reports.
- **Save As Format File:** Saves a format file that you opened and modified with a different name.

## Report format file setup - schematic connector details

 **Ribbon:** Reports tab ► Miscellaneous panel ► Report Format Setup.



 **Toolbar:** Schematic Reports



 **Menu:** Projects ► Reports ► Report Format File Setup

 **Command entry:** AEFORMATFILE

Select Connector Details from the Schematic report list.

### Category

By default, the report lists schematic components. Select a different Category to run the report for one-line, one-line bus-tap, hydraulic, pneumatic, P&ID, or user-defined components. These components are each identified by a unique [WDTYPE attribute](#) on page 325 value.

### Installation Codes to Extract

Extracts only the information for components with specific installation values. Indicate to process all components, components without an installation code, or only components marked with an installation code that matches that entered in the edit box. Wild-cards are supported.

Once you pick the Named Installation button, you can simply type the installation code in the box or click the List: Drawing or List: Project button to select from a list of used installation codes.

### Location Codes to Extract

Extracts only the information for components with specific location values. Indicate to process all components, components without a location code, or only components marked with a location code that matches that entered in the edit box. Wild-cards are supported.

Once you pick the Named Location button, you can simply type the location code in the box or click the List: Drawing or List: Project button to select from a list of used location codes.

### Report options

- **Save Report to File:** Saves the report to a file. Select the type of output file from the Save Report to File dialog box. You can define multiple file outputs

using this dialog box. Choose from: ASCII report (.rep), Comma Delimited (.csv), Excel spreadsheet (.xls), Access database (.mdb), and XML (.xml) format.

The First Section Only button indicates to only show the selected option (such as title line or time and date) on the first section of the report, if multiple sections are used. If not selected, the selected options will be shown on all report sections.

- **Change Report Fields:** Changes what data fields are reported and the order in which they appear. You can also change the justification of any column and even the column label. If you include the Description field in your report, you choose which lines make up this field. Just toggle on and off the specific fields to define the Description.
- **Put on Drawing:** Opens the Table Generation Setup dialog box for specifying how to display your report as a table on your drawing.
- **Sort Fields:** Controls the sorting order of the fields in the report.

---

**NOTE** The options are saved in the format file after you click OK on the subdialog boxes. If you are working in an unnamed format file, you have to save the data after you select Done in order to keep the changes you have made.

---

### Breaks

- **Special breaks:** Specifies the value that controls the section break. The drop-down list displays the report-specific content to apply to the special break.
- **Add Special break values to header:** Adds the special break value to the page header. For example, if you select a special break of Installation/Location, the values provided for these devices in the schematic are displayed in the report section header.

### Format File

Format files define specific criteria applied to the report before generating the report to screen, printer, file, or automatic generation. The format files are saved to the 'Documents and Settings\{user name}' subdirectory or 'Users\{user name}' on a Windows Vista or Windows 7 installation.

- **Open Format File:** Selects format files to edit. The Report Format Settings File Selection dialog box opens and displays a list of format files (.set) in the user subdirectory. Select a file to edit from the list and click OK.

- **Save Format File:** Saves a format file on the hard disk for later retrieval and usage when generating reports.
- **Save As Format File:** Saves a format file that you opened and modified with a different name.

## Report format file setup - schematic connector plug

 **Ribbon:** Reports tab ► Miscellaneous panel ► Report Format Setup.



 **Toolbar:** Schematic Reports



 **Menu:** Projects ► Reports ► Report Format File Setup

 **Command entry:** AEFORMATFILE

Select Connector Plug from the Schematic report list.

### Category

By default, the report lists schematic components. Select a different Category to run the report for one-line, one-line bus-tap, hydraulic, pneumatic, P&ID, or user-defined components. These components are each identified by a unique [WDTYPE attribute](#) on page 325 value.

### Installation Codes to Extract

Extracts only the information for components with specific installation values. Indicate to process all components, components without an installation code, or only components marked with an installation code that matches that entered in the edit box. Wild-cards are supported.

Once you pick the Named Installation button, you can simply type the installation code in the box or click the List: Drawing or List: Project button to select from a list of used installation codes.

### Location Codes to Extract

Extracts only the information for components with specific location values. Indicate to process all components, components without a location code, or

only components marked with a location code that matches that entered in the edit box. Wild-cards are supported.

Once you pick the Named Location button, you can simply type the location code in the box or click the List: Drawing or List: Project button to select from a list of used location codes.

### Report options

- **Save Report to File:** Saves the report to a file. Select the type of output file from the Save Report to File dialog box. You can define multiple file outputs using this dialog box. Choose from: ASCII report (.rep), Comma Delimited (.csv), Excel spreadsheet (.xls), Access database (.mdb), and XML (.xml) format.

The First Section Only button indicates to only show the selected option (such as title line or time and date) on the first section of the report, if multiple sections are used. If not selected, the selected options will be shown on all report sections.

- **Change Report Fields:** Changes what data fields are reported and the order in which they appear. You can also change the justification of any column and even the column label. If you include the Description field in your report, you choose which lines make up this field. Just toggle on and off the specific fields to define the Description.
- **Put on Drawing:** Opens the Table Generation Setup dialog box for specifying how to display your report as a table on your drawing.
- **Sort Fields:** Controls the sorting order of the fields in the report.

---

**NOTE** The options are saved in the format file after you click OK on the subdialog boxes. If you are working in an unnamed format file, you have to save the data after you select Done in order to keep the changes you have made.

---

### Breaks

- **Special breaks:** Specifies the value that controls the section break. The drop-down list displays the report-specific content to apply to the special break.
- **Add Special break values to header:** Adds the special break value to the page header. For example, if you select a special break of Installation/Location, the values provided for these devices in the schematic are displayed in the report section header.

## Format File

Format files define specific criteria applied to the report before generating the report to screen, printer, file, or automatic generation. The format files are saved to the 'Documents and Settings\{user name}' subdirectory or 'Users\{user name}' on a Windows Vista or Windows 7 installation.

- **Open Format File:** Selects format files to edit. The Report Format Settings File Selection dialog box opens and displays a list of format files (.set) in the user subdirectory. Select a file to edit from the list and click OK.
- **Save Format File:** Saves a format file on the hard disk for later retrieval and usage when generating reports.
- **Save As Format File:** Saves a format file that you opened and modified with a different name.

## Report format file setup - schematic connector summary

 **Ribbon:** Reports tab ► Miscellaneous panel ► Report Format Setup.



 **Toolbar:** Schematic Reports

 **Menu:** Projects ► Reports ► Report Format File Setup

 **Command entry:** AEFORMATFILE

Select Connector Summary from the Schematic report list.

## Category

By default, the report lists schematic components. Select a different Category to run the report for one-line, one-line bus-tap, hydraulic, pneumatic, P&ID, or user-defined components. These components are each identified by a unique [WDTYPE attribute](#) on page 325 value.

## Installation Codes to Extract

Extracts only the information for components with specific installation values. Indicate to process all components, components without an installation code, or only components marked with an installation code that matches that entered in the edit box. Wild-cards are supported.



Once you pick the Named Installation button, you can simply type the installation code in the box or click the List: Drawing or List: Project button to select from a list of used installation codes.

### **Location Codes to Extract**

Extracts only the information for components with specific location values. Indicate to process all components, components without a location code, or only components marked with a location code that matches that entered in the edit box. Wild-cards are supported.

Once you pick the Named Location button, you can simply type the location code in the box or click the List: Drawing or List: Project button to select from a list of used location codes.

### **Report options**

- **Save Report to File:** Saves the report to a file. Select the type of output file from the Save Report to File dialog box. You can define multiple file outputs using this dialog box. Choose from: ASCII report (.rep), Comma Delimited (.csv), Excel spreadsheet (.xls), Access database (.mdb), and XML (.xml) format.  
The First Section Only button indicates to only show the selected option (such as title line or time and date) on the first section of the report, if multiple sections are used. If not selected, the selected options will be shown on all report sections.
- **Change Report Fields:** Changes what data fields are reported and the order in which they appear. You can also change the justification of any column and even the column label. If you include the Description field in your report, you choose which lines make up this field. Just toggle on and off the specific fields to define the Description.
- **Put on Drawing:** Opens the Table Generation Setup dialog box for specifying how to display your report as a table on your drawing.
- **Sort Fields:** Controls the sorting order of the fields in the report.

---

**NOTE** The options are saved in the format file after you click OK on the subdialog boxes. If you are working in an unnamed format file, you have to save the data after you select Done in order to keep the changes you have made.

---

## Breaks

- **Special breaks:** Specifies the value that controls the section break. The drop-down list displays the report-specific content to apply to the special break.
- **Add Special break values to header:** Adds the special break value to the page header. For example, if you select a special break of Installation/Location, the values provided for these devices in the schematic are displayed in the report section header.

## Format File

Format files define specific criteria applied to the report before generating the report to screen, printer, file, or automatic generation. The format files are saved to the 'Documents and Settings\{user name}' subdirectory or 'Users\{user name}' on a Windows Vista or Windows 7 installation.

- **Open Format File:** Selects format files to edit. The Report Format Settings File Selection dialog box opens and displays a list of format files (.set) in the user subdirectory. Select a file to edit from the list and click OK.
- **Save Format File:** Saves a format file on the hard disk for later retrieval and usage when generating reports.
- **Save As Format File:** Saves a format file that you opened and modified with a different name.

## Report format file setup - schematic component

 **Ribbon:** Reports tab ► Miscellaneous panel ► Report Format Setup.



 **Toolbar:** Schematic Reports



 **Menu:** Projects ► Reports ► Report Format File Setup

 **Command entry:** AEFORMATFILE

Select Component from the Schematic report list.

## Category

By default, the report lists schematic components. Select a different Category to run the report for one-line, one-line bus-tap, hydraulic, pneumatic, P&ID, or user-defined components. These components are each identified by a unique [WDTYPE attribute](#) on page 325 value.

## Options

Specifies whether to include components, cable markers, or connectors in the report. You can also indicate to include the children for any of the selected options.

## Installation Codes to Extract

Extracts only the information for components with specific installation values. Indicate to process all components, components without an installation code, or only components marked with an installation code that matches that entered in the edit box. Wild-cards are supported.

Once you pick the Named Installation button, you can simply type the installation code in the box or click the List: Drawing or List: Project button to select from a list of used installation codes.

## Location Codes to Extract

Extracts only the information for components with specific location values. Indicate to process all components, components without a location code, or only components marked with a location code that matches that entered in the edit box. Wild-cards are supported.

Once you pick the Named Location button, you can simply type the location code in the box or click the List: Drawing or List: Project button to select from a list of used location codes.

## Report options

- **Save Report to File:** Saves the report to a file. Select the type of output file from the Save Report to File dialog box. You can define multiple file outputs using this dialog box. Choose from: ASCII report (.rep), Comma Delimited (.csv), Excel spreadsheet (.xls), Access database (.mdb), and XML (.xml) format.

The First Section Only button indicates to only show the selected option (such as title line or time and date) on the first section of the report, if multiple sections are used. If not selected, the selected options will be shown on all report sections.

- **Change Report Fields:** Changes what data fields are reported and the order in which they appear. You can also change the justification of any column and even the column label. If you include the Description field in your report, you choose which lines make up this field. Just toggle on and off the specific fields to define the Description.
- **Put on Drawing:** Opens the Table Generation Setup dialog box for specifying how to display your report as a table on your drawing.
- **Sort Fields:** Controls the sorting order of the fields in the report.

---

**NOTE** The options are saved in the format file after you click OK on the subdialog boxes. If you are working in an unnamed format file, you have to save the data after you select Done in order to keep the changes you have made.

---

### Breaks

- **Special breaks:** Specifies the value that controls the section break. The drop-down list displays the report-specific content to apply to the special break.
- **Add Special break values to header:** Adds the special break value to the page header. For example, if you select a special break of Installation/Location, the values provided for these devices in the schematic are displayed in the report section header.

### Format File

Format files define specific criteria applied to the report before generating the report to screen, printer, file, or automatic generation. The format files are saved to the 'Documents and Settings\{user name}' subdirectory or 'Users\{user name}' on a Windows Vista or Windows 7 installation.

- **Open Format File:** Selects format files to edit. The Report Format Settings File Selection dialog box opens and displays a list of format files (.set) in the user subdirectory. Select a file to edit from the list and click OK.
- **Save Format File:** Saves a format file on the hard disk for later retrieval and usage when generating reports.
- **Save As Format File:** Saves a format file that you opened and modified with a different name.

## **Report format file setup - schematic missing bill of material**

 **Ribbon:** Reports tab ► Miscellaneous panel ► Report Format Setup.



 **Toolbar:** Schematic Reports



 **Menu:** Projects ► Reports ► Report Format File Setup

 **Command entry:** AEFORMATFILE

Select Missing Bill of Material from the Schematic report list.

### Category

By default, the report lists schematic components. Select a different Category to run the report for one-line, one-line bus-tap, hydraulic, pneumatic, P&ID, or user-defined components. These components are each identified by a unique [WDTYPE attribute](#) on page 325 value.

### Options

Specifies whether to include components, cable markers, connectors, or terminals in the report. You can select one or multiple options to include.

### Installation Codes to Extract

Extracts only the information for components with specific installation values. Indicate to process all components, components without an installation code, or only components marked with an installation code that matches that entered in the edit box. Wild-cards are supported.

Once you pick the Named Installation button, you can simply type the installation code in the box or click the List: Drawing or List: Project button to select from a list of used installation codes.

### Location Codes to Extract

Extracts only the information for components with specific location values. Indicate to process all components, components without a location code, or only components marked with a location code that matches that entered in the edit box. Wild-cards are supported.

Once you pick the Named Location button, you can simply type the location code in the box or click the List: Drawing or List: Project button to select from a list of used location codes.

## Report options

- **Save Report to File:** Saves the report to a file. Select the type of output file from the Save Report to File dialog box. You can define multiple file outputs using this dialog box. Choose from: ASCII report (.rep), Comma Delimited (.csv), Excel spreadsheet (.xls), Access database (.mdb), and XML (.xml) format.  
The First Section Only button indicates to only show the selected option (such as title line or time and date) on the first section of the report, if multiple sections are used. If not selected, the selected options will be shown on all report sections.
- **Change Report Fields:** Changes what data fields are reported and the order in which they appear. You can also change the justification of any column and even the column label. The Description field is handled a little differently than the other fields. This field can be a multi-line field which is actually made up of multiple fields. If you include the Description field in your report, you choose which lines make up this field. Just toggle on and off the specific fields to define the Description.
- **Put on Drawing:** Opens the Table Generation Setup dialog box for specifying how to display your report as a table on your drawing.
- **Sort Fields:** Controls the sorting order of the fields in the report.

---

**NOTE** The options are saved in the format file after you click OK on the subdialog boxes. If you are working in an unnamed format file, you have to save the data after you select Done in order to keep the changes you have made.

---

## Breaks

- **Special breaks:** Specifies the value that controls the section break. The drop-down list displays the report-specific content to apply to the special break.
- **Add Special break values to header:** Adds the special break value to the page header. For example, if you select a special break of Installation/Location, the values provided for these devices in the schematic are displayed in the report section header.

## Format File

Format files define specific criteria applied to the report before generating the report to screen, printer, file, or automatic generation. The format files are

saved to the 'Documents and Settings\{user name}' subdirectory or 'Users\{user name}' on a Windows Vista or Windows 7 installation.

- **Open Format File:** Selects format files to edit. The Report Format Settings File Selection dialog box opens and displays a list of format files (.set) in the user subdirectory. Select a file to edit from the list and click OK.
- **Save Format File:** Saves a format file on the hard disk for later retrieval and usage when generating reports.
- **Save As Format File:** Saves a format file that you opened and modified with a different name.

## Report format file setup - schematic wire from/to

 **Ribbon:** Reports tab ► Miscellaneous panel ► Report Format Setup.



 **Toolbar:** Schematic Reports



 **Menu:** Projects ► Reports ► Report Format File Setup

 **Command entry:** AEFORMATFILE

Select Wire From/To from the Schematic report list.

### Category

By default, the report lists schematic components. Select a different Category to run the report for one-line, one-line bus-tap, hydraulic, pneumatic, P&ID, or user-defined components. These components are each identified by a unique [WDTYPE attribute](#) on page 325 value.

### Report options

- **Save Report to File:** Saves the report to a file. Select the type of output file from the Save Report to File dialog box. You can define multiple file outputs using this dialog box. Choose from: ASCII report (.rep), Comma Delimited (.csv), Excel spreadsheet (.xls), Access database (.mdb), and XML (.xml) format.  
The First Section Only button indicates to only show the selected option (such as title line or time and date) on the first section of the report, if

multiple sections are used. If not selected, the selected options will be shown on all report sections.

- **Change Report Fields:** Changes what data fields are reported and the order in which they appear. You can also change the justification of any column and even the column label. If you include the Description field in your report, you choose which lines make up this field. Just toggle on and off the specific fields to define the Description.
- **Put on Drawing:** Opens the Table Generation Setup dialog box for specifying how to display your report as a table on your drawing.
- **Sort Fields:** Controls the sorting order of the fields in the report.

---

**NOTE** The options are saved in the format file after you click OK on the subdialog boxes. If you are working in an unnamed format file, you have to save the data after you select Done in order to keep the changes you have made.

---

### Format File

Format files define specific criteria applied to the report before generating the report to screen, printer, file, or automatic generation. The format files are saved to the 'Documents and Settings\{user name}' subdirectory or 'Users\{user name}' on a Windows Vista or Windows 7 installation.

- **Open Format File:** Selects format files to edit. The Report Format Settings File Selection dialog box opens and displays a list of format files (.set) in the user subdirectory. Select a file to edit from the list and click OK.
- **Save Format File:** Saves a format file on the hard disk for later retrieval and usage when generating reports.
- **Save As Format File:** Saves a format file that you opened and modified with a different name.

## Report format file setup - schematic PLC/IO address and descriptions

 **Ribbon:** Reports tab ► Miscellaneous panel ► Report Format Setup.







 **Toolbar:** Schematic Reports

 **Menu:** Projects ► Reports ► Report Format File Setup

 **Command entry:** AEFORMATFILE

Select PLC I/O Address and Descriptions from the Schematic report list.

### Installation Codes to Extract

Extracts only the information for components with specific installation values. Indicate to process all components, components without an installation code, or only components marked with an installation code that matches that entered in the edit box. Wild-cards are supported.

Once you pick the Named Installation button, you can simply type the installation code in the box or click the List: Drawing or List: Project button to select from a list of used installation codes.

### Location Codes to Extract

Extracts only the information for components with specific location values. Indicate to process all components, components without a location code, or only components marked with a location code that matches that entered in the edit box. Wild-cards are supported.

Once you pick the Named Location button, you can simply type the location code in the box or click the List: Drawing or List: Project button to select from a list of used location codes.

### Report options

- **Save Report to File:** Saves the report to a file. Select the type of output file from the Save Report to File dialog box. You can define multiple file outputs using this dialog box. Choose from: ASCII report (.rep), Comma Delimited (.csv), Excel spreadsheet (.xls), Access database (.mdb), and XML (.xml) format.

The First Section Only button indicates to only show the selected option (such as title line or time and date) on the first section of the report, if multiple sections are used. If not selected, the selected options will be shown on all report sections.

- **Change Report Fields:** Changes what data fields are reported and the order in which they appear. You can also change the justification of any column and even the column label. If you include the Description field in your

report, you choose which lines make up this field. Just toggle on and off the specific fields to define the Description.

- **Put on Drawing:** Opens the Table Generation Setup dialog box for specifying how to display your report as a table on your drawing.
- **Sort Fields:** Controls the sorting order of the fields in the report.

---

**NOTE** The options are saved in the format file after you click OK on the subdialog boxes. If you are working in an unnamed format file, you have to save the data after you select Done in order to keep the changes you have made.

---

### Breaks

- **Special breaks:** Specifies the value that controls the section break. The drop-down list displays the report-specific content to apply to the special break.
- **Add Special break values to header:** Adds the special break value to the page header. For example, if you select a special break of Installation/Location, the values provided for these devices in the schematic are displayed in the report section header.

### Format File

Format files define specific criteria applied to the report before generating the report to screen, printer, file, or automatic generation. The format files are saved to the 'Documents and Settings\{user name}' subdirectory or 'Users\{user name}' on a Windows Vista or Windows 7 installation.

- **Open Format File:** Selects format files to edit. The Report Format Settings File Selection dialog box opens and displays a list of format files (.set) in the user subdirectory. Select a file to edit from the list and click OK.
- **Save Format File:** Saves a format file on the hard disk for later retrieval and usage when generating reports.
- **Save As Format File:** Saves a format file that you opened and modified with a different name.

## Report format file setup - schematic terminal numbers

 **Ribbon:** Reports tab ► Miscellaneous panel ► Report Format Setup.



 **Toolbar:** Schematic Reports



 **Menu:** Projects ► Reports ► Report Format File Setup

 **Command entry:** AEFORMATFILE

Select Terminal Numbers from the Schematic report list.

### Installation Codes to Extract

Extracts only the information for components with specific installation values. Indicate to process all components, components without an installation code, or only components marked with an installation code that matches that entered in the edit box. Wild-cards are supported.

Once you pick the Named Installation button, you can simply type the installation code in the box or click the List: Drawing or List: Project button to select from a list of used installation codes.

### Location Codes to Extract

Extracts only the information for components with specific location values. Indicate to process all components, components without a location code, or only components marked with a location code that matches that entered in the edit box. Wild-cards are supported.

Once you pick the Named Location button, you can simply type the location code in the box or click the List: Drawing or List: Project button to select from a list of used location codes.

### Report options

■ **Save Report to File:** Saves the report to a file. Select the type of output file from the Save Report to File dialog box. You can define multiple file outputs using this dialog box. Choose from: ASCII report (.rep), Comma Delimited (.csv), Excel spreadsheet (.xls), Access database (.mdb), and XML (.xml) format.

The First Section Only button indicates to only show the selected option (such as title line or time and date) on the first section of the report, if

multiple sections are used. If not selected, the selected options will be shown on all report sections.

- **Change Report Fields:** Changes what data fields are reported and the order in which they appear. You can also change the justification of any column and even the column label. If you include the Description field in your report, you choose which lines make up this field. Just toggle on and off the specific fields to define the Description.
- **Put on Drawing:** Opens the Table Generation Setup dialog box for specifying how to display your report as a table on your drawing.
- **Sort Fields:** Controls the sorting order of the fields in the report.

---

**NOTE** The options are saved in the format file after you click OK on the subdialog boxes. If you are working in an unnamed format file, you have to save the data after you select Done in order to keep the changes you have made.

---

### Breaks

- **Special breaks:** Specifies the value that controls the section break. The drop-down list displays the report-specific content to apply to the special break.
- **Add Special break values to header:** Adds the special break value to the page header. For example, if you select a special break of Installation/Location, the values provided for these devices in the schematic are displayed in the report section header.

### Format File

Format files define specific criteria applied to the report before generating the report to screen, printer, file, or automatic generation. The format files are saved to the 'Documents and Settings\{user name}' subdirectory or 'Users\{user name}' on a Windows Vista or Windows 7 installation.

- **Open Format File:** Selects format files to edit. The Report Format Settings File Selection dialog box opens and displays a list of format files (.set) in the user subdirectory. Select a file to edit from the list and click OK.
- **Save Format File:** Saves a format file on the hard disk for later retrieval and usage when generating reports.
- **Save As Format File:** Saves a format file that you opened and modified with a different name.

## Report format file setup - schematic terminal plan

 **Ribbon:** Reports tab ► Miscellaneous panel ► Report Format Setup.



 **Toolbar:** Schematic Reports

 **Menu:** Projects ► Reports ► Report Format File Setup

 **Command entry:** AEFORMATFILE

Select Terminal Plan from the Schematic report list.

### Installation Codes to Extract

Extracts only the information for components with specific installation values. Indicate to process all components, components without an installation code, or only components marked with an installation code that matches that entered in the edit box. Wild-cards are supported.

Once you pick the Named Installation button, you can simply type the installation code in the box or click the List: Drawing or List: Project button to select from a list of used installation codes.

### Location Codes to Extract

Extracts only the information for components with specific location values. Indicate to process all components, components without a location code, or only components marked with a location code that matches that entered in the edit box. Wild-cards are supported.

Once you pick the Named Location button, you can simply type the location code in the box or click the List: Drawing or List: Project button to select from a list of used location codes.

### Report options

■ **Save Report to File:** Saves the report to a file. Select the type of output file from the Save Report to File dialog box. You can define multiple file outputs using this dialog box. Choose from: ASCII report (.rep), Comma Delimited (.csv), Excel spreadsheet (.xls), Access database (.mdb), and XML (.xml) format.

The First Section Only button indicates to only show the selected option (such as title line or time and date) on the first section of the report, if

multiple sections are used. If not selected, the selected options will be shown on all report sections.

- **Change Report Fields:** Changes what data fields are reported and the order in which they appear. You can also change the justification of any column and even the column label. If you include the Description field in your report, you choose which lines make up this field. Just toggle on and off the specific fields to define the Description.
- **Put on Drawing:** Opens the Table Generation Setup dialog box for specifying how to display your report as a table on your drawing.
- **Sort Fields:** Controls the sorting order of the fields in the report.

---

**NOTE** The options are saved in the format file after you click OK on the subdialog boxes. If you are working in an unnamed format file, you have to save the data after you select Done in order to keep the changes you have made.

---

### Breaks

- **Special breaks:** Specifies the value that controls the section break. The drop-down list displays the report-specific content to apply to the special break.
- **Add Special break values to header:** Adds the special break value to the page header. For example, if you select a special break of Installation/Location, the values provided for these devices in the schematic are displayed in the report section header.

### Format File

Format files define specific criteria applied to the report before generating the report to screen, printer, file, or automatic generation. The format files are saved to the 'Documents and Settings\{user name}' subdirectory or 'Users\{user name}' on a Windows Vista or Windows 7 installation.

- **Open Format File:** Selects format files to edit. The Report Format Settings File Selection dialog box opens and displays a list of format files (.set) in the user subdirectory. Select a file to edit from the list and click OK.

---

**NOTE** You cannot open format files created before AutoCAD Electrical 2005 for this report.

---

- **Save Format File:** Saves a format file on the hard disk for later retrieval and usage when generating reports.

- **Save As Format File:** Saves a format file that you opened and modified with a different name.

## Report format file setup - schematic PLC modules used so far

 **Ribbon:** Reports tab ► Miscellaneous panel ► Report Format Setup.



 **Toolbar:** Schematic Reports

 **Menu:** Projects ► Reports ► Report Format File Setup

 **Command entry:** AEFORMATFILE

Select PLC Modules Used So Far from the Schematic report list.

### Installation Codes to Extract

Extracts only the information for components with specific installation values. Indicate to process all components, components without an installation code, or only components marked with an installation code that matches that entered in the edit box. Wild-cards are supported.

Once you pick the Named Installation button, you can simply type the installation code in the box or click the List: Drawing or List: Project button to select from a list of used installation codes.

### Location Codes to Extract

Extracts only the information for components with specific location values. Indicate to process all components, components without a location code, or only components marked with a location code that matches that entered in the edit box. Wild-cards are supported.

Once you pick the Named Location button, you can simply type the location code in the box or click the List: Drawing or List: Project button to select from a list of used location codes.

### Report options

- **Save Report to File:** Saves the report to a file. Select the type of output file from the Save Report to File dialog box. You can define multiple file outputs using this dialog box. Choose from: ASCII report (.rep), Comma Delimited

(.csv), Excel spreadsheet (.xls), Access database (.mdb), and XML (.xml) format.

The First Section Only button indicates to only show the selected option (such as title line or time and date) on the first section of the report, if multiple sections are used. If not selected, the selected options will be shown on all report sections.

- **Change Report Fields:** Changes what data fields are reported and the order in which they appear. You can also change the justification of any column and even the column label. If you include the Description field in your report, you choose which lines make up this field. Just toggle on and off the specific fields to define the Description.
- **Put on Drawing:** Opens the Table Generation Setup dialog box for specifying how to display your report as a table on your drawing.
- **Sort Fields:** Controls the sorting order of the fields in the report.

---

**NOTE** The options are saved in the format file after you click OK on the subdialog boxes. If you are working in an unnamed format file, you have to save the data after you select Done in order to keep the changes you have made.

---

### Breaks

- **Special breaks:** Specifies the value that controls the section break. The drop-down list displays the report-specific content to apply to the special break.
- **Add Special break values to header:** Adds the special break value to the page header. For example, if you select a special break of Installation/Location, the values provided for these devices in the schematic are displayed in the report section header.

### Format File

Format files define specific criteria applied to the report before generating the report to screen, printer, file, or automatic generation. The format files are saved to the 'Documents and Settings\{user name}' subdirectory or 'Users\{user name}' on a Windows Vista or Windows 7 installation.

- **Open Format File:** Selects format files to edit. The Report Format Settings File Selection dialog box opens and displays a list of format files (.set) in the user subdirectory. Select a file to edit from the list and click OK.



- **Save Format File:** Saves a format file on the hard disk for later retrieval and usage when generating reports.
- **Save As Format File:** Saves a format file that you opened and modified with a different name.

## Report format file setup - schematic wire label

The options are saved in the format file after you click OK on the dialog boxes. If you are working in an unnamed format file, you must save the data after you click Done to keep the changes you made.

 **Ribbon:** Reports tab ► Miscellaneous panel ► Report Format Setup.



 **Toolbar:** Schematic Reports

 **Menu:** Projects ► Reports ► Report Format File Setup

 **Command entry:** AEFORMATFILE

Select Wire Label from the Schematic report list.

### Report Filter

**Display Wire Label**

Displays the wire label for all wires, except those that are part of a cable.

**Display Cable Label**

Displays the cable labels in the specified format.

### Change Report Fields

Changes which data fields are reported and the order in which they appear. You can change the justification of any column and the column label.

There are two categories that you can change the report format for: wire label or cable label. Once you modify the report format, you can save it for future use. The wire and cable label formats are stored in the same file.

### **Label Quantity per Connection**

Specifies the quantity of wire labels or cable labels. Wire labels are generated for every wire connection while cable labels are generated once for every cable.

### **Number of Columns to Display**

Arranges the wire labels in the specified number of columns.

### **Horizontal/Vertical Arrangement**

Arranges the wire label horizontally or vertically across the columns.

### **Save Report to File**

Saves the report to a file. Select the type of output file from the Save Report to File dialog box. You can define multiple file outputs. Choose from: ASCII report (.rep), Comma Delimited (.csv), Excel spreadsheet (.xls), Access database (.mdb), and XML (.xml) format.

First Section Only shows only the selected option (such as title line or time and date) on the first section of the report if multiple sections are used. If not checked, the selected options are shown on all report sections.

### **Put on Drawing**

Opens the Table Generation Setup dialog box for specifying how to display your report as a table on your drawing.

---

**NOTE** Once wire label reports are placed on the drawing in table format they are not editable using the Edit Component tool. You must use the AutoCAD table edit command to edit the table.

---

### **Breaks**

#### **Special Breaks**

Specifies the value that controls the section break. The list displays the report-specific content to apply to the special break.

#### **Add Special Break Values to Header**

Adds the special break value to the page header. For example, if you select a special break of Installation/Location, the values provided for these devices in the schematic are displayed in the report section header.

### **Installation Codes to Extract**

Extracts only the information for components with specific installation values. Indicate to process all components, components without an installation code, or only components marked with an installation code that matches that entered in the edit box. Wild-cards are supported.

Once you click Named Installation, you can type the installation code in the box or click List: Drawing or List: Project to select from a list of used installation codes.

### **Location Codes to Extract**

Extracts only the information for components with specific location values. Indicate to process all components, components without a location code, or only components marked with a location code that matches that entered in the edit box. Wild-cards are supported.

Once you click Named Location, you can type the location code in the box or click List: Drawing or List: Project to select from a list of used location codes.

### **Format File**

Format files define specific criteria applied to the report before generating the report to screen, printer, file, or automatic generation. The format files are saved to the 'Documents and Settings\{user name}' subdirectory or 'Users\{user name}' on a Windows Vista or Windows 7 installation.

<b>Open Format File</b>	Selects format files to edit. The Report Format Settings File Selection dialog box opens and displays a list of format files (.set) in the user subdirectory. Select a file to edit from the list and click OK.
<b>Save Format File</b>	Saves a format file on the hard drive for later retrieval and usage when generating reports.
<b>Save As Format File</b>	Saves a format file that you opened and modified with a different name.

## **Run automatic reports**

The Automatic Report Selection tool allows you to run multiple reports at one time. The Report Generator dialog box is not displayed for each report and no user input is required once launched. This feature can be used to generate

any number of output files or to automatically place report tables on drawings. The first step to using the Automatic Reports feature is to create the format files using the Report Format File Setup dialog box defining the report options and output as described above. You can create any number of format files for the same report if you use the same report with different options. Once your format files are created you are ready to run the reports automatically.

If any of your selected format files contain Table Output, if there are no existing, updatable matching report tables, the report tables insert on new drawings. If you are running multiple reports with multiple table output, each report gets its own. You can specify the first drawing name for any necessary new drawings and the template name. Subsequent drawing names generate automatically by incrementing the previous drawing's name.

If you frequently run the same group of reports you can save the set of format files as a Report Grouping. To set up a Report Grouping, add all your format files as if you are going to run the reports then click Save Report Grouping. The information about the format files is saved in a Report Grouping file with an ".rgf" extension. The next time you want to run that report set, open the Automatic Reports Selection dialog box, click Open Report Grouping, and select the ".rgf" file you previously saved; you are ready to run the reports.

When you click OK, the reports run in the selected order. If the format file contains output options, the files are created. If the format file contains table output options that report's tables are inserted. If existing, matching report tables are found, they are updated, otherwise new table objects insert on new drawings.

## Generate a report using format files



- 1 Click Reports tab ► Miscellaneous panel ► Automatic Reports.
- 2 Select which report to generate from the schematic or panel report list.
- 3 Specify the format file to use for the selected report. If there aren't any format files to select from, you must click the Format File Setup button to create and save a format file.
- 4 Click the Add button to add the report name and format file to the Selected Reports list. This button is not active until both a report name and format file are selected.
- 5 Continue adding more reports to the Selected Reports list.

For the File and Table Output options, an 'X' indicates that the automatic generation will run that portion, while an 'O' indicates that it will not run that portion.

- 6 Modify the output of a report type by selecting the report in the Selected Reports list and then clicking the Modify Output button. Make changes in the subdialog box and click OK.
- 7 Save the list of report names and format files for later retrieval and usage.
- 8 Specify a starting drawing file location and filename, and the drawing template file to use for the automatic creation of the drawing files.
- 9 Click OK to generate a report for the selected type(s).

## Automatic report selection

Defines a list of reports and their format files, and runs the reports automatically.

 **Ribbon:** Reports tab ► Miscellaneous panel ► Automatic Reports.



 **Toolbar:** Schematic Reports



 **Menu:** Projects ► Reports ► Automatic Report Selection

 **Command entry:** AEAUTOREPORT

Automatic Report Selection generates any number of output files, and places report tables on drawings. You select the desired reports and click OK.

---

**NOTE** All drawings are automatically added to the bottom of the Project Listing.

---

### Report Name

Displays a list of all schematic and panel reports available for automatic report generation. Not every AutoCAD Electrical report is available for this command.

### Format File Name

Displays a list of format files. These format files are associated with a particular report name. If there aren't any format files to select from, you must click the Format File Setup button to create and save a format file.

The Browse button allows you to search for a specific format file that is not displayed in the list.

### Control buttons

- **Modify Output:** Changes the output types for individually selected reports. Each format file definition can determine whether the report is set to a file or table on the drawing, or both. Select a file in the Selected Reports list, click the Modify Output button, and click either of the toggle buttons to turn on or off the output type.
- **Add:** Adds the report name and format file to the Selected Reports list. This button is not active until both a report name and format file are selected.
- **Remove:** Removes individual reports from the Selected Reports list. Select the file from the list so that it is highlighted and press the Remove button.
- **Remove All:** Removes all of the reports from the Selected Reports list. There is no need to select the files in the list; simply press the Remove All button.

### Selected Reports

Displays the current active listing of all reports for the report generation. The list displays the report name and format file name, as well as indicators that show if the report output is a file or table.

For the File and Table Output options, an 'X' indicates that the automatic generation will run that portion, while an 'O' indicates that it will not run that portion.

### Open or Save Report Grouping

Allows you to define an alias (grouping) file with a pre-defined list of reports for later retrieval and usage. You can make many grouping files for different customer types and configurations. The Report Grouping files are maintained in the Documents and Settings\{user name} subdirectory or Users\{user name} on a Windows Vista or Windows 7 installation. The file names have an .rgf file extension.

- **Open Report Grouping:** Opens a previously saved grouping of report names and format files.
- **Save Report Grouping:** Saves a file that contains the list of report names and format files for later retrieval and usage. You may define a list of reports based upon which customer is using the report data and the format that customer would like to see the reports in.

### Drawing Information for Table Output

Specifies a starting drawing file location and filename, and the drawing template file to use for the automatic creation of the drawing files. You can select a template drawing file to use for the automatic creation of drawing files. Type in a template filename or use the Browse button to search for and select a template file. It is advised to start the first drawing filename with a numeric suffix.

---

**NOTE** If you enter just a filename, the drawing files will be created and saved in the active project path.

---

## Export/Import spreadsheet data

### Update drawings from spreadsheet data

Use this to edit component tags, descriptions, catalog assignments, wire numbers, or PLC I/O descriptions from a spreadsheet and then have your edits update your drawings. Your spreadsheet/database edits can update existing or blank values on existing components, terminals, PLC I/O modules, and wire numbers but it cannot insert new items into the drawings.

- 1 Click Import/Export Data tab ► Export panel ► To Spreadsheet.



- 2 Select the data category to export.  
If you select General, information for the categories marked with an asterisk (\*) is extracted. Each category is saved to a separate sheet (spreadsheet format) or table (database format). The tab-delimited or comma-delimited formats are not available when writing out to multiple categories.
- 3 Click OK.
- 4 In the Data Export dialog box, specify to export the spreadsheet data for the current drawing or the entire project.
- 5 Specify the output format (Microsoft Excel, Access file, Tab-delimited ASCII, or Comma-delimited ASCII) and the location codes to extract, and click OK.

AutoCAD Electrical creates a file of the data pulled from your wiring diagram drawings.

- 6 Open this file in any spreadsheet or database program for view and edit.

**Caution:** If you selected a Tab or Comma-delimited ASCII format, import all fields as text. Some spreadsheet programs may try to convert some fields into numeric or scientific notation values. You may need to save the AutoCAD Electrical extracted data to a file with a .txt extension and then use the spreadsheet's import wizard to force all fields to be classified as text.

---

**NOTE** Do not edit the HDL and DWGNAME fields. These are used by the Update from Spreadsheet utility to link your edits back to the correct drawing and correct block insert on that drawing.

---

- 7 After editing, save the spreadsheet data back out to its original format.
- 8 (Optional) Before importing the spreadsheet data back into the drawing or project, add additional columns to the spreadsheet data. Label each column with a target ATTRIBUTE name.

During the import function, AutoCAD Electrical checks for these new attributes and updates them with data you entered into the spreadsheet.

- 9 Click Import/Export Data tab ► Import panel ► From Spreadsheet.



- 10 Select the spreadsheet and click Open.
- 11 In the Update Drawings per Spreadsheet Data dialog box, specify to import the spreadsheet data for the current drawing or the entire project.
- 12 Select any other import options and click OK. The data for the project or drawing automatically updates to match the edits on the spreadsheet.

All spreadsheet update changes are automatically logged, complete with time and date, in a text file saved to the AutoCAD Electrical user subdirectory.

If you edit the BLOCK field in the spreadsheet and assign a different block name, AutoCAD Electrical tries to find the new block during the update. If found, the old block is switched to the new one.

## Export to spreadsheet



Exports project data to a comma-delimited, Excel spreadsheet, or Access database file so you can examine and edit the data.

 **Ribbon:** Import/Export Data tab ► Export panel ► To Spreadsheet.



 **Toolbar:** Schematic Reports

 **Menu:** Projects ► Export to Spreadsheet ► Export to Spreadsheet

 **Command entry:** AEEXPORT2SS

You can edit component tags, descriptions, catalog assignments, wire numbers, and PLC I/O descriptions in the spreadsheet. Import the changes from the spreadsheet using Update from Spreadsheet. The spreadsheet can update existing components and wire numbers with your edits. If the block name is modified, it can swap one block for another. It cannot insert new items into drawings.

**Limitation:** Your spreadsheet edits can update existing or blank values on existing components, terminals, PLC I/O modules, and wire numbers but it cannot insert new items into the drawings. It only changes existing values.

## Component data export

This utility copies components to a comma-delimited, Excel XLS, or Access MDB file format for editing.

---

**NOTE** The [User-defined attributes list](#) on page 1 508 can be used to add fields to the spreadsheet if an attribute from a component is not exported by default.

---

 **Ribbon:** Import/Export Data tab ► Export panel ► To Spreadsheet.



 **Toolbar:** Schematic Reports

 **Menu:** Projects ► Export to Spreadsheet ► Export to Spreadsheet

 **Command entry:** AEEXPORT2SS

Select Component from the list.

### Data export for

Specifies to export the data for the active drawing or the entire project.

### Output format

Specifies the format for outputting the spreadsheet.

### Location Codes to extract

Extracts only the information for components with specific location values. After you pick Named Location, type the location code in the box or click List: Drawing or List: Project to select from a list of used location codes. You can also create a report from multiple location codes. AutoCAD Electrical automatically creates a comma-delimited list for the named location search.

### General data export

This utility copies all the data categories to a comma-delimited, Excel XLS, or Access MDB file format for editing.

 **Ribbon:** Import/Export Data tab ► Export panel ► To Spreadsheet.



 **Toolbar:** Schematic Reports

 **Menu:** Projects ► Export to Spreadsheet ► Export to Spreadsheet

 **Command entry:** AEEXPORT2SS

Select General from the list.

### Data export for

Specifies to export the data for the active drawing or the entire project.

### Output format

Specifies the format for outputting the spreadsheet.

### Location Codes to extract

Extracts only the information for components with specific location values. After you pick Named Location, type the location code in the box or click List: Drawing or List: Project to select from a list of used location codes. You

can also create a report from multiple location codes. AutoCAD Electrical automatically creates a comma-delimited list for the named location search.

## PLC I/O header information export

This utility copies PLC I/O header information to a comma-delimited, Excel XLS, or Access MDB file format for editing.

 **Ribbon:** Import/Export Data tab ► Export panel ► To Spreadsheet.



 **Toolbar:** Schematic Reports



 **Menu:** Projects ► Export to Spreadsheet ► Export to Spreadsheet

 **Command entry:** AEEXPORT2SS

Select PLC I/O header information from the list.

### Data export for

Specifies to export the data for the active drawing or the entire project.

### Output format

Specifies the format for outputting the spreadsheet.

### Location Codes to extract

Extracts only the information for components with specific location values. After you pick Named Location, type the location code in the box or click List: Drawing or List: Project to select from a list of used location codes. You can also create a report from multiple location codes. AutoCAD Electrical automatically creates a comma-delimited list for the named location search.

## PLC I/O connection export

This utility copies PLC I/O wire connections to a comma-delimited, Excel XLS, or Access MDB file format for editing.

 **Ribbon:** Import/Export Data tab ► Export panel ► To Spreadsheet.





-  **Toolbar:** Schematic Reports
-  **Menu:** Projects ► Export to Spreadsheet ► Export to Spreadsheet
-  **Command entry:** AEEXPORT2SS

Select PLC I/O wire connections from the list.

#### Data export for

Specifies to export the data for the active drawing or the entire project.

#### Output format

Specifies the format for outputting the spreadsheet.

#### Location Codes to extract

Extracts only the information for components with specific location values. After you pick Named Location, type the location code in the box or click List: Drawing or List: Project to select from a list of used location codes. You can also create a report from multiple location codes. AutoCAD Electrical automatically creates a comma-delimited list for the named location search.

### PLC I/O address/description export

This utility copies PLC I/O address/descriptions to a comma-delimited, Excel XLS, or Access MDB file format for editing.

-  **Ribbon:** Import/Export Data tab ► Export panel ► To Spreadsheet.



-  **Toolbar:** Schematic Reports
-  **Menu:** Projects ► Export to Spreadsheet ► Export to Spreadsheet
-  **Command entry:** AEEXPORT2SS

Select PLC I/O address/descriptions from the list.

#### Data export for

Specifies to export the data for the active drawing or the entire project.

### Output format

Specifies the format for outputting the spreadsheet.

### Location Codes to extract

Extracts only the information for components with specific location values. After you pick Named Location, type the location code in the box or click List: Drawing or List: Project to select from a list of used location codes. You can also create a report from multiple location codes. AutoCAD Electrical automatically creates a comma-delimited list for the named location search.

### Panel layout data export

This utility copies panel components to a comma-delimited, Excel XLS, or Access MDB file format for editing.

---

**NOTE** The [User-defined attributes list](#) on page 1508 can be used to add fields to the spreadsheet if an attribute from a component is not exported by default.

---

 **Ribbon:** Import/Export Data tab ► Export panel ► To Spreadsheet.



 **Toolbar:** Schematic Reports



 **Menu:** Projects ► Export to Spreadsheet ► Export to Spreadsheet

 **Command entry:** AEEXPORT2SS

Select Panel components from the list.

### Data export for

Specifies to export the data for the active drawing or the entire project.

### Output format

Specifies the format for outputting the spreadsheet.

### Location Codes to extract

Extracts only the information for components with specific location values. After you pick Named Location, type the location code in the box or click List: Drawing or List: Project to select from a list of used location codes. You

can also create a report from multiple location codes. AutoCAD Electrical automatically creates a comma-delimited list for the named location search.

## Panel terminals data export

This utility copies panel terminals to a comma-delimited, Excel XLS, or Access MDB file format for editing.

---

**NOTE** The [User-defined attributes list](#) on page 1508 can be used to add fields to the spreadsheet if an attribute from a component is not exported by default.

---

 **Ribbon:** Import/Export Data tab ► Export panel ► To Spreadsheet.



 **Toolbar:** Schematic Reports

 **Menu:** Projects ► Export to Spreadsheet ► Export to Spreadsheet

 **Command entry:** AEEXPORT2SS

Select Panel terminals from the list.

### Data export for

Specifies to export the data for the active drawing or the entire project.

### Output format

Specifies the format for outputting the spreadsheet.

### Location Codes to extract

Extracts only the information for components with specific location values. After you pick Named Location, type the location code in the box or click List: Drawing or List: Project to select from a list of used location codes. You can also create a report from multiple location codes. AutoCAD Electrical automatically creates a comma-delimited list for the named location search.

## Terminal data export

This utility copies terminals to a comma-delimited, Excel XLS, or Access MDB file format for editing.

---

**NOTE** The [User-defined attributes list](#) on page 1508 can be used to add fields to the spreadsheet if an attribute from a component is not exported by default.

---

 **Ribbon:** Import/Export Data tab ► Export panel ► To Spreadsheet.



 **Toolbar:** Schematic Reports



 **Menu:** Projects ► Export to Spreadsheet ► Export to Spreadsheet

 **Command entry:** AEEXPORT2SS

Select Terminals from the list.

### Data export for

Specifies to export the data for the active drawing or the entire project.

### Output format

Specifies the format for outputting the spreadsheet.

### Location Codes to extract

Extracts only the information for components with specific location values. After you pick Named Location, type the location code in the box or click List: Drawing or List: Project to select from a list of used location codes. You can also create a report from multiple location codes. AutoCAD Electrical automatically creates a comma-delimited list for the named location search.

## Update drawings per spreadsheet data

Imports data from an edited spreadsheet, and retags or updates components, wire numbers, terminal text, or PLC I/O.

 **Ribbon:** Import/Export Data tab ► Import panel ► From Spreadsheet.



 **Toolbar:** Schematic Reports



 **Menu:** Projects ► Export to Spreadsheet ► Update from Spreadsheet

 **Command entry:** AEIMPORTSS

Select the spreadsheet and click Open.

Export project data using Export to Spreadsheet. Edit the data and import changes to update the project drawings. The spreadsheet can update existing components and wire numbers with your edits. If the block name is modified, it can swap one block for another. It cannot insert new items into the drawings.

### **Process**

Specifies to import the spreadsheet data for the current drawing or the entire project.

### **Force spreadsheet new values to uppercase**

Forces all new spreadsheet values to be displayed in uppercase.

### **Flip any updated tag/wire number values to fixed**

Fixes all updated tag or wire number values. A fixed component tag does not update when the retag command is run. The tag name keeps its fixed value.

## **Create user-defined attributes**

You can define your own attributes onto AutoCAD Electrical block files and modify user-defined attributes using the AutoCAD Attribute Edit command or the Show/Edit Miscellaneous option on the AutoCAD Electrical Insert/Edit Component dialog box. The maximum allowable entries for reading or exporting any \*.wda file is 150.

Use the User Defined Attribute List tool to add these non-AutoCAD Electrical attributes in the AutoCAD Electrical report generators. Otherwise only those attributes defined inside of AutoCAD Electrical for each component category are processed in the project database and subsequent reports.

---

**NOTE** If the User Defined Attribute list contains AutoCAD Electrical attributes, they are added to the report if not already included.

---

The attributes listed in the User Defined Attribute list are also added to the fields exported in the Export to Spreadsheet feature for [Components](#) on page 1501, [Components \(parents only\)](#) on page 1501, [Terminals \(stand alone\)](#) on page 1506, [Panel components](#) on page 1505, or [Panel terminals](#) on page 1506.



---

**NOTE** You can edit the attribute text file (\*.wda) in Notepad; however, you must set the Encoding to Unicode in the Open and Save dialog boxes.

---

The Project Database Service (PDS) saves all non-AutoCAD Electrical-aware attributes from block files into the project for processing. The PDS maintains these database entries when the drawing file is saved and monitors them in real-time as if they are normal components in the project. Once the PDS successfully places the attribute values of all blocks from the drawing files into the AutoCAD Electrical project database, the report generator program is able to place the listed attribute values into the report generators if a \*.wda file is found with the appropriate name in any of the search paths and has the correct format.

---

**NOTE** The report format files (\*.set) support the user-defined attributes for automatic report generation. If a set file declares an attribute tag that is not found in the User Defined Attribute List, the column in the report is empty. The user-defined attributes display in the Change Report Format dialog boxes (on the Report Generator dialog box, click Change Report Format).

---

## Edit user-defined attribute list

Once you add an attribute to an AutoCAD Electrical block, you can edit the attribute using the Show/Edit Miscellaneous option in the Insert/Edit Component dialog box or using the Enhanced Attribute Editor tool accessed by double-clicking on an AutoCAD block in the drawing. Attributes can then be added to the user-defined attribute list for report generation.



- 1 Click Reports tab ► Miscellaneous panel ► User Attributes.
- 2 In the User Defined Attribute List dialog box, click inside the Attribute Tag column for Row 1. Click Pick.
- 3 Select the attribute from the drawing.  
The attribute displays in the Attribute Tag column in Row 1.
- 4 (Optional) Specify the column width, justification, and column title for the attribute for report generation purposes.  
Click in a cell to edit the cell or right-click in a cell to copy, cut, or paste contents from one cell into another. If left blank, default values are used.
- 5 Repeat for any additional attributes.
- 6 Click OK.

If this is the first time the grid content is being saved, the Save As dialog box displays. Enter the file name and click Save. This is generally <project\_name>.wda or default.wda.

---

**NOTE** Click Save As if an existing file needs to be saved in a different location or with a different name.

---

## User-defined attribute list

Creates or modifies a list of attributes to report.

 **Ribbon:** Reports tab ► Miscellaneous panel ► User Attributes.

 **Toolbar:** Schematic Reports

**Menu:** Projects ► Reports ► User Defined Attribute List

**Command entry:** AEUDA

Each report type has a set of predefined fields available to include in the report. The User Defined Attribute List provides additional attributes to add as available fields for all reports.

This tool creates an attribute text file (\*.wda) of user-defined attributes defined on AutoCAD Electrical block files. The User Defined Attribute List is used by report tools to determine which additional attributes are listed in a report. The list file name can be the same as the active project or named Default to be used by the entire system. The Default.wda file is saved in the base project folder, while the <project\_name>.wda file is saved in the same folder as the project definition file (\*.wdp).

---

**NOTE** Attributes can be added to existing block files using the Add Attribute tool or the AutoCAD ATTDEF command. Edit attributes using the Show/Edit Miscellaneous option in the Insert/Edit Component dialog box or using the Enhanced Attribute Editor tool accessed by double-clicking an AutoCAD Electrical block in the drawing.

---

Sort the list by clicking any of the column headers or move rows up or down in the list by highlighting multiple rows and dragging the selection on the sequence number list to the appropriate position.

<b>Attribute Tag</b>	<p>Edits and displays the list of attribute tags to be made available in the Report Generator. The attribute tags can be in any order in the list. Enter text, click in the cell to edit, or right-click in the cell to pick, copy, cut, or paste a value.</p> <hr/> <p><b>NOTE</b> An attribute tag is required and must be specified before you can edit any of the other fields in its row.</p> <hr/>
<b>Column Width</b>	<p>Edits and displays the column width for the attribute tag. Enter a number, click in the cell to edit, or right-click in the cell to copy or cut a value.</p> <hr/> <p><b>NOTE</b> If left blank, the column width is restricted to 24 characters.</p> <hr/>
<b>Justification</b>	<p>Edits and displays the justification of the attribute tag text. Click in the cell and select from Top Left, Top Center, Top Right, Middle Left, Middle Center, Middle Right, Bottom Left, Bottom Center, or Bottom Right justification. The justification definition can be modified inside the Change Report Format dialog box.</p> <hr/> <p><b>NOTE</b> If left blank, Top Left justification is used.</p> <hr/>
<b>Column Title</b>	<p>Edits and displays the column header title in the Report Generator dialog box. Enter text, click in the cell to edit, or right-click in the cell to copy, cut, or paste a value. The column title can be modified inside the Change Report Format dialog box.</p> <hr/> <p><b>NOTE</b> If left blank, the attribute tag is used as the column header.</p> <hr/>
<b>Pick</b>	<p>Selects an attribute from the drawing to use as the Attribute Tag.</p>
<b>Open</b>	<p>Browses for an existing User Defined Attribute List file for editing.</p>
<b>Save As</b>	<p>Creates a new User Defined Attribute List file with extension .wda.</p>

### Right-click options

<b>Pick</b>	Allows selection of an attribute from the drawing. This is available only for the Attribute Tag.
<b>Copy</b>	Copies the cell contents to paste in another.
<b>Cut</b>	Removes the cell contents to paste in another.
<b>Paste</b>	Places the copied or cut cell contents in a new cell.

---

**NOTE** You can also copy, cut, and paste entire row contents from one row to another (one at a time), however you cannot paste the row contents into a single cell.

---

## Export to Autodesk Inventor Professional

### Set up for export to Autodesk Inventor Professional Cable & Harness

You can export wire list information from AutoCAD Electrical and directly import it into Autodesk Inventor Professional Cable & Harness. In order to merge electrical and mechanical data, you must first create a one-to-one mapping from the electrical data to the mechanical assembly. Make sure the following are correctly set up before running the report.

#### Pin numbers on component symbols

The pin numbers on the component symbols in AutoCAD Electrical must correspond to the Pin Name property on the equivalent pin in Autodesk Inventor Professional Cable & Harness. Use the Pin Properties dialog box in Autodesk Inventor Professional Cable & Harness to change the pin name property. The pin number is the TERMxx attribute value on an AutoCAD Electrical component or terminal.

#### Component tags

Each component is defined with a unique Tag ID classified as the Component Tag. The component tags on each component in AutoCAD Electrical must correspond to the unique identifier or reference designator (RefDes property value) for the corresponding electrical part instance in the designated harness

assembly in the Cable & Harness application. Use the Part Properties dialog box in Autodesk Inventor Professional Cable & Harness to change the RefDes property.

You can define attributes on components in AutoCAD Electrical that can map to properties when exported to Autodesk Inventor Professional. These attributes can be component definition (catalog database) or component occurrence specific. Use the Edit Component tool to edit the occurrence of a component. Upon selection of a catalog number from the AutoCAD Electrical catalog database, component definition properties can be applied to the component occurrence and the information exported into the XML file.

---

**NOTE** When you apply additional parts to the component occurrence, their respective component definition properties can also be applied in the overall component occurrence. Up to ten additional part numbers can be applied to the occurrence of a component. Each of these catalog numbers can have their own set of component definition properties.

---

### **Wires**

In order to map wires from the schematic to the 3D design, each wire needs a persistent tag or number used to uniquely identify it within the design. The wire number in AutoCAD Electrical is used as the Wire ID property value in Cable & Harness. The cabling application needs a From/To list with a unique identifier to track inputs from multiple wire lists and to know when wires have moved or been updated on subsequent imports. The wires in the schematic must be fixed, mapped to a wire in the Cable & Harness Wire Library, and have distinct wires into the same pin.

---

**NOTE** The wire number must be unique for individual From and To connections and a wire network ladder style cannot be used.

---

You can define attributes and properties on a wire that can map to properties when exported to Autodesk Inventor Professional. These attributes can be wire definition (wire type) or wire occurrence specific. Use the Edit Wire Number tool to edit the wire number. Upon selection of a wire type from the Set/Edit Wire Type dialog box, wire definition properties can be applied to the wire layer occurrence and the information exported into the XML file.

### **Wire layers**

Not all nets in a schematic are physical wires; some are representative of other types of connections, such as those made by attaching a component to a bus bar. When attempts are made to map these nets in a harness assembly, the corresponding pins/parts are often not present. Only the nets that are to be

mapped into wires in 3D should be drawn with a layer identified as a wire for inclusion in the output report file for Autodesk Inventor Professional Cable & Harness. If a wire that is included in the custom report output file is not recognized as a library wire in the Cable & Harness Library during the Import Wire List process, the wire occurrence will not be imported.

The layers defined in AutoCAD Electrical must first be defined as valid wire layers. Each AutoCAD Electrical wire layer must then correspond to a valid library wire in the Cable & Harness Library. While the wire layer in AutoCAD Electrical is just a label or name, the Cable & Harness wire definition defines how the wire is displayed - including size (outer diameter and gauge) and color.

### **Cables**

When cables are used in the schematic, the name of the cable conductor (wire) layer defined in the drawing of AutoCAD Electrical must correspond to a valid cable definition in the Cable & Harness Library. The Wire Color/ID of each conductor in AutoCAD Electrical must correspond to a Conductor ID used in that cable definition in the Cable & Harness Library. This Wire Color/ID can be overwritten on each cable conductor occurrence by selecting Edit Component on a cable marker and making the change in the Insert / Edit Cable Marker dialog box. The Conductor list in the AutoCAD Electrical catalog can also be changed to reflect the same Conductor ID used in Cable & Harness.

The cable occurrence definition is made up of one parent symbol and multiple children symbols depending on the number of wires included. Upon selection of a catalog number from the AutoCAD Electrical catalog database, component definition properties can be applied to the component occurrence and the information exported into the XML file.

---

**NOTE** When you apply additional parts to the component occurrence, their respective component definition properties can also be applied in the overall component occurrence. Up to ten additional part numbers can be applied to the occurrence of a component. Each of these catalog numbers can have their own set of component definition properties.

---

### **Splices**

Each splice is defined with a Splice ID (component tag). The Splice ID in AutoCAD Electrical is used as the RefDes property value in Cable & Harness. Use the Edit Component tool to edit the splice component. Upon selection of a catalog number from the AutoCAD Electrical catalog database, splice definition properties can be applied to the component occurrence and the information exported into the XML file.

---

**NOTE** When you apply additional parts to the component occurrence, their respective splice definition properties can also be applied in the overall component occurrence. Up to ten additional part numbers can be applied to the occurrence of a component. Each of these catalog numbers can have their own set of component definition properties.

---

### **Branches and Ts in nets**

Branches and Ts in nets are not valid on nets imported into Cable & Harness. These types of representations map to multiple possible physical configurations. The exact physical intent of each wire must be depicted in the wiring diagram. Both non-physical and physical splices must be used so that each net that represents a wire has only two nodes: a From and a To. In AutoCAD Electrical, direct connections into a component must be created (no Ts) so that each physical wire has a definitive From component/pin and a To component/pin.

### **AutoCAD Electrical attributes mapped to Autodesk Inventor Professional properties**

There are four Autodesk Inventor Professional assembly entity types that get AutoCAD Electrical attributes: components, wires, cable, and splices.

<b>Attribute TAG</b>	<b>Attribute Type</b>	<b>Description</b>
<b>Component Properties</b>		
INST & LOC	Occurrence	Installation and Location code; associated to the component tag (RefDes)
TAG1 & TAG2	Occurrence	Component TAG - RefDes property name
DESC1- DESC3	Occurrence	Descriptions used to describe the component
CAT	Occurrence	Main AutoCAD Electrical catalog number - Part Number property name in Autodesk Inventor Professional
MFG	Occurrence	Manufacturer - Vendor of Part Number property name in Autodesk Inventor Professional

ASSYCODE	Occurrence	Assembly code for part - if part is a subset of an assembly
CAT01-10	Occurrence	Multiple BOM part numbers
MFG01-10	Occurrence	Multiple BOM Manufacturer associated to the Multiple BOM part numbers
ASSYCODE01-10	Occurrence	Multiple BOM Assembly codes associated to the Multiple BOM part numbers
RATING1-12	Occurrence	Rating information associated to the component definition
FAMILY	Definition	Family code definition - FAMILY attribute on AutoCAD Electrical block file
WDBLKNAM	Definition	Block name definition used for catalog lookup
<b>Wire Properties</b>		
WIRENO	Occurrence	Unique wire number ID - AutoCAD Electrical wire number
LAYER NAME	Occurrence	Wire layer name (AutoCAD Layer) - Wire Definition name in Autodesk Inventor Professional
Layer Name - Wire Properties Xrecords	Definition	Wire layer properties (Xrecords on AutoCAD layer) - Definition custom properties on the wire number in Autodesk Inventor Professional
WIRENO attributes WIRENO01-10	Occurrence	Wire attributes on wire number block file - Occurrence custom properties on the wire number in Autodesk Inventor Professional

#### **Cable ID Properties**



INST & LOC	Occurrence	Installation and Location code; associated to the component tag (RefDes)
TAG1 & TAG2	Occurrence	Component TAG - RefDes property name
RATING1	Occurrence	Cable conductor ID; AutoCAD Electrical Rating1 attribute - Cable Wire name in Autodesk Inventor Professional; add a numeric value along with the conductor color
DESC1 - DESC3	Occurrence	Descriptions used to describe the component
CAT	Occurrence	Main AutoCAD Electrical catalog number - Part Number property name in Autodesk Inventor Professional
MFG	Occurrence	Manufacturer - Vendor of Part Number property name in Autodesk Inventor Professional
ASSYCODE	Occurrence	Assembly code for part - if part is a subset of an assembly
CAT01-10	Occurrence	Multiple BOM part numbers
MFG01-10	Occurrence	Multiple BOM Manufacturer associated to the Multiple BOM part numbers
ASSYCODE01-10	Occurrence	Multiple BOM Assembly codes associated to the Multiple BOM part numbers
FAMILY	Definition	Family code definition - FAMILY attribute on AutoCAD Electrical block file
WDBLKNAM	Definition	Block name definition used for catalog lookup

#### Splice Properties

INST & LOC	Occurrence	Installation and Location code; associated to the component tag (RefDes)
TAG1	Occurrence	Component TAG - RefDes property name
DESC1- DESC3	Occurrence	Descriptions used to describe the component
CAT	Occurrence	Main AutoCAD Electrical catalog number - Part Number property name in Autodesk Inventor Professional
MFG	Occurrence	Manufacturer - Vendor of Part Number property name in Autodesk Inventor Professional
ASSYCODE	Occurrence	Assembly code for part - if part is a subset of an assembly
CAT01-10	Occurrence	Multiple BOM part numbers
MFG01-10	Occurrence	Multiple BOM Manufacturer associated to the Multiple BOM part numbers
ASSYCODE01-10	Occurrence	Multiple BOM Assembly codes associated to the Multiple BOM part numbers
RATING1-12	Occurrence	Rating information associated to the component definition
FAMILY	Definition	Family code definition - FAMILY attribute on AutoCAD Electrical block file
WDBLKNAM	Definition	Block name definition used for catalog lookup

## Output reports to Autodesk Inventor Professional Cable and Harness

Use this tool to export component, connector, wiring/cable, and splice data from your 2D connector drawing into an XML file that can then be imported into Autodesk Inventor Professional to aid in the generation of a cable and harness assembly.

---

**NOTE** You must first configure wire numbering to be "On per Wire Basis" for export and set up the appropriate variables before running the report.

---



- 1 Click Import/Export Data tab ► Export panel ► Inventor.
- 2 In the Autodesk Inventor Professional Export dialog box, specify whether to process the project or current drawing and click OK.
- 3 In the Autodesk Inventor Professional XML File Export dialog box, define the location and filename for the export file. By default file is saved with a .xml extension to:

**Windows XP:** C:\Documents and Settings\{username}\My Documents

**Windows Vista, Windows 7:** C:\Users\{username}\Documents

## Configure wire numbering for export

There are several steps to set up the wire numbering convention in AutoCAD Electrical for the import of data into Autodesk Inventor Professional Cable and Harness.

### Define wire layers

Layers defined in AutoCAD Electrical must be defined as valid wire layers. While the following steps do not create the layers on the drawings that need to be mapped into the Cable and Harness Library, they tell AutoCAD Electrical which layers are treated as valid wire types.

- 1 Click Schematic tab ► Edit Wires/Wire Numbers panel ► Modify Wire



Type drop-down ► Create/Edit Wire Type.

- 2 In the Create/Edit Wire Type dialog box, click Add Existing Layer to add the wire line layers in use in the schematic to the list to be recognized as layers by AutoCAD Electrical.
- 3 In the Layers for Line Wires dialog box, enter the layer name or pick a wire from the existing layer list.  
A wildcard used in the name selects a group of layers. For example, RED\_\* selects all layers that begin with "RED\_."
- 4 Click OK.
- 5 In the Create/Edit Wire Type dialog box, click OK.

---

**NOTE** You can also change layer properties using the Project Manager tool. In the Project Manager, right-click on the project name and select Properties. In the Drawing Format tab, Layers section, click Define.

---

### Set unique wire IDs

You need to assign each wire a unique wire ID or number before they can be imported into another application.



- 1 Click Project tab ► Project Tools panel ► Manager.
- 2 In the project listing, right-click the project name, and select Properties.
- 3 In the Project Properties dialog box, click the Wire Numbers tab.
- 4 In the Wire Number Options section, select On per Wire Basis.
- 5 Click OK.

### Fix wire numbering

You must fix the wire numbers so they stay the same for subsequent imports into Autodesk Inventor Professional Cable and Harness. Do this after the wire numbers have been assigned. Use any of the following procedures to fix wire numbers.

Automatic wire numbering:

- 1 Click Schematic tab ► Insert Wires/Wire Numbers panel ► Insert Wire



Numbers drop-down ► Wire Numbers.

- 2 In the Wire Tagging dialog box, select Insert as Fixed if it is not already selected.
- 3 Click Project-wide, Drawing-wide, or Pick Individual Wires depending on which method you want to use to update your wire numbers.

Manually inserting wire numbers:

- 1 Click Schematic tab ► Edit Wires/Wire Numbers panel ► Modify Wire



Numbers drop-down ► Edit Wire Number.

- 2 Click a wire that does not currently have a wire number assigned to it.
- 3 In the Insert wire number dialog box, select Make it Fixed to force the wire number to a fixed state.
- 4 Click OK.

Inserting wire numbers using project-wide utilities:



- 1 Click Project tab ► Project Tools panel ► Utilities.
- 2 In the Project-Wide Utilities dialog box, select Set all wire numbers to fixed.
- 3 Click OK. All wire numbers in the project are now flagged as fixed.

## Autodesk Inventor Professional export

Creates an XML file, and exports component and wiring data for Autodesk Inventor Professional into it.



 **Ribbon:** Import/Export Data tab ► Export panel ► Inventor.



 **Toolbar:** Schematic Reports

 **Menu:** Import/Export Data ► Export ► Autodesk Inventor Professional Export

 **Command entry:** AEAIPEXPORT

Extracts wire list information into an XML export file for use exclusively in Autodesk Inventor Professional Cable and Harness. Before you run the export, configure wire numbering to be On per Wire Basis for export and set up the appropriate variables.

Select to export the active drawing or the entire project.

The Autodesk Inventor Professional XML File Export dialog box then displays allowing you to define a location and filename for the export file. By default the file is saved with an .xml extension to:

- **Windows XP:** C:\Documents and Settings\{username}\My Documents
- **Windows Vista, Windows 7:** C:\Users\{username}\Documents

You can change the location and the last saved folder is persistent.

## Overview of panel layouts

Panel Layout tools create intelligent mechanical / panel layout drawings. Here are the key features:

- Layouts can be driven from information carried on the AutoCAD Electrical schematic wiring diagram drawings or they can be constructed independently of schematics.
- AutoCAD Electrical places no requirements on special naming or attribute requirements on mechanical footprint symbols. Vendor-supplied footprint symbols, in AutoCAD format, can be used as is with AutoCAD Electrical.
- Bi-directional update capabilities allow certain schematic wiring diagram edits to update the panel drawings automatically and vice versa.
- Wire number, wire color/gauge information, and connection sequencing data can be extracted directly from the schematics and annotated on to the panel footprint representations.
- AutoCAD Electrical extracts various reports from these smart panel layout drawings including panel BOM, panel component/item lists, nameplate reports, and schematic versus panel exception reports.

### Access panel layout tools

You access the AutoCAD Electrical panel layout command set from either the main Panel Layout option on the Electrical pull-down menu or from a panel-specific toolbar.

### Using the ribbon

Select the various panel layout commands from the [Panel tab](#) on page 60 on the ribbon in AutoCAD Electrical.

### Using the pull-down menu

Select the various panel layout commands from Panel Layout menu in AutoCAD Electrical.

### Using the toolbar

If the Panel Layout toolbar is not visible, you can turn it on by right-clicking on a toolbar and selecting ACE:Panel Layout.

### Using the mouse

Put your cursor over any panel component and click your right mouse button for a quick shortcut to AutoCAD Electrical commands. A component-specific menu displays at your cursor position.

Double-click the component itself to edit that component. The AutoCAD Electrical double-click feature is disabled if "selection" mode in AutoCAD is set to "Noun/Verb selection" (that is, system variable PICKFIRST is set to 1).

## Overview of footprint attributes/Xdata

AutoCAD Electrical does not have attribute or naming requirements for the mechanical footprint block symbols. As AutoCAD Electrical inserts a footprint symbol into the drawing, it copies various data to the footprint block such as component/device tag name, description, manufacturer code, and catalog number. It first looks for target attributes to copy the data to. If not found, AutoCAD Electrical simply inserts the schematic values as standard AutoCAD, nonvisible extended entity data (Xdata).

Some manufacturers provide free, to-scale mechanical libraries of their control components, all in AutoCAD format. Or you may have your own in-house footprints set up. In either case, since AutoCAD Electrical does not have naming or attribute requirements, these libraries can be used as is. When AutoCAD Electrical inserts such a block footprint symbol, it immediately becomes AutoCAD Electrical smart.

### Footprint block attribute/Xdata names

The following table is a list of footprint block data names that are inserted or read by AutoCAD Electrical. If the footprint block has an attribute with any



name listed here, AutoCAD Electrical uses that attribute to carry the specific piece of data. Otherwise, AutoCAD Electrical uses extended entity data with names based on the data names listed here but with a VIA\_WD\_ prefix (ex: "VIA\_WD\_DESC1").

FP	identifies block as a component footprint
FPT	identifies block as a terminal footprint
NP	identifies block as a nameplate
P_TAG1	panel component tag (used on component footprints and nameplates)
DESC1-3	description line 1 - 3 (60 char max)
P_ITEM	item/detail number
ITEM_FLAG	optional attribute with a value of 1 indicates the item number is fixed
MFG	manufacturer name (24 char max)
CAT	catalog number (60 char max)
ASSYCODE	optional assembly code
INST	installation code (24 char max)
LOC	location code (16 char max)
MOUNT	mount location code (24 char max)
GROUPWITH	group location code (24 char max)
WDBLKNAM	schematic symbol block name (used for catalog lookup)
RATING1-12	rating values (60 char max each)
P_TAGSTRIP	terminal strip ID (terminal footprints only)
TERM	terminal number (terminal footprints only)
WIRENO	wire number (terminal footprints only)

### Minimum attribute/Xdata requirements

The following tables are the minimum requirements for AutoCAD Electrical to recognize a block as a panel footprint, terminal, or nameplate.

**Component footprint** - block must carry a minimum of one of the following:

Xdata name	VIA_WD_FP
Attribute	FP (blank value)
Attribute	P_TAG1 (and no attribute NP present)

**Terminal footprint** - block must carry a minimum of one of the following:

Xdata name	VIA_WD_FPT
Attribute	FPT (blank value)

**Panel nameplate** - block must carry a minimum of one of the following:

Xdata name	VIA_WD_NP
Attribute	NP (blank value)

### Select Xdata to change to a block attribute

This tool converts any piece of invisible extended entity data (Xdata) into a visible attribute tied directly to the footprint block.

 **Ribbon:** Panel tab ► Other Tools panel ► Panel Configuration

drop-down ► Make Xdata Visible.



 **Toolbar:** Edit Footprint Component

 **Menu:** Panel Layout ► Make Xdata Visible

 **Command entry:** AESHOWXDATA

Select a footprint.

After you click Insert, the dialog box disappears. Click the location for the attribute. The attribute inserts, is linked to the footprint block, and the dialog

box redisplay. Repeat the process to convert other pieces of Xdata quickly into visible attributes.

<b>Xdata</b>	Displays all AutoCAD Electrical-related pieces of extended entity data (Xdata).
<b>Height</b>	Specifies the height for the attribute value.
<b>Justification</b>	Specifies the justification for the attribute value.
<b>Visibility</b>	Indicates whether the attribute is visible on the screen.
<b>Ratings</b>	Opens a sub-dialog for setting the values for rating attributes.
<b>Style</b>	Sets the width factor and text style for the attributes.

---

**NOTE** To add or modify the Xdata, use the AutoCAD Electrical Xdata Editor.

---

## Panel drawing configuration and defaults

Configuration settings are saved as attribute values on a nonvisible block named WD\_PNLM. If your current drawing does not have this block present when any AutoCAD Electrical panel layout command is invoked, AutoCAD Electrical pauses and asks you for permission to insert this block. It inserts at 0,0 but this location is not critical. The key point is that the nonvisible block must be present somewhere on the drawing.

---

**NOTE** You can make this block visible by typing ATTMODE at the AutoCAD command line prompt, changing the value from 1 to 2, and then typing REGEN.

---

### Panel drawing configuration and defaults

Sets panel footprint drawing defaults, such as footprint insertion scale, balloon setup, and layer assignments.

 **Ribbon:** Panel tab ► Other Tools panel ► Panel Configuration

drop-down ► Configuration.

 **Toolbar:** Panel Layout

 **Menu:** Panel Layout ► Panel Configuration

 **Command entry:** AEPANELCONFIG

Panel Configuration saves settings as attribute values on a non-visible block named WD\_PNLM. In any panel layout command, if this block is not present in the current drawing a message box displays asking permission to insert the block. The location of the block is not critical.

### **Item Numbering**

Specifies the number/letter to use as the first item number. AutoCAD Electrical manages item number, drawing-wide, or project-wide (over many drawings), so that the same number is always applied to identical components.

### **Balloon**

Opens a subdialog box for setting the type of balloon marker (circle, ellipse, polygon, text), marker size, margin, and text gap.

### **Footprint layers**

Opens the Panel Component Layers subdialog box for setting the panel component layers, non-text graphic layers, and nameplate layers. Panel footprint layering works in the same way AutoCAD Electrical schematic layering. When AutoCAD Electrical inserts a footprint, it is modified on the fly to match the layering scheme set up in this dialog box.

### **Wiring level defaults**

Sets the optional 3-digit wiring level codes. They are applied as defaults when codes are not defined on panel layout components or terminal strip representations. Preferred wire connection sequence follows this level and numeric-code-within-level hierarchy.

### **Default spacing for multiple inserts**

Specifies the x and y distance spacing for multiple footprint inserts.

### **Footprint insert**

Specifies the default insert scale for panel footprint symbols. Also specifies whether to insert the attribute template drawings and the scale to use.

You can set up to have visible attributes added to any footprint automatically at footprint insertion time. Using non-intelligent footprint representations

can insert with smart AutoCAD Electrical attributes added automatically, on the fly.

There are five attribute template drawings:

<b>wd_ptag_addattr_comp.dwg</b>	component footprints
<b>wd_ptag_addattr_trm.dwg</b>	terminal footprints
<b>wd_ptag_addattr_wtrm.dwg</b>	terminal with wire no. as terminal number
<b>wd_ptag_addattr_itmballoon.dwg</b>	balloons
<b>Wd_ptag_addattr_pnltermstrip.dwg</b>	terminal footprints (when inserted by Level/Sequencing tools)

If the appropriate attribute template exists, the following steps are performed when a panel footprint is inserted.

- 1 Find the center of the footprint by collecting and averaging the objects that make up the footprint.
- 2 Insert the attribute template at the calculated center of the footprint.
- 3 Make sure there are no duplicate attributes. If duplicate attributes are found, the attribute from the footprint is kept.
- 4 Reblock the added attributes with the inserted footprint.
- 5 Add the schematic data to the footprint. If the target attribute exists, the data is added as attribute data. If the target attribute does not exist, the data is added as invisible Xdata.

Uncheck the Enabled check box if you do not want AutoCAD Electrical to search for the attribute template drawing. If enabled, select a scale factor, 1.0 to insert as is, or select to scale to a specific text height.

#### **Panel wire connection report XYZ offset reference**

Specifies the x, y, or z-offset value for the mtext added next to a panel component when adding the wire connection information. Use the Setup button to define the default wire connection text format.

#### **Format: schematic layout wire connection annotation**

Defines the default wire connection text format.

 **Ribbon:** Panel tab ► Other Tools panel ► Panel Configuration

drop-down ► Configuration.



 **Toolbar:** Panel Layout

 **Menu:** Panel Layout ► Panel Configuration

 **Command entry:** AEPANELCONFIG

Click Panel wire connection report XYZ offset reference Setup.

After you add wire numbers to your schematics and extract this information, you are ready to annotate your panel footprint symbols with this information. The information is added to the drawing in two different ways:

- Build your panel footprint symbols with some target attributes that are used for the wire connection information.
- Mtext is automatically added next to a symbol if the target attributes are not found.

---

**NOTE** You can build two sets of panel footprint symbols, one set that does not carry the target attributes for wire information and a set that does. When you insert your panel symbols from the schematic extract, select Use Footprint tables to access the first set of symbols or Use Wiring diag tables to access the second set.

---

### Format

There are two format edit boxes on the dialog box. The "Full" format is used if AutoCAD Electrical does not find the target attributes and inserts MTEXT. The "Partial" format is used if AutoCAD Electrical finds the target attributes (described later). Each format uses parameters that are then replaced with the specific wire information. AutoCAD Electrical provides some pre-defined formats for you to select from the list box at the right. Or you can enter your own format using [replaceable parameters](#) on page 236.

Parameters must be separated by nonblank delimiters for AutoCAD Electrical to be able to re-extract wiring diagram information into reports. For example, "%T=%W %1 %G" is not acceptable because there is only a space between the

%W and %I and %G parameters. Acceptable formats include "%T=%W (%I) %G" or "%T=%W / %I (%G)" or "%T=%W (%I) %G".

---

**NOTE** You cannot use commas in the format. They signal multiple wire connection annotations onto a single wire connection attribute.

---

### **Additional options for the "To" component tag**

Additional options to include in the text.

<b>Add terminal pin as a suffix to tag</b>	Adds the terminal text as a suffix.
<b>Add terminal description to tag</b>	Adds any terminal description value as a suffix.
<b>Include installation prefix to IEC tag format</b>	Adds any installation value as a prefix.

### **View/Test**

Allows a preview or test of the report.

### **Suppress any duplicated annotation on each terminal**

Indicates to hide duplicated annotations so that they do not show on the report.

## **Relationship between schematic drawings and panel layouts**

### **Automatic schematic/panel update**

AutoCAD Electrical provides bi-directional updating between schematic components and the associated footprint blocks. The link is through the common tag identifier, for example, schematic relay coil, CR406, links to the panel layout footprint that carries a CR406 tag value.

Bi-directional updates follow these rules:

- Edits to a schematic parent update associated schematic child symbols, panel footprints, nameplates, and peer one-line symbols.

- Edits to a panel footprint update the associated schematic parent, child symbols, nameplates, and peer one-line symbols.
- Edits to a panel nameplate update the associated schematic parent, child symbols, panel footprints, and peer one-line symbols.
- Edits to a schematic child do not update the associated schematic parent, panel footprints, nameplates, or peer one-line symbols.
- Edits to a one-line terminal do not update any other terminal symbols.

## Schematic and panel symbol relationship

The schematic ladder diagram can be created first and the physical panel layout created from the schematic drawing.

Each symbol shown on the schematic ladder diagrams can map to a scaled, physical representation on the panel layout drawings. The physical layout drawing might be a control panel enclosure door layout. The door layout shows where to mount each component and can indicate the size of the hole in the sheet metal door for mounting.

---

**NOTE** One-line terminals are not mapped to panel layout terminals.

---

### Example

For example, pilot light components come in many styles, sizes, and ratings from dozens of vendors. On the schematic ladder diagrams, all pilot lights of a given type are identified by the same schematic symbol whether they are miniature pilot lights or a large, explosion projected pilot light. It is on the physical panel layouts where the pilot lights are shown as they actually look and in actual size (that is, the physical footprint representation).

Look at the three pilot light symbols shown in this schematic drawing.

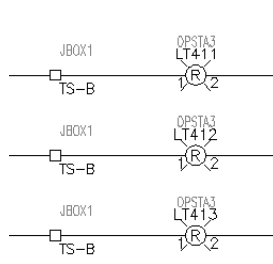



LT411 and LT413 are assigned an Allen-Bradley part number for a 30-mm pilot light (catalog part number 800H-PR16R). LT412 is given a part number for a smaller, 22.5-mm pilot light (catalog part number 800MR-P16RS). The manufacturer and catalog part number assignments are carried on invisible attributes MFG and CAT on each instance of the red pilot light symbol. All three symbols look the same on the schematic since they are the same AutoCAD block symbol. The difference is the assigned part number attribute values that each carries.

The three red pilot lights are represented as footprints in the panel layout as shown. Notice that LT412 (the 22.5-mm pilot light) appears smaller than the others.

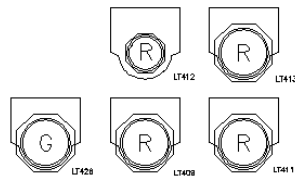

### Footprint Mapping

On the physical panel layout drawing, these pilot light symbols are inserted as footprint blocks using the [Insert Footprint \(Schematic List\)](#) on page 1536 tool.

AutoCAD Electrical knows which physical representation block symbol to use for each instance of the pilot light schematic symbol based on the manufacturer and part number assignments applied to the MFG/CAT attributes. The vendor name and part number are mapped to the correct footprint drawing (.dwg) file. This drawing is then inserted as a block on the panel layout drawing.

There are two key elements that make this work:

- Vendor footprint library (.dwg) files - two symbols from this library are shown here. They are for Allen-Bradley red pilot lights 30 mm and 22.5-mm styles respectively.



- [Footprint mapping file](#) on page 1592 (footprint\_lookup.mdb) - a table is assigned to each manufacturer.

## Footprint/Terminal Insertion

### Insert panel footprints from a schematic list

Let your project set of schematic wiring diagrams help drive the panel layout. Component catalog number information comes directly from manufacturer and catalog data carried on each electrical component. AutoCAD Electrical finds a match for the manufacturer and catalog number combination in the footprint look-up file to determine the correct footprint block to insert.

If you start with panel layouts before you create schematics, schematic pick list data is not available to automate footprint selection and annotation. An alternative is available. If you list your panel components in a spreadsheet and in a format that AutoCAD Electrical expects, this spreadsheet data can become your schematic pick list data for panel layout.

#### Component spreadsheet data format

The spreadsheet data must be in this order and have 28 columns of data and be saved in a "CSV comma delimited" text format. Most of the fields can be left blank:

1	TAG	Component tag id (ex: "PB101")
2	INST	Optional installation code
3	LOC	Optional location code
4	MOUNT	Optional mount code
5	GROUPWIDTH	Optional group code
6	MFG	Manufacturer code
7	CAT	Catalog number
8	ASM	Optional catalog assembly code

9	CNT	Optional count value
10	UM	Optional unit of measure
11-13	DESC1-DESC3	Three lines of description text
14	BLKNAM	Schematic block name (used to determine catalog lookup table name)
15-26	RATING1-12	Optional rating values
27	ITEM	Optional item number assignment
28		(blank)

### Panel terminals spreadsheet data format

The spreadsheet data for panel terminals must be in this order and have 30 columns of data and be saved in a "CSV comma delimited" text format. Most of the fields can be left blank:

1	TAGSTRIP	Terminal strip tag id (ex: "TB1")
2	INST	Optional installation code
3	LOC	Optional location code
4	MOUNT	Optional mount code
5	GROUPWIDTH	Optional group code
6	MFG	Manufacturer code
7	CAT	Catalog number
8	ASM	Optional catalog assembly code
9	CNT	Optional count value
10	UM	Optional unit of measure
11-13	DESC1-DESC3	Optional description text

14	BLOCK	Optional schematic block name (blank)
15-26	RATING1-12	Optional rating values
27	ITEM	Optional item number assignment
28	TERMNO	Terminal number
29		(blank)
30	WIRENO	Optional wire number tied to terminal

### Schematic spreadsheet data of previous project

If your new project is like a previous project, you can use the schematics of the previous project to create a component or terminal spreadsheet listing. It can then help drive the new panel layout of the project.

Open the previous project in AutoCAD Electrical. From the Panel Layout menu, select Insert Footprint (Schematic List) or Insert Terminal (Schematic List). On the selection dialog box, check the Save List to External File option and then extract from the project. AutoCAD Electrical creates a comma-delimited file of the schematic data. You can then display this data in spreadsheet format (open it in comma-delimited "CSV" format), edit, and then save back out. Now follow the procedure described for picking and inserting the panel component or terminal footprints from the spreadsheet driven pick list.

### Insert panel footprints from a schematic list

- 1 Insert a schematic symbol in a drawing. In the Insert/Edit Component dialog box, assign Component Tag, Manufacturer, and Catalog values and click OK.
- 2 Save the drawing and navigate to the drawing you want to add a panel footprint to.
- 3 Click Panel tab ► Insert Component Footprints panel ► Insert



Footprints drop-down ► Schematic List.

- 4 In the Schematic Components List ► Panel Layout Insert dialog box, select Project and click OK.

- 5 In the Select Drawings to Process dialog box, select the drawing that has the schematic symbol you inserted. Click Process, and then click OK.  
This extracts a list of all schematic devices found in the drawing and displays them in a dialog box for selection.
- 6 In the Schematic Components dialog box, select the schematic component you inserted and click Insert.
  - AutoCAD Electrical takes the manufacturer attribute value (MFG) and finds a table in the footprint\_lookup.mdb file with this name.
  - AutoCAD Electrical queries this specific vendor table using the catalog attribute value (CAT) of the selected entry and returns the block name from the matched record.
  - The Insert Footprint command starts and prompts for the insertion point for the footprint block.
- 7 Pick the insertion point and orientation.
  - The values of the schematic symbol are copied to the footprint representation.
  - The selected item is checked off the list in the Schematic Components dialog box (an "x" appears in the left-hand column) to track what has been inserted.
- 8 In the Panel Layout - Component Insert/Edit dialog box, click OK.
- 9 In the Schematic Components dialog box, click Close.

## Schematic components list -> panel layout insert

Inserts and annotates a panel footprint by referencing the schematic component list in the project.

 **Ribbon:** Panel tab ► Insert Component Footprints panel ► Insert

Footprints drop-down ► Schematic List.

 **Toolbar:** Component Footprint

 **Menu:** Panel Layout ► Insert Footprint (Schematic List)

 **Command entry:** AEFOOTPRINTSCH

Schematic diagrams can help drive the panel layout. Each electrical component carries manufacturer and catalog data with catalog number information. A matching manufacturer and catalog number combination in the footprint look-up file determines the correct footprint block to insert. The list of schematic components checks off the panel footprints you insert.

This tool provides error checking between the schematics and the panel layout drawings. The program looks at the selected components, both schematic and panel, to find a match in the project. For each schematic component selected, the routine tries to find a matching panel component based on tag, location, and installation information. If a match is found, then it further compares catalog information looking for any discrepancies. The program looks at each selected panel component looking for a matching schematic component in the same way.

---

**NOTE** One-line components are not extracted into the schematic component list and are not matched up with panel footprint representations.

---

If you start with panel layouts before you create schematics, schematic pick list data is not available to automate footprint selection and annotation. If you list your panel components in a spreadsheet and in a format that AutoCAD Electrical expects, this spreadsheet data can become your schematic pick list data for panel layout.

#### **Extract component list for**

Specifies to export the data for the active drawing or the entire project.

#### **Save list to external file**

Uses the schematics of a previous project to create a component or terminal spreadsheet listing. It can help drive the panel layout of a new project. AutoCAD Electrical creates a comma-delimited file of the schematic data. You can display this data in spreadsheet format (open it in comma-delimited "CSV" format), edit, and then save back out.

#### **Location Codes to extract**

Extracts only the information for components with specific location values. Once you pick Named Location, type the location code in the box or click List: Drawing or List: Project to select from a list of used location codes. You can also create a report from multiple location codes. AutoCAD Electrical automatically creates a comma-delimited list for the named location search.

#### **Schematic terminals list -> panel layout insert**

Inserts and annotates a panel terminal by referencing the schematic terminal list in the project.

 **Ribbon:** Panel tab ► Terminal Footprints panel ►  ► Insert

Terminals drop-down ► Insert Terminal (Schematic List).



 **Toolbar:** Terminal Footprint

 **Menu:** Panel Layout ► Insert Terminal (Schematic List)

 **Command entry:** AEPANELTERMINALSCH

This tool provides error checking between the schematic terminals and panel layout terminals. The program looks at the selected terminals, both schematic and panel, to find a match in the project. For each schematic terminal selected, the program tries to find a matching panel terminal based on a unique LINKTERM value or tag, location, installation, and terminal number information. If a match is found, then it further compares catalog information looking for any discrepancies. The program looks at each selected panel terminal looking for a matching schematic terminal in the same way.

---

**NOTE** One-line terminals are not extracted into the schematic terminal list and are not matched up with panel terminal footprint representations.

---

If you start with panel layouts before you create schematics, schematic pick list data is not available to automate footprint selection and annotation. If you list your panel components in a spreadsheet and in a format that AutoCAD Electrical expects, this spreadsheet data can become your schematic pick list data for panel layout.

### **Extract component list for**

Specifies to export the data for the active drawing or the entire project.

### **Save list to external file**

Uses previous schematics for the project to create a component or terminal spreadsheet listing. It can help drive the panel layout of the new project. AutoCAD Electrical creates a comma-delimited file of the schematic data. You can display this data in spreadsheet format (open it in comma-delimited "CSV" format), edit, and then save back out.

### Location Codes to extract

Extracts only the information for components with specific location values. Once you pick Named Location, type the location code in the box or click List: Drawing or List: Project to select from a list of used location codes. You can also create a report from multiple location codes. AutoCAD Electrical automatically creates a comma-delimited list for the named location search.

### Schematic components or terminals

AutoCAD Electrical processes the project drawing set. It presents a list of all parent components or terminals (plus any child components/terminals that carry non-blank MFG/CAT values) extracted from the schematic wiring diagrams of the project. First, you pick from this schematic list, and then place the equivalent footprint on the layout. AutoCAD Electrical determines the equivalent footprint block automatically through a manufacturer/catalog match pulled from the footprint look-up file.

---

**NOTE** One-line component and terminals are not included in the list.

---

#### Insert Footprint (Schematic List)

 **Ribbon:** Panel tab ► Insert Component Footprints panel ► Insert

Footprints drop-down ► Schematic List.

 **Toolbar:** Component Footprint

 **Menu:** Panel Layout ► Insert Footprint (Schematic List)

 **Command entry:** AEFOOTPRINTSCH

Select Project and click OK. Select the files to process and click OK.

#### Insert Terminal (Schematic List)

 **Ribbon:** Panel tab ► Terminal Footprints panel ►  ► Insert

Terminals drop-down ► Insert Terminal (Schematic List).





 **Toolbar:** Terminal Footprint

 **Menu:** Panel Layout ► Insert Terminal (Schematic List)

 **Command entry:** AEPANELTERMINALSCH

Select Project and click OK. Select the files to process and click OK.

### Sort List

Sorts the list of schematic footprints. You can specify four sorts to perform on the list.

### Reload

Reinitializes the display. Causes the dialog box to return to the Schematic components (or terminals) list panel layout insert dialog box.

### Mark Existing

Puts an "x" in the left-hand column position for any listed schematic component (or terminal) tag that already has its footprint inserted on the panel layout. There must be an exact match on Catalog and Manufacturer values between the two. Displays a "o" if the tags match but there is mismatch on Catalog and Manufacturer values between the two.

### Display

#### Show All/Hide Existing

Specifies to show all or hide the existing components or terminals.

#### Multiple Catalog [+]

Shows a full listing of the main catalog numbers plus the multiple catalog entries. Each multiple catalog entry displays in the list as a line entry, allowing you to insert each entry as a separate footprint.

### Catalog Check

Quickly performs a Bill of Material check and displays the result.

### Footprint Scale

Specifies the block insert scale. (1.0 = full)

**Rotate**

Specifies the block rotation angle. (blank = "ask")

**External Program**

Executes external user routine to retrieve footprint block name and/or catalog data. Requires WD\_XCAT reference in wd.env and a user AutoLISP file to manage the data send/receive with the external routine.

**Manual**

Specifies to pick the insertion point manually.

**Insert**

Finds and inserts footprint for highlighted component (or terminal). It is based upon a match between the catalog part number of the schematic symbol and an entry in a footprint lookup file. If no match is found you are prompted to draw the footprint manually, add an entry in the lookup file, or select an existing footprint drawing file.

**Use Footprint tables**

Accesses the standard footprint look-up table that matches the MFG code of the device. This table is set up to insert a full mechanical representation of the device.

**Use Wiring diagram tables**

Accesses an alternate table in the footprint look-up table. This table matches the MFG code but attaches an "\_WD" suffix. The tables with the "\_WD" suffix are set up to insert a symbol that carries the wire connection attributes.

**Convert Existing**

Inserts data of a selected entry on an existing dumb block insert. It instantly converts the block to a smart AutoCAD Electrical footprint.

**Pick File**

Specifies to pick a file for the insert. Select an existing AutoCAD Electrical Schematic extracted component (or terminal) list file or extract a fresh copy of schematic component (or terminal) data from the database of the current project.

**Spacing for component or footprint insertion**

Run any of the component, footprint, or terminal insertion from list commands (such as [Insert Component \(Panel List\)](#) on page 790). Select the drawings to process and click OK. Select multiple components or terminals to insert and click Insert.

The components display in the list box in the order they are inserted. To modify the order, select an item from the list, then select Move Up or Move Down in the list.

<b>Prompt for each location</b>	Specifies the location for each component or terminal using the Insert dialog box.
<b>Fence Insertion</b>	(for component insertion only) Specifies the location for all the components. Specify the insertion points on the drawing and right-click. The Insert/Edit dialog box displays. Once you click OK on the Insert/Edit dialog box, the component inserts on the drawing.
<b>Use uniform spacing</b>	Specifies the location for the first component (or terminal). The values in the X-distance and Y-distance boxes are used to calculate the insertion coordinates for the remaining components (or terminals). <hr/> <b>NOTE</b> You can set the default values for the X-distance and Y-distance in the Panel Configuration dialog box. <hr/>
<b>Suppress edit dialog and prompts</b>	(for footprint insertion only) Suppresses the edit dialog box that normally appears each time a component (or terminal) is inserted. The Panel Insert/Edit dialog box displays after each insert if this option is not selected.
<b>Move Up</b>	Moves the selected component or terminal up one spot in the list.
<b>Move Down</b>	Moves the selected component or terminal down one spot in the list.
<b>Reverse</b>	Rearranges the list of terminals in descending order.
<b>Re-sort</b>	Sorts the list of terminals in ascending order.

## Insert panel footprints using vendor menus

Pick the item from a vendor icon menu that is preset with specific catalog number data and footprint block names. Choosing from this menu supplies AutoCAD Electrical with the manufacturer and catalog information and the footprint block name, bypassing any look-up.

It can save time if you frequently use the same vendor and panel components. You can apply this method to create client-specific menus making it easier to use the vendor or components that each client prefers.

### Insert panel footprints using vendor menus

A vendor icon menu is preset with specific catalog number data and footprint block names. Choosing from this menu supplies the manufacturer and catalog information and the footprint block name, bypassing any look-up.

- 1 Click Panel tab ► Insert Component Footprint panel ► Insert Footprints



drop-down ► Manufacturer Menu .

- 2 In the Vendor Menu Selection dialog box, select the vendor menu to use and click OK. You can select one from the list or click Browse to search for a vendor (.pnl) menu file.

---

**NOTE** This dialog box is also available by clicking Vendor Menu Select on the Vendor Panel Footprint dialog box after a vendor is first selected.

---

- 3 In the Vendor Panel Footprint dialog box, select the component to insert from the Symbol Preview window and click OK.  
Clicking an icon inserts the footprint into the active drawing as defined by the command in the .pnl file.
- 4 Select the insertion point on the screen.

### Vendor menu selection

 **Ribbon:** Panel tab ► Insert Component Footprints panel ► Insert



Footprints drop-down ► Manufacturer Menu.



 **Toolbar:** Component Footprint

 **Menu:** Panel Layout ► Insert Footprint (Manufacturer Menu)

 **Command entry:** AEFOOTPRINTMFG

---

**NOTE** This dialog box is also available by clicking Vendor Menu Select on the Vendor Panel Footprint dialog box after a vendor is first selected.

---

The vendor icon menu files that are found in AutoCAD Electrical are listed in the dialog box.

## Vendor panel footprint

 **Ribbon:** Panel tab ► Insert Component Footprints panel ► Insert



Footprints drop-down ► Manufacturer Menu.



 **Toolbar:** Component Footprint

 **Menu:** Panel Layout ► Insert Footprint (Manufacturer Menu)

 **Command entry:** AEFOOTPRINTMFG

Select the vendor menu to use and click OK.

Clicking an icon inserts the footprint into the active drawing as defined by the command in the .pnl file.

### Tabs

- Menu: Changes the visibility of the Menu tree view.
- Up one level: Displays the menu that is one level before the current menu in the Menu tree view. It is unavailable if the main menu is selected in the Menu tree view.
- Views: Changes the view display for the Symbol Preview window and Recently Used window. The current view option is indicated with a check mark. Options include: Icon with text, Icon only or List view.

### Menu

The tree structure is created by reading the icon menu file (\*.dat). The tree structure is based on the arrangement order of submenus defined in the .dat file.

<b>Symbol Preview window</b>	Displays the symbol images corresponding to the menu or the submenu selected in the Menu section. Clicking on the icon inserts the footprint into the active drawing as defined by the command in the .pnl file.
<b>Recently Used</b>	Displays the last components inserted during the current editing session; the most recently used icon displays in the top. This list box follows the view options setting in the symbol preview window (icon, icon with text or list view). The total number of icons displayed depends on the value specified in the Display edit box.
<b>Display</b>	Specifies the number of icons to display in the Recently Used list box. Enter integer numbers only; the default value is 10.
<b>No edit dialog box</b>	Turns off the Insert/Edit Component dialog box when inserting symbols onto the drawing. To add component detail later, click the Edit Component tool, and select the component to edit.
<b>No tag</b>	Inserts the component, untagged (that is, without assigning a unique Component Tag). The untagged value that displays is the TAG1/TAG2 default value of the component. To add component detail later, click the Edit Component tool, and select the component to edit.
<b>Always display previously used menu</b>	Indicates to display the previously used menu each time you open the Insert Component dialog box. For example, if you insert a push button from the Push Buttons menu, the next time you open the Insert Component dialog box the Push Button menu displays by default.
<b>Scale</b>	Specifies the component block insertion scale. This defaults to the value set in the Panel Drawing Configuration dialog box. Once set, this value is remembered until reset or until the drawing editing session ends. There are separate scale factors for schematic and panel components.
<b>Vendor Menu Select</b>	Displays the Vendor Menu Selection dialog box.
<b>Type it</b>	Manually type in the component block to insert.
<b>Browse</b>	Browses to and selects the component to insert.

## Right-click menus

### Options for the Menu tree structure view

Right-click the main menu or submenu in the Menu tree structure view to display the following options:

- **Expand/Collapse:** Toggles the visibility of the folders.
- **Properties:** Opens a Properties dialog box to modify the existing menu or submenu properties like the menu name, image, or submenu title. Use the Icon Menu Wizard to change any menu properties.

### Options for the Symbol Preview window

Right-click an icon or in empty space in the Symbol Preview window to display the following options:

- **View:** Changes the view display for the Symbol Preview window and Recently Used window. The current view option is indicated with a check mark. Options include: Icon with text, Icon only or List view.
- **Properties:** (available for icons only) Opens a Properties dialog box to modify the existing symbol icon properties like the icon name/image/block names and so on. Use the Icon Menu Wizard to change any icon properties.

## Insert panel footprints using icon menu

Pick a general component category from a generic icon menu (such as pilot lights). Once a component is selected, choose from the options available to insert the footprint.

- **Choice A** - make catalog assignment for automatic footprint selection. AutoCAD Electrical finds a match for the manufacturer and catalog number combination in the footprint look-up file to determine the correct footprint block to insert.
- **Choice B** - manual footprint selection or creation.
- **Choice C** - in cases where a manufacturer and catalog is given but is not in a lookup file, AutoCAD Electrical enables this option allowing you to add an entry in the footprint look-up database file.

## Insert panel footprints using icon menu

- 1 Click Panel tab ► Insert Component Footprints panel ► Insert



Footprints drop-down ► Icon Menu.

- 2 In the Insert Footprint dialog box, select the component to insert from the Symbol Preview window and click OK.
- 3 On the [Footprint](#) on page 1552 dialog box, choose one of the following:
  - **Choice A** - make catalog assignment for automatic footprint selection.
  - **Choice B** - manual footprint selection or creation.
  - **Choice C** - in cases where a manufacturer and catalog is given but is not in a lookup file, AutoCAD Electrical enables this option allowing you to add an entry in the footprint look-up database file.
- 4 Insert or draw the footprint.
- 5 Enter values in the Panel Layout - Component Insert/Edit dialog box.
- 6 Click OK.

## Insert footprint

Inserts a panel footprint you select from the icon menu.

-  **Ribbon:** Panel tab ► Insert Component Footprints panel ► Insert



Footprints drop-down ► Icon Menu.



-  **Toolbar:** Panel Layout

-  **Menu:** Panel Layout ► Insert Footprint (Icon Menu)

-  **Command entry:** AEFOOTPRINT

You can insert smart footprint outlines of electrical components and devices onto layout drawings. You pick the insertion point and orientation for the footprint. Assign values on the footprint such as tag, catalog assignment, location, installation, descriptions, ratings, and miscellaneous values.



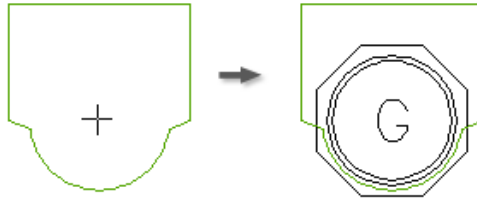

Select an icon picture or the component type from the Menu tree structure. The main menu in the tree structure is displayed as the menu heading just above the menu tree structure.

This icon menu can be modified, expanded, or replaced with your own custom menu. You can change the default icon menu using the Library and Icon Menu Paths section of the [Project properties: project settings tab](#) on page 204. Use the Icon Menu Wizard to modify the menu easily. The default icon menu can also be redefined in "wd.env". Add entry "WD\_MENU" for schematic icon menu and "WD\_PMENU" for panel layout icon menu.

#### Tabs

- Menu: Changes the visibility of the Menu tree view.
- Up one level: Displays the menu that is one level before the current menu in the Menu tree view. It is unavailable if the main menu is selected in the Menu tree view.
- Views: Changes the view display for the Symbol Preview window and Recently Used window. The current view option is indicated with a check mark. Options include: Icon with text, Icon only or List view.

#### Menu

The tree structure is created by reading the icon menu file (.dat). The tree structure is based on the arrangement order of submenus defined in the .dat file.

---

**NOTE** If the program cannot find any of the icon menu files listed in the .wdp, an alert dialog box appears.

---

#### Symbol Preview window

Displays the symbol images corresponding to the menu or the submenu selected in the Menu section. Clicking on the icon performs one of the following functions based on the icon properties as defined by the .dat file:

- Executes a command
- Displays a submenu

---

**NOTE** When you move the cursor over an icon, the icon name and block/circuit/command name display as tooltip information.

---

<b>Recently Used</b>	Displays the last components inserted during the current editing session; the most recently used icon displays in the top. The list box follows the view options setting in the symbol preview window (icon, icon with text or list view) and the total number of icons displayed depends on the value specified in the Display edit box.
<b>Display</b>	Specifies the number of icons to display in the Recently Used list box. Enter integer numbers only; the default value is 10.
<b>No edit dialog box</b>	Turns off the Insert/Edit Component dialog box when inserting symbols onto the drawing. To add component detail later, click the Edit Component tool, and select the component to edit.
<b>No tag</b>	Inserts the component, untagged (example: without assigning a unique Component Tag). The untagged value that displays is the TAG1/TAG2 default value of the component. To add component detail later, click the Edit Component tool, and select the component to edit.
<b>Always display previously used menu</b>	Indicates to display the previously used menu each time you open the Insert Component dialog box. For example, if you insert a push button from the Push Buttons menu, the next time you open the Insert Component dialog box the Push Button menu displays by default.
<b>Scale schematic</b>	Specifies the component block insertion scale. This defaults to the value set in the Panel Drawing Configuration dialog box. Once set, this value is remembered until reset or until the drawing editing session ends.
<b>Scale panel</b>	Specifies the footprint insertion scale. This defaults to the value set in the Panel Drawing Configuration dialog box. Once set, this value is remembered until reset or until the drawing editing session ends.

<b>Type it</b>	Manually type in the component block to insert.
<b>Browse</b>	Browses to and selects the component to insert.

### Right-click menus

#### Options for the Menu tree structure view

Right-click the main menu or submenu in the Menu tree structure view to display the following options:

- Expand/Collapse: Toggles the visibility of the menus.
- Properties: Opens a Properties dialog box to view the existing menu or submenu properties like the menu name, image, or submenu title. Use the Icon Menu Wizard to change any menu properties.

#### Options for the Symbol Preview window

Right-click an icon or in empty space in the Symbol Preview window to display the following options:

- View: Changes the view display for the Symbol Preview window and Recently Used window. The current view option is indicated with a check mark. Options include: Icon with text, Icon only or List view.
- Properties: (available for icons only) Opens a Properties dialog box to view the existing symbol icon properties like the icon name/image/block names and so on. Use the Icon Menu Wizard to change any icon properties.

## Insert panel footprints manually

Select to use a generic marker only, draw shapes, select a similar footprint, choose from a file dialog box, or pick on an existing block on the current drawing to convert it to AutoCAD Electrical on the fly.

### Insert panel footprints manually

- 1 Click Panel tab ► Insert Component Footprints panel ► Insert



Footprints drop-down ► Manual.

- 2 In the Insert Component Footprint -- Manual dialog box, select:
  - **Use generic marker only** - Insert a block to annotate with the tag, description text, and so on, of the component.
  - **Draw shapes** - draw a rectangle, circle, or octagon to represent the component.
  - **Pick "just like" footprint** - Select a block from the drawing.
  - **Browse** - pick a block from a list of files on disk.
  - **Pick** - pick a non-AutoCAD Electrical block on the drawing to change into a smart AutoCAD Electrical block.
- 3 Insert or draw the footprint.
- 4 Enter values in the Panel Layout - Component Insert/Edit dialog box.
- 5 Click OK.

## Footprint

Some schematic components may not carry manufacturer/catalog information or have a part number assigned that is not listed in the footprint lookup file. In such a case, AutoCAD Electrical cannot determine which footprint block to use, so you must select to make catalog assignments, select or create a footprint, or create a lookup entry on the fly.

### Insert Footprint (Icon Menu)

 **Ribbon:** Panel tab ► Insert Component Footprints panel ► Insert

Footprints drop-down ► Icon Menu.

 **Toolbar:** Panel Layout

 **Menu:** Panel Layout ► Insert Footprint (Icon Menu)

 **Command entry:** AEFOOTPRINT

Select the footprint to insert.

### Choice A - make catalog assignment for automatic footprint selection

Enter catalog information, or if there is not a catalog assignment use the catalog lookup to find and select catalog information. An attempt is made to

find a match in the footprint lookup of the manufacturer or the \_PNLMISC miscellaneous lookup file.

### **Choice B - manual footprint selection or creation**

Skips the catalog assignment. Select from the available options to insert a footprint.

<b>Use generic marker only</b>	Inserts a block with the tag, description text, and so on, of the component.
<b>Draw shapes</b>	Draws a rectangle, circle, or octagon to represent the component. Text and hidden information inserted when drawn.
<b>Pick "just like" footprint</b>	Select a block from the drawing.
<b>Browse</b>	Pick a block from a list of .DWG files on disk.
<b>Pick</b>	Pick a non-AutoCAD Electrical block on the drawing to be instantly changed into a smart AutoCAD Electrical block.
<b>ABECAD</b>	Pick your own ABECAD install to link to.

### **Choice C - add entry to footprint database**

A footprint lookup database table matches MFG/CAT part number combinations with their appropriate footprint blocks. In cases where a MFG/CAT number is given but is not in a lookup file, AutoCAD Electrical enables this option.

There are two categories of panel footprint lookup files: manufacturer and miscellaneous.

<b>Add Entry to Manufacturer</b>	Adds a new entry to the manufacturer-specific footprint lookup table and matches it with an existing footprint block or drawing file. It has the same name as the manufacturer name of the component.
<b>Add Entry to Miscellaneous</b>	Adds a new entry to a miscellaneous (catch all) footprint lookup table called "_PNLMISC". It adds the MFG/CAT combination to the footprint lookup table and matches it with an existing footprint block

or library symbol. If the lookup table does not exist, it is created.

### Insert Footprint (Manual)

 **Ribbon:** Panel tab ► Insert Component Footprints panel ► Insert

Footprints drop-down ► Manual.



 **Toolbar:** Component Footprint

 **Menu:** Panel Layout ► Insert Footprint (Manual)

 **Command entry:** AEFOOTPRINTMAN

Skips the catalog assignment. Select to draw a simple footprint representation of the selected device, browse for a footprint block file, pick on an existing block on the current drawing to convert it to AutoCAD Electrical-smart on the fly, or invoke an external program to find and insert a footprint representation of a given catalog number.

<b>Use generic marker only</b>	Inserts a block with the tag, description text, and so on, of the component.
<b>Draw shapes</b>	Draws a rectangle, circle, or octagon to represent the component. Text and hidden information inserted when drawn.
<b>Pick "just like" footprint</b>	Select a block from the drawing.
<b>Browse</b>	Pick a block from a list of .DWG files on disk.
<b>Pick</b>	Pick a non-AutoCAD Electrical block on the drawing to be instantly changed into a smart AutoCAD Electrical block.
<b>ABECAD</b>	Pick your own ABECAD install to link to.

## Insert panel footprints from a catalog list

Inserts panel symbols by choosing a catalog number or a component description from a user-defined pick list. The data displayed in this pick list is stored in a database in generic Access format. The file name is *wd\_picklist.mdb* and can be edited with Access or from Add/Edit/Delete along the bottom of the dialog box of the pick list.

### Insert panel footprints from a catalog list

Insert a panel symbol by choosing a catalog number or a component description from a user-defined pick list. The data displayed in this pick list is stored in a database in generic Access format. The file name is *wd\_picklist.mdb* and can be edited with Access or from Add/Edit/Delete along the bottom of the dialog box of the pick list.

- 1 Click Panel tab ► Insert Component Footprints panel ► Insert



Footprints drop-down ► Catalog List.

- 2 In the Panel footprint: Select and Insert by or Description Pick dialog box, select a component.
- 3 Click OK.
- 4 Select the insertion point and orientation.
- 5 Enter values in the Panel Layout - Component Insert/Edit dialog box.
- 6 Click OK.

### Schematic component or panel footprint

Inserts schematic or panel symbols by choosing a catalog number or a component description from a user-defined pick list. The data displayed in this pick list is stored in a database in generic Access format. The file name is *wd\_picklist.mdb* and can be edited with Access or from Add/Edit/Delete along the bottom of the dialog box for the pick list. The AutoCAD Electrical normal search path sequence is used to locate this file.

### Insert Component (Catalog List)

 **Ribbon:** Schematic tab ► Insert Components panel ► Insert Components

drop-down ► Catalog List.



 **Toolbar:** Insert Component

 **Menu:** Components ► Insert Component (Lists) ► Insert Component (Catalog List)

 **Command entry:** AECOMPONENTCAT

### Insert Footprint (Catalog List)

 **Ribbon:** Panel tab ► Insert Component Footprints panel ► Insert

Footprints drop-down ► Catalog List.



 **Toolbar:** Insert Footprint (Lists)

 **Menu:** Panel Layout ► Insert Footprint (Lists) ► Insert Footprint (Catalog List)

 **Command entry:** AEFOOTPRINTCAT

Both schematic and panel layout symbols can be included in the pick list database. Only schematic or panel entries are displayed at a time depending on whether the routine is called from the AutoCAD Electrical or Panel Layout toolbar.

<b>Sort by</b>	Specifies how to sort the record list. You can sort by description, catalog number, or manufacturer code.
<b>Add</b>	Opens a dialog box for creating a record. If the footprint block is not in an AutoCAD or an AutoCAD Electrical search path, include the part of the path to append to one of these search paths (or you can enter the full path). If the new record is like an existing record, highlight the existing record before you click Add.
<b>Edit</b>	Opens a dialog box for editing a record. Highlight the record and click Edit. Modify the record in the displayed dialog box.



Delete

Removes an existing record.

## Insert footprints from an equipment list

This tool lists data extracted from your equipment list, finds the appropriate panel symbol by querying the footprint\_lookup.mdb, and inserts the panel footprint at your pick point. Each line or record in the equipment list represents a single entry into the Panel Equipment in {file name} dialog box for schematic component selection. The quantity for a selected catalog number is not supported.

### Insert footprints from an equipment list

- 1 Click Panel tab ► Insert Component Footprints panel ► Insert



Footprints drop-down ► Equipment List.

- 2 Browse to and select your equipment list.
- 3 Select the sheet name if prompted.
- 4 Define the settings for the equipment list on the Settings dialog box. This includes assigning column numbers to data categories, such as Manufacturer, Catalog, and Installation.
- 5 Click OK on the Settings dialog box. The equipment is displayed in the Panel equipment in {file name} dialog box.
- 6 Select an item and click Insert.
  - AutoCAD Electrical takes the manufacturer attribute value (MFG) and finds a table in the footprint\_lookup.mdb file with this name.
  - AutoCAD Electrical queries this specific vendor table using the catalog attribute value (CAT) of the selected entry and returns the block name from the matched record.
  - The Insert Footprint command starts and prompts for the insertion point for the footprint block.
- 7 Pick the insertion point and orientation.
  - The values from the equipment list are copied to the footprint representation.

- 8 In the Panel Layout - Component Insert/Edit dialog box, enter additional component values and click OK.
- 9 In the Panel equipment in {file name} dialog box, click Close.

## Panel equipment in

You can select to insert a single panel footprint or multiple footprints from the equipment list.

 **Ribbon:** Panel tab ► Insert Component Footprints panel ► Insert

Footprints drop-down ► Equipment List.

 **Toolbar:** Insert Footprints (Lists)

 **Menu:** Panel Layout ► Insert Footprint (Lists) ► Insert Footprint (Equipment List)

 **Command entry:** AEFOOTPRINTEQ

Select the spreadsheet file to use and click Open. Specify to use the default settings or previously saved settings and click OK.

### Sort List

Sorts the list of components. You can specify four sorts to perform on the list.

### Catalog Check

Performs a Bill of Material check and displays the result. Enabled if the selected panel component contains catalog data.

### Footprint scale

Specifies the block insert scale. (1.0 = full)

### Rotate

Specifies the block rotation angle. (blank = "ask")

### **External Program**

Executes an external user routine to retrieve the footprint block name and catalog data. Requires the WD\_XCAT reference in the wd.env and a user AutoLISP file to manage the data send/receive with the external routine.

### **Manual**

Specifies to pick the panel footprint manually. The Panel Component dialog box displays, so you can define the footprint to use.

### **Insert**

Finds and inserts footprint for the highlighted component. It is based on a match between the catalog part number of the footprint symbol and an entry in a schematic lookup file. If 0 matches are found, you are prompted to draw the footprint manually, add an entry in the lookup file, or select an existing footprint drawing file. If multiple components are selected in the list, the Spacing for Footprint Insertion dialog box displays. Define how to insert the first component of each device.

#### **Use Footprint tables**

Accesses the standard footprint lookup table that matches the MFG code of the device. This table is set up to insert a full mechanical representation of the device.

#### **Use Wiring diagram tables**

Accesses an alternate table in the footprint lookup table. This table matches the MFG code but attaches an "\_WD" suffix. The tables with the "\_WD" suffix are set up to insert a symbol that carries the wire connection attributes.

### **Convert Existing**

Inserts selected data on an existing "dumb" block insert. It converts the block to a smart AutoCAD Electrical footprint.

### **Pick File**

Allows you to pick a file for the insert. Select an existing AutoCAD Electrical extracted panel component list file or extract a fresh copy of panel component data from the current database of the project.

### **Settings**

This spreadsheet organizes the selected user-created equipment list and presents the list in a pick list. As you pick an item from the pick list, the appropriate schematic symbol is found and inserted in the drawing at your pick point.

Your equipment list can be an AutoCAD Electrical-generated Component report, or it can be a list of motors giving horsepower and starter type along with motor ID and descriptions.

---

**NOTE** You can open a comma-delimited file, Excel spreadsheet, or Access database file for input.

---

### Insert Component (Equipment List)

 **Ribbon:** Schematic tab ► Insert Components panel ► Insert Components

drop-down ► Equipment List.

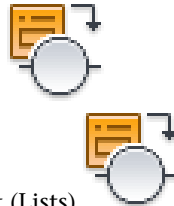

 **Toolbar:** Insert Component (Lists)

 **Menu:** Components ► Insert Component (Lists) ► Insert Component (Equipment List)

 **Command entry:** AECOMPONENTEQ

Select the spreadsheet file to use and click Open. Click the table to edit and click OK.

### Insert Footprint (Equipment List)

 **Ribbon:** Panel tab ► Insert Component Footprints panel ► Insert

Footprints drop-down ► Equipment List.



 **Toolbar:** Insert Footprint (Lists)

 **Menu:** Panel Layout ► Insert Footprint (Lists) ► Insert Footprint (Equipment List)

 **Command entry:** AEFOOTPRINTEQ

Select the spreadsheet file to use and click Open. Click the table to edit and click OK.

**Default settings** Uses the default settings for managing equipment lists.

**Read settings** Reads and uses the settings for a previously saved file.

<b>Spreadsheet/Table columns</b>	Defines the order of the data in the selected equipment list file. Assign column numbers to data categories (such as Manufacturer, Catalog, and Installation) in the Equipment List Spreadsheet Settings dialog box.
<b>Save settings</b>	Saves the column information in a text file for reuse. The filename is user-defined with the extension <i>.wde</i> .

## Insert a copy of a panel footprint

### Insert a copy of a panel footprint

Copies a selected panel footprint on the active drawing.

Use the Copy Footprint tool instead of AutoCAD Copy when a panel component footprint has a balloon or a nameplate associated with it. The program establishes invisible Xdata pointers tied to a footprint, and updates them in the Copy Footprint operation.

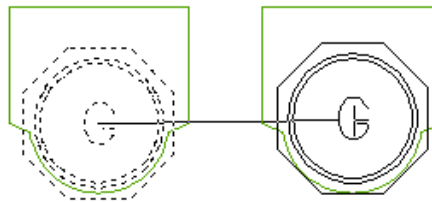

- 1 Click Panel tab ► Edit Footprints panel ► Copy Footprint.
- 2 Select the panel component to copy.
- 3 Click the drawing to specify the insertion point or enter a value.  
The Panel Layout - Component Insert/Edit dialog box displays.
- 4 Specify any necessary values such as the component tag, catalog information, or description.
- 5 Click OK.

## Use panel templates and assemblies

You can use templates to create a panel layout drawing or to add attributes to footprints automatically during insertion time. You can Wblock assemblies of panel components out to disk for insertion later.

### Panel layout template drawings

You can set up an AutoCAD template drawing for panel layout drawings with the WD\_PNLM block pre-inserted and set up with your own default settings. You can also set up client-specific template drawings and reference the appropriate one when starting a new AutoCAD Electrical panel drawing.

### Attribute template drawings

You can set up to have visible attributes added to any footprint automatically at footprint insertion time. Using non-intelligent footprint representations can insert with smart AutoCAD Electrical attributes added automatically, on the fly.

There are five attribute template drawings:

<b>wd_ptag_addattr_comp.dwg</b>	component footprints
<b>wd_ptag_addattr_trm.dwg</b>	terminal footprints
<b>wd_ptag_addattr_wtrm.dwg</b>	terminal with wire no. as terminal number
<b>wd_ptag_addattr_iteballoon.dwg</b>	balloons
<b>Wd_ptag_addattr_pnltermstrip.dwg</b>	terminal footprints (when inserted by Level/Sequencing tools)

If the appropriate attribute template exists, the following steps are performed when a panel footprint is inserted.

- 1 Find the center of the footprint by collecting and averaging the objects that make up the footprint.
- 2 Insert the attribute template at the calculated center of the footprint.
- 3 Make sure there are no duplicate attributes. If duplicate attributes are found, the attribute from the footprint is kept.
- 4 Reblock the added attributes with the inserted footprint.

- 5 Add the schematic data to the footprint. If the target attribute exists, the data is added as attribute data. If the target attribute does not exist, the data is added as invisible Xdata.

### Panel assembly

You can Wblock assemblies of panel components out to disk for insertion later. Use the Insert Panel Assembly utility instead of the AutoCAD Insert/Explode command when to insert a WBlocked group of panel component footprints with balloons or nameplates. Since AutoCAD Electrical establishes invisible Xdata pointers when they are tied to a footprint, they are properly updated when inserted using this utility. Use the Copy Assembly utility to copy panel assemblies on the active drawing.

### Insert panel footprint assemblies

Inserts a WBlocked panel footprint assembly.

Use the Insert Panel Assembly utility instead of the AutoCAD Insert/Explode command to insert a group of panel component footprints with balloons or nameplates. The program establishes invisible Xdata pointers tied to a footprint, and updates them in the Insert Panel Assembly operation.

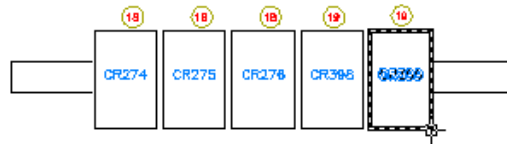

- 1 Click Panel tab ► Insert Component Footprints panel ► Panel



- 2 Specify whether to add the intelligence needed for each block to be treated as an AutoCAD Electrical footprint.
- 3 Click OK.

- 4 In the Wblocked Assembly to Insert dialog box, select the assembly and click Open.
- 5 Specify the insertion point for the block.
- 6 Enter a rotation angle or press Enter to use the default.  
Your block is inserted onto the drawing at your picked point.

## Copy panel footprint assemblies

Copies one or more selected panel footprints.

The Copy Assembly utility copies a group of panel component footprints, balloons, and nameplates. You select the balloons or nameplates to copy with the footprints. The program establishes invisible Xdata pointers tied to a footprint and updates them in the operation.

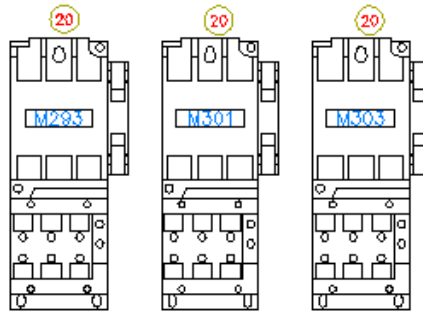

- 1 Click Panel tab ► Edit Footprints panel ► Copy Assembly.
- 2 Select the panel components to copy and right-click.
- 3 Enter a base point or displacement value.
- 4 Specify the second point and right-click.



# Footprint/Terminal Edit

## Edit a footprint or panel terminal

You can go back to a component at any time and edit values, such as tag, catalog assignment, location, installation, descriptions, ratings, and miscellaneous values. Related components update to match new values. In some cases, a footprint updates due to manufacturer, catalog, or assembly value changes.

### Panel layout - component insert/edit

Edits the panel footprint or terminal. Converts a selected block if not compatible with AutoCAD Electrical.

#### Insert Footprint (Icon Menu)

 **Ribbon:** Panel tab ► Insert Component Footprints panel ► Insert



Footprints drop-down ► Icon Menu.



 **Toolbar:** Panel Layout

 **Menu:** Panel Layout ► Insert Footprint (Icon Menu)

 **Command entry:** AEFOOTPRINT

Select the footprint to insert and specify the insertion point on the drawing.

#### Edit Footprint

 **Ribbon:** Panel tab ► Edit Footprints panel ► Edit.



 **Toolbar:** Panel Layout

 **Menu:** Panel Layout ► Edit Footprint

 **Command entry:** AEEDITFOOTPRINT

Select the footprint or nameplate to edit.

You can go back to a footprint at any time and edit values, such as tag, catalog assignment, location, installation, descriptions, ratings, and miscellaneous values. Related components update to match new values. In some cases, a footprint updates due to manufacturer, catalog, or assembly value changes.

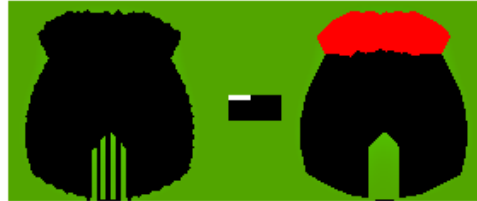

---

**NOTE** The dialog box options differ depending on whether you are inserting or editing a footprint or nameplate.

---

### Item Number

It is automatically assigned when the catalog part number values match an existing component that is already assigned an Item number. If no existing match is found, you can manually enter an item number. These item numbers, which can be linked to "smart" balloons, display in panel BOM and component lists.

<b>fixed</b>	If checked, marks an item number as fixed. If you run <a href="#">Resequence Item Numbers</a> on page 1602 later on, fixed item numbers do not change.
<b>Find</b>	Scans for the target component catalog assignment and assigns the item number if a match is found. If a catalog match is not found, a dialog box is displayed for item number assignment.
<b>List</b>	Displays a list of numbers found in the current drawing or project.
<b>Next</b>	Finds the next available item number.

### Catalog Data

Does a drawing or project-wide listing of similar components with their catalog assignments. During your editing session, the last MFG / CAT / ASSYCODE assignment for each component type you insert into your wiring diagram is

remembered. When you insert another component of that type, the catalog assignment of the previous component is set as the default (assuming a previous one was made during the current editing session).

<b>Manufacturer</b>	Lists the manufacturer number for the footprint. Enter a value or select one from the Catalog lookup.
<b>Catalog</b>	Lists the catalog number for the footprint. Enter a value or select one from the Catalog lookup.
<b>Assembly</b>	Lists the assembly code for the footprint. The Assembly code is used to link multiple part numbers together.
<b>Count</b>	Specifies the quantity number for the part number (blank=1). This value gets inserted into the "SUBQTY" column of a BOM report
<b>Unit</b>	Specifies the unit of measure, which can be displayed in the component list report.
<b>Catalog Lookup</b>	Opens the catalog database of the component from which you can manually enter or pick the Manufacturer or Catalog values. Search the database for a specific catalog item to assign to the currently selected component.
<b>Drawing</b>	Lists the part numbers used for similar components in the current drawing.
<b>Project</b>	Lists the part numbers used for similar components in the project.
<b>Multiple Catalog</b>	Inserts or edits extra catalog part numbers on to the currently selected component. You can add up to 99 part numbers. These multiple BOM part numbers appear as subassembly part numbers to the main catalog part number in the various BOM and component reports.
<b>Catalog Check</b>	Show how the selected item displays like in a Bill of Material template.

### **Rating**

Specifies values for each ratings attribute. You can enter up to 12 ratings attributes on a terminal. Select Show All Ratings to display a list of default values.

---

**NOTE** If this button is unavailable, the component you are editing does not carry any rating attributes.

---

### Component Tag

Any existing tags appear in the edit box. To define the component tag, edit the tag or type a specific tag in the edit box. Select Fixed if you do not want to update this tag on a retag.

<b>Schematic List</b>	Applies an ID tag number to link the panel component back to its equivalent device on the schematics.
<b>External list file</b>	Assigns a tag from an external list file.

### Description

Enter up to three lines of description attribute text.

<b>Drawing</b>	Displays a list of descriptions found in the current drawing so you can select similar descriptions to edit.
<b>Project</b>	Displays a list of descriptions found in the project so you can pick similar descriptions to edit.
<b>Defaults</b>	Opens an ASCII text file from which you can select standard descriptions.

### Installation/Location Codes

Changes the installation, location, mount, and group codes. You can search the current drawing or entire project for the codes. A quick read of all the current or selected drawing files is done and a list of installation codes used so far is returned. Select from the list to update the component with the codes automatically.

Assign short installation codes to components like "PNL" and "FIELD" so you can take full advantage of the AutoCAD Electrical ability to create location-specific BOM and component lists later.

### Switch Positions

Labels the positions of a selector switch.

### Show/Edit Miscellaneous

View or edit any attributes that are not predefined AutoCAD Electrical attributes.

## Panel layout - terminal insert/edit

### Insert Terminal (Manual)

 **Ribbon:** Panel tab ► Terminal Footprints panel ► Insert Terminals

drop-down ► Insert Terminal (Manual).



 **Toolbar:** Terminal Footprint



 **Menu:** Panel Layout ► Insert Terminal (Manual)

 **Command entry:** AEPANELTERMINAL

Select the method for inserting a terminal strip and place the terminal strip on the drawing.

### Edit Footprint

 **Ribbon:** Panel tab ► Edit Footprints panel ► Edit.



 **Toolbar:** Panel Layout



 **Menu:** Panel Layout ► Edit Footprint

 **Command entry:** AEEDITFOOTPRINT

### Tag Strip

These controls determine the overall tagging of the terminal strip in the project. The Installation, Location, and Tag Strip values define which strip the terminal belongs to.

---

**NOTE** You can assign short installation or location codes to components like "PNL" and "FIELD" to take full advantage of the AutoCAD Electrical ability to create installation or location-specific BOM and component lists.

---

<b>Installation</b>	Changes the installation codes. Click Browse to search the active drawing, entire project, and an external list (default.inst) for installation codes. Pick from the list to update the component with the installation code automatically.
<b>Location</b>	Changes the location codes. Click Browse to search the active drawing, entire project, and an external list (default.loc) for location codes. Pick from the list to update the component with the location code automatically.
<b>Tag Strip</b>	Specifies the Tag ID given to the terminal strip. If there is an existing name, it appears in the edit box. If not, you can enter a specific ID name or click the < and > buttons to increment or decrement the last digit/character in the Tag Strip value.
<b>Number</b>	Specifies the terminal number. If there is not PIN-LIST information, the < and > buttons increment or decrement the terminal number. You can also click Pick to select a text object or an attribute on the active drawing to use for the terminal number. If the panel footprint is already associated to a schematic symbol, this edit box is already populated with its value.

### **Modify Properties/Associations**

These controls support associations between schematic terminal symbols and their panel terminal footprint and between multiple schematic terminal symbols.

---

**NOTE** You cannot associate terminals using the Add/Modify or Break Out Panel options when you insert a terminal using the Insert Terminal (Schematic List) tool. However, once the terminal is inserted onto the drawing, you can modify the associations using these tools.

---

<b>Add/Modify</b>	<p>Displays the Add/Modify Associations dialog box. Select terminal strips and their respective blocks to make an association to the terminal symbol being inserted or edited.</p> <hr/> <p><b>NOTE</b> It is disabled if the active drawing is not part of the active project.</p> <hr/>
<b>Break Out Panel</b>	<p>Removes the selected terminal symbol out of the defined association. The properties from the original association and the levels of the terminal are maintained.</p>
<b>Block Properties</b>	<p>Displays the Block Properties dialog box where you can define and maintain terminal block properties.</p> <hr/> <p><b>NOTE</b> It is disabled if the active drawing is not part of the active project.</p> <hr/>

### Properties/Associations

The list box displays the status of the edited terminals association. It lists all associated terminal symbols from the schematic and terminal panel footprints. If the terminal symbol is being inserted for the first time, the list box only displays the reference for itself. The number of levels defined in the block properties displays at the top of the Properties/Associations group. The terminal number being edited is highlighted in the list box.

You can double-click in the list to modify the terminal association in the Add/Modify Associations dialog box.

---

**NOTE** Pin numbering is related to the terminal level and not the terminal tag number instance.

---

<b>Label</b>	<p>Lists the level description defined in the terminal block properties.</p>
--------------	--

<b>Number</b>	Lists the terminal numbers defined in the association. Only one terminal number is allowed per level and each level displays its respective terminal number or text. Panel terminal symbols do not display terminal numbers.
<b>PinL</b>	Lists the pin numbers defined left side of the terminal block. This data is entered into the L0nPINL attribute if present; otherwise, it is placed in the xdata.
<b>PinR</b>	Lists the pin numbers defined on the right side of the terminal block. This data is entered into the L0nPINR attribute if present; otherwise, it is placed in the xdata.
<b>Reference</b>	Lists the reference location of the terminal symbol in the project. The syntax is 'Sheet,Reference' based on the drawing configuration.

### **Catalog Data**

You can do a drawing-wide or project-wide listing of similar terminals with their catalog assignments. During your editing session, the last MFG / CAT / ASSYCODE assignment for each terminal you insert into your wiring diagram is remembered. When you insert another terminal of that type, the previous catalog assignment of the terminal is set as the default (assuming a previous one was made during the current editing session).

<b>Manufacturer</b>	Lists the manufacturer name for the terminal. Enter a value or select one from the Catalog lookup.
<b>Catalog</b>	Lists the catalog number for the terminal. Enter a value or select one from the Catalog lookup.
<b>Assembly</b>	Lists the assembly code for the terminal. The Assembly code is used to link multiple part numbers together.
<b>Item</b>	Specifies a unique identifier assigned to each terminal. The tag value can be manually typed in the edit box. Click the Item button to launch the Item Number dialog box to: <ul style="list-style-type: none"> <li>■ Search the drawing or project for an item value assigned to this catalog.</li> </ul>



- Fix the item number. If checked, marks an item number as fixed. If you run [Resequenece Item Numbers](#) on page 1602 later on, fixed item numbers do not change.

### Catalog Lookup

Opens the catalog database of the terminal from which you can select the Manufacturer and Catalog values. Search the database for a specific catalog item to assign to the selected terminal.

### Drawing

Lists the part numbers used for similar terminals in the current drawing.

### Project

Lists the part numbers used for similar terminals in the project. You can search in the active project, another project, or in an external file.

- **Active project:** All the drawings in the active project are scanned and the results are listed in a dialog box. Select from the list to assign your new terminal with a catalog number that is consistent with other similar terminals in the project.
- **Other project:** Scans each listed drawing in a previous project for the target terminal type and returns the catalog information in a subdialog box. Make your catalog assignment by picking from the list.
- **External file:** You can pull catalog assignments from a generic ASCII file created by a word processor or output from a spreadsheet or database program. A dialog box displays the contents of the selected text file. Find and highlight the desired entry. AutoCAD Electrical reads the line of text from the file and breaks it into its component parts. They are displayed in the left-hand list. For each relevant item, highlight it and then pick the appropriate category button in the center column. The highlighted item is transferred to the corresponding category (and then to the Insert/Edit dialog box once OK is clicked).

### Multiple Catalog

Inserts or edits extra catalog part numbers on to the selected terminal. You can add up to ten part numbers. These multiple BOM part numbers appear as subassembly part numbers to the main catalog part number in the various BOM and terminal reports.

## Catalog Check

Extracts the details from the catalog database to display what the selected item looks like in a Bill of Material template.

### **Descriptions**

Specifies the optional description attribute text to assign to the terminal block (up to three lines of text can be specified). Click Browse to search for all terminal descriptions in the project or active drawing. Select the description you want to copy to the edited terminal block by selecting it in the list and clicking OK.

### **Ratings**

Specifies values for each ratings attribute. You can enter up to 12 ratings attributes on a terminal. Select Show All Ratings to display a list of default values.

---

**NOTE** If this button is unavailable, the terminal you are editing does not carry any rating attributes.

---

### **Mount or Group**

Changes the mount and group codes. You can search the current drawing or entire project for the codes. A quick read of all the current or selected drawing files is done and a list of codes used so far is returned. Select from the list to update the component automatically with the codes.

### **Show/Edit Miscellaneous**

View or edit any attributes that are not predefined AutoCAD Electrical attributes.

### **External List**

Assigns information from an external list to specified data in the Panel Layout - Terminal Insert/Edit dialog box. Any existing information from the dialog box appears in the edit box. To define the information from the selected file, highlight the appropriate information in the Choices list. Select the appropriate button next to the edit box.

### **Add/modify associations**

This tool searches project terminal strips for existing terminal blocks, allowing you to associate a terminal symbol to an existing association or terminal.

## Insert Component

 **Ribbon:** Schematic tab ► Insert Components panel ► Insert Components

drop-down ► Icon Menu.

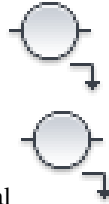

 **Toolbar:** Main Electrical

 **Menu:** Components ► Insert Component

 **Command entry:** AECOMPONENT

Select Terminals and Connectors from the dialog box and specify the insertion point on the drawing. In the Insert/Edit Terminal Symbol dialog box, Modify Properties/Associations section, click Add/Modify.

## Edit Component

 **Ribbon:** Schematic tab ► Edit Components panel ► Edit Components

drop-down ► Edit.

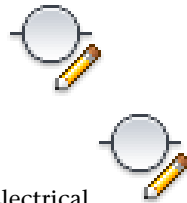

 **Toolbar:** Main Electrical

 **Menu:** Components ► Edit Component

 **Command entry:** AEEDITCOMPONENT

Select the terminal to edit. In the Insert/Edit Terminal Symbol dialog box, Modify Properties/Associations section, click Add/Modify.

---

**NOTE** This option is also available from the Panel Layout - Insert/Edit Terminal Footprint dialog box.

---

Modifications to the terminal symbol associations affect every terminal symbol in the association so all drawings must be available for editing. You cannot edit other terminal associations from this dialog box; only the associations of the selected terminal symbol can be edited.

## Active Association

Use this section to modify the terminal number. The Installation, Location, and Tag Strip values are not editable.

<b>Installation</b>	Displays the Installation value defined for the edited terminal symbol.
<b>Location</b>	Displays the Location value defined for the edited terminal symbol.
<b>Tag Strip</b>	Displays the tag strip value defined for the edited terminal symbol.
<b>Number</b>	(Unavailable for panel terminals) Specifies the terminal number. The displayed value is defined in the TERM01 attribute on the terminal symbol. <hr/> <b>NOTE</b> If this value is the wire number defined in the WIRENO attribute on the terminal symbol, you cannot change the value.

## Active Associations grid

Displays all terminal symbols that are currently associated to the terminal being edited. The terminal symbol that is being edited is highlighted in light blue. Right-click on a terminal symbol to move it up or down one level or select a terminal symbol and drag it to a new level location. Label and Pin information do not move with the terminal symbol number and reference since it is part of the terminal block property definition.

---

**NOTE** The panel symbol association is always at the bottom and cannot be selected for movement.

---

- **Level numbering:** Displays a level number for each level that is defined in the terminal properties. The level numbering for the panel symbol is “#.”
- **Label:** Lists the level description defined in the terminal block properties.
- **Number:** Lists the terminal numbers defined in the association. Only one terminal number is allowed per level and each level displays its respective terminal number or text. Panel ter-

terminal symbols do not display terminal numbers. Terminal levels with an assignment and a terminal that has not been assigned a terminal number display a “???” in this column.

- **PinL:** Lists the pin numbers defined on the left side of the terminal block. This data is entered into the LnnPINL attribute if present; otherwise, it is placed into Xdata.
- **PinR:** Lists the pin numbers defined on the right side of the terminal block. This data is entered into the LnnPINR attribute if present; otherwise, it is placed into Xdata.  
Pin numbering is related to the terminal level and not the terminal tag number instance.
- **Reference:** Lists the reference location for the terminal symbol in the project. The syntax is “Sheet,Reference” based on the drawing configuration.

## Select Association

### Terminal Strips

Displays all terminal strips inside of the active project. The tree contains three nodes to aid in finding a specific terminal block in the project. The nodes are: active project name, Tag Strip value (Installation and Location included) and terminal blocks.

- **Active Project node:** Displays the name of the active project.



- **Tag Strip Value node:** Displays the entire Installation, Location, and Tag Strip values for all terminal strips in the active project. The terminal block quantity displays at the end of the node string in parenthesis.



- **Terminal Block node:** Displays the terminal numbers defined on the block (separated by commas). The number of

levels defined in the block properties displays at the end of the node string in parenthesis. For example, 1,21,GND (3).

If a level is not represented on the schematic, an empty space represents it: 1, , GND (3). If a terminal has been assigned to the level, but the terminal does not have a number assignment, a '???' represents it: 1,???,GND (3).

#### Select Association grid

Displays all levels of the terminal selected in the tree. Select the level to place the edited terminal in and right-click to run the associate command (or click Associate).

#### Associate

Adds the edited terminal symbol to the terminal association. A terminal number is then inserted into the Number column and the Reference column is updated with the terminal reference defined in the drawing properties.

---

**NOTE** The grid row must be selected before you can perform the association.

---

This option is unavailable until you select a level in the grid control when editing a schematic terminal or until you select a terminal from the tree control when editing a panel footprint. A grid selection is not required for panel footprints since the footprint is associated to the entire terminal, not an individual level.

## Multiple Catalog

This tool allows you to insert or edit extra catalog part numbers on to the currently selected component or footprint. You can add up to 99 additional part numbers to any schematic or panel component on-the-fly. These multiple BOM part numbers appear as subassembly part numbers to the main catalog part number in the various BOM and component reports.

### **Multiple bill of material information**

This tool allows you to insert or edit extra catalog part numbers on to the currently selected component or footprint. You can add up to 99 additional part numbers to any schematic or panel component on-the-fly. These multiple BOM part numbers appear as subassembly part numbers to the main catalog part number in the various BOM and component reports.

On the Insert/Edit Component or Panel Layout - Component Insert/Edit dialog box, Catalog Data section, click Multiple Catalog.

---

**NOTE** You can also access this dialog box by clicking Multiple Catalog on the [Copy Catalog Assignment](#) on page 1299 dialog box.

---

The additional catalog part numbers are saved on the symbol as MFGn/CATn/ASSYCODEn attribute values. The "n" is the sequential code value "01" through "99" selected in the top list box. If these attributes are not present on the symbols, AutoCAD Electrical saves the information as Extended Entity Data (Xdata) on the block insert.

#### **Sequential code**

Adds up to 99 extra part numbers (in addition to the main catalog part number). Pick which one you want to add or inspect/edit. Click the list button to show all extra part numbers carried on the component.

#### **Catalog Data**

Specifies the catalog part number information such as the manufacturer and catalog number.

#### **Count**

Specifies the quantity number for the extra part number (blank=1). This value gets inserted into the "SUBQTY" column of a BOM report.

#### **Unit**

Specifies the unit of measure, which can be displayed in the component list report.

#### **Parts Catalog Lookup**

Lists the catalog database table that is to be referenced for the description information for the given Manufacturer/Catalog/Assembly combination. For each catalog entry, provide a name for the catalog look-up table. For the main catalog entry, this information is provided on the symbol itself but may not

be there for these catalog entries. Select List to pick from a list of tables that are contained in your catalog database file or Misc to use the MISC\_CAT table.

### Catalog Lookup

Checks for and displays catalog table information in the Parts Catalog dialog box for the selected component type.

### Catalog Check

Quickly performs a Bill of Material check and displays the result.

### Item Number

Assign an item number to the catalog number.

#### fixed

If checked, marks an item number as fixed. If you run [Resequence Item Numbers](#) on page 1602 later on, fixed item numbers do not change.

---

**NOTE** The fixed check box is available only when assigning the catalog to panel components.

---

#### Drawing: Find

Finds the assigned manufacturer, catalog, assembly code combination on components on the active drawing. If a match is found, the item number is assigned to this catalog. If a match is not found, a dialog box displays where you enter an item number or use the next available.

---

**NOTE** If the [Item Numbering Mode](#) on page 211 is Accumulate Project Wide, this button is disabled.

---

#### Drawing: List

Lists the item numbers along with each manufacturer, catalog, assembly code combinations in use on the active drawing.

---

**NOTE** If the [Item Numbering Mode](#) on page 211 is Accumulate Project Wide, this button is disabled.

---

#### Project: Find

Finds the assigned manufacturer, catalog, assembly code combination on components on the drawings in the active project. If a match is found, the item number is assigned to this catalog. If a match is not found, a dialog box displays where you enter an item number or use the next available.



---

**NOTE** If the [Item Numbering Mode](#) on page 211 is Reset with Each Drawing, this button is disabled.

---

**Project: List**

Lists the item numbers along with each manufacturer, catalog, assembly code combinations in use on the drawings in the active project.

---

**NOTE** If the [Item Numbering Mode](#) on page 211 is Reset with Each Drawing, this button is disabled.

---

If the [Item Assignments](#) on page 211 project setting is set Per-Component Basis, this section is disabled.

## Multiple catalog part number assignments

This dialog box displays the order in which the extra part numbers appear in the various AutoCAD Electrical reports. You can add up to 99 additional part number assignments to a component.

On the Insert/Edit Component or Panel Layout - Component Insert/Edit dialog box, Catalog Data section, click Multiple Catalog. Click Sequential Code: List on the Multiple Bill of Material Information dialog box.

---

**NOTE** You can also access this dialog box by clicking Multiple Catalog on the [Copy Catalog Assignment](#) on page 1299 dialog box and clicking Sequential Code: List.

---

To change the order, highlight the part number and click Move Up or Move Down to move it in the list.

## Copy code values to components

### Copy code values to components

Use this tool to insert or copy installation, location, group, or mount code values to selected components. These values extract into various reports and may be useful for sorting or grouping purposes. Copied values show up on the target footprints as an attribute value if an attribute is present or as invisible Xdata.

---

**NOTE** This procedure uses the Copy Location Code tool, but you can use the same steps for any of the Panel Location Copy tools.

---

- 1 Click Panel tab ► Edit Footprints panel ► Copy Codes drop-down ►



Copy Location code.

- 2 In the Copy Installation\Location\Mount\Group to components dialog box, select the code names you want to copy.
- 3 Enter a value for the code:
  - Pick Master: Select a panel component from the drawing carrying the desired values for the all the codes you want to copy.
  - Enter a value in the edit box.
  - Drawing: Select a value from a list of values used on the active drawing.
  - Project: Select a value from a list of values used in the project.
  - Pick: Select a panel component from the drawing carrying the desired value for the specific code.
- 4 Click OK.

---

**NOTE** Schematic components only update installation or location values when the component carries an installation or location attribute respectively. Panel components update with either of the two data categories whether target attributes are present or not.

---

## Copy installation\location\mount\group to components

This tool lets you do mass copies of location, installation, group, or mount codes to all the components you select. You either type in the code, pick from an online list, or pick a similar master component.

### Copy Installation Code

-  **Ribbon:** Panel tab ► Edit Footprints panel ► Copy Codes drop-down



- Copy Installation Code.



-  **Toolbar:** Copy Codes

 **Menu:** Panel Layout ► Panel Miscellaneous Tools ► Copy Installation Code

 **Command entry:** AECOPYINST

### Copy Location Code

 **Ribbon:** Panel tab ► Edit Footprints panel ► Copy Codes drop-down



► Copy Location code.



 **Toolbar:** Copy Codes

 **Menu:** Panel Layout ► Panel Miscellaneous Tools ► Copy Location Code

 **Command entry:** AECOPYLOC

### Copy Mount Code

 **Ribbon:** Panel tab ► Edit Footprints panel ► Copy Codes drop-down



► Copy Mount code.



 **Toolbar:** Copy Codes

 **Menu:** Panel Layout ► Panel Miscellaneous Tools ► Copy Mount Code

 **Command entry:** AECOPYMOUNTCODE

### Copy Group Code

 **Ribbon:** Panel tab ► Edit Footprints panel ► Copy Codes drop-down



► Copy Group code.



 **Toolbar:** Copy Codes

 **Menu:** Panel Layout ► Panel Miscellaneous Tools ► Copy Group Code

### **Command entry: AECOPYGROUPCODE**

<b>Pick master</b>	Retrieves existing values by selecting a panel component from the drawing carrying the desired Installation or Location value you wish to copy.
<b>Installation</b>	Specifies to copy the installation code that you enter in the edit box.
<b>Location</b>	Specifies to copy the location code that you enter in the edit box.
<b>Mount</b>	Specifies to copy the mount code that you enter in the edit box.
<b>Group</b>	Specifies to copy the group code that you enter in the edit box.
<b>Drawing</b>	Selects a value for the code from a list of values used on the current drawing.
<b>Project</b>	Selects a value for the code from a list of values used in the project.
<b>Pick</b>	Selects a value for the code from a master list of values of the component.

## Delete Footprint

### Delete a footprint

Deletes the footprints you select, and removes any associated balloons.

You can search for related components, surf to them, and delete them.





- 1 Click Panel tab ► Edit Footprints panel ► Delete Footprint.
- 2 Select the footprints to delete.
- 3 Press Enter.

## Layout Wire Connection Annotation

### Add wire information to footprints

Insert schematic wire connection information on to panel footprint representations. After you add wire numbers to your schematics, annotate panel footprint symbols with this information. You can build panel footprint symbols with target attributes used for the wire connection information. If these attributes are not present on the panel footprint, an MTEXT entity is added to carry the wire information.

#### Target Attributes

If the panel footprint blocks carry certain target attributes, they are used for the wire information. Each wire connection attribute definition is tied to a terminal attribute definition (TERMxx) by the matching two digit suffix on each attribute tag pair. The default value of the TERMxx attribute is used to match up the wire connection information from the schematic components.

- **TERMxx** - incremented for each wire connection. Carries the default pin value for the wire connection. The two digit suffix relates the attribute to the wire annotation attributes, WIRENOxx, WDEVxx, and WLEVxx.
- **WIRENOxx** - wire connection information is written to this attribute. Optionally, use WIRENOxxA, WIRENOxxB, and so on, to separate multiple wire connections across multiple attributes.
- **WDEVxx** - if present, the connected component part of the annotation is broken out and placed on this attribute.
- **WLAYxx** - if present, the connected wire layer part of the annotation is broken out and placed on this attribute.

For example, here is a footprint representation for a 4-pole relay.

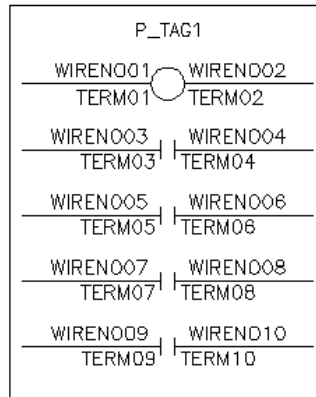

The TERMxx attribute definition default values match the default pin values for the relay, for example:

- Parent coil - K1, K2
- Child contact pairs - A1X/A1Y, A2X/ A2Y, A3X/A3Y, A4X/A4Y

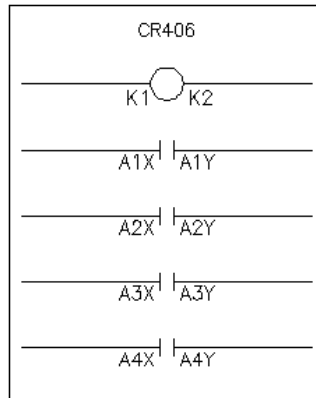

When the wire connection information is added to the footprint, the match is made based on the TERMxx value match.

---

**NOTE** You can build two sets of panel footprint symbols: one set that does not carry the target attributes for wire information and a set that does. When you insert your panel symbols from the schematic extract, select Use Footprint Tables to access the first set of symbols or select Use Wiring Diagram Tables to access the second set.

---

## MText

The default MText insertion point is the same as the insertion point of the footprint block. The default text size either matches that of existing wire number attributes found on the footprint symbol or, if none present, the MText size is forced to match the current value of the AutoCAD system variable "TEXTSIZE".

To predefine the MText insertion point, text size, and text style on footprint blocks, insert an invisible attribute "WXREF" on your footprint block library symbol. Open up each footprint symbol in AutoCAD and insert a blank attribute definition "WXREF". Put its origin at the point where you want AutoCAD Electrical to insert the MText wire connection information. Mark this attribute definition invisible and set its text size and style to the desired MText size and style.

## Add wire information to footprints

Inserts schematic wire connection information on to panel footprint representations.

After you add wire numbers to your schematics, annotate panel footprint symbols with this information. You can build panel footprint symbols with target attributes used for the wire connection information. If these attributes are not present on the panel footprint, a new or updated MTEXT entity displays the wire information.

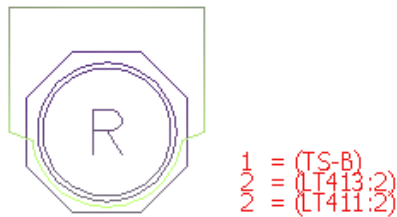

- 1 Click Panel tab ► Insert Component Footprints panel ► Wire



Annotation. # #

- 2 Specify to export the data for the active drawing or the entire project and click OK.

- 3 Select the wire numbering format to use.
- 4 Select the layout devices to update with the schematic wire connection information.
- 5 Click OK.
- 6 If you are exporting the data for the entire project, select the drawings to process, and click OK.

## Schematic wire numbers -> panel wiring diagram

Annotates panel footprint symbols with wire connection information extracted from selected schematics.

 **Ribbon:** Panel tab ► Insert Component Footprints panel ► Wire



 **Menu:** Panel Layout ► Wire Annotation of Panel Footprint

 **Command entry:** AEWIREANNOTATION

<b>Panel connection annotation for</b>	Specifies to create an annotation for the active drawing, object in the drawing, or the entire project.
<b>Freshen</b>	Updates the wire connection table with the out-of-date files
<b>List</b>	Lists the drawings that appear to be out-of-date with the wire connection table of the project.
<b>Report only (no drawing update)</b>	Specifies to update only the report - not the drawing.
<b>Location Codes to extract</b>	Extracts only the information for components with specific location values. Once you pick Named Location, type the location code in the box or click List: Drawing or List: Project to select from a list of used location codes. AutoCAD Electrical automatically creates a comma-delimited list for the named location search.



## Replaceable parameters for defining wire annotation

<b>%P</b>	Terminal pin text
<b>%Q</b>	Terminal pin TERMDESC text
<b>%I</b>	IEC-style installation code
<b>%L</b>	IEC-style location code
<b>%M</b>	Mount assignment (on panel footprint equivalent)
<b>%U</b>	Group assignment (on panel footprint equivalent)
<b>%W</b>	Wire number
<b>%C</b>	Cable tag + conductor/core color combination (format is "tag-color")
<b>%E</b>	Cable tag
<b>%J</b>	Cable conductor/core color
<b>%V</b>	Cable tag substituted for wire number if cable tag is non-blank. The wire number is displayed when a cable ID does not exist.
<b>%G</b>	Wire color/gauge (or wire layer name)
<b>%H</b>	Cable wire color substituted for wire number if cable color is non-blank. The wire layer is displayed when a wire conductor in conjunction with a cable ID does not exist.
<b>%T</b>	Terminal strip terminal pin assignment
<b>%K</b>	Terminal strip TERMDESC text - useful for multi-stack terminals
<b>%1</b>	Destination component tag ID. You can use only one of the (%number) parameters.
<b>%2</b>	Equivalent of "%1:%P" (component tag:term)
<b>%3</b>	Equivalent of "%1:%P:%D" (component tag:term:termdesc)
<b>%4</b>	Equivalent of "%L%1" (IEC component tag)

%5	Equivalent of "%L%1:%P" (tag:term)
%6	Equivalent of "%L%1:%P:%D" (tag:term:termdesc)
%7	Equivalent of "%I%I%1" (INST prefix+IEC component tag)
%8	Equivalent of "%I%L%1:%P" (tag:term)
%9	Equivalent of "%I%L%1:%P:%D" (tag:term:termdesc)

The part after the ":" is suppressed if the value is blank in %2 - %9 parameters. For example, %2=comp tag:term. The ":term" part is suppressed if blank.

### Schematic layout wire connection annotation

Defines the wire connection text format.

 **Ribbon:** Panel tab ► Insert Component Footprints panel ► Wire

Annotation. 

 **Toolbar:** Panel Layout 

 **Menu:** Panel Layout ► Wire Annotation of Panel Footprint

 **Command entry:** AEWIREANNOTATION

Make your selections and click OK.

---

**NOTE** You can build two sets of panel footprint symbols: one set that does not carry the target attributes for wire information and a set that does. When you insert your panel symbols from the schematic extract, select Use Footprint Tables to access the first set of symbols or select Use Wiring Diagram Tables to access the second set.

---

#### Format

There are two format edit boxes on the dialog box. The "Full" format is used if the target attributes are not found and MText is inserted. The "Partial" format is used if the target attributes are found (described later). Each format uses parameters that are then replaced with the specific wire information. AutoCAD Electrical provides some predefined formats for you to select from the list box

at the right; or you can enter your own format using [replaceable parameters](#) on page 236.

Parameters must be separated by non-blank delimiters for AutoCAD Electrical to be able to re-extract wiring diagram information into reports. For example, "%T=%W %1 %G" is not acceptable because there is only a space between the %W and %1 and %G parameters. Acceptable formats include "%T=%W (%1) %G" or "%T=%W / %1 (%G)" or "%T=%W (%1) %G".

---

**NOTE** You cannot use commas in the format. They signal multiple wire connection annotations onto a single wire connection attribute.

---

### **Additional options for the "To" component tag**

Additional options to include in the text.

<b>Add terminal pin as a suffix to tag</b>	Adds the terminal text as a suffix.
<b>Add terminal description to tag</b>	Adds any terminal description value as a suffix.
<b>Include installation prefix to IEC tag format</b>	Adds any installation value as a prefix.

### **View/Test**

Allows a preview or test of the report.

### **Suppress any duplicated annotation on each terminal**

Indicates to hide duplicated annotations so that they do not show on the report.

### **Delimiter between multiple instances on same line of text**

Enter the character used to separate multiple panel wire annotation values for the same wire connection.

### **If wire numbering converts to MText**

The default MText insertion point is the same as the insertion point of the footprint block. The default text size either matches that of existing wire number attributes found on the footprint symbol or, if none present, the MText size is forced to match the current value of the AutoCAD system variable "TEXTSIZE".

To predefine the MText insertion point, text size, and text style on footprint blocks, insert an invisible attribute "WXREF" on your footprint block library symbol. Open up each footprint symbol in AutoCAD and insert a blank attribute definition "WXREF". Put its origin at the point where you want AutoCAD Electrical to insert the MText wire connection information. Mark this attribute definition invisible and set its text size and style to the desired MText size and style.

---

**NOTE** You can define the default wire connection text format using the [Panel Configuration](#) on page 1527 dialog box. Click Panel Wire Connection Report XYZ Offset Reference Setup.

---

## Lookup Files

### Use the footprint lookup file

Let your project set of schematic wiring diagrams help drive the panel layout using the [Insert Footprint \(Schematic List\)](#) on page 1534 feature. AutoCAD Electrical uses the footprint lookup database (footprint\_lookup.mdb) to identify the footprints corresponding to the MANUFACTURER, CATALOG, and ASSEMBLYCODE attribute values of the schematic symbols. The database content is found at:

- **Windows XP:** C:\Documents and Settings\{username}\My Documents\Acade {version}\AeData\Catalogs\
- **Windows Vista, Windows 7:** C:\Users\{username}\Documents\Acade {version}\AeData\Catalogs\

#### How it works

- 1 You select a component from an AutoCAD Electrical extract file or select a component from an equipment list.
- 2 AutoCAD Electrical uses the manufacturer code of the component to determine the table name in the lookup file.
- 3 AutoCAD Electrical looks for a match in the manufacturer table for the catalog number (plus ASSEMBLYCODE if not blank).
- 4 If a match is found, AutoCAD Electrical retrieves the footprint block path/name (or optional geometry definition) from the matching record.

5 You insert the footprint representation into the drawing.

### AutoCAD Electrical search sequence

1st choice -- <project>\_footprint\_lookup.mdb in the subdirectory of the project

2nd choice -- footprint\_lookup.mdb in the subdirectory of the project

3rd choice -- footprint\_lookup.mdb in user subdirectory

4th choice -- footprint\_lookup.mdb in panel subdirectory

5th choice -- AutoCAD search paths

### Table naming convention

AutoCAD Electrical takes the MFG code of the target footprint and looks for a table, in the footprint\_lookup.mdb file, with that name. For example, if the MFG value of the footprint is SQD, then AutoCAD Electrical searches for a schematic lookup table called SQD. Manufacturer code of AB yields the table name AB.

The footprint lookup file supplied with AutoCAD Electrical points to symbols that are full-size physical representations of the device. There may be times you want to insert a footprint that is not necessarily a physical representation, but one that carries [wire connection attributes](#) on page 1585. With this type of symbol AutoCAD Electrical can annotate the symbol with schematic wire connection data to create a panel wiring diagram drawing. From the Schematic Components dialog box, if you select "Use Wiring diagram tables", AutoCAD Electrical accesses an alternate table in the footprint lookup table. This table matches the MFG code but attaches a "\_WD" suffix. The tables with the "\_WD" suffix are set up to insert a symbol that carries the wire connection attributes.

You must expand and modify these tables to meet your specific panel footprint needs. You can do this using tools provided with AutoCAD Electrical or through the use of a database program that can read/write the Access file format.

### Table format

Footprint lookup tables are in a Microsoft Access database file. Each record consists of these fields (in this order):

<b>CATALOG</b>	Catalog number, wild cards allowed
<b>ASSEMBLYCODE</b>	Optional assembly code value - internal AutoCAD Electrical use only

<b>BLKNAM</b>	Footprint block name with partial path or geometry definition
<b>DESCRIPTION</b>	Optional short description used for display purposes only

### Block name vs. geometry definition

You can encode a simple geometry definition in place of a footprint path/block name in the lookup file. For example, if a footprint shape for a given part number is a 3x4 rectangle, instead of creating and saving a 3x4 rectangle as a Wblocked .dwg file, you can encode the instructions for drawing the rectangle in the lookup file like the following syntax:

```
("LINE" "0,0" "@4.00,0" "@0,3.00" "@-4.00,0" "C")
```

The previous example follows the command sequence you type in to create the footprint outline. When AutoCAD Electrical comes across it instead of a path/block name in the lookup file, it executes the command sequence and blocks it on the fly.

### Edit footprint lookup files

You can make edits and additions to footprint lookup files using the Footprint Database File Editor tool or you can edit them directly using Microsoft Access.

- 1 Click Panel tab ➤ Other Tools panel ➤  ➤ Footprint Database



- 2 Select the Edit Existing Table button.
- 3 Select the table to edit and click OK.
- 4 In the Footprint lookup dialog box, decide if you want to edit a record or add a new one.
  - If you decide to edit a record, select the record to edit and click Edit Record.
  - If you decide to add a new record, click Add New.
- 5 Add or edit the record values and click OK.

The Catalog Number and Footprint block name, at a minimum, must be filled in to provide a key field for the search and a block or geometry definition for the matching footprint.

Your new record is added to the list. You can also immediately see any changes you made to an existing record.

- 6 Click Save to save your changes and keep the dialog box open for more editing, or click OK / Save/ Exit to save your changes and close the dialog box.

## Panel footprint lookup database file editor

Edits the catalog number --> footprint block name lookup file.

 **Ribbon:** Panel tab > Other Tools panel >  > Footprint Database

 File Editor.

 **Toolbar:** Panel Miscellaneous  
 **Menu:** Panel Layout > Database File Editor > Footprint Database File Editor

 **Command entry:** AEFOOTPRINTDB



The program uses the footprint lookup database to map catalog information from a schematic component to a specific panel footprint library symbol. There is a table for each manufacturer code.

Each entry in the table maps a given part number to its footprint block name. The table name must match the manufacturer code.

<b>Edit existing table</b>	Opens a sub-dialog box for editing existing manufacturer footprint lookup tables.
<b>Create new table</b>	Opens a sub-dialog box for creating new manufacturer footprint lookup tables.
<b>Create empty file</b>	Opens a sub-dialog box for creating a blank footprint lookup file. This option is available if a Footprint_lookup.mdb file does not exist in the designated location.

## Footprint lookup

This tool allows you to examine the records and, modify, delete, or add records.

 **Ribbon:** Panel tab > Other Tools panel >  > Footprint Database

  
File Editor.

 **Toolbar:** Panel Miscellaneous 

 **Menu:** Panel Layout > Database File Editor > Footprint Database File Editor



 **Command entry:** AEFOOTPRINTDB

Select the Edit Existing Table button, select the table to edit, and click OK.

<b>Edit record</b>	Opens a sub-dialog box for editing a record. Highlight the record and click the Edit button. Modify the record in the displayed sub-dialog box.
<b>Delete</b>	Removes an existing record.
<b>Add new</b>	Opens a sub-dialog box for creating a record. Fill in the fields. If the footprint block is not in an AutoCAD search path or an AutoCAD Electrical search path, include the part of the path that must be appended to one of these search paths (or you can enter the full path). If the new record is like an existing record, highlight the existing record before you click the Add button.

## Add or edit footprint record

This tool makes edits and additions to footprint look-up files. Edit them directly using Microsoft Access.

 **Ribbon:** Panel tab > Other Tools panel >  > Footprint Database

  
File Editor.





 **Toolbar:** Panel Miscellaneous

 **Menu:** Panel Layout ► Database File Editor ► Footprint Database File Editor

 **Command entry:** AEFOOTPRINTDB

Select the Edit Existing Table button, select the table to edit, and click OK. Click Add New or Edit Record on the Footprint Lookup dialog box.

---

**NOTE** The Catalog Number and Footprint block name, at a minimum, must be filled in to provide a key field for the search and a block or geometry definition for the matching footprint.

---

### Catalog Number

Specifies the catalog part number for the record. Click View to display a list of catalog fields on a per table basis. The catalog value may contain wildcards. Wildcard characters include:

\* = match any characters

? = match any single character

# = match any single numeric digit

@ = match any single alphabetic character

### Assembly code

Specifies the assembly code for the record.

### Footprint block name

The Block value can be a symbol name or AutoLISP expression. If the footprint block is not in an AutoCAD search path or an AutoCAD Electrical search path, include the part of the path that must be appended to one of these search paths (or enter the full path to the footprint block).

---

**NOTE** Add an asterisk prefix to explode the footprint on insertion.

---

**Browse**

Locates the block name.

**Pick**

Captures the block name if it exists on the current drawing.

**Geometry**

Substitutes a simple on-the-fly generated outline for the matching footprint. Several shapes are selectable or you can manually enter the definition.

**Icon Menu**

Opens an AutoCAD Electrical icon menu page for the block you specify in the Catalog Number section of the dialog box.  
Enter the menu name or browse for it. Once selected, click List to see a list of the submenu pages defined within that icon menu to select from or enter the number of the menu page to display and click OK.  
The menu number corresponding to the catalog number is then saved in the footprint lookup table.

**Comment**

Specifies the optional comment for the footprint record. This is for reference in this file only. It does not get extracted into any AutoCAD Electrical report.

**Syntax for encoding an icon menu page display for footprint selection**

```
(wdmenu "n:/myfolder/my_lookup_menu.dat" 5)
```

where

"n:/myfolder/my\_lookup\_menu.dat" = your AutoCAD Electrical icon menu file

5 = the "\*Mx" page number in that menu (x = 5)

This syntax is entered into the third edit box, the one labeled "Footprint block name," where the AutoCAD block name normally goes. It signals AutoCAD Electrical to open the icon menu file and jump to the menu page number ("5" in this example). Then AutoCAD Electrical waits for you to pick from the icon menu selection. The specific footprint block path/name to use is encoded into the icon menu file page "5" (excerpt from example "my\_lookup\_menu.dat" AutoCAD Electrical icon menu file shown in the following example).

```
**M5
```

```
300 AMP FRAME MCP
```

```
2-D plan view\mcp_300_2dpv.sld\MCP300-2Dp.dwg"
```

```
3-D plan insertion\mcp_300_3dpv.sld\MCP300-3Dp.dwg"
```

2-D side view\mcp\_300\_2dsv.sldl\$C=wd\_infpd "MCP300-2Ds.dwg"

3-D side insertion\mcp\_300\_3dsv.sldl\$C=wd\_infpd "MCP300-3Ds.dwg"

When you select an icon from the icon menu, it returns the footprint block ".dwg" file to use. This technique of footprint selection is useful for situations where there may be multiple possible orientations of a given footprint part number.

## Item Numbers/Balloons

### Add a balloon to a component

Assign an item or detail number to the main part number of a component or each multiple catalog part number through the Insert/Edit dialog box. It is stored as a data value on the block itself. To bring this item number out to a visible label, a balloon for example, use the Insert Balloon command and pick somewhere on the block. The item number of the component is retrieved, and then you are prompted to select start/end for a leader.

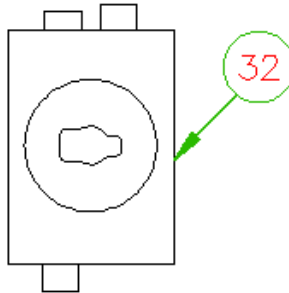

A single item number attribute, B\_ITEM, is inserted on the balloon symbol. You can set up a template to have additional visible attributes added to the balloon automatically at insertion time. Create this drawing with the attribute definitions you want to include with the balloon symbol:

\panel\wd\_ptag\_addattr\_itemballoon.dwg.

If an existing template is found, a copy of it gets exploded and merged (that is, blocked with the balloon as AutoCAD Electrical inserts it into the drawing).

The AutoCAD Electrical item balloon labels are smart in that they update automatically if the item number of the component is changed through the EDIT dialog box.

---

**NOTE** If the component has multiple item numbers, a multiple balloon is built up showing all item numbers.

---

### See also:

- [Item Numbering Setup](#) on page 211

### Add an item number balloon to a component

Inserts a balloon containing the item number of a selected component.

Prompts direct you to select points for an optional leader arrow. The item number in a balloon updates automatically when the item number changes on the component. You define the balloon type, text size, and arrow type with balloon setup.

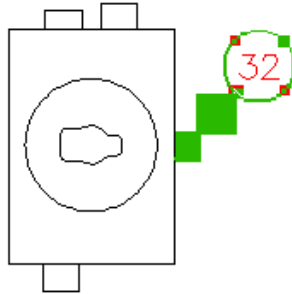

Prompts direct you to select points for an optional leader arrow. The item number in a balloon updates automatically when the item number changes on the component. You define the balloon type, text size, and arrow type with balloon setup.

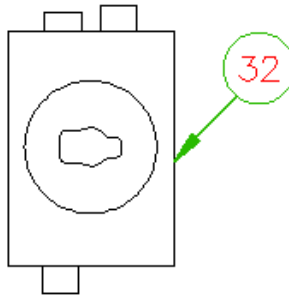

- 1 Click Panel tab ► Insert Component Footprints panel ► Balloon.



- 2 Select the component for the balloon or press S at the command line prompt to open the Balloon Setup dialog box.
- 3 Specify the leader start or balloon insertion point.
- 4 Specify the leader end and press Enter when you finish specifying the leader.  
You can also press Enter without specifying the leader end to create the balloon at the first picked point (the balloon does not have a leader).
- 5 Enter the item number if prompted and click OK.

---

**NOTE** You can also preset the balloon shape, size, text size, and arrow type from the balloon setup section on the Panel Configuration dialog box.

---

### See also:

- [Item Numbering Setup](#) on page 211

### Panel balloon setup

Sets the type of balloon marker for the footprint, marker size, margin, and text gap.

 **Ribbon:** Panel tab ► Other Tools panel ► Panel Configuration

drop-down ► Configuration.



 **Toolbar:** Panel Layout

 **Menu:** Panel Layout ► Panel Configuration

 **Command entry:** AEPANELCONFIG

Click Balloon Setup.

<b>Balloon</b>	<p>Specifies the type and size of balloon marker to insert. Choose from Circle, Ellipse, Polygon, and None.</p> <p>Circle - select either Diameter or Fit. Enter the diameter value or the Fit Margin, which sizes the circle automatically to fit the text plus the margin value.</p> <p>Ellipse - select either Axis or Fit. Enter the horizontal and vertical axis sizes or the Fit Margin.</p> <p>Polygon - select a polygon shape by picking on the current shape icon. Choose either Diameter or Fit.</p> <p>None (text only) - enter the gap value (the amount of space between the end of the leader line and the text).</p>
<b>Text</b>	<p>Specifies the text size for the marker.</p>
<b>Arrow</b>	<p>Specifies the arrowhead and size. Choose the type of arrowhead for the leader from the list and enter the arrowhead size in the box. These values correspond to AutoCAD leader/dimension system variables.</p>

## Resequencing item numbers

All Panel components and nameplates are extracted and their item numbers resequenced starting at the value you provide.

- Assigns incrementing item numbers for each new part number or multiple catalog number depending on the [Item Numbering Setup](#) on page 211.
- Ability to process only the components with blank item numbers, or process all. Processing all components overwrites existing item numbers.
- Updates existing balloons to match the new item number.

- Assigns the same item number to repeated part numbers. This is done on a drawing basis or project basis depending on the [Item Numbering Setup](#) on page 211.
- Fixed item numbers do not change. If multiple components have the same item number but only one is marked fixed, the item number is not resequenced.
- Ability to process components based on selected manufacturers.
- Ability to control the process order based on manufacturer.

### Resequence item numbers

- 1 Click Panel tab ► Edit Footprints panel ► Resequence Item Numbers.



- 2 Specify the beginning number to use.
- 3 If you want to assign item numbers only to components that do not already have one, check Process blank items only.
- 4 Specify to process the data for the current drawing or the entire project. If you select Project, you are able to select which drawings from within the project. If you select Current Drawing only, AutoCAD Electrical does not check other drawings for existing item number assignments.
- 5 If you want to process only the components with certain manufacturer values:
  - Uncheck Process all. The list displays containing all manufacturers used in the project.
  - Select which manufacturers to process using the Add and Remove buttons. Select a manufacturer or group of manufacturers and click Add or Remove.
  - Change the order of processing using the Move Up and Move Down buttons. Select a manufacturer or group of manufacturers and click Move Up or Move Down. The default order is alphabetical.
- 6 Click OK.
- 7 If Project is selected, select the drawings to process.

---

**NOTE** Fixed item numbers do not change.

---

### See also:

- [Item Numbering Setup](#) on page 211
- [Fixing item numbers](#) on page 1605

## Resequence panel item numbers

Extracts all panel components and resequences their item numbers starting at the value you provide.

 **Ribbon:** Panel tab ► Edit Footprints panel ► Resequence Item Numbers.



 **Toolbar:** Panel Miscellaneous



 **Menu:** Panel Layout ► Miscellaneous Panel Tools ► Resequence Item Numbers

 **Command entry:** AERESEQUENCE

Resequencing is based on the main MFG/CAT/ASSYCODE value combination. Based on your item numbering setup, it either ignores or assigns an item number to additional multi-catalog numbers. Fixed item numbers do not change.

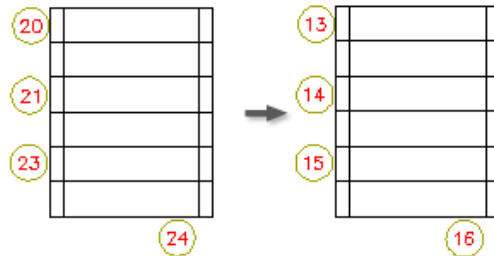

**Start**

Specifies the beginning number to use. Add leading zeros if desired (ex: "001" instead of "1") to enable better report sorting on item number.



<b>Process blank items only</b>	Check to skip any existing item numbers even if not fixed.
<b>Drawings to Process</b>	<p><b>Project</b> - process the entire project.</p> <p><b>Active drawing (all)</b> - process components on the active drawing only.</p> <p><b>Active drawing (pick)</b> - select the components for processing.</p>
<b>Manufacturers to Process</b>	<p>Defines the manufacturers to process and the order to process them. If you want to process only the components with certain manufacturers or define the order:</p> <ul style="list-style-type: none"> <li>■ Uncheck <b>Process all</b>. The list of all manufacturers used in the project displays.</li> <li>■ Check <b>Allow duplicate item numbers</b> to allow duplicate item numbers between the selected manufacturers and existing item numbers on components with unselected manufacturers.</li> <li>■ Use the <b>Add</b> and <b>Remove</b> buttons to indicate which manufacturers to process. Select a manufacturer or group of manufacturers and click Add or Remove.</li> <li>■ Use the <b>Move Up</b> and <b>Move Down</b> buttons to change the order of processing. Select a manufacturer or group of manufacturers and click Move Up or Move Down. The default order is alphabetical.</li> </ul>

---

**NOTE** The default process order is alphabetical.

---

### See also:

- [Item Numbering Setup](#) on page 211

## Fixing item numbers

Assign an item or detail number to the main part number of a component or each multiple catalog part number through the Insert/Edit dialog box. If you do not want an item number to change when you run [Resequence Item Numbers](#) on page 1602 later on, mark an item number as fixed.

Mark an individual item number as fixed on the Insert/Edit dialog box for the panel component. Run the [Project-wide utility](#) on page 1193 to fix or unfix all item numbers.

## Fix/unfix all item numbers project-wide



- 1 Click Project tab ► Project Tools panel ► Utilities.
- 2 Select from the options on the Item Numbers: Fix/Unfix drop-down list.
  - No Change** - do not modify the status of any existing item numbers. This option is the default.
  - Set all to fixed** - change all existing items numbers to fixed. If you run Resequence Items Numbers later on, fixed item numbers do not change.
  - Set all to normal** - clear all fixed item numbers. If you run Resequence Items Numbers later on, normal item numbers update.
- 3 Click OK.  
The Select Drawings to Process dialog box displays.
- 4 Select the drawings you want to process.
- 5 Click OK.

## Project-wide utilities

Provides the means for operations on wire numbers, component tags, attribute text, wire types, and item numbers. You can define scripts and apply them project-wide.



 **Ribbon:** Project tab ► Project Tools panel ► Utilities.



 **Toolbar:** Project

 **Menu:** Projects ► Project-Wide Utilities

 **Command entry:** AEUTILITIES

Select project drawings and perform any of the following:

- Erase, reset, fix, or unfix wire numbers.
- Fix or unfix component tags.
- Fix or unfix item numbers.
- Clear signal cross-referencing.
- Run a user-specified script file.
- Change attribute text size or style.
- Import wire types from another drawing or drawing template.

You can have multiple drawings open at any time. However, to maximize performance and memory usage, minimize the number of open drawings when running project-wide commands.

#### **Wire Numbers**

Select to keep wire numbers the same, erase specified wire numbers, reset specified wire numbers, or set wire numbers to fixed or normal.

#### **Signal Arrow Cross-reference text**

Select to maintain the signal arrow cross-reference text or to remove all signal arrow cross-reference text across the current project.

#### **Parent Component Tags: Fix/Unfix**

Select to maintain the component tags or to set all parent component tags to fixed or normal across the current project.

#### **Item Numbers: Fix/Unfix**

Select to maintain the item numbers or to set all item numbers to fixed or normal across the current project. If you run [Resequence Item Numbers](#) on page 1602 later on, fixed item numbers do not change.

#### **Change Attribute**

##### **Change Attribute Size**

Click Setup to select the attributes to change, and then enter the height and width definitions for the selected attributes.

---

**NOTE** If you do not want the attribute height or width to change, do not enter a value definition.

---

### Change Style

Click Setup to select a text font to apply to the text style used on component attributes.

### For each drawing

Enter the name or browse to a command script file to use for each drawing in the current project or to purge all blocks.

### Wire Types

Imports wire types defined on another drawing or drawing template. Enter the drawing or template name or browse to it using the browse button. The program reads the specified drawing and extracts all wire type information. Click Setup to display the [Import Wire Types](#) on page 903 dialog box where you:

- Select the wire types to import.
- Define whether to overwrite any Wire Numbering and USERn differences for existing wire types.
- Define whether to overwrite color and linetype differences for existing wire layers.

## Nameplates

### Insert nameplates

A nameplate is inserted on to the drawing as a block. It can either be referenced to an existing component footprint block or inserted as a stand-alone nameplate.

When tied to a component footprint, the component footprint is the parent and the nameplate is a child of that parent. AutoCAD Electrical establishes the link automatically by using invisible Xdata pointers on each block. It is different from the schematic parent/child link where a common "TAG1/TAG2" tag ID defines the relationship. AutoCAD Electrical automatically annotates the nameplate with the description data lines and tag value of the parent (if the nameplate block carries these target attribute names).

## Insert a nameplate

Several generic, rectangular nameplates with stretchable boundaries are provided. Three generic nameplates are shown on the panel icon menu nameplates page. Each of them consists of a nested block, which AutoCAD Electrical explodes and groups upon insertion. The rectangular outline of the resulting nameplate can be stretched using AutoCAD Grips or the Stretch Window command.

- 1 Click Panel tab ► Insert Component Footprints panel ► Insert



Footprints drop-down ► Icon Menu.

- 2 Select Nameplates from the list.
- 3 Select the desired nameplate from the dialog box.
- 4 Pick the target footprint and press Enter.  
To insert a stand-alone nameplate, simply press Enter without first selecting a component.
- 5 Pick the insertion point and move your cursor to rotate the nameplate to the desired alignment. Click the left mouse button to end the dynamic insertion.
- 6 Specify the nameplate tag, description, installation and location codes, and catalog data in the Panel Layout - Nameplate Insert/Edit dialog box. AutoCAD Electrical immediately annotates the nameplate with a copy of the description data that it finds carried on the footprint (which is the same description that is found on the schematic representation of the component).
- 7 Click OK to insert the nameplate.

---

**TIP** Use AutoCAD MOVE command to position the nameplate in relation to the parent footprint.

---

## Create your own stretchable nameplates

Use this example to create your own stretchable nameplate symbols.

- 1 On a new blank drawing, insert the attribute definitions P\_TAG1, and DESC1 through DESC3.
- 2 Save the drawing as npxtd3.dwg.

- 3 On a new blank drawing, insert the first drawing as a block at 0,0 using the AutoCAD Insert command.
- 4 Draw a polyline rectangle around the block.
- 5 Save the drawing as \_npxtd3.dwg.
- 6 Click Panel tab ► Other Tools panel ► Icon Menu Wizard. 
- 7 Select the panel icon menu, for example ACE\_PANEL\_MENU.DAT.
- 8 Double-click Nameplates to open the nameplates menu page.
- 9 Click the Add button and select Command.
- 10 Enter:  
**Name:** Generic, TAG and 3 DESC  
**Image file:** Active  
**Command:** wd\_inrnp\_xg "" "" "" "\_NPXSTD3"
- 11 Click OK on the Add Icon - Command dialog box.
- 12 Click OK on the Icon Menu Wizard dialog box.

## Panel Leveling/Sequencing Tools

### Remove sequencing assignments

#### Remove sequencing assignments

Routing assignments found on components, boundary boxes, or terminals can be removed when no longer needed.

- 1 Enter AEREMOVELEVEL at the command prompt.
- 2 Select the terminal strip, component, or boundary box to remove the assignments from.  
The leveling assignments are automatically removed.
- 3 Press ESC to exit the command.

## Show sequencing assignments

### Show sequencing assignments

You can select a supplementary terminal strip to display its defined leveling assignments to the command line. You can also select two panel footprint symbols to display wire connection information in a visual path on the screen.

#### Show terminal strip sequencing assignments

- 1 Enter AESHOWTERMINALSEQ at the command prompt.
- 2 Select a supplementary terminal strip.  
The leveling assignments for the selected terminal strip display in the command line. You see something like: LEV4-LEV1=001-001-001-001.
- 3 Press ESC to exit the command.

#### Show footprint sequencing assignments

- 1 Enter AESHOWFPSEQUENCE at the command prompt.
- 2 Select footprint to show the routing path from.
- 3 Select the device to show the path to.  
The wire connection information for the selected footprints display on the screen.
- 4 Press ESC to exit the command.

## Swap terminal strip wire text

### Swap terminal strip wire text

Swaps wire annotation text from one side of the terminal strip to the other. The Internal and External default definition applies when the terminal strip is initially placed.

- 1 Enter AEPANELTERMINALSWAPTEXT at the command prompt.
- 2 Select the wire annotation text to swap.  
The wire annotation is flipped to the other side of the selected terminal strip.
- 3 Press ESC to exit the command.

## View/edit panel component connection sequence

### View/edit panel component connection sequence

This tool allows you to view and rearrange the sequencing of all panel footprint components that share a common set of Level 1-4 level code assignments. This coding, when present, influences the way that AutoCAD Electrical calculates the wire connection from/to sequence. As it processes the schematic component representations and wiring, it checks for any coding found on the panel footprint and panel terminal strip representations. When present, it adjusts the from/to sequencing accordingly.

---

**NOTE** Leveling is required before assigning sequencing on the panel footprints.

---



 **Toolbar:** Panel Level/Sequencing

 **Menu:** Panel Layout ► Panel Level/Sequencing ► View/Edit Component Sequence

 **Command entry:** AEVIEWCOMPSEQ

Select a footprint with a set of level codes assigned to it.

The components that have level codes matching the picked footprint are displayed in the list box in the order they are inserted. It includes panel footprint components that might appear on drawings other than the active drawing (marked with "\*" in the list). To modify the order, select an entry in the list, then select Move Up or Move Down in the list. Multiple selection is supported.

<b>Move Up</b>	Moves the selected components up one spot in the list.
<b>Move Down</b>	Moves the selected components down one spot in the list.
<b>Pick Mode</b>	Defines the sequence by actual picks at each component. Pick near each component in the order of how you want the sequence to proceed from component to component. Picking is limited to components on the active drawing.
<b>Remove All</b>	Removes the component sequence information from all listed components.
<b>OK-new</b>	Saves the sequence assignments and writes them out to the panel footprint representations. The data is stored on attribute



WDLEV or as extended entity data (xdata) on the symbol if the target attribute is not available.

## Copy level assignments

### Copy level assignments

Define or capture a common set of level assignments for panel footprint components and then copy these 3-digit level codes to one or multiple footprints. This coding, when present, influences the way that AutoCAD Electrical calculates the wire connection from/to sequence. As it processes the schematic component representations and wiring, it checks for any coding found on the panel footprint and panel terminal strip representations. When present, it adjusts the from/to sequencing accordingly.



 **Toolbar:** Panel Level/Sequencing

 **Menu:** Panel Layout ► Panel Level/Sequencing ► Copy Level Assignments

 **Command entry:** AECOPYLEVEL

#### Level 4/Level 3/Level 2/Level 1

You can type in the level assignments or select from the drawing using Pick. Categories: Level 4 (shipping split - highest level), Level 3 (unit), Level 2 (cubical), and Level 1 (pan or plate - lowest level). You can copy all level information or unselect one or more level categories before copying.

An enabled, blank edit box indicates to erase any existing values and forces the use of the drawing-wide default value. If an edit box is unavailable, the existing value is not overwritten. Use the switches to enable or disable the edit box for each level category.

#### Terminal strips only

Applicable only the level assignments to copy to panel terminal strip representations, and the terminal strips are referenced on the schematics as well as the panel layout drawing. (In other words, they are not supplementary terminal strips that are only represented on the panel layout drawings).

Select this option, and then select one of the following:

- **Disable** (Default) AutoCAD Electrical treats the terminal connections through the terminal strip normally. It uses the level category code assignments of the terminal to influence how the from/to wire sequencing is calculated.
- **Enable** Processes the connection calculations of the terminal last. It checks each of the terminal potentials of the strip against those on any supplementary terminal strip found that is at the same level combination. For each potential match, it attempts to make the from/to calculation for that terminal to be a simple jumper assignment from the terminal strip's terminal up to the supplementary terminal strip. When a match is not found, the from/to calculation through the terminal strip operates in a normal fashion.

Pick

Selects the footprint representation on the drawing to copy the leveling code from.

## Insert panel wiring diagram terminal strip representation

### Insert panel wiring diagram terminal strip representation

Define a rectangle as a supplementary terminal strip to use in the wiring routing information over large control system equipment.



 **Toolbar:** Panel Level/Sequencing

 **Menu:** Panel Layout ► Panel Level/Sequencing ► Insert Terminal Strip Representation

 **Command entry:** AETERMINALSTRIP

Use generic marker only

Inserts a terminal strip with just the tag of the component, description text, and so on.

<b>Draw shapes</b>	Draws a rectangle, circle, or octagon to represent the terminal strip. Text and hidden information are inserted when drawn.
<b>Pick "just like" footprint</b>	Select a terminal strip from the drawing.
<b>Browse</b>	Pick a terminal strip from a list of .DWG files on disk.
<b>Pick</b>	Pick a non-AutoCAD Electrical block on the drawing to be instantly changed into a smart AutoCAD Electrical block.

## Insert/edit panel level assignment: terminal strip

### Insert/edit panel level assignment: terminal strip

Use this tool to view, assign, or edit 3-digit level codes on panel terminal strip representations. This coding, when present, influences the way that AutoCAD Electrical calculates the wire connection from/to sequence. As it processes the schematic component representations and wiring, it checks for any coding found on the panel footprint and panel terminal strip representations. If present, it adjusts the from/to sequencing accordingly.

This panel terminal strip coding can trigger supplementary or "shipping split" terminal strip references, not necessarily shown on the schematics, to be inserted into the schematic from/to wiring calculation. Specific wire connection sequencing defined directly on the schematics using the Define Wire Sequence command override this Panel level/sequencing assignment mechanism.



 **Toolbar:** Panel Level/Sequencing

 **Menu:** Panel Layout ► Panel Level/Sequencing ► Insert/Edit Panel Level Assignment

 **Command entry:** AEPANELLEVEL

Select an existing panel terminal strip representation.

#### Default

Displays a dialog box to set the drawing-wide default assignments for each of the four level categories. Values entered here become the default level

assignments for all unassigned panel layout footprint component and terminal strip representations on the active drawing.

---

**NOTE** This dialog box can also be accessed from the Panel Configuration dialog box.

---

Enter the optional 3-digit level codes (for example, 001, 002, and so on) for one or more of the four level categories. For example, if everything on the active drawing is in the fourth cubical of the second unit, and all of this is part of the first shipping split section, enter 004 for level category 2 (for example, cubical), 002 for level category 3 (for example, unit), and 001 for level category 4 (for example, highest category shipping section). With these defaults in place only the lowest level category 1 must be assigned on an individual panel terminal strip basis.

### **Pick**

Selects a panel layout footprint symbol or terminal strip representation on the active drawing and copies its level category settings over to the currently edited component. Multiple picks are allowed with each additional pick prompting you to overwrite or append.

### **Level 4/Level 3/Level 2/Level 1 edit boxes**

Shows the valid level code or codes assigned to each of the four level categories, Level 4 = shipping split (highest level), Level 3 = unit, Level 2 = cubical, and Level 1 = pan/plate (lowest level). The level code assignments should be 3-digit values and match up with level codes of panel layout footprints whose wiring is to pass through the terminal strip. Multiple code entries are comma separated.

If codes are not defined in the edit boxes, the drawing-wide default values displayed in the left-hand column of uneditable edit boxes are used (if defined).

### **Level code/location**

Controls whether the Level 1 edit box displays the 3-digit level code assignments or the LOC attribute value of the device. This location display mode is for display purpose only; the underlying 3-digit Level 1 code is always used for the sorting installation.

### **Level 4/Level 3/Level 2/Level 1 radio buttons**

Selects the level category at which the terminal strip representation operates. The categories are Level 4 = shipping split (highest level), Level 3 = unit, Level 2 = cubical, and Level 1 = pan/plate (lowest level). The level code assignment

codes should be 3-digit values and match up with level codes of panel layout footprints whose wiring is to pass through the terminal strip. Multiple code entries are comma separated.

### **Jumper Directly to Supplementary Terminal Strip: Enable/Disable**

This option is applicable to the terminal strip only if it is referenced on the schematics as well as the panel layout drawing (that is, it is not a supplementary terminal strip that only is represented on the panel layout drawings).

<b>Disable</b>	AutoCAD Electrical treats the terminal connections through this terminal strip normally. It uses the level category code assignments of the terminal to influence how the from/to wire sequencing is calculated.
<b>Enable</b>	AutoCAD Electrical saves this connection calculations of the terminal until last. It then checks each of the terminal "potentials" of the strip against those on any supplementary terminal strip found that is at the "same" level combination. For each potential match, it attempts to make the from/to calculation for that terminal to be a simple jumper assignment from the terminal strip's terminal up to the supplementary terminal strip. When no match is found, the from/to calculation through the terminal strip is done in a normal fashion.

### **Connection left/right**

Two-character code that controls whether the Level 1 assignments show "Panel Terminal Strip Report" connection information on the internal or external side of the terminal block. The first character represents the left side of the terminal strip and the second character represents the right side.

<b>Internal (I)</b>	Refers to the side of the terminal that "receives" wire connections from panel footprint components marked with the target Level 1 code.
<b>External (E)</b>	Refers to the side of the terminal strip with wiring going off to other Level 1 through four codes.
<b>Both (B)</b>	Means that both internal and external wiring is on the same side of the terminal strip with the other side empty, code of "x". (for example, for customer connections).

For example, a single Level 1 terminal strip marked with Level 1 code "001,002,004" runs between three back plates with mounted components, two on the left (footprint Level 1 codes of "001" and "002") and one on the right (footprint Level 1 codes "004"). If the terminal strip is marked as follows: "IE 001," "IE 002," and "EI 004," then wiring leaving the left-hand back plates attach to the terminal strip on the left-hand side ("I" in the first character position) and wiring leaving the right-hand plate attaches to the right side of the terminal strip ("I" in the second character position).

### **Maximum wires per terminal connection**

Defines the number of wires (either 1 or 2 per side) allowed per terminal connection in the Panel Terminal Strip report.

### **Maximum terminals**

Defines the total number of terminal blocks on the entire supplementary terminal strip for the Panel Terminal Strip report. A blank value indicates that the terminal strip length is undefined.

### **Maximum/minimum wire size**

Determines a range of wire sizes allowable to be connected to the supplementary terminal strip. Wires that are outside the allowed range of the terminal strip bypass it. A blank value in both maximum and minimum edit boxes indicates that this check is not performed.

A connected wire's size is extracted from the wire line's layer name. AutoCAD Electrical simply parses the wire's layer name for the first numeric value found within the name. For example, a wire layer name based on metric wire sizes of "WHITE-2.5MM^2" yields a size value of "2.5". A wire layer that might be set up for AWG wire sizes, "RED\_14\_XHW", indicates a size value of "14".

For example, the project used AWG-style wire sizes with layer names to match (for example, BLK\_12\_THHN and RED\_16\_MTW). The terminal block accepts wire sizes from thin AWG 24 through heavy AWG 12. Set up the maximum edit box to read "12" and the minimum edit box to read "24."

### **Allowed level to level connection direction**

Select from:

- |            |  |
|------------|--|
| <b>All</b> | Wiring from 3-digit code assignments both higher and lower than the terminal's assigned operating level code (the "Level 1-4 radio buttons" described previously) can pass freely through this terminal strip. |
|------------|--|

**Higher only**

Wiring from 3-digit code assignments higher than this terminal's assigned operating level code can pass through this terminal strip.

**Lower only**

Wiring from 3-digit code assignments lower than this terminal's assigned operating level code can pass through this terminal strip.

Example: the middle "002" shipping section has a Level 4 terminal strip at the left-hand end and another at the right-hand end. Wiring from anywhere in the first "001" shipping section must come in through the left-hand terminal strip. It is marked "Lower only". Wiring going on to the next shipping section "003" must pass through the right-hand terminal strip, marked "Higher only".

**Multiple terminal strip usage priority**

Provides priority for wiring information to apply to the supplementary terminal strip. If there can be multiple, valid terminal strip paths that match up with the level code combination of a given from/to inter-connection, the path chosen is influenced by this priority setting.

## Level code edit: boundary box

### Level code edit: boundary box

Use this tool to view or edit 3-digit level codes for boundary boxes. Devices placed within the boundary box take on the level codes of the boundary. The dialog box lists the number of device footprints found within the boundary and the number of devices that currently do not match the boundary default.



 **Toolbar:** Toolbar2

 **Menu:** Panel Layout ► Panel Level/Sequencing ► Insert/Edit Boundary Box Assignment

 **Command entry:** AEBOUNDRYBOX

Select a boundary box.

**Default**

Sets the drawing-wide defaults to use for the wire level codes. It references the panel drawing files default leveling assignment values defined in the Panel Configuration dialog box. Enter optional 3-digit level codes. They are applied as defaults when codes are not defined on footprint devices.

<b>Level 4/Level 3/Level 2/Level 1</b>	Specifies which level codes to use in the sequencing. Level 4 = ship split, Level 3 = unit, Level 2 = cubical, and Level 1 = pan/plate. The leveling assignment codes should be 3-digit values since they are used in for sorting component data in the project database. If codes are not defined in the edit boxes, the drawing-wide default values are used.
<b>Level code/location</b>	Indicates whether the level codes are displayed in the Level 1 input field or in the location code of the device defined on the schematic.
<b>Pick</b>	Selects another physical footprint symbol on the drawing to copy the level codes from.

## Insert/edit panel level assignment: component

### Insert/edit panel level assignment: component

Use this tool to view, assign, or edit 3-digit level codes and 4-digit sequence codes on panel footprint components. This coding, when present, can influence the way that AutoCAD Electrical calculates the wire connection from/to sequence. As it processes the schematic component representations and wiring, it checks for any coding found on the panel footprint and panel terminal strip representations. If present, it adjusts the from/to sequencing accordingly.

This panel level assignment coding also can trigger supplementary or "shipping split" terminal strip references, not necessarily shown on the schematics, to be inserted into the schematic from/to wiring calculation. Specific wire connection sequencing defined directly on the schematics using the Define Wire Sequence command overrides this Panel level/sequencing assignment mechanism.



 **Toolbar:** Panel Level/Sequencing

 **Menu:** Panel Layout ► Panel Level/Sequencing ► Insert/Edit Panel Level Assignment

 **Command entry:** AEPANELLEVEL

Select an existing footprint component.



### **Default**

Displays a dialog box to set the drawing-wide default assignments for each of the four level categories. Values entered here become the default level assignments for all unassigned panel layout footprint component and terminal strip representations on the active drawing.

---

**NOTE** This dialog box can also be accessed from the Panel Configuration dialog box.

---

Enter the optional 3-digit level codes (for example, 001, 002, and so on) for one or more of the four level categories. For example, if everything on the active drawing is in the fourth cubical of the second unit, and all of this is part of the first shipping split section, enter 004 for level category 2 (for example, cubical), 002 for level category 3 (for example, unit), and 001 for level category 4 (for example, highest category shipping section). With these defaults in place only the lowest level category 1 must be assigned on an individual panel terminal strip basis.

### **Level 4/Level 3/Level 2/Level 1**

Shows the level code assigned to each of the four level categories, Level 4 = shipping split (highest level), Level 3 = unit, Level 2 = cubical, and Level 1 = pan/plate (lowest level). The level code assignments should be 3-digit values and chosen with the idea that their sort order on a per-level category basis influences the actual inter-level wire sequence calculation.

The List button for each level category displays a dialog box showing the level combinations that are assigned so far. Picking from this dialog box assigns those same level category assignments to the currently edited panel layout footprint. If codes are not defined in the edit boxes, the drawing-wide default values displayed in the left-hand column of non-editable edit boxes are used (if defined).

### **Level code/location**

Controls whether the Level 1 edit box displays the 3-digit level code assignment or the LOC attribute value of the device. This location display mode is for display purpose only. The underlying 3-digit Level 1 code is always used for the sorting installation.

### **Pick**

Selects another panel layout footprint symbol or terminal strip representation on the active drawing and copies its settings over to the currently edited component

### **Bypass terminal strips**

Controls the wiring bypass of this component of one or more level categories of supplementary terminal strips. For example, special signal wiring passes from the currently edited component to some other components in a different cubical/unit/ship split section. To disable any supplementary terminal strip connections that might automatically be included in the from/to calculations between this edited component and other connected components identified in other level assignment combinations, switch all four bypass options on.

### **Sequence on Level 1**

Influences the wire connection sequencing of the schematic components whose physical footprints share the same combination of four level category assignments. The sequence assignment is a 4-digit number (for example, 0001, 0002, and so on) and is sorted to give a default wire connection sequence.

For example, all of the push button and pilot light footprint representations on a door layout carry the same Level 1 through Level 4 category code assignments, but carry sequence value assignments that increase from left to right and top to bottom on the layout. This means that AutoCAD Electrical calculates the from/to connections for a common wire starting at the top left and leaving the door at the component located in the bottom right-hand corner.

## **Pick list for panel terminal strip report/graphical report**

### **Pick list for panel terminal strip report/graphical report**

Select a supplementary terminal strip representation to display wiring information inside of a report generator dialog box, and later insert a terminal strip layout drawing.



 **Toolbar:** Panel Level/Sequencing

 **Menu:** Panel Layout ► Panel Level/Sequencing ► Panel Terminal Strip Report

 **Command entry:** AETERMINALSTRIPREPORT

All supplementary terminal strips found in the active drawing display in the dialog box. Select from the list or click Pick to select the terminal strip from the drawing. Once the terminal strip is selected (either from the list or the active drawing), the report displays in the Report Generator dialog box.

In the Report Generator dialog box, click Insert as Terminal Strip to define a graphical representation of the terminal strip for placement on the active drawing file.

## Panel terminal strip graphical report parameters

### Panel terminal strip graphical report parameters



 **Toolbar:** Panel Level/Sequencing

 **Menu:** Panel Layout ► Panel Level/Sequencing ► Panel Terminal Strip Report

 **Command entry:** AETERMINALSTRIPREPORT

Select a terminal strip and click OK. In the Report Generator dialog box, click Insert as Terminal Strip.

<b>Text height</b>	Defines the height of the terminal strip text.
<b>Terminal box width</b>	Defines the width of the boxes that make up the terminal strip.
<b>Terminal box height</b>	Defines the height of the boxes that make up the terminal strip.
<b>Group the terminals/text</b>	Inserts the graphical report as a set of grouped objects. You can select any member of the group or select the group as a whole. You can toggle group selection on and off by pressing CTRL+H or SHIFT+CTRL+A.
<b>Orientation</b>	Specifies the orientation for the terminal strip: vertical, left to right, or right to left.
<b>Wire connection format</b>	Each format uses parameters that are then replaced with the specific wire connection information. AutoCAD Electrical provides a predefined default format for you to select from the button. You can also enter your own format using the <a href="#">replaceable parameters</a> on page 236.
<b>Add spare terminals</b>	Displays extra terminals at the bottom of the graphical representation.



# Conduit Tools

# 20

## Overview of conduit tools

AutoCAD Electrical provides a set of utilities to help you label, size, and report on conduits. A conduit can be represented by a line or a poly line and by itself does not carry any intelligence. However, you may insert a conduit marker symbol and associate it to a conduit. The conduit marker symbol then carries wire information intelligence pulled from the AutoCAD Electrical drawings.

The first time (per AutoCAD session) that you insert a conduit marker, instruct AutoCAD Electrical to read the wire information. You can read the wire information from multiple drawings within the project, the current drawing, or read the existing WFRM2ALL table in the scratch database.

The conduit marker is a block inserted to add intelligence to a line or pline representing a conduit on a layout drawing. There are four blocks, called WWAYT, WWAYB, WWAYL, and WWAYR. The blocks are identical except for the insert point, T=top, B=bottom, L=left, R=right. The program picks which block based on the leader drawn.

### Conduit Marker Intelligence

<b>C_TAG</b>	Each marker receives a unique tag number. Use Setup to define the next tag.
<b>C_SIZE</b>	Conduit size, that is, 3/4"
<b>DESC1</b>	Optional description line 1
<b>DESC2</b>	Optional description line 2

<b>WIREINFO#</b>	Wire information for each wire included in the conduit. Wire# ; Wire Layer ; Wire Description ; Wire Size
<b>W_SPARES#</b>	Spare wires defined. Wire Description ; Count

## Insert conduit markers

### Use the Conduit Marker (Pick) tool

- 1 Click Panel tab ► Conduit Tools panel ► Conduit Markers drop-down



- Insert Marker.
- 2 Type S and press Enter to set up the conduit marker.
- 3 Specify the text for the marker tag and the scale for the marker block. Click OK.
- 4 Select the line that represents the conduit for the marker on the drawing.
- 5 Click points to define the leader and press Enter.
- 6 Select the conduit tag and press Enter.
- 7 Specify the conduit tag, catalog information, conduit size, description, or included wires in the Insert or Edit Conduit/WirewayLabel dialog box. The conduit marker symbol carries wire information intelligence pulled from the AutoCAD Electrical drawings.
- 8 Click OK.

### Use the Conduit Marker (From/To List) tool

- 1 Click Panel tab ► Conduit Tools panel ► Conduit Markers drop-down



- Insert From List.
- 2 Select the line that represents the conduit for the marker on the drawing.
- 3 Click points to define the leader and click Enter or the right mouse button.
- 4 Select the location codes for the conduit marker and click OK. These build the From/To combination for the Wire Run From/To Report.

- 5 Specify the conduit tag, catalog information, conduit size, description, or included wires in the Insert or Edit Conduit/WirewayLabel dialog box. The conduit marker symbol carries wire information intelligence pulled from the AutoCAD Electrical drawings.
- 6 Click OK.

### Edit all conduit marker information

Once you insert the conduit marker, you may need to supply some additional information for the marker. You can add the information at the time you insert the marker or select Edit Conduit Marker after it is inserted.



- 1 Click Panel tab ► Conduit Tools panel ► Edit Marker.
- 2 Pick the conduit to edit.
- 3 Change the conduit tag, catalog information, conduit size, description, or included wires in the Insert or Edit Conduit/Wireway Label dialog box.
- 4 Click OK.

### Insert or edit conduit/wire way label

There are three ways to insert a conduit marker depending on where you want to pick the wire information from. You can get the wire information from an actual device on your drawing represented by either a schematic symbol or a panel layout footprint symbol. You may also pull the wire information out of a wire from/to report based on your schematics. Finally, you can extract the information from multiple conduit markers to combine together into a separate conduit marker.

#### Conduit Marker (Pick)

**Ribbon:** Panel tab ► Conduit Tools panel ► Conduit Markers drop-down



**Toolbar:** Conduit Markers

**Menu:** Panel Layout ► Conduit Marker Tools ► Conduit Marker (Pick)



 **Command entry:** AECONDUITMARKER

Select the line that represents the conduit, click to define the leader, and then select layout devices or branching conduit markers and press Enter.

**Conduit Marker (From/To List)**

 **Ribbon:** Panel tab ► Conduit Tools panel ► Conduit Markers drop-down



 **Toolbar:** Conduit Markers

 **Menu:** Panel Layout ► Conduit Marker Tools ► Conduit Marker (From/To List)

 **Command entry:** AECONDUITMARKERLIST

Select the line that represents the conduit, click to define the leader.

**Edit Conduit Marker**

 **Ribbon:** Panel tab ► Conduit Tools panel ► Edit Marker.

 **Toolbar:** Conduit Markers

 **Menu:** Panel Layout ► Conduit Marker Tools ► Edit Conduit Marker

 **Command entry:** AEEDITCONDUITMARKER

Select an existing conduit marker.

**Conduit Tag**

AutoCAD Electrical selects a default conduit tag which can be overridden at any time. Click Drawing to use a tag used for similar conduits in the active drawing or click Project to use a tag used for similar conduits in the project. See [Conduit Marker Setup](#) on page 1631 to define the default format for the conduit tags.



## Size

The conduit size can be selected from the list of available sizes or entered in the box. To make it a little easier, AutoCAD Electrical can calculate the percentage full for each conduit size available. To do this AutoCAD Electrical needs [2 support files](#) on page 1632 containing wire size information and conduit size information. If there is not a .WW1 file or if the wire sizes are not in the file, the calculations are not made.

## Catalog Area

Assign catalog information to the conduit that will be extracted into a bill of materials report. You can do a drawing-wide or project-wide listing of similar conduits with their catalog assignments.

<b>Manufacturer</b>	Lists the manufacturer number for the component. Enter a value or select one from the Catalog lookup.
<b>Catalog</b>	Lists the catalog number for the component. Enter a value or select one from the Catalog lookup.
<b>Assembly</b>	Lists the assembly code for the component. The Assembly code is used to link multiple part numbers together.
<b>Item</b>	Specifies a unique identifier assigned to each component. The tag value can be manually typed in the edit box.
<b>Find</b>	Scans each drawing for the target conduit type and returns a list of what was found. You can make your catalog assignment by selecting from the list.
<b>Lookup</b>	Opens the catalog database of the conduit from which you can manually enter or select the Manufacturer or Catalog values. Search the database for a specific catalog item to assign to the selected conduit.
<b>Previous</b>	Scans the previous project to find an instance of the selected conduit and returns the conduit values. You can then make your catalog assignment by picking from the dialog box list.
<b>Drawing</b>	Lists the part numbers used for similar conduits in the current drawing.

## Project

Lists the part numbers used for similar conduits in the project. You can search in the active project, another project, or in an external file.

- **Active project:** All of the drawings in the current project are scanned and the results are listed in a sub-dialog box. Select from the list to assign your new conduit with a catalog number that is consistent with other similar conduits in the project.
- **Other project:** Scans each listed drawing in a previous project for the target component type and returns the catalog information in a sub-dialog box. Make your catalog assignment by picking from the dialog box list.
- **External file:** You can pull catalog assignments from a generic ASCII file created by a word processor or output from a spreadsheet or database program. A dialog box displays the contents of the selected text file. Find and highlight the desired entry. AutoCAD Electrical reads the line of text from the file and breaks it into its component parts. They are displayed in the left-hand dialog box list. For each relevant item, highlight it and then pick the appropriate category button in the center column. The highlighted item transfers to the corresponding category (and then to the Insert/Edit dialog box once OK is clicked).

## Multiple Catalog

Inserts or edits extra catalog part numbers onto the selected conduit. You can add up to ten part numbers to any conduit. These multiple BOM part numbers appear as subassembly part numbers to the main catalog part number in the various BOM and conduit reports.

## Catalog Check

Displays what the selected item looks like in a Bill of Material template.

### Description

Optional description lines.

### Wires to include in conduit/wireway

Define which wires to include in this conduit. Select from the available list in the upper box and add to the included list in the lower box. At any time you can pick from a from/to list by clicking Add Wires from List, or you can add wires from additional devices by clicking Pick Devices.

#### Add Wires from List

Adds wires by picking from a from/to list.

<b>Pick Devices</b>	Adds wires from additional devices.
<b>Spares</b>	Defines the spares to include in the conduit.
<b>Sort</b>	Sorts the list of conduit wires using an alphanumeric sort.

### Report/Print

Opens the Report Generator dialog box for running a Conduit marker report.

### Conduit marker setup

The conduit marker is a block inserted to add intelligence to a line or pline representing a conduit on a layout drawing. There are four blocks, called WWAYT, WWAYB, WWAYL, and WWAYR. The blocks are identical except for the insert point, T=top, B=bottom, L=left, R=right. The program picks which block based on the leader drawn.

 **Ribbon:** Panel tab ► Conduit Tools panel ► Conduit Markers drop-down



► Insert Marker.



 **Toolbar:** Conduit Markers

 **Menu:** Panel Layout ► Conduit Marker Tools ► Conduit Marker (Pick)

 **Command entry:** AECONDUITMARKER

Type S and press Enter.

<b>Conduit tag</b>	Specifies the marker tag. Each conduit marker receives a unique tag. Enter the text for the next tag. Each successive tag is incremented from the previous tag.
--------------------	--

<b>Scale</b>	Defines the scale to insert the conduit marker block.
--------------	---

### Add spare wires

Defines the spare wires to include in your conduit.

 **Ribbon:** Panel tab ► Conduit Tools panel ► Conduit Markers drop-down



► Insert Marker.



 **Toolbar:** Conduit Markers

 **Menu:** Panel Layout ► Conduit Marker Tools ► Conduit Marker (Pick)

 **Command entry:** AECONDUITMARKER

Click the Spares button on the Insert/Edit Conduit/Wireway Label dialog box.

<b>Select wires from</b>	Lists the spare wires that can be added to the conduit. The list is built from the .WDW support file.
<b>Type it</b>	If the wire type is not listed, type your spare wire description in the edit box.
<b>Wires to Add</b>	Lists the wires that to add to the conduit.
<b>Count</b>	Specifies the number of wires to add to the conduit. Adjust your quantity by typing the number or by selecting the <or > buttons.
<b>Update Quantity</b>	If you type the quantity, select this button to see the new quantity in the list.

## Overview of conduit marker support files

AutoCAD Electrical has a couple of support files containing wire size information and conduit size information: the .wdw file and the .ww1 file. These files are simple text files that can be edited with any text editor such as WordPad.

### **.WDW file**

The .WDW file contains the wire information. You may have a different file for each project. Create a projname.wdw file and put in the same directory as your project file (.WDP). To use the same file for all projects, create or modify the DEFAULT.WDW file in the USER folder. In the Project Manager, right-click the project name and select Settings to find the full path.

There should be a separate line in the file for each AutoCAD Electrical wire layer. The line has three fields, each field separated by a semi-colon. The first field is the actual wire layer name used on the drawing. The second field is the wire layer description. This description is used in the AutoCAD Electrical Wire Color/Gauge Label tool. The third field is the wire size.

For example, if you have a wire layer called 14\_RED\_THHN and you want the wire color/gauge label to read #14AWG RED for this layer, and the wire itself has a wire diameter of 0.0087, the line in the .WDW file would read:

```
14_RED_THHN;#14AWGRED;0.0087
```

### **.WW1 file**

The .WW1 file contains the conduit information. You may have a different file for each project. Simply create a projname.ww1 file and put in the same directory as your project file (.WDP). If you want to use the same file for all projects, then create or modify the DEFAULT.WW1 file in the USER folder (in the Project Manager, right-click the project name and select Settings to find the full path).

There should be a separate line in the file for each conduit. Each line has two fields. The first field is the conduit size that is shown in the Conduit Marker dialog box. The second field is the conduit size (the inner cross-sectional area of the conduit) so AutoCAD Electrical can determine how full the conduit is once you add up all the wire diameter sizes from the wires (pulled from the .WDW file). For example, if you have a 1-inch conduit with an inner diameter of 0.8 resulting in a cross-sectional area of 0.5024, the line in the .WW1 file reads:

```
1";0.5024
```

---

**NOTE** If you create a .WW1 file AutoCAD Electrical shows only the conduits listed in this file in the Conduit Marker dialog box.

---

## **Generate a conduit marker report**

### **Generate a conduit marker report**

You must have at least one conduit marker with wire connections on your drawing in order to run this report.

- 1 Click Panel tab ► Conduit Tools panel ► Conduit Reports drop-down



- Conduit Report.
- 2 Specify whether to run the report across selected drawings from the project, the current drawing, or selected conduit markers.

You can specify to display the last report run from this dialog box instead of running a new report by clicking the Redisplay Last Run button.

- 3 Click OK.
- 4 Select the drawings or conduit markers to process (depending on whether the report is run across the projector selected markers).
- 5 In the Report Generator dialog box, change the report format. You can specify to add the time and date, title line, project lines, column labels, page numbers, and blank spaces between report entities.
- 6 (Optional) Click Edit Mode to edit the report.
- 7 If the report is formatted correctly, specify to print the report, put it on the drawing, or save the report to a file.

## Conduit marker report

This utility extracts conduit marker information into a report. Extractable conduit marker symbols are named "WWAY\*". A conduit can be represented by a line or a polyline and by itself does not carry any intelligence. However, you can insert a conduit marker symbol and associate it to a conduit. The conduit marker symbol then carries wire information intelligence pulled from the AutoCAD Electrical drawings.

 **Ribbon:** Panel tab ► Conduit Tools panel ► Conduit Reports drop-down

► Conduit Report. 

 **Toolbar:** Conduit Reports 

 **Menu:** Panel Layout ► Conduit Marker Tools ► Conduit Marker Report

 **Command entry:** AECONDUITMARKERRPT

Decide if you want to run the report across selected drawings from the project, the active drawing, or selected conduit markers.

# Generate a conduit routing report

## Generate a conduit routing report

You must have at least one conduit marker with wire connections on your drawing in order to run this report.

- 1 Click Panel tab ➤ Conduit Tools panel ➤ Conduit Reports drop-down



- 2 Specify whether to run the report across selected drawings from the project, the current drawing, or selected conduit markers.  
You can specify to display the last report run from this dialog box instead of running a new report by clicking the Redisplay Last Run button.
- 3 Click OK.
- 4 Select the drawings or conduit markers to process (depending on whether the report is run across the projector selected markers).
- 5 In the Report Generator dialog box, change the report format. You can specify to add the time and date, title line, project lines, column labels, page numbers, and blank spaces between report entities.
- 6 (Optional) Click Edit Mode to edit the report.
- 7 If the report is formatted correctly, specify to print the report, put it on the drawing, or save the report to a file.

## Wire/conduit routing report

AutoCAD Electrical provides a set of utilities to help you label, size, and report on conduits. A conduit can be represented by a line or a poly line and by itself does not carry any intelligence. However, you can insert a conduit marker symbol and associate it to a conduit. The conduit marker symbol then carries wire information intelligence pulled from the AutoCAD Electrical drawings.

-  **Ribbon:** Panel tab ➤ Conduit Tools panel ➤ Conduit Reports drop-down





 **Toolbar:** Conduit Reports

 **Menu:** Panel Layout ► Conduit Marker Tools ► Wire/Conduit Routing Report

 **Command entry:** AEROUTINGREPORT

Decide if you want to run the report across selected drawings from the project, the active drawing, or selected conduit markers.



## Convert promis.e drawing files to AutoCAD Electrical

The promis.e® Conversion tool converts drawing files from promis.e to AutoCAD Electrical, while maintaining graphical elements. The drawing file data is converted into a format that can be edited and maintained in AutoCAD Electrical. You can convert a single drawing file or an entire project.

A log file is created in the same location as the drawing file or project to display all modifications. The log file name is either [drawing file name]\_cnv.log or [project name]\_cnv.log.

The conversion does the following:

- Inserts the WD\_M block if it does not exist in the drawing.
- Searches for Installation/Location drawing-wide defaults.
- Searches for blocks, cross-reference tables, and field boxes.
- Extracts a list of cross-reference symbols.
- Processes cable marker symbols, PLC modules, line entities, wire connection point, cross-reference tables, and block inserts.
- Copies footprint P\_TAG1 values to the associated nameplate.
- Renames terminal block names.
- Cleans up cross-reference inserts.
- Flips ladder line references to AutoCAD Electrical “smart.”

- Processes wire numbers.
- Inserts a copy of the WD\_PNLM block at 0,0.

---

**NOTE** You cannot see the command window messages during conversion unless you turn on the [command trace mode](#) on page 1686 debug tool.

---

## Convert promis-e drawings to AutoCAD Electrical drawings

Use to convert promis-e drawings to AutoCAD Electrical "smart" drawings.

- 1 Click Conversion Tools tab ► Tools panel ► Promis-e Conversion.



- 2 Select to convert the active drawing, multiple drawings in the active project, or an entire promis-e project.
- 3 Click OK.
- 4 If you selected Convert Multiple Drawings, Active Project select the drawings to process and click OK.
- 5 If you selected Convert promis-e Project select the promis-e project mapping file and click Open. Select the drawings to process and click OK. In the Convert promis-e Project dialog box:
  - Select the project to convert and click Open.
  - Select the installation codes to convert.
  - (Optional) Make any changes to project, installation, and drawing naming.
  - (Optional) Make any changes to the conversion setup, or symbol libraries.  
Make sure that the specified symbol library path contains the wd\_m.dwg block necessary for the conversion.
  - Enter the AutoCAD Electrical project path into the text box.
  - Click OK.

---

**NOTE** If the project file exists and is marked active, the conversion cannot finish. You must have another project open so AutoCAD Electrical can temporarily activate the other project, delete the active project (the one being overwritten), write the new .wdp file and reactivate the project.

---

## promis-e conversion

This tool converts drawing files from promis-e to AutoCAD Electrical. It examines the current symbol attributes on the drawing and maps them to the equivalent AutoCAD Electrical attribute to make them AutoCAD Electrical "smart."

 **Ribbon:** Conversion Tools tab ► Tools panel ► Promis-e Conversion.



 **Toolbar:** Conversion Tools

 **Menu:** Projects ► Conversion Tools ► Promis-e Conversion

 **Command entry:** AEP2E

<b>Convert Active Drawing Only</b>	Converts only the open and active drawing file from promis-e format to AutoCAD Electrical. Drawing files are not renamed or added to the project. This option is unavailable if the active drawing is unnamed.
<b>Convert Multiple Drawings, Active Project</b>	Converts drawing files that are already associated with the active project.
<b>Convert promis-e Project</b>	Selects an existing promis-e project and uses your AutoCAD Electrical project definitions to rename the folders and files to adhere to the names defined inside of promis-e. The drawing files are found in the promis-e structure.

## Convert promis-e project

Defines the conversion process from promis-e to AutoCAD Electrical. Once you click OK, it creates AutoCAD Electrical project definition file and folders, and then copies the drawing files into the new folders.

---

**NOTE** You cannot see the command window messages during conversion unless you turn on the [command trace mode](#) on page 1686 debug tool.

---

 **Ribbon:** Conversion Tools tab ► Tools panel ► Promis-e Conversion.



 **Toolbar:** Conversion Tools

 **Menu:** Projects ► Conversion Tools ► Promis-e Conversion

 **Command entry:** AEP2E

Select Convert promis-e Project and click OK. Select the promis-e mapping file and click Open.

### promis-e Projects

<b>Project Names</b>	Lists the promis-e projects defined in the project mapping file.
<b>Installation Codes</b>	Lists the installation codes defined in the project installation mapping file and the number of selected drawings.

The drawing count shows the number of drawings in the selected promis-e Project.

### AutoCAD Electrical Project

<b>Naming (Project, Installation, Drawing)</b>	Uses replaceable parameters to name projects (%P), installations (%I), drawing file names (%S), and folders. Replaceable parameters take on the values from the promis-e mapping files, however you can add additional characters.
<b>Conversion Setup</b>	Specifies pre- and post-processing script files to run against the entire project, and the AutoCAD Electrical support files to use (Default_wdtitle.wdl and Default.wdt). After you select the desired support file, it is renamed and placed in the same folder as the new project definition file (*.WDP). You also have

the option to save the command line error message to a log file.

#### Symbol Libraries

Opens the Project Properties ► Project Settings dialog box for selecting library search paths and icon menu files for the new project.

#### Conversion destination (base folder)

Specifies the AutoCAD Electrical project path. It is where the new project folder and drawing files are located. A path must be specified before the conversion can take place.

## Convert non-AutoCAD Electrical blocks

### Convert non-AutoCAD Electrical blocks

This utility takes non-AutoCAD Electrical blocks or graphics representing a symbol and replaces them with an AutoCAD Electrical block and transfers the attribute or text values to this new AutoCAD Electrical block.

- 1 Click Conversion Tools tab ► Tools panel ► Schematic Conversion



drop-down ► Convert to Schematic Component.

- 2 Pick your non-AutoCAD Electrical block containing attributes and text entities.
- 3 Pick an AutoCAD Electrical block from the Insert Component dialog box to use in its place.
- 4 Specify the insertion point.
- 5 From the Component Parent/Stand-Alone Annotation dialog box, assign text/attribute values to AutoCAD Electrical attribute names and click Done.

If your non-AutoCAD Electrical block has attributes, or you picked some text entities, the dialog box includes buttons to make it easier to assign your values to AutoCAD Electrical attributes.

### Finish mapping values from non-AutoCAD Electrical blocks

Use this utility to continue what you started with the Convert to Schematic Component tool. Use it if you did not finish mapping values from your non-AutoCAD Electrical block.

- 1 Click Conversion Tools tab ► Tools panel ► Map Attributes from Old



- 2 Select the block for additional attributes.
- 3 Optionally, select any non-AutoCAD Electrical block or text objects to map values to the AutoCAD Electrical attributes and click Done.

### Component annotation

These utilities replace non-AutoCAD Electrical blocks or graphics representing symbols with AutoCAD Electrical blocks, transferring the attribute or text values to the new AutoCAD Electrical block.

#### Convert to Schematic Component

 **Ribbon:** Conversion Tools tab ► Tools panel ► Schematic Conversion

drop-down ► Convert to Schematic Component.



 **Toolbar:** Conversion Tools

 **Menu:** Projects ► Conversion Tools ► Convert Drawing ► Convert to Schematic Component

 **Command entry:** AEBLK2SCH



#### Map Attributes from Old to New

 **Ribbon:** Conversion tab ► Tools panel ► Map Attributes from Old to





 **Toolbar:** Conversion Tools

 **Menu:** Projects > Conversion Tools > Convert Drawing > Map Attributes from Old to New

 **Command entry:** AEMAPATT

The left-side of the dialog box lists the text or attributes to map to an AutoCAD Electrical block while the right-side of the dialog box lists valid attribute fields to fill in.

---

**NOTE** Your options may differ depending on how you accessed the dialog box.

---

<b>Text value</b>	(available only if you select non-AutoCAD Electrical elements) Lists the available text values to assign to the attributes. All AutoCAD Electrical attributes for the block inserted are displayed in the Text Value list (if there is a block to map with existing attribute values).
<b>=</b>	(available only if you select non-AutoCAD Electrical elements) Transfers the text value to the selected attribute. Select a value from the list at the left and then pick the "="button next to the desired AutoCAD Electrical attribute.
<b>+</b>	(available only if you select non-AutoCAD Electrical elements) Appends the text value to the end of the current value for the selected attribute. Select a value from the list at the left and then pick the "+"button next to the target AutoCAD Electrical attribute.
<b>Pick</b>	Picks text or attribute objects from the drawing to assign to the AutoCAD Electrical attribute.
<b>Hide</b>	Makes the AutoCAD Electrical attribute visible or invisible.
<b>Drawing/Project</b>	Lists the installation, location, mount, and group annotations already used on the current drawing or project.

<b>Miscellaneous, Ratings, Positions, Pins</b>	Opens sub-dialog boxes for changing the attribute list to reflect ratings, pins, and so on.
<b>Delete original non-AutoCAD Electrical block</b>	Deletes a non-AutoCAD Electrical block once you map all the attributes.
<b>Delete picked text objects</b>	Replaces the picked text with the new AutoCAD Electrical attribute. To leave the selected text as is, then make sure that you turn this option off.
<b>Zoom window</b>	Defines an area of the drawing to fill the graphics window. Click to define the graphics window; the image is then zoomed to the area that you defined in the window.
<b>Zoom extents</b>	Zooms the selected block to the size of the graphics window.
<b>Zoom in</b>	Increases the magnification of the view so the blocks appear larger.
<b>Zoom out</b>	Decreases the magnification of the view so the blocks appear smaller.
<b>Pan</b>	Shifts the location of the view without changing the magnification. Use the Pan button to move the view in the graphics window in any direction planar to the screen.

## Convert text to an attribute

### Convert text to an attribute

This tool converts a text object into an attribute definition. The original text string becomes the default value of the attribute. For example, if you convert the text “120 VOLTS AC” to an attribute definition with a tag name of “RATING1”, the original text becomes the default value of the attribute.



- 1 Click Conversion Tools tab ► Tools panel ► Text Conversion



drop-down ► Convert Text to Attribute Definition.

- 2 Select the text entity to convert.
- 3 Define the attribute tag name. Enter a value or click the arrows to increment or decrement the displayed attribute tag name (for example, click the > button to increment the tag name “RATING5” to “RATING6”).
- 4 Click OK.

## Convert text to attribute definition

Converts a text object (that is not associated to a block) into an attribute definition. You can convert an attribute definition on a library symbol that becomes an attribute when the symbol drawing is inserted as a block into another drawing. For example, if you convert the text “120 VOLTS AC” to an attribute definition with a tag name of “RATING1”, the original text becomes the default value of the attribute.

 **Ribbon:** Conversion Tools tab ► Tools panel ► Text Conversion



drop-down ► Convert Text to Attribute Definition.



 **Toolbar:** Conversion Tools

 **Menu:** Components ► Attributes ► Convert Text to Attribute Definition

 **Command entry:** AETEXT2ATT

**Attribute tag name**

Specifies the attribute tag to assign to the selected text. Enter a value or click the arrows to increment or decrement the displayed attribute tag name (for example, click the > button to increment the tag name “RATING5” to “RATING6”).

## Convert text to a wire number

Converts a text object to a wire number compatible with AutoCAD Electrical.

- 1 Click Conversion Tools tab ► Tools panel ► Text Conversion



drop-down ► Convert Text to Wire Number.

- 2 Select the wire near the text to convert.
- 3 Select the text to convert.

## Convert Arrows

### Convert non-AutoCAD Electrical arrows

#### Convert non-AutoCAD Electrical arrows

Use the Convert Block to Source Arrow tool to replace a non-AutoCAD Electrical source arrow with a smart AutoCAD Electrical source arrow and map the information to the new AutoCAD Electrical source.

Use the Convert Block to Destination Arrow tool to replace a non-AutoCAD Electrical destination arrow with a smart AutoCAD Electrical destination arrow.

#### Convert a block to a source arrow

- 1 Click Conversion Tools tab ► Tools panel ► Schematic Conversion



drop-down ► Convert Block to Source Arrow.

- 2 Select your non-AutoCAD Electrical source block and/or any text related to it that you might want to map to the new AutoCAD Electrical source.
- 3 Select the wire end for the source arrow.
- 4 Define the Source Signal Code and click OK.
- 5 Define attribute values.

### Convert a block to a destination arrow

- 1 Click Conversion Tools tab ► Tools panel ► Schematic Conversion



drop-down ► Convert Block to Destination Arrow.

- 2 Select your non-AutoCAD Electrical destination block and/or any text related to it that you might want to map to the new AutoCAD Electrical destination.
- 3 Select the wire end for the destination arrow.
- 4 Define the Destination Signal Code and click OK.
- 5 Define attribute values.

## Overview of ECDS legacy conversion

For this conversion to be effective, AutoCAD Electrical must have information to swap AutoCAD Electrical type blocks with the blocks used on your ECDS drawings. It also must know how to map the values carried on each attribute on the blocks. This information is all supplied in an Access database file called WDVIAACMP.MDB.

### COMPSWSAP table

The COMPSWAP table tells AutoCAD Electrical how to swap blocks. It is simply a list of the blocks used on your ECDS drawings with a corresponding list of AutoCAD Electrical blocks. When the converter is run, AutoCAD Electrical looks for the block in the ECDS list and if it finds it, swaps it out for the block in the AutoCAD Electrical list.

If the origin for the AutoCAD Electrical block is different from the ECDS block, enter an XY Offset. To use multiple AutoCAD Electrical blocks to "build up" the ECDS symbol, use an available AutoCAD Electrical command \$C=wd\_via\_cv\_3unit, followed by the individual block names.

### ATTRMAP table

The ATTRMAP table tells AutoCAD Electrical how to map the information held on the attributes within each block. For each attribute used on the ECDS blocks, enter the AutoCAD Electrical attribute name in the next column to create the attribute map. Then when AutoCAD Electrical swaps out the blocks, the information carried on the individual attributes are not lost.

Notice the line mapping the attribute DESCRIPTION to DESC#. If you have blocks that contain multiple copies of the same attribute, for example, DESCRIPTION, you can map them to separate AutoCAD Electrical attributes such as DESC1, DESC2, DESC3. The "#" in the AutoCAD Electrical Attribute field, indicates that each time a DESCRIPTION attribute is found within a block, the AutoCAD Electrical attribute name should be incremented by 1 (starting with 1).

#### **IOATTRMAP table**

The IOATTRMAP table is the same as the ATTRMAP table but is used when a PLC block is swapped out. This accounts for some of the same attributes being mapped differently for PLC blocks than other blocks.

### **Convert using the ECDS to Electrical Database Builder**

The Access database file used for the ECDS to Electrical converter, WDVIACMP.MDB, can be modified directly with Microsoft Access or with the ECDS to Electrical Database Builder tool.

- 1 Enter AEECDs2ACADEDB at the command prompt.
- 2 Select the line within the list to edit.  
Individual values appear in the edit boxes.
- 3 Edit the necessary fields and click Update.
- 4 Add a new line to the database by filling in the fields and clicking Add.
- 5 Delete a line by selecting the line and clicking Delete.
- 6 Click OK.

### **Convert VIA ECDS or Jr. Project to AutoCAD Electrical**

If you used ECDS, you may have drawings you want to use with AutoCAD Electrical. AutoCAD Electrical provides a conversion tool that converts the intelligence of your ECDS drawings to the intelligence that AutoCAD Electrical expects.

 **Menu:** Projects ► Extras ► ECDS Legacy Conversion ► ECDS to Electrical Drawing Convert

 **Command entry:** AEECDs2ACADEDWG

## Project Options

### Existing VIA ECDS or Jr. Project (.VPJ)

Specifies the ECDS project name. Enter your ECDS project name or browse for it.

### AutoCAD Electrical Project (.WDP)

Specifies the AutoCAD Electrical project name. Enter an AutoCAD Electrical project name, either existing or new. If you are adding the drawings to an existing AutoCAD Electrical project make sure that you select that option, otherwise the .WDP project files are overwritten. The ECDS drawings are copied to another location before they are converted. A default location for the converted drawings is supplied, but you can enter any location. If the directory does not exist, AutoCAD Electrical creates it.

### Library path

Specifies the path to the schematic symbol library to use for the project. A default search path is supplied pointing to the Symbol library of converted symbols. You can include electrical, pneumatic, or other schematic libraries in the path. You can also include a series of paths for AutoCAD Electrical to search in order.

### Symbol1, Symbol2, Symbol3

Adds the path for a specific library of converted symbols. AutoCAD Electrical provides three libraries of converted symbols. These symbols look just like the older ECDS symbols but carry the expected AutoCAD Electrical attributes. The path to those symbols is added to your search path. Also, when you select your project to convert, AutoCAD Electrical reads the old ECDS PROJECT.CFG, and look for the Symbol library name. You can also type in any directory path you wish.

---

**NOTE** The libraries of converted symbols are supplied in a zip file called ConvSym.zip. Before running the conversion utility, unzip the libraries. Unzip pointing to your /Program Files/Autodesk/Acade .../Support directory but make sure that you use the folder names within the zip file. The zip file creates three subdirectories called "Converted Symbol1," "Converted Symbol2," and "Converted Symbol3."

---

### Drawing Options

Your drawings are copied to another directory and converted; the original drawings are not changed.

<b>Copy Directory</b>	Specifies the path for the converted drawings. If the directory does not exist it is created.
<b>Drawing Configuration</b>	Sets up the drawing defaults that are used for each drawing. The defaults are read from your ECDS PROJECT.CFG file, if possible.

AutoCAD Electrical presents a list of drawings in your ECDS project. Select the drawings you want to convert. AutoCAD Electrical then calls up each drawing, converts the intelligence and saves it. A log file is created named `projnam_cv.log` and saved in the same directory as the `.WDP` file. The log file contains information about any problems encountered in the conversion.

## Tagging and Linking Tools

### Use tagging and linking tools

Apply these manual tools to enable nonblocked geometry to be made AutoCAD Electrical-aware. The existing geometry stays in place and is unblocked. Key text entities are converted to attributes with user picks and are linked into a generic, nongraphical block insert. Wire connection attributes can also be merged into this generic block insert. The process to convert it from dumb text, circle, and line entities takes only moments to complete. The result appears as a fully functional AutoCAD Electrical-aware block insert.

Tagging results:

- The selected text entities are replaced with a template block file.
- The TAG attribute takes on the value of the converted text.
- The TAG attribute is set to fixed.
- The color of the TAG attribute is by layer. The attribute is the same layer as defined on the `WD_M` block.
- The TAG attribute takes on the same ACAD properties as the tagged text.

Linking results:

- The selected text entities are replaced with an AutoCAD Electrical attribute.
- Colors change to distinguish visually what was already converted as defined in the WD\_M block.
- Temporary lines display the link.

Wire Connection Results:

- Visual indicators (x) appear where the wire connection attributes were already applied.
- Wire connection attributes, terminal attributes, and terminal description attributes are added.
- The block definition is automatically modified during the attribute addition process.
- Terminal attribute colors change to distinguish visually what was already converted as defined in the WD\_M block.

Add Geometry Results:

- TAG1, TAG2, PLC TAG, and TAGSTRIP attributes are defined and selected first.
- The block definition is automatically modified.
- The color of the geometry changes by layer to distinguish visually what was already converted as defined in the WD\_M block.

## Tag and link components

You can do multiple tagging and linkages without exiting the commands.

---

**NOTE** This procedure uses schematic components, but the same procedure can be done using panel components.

---

### Initial set-up

- 1 Click Conversion Tools tab ► Tools panel ► Special Explode.
- 2 Explode any existing blocks.



It explodes attributes and blocks to geometry and text entities while maintaining the value previously defined in the attribute.

- 3 Select the wire layer from the grid to add wire lines to.  
The selected wire layer highlights in blue to indicate which layer is selected; the current wire layer highlights in gray.
- 4 Click Conversion Tools tab ► Tools panel ► Change/Convert Wire



Type drop-down ► Change/Convert Wire Type.

- 5 Click Pick and select wire lines from the drawing to add to a wire layer.
- 6 Click OK.

### Tag components

- 1 Click the Conversion Tools tab, Schematic panel, to access any of the schematic tagging commands.
- 2 Select the text entity to replace with the component TAG1 template block file.  
The selected text string highlights indicating what was selected for conversion.
- 3 Right-click to apply the tag.
- 4 (Optional) Tag any other text entities with the proper block file.
- 5 Right-click to exit the Tagging command. Right-click a few times before exiting, if necessary.

### Link components

- 1 Click the Conversion Tools tab, Attributes panel, to access any of the linking commands.
- 2 Select the existing tagged TAG1 block definition.
- 3 Right-click to apply the selection.
- 4 Select the text to link to the tagged attribute. The selected text properties are applied to the new attribute.  
Colors change to distinguish visually what was converted and temporary lines display the link.



- 5 Right-click to create the link.
- 6 (Optional) Link any other text entities to the proper attribute.
- 7 Right-click to exit the Linking command. Right-click a few times before exiting, if necessary.

### Add geometry and wire connections

- 1 Click Conversion Tools tab ► Tools panel ► Add Wire Connections.



- 2 Select the block to tie the wire connections to.
- 3 Select the endpoint of the wire or a position on a symbol. Press Shift, right-click, and select Endpoint from the menu to select the endpoint easily.
- 4 After you define the wire connection attribute, you can select the terminal text if the drawing contains the value. If not, continue with the next wire connection attribute.
- 5 Right-click to apply the selection.  
Visual indicators (x) appear where the wire connection attributes were already applied.
- 6 Repeat the selection for the other endpoint.
- 7 Right-click to exit the command. Right-click a few times before exiting, if necessary.



- 8 Click Conversion Tools tab ► Tools panel ► Add Geometry.
- 9 Select the block to add the geometry to.
- 10 Pick or window select the geometry to associate to the template block file.
- 11 Right-click to apply the selection.
- 12 Specify the insertion point.

### Special explode

Use this tool to explode attributes and blocks to geometry and text entities while maintaining the value previously defined in the attributes. You can take advantage of the tagging tools to modify the text entities to attributes and the linking tools to make various blocks.

---

**NOTE** Use AutoCAD Explode to convert Mtext to normal text for tagging and linking.

---

 **Ribbon:** Conversion Tools tab ► Tools panel ► Special Explode.



 **Toolbar:** Conversion Tools



 **Menu:** Projects ► Conversion Tools ► Special Explode

 **Command entry:** AEEXPLODE

Select the block to explode into separate text entities and geometry.

## Tag schematic

Use these tools to convert text entities into an attributed block. Through the insertion of a template block, you have control over which attributes are inserted and visible. All necessary attribute definitions are automatically placed. During the tagging process, the text entity is removed and replaced with a template block file that contains multiple attributes used in AutoCAD Electrical.

Click Conversion Tools tab ► Schematic panel. Select one of the schematic tagging commands from the list.

Click any of the tagging tools. Select the text entity to replace with the component TAG1 template block file, and right-click to apply the tag.



**Tag Schematic Component**

Makes selected text entities an attributed block file with the TAG1 attribute visible. The template block file (HDV1\_CONVERT.DWG or VDV1\_CONVERT.DWG depending on the drawing properties) contains attributes for a schematic component.



**Tag PLC**

Makes selected text entities an attributed PLC address associated to a PLC tag. The template block file (PLCIO\_ADDR\_CONVERT.DWG, PLCIO\_CONVERT.DWG, PLCIO\_V\_ADDR\_CON-

VERT.DWG, or PLCIO\_V\_CONVERT.DWG depending on the drawing properties) contains attributes found useful for PLC addressing. After the addressing is defined on the block, select a PLC Tag or place one into the symbol definition for use with AutoCAD Electrical.



**Tag Child**

Makes selected text entities an attributed block file with the TAG2 attribute visible. The template block file (HDV2\_CONVERT.DWG or VDV2\_CONVERT.DWG depending on the drawing properties) contains attributes used for a child component.



**Tag Child - N.O.**

Makes selected text entities an attributed block file with the TAG2 attribute visible. The template block file (HDV21\_CONVERT.DWG or VDV21\_CONVERT.DWG depending on the drawing properties) contains attributes used for a child normally open contact component.



**Tag Child - N.C.**

Makes the selected text entities an attributed block file with the TAG2 attribute visible. The template block file (HDV22\_CONVERT.DWG or VDV22\_CONVERT.DWG depending on the drawing properties) contains attributes used for a child normally closed contact component.



**Tag Child - Form C**

Makes the selected text entities an attributed block file with the TAG2 attribute visible. The template block file (HDV23\_CONVERT.DWG or VDV23\_CONVERT.DWG depending on the drawing properties) contains attributes used for a child Form C contact component.



**Tag Schematic Terminal - Terminal Number**

Makes the selected text entities an attributed block file with the TAGSTRIP and TERM01 attribute visible. The template block file (HT0T\_CONVERT.DWG or VT0T\_CONVERT.DWG depending on the drawing properties) contains attributes used for a terminal block component containing a terminal number.



#### **Tag Schematic Terminal - Wire Number**

Makes the selected text entities an attributed block file with the TAGSTRIP and WIRENO attribute visible. The template block file (HT0W\_CONVERT.DWG or VT0W\_CONVERT.DWG depending on the drawing properties) contains attributes used for a terminal block component containing a wire number as the terminal number.



#### **Tag Schematic Terminal - Wire Number Change**

Makes the selected text entities an attributed block file with the TAGSTRIP and TERM01 attribute visible. The template block file (HT1T\_CONVERT.DWG or VT1T\_CONVERT.DWG depending on the drawing properties) contains attributes used for a terminal block component that changes the wire number. It creates a terminal number block that has a different wire number for each wire connected to it.

## **Tag panel**

Use these tools to convert text entities into an attributed block file. Through the insertion of a template block, you have control over which attributes are inserted and visible. All necessary attribute definitions are automatically placed. During the tagging process, the text entity is removed and replaced with a template block file that contains multiple attributes used in AutoCAD Electrical.

Click Conversion Tools tab ► Panel panel. Select one of the panel tagging commands from the list.

Click any of the tagging tools. Select the text entity to replace with the component TAG1 template block file and right-click to apply the tag.



#### **Tag Panel Component**

Makes selected text entities an attributed block file with the P\_TAG1 attribute visible. The template block file (ACE\_P\_TAG1\_CONVERT.DWG) contains attributes for a panel component.



#### **Tag Nameplate**

Makes selected text entities an attributed block file with the DESC1-3 attributes visible. The template block file (ACE\_NP\_CONVERT.DWG) contains attributes used in nameplate symbols. If the description text strings were previously defined as attributes on an AutoCAD Electrical

panel component block definition, the attribute values on the panel component are hidden and the nameplate attributes DESC1-3 are added and made visible.



**Tag Panel Terminal - Terminal Number**

Makes selected text entities an attributed block file with the TERM01 terminal number attribute visible. The template block file (ACE\_TERM\_CONVERT.DWG) contains attributes for terminal numbers.



**Tag Panel Terminal - Wire Number**

Makes selected text entities an attributed block file with the WIRENO wire number attribute visible. The template block file (ACE\_TERMW\_CONVERT.DWG) contains attributes for panel terminal symbols.

## Link

Use these tools to associate nonblocked text to previously placed blocks. Through the modification of a template block, you have control over which attributes are inserted and visible. All necessary attribute definitions are placed using the properties of the existing text entities, such as justification, height, and location. If multiple template block files are selected, the value of the text is added to the previously defined template block attributes as hidden attributes and the text is not removed.

Click Conversion Tools tab ► Attributes panel. Select one of the linking commands from the list.

Click any of the linking tools. Select the existing tagged TAG1 block definition, and right-click to apply the selection. Select the text to link to the tagged attribute. The selected text properties are applied to the new attribute. Right-click to create the link.



**Link Description**

Links simple text as Description 1-3 attributes on an AutoCAD Electrical block file. You can link them as description attributes to one or more existing template block definitions. During the conversion process, the text entity is removed and replaced with the next available description attribute, up to 3.



**Link PLC Address Description**

Links simple text to a PLC address attribute as PLC I/O address description attributes. During the conversion process, the text entity is removed and replaced with the next available PLC address description attribute, up to 5.



**Link Terminal Number**

Links simple text to a TAGSTRIP attribute as a terminal number attribute on an AutoCAD Electrical terminal block symbol. During the conversion process, the text entity is removed and replaced with the TERM01 or WIRENO attribute.



**Link Manufacturer**

Links simple text as manufacturer attributes on an AutoCAD Electrical block file. The entity value is used as the Manufacturer value for one or more template block definitions. If only one template block is selected for the link, the text entity is removed and replaced with the Manufacturer attribute.



**Link Catalog Number**

Links simple text as Catalog Number attributes on an AutoCAD Electrical block file. The entity value is used as the Catalog Number value for one or more template block definitions. If only one template block is selected for the link, the text entity is removed and replaced with the Catalog Number attribute.



**Link Location Code**

Links simple text as Location attributes on an AutoCAD Electrical block file. The entity value is used as the Location value for one or more template block definitions. If only one template block is selected for the link, the text entity is removed and replaced with the Location attribute.



**Link Installation Code**

Links simple text as Installation attributes on an AutoCAD Electrical block file. The entity value is used as the Installation value for one or more template block definitions. If only one template block is selected for the link, the text entity is removed and replaced with the Installation attribute.



### Link Split Tag

Links another string of text to a tag attribute, creating a split tag. Create the device Tag using the TAG1, TAG, or P\_TAG1 attributes. Then use this tool to select the existing TAG attribute on the drawing and link another string of text, creating a split tag situation. The first TAG becomes the Part1 of the split tag while the linked portion becomes the Part2 of the split tag.



### Link User

Links simple text (that is not an attribute definition or part of geometry) as User (01-99) attributes on an AutoCAD Electrical block file. The entity value is used as the user value for one or more template block definitions. If only one template block is selected for the link, the text entity is removed and replaced with the user attribute, up to 99. Window selection is allowed.



### Link Rating

Links simple text as Rating 1-12 attributes on an AutoCAD Electrical block file. The entity value is used as the rating value for one or more template block definitions. If only one template block is selected for the link, the text entity is removed and replaced with the rating attribute, up to 12.



### Link Item Number

Links simple text as an Item Number attribute on an AutoCAD Electrical Panel block file. During the conversion process, the text entity is removed and replaced with the Item Number attribute (P\_ITEM).



### Show Links

Displays links for a selected block.





### Un Link

Unlinks a selected linked attribute from a symbol.

## Add geometry

Use this tool to add AutoCAD geometry to a template block file to be created as part of a unique block instance. It creates a block definition with the newly added geometry. You can later create a block file if the block is exploded.

 **Ribbon:** Conversion Tools tab ► Tools panel ► Add Geometry.

 **Toolbar:** Link Schematic  
**Menu:** Projects ► Conversion Tools ► Link Schematic ► Add Geometry  
**Command entry:** AEGEOMETRY

Select the block to add the geometry to. Pick or window select the geometry to associate to the template block file, and right-click to apply the selection. Specify an insertion point.

## Add wire connections

Use this tool to add wire connection attributes to the existing tagged block file. Select line endpoints or geometry to add the appropriate wire connection attributes to. A new block definition is created with the newly added wire connections. You can later create a block file if the block is exploded.

**Ribbon:** Conversion Tools tab ► Tools panel ► Add Wire Connections.



 **Toolbar:** Link Schematic  
**Menu:** Projects ► Conversion Tools ► Link Schematic ► Add Wire Connections  
**Command entry:** AEWIRECONN

Select the block TAG or PLC Address to tie the wire connection to. Select the wire end or pick near the selected block to select a location if no wire exists. If you picked a location, the Wire Direction dialog box displays. Select where you want the wire to come from: above, right, below, or left of the selected block. Right-click to apply the wire connection.

## Show links



Use this tool to select the tagged template block file and display everything (such as description, location, manufacturer, and catalog number codes) that has been linked to it.



 **Ribbon:** Conversion Tools tab ► Attributes panel ► Show Links.



 **Toolbar:** Link Schematic

 **Menu:** Projects ► Conversion Tools ► Link Schematic ► Show Links

 **Command entry:** AESHOWLINK

Select a single link by picking or multiple links by windowing. Temporary line graphics show what was previously linked.

## Un link

Use this tool to select an existing linked attribute and unlink the attribute from the symbol, changing the attribute to AutoCAD text.



 **Ribbon:** Conversion Tools tab ► Attributes panel ► Un-Link.



 **Toolbar:** Link Schematic

 **Menu:** Projects ► Conversion Tools ► Link Schematic ► Un Link

 **Command entry:** AEUNLINK

Select the link to remove; the link between the attributes and the block it is associated to is removed.

## Overview of block/attribute mapping

You can perform drawing-wide or project-wide block replacements using a user-defined Microsoft Excel spreadsheet and an AutoCAD Electrical-aware symbol library that it references. The spreadsheet performs a lookup for each block name and finds the corresponding new block. Each new block drawing is pulled from the AutoCAD Electrical symbol library and inserted (scaled and rotated as required) in the drawing. The spreadsheet is checked to copy the old attribute values to the appropriate new names on the newly inserted block. This process continues across the drawing, and terminates when no more

block names remain. It automatically continues to the next drawing if project-wide mode is selected.

The mapping spreadsheet has two parts: Attribute mapping defaults and Block name mapping. Each section is a sheet within the spreadsheet and must follow a defined column format. The sheets must be in order, where sheet 1 defines the attribute mapping and sheet 2 defines the block mapping.

<b>Attribute mapping defaults</b>	General mapping of old attribute names to new attribute names so that the old values on the blocks can be copied to the swapped AutoCAD Electrical-smart block.
<b>Block name mapping</b>	Maps existing specific or wild-carded block names to the new AutoCAD Electrical block to use during the block instance swap. Each row of this spreadsheet is a mapping record for an old name to a new name swap.

#### **Attribute mapping sheet format**

<b>Column A / Old Attribute Name</b>	Attribute tag found on the legacy, non-AutoCAD Electrical block insert. Wildcards and AutoLISP-style punctuation for wildcards are supported.
<b>Column B / AcadE Attribute Name</b>	Attribute tag name found on the AutoCAD Electrical block insert. Wildcards and AutoLISP-style punctuation for wildcards are supported.

#### **Block name mapping sheet format**

<b>Column A / Old Block Name</b>	Legacy, non-AutoCAD Electrical block insert name. Wildcards and AutoLISP-style punctuation for wildcards are supported.
<b>Column B / AcadE Block Name</b>	AutoCAD Electrical block name to use as a replacement for all instances of the block query match on columns A and C.
<b>Column C / Filtering Expression</b>	Optional. AutoLISP expression, or attribute definition, along with column A are what the program uses to query the table to find the correct mapping entry for a given block name to swap.

<b>Column D / Scale Multiplier</b>	If blank, the new block swaps in at the same scale as the existing block it replaces. If this field is not blank, the swapped block is scaled up or down per the multiplier value of the field.
<b>Column E / X-Y Offset</b>	If blank, the new block swaps in at the same XY coordinate as the existing block it replaces. If not blank and in the format of a coordinate pair, the swapped block inserts offset from the origin of the original block by this XY amount.
<b>Column F / Attribute name overrides</b>	Defines specific attribute Old=New mapping that is not defined in sheet 1 or is to override what is found in sheet 1. Multiple entries in this field are supported with this syntax: Old1=New1;Old2=New2.
<b>Column G / Attribute Value Overrides</b>	Defines specific attribute values to insert into the newly swapped attributes. Multiple entries in this field are supported with this syntax: New1=val1;New2=val2. An entry of "New1=" blanks out that attribute value.

The block replacement process generates a log file of the results. The log file ({projectname}\_cnv.log) is created in the same folder as the .wdp project file. The following conditions are reported:

- Problem finding/opening mapping spreadsheet
- Problem inserting WD\_M block (if not already present)
- Legacy block name not mapped to an AutoCAD Electrical block
- AutoCAD Electrical block not found in library search path
- Problem inserting AutoCAD Electrical block
- Legacy attribute name not mapped

### Map block values using a user-defined spreadsheet

---

**NOTE** A user-defined spreadsheet is required for this tool. Refer to the "Learn about block/attribute mapping" file for help on creating the spreadsheet if you do not already have one created.

---

- 1 Click Conversion Tools tab ► Tools panel ► Block Replacement



drop-down ► Block Replacement.

- 2 Select to run the block replacement for the entire project, the active drawing, or a selected component on the active drawing.
- 3 Click OK.
- 4 On the Select Mapping Spreadsheet dialog box, select the spreadsheet to use for mapping the blocks and attributes.
- 5 Click Open.

If you select an existing spreadsheet the block replacement automatically begins. If the spreadsheet file does not exist you are presented with the option to create the spreadsheet framework for the block/attribute mapping.

If a spreadsheet was not found, on the Spreadsheet Not Found dialog box, click OK to run through the drawing set of the active project. Fill in a blank spreadsheet with extracted block names and attributes. Only the first column of each of the sheets are filled in. You can then add the block/attribute mapping information and then rerun the command using the new spreadsheet.

## Block replacement

Performs drawing-wide and project-wide block replacements using a user-defined spreadsheet. It automatically maps the non-AutoCAD Electrical block inserts of the unconverted drawing and attributes to appropriate AutoCAD Electrical-smart component symbols drawn from a symbol library.

 **Ribbon:** Conversion Tools tab ► Tools panel ► Block Replacement



drop-down ► Block Replacement.



 **Toolbar:** Conversion Tools

 **Menu:** Projects ► Conversion Tools ► Block Replacement

 **Command entry:** AEBLOCKREPLACE

Select to run the block replacement on the entire project, the active drawing, or a single symbol on the active drawing.



## Overview of power check tools

You can add information to your schematic components to indicate power source and load values using the supplied Power Check tools. Once these values are added, you can run the Power Load Check Report to scan the wire interconnections and report if there is too much load on a given power source.

There are 3 tools to use for checking power source/load:

### **Add/Edit Power Source/Load Levels**

Marks a component with a power source and load value. The value is added to an AutoCAD Electrical connection attribute. This dialog box contains a list of available connection points. If you select near the connection point for the power value it is preselected in the dialog box. Enter the power source and load value and an optional units value. These values are saved on the connection point as invisible xdata.

### **Set Pass Power**

Marks a component with a PASSPWR flag. The PASSPWR flag instructs the Power Report to pass through the marked component when calculating the load on a given source. If a component carries the PASSPWR flag the Power Report program passes through the component and continue looking for load values on the network

### **Power Load Check Report**

Looks for any components assigned as a power source and then follows any wires connected to that terminal. When a load is hit, it stops reading on that wire segment and does not search past the load. For

example, if you apply a supply value to the left power bus on a ladder, there are a bunch of pilot lights and relay coils in the ladder. AutoCAD Electrical goes down the left bus and checks each connected rung. It reads through contact and terminals, but when it hits a load on a rung, it accumulates the load value (if present) and stops going any further on that rung. The utility still checks the other rungs tied to the left-hand bus and attempts to find more loads.

### Tip: Adding Xdata to library symbols before insertion

You can add the Xdata on the library symbol before inserting it. If a drawing already contains that block, use the Update Block option before running the report. Open the library symbol and use the Xdata Editor to add Xdata directly onto the appropriate TERM## attribute. The following xdata can be added at the library level:

- Source - VIA\_WD\_PWR\_SRC
- Load - VIA\_WD\_PWR\_LOAD
- Unit - VIA\_WD\_PWR\_UNIT
- Potential - VIA\_WD\_POTENTIAL

### Set power source/load value

This utility marks a component with a power source and load value. A related routine, when invoked, then scans the wire interconnections and reports if there is too much load on a given power source.

 **Ribbon:** Schematic tab ► Power Check Tools panel ► Add/Edit

Source/Load. 



 **Toolbar:** Power Check

 **Menu:** wires ► Wire Numbers Miscellaneous ► Power Check ► Add/Edit Power Source/Load Levels

 **Command entry:** AEPOWERLOADLEVELS



Select the component for the power source or load value. The value is added to an AutoCAD Electrical connection attribute. This dialog box contains a list of available connection points. If you select near the connection point for the power value it is preselected in the dialog box. Enter the power source and load value and an optional units value. These values are saved on the connection point as invisible xdata.

---

**NOTE** As you add these power source or load values, think of AutoCAD Electrical tracing through these components to see what the load is on the power source. Pick the terminal to which the value is added accordingly.

---

### Source/load assignment

<b>Source/Load</b>	Indicates to set the source or load value.
<b>Value</b>	Specifies the source or load value to save on the connection point.
<b>Units</b>	(Optional) Specifies the units for the source or load value. Select from the drop-down list to specify the units.

### Potential assignment

Optional for voltage level mismatch checks. Select from the drop-down list to specify the potential value.

### Set pass power

This utility marks a component with a PASSPWR flag. The PASSPWR flag instructs the Power Report to pass through the marked component when calculating the load on a given source. If a component carries the PASSPWR flag the Power Report program passes through the component and continue looking for load values on the network.

---

**NOTE** Certain components do not need a PASSPWR flag (such as terminals and contacts) since they are automatically 'passed' through.

---

 **Ribbon:** Schematic tab ► Power Check Tools panel ► Pass Component.



 **Toolbar:** Power Check

 **Menu:** Wires ► Wire Numbers Miscellaneous ► Power Check ► Mark Component to Pass Power

 **Command entry:** AEPASSPWR

Each selected component is displayed in the list. If the component already carries the PASSPWR flag, a \* appears next to the tag. To set or unset the PASSPWR flag, click the tag of the component in the list.

## Power source/load report

Once a component is marked with a power source and load value, this utility scans the wire interconnections and reports if there is too much load on a given power source.

 **Ribbon:** Schematic tab ► Power Check Tools panel ► Load Check



 **Toolbar:** Power Check

 **Menu:** Wires ► Wire Numbers Miscellaneous ► Power Check ► Power Load Check Report

 **Command entry:** AEPOWERLOADREPORT

Select to run the report on the project, selected components in the active drawing, or all components in the active drawing. You can also select to redisplay the last Power Check report.

## Overview of pneumatic tools



Use the Insert Pneumatic Component tool on the Schematic tab ► Insert Components panel to insert your Pneumatic symbols. Then use all of the AutoCAD Electrical drafting and editing tools to modify the pneumatic layout, including Stretch, Trim and Scoot.

The Icon Menu provides easy access to pneumatic library symbols. The pneumatic symbol library consists of all the pneumatic symbols and is found at

- **Windows XP:** \Documents and Settings\All Users\Documents\Autodesk\Acade {version}\Libs\pneu\_iso125

- **Windows Vista, Windows 7:** \Users\Public\Documents\Autodesk\Acade {version}\Libs\pneu\_iso125

### Recommended Settings for drawing pneumatic diagrams

Setting	Value	Where this can be set
Ladder Orientation	Horizontal	Drawing Properties ► Drawing Format

## Insert component

This icon menu can be modified, expanded, or replaced with a custom menu. You can change the default icon menu using the Library and Icon Menu Paths section of the [Project properties: project settings tab](#) on page 204. Use the Icon Menu Wizard to modify the menu. The default icon menu can also be redefined in *wd.env*. Add entry "WD\_MENU" for schematic icon menu and "WD\_PMENU" for panel layout icon menu.

### Insert Component

 **Ribbon:** Schematic tab ► Insert Components panel ► Insert Components

drop-down ► Icon Menu.



 **Toolbar:** Main Electrical

 **Menu:** Components ► Insert Component

 **Command entry:** AECOMPONENT

### Multiple Insert (Icon Menu)

 **Ribbon:** Schematic tab ► Insert Components panel ► Multiple Insert

drop-down ► Multiple Insert (Icon Menu).



 **Toolbar:** Main Electrical

 **Menu:** Components ► Multiple Insert ► Multiple Insert (Icon Menu)

 **Command entry:** AEMULTI

---

**NOTE** This dialog box is also accessed when inserting Pneumatic, Hydraulic, or P&ID components; in-line wire labels; stand-alone cross-reference symbols; cable markers; and saved circuits.

---

Select an icon picture or the component type from the Menu tree structure. The main menu in the tree structure is displayed as the menu heading just above the menu tree structure.

<b>Tabs</b>	<ul style="list-style-type: none"><li>■ Menu: Changes the visibility of the Menu tree view.</li><li>■ Up one level: Displays the menu that is one level before the current menu in the Menu tree view. This option is unavailable if the main menu is selected in the Menu tree view.</li><li>■ Views: Changes the view display for the Symbol Preview window and Recently Used window. The current view option is indicated with a check mark. Options include: Icon with text, Icon only or List view.</li></ul>
<b>Menu</b>	The tree structure is created by reading the icon menu file (.dat). The tree structure is based on the arrangement order of submenus defined in the .dat file.
<b>Symbol Preview window</b>	Displays the symbol and submenu icons corresponding to the menu or the submenu selected in the Menu tree structure. Clicking on the icon performs one of the following functions based on the icon properties as defined by the .dat file: <ul style="list-style-type: none"><li>■ Inserts the symbol or circuit onto the drawing</li><li>■ Executes a command</li><li>■ Displays a submenu</li></ul> <hr/> <p><b>NOTE</b> When you move the cursor over an icon, the icon name and block/circuit/command name display as tooltip information.</p> <hr/>
<b>Recently Used</b>	Displays the last components inserted during the current editing session; the most recently used icon displays in the top. This list follows the view options setting in the symbol preview window (icon only, icon with text or list view). The total number of icons displayed depends on the value specified in the Display edit box.
<b>Display</b>	Specifies the number of icons to display in the Recently Used list box. Enter integer numbers only; the default value is 10.

<b>Vertical/Horizontal</b>	Inserts the icon using a vertical or horizontal orientation. This value is opposite the default ladder rung orientation for the drawing.
<b>No edit dialog</b>	Turns off the Insert/Edit Component dialog box when inserting symbols onto the drawing. To add component detail later, click the Edit Component tool, and select the component to edit.
<b>No tag</b>	Inserts the component, untagged (that is, without assigning a unique Component Tag). The untagged value that displays is the TAG1/TAG2 default value for the component. To add component detail later, click the Edit Component tool, and select the component to edit.
<b>Always display previously used menu</b>	Indicates to display the previously used menu each time you open the Insert Component dialog box. For example, if you insert a push button from the Push Buttons menu, the next time you open the Insert Component dialog box the Push Button menu displays by default.
<b>Scale schematic</b>	Specifies the component block insertion scale. This defaults to the value set in the Drawing Properties ► Drawing Format dialog box. Once set, this value is remembered until reset or until the drawing editing session ends.
<b>Scale panel</b>	Specifies the footprint insertion scale. This defaults to the value set in the Drawing Properties ► Drawing Format dialog box. Once set, this value is remembered until reset or until the drawing editing session ends.
<b>Type it</b>	Manually type in the component block to insert.
<b>Browse</b>	Browses to and selects the component to insert.

## **Right-click menus**

### **Options for the Menu tree structure view**

Right-click on the main menu or submenu in the Menu tree structure view to display the following options:

- **Expand/Collapse:** Toggles the visibility of the menus.

- Properties: Opens a Properties dialog box to view the existing menu or submenu properties like the menu name, image, or submenu title. Use the Icon Menu Wizard to change any menu properties.

#### Options for the Symbol Preview window

Right-click an icon or in empty space in the Symbol Preview window to display the following options:

- View: Changes the view display for the Symbol Preview window and Recently Used window. The current view option is indicated with a check mark. Options include: Icon with text, Icon only or List view.
- Properties: (available for icons only) Opens a Properties dialog box to view the existing symbol icon properties like the icon name, image, block names and so on. Use the Icon Menu Wizard to change any icon properties.

#### Pneumatic, Hydraulic, and P&ID icon menus

The Menu tree structure displays the symbols for the selected component type (pneumatic, hydraulic, or P&ID). The Insert Pneumatic Component, Insert Hydraulic Component, and Insert P&ID Component tools are accessed from the Schematic tab ► Insert Components panel on the ribbon or the Extra Library toolbar.



Insert Pneumatic Component



Insert Hydraulic Component



Insert P&ID Component

# Insert hydraulic components

## Insert hydraulic components

Use the Insert Hydraulic Component tool to insert a component into the drawing.

- 1 Click Schematic tab ► Insert Components panel ►  ► Insert



Hydraulic Component.

- 2 On the Insert Component dialog box, select the starting orientation for the component: horizontal or vertical.
- 3 (Optional) If you want to turn off the Insert/Edit Component dialog box when inserting symbols onto the drawing, select No edit dialog box.
- 4 (Optional) If you want to insert the component, untagged (for example, without assigning a unique Component Tag) select No tag. The untagged value that displays is the TAG1/TAG2 default value of the component.
- 5 Select the component to insert (such as Filters ► Centrifugal) from the Symbol Preview window.  
The Recently Used column displays components inserted during the current editing session. You can also select the component to insert from this list.
- 6 Specify the insertion point in the drawing.  
The orientation of the symbol tries to match the underlying wire. The wire breaks automatically if the symbol lands on it.
- 7 In the Insert/Edit Component dialog box, annotate the component.
- 8 Click OK.

### Recommended Settings for drawing Hydraulic diagrams

Setting	Inch Unit	Metric Unit	Where this can be set
Grid Size	0.125	2.5	Tools ► Drafting Settings
Snap	0.125	2.5	Tools ► Drafting Settings

Scale Factor	1	20	Drawing Properties ► Drawing Format
Ladder Orientation	Horizontal	Horizontal	Drawing Properties ► Drawing Format

## Insert component

This icon menu can be modified, expanded, or replaced with a custom menu. You can change the default icon menu using the Library and Icon Menu Paths section of the [Project properties: project settings tab](#) on page 204. Use the Icon Menu Wizard to modify the menu. The default icon menu can also be redefined in *wd.env*. Add entry "WD\_MENU" for schematic icon menu and "WD\_PMENU" for panel layout icon menu.

### Insert Component

 **Ribbon:** Schematic tab ► Insert Components panel ► Insert Components

drop-down ► Icon Menu.



 **Toolbar:** Main Electrical

 **Menu:** Components ► Insert Component

 **Command entry:** AECOMPONENT

### Multiple Insert (Icon Menu)

 **Ribbon:** Schematic tab ► Insert Components panel ► Multiple Insert

drop-down ► Multiple Insert (Icon Menu).



 **Toolbar:** Main Electrical

 **Menu:** Components ► Multiple Insert ► Multiple Insert (Icon Menu)

 **Command entry:** AEMULTI



---

**NOTE** This dialog box is also accessed when inserting Pneumatic, Hydraulic, or P&ID components; in-line wire labels; stand-alone cross-reference symbols; cable markers; and saved circuits.

---

Select an icon picture or the component type from the Menu tree structure. The main menu in the tree structure is displayed as the menu heading just above the menu tree structure.

<b>Tabs</b>	<ul style="list-style-type: none"><li>■ Menu: Changes the visibility of the Menu tree view.</li><li>■ Up one level: Displays the menu that is one level before the current menu in the Menu tree view. This option is unavailable if the main menu is selected in the Menu tree view.</li><li>■ Views: Changes the view display for the Symbol Preview window and Recently Used window. The current view option is indicated with a check mark. Options include: Icon with text, Icon only or List view.</li></ul>
<b>Menu</b>	The tree structure is created by reading the icon menu file (.dat). The tree structure is based on the arrangement order of submenus defined in the .dat file.
<b>Symbol Preview window</b>	Displays the symbol and submenu icons corresponding to the menu or the submenu selected in the Menu tree structure. Clicking on the icon performs one of the following functions based on the icon properties as defined by the .dat file: <ul style="list-style-type: none"><li>■ Inserts the symbol or circuit onto the drawing</li><li>■ Executes a command</li><li>■ Displays a submenu</li></ul>
	<hr/> <p><b>NOTE</b> When you move the cursor over an icon, the icon name and block/circuit/command name display as tooltip information.</p> <hr/>
<b>Recently Used</b>	Displays the last components inserted during the current editing session; the most recently used icon displays in the top. This list follows the view options setting in the symbol preview window (icon only, icon with text or list view). The total number of icons displayed depends on the value specified in the Display edit box.
<b>Display</b>	Specifies the number of icons to display in the Recently Used list box. Enter integer numbers only; the default value is 10.

<b>Vertical/Horizontal</b>	Inserts the icon using a vertical or horizontal orientation. This value is opposite the default ladder rung orientation for the drawing.
<b>No edit dialog</b>	Turns off the Insert/Edit Component dialog box when inserting symbols onto the drawing. To add component detail later, click the Edit Component tool, and select the component to edit.
<b>No tag</b>	Inserts the component, untagged (that is, without assigning a unique Component Tag). The untagged value that displays is the TAG1/TAG2 default value for the component. To add component detail later, click the Edit Component tool, and select the component to edit.
<b>Always display previously used menu</b>	Indicates to display the previously used menu each time you open the Insert Component dialog box. For example, if you insert a push button from the Push Buttons menu, the next time you open the Insert Component dialog box the Push Button menu displays by default.
<b>Scale schematic</b>	Specifies the component block insertion scale. This defaults to the value set in the Drawing Properties ► Drawing Format dialog box. Once set, this value is remembered until reset or until the drawing editing session ends.
<b>Scale panel</b>	Specifies the footprint insertion scale. This defaults to the value set in the Drawing Properties ► Drawing Format dialog box. Once set, this value is remembered until reset or until the drawing editing session ends.
<b>Type it</b>	Manually type in the component block to insert.
<b>Browse</b>	Browses to and selects the component to insert.

### **Right-click menus**

#### **Options for the Menu tree structure view**

Right-click on the main menu or submenu in the Menu tree structure view to display the following options:

- **Expand/Collapse:** Toggles the visibility of the menus.

- Properties: Opens a Properties dialog box to view the existing menu or submenu properties like the menu name, image, or submenu title. Use the Icon Menu Wizard to change any menu properties.

#### Options for the Symbol Preview window

Right-click an icon or in empty space in the Symbol Preview window to display the following options:

- View: Changes the view display for the Symbol Preview window and Recently Used window. The current view option is indicated with a check mark. Options include: Icon with text, Icon only or List view.
- Properties: (available for icons only) Opens a Properties dialog box to view the existing symbol icon properties like the icon name, image, block names and so on. Use the Icon Menu Wizard to change any icon properties.

#### Pneumatic, Hydraulic, and P&ID icon menus

The Menu tree structure displays the symbols for the selected component type (pneumatic, hydraulic, or P&ID). The Insert Pneumatic Component, Insert Hydraulic Component, and Insert P&ID Component tools are accessed from the Schematic tab ► Insert Components panel on the ribbon or the Extra Library toolbar.



Insert Pneumatic Component



Insert Hydraulic Component



Insert P&ID Component

# Insert P&ID components

## Insert P&ID components

Use the Insert P&ID Component tool to insert a component into the drawing.

- 1 Click Schematic tab ► Insert Components panel ►  ► Insert

P&ID Components.



- 2 In the Insert Component dialog box, select the starting orientation for the component: horizontal or vertical.
- 3 (Optional) If you want to turn off the Insert/Edit Component dialog box when inserting symbols onto the drawing, select No edit dialog box.
- 4 (Optional) If you want to insert the component, untagged (for example, without assigning a unique Component Tag), select No tag. The untagged value that displays is the TAG1/TAG2 default value of the component.
- 5 Select the component to insert from the Symbol Preview window.  
The Recently Used column displays components inserted during the current editing session. You can also select the component to insert from this list.
- 6 Specify the insertion point in the drawing.  
The orientation of the symbol tries to match the underlying wire. The wire breaks automatically if the symbol lands on it.
- 7 In the Insert/Edit Component dialog box, annotate the component.
- 8 Click OK.

### Recommended Settings for drawing P & ID diagrams

Setting	Inch Unit	Metric Unit	Where this can be set
Grid Size	0.125	2.5	Tools ► Drafting Settings
Snap	0.125	2.5	Tools ► Drafting Settings

Scale Factor	1	20	Drawing Properties ► Drawing Format
Ladder Orientation	Vertical	Vertical	Drawing Properties ► Drawing Format

## Insert component

This icon menu can be modified, expanded, or replaced with a custom menu. You can change the default icon menu using the Library and Icon Menu Paths section of the [Project properties: project settings tab](#) on page 204. Use the Icon Menu Wizard to modify the menu. The default icon menu can also be redefined in *wd.env*. Add entry "WD\_MENU" for schematic icon menu and "WD\_PMENU" for panel layout icon menu.

### Insert Component

 **Ribbon:** Schematic tab ► Insert Components panel ► Insert Components

drop-down ► Icon Menu.



 **Toolbar:** Main Electrical

 **Menu:** Components ► Insert Component

 **Command entry:** AECOMPONENT



### Multiple Insert (Icon Menu)

 **Ribbon:** Schematic tab ► Insert Components panel ► Multiple Insert

drop-down ► Multiple Insert (Icon Menu).



 **Toolbar:** Main Electrical

 **Menu:** Components ► Multiple Insert ► Multiple Insert (Icon Menu)

 **Command entry:** AEMULTI



---

**NOTE** This dialog box is also accessed when inserting Pneumatic, Hydraulic, or P&ID components; in-line wire labels; stand-alone cross-reference symbols; cable markers; and saved circuits.

---

Select an icon picture or the component type from the Menu tree structure. The main menu in the tree structure is displayed as the menu heading just above the menu tree structure.

<b>Tabs</b>	<ul style="list-style-type: none"><li>■ Menu: Changes the visibility of the Menu tree view.</li><li>■ Up one level: Displays the menu that is one level before the current menu in the Menu tree view. This option is unavailable if the main menu is selected in the Menu tree view.</li><li>■ Views: Changes the view display for the Symbol Preview window and Recently Used window. The current view option is indicated with a check mark. Options include: Icon with text, Icon only or List view.</li></ul>
<b>Menu</b>	The tree structure is created by reading the icon menu file (.dat). The tree structure is based on the arrangement order of submenus defined in the .dat file.
<b>Symbol Preview window</b>	Displays the symbol and submenu icons corresponding to the menu or the submenu selected in the Menu tree structure. Clicking on the icon performs one of the following functions based on the icon properties as defined by the .dat file: <ul style="list-style-type: none"><li>■ Inserts the symbol or circuit onto the drawing</li><li>■ Executes a command</li><li>■ Displays a submenu</li></ul> <hr/> <p><b>NOTE</b> When you move the cursor over an icon, the icon name and block/circuit/command name display as tooltip information.</p> <hr/>
<b>Recently Used</b>	Displays the last components inserted during the current editing session; the most recently used icon displays in the top. This list follows the view options setting in the symbol preview window (icon only, icon with text or list view). The total number of icons displayed depends on the value specified in the Display edit box.
<b>Display</b>	Specifies the number of icons to display in the Recently Used list box. Enter integer numbers only; the default value is 10.

<b>Vertical/Horizontal</b>	Inserts the icon using a vertical or horizontal orientation. This value is opposite the default ladder rung orientation for the drawing.
<b>No edit dialog</b>	Turns off the Insert/Edit Component dialog box when inserting symbols onto the drawing. To add component detail later, click the Edit Component tool, and select the component to edit.
<b>No tag</b>	Inserts the component, untagged (that is, without assigning a unique Component Tag). The untagged value that displays is the TAG1/TAG2 default value for the component. To add component detail later, click the Edit Component tool, and select the component to edit.
<b>Always display previously used menu</b>	Indicates to display the previously used menu each time you open the Insert Component dialog box. For example, if you insert a push button from the Push Buttons menu, the next time you open the Insert Component dialog box the Push Button menu displays by default.
<b>Scale schematic</b>	Specifies the component block insertion scale. This defaults to the value set in the Drawing Properties ► Drawing Format dialog box. Once set, this value is remembered until reset or until the drawing editing session ends.
<b>Scale panel</b>	Specifies the footprint insertion scale. This defaults to the value set in the Drawing Properties ► Drawing Format dialog box. Once set, this value is remembered until reset or until the drawing editing session ends.
<b>Type it</b>	Manually type in the component block to insert.
<b>Browse</b>	Browses to and selects the component to insert.

### **Right-click menus**

#### **Options for the Menu tree structure view**

Right-click on the main menu or submenu in the Menu tree structure view to display the following options:

- **Expand/Collapse:** Toggles the visibility of the menus.

- Properties: Opens a Properties dialog box to view the existing menu or submenu properties like the menu name, image, or submenu title. Use the Icon Menu Wizard to change any menu properties.

#### Options for the Symbol Preview window

Right-click an icon or in empty space in the Symbol Preview window to display the following options:

- View: Changes the view display for the Symbol Preview window and Recently Used window. The current view option is indicated with a check mark. Options include: Icon with text, Icon only or List view.
- Properties: (available for icons only) Opens a Properties dialog box to view the existing symbol icon properties like the icon name, image, block names and so on. Use the Icon Menu Wizard to change any icon properties.

#### Pneumatic, Hydraulic, and P&ID icon menus

The Menu tree structure displays the symbols for the selected component type (pneumatic, hydraulic, or P&ID). The Insert Pneumatic Component, Insert Hydraulic Component, and Insert P&ID Component tools are accessed from the Schematic tab ► Insert Components panel on the ribbon or the Extra Library toolbar.



Insert Pneumatic Component



Insert Hydraulic Component



Insert P&ID Component



# Troubleshooting Tools

## Overview of real-time error checking

Although AutoCAD Electrical checks for duplicated schematic component reference designations and wire numbers during the insert or edit process, you have the option of displaying the warning in real time. Real-time error checking is enabled by default in the Project Properties ► [Project Settings](#) on page 204 tab.

If you enter an existing component tag/wire number during the insert/edit process, a warning dialog box displays. This alerts you of the duplication and suggests alternative tag names based on the user-defined format. You can select whether to use the duplicated tag or use a new tag that is suggested (or you can type in a new tag).

---

**NOTE** The combined value of the component tag and installation code is used for error checking in IEC mode.

---

An error log file is created for every project if you chose to display the real-time warnings. The real-time warning is saved in the log file named "<project\_name>\_error.log" and is saved in the User subdirectory. If a log file exists, the new content is added to the same file. A blank line separates one error record from another.

### About the .wdn file

The .wdn file is a text file used specifically for auditing terminals. Terminal numbers listed in this file are not checked for duplication. Use wildcards to exclude a range of terminals for duplication checking such as all terminals with a tag name starting with "T" and with terminal number "1." AutoCAD Electrical searches for the <project\_name>.wdn file in the same folder as the project definition file (\*.wdp). If <project\_name>.wdn is not found, AutoCAD Electrical looks for the default.wdn file in the project folder.

- **Windows XP:** C:\Documents and Settings\{username}\My Documents\Acade {version}\AeData\Proj\
- **Windows Vista, Windows 7:** C:\Users\{username}\Documents\Acade {version}\AeData\Proj\

The default .wdn file contains the terminal number filters GND, PE, and E. They are ignored when checking for duplication and are not listed in the Electrical Audit report.

## Use the troubleshooting tools

There are many tools to use for troubleshooting your AutoCAD Electrical drawing.

### Use the audit tool

Use this tool to identify and clean up some types of problems that affect an AutoCAD Electrical drawing. The Electrical Audit tool displays a report of detected problems for the active project. You can save this file for reference or surf the file to view and correct the errors.



- 1 Click Reports tab ► Schematic panel ► Electrical Audit.  
When you run the command, the progress bar describes the progress of the audit process. Once the audit is complete, a text box displays the total number of errors found.
- 2 Click Details to view the detected problems.
- 3 (Optional) Click Active Drawing to view the detected problems for the active drawing only.
- 4 Click any of the tabs highlighted with an error icon.  
They are the areas where problems were found in your project. If no errors are found, the Details button is not enabled.
- 5 Click an audit record in the dialog box and click Go To (or double-click the audit record).  
Once you browse to an error location an 'x' appears in the audit dialog box.
- 6 Fix the error using any of the AutoCAD Electrical editing tools.  
After correcting the error, you can select another audit record in the dialog box for correction.
- 7 Click Close after correcting errors, Save As/Save All if you want to save the report, or Print if you want to print the report.

---

**NOTE** Run the [Drawing audit](#) on page 1692 tool to perform wire-related clean-up functions automatically.

---

### Clean the drawings

- 1 Click Project tab ► Troubleshooting panel ► Clean DWG Utility.



- 2 On the Clean Drawing Utility dialog box, select the drawings to clean: drawings in the active project, a single drawing, or all drawings in a selected folder.
- 3 (Optional) Click Purge All to run the AutoCAD Purge command and purges all unused items (such as block definitions, dimension styles, layers, linetypes, and text styles).
- 4 Click OK.
- 5 If you selected to clean all drawings in the active project, select the drawings to process and click OK.  
New, clean copies of the selected drawings are created and inserted into the drawing.

### Use the debug tool

If you receive a message that AutoCAD Electrical is having trouble updating your scratch database file of the project, turn on the Debug Trace. It can help track down the problem. Select one of the following commands:

- Click Project tab ► Troubleshooting panel ► MDB Command Trace



drop-down ► MDB Command Trace On.  
To turn the tracing off,

- Click Project tab ► Troubleshooting panel ► MDB Command Trace



drop-down ► MDB Command Trace Off.

- Click Project tab ► Troubleshooting panel ► Command Trace drop-down



► Command Trace On.  
To turn the tracing off,

Click Project tab ► Troubleshooting panel ► Command Trace drop-down

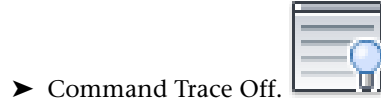



## Check, repair, or trace wire and gap pointers

The Check/Repair Gap Pointers utility verifies that the invisible Xdata pointers on both sides of a wire gap/loop are valid. If not, appropriate pointers are established. The Check/Trace a Wire utility single steps through and highlights each connected wire of the selected wire network.

### Check/repair wire gaps

Use this utility to create wire number jumps (on the current drawing) without resorting to individual signal source/destination arrow symbols.

- 1 Click Schematic tab ► Edit Wires/Wire Numbers panel ►  ►    
Modify Wire Gap drop-down ► Check/Repair Gap Pointers.

2 Click the Check/Repair Gap Pointers tool.

3 Select each wire segment as directed.

Gap data is added as needed. The result of the check/repair is shown in the command prompt area.

### Check/trace a wire

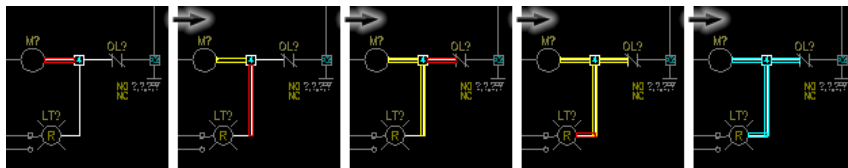

Troubleshoot problems with unconnected or shorted wires and invalid wire crossing gap pointers.

- 1 Click Schematic tab ► Edit Wires/Wire Numbers panel ► Modify Wires



drop-down ► Check/Trace Wire.

- 2 Select a wire on the network. You can select "A" to show All Segments. If you prefer to step through wire by wire, press the spacebar.
- 3 Determine whether to pan or zoom the selected wire.  
The connected wire segments endpoints are shown in the command prompt area.

### Check multiple wires



- 1 Click Reports tab ► Schematic panel ► DWG Audit.
- 2 Select whether to process the active drawing or the entire project, and click OK.
- 3 Indicate which areas to check for errors. You can look for problems related to missing wires segments which were linked through wire crossing gap pointers. You can also clean up wires pointing to nonexistent wire numbers and erase wire numbers that are not linked to a wire network. Show all valid wire segments by having each outlined in temporary graphics. Temporary graphics are shown as:
  - Bright red - regular wires
  - Magenta - wires on layers defined as No Wire Numbering.
- 4 Click OK.  
The Drawing Audit utility displays a report of wire-related clean-up functions that were performed.

### Electrical audit

Detects problems related to wires and components, and describes the problems in a dialog box on a series of tabs.



 **Ribbon:** Reports tab ► Schematic panel ► Electrical Audit.

-  **Toolbar:** Schematic Reports
-  **Menu:** Projects > Reports > Electrical Audit
-  **Command entry:** AEAUDIT

When you run Electrical Audit, a progress bar shows the progress of the audit process. Once the audit is complete, a text box displays the total number of errors found. The Details option lists the detected problems. You can go to the location of an error within the project and correct the error.

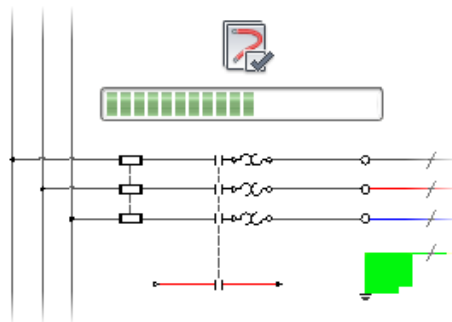

- Project** Displays the audit information for all the drawings in the active project.
- Active Drawing** Displays the audit information for the active drawing only. If a different drawing becomes active, the display updates for that drawing. If the active drawing is not part of the project, the Active Drawing control is disabled and the Project control is selected.
- Wire - No Connection** Displays the unconnected wires for the active project. The report lists the unconnected wire number, location point, error message, and the drawing where the error occurs. If there is not a record of a wire number, the wire number column is blank.
- Wire Exception** Displays missing or duplicated wire numbers for the active project. The report lists the duplicated wire number, error message, and the drawing where the error occurs. If a wire number is missing, the wire number column is blank.

<b>Cable Exception</b>	Displays the duplicated cable and wire id for the active project. The report lists the duplicated cable tags or cable tags with duplicated wire id, error message, reference of the cable tag, and the drawing where the error occurs.
<b>Component - No Catalog Number</b>	Displays components with no bill of material part assignments. The report lists the component reference designation tag, component category, reference of the component tag, error message, and the drawing where the error occurs.
<b>Component Duplication</b>	Displays the duplicated components. The report lists the component reference designation tag, component category, reference of the component tag error message, and the drawing where the error occurs.
<b>Component - No Connection</b>	Displays component connections with no connected wires. The report lists the component reference designation tag, component category, reference of the component tag, error message, and the drawing where the error occurs.
<b>Mixed Component Network</b>	Displays components in the wire network that carry a mixture of different <b>WDTYPE</b> on page 325 attribute values. For example, a one-line symbol (WDTYPE value of "1-") connected to a schematic symbol (WDTYPE value missing or blank).
<b>Terminal Duplication</b>	<p>Displays duplicated schematic terminal numbers. The report lists the terminal tag id and duplicated terminal number, reference of the terminal number, error message, and the drawing where the error occurs.</p> <hr/> <p><b>NOTE</b> Terminal numbers listed in WDN files (located in the same folder as the project definition file (*.wdp)) are not checked for duplications. You can use wildcards to exclude a range of terminals for duplication checking using this text file.</p> <hr/>
<b>Pin Exception</b>	Displays duplicated component pin assignments. The report lists the schematic component reference designation tag and component wire connection pin, reference of the component tag, error message, and the drawing where the error occurs.

<b>Contacts</b>	Displays any children without a parent schematic component. The report lists the component reference designation tag for the child without a parent, reference of the child component tag, error message, and the drawing where the error occurs.
<b>Recovery Tip</b>	Displays the recovery tip so that you can fix the error.
<b>Go To</b>	Goes to the error location within the project and correct the error. It is enabled when you select a single audit record in the dialog box. Once you browse to an error location an "x" appears in the left-hand column of the Electrical Audit dialog box. <hr/> <b>NOTE</b> You can also double-click an audit record to go to the error location. <hr/>
<b>Save As/Save All</b>	Saves the audit report. Save As saves only the active report while Save All saves the complete audit report.
<b>Print</b>	Prints the audit report.

---

**NOTE** A blank Category value indicates a schematic component.

---

## Drawing audit

Detects problems related to wire numbers in the active project and displays a report of them.

 **Ribbon:** Reports tab ► Schematic panel ► DWG Audit. 

 **Toolbar:** Schematic Reports 

 **Menu:** Projects ► Reports ► Drawing Audit

 **Command entry:** AEAUDITDWG



Drawing Audit identifies and cleans up some of the problems that can affect an AutoCAD Electrical drawing. Save the error report file for reference or surf the file to view and correct errors.

<b>Audit drawing or project</b>	Specifies to run the audit on the active drawing or selected drawings in the active project.
<b>Previous</b>	Redisplays the last audit report that was run. You can then surf to the performed function, save the report, or print the report for reference.
<b>Surf</b>	Goes to the error location within the drawing where the error occurred and was fixed.

After you click OK, you can select the type of drawing audit to run. If you selected to audit the project, select the drawings in the active project to audit, and click OK.

<b>Wire gap pointers</b>	Looks for problems related to missing wires which were connected through gap pointers. Also see <a href="#">Check / Repair Gap Pointers</a> on page 1688.
<b>Bogus wire number and color/gauge label pointers</b>	Looks for and cleans up wires pointing to nonexistent wire numbers (it is the opposite of wire number floaters). Also looks for bad color/gauge label pointers.
<b>Zero length wires</b>	Looks for and erases zero length line entities on the wire layer.
<b>Wire number floaters</b>	Looks for and erases wire numbers that are not linked to a wire network (for example, the wire was manually erased but wire number remains).
<b>Show wires (mark in red)</b>	Draws an outline around each wire entity. <ul style="list-style-type: none"><li>■ Bright red outline - regular wires</li><li>■ Magenta outline - wires on layers defined as No Wire Numbering.</li></ul> <p>(Available when running on the active drawing only.)</p>

## Modify invisible data

### Modify invisible data

For some functions AutoCAD Electrical adds invisible information to a block insert or even to a specific attribute. This invisible data is called Xdata. To add or modify this invisible data, AutoCAD Electrical provides an Xdata editor.

### Edit existing invisible data

- 1 Click Project tab ► Other Tools panel ►  ► Xdata Editor.



- 2 Select an attribute in the drawing.
- 3 If Xdata exists for the attribute, select the Xdata to edit from the list in the dialog box.  
The existing name and value are shown in the edit boxes allowing you to edit them.
- 4 Edit the name and value as needed. Once you click out of the edit box, the name, or value are updated in the list.
- 5 Click Save Changes to update the selected block or attribute with the Xdata changes.

### Add invisible data to an attribute

- 1 Click Project tab ► Other Tools panel ►  ► Xdata Editor.





- 2 Select an attribute in the drawing.  
If the selected block or attribute does not carry any Xdata, the list box indicates it.
- 3 Click Add New.

- 4 Enter the name for the Xdata and its value. Click OK.
- 5 Click Save Changes to update the selected block or attribute with the Xdata changes.

## Xdata editor

For some functions AutoCAD Electrical adds invisible information to a block insert or even to a specific attribute. This invisible data is called Xdata. To add or modify this invisible data, AutoCAD Electrical provides an Xdata editor.

 **Ribbon:** Project tab > Other Tools panel >  > Xdata Editor.



 **Menu:** Projects > Extras > Xdata Editor

 **Command entry:** AEXDATA

The dialog box displays showing any existing Xdata information. If the selected block or attribute does not carry any Xdata, the list box indicates it. If the selected block or attribute carries any Xdata already, the names and values are displayed in the list box at the top of the dialog box.

<b>Name</b>	Specifies the Xdata name. To edit the name, click it in the list. The existing name is shown in the edit boxes allowing you to edit it. Once you click out of the edit box, the name is updated in the list.
<b>Value</b>	Specifies the Xdata value. To edit the value, click it in the list. The existing value is shown in the edit boxes allowing you to edit it. Once you click out of the edit box, the value is updated in the list.
<b>Add New</b>	Adds new Xdata information. Enter in the application name for the Xdata and its value.
<b>Delete Xdata</b>	Removes the selected Xdata from the list.



## Introduction

AutoCAD Electrical currently supports the following industry standards: JIC (US), IEC (Europe), JIS (Japan), GB (China) and AS (Australia). Although AutoCAD Electrical supports many standards, these exercises follow the JIC standard and sample drawing set.

The exercises are grouped into main topics. Each main topic contains one or more individual exercises. You can perform the main topics in any order but perform the exercises within a main topic in order.

It is assumed that you have a working knowledge of the AutoCAD interface and tools. If you do not, review the AutoCAD online documentation.

It is recommended that you have a working knowledge of Microsoft® Windows® 2000 or Windows® XP, and a working knowledge of electrical design and schematic ladder wiring diagrams.

---

**NOTE** Turn off the AutoCAD Dynamic Input feature (found on the status bar) before starting the exercises.

---

The tutorial uses a naming convention when referring to ribbon commands. For example, in the selection path *Schematic tab* ► *Insert Components panel* ► **Circuit Builder**, *Schematic* is the name of the tab, *Insert Components* is the name of the panel on the tab, and **Circuit Builder** is the name of the command.

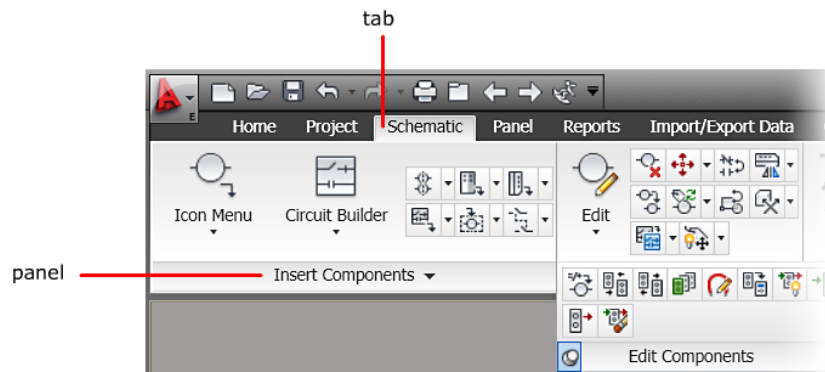

### Backup exercise files

Backup exercise files are found at *Documents and Settings\{username}\My Documents\Acade {version}\Aedata\Tutorial\Aegs*. If you make a mistake while working through the exercises, browse to and copy the demo files to your project folder.

Completed exercise files for each tutorial are found at *Documents and Settings\{username}\My Documents\Acade {version}\Aedata\Tutorial\Aegs\Completed\{tutorial\_name}\*. If you do not complete the exercises in order, browse to and copy the files for the prior tutorial to your project folder. For example, if you skipped the *Projects* tutorial and are starting with the *Wiring* tutorial, copy the *Documents and Settings\{username}\My Documents\Acade {version}\Aedata\Tutorial\Aegs\Projects\* exercise files to the project folder.

---

**NOTE** Backup exercise files are found at *Users\{username}\Documents\Acade {version}\Aedata\Tutorial\Aegs* on a Windows Vista or Windows 7 installation.

---

### Manufacturers used

The exercises use two manufacturers: Allen Bradley and Siemens. Install both manufacturers to have the same results that are shown here. Follow these steps to install content from these manufacturers.

- 1 Open the Add or Remove Programs tool in your Control Panel.
- 2 Select AutoCAD Electrical
- 3 Click Change/Remove.
- 4 Click Add/Remove Features.

- 5 Click Next on the first screen.
- 6 Select AB and Siemens on the Manufacturer Contents Selection screen and click Next.
- 7 Click Next on the Symbol Libraries screen.
- 8 Click Next to continue.

## Projects

### Projects - Introduction

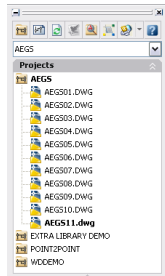

Create a project and add drawings with Project Manager.

Time required 10 minutes

Prerequisites: Copy all files located in

**Windows XP** *Documents and Settings\{username}\My Documents\Acade {version}\Aedata\Tutorial\Aegs\Projects*  
to  
*Documents and Settings\{username}\My Documents\Acade {version}\Aedata\Proj\Aegs*

**Windows Vista, Windows 7** *Users\{username}\Documents\Acade {version}\Aedata\Tutorial\Aegs\Projects*  
to  
*Users\{username}\Documents\Acade {version}\Aedata\Proj\Aegs*

You learn to:

- Understand projects

- Create a project
- Set project properties
- Create a drawing
- Add drawings to a project
- View drawings in a project

## Working with projects

AutoCAD Electrical is a project-based system. An ASCII text with a *.wdp* extension defines each project. This project file contains a list of project information, default project settings, drawing properties, and drawing file names. You can have an unlimited number of projects; however, only one project can be active at a time.

Use the Project Manager to add new drawings, reorder drawing files, and change project settings. You cannot have two projects open in the Project Manager with the same project name. By default, the Project Manager is open and docked on the left-hand side of your screen. You can dock the Project Manager into a specific location on the screen or hide it until you want to use the project tools. Right-click the properties icon to display options to move, size, close, dock, hide, or set the transparency for the Project Manager.

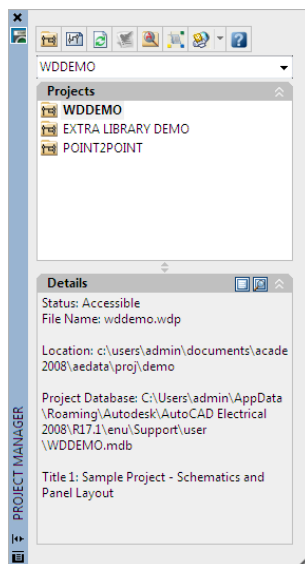



## Create an AutoCAD Electrical project

- 1 Click Project tab ► Project Tools panel ► Manager.



- 2 In the Project Manager, click the New Project tool.



---

**NOTE** You can also use the Project Manager to open an existing project. In the Project Manager, click the project selection arrow and select Open Project.

---

- 3 In the Create New Project dialog box, specify:

Name: AEGS

A name must be entered to define any of the project properties. The *.wdp* extension is not required in the edit box.

- 4 Make sure *wddemo.wdp* is specified in the Copy Settings from Project File edit box.

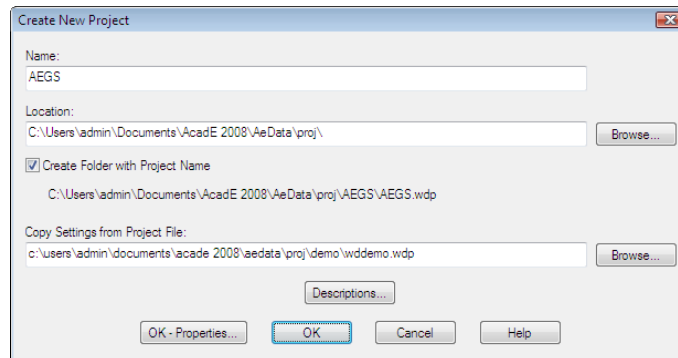

- 5 Click OK-Properties.

Your new project is added to the current projects list and automatically becomes the active project.

The Project Properties dialog box displays, where you can modify your project default settings. All information defined on these tabs are saved to the project definition file as project defaults and settings.

## Set project properties

- 1 In the Project Properties dialog box, click the Components tab.
- 2 In the Component Tag Format section, verify that Line Reference is selected.

This selection creates unique reference-based tags when multiple components of the same family are located at the same reference location. When reference-based tagging is used, a suffix variable is required to keep components of the same family type unique. For example, three push buttons on line reference 101 could be labeled PB101, PB101A, and PB101B. Click Suffix Setup to change the suffix variable.

- 3 Click the Wire Numbers tab.
- 4 In the Wire Number Format section, verify that Line Reference is selected.

This selection creates unique reference-based wire number tags for multiple wire networks beginning at the same reference location. When reference-based numbering is used, a suffix variable is required to keep wires on the same reference line or in the same reference zone unique. Click Suffix Setup to change the suffix variable.

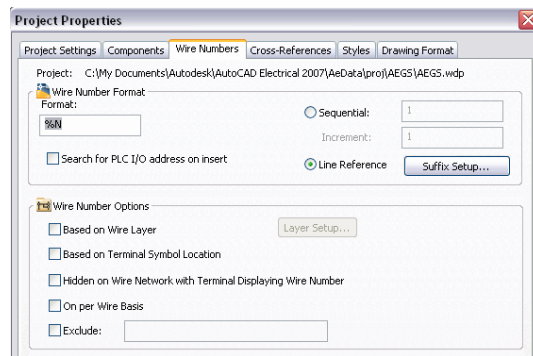

- 5 Review the various options on the different tabs of the Project Properties dialog box.

---

**NOTE** In the Project Properties dialog box, icons indicate whether the settings apply to project settings or drawing defaults. Settings that apply to project settings have the project icon next to them and are saved inside the project definition file (\*.wdp). Settings that are saved in the project file as drawing defaults have the drawing icon next to them. Drawing related data to add to the project when running the Add Drawing command is saved as Drawing Custom Properties.

---

- 6 Click OK.

## Working with drawings

A single project file can have drawings located in many different directories. There is no limit to the number of drawings in a project. You can add drawings to your project at any time. When you create a drawing, using the New Drawing tool, it is automatically added to the active project.

Many of the drawing settings used by AutoCAD Electrical are stored in a smart block on the drawing named *WD\_M.dwg*. Each AutoCAD Electrical drawing should contain only one copy of the *WD\_M* block. If multiple *WD\_M* blocks are present, the settings cannot be stored and read consistently.

### Create a drawing

- 1 In the Project Manager, click the New Drawing tool. 

- 2 In the Create New Drawing dialog box, specify:

Name: AEGS11

Description 1: Bill of Materials Report

- 3 Click Browse next to the Template edit box.

A set of templates (\*.dwt files) installed with AutoCAD Electrical contain settings for various kinds of drawings, such as *acad.dwt* and *ACAD\_ELECTRICAL.dwt*.

You can create your own templates, or use any drawing as a template. You can save a drawing at any stage of completion as a template file. When you use a drawing as a template, the settings in that drawing are used in the new drawing. The changes you make to a drawing that is based on a template do not affect the template file.

AutoCAD Electrical fully supports the use of AutoCAD template files. To make an AutoCAD drawing compatible with AutoCAD Electrical, select an AutoCAD Electrical command to modify the drawing.

- 4 In the Select template dialog box, select *ACAD\_ELECTRICAL.dwt*, and click Open.

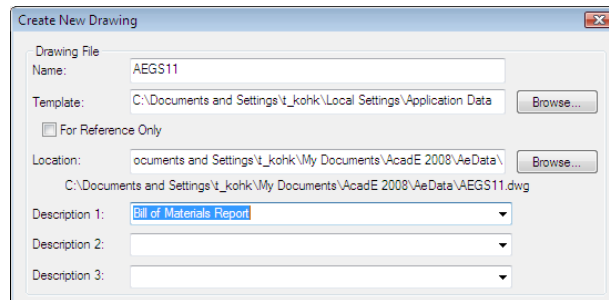

- 5 In the Create New Drawing dialog box, click OK.

---

**NOTE** You could click OK-Properties to display the Drawing Properties dialog box. This dialog box has options like the options found in the Project Properties dialog box. It defines drawing-specific settings that are maintained inside the WD\_M block of the drawing.

---

- 6 In the Project Manager, double-click the project name (AEGS) to display the drawing files. AEGS11 is the only file in the list.

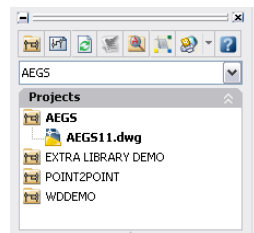

## Add drawings to the project

- 1 In the Project Manager, right-click AEGS, and select Add Drawings.
- 2 In the Select Files to Add dialog box, select drawings *AEGS01.dwg* to *AEGS10.dwg* and click Add.
- 3 When asked whether to apply the project default values to the drawing settings, click Yes.

The Project Manager lists the files under the AEGS folder. New drawings that you add from this point on are added at the end of the drawing order. You now have access to the files required for the exercises in this book.

---

**NOTE** Two projects can reference the same drawing file. However, if both projects try to modify the same drawing with a project-wide tagging or cross-referencing function, it can lead to conflicts.

---

The drawing order in the Project Manager determines how AutoCAD Electrical processes the drawings during project-wide operations such as resequencing and wire numbering.

- 4 In the Project Manager, right-click the project name, and select Reorder Drawings.
- 5 In the Reorder Drawings dialog box, select *AEGS10.dwg* and *AEGS11.dwg* and click Move Down until the drawings are at the bottom of the list.
- 6 Click OK.

*AEGS11.dwg* is now at the bottom of the project drawing file list in the Project Manager.

---

**NOTE** The active drawing displays in bold text in the project drawing list. You can easily see which file you are working in.

---

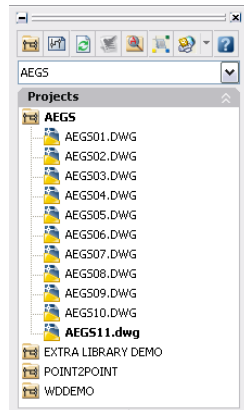

You can add descriptions for each drawing to the project file. You can reuse drawing descriptions in title block attributes and associate them with AutoCAD Electrical reports.

### Add the description of a drawing you add

- 1 In the Project Manager, right-click *AEGS10.dwg*, and select Properties ► Drawing Properties.

- 2 In the Drawing Properties ► Drawing Settings dialog box, Drawing File section, specify:

Description 1: Connector Drawing

- 3 Click OK.
- 4 In the Project Manager, select *AEGS10.dwg*.
- 5 In the Project Manager, Details section, review the drawing descriptions.  
The drawing details update when you highlight a drawing file and remain visible until a new drawing file is selected. Displayed information includes the status, file name, file location, file size, last saved date, and the name of the last user who modified the file.

Use the Project Manager to preview drawings easily. Moving among drawings using the up and down keys does not open the drawing. It changes the preview or details display in the Project Manager.

## View drawings in a project

- 1 In the Project Manager, select *AEGS04.dwg*.
- 2 In the Project Manager, Details section, click Preview.

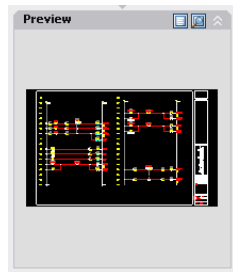

- 3 Continue to click the drawing name you want to preview or use the up and down arrow keys to scroll through the drawing files.
- 4 When you finish viewing the drawings, click Details to return to the drawing details view.

If a project drawing is currently open and you want to move to the previous or next drawing in the list of the project, use the Previous Project Drawing and Next Project Drawing tools. When you move among drawings, any unsaved changes to the current drawing are saved, the drawing is closed, and the requested drawing is opened.

## View project drawings when a drawing is open

- 1 In the Project Manager, double-click *AEGS04.dwg*.
- 2 To view the drawings, Click Project tab ► Other Tools panel ► Previous



or Click Project tab ► Other Tools panel ► Next DWG.

A new window opens and the original window closes when you click the navigation tools unless you hold the Shift key while clicking the tools.

## Title Block

### Title Block - Introduction

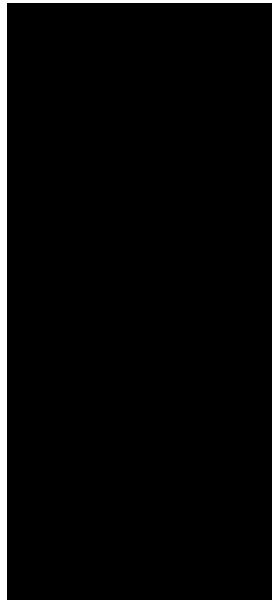

Create a title block and link it to the Title Block Update. Select either the WD\_TB attribute method or the WDT file method, and perform only the exercises for that method. The same files are used for both methods.

Time required	40 minutes
Prerequisites:	Copy all files located in
<b>Windows XP</b>	<i>Documents and Settings\{username}\My Documents\Acade {version}\Aedata\Tutorial\Aegs\Title Block</i> to <i>Documents and Settings\{username}\My Documents\Acade {version}\Aedata\Proj\Aegs</i>
<b>Windows Vista, Windows 7</b>	<i>Users\{username}\Documents\Acade {version}\Aedata\Tutorial\Aegs\Title Block</i> to <i>Users\{username}\Documents\Acade {version}\Aedata\Proj\Aegs</i>

You learn to:

- Create a title block border drawing.
- Link to Title Block Update using the WD\_TB attribute method.
- Link to Title Block Update using the WDT file method.
- Create a template drawing file using the title block.
- Customize project description dialog box labels.

## Title Block Utility

AutoCAD Electrical can link project description lines and some of the drawing properties to attributes on the drawing title block. The title block utility:

- automates project-wide title block updates
- supports multiple title blocks per drawing
- maps AutoCAD Electrical project description lines to specific attributes
- maps AutoCAD Electrical per-drawing values to specific attributes
- maps AutoLISP values, system variables, or environment variables to specific attributes.



AutoCAD Electrical uses two methods to map the AutoCAD Electrical values to attributes on the title block:

- **WD\_TB attribute method - mapping information embedded on the title block.** This option is self-contained in the drawing and requires no external file. It is limited to the number of characters that can be placed on a single attribute.
- **WDT file method - external attribute mapping file.** This option can update the attributes on existing title blocks, even if the title block does not contain the WD\_TB attribute.

During a title block update, AutoCAD Electrical follows this sequence to determine which method to use.

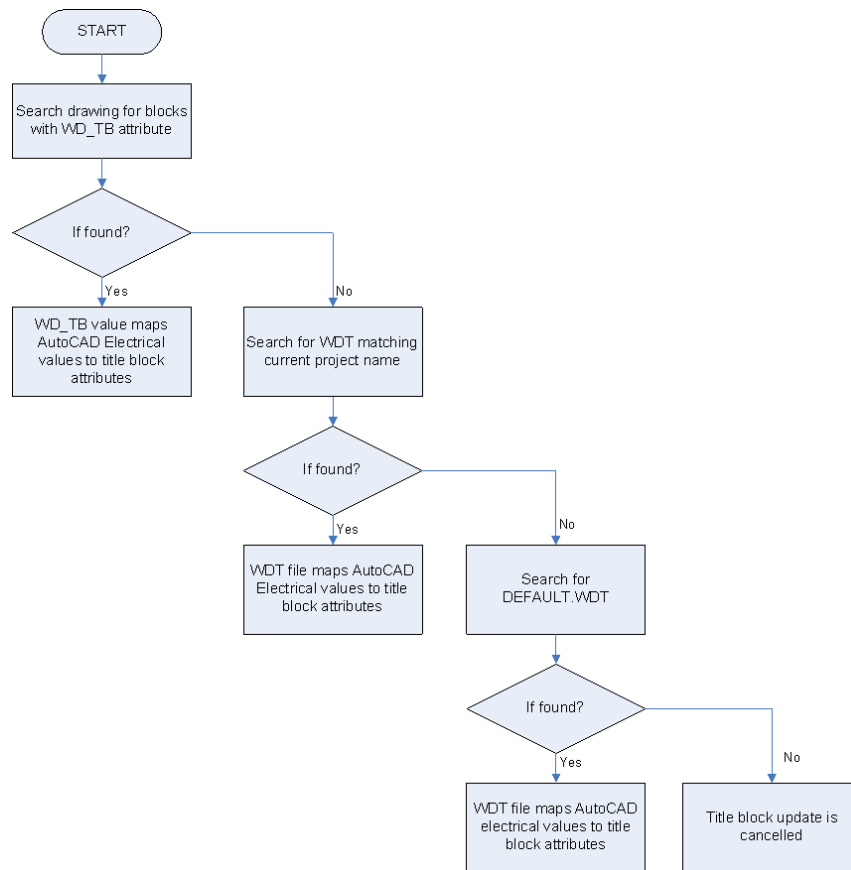

## Select method

Select either the [WD\\_TB attribute method](#) on page 1710 or the [WDT file method](#) on page 1724, and perform only the exercises for that method.

## WD\_TB attribute method

### Create a title block

---

**IMPORTANT** Select either the WD\_TB attribute method or the WDT file method and perform only the exercises for that method. The same files are used for either method.

---

The title block is a border drawing inserted as an AutoCAD block on another drawing. The title block border drawing can be inserted as a block on an AutoCAD drawing template file. If your drawing title block consists of an AutoCAD block with attributes, AutoCAD Electrical can link to it.

- Start a blank new drawing and draw your border using standard AutoCAD commands and objects.

Or

- 1 Open *ACADE\_TITLE\_BORDER.DWG* in:
  - **Windows XP:** *Documents and Settings\{username}\My Documents\Acade{version}\Aedata\Proj\Aegs*
  - **Windows Vista, Windows 7:** *Users\{username}\Documents\Acade{version}\Aedata\Proj\Aegs*

This drawing contains a sample border without any of the attribute definition objects.

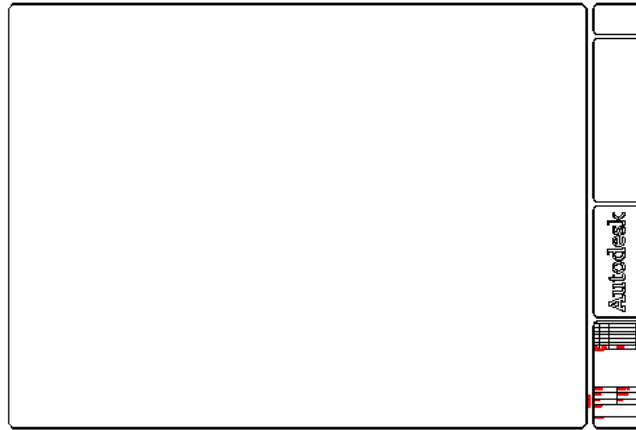

- 2 Zoom in for attribute definition placement.

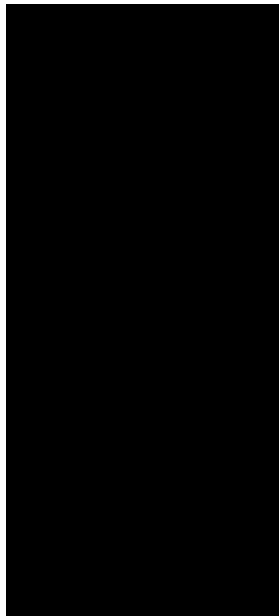

- 3 Enter *ATTDEF* at the command prompt to insert attribute definition objects.

---

**NOTE** When the border drawing is inserted as a block on another drawing, attribute definition objects become attributes.

---

- 4 Enter the Tag name SH#.

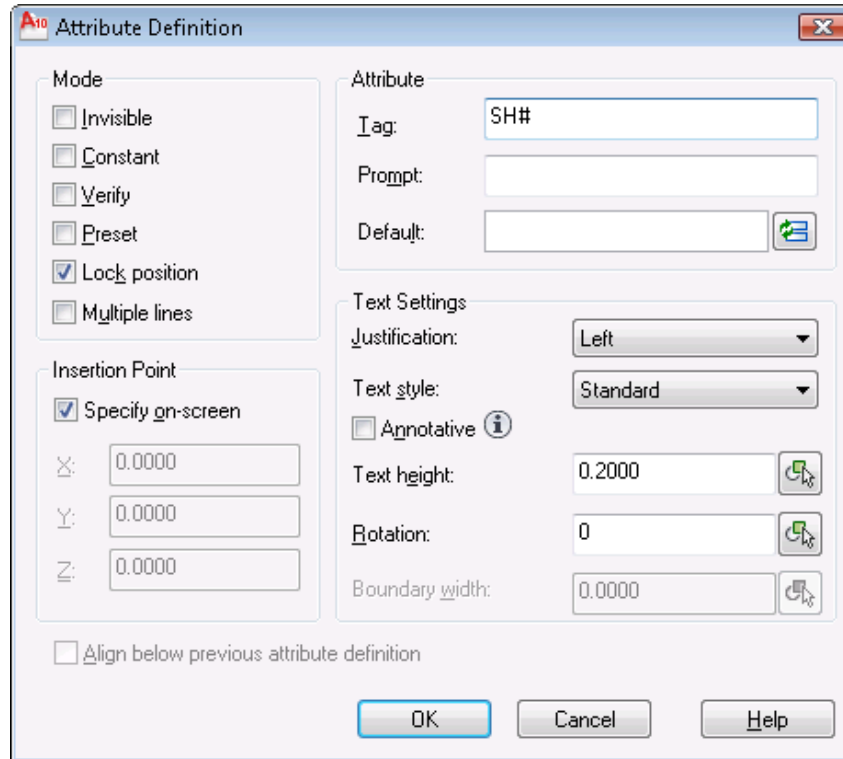

- 5 Set any other attribute definition properties and values, such as text style, height, and justification.
- 6 Select OK.
- 7 Specify the insertion point.

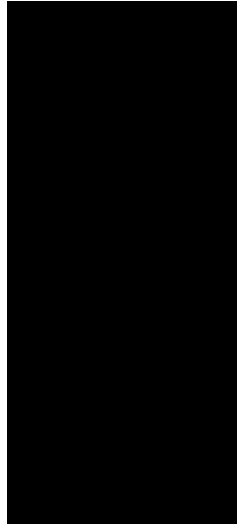

**8** Repeat for each attribute definition for the title block as shown.

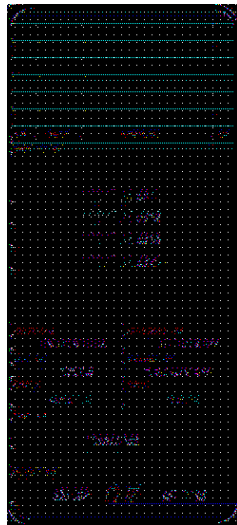

- 9** Enter *SAVEAS* at the command prompt.
- 10** Enter **File name:** acad\_title.
- 11** Select **Files of type:** AutoCAD Drawing (\*.dwg)
- 12** Click Save.

## Title Block Setup - WD\_TB attribute method

An invisible attribute on a title block of the drawing, named "WD\_TB," is encoded with the mapping information. This method eliminates the need for an external mapping text file.

- 1 Click Project tab ► Project Tools panel ► Manager. 
- 2 If AEGS is not the active project, activate the AEGS project.  
If AEGS is in the list of open projects:
  - Select AEGS and right-click.
  - Click Activate.If AEGS is not in the list of open projects:
  - Select the project list drop-down.
  - Click Open Project.
  - On the Select Project File dialog box, navigate to and select the *AEGS.WDP* file.
  - Click Open.
- 3 Open the title block base drawing created previously, *ACADE\_TITLE.DWG*, that contains the attribute definition objects.

- 4 Click Project tab ► Other Tools panel ► Title Block Setup. 
- 5 Select the title block link method: **Method 2: WD\_TB attrib.**
- 6 Click OK.  
Title Block Setup reads the attribute definitions. The Title Block Setup dialog box displays. Each drop-down list contains all the attribute definition objects found on the drawing.

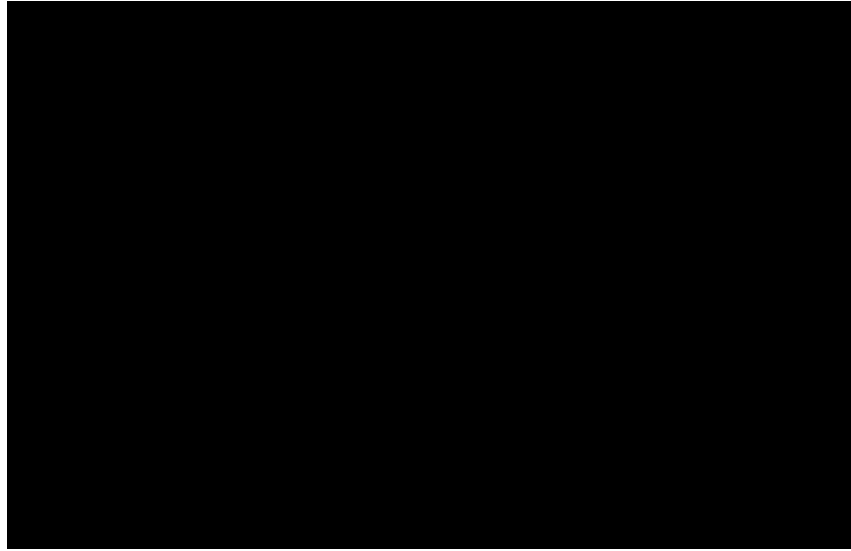

---

**NOTE** If no attribute definition objects are found on the drawing, an alert displays.

---

- 7 In the Title Block Setup dialog box, select the attribute from each list to map to its corresponding project description line.

TITLE#1 ► LINE1

TITLE#2 ► LINE2

JOB# ► LINE4

DRAWNBY ► LINE6

- 8 Click Drawing Values to assign drawing specific values.

- 9 Select the attribute from each list to map to its corresponding drawing value.

DWG# ► Drawing (%D value)

SH# ► Sheet (%S value)

SHTS ► Sheet Maximum

TITLE#3 ► Drawing Description 1

TITLE#4 ► Drawing Description 2

10 Click OK.

Title Block Setup updates the WD\_TB attribute definition with the selected mappings. If a WD\_TB attribute definition does not exist, Title Block Setup inserts it at 0,0.

11 Save the drawing.



**Show Me: Title Block Setup - WD\_TB attribute method**

Click the Play arrow to start the animation.

## Create a drawing template

A drawing template file is used to provide consistency in the drawings that you create by providing standard styles and settings.

When a drawing template file is used to start a new drawing it can:

- Predefine AutoCAD Electrical drawing properties such as component tagging, wire numbering format, and so on.
- Predefine layers and layer properties.
- Predefine wire layers.
- Provide your drawing border and title block.

By default, drawing template files are stored in the *template* folder, where they are easily accessible.

- 1 Enter *QNEW* at the command prompt to start a new drawing.
- 2 Select the *acad.dwt* template.
- 3 Click Open.
- 4 Enter *INSERT* at the command prompt.
- 5 Click Browse.
- 6 Navigate to and select the title block *ACADE\_TITLE.DWG* created for the border.
- 7 Click Open.



- 8 On the Insert dialog box, make sure the Explode option is not checked.
- 9 Click OK.
- 10 Specify the insertion point at 0,0,0.
- 11 If prompted for attribute values, leave them blank.

---

**NOTE** Attributes are invisible if no default values are assigned.

---

- 12 Click Schematic tab ► Other Tools panel ► Drawing Properties.



The alert displays.



- 13 Click OK to insert the WD\_M block.
- 14 Set the default drawing properties such as component tagging, wire numbering, cross-referencing, and so on.

---

**NOTE** No specific changes are needed for this tutorial.

---

- 15 Click OK.
- 16 Click Schematic tab ► Edit Wires/Wire Numbers panel ► Create/Edit



Wire Type.

- 17 Add wire layers as needed. Set the properties, color, linetype, and linewidth for each layer. For example:
  - In the Create/Edit Wire Type dialog box, click inside the Wire Color column for a blank row and enter *RED* for a new wire layer.
  - Click inside the Size column and enter *12* for the size. The Layer Name *RED\_12* is automatically created.
  - Click Color.
  - Select Red and click OK.
  - Click OK. The layer is created and defined as a wire layer.
- 18 Enter *SAVEAS* at the command prompt.
- 19 Set the file type as AutoCAD Drawing Template (\*.dwt).
- 20 Enter the file name, *AEGS\_ELECTRICAL*.
- 21 Click Save. The Template Options dialog box displays.
- 22 Select OK.
- 23 Close the drawing, *AEGS\_ELECTRICAL.DWT*.

## Use the template

- 1 If AEGS is not the active project, in the Project Manager, right-click AEGS and select Activate.
- 2 In the Project Manager, click the New Drawing tool. 
- 3 In the Create New Drawing dialog box, specify:
  - Name:** AEGS11
  - Description 1:** Title Block
  - Description 2:** Exercise
- 4 Click Browse next to the Template edit box.
- 5 In the Select template dialog box, select *AEGS\_ELECTRICAL.dwt*, and click Open.

- 6 In the Create New Drawing dialog box, click OK.
- 7 On the Apply Project Defaults to Drawing Settings dialog box, click No. Project Manager creates the drawing using the template containing the title block.

## Project description lines

The Title Block Update utility can update attributes on your title block with the project description lines.

- 1 Click Project tab ► Project Tools panel ► Manager. 
- 2 If AEGS is not the active project, in the Project Manager, right-click AEGS and select Activate.
- 3 In the Project Manager, right-click the project name, and select Descriptions.
- 4 In the Project Description dialog box, enter values:
  - Line 1: Tutorial Project
  - Line 2: AutoCAD Electrical
  - Line 4: Job #01000
  - Line 6: {your name}
- 5 Click OK.

## Drawing values

The Title Block Update utility can update attributes on your title block with certain drawing property values.

- 1 In the Project Manager, double-click to expand the AEGS project.
- 2 Right-click on drawing AEGS11 and select Properties ► Drawing Properties.

- 3 Enter values:  
**Sheet:** 11  
**Drawing:** 0211

---

**NOTE** Drawing Description 1 and 2 were defined when the drawing was created.

---

- 4 Click OK.
- 5 Save the drawing.

## Title Block Update

- 1 If AEGS is not the active project, in the Project Manager, right-click AEGS and select Activate.
- 2 In the Project Manager, double-click to expand the AEGS project.
- 3 Double-click drawing AEGS11 to open it.

- 4 Click Project tab ► Other Tools panel ► Title Block Update.  The Update Title Block dialog box displays.

- 5 Select the project and drawing values to update on the title block.
  - LINE1
  - LINE2
  - LINE4
  - LINE6
  - Drawing Description: 1 and 2
  - Drawing (%D value)
  - Sheet (%S value)
  - Sheet maximum
  - Resequence sheet %S values: 1

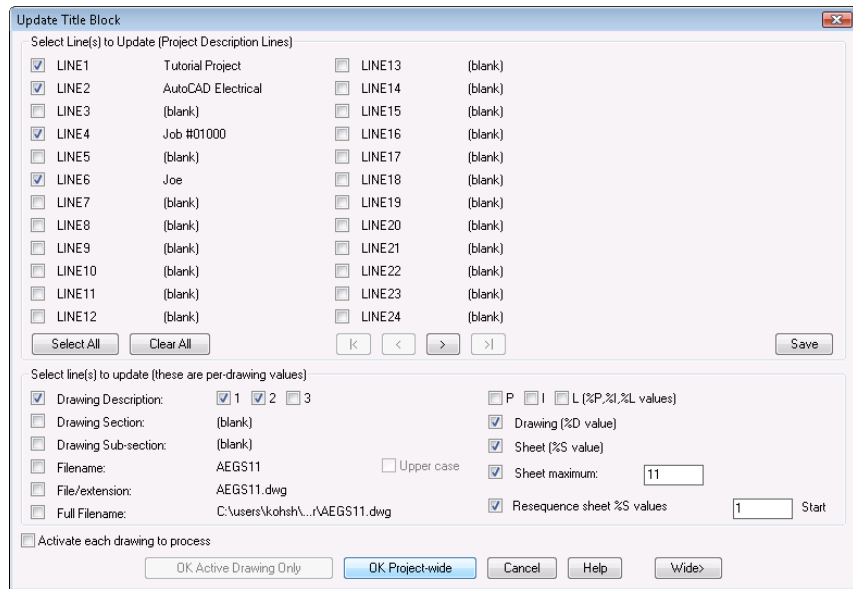

- 6 Click OK Project-Wide.
- 7 Select drawings AEGS01 through AEGS05, and AEGS11 to process. Click Process v.

---

**NOTE** Drawings AEGS01 through AEGS05 are supplied with the WD\_TB attribute on the title block for this exercise.

---

- 8 Click OK.

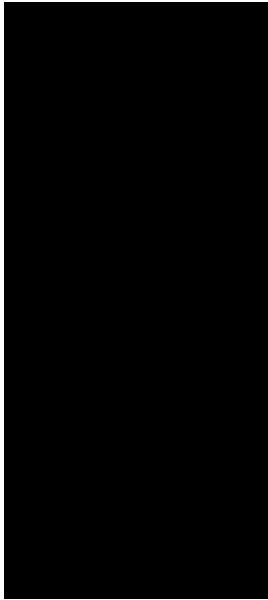

## Customize project description labels

The title block and project description dialog boxes in AutoCAD Electrical display generic labels like “LINE1”, “LINE2”, and so on. You can change these labels so they match up with the link to the title block. For example, you have linked the AutoCAD Electrical data “LINE4” value to the “JOB#” attribute on the title block. What you want to see when AutoCAD Electrical displays a title block-related dialog box is not “LINE4” but “Job Number.” A text file with a *WDL* extension defines the custom labels.

- 1 Use any generic text editor like Notepad or Wordpad and start a new text file.
- 2 Enter the lines as shown:  
LINE1 = Title 1  
LINE2 = Title 2  
LINE3 = Title 3  
LINE4 = Job Number  
LINE5 = Date  
LINE6 = Drawn By

LINE7 = Engineer  
LINE8 = Checked By  
LINE9 = Scale

- 3 Save the file as *AEGS\_WDTITLE.WDL* in the project folder.
  - **Windows XP:** *Documents and Settings\{username}\My Documents\Acade{version}\Aedata\Proj\Aegs*
  - **Windows Vista, Windows 7:** *Users\{username}\Documents\Acade{version}\Aedata\Proj\Aegs*
- 4 Switch over to AutoCAD Electrical.



- 5 Click Project tab ► Project Tools panel ► Manager.
- 6 If AEGS is not the active project, in the Project Manager, right-click AEGS and select Activate.
- 7 In the Project Manager, right-click the project name, and select Descriptions.

The labels match the values in the *WDL* file.

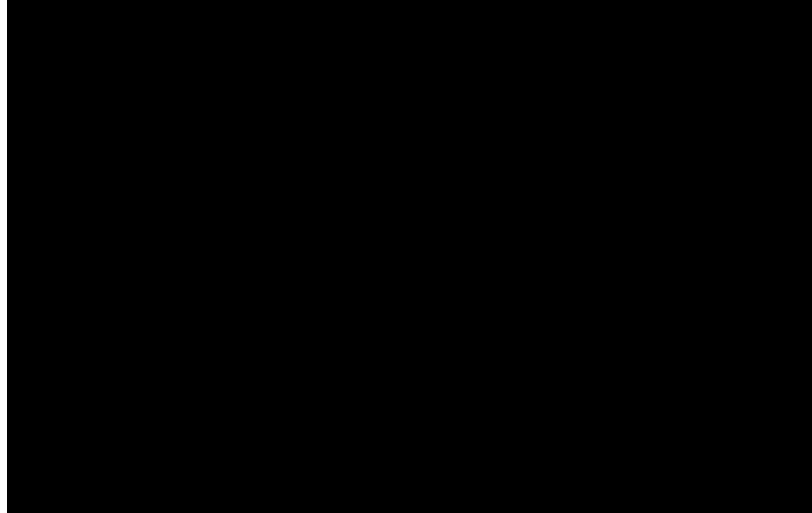

## WDT file method

### Create a title block

---

**IMPORTANT** Select either the WD\_TB attribute method or the WDT file method and perform only the exercises for that method. The same files are used for either method.

---

The title block is a border drawing inserted as an AutoCAD block on another drawing. The title block border drawing can be inserted as a block on an AutoCAD drawing template file. If your drawing title block consists of an AutoCAD block with attributes, AutoCAD Electrical can link to it.

- Start a blank new drawing and draw your border using standard AutoCAD commands and objects.

Or

- 1 Open *ACADE\_TITLE\_BORDER.DWG* in:
  - **Windows XP:** *Documents and Settings\{username}\My Documents\Acade\{version}\Aedata\Proj\Aegs*
  - **Windows Vista, Windows 7:** *Users\{username}\Documents\Acade\{version}\Aedata\Proj\Aegs*

This drawing contains a sample border without any of the attribute definition objects.





- 2 Zoom in for attribute definition placement.

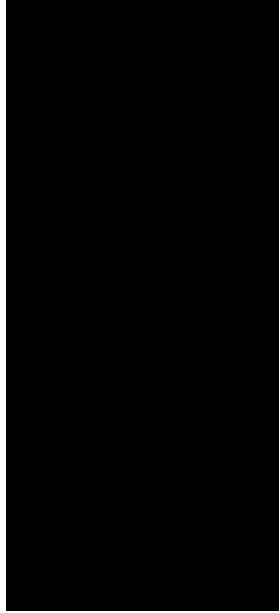

- 3 Enter *ATTDEF* at the command prompt to insert attribute definition objects.

---

**NOTE** When the border drawing is inserted as a block on another drawing, attribute definition objects become attributes.

---

- 4 Enter the Tag name SH#.

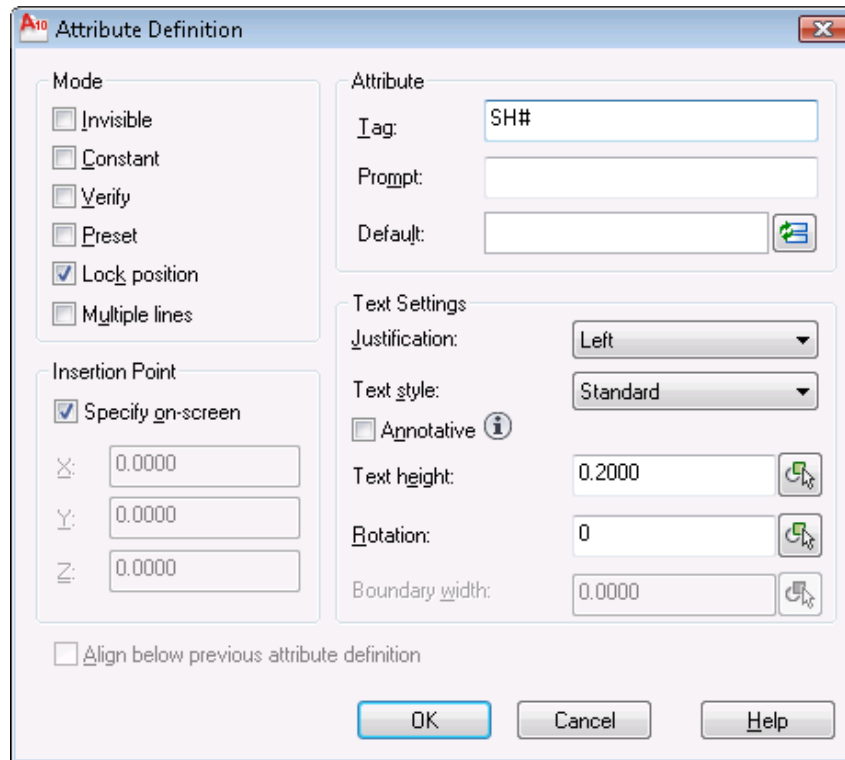

- 5 Set any other attribute definition properties and values, such as text style, height, and justification.
- 6 Select OK.
- 7 Specify the insertion point.

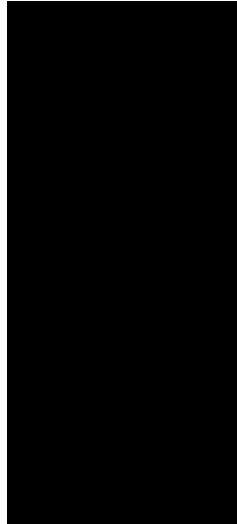

**8** Repeat for each attribute definition for the title block as shown.

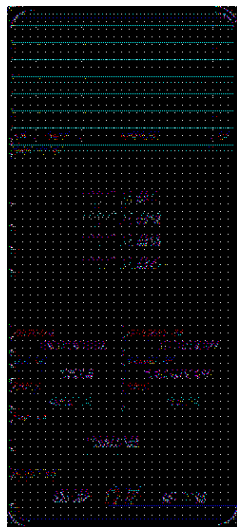

- 9** Enter *SAVEAS* at the command prompt.
- 10** Enter **File name:** acad\_title.
- 11** Select **Files of type:** AutoCAD Drawing (\*.dwg)
- 12** Click Save.

## Title Block Setup - WDT file method

A text file defines which AutoCAD Electrical values are mapped to the drawing title block attributes. Use the Title Block Setup utility to create or modify the *WDT* mapping file.

- 1 Click Project tab ► Project Tools panel ► Manager. 
- 2 If AEGS is not the active project, activate the AEGS project.  
If AEGS is in the list of open projects:
  - Select AEGS and right-click.
  - Click Activate.If AEGS is not in the list of open projects:
  - Select the project list drop-down.
  - Click Open Project.
  - On the Select Project File dialog box, navigate to and select the *AEGS.WDP* file.
  - Click Open.
- 3 Open the title block base drawing created previously, *ACADE\_TITLE.DWG*, that contains the attribute definition objects.

---

**NOTE** Title Block Setup, *WDT* file method, can also be used on a drawing with the title block inserted as a block.

---

- 4 Click Project tab ► Other Tools panel ► Title Block Setup. 
- 5 Select the title block link method: **Method 1: <Project> .WDT file.**  
A project-specific file, with the same name and location as the active project and a *WDT* extension, defines the attribute mapping.
- 6 Click OK.



7 Click Active Drawing.

---

**NOTE** If running Title Block Setup on a drawing with *ACADE\_TITLE* inserted as a block, select Pick Block and select on the block.

---

8 Click OK.

Title Block Setup reads the attribute definitions and the Title Block Setup dialog box displays. Each drop-down list contains all the attribute definition objects found on the drawing.

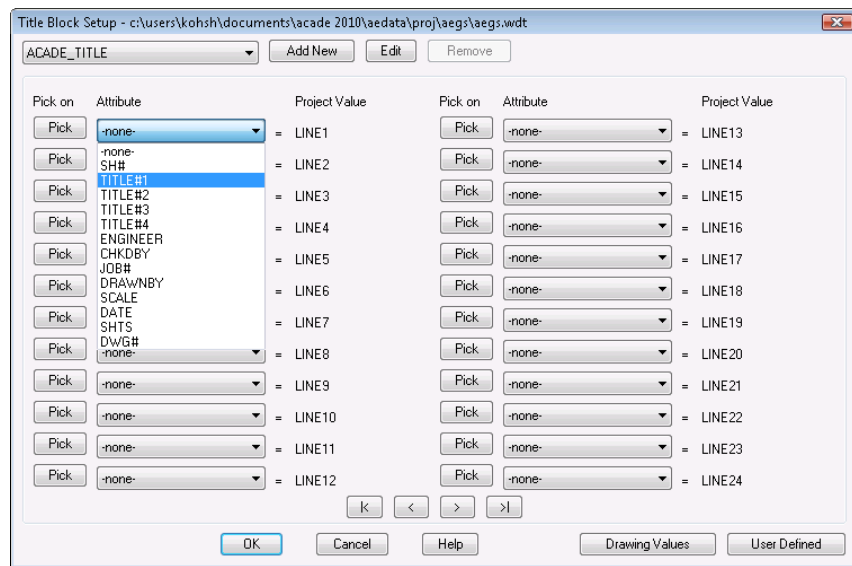

---

**NOTE** If no attribute definition objects are found on the drawing, an alert displays.

---

9 In the Title Block Setup dialog box, select the attribute from each list to map to its corresponding project description line.

TITLE#1 ► LINE1

TITLE#2 ► LINE2

JOB# ► LINE4

DRAWNBY ► LINE6

- 10 Click Drawing Values to assign drawing specific values.
- 11 Select the attribute from each list to map to its corresponding drawing value.
  - DWG# ► Drawing (%D value)
  - SH# ► Sheet (%S value)
  - SHTS ► Sheet Maximum
  - TITLE#3 ► Drawing Description 1
  - TITLE#4 ► Drawing Description 2
- 12 Click OK.
- 13 Title Block Setup creates *AEGS.WDT* with the selected mappings.



#### **Show Me: Title Block Setup - WDT file method**

Click the Play arrow to start the animation.

## **Create a drawing template**

A drawing template file is used to provide consistency in the drawings that you create by providing standard styles and settings.

When a drawing template file is used to start a new drawing it can:

- Predefine AutoCAD Electrical drawing properties such as component tagging, wire numbering format, and so on.
- Predefine layers and layer properties.
- Predefine wire layers.
- Provide your drawing border and title block.

By default, drawing template files are stored in the *template* folder, where they are easily accessible.

- 1 Enter *QNEW* at the command prompt to start a new drawing.
- 2 Select the *acad.dwt* template.
- 3 Click Open.
- 4 Enter *INSERT* at the command prompt.
- 5 Click Browse.
- 6 Navigate to and select the title block *ACADE\_TITLE.DWG* created for the border.
- 7 Click Open.
- 8 On the Insert dialog box, make sure the Explode option is not checked.
- 9 Click OK.
- 10 Specify the insertion point at 0,0,0.
- 11 If prompted for attribute values, leave them blank.

---

**NOTE** Attributes are invisible if no default values are assigned.

---

- 12 Click Schematic tab ► Other Tools panel ► Drawing Properties.



The alert displays.

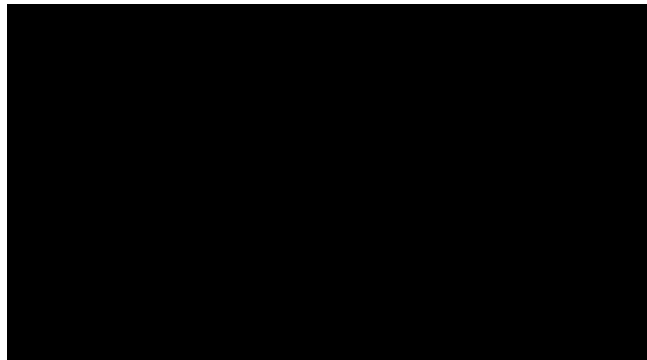

- 13 Click OK to insert the WD\_M block.
- 14 Set the default drawing properties such as component tagging, wire numbering, cross-referencing, and so on.

---

**NOTE** No specific changes are needed for this tutorial.

---

- 15 Click OK.
- 16 Click Schematic tab ► Edit Wires/Wire Numbers panel ► Create/Edit



Wire Type.

- 17 Add wire layers as needed. Set the properties, color, linetype, and linewidth for each layer. For example:
  - In the Create/Edit Wire Type dialog box, click inside the Wire Color column for a blank row and enter *RED* for a new wire layer.
  - Click inside the Size column and enter *12* for the size. The Layer Name *RED\_12* is automatically created.
  - Click Color.
  - Select Red and click OK.
  - Click OK. The layer is created and defined as a wire layer.
- 18 Enter *SAVEAS* at the command prompt.
- 19 Set the file type as AutoCAD Drawing Template (\*.dwt).
- 20 Enter the file name, *AEGS\_ELECTRICAL*.
- 21 Click Save. The Template Options dialog box displays.
- 22 Select OK.
- 23 Close the drawing, *AEGS\_ELECTRICAL.DWT*.



## Use the template

- 1 If AEGS is not the active project, in the Project Manager, right-click AEGS and select Activate.
- 2 In the Project Manager, click the New Drawing tool. 
- 3 In the Create New Drawing dialog box, specify:  
**Name:** AEGS11  
**Description 1:** Title Block  
**Description 2:** Exercise
- 4 Click Browse next to the Template edit box.
- 5 In the Select template dialog box, select *AEGS\_ELECTRICAL.dwt*, and click Open.
- 6 In the Create New Drawing dialog box, click OK.
- 7 On the Apply Project Defaults to Drawing Settings dialog box, click No. Project Manager creates the drawing using the template containing the title block.

## Project description lines

The Title Block Update utility can update attributes on your title block with the project description lines.

- 1 Click Project tab ► Project Tools panel ► Manager. 
- 2 If AEGS is not the active project, in the Project Manager, right-click AEGS and select Activate.
- 3 In the Project Manager, right-click the project name, and select Descriptions.
- 4 In the Project Description dialog box, enter values:  
**Line 1:** Tutorial Project  
**Line 2:** AutoCAD Electrical

**Line 4:** Job #01000

**Line 6:** {your name}

- 5 Click OK.

## Drawing values

The Title Block Update utility can update attributes on your title block with certain drawing property values.

- 1 In the Project Manager, double-click to expand the AEGS project.
- 2 Right-click on drawing AEGS11 and select Properties ► Drawing Properties.
- 3 Enter values:

**Sheet:** 11

**Drawing:** 0211

---

**NOTE** Drawing Description 1 and 2 were defined when the drawing was created.

---

- 4 Click OK.
- 5 Save the drawing.

## Title Block Update

- 1 If AEGS is not the active project, in the Project Manager, right-click AEGS and select Activate.
- 2 In the Project Manager, double-click to expand the AEGS project.
- 3 Double-click drawing AEGS11 to open it.

- 4 Click Project tab ► Other Tools panel ► Title Block Update.  
The Update Title Block dialog box displays.



- 5 Select the project and drawing values to update on the title block.
  - LINE1
  - LINE2
  - LINE4
  - LINE6
  - Drawing Description: 1 and 2
  - Drawing (%D value)
  - Sheet (%S value)
  - Sheet maximum
  - Resequence sheet %S values: 1

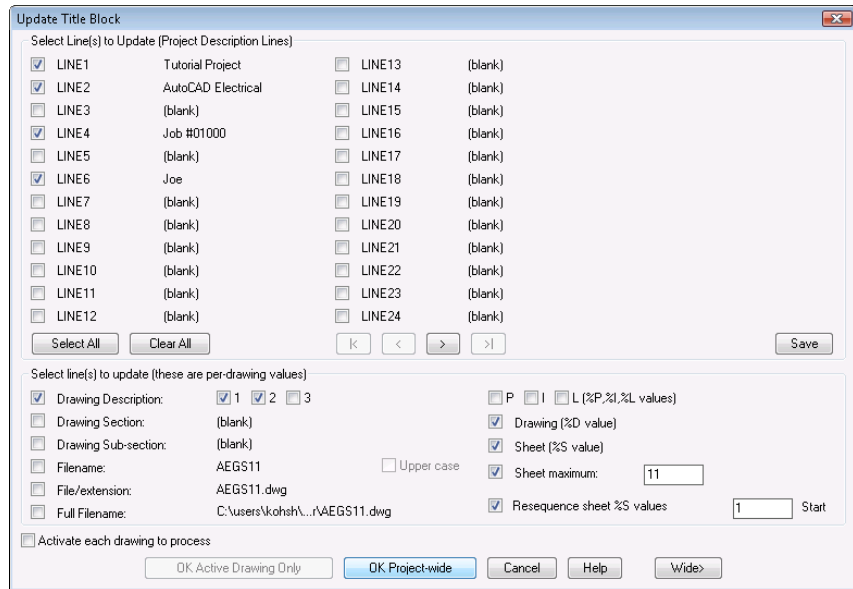

- 6 Click OK Project-Wide.
- 7 Select drawings AEGS06 through AEGS11 to process. Click Process v.

---

**NOTE** Drawings AEGS01 through AEGS05 are supplied with the WD\_TB attribute on the title block for this exercise.

---

- 8 Click OK.



## Customize project description labels

The title block and project description dialog boxes in AutoCAD Electrical display generic labels like “LINE1”, “LINE2”, and so on. You can change these labels so they match up with the link to the title block. For example, you have linked the AutoCAD Electrical data “LINE4” value to the “JOB#” attribute on the title block. What you want to see when AutoCAD Electrical displays a title block-related dialog box is not “LINE4” but “Job Number.” A text file with a *WDL* extension defines the custom labels.

- 1 Use any generic text editor like Notepad or Wordpad and start a new text file.
- 2 Enter the lines as shown:  
LINE1 = Title 1  
LINE2 = Title 2  
LINE3 = Title 3  
LINE4 = Job Number

LINE5 = Date  
LINE6 = Drawn By  
LINE7 = Engineer  
LINE8 = Checked By  
LINE9 = Scale

- 3 Save the file as *AEGS\_WDTITLE.WDL* in the project folder.
  - **Windows XP:** *Documents and Settings\{username}\My Documents\Acade{version}\Aedata\Proj\Aegs*
  - **Windows Vista, Windows 7:** *Users\{username}\Documents\Acade{version}\Aedata\Proj\Aegs*
- 4 Switch over to AutoCAD Electrical.



- 5 Click Project tab ► Project Tools panel ► Manager.
- 6 If AEGS is not the active project, in the Project Manager, right-click AEGS and select Activate.
- 7 In the Project Manager, right-click the project name, and select Descriptions.

The labels match the values in the *WDL* file.

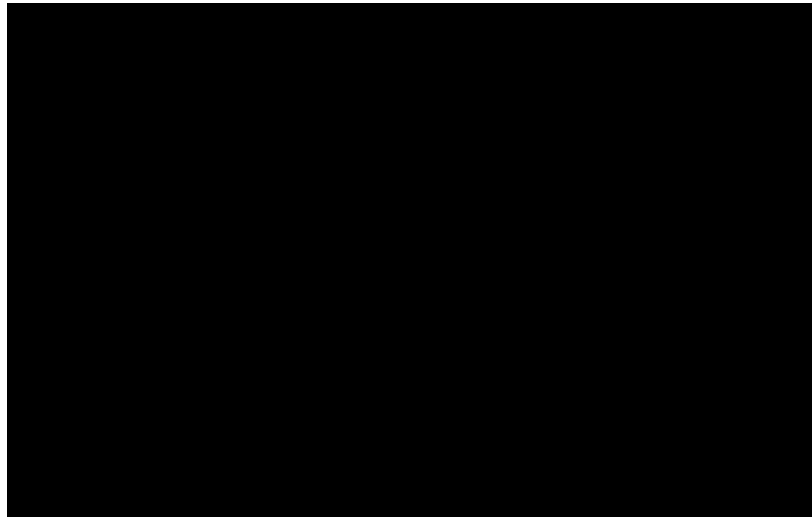

# Wiring

## Wiring - Introduction

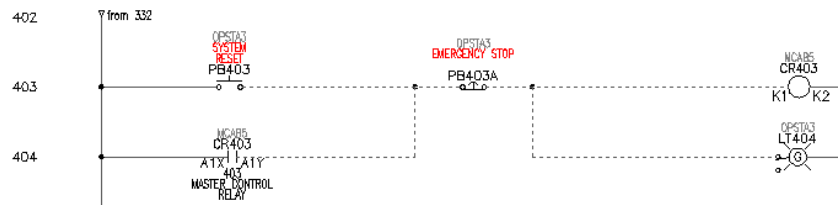

Insert and modify wires and ladders.

Time required 20 minutes

Prerequisites: Copy all files located in

**Windows XP** *Documents and Settings\{username}\My Documents\Acade {version}\Aedata\Tutorial\Aegs\Wiring*  
to  
*Documents and Settings\{username}\My Documents\Acade {version}\Aedata\Proj\Aegs*

**Windows Vista, Windows 7** *Users\{username}\Documents\Acade {version}\Aedata\Tutorial\Aegs\Wiring*  
to  
*Users\{username}\Documents\Acade {version}\Aedata\Proj\Aegs*

You learn to:

- Understand wires
- Insert wires
- Add ladder rungs
- Trim wires
- Insert a ladder
- Resequence ladder line reference numbers

## About wires

AutoCAD Electrical treats AutoCAD® line entities as wires when the lines are placed on an AutoCAD Electrical defined wire layer. The number of wire layers available in AutoCAD Electrical is unlimited. These lines get tagged with wire numbers and show up in various wire connection reports.

Two wire segments connect if the end of one wire segment touches or falls within a small trap distance of any part of the other wire segment. This connection can be at the end of the other wire or anywhere along the length of the other wire.

If the wire end falls within a trap distance from the wire connection-point attribute of a component, AutoCAD Electrical considers a wire connected to a component.

The following rules determine the wire layer for a new wire segment:

- Wires that begin or end in space, or begin and end at a component connection point. They are put on the current layer (if it is a wire layer), or on the first wire layer AutoCAD Electrical finds in a layer name search.
- Wires that begin at an existing wire are put on the same layer as the beginning wire.
- Wires that begin in space or at a component and end at an existing wire take on the layer of the ending wire.

## Insert wiring

You can start or end a wire segment in empty space, from an existing wire segment, or from an existing component. If you start from a component, the wire segment snaps to the wire connection terminal closest to your pick point on that symbol. If the wire segment ends at another wire segment, a DOT (block name *wddot.dwg*) is applied if appropriate. If it ends at another component, the segment connects to the wire connection terminal closest to your pick point on that symbol.

---

**NOTE** When inserting wires, if a wire already occupies a wire connection point, the new wire is drawn as an angled wire connection.

---

## Insert wiring

- 1 If AEGS is not the active project, in the Project Manager, right-click AEGS and select Activate.
- 2 In the Project Manager, double-click AEGS to expand the drawing list.
- 3 In the Project Manager, Project Drawing List, double-click *AEGS04.dwg*.
- 4 Zoom in on the upper left corner of the drawing. Make sure the hot and neutral vertical wires are displayed.
- 5 Click Schematic tab ► Edit Wires/Wire Numbers panel ► Modify Ladder



- 6 Respond to the prompts as follows:

Add rung passing through this location or [wiretype (T)]:

*Select a location between the two vertical bus wires beside line reference 403 (1)*

Add rung passing through this location or [wiretype (T)]:

*Select a location between the two vertical bus wires beside line reference 404, underneath the newly created rung (2), press ENTER*

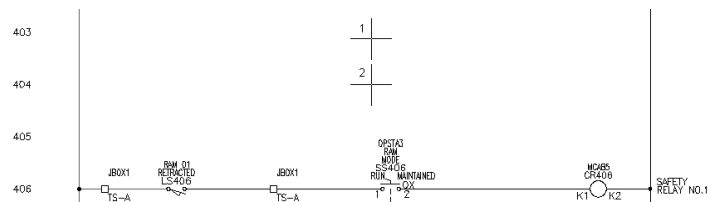

Two horizontal wires are created automatically between the vertical bus wires at the closest line reference location.

## Create two vertical wires between two horizontal wires

- 1 Click Schematic tab ► Insert Wires/Wire Numbers panel ► Insert Wires

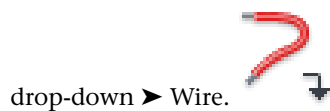

- 2 Respond to the prompts as follows:



Specify wire start or [wireType/X=show connections]:

*Select the top wire at line reference 403(1)*

Specify wire end or [V=start Vertical/H=start

Horizontal/Continue]: *Select the lower wire at line reference 404 (2)*

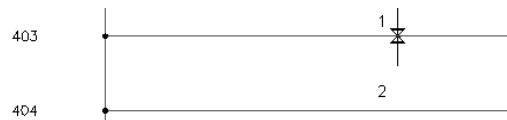

The color of temporary graphics changes for a new wire when AutoCAD Electrical can connect the wire to an existing wire.

Each component wire connection point displays as a green x at the wire connection when you enter X + ENTER during wire insertion. If you pan or zoom, repeat the command to view the wire connection points.

3 Insert another wire to the right of the new wire.

4 Press ENTER to exit the command.

The inserted wires resemble the following image.

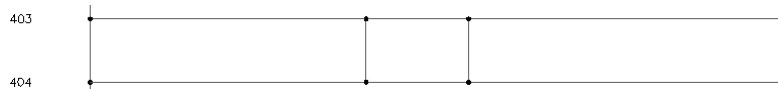

## Trim a wire

After you insert wires, you can trim them. The Trim Wire tool removes wire segments. You can trim single or multiple wires.

### Trim a wire

1 Click Schematic tab ► Edit Wires/Wire Numbers panel ► Trim Wire.



2 Respond to the prompts as follows:

Fence/Crossing/Zext/<Select wire to TRIM>:

*Specify the wire segment at line reference 404 between the two vertical wires (1), right-click*

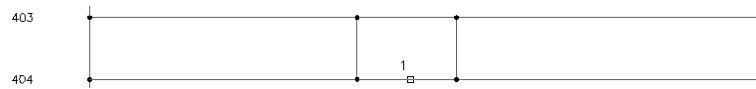

Wire segments are trimmed back to a connecting dot, a component, or completely if neither is encountered along the segment. Any connection dots that are no longer needed are removed.

The trimmed wire resembles the following image.

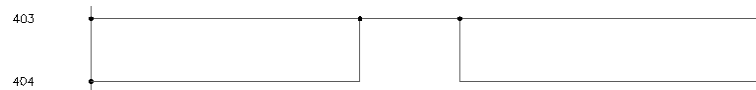

## Insert a single-phase ladder

You can insert a ladder into a drawing at any time. A drawing can have multiple ladders, as well as single-phase and three-phase ladders. The ladders can have different parameters, such as rung spacing, number of rungs, and ladder width.

### Insert a single-phase ladder

- 1 Open *AEGS05.dwg*.
- 2 Click Schematic tab ► Insert Wires/Wire Numbers panel ► Insert Ladder

drop-down ► Insert Ladder. 

- 3 In the Insert Ladder dialog box, specify:

Width: 9.000  
 Spacing: 1.0000  
 1st Reference: 519  
 Index: 1  
 Rungs: 18  
 Phase: 1 Phase  
 Draw Rungs: Yes  
 Skip: 0

You do not specify the Length since it is automatically calculated once the first Reference, Index, and Rungs are specified.

---

**NOTE** Reference 519 represents Page 5, Reference 19.

---

- 4 Click OK.
- 5 Respond to the prompts as follows:

Specify start position of first rung or [wireType]:

*Enter 16, 21 press ENTER*

---

**NOTE** You can also specify the start position of the first rung by left-clicking a location on the drawing with your mouse.

---

A single phase ladder is inserted in the drawing.

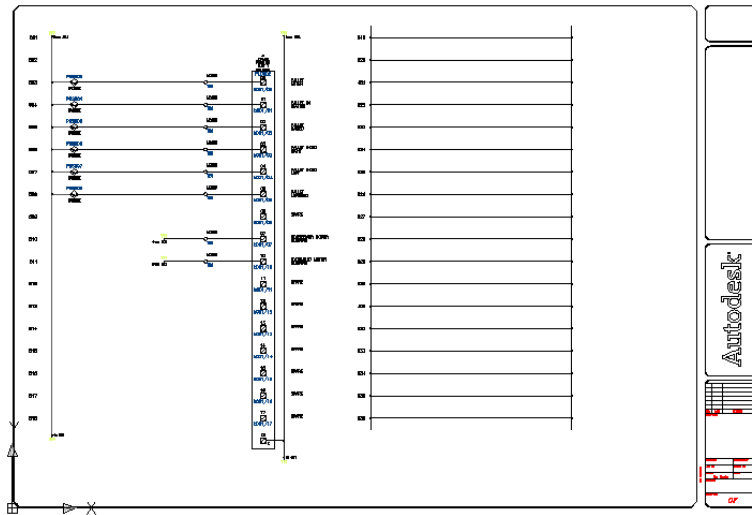

## Resequencing ladders

AutoCAD Electrical drawings can be easily renumbered and retagged with a minimum of manual clean-up. You can resequence line reference numbers, component tags, and wire numbers. It is useful when a drawing has been copied from a previous project and the line reference numbers and tagging format of the drawing do not conform to the project requirements.

## Resequence ladder line reference numbers

- 1 Click Schematic tab ► Edit Wires/Wire Numbers panel ► Modify Ladder



drop-down ► Revise Ladder.

The Modify Line Reference Numbers dialog box displays a list of ladders in the drawing.

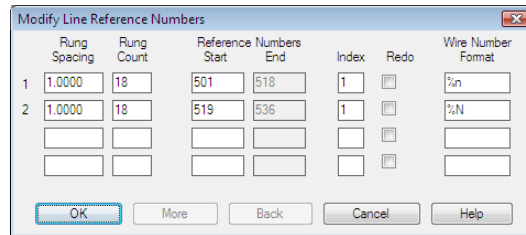

- 2 Change the beginning line reference numbers for each ladder. Change the first ladder to 101 (column 1, line 01) and the second ladder to 201 (column 2, line 01).

- 3 Click OK.

The reference numbers update along each ladder.

## Schematic components

### Schematic components - Introduction

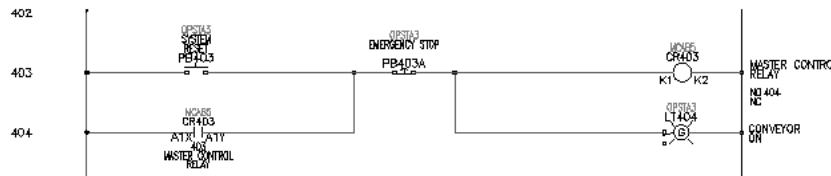

Insert and modify schematic components.

Time required 45 minutes

Prerequisites: Copy all files located in

<b>Windows XP</b>	<i>Documents and Settings\{username}\My Documents\Acade {version}\Aedata\Tutorial\Aegs\Schematic components</i> to <i>Documents and Settings\{username}\My Documents\Acade {version}\Aedata\Proj\Aegs</i>
<b>Windows Vista, Windows 7</b>	<i>Users\{username}\Documents\Acade {version}\Aedata\Tutorial\Aegs\Schematic components</i> to <i>Users\{username}\Documents\Acade {version}\Aedata\Proj\Aegs</i>

You learn to:

- Understand schematic components
- Insert a parent component
- Scoot a component
- Insert a child component
- Align components
- Edit a component
- Link components
- Edit catalog information
- Add a catalog entry

## About schematic components

An AutoCAD Electrical schematic component is an AutoCAD® block with certain expected attributes. When inserting components, use AutoCAD Electrical tools to:

- Break wires
- Assign unique component tags
- Cross-reference related components
- Enter values for catalog information, component descriptions, location codes, and so on

AutoCAD Electrical supplies a schematic symbol dialog box for finding and inserting schematic components. It also triggers some additional features.

- Automatic wire breaks
- Component tagging
- Real-time cross-referencing
- Component annotation

## Inserting components

AutoCAD Electrical employs a parent/child relationship for schematic components. The parent coil symbol and the child contact symbols represent a relay coil with a certain number of contacts. When the parent coil symbol is inserted, it is assigned a unique component tag. When the child contact symbols are inserted, the child is related to the parent and the parent tag is assigned to the child symbol.

In this exercise, you insert components on the wires previously defined in *AEGS04.dwg*.

### Insert a parent component

- 1 If AEGS is not the active project, in the Project Manager, right-click AEGS and select Activate.
- 2 In the Project Manager, double-click AEGS to expand the drawing list.
- 3 In the Project Manager, Project Drawing List, double-click *AEGS04.dwg*.
- 4 Zoom in on the upper left corner of the drawing.
- 5 Click Schematic tab ► Insert Components panel ► Insert Components



drop-down ► Icon Menu.

- 6 In the Insert Component: JIC Schematic Symbols dialog box, click Relays/

Contacts. 

- 7 In the JIC: Relays and Contacts dialog box, click Relay Coil. 

**8** Respond to the prompts as follows:

Specify insertion point:

*Position the component on the wire at line reference 403 near the neutral wire and click (1)*

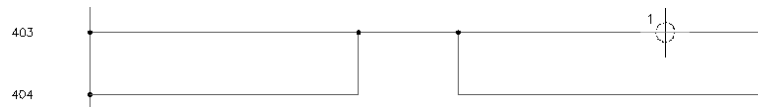

If you select directly on the wire or near to it, the coil symbol breaks the underlying ladder wire and reconnects. If the underlying wire did not break, you did not select close enough to the wire. To try again, click Cancel on the Insert/Edit Component dialog box. Right-click or press ENTER to repeat the command. Turning on Snap helps (0.125 is a good setting to use).

This tool inserts components into alignment with underlying wires, it does not align components side-to-side. If you want to insert components in neat columns, you have three options: use AutoCAD Snap when inserting components; use the Scoot command to move components and connected wires in place; or use the Align Component tool.

**9** In the Insert/Edit Component dialog box, verify that the Component Tag is set to CR403.

AutoCAD Electrical automatically determines the unique tag name for the new relay based on the line reference location that you inserted the symbol on. "CR" indicates that it is a control relay and "403" indicates that the symbol is on line reference 403. If you inserted this symbol on line reference 404 then the tag name would be "CR404."

You can assign a catalog number to the component that can be extracted into reports. There are two pieces of BOM catalog information: manufacturer code and catalog number. These values are carried as invisible attributes on the symbol. You can type in values for each or select the BOM information from an on-line catalog database file.

**10** In the Catalog Data section, click Lookup.



**11** On the Parts Catalog dialog box, click  to clear all predefined filters. Click Yes to confirm.

**12** On the Parts Catalog dialog box each column has an edit field to enter search text. Enter:

MANUFACTURER: AB

TYPE: TYPE P

COIL: 120VAC

- 13 Change the catalog assignment to 700-P200A1.

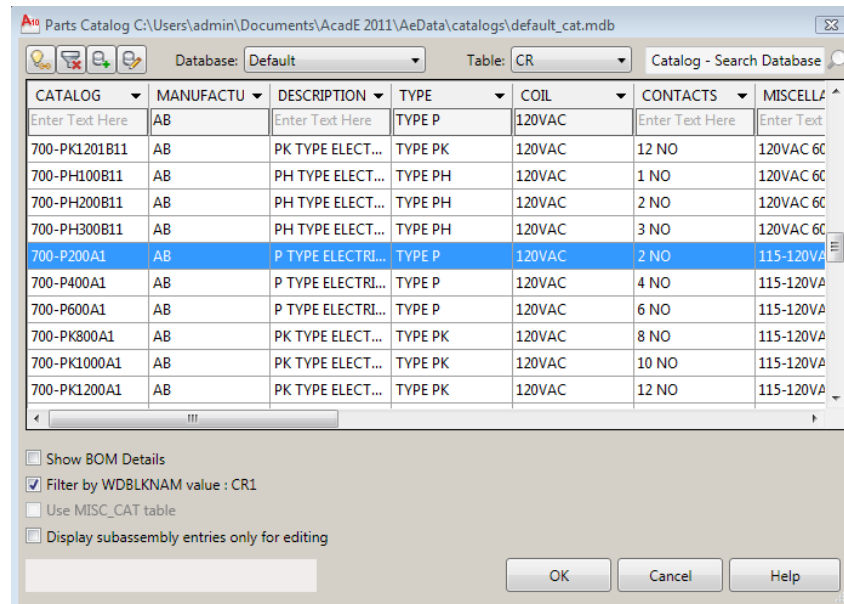

- 14 Click the Show BOM Details check box.

The dialog box expands to show the BOM information. Review the BOM information associated with the selected part number.

- 15 In the Parts catalog dialog box, click OK.

The selected manufacturer code and catalog number display in the Insert/Edit Component dialog box. When you click OK on the dialog box, the values transfer to the symbol.

---

**NOTE** Sample catalog information is provided with AutoCAD Electrical in Access Database format (.mdb). If your company uses its own internal coding system instead of manufacturer catalog numbers, substitute those numbers into catalog database files of AutoCAD Electrical. If you use your own system and reference a number of vendors, extra user fields are available in all the sample database files.

---



- 16** In the Insert/Edit Component dialog box, Description section, specify:

Line 1: MASTER CONTROL

Line 2: RELAY

Up to three lines of description text can be entered as a description for components. If the third description line is unavailable, the symbol does not carry an attribute for a third line of description.

---

**NOTE** You can specify a description by entering text or by clicking Defaults to select from a list of standard component descriptions.

---

- 17** In the Insert/Edit Component dialog box, Location code section, click Drawing.

AutoCAD Electrical does a quick read of the drawing file and returns a list of all location codes used so far.

- 18** In the All Locations - Drawing dialog box, select MCAB5 and click OK.

---

**NOTE** You can also include an external "LOC" location list in the project "LOC" list to help with consistency. To use this feature, create a file called *default.loc* and put it in an AutoCAD Electrical search directory. The format for this text file is each location on its own line in the file with no leading spaces. You can also create a project-specific file by naming it the same as your project but with a *.loc* extension.

---

- 19** In the Insert/Edit Component dialog box, the pin values are inserted based on the selected catalog number:

Pins: 1: K1

Pins: 2: K2

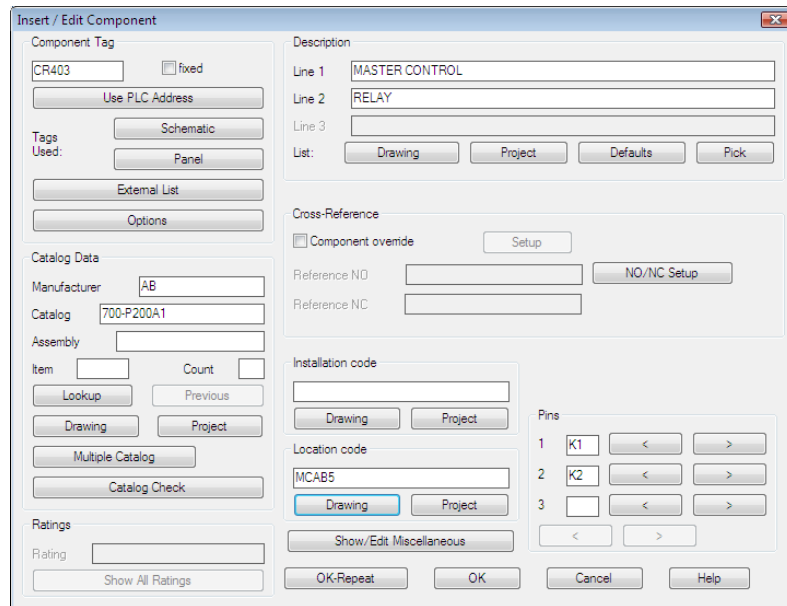

- 20 In the Insert/Edit Component dialog box, click OK.  
 Any values entered here are saved as attribute values on the symbol itself.

## Relocating components

If the component was not inserted in the correct location, you can scoot the component. Use the Scoot tool to select a component or wire number and slide it back and forth along the wire while keeping everything connected. You can select a wire or a whole rung of circuitry and scoot it to a new position. If there are any parent components among the scooted items, you are asked if you want to retag the scooted components.

The Scoot tool works on wire numbers, components, terminals, PLC I/O modules, jogs in dashed link lines, signal arrows, wires, and wires with wire-crossing loops.

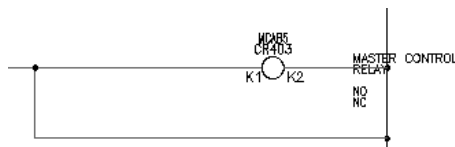

## Scoot a component

- 1 Click Schematic tab ► Edit Components panel ► Modify Components



drop-down ► Scoot.

- 2 Respond to the prompts as follows:

Select component, wire, or wire number for SCOOT:

*Select the component that was inserted at line reference 403*

The cursor changes to a box.

Select component, wire, or wire number for SCOOT: to

*Move the cursor to the right and click, right-click to exit the command*

The component moves to its new location.

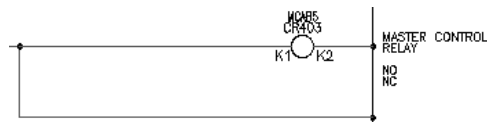

You can use the Scoot tool to grab a component or a wire number and slide it back and forth along a wire. You can grab a wire or a whole rung of circuitry and scoot it to a new position, while keeping everything connected.

The steps to insert a parent component and a child component are the same, except when you annotate the symbol.

## Insert a child component

- 1 Click Schematic tab ► Insert Components panel ► Insert Components



drop-down ► Icon Menu.

- 2 In the Insert Component: JIC Schematic Symbols dialog box, click Relays/

Contacts. 

- 3 In the JIC: Relays and Contacts dialog box, click Relay NO Contact. ||

4 Respond to the prompts as follows:

Specify insertion point:

Position the cursor on the wire at line reference 404 near the hot wire and click (1)

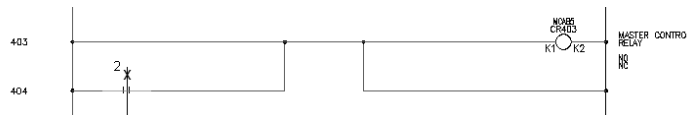

The Insert/Edit Child Component dialog box displays. Notice that AutoCAD Electrical did not automatically assign a tag name for the relay contact; there is just a generic “CR” in the edit box. Determine the relay contact tag name. A relay contact is a child component that must link to a parent relay coil on a drawing in the active project. The child gets the same tag name that is found on the parent relay coil.

Assign the tag name by clicking Parent/Sibling and picking the parent in the drawing. Or, click Drawing or Project to select from a list of components with the same family name.

5 In the Insert/Edit Child Component dialog box, Component Tag section, click Drawing.

6 In the Active Drawing list for FAMILY=“CR” dialog box, select: MCAB5 CR403 MASTER CONTROL RELAY

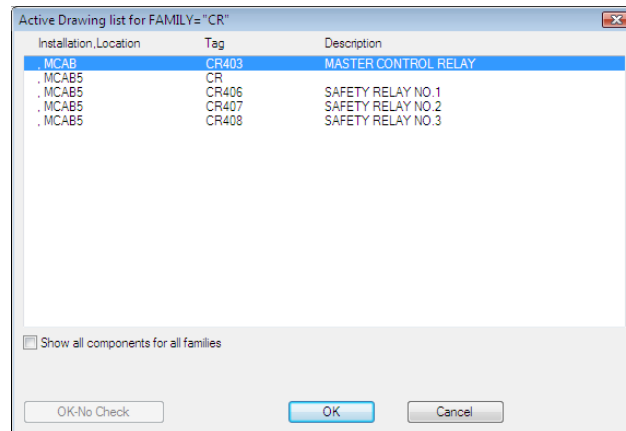

7 Click OK.

The values of the parent are immediately transferred to the contact.

- 8 In the Insert/Edit Child Component dialog box, verify that the following options are specified:

Component Tag: CR403

Description: Line 1: MASTER CONTROL

Description: Line 2: RELAY

Cross-reference: 403

Location code: MCAB5

Pins: Pin 1: A1X

Pins: Pin 2: A1Y

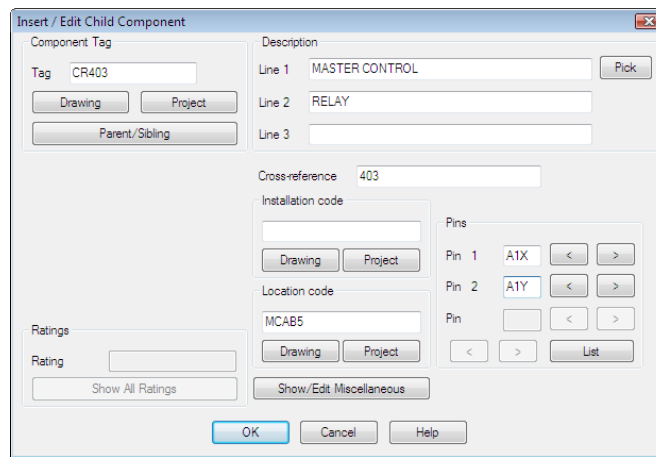

- 9 In the Insert/Edit Child Component dialog box, click OK.

The child component is inserted. It is cross-referenced in real time. The coil is annotated with the line reference number of the new child contact. The child contact gets annotated with the line reference location of the parent coil.

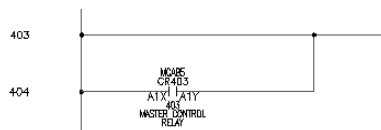

## Aligning components

Align the normally open relay contact with an existing component. After you insert a component, you can align or edit it as necessary.

### Align a component

- 1 Click Schematic tab ► Edit Components panel ► Modify Components

drop-down ► Align. 

- 2 Respond to the prompts as follows:

Pick component to align with (Horizontal/<Vertical>):

*Select the normally open limit switch component near the hot wire at line reference 406 (1)*

A dashed line displays.

Select objects:

*Select the previously inserted child contact component near the hot wire at line reference 404 (2), right-click*

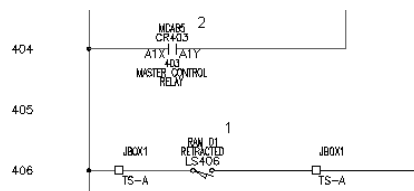

The aligned component is placed.

## Inserting components continued

Now you insert a system reset push button, pilot light, and an emergency stop push button to make up the circuit.

## Insert a system reset button

- 1 Click Schematic tab ► Insert Components panel ► Insert Components



drop-down ► Icon Menu.

- 2 In the Insert Component: JIC Schematic Symbols dialog box, click Push



Buttons.

- 3 In the JIC: Push Buttons dialog box, click Push Button NO.



- 4 Respond to the prompts as follows:

Specify insertion point:

*Position the push button on the wire at line reference 403 near the hot wire and click (1)*

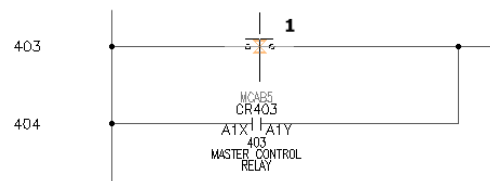

- 5 In the Insert/Edit Component dialog box, verify the following:

Component Tag: PB403

AutoCAD Electrical automatically assigned the tag name based on the line reference.

- 6 In the Descriptions section, specify:

Line 1: SYSTEM

Line 2: RESET

- 7 In the Location code section, click Drawing.

- 8 In the All Locations - Drawing dialog box, select OPSTA3 and click OK.

- 9 In the Insert/Edit Component dialog box, click OK.

## Insert a pilot light

- 1 Click Schematic tab ► Insert Components panel ► Insert Components



drop-down ► Icon Menu.

- 2 In the Insert Component: JIC Schematic Symbols dialog box, click Pilot

Lights. 

- 3 In the JIC: Pilot Lights dialog box, click Green Press to Test. 

- 4 Respond to the prompts as follows:

Specify insertion point:

*Position the pilot light on the wire at line reference 404 near the neutral wire and click (2)*

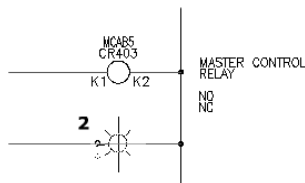

---

**TIP** Having Snap turned on makes positioning the pilot light easier.

---

- 5 In the Insert/Edit Component dialog box, verify:

Component Tag: LT404

- 6 In the Descriptions section, specify:

Line 1: CONVEYOR

Line 2: ON

- 7 In the Location code section, click Drawing.

- 8 In the All Locations - Drawing dialog box, select OPSTA3 and click OK.

- 9 In the Insert/Edit Component dialog box, click OK.



## Insert a push button for emergency stop

- 1 Click Schematic tab ► Insert Components panel ► Insert Components



drop-down ► Icon Menu.

- 2 In the Insert Component: JIC Schematic Symbols dialog box, click Push

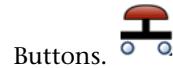

Buttons.

- 3 In the JIC: Push Buttons dialog box, click Mushroom Head NC.



- 4 Respond to the prompts as follows:

Specify insertion point:

*Position the push button on the middle of the wire at line reference 403 and click (3)*

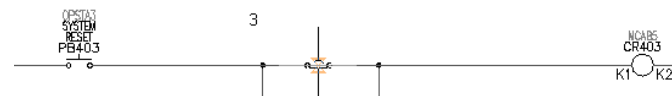

- 5 In the Insert/Edit Component dialog box, verify:

Component Tag: PB403A

AutoCAD Electrical automatically assigned the tag name based on the line reference. It added the "A" suffix since it is your second push button on this line reference.

- 6 In the Descriptions section, specify:

Line 1: EMERGENCY STOP

- 7 In the Location code section, click Drawing.

- 8 In the All Locations - Drawing dialog box, select OPSTA3 and click OK.

- 9 In the Insert/Edit Component dialog box, click OK.

Your finished schematic resembles the following:

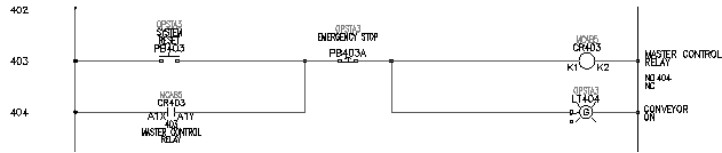

## Editing components

You can go back to a component at any time and change it. You can change description, tag, catalog number, location code, terminal numbers, and rating values using the Edit Component tool.

### Insert a child contact

- 1 Zoom in on the blank ladder rung at line reference 410.
- 2 Press F9 to turn on SNAP .
- 3 Click Schematic tab ► Insert Components panel ► Insert Components



drop-down ► Icon Menu.

- 4 In the Insert Component: JIC Schematic Symbols dialog box, click Selector Switches. 

- 5 In the JIC: Selector Switches dialog box, click 2nd+ NC Contact. 
- 6 Respond to the prompts as follows:

Specify insertion point:

*Position the selector switch at line reference 410 near the left side of the ladder and click (1)*

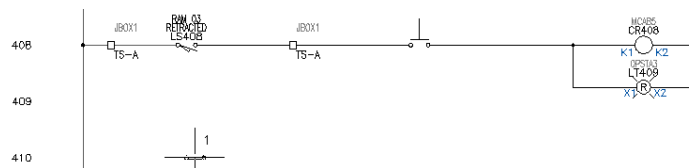

7 In the Insert/Edit Child Component dialog box, click OK.

## Insert a pilot light

1 Click Schematic tab ► Insert Components panel ► Insert Components



drop-down ► Icon Menu.

2 In the Insert Component: JIC Schematic Symbols dialog box, click Pilot



Lights.

3 In the JIC: Pilot Lights dialog box, click Blue Press to Test.



4 Respond to the prompts as follows:

Specify insertion point:

*Position the pilot light at line reference 410 near the neutral wire but exactly in line with the selector switch and click (2)*

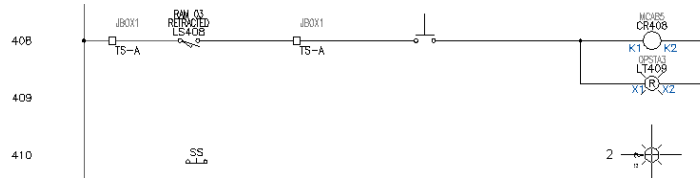

5 In the Insert/Edit Component dialog box, verify:

Component Tag: LT410

6 In the Descriptions section, specify:

Line 1: MAINT

Line 2: MODE

7 In the Insert/Edit Component dialog box, click OK.

## Edit a child contact

1 Press F9 to turn off SNAP .

- Click Schematic tab ► Edit Components panel ► Edit Components



drop-down ► Edit.

---

**NOTE** You can also right-click on a component and select Edit Component from the context menu.

---

- Respond to the prompts as follows:

Select component/cable/location box to EDIT:

Select the selector switch on line reference 410

- In the Insert/Edit Child Component dialog box, Component Tag section, click Parent/Sibling.

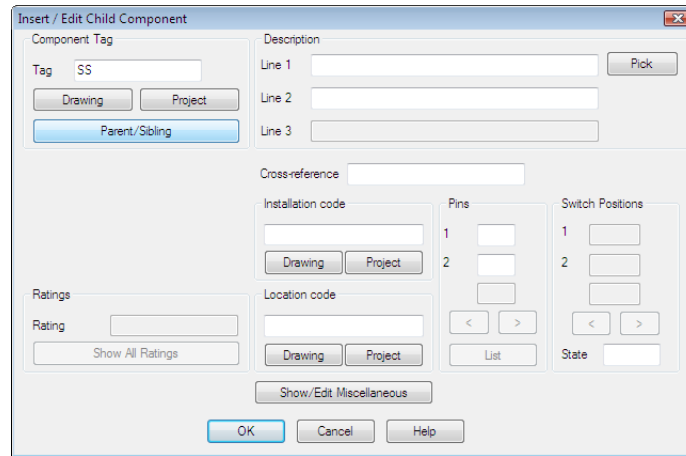

- Respond to the prompts as follows:

Select component:

Select the bottom sibling contact (3) of the existing switch on line reference 408

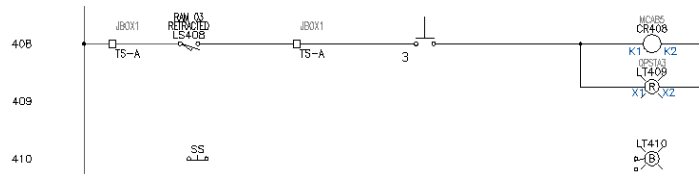

AutoCAD Electrical reads the sibling contact and transfers the appropriate annotation to your new switch contact.

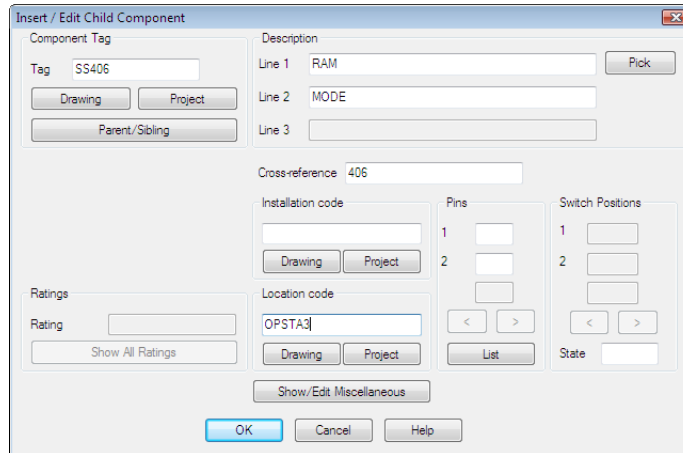

- 6 In the Insert/Edit Child Component dialog box, click OK. The sibling contact information displays on the drawing.

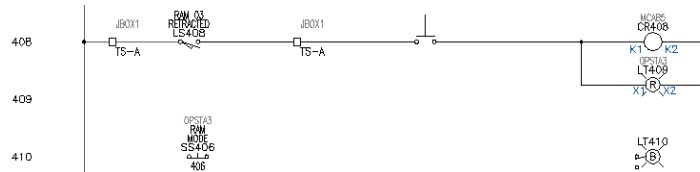

## Linking components

In this exercise, you link the selector switch you inserted to the existing RAM MODE selector switch residing on line reference 406 through 408 using dashed link lines.

### Connect components using wires

- 1 Click Schematic tab ► Insert Wires/Wire Numbers panel ► Insert Wires

drop-down ► Wire. 

- 2 Respond to the prompts as follows:

Specify wire start or [wireType/X=show connections]:

*Click the wire connection point on the right-hand side of the switch contact (4)*

Specify wire end or [Continue]:

*Drag the wire to the right and click the wire connection point on the left-hand side of the blue pilot light (5)*



Specify wire start or [Scoot/wireType/X=show connections]:

*Click the left-hand side of the switch contact*

Specify wire end or [Continue]:

*Drag the wire to the left and click the left-hand vertical bus wire*

The wire automatically ends on the bus and inserts a wire connection dot.

- 3 Repeat the process to connect the right-hand side of the blue pilot light to the vertical bus wire.
- 4 Right-click and select Enter to finish creating the wire connections.



If you lay a wire over the top of a series of components, AutoCAD Electrical automatically breaks and reconnects to the underlying wire connection points.

## Link components

- 1 Click Schematic tab ► Insert Components panel ► Dashed Link Line



drop-down ► Link Components with Dashed Line.

- 2 Respond to the prompts as follows:

Component to link from:

*Click the contact of the switch on line reference 408 (6)*

Component to link to:

*Click anywhere on your new switch contact (7), right-click*

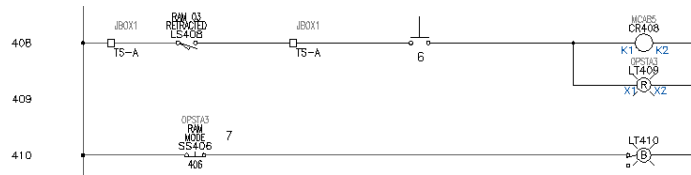

The annotation of the contact is changed to invisible. A dashed link line is drawn from the bottom of the upper contact to the top of your new contact.

Your finished schematic resembles the following:

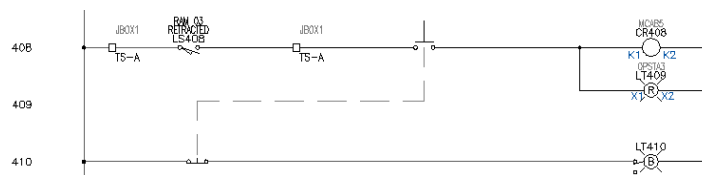

**NOTE** The Scoot command is fully compatible with dashed line links. Scooting one contact left or right causes both links to update automatically. You can even scoot the horizontal “jog” in the dashed link line up or down.

## Editing catalog information

Sample catalog information is supplied with AutoCAD Electrical. The information is held in tables in an Access Database file (.mdb) that is populated with sample vendor data.

You can use filter criteria in the catalog lookup to display catalog numbers selectively for a component type.

### Filter catalog data

- 1 Right-click LT410 and select Edit Component.
- 2 In the Insert/Edit Component dialog box, Catalog Data section, click Lookup.



- 3 On the Parts Catalog dialog box, click  to clear all predefined filters. Click Yes to confirm.

- 4 On the Parts Catalog dialog box each column has an edit field to enter search text. Enter:

Manufacturer: AB

Type: 30.5mm

Voltage: 120VAC XFMR

Each column also has a drop-down list containing the available field values. You can set the filter criteria to get a different set of catalog numbers. Each time you make a selection from one of these lists, the catalog selection is filtered.

**NOTE** If there are too many unique values to display, the list is not available.

- 5 Change the catalog assignment to 800T-PT16E.

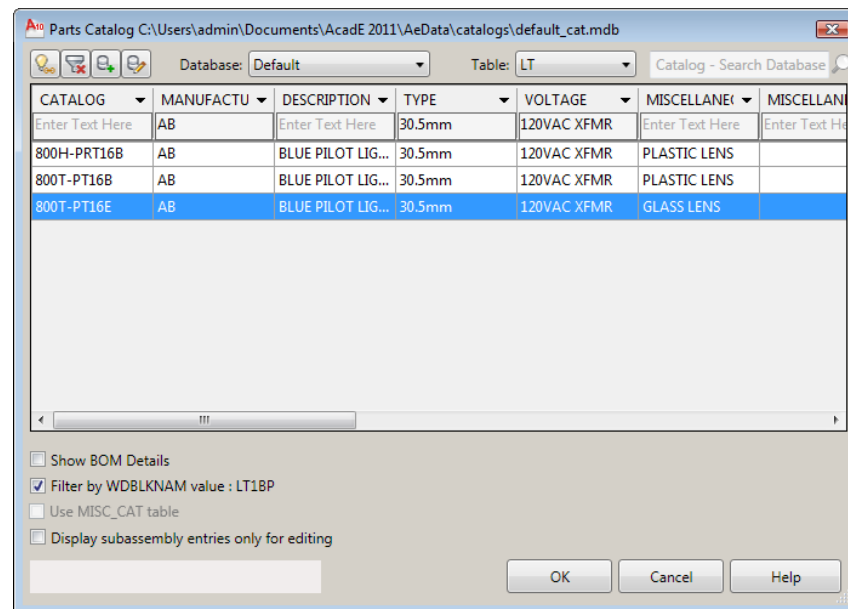

## Add a catalog entry

- 1 In the Parts Catalog dialog box, click Add Catalog Entry.





The entries are prefilled with the information for the currently assigned catalog part number. It is easy to add a new entry with similar information.

**2** In the Add Catalog Record dialog box, specify:

Catalog: BOG-123B

Manufacturer: BOGUS

The catalog lookup works most efficiently when field values that are meant to be the same are the same in both spelling and capitalization. The drop-down list for each field helps you maintain consistency as you add new catalog items.

**3** Click the drop-down list for the Description field.

AutoCAD Electrical does a quick scan of the existing catalog file. It collects and displays a list of all the different description field values found in the catalog.

**4** Select BLUE PILOT LIGHT - PRESS TO TEST, NEMA 4/13 and click OK.

**5** In the Add Catalog Record dialog box, click the drop-down lists for Type, Voltage, and Miscellaneous fields. Select the values shown in the following image if not already selected.

AutoCAD Electrical provides three blank user fields for your own internal use. Each can be a maximum of 24 characters wide and are extracted into BOM reports along with all the other fields.

---

**NOTE** You can add catalog entries with a subassembly. To link a subassembly with the main, the catalog part numbers share the same codes. In the Edit Catalog Record dialog box, select *As main->sub*, enter the ASSYCODE, and click OK. The ASSYCODE must be unique since it links the main catalog item with subassembly items. To add the subassembly item, in the Add Catalog Record dialog box, create a catalog entry, select *As sub*, enter an ASSEMBLYLIST code, and click OK.

---

- 6 In the Add Catalog Record dialog box, click OK.  
As the new entry is being added to the file, the Parts Catalog dialog box displays.
- 7 In the Parts Catalog dialog box, select the BOG-123B catalog entry and click OK.
- 8 In the Insert/Edit Component dialog box, click OK.

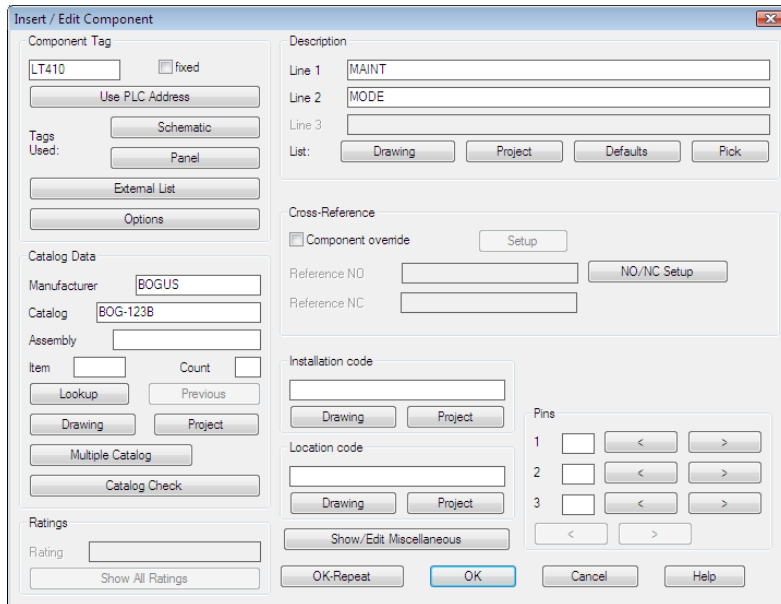

## Wire layers

### Wire layers - Introduction

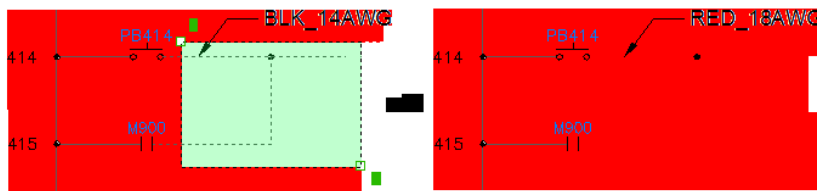

Create and modify wire layers.

**Time required** 10 minutes

**Prerequisites:** Copy all files located in

**Windows XP** *Documents and Settings\{username}\My Documents\Acade {version}\Aedata\Tutorial\Ae-  
gs\Wire layers*

to  
*Documents and Settings\{username}\My Documents\Acade {version}\Aedata\Proj\Aegs*

**Windows Vista,** *Users\{username}\Documents\Acade {version}\Aedata\Tutorial\Aegs\Wire layers*  
**Windows 7** to  
*Users\{username}\Documents\Acade {version}\Aedata\Proj\Aegs*

You learn to:

- Create wire layers
- Change wire layer assignments

## Creating a wire layer

### Create wire layer

- 1 If AEGS is not the active project, in the Project Manager, right-click AEGS and select Activate.
- 2 In the Project Manager, double-click AEGS to expand the drawing list.
- 3 In the Project Manager, Project Drawing List, double-click *AEGS04.dwg*.
- 4 Click Schematic tab ► Edit Wires/Wire Numbers panel ► Modify Wire



Type drop-down ► Create/Edit Wire Type.

The Create/Edit Wire Type dialog box lists all the valid wire layers that are defined for the active drawing. The wire layer name and the wire properties like color, size, and user-defined properties are listed in the grid.

- 5 Click inside the Wire Color column for a blank row and enter BLU as the wire color.
- 6 Click inside the Size column and enter 14AWG as the size.  
The Layer Name is automatically created.

	Used	Wire Color	Size	Layer Name	Wire Numbering	USER1	USER2
1	X	BLK	14AWG	BLK_14AWG	Yes		
2	X	RED	18AWG	RED_18AWG	Yes		
3	X	WHT	16AWG	WHT_16AWG	Yes		
4		BLU	14AWG	BLU_14AWG	Yes		
5							

- Click Color in the Layer section. Select blue and click OK.

---

**NOTE** If you want the new wire layer to be the default, click Mark Selected as Default.

---

- Click OK.

## Changing a wire layer assignment

When a wire is inserted, the wire ends up on the first valid wire layer as defined in the Drawing Properties dialog box. You can place wires on different wire layers. You can use the AutoCAD® PROPERTIES command to move a wire to the correct layer or you can use the Wire Layer utility.

### Change wire layer assignments

- Zoom in on the upper left corner of the drawing.
- Click Schematic tab ► Edit Wires/Wire Numbers panel ► Modify Wire



Type drop-down ► Change/Convert Wire Type.

The Change/Convert Wire Type dialog box lists all the valid wire layers that are defined for the active drawing. The wire layer name and the wire properties like color, size, and user-defined properties are listed in the grid. An “X” in the Used column indicates the layer name is currently being used.

- Select RED\_18AWG.

The wire type highlights in blue in the dialog box indicating that it is the wire type to change.

	Used	Wire Color	Size	Layer Name	Wire Numbering	USER1	USER2
1	X	BLK	14AWG	BLK_14AWG	Yes		
2	X	RED	18AWG	RED_18AWG	Yes		
3	X	WHT	16AWG	WHT_16AWG	Yes		
4							

- 4 Click OK.
- 5 Respond to the prompts as follows:

Select Objects:

*Window from left to right around the wires as shown and press ENTER*

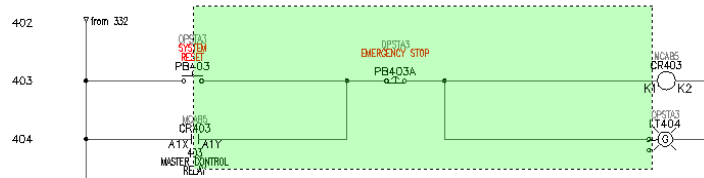

Before you press ENTER, the wires display as dashed lines to indicate that they have been selected. Once you press ENTER the lines display in red indicating that they have been moved to the RED\_18AWG wire layer.

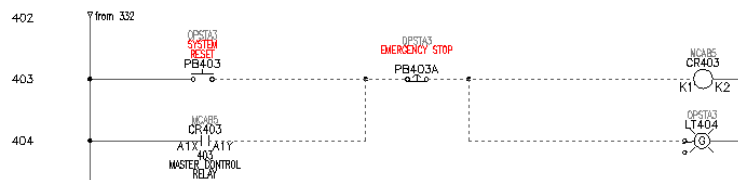

- 6 Repeat to move any other wiring onto another wire layer.

## Circuits

### Circuits - Introduction

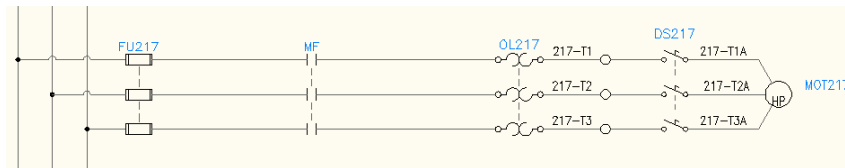

Create circuits with Circuit Builder. Save and insert a saved circuit.

Time required 60 minutes

Prerequisites:	Copy all files located in
<b>Windows XP</b>	<i>Documents and Settings\{username}\My Documents\Acade {version}\Aedata\Tutorial\Aegs\Circuits</i> to <i>Documents and Settings\{username}\My Documents\Acade {version}\Aedata\Proj\Aegs</i>
<b>Windows Vista, Windows 7</b>	<i>Users\{username}\Documents\Acade {version}\Aedata\Tutorial\Aegs\Circuits</i> to <i>Users\{username}\Documents\Acade {version}\Aedata\Proj\Aegs</i>

You learn to:

- Move a circuit
- Insert a circuit using Circuit Builder
- Save and insert a saved circuit
- Insert a saved circuit using WBLOCK

## Move an existing circuit

When you move a circuit, most of the parent components contained in the circuit automatically re-tag since the drawing is set up for reference-based component tagging. In the process of moving the circuit, you change the reference locations of the moved components. Related child components update to match the new parent tags, including references on other drawings in the project.

---

**NOTE** Tagging updates vary depending on your default tagging configurations.

---

### Move the location of a circuit

- 1 If AEGS is not the active project, in the Project Manager, right-click AEGS and select Activate.
- 2 In the Project Manager, double-click AEGS to expand the drawing list.
- 3 In the Project Manager, Project Drawing List, double-click *AEGS02.dwg*.
- 4 Zoom in on the lower left corner of the drawing. Make sure the 3-phase motor circuit at line reference 215 is visible.

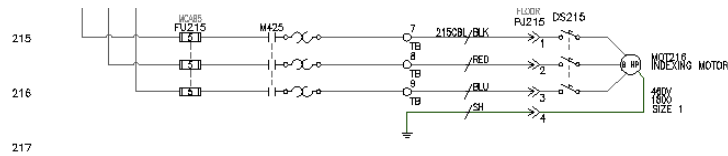

This circuit has component tags

- “FU215” on the 3-pole fuse
- “215CBL” on the multi-conductor cable
- “DS215” on the disconnect switch
- “MOT216” on the motor

5 Click Schematic tab ► Edit Components panel ► Circuit



drop-down ► Move Circuit.

6 Respond to the prompts as follows:

Select Objects:

*Window select the circuit on line reference 215 to capture the connection wire and dots that tie in to the vertical bus, right-click*

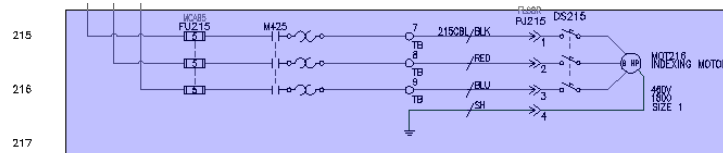

Press F9 to turn on SNAP .

Specify base point or displacement:

*Select a base point and then select a point on line reference 214*

The circuitry is moved, the affected components are retagged, and cross-references are updated based on the new line reference. Each of the listed parent component tags decrement by one. For example, fuse FU215 became FU 214.



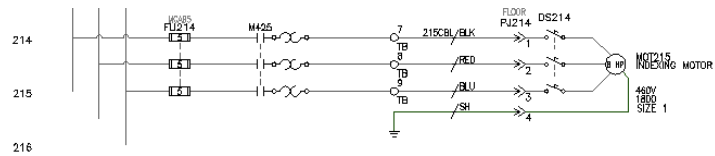

7 In the Update Related Components dialog box, click Yes-Update.

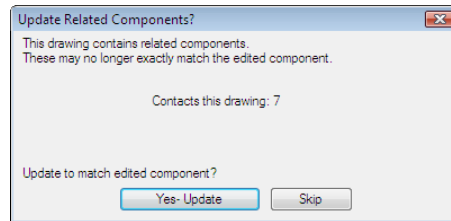

Related child references on the active drawing update to match the newly retagged parent components.

8 In the Update other drawings dialog box, click OK.

Related child components and panel layout references on other drawings update to match the parent components on the moved circuit.

9 If asked to save the drawing, click OK.

10 Click Project tab ► Other Tools panel ► Surfer drop-down ► Surfer.



11 Select FU214 on the drawing.

The Surf dialog box displays three references on sheet 2 and one reference on sheet 9.

12 Double-click the reference on Sheet 9.

Surfer goes to the panel layout drawing and zooms in on the physical representation of this 3-pole fuse. Notice that the physical representation of the fuse block tag updated because the circuit was moved.

13 Double-click the first entry in the dialog box to return to the original AEGS02.dwg drawing.

14 Click Close.

Moving the motor circuit up one line reference spacing opened up a bit more room to add a new circuit below it. The next step is to extend the 3-phase bus down to line reference 218 and over to the right to begin building a new motor circuit.

## Extending the 3-phase bus

- 1 Click Schematic tab ► Edit Wires/Wire Numbers panel ► Trim Wire.



- 2 Respond to the prompts as follows:

Fence/Crossing/Zext/<Select wire to TRIM>:

*Click the bottom ends of the three dangling wires, right-click*

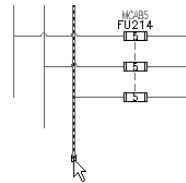

You can insert vertical or horizontal 3-phase wiring. Three-phase wiring automatically breaks and reconnects to any underlying components that it finds in its path. If it crosses any existing wiring, wire-crossing gaps are inserted.

- 3 Click Schematic tab ► Insert Wires/Wire Numbers panel ► Multiple



Bus.

- 4 In the Multiple Wire Bus dialog box, select:

Horizontal Spacing: 0.5

Vertical Spacing: 0.5

Starting at: Another Bus (Multiple Wires)

Number of Wires: 3

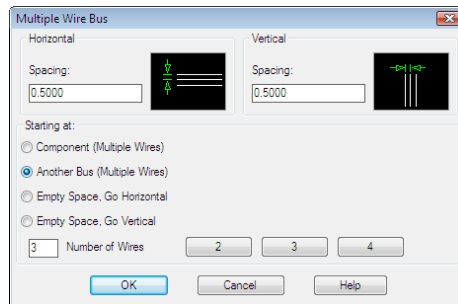

5 Click OK.

6 Respond to the prompts as follows:

Select existing wire to begin multi-phase bus connection:

Select the bottom corner of the left-most vertical bus on line reference 214 as shown

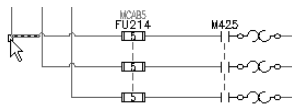

Select existing wire to begin multi-phase bus connection: to

Pull the cursor down to line reference 218.

Temporary graphics show the proposed routing of the extended bus.

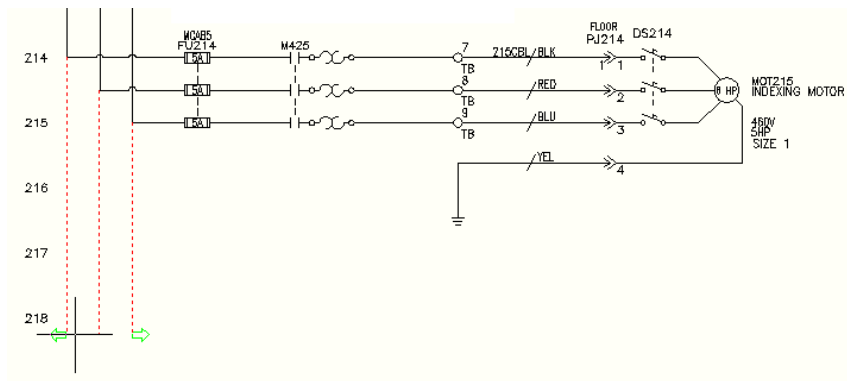

7 Click to create the wires.

8 Right-click to exit the command.

The 3-phase bus and wire connection dot symbols are inserted on the drawing.

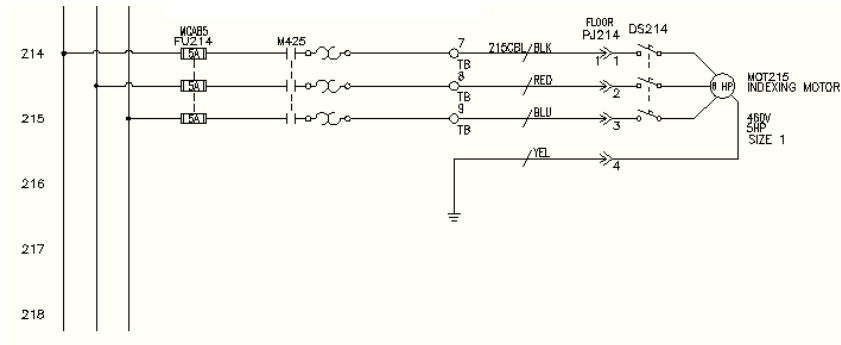

## Insert and configure a circuit

You now construct a new motor circuit on the extended 3-phase bus.

### Insert and configure the circuit

- 1 Click Schematic tab ► Insert Components panel ► Circuit Builder



drop-down ► Circuit Builder.

- 2 The Circuit Selection dialog box displays.

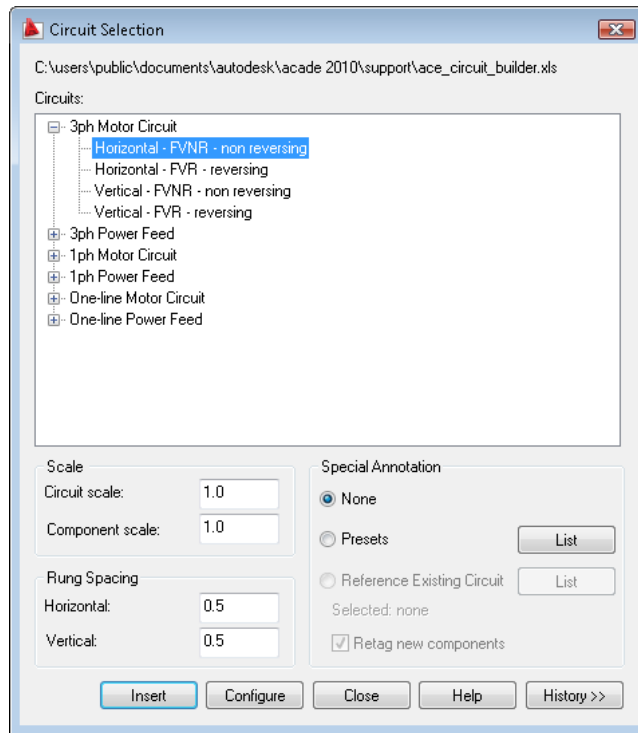

- 3 Expand 3ph Motor Circuit.
- 4 Select **Horizontal - FVNR - non reversing**.
- 5 Change the Rung Spacing: Horizontal to **0.5**.
- 6 Select Configure.
- 7 Specify insertion point at rung 217.

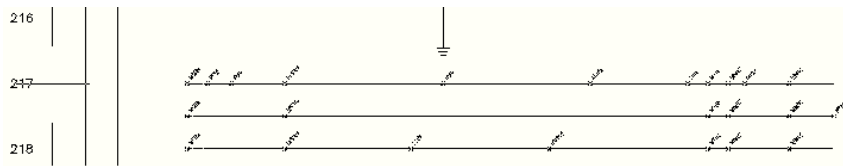

## Circuit Configuration

A circuit is made up of individual circuit elements and the wiring that connects them. Circuit Builder inserts a template drawing. This template contains the base wiring for the circuit and strategically positioned “marker blocks”.

The “marker blocks” control what circuit elements are presented in the Circuit Configuration dialog box. For example, a “marker block” indicates the need for a Disconnecting Means in the circuit. Various options for the Disconnecting Means are presented in the dialog box. The option selected for this circuit element is inserted at the location of the “marker block”. Circuit Builder dynamically builds the complete circuit based on the selections you make on this dialog box.

- 1 In the Circuit Elements section, select **Motor symbol**.  
In the Select section, select Motor: **3ph motor**,  
Ground/PE wire connection: **No**.

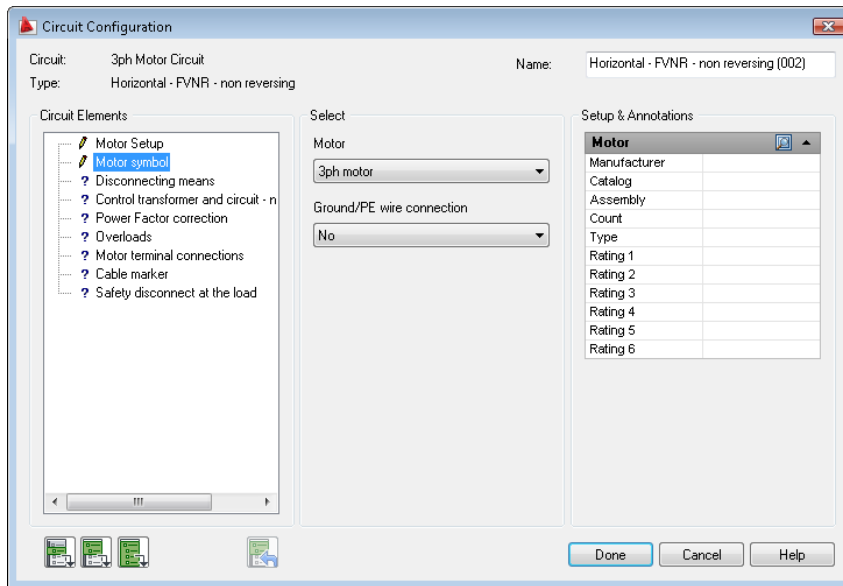

- 2 In the Circuit Elements section, select **Disconnecting Means**.  
In the Select section, select Main Disconnect: **Fuses**,  
Include N.O. auxiliary contact: **No**.

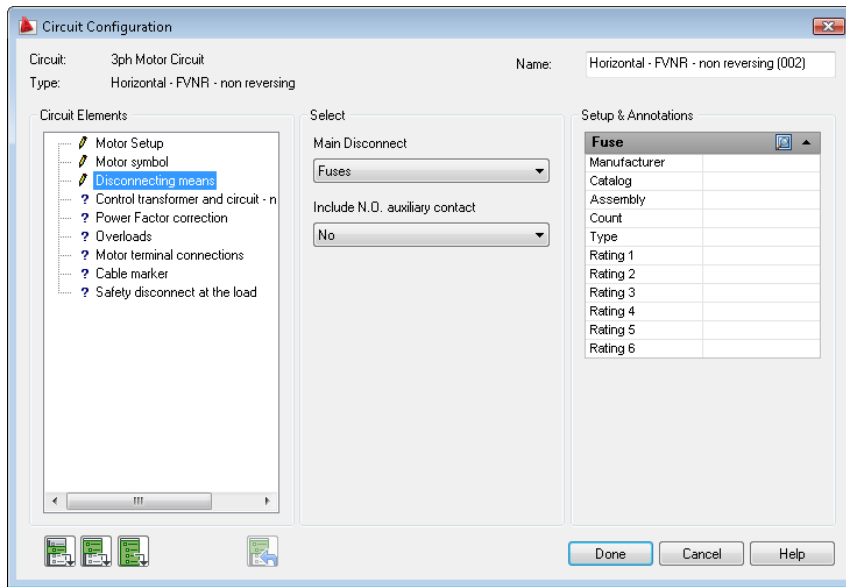

**Setup & Annotation section:** The options within this section change according to your selections in the Circuit Elements and Select sections.

Type in values or select the Browse button to access a lookup table. 

Select an entry from the lookup table to obtain values for the individual settings. If the circuit option is a component, the catalog lookup opens.

- 3 In the Circuit Elements section, select **Control transformer and circuit - non-reversing**.

In the Select section, select Include control circuit: **None**.

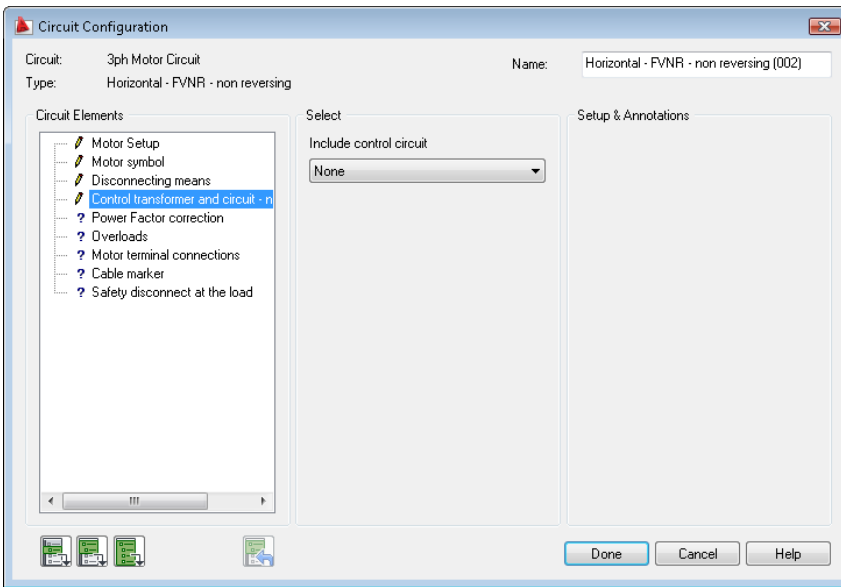

- 4 In the Circuit Elements section, select **Power Factor correction**.  
In the Select section, select Include power factor correction capacitor:  
**None**.

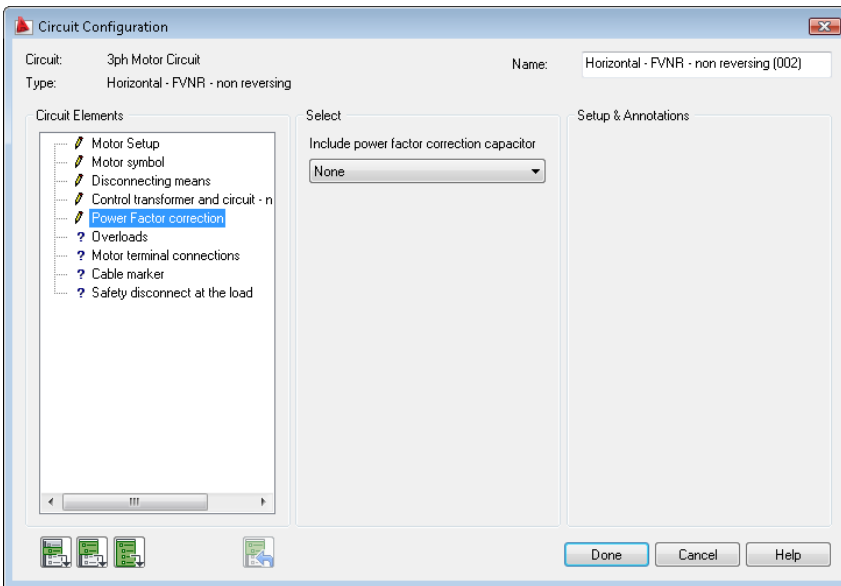



- 5 In the Circuit Elements section, select **Overloads**.  
In the Select section, select Overload elements: **Thermal**,  
Include N.O. auxiliary contact: **No**.

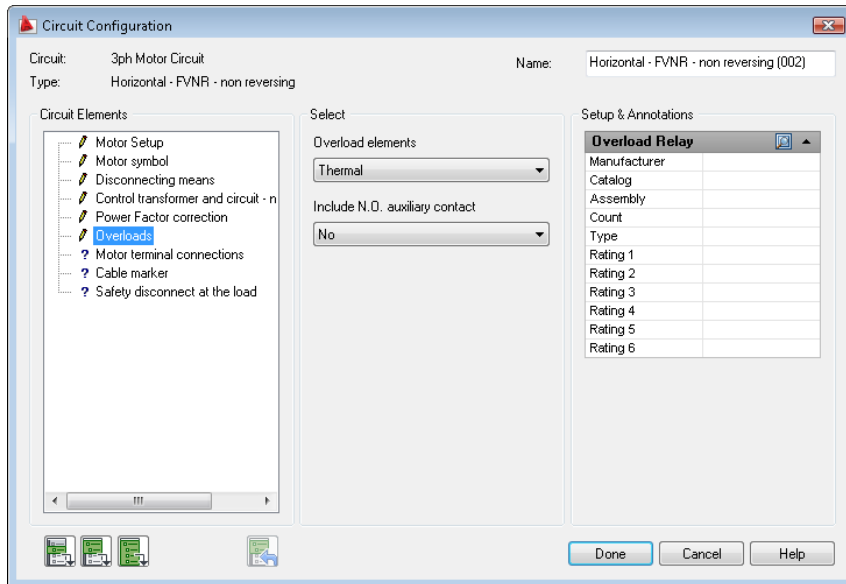

- 6 In the Circuit Elements section, select **Motor terminal connections**.  
In the Select section, select Motor connection terminals: **Round**.

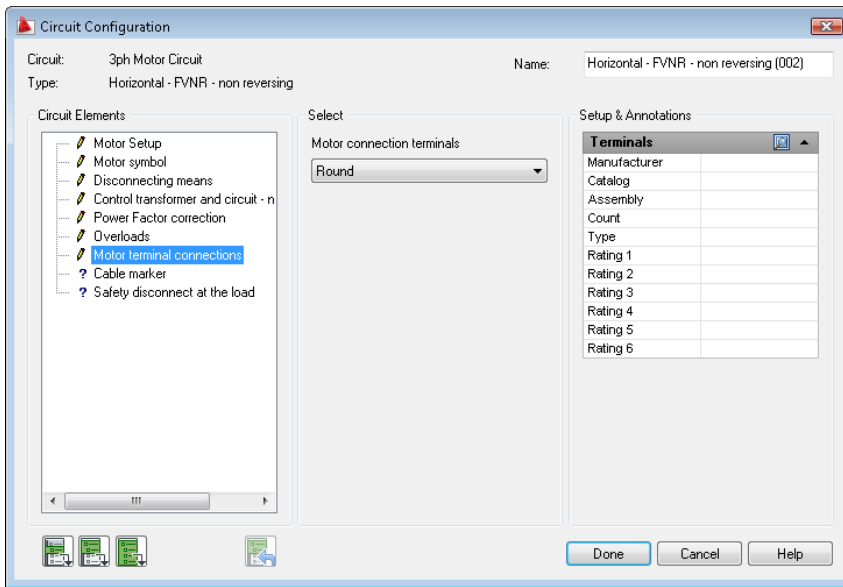

7 In the Circuit Elements section, select **Cable marker**.  
In the Select section, select Cable: **None**.

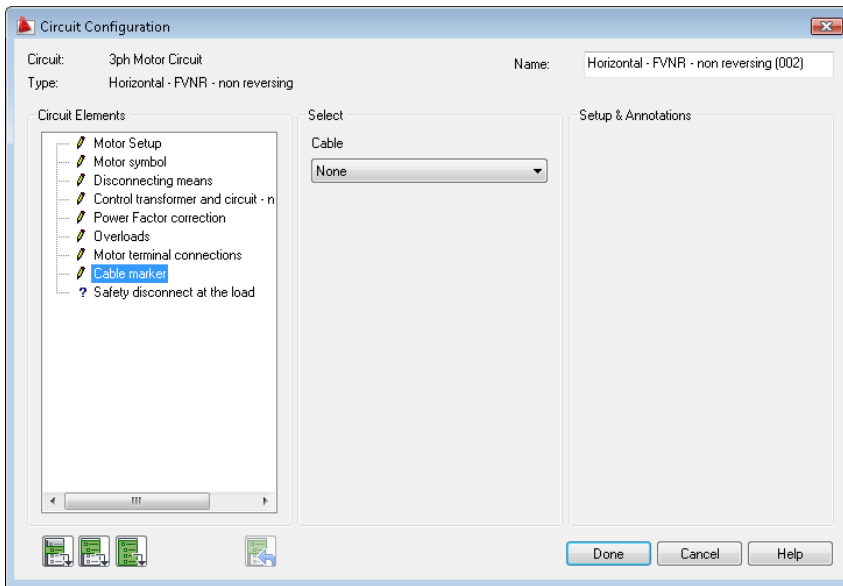

- In the Circuit Elements section, select **Safety disconnect at the load**. In the Select section, select Safety disconnect: **Disconnect switch**, Include N.O. auxiliary contact: **No**.

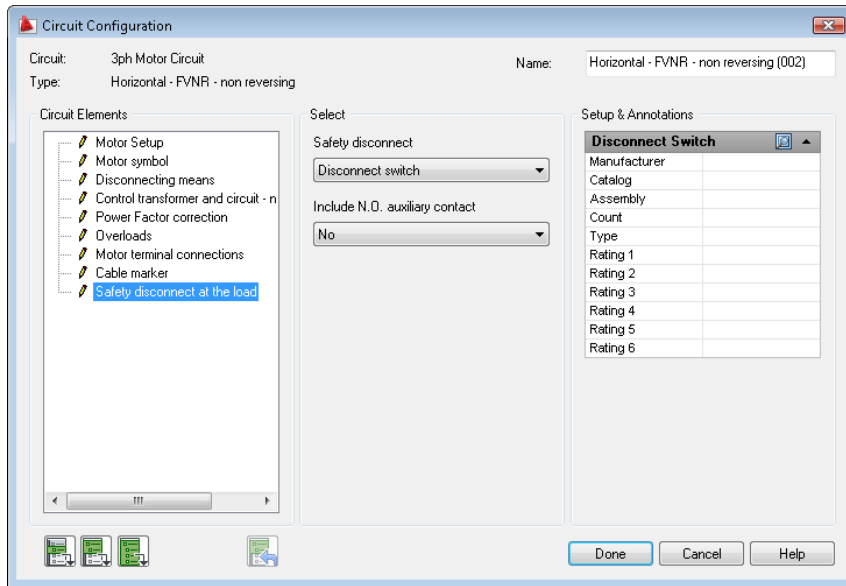

- Select the Insert all circuit elements tool. Circuit Builder inserts each of the selected circuit elements.

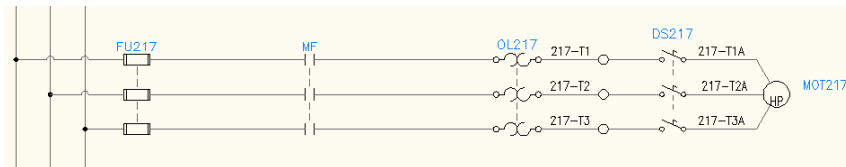

- Select Done.

**NOTE** See the Circuit Builder topics later in this section for more examples.

## Save and insert a circuit

AutoCAD®Electrical makes saving and inserting pre-drawn circuits easy and convenient. You can save and insert from a user circuits page on the Insert Component icon menu. You can also use the normal AutoCAD® WBlock command to save selected circuitry to disk. Use the Insert Circuit command to insert WBlocked circuits into the active drawing.

### Save your circuit for use in the future

- 1 Zoom around the circuit so that it fills your screen.
- 2 Click Schematic tab ► Edit Components panel ► Circuit



drop-down ► Save Circuit To Icon Menu.

- 3 On the Save Circuit to Icon Menu dialog box, click Add ► New circuit.
- 4 On the Create New Circuit dialog box, specify:

Name: Motor Circ - Fusible DS

Image file: Click Active and check Create PNG from current screen image

File name: UserCirc1

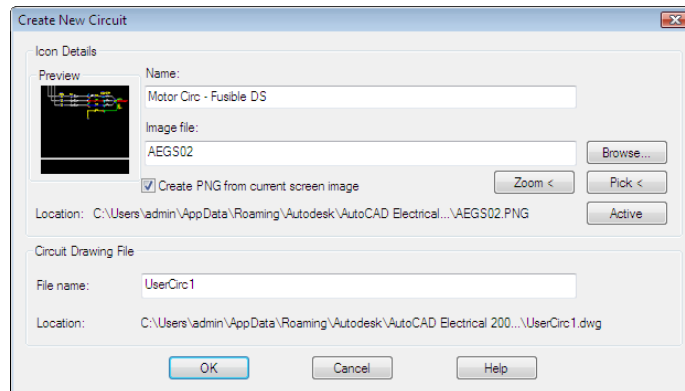

- 5 Click OK.
- 6 Respond to the prompts as follows:  
Base point:

Select the left-most wire connection point where the circuit ties into the left-hand vertical bus wire

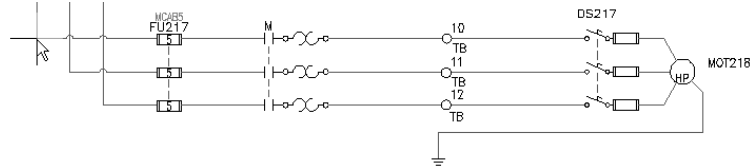

Select objects:

Window around the circuit from left to right to capture all the components and wiring, but exclude the vertical bus, press ENTER

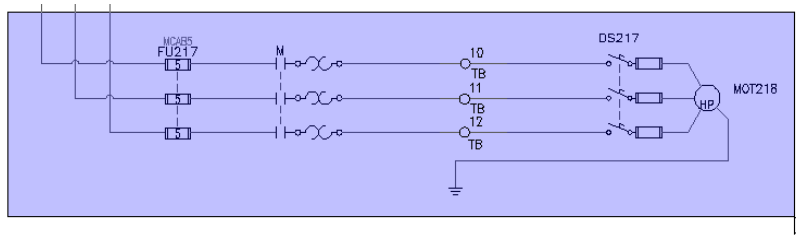

- 7 On the Save Circuit to Icon Menu dialog box, click OK.

The circuit is saved to your AutoCAD Electrical user folder. It can be quickly accessed from the Insert Component icon menu or from the Insert Saved Circuit tool.

The new motor has a 3-pole motor contactor child reference but there is not a parent motor starter relay coil to operate it. The motor start coil circuit must be added on a control schematic in the project drawing set and linked back to the new motor circuit.

### Insert motor start coil circuit to control schematic

- 1 Open *AEGS04.dwg*.
- 2 Zoom on the upper-right hand ladder column so the full circuit on line reference 422-423 displays.
- 3 Click Schematic tab ► Edit Components panel ► Circuit



drop-down ► Save Circuit To Icon Menu.

4 On the Save Circuit to Icon Menu dialog box, click Add ► New circuit.

5 On the Create New Circuit dialog box, specify:

Name: Motor starter circ

Image file: Active and Create PNG from current screen image

File name: UserCirc2

Click OK.

6 Respond to the prompts as follows:

Base point: *Select the left-most wire connection point at line reference 422*

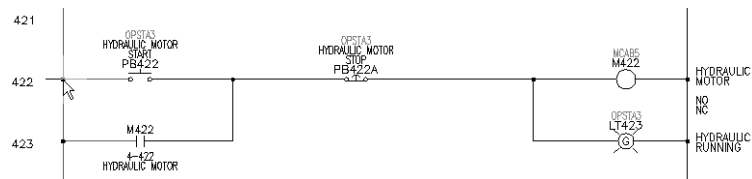

Select objects:

*Window around the circuit from left to right to capture all the components and wiring, but exclude the vertical bus, press ENTER*

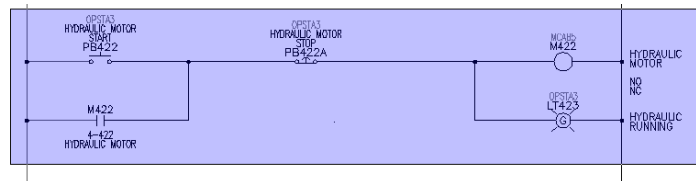

7 On the Save Circuit to Icon Menu dialog box, click OK.

## Insert a circuit you saved for reuse

1 Pan to display the blank area between line references 426 - 432.

2 Click Schematic tab ► Insert Components panel ► Circuit



drop-down ► Insert Saved Circuit.

3 In the JIC: Saved User Circuits dialog box, select the Motor starter circ button.

4 In the Circuit Scale dialog box, click OK.

**5** Respond to the prompts as follows:

Specify insertion point:

*Place the circuit insertion point on the vertical bus wire at line reference 427, left-click to insert the circuit.*

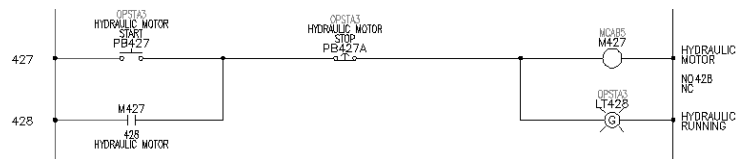

The circuit inserts and updates. Tags automatically update to reflect the new line reference number, and parent/child relationships defined inside of the circuit update accordingly.

**6** Right-click the M427 coil symbol and select Edit Component.

**7** In the Insert/Edit Component dialog box, specify:

Description Line 2: MOTOR NO. 2

Click OK.

**8** In the Update Related Components dialog box, click Yes-Update.

### Linking the parent coil to the child contactor

**1** Open *AEGS02.dwg* and zoom on the untagged 3-pole motor contact/overloads on line reference 217.

**2** Right-click the “M” contact and select Edit Component.

The Insert/Edit Child Component displays. Enter the exact parent coil tag into the Component Tag box to establish the link between the parent and the child contacts. Currently the Component Tag is M.

**3** In the Insert/Edit Child Component dialog box, Component Tag section, click Project.

**4** In the Complete Project list for Family=“M” dialog box, select M427 HYDRAULIC MOTOR NO. 2 and click OK.

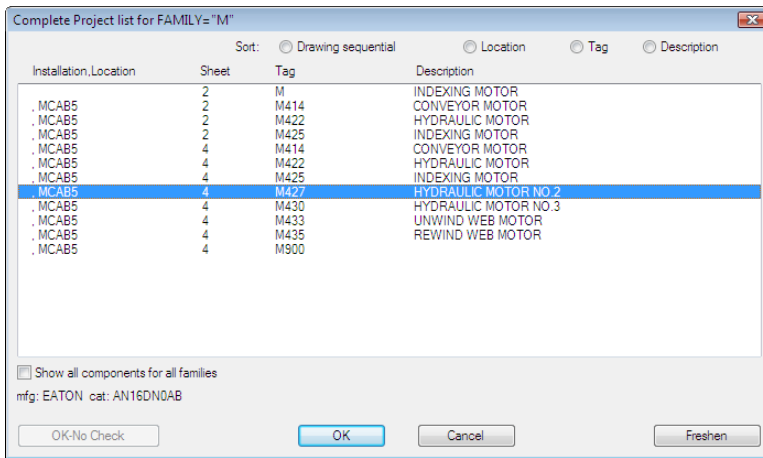

The tag M427 is now displayed in the Component Tag edit box. Notice that the description, cross-reference, and location code boxes have also updated.

- 5 In the Insert/Edit Child Component dialog box, click OK.
- 6 In the Update linked components dialog box, click OK.

The components are now linked. If you go back to drawing *AEGS04.dwg* and look at the motor starter coil, it shows references to these three child contacts (plus one seal contact around PB427).

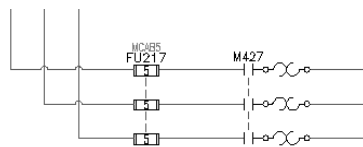

## Using the icon menu to add a motor

- 1 Reopen drawing *AEGS04.dwg* and zoom to the blank area at line references 430-431.
- 2 Repeat the steps for inserting the saved Motor starter circ circuit.
- 3 In the Circuit Scale dialog box, click OK.
- 4 Insert the circuit at line reference 430.
- 5 Right-click the M430 coil symbol, and select Edit Component.



6 In the Insert/Edit Component dialog box, specify:

Description Line 2: MOTOR NO. 3

Click OK.

7 In the Update related components dialog box, click Yes-Update.

8 Open drawing *AEGS02.dwg* and zoom to the blank area at line references 204-206.

9 Repeat the steps for inserting a saved circuit, but this time insert the Motor Circ - Fusible DS circuit.

10 In the Circuit Scale dialog box, click OK.

11 Respond to the prompts as follows:

Specify insertion point:

*Position the motor circuit so that the insertion point lands on the left-hand vertical bus at line reference 204, left-click to insert the circuit.*

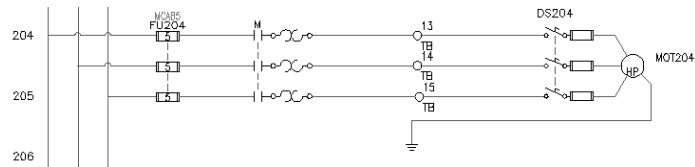

Notice that the fuse, disconnect, and motor automatically retag based on their reference locations.

12 Right-click the M child motor contact symbol, and select Edit Component.

13 In the Insert/Edit Child Component dialog box, Component Tag section, click Project.

14 In the Complete Project list for Family="M" dialog box, select M430 HYDRAULIC MOTOR NO. 3 and click OK.

The tag M430 is now displayed in the Component Tag edit box. Notice that the description, cross-reference, and location code boxes have also updated.

15 In the Insert/Edit Child Component dialog box, click OK.

16 In the Update linked components dialog box, click OK.

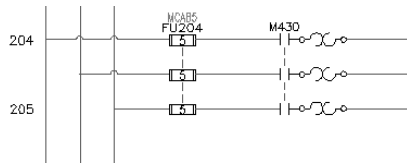

## Insert a saved circuit using WBlock

Another method for saving and inserting circuits is to use the AutoCAD WBlock command to save the circuit to disk. A separate Insert Circuit command is used to browse to a selected saved circuit and insert it into the active drawing. This method allows unlimited circuits to be constructed and saved to disk. They can be arranged into a set of shared subfolders for easy browsing and retrieval using the Insert Circuit command.

### Saving a circuit using WBlock

- 1 Pan to display the 3-phase motor circuit at line references 207 - 209.
- 2 Enter *wblock* at the command line and press ENTER.
- 3 In the Write Block dialog box, click Pick point.
- 4 Respond to the prompts as follows:

Specify insertion base point:

*Select the intersection of the left vertical bus with the upper horizontal wire at line reference 207*

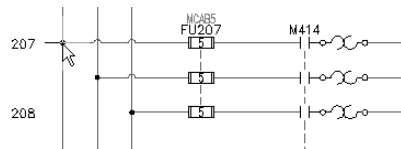

- 5 In the Write Block dialog box, click Select objects.
  - 6 Respond to the prompts as follows:
- Select objects: *Window from left to right around the full circuit, right-click*

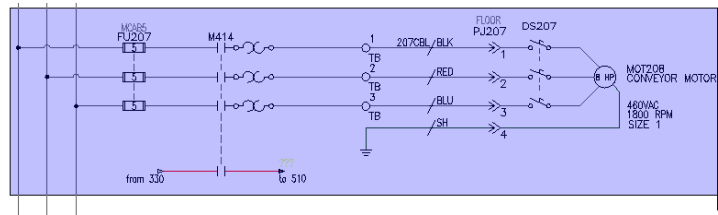

- 7 In the Write Block dialog box, enter a name for the saved circuit. Take note of the location where the drawing file is being saved.
- 8 Click OK.

### Inserting a WBlocked circuit

- 1 Click Schematic tab ► Insert Components panel ► Circuit



drop-down ► Insert WBlocked Circuit.

- 2 In the Insert Wblocked Circuit dialog box, browse to the folder containing the circuit you saved.
- 3 Select the WBlocked motor circuit, and click Open.
- 4 In the Circuit Scale dialog box, select:
  - Move all lines to wire layers
  - Keep all source arrows
  - Update circuit's text layers as required
  - Click OK.
- 5 Respond to the prompts as follows:
  - Specify insertion point: *Select any blank spot on your drawing*
  - The parent component tags that are not set to Fixed automatically retag based on the insertion point. It is like the behavior when inserting a circuit using the icon menu method.
- 6 Delete the circuit.

## Insert a one-line motor control circuit

In this exercise, you insert and configure a one-line motor control circuit using Circuit Builder.

- In the Project Manager, Project Drawing List, double-click *One-Line.dwg*. *One-Line.dwg* contains a one-line bus. This wire is drawn on a wire layer defined as No Wire Numbering. Such a wire layer behaves normally for inserting, breaking, and scooting components. These wires also show up in the from/to report. Wire numbers are not placed on these wires during the Insert Wire Numbers process.

### Insert the one-line circuit

- 1 Click Schematic tab ➤ Insert Components panel ➤ Circuit Builder



drop-down ➤ Circuit Builder.

The Circuit Selection dialog box displays.

- 2 Expand One-line Motor Circuit.
- 3 Select **Vertical - FVNR - non reversing**.
- 4 Click Configure.
- 5 Specify an insertion point on the one-line bus.

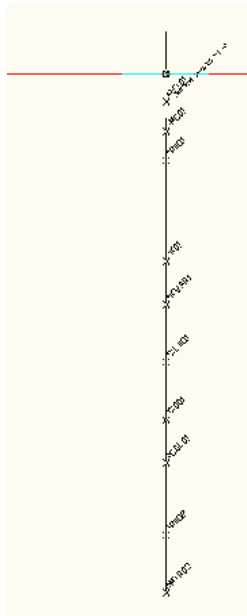

The Circuit Configuration dialog box displays.

**6** In the Circuit Elements section, select **Motor Setup**.

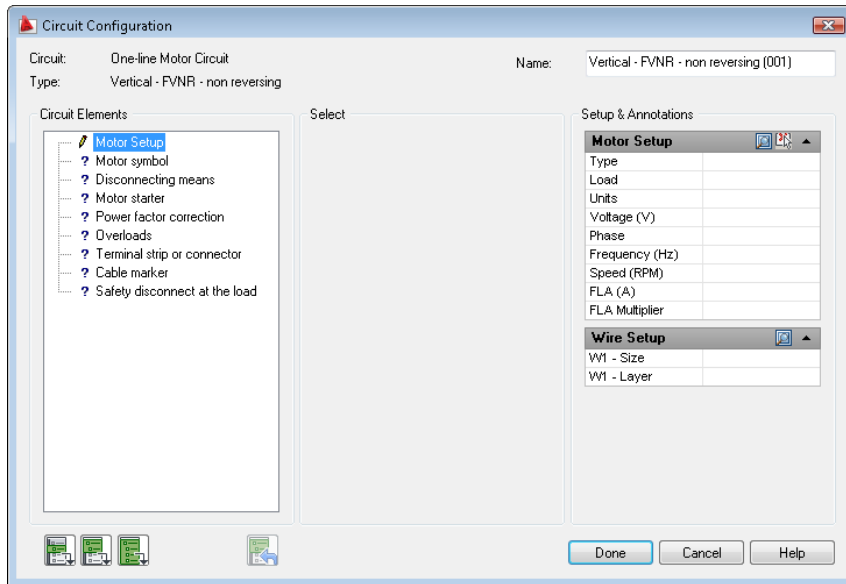

Insert a one-line motor control circuit | **1793**

- 7  In the Setup & Annotations: Motor Setup section, select the Browse button.  
The Motor Table Not Found dialog box displays. The sample project is set up to use the NEC standard. However, a MOTOR\_NEC table is not supplied, only a default MOTOR table.
- 8 Select Use default table.  
The Select Motor dialog box displays.
- 9 Select Type: **Induction**, Voltage (V): **480**, and Frequency (HZ): **60**.
- 10 Select the row that shows Load: **15**, Units: **HP**, Phase: **3**, Speed (RPM): **3600**, FLA (A) **18.6**.

---

**NOTE** The values used to populate this dialog box are defined in the MOTOR\* tables in the electrical standards database file, *ace\_electrical\_standards.mdb*.

---

- 11 Click OK.  
The values are entered in the Motor Setup section. A default wire size, based on the load for the motor, is selected and shown in the Wire Setup section.

- 12  In the Setup & Annotations: Wire Setup section, select the Browse button.  
The Wire Size Lookup dialog box displays. The minimum wire size is preselected. The size is based on the load for the selected motor.

---

**NOTE** When Show all is on, wires where the %Ampacity value is greater than 100% and less than 300%, are shown in red.

---

The values in the Load section are populated with the values from the Motor Setup. The options available within this dialog box are defined in the electrical standards database file, *ace\_electrical\_standards.mdb*.

- 13 In the Wire section, select Size standard: **AWG**, Type/method: **CU**, Insulation: **THWN / 75C**.
- 14 In the De-rating factors section, select the **Ambient temperature correction** option.

This option directs Circuit Builder to use a de-rating factor for an elevated ambient temperature. These values are defined in the electrical standards database file.

- 15** Select **36~40C** from the drop-down list.

The de-rating factor is extracted from the electrical standards database file and entered in the dialog box. The wire size grid is adjusted based on the new total de-rating factor. Based on this de-rating factor the minimum wire size can change.

- 16** Select the **Run distance** option.

This option directs Circuit Builder to consider the length of the wire run in the voltage drop calculation. Additional columns display in the wire selection grid showing Voltage drop, wire KW loss, and wire loss cost estimate.

- 17** Select **200** from the drop-down list.

Circuit Builder displays parallel energy loss calculations to allow you to make better green design decisions. For example, you can oversize the conductors for a motor to reduce conductor heating losses. It results in a higher initial cost, material, and installation labor, which is recovered many times over in reduced energy losses in the wiring during the life of the motor.

- 18** Select a wire size in the grid based on the values shown.

- 19** Select a Grounding conductor size. The minimum size is preselected based on the load of the motor.

- 20** Click OK.

- 21** Select Circuit Elements: **Motor Symbol**.



- 22** In the Setup & Annotations: Motor section, select the Browse button.

The Parts catalog dialog box displays.

- 23** Select a catalog value and click OK.

---

**NOTE** Circuit Builder does not preselect the catalog based on the parameters entered previously.

---

- 24** Continue selecting Circuit Elements:

Disconnecting means: **Disconnect switch and fuses**

Motor starter: **Yes**

Power factor correction: **No**

Overloads: **None**

Terminal strip or connector: **None**

Cable marker: **Yes**

Safety disconnect at the load: **None**



25 Click to insert all circuit elements.

26 Click Done.

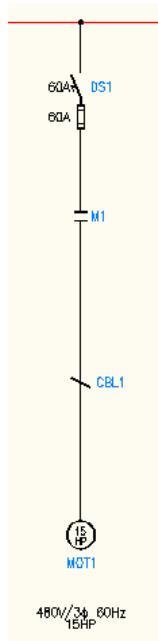

27 Click Schematic tab > Edit Components panel > Edit Components



drop-down > Edit.



- 28 Select the motor symbol.
- 29 On the Insert/Edit Component dialog box, enter **FIELD** for the Location code and **MY MOTOR** for Description Line 1.
- 30 Save the drawing.

## Insert a one-line dual power feed circuit

In this part of the exercise, you insert a dual power feed circuit. A dual circuit has two distinct circuits running off the same bus-tap. Each circuit can be independently configured.

- 1 Click Schematic tab ► Insert Components panel ► Circuit Builder



drop-down ► Circuit Builder.

- 2 The Circuit Selection dialog box displays.
- 3 Select **One-line Power Feed: Vertical - Dual feed**.
- 4 Click Configure.
- 5 Specify an insertion point on the one-line bus.

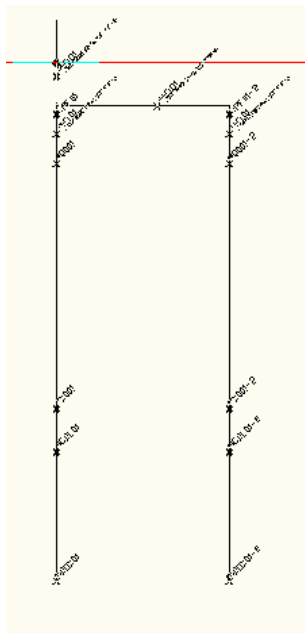

The Circuit Configuration dialog box displays. Notice that some circuit elements have a “(2)” prefix. These elements make up the second circuit in the dual circuit.

- 6 In the Circuit Elements section, select **Load Setup**.



- 7 In the Setup & Annotations: Load Setup section, select the Browse button.

The Select Load dialog box displays.

- 8 Select Type: **Transformer**, Voltage (V): **480**, and Phase: **3**.

- 9 Select an entry from the grid and click OK.

- 10 Continue selecting Circuit Elements for the first circuit:

Load: **Generic box**

Disconnecting means: **None**

Terminal strip or connector: **Square**

Cable marker: **None**

- 11 In the Circuit Elements section, select **(2) Load Setup**.

-  In the Setup & Annotations: Load Setup section, select the Browse button.  
The Select Load dialog box displays.
- 13 Select Type: **Transformer**, Voltage (V): **480**, and Phase: **3**.
- 14 Select an entry from the grid and click OK.
- 15 Continue selecting Circuit Elements for the second circuit:  
(2) Load: **Source arrow**  
(2) Disconnecting means: **Disconnect switch and fuses**  
(2) Terminal strip or connector: **None**  
(2) Cable marker: **None**

-  Click to insert all circuit elements.
- 17 Click Done.

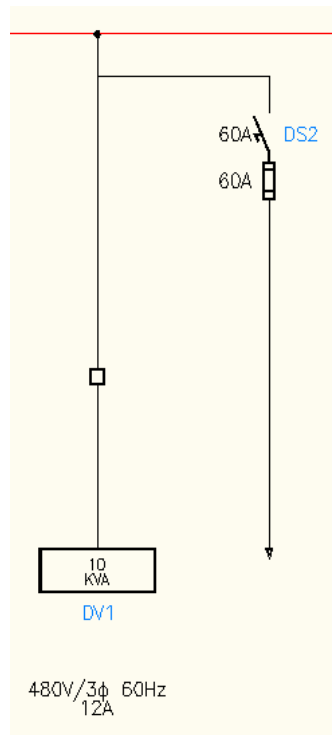

18 Save the drawing.

## Reference an existing circuit

When a new circuit is inserted, you can reference an existing circuit picked from a list of circuits pulled from the active project. The components, values, descriptions, and tag assignments from the selected circuit, become defaults for the new circuit. Tags are recalculated if the option “Retag new components” is selected.

In this exercise, you insert a 3-phase motor control circuit referencing the one-line motor control circuit inserted earlier.

- 1 Start a new blank drawing and save it as *Three-Line.dwg*.
- 2 In Project Manager, right-click on the project name and select Add Active Drawing.

- 3 Click Yes to apply the project default values to the drawing settings.
- 4 Click Schematic tab ► Insert Wires/Wire Numbers panel ► Insert Ladder

drop-down ► Insert Ladder. 

- 5 Insert a 3-phase ladder.
- 6 Click Schematic tab ► Insert Components panel ► Circuit Builder

drop-down ► Circuit Builder. 

- 7 The Circuit Selection dialog box displays.
- 8 Select **3ph Motor Circuit: Horizontal - FVNR - non reversing**.
- 9 Select Reference Existing Circuit.
- 10 Select the List button.  
The Existing Circuits dialog box displays.
- 11 Select the one-line motor control circuit inserted on *One-Line.dwg*, **MOT1**.
- 12 Click OK.

The CODE and UI\_VAL values from the circuit codes sheet of the circuit builder spreadsheet control the default circuit element options. For example, the one-line circuit used the Disconnect switch and fuses option with a UI\_VAL of "4". When the 3-phase circuit references this one-line circuit, the disconnecting means option with a UI\_VAL of "4" becomes the default. If a matching UI\_VAL is not found for a particular marker block CODE value, the default as defined by the "X" in the UI\_DEF column is used.

When the new circuit is built, component values from the referenced circuit are applied to components in the new circuit only if the [marker block](#) on page 659 code matches.

- 13 Turn off the Retag new components check box.

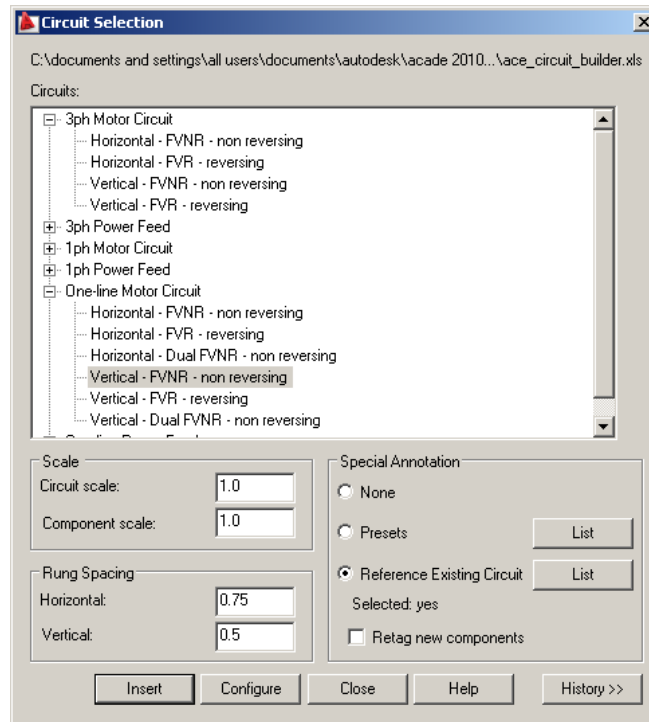

It directs Circuit Builder to use the tags from the one-line circuit for the components with matching marker block code values.

- 14 Select Configure.
- 15 Select an insertion point on the bus for the new circuit.
- 16 Verify that the same circuit elements as the referenced one-line motor circuit are selected. The default options are based on the referenced circuit.

Circuit Elements	Select
<b>Motor symbol</b>	Motor: <b>3ph motor</b> Ground/PE wire connection: <b>No</b>
<b>Disconnecting means</b>	Main Disconnect: <b>Disconnect switch and Fuses</b> Include N.O. Auxiliary contact: <b>No</b>
<b>Control transformer and circuit - non-reversing</b>	Include control circuit: <b>None</b>

### Circuit Elements

### Select

Power Factor correction

Include power factor correction capacitor: **None**

Overloads

Overload elements: **None**

Include N.O. auxiliary contact: **No**

Motor terminal connections

Motor connection terminals: **None**

Cable marker

Cable: **Yes**

Safety disconnect at the load

Safety disconnect: **None**

Include N.O. auxiliary contact: **No**

- 17  Click to insert all circuit elements.
- 18 Click Done.

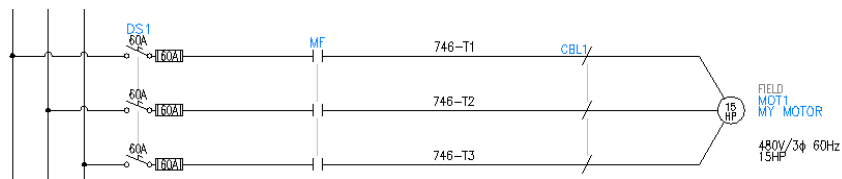

The circuit is inserted and the component values from the one-line circuit are applied. The motor symbol receives the same catalog value and horsepower rating. The main disconnect switch receives the same rating values for the switch and the fuses. The motor symbol receives the values modified on the one-line circuit after it was inserted.

# Surf

## Surf - Introduction

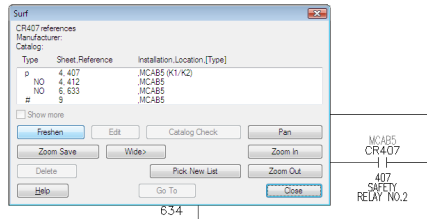

Move between related components with Surfer.

Time required 10 minutes

Prerequisites: Copy all files located in

**Windows XP** *Documents and Settings\{username}\My Documents\Acade {version}\Aedata\Tutorial\Aegs\Surf*  
to  
*Documents and Settings\{username}\My Documents\Acade {version}\Aedata\Proj\Aegs*

**Windows Vista,** *Users\{username}\Documents\Acade {version}\Aedata\Tutorial\Aegs\Surf*  
**Windows 7** to  
*Users\{username}\Documents\Acade {version}\Aedata\Proj\Aegs*

You learn to:

- Use the Surfer tool

## Moving between symbols

Use the AutoCAD Electrical Surf utility to move from component reference to reference across the project drawing set quickly.

- 1 If AEGS is not the active project, in the Project Manager, right-click AEGS and select Activate.
- 2 In the Project Manager, double-click AEGS to expand the drawing list.
- 3 In the Project Manager, Project Drawing List, double-click *AEGS04.dwg*.



- 4 Zoom on the upper left-hand portion of the first ladder column.
- 5 Click Projects tab ► Other Tools panel ► Surfer drop-down ► Surfer.



- 6 Click anywhere on relay coil CR407.  
All instances of CR407 appear in the Surf dialog box.

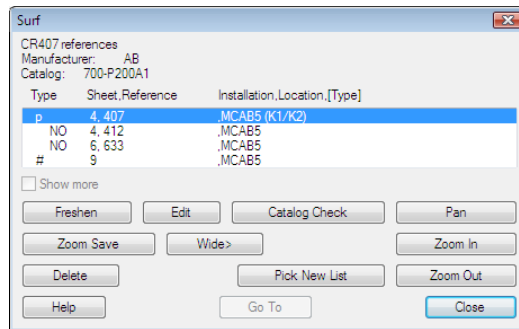

- 7 Select the reference on sheet 6.
- 8 Click Go To.

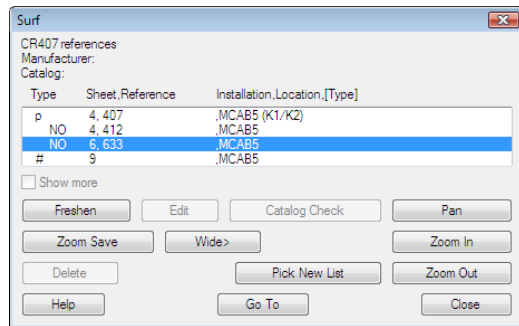

The instance of CR407 on sheet 6 is surfed to and displayed in the drawing next to the Surf dialog box.

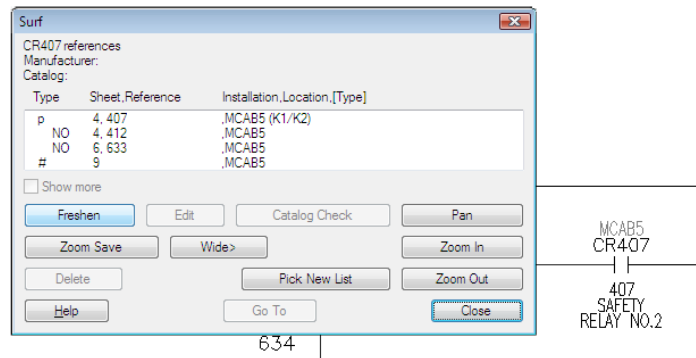

- 9 Select the reference on sheet 9.
- 10 Click Go To.  
You can edit or delete the component using options in the Surf dialog box.
- 11 Double-click the first entry in the Surf dialog box to return to the original *AEGSO4.dwg* drawing.
- 12 Click Close.

---

**NOTE** If AutoCAD Electrical senses that a change has been made to the drawing while surfing, drawing files are saved. .

---

# Block swap

## Block swap - Introduction



Swap components while maintaining wire connections with Swap/Update Block.

Time required 10 minutes

Prerequisites: Copy all files located in

**Windows XP** *Documents and Settings\{username}\My Documents\Acade {version}\Aedata\Tutorial\Aegs\Block swap*  
to  
*Documents and Settings\{username}\My Documents\Acade {version}\Aedata\Proj\Aegs*

**Windows Vista, Windows 7** *Users\{username}\Documents\Acade {version}\Aedata\Tutorial\Aegs\Block swap*  
to  
*Users\{username}\Documents\Acade {version}\Aedata\Proj\Aegs*

You learn to:

- Use the Block Swap tool

## Swapping components

Use the Swap Block tool to swap one component for another in a single drawing or project-wide. For example, swapping a proximity switch with a limit switch.

## Swap switches while keeping wire connections

- 1 If AEGS is not the active project, in the Project Manager, right-click AEGS and select Activate.
- 2 In the Project Manager, double-click AEGS to expand the drawing list.
- 3 In the Project Manager, Project Drawing List, double-click *AEGS04.dwg*.
- 4 Zoom in on the limit switch on line reference 406.

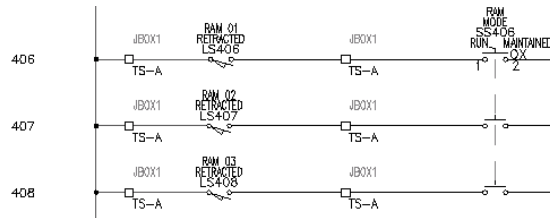

- 5 Click Schematic tab ► Edit Components panel ► Swap/Update Block.



- 6 In the Swap Block/ Update Block/ Library Swap dialog box, specify:
  - Option A: Swap a Block - drawing wide
  - Pick new block from icon menu
  - Retain old block scale
  - Auto re tag if parent swap causes FAMILY change
  - Attribute Mapping: Use Same Attribute Names (default)
  - Click OK.
- 7 In the Insert Component: JIC Schematic Symbols dialog box, click

Miscellaneous Switches. 

- 8 In the JIC: Other Switch Types dialog box, click Proximity Switch NO.



- 9 Respond to the prompts as follows:
  - Select component type to swap out: *Select the limit switch, LS406*

The limit switch symbol disappears and the proximity switch symbol inserts. All existing text annotation transfers to the new symbols and the wires reconnect.

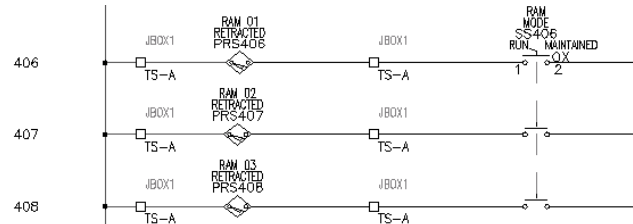

## PLC

### PLC - Introduction

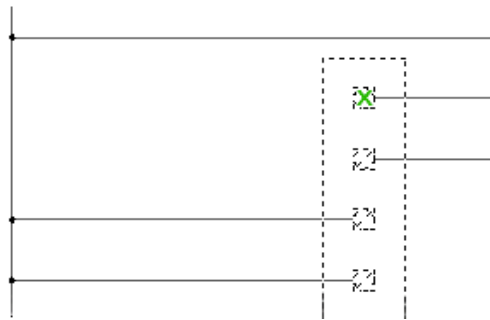

Insert PLC modules and connected devices.

Time required 30 minutes

Prerequisites: Copy all files located in

**Windows XP** *Documents and Settings\{username}\My Documents\Acade {version}\Aedata\Tutorial\Aegs\PLC*  
to  
*Documents and Settings\{username}\My Documents\Acade {version}\Aedata\Proj\Aegs*

**Windows Vista, Windows 7** *Users\{username}\Documents\Acade {version}\Aedata\Tutorial\Aegs\PLC*  
to

Users\{username}\Documents\Acade {version}\Aedata\Proj\Aegs

You learn to:

- Understand PLC parametric build
- Insert a PLC module
- Remove ladder rungs
- Use multiple insert component
- Annotate PLC I/O descriptions

## Inserting PLC modules

AutoCAD Electrical generates any of hundreds of different PLC I/O modules on demand. The modules generate in various different graphical styles, all without a single, complete I/O module library symbol resident on the system. Modules adapt to the underlying ladder rung spacing, whatever that value is. They can be stretched or broken into two or more pieces at insertion time.

To insert a PLC module, you select the module and pick a location. AutoCAD Electrical builds and inserts the module, using a small set of library symbols.

### Insert a PLC module

- 1 If AEGS is not the active project, in the Project Manager, right-click AEGS and select Activate.
- 2 In the Project Manager, double-click AEGS to expand the drawing list.
- 3 In the Project Manager, Project Drawing List, double-click *AEGS05.dwg*.
- 4 Click Schematic tab ► Insert Components panel ► Insert PLC



drop-down ► Insert PLC (Parametric).

- 5 In the PLC Parametric Selection dialog box, select:  
Manufacturer: Allen-Bradley  
Series: 1746  
Type: Discrete Input  
Part Number: 1746-IA16

Graphics style: 2, Vertical Module

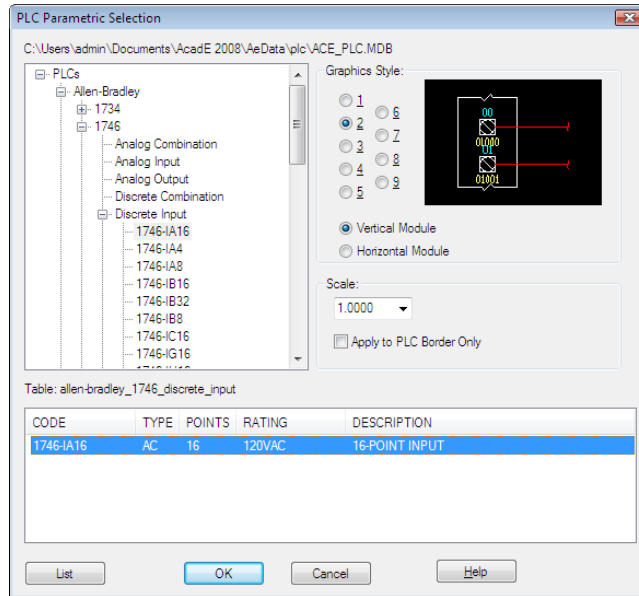

6 Click OK.

7 Respond to the prompts as follows:

Specify PLC module insertion point or [Z=zoom, P=pan]:

*Pick a point on wire line reference 520 closer to the right side, ensure the X is near the horizontal wire, click*

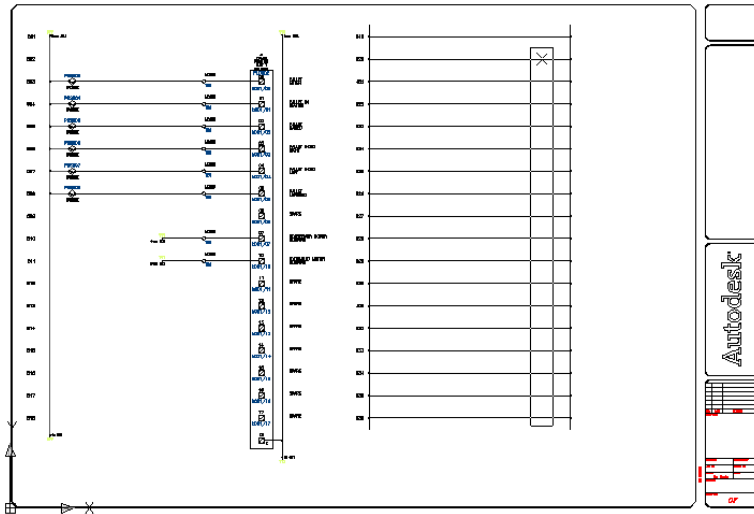

- 8 In the Module Layout dialog box, verify the default settings:

Spacing: 1.0000

I/O Points: Insert all

Click OK.

AutoCAD Electrical reads the vertical rung spacing of your ladder and calculates how long the module is going to be. It multiplies the rung spacing by the number of wire connections specified by the module you selected.

Temporary graphics display a representation of the module (with the spacing defined) to help position the module on the ladder.

- 9 In the I/O Point dialog box, specify:

Rack Number: 1

Slot Number: 1

---

**NOTE** Specify the values by either entering text into the edit boxes or by clicking the arrows.

---

- 10 Click OK.
- 11 In the I/O Address dialog box, specify:  
Beginning address: I:11/00



---

**NOTE** You can also select the beginning address from the Quick picks list.

---

- 12 Click OK.
- 13 In the I/O Addressing dialog box, click Decimal.

The PLC module is inserted into your drawing with incremental address numbers already annotated as the module goes in, it breaks and reconnects to underlying wires.

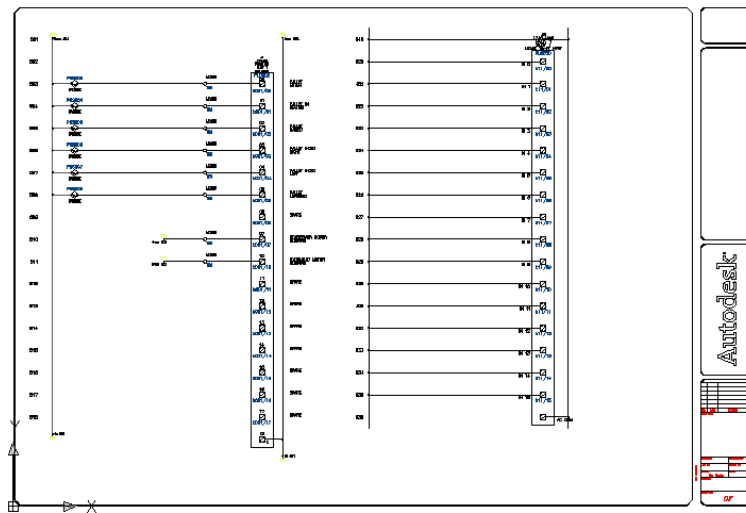

You can break an I/O module into as many pieces as you want at insertion time. It is great for high-density modules that do not fit into a single ladder column. Use the Allow spacers/breakers option in the Module Layout dialog box at insertion time to do it.

You can also add extra space between adjacent I/O points using the Stretch Block tool. This feature leaves extra room when you know ahead of time that a certain I/O point will have additional components wired tied to a single I/O point after a PLC module is inserted.

---

**NOTE** It can be used on any block, not just a PLC module.

---

## Remove ladder rungs

- 1 Click Schematic tab ► Edit Wires/Wire Numbers panel ► Trim Wire.



- 2 Respond to the prompts as follows:

Fence/Crossing/Zext/<Select wire to TRIM>:

Select the ladder rung at line reference 519, right-click

The ladder rung is removed from your drawing.

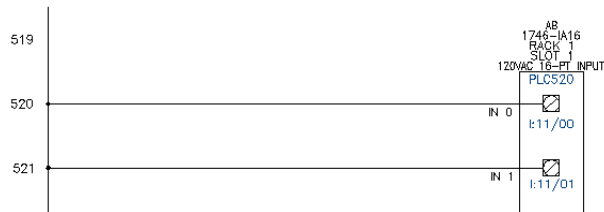

## Using multiple insert component

You can insert components into wires that are tied to the PLC module. Use the Multiple Insert Component tool to insert a string of normally open limit switches.

### Insert a limit switch

- 1 Click Schematic tab ► Insert Components panel ► Multiple Insert



drop-down ► Multiple Insert (Icon Menu).

- 2 In the Insert Component: JIC Schematic Symbols dialog box, click Limit



Switches.

- 3 In the JIC: Limit Switches dialog box, select Limit Switch, NO.



- 4 Respond to the prompts as follows:

Component Fence, From Point:

*Select above the wire at line reference 520 (1)*

Component Fence, From Point: to:

*Drag below the wire at line reference 522, click the point (2), right-click*

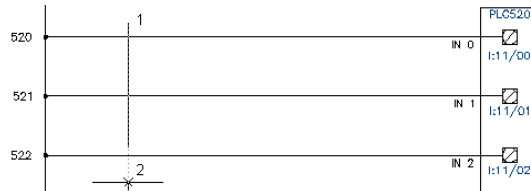

**5** In the Keep dialog box, select:

Keep this one

Show edit dialog box after each

Click OK

**6** In the Insert/Edit Component dialog box, specify:

Component Tag: LS520

Description: Line 1: PALLET ENTERING

Description: Line 2: STATION

Location code: MACHINE

Click OK.

---

**NOTE** In the Insert/Edit Component dialog box, Component Tag section, you can use the Use PLC Address button to add the I/O Address as the component tag.

---

**7** In the Keep dialog box, select:

Keep this one

Show edit dialog box after each

Click OK

**8** In the Insert/Edit Component dialog box, specify:

Component Tag: LS521

Description: Line 1: PALLET INSIDE

Description: Line 2: STATION

Location code: MACHINE

Click OK.

- 9 In the Keep dialog box, select:

Keep this one

Show edit dialog box after each

Click OK

- 10 In the Insert/Edit Component dialog box, specify:

Component Tag: LS522

Description: Line 1: PALLET LEAVING

Description: Line 2: STATION

Location code: MACHINE

Click OK.

The normally open limit switches are inserted into the drawing.

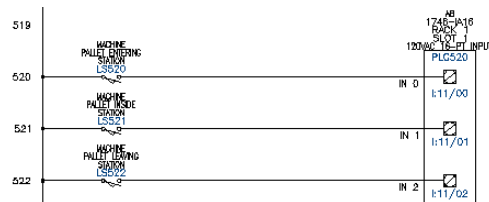

## Annotating PLC I/O descriptions

You can add description text to a PLC module using the Edit Component tool. You can change the descriptions at any time. However, edit each split PLC piece separately.

### Add description text

- 1 Click Schematic tab ► Edit Components panel ► Edit Components



drop-down ► Edit.

- 2 Respond to the prompts as follows:

Select component/cable/location box to EDIT:

Select anywhere on the top portion of the PLC module

The Edit PLC Module dialog box displays.

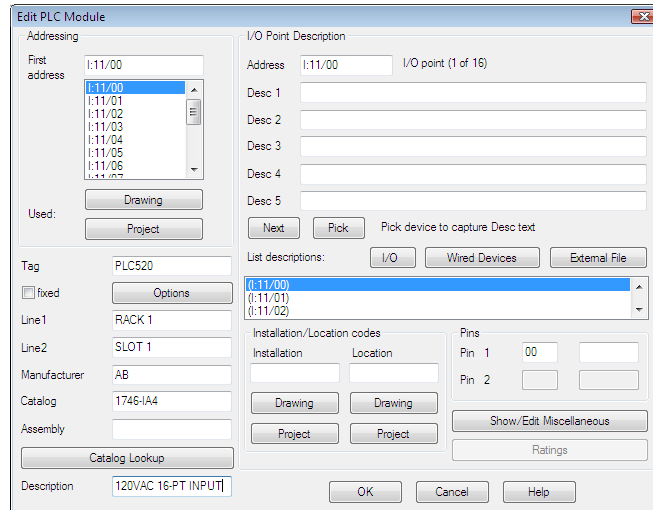

This dialog box provides spaces for you to enter description text for each I/O point. Assume that the descriptions already assigned to the connected limit switches are like what you want to use for the PLC I/O point descriptions.

- In the Edit PLC Module dialog box, click Wired Devices.  
AutoCAD Electrical follows the connected wire for each I/O point backwards. If it finds a connected component, the component description text is retrieved. Each description displays in a dialog box list.
- For the first I/O address (I:11/00), select the first description (PALLET ENTERING STATION) in the extracted device list.  
The Confirmation dialog box displays.

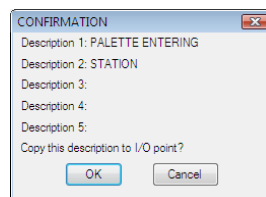

- Make sure that the correct description is specified and click OK.

- 6 Click Next to highlight I/O address 1:11/01 in the Addressing list. The corresponding device description highlights automatically.

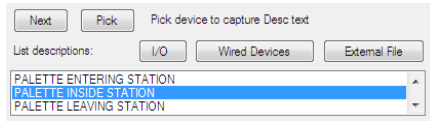

- 7 Select the highlighted description, PALLET INSIDE STATION, and click OK.
- 8 Repeat this process for the remaining I/O point.

---

**NOTE** Alternately you can use Pick to capture existing description text from a connected device. To do so, in the Edit PLC Module dialog box, click Pick, and then select the component whose text you want to copy. AutoCAD Electrical reads the existing DESC text values on the component and transfers a copy to the DESC boxes in the Edit PLC Module dialog box.

---

- 9 In the Edit PLC Module dialog box, click OK. Your descriptions appear on the module.

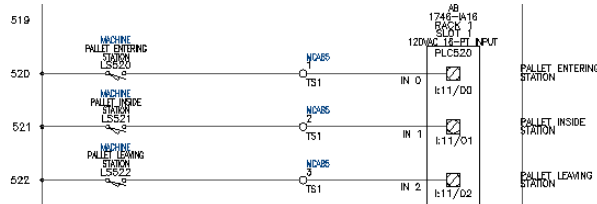



---

**NOTE** If your PLC description is not where you want it, use the Scoot tool to scoot the description to a new location.

---

# Schematic terminals

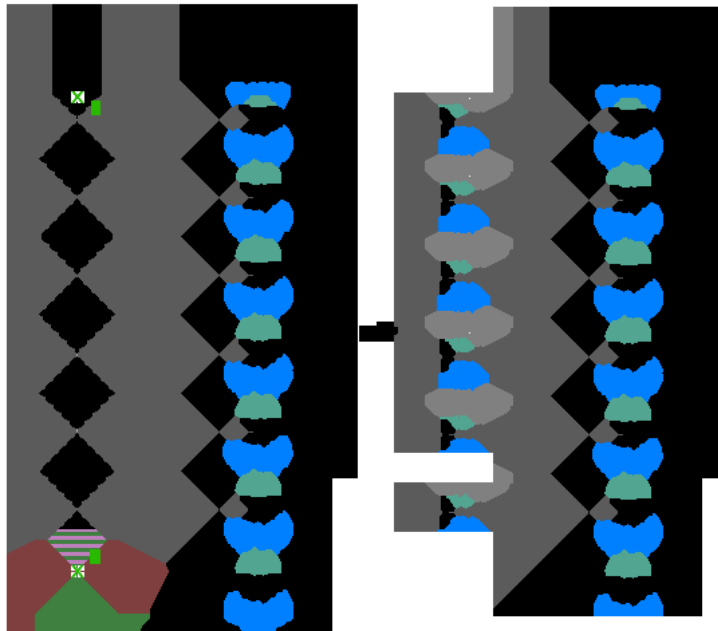
## Schematic terminals - Introduction



Insert and modify schematic terminals. Define multi-level schematic terminals.

Time required 45 minutes

Prerequisites: Copy all files located in

**Windows XP** *Documents and Settings\{username}\My Documents\Acade {version}\Aedata\Tutorial\Aegs\Schematic terminals*  
to  
*Documents and Settings\{username}\My Documents\Acade {version}\Aedata\Proj\Aegs*

**Windows Vista, Windows 7** *Users\{username}\Documents\Acade {version}\Aedata\Tutorial\Aegs\Schematic terminals*  
to  
*Users\{username}\Documents\Acade {version}\Aedata\Proj\Aegs*

You learn to:

- Understand terminal relationships
- Insert terminals
- Assign terminal block properties
- Define a multi-level terminal
- Associate terminals

## About schematic terminals

AutoCAD Electrical supports two types of relationships for terminals: schematic-to-schematic and schematic-to-panel.

---

**NOTE** Since one-line terminal symbols likely represent multiple, independent terminals, they cannot be associated to other schematic or panel terminals. A one-line terminal must be updated manually. A one-line terminal symbol is defined by a [WDTYPE attribute](#) on page 325 value of "1-".

---

### Schematic-to-Schematic

The schematic-to-schematic relationship defines separate schematic terminal symbols as one multi-level (also referred to as multi-tier or multi-stack) terminal block. On the schematic drawing, each schematic terminal symbol represents one level of the multi-level terminal block.

---

**NOTE** Multiple terminal symbols for one level are not currently supported.

---

The number of levels for the block is defined as a block property. Each level carries certain characteristics, such as a label, wires per connection, left pin, and right pin. Each schematic terminal symbol carries all the block properties for each level so that removing one terminal symbol does not remove the block properties. If a block property is modified, all the terminal symbols update.

An ID value held on the LINKTERM attribute or Xdata, associates the terminal symbols. When a terminal symbol is inserted, by default it is seen as a standalone terminal (it has no associations) and receives a new LINKTERM value. When the terminal is associated to another, the LINKTERM value updates so that each terminal carries the same LINKTERM value. Changing or removing the LINKTERM value breaks any associations that terminal has.



To associate schematic terminals, first add block properties. The number of terminals you can associate is limited to the number of levels defined in the block properties. Once block properties are established you can associate schematic terminals to build a multi-level terminal block by:

- Click Schematic tab ➤ Edit Components panel ➤  ➤ Associate



Terminals.

You select a master terminal and then select each terminal symbol to associate to the master.

- Clicking Pick on the Insert/Edit Terminal Symbol dialog box. It adds the edited symbol into an association with the picked terminal.
- Clicking Add/Modify on the Insert/Edit Terminal Symbol dialog box. It adds the edited symbol into an association with any schematic terminal in the project.



Prebuilt circuits can contain associated terminals. These relationships are maintained when the circuit is inserted. Copying a circuit also maintains these relationships within the copied circuit.

When the Bill of Materials report is run, these separate terminal symbols that make up one multi-level terminal, are counted as one in the quantity.

### **Schematic-to-Panel**

The schematic-to-panel relationship is used mainly for updating. If the schematic or panel is modified, the other updates to reflect the changes. This relationship is like component relationships, which are based on the TAG value. The TAGSTRIP, Installation, and Location values must match for the terminals to associate together. The association number on the LINKTERM is also taken into account when creating a relationship between the schematic terminal and its panel representation. Block properties are not required to associate a schematic to panel terminal. Once they are associated, modifications on one results in modifications on the other.

You can associate a schematic and panel terminal automatically by:

- Click Panel tab ► Terminal Footprints panel ►  ► Insert  
Terminals drop-down ► Insert Terminal (Schematic List) 
- Click Schematic tab ► Insert Components panel ► Insert Components  
drop-down ► Terminal (Panel List) 

For multi-level terminals, the Insert Terminal (Schematic List) tool shows only one terminal for insertion regardless of how many schematic terminal symbols/levels there are for that multi-level block. The Insert Terminal (Panel List) tool shows one terminal for each level for insertion.

---

**NOTE** Panel terminals inserted by the Terminal Strip Editor are automatically associated to the schematic representation.

---

You can click the [Associate terminals](#) on page 1055 tool to select terminals to associate or click Add/Modify on the Panel Layout - Terminal Insert/Edit dialog box to add the panel terminal to an association with a schematic terminal on any drawing in the project.

## Insert terminals

### Insert terminals

- 1 If AEGS is not the active project, in the Project Manager, right-click AEGS and select Activate.
- 2 In the Project Manager, double-click AEGS to expand the drawing list.
- 3 In the Project Manager, Project Drawing List, double-click *AEGS05.dwg*.
- 4 Click Schematic tab ► Insert Components panel ► Multiple Insert

drop-down ► Multiple Insert (Icon Menu) 

5 In the Insert Component: JIC Schematic Symbols dialog box, click



Terminals/Connectors.

6 In the JIC: Terminals and Connectors dialog box, click Round with



Terminal Number.

7 Respond to the prompts as follows:

Component Fence, From Point: *Select above wire at line reference 520 (1)*

Component Fence, From Point: to:

*Select below wire at line reference 535 (2), left click to end command, right-click to add terminal*

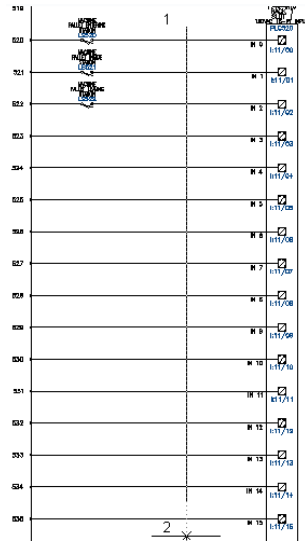

8 In the Keep dialog box, select Keep this one.

Click OK.

9 In the Insert/Edit Terminal Symbol dialog box, Terminal section, specify:

Location: MCAB5

Tag Strip: TS1

Number: 1

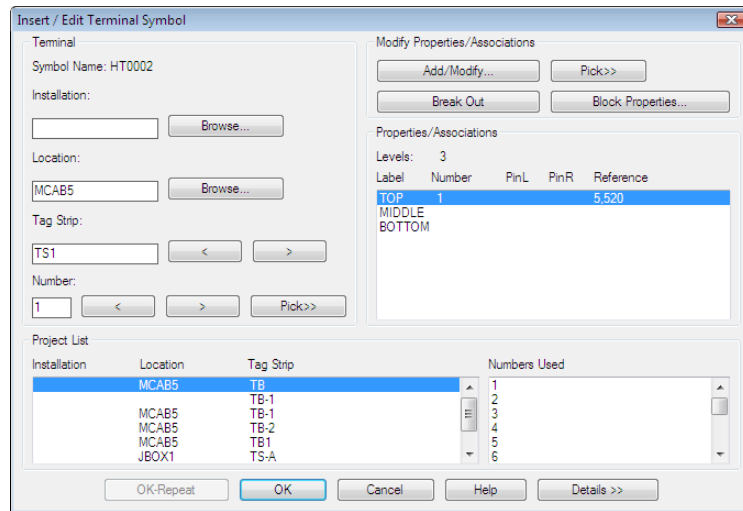

10 Click OK.

11 In the Keep dialog box, select:

Keep all, don't ask

Clear Show edit dialog box after each

Click OK

The terminals are automatically added to your drawing.

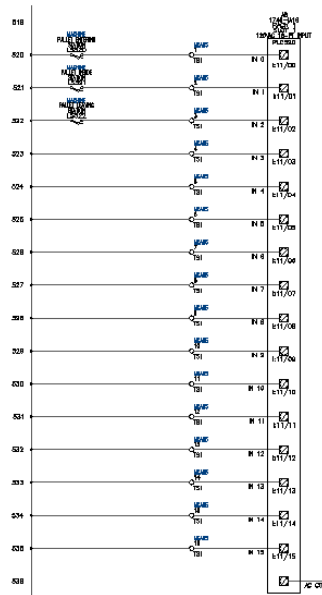

## Multi-level terminals

### Multi-level terminals

- 1 In the Project Manager, Project Drawing List, double-click *AEGS02.dwg*.
- 2 Click Schematic tab ► Edit Components panel ► Edit Components



drop-down ► Edit.

- 3 Select the round terminal on rung 217. The Insert/Edit Terminal Symbol dialog box displays, where you can annotate the terminal properties and associations.
- 4 In the Insert/Edit Terminal Symbol dialog box, Project List section, select Tag Strip TB.
- 5 Enter **Location:** MCAB5 and **Number:** 10.

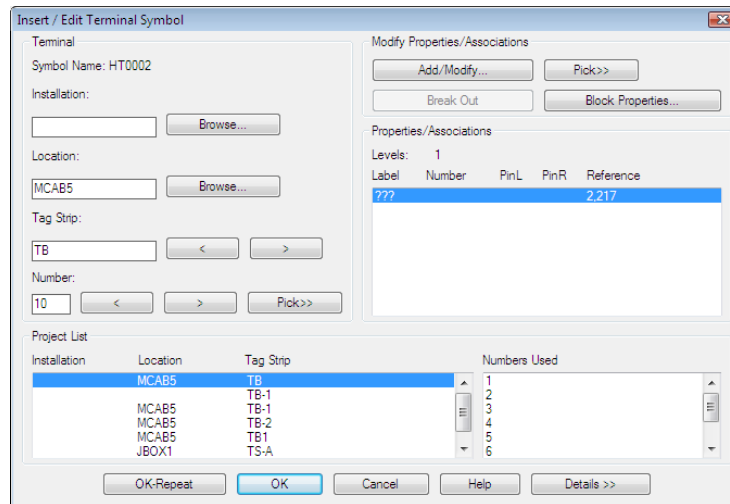

- 6 Click Details >>.
- 7 In the Catalog Data section, click Catalog Lookup.

- 8 On the Parts Catalog dialog box, click  to clear all predefined filters. Click Yes to confirm.

- 9 On the Parts Catalog dialog box each column has an edit field to enter search text. Enter:

Manufacturer: SIEMENS

Type: MULTI-LEVEL

Rating: 20 AMPS

- 10 Select part 8WA1 011-3JF16 and click OK.

The Manufacturer and Catalog information for the selected part displays in the Catalog Data section of the Insert/Edit Terminal Symbol dialog box.

- 11 On the Insert/Edit Terminal Symbol dialog box, click OK.

- 12 Click Schematic tab > Edit Components panel > Edit Components

drop-down >  > Edit.

- 13 Select the middle terminal between rungs 217 and 218. The Insert/Edit Terminal Symbol dialog box displays.
- 14 In the Insert/Edit Terminal Symbol dialog box, Project List section, select Tag Strip TB.
- 15 Enter **Location:** MCAB5 and **Number:** 11.

## Modify multi-level associations

### Modify multi-level terminal associations

- 1 On the Insert/Edit Terminal Symbol dialog box, Modify Properties/Associations section, click Add/Modify.
- 2 On the Add/Modify Association dialog box, Select Association section, expand the active project node. The active node is bold in the list.

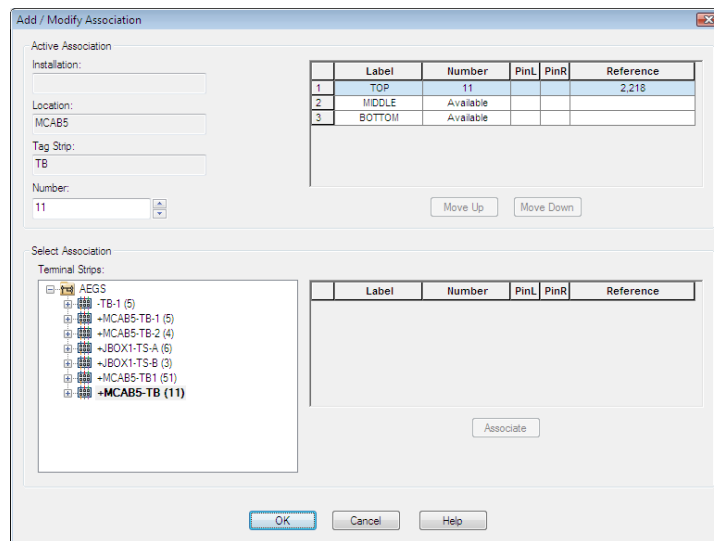

- 3 Select the terminal block node you inserted on line reference 217 (10, , (3)).

The terminal numbers defined on the block are listed, separated by commas. The number of levels defined in the block properties displays at the end of the node string in parenthesis. For example, 1,21,GND (3). An empty space represents a level not represented on the schematic: 1, ,

GND (3). A '???' represents a terminal assigned to the level, but the terminal does not have a number assignment: 1,???,GND (3).

---

**NOTE** The grid to the right populates with the definition for the selected terminal: Level 1 has Label = TOP, Number = 10, Reference = 2,217.

---

- 4 Select Level 2 in the grid and click Associate.

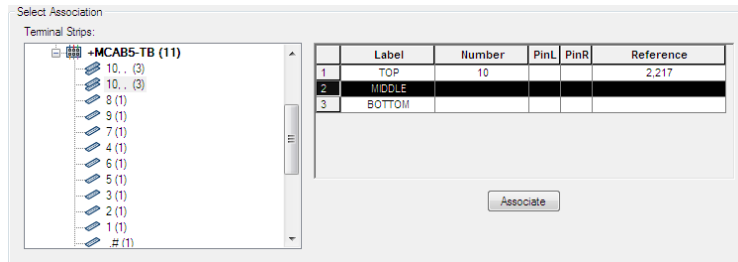

Once you click Associate, the middle level updates with the terminal number in the grid in the Active Association section of the dialog box.

- 5 Click OK.

The level assignments display in the Properties/Associations section of the Insert/Edit Terminal Symbol dialog box. Notice that the terminal is three levels and levels 1 and 2 are now assigned.

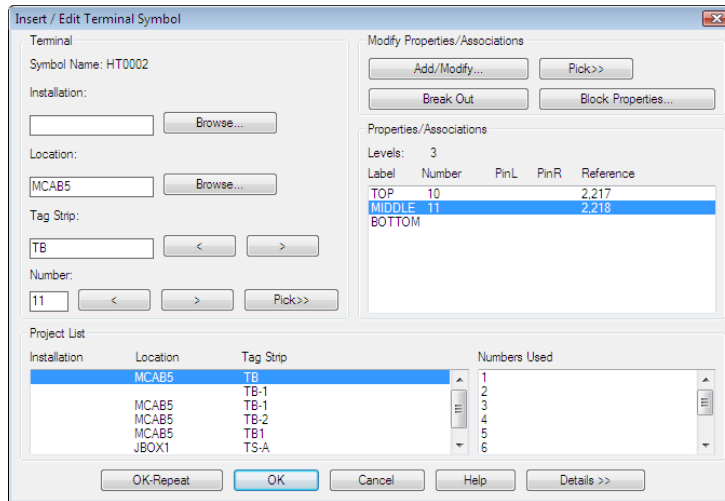

- 6 On the Insert/Edit Terminal Symbol dialog box, click OK.



- Click Schematic tab ► Edit Components panel ► Edit Components



drop-down ► Edit.

- Select the bottom terminal on rung 218. The Insert/Edit Terminal Symbol dialog box displays.
- In the Insert/Edit Terminal Symbol dialog box, Project List section, select Tag Strip TB.
- Enter **Location:** MCAB5 and **Number:** 12.
- On the Insert/Edit Terminal Symbol dialog box, Modify Properties/Associations section, click Add/Modify.
- On the Add/Modify Association dialog box, Select Association section, expand the active project node.
- Select the terminal block node you inserted on line reference 217 (10,11, (3)). Notice that the node properties updated to reflect that levels 1 and 2 are assigned and that level 3 is still blank/available.
- Select Level 3 in the grid and click Associate.

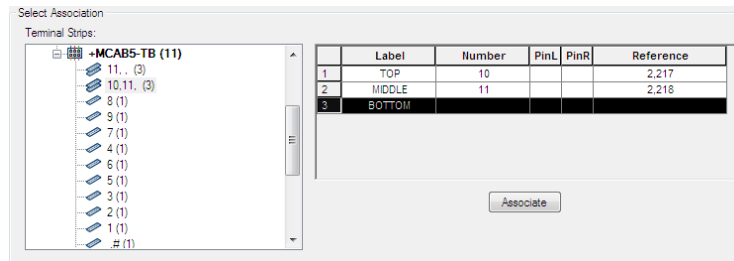

Once you click Associate, the bottom level updates with the terminal number in the grid in the Active Association section of the dialog box. You can rearrange the levels by selecting a level and clicking Move Up or Move Down.

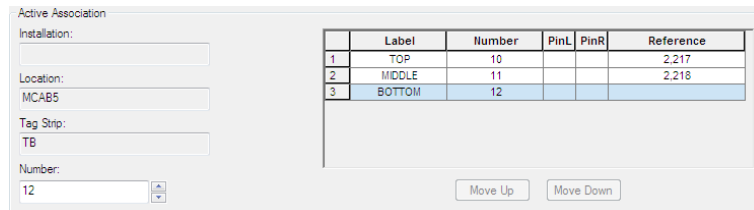

15 Click OK.

The level assignments display in the Properties/Associations section of the Insert/Edit Terminal Symbol dialog box. Notice that levels 1, 2, and 3 are now assigned.

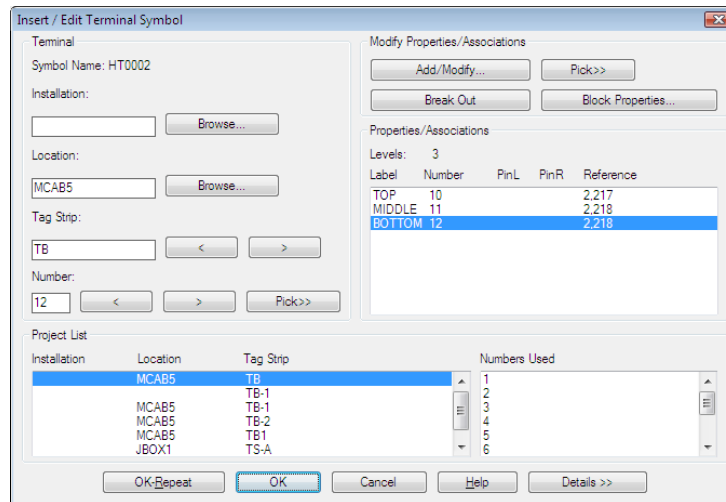

16 On the Insert/Edit Terminal Symbol dialog box, click OK.

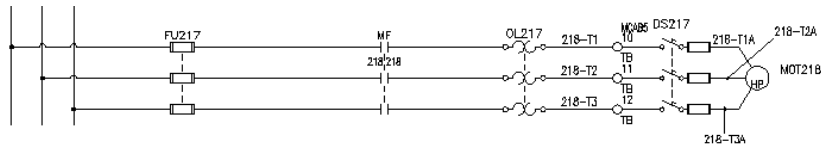

## Terminal Properties

You can modify an existing terminal to make it a multi-level terminal block and then associate terminals to the master terminal block.

### Modify terminal properties

- 1 Right-click terminal 4 on line reference 211 and select Edit Component.
- 2 On the Insert/Edit Terminal Symbol dialog box, Catalog Data section, delete the Manufacturer and Catalog information.
- 3 In the Modify Properties/Associations section, click Block Properties.

**4** On the Terminal Block Properties dialog box, specify:

Levels: 3

**Level 1**

Level Description: Top

Wires Per Connection: 2

PinL: 1

PinR: 2

**Level 2**

Level Description: Middle

Wires Per Connection: 2

PinL: 3

PinR: 4

**Level 3**

Level Description: Bottom

Wires Per Connection: 2

PinL: 5

PinR: 6

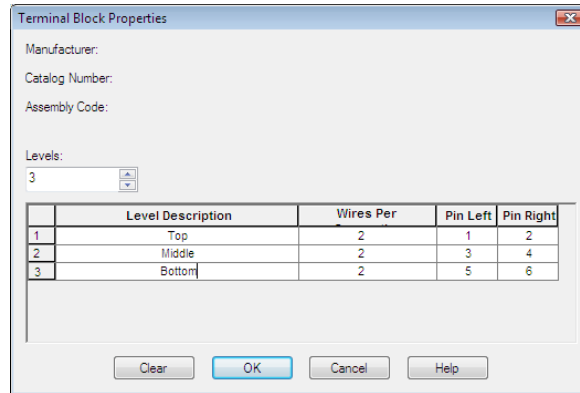

Click OK.

Notice on the Insert/Edit Terminal Symbol dialog box, Properties/Associations section that the block now has three levels. Terminal 4 is assigned to the top level of the block.

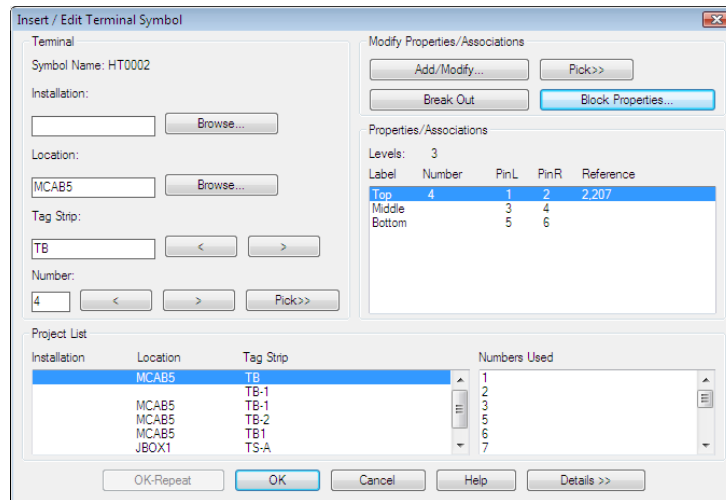

- 5 On the Insert/Edit Terminal Symbol dialog box, click OK.
- 6 On the Update other drawings dialog box, click OK.
- 7 If asked to save the drawing, click OK.

## Associate terminals

### Associate terminals

- 1 Click Schematic tab ➤ Edit Components panel ➤  ➤ Associate



Terminals.

- 2 Respond to the prompts as follows:

Select "Master" terminal: *Select terminal 4 on line reference 211*

Pick terminal: *Select terminal 5*

Pick terminal: *Select terminal 6, right-click*

---

**NOTE** The command prompt area indicates that the terminal was added as level 02 or level 03 once you pick the terminal.

---

3 Right-click terminal 6 and select Edit Component.

On the Insert/Edit Terminal Symbol dialog box, Properties/Associations section, all three levels have been assigned. You can now move a terminal to another level using the Add/Modify Association dialog box.

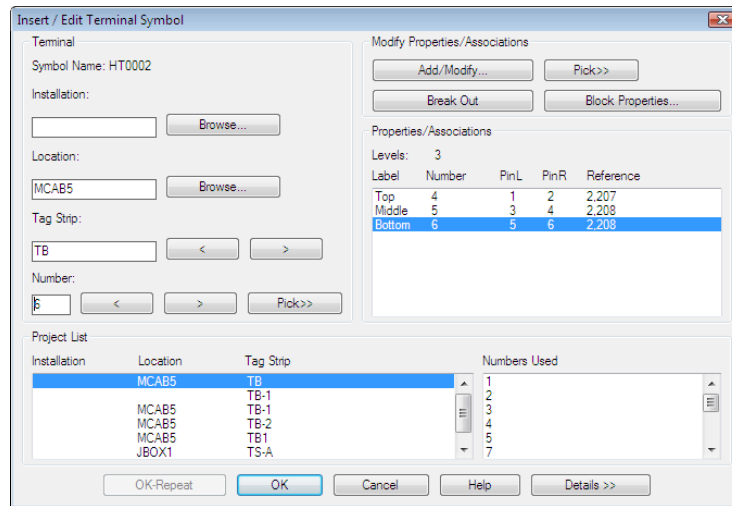

4 On the Insert/Edit Terminal Symbol dialog box, Modify Properties/Associations section, click Add/Modify.

5 On the Add/Modify Association dialog box, Active Association section, highlight level 3 in the grid and click Move Up.

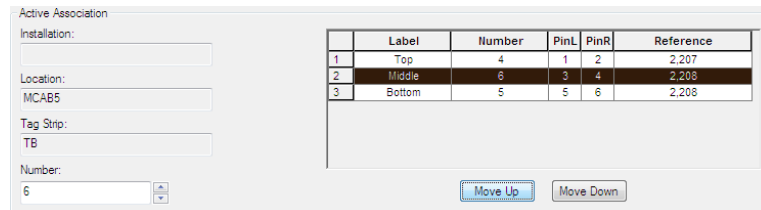

The grid updates to reflect the move. Notice that terminal 6 is now assigned to level 2.

6 Click OK.

7 On the Insert/Edit Terminal Symbol dialog box, click OK.

8 If asked to update related components, click Yes-Update.

---

**NOTE** If the terminals are not all on the same drawing you can associate them using the Add/Modify Association dialog box.

---

## Wire numbers

### Wire numbers - Introduction

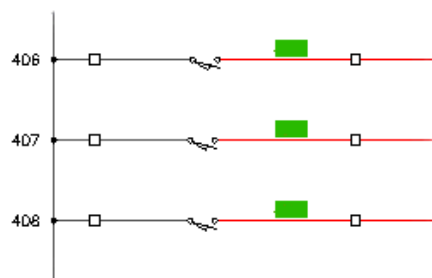

Insert wire numbers and signal arrows.

Time required 45 minutes

Prerequisites: Copy all files located in

**Windows XP** *Documents and Settings\{username}\My Documents\Acade {version}\Aedata\Tutorial\Aegs\Wire numbers*  
to  
*Documents and Settings\{username}\My Documents\Acade {version}\Aedata\Proj\Aegs*

**Windows Vista,  
Windows 7** *Users\{username}\Documents\Acade {version}\Aedata\Tutorial\Aegs\Wire numbers*  
to  
*Users\{username}\Documents\Acade {version}\Aedata\Proj\Aegs*

You learn to:

- Understand wire numbers
- Insert wire numbers
- Insert I/O based wire numbers

- Delete wire numbers
- Understand signal arrows
- Insert a source arrow
- Insert a destination arrow

## About wire numbers

Wire numbers can be assigned to any existing wires on an individual selection, an entire drawing, selected drawings in a project, or an entire project.

AutoCAD® Electrical assigns a unique wire number to each wire network. A wire network consists of one or more wires that are electrically connected.

## Inserting wire numbers

You can process and tag wires with sequential wire numbers or with wire numbers based upon the line reference location start of the wire network. When wire numbers are automatically inserted into a drawing, the numbers are not duplicated.

AutoCAD Electrical works from left to right, top to bottom as it processes wire networks by default. You can change the direction of wire numbering using the Project Properties ► Wire Numbers dialog box (in the Project Manager. Right-click the project name, and select Properties. In the Project Properties dialog box, click the Wire Numbers tab).

### Insert wire numbers automatically

- 1 If AEGS is not the active project, in the Project Manager, right-click AEGS and select Activate.
- 2 In the Project Manager, double-click AEGS to expand the drawing list.
- 3 In the Project Manager, Project Drawing List, double-click *AEGS04.dwg*.
- 4 Zoom in on the top portion of the wire network on the left side of the drawing.

- 5 Click Schematic tab ► Insert Wires/Wire Numbers panel ► Insert Wire



Numbers drop-down ► Wire Numbers.

- 6 In the Sheet 4 - Wire Tagging dialog box, click Pick Individual Wires.

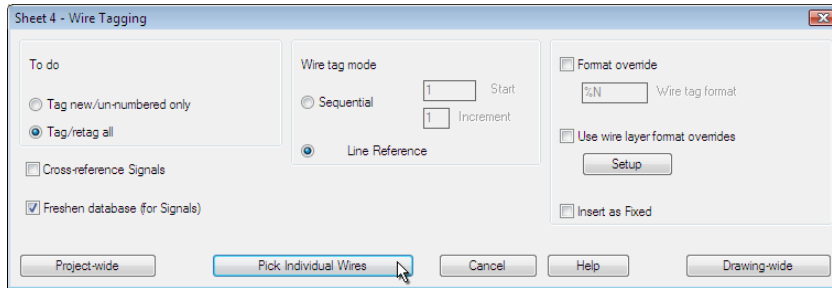

- 7 Respond to the prompts as follows:

Select objects:

Select the wire segment between the two push buttons on line reference 403 (1), right-click

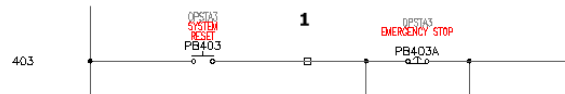

The wire number is placed.

## Add wire numbers to the entire drawing

- 1 Click Schematic tab ► Insert Wires/Wire Numbers panel ► Insert Wire



Numbers drop-down ► Wire Numbers.

- 2 In the Sheet 4 - Wire Tagging dialog box, click Drawing-wide. Wire numbers are assigned to each segment in your drawing.



## Add wire numbers project-wide

- 1 Click Schematic tab ► Insert Wires/Wire Numbers panel ► Insert Wire

Numbers drop-down ► Wire Numbers.



- 2 In the Sheet 4 - Wire Tagging dialog box, click Project-wide.

- 3 In the Wire Tagging (Project-wide) dialog box, verify:

Wire tag mode: Reference-based tags

To do: Tag/retag all

Freshen database (for Signals)

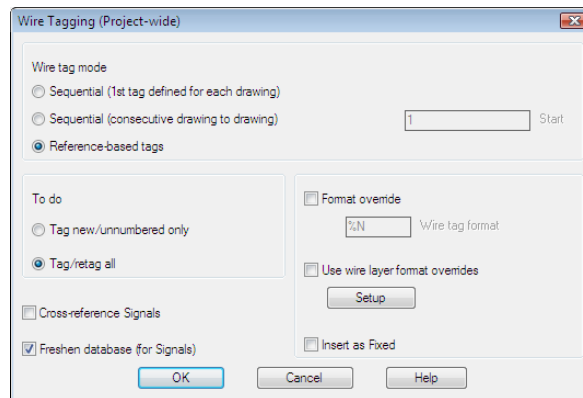

- 4 Click OK.
- 5 In the Select Drawings to Process dialog box, Project Drawing List section, press SHIFT as you select *AEGS03.dwg* and *AEGS004.dwg*. Click Process.
- 6 Verify *AEGS03.dwg* and *AEGS04.dwg* are listed as the drawings to process and click OK.
- 7 If asked to save the drawing, click OK.  
Wire numbers are processed for the selected drawings.

## Inserting I/O based wire numbers

You can insert wire numbers based on the I/O address that each PLC connected wire touches. The wire numbers insert with your specified format as fixed wire

numbers. If a wire number retag is run later on, fixed wire numbers do not change.

---

**NOTE** If you want PLC I/O based wire numbering to be the automatic default for a drawing, set it up in the Drawing Properties dialog box. Select the Search for PLC I/O address on insert toggle.

---

## Insert PLC I/O wire numbers

- 1 Open *AEGS05.dwg*.
- 2 Click Schematic tab ► Insert Wires/Wire Numbers panel ► Insert Wire



Numbers drop-down ► PLC I/O.

The PLC I/O Wire Numbers dialog box displays.

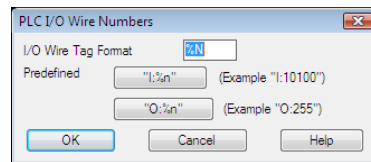

The default format is %N, the address number. The wire number is the same as its connected I/O address number.

- 3 Click I:%n to change the wire number format.  
It adds an 'I' prefix to each wire number that ties to the input module.
- 4 Click OK.
- 5 Respond to the prompts as follows:  
select I/O module to process: *Select anywhere on the PLC module*  
select objects: *Select all the connected wires to process, right-click*

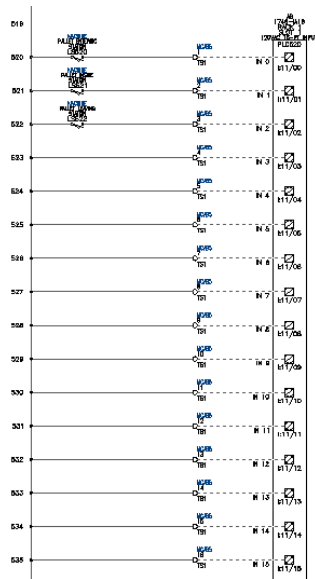

The wire numbers are inserted with the specified format. If some of the I/O points short-circuit to other I/O points, the last point wire number prevails for that common wire network.

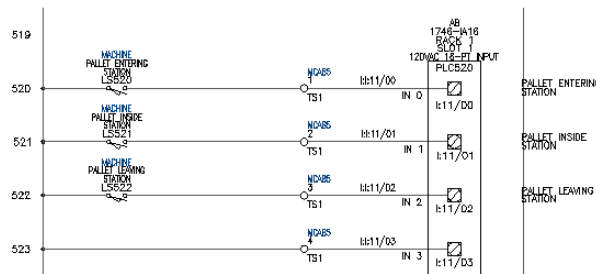

## Deleting a wire number

You can use the Delete Wire Numbers tool to select a wire number or to pick on any wire of the network.

## Delete a wire number

- 1 Click Schematic tab ► Edit Wires/Wire Numbers panel ► Delete Wire



- 2 Respond the prompts as follows:

Select objects: *Enter all, press ENTER*

The wires in the network change to dashed lines, representing the wires from which the wire numbers will be erased.

- 3 Press ENTER again to erase the wire numbers.

## Source signal arrows

AutoCAD Electrical uses a named source/destination concept. You identify a wire network to be the source, insert a source arrow on that network, and assigning a source code name to it. On the wire network that is to be a continuation of the same wire number (whether on the same drawing or a different drawing in the project), insert a destination arrow. Give it the same code name that you gave to its source. AutoCAD Electrical reprocesses your drawing set for wire numbering update. It matches source code names with destination names and copies source wire numbers over to the destination wire networks.

You can attach a source signal to a wire segment of a wire network. It enables the wire number assigned to the network to jump and continue to another network on the current drawing or on one or more drawings in the project. The source and destination are also helpful with the Wire From/To reports and connection information.

### Attach a source signal arrow

- 1 Open *AEGS03.dwg*.
- 2 Click Schematic tab ► Insert Wires/Wire Numbers panel ► Signal Arrows



- 3 Respond to the prompts as follows:

Select wire end for Source:

Select the end of the hot wire on the schematic on the right side of the drawing at line reference 332 (1)

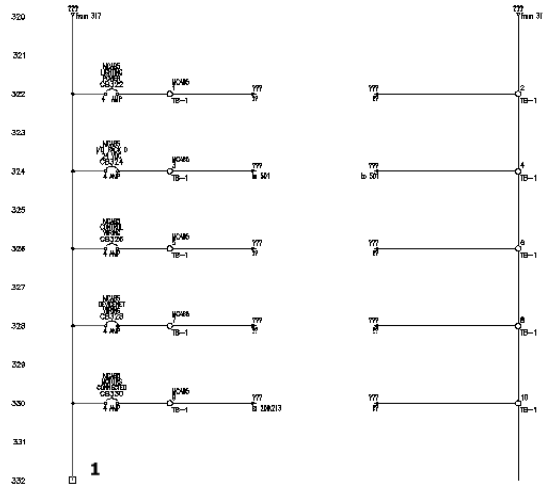

4 In the Signal - Source Code dialog box, specify:

Code: 24 VDC

Signal Arrow Style: 1

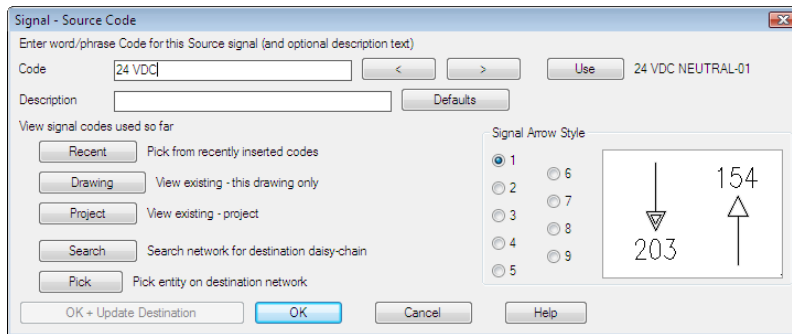

AutoCAD Electrical allows one description line on a source arrow. This description can then be carried over to the associated destination arrow. You can define some default description lines to make them easier to enter without typing them in each time. AutoCAD Electrical looks for a file called *WDSRCDST.WDD*. This file is a simple text file with each line being read as a separate description. If this file exists, the Defaults button

is available on the Signal - Source Code and Insert Destination Code dialog boxes.

- 5 Click OK.
- 6 In the Source/Destination Signal Arrows dialog box, click No.

---

**NOTE** Click No to insert the signal arrows on the next drawing. Click OK to insert the signal arrows on the current drawing.

---

- 7 To access *AEGS04.dwg*



Click Project tab ► Other Tools panel ► Next DWG.

Now you are ready to insert a destination signal arrow.

## Destination signal arrows

After the source signal arrow is attached to a wire in the drawing, you can attach a destination signal to a wire segment of a wire network. It enables the wire number assigned to another source wire network to carry over to the current network automatically.

### Attach a destination signal

- 1 Click Schematic tab ► Insert Wires/Wire Numbers panel ► Signal Arrows



drop-down ► Destination Arrow.

- 2 Respond to the prompts as follows:

Select wire end for Destination:

*Select the top of the hot wire on the schematic on the left side of the drawing at line reference 402 (2)*

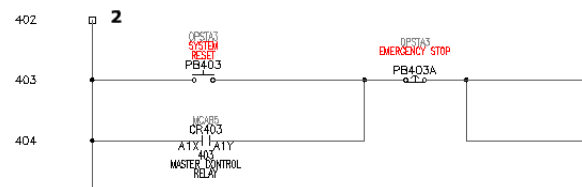

3 In the Insert Destination Code dialog box, click Project.

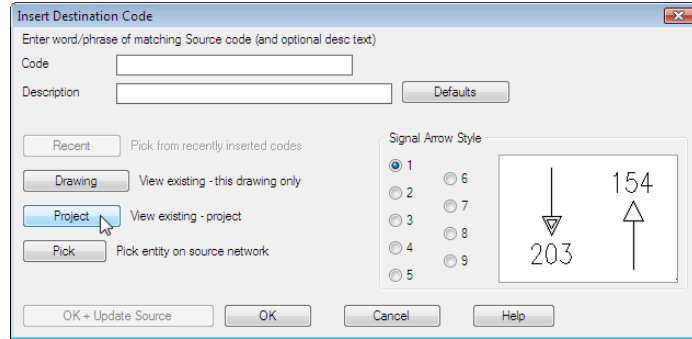

4 In the Signal codes -- Project-wide Source dialog box, select the following:

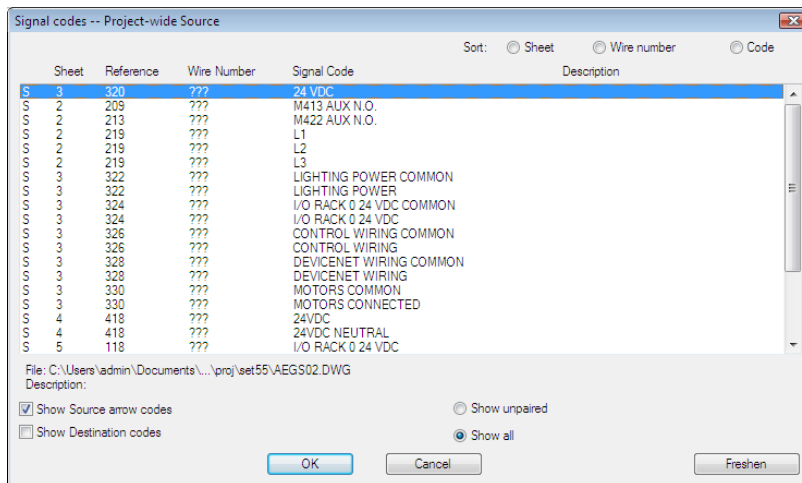

5 Click OK.

6 In the Insert Destination Code dialog box, verify:

Code: 24 VDC

Signal Arrow Style: 1

Click OK + Update Source.

The cross-references for your signal insert into the drawing above the hot wire.



## Attach source and destination signals to the neutral wires.

- 1 To return to *AEGS03.dwg*

Click Project tab ► Other Tools panel ► Previous DWG.



- 2 Click Schematic tab ► Insert Wires/Wire Numbers panel ► Signal Arrows



drop-down ► Source Arrow.

- 3 Respond to the prompts as follows:

Select wire end for Source:

Select the bottom of the neutral wire at line reference 332 (3)

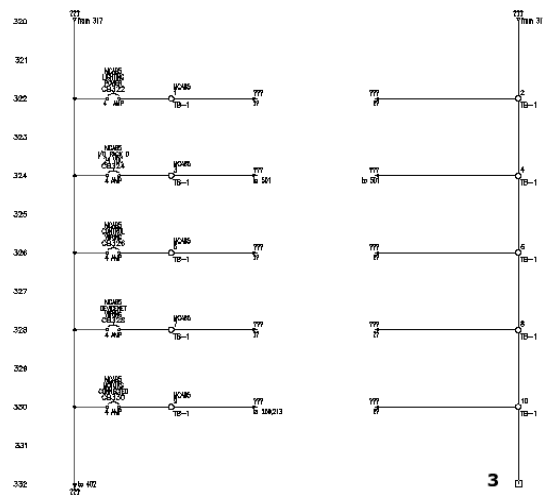

- 4 In the Signal - Source Code dialog box, specify:

Code: 24 VDC NEUTRAL

Click OK.



5 In the Source/Destination Signal Arrows dialog box, click No.

**NOTE** Click No to insert the signal arrows on the next drawing. Click OK to insert the signal arrows on the current drawing.

6 To open *AEGS04.dwg*

Click Project tab ► Other Tools panel ► Next DWG.



7 Click Schematic tab ► Insert Wires/Wire Numbers panel ► Signal Arrows

drop-down ► Destination Arrow.



8 Respond to the prompts as follows:

Select wire end for Destination:

Select the top of the neutral wire at line reference 402 (4)



9 In the Insert Destination Code dialog box, click Project.

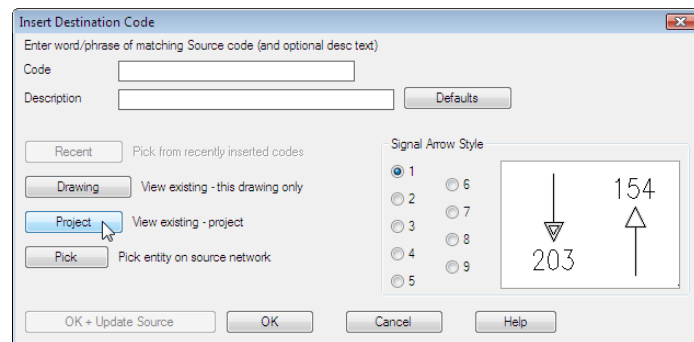

10 In the Signal codes -- Project-wide Source dialog box, select the following:

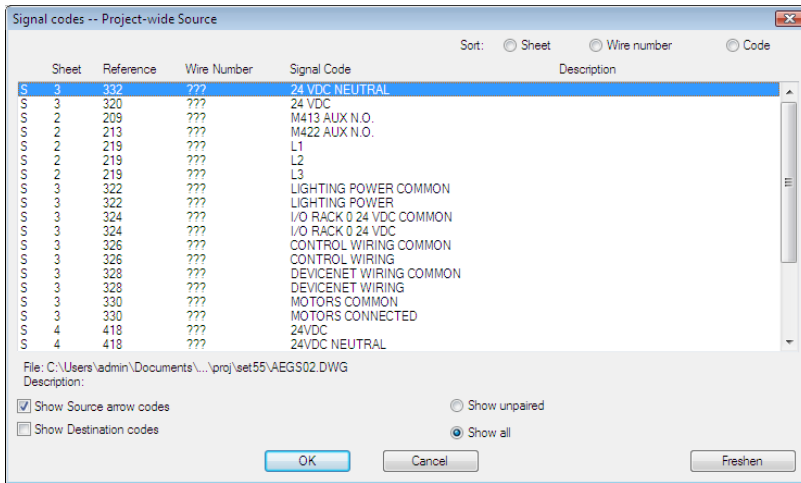

11 Click OK.

12 In the Insert Destination Code dialog box, verify:

Code: 24 VDC NEUTRAL

Signal Arrow Style: 1

Click OK + Update Source.

---

**NOTE** If asked to change the destination wire layer, click Yes.

---

The cross-references for your signal insert into the drawing above the neutral wire.

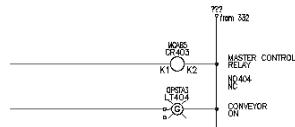

13 Click Schematic tab ► Edit Wires/Wire Numbers panel ►  ► Show



Signal Paths.

Temporary graphics illustrate the flow of the signals on your drawings.

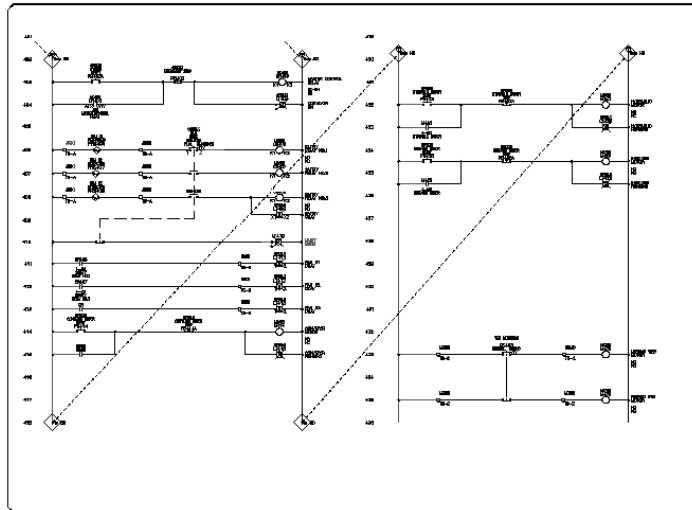

**NOTE** There is no limit to the number of source and destination links you can set up. One source network can jump to multiple destinations on one or many drawings. A wire can carry both a destination signal and a source signal pointing to the next daisy-chained destination.

## Panel layout

### Panel layout - Introduction

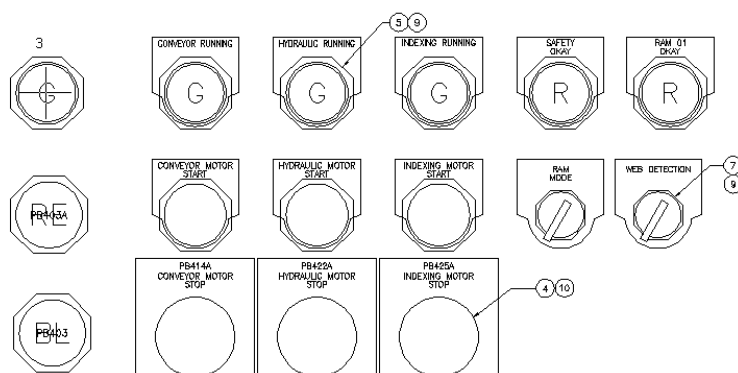

Insert and edit panel footprints. Insert and modify a graphical terminal strip with Terminal Strip Editor.

Time required	45 minutes
Prerequisites:	Copy all files located in
<b>Windows XP</b>	<i>Documents and Settings\{username}\My Documents\Acade {version}\Aedata\Tutorial\Aegs\Panel layout</i> to <i>Documents and Settings\{username}\My Documents\Acade {version}\Aedata\Proj\Aegs</i>
<b>Windows Vista, Windows 7</b>	<i>Users\{username}\Documents\Acade {version}\Aedata\Tutorial\Aegs\Panel layout</i> to <i>Users\{username}\Documents\Acade {version}\Aedata\Proj\Aegs</i>

You learn to:

- Insert panel footprints based on schematic components
- Insert nameplates
- Use the Terminal Strip Editor

## Insert Footprint (Schematic list)

Using the AutoCAD Electrical Panel Layout tools, you can select from a list of schematic components. Place the footprint component directly into a panel layout. The footprint remains linked to the original schematic component, so you can perform bidirectional updating between schematic components and the associated footprint blocks.

### Select schematic component footprints

- 1 If AEGS is not the active project, in the Project Manager, right-click AEGS and select Activate.
- 2 In the Project Manager, double-click AEGS to expand the drawing list.
- 3 Open *AEGS08.dwg*.

- 4 Click Panel tab ► Insert Component Footprints panel ► Insert Footprints



drop-down ► Schematic List.

- 5 In the Schematic Component List -- Panel Layout Insert dialog box, verify:

Extract component list for: Project

Location Codes to extract: All

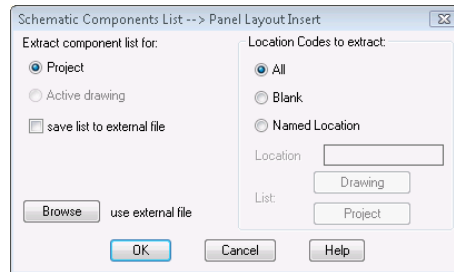

- 6 Click OK.
- 7 In the Select Drawings to Process dialog box, select *AEGS04.dwg* and click Process.
- 8 Verify that *AEGS04.dwg* is listed in the Drawing to Process section and click OK.
- 9 In the Schematic Components (active project) dialog box, click Mark Existing. An *x* marks the footprints that are already placed in the project. You cannot insert the same component multiple times. If you select an item with an *x*, the Insert button is disabled.

---

**NOTE** An *o* next to a component in the list indicates that a panel component with a matching component tag was found, but the catalog information does not match.

---

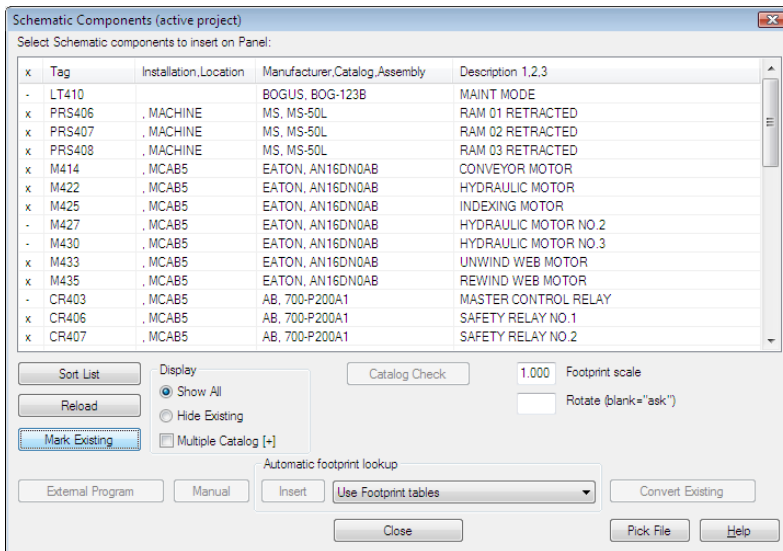

**10** In the Schematic Components (active project) dialog box, Display section, select Hide Existing.

The schematic component footprints not yet inserted into the panel layout are displayed.

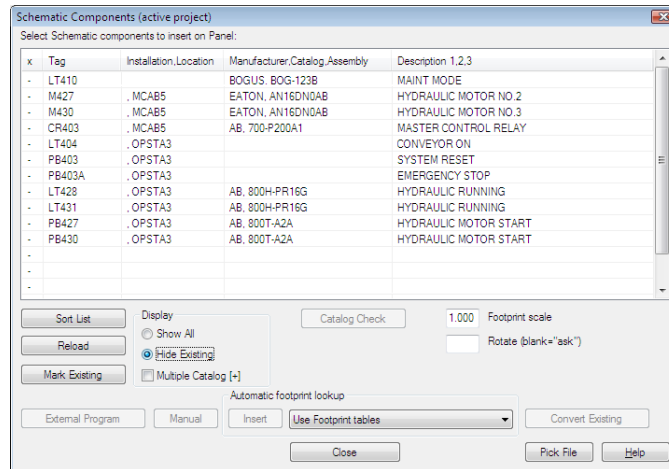

Now you can begin to insert schematic component footprints manually on the panel layout.

## Insert the system reset footprint manually

- 1 In the Schematics Components (active project) dialog box, select PB403 OPSTA3 SYSTEM RESET.

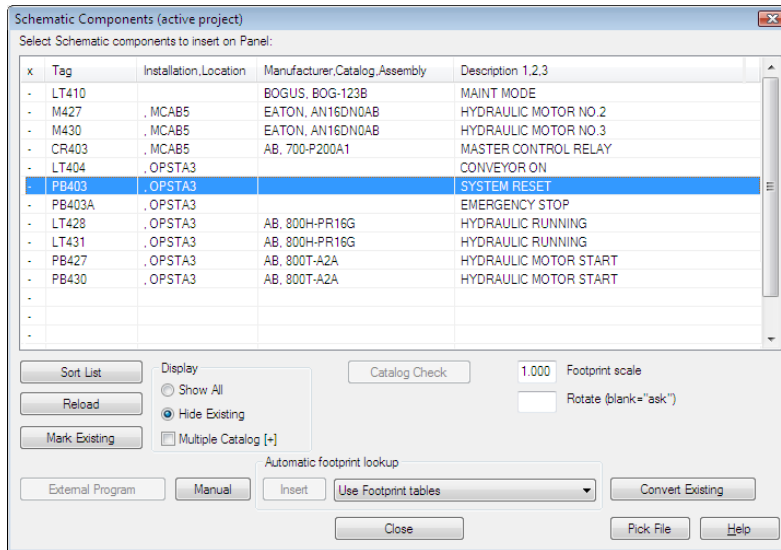

- 2 Click Manual.

**NOTE** The Manual button is used when schematic component footprints do not have a manufacturer and catalog number defined.

The next step is to make a catalog assignment for the automatic footprint.

- 3 In the Footprint dialog box, Choice A section, click Catalog lookup.

**NOTE** Use Choice B to enter a graphic without selecting a catalog number.



- 4 On the Parts Catalog dialog box, click  to clear all predefined filters. Click Yes to confirm.
- 5 On the Parts Catalog dialog box each column has an edit field to enter search text. Enter:

MANUFACTURER: AB

CATALOG: 800T

- Change the catalog assignment to 800T-A2A 1 NO 1 NC BLACK PUSH BUTTON - MOMENTARY, NEMA 4/13 and click OK.

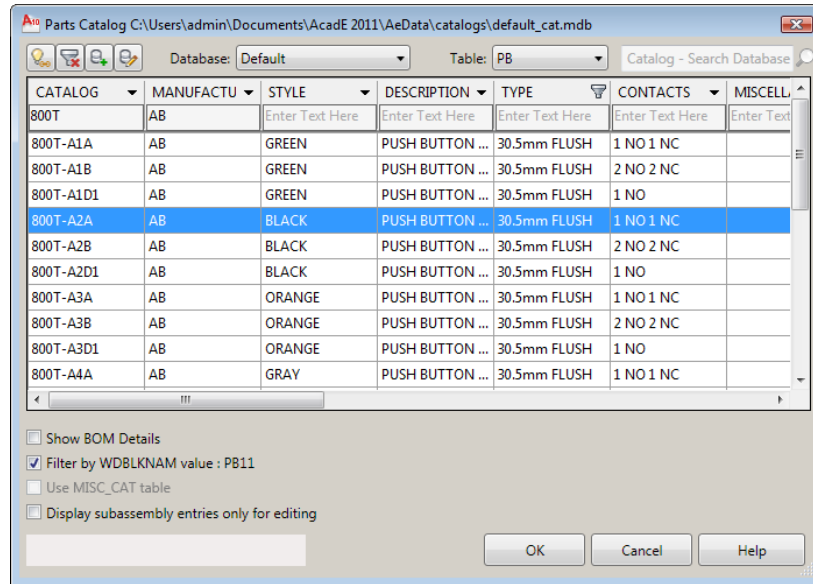

- In the Footprint dialog box, Choice A section, verify:

Manufacturer: AB

Catalog: 800T-A2A

Click OK.

- Respond to the prompts as follows:

Select Location for PB403: *Select to the left of PB414A (1)*

Select Location for PB403: <Ortho on> select ROTATION:

*Right-click to place the push button*



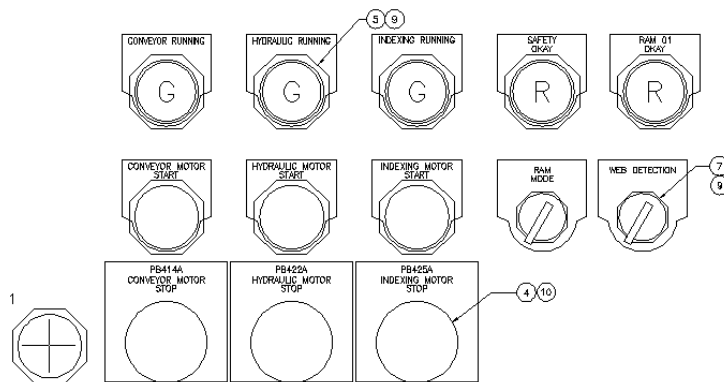

The component may already have an Item Number assigned. If AutoCAD Electrical finds a component with the same catalog information, it automatically assigns the same item number to this new component. If no item number is assigned, and you think a matching component exists, use one of the Find buttons to look through the drawing or project. If no matching component is found, click Next to assign an item number to this footprint. This button updates each time you insert a footprint and assign an item number. This item or detail number is used for BOM and component reporting and can be referenced by optional balloon labels tied to the footprint. If you do not want the item number to change if Resequence Item Numbers is run later on, check fixed next to the item number.

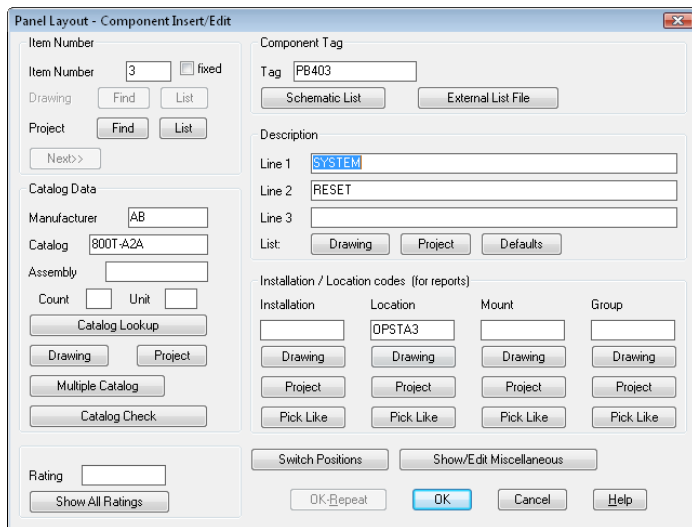

---

**NOTE** The Panel Layout - Component Insert/Edit dialog box displays each time you insert a panel footprint. Information from the schematic representation is automatically carried over to the panel footprint representation.

---

- 9 In the Panel Layout - Component Insert/Edit dialog box, click OK.  
The Schematics Component (active project) dialog box redisplay. You can continue inserting components from the schematic list of the project.

## Insert the emergency stop footprint manually

- 1 In the Schematic Components (active project) dialog box, select: PB403A OPSTA3 EMERGENCY STOP.

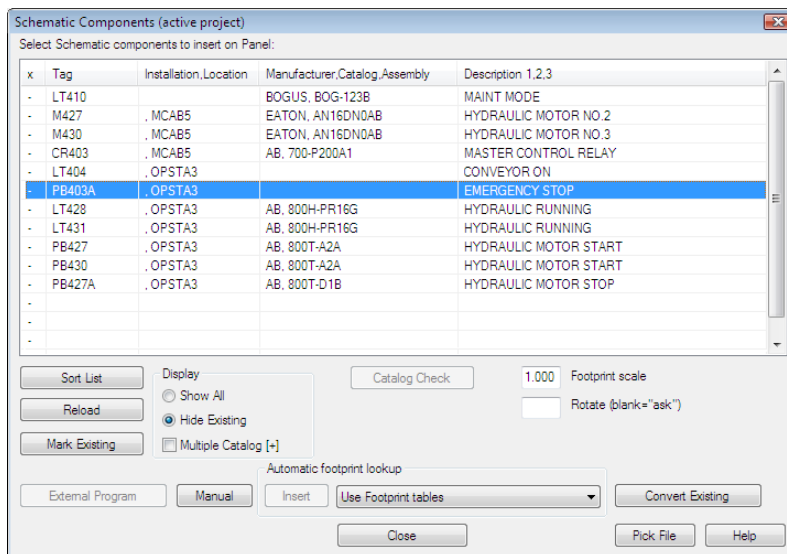

- 2 Click Manual.
- 3 In the Footprint dialog box, Choice A section, click Catalog lookup.

- 4 On the Parts Catalog dialog box, click  to clear all predefined filters. Click Yes to confirm.
- 5 On the Parts Catalog dialog box each column has an edit field to enter search text. Enter:

Manufacturer: AB

Type: 30.5mm

Style: Red

**6** Change the catalog assignment to 800T-D6A 1NO-1NC PUSH BUTTON-MUSHROOM, NEMA 4/13 and click OK.

**7** In the Footprint dialog box, Choice A section, verify:

Manufacturer: AB

Catalog: 800T-D6A

Click OK.

**8** Respond to the prompts as follows:

Select Location for PB403A: *Select to the left of Conveyor Motor Start (2)*

Select Location for PB403A: <Ortho on> select ROTATION:

*Right-click to place the push button*

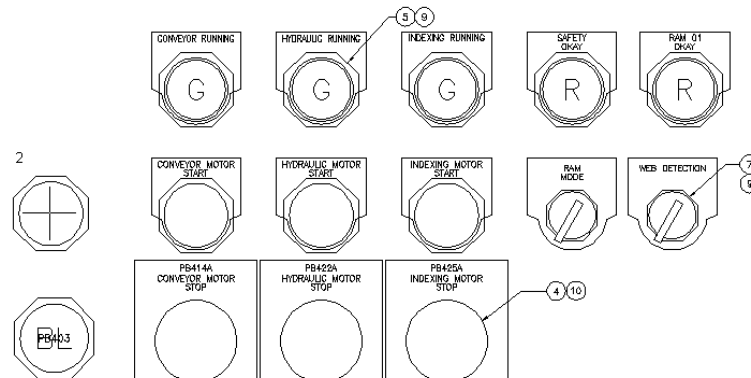

**9** In the Panel Layout - Component Insert/Edit dialog box, click OK.

## Insert the light footprint manually

**1** In the Schematic Components (active project) dialog box, select LT404 OPTSTA3 CONVEYOR ON.

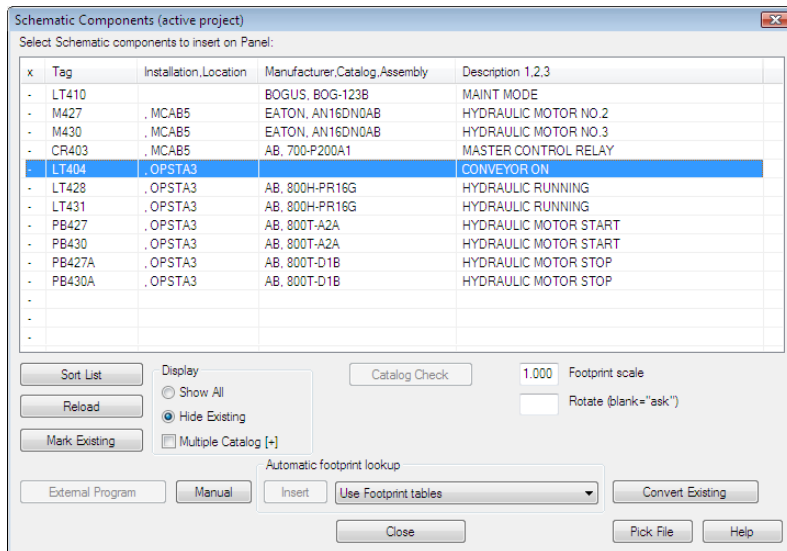

- 2 Click Manual.
- 3 In the Footprint dialog box, Choice A section, click Catalog lookup.



- 4 On the Parts Catalog dialog box, click  to clear all predefined filters. Click Yes to confirm.
- 5 On the Parts Catalog dialog box each column has an edit field to enter search text. Enter:  
MANUFACTURER: AB  
TYPE: 30.5mm
- 6 Change the catalog assignment to 800H-QRT24G PLASTIC LENS 24VAC/VDC FULL VOLT GREEN PILOT and click OK.

---

**NOTE** Click a column header to sort the catalog records based on the values in a specific field.

---

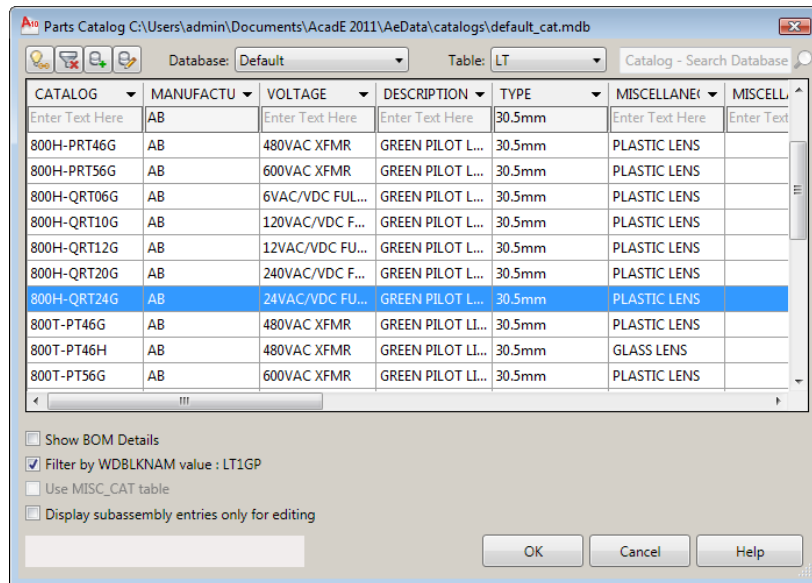

7 In the Footprint dialog box, Choice A section, verify:

Manufacturer: AB

Catalog: 800H-QRT24G

Click OK.

8 Respond to the prompts:

Select Location for LT404:

*Select to the left of the Conveyor Running light (3)*

Select Location for LT404: <Ortho on> select ROTATION:

*Right-click to place the pilot light*

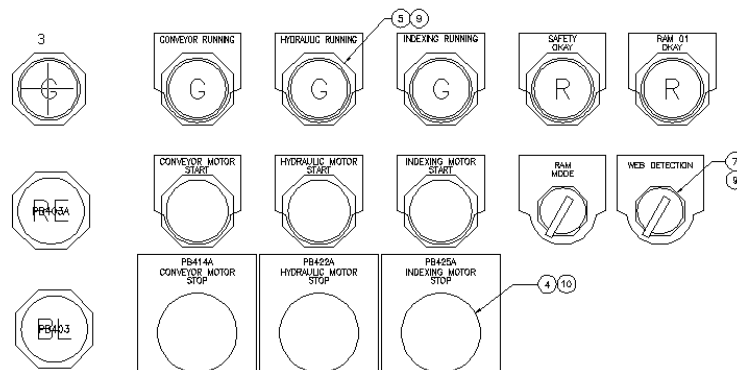

- 9 In the Panel Layout - Component Insert/Edit dialog box, click OK.  
In the Schematics Components (active project) dialog box, notice the master control relay must still be placed.
- 10 In the Schematic Components (active project) dialog box, click Close.

---

**NOTE** You can modify a footprint at any time using the Edit Footprint tool. Since there is bidirectional update capabilities between the schematics and the panel layout drawings, it is possible to introduce some inconsistencies between the two during edit. AutoCAD Electrical alerts you to check other drawings first, and then update any affected drawings.

---

- 11 In the Update other drawings dialog box, click OK.
- 12 If asked to save the drawing, click OK.

## Adding nameplate footprints

You can add nameplates to the panel layout. Nameplates are associated with existing component footprints. Nameplates can be inserted from the main panel icon menu or from a vendor menu.

### Insert an automotive type nameplate

- 1 Click Panel tab ► Insert Component Footprints panel ► Insert Footprints



drop-down ► Icon Menu.

2 In the Insert Footprint: Panel Layout Symbols dialog box, click

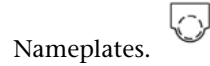

3 In the Panel: Nameplates dialog box, click Nameplate, Catalog Lookup.



4 In the Nameplate dialog box, Choice A section, click Catalog Lookup.



5 On the Parts Catalog dialog box, click  to clear all predefined filters. Click Yes to confirm.

6 On the Parts Catalog dialog box each column has an edit field to enter search text. Enter:

MANUFACTURER: AB

TYPE: 800T Automotive

7 Change the catalog assignment to 800T-X701 Red Blank Name Plate and click OK.

8 In the Nameplate dialog box, Choice A section, verify:

Manufacturer: AB

Catalog: 800T-X701

Click OK.

9 Respond to the prompts as follows:

Select objects: *Select PB403 (1), right-click to the place the nameplate*

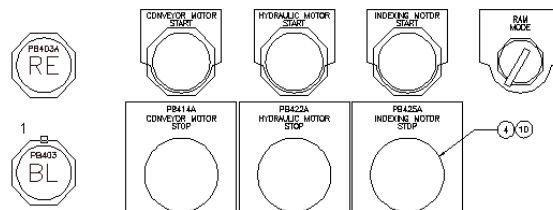

As you select each footprint to insert, the nameplate block inserts. The Panel Layout - Nameplate Insert/Edit dialog box displays where you can annotate the nameplate and assign a BOM item number if needed.

10 In the Panel Layout - Nameplate Insert/Edit dialog box, click OK.

---

**NOTE** A tag name links the data on the nameplate a tag name to the footprint and to the schematic component of the same name. Changing the tag name of any of these three representations triggers a prompt for permission to update the other related instances.

---

## Insert a half round nameplate

1 Click Panel tab ► Insert Component Footprints panel ► Insert Footprints



drop-down ► Icon Menu.

2 In the Insert Footprint: Panel Layout Symbols dialog box, click



Nameplates.

3 In the Panel: Nameplates dialog box, click Nameplate, Catalog Lookup.



4 In the Nameplate dialog box, Choice A section, click Catalog Lookup.



5 On the Parts Catalog dialog box, click  to clear all predefined filters. Click Yes to confirm.

6 On the Parts Catalog dialog box each column has an edit field to enter search text. Enter:

MANUFACTURER: AB

TYPE: 800T

7 Change the catalog assignment to 800T-X59E Gray Custom Text Name Plate and click OK.



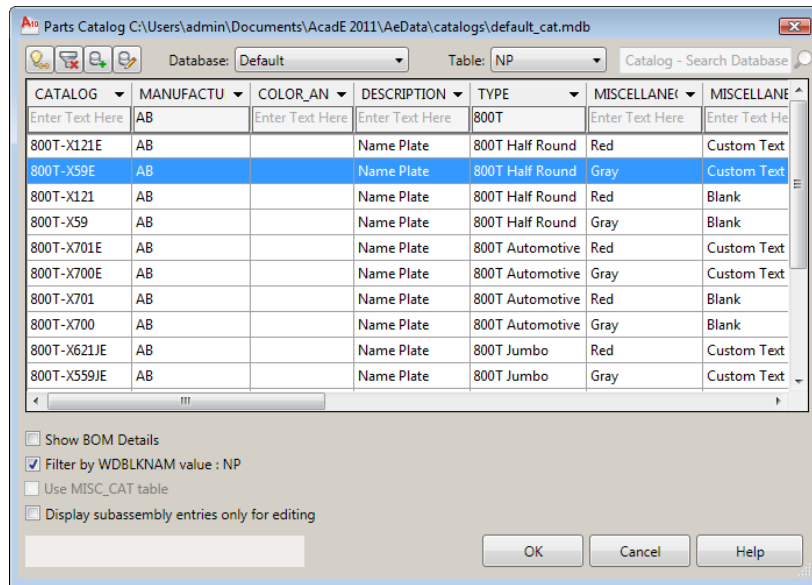

8 In the Nameplate dialog box, Choice A section, verify:

Manufacturer: AB

Catalog: 800T-X59E

Click OK.

9 Respond to the prompts as follows:

Select objects: *Select PB403A (2), right-click to place the nameplate*

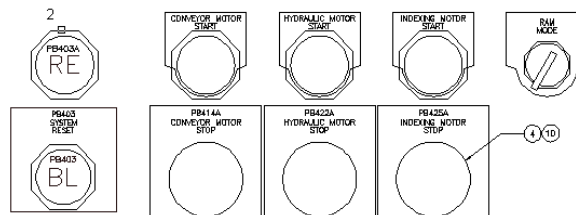

10 In the Panel Layout - Nameplate Insert/Edit dialog box, click OK.

The nameplate is inserted.

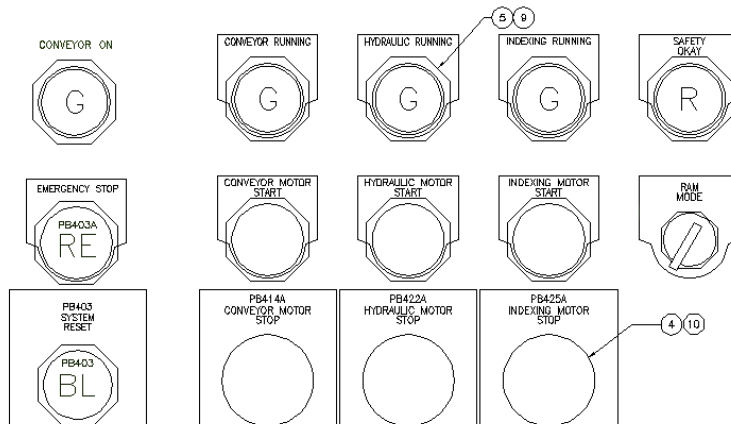

## Terminal Strip Editor

Terminal blocks connect devices that require quick disconnect or disassembly during product shipment. They can also be used to distribute power to other devices. The Terminal Strip Editor easily and quickly defines the locations for these connected devices during the system design process. Terminal strip editing is primarily used towards the end of the control system design cycle to expedite the labeling, numbering, and rearranging of terminals on a terminal strip.

### Copy and paste terminal properties

- 1 Open *AEGS09.dwg*.

The terminal strip to edit, "TB", is already placed on the drawing. Zoom in on terminal strip "TB" to see what the terminal strip currently looks like.

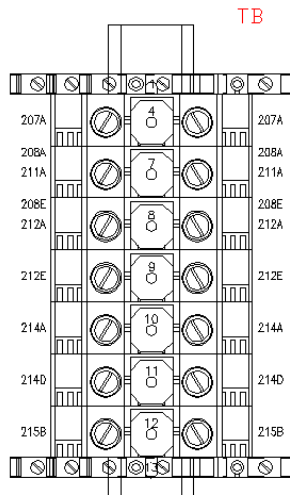

- 2 Click Panel tab ► Terminal Footprints panel ► Editor.
- 3 On the Terminal Strip Selection dialog box, select Terminal Strip “TB” and click Edit.
- 4 On the Terminal Strip Editor dialog box, Terminal Strip tab, select terminal 1 in the grid.

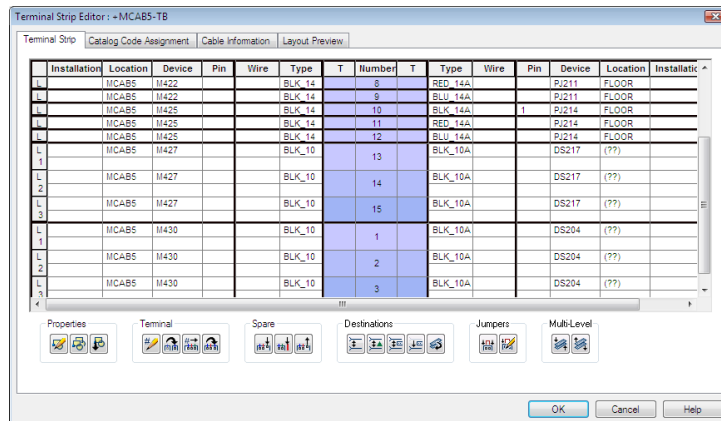

- 5 In the Terminal section, click the Move Terminal button. 
- 6 In the Move Terminal dialog box, click Pick Above. In the Terminal Strip Editor grid, select terminal 4.

---

**NOTE** You can also use the Move Up tool to move terminal 1 to the top of the grid.

---

Click Done.

- 7 Select terminal 4 in the grid.
- 8 In the Properties section, click the Copy Terminal Block Properties button.



Notice that when you click Copy Terminal Block Properties, terminals 5 and 6 also highlight. It is because terminals 4, 5, and 6 are associated. If you copy the properties from one of these terminals, you also copy the properties from the associated terminals. The Copy Terminal Block Properties tool then copies the properties from the terminals to one or many terminals within the same terminal strip.

- 9 Select terminal 7 and 10 in the grid by holding down the CTRL key while you select the terminals.
- 10 In the Properties section, click the Paste Terminal Block Properties button.



The properties you copied from terminal 4 are pasted to terminals 7 and 10. Notice that both terminals are now 3-tiered terminals with level 1 assigned for both.

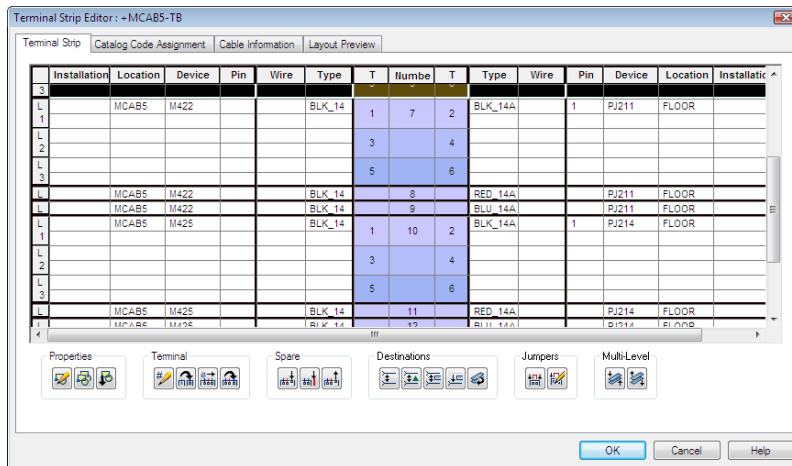

## Associate terminals

1 Select terminals 8 and 9 in the grid.

2 In the Multi-Level section, click the Associate Terminals button. 

3 On the Associate Terminals dialog box, select terminal 7, , (3) and click Associate.

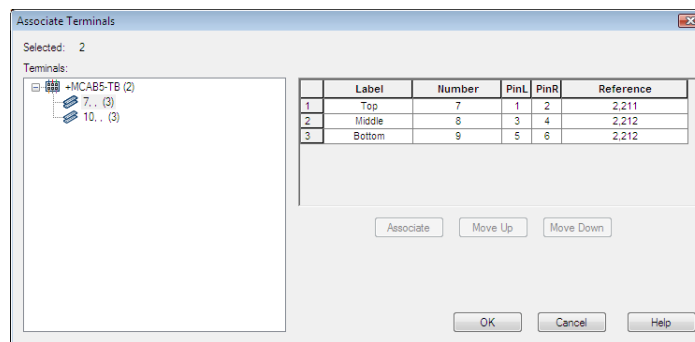

Click OK.

4 In the Spare section, click Delete Spare Terminals/Accessories to remove

the blank terminals resulting from the Associate. 

5 On the Terminal Strip Editor dialog box, select terminals 11 and 12 in the grid.

6 In the Multi-Level section, click the Associate Terminals button.



7 On the Associate Terminals dialog box, select terminal 10, , (3) and click Associate.

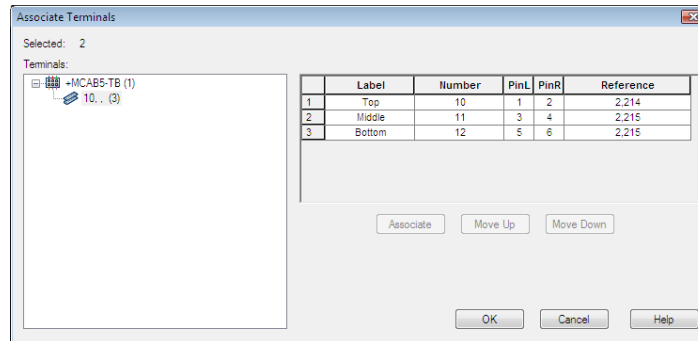

Click OK.

8 In the Spare section, click Delete Spare Terminals/Accessories to remove



the blank terminals resulting from the Associate.

## Insert spare terminals and accessories

1 Select terminal 7 in the grid.

2 In the Spare section, click the Insert Spare Terminal button.



3 On the Insert Spare Terminal dialog box, specify:

Number: SPARE

Quantity: 1

---

**NOTE** You can also assign catalog information for the spare terminal from the Insert Spare Terminal dialog box by clicking Catalog Lookup. If needed, you can then select the part from the Parts Catalog dialog box.

---

Click Insert Above.

Now you insert accessories (end barriers) into the terminal strip - one at the top and one at the bottom of the terminal strip.

- 4 Select terminal 1 in the grid.

- 5 In the Spare section, click the Insert Accessory button. 

- 6 On the Insert Accessory dialog box, specify:

Number: EB1

Quantity: 1

---

**NOTE** You can also assign catalog information for the accessory from the Insert Accessory dialog box by clicking Catalog Lookup. You can then select the part from the Parts Catalog dialog box.

---

Click Insert Above.

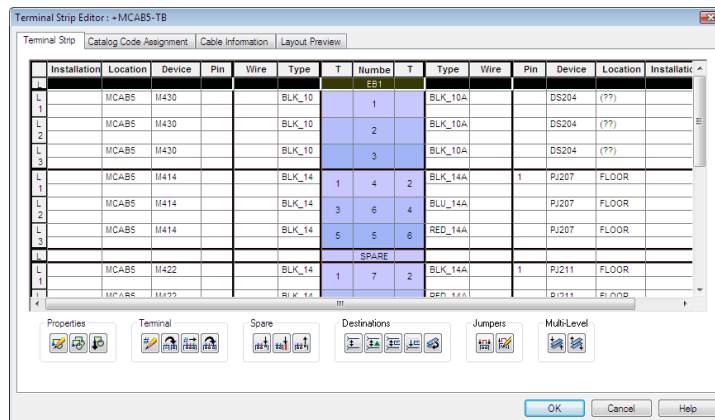

- 7 Select terminal 15 in the grid.

- 8 In the Spare section, click the Insert Accessory button. 

- 9 On the Insert Accessory dialog box, specify:

Number: EB2

Quantity: 1

Click Insert Below.

## Insert the terminal strip into the drawing

- 1 On the Terminal Strip Editor dialog box, click the Layout Preview tab.
- 2 Select Graphical Terminal Strip as the terminal type to insert into the drawing.
- 3 Enter 2.0 in Scale on Insert.
- 4 Click Rebuild.

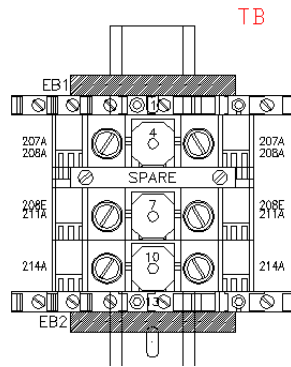

- 5 On the Terminal Strip Editor dialog box, click OK.
- 6 On the Terminal Strip Selection dialog box, click OK.

## Generating reports

### Generating reports - Introduction

Project Bill Of Material for all locations (6 records)					
TAGS	QTY	SUB	CATALOG	MFG	DESCRIPTION
CB322	5		EGH3015FFG	EATON	CIRCUIT BREAKER - E125 FRAME
CB324					3-POLE CIRCUIT BREAKER
CB326					15AMPS
CB328					TYPE E125H, FIXED THERMAL & MAGNETI
CB330					690VAC, 250VDC, 15AMPS
DS304	1		194E-A25-1753	AB	IEC LOAD SWITCH 3 POLE
					194E - LOAD SWITCH
					25AMPS
					ON-OFF BASE MOUNTED SWITCH (INCLUDE
					480VAC, 25AMPS
FU309	1		FRS-R-15	BUSSMANN	DUAL ELEMENT FUSE - CLASS RK5
					TIME DELAY, CURRENT LIMITING
					600VAC



Generate and work with reports.

Time required	30 minutes
Prerequisites:	Copy all files located in
<b>Windows XP</b>	<i>Documents and Settings\{username}\My Documents\Acade {version}\Aedata\Tutorial\Aegs\Generating reports</i> to <i>Documents and Settings\{username}\My Documents\Acade {version}\Aedata\Proj\Aegs</i>
<b>Windows Vista, Windows 7</b>	<i>Users\{username}\Documents\Acade {version}\Aedata\Tutorial\Aegs\Generating reports</i> to <i>Users\{username}\Documents\Acade {version}\Aedata\Proj\Aegs</i>

You learn to:

- Generate a report
- Insert a report on to a drawing
- Change the format of a report
- Export the report to a spreadsheet

## Generating Bill of Material reports

Using AutoCAD Electrical, you can perform a project-wide extract of all BOM data found on your project drawing set. The data is extracted from the project database, matched with standard entries in the catalog database, and then additional fields are pulled from the catalog files. You can:

- Format this data into various report configurations
- Output to report files
- Export to a spreadsheet or database program
- Place in an AutoCAD Electrical drawing

### Generate a Bill of Material (BOM) report

- 1 If AEGS is not the active project, in the Project Manager, right-click AEGS and select Activate.

- 2 In the Project Manager, double-click AEGS to expand the drawing list.
- 3 Open *AEGS11.dwg*.



- 4 Click Reports tab ► Schematic panel ► Reports.

- 5 In the Schematic Reports dialog box, select:

Report Name: Bill of Material

Bill of Material: Project

Verify that the following options are specified:

Include options: All the above

Display option: Normal Tallied Format

Installation Codes to extract: All

Location Codes to extract: All

Click OK.

- 6 In the Select Drawings to Process dialog box, select *AEGS03.DWG*, and click Process.
- 7 Verify that *AEGS03.DWG* displays in the Drawings to Process section of the dialog box and click OK.

The generated report displays in the Report Generator dialog box.

Project Bill Of Material for all locations (6records)					
TAGS	QTY	SUB	CATALOG	MFG	DESCRIPTION
CB322	5		EGH3015FFG	EATON	CIRCUIT BREAKER - E125 FRAME
CB324					3-POLE CIRCUIT BREAKER
CB326					15AMPS
CB328					TYPE E125H, FIXED THERMAL & MAGNETI
CB330					690VAC, 250VDC, 15AMPS
DS304	1		194E-025-1753	AB	IEC LOAD SWITCH 3 POLE
					194E - LOAD SWITCH
					25AMPS
					ON-OFF BASE MOUNTED SWITCH (INCLUDE
					480VAC, 25AMPS
FU309	1		FRS-R-15	BUSSMANN	DUAL ELEMENT FUSE - CLASS RK5
					TIME DELAY, CURRENT LIMITING
					600VAC

- 8 In the Report Generator dialog box, select:

Header: Time/Date

Header: Column Labels

Add blanks between entries

# Inserting Bill of Material tables into drawings

## Insert a BOM into the drawing in tabular format

- 1 With the BOM report displayed in the dialog box, click Put on Drawing.
- 2 In the Table Generation Setup dialog box, select:  
 Column Labels: Include column labels  
 Title: Include time/date  
 Column Width: Calculate automatically  
 Borders: All Borders  
 Click OK.

**NOTE** The extents of the BOM table are displayed in temporary graphics. Press Z to zoom down, or R to flip into real-time pan and zoom mode, if necessary.

- 3 The table outline moves with your cursor. Position the table, and then click to place the table. The BOM table is built where you placed it.

ITEM	QTY	DESCRIPTION	REMARKS
01	1	DESCRIPTION	DESCRIPTION
02	1	DESCRIPTION	DESCRIPTION
03	1	DESCRIPTION	DESCRIPTION
04	1	DESCRIPTION	DESCRIPTION
05	1	DESCRIPTION	DESCRIPTION
06	1	DESCRIPTION	DESCRIPTION
07	1	DESCRIPTION	DESCRIPTION
08	1	DESCRIPTION	DESCRIPTION
09	1	DESCRIPTION	DESCRIPTION
10	1	DESCRIPTION	DESCRIPTION
11	1	DESCRIPTION	DESCRIPTION
12	1	DESCRIPTION	DESCRIPTION
13	1	DESCRIPTION	DESCRIPTION
14	1	DESCRIPTION	DESCRIPTION
15	1	DESCRIPTION	DESCRIPTION
16	1	DESCRIPTION	DESCRIPTION
17	1	DESCRIPTION	DESCRIPTION
18	1	DESCRIPTION	DESCRIPTION
19	1	DESCRIPTION	DESCRIPTION
20	1	DESCRIPTION	DESCRIPTION
21	1	DESCRIPTION	DESCRIPTION
22	1	DESCRIPTION	DESCRIPTION
23	1	DESCRIPTION	DESCRIPTION
24	1	DESCRIPTION	DESCRIPTION
25	1	DESCRIPTION	DESCRIPTION
26	1	DESCRIPTION	DESCRIPTION
27	1	DESCRIPTION	DESCRIPTION
28	1	DESCRIPTION	DESCRIPTION
29	1	DESCRIPTION	DESCRIPTION
30	1	DESCRIPTION	DESCRIPTION
31	1	DESCRIPTION	DESCRIPTION
32	1	DESCRIPTION	DESCRIPTION
33	1	DESCRIPTION	DESCRIPTION
34	1	DESCRIPTION	DESCRIPTION
35	1	DESCRIPTION	DESCRIPTION
36	1	DESCRIPTION	DESCRIPTION
37	1	DESCRIPTION	DESCRIPTION
38	1	DESCRIPTION	DESCRIPTION
39	1	DESCRIPTION	DESCRIPTION
40	1	DESCRIPTION	DESCRIPTION
41	1	DESCRIPTION	DESCRIPTION
42	1	DESCRIPTION	DESCRIPTION
43	1	DESCRIPTION	DESCRIPTION
44	1	DESCRIPTION	DESCRIPTION
45	1	DESCRIPTION	DESCRIPTION
46	1	DESCRIPTION	DESCRIPTION
47	1	DESCRIPTION	DESCRIPTION
48	1	DESCRIPTION	DESCRIPTION
49	1	DESCRIPTION	DESCRIPTION
50	1	DESCRIPTION	DESCRIPTION

- 4 In the Report Generator, click Close.

## Changing format of Bill of Material report

Each AutoCAD Electrical report is customizable:

- Define which data fields are reported
- Define the order in which they appear
- Define the justification of any column
- Define the column labels

### Remove the TAGS columns from the BOM

- 1 Erase the table, or UNDO, and rerun the BOM extract for *AEGS03.DWG*.
- 2 In the Report Generator dialog box, click Change Report Format.  
In the Bill of Materials Data Fields to Report dialog box, Fields to report section, the fields that format the BOM are displayed.
- 3 Select TAGS in the Fields to report list.
- 4 Click <<Remove.

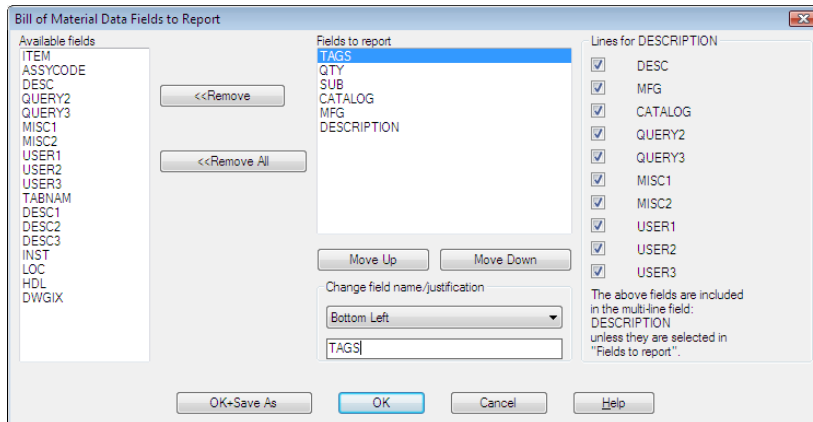

The TAGS field is moved out of Fields to report and into Available fields.

---

**NOTE** You can also select a field in the Available fields list to add it to the report. You can rearrange columns using the Move Up and Move Down buttons. Clicking Ok-Save As saves these settings to a file for later use.

---

- 5 Click OK.

---

**NOTE** This new format becomes the default the next time you extract a BOM report.

---

The BOM data in the Report Generator dialog box is reformatted and displayed.

- 6 Scroll down the report to verify that the component tags column is removed.
- 7 Insert the new version of the BOM table into the drawing.

## Exporting Bill of Material report to spreadsheet

You can move your BOM to a spreadsheet, database, or any other application that can read data in a comma-delimited or Microsoft®Access® format.

### Export the BOM to an Excel® spreadsheet

- 1 In the Report Generator dialog box, click Save to File.
- 2 In the Save Report to File dialog box, select Excel spreadsheet format (.xls) and click OK.
- 3 In the Select file for report dialog box, enter an output file name or click OK to accept the default name *BOM.xls*. Click Save.
- 4 In the Optional Script File dialog box, click Close - No Script.
- 5 In Excel, click File ► Open.
- 6 Browse to the location where you saved the spreadsheet. The default is *C:\Documents and Settings\{username}\My Documents* or *C:\Users\{username}\My Documents* on a Windows Vista or Windows 7 installation. Select the spreadsheet.
- 7 Click Open.

	A	B	C	D	E
1	QTY	SUB	CATALOG	MFG	DESC
2	5	1	EGH3015FFG	EATON	CIRCUIT BREAKER - E125 FRAME
3	1	1	194E-A25-1753	AB	IEC LOAD SWITCH 3 POLE
4	1	1	FRS-R-15	BUSSMANN	DUAL ELEMENT FUSE - CLASS RK5
5	2	1	FRS-R-5	BUSSMANN	DUAL ELEMENT FUSE - CLASS RK5
6	10	1	DN-T10	AUTOMATIONDIRECT	TERMINAL BLOCK
7	1	1	3S40F	SQD	1PH TRANSFORMER, CLASS 7400

Your BOM data displays in spreadsheet format. You can slide the column borders to expose the full column of text for each field. The first six columns

of the spreadsheet are shown in the previous image. The first column is the tallied quantity, followed by subassembly quantity, catalog number, and manufacturer code. The remaining fields are the fields extracted from the *mfg/cat* combo query on the external catalog look-up file.

## Connector diagrams

### Connector diagrams - Introduction

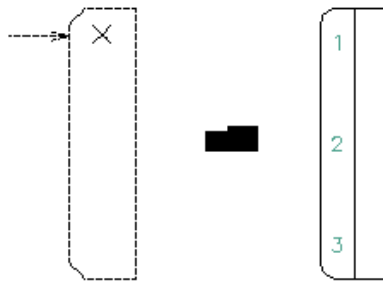

Insert, modify, and wire connectors.

Time required 45 minutes

Prerequisites: Copy all files located in

**Windows XP** *Documents and Settings\{username}\My Documents\Acade {version}\Aedata\Tutorial\Aegs\Connector diagrams*  
to  
*Documents and Settings\{username}\My Documents\Acade {version}\Aedata\Proj\Aegs*

**Windows Vista, Windows 7** *Users\{username}\Documents\Acade {version}\Aedata\Tutorial\Aegs\Connector diagrams*  
to  
*Users\{username}\Documents\Acade {version}\Aedata\Proj\Aegs*

You learn to:

- Understand connectors
- Insert a connector

- Wire connectors
- Insert in-line connectors
- Stretch a connector
- Add a connector pin
- Move a connector pin
- Add connector descriptors

## About connector diagrams

The connector wiring tools help you more easily create and work with point-to-point style wiring schematics (as opposed to ladder-style schematics). Although some of these tools are useful for ladder-style schematics, they are tuned to work well with drawings that are heavy on point-to-point connector diagrams. Instead of creating and maintaining a large library of schematic connector symbols, each symbol is generated parametrically. It is generated on the fly, per user input and at user-defined orientation. A connector toolbar contains tools for creating and editing connectors.

## Inserting connectors

The Insert Connector tool generates a connector symbol from user-defined parameters. The symbol is created on the fly and inserted as a block insert into your active drawing file. Since they are created on an as needed basis, it eliminates the need for you to create and maintain a library of connector symbols.

### Change drawing properties

- 1 If AEGS is not the active project, in the Project Manager, right-click AEGS and select Activate.
- 2 In the Project Manager, double-click AEGS to expand the drawing list.
- 3 Open *AEGS10.dwg*.

- 4 Click Schematic tab ► Other Tools panel ► Drawing Properties

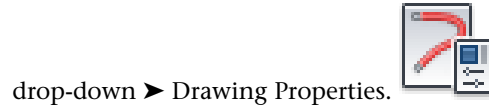

drop-down ► Drawing Properties.

- 5 On the Drawing Properties ► Components dialog box, select Sequential.
- 6 On the Drawing Properties ► Wire Numbers dialog box, New Wire Number Placement section, select In-Line.
- 7 Click OK.

## Add connectors to the drawing

- 1 Click Schematic tab ► Insert Components panel ► Insert Connector



drop-down ► Insert Connector.

- 2 On the Insert Connector dialog box, specify:

Pin Spacing: 1.0

Pin Count: 15

Fixed Spacing

Pin List: 1

Insert All

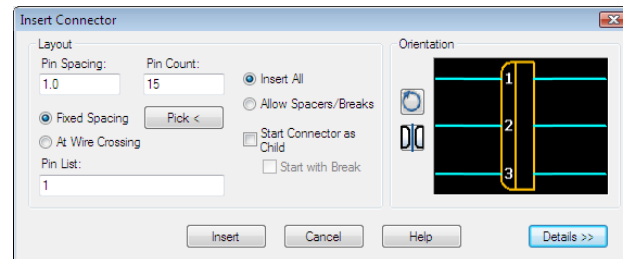

- 3 Click the Flip button to flip the connector about its long axis. The preview looks like the following image.



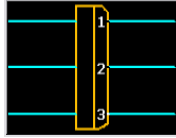

**4** Click Insert.

A preview outline of the connector displays for placement on the drawing. It shows rounded corners for the plug side of the connector. An “x” indicates the insertion point of the connector. An arrow indicates the plug side wire connection direction for plug/receptacle or plug-only connector inserts or shows the wire connection direction for a receptacle-only connector insert.

---

**NOTE** Before committing the connector outline to the drawing, press TAB to flip the connector through four different orientations. Or, press the V key to switch between vertical and horizontal orientations.

---

**5** Respond to the prompts as follows:

Specify insertion point or [Z=zoom, P=pan, X=wire crossing, V=horizontal/vertical, TAB=flip]:

*Select to place the connector in the middle of the right-hand border of Black Box 1*

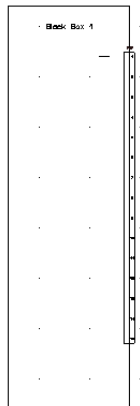

The connector was automatically assigned a component tag of PJ1.

- 6 Click Schematic tab ► Insert Components panel ► Insert Connector



- 7 On the Insert Connector dialog box, specify:

Pin Spacing: 0.75

Pin Count: 4

Fixed Spacing

Pin List: A

Insert All

- 8 Click the Flip button to flip the connector. 

The preview looks like the following image.

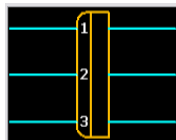

- 9 Click Insert.

- 10 Respond to the prompts as follows:

Specify insertion point or [Z=zoom, P=pan, X=wire crossing,  
V=horizontal/vertical, TAB=flip]:

*Select to place the connector in the middle of the left-hand border of Black Box*

2

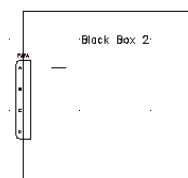

The connector was automatically assigned a component tag of PJ2.

- 11 Repeat steps 6 - 10 to place connectors on Black Box 3 and Black Box 4.  
The connectors are assigned tags PJ3 and PJ4 respectively.

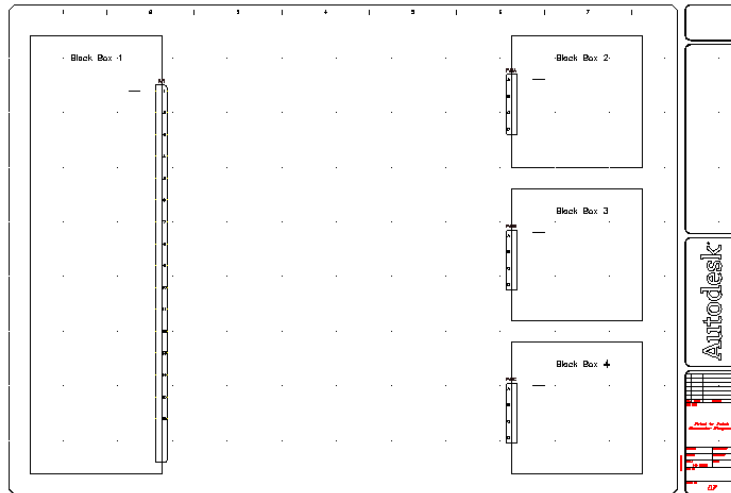

## Wiring connectors

Black Box 1 is associated to a larger component such as a power box. Black Box 2 - Black Box 4 are smaller components that are part of the power box. The components must be wired together. The easiest way to do it is to use the Insert Wire and Multiple Wire Bus tools.

### Wire the connectors together

- 1 Click Schematic tab ► Insert Wires/Wire Numbers panel ► Insert Wires

drop-down ► Wire.



- 2 Respond to the prompts as follows:

Specify wire start or [wireType/X=show connections]:

*Click PJ1 at pin 1 on Black Box 1*

Specify wire end or [Continue]: *Click PJ2 at pin A on Black Box 2*

- 3 Repeat to connect PJ1 (Pin 2) to PJ3 (Pin A) and PJ1 (Pin 3) to PJ4 (Pin A). Right-click to exit the command.

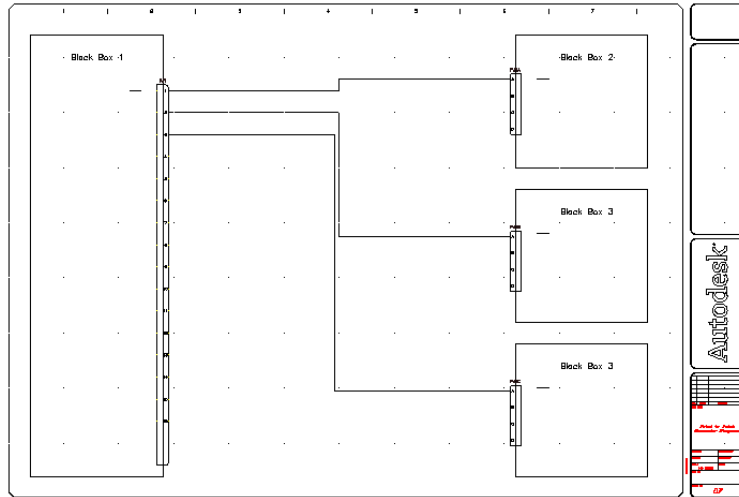

Notice that the Insert Wire tool drew the wire between the connectors while avoiding any existing geometry on the screen.

- 4 Click Schematic tab ► Insert Wires/Wire Numbers panel ► Multiple Bus.



- 5 On the Multiple Wire Bus dialog box, specify:

Horizontal Spacing: 0.75

Vertical Spacing: 0.50

Starting at: Component (Multiple Wires)

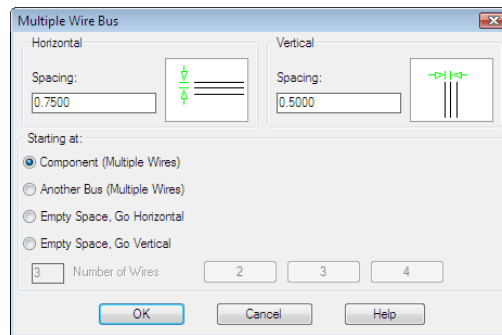

6 Click OK.

7 Respond to the prompts as follows:

Window select starting wire connection points

*Select pins 5-7 on Black Box 1 (1) and right-click*

to (T= wiretype):

*Drag the wires to the right past the three wires you inserted,*

to Point (Continue/Flip):

*Drag up the wires towards PJ2 on Black Box 2, enter C and press ENTER (to continue and lock the drag)*

to (Continue/Flip):

*Drag the wires to the right and connect to pins B-D on PJ2 (2)*

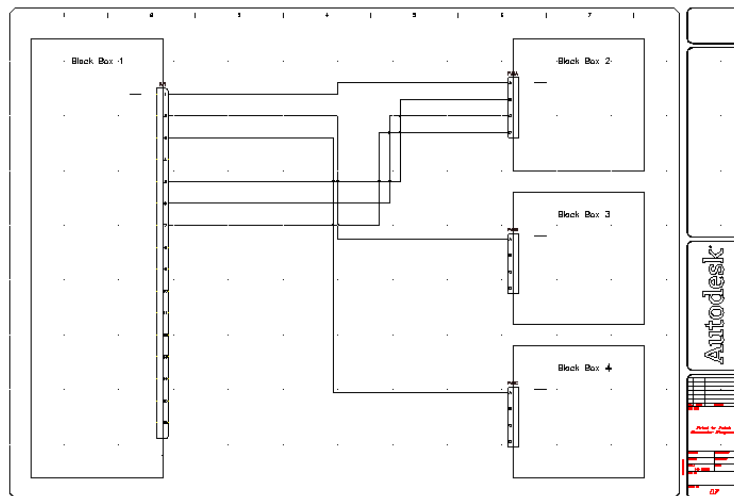

8 Click Schematic tab ► Insert Wires/Wire Numbers panel ► Multiple Bus.



9 On the Multiple Wire Bus dialog box, click OK to use the previous settings.

10 Respond to the prompts as follows:

Window select starting wire connection points:

*Select pins 9-11 on Black Box 1 and right-click*

to (T= wiretype):

*Drag the wires to the right,*

to Point (Continue/Flip):

*Drag up the wires towards PJ3 on Black Box 3, enter C, and press ENTER (to continue and lock the drag)*

to (Continue/Flip):

*Drag the wires to the right and connect to pins B-D on PJ3*

- 11** Click Schematic tab ► Insert Wires/Wire Numbers panel ► Multiple Bus.



- 12** On the Multiple Wire Bus dialog box, click OK to use the previous settings.

- 13** Respond to the prompts as follows:

Window select starting wire connection points:

*Select pins 13-15 on Black Box 1 and press ENTER*

to (T= wiretype):

*Drag the wires to the right,*

to Point (Continue/Flip):

*Drag the wires down towards PJ4 on Black Box 4, press C, and press ENTER (to continue and lock the drag)*

to (Continue/Flip):

*Drag the wires to the right and connect to pins B-D on PJ4*

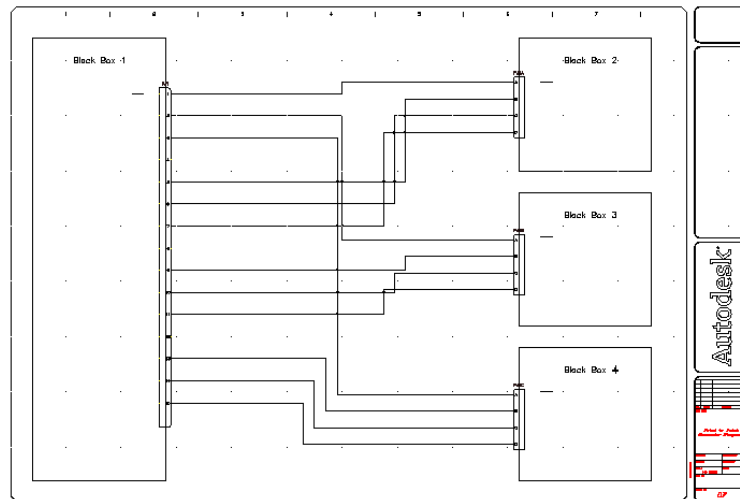

## Grouping wires

Now that you wired the connectors together, you insert in-line connectors to group the wires.

### Insert in-line connectors

- 1 Click Schematic tab ► Insert Components panel ► Insert Connector

drop-down ► Insert Connector. 

- 2 On the Insert Connector dialog box, specify:

Pin Spacing: 1.0

Pin Count: 3

At Wire Crossing

Pin List: 1

Insert All

- 3 Click Details.
- 4 On the Type section, clear the Add Divider Line box.

- 5 On the Display section, set Plug to Right and Pins to Both Sides.
- 6 On the Size section, set the Plug to 0.325.

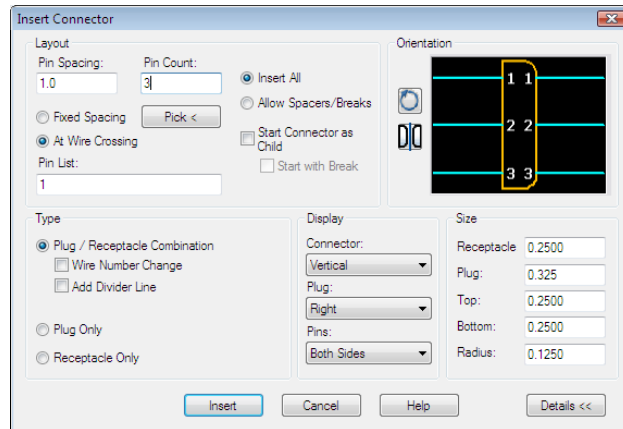

- 7 Click Insert.
- 8 Respond to the prompts as follows:  
Specify insertion point or [Z=zoom, P=pan, X=wire crossing, V=horizontal/vertical, TAB=flip]:  
*Select to place the connector on the wires connected to P11, Pins 1-3*

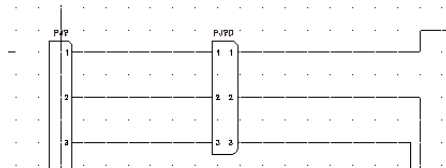

- 9 Click Schematic tab ► Insert Components panel ► Insert Connector

drop-down ► Insert Connector. 

- 10 On the Insert Connector dialog box, specify:  
Pin Spacing: 1.0  
Pin Count: 9  
At Wire Crossing  
Pin List: 1



### Allow Spacers/Breaks

**11** Click Insert.

**12** Respond to the prompts as follows:

Specify insertion point or [Z=zoom, P=pan, X=wire crossing, V=horizontal/vertical, TAB=flip]:

*Select to place the connector starting on the line at PJ1, Pin 5*

Notice how the connector expands when you cross the wires.

**13** On the Custom Pin Spaces/Breaks dialog box, click Insert Next Connection.

The dialog box displays which connector pin has been inserted so far. Keep clicking Insert Next Connection until you place six of the nine connections.

**14** When the Custom Pin Spaces/Breaks dialog box says “Inserted So Far: 6 of 9,” click Break Symbol Now.

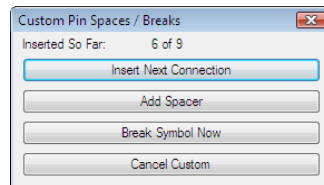

**15** Respond to the prompts as follows:

Specify insertion point or [Z=zoom, P=pan, X=wire crossing, V=horizontal/vertical, TAB=flip]:

*Select to place the connector starting on the line at PJ1, Pin 13*

**16** On the Connector Layout dialog box, select Insert All.

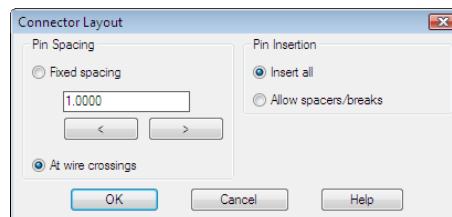

**17** Click OK.

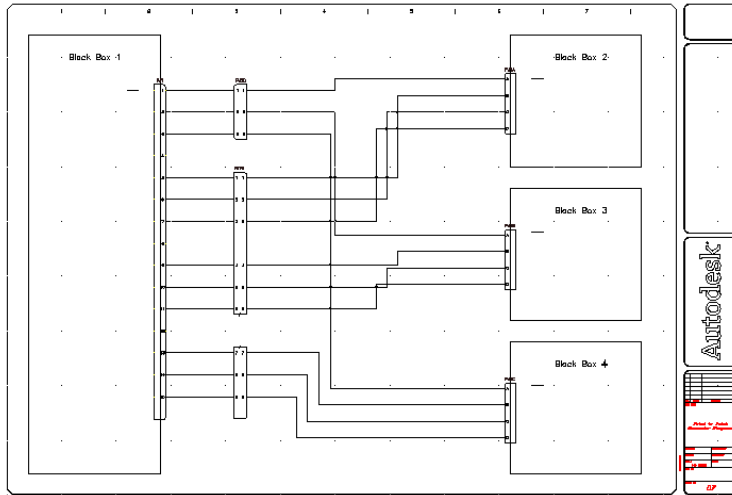

**NOTE** Another method is to insert the entire connector and then use the Split Connector tool to break the existing connector.

- 18** Click Schematic tab ► Insert Components panel ► Dashed Link Line



drop-down ► Link Components with Dashed Line.

- 19** Respond to the prompts as follows:

Component to link from: *Select the bottom portion of PJ6 (1)*

component to link to: *Select the top portion of PJ6 (2), right-click*

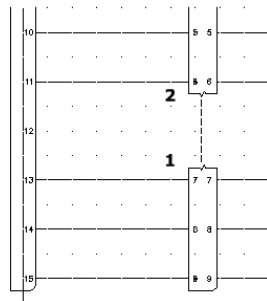

## Modifying connectors

The Insert Connector toolbar has tools for modifying connectors and connector pins. You can also add, remove, or move the pins found inside of the connector.

### Stretch existing connectors

- 1 Click Schematic tab ► Edit Components panel ► Modify Connectors



drop-down ► Stretch Connector.

- 2 Respond to the prompts as follows:

Specify which end of connector to stretch: *Select the bottom of PJ1*

Specify second point of displacement:

*Pull the connector down towards the bottom of Black Box 1*

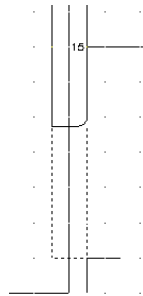

- 3 Repeat for PJ6, pulling the bottom of the connector down so that it is even with PJ1.

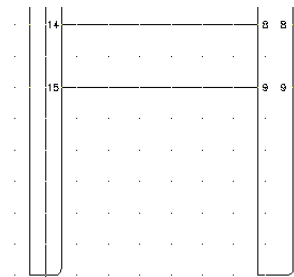

## Add connector pins

- 1 Click Schematic tab ► Edit Components panel ► Modify Connectors

drop-down ► Add Connector Pins. 

- 2 Respond to the prompts as follows:

Select connector: *Select PJ1*

Specify where to insert new pin or [Reset]<16>:

*Select 4 spaces down from pin 15 on PJ1, right-click, and select Enter*

The next available pin number (16) inserts at the selected point.

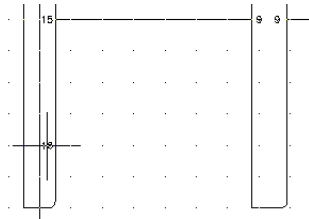

- 3 Click Schematic tab ► Edit Components panel ► Modify Connectors

drop-down ► Add Connector Pins. 

- 4 Respond to the prompts as follows:

Select connector: *Select PJ6*

Specify where to insert new pin or [Reset]<10>:

*Select the new pin 16 on PJ1 to insert pin 10 in-line with it, right-click and select Enter*

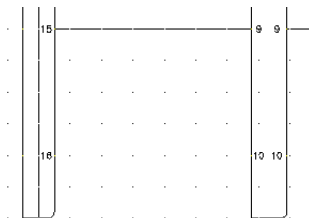

---

**NOTE** You can delete pins using the Delete Connector Pins tool. Select the pin you want to delete and it is automatically removed from the connector.

---

## Modify connector pins

- 1 Click Schematic tab ► Edit Components panel ► Modify Connectors



drop-down ► Move Connector Pins.

- 2 Respond to the prompts as follows:

Select connector pin to move: *Select pin 16 on PJ1*

Specify new location for pin 16: *Select 2 spaces up on PJ1*

Select connector pin to move: *Select pin 10 on PJ6*

Specify new location for pin 10:

*Select pin 16 on PJ1 to move pin 10 in-line with it, right-click*

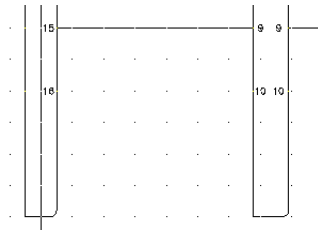

- 3 Click Schematic tab ► Edit Components panel ► Modify Connectors



drop-down ► Swap Connector Pins.

- 4 Respond to the prompts as follows:

Select connector pin: *Select pin 16 on PJ1*

Select connector pin: swap with: *Select pin 12 on PJ1, right-click*

- 5 Click Schematic tab ► Edit Components panel ► Modify Connectors



drop-down ► Reverse Connector.

6 Respond to the prompts as follows:

Select connector to Reverse: *Select the top in-line connector, right-click*

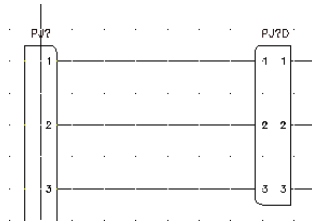

7 Click Schematic tab ► Insert Components panel ► Insert Connector



drop-down ► Insert Connector.

8 On the Insert Connector dialog box, specify:

Pin Spacing: 1.0

Pin Count: 2

Fixed Spacing

Pin List: 1

Insert All

9 Click Details.

10 On the Type section, select Add Divider Line.

11 On the Display section, set Pins to Plug Side.

12 Click Insert.

13 Respond to the prompts as follows:

Specify insertion point or [Z=zoom, P=pan, X=wire crossing,  
V=horizontal/vertical, TAB=flip]:

*Select to place the connector on the top of Black Box 1*

14 Click Schematic tab ► Edit Components panel ► Modify Connectors



drop-down ► Rotate Connector.

15 Respond to the prompts as follows:

Select connector to Rotate or [Hold]:

Select the new connector, right-click, and select Enter

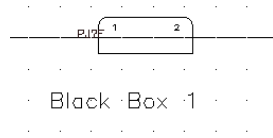

## Adding wire numbers

Wire numbers are blocks or attributes inserted on a line wire entity. AutoCAD® Electrical assigns each wire number type to its own layer. You can assign a different color to each of these layers so you can easily tell them apart. The wire number placement is set to in-line as defined on the Drawing Properties ► Wire Numbers dialog box.

### Insert wire numbers

- 1 Click Schematic tab ► Insert Wires/Wire Numbers panel ► Insert Wire

Numbers drop-down ► Wire Numbers. 

- 2 On the Wire Tagging dialog box, specify:

Wire Tag Mode: Sequential

Start: 100

- 3 Click Drawing-Wide.

The wire numbers are automatically inserted into the drawing starting with number 100.

- 4 Click Schematic tab ► Edit Wires/Wire Numbers panel ► Move Wire

Number. 

- 5 Respond to the prompts as follows:

Specify new Wire Number location (select on wire):

Select each wire closest to Black Box 1, right-click

---

**NOTE** You can align the wire numbers using the Align tool.

---

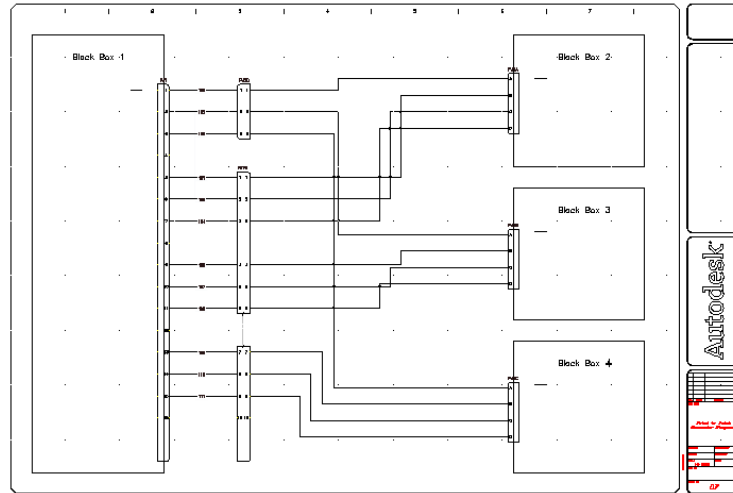

## Adding connector descriptors

AutoCAD Electrical supports two lines of description text on each connector: one for the plug and one for the receptacle side of the connector.

### Add descriptions

- 1 Right-click connector PJ1 and select Edit Component.
- 2 On the Insert/Edit Component dialog box, Pins section, click List.
- 3 On the Connector Pin Numbers In Use dialog box, connector pin grid, click in the Description column for Pin 1.
- 4 On the Pin Descriptions section, enter *POWER B2* for the Receptacle.
- 5 On the connector pin grid, click in the Description column for Pin 2.
- 6 On the Pin Descriptions section, enter *POWER B3* for the Receptacle.
- 7 On the connector pin grid, click in the Description column for Pin 3.
- 8 On the Pin Descriptions section, enter *POWER B4* for the Receptacle.



Sheet Reference	Plug	Description	Rece...	Description	Wire Numbers
01. ?	1		1	POWER B2	100.
01. ?	2		2	POWER B3	102.
01. ?	3		3	POWER B4	105.

- 9 Click OK.
- 10 On the Insert/Edit Component dialog box, click OK.
- 11 Repeat to add the description POWER IN for Pins A on Black Box 2, Black Box 3 and Black Box 4.

Your finished point-to-point diagram looks like the following image.

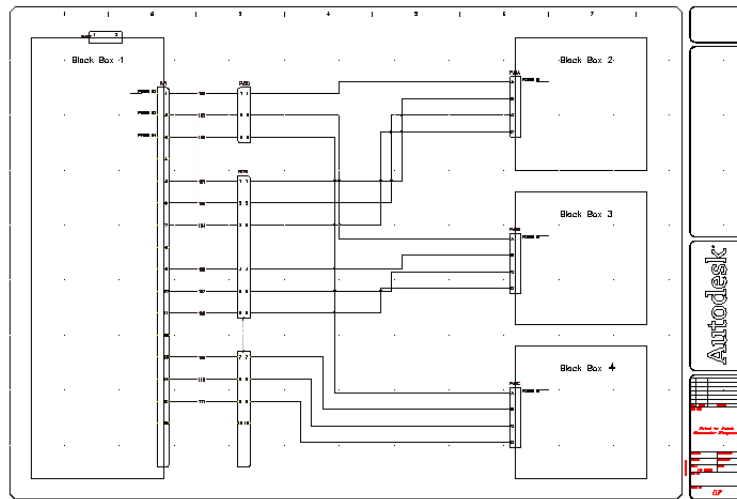

# P&ID and Hydraulic diagrams

## P&ID and Hydraulic diagrams - Introduction

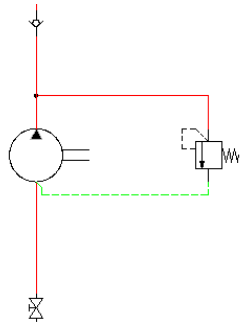

Create Piping & Instrumentation (P&ID) and Hydraulic drawings. The same workflow can be applied for Pneumatics. Once your drawing is created, use the standard tools in the AutoCAD Electrical software to modify your drawing.

Time required 65 minutes

Prerequisites: Copy all files located in

**Windows XP** *Documents and Settings\{username}\My Documents\Acade {version}\Aedata\Tutorial\Aegs\P&ID*  
to  
*Documents and Settings\{username}\My Documents\Acade {version}\Aedata\Proj\Aegs*

**Windows Vista, Windows 7** *Users\{username}\Documents\Acade {version}\Aedata\Tutorial\Aegs\P&ID*  
to  
*Users\{username}\Documents\Acade {version}\Aedata\Proj\Aegs*

You learn to:

- Set up hydraulic and P&ID drawings
- Insert hydraulic and P&ID symbols
- Create pipes

## Setting Up Hydraulic Drawings

Use the Project Manager to manage your hydraulic drawings. From here, you can create a drawing and modify any drawing properties.

### Create a new drawing

- 1 Click Project tab ► Project Tools panel ► Manager. 
- 2 If AEGS is not the active project, activate the AEGS project.  
If AEGS is in the list of open projects:
  - Select AEGS and right-click.
  - Click Activate.If AEGS is not in the list of open projects:
  - Select the project list drop-down.
  - Click Open Project.
  - On the Select Project File dialog box, navigate to and select the *AEGS.WDP* file.
  - Click Open.
- 3 In the Project Manager, right-click the project name, and select Properties.
- 4 In the Project Properties ► Project Settings dialog box, click Default to switch on all paths for pneumatic, hydraulic, and P&ID schematic libraries.
- 5 Click OK.



- 6 In the Project Manager, click the New Drawing tool.
- 7 In the Create New Drawing dialog box, specify:  
Name: AEGS12  
Template: *Mouse over the edit box to verify ACAD\_Electrical.dwt is specified*

If *ACAD\_Electrical.dwt* is not specified, click Browse. Select it from the list of available templates.

Description 1: Hydraulic Example

Click OK.

---

**NOTE** If you want to set the component, wire number, cross-reference, style, and drawing format settings, click OK-Properties to proceed to Drawing Properties dialog box.

---

- 8 Enter DSETTINGS at the command prompt.
- 9 In the Drafting Settings dialog box ► Snap and Grid tab, turn on Snap and Grid and set the size of both to 0.125.
- 10 Click OK.



- 11 Click Schematic tab ► Other Tools panel ► Drawing Properties.
- 12 In the Drawing Properties dialog box ► Drawing Format tab, Scale section, make sure that the feature scale multiplier is set to 1.0 inch.
- 13 Click OK.

---

**NOTE** For metric unit, the following settings are recommended so that the wire connection points are placed on the grids for easier drafting. Grid and Snap Size = 2.5 mm; Feature scale multiplier = 20 (scale factor = 20).

---

## Inserting Hydraulic Schematic Symbols

The hydraulic symbol library in AutoCAD Electrical includes filters, valves, cylinders, pressure switches, motors, pumps, meters, restrictors, quick disconnects, flow arrows and more. The hydraulic symbol library consists of all the hydraulic symbols. It is found at *\Documents and Settings\All Users\Documents\Autodesk\Acade {version}\Libs\hyd\_iso125* or *\Users\Public\Documents\Autodesk\Acade {version}\Libs\hyd\_iso125* on a Windows Vista or Windows 7 installation.

## Insert hydraulic symbols

- 1 Click Schematic tab ► Insert Components panel ►  ► Insert



Hydraulic Components.

---

**NOTE** By default, an expanded panel closes automatically when you click another panel. To keep a panel expanded, click the push pin icon in the bottom-left corner of the expanded panel.

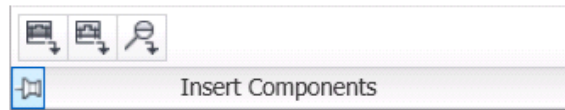

- 2 In the Insert Component: Hydraulic Symbol dialog box, select the check box for Vertical.
- 3 In the Insert Component: Hydraulic Symbol dialog box, click the General



Valves icon.

- 4 In the Hydraulic: General Valves dialog box, click Shut Off Valve Open.



- 5 Respond to the prompts as follows:

Specify insertion point:

*Select to place the valve in the upper left corner of your drawing*

- 6 In the Insert/Edit Component dialog box, specify:

Component Tag: VAL2

Click OK.

- 7 Repeat steps 1 - 3.

- 8 In the Hydraulic: General Valves dialog box, click Checkvalve Flow Left.



9 Respond to the prompts as follows:

Specify insertion point:

Select to place the check valve below the shut off valve

10 In the Insert/Edit Component dialog box, click OK.

11 Click Schematic tab ► Insert Components panel ►  ► Insert



Hydraulic Components.

12 In the Insert Component: Hydraulic Symbol dialog box, click Motors &

Pumps. 

13 In the Hydraulic: Motors and Pumps dialog box, click Fixed Displacement.



14 In the Hydraulic: Fixed Displacement dialog box, click Uni-Directional

Pump. 

15 Respond to the prompts as follows:

Specify insertion point: Select to place the pump below the check valve

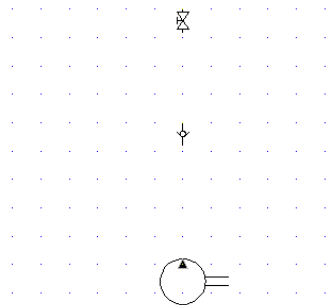

16 In the Insert/Edit Component dialog box, specify:

Description: Line 1: Hydraulic Oil Pump

Click OK.

- 17 Insert another Shut Off Valve Open below the Hydraulic Oil Pump.

- 18 Click Schematic tab ► Insert Components panel ►  ► Insert



Hydraulic Components.

- 19 In the Insert Component: Hydraulic Symbol dialog box, click Filters.



- 20 In the Hydraulic: Filters dialog box, click Filter. 

- 21 Respond to the prompts as follows:

Specify insertion point: *Select to place the filter below the shut off valve*

- 22 In the Insert/Edit Component dialog box, specify:

Component Tag: FI2

Description: Line 1: Filter

Click OK.

- 23 Click Schematic tab ► Insert Components panel ►  ► Insert



Hydraulic Components.

- 24 In the Insert Component: Hydraulic Symbol dialog box, click



Miscellaneous.

- 25 In the Hydraulic: Miscellaneous dialog box, click Reservoir. 

- 26 Respond to the prompts as follows:

Specify insertion point: *Select to place the reservoir below the filter*

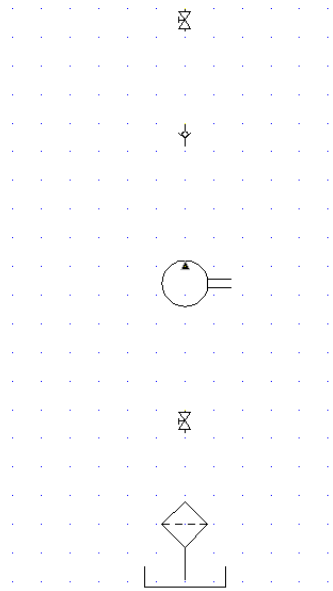

27 In the Insert/Edit Component dialog box, click OK.

## Creating Pipes

In AutoCAD Electrical, different types of wires represent the type of running pipes that allow water or oil flows from one instrument to another. Start by setting up the type of wires for pipe runs.

### Insert wires as pipes

- 1 Click Schematic tab ► Edit Wires/Wire Numbers panel ► Create/Edit



Wire Type.

- 2 In the Create/Edit Wire Type dialog box, specify:

Wire Color: RED

Size: 20

The Layer Name is automatically created. The name RED\_20 is assigned to the wire layer you are creating.



- 3 Click Color.
- 4 In the Select Color dialog box, select red and click OK.
- 5 Click Linetype.
- 6 In the Select Linetype dialog box, select Continuous and click OK.
- 7 In the Create/Edit Wire Type dialog box, specify:

Wire Color: GREEN

Size: 10

Color: Green

Linetype: Hidden2

---

**NOTE** If HIDDEN2 is not available, click Load. Select it from the list of line types on the Load or Reload Linetypes dialog box.

---

- 8 Select RED\_20 in the grid and click Mark Selected as Default.

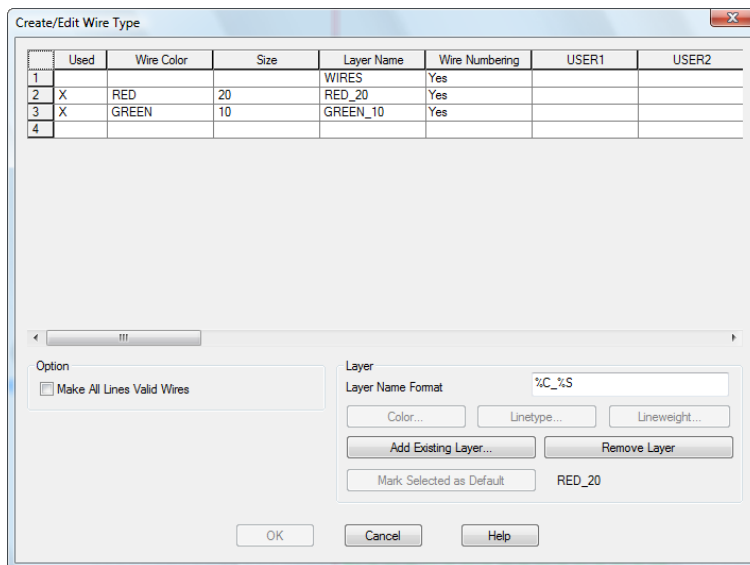

- 9 Click OK.

- 10 Click Schematic tab ► Insert Wires/Wire Numbers panel ► Wire.



**11** Respond to the prompts as follows:

Specify wire start or [wireType/X=show connections]:

*Enter X and press ENTER*

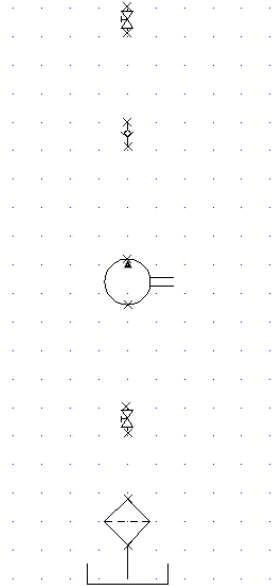

Specify wire start or [wireType/X=show connections]:

*Select the bottom of the shut off valve*

Specify wire end or [Scoot/T=wiretype, X=show connections]:

*Select the top of the check valve*

**12** Continue inserting wires connecting the components together. Right-click to exit the command.

Your drawing should look like the following:

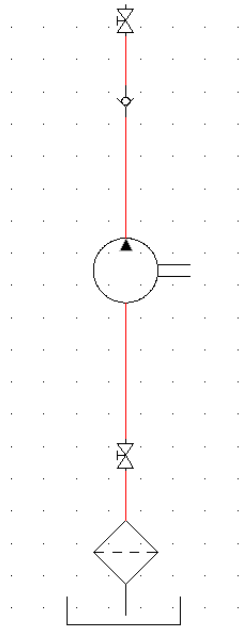

---

**NOTE** You can also insert the vertical or horizontal pipes first and then insert the components onto the pipe, one at a time.

---

- 13 Click Schematic tab ► Insert Components panel ►  ► Insert



Hydraulic Components.

- 14 In the Insert Component: Hydraulic Symbol dialog box, select the check box for Vertical.

- 15 In the Insert Component: Hydraulic Symbol dialog box, click Pressure



Relief Valves.

- 16 In the Hydraulic: Pressure Relief Valves dialog box, click N.C. Pressure



Relief Valve with Preset -1.

**17** Respond to the prompts as follows:

Specify insertion point: *Select to place the valve to the right of the pump*

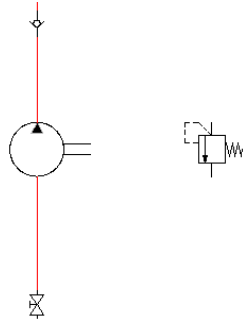

**18** In the Insert/Edit Component dialog box, specify:

Component Tag: VAL4

Description: Line 1: Pressure Relief

Click OK.

**19** Click Schematic tab ► Insert Wires/Wire Numbers panel ► Wire.



**20** Respond to the prompts as follows:

Specify wire start or [wireType/X=show connections]:

*Enter X, press ENTER*

Specify wire start or [wireType/X=show connections]:

*Press SHIFT + right-click and select Midpoint from the menu, then select the midpoint on the pipe between the pump and the shut off valve above it*

Specify wire end or [V=start Vertical/H =start Horizontal/Continue):

*Drag the pipe to the right so that it is directly above the pressure relief valve. Drag the pipe down and click the top connection point on the pressure relief valve*

You now insert a pipe that connects the end of the valve back to the pump.

Specify wire start or [wireType/X=show connections]:

*Enter T, press ENTER*

Select the wire layer GREEN\_10. Click OK.

---

**TIP** Make sure that Snap is turned off and that the Wire Layer is set to GREEN\_10.

---

*Select the bottom connection point on the pump*

Specify wire end or [V=start Vertical/H =start Horizontal/Continue):

*Drag the pipe down and to the right, click the connection point at the bottom of the pressure relief valve, right-click*

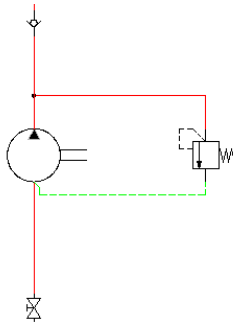

## Completing the Hydraulic Drawing

The rest of the hydraulic drawing consists of inserting a Pressure Gauge and Check Valve at the left side of the pump and then inserting devices (Cylinder; Restrictors; Filter; Check valve and 2-ways valve) along the top of the drawing.

---

**NOTE** During insertion, clear the Vertical option in the Insert Component: Hydraulic Symbols dialog box.

---

### Insert components

1 Click Schematic tab ► Insert Components panel ►  ► Insert

Hydraulic Components. 

- 2 In the Insert Component: Hydraulic Symbol dialog box, click Meters.



- 3 In the Hydraulic: Meters dialog box, click Pressure Gauge.



- 4 Respond to the prompts as follows:

Specify insertion point:

*Select to place the pressure gauge to the far left (and slightly above) of the pump*

- 5 In the Insert/Edit Component dialog box, specify:

Component Tag: MTR1

Description: Line 1: Pressure Gauge

Click OK.

- 6 Click Schematic tab ► Insert Components panel ►  ► Insert



Hydraulic Components.

- 7 In the Insert Component: Hydraulic Symbol dialog box, deselect the Vertical check box.

- 8 In the Insert Component: Hydraulic Symbol dialog box, click General



Valves.

- 9 In the Hydraulic: General Valves dialog box, click Shut Off Valve Open.



- 10 Respond to the prompts as follows:

Specify insertion point:

*Select to place the valve to the right of the pressure gauge*

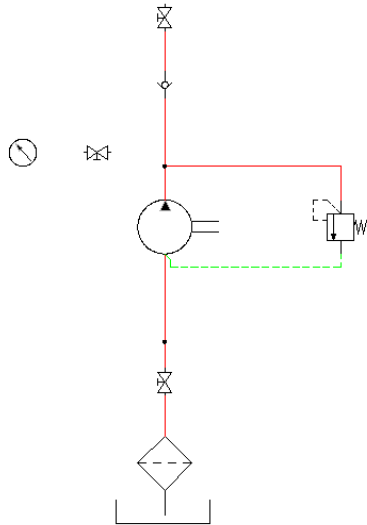

- 11 In the Insert/Edit Component dialog box, click OK.
- 12 Set the wire layer to RED\_20.

- 13 Click Schematic tab ► Insert Wires/Wire Numbers panel ► Wire.



- 14 Respond to the prompts as follows:

Specify wire start or [wireType/X=show connections]:

*Select the right connection point on the pressure gauge*

Specify wire end or [Continue]:

*Drag the pipe to the right and click the left connection point on the valve*

Specify wire start or [Scoot/wireType/X=show connections]:

*Select the right connection point on the valve*

Specify wire end or [Continue]:

*Drag the pipe to the right and click the vertical pipe, right-click*

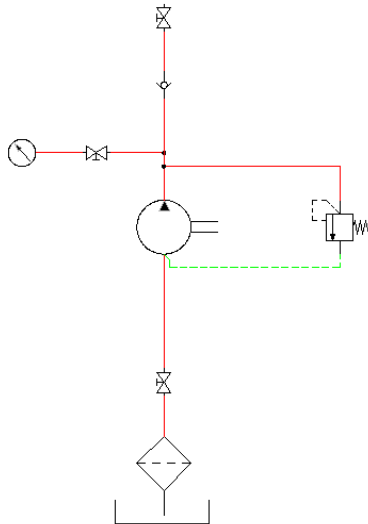



- 15 Click Schematic tab ► Insert Components panel ►  ► Insert







Hydraulic Components.

- 16 Insert and place the devices listed as shown in the following illustration. In the Insert/Edit Component dialog box, click OK after each insertion.

**NOTE** You can also insert the vertical or horizontal pipes first and then insert the components onto the pipe, one by one.

Icon	Symbol to Insert
	2 Way Valves ► Solenoid Spring Return -1 (insert as Vertical symbol)
	General Valves ► Checkvalve Flow Left (insert as a Vertical symbol)



Icon	Symbol to Insert
	Filters ► Filter (insert as a Vertical symbol)
	Restrictors ► Restrictor with Variable Output Flow
	Restrictors ► By-Pass Flow Regulator with Variable Output Flow
	Cylinders ► Single Acting Single Ended Piston Rod

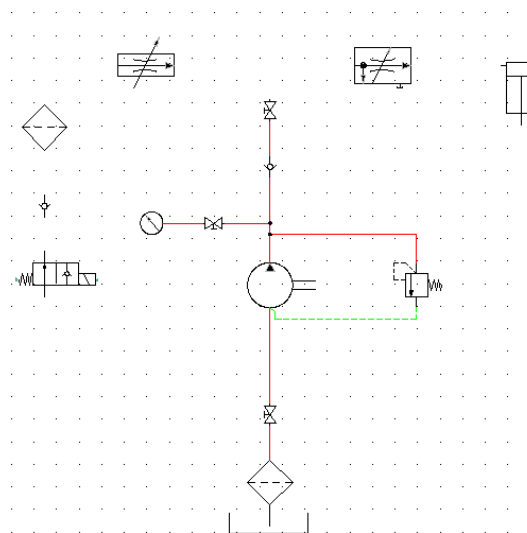

---

**TIP** Align the components horizontally and vertically using the Align tool to make inserting the pipes easier.

---

17 Click Schematic tab ► Insert Wires/Wire Numbers panel ► Wire.



**18** Connect the pipes from one control device to another as illustrated.

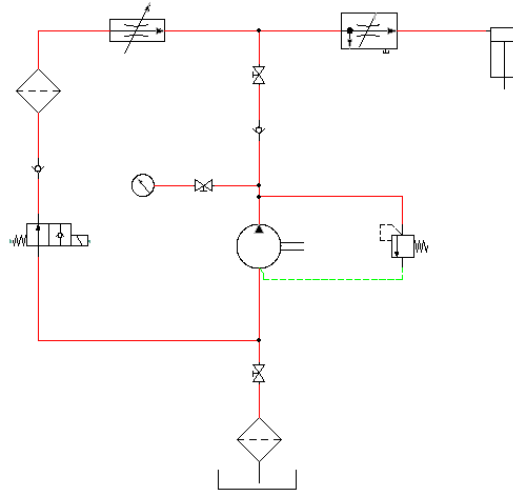

**19** Click Schematic tab ► Insert Components panel ►  ► Insert



Hydraulic Components.

**20** In the Insert Component: Hydraulic Symbol dialog box, click General



Valves.

**21** In the Hydraulic: General Valves dialog box, click Checkvalve Flow Left.



**22** Respond to the prompts as follows:

Specify insertion point: *Select to place the valve below the restrictor*

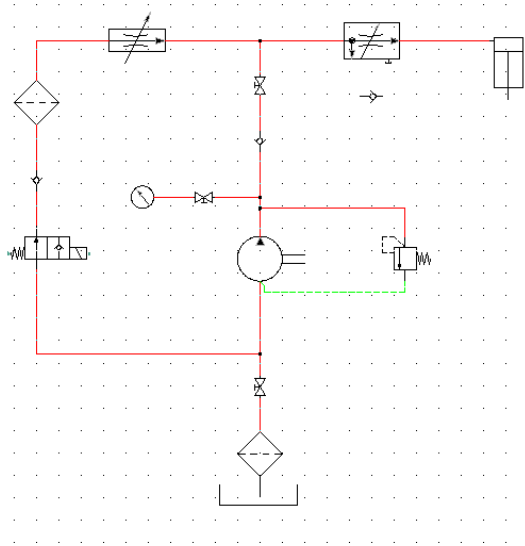

23 In the Insert/Edit Component dialog box, click OK.

24 Click Schematic tab ► Insert Wires/Wire Numbers panel ► Wire.

25 Connect the pipes as shown.



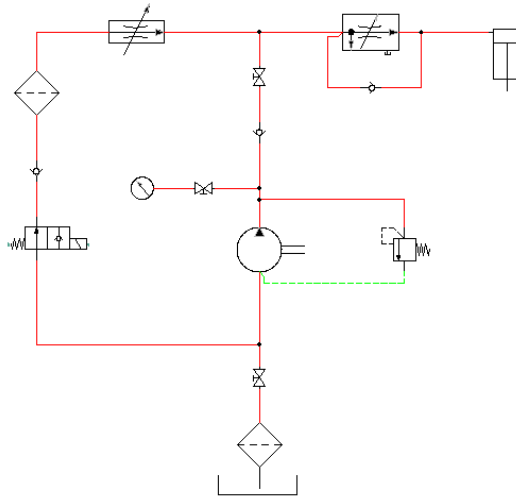

The hydraulic schematic diagram is complete.

If you want to create a pneumatic drawing, use the Insert Pneumatic Components tool on the Schematic tab ► Insert Components panel. Refer to the pneumatic demo drawing file (*Demo03.dwg*) in the Extra Library Demo project.

## Setting Up P&ID Drawings

Use the Project Manager to manage your P&ID drawings. From here, you can create a drawing and modify any pin

.

### Create a new drawing

- 1 Click Project tab ► Project Tools panel ► Manager.





2 In the Project Manager, click the New Drawing tool.

3 In the Create New Drawing dialog box, specify:

Name: AEGS13

Template: *Mouse over the edit box to verify ACAD\_Electrical.dwt is specified*

If *ACAD\_Electrical.dwt* is not specified, click Browse. Select it from the list of available templates.

Description 1: P&ID Example

Click OK.

---

**NOTE** If you want to set the component, wire number, cross-reference, style, and drawing format settings, click OK-Properties to proceed to Drawing Properties dialog box.

---

4 Enter *DSETTINGS* at the command prompt.

5 In the Drafting Settings dialog box ► Snap and Grid tab, turn on Snap and Grid and set the size of both to 0.125.

6 Click OK.



7 Click Schematic tab ► Other Tools panel ► Drawing Properties.

8 In the Drawing Properties dialog box ► Drawing Format tab, Scale section, make sure that the feature scale multiplier is set to 1.0 inch.

9 Click OK.

---

**NOTE** For metric unit, the following settings are recommended so that the wire connection points are placed on the grids for easier drafting. Grid and Snap Size = 2.5 mm; Feature scale multiplier =20 (scale factor = 20).

---

## Set up wire layers

- 1 Click Schematic tab ► Edit Wires/Wire Numbers panel ► Create/Edit



Wire Type.

- 2 In the Create/Edit Wire Type dialog box, click in the Wire Type #2 row and specify:

Wire Color: RED

Size: 25

The Layer Name is automatically created. The name RED\_25 is assigned to the wire layer you are creating.

- 3 Click Color.
- 4 In the Select Color dialog box, select red and click OK.
- 5 Click Linetype.
- 6 In the Select Linetype dialog box, select Continuous and click OK.
- 7 Click Lineweight.
- 8 In the Select Lineweight dialog box, select 0.30 and click OK.  
For this example, create three more wire types using the Create/Edit Wire Type dialog box.
- 9 In the Create/Edit Wire Type dialog box, specify:

Wire Type #3

Wire Color: RED

Size: 10

Color: Red

Linetype: Hidden2

Lineweight: default

Wire Type #4

Wire Color: GREEN

Size: 10

Color: Green

	Used	Wire Color	Size	Layer Name	Wire Numbering	USER1	USER2
1				WIRES	Yes		
2	X	RED	25	RED_25	Yes		
3	X	RED	10	RED_10	Yes		
4		GREEN	10	GREEN_10	Yes		
5							

**NOTE** For pipe runs in P&ID drawings, include the different linetypes from the *acad.lin* file. You can set up the wire types for pipes at the beginning of the drawing or before creating the pipes.

- 10 To set the Linetype for the GREEN\_10 wire layer, click Linetype.
- 11 In the Select Linetype dialog box, click Load.
- 12 In the Load or Reload Linetypes dialog box, click File.
- 13 In the Select Linetype File dialog box, select *acad.lin* and click Open.

**NOTE** The default location for the *acad.lin* file is *\Documents and Settings\{username}\Application Data\Autodesk\AutoCAD Electrical {version}\{release number}\{country code}\Support* or *\Users\{username}\AppData\Roaming\Autodesk\AutoCAD Electrical {version}\{release number}\{country code}\Support* on a Windows Vista or Windows 7 installation.

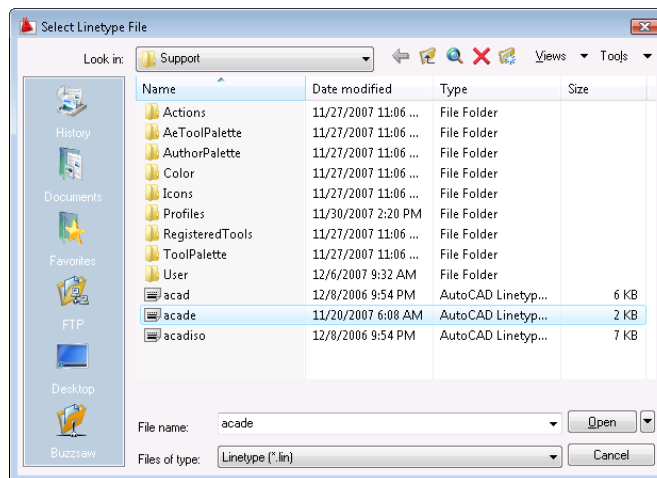

- 14 In the Load or Reload Linetypes dialog box, select Pneumatic Signal and click OK.

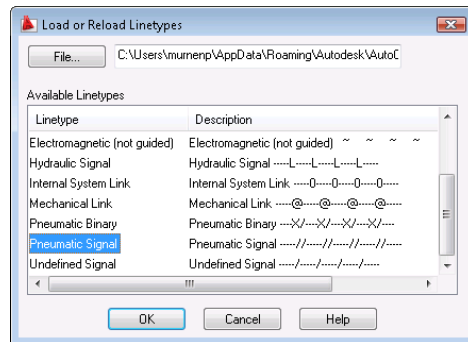





- 15 In the Select Linetype dialog box, select Pneumatic Signal and click OK.
- 16 In the Create/Edit Wire Type dialog box, click OK.

## Inserting P&ID Schematic Symbols

The P&ID symbol library in AutoCAD electrical includes equipment, tanks, nozzles, pumps, fittings, valves, actuators, logic functions, instrumentation, flow, and flow arrows. The P&ID symbol library consists of all the piping and instrumentation symbols. It is found at *\Documents and Settings\All Users\Documents\Autodesk\Acade {version}\Libs\Pid* or *\Users\Public\Documents\Autodesk\Acade {version}\Libs\Pid* on a Windows Vista or Windows 7 installation.

### Insert P&ID Symbols

- 1 Click Schematic tab ► Insert Components panel ►  ► Insert P&ID Components. 
- 2 In the Insert Component: Piping and Instrumentation Symbols dialog box, click Equipment. 
- 3 In the PID: Equipment dialog box, click Ball Mill. 



4 Respond to the prompts as follows:

Specify insertion point:

*Select to place the ball mill in the upper left corner of your drawing*

5 In the Insert/Edit Component dialog box, specify:

Component Tag: C-100

Description: Line 1: BALL MILL

Click OK.

6 Repeat steps 1-2.

7 In the PID: Equipment dialog box, click Conveyors.



8 In the PID: Conveyors dialog box, click Conveyor 1.



9 Respond to the prompts as follows:

Specify insertion point:

*Select to place the conveyor to the right and diagonally below the ball mill*

10 In the Insert/Edit Component dialog box, specify:

Component Tag: N-100

Description: Line 1: CONVEYOR

Click OK.

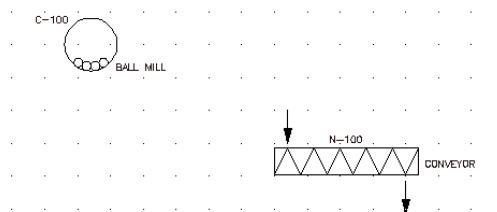

11 Repeat steps 1-2.

12 In the PID: Equipment dialog box, click Mixer 2.



13 Respond to the prompts as follows:

Specify insertion point:

Select to place the mixer to the right and diagonally below the conveyor

- 14 In the Insert/Edit Component dialog box, specify:

Component Tag: A-100

Description: Line 1: MIXER

Click OK.

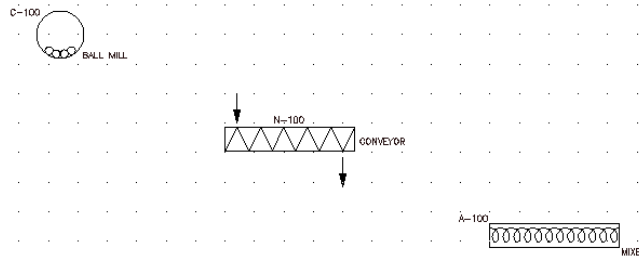

- 15 Click Schematic tab > Insert Components panel >  > Insert P&ID



Components.

- 16 Insert and place the devices listed as shown in the following illustration. In the Insert/Edit Component dialog box, click OK after each insertion.

Icon

Symbol to Insert



Valves > Gate Valve

In the Insert/Edit Component dialog box, clear the Component Tag



Equipment > Dryer

Component Tag = C-200; Description Line 1 = DRYER



Instrumentation > Discrete Instruments > Field Mounted

Component Tag = TE 201

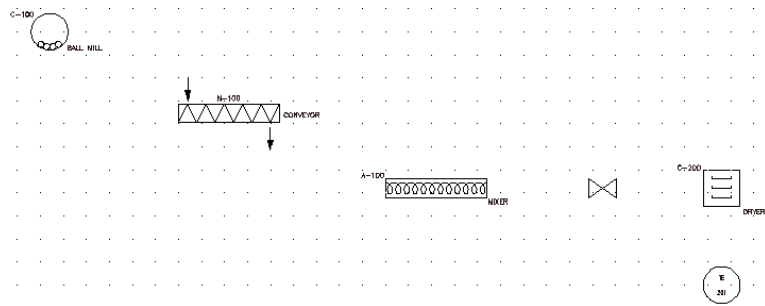

---

**TIP** Align the components horizontally and vertically using the Align tool to make inserting the pipes easier.

---

## Creating Pipes

In AutoCAD Electrical, different types of wires represent the type of running pipes that allow water or oil flows from one instrument to another.

### Insert wires as pipes

- 1 Click Schematic tab ► Insert Wires/Wire Numbers panel ► Wire.
- 2 Change the wire type to RED\_25:  
Specify wire start or [wireType/X=show connections]:  
*Enter T, press ENTER*  
Select the wire layer RED\_25. Click OK.
- 3 Connect the pipes as shown. Right-click to exit the command.



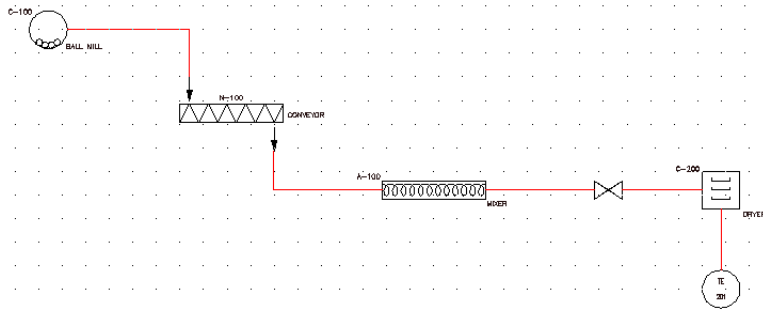

4 Click Schematic tab ► Insert Wires/Wire Numbers panel ► Wire.

5 Respond to the prompts as follows:

Specify wire start or [wireType/X=show connections]:

*Enter T, press ENTER*

Select the wire layer RED\_10. Click OK.

*Select the bottom of the discrete instrument*

Specify wire end or [Continue]:

*Drag the wire down a few spaces, press ENTER*

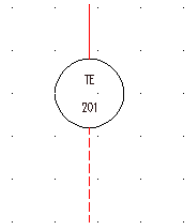

6 Click Schematic tab ► Insert Components panel ►  ► Insert P&ID

Components. 

7 In the Insert Component: Piping and Instrumentation Symbols dialog

box, click Flow Arrows. 

8 In the PID: Equipment dialog box, click Flow Arrow Down. 

9 Respond to the prompts as follows:

Specify insertion point:

Select to place the flow arrow at the bottom of the new wire

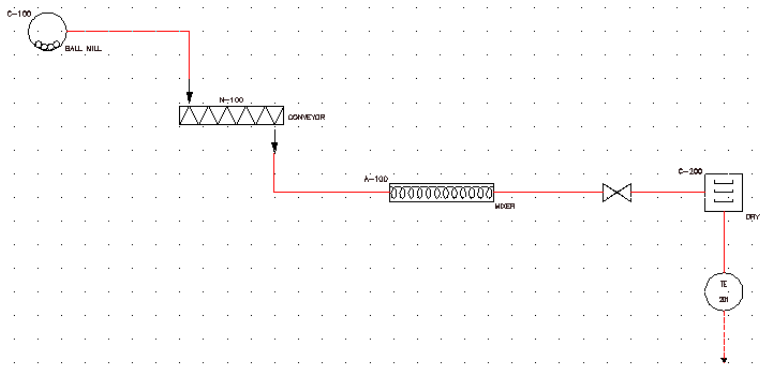

The P&ID diagram is complete.

If you want to see how to expand the P&ID drawing, refer to the P&ID demo drawing file (*Demo01.dwg*) in the Extra Library Demo project.

# Symbol Builder

## Symbol Builder - Introduction

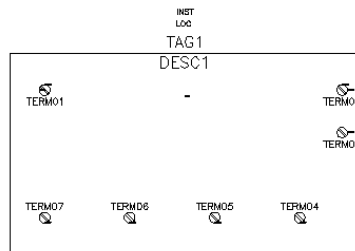

Create custom symbols with Symbol Builder.

Time required 30 minutes

Prerequisites: Copy all files located in

**Windows XP** *Documents and Settings\{username}\My Documents\Acade {version}\Aedata\Tutorial\Aegs\Symbol Builder*  
to  
*Documents and Settings\{username}\My Documents\Acade {version}\Aedata\Proj\Aegs*

**Windows Vista, Windows 7** *Users\{username}\Documents\Acade {version}\Aedata\Tutorial\Aegs\Symbol Builder*  
to  
*Users\{username}\Documents\Acade {version}\Aedata\Proj\Aegs*

You learn to:

- Create a schematic parent
- Add attributes
- Add wire connections
- Save the symbol

## Creating custom symbols

You can use the Symbol Builder to create an AutoCAD Electrical symbol easily. This utility builds a smart schematic symbol by either adding AutoCAD Electrical attributes to the geometry of the symbol, or by converting text entities to AutoCAD Electrical attributes. You can also use AutoCAD attribute definition and editing commands to do the same thing. This tool makes the task easier because you quickly pick and place attributes. It tracks what attributes are present and checks your work to make sure that any required attributes are not omitted.

---

**NOTE** If you exit out of the Symbol Builder, restart it. On the Select Symbol/Objects dialog box, click Select objects and select any graphics and attributes you added so far. You can then start from where you left off.

---

### Create a parent schematic symbol

- 1 If AEGS is not the active project, in the Project Manager, right-click AEGS and select Activate.
- 2 In the Project Manager, double-click AEGS to expand the drawing list.
- 3 Open *AEGS03.dwg*.
- 4 Draw a rectangle anywhere on the drawing.

---

**TIP** It is easiest to draw it in the white space on the left-hand side of the drawing.

---



- 5 Click Schematic tab ► Other Tools panel ► Symbol Builder



drop-down ► Symbol Builder.

- 6 In the Select Symbol/Objects dialog box, Attribute template section, browse to the Library path *C:\Documents and Settings\All*

*Users\Documents\Autodesk\Acade {version}\jic125* (or  
*C:\Users\Public\Documents\Autodesk\Acade {version}\jic125* on a Windows  
Vista or Windows 7 installation).

- 7 In the Attribute template section, select Symbol: Horizontal Parent, Type: Generic.
- 8 In the Select from drawing section, click Select objects, select the rectangle, and press ENTER.
- 9 Select OK.

## Adding attributes

In this example, you add the attributes: TAG1, DESC1, LOC, INST, FAMILY, MFG, CAT, and ASSYCODE. You are not limited to these attributes and you can include your own user-defined attributes on the AutoCAD Electrical block files.

---

**NOTE** The TAG1 attribute is the only one required for a parent schematic symbol. The other attributes in the Required section are expected on a parent schematic symbol, however the symbol is recognized as a parent symbol without them.

---

### Add attributes

- 1 If the Symbol Builder Attribute Editor is not visible,

Click Symbol Builder tab ► Edit panel ► Palette Visibility Toggle.





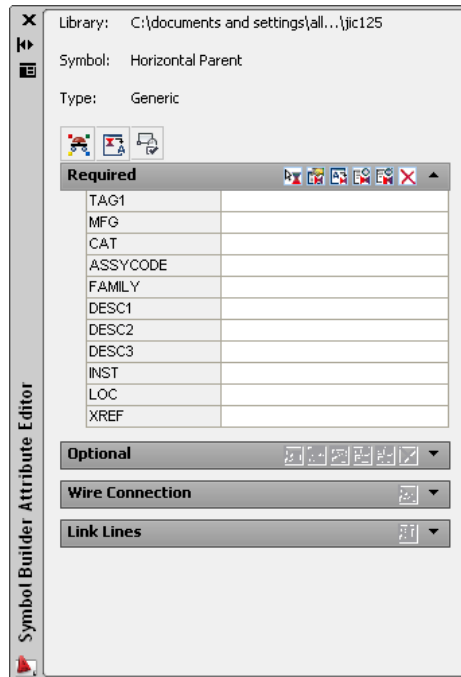

Use this palette to assign attributes to the rectangle as well as set the height and justification for each attribute. The palette displays the AutoCAD Electrical attributes that you can insert and define as part of the symbol. Once an attribute is inserted on the symbol a check mark displays next to it and you cannot insert it again. AutoCAD Electrical allows only one insertion of each attribute.

- 2 In the Symbol Builder Attribute Editor, select TAG1 and click the



Properties tool.

Enter:

Value: PS

It is the default code used as the %F value of the tag format (such as “CR”, “PB”, “LT”)

Height: 0.125

Justify: Center

Click OK.

- 3 Click the Insert Attribute tool. 

Insert the attribute above the rectangle.

In the Symbol Builder Attribute Editor, notice the check mark next to the TAG1 attribute. Continue placing the rest of the attributes.

- 4 In the Symbol Builder Attribute Editor select DESC1.

Click the Insert Attribute tool. 

- 5 Insert the attribute below TAG1.

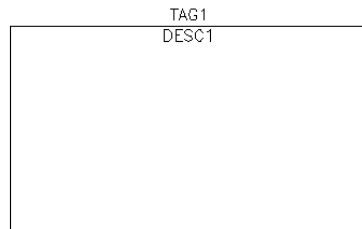

- 6 Insert the LOC and INST attributes as indicated.

- 7 Insert the FAMILY attribute near the center of the rectangle.

- 8 With FAMILY still highlighted in the Symbol Builder Attribute Editor,

select the Properties tool. 

Enter:

Value: PS

Click OK.

This assigns the %F value to the FAMILY attribute inserted.

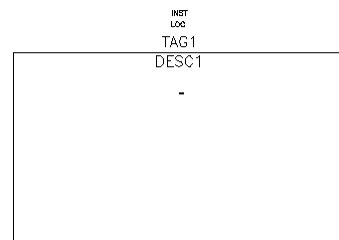

- 9 Select MFG and insert near the center of the rectangle. Repeat for CAT and ASSYCODE.

## Adding wire connections

If an X?TERMxx of the component (for example, "X2TERM01") wire connection-point attribute lies within the small trap distance of the end of a wire, then AutoCAD Electrical interprets the component connected to the wire. The only time the trap distance changes is when you change the Feature Scale Multiplier in the Drawing (or Project) Properties ► Drawing Format dialog box.

---

**NOTE** Components with closely spaced wire connection points may not be processed properly if the connection points fall within the AutoCAD Electrical trap distance of one another.

---

A wire connection attribute can have a related terminal text attribute, TERMxx, and terminal description attribute, TERMDESCxx. The "xx" is a two-digit number (starting at 01) that is used to match up with the corresponding X?TERMxx wire connection attribute.

### Insert connection points

- 1 In the Symbol Builder Attribute Editor, expand the Wire Connection section.
- 2 In the Direction / Style list, select Others.

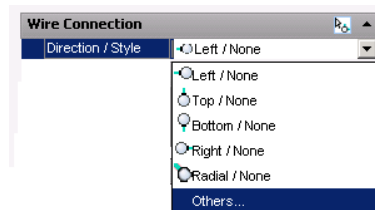

- 3 On the Insert Wire Connection dialog box select Terminal Style: Screw. This terminal style inserts both the graphic to represent the screw and the wire connection points.
- 4 Check Use this configuration as default. It directs Symbol Builder to use the current Terminal Style and Scale as the default in the Symbol Builder Attribute Editor.

- 5 Select Connection direction: Left & Top.  
It determines the direction the wire attaches to the component.
- 6 Enter "L" as the value for TERM01 in Pin Information.
- 7 Select X2TERMDDESC01 in Pin Information and click Delete.
- 8 Click Insert.
- 9 Select the Insert Wire Connection tool and insert the terminal in the upper left-hand corner as shown.

---

**NOTE** Always use AutoCAD Snap to insert the wire connection point.

---

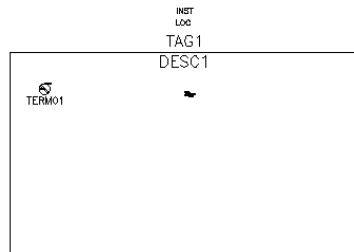

- 10 Back on the Symbol Builder Attribute Editor, expand the Wire Connection Direction / Style list and select Right & Top / Screw.
- 11 Select the Insert Wire Connection tool and insert the terminal in the



upper right-hand corner.

You can continue to insert wire connections until you press ENTER by entering the characters indicated in the command line prompt followed by a space. You can also select from the Direction / Style list.

- 12 Insert the rest of the terminals as follows:
  - TERM03: Right  
Insertion Point: below TERM02
  - TERM04: Bottom  
Insertion Point: in the lower right-hand corner
  - TERM05: Bottom  
Insertion Point: to the left of TERM04
  - TERM06: Bottom

Insertion Point: to the left of TERM05

TERM07: Bottom

Insertion Point: to the left of TERM06

- 13 Press Enter if necessary to return to the command prompt.
- 14 On the Symbol Builder Attribute Editor, expand the Pins section. Enter the Pin values as follows:

TERM02 : **N**

TERM03 : **GND**

TERM04 : -

TERM05 : -

TERM06 : +

TERM07 : +

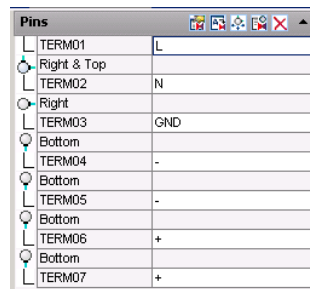

Pin Name	Value
TERM01	L
Right & Top	
TERM02	N
Right	
TERM03	GND
Bottom	
TERM04	-
Bottom	
TERM05	-
Bottom	
TERM06	+
Bottom	
TERM07	+

Your drawing looks like the following image:

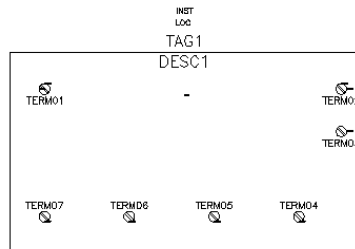

## Saving the symbol

You have two options for saving the symbol: WBlock or Block. WBlock creates the symbol .*dwg* file while Block creates the symbol for this drawing file only.

### Save and insert the symbol onto a drawing



- 1 Click Symbol Builder tab ► Edit panel ► Done.
- 2 On the Close Block Editor: Save Symbol dialog box, in the Base point section, click Pick point. Select a point in-line with the top terminals so that it is easy to place on a wire later.
- 3 Select WBlock.
- 4 Enter a file name or accept the default.
- 5 Click OK.
- 6 When asked to insert the symbol, click Yes.
- 7 Place the symbol on the empty wire on the left-hand side of the drawing.

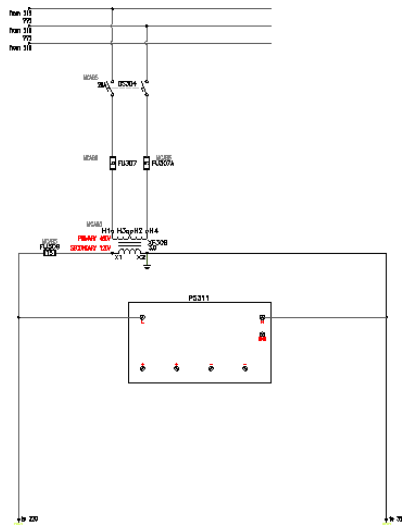

The wire breaks, the component tag inserts, and the wires connect to the symbol.

---

**NOTE** New symbols you create can also be inserted with the AutoCAD Electrical Insert Component command. You can add your new symbol to the icon menu. Or, you can select it from the Type it or Browse dialog box file selection options in the icon menu.

---

- 8 In the Insert/Edit Component dialog box, click OK.

## Migration of AutoCAD Data

### Migration of AutoCAD Data - Introduction

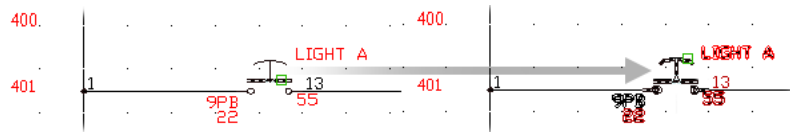

Convert non blocked geometry and text to a fully functional AutoCAD Electrical block insert.

Time required 45 minutes

Prerequisites: Copy all files located in

**Windows XP** *Documents and Settings\{username}\My Documents\Acade {version}\Aedata\Tutorial\Aegs\Convert*  
to  
*Documents and Settings\{username}\My Documents\Acade {version}\Aedata\Proj\Aegs*

**Windows Vista, Windows 7** *Users\{username}\Documents\Acade {version}\Aedata\Tutorial\Aegs\Convert*  
to  
*Users\{username}\Documents\Acade {version}\Aedata\Proj\Aegs*

You learn to:

- Convert non blocked geometry and text to a schematic component
- Add wire connections
- Add geometry to the block
- Convert non blocked geometry and text to a panel footprint

## About Tagging and Linking Tools

This chapter describes using the tagging and linking tools in AutoCAD® Electrical to convert non blocked geometry and text to a fully functional AutoCAD Electrical-aware block insert.

AutoCAD Electrical has tagging and linking tools that enable non blocked geometry to be made aware of AutoCAD Electrical. The existing geometry stays in place and is unblocked. Key text entities are converted to attributes with user picks and are linked into a generic, non graphical block insert. Wire connection attributes can also be merged into this generic block insert. The process to convert it from dumb text, circle, and line entities takes only moments to complete and the result appears as a fully functional AutoCAD Electrical-aware block insert.

## Exploding Block and Attributes

The Special Explode tool in AutoCAD Electrical explodes attributes and blocks to geometry and text entities while maintaining the value previously defined in the attributes. You can take advantage of the tagging tools to modify the text entities to attributes and the linking tools to make various blocks.

### Explode AutoCAD® blocks

- 1 If AEGS is not the active project, activate the AEGS project.  
If AEGS is in the list of open projects:
  - Select AEGS and right-click.
  - Click Activate.If AEGS is not in the list of open projects:
  - Select the project list drop-down.
  - Click Open Project.
  - On the Select Project File dialog box, navigate to and select the *AEGS.WDP* file.
  - Click Open.
- 2 In the Project Manager, double-click AEGS to expand the drawing list.  
There are four drawings in the project, *Convert-01.dwg* through *Convert-04.dwg*.



3 Open *Convert-03.dwg*.

4 Zoom in on the components in the upper left-hand corner of the drawing.

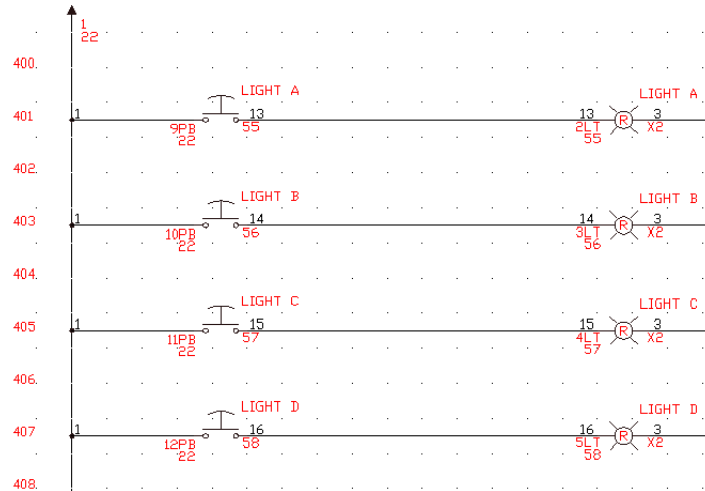

5 Click Conversion Tools tab ► Tools panel ► Special Explode.

Use the Special Explode tool to explode attributes and blocks to geometry and text entities while maintaining the value previously defined in the attributes. You can take advantage of the tagging tools to modify the text entities to attributes and the linking tools to make various blocks.

6 Respond to the prompts as follows:

Select objects:

*Select push button lights A - D (including all graphics and text) on lines 401 - 407 (use either single picks or window-select), right-click*

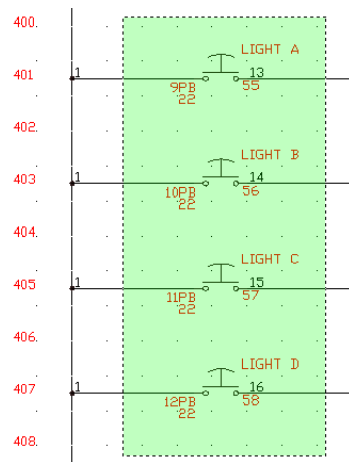

The blocks explode into separate text entities and geometry.

## Tagging Schematic Components

Use the AutoCAD Electrical Tagging tools to convert text entities into an attributed block. Through the insertion of a template block, you have control over which attributes are inserted and visible. All necessary attribute definitions are automatically placed. During the tagging process, the text entity is removed and replaced with a template block file that contains multiple attributes used in AutoCAD Electrical.

### Tagging Results:

- The selected text entities are replaced with a template block file.
- The TAG attribute takes on the value of the converted text.
- The TAG attribute is set to fixed.
- The TAG attribute takes on the same ACAD properties as the tagged text.

### Tag schematic components

- 1 Click Conversion Tools tab ► Schematic panel ► Tag Component.



2 Respond to the prompts as follows:

Select objects: *Select 9PB, 10PB, 11PB, and 12 PB, right-click*

---

**NOTE** You may have to right-click several times to exit the command.

---

The text changes color to indicate that it has been tagged. The color of the TAG attribute is by layer. The attribute is the same layer as defined on the WD\_M block. You can now link the descriptions and wire numbers.



3 Click Reports tab ► Schematic panel ► Reports.

4 In the Schematic Report dialog box, specify:

Report Name: Component

Active Drawing

Click OK.

5 If asked to save the drawing, click Yes.

In the Report Generator dialog box, notice that 9PB-12PB are listed in the TAGNAME column of the report

6 In the Report Generator dialog box, click Close.

## Linking Schematic Attributes

Use the AutoCAD Electrical Linking tools to associate non blocked text to previously placed template blocks. Through the modification of a template block, you have control over which attributes are inserted and visible. All necessary attribute definitions are placed using the properties of the existing text entities, such as justification, height, and location. If multiple template block files are selected, the value of the text is added to the previously defined template block attributes as hidden attributes and the text is not removed.

### Linking Results:

- The selected text entities are replaced with an AutoCAD Electrical attribute.
- Colors change to distinguish what has been already converted as defined in the WD\_M block.
- Temporary lines display the link.

The Link Descriptions tool links simple text as Description 1-3 attributes on an AutoCAD Electrical block file. You can link them as description attributes to one or more existing template block definitions. During the conversion process, the text entity is removed and replaced with the next available description attribute, up to 3.

## Link descriptions

- 1 Click Conversion Tools tab ► Attributes panel ► Link Descriptions.



- 2 Respond to the prompts as follows:

Select objects: *Select 9PB, right-click*

Select text to fill in next available DESC attribute:

*Select LIGHT A, right-click*

Select objects: *Select 10PB, right-click*

Select text to fill in next available DESC attribute:

*Select LIGHT B, right-click*

Select objects: *Select 11PB, right-click*

Select text to fill in next available DESC attribute:

*Select LIGHT C, right-click*

Select objects: *Select 12PB, right-click*

Select text to fill in next available DESC attribute:

*Select LIGHT D, right-click*

---

**NOTE** You may have to right-click several times to exit the command.

---

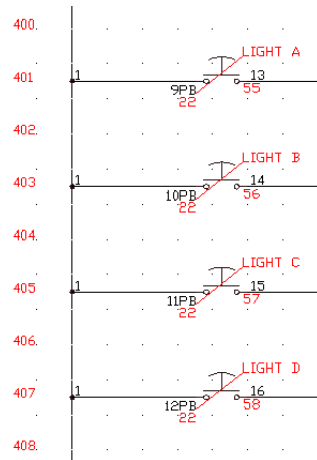

Colors change to distinguish what has been converted and temporary lines display the link.



- 3 Click Reports tab ► Schematic panel ► Reports.
- 4 In the Schematic Report dialog box, specify:  
 Report Name: Component  
 Active Drawing  
 Click OK.
- 5 If asked to QSave the drawing, click Yes.  
 In the Report Generator dialog box, notice that 9PB-12PB are still listed in the TAGNAME column of the report.
- 6 In the Report Generator dialog box, click Change Report Format.
- 7 In the Component Data Fields to Report dialog box, select Desc1 from the Available Fields list.  
 Desc1 moves into the Fields to report list. These are the fields to display in the Component report.

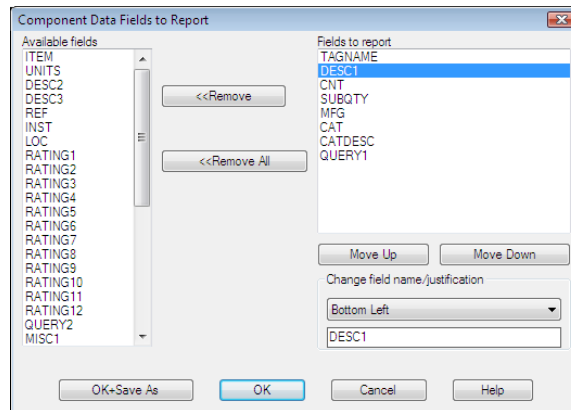

8 Click OK.

The Report Generator dialog box now lists the TAGNAME and DESC1 values from the active drawing.

9 In the Report Generator dialog box, click Close.

## Adding Wire Connections

Wire connection attributes can also be merged into the new generic block insert. The Add Wire Connections tool in AutoCAD Electrical adds wire connection attributes to the existing tagged block file. Select line endpoints or geometry to add the appropriate wire connection attributes to. A new block definition is created with the newly added wire connections. You can later create a block file if the block is exploded.

### Wire Connection Results:

- Visual indicators (x) appear where the wire connection attributes have already been applied.
- Wire connection attributes, terminal attributes, and terminal description attributes are added.
- The block definition is automatically modified during the attribute addition process.
- Terminal attribute colors change to distinguish what has been already converted as defined in the WD\_M block.

## Convert device pins to wire connection attributes

- 1 Click Conversion Tools tab ► Tools panel ► Add Wire Connections.



- 2 Respond to the prompts as follows:

Select block TAG or PLC Address: *Select 9PB*

Select end of wire (P=Pick Location): *Enter P and press ENTER*

Select location (W=Wire):

*Press SHIFT + right-click to select Endpoint from the Snap options, select the end point of the first wire on line 401*

In the Wire Direction dialog box, select from left.

Select TERM01 text object: *Select 22 (underneath 9PB TAG)*

---

**NOTE** Visual indicators (x) appear where the wire connection attributes have been applied.

---

Select location (W=Wire):

*Press SHIFT + right-click to select Endpoint from the Snap options, select the end point of the second wire on line 401*

In the Wire Direction dialog box, select from right.

Select TERM02 text object: *Select 55 (underneath line 401), right-click*

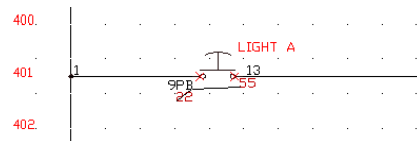

You are back at the prompt to Select block TAG or PLC Address.

- 3 Repeat for 10PB - 12PB.

---

**NOTE** You may have to right-click several times to exit the command.

---

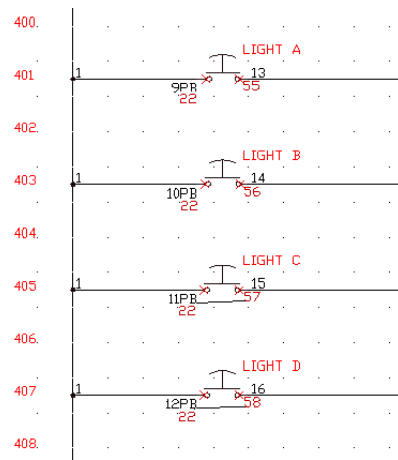

Pause the mouse over 9PB - 12 PB. The text, wire connection attributes, and description text all highlight. We still must convert the wire number text and add the geometry to our block.

- 4 Click Schematic tab ► Edit Wires/Wire Numbers panel ► Create/Edit



Wire Type.

- 5 In the Create/Edit Wire Type dialog box, select Make all Lines Valid Wires and click OK.
- 6 Click Conversion Tools tab ► Tools panel ► Convert Text to Wire



Number.

- 7 Respond to the prompts as follows:  
 Select LINE near wire number text:  
*Select the left endpoint of the wire with the text 13 above it (line 401)*  
 Select existing wire number text to convert: *Select text 13*
- 8 While you are still in the command, repeat for text 14 - 16 on lines 403 - 407.
- 9 Right-click to exit the command.



## Adding Geometry

The Add Geometry tool in AutoCAD Electrical adds AutoCAD geometry to a template block file to be created as part of a unique block instance. It creates a block definition with the newly added geometry. You can later create a block file if the block is exploded.

### Add Geometry Results:

- TAG1, TAG2, PLC TAG, and TAGSTRIP attributes are defined and selected first.
- The block definition is automatically modified.
- The color of the geometry changes by layer to distinguish what has been already converted as defined in the WD\_M block.

### Add geometry to the block



- 1 Click Conversion Tools tab ► Tools panel ► Add Geometry.
- 2 Respond to the prompts as follows:

Select block for additional geometry: *Select 9PB*

Select objects: *Select the graphics for the push button, right-click*

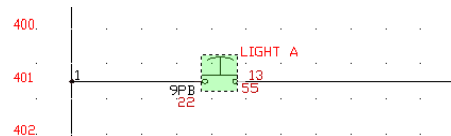

Specify insertion point: *Select the middle of the push button*

The geometry is associated to the template block files. Check that everything has been tied to the block by mousing-over 9PB. The text, wire connection attributes, description text, and geometry highlights.

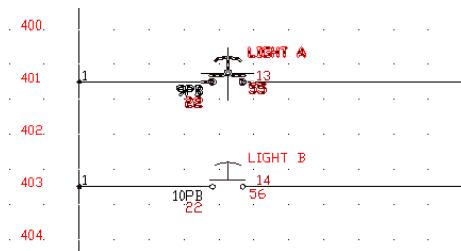

- 3 Repeat steps 1 -2 for 10PB, 11PB, and 12 PB.  
Your blocks are now AutoCAD Electrical-smart.

## Tagging and Linking Panel Components

The AutoCAD Electrical Tagging and Linking tools work on panel components the same way they work on schematic components.

### Tag and link panel components

- 1 Open *Convert-04.dwg*.
- 2 Zoom in on the components in the middle of the drawing.

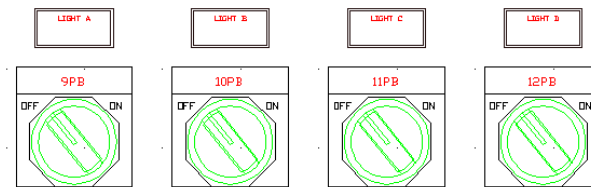

- 3 Click Conversion Tools tab ► Tools panel ► Special Explode. 

- 4 Respond to the prompts as follows:

Select objects:

*Select push button lights A - D (including all graphics and text) (use either single picks or window-select), right-click*

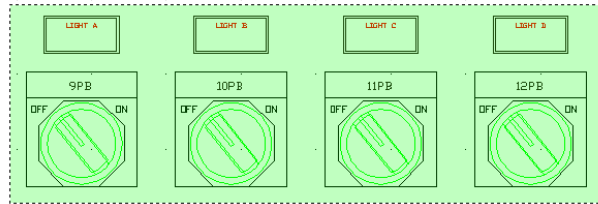

The blocks explode into separate text entities and geometry.

The Tag Panel Component tool makes selected text entities an attributed block file with the P\_TAG1 attribute visible. The template block file (ACE\_P\_TAG1\_CONVERT.DWG) contains attributes for a panel component.



5 Click Conversion Tools tab ► Panel panel ► Tag Footprint.

6 Respond to the prompts as follows:

Select objects: *Select 9PB, 10PB, 11PB, and 12 PB, right-click*

---

**NOTE** You may have to right-click several times to exit the command.

---

The text changes color to indicate that it has been tagged. The color of the PTAG attribute is by layer. The attribute is the same layer as defined on the WD\_M block.

7 Click Conversion Tools tab ► Attributes panel ► Link Descriptions.



8 Respond to the prompts as follows:

Select objects: *Select 9PB, right-click*

Select text to fill in next available DESC attribute:

*Select LIGHT A, right-click*

---

**NOTE** You may have to right-click several times to exit the command.

---

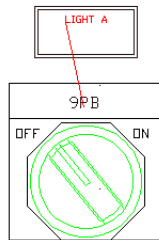

## Updating Panel or Schematic Components

Once a panel component has a component tag assigned, it is automatically linked to the schematic component with the same tag. Updates to either the schematic or panel component prompt an update to the related component.

### Surf to the related schematic component



- 1 Click Project tab ► Other Tools panel ► Surfer.
- 2 Respond to the prompts as follows:  
Select tag for "Surfer" trace (or <Enter> to type it): *Select 9PB*
- 3 In the Surf dialog box, double-click the component marked with type "p."

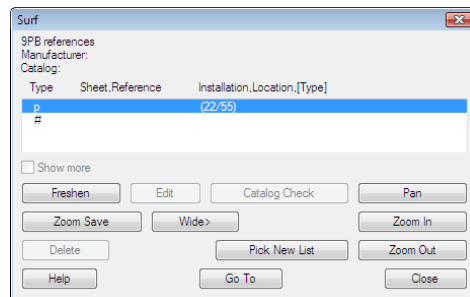

Surfer goes to the schematic drawing and zooms on the schematic component.

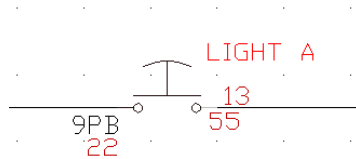

- 4 If asked to save the drawing, click Yes.
- 5 In the Surf dialog box, click Edit.
- 6 In the Component Insert/Edit dialog box, change the description to LIGHT 1 and click OK.  
The Update Other Drawings dialog box displays. This dialog alerts that other drawings in the project set include child components or related panel components.

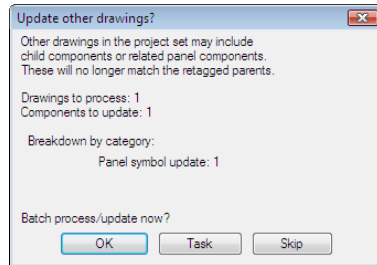

- 7 If asked to save the drawing, click Yes.
- 8 In the Update Other Drawings dialog box, click OK.



- 9 Click Project tab ► Other Tools panel ► Surfer.
- 10 Respond to the prompts as follows:  
Select tag for "Surfer" trace (or <Enter> to type it): *Select 9PB*
- 11 In the Surf dialog box, double-click the component marked with type "#."  
Surfer goes to the panel layout drawing and zooms on the physical representation of the push button. Notice that the description for 9PB updated to reflect the change you made to the schematic component.

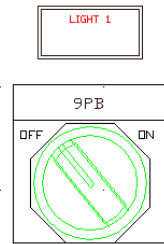

12 In the Surf dialog box, click Close.

## Interoperability: Inventor and AutoCAD Electrical

### Introduction

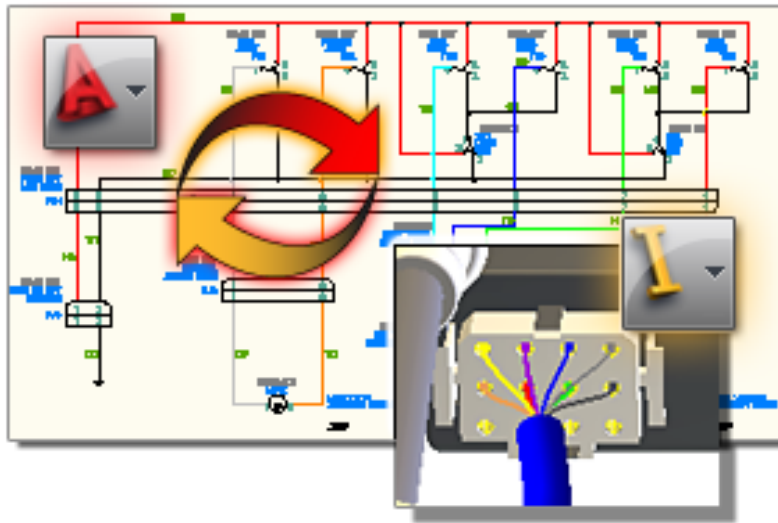

Learn to use AutoCAD Electrical and Inventor interoperability to digitally prototype and document your electrical designs.

Time required 35 minutes

- Prerequisites:
- Familiarity with both AutoCAD Electrical and Inventor is recommended but not necessary. This tutorial is designed to work whether you have only AutoCAD Electrical or Inventor, or if you have both programs.
  - Know how to navigate the model space with the various view tools.

Tutorial file used 900501.dwg  
Copy all files located in

**Windows XP** *Documents and Settings\{username}\My Documents\Acade {version}\Aedata\Tutorial\Aegs\Interoperability*  
to  
*Documents and Settings\{username}\My Documents\Acade {version}\Aedata\Proj\Aegs*

**Windows Vista, Windows 7** *Users\{username}\Documents\Acade {version}\Aedata\Tutorial\Aegs\Interoperability*  
to  
*Users\{username}\Documents\Acade {version}\Aedata\Proj\Aegs*

## Introduction (continued)

In this tutorial, you learn how to interchange data between AutoCAD Electrical and Inventor. In the first half of the tutorial, the data exchange direction is from AutoCAD Electrical to Inventor.



In the second half, the exchange direction is from Inventor to AutoCAD Electrical.



You do not need both programs to derive benefit from this exercise. The two XML files generated in this workflow are also included in the tutorial sample files. Therefore, if you have only one program, you can still perform the XML import operation.

If you have only AutoCAD Electrical, you can review the Inventor portion of the tutorial. Then you can perform the import steps and subsequent steps on the [Import the Inventor data](#) on page 1973 page. You are directed to perform this import at the appropriate point.

---

**NOTE** This tutorial was created using AutoCAD Electrical 2011 and Inventor 2011 Professional. You need the Professional or Routed Systems versions for the Cable and Harness functionality.

---

## Part 1: 2D to 3D



In this half of the tutorial, you learn how to export your data from AutoCAD Electrical to Inventor. The sample DWG file is a wiring diagram used for a seat assembly. The assembly uses electric motors to provide adjustments to the seat position.

### Open DWG

- 1 Start AutoCAD Electrical.
- 2 Open the Project Manager. If this window is closed:

Click Project tab ► Project Tools panel ► Manager.



- 3 Select **Open Project** from the project drop-down menu.
- 4 Select the project **ace\_inv.wdp** and click **Open**. The project is in the location described on the introduction page.
- 5 Expand the *ACE\_INV* project, and then double-click **900501.dwg**.



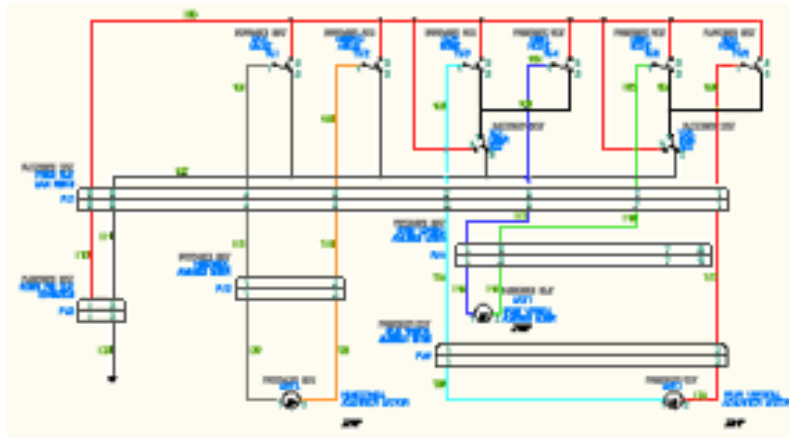

Ensure that the drawing is in Model Space.

## Rename component tags



Before you export this data to Inventor, you update the PASSENGER SEAT component tags. Assume that this drawing was copied forward and is now ready to modify and use for the driver seat.

- 1 Click Schematic tab ► Edit Components panel ► Retag Components

drop-down ► Find/Edit/Replace Component Text.



- 2 Select **Active drawing (all)** in the *Find/Edit/Replace Electrical Component Text* dialog box, and click **OK**.
- 3 Set the following options and take the following actions in the *Find/Edit/Replace - this Drawing (all)* dialog box.
  - Select **Find** in the *Location Code* group.
  - Click **List**, then select **PASSENGER SEAT** in the *Loc values* dialog box, and click **OK**.
  - Select **Replace**, and then enter **DRIVER SEAT** in the text box.

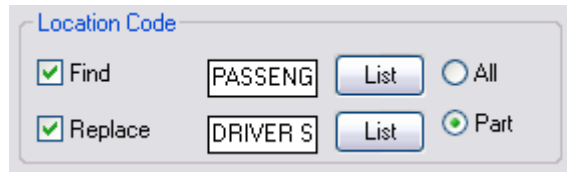

- Click **Start Search**, and review the results in the *Match 1 of 16* dialog box.
- Click **Replace All**, and then click **Yes, Make Changes**. The component tags are changed to DRIVER SEAT.

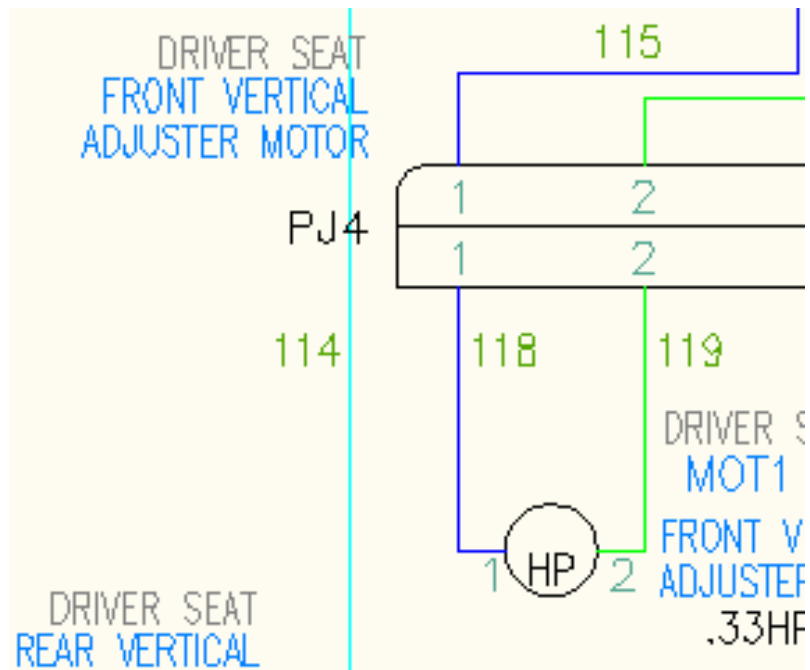

- Click **Cancel**.
- 4 Save the drawing.

## Export to XML



Next, you export the electrical data contained in your AutoCAD Electrical digital prototype to an XML file. You use this XML file later to import the data into Inventor.



- 1 Click **Import/Export Data** tab ► **Export** panel ► **Inventor**.
- 2 Ensure **Active Drawing** is selected in the *Autodesk Inventor Professional Export* dialog box, and click **OK**.
- 3 Save to the same directory you copied the tutorial files in the *Autodesk Inventor Professional XML File Export* dialog box. Use **driverseat\_from\_ace** for the file name.
- 4 Click **Save**.

## Set the project



- 1 Start Inventor.
- 2 Select **Get Started** ► **Launch** ► **Projects**.
- 3 Click **Browse**.
- 4 Browse to *Tutorial Files/Automotive* folder, and select **interop.ipj**.
- 5 Click **Open**.
- 6 Click **Done** in the *Projects* editor.

## Open the dataset



- 1 Open **100500.iam**. The file is contained in the 1000 folder. The model opens in the Default design view representation.



This sample has been stripped down to reduce data size. The complete seat looks like the following:



2 Switch to the **Electrical** design view representation.

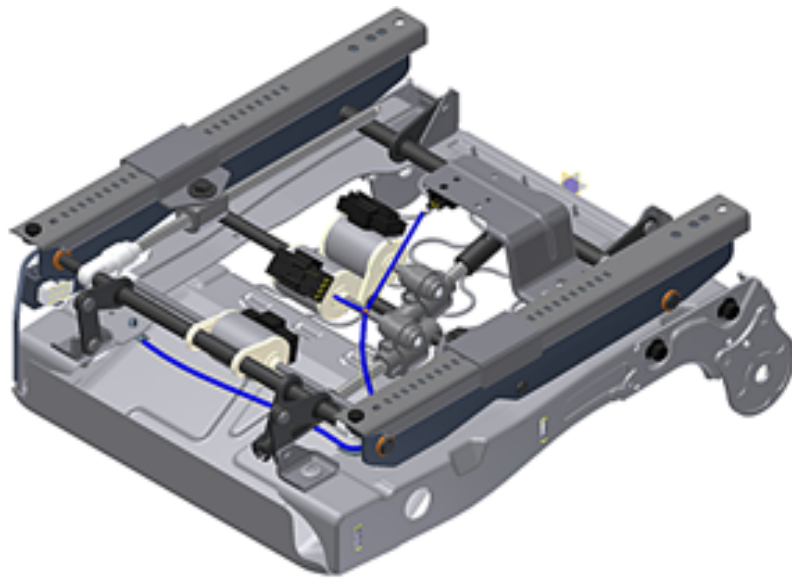

Orbit and zoom your view as you progress through the workflow, as needed. It can be helpful to approximate the following view as you get started with the workflow.

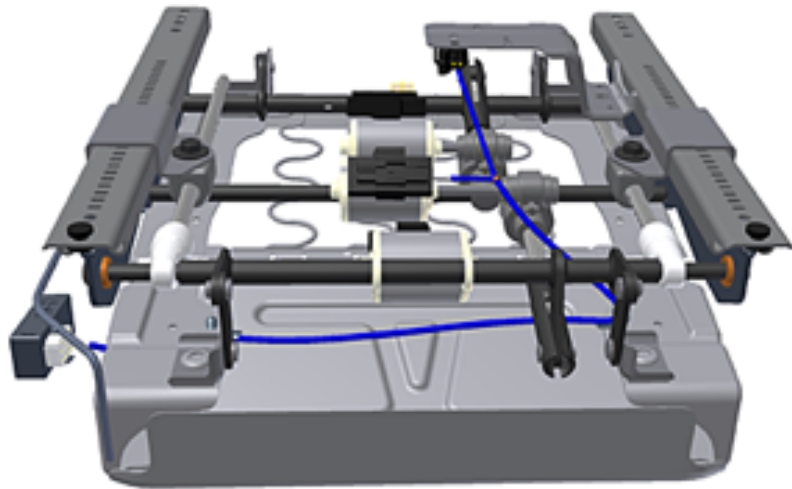

## Add harness segments



Now you add the two harness segments.

- 1 Double-click **Harness1** in the browser to edit the harness. Be careful to edit the harness assembly rather than the harness part.
- 2 Select **Cable and Harness** ► **Create** ► **Create Segment**.
- 3 Select the existing segment near the front of the seat to place the first point. The exact selection location is not critical.

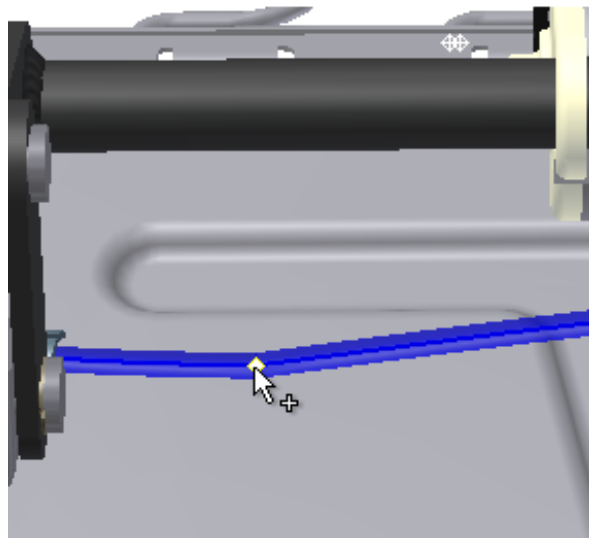
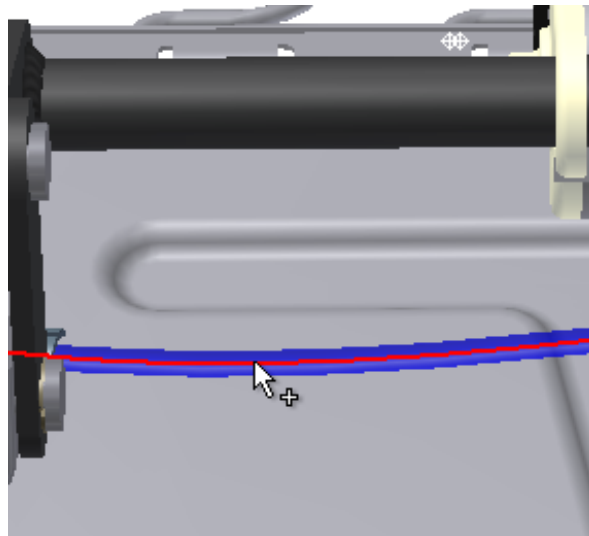

- 4 Select the existing work point to set the next segment point. The two work points are very close together. You may need to zoom in to see them clearly.



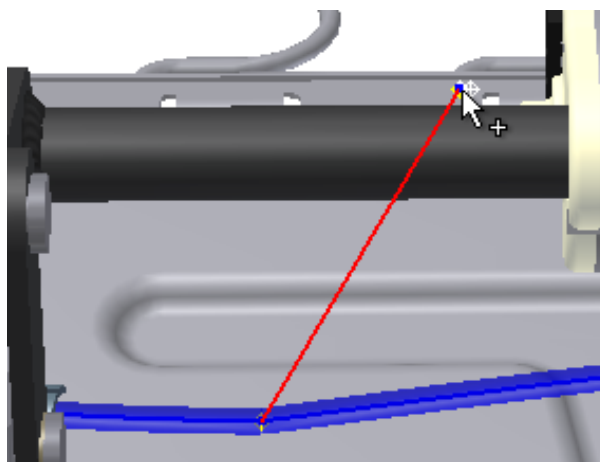

5 Select the other work point to set the final point.

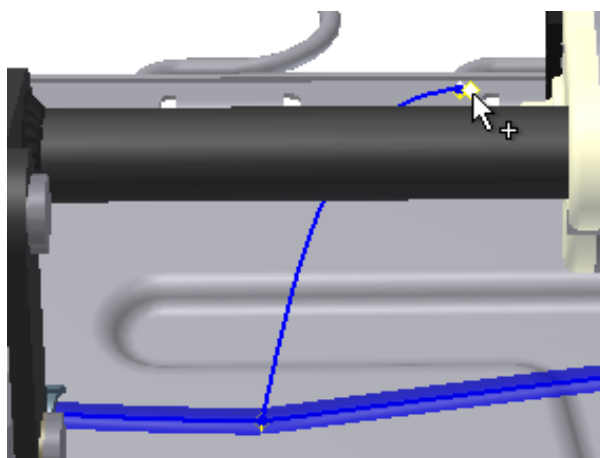

6 Right-click, and select **Continue**. The first segment is created.

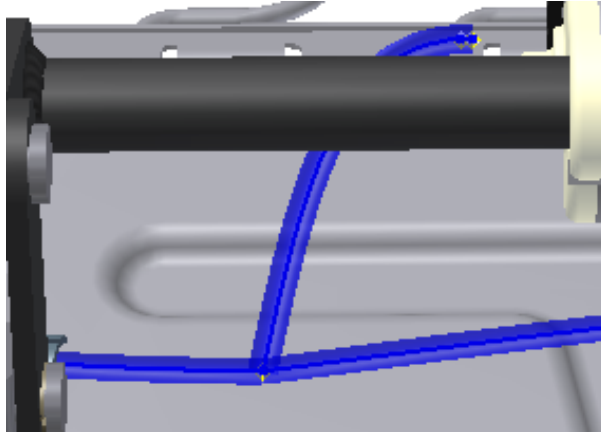

## Add harness segments (continued)



Next, you add a second segment. This segment begins in the same location as the previous segment. Because you selected Continue from the context menu, Create Segment is still active and ready to create another segment.

- 1 Select the segment point that you added previously.

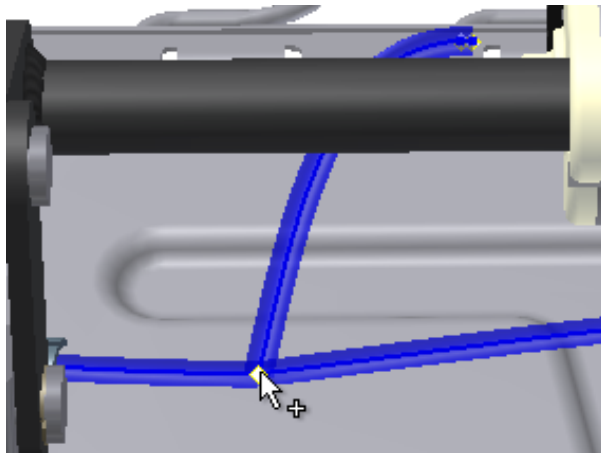

2 Select the existing work point.

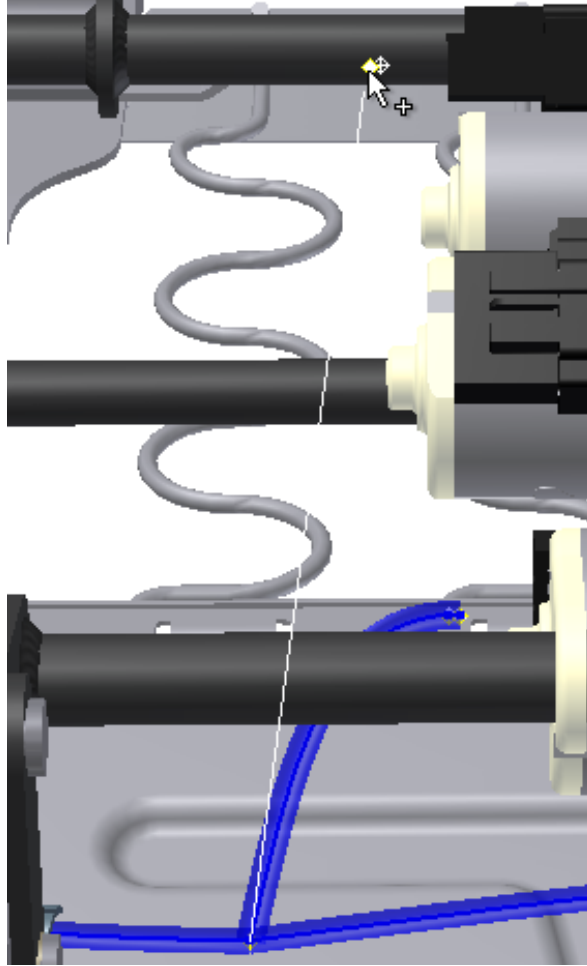

3 Select the other work point.

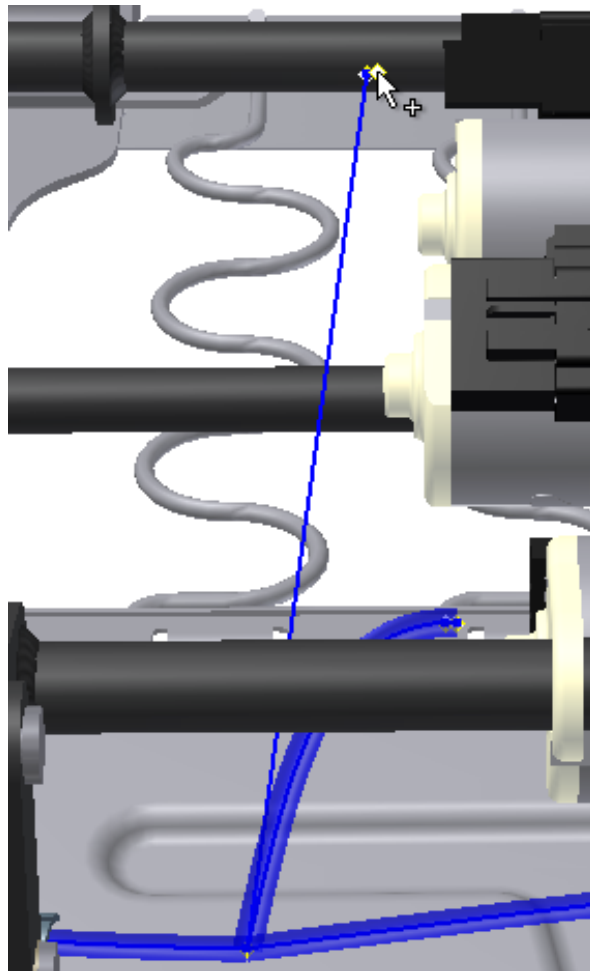

- 4 Right-click, and select **Finish**. The segment is created.

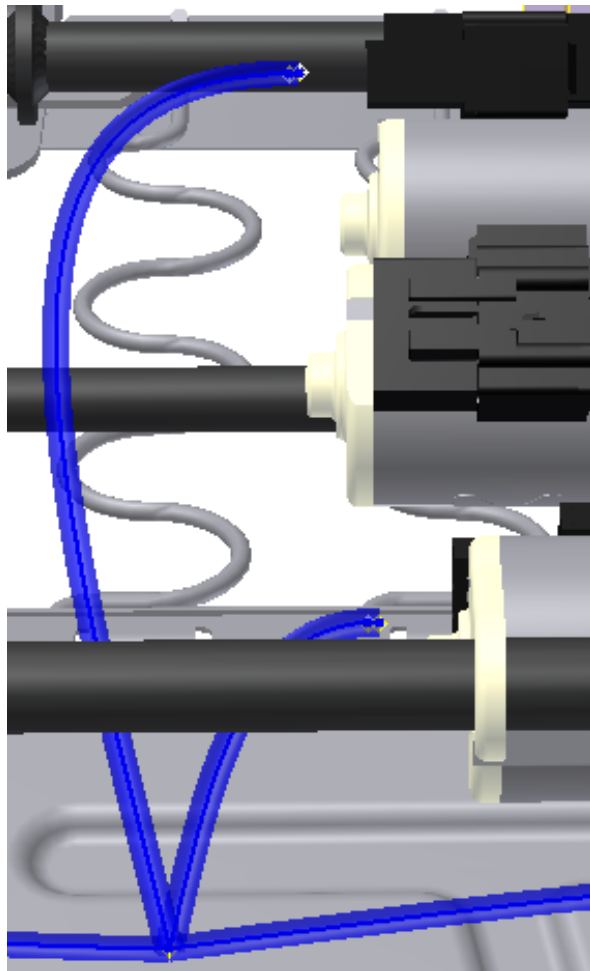

## Import the AutoCAD Electrical data



Apply the AutoCAD Electrical data to the Inventor 3D model.



- 1 Select **Cable and Harness** ► **Manage** ► **Import Harness Data**.
- 2 Click the Browse button next to the Harness Data File field. Select **driverseat\_from\_ace.xml** you exported from AutoCAD Electrical in the *Select Wire List Data File* dialog box. Click **Open**.

---

**NOTE** If you do not have AutoCAD Electrical, you can now use **driverseat\_from\_ace.xml** provided in *Tutorial Files\Automotive\XML\_delivered*.

---

- 3 Click **OK** in the *Import Harness Data* dialog box.

## Issues



The browser nodes in the *Imported Harness Data* dialog box contain the electrical components and wires imported from AutoCAD Electrical.

- Click Filter  in the *Imported Harness Data* dialog box, and then select **Show Issues Only**.

Only items with issues display in the dialog box. The items are identified by



the Issue icon. There are many issues, because the Inventor sample assembly does not contain many of the components contained in the AutoCAD Electrical drawing as reflected in *driverseat\_from\_ace.xml*. Many of the RefDes in AutoCAD Electrical do not have a matching RefDes in Inventor. The absence of various components and RefDes also means that connecting wires also have issues. The missing RefDes do not prevent you from successfully completing the exercise. This scenario is a reflection of a real-world design process in which data may be missing or incomplete but is acceptable for a given point in the workflow.

Scroll to the top of the item list, then right-click **PJ2**, and select **Issue Description**.

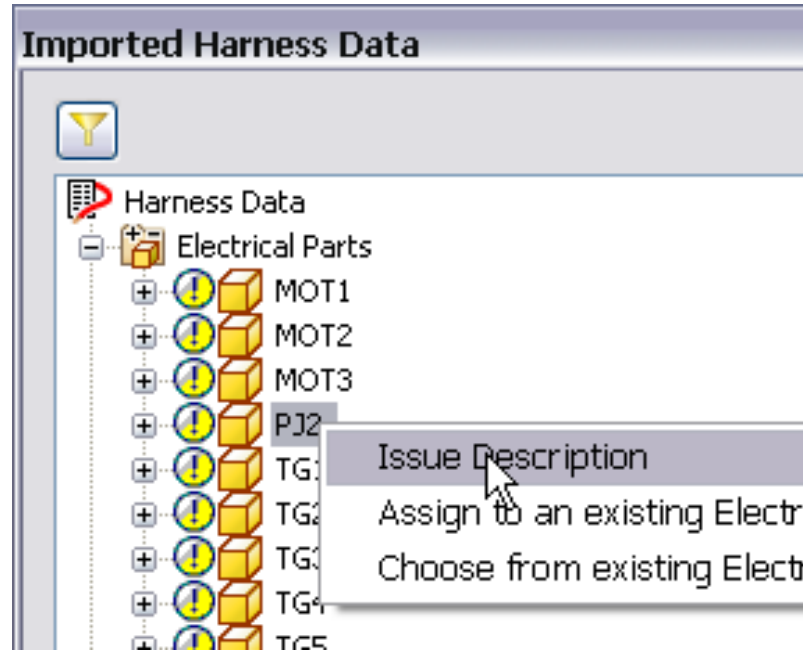

The issue description describes the problem and offers solutions. Review the information, and then close the issue description.

---

**TIP** Click the Help button in the *Imported Harness Data* dialog box to open a reference topic that describes various elements and features in the dialog box.

---

Next, you use functionality on the same context menu to assign the missing RefDes.

## Assign missing RefDes



- 1 Right-click **PJ2** and select **Assign to an existing Electrical Part**.

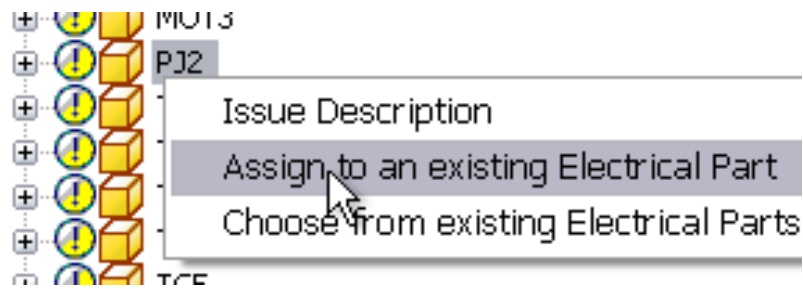

With reference to the AutoCAD Electrical drawing, *P12* is the RefDes specified for the connector that connects to the motor MOT2, the motor for horizontal adjustment.

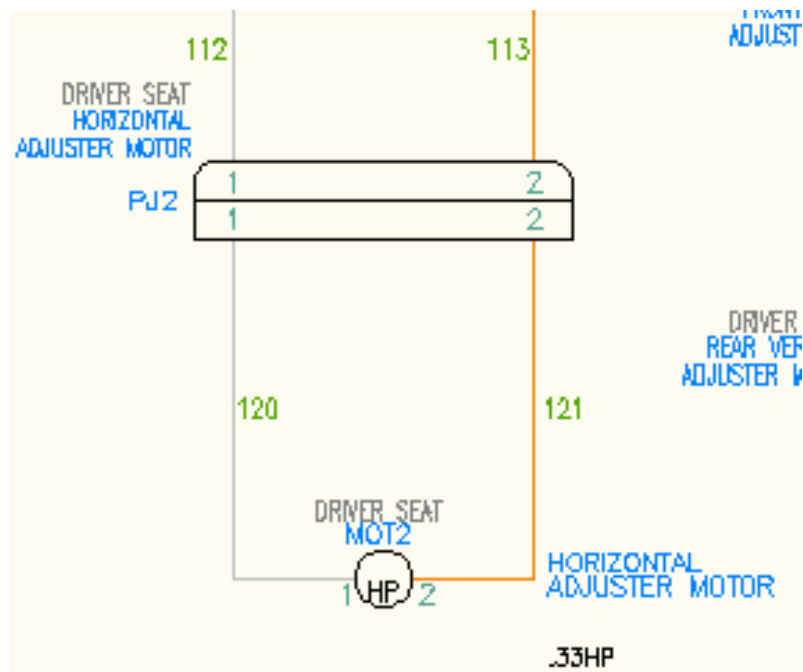

- 2 Pause the cursor over the connector occurrence **900575:2** in the graphics window, and note the tooltip.



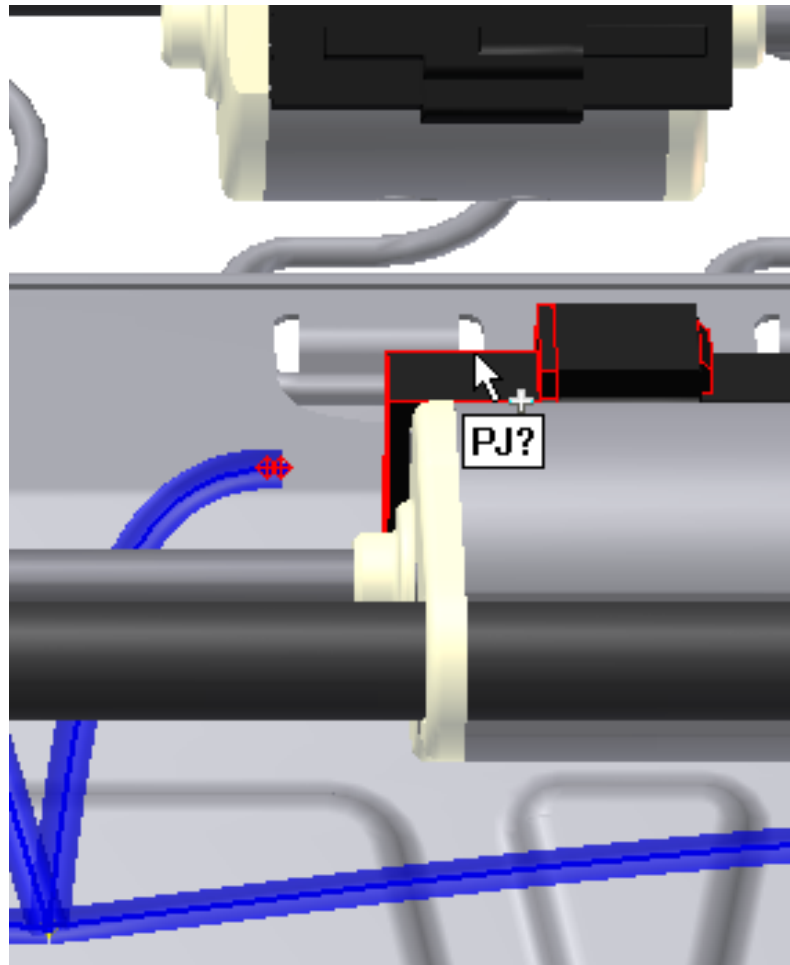

You can select the occurrence in the browser; however, when you use the graphics window, Inventor displays a tooltip. The tooltip shows the RefDes for that component. The question mark (?) indicates that the RefDes is not yet assigned.

- 3 Select the connector.
- 4 Click **OK** in the *Select Electrical Part* dialog box.
- 5 The RefDes specified in AutoCAD Electrical is assigned to the Inventor connector, and the issue associated with *PJ2* is removed. Because the

dialog filter is set to show only items with issues, *PJ2* is not included in the list.

## Finish the Import



Next, you finish the import operation.

- 1 Click **OK** in the *Imported Harness Data* dialog box.
- 2 Close the message dialog box. For this exercise, accept the remaining issues without making further changes.

The data from AutoCAD Electrical is imported. You should see eight imported wires in the graphics window and in the browser.

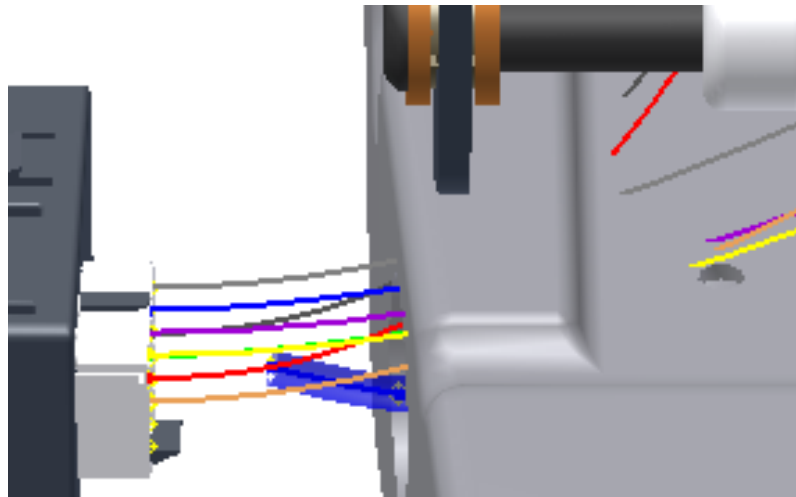

## Route the wires into the harness segments



- 1 Select **Cable and Harness** ► **Route** ► **Automatic Route**.
- 2 Select the **All Unrouted Wires** option. The *Selected* field in the dialog box indicates eight wires are selected.
- 3 Click **OK**. The wires are routed into the segments.

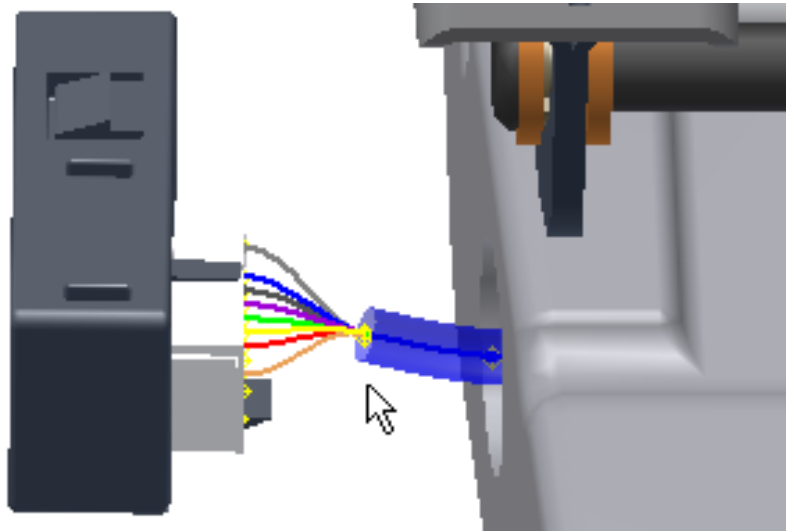

- 4 Select **Cable and Harness** ► **Exit** ► **Finish Cable and Harness**.  
Save the assembly.



This exercise completes the 2D to 3D portion of the tutorial.

## Part 2: 3D to 2D



In this part of the tutorial, you learn how to reverse the workflow and export electrical data from Inventor to AutoCAD Electrical.

### Add a new connector

- 1 Place an occurrence of the connector **900356.ipt**. Place the occurrence as shown.

**TIP** Drag one of the existing occurrences from the browser into the graphics window to create another occurrence, instead of using the Place command.

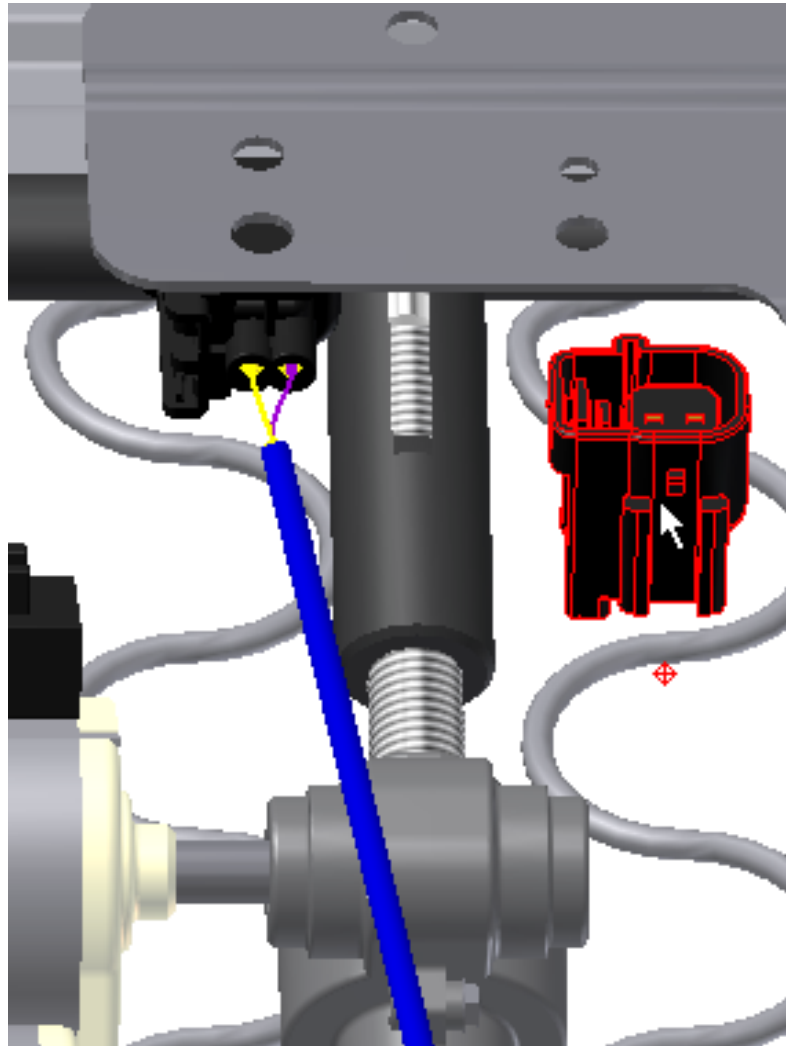

- 2 From the Position panel of the Assemble tab, use **Grip Snap** or **Move** and **Rotate** to approximate the position of the connector. Face the pins on the connector toward the front of the seat.

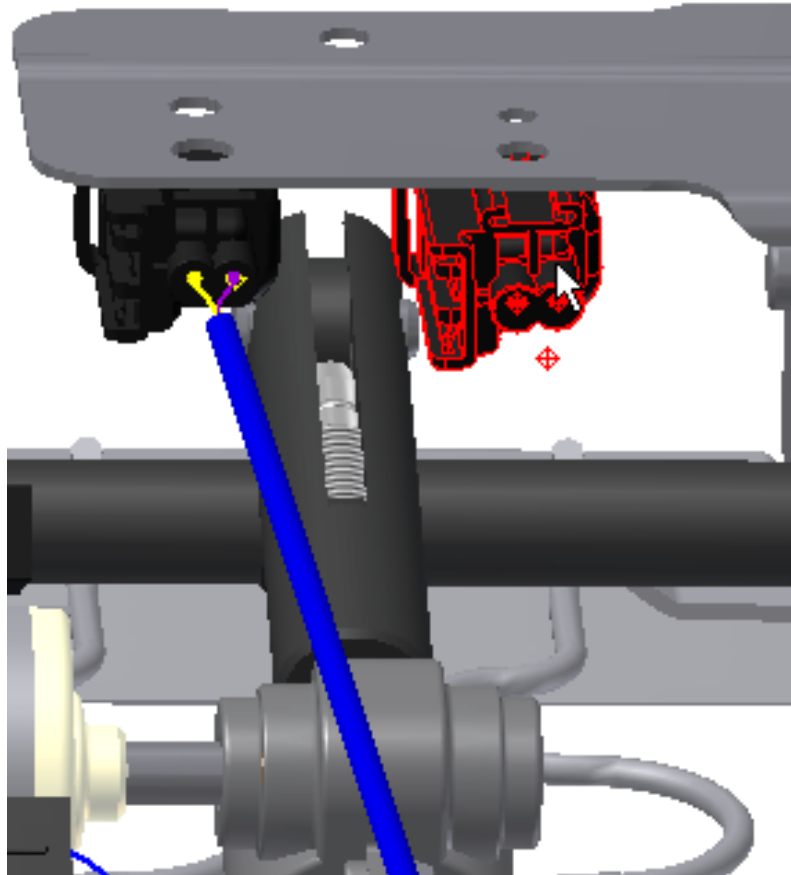

Normally you use assembly constraints to position and constrain the component, but it is not necessary for this exercise.

## Create wires



- 1 In the browser, double-click **Harness1** to edit the harness. Edit the harness assembly - not the part.
- 2 Select **Cable and Harness** ► **Create** ► **Create Wire**.
- 3 Select the pins on the connectors, as shown in the following image. The identification for the first selected pin is **PJ4 Pin 7**.

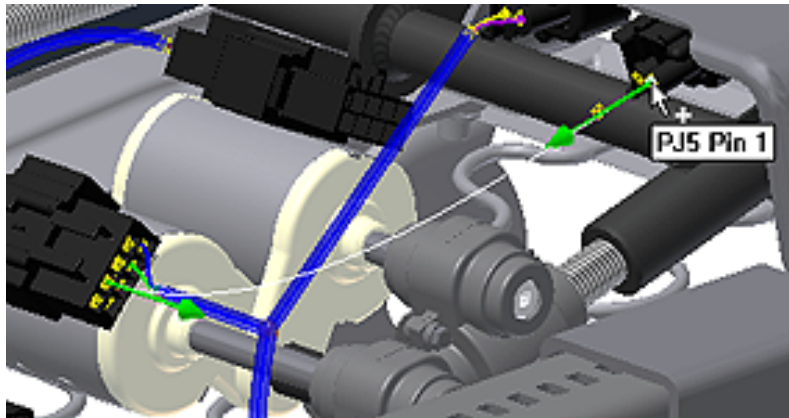

Before you apply the selections, use the *Create Wire* dialog box to specify **Wire ID**, **Category**, **Name** and other properties for the wire.

- 4 Specify the following settings:
  - **Wire ID** - 125
  - **Category** - Belden
  - **Name** - 9916-RED
- 5 Click **Apply** to create the first wire.

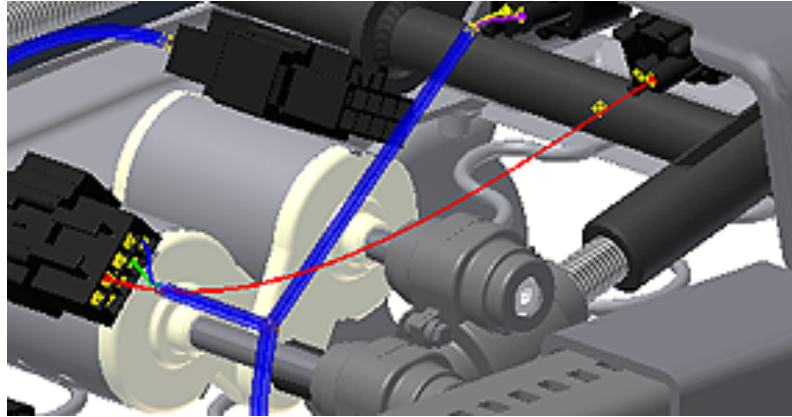

## Create Wires (continued)



- 1 Select the pins on the connectors for the second wire. The identification for the first selected pin is **PJ4 Pin 8**.

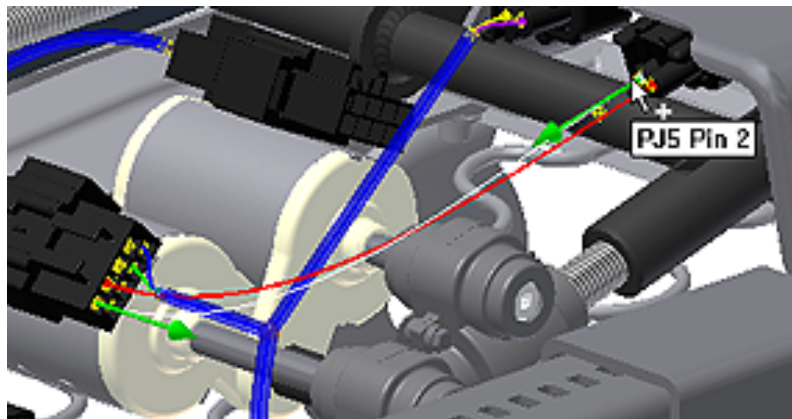

- 2 Specify the following settings in the *Create Wire* dialog box:
  - Wire ID - 126

- **Category - Belden**

- **Name - 9916-ORG**

3 Click **Apply**. Alternatively, right-click and select **Apply**.

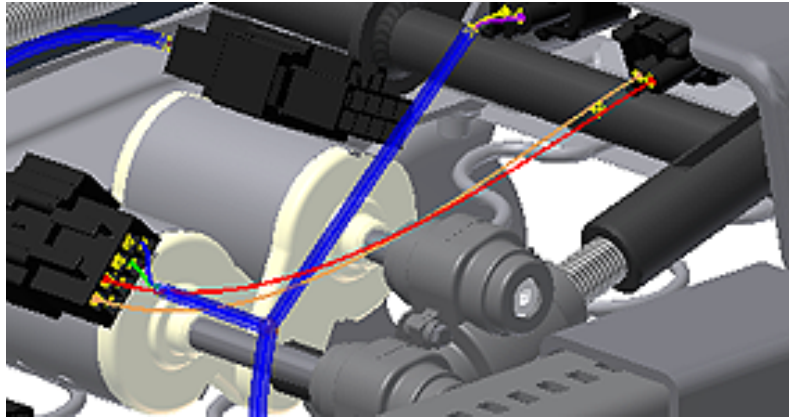

4 Cancel the *Create Wire* dialog box.

## Route wires



- Use **Automatic Route** as you did previously to route the wires into the segments.



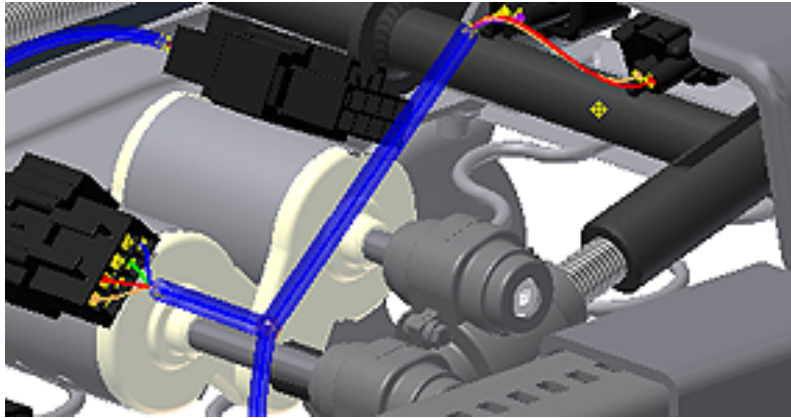

Save the file.

## Export to XML



Next, you export the electrical data contained in your Inventor digital prototype to an XML file. You use this XML file to import the data into AutoCAD Electrical.



- 1 Select **Cable and Harness** ► **Manage** ► **Export Harness Data**.
- 2 Name the file **driveseat\_from\_inv.xml**, and save to the same directory you used for the previous XML file. Dismiss the *Cable and Harness* message dialog box.

## Import the Inventor data



Now, you apply the added connector and wires to the 2D model.

Switch to AutoCAD Electrical.

- 1 Click Schematic tab ► Insert Component panel ► Insert Connector



drop-down ► Insert Connector (From List).

- 2 Select **driverseat\_from\_inv.xml**. Click **Open**.

**NOTE** If you do not have Inventor, you can now use **driverseat\_from\_inv.xml** provided in the folder specified on the Introduction page.

- 3 The connector you added in Inventor is listed in the *Connector Selection* dialog box. Select the row for the connector.

on	Tag	Total Pins	Wired Pin	Description
SEAT	PJ5	2	2	REAR VERTICAL
SEAT	PJ3	8	2	POWER FOR SEAT
SEAT	PJ1	12	8	POWER SEAT
SEAT	PJ2	8	2	HORIZONTAL
SEAT	PJ4	8	4	FRONT VERTICAL
	PJ5:1	2	2	900356:2

- 4 At the bottom of the dialog box, click **Details**.
- 5 On the connector display menu, click **Horizontal**.  
The display in the dialog box switches to horizontal.

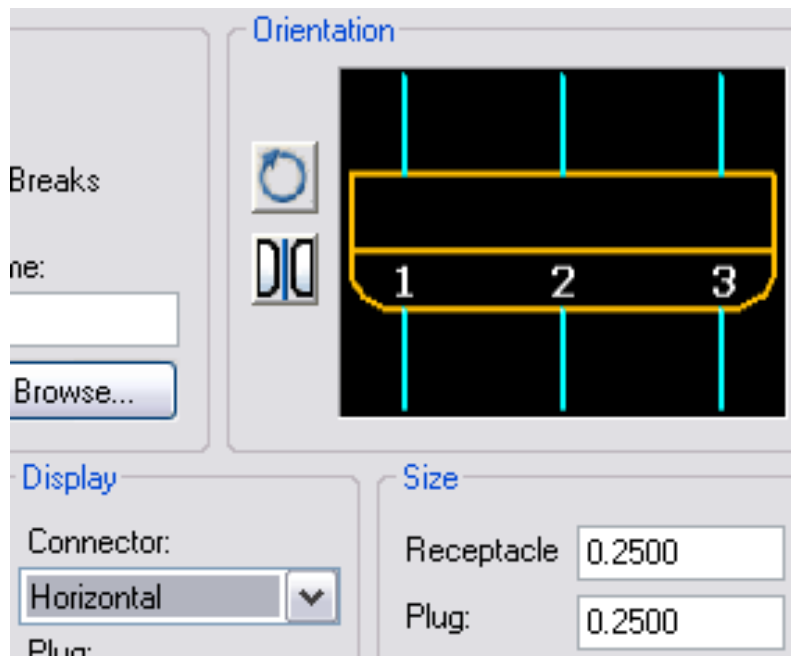

- 6 Click **Insert**.
- 7 Place the connector to the right of the power seat main switch.

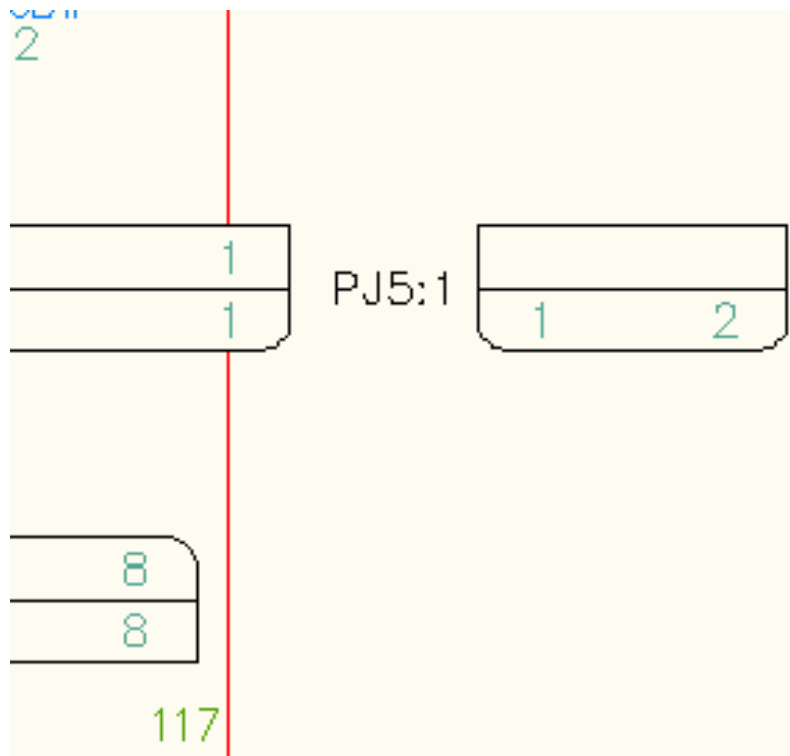

- 8 In the *Connector Selection* dialog box, click **Wire It**. AutoCAD Electrical connects the pins as you specified in Inventor.

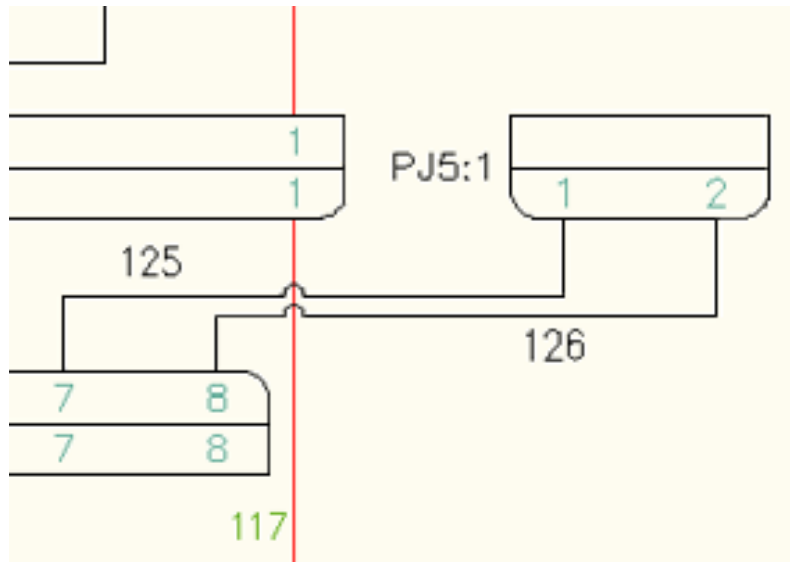

You completed the tutorial.

## Summary



In this tutorial, you used interoperability between AutoCAD Electrical and Inventor Professional or Inventor Routed Systems to develop your digital prototypes. This tutorial showed you how you can:

- Define electrical data in AutoCAD Electrical and then apply that data to the related Inventor 3D prototype.
- Define electrical data in the Inventor 3D prototype and then apply that data to the related AutoCAD Electrical drawing.

This tutorial was meant to provide many details but also serve as an overview of a particular workflow. For further details, information, and options, see the related Help topics contained in AutoCAD Electrical and Inventor.

## Set up peer-to-peer component relationships

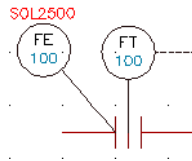

The following example has a valve representation on an instrument drawing, FE100, and its equivalent on the electrical schematic, SOL2500. They are the same physical device, but carry different tags based on the drawing discipline in which they appear. Though each device is represented as a parent symbol, you can set up a peer-to-peer relationship between them so that the electrical tag name of the schematic automatically cross-references to the instrument drawing, and the tag cross-references of the instrument bubble to the tag of the schematic.

The instrument bubble symbol is set up with an optional split tag. Instead of a single TAG1 attribute, it has two tags: TAG1 PART1 and TAG1 PART2. The instrument bubble is also set up as a normal AutoCAD Electrical parent schematic symbol without the wire connection points. It includes two extra attributes beyond what a normal parent symbol carries:

- WDTAGALT - carries a copy of the schematic TAG1 value of the symbol.
- WDTYPE - an invisible attribute with a nonblank value indicating the component category. Example: "PI" for P&ID, "PN" for pneumatic, or "HY" for hydraulic

The schematic parent solenoid symbol includes just one extra attribute: WDTAGALT carries a copy of the instrument value of the bubble.

Your drawings must be part of the active AutoCAD Electrical project so that the WDTAGALT value on the instrument drawing is automatically updated when you edit the schematic parent tag name and vice versa. Using AutoCAD Electrical SURF on one automatically includes the other in the surf pick window.

- 1 Open the Project Manager.
- 2 Open the project containing the instrument and schematic drawings.
- 3 On the Project Manager, double-click the schematic drawing to open it.
- 4 Zoom in so that your schematic symbol is visible.



- 5 On the Project Manager, double-click the instrument drawing to open it.
- 6 Zoom in so that your valve representation is visible.

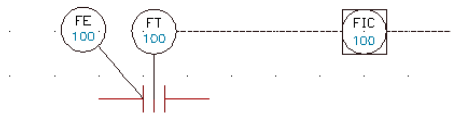

- 7 On the Project Manager, right-click the project name, and select Properties.
- 8 On the Project Properties, Cross-references dialog box, Cross-reference Options section, select Peer-to-Peer.
- 9 Click OK.
- 10 Right-click the schematic symbol to edit in the drawing (in this case, SOL2500).
- 11 Select Edit Component from the context menu.
- 12 On the Insert/Edit Component dialog box, click Tags Used: Schematic.



- 13 Select Show all components for all families.  
The tag values from the other symbol appear in the list.
- 14 Select the valve representation (in this case, FE100) with a family code of IN (for instrument).
- 15 Click Copy Tag.
- 16 On the Copy Tag dialog box, click WDTAGALT.
- 17 On the Insert/Edit Component dialog box, click Show/Edit Miscellaneous.
- 18 Verify that the WDTAGALT value lists the TAG1 value of the valve (in this case, FE100) and click OK.
- 19 On the Insert/Edit Component dialog box, click OK.
- 20 On the Update Other Drawings dialog box, click Now to update the drawing.  
The WDTAGALT value of the schematic symbol is automatically updated and the TAG1 value of the valve (or TAG1 PART1/TAG1 PART2 combined value) appears next to the symbol in the drawing.



The WDTAGALT value of the valve is automatically updated and the TAG1 value of the schematic symbol appears next to the valve in the drawing.

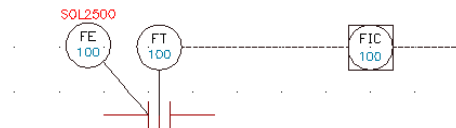

## Create automated pin assignments

AutoCAD Electrical consults a Pin List database when a part number is added or an existing part number is changed on a parent schematic symbol. If AutoCAD Electrical finds a match on the part number's MFG, CAT, and optional ASSYCODE values (which ties to the catalog number to make unique parts) in this database table, then the associated contact count and pin number information is retrieved and placed on the parent schematic component.

Any device can have pins assigned to it, but common components that carry pin assignments are relays, motor starters, and connectors. Pins are used for:

- Error checking
- Accurate connection information
- Providing correct connections

You can expand the Pin List database table as needed. Many users have difficulty creating their own database entries so the following procedures simplify this procedure for you.

### **Basic workflow**

Pin lists are directly associated to catalog numbers and therefore are not applied to a component symbol until the catalog number has been assigned. You can use wildcards inside the Pin List database to find the catalog number to apply a single pin list to multiple symbols. The basic workflow for pin numbers being assigned to a symbol is as follows:

- Insert a component.
- On the Insert/Edit Component dialog box, assign a catalog number.
- Pin List database is queried.
- Coil pins are applied to the parent symbol's terminal attributes.
- The Pin List is applied to the parent symbol as xdata or attributes.  
If the pin numbers are assigned as xdata, there is not a PINLIST attribute since the pin assignment comes from the pin list table.

### **Setting up COILPINS**

The COILPINS column in the Pin List database specifies the terminal pin numbers for a coil or parent symbol of a component. This is generally two pin numbers separated by a comma (such as K1,K2). When a component calls for additional pin assignments on the parent, you can continue the list with each value separated by commas. These values are applied to the TERM01 and TERM02 attributes respectively on the parent symbol.

If you set COILPINS = "K1,K2;" then pins K1/K2 are assigned to the parent symbol of a component.

In the example below, TERM01 = K1 and TERM02 = K2.

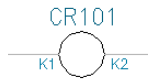

### Setting up COILPINS for two wired devices

The automatic pin list look-up and assignment at component insertion time is not limited to relay devices as shown in the example above. You can encode two wire devices like pilot lights or proximity switches into the database file. Insert the Manufacturer and Catalog numbers and fill in the COILPINS field with the terminal pin numbers. Leave the PINLIST field blank. Now, when you insert one of these devices and do a catalog lookup and part number selection, AutoCAD Electrical quickly looks for a MFG/CAT match in the pin list database. On a match, AutoCAD Electrical pulls out the device's coil pin numbers and inserts them in the newly inserted device.

### Setting up a PINLIST

The PINLIST column in the Pin List database specifies the contact types and their respective pin numbers. A two terminal contact has three elements in this format: contact type, terminal pin, terminal pin. Each PINLIST value can have up to 256 characters. Use a value 0-5 to specify the contact type, where:

- 0 = convertible contact
- 1 = N.O.
- 2 = N.C.
- 3 = Form-C (NO/NC pair)
- 4 = multiple-pole terminal strips or undefined type
- 5 = multiple-pin or stacked terminals

If you set PINLIST = "0,13,14;0,23,24" then 0= contact type, 13 (or 23)= TERM01, and 14 (or 24)= TERM02.

If you set PINLIST = "0,13,14,\*prompt," "\*"prompt" adds a description label. This optional label is always the last element of the list and is preceded by an asterisk character (if the asterisk is left out, the comment is interpreted as another pin number).

To view or manually edit the PINLIST values, select Edit Component, and then click NO/NC Setup on the Insert/Edit Component dialog box.

### Setting up PEER\_COILPINS and PEER\_PINLIST

The PEER\_ fields in the Pin List database specify pin list assignments for a single part number with two parent devices. You set up the second coil's coil pins and pin list data in the PEER\_COILPINS and PEER\_PINLIST fields for the common part number. This is commonly used for setting up forward and reversing starters or latching and unlatching relays. You apply the pins to the forward (latching) relay, and then apply the peer pins to the reversing (unlatching) relay.

To split the pin list data between two peer coil symbols:

- 1 Insert the first coil symbol and make the catalog look-up selection.  
The COILPINS and PINLIST data is found and applied to the coil symbol. Any defined peer coil and pinlist data is also saved on the symbol as invisible xdata.
- 2 Insert the second coil symbol but do not make a catalog assignment.
- 3 In the Insert/Edit Component dialog box, click NO/NC Setup.
- 4 Click Pick.
- 5 Select the first coil symbol.  
The saved peer pinlist data is moved from the first symbol over to this peer symbol. Child contacts can now be auto-annotated with the selected coil's available pin list information and max NO/NC count tracked on a per-coil basis.

## Set up AutoCAD Electrical for multiple users

You can manually move any shared files to a new central location after installation by using normal Microsoft Windows operations to cut or copy and paste from their local location to a central shared location. These shared files are located by AutoCAD Electrical as long as they are placed in the AutoCAD Electrical defined path (such as in the project's subdirectory), the path given by the AutoCAD Electrical environment variable, or AutoCAD search paths.

---

**NOTE** We recommend that you create a backup of your information in another location and remove the shared data from your local drive to ensure that the data is being located correctly.

---

## Shared files

The following shared files can be pasted from your local machine to a shared location. The table lists the file names, default location, and any WD.ENV file lines that must be modified.

The main executables and static support files are located under *C:\Program Files [(x86)]\Autodesk\Acade {version}\*. The user-modifiable support files and database content are found under

**Windows XP:** C:\Documents and Settings\{username}\Application Data\Autodesk\AutoCAD Electrical {version}\{release}\{country code}\

### Windows Vista, Windows 7:

C:\Users\{username}\AppData\Roaming\Autodesk\AutoCAD Electrical {version}\{release}\{country code}\

---

**NOTE** It is not required that you share these files, but sharing makes it easier for multiple users to work with projects in AutoCAD Electrical.

---

## Databases

default\_cat.mdb, footprint\_lookup.mdb, schematic\_lookup.mdb, wd\_lang1.mdb, wd\_picklist.mdb, wddinrl.xls, ace\_electrical\_standards.mdb

**Windows XP:** C:\Documents and Settings\{username}\My Documents\Acade {version}\AeData\Catalogs

**Windows Vista, Windows 7:** C:\Users\{username}\Documents\Acade {version}\AeData\Catalogs

### WD.ENV file edit:

Original path: WD\_CAT,%WD\_DIR%/catalogs/,AE catalog file path

Edited path: WD\_CAT,N:Electrical/Shared\_Files/Catalogs/,AE catalog file path

---

**NOTE** These files must be kept in the same location since the program locates them according to the same WD.ENV file entry.

---

## Circuit Builder Spreadsheet

ace\_circuit\_builder.xls

**Windows XP:** C:\Documents and Settings\All Users\Documents\Autodesk\AcadE {version}\Support\

**Windows Vista, Windows 7:** C:\Users\Public\Documents\Autodesk\AcadE {version}\Support\

**WD.ENV file edit:**

Original file name: WD\_CIRCBUILDER\_FNAM,"ace\_circuit\_builder.xls",Circuit Builder spreadsheet file name  
Edited name: WD\_CIRCBUILDER\_FNAM,"my\_ace\_circuit\_builder.xls",Circuit Builder spreadsheet file name

**Symbol libraries**

jic1, jic125, iec2, iec4, jis2, gb2, panel, pneu\_iso125

**Windows XP:** C:\Documents and Settings\All Users\Documents\Autodesk\Acade {version}\Libs

**Windows Vista, Windows 7:** C:\Users\Public\Documents\Autodesk\Acade {version}\Libs

---

**NOTE** The symbol library path is stored with each project in its .wdp file and must be modified.

---

**AutoCAD Electrical icon menu (Insert Component menus)**

ACE\_AS\_MENU.DAT, ACE\_GB\_MENU.DAT,  
ACE\_HYD\_MENU.DAT, ACE\_IEC\_MENU.DAT,  
ACE\_JIC\_MENU.DAT, ACE\_JIS\_MENU.DAT, ACE\_PANEL\_MENU.DAT, ACE\_PID\_MENU.DAT,  
ACE\_PNEU\_MENU.DAT, WD\_ABECAD.DAT

**Windows XP:** C:\Documents and Settings\{username}\Application Data\Autodesk\AutoCAD Electrical {version}\{release}\{country code}\Support

**Windows Vista, Windows 7:** C:\Users\{username}\AppData\Roaming\Autodesk\AutoCAD Electrical {version}\{release}\{country code}\Support

---

**NOTE** The menu path is stored with each project in its .wdp file and must be modified.

---

**Slide images for AutoCAD Electrical menus**

ACE\_GB.slb, ACE\_GB.dll, ACE\_JIS.slb, ACE\_JIS.dll, ace\_as.slb, ace\_as.dll, ace\_hyd.slb, ace\_hyd.dll, ace\_pid.slb, ace\_pid.dll, bb.slb, iec1.slb, iec.dll, loc2.slb, pn0.slb, pn0.dll, pn1.slb, pn1.dll, pn2.slb, pn2.dll, pn3.slb, pn3.dll, pnl2.slb, pnl2.dll, pnl.slb, pnl.dll, s1.slb, s1.dll, s2.slb, s2.dll, Ww.slb

**Windows XP:** C:\Documents and Settings\{username}\Application Data\Autodesk\AutoCAD Electrical {version}\{release}\{country code}\Support

**Windows Vista, Windows 7:** C:\Users\{username}\AppData\Roaming\Autodesk\AutoCAD Electrical {version}\{release}\{country code}\Support

S\_LDPC.SLB, WD\_LOCAL.SLB, WDSIG.SLB, WDSIG\_1.SLB, gepb.slb  
C:\Program Files [(x86)]\Autodesk\Acade {version}\Support

**WD.ENV file edit:**

Original path: \*WD\_SLB,x:some path/, to override path pointing to ".slb" slide lib support files

Edited path: WD\_SLB,N:/Electrical/Shared\_Files/Slides/, to override path pointing to ".slb" slide lib support files

---

**NOTE** For the path in the .env file to be recognized, the asterisk (\*) in front of the line must be removed. These slide files may be relocated using this path, or they can just be placed in the same location as the menu files.

---

**PLC database/images**

Content of PLC folder (ace\_plc.mdb and bitmap files)

**Windows XP:** C:\Documents and Settings\{username}\My Documents\Acade {version}\AeData\PLC

**Windows Vista, Windows 7:** C:\Users\{username}\Documents\Acade {version}\AeData\PLC

---

**NOTE** These files must be in a location that is specified as an AutoCAD Support path. They can be placed in a location that is already defined as being a support path, or you can add a new support path pointing to this location.

---

**Description selections**

wd\_desc.wdd

**Windows XP:** C:\Documents and Settings\{username}\Application Data\Autodesk\AutoCAD Electrical {version}\{release}\{country code}\Support

**Windows Vista, Windows 7:** C:\Users\{username}\AppData\Roaming\Autodesk\AutoCAD Electrical {version}\{release}\{country code}\Support

---

**NOTE** These files must be in a location that is specified as an AutoCAD Support path. They can be placed in a location that is already defined as being a support path, or you can add a new support path pointing to this location.

---

**Installation code selection list**

default.inst

Optional file, does not exist by default. To create this file in Notepad, create a file with the project name and an .inst extension (or use default.inst) and save to an AutoCAD Support path so the program can find it.

---

**NOTE** These files must be in a location that is specified as an AutoCAD Support path. They can be placed in a location that is already defined as being a support path, or you can add a new support path pointing to this location.

---

**Location code selection list**

default.loc

Optional file, does not exist by default. To create this file in Notepad, create a file with the project name and a .loc extension (or use default.loc) and save to an AutoCAD Support path so the program can find it.

---

**NOTE** These files must be in a location that is specified as an AutoCAD Support path. They can be placed in a location that is already defined as being a support path, or you can add a new support path pointing to this location.

---

### Using network deployment

You can alternately install AutoCAD Electrical databases, symbol libraries, part footprint files, and support files to a shared network location, so all users can work from a common standard database and simplifying database management and configuration.

To start network deployment, select Network Deployment in the AutoCAD Electrical installation program. Install the Network Installation Wizard (NIW) and run it from the start menu. From the NIW, you can create an image for client installations.

Use the Symbols Libraries, Catalog Database and Support Files dialog box to install these files to a shared network location so that multiple users can work from a common standard symbol library and parts database.



---

**NOTE** You cannot set up network deployment after installing AutoCAD Electrical as a stand-alone program on individual machines.

---

### Referencing icon menus from other menu files

You can also share custom symbols to be accessed by multiple users. The easiest way to do this is to create and link to your own menu file.

You can set up AutoCAD Electrical's icon menuing system so that you can switch back and forth from the default menu file (such as ACE\_JIC\_menu.dat) to your own menu (for example "special\_menu.dat").

- 1 Add a line like this to AutoCAD Electrical's ACE\_JIC\_menu.dat file:  
Special menu\special\_menu.sld\C=(c:wd\_loadmenu  
"special\_menu.dat")(c:wd\_insym\_go2menu 0)
- 2 In your new "special\_menu.dat" file, add this line so you can switch back to AutoCAD Electrical's default menu:  
Default Electrical menu\back2wd.sld\C=(c:wd\_loadmenu  
"ACE\_JIC\_menu.dat")(c:wd\_insym\_go2menu 0)
- 3 In AutoCAD Electrical's default icon menu, select the new entry.  
Your menu immediately appears. When you want to go back to AutoCAD Electrical's default menu, select Default Electrical menu on your own special menu. AutoCAD Electrical immediately switches back to the AutoCAD Electrical default icon menus.

## Show source and destination markers on cable wires

There may be times when you want to show the individual wires of a cable at each end where they connect and yet you want to show the wires coming together to form a single line cable in between the ends. Showing individual wires along the entire run of the cable is too messy or not an option.

You can use the Fan-In/Out command set to do this. The Fan-In/Out command relies on special pairs of source/destination markers plus a special layer for the single line part of the cable representation. This layer is defined in the Define Layers dialog box.

### Setting up layers

- 1 In a blank AutoCAD Electrical drawing,

Click Schematic tab ► Other Tools panel ► Drawing Properties



drop-down ► Drawing Properties.

- 2 On the Alert dialog box, click OK to add the WD\_M block.
- 3 In the Drawing Properties dialog box, click the Style tab.  
You can select the default Fan-In/Out marker style here along with defining the layers for the wires. Notice that the default layer name for fan in/out single line layers is "\_MULTI\_WIRE."
- 4 In the Drawing Properties dialog box, click OK.
- 5 Click the AutoCAD Layer Properties Manager tool.
- 6 In the Layer Properties Manager dialog box, change the color of "\_MULTI\_WIRE" to red and the color of "WIRES" to blue for this example. The color difference illustrates how the feature works.
- 7 In the Layer Properties Manager dialog box, click OK.

### Inserting components

- 1 Click Schematic tab ► Insert Components panel ► Insert Components

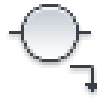

drop-down ► Icon Menu.

- 2 In the Insert Component: JIC Schematic Symbols dialog box, select Push Buttons.
- 3 In the JIC: Push Buttons dialog box, select Push Button N.O.
- 4 Press F9 to turn on SNAP.
- 5 Insert the push button anywhere on the left-hand side of the drawing.
- 6 In the Insert/Edit Component dialog box, click OK-Repeat to insert two more push buttons directly below the first one.
- 7 In the Insert/Edit Component dialog box, click OK after the last push button is inserted on the drawing.
- 8 Repeat to insert three Limit Switches N.O. Insert the limit switches anywhere on the right-hand side of the drawing (slightly below the push buttons you inserted).

PB? 

PB?A 

PB?B 

LS? 

LS?A 

LS?B 

### Adding wires

- 1 Click Schematic tab ► Insert Wires/Wire Numbers panel ► Insert Wires

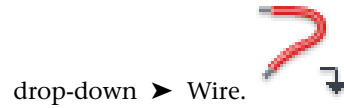

- 2 Add a wire to the top push button. Drag the wire to the right.
- 3 Repeat for the other two push buttons.
- 4 Add a wire to each of the limit switches. Drag the wires to the left.
- 5 Press F9 to turn off SNAP.
- 6 Select all of the wires and verify that they were created on the WIRES layer.

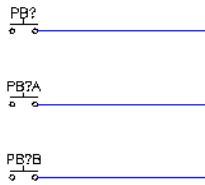

### Adding source and destination markers

- 1 Click Schematic tab ► Insert Wires/Wire Numbers panel ► Signal



Arrows drop-down ► Fan In Source.

- 2 In the Fan In/Out Source dialog box, select Solid as the Source marker style.

- 4 Click the left button to set the wire connection orientation.

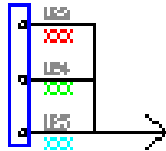

- 5 Select in the middle of the wire that is connected to the top push button.

- 6 In the Signal - Source Code dialog box, enter "cba" as the code and "RED" as the description.

If you enter the color of the wire in the Description field, AutoCAD Electrical reports use this information in the Wire Color field.

- 7 Click OK.

- 8 In the Source/Destination Signal markers (for Fan In/Out) dialog box, click Yes to insert the matching destination marker now.

---

**NOTE** Because the destination wires are nearby, it is easier to insert them right away. If the wires were on another drawing you could wait until later to add the destination markers.

---

- 9 In the Fan-In/Fan-Out Signal Destination dialog box, select Solid as the destination marker style.
- 10 Click the right button to set the wire connection orientation.

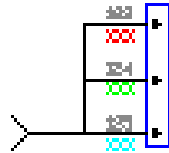

- 11 Select in the middle of the wire connected to the top limit switch. Notice that the wires for both change from blue to red, and the description RED appears on both.

AutoCAD Electrical breaks the wire and changes the appropriate wire piece to the defined layer. When inserting a source marker the wire coming out of the marker changes; when inserting a destination marker, the wire going into the marker changes.

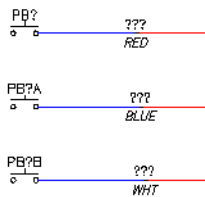

You are prompted to define the next source.

- 12 Repeat for the middle and bottom wires for each group.

For the middle wire: In the Signal - Source Code dialog box, click Use to enter "CBLA-01" as the code and enter "BLUE" as the description.

For the bottom wire: In the Signal - Source Code dialog box, click Use to enter "CBLA-02" as the code and enter "WHT" as the description.

Notice that the wires change from blue to red, and the descriptions BLUE and WHT display on both sets of wires.

13 Press Esc to exit the command.

14 Select all of the wires and verify that they are on the `_MULTI_WIRE` layer.

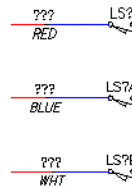
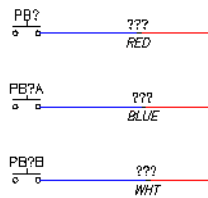

### Creating connecting wires

- 1 At the command line, type L and press Enter.
- 2 Click the end of the uppermost wire and drag down across each of the wires connected to the push buttons. Continue dragging past the push buttons and click.
- 3 Drag your cursor to the right to create a horizontal line, and click.
- 4 Drag down across the ends of the wires connected to the limit switches, ending on the bottom wire and click. Press Enter to create the lines.

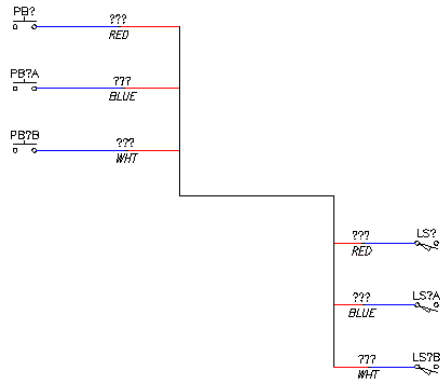

- 5 Type MA at the command prompt to run the AutoCAD MATCHPROP command.
- 6 Click the wire connected to the top limit switch.
- 7 Click each of the lines you just created. The lines change from black to red since they are taking on the properties of the wire you selected.

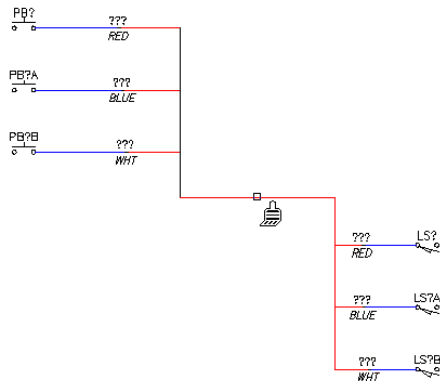

- Press Enter to exit the command.

### Adding cable markers

At this point, you have established the link between the push buttons and the limit switches. You can now include a cable marker identifier that is associated with these wire connections in various wire and cable reports.

- 1 Click Schematic tab ► Insert Wires/Wire Numbers panel ► Cable

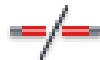

Markers drop-down ► Cable Markers.

- 2 Select to insert a cable marker.
- 3 Insert the cable marker on the horizontal line.
- 4 In the Insert/Edit Cable Marker (Parent wire) dialog box, click Catalog Data Lookup.
- 5 In the Parts Catalog dialog box, select the 3 conductor (second item in list) and click OK.
- 6 In the Insert/Edit Cable Marker (Parent wire) dialog box, delete the wire color/id value (BLK), and click OK.
- 7 In the Insert Some Child Components dialog box, click Close.

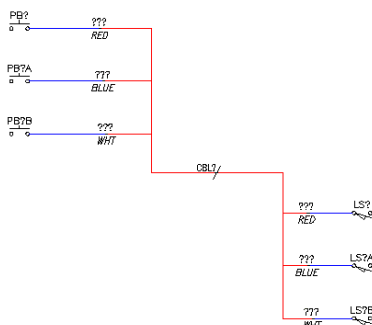

## Use the PLC Database File Editor

AutoCAD Electrical can generate any of hundreds of different PLC I/O modules on demand, in a variety of different graphical styles, all without a single, complete I/O module library symbol resident on the system. Modules automatically adapt to the underlying ladder rung spacing, whatever that value might be, and can even be stretched or broken into two or more pieces at insertion time. This is all possible because AutoCAD Electrical generates PLC I/O modules via a parametric generation technique driven by a PLC database (ACE\_PLC.MDB).



## Creating new PLC modules

By default, when creating a PLC module the PLC Database File Editor lists as many blank field Terminal Types as there are terminals defined in the New Module dialog box.

- 1 Click Schematic tab ➤ Other Tools panel ➤  ➤ Database Editors drop-down ➤ PLC Database File Editor. 

- 2 Click the PLC Database File Editor tool.
- 3 In the PLC Database File Editor dialog box, highlight PLCs in the PLC selection list and click New Module.
- 4 In the New Module dialog box, specify the following:
  - Manufacturer: Allen-Bradley
  - Series: 1746
  - Series Type: Discrete Input
  - Code (Catalog Number): 1746-IA9
  - Terminals: 9
  - Addressable Points: 8
- 5 Click OK.

	Terminal Type	Show
1	Blank	Always
2	Blank	Always
3	Blank	Always
4	Blank	Always
5	Blank	Always
6	Blank	Always
7	Blank	Always
8	Blank	Always
9	Blank	Always

You now have a new blank input module with nine terminals and eight addressable I/O points. You now need to define some information for each terminal in the module, the most important being what symbols AutoCAD Electrical should stack together to build the module. Usually the top-most symbol for the module is a little different from the rest so

that it can carry some basic information for the module that only needs to occur once in the final symbol.

### Assigning Terminal Types

- 1 In the PLC Database File Editor dialog box, right-click Terminal Type 1 and select Edit Terminal from the context menu.

The Select Terminal Information dialog box appears. There are 3 categories for top symbols: Top Input, Top Output, and Top Terminal. Top Input and Top Output are addressable terminals, while the Top Terminal category consists of non-addressable terminals.

- 2 In the Select Terminal Information dialog box, select Top Input.

The available terminals for that category appear along with any recently used terminals. Each terminal shown is slightly different. It may have an input wire connection terminal or have terminals for both input and output, or it may not have a wire connection.

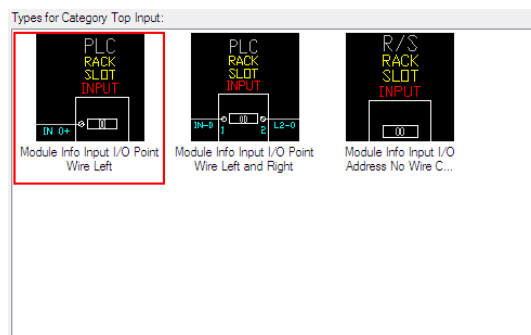

- 3 Select to use Module Info Input I/O Point Wire Left by selecting the picture and then click OK.

The selected terminal is assigned to the Terminal Type in the PLC Database File Editor dialog box. AutoCAD Electrical looks at the block to see what attributes come in when the block is inserted. Some of the attributes come in with predefined values that can be overwritten. You will see these predefined values in the grid below the terminal type list.

- 4 In the PLC Database File Editor dialog box, multiple-select the next seven terminals, right-click, and select Edit Terminal.

---

**NOTE** You can select multiple fields to edit at the same time by dragging your mouse across contiguous fields or by holding down the Control key while selecting non-contiguous fields.

---

- In the Select Terminal Information dialog box, select the Input category and look at the available terminals.

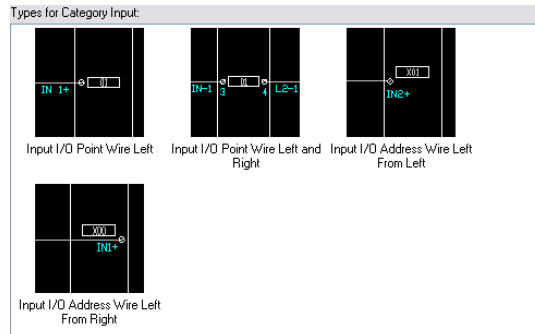

- Select the Input I/O Point Wire Left terminal and click OK. All seven terminals are assigned at the same time.

	Terminal Type	Show
1	Module Info Input I/O Point Wire Left	Always
2	Input I/O Point Wire Left	Always
3	Input I/O Point Wire Left	Always
4	Input I/O Point Wire Left	Always
5	Input I/O Point Wire Left	Always
6	Input I/O Point Wire Left	Always
7	Input I/O Point Wire Left	Always
8	Blank	Always
9	Blank	Always

- In the PLC Database File Editor dialog box, right-click on the last terminal and select Edit Terminal.
- In the Select Terminal Information dialog box, select the Terminal category.
- Click the Terminal Point Wire Right terminal and click OK.

As an alternative to the Select Terminal Information dialog box, you can use the drop-down list of predetermined Terminal Types. Click the arrow for the Terminal Type and select from the list of available terminal types.

### Setting additional terminal information

Some modules may have terminals that are not used. When you build your PLC module on an AutoCAD Electrical drawing there is a choice inside the Module Layout dialog box to include unused/extra connections. When this toggle is not selected, all terminal entries marked as "Show: When Including Unused" in the PLC Database File Editor are skipped. When this toggle is selected, all entries marked with "Show: When Excluding Unused" are skipped. This gives flexibility to how a module is represented.

- 1 In the PLC Database File Editor dialog box, make sure all of the terminals are set to Show: Always.
- 2 Make sure all of the terminals are set to Optional Re-prompt: No.  
You can trigger AutoCAD Electrical to prompt for a new beginning address number when the parametric build flips from inputs to outputs or vice versa. On the line where you want AutoCAD Electrical to re-prompt for a new output address, select Output. If you want a re-prompt for a new input address, select Input from the list.
- 3 If you want a prompt for an automatic break in the PLC module, select the toggle in the Break After column.
- 4 If you want to override the rung spacing for the I/O and wire connection point spacing, enter a value in the Spacing Factor column.  
When AutoCAD Electrical generates a PLC module, it uses the current rung spacing for I/O and wire connection point spacing. When a Spacing Factor is specified, AutoCAD Electrical sees this spacing factor value on any terminal type I/O point or wire connection entry line, it uses a factor of the rung spacing. For example, a 2 for a given entry inserts this point down two times the rung spacing instead of a full rung spacing. A value of 1.5 inserts the point down an extra half rung spacing. A value of 0.0 puts the particular I/O point at the same location as the preceding one.

### Modifying the terminal box dimensions

The Style Box Dimensions dialog box defines the module box dimensions (such as the offset values and line properties) based upon the style number used when the PLC was created.

- 1 In the PLC Database File Editor dialog box, click Style Box Dimensions.
- 2 Select Style 2 as the graphic style for your plc module. Styles 1-5 are predefined, styles 6-9 may be user-defined. Select a style number - a sample portion of a PLC module appears.

There are about two dozen symbols (with a file name "HP?\*.dwg" where "?" is the style number) associated with each style in the library folder. To create a style, copy an existing style's symbols to one of the unused style numbers (6-9) and edit each library symbol.

Library folder:

**Windows XP:** C:\Documents and Settings\All Users\Documents\Autodesk\Acade {version}\Libs\{library}\

**Windows Vista, Windows 7:** C:\Users\Public\Documents\Autodesk\Acade {version}\Libs\{library}\

- 3 Specify the module box dimensions for the selected style.

These values set the right, left, top, and bottom offsets for the rectangle that surrounds the module. The optional Split Top and Split Bottom specify the offsets for a split module where Split Top specifies the offset for the top of a split module and Split Bottom specifies the offset for the bottom of the split module. If left blank, the rectangle Top and Bottom values are used.

- 4 Specify any properties for the lines that make up the box. You can set the color and linetype using the properties fields. To predefine the color, enter "COLOR colorname" into the box. For linetype, enter "LTYPE linetypename" in the box.
- 5 Click OK.

### Modifying the terminal block settings

The Terminal Block Settings dialog box is used to manage the library symbols in the PLC Database File Editor. You can add a terminal to the list by clicking in any box in the last entry of the list. A blank entry line is added to the bottom of the list. You must define the block name, assign it to a terminal category for selection, give it a description, and assign a bitmap to be used for dialog box appears.

The list shows the block name, category, unique description, and sample bitmap file for each terminal type.

<b>Block Name</b>	As defined when creating the parametric PLC blocks. Block file names adhere to the naming conventions to identify the PLC style numbering in the third position and the orientation in the first position.
-------------------	--

<b>Category</b>	Used in the PLC Database File editor to easily find specific types of terminals.
<b>Unique Description</b>	These descriptions are used during the terminal type selection process. They need to be maintained as unique
<b>Sample Bitmap File</b>	<p>This file is also used by the PLC database File editor to display a view of the terminal for selection.</p> <p>Symbols and BMP files need to be created outside of the PLC database file editor. Symbols are found in the standard library search path, while PLC Bitmap images are maintained in the same OS folder as the PLC Database itself</p> <p><b>Windows XP:</b> C:\Documents and Settings\{username}\My Documents\Acade {version}\AeData\  <b>Windows Vista, Windows 7:</b> C:\Users\{username}\Documents\Acade {version}\AeData\  </p>

- 1 In the PLC Database File Editor dialog box, click Settings.  
The Terminal Block Settings dialog box lists the library symbols for the terminal blocks that appeared in the Select Terminal Information dialog box. Notice that row 1 lists the block file name and sample bitmap file for the terminal we selected for Terminal Type 1.
- 2 Switch between the various graphic styles. Notice that the block name updates depending on the style and orientation you select. For example, the block name is "HP1WA-DL" for Style 1, Horizontal. If you select Style 4, Vertical the block name changes to "VP4WA-DL".  
Graphical styles are used during the operation of the PLC Parametric Selection process. These bitmap images appear during normal operation and selection of PLC entries and are found at C:\Program Files\Autodesk\Acade {version}\Acade. Use the same file names that are already there: P\_STYLEx.bmp where 'x' is the plc style 1-9.
- 3 Click View DWG or View Bitmap to view the PLC parametric symbols.
- 4 After you are done viewing the various symbols, click Cancel.

### **Adding terminal attributes**

- 1 Select the first terminal in the list of terminals.  
The attributes associated to the block, along with any predefined values, appear below the Tree Structure section of the dialog box.

LINE1	LINE2	LOC	MFG	TAG	TERM_
RACK %%1	SLOT %%2		Allen-Bradley	R%%1.S%%	1

Notice that the value for the LINE1 is RACK %%1 and LINE2 is SLOT %%2. The prompting values of %%1 and %%2 are populated with what you type into the text box when prompted. The static text of Rack and Slot appears in the attribute once the PLC module is created. There are multiple prompting variables from %%1 through %%9. Prompting strings can be added to any existing attributes on the terminal block. If you wanted to add additional prompts with out using the existing attributes you would have to modify the block file to add additional attributes such as Line3.

Top terminals are the only symbols which can accept prompts during the parametric PLC insertion process.

**2** Edit each attribute value for the TAG attributes to read "IN-%%N."

Besides the Module Prompt variables, AutoCAD Electrical also supports the use of an address variable. When the module is inserted, the PLC I/O addresses are calculated based on some AutoCAD Electrical settings and the module settings. You can trigger AutoCAD Electrical to include a prefix or suffix to each address value it inserts.

The %%N represents the calculated I/O address and the IN- is the prefix that gets added to the address value. You can also use the prompt values. For example, if you want to permanently encode the rack and group numbers (%%1 and %%2 prompts) into each I/O address value, encode each I/O address entry in the data file with "TAGA\_=%%1%%2%%N."

**3** If you want to assign a text constant to any attribute value, combine a text constant with the variables as shown in the module prompts and addressing examples above.

**Inserting the PLC module into the drawing**

**1** Click Save Module to save the module to the PLC database file.

**2** Click Done/Insert.

The PLC Parametric Selection dialog box appears.

**3** Click OK to insert the new PLC module onto the drawing.

**4** Specify the insertion point on the drawing.

**5** In the Module Layout dialog box, click OK.

- 6 In the I/O Address dialog box, specify a beginning I/O address or use the quick picks to select an address (such as I:/00).
- 7 Click OK.

Your module should look like the following. The Manufacturer, Catalog Number, and Description attributes also display at the top of the module (not shown).

R/S	
1	<input type="text" value="I:/00"/>
2	<input type="text" value="I:/01"/>
3	<input type="text" value="I:/02"/>
4	<input type="text" value="I:/03"/>
5	<input type="text" value="I:/04"/>
6	<input type="text" value="I:/05"/>
7	<input type="text" value="I:/06"/>
8	<input type="text" value="I:/07"/>
9	<input type="text"/>



# Customize Circuit Builder

## Circuit Builder overview

The Circuit Builder tool comes prepopulated with data to build and annotate a sampling of motor control circuits and power feed circuits. Circuits include 3-phase, single-phase, and one-line circuit representations. Each circuit is built dynamically, adjusting the power bus to match the wire bus for the drawing, adding wiring between components, and annotating the elements with suggested values based upon the selected load. Each time a circuit is configured, it is added to a history list of circuits. This list provides for quick reinsertion at a later time.

Three items control this feature:

- The [spreadsheet](#) on page 2006 defines the available circuits, circuit types, and defaults for each option within a circuit.
- The [template](#) on page 2010 (.dwg file) for a selected circuit defines the placement for the individual components and the wiring.
- The [electrical standards database](#) on page 2015 provides the values used to annotate the circuit, size circuit components, and provide the appropriate motor wire type.

### Workflow

- 1 Circuit Builder opens the spreadsheet and reads in the first sheet named "ACE\_CIRCS".
- 2 Circuit Builder shows the list of defined circuits in the Circuit Selection dialog box.
- 3 Select a circuit to insert or configure. The associated line from the ACE\_CIRCS sheet provides the base drawing template name, and the name of a circuit code sheet. The circuit code sheet is a separate sheet within the Circuit Builder spreadsheet.
- 4 The base drawing template for the circuit inserts at your selected location.
- 5 Circuit Builder finds and reads the attributes on all the special marker blocks on the inserted drawing template.
- 6 Circuit Builder matches each marker block to a specific section in the circuit codes sheet. This section can be a single spreadsheet row or

multiple consecutive rows in the circuit codes sheet. The section identifies one of the following:

- The action taken at this marker block location in the circuit. For example, calculate a wire type, insert a wire number, or adjust rung spacing.
- Provides a list of component insertion options that can be inserted at this point in the circuit. For example, presents a selection list containing a fuse, circuit breaker, or disconnect switch symbol.

Each marker block is processed in sequence, controlled by an ORDER attribute value carried on each marker block

- 7 A marker block can insert a nested template into the main circuit template. If the nested template carries its own marker blocks, these marker blocks are added to the overall list to process. When all marker blocks have been processed, the circuit is complete.

## Circuit Builder spreadsheet

The Circuit Builder spreadsheet, `ace_circuit_builder.xls`, along with the template drawings that it references, control what is displayed in the Circuit Selection and Circuit Configuration dialog box options. The first sheet in the spreadsheet, `ACE_CIRCS`, contains the main circuit categories, for example “3ph Motor Circuit”, and types, for example “Horizontal - FVNR - non reversing”. Along with this first sheet, are one or more circuit code sheets. These sheets contain the information necessary to insert or configure a specific circuit selected from the first sheet.

The `ace_circuit_builder.xls` circuit builder spreadsheet can be relocated into any of the normal AutoCAD Electrical or AutoCAD support paths.

The default location for the spreadsheet is:

- **Windows XP:** `C:\Documents and Settings\All Users\Documents\Autodesk\AcadE {version}\Support\`
- **Windows Vista, Windows 7:** `C:\Users\Public\Documents\Autodesk\AcadE {version}\Support\`

The default spreadsheet name, “`ace_circuit_builder.xls`”, can be overridden by setting the environment variable, `WD_CIRCBUILDER_FNAM`, in the `wd.env` on page 1984 file.

### ACE\_CIRCS sheet

Circuit Builder reads the list of circuit categories and types from the first sheet in the spreadsheet, ACE\_CIRCS. This information appears in a tree-structure selection window in the Circuit Selection dialog box. The ACE\_CIRCS sheet contains the following columns.

<b>CATEGORY</b>	A major circuit category displayed at the highest level of the tree structure in the Circuit Selection dialog box.
<b>TYPE</b>	The specific type of circuit within a major category. The circuit types appear at the second level of the tree structure.
<b>DWG_TEMPLATE</b>	The drawing template that is inserted when this circuit is selected. If a .dwg extension is not present, it is assumed.
<b>SHEET_NAME</b>	The circuit code sheet name that is referenced for the selected circuit template. This circuit code sheet carries the definitions for all the marker blocks in the selected drawing template and any nested templates.
<b>ANNO_CODE</b>	Code maps to the ANNO_CODE table in the spreadsheet. Allows you to predefine the description, installation, location, and other key information, for the motor or load and the individual components that might be inserted into the circuit.

### Circuit code sheets

Once a circuit is selected from the Circuit Selection dialog box (the CATEGORY and TYPE fields from the ACE\_CIRC sheet), the associated drawing template is inserted (the DWG\_TEMPLATE field), and a related circuit code sheet is ready for reference (the SHEET\_NAME field).

The inserted [drawing template](#) on page 2010 contains special marker blocks. Each marker block contains a CODE attribute with a value. This CODE value is used to match up with a section in the circuit code sheet. The matching section in the circuit code sheet provides the key information on what action is required at this physical location in the circuit.

Each circuit code sheet contains the following columns.

<b>CODE</b>	Value is matched to the CODE attribute value on the marker block. Each code corresponds to one circuit element in the list or an action/decision that takes place at the insertion point of the marker block.
-------------	---

<b>COMMENTS</b>	Text displayed in the Circuit Elements list in the Circuit Configuration dialog box.
<b>UI_DEF</b>	The default option for a circuit element is marked with an "X". When a circuit is inserted rather than configured, all elements marked with "X" are used to build the selected circuit.
<b>UI_TITLE</b>	<p>Title for the group of options in the middle Select section of the Circuit Configuration dialog box. Each circuit element can have one or more groups of options. For example, the main disconnecting means might have two groups of options, the disconnecting means itself and an optional auxiliary contact.</p> <p>This field can also contain a predefined code to bring up a separate dialog instead of driving the middle Select section of the main Circuit Configuration dialog box. There are two pre-defined codes:</p> <p><b>!MCC_CTRL</b> - invokes the <a href="#">Select Motor</a> on page 710 dialog box when the Browse button on the Motor Setup section of the <a href="#">Circuit Configuration</a> on page 708 dialog box is selected. It must be combined with the ace_cb_motor_select API call in the LOOKUP_CMD entry.</p> <p><b>!PF_CTRL</b> - invokes the <a href="#">Select Load</a> on page 711 dialog box when the Browse button on the Load Setup section of the <a href="#">Circuit Configuration</a> on page 708 dialog box is selected. It must be combined with the ace_cb_power_feed_select API call in the LOOKUP_CMD entry.</p> <hr/> <p><b>NOTE</b> Include the ace_cb_wire_select API call in the LOOKUP_CMD entry to invoke the <a href="#">Wire Size Lookup</a> on page 712 dialog box when the Browse button in the Wire Setup section of the Circuit Configuration dialog box is selected.</p> <hr/>
<b>UI_PROMPT_LIST</b>	The text to display in the middle Select section for each option within this group.
<b>UI_VAL</b>	<p>A numerical value assigned to the selection from each group. These numerical values are added up and matched to the value in the UI_SEL column.</p> <hr/> <p><b>NOTE</b> This value must be inserted as a text value in the spreadsheet and not as a number. An apostrophe character in front of the number forces the spreadsheet software to interpret it as a text value. You can also format the cells specifically as text. The text appears left justified in the cell.</p> <hr/>

<b>UI_SEL</b>	<p>A numerical value matched to the sum total of the values in the UI_VAL column for each selection made within a group. The COMMAND_LIST value from this row is used to insert the selected options.</p> <hr/> <p><b>NOTE</b> This value must be inserted as a text value in the spreadsheet and not as a number. An apostrophe character in front of the number forces the spreadsheet software to interpret it as a text value. You can also format the cells specifically as text. The text appears left justified in the cell.</p> <hr/>
<b>COMMAND_LIST</b>	<p>The command calls to insert the selected options.</p> <hr/> <p><b>NOTE</b> These calls are generally set up using standard AutoLISP format. Multiple calls can be concatenated in the same cell or in subsequent rows of the sheet. If multiple rows are used, the UI_SEL value cell is repeated. Anything after a semi-colon character is interpreted as a comment</p> <hr/>
<b>ANNOTATE_LIST</b>	<p>Optional command calls to annotate the circuit element. The ANNOTATE_LIST calls execute after all rows of the COMMAND_LIST calls have executed.</p>
<b>LOOKUP_CMD</b>	<p>Optional command calls to perform the electrical standards database or catalog lookups for the selected circuit element. This field controls the right-hand side of the Circuit Configuration dialog.</p>
<b>TABLEn</b>	<p>Optional catalog lookup table name. If the option contains multiple components, such as a disconnect switch and a fuse, there are multiple columns where "n" increments for each component.</p>
<b>TITLEn</b>	<p>The title for the component within the Setup &amp; Annotation section on the Configuration dialog box. If the option contains multiple components, such as a disconnect switch and a fuse, there are multiple columns where "n" increments for each component.</p>

### **ANNO\_CODE sheet**

Allows you to predefine the description, installation, location, and other key information for the motor or load and the individual components inserted into the circuit.

<b>ANNO_CODE</b>	Value is matched to the ANNO_CODE value from the ACE_CIRCS sheet.
<b>CODE</b>	Value is matched to the CODE value of the marker block on the circuit template.

<b>ATTRIBUTE</b>	Attribute name on the component inserted at the position of the marker block.
<b>PROMPT</b>	Text prompt displayed in the Annotation Presets dialog box.
<b>DEFAULT</b>	The default value for the attribute if annotation presets are <a href="#">listed</a> on page 708 or <a href="#">applied</a> on page 706. This value can be a text value or an AutoLISP expression that returns a text value.
<b>OPTIONS</b>	Future

## How Annotation Presets work

- 1 Make a selection from the Circuit Selection dialog box, for example "Horizontal - FVNR - non reversing". This selection has a value in the ANNO\_CODE cell, "ANNO\_3M".
- 2 Circuit Builder finds the group of entries that match up with code "ANNO\_3M" in the ANNO\_CODE sheet of ace\_circuit\_builder.xls.
- 3 If any matching entries are found, the Special Annotation: Presets section of the Circuit Selection dialog box, is enabled.
- 4 If you select Presets and click the Presets List button, the Annotation Presets dialog box displays. The rows displaying the entries with non-blank DEFAULT values are initially marked as Selected.
- 5 Edit the attribute values as necessary and click OK.
- 6 Select to Insert or Configure the circuit.
- 7 Circuit Builder processes each marker block on the circuit template. If the CODE value matches the CODE value from the ANNO\_CODE rows, the attribute values marked as Selected in the Annotation Presets dialog box are applied to the target attributes of the inserted component. If a target attribute is not found, the value is inserted as an Xdata value.

## Circuit Builder drawing templates

Each circuit starts with a main drawing template. These main circuit template drawings are named "ace\_cb1\*.dwg". Branching or nested circuit drawing templates are named "ace\_cb2\*.dwg". A branching circuit is a circuit inserted as an option on to the main circuit, for example a control transformer circuit or a power factor correction circuit.

The circuit drawing templates use the following naming convention.

- ace\_cb1\_\*.dwg - primary circuit drawing templates
- ace\_cb2\_\*.dwg - branching or nested circuit drawing templates

The default location for the circuit drawing templates is the schematic library folder:

- **Windows XP:** C:\Documents and Settings\All Users\Documents\Autodesk\AcadE {version}\Libs\{library}\
- **Windows Vista, Windows 7:** C:\Users\Public\Documents\Autodesk\AcadE {version}\Libs\{library}\

One-line template drawings have a "1-" suffix. The default location is in a "1-" folder under the schematic library folder.

- **Windows XP:** C:\Documents and Settings\All Users\Documents\Autodesk\AcadE {version}\Libs\{library}\1-
- **Windows Vista, Windows 7:** C:\Users\Public\Documents\Autodesk\AcadE {version}\Libs\{library}\1-

---

**NOTE** This template drawing naming convention is recommended but is not required for Circuit Builder to function.

---

A circuit template contains the wiring framework for the circuit and special marker blocks. These marker blocks are nothing more than instances of a standard AutoCAD block, ace\_cb\_marker\_block, carrying three attributes. These marker blocks tell Circuit Builder that some action or decision is required at the insertion point of the marker block. The action can be:

- Insert a component.
- Insert a multi-pole component.
- Make a wire type assignment to the underlying wire.
- Insert a wire number on the underlying wire.
- Decide if a branching circuit is needed.
- Decide if an underlying wire stretches and connects to a nearby power bus.
- Decide if underlying wire bus spacing adjusts.

- Decide if an underlying wire is trimmed.
- Set up the circuit annotation.

---

**NOTE** If you choose to Insert a circuit, bypassing the Circuit Configuration dialog box, the default options, as defined in the [Spreadsheet](#) on page 655, for each circuit element are used.

---

### Marker block attributes

<b>CODE</b>	This attribute value provides the link between the marker block on the circuit template drawing and a section in the circuit codes sheet. The value on this attribute matches with the CODE column value in the circuit codes sheet for the selected template.
<b>ORDER</b>	This attribute value controls the sequence of circuit element display and insertion within the circuit. Marker blocks are processed in order, from low to high. Assigning the same order value to multiple marker blocks links multiple marker blocks together for processing as a group. For example, to adjust the spacing between multiple wires of a 3-phase bus there are three marker blocks with a common CODE value and a common ORDER value. The ORDER value can be an integer or a decimal number value. Support for decimal number order values makes it easy to add a marker block between two others without having to reorder everything.
<b>MISC1</b>	<p>This attribute value contains miscellaneous annotation values, actions, and flags. Annotation values are in the format &lt;attribute name&gt;=&lt;attribute value&gt;. Actions can include embedded AutoLISP expressions or programs. Flags are key words that include enabling child contacts to link to parents and overriding multi-pole build directions. Flag codes include the following</p> <ul style="list-style-type: none"> <li>■ <b>_TAGFMT=&lt;value&gt;</b> - override the drawing property component tag format or wire number format setting for this one instance.</li> <li>■ <b>_PRETAG=&lt;value&gt;</b> - predefine a default alias tag for parent child linking. This option can be used for situations when the child component is inserted before the parent. For example, the marker block for the child contact has "_PRETAG=MR". When the parent coil is inserted, its marker block also has "_PRETAG=MR". As the circuit completes, the actual tag value of the parent annotates on to the child contact. This action is based upon the matching "MR" alias assigned to each.</li> <li>■ <b>_WIRENO=&lt;value&gt;</b> - predefine a fixed wire number.</li> <li>■ <b>WIRENUMBERS=0</b> - if a required wire type does not exist, create it and mark it as No Wire Numbering. If a required wire type does not exist and this flag is missing or has a value of 1, create it and mark it as Wire Numbering.</li> <li>■ <b>_WIRETYPE=&lt;value&gt;</b> - predefine the wire type layer name.</li> </ul>



- **\_WIRESKIP=<value>** - number of wires to skip over when trying to connect to another wire.
- **\_MAXTRAPCOUNT=<value>** - maximum search distance to look for a wire connection, given in wire connection trap units. The wire connection trap value is fixed and is displayed on the [Drawing properties: drawing format tab](#) on page 231 for the active drawing.
- **\_BASE** - indicates a base wire, the one that does not move, when setting up to adjust multiple bus wire spacing. If not defined, the wire that is co-linear with the insertion point of the template becomes the default base wire.
- **\_L =<value>**- each sublist, delimited by "|" characters, can predefine attribute values for individual poles of a multi-pole component, set of terminals, or set of cable markers.
- **\_D=<value>** - define the build direction override for a multi-pole component. 1=build right, 2=build up, 4=build left, 8=build down. Without an override, the build direction is down for horizontal inserts, and from left to right for vertical inserts.
- **X=<value or AutoLISP expression>** - reposition the marker block in the "X" direction. For example, "\_X>(\* 0.5 DIST01)" means adjust the position of this marker block in the X direction by an amount equal to 0.5 times the bus spacing distance defined by marker block with a CODE attribute value of "DIST01". This example can be used to position a marker block for a single phase motor insertion point, halfway between two power bus wires.
- **\_Y=<value or AutoLISP expression>** - reposition the marker block in the "Y" direction.

---

**NOTE** The flags defined in the circuit drawing marker blocks override any spreadsheet settings.

---

### Marker block functions

All marker blocks have the same block name, `ace_cb_marker_block`, but can have a wide variety of functions. The specific function assigned to a marker is based on its CODE attribute value and what this code value maps back to in the circuit code sheet for the circuit template. Here are the categories of marker block functions:

<b>Setup</b>	Blocks that define the circuit properties, such as motor selection.
<b>Wire Type</b>	Blocks that define the wire type layers layer to assign to the wire network under the block.

<b>Wire Number</b>	Blocks that define a wire number to assign to the wire under the block.
<b>Nested Circuit</b>	Blocks that define the placement of a branching or nested circuit such as a control circuit at the insertion point of the marker block.
<b>Component</b>	Blocks that define the placement of a component, connector, terminal, cable marker, or a multi-pole component at the insertion point of the marker block.
<b>Bus Spacing</b>	Blocks that control rung spacing adjustment for the wires under these blocks. Blocks that are processed as a group must carry common CODE and ORDER attribute values.
<b>Wire Connections</b>	Blocks that control stretching a wire segment to connect to another wire.

---

**NOTE** The name of the marker block cannot be changed. The Circuit Builder command only processes marker blocks named "ace\_cb\_marker\_block".

---

### One-line circuit templates

One-line circuit templates use the same marker block concept as three-phase motor and power feed circuit templates. However, there are a few differences. There is a single line wire that represents a multi-wire bus. Most of the one-line circuit templates contain a special "bus-tap" symbol.

The bus-tap symbol can have two functions:

- Provide an anchor point for the one-line circuit representation that begins at this location.
- Break into the one-line bus where the circuit connects.

On a dual circuit one-line template, there are three of bus-tap symbols. One at the normal point where the circuit ties into the bus. There is another version of the symbol on each of the two circuit "legs", each marking the point where that part of the dual circuit starts. These bus-tap symbols allow various reports to report accurately on a one-line circuit, whether a single circuit or a dual circuit representation.

The following bus-tap symbols are supplied:

- HDV1\_BT\_1-.dwg - with "dot" for horizontal one-line circuit
- VDV1\_BT\_1-.dwg - with "dot" for vertical one-line circuit
- HDV1\_BTT\_1-.dwg - "tee" connection for dual horizontal circuit

- VDV1\_BTT\_1-.dwg - “tee” connection for dual vertical circuit
- HDV1\_BTL\_1-.dwg - “corner” connection for dual horizontal circuit
- VDV1\_BTL\_1-.dwg - “corner” connection for dual vertical circuit

---

**NOTE** A WDTYPE attribute with a “1-1” value, identifies a bus-tap symbol.

---

## Circuit Builder database

Circuit Builder uses an electrical standards database to define default values, define engineering calculations, annotate circuits, and provide wire size recommendations. The electrical standards database, ace\_electrical\_standards.mdb, is located in the catalog folder. The default location is:

- **Windows XP:** C:\Documents and Settings\{username}\My Documents\Acade {version}\AeData\Catalogs\
- **Windows Vista, Windows 7:** C:\Users\{username}\Documents\Acade {version}\AeData\Catalogs\

Sizing and wire type values are based on information from the electrical standards database. Circuit Builder looks for a match on the motor size, supply voltage, and phase. On a match, Circuit Builder provides the Full Load Amp value, recommended motor power conductor size, and suggested rating values for various branch circuit protection elements such as circuit breakers, fuses, and disconnect switches.

The electrical standards database also allows Circuit Builder to provide engineering estimates and “green” calculations in the area of power conductor size versus energy losses. Designing to meet minimum code requirements can conflict with green design. For example, designing to the minimum conductor size for a given load can provide short-term savings on material cost but run up longer-term expense due to higher heating losses in the wiring. Over the life of the installation, the energy lost in heating up the minimum-sized wiring, instead of reaching the load to do useful work, could be substantial.

During wiring sizing, Circuit Builder displays not only a list of the valid wire sizes meeting the ampacity requirements of the load, but also a list of the estimated maximum energy loss cost for each wire size. This set of calculations allows you to make better green design decisions. For example, you decide to oversize the conductors for a motor to reduce conductor heating losses. This results in a higher initial cost for material and installation labor. However,

this cost is recovered many times over in reduced energy losses in the wiring during the life of the installation.

---

**NOTE** The ace\_electrical\_standards.mdb file replaces the mcc.mdb file used in previous versions of Circuit Builder.

---

The electrical standards database contains multiple tables used by Circuit Builder.

<b>MOTOR</b>	Contains the values used to populate the <a href="#">Select Motor</a> on page 710 dialog box.
<b>FEED</b>	Contains the values used to populate the <a href="#">Select Load</a> on page 711 dialog box. This table name can have an optional suffix to relate it to a specific electrical standards code.
<b>OPT</b>	Options tables contain values defining defaults and options lists specific to an electrical standard. For example, default to copper wiring, AWG size standard, and feet for conductor length units.
<b>AMP_{wire type}_{wire size standard}</b>	Wire ampacity tables contain the ampacity ratings for different conductor sizes and insulation temperature ratings.
<b>AMPG_{wire type}_{wire size standard}</b>	Grounding conductor sizing tables contain the maximum ampacity ratings for different grounding conductor sizes. This information is used to retrieve the minimum grounding conductor size and provide a selection list of larger sizes.
<b>INSUL_{wire type}_{wire size standard}</b>	Wire insulation tables lists the insulation types, the maximum temperature rating for each, and de-rating factors for each based on a series of temperatures.
<b>XL&amp;R_{wire type}_{wire size standard}</b>	Conductor Reactance/AC Resistance tables contain values used to estimate single-phase and three-phase voltage drop values.
<b>XL&amp;R_DESC</b>	Conduit/raceway descriptions list used with the XL&R_{wire type}_{wire size standard} tables.
<b>FILL</b>	Fill tables contain the ampacity de-rating factors used when there is more than one current carrying conductor (power wiring, not ground, neutral, or control wires) in the same conduit, duct, or raceway.

<b>MOTOR_I_DESC</b>	Lists the component type descriptions whose sizing ties directly into the full load amps value (FLA) of the motor or load. The CODE value maps to the MOTOR_I_CALC and MOTOR_I_MAP tables.
<b>MOTOR_I_CALC</b>	Lists the formula to calculate the maximum amp value for various types of components on a per motor type basis.
<b>MOTOR_I_MAP</b>	Maps the calculated FLA for a component to a specific rating value and an optional catalog assignment.

---

**NOTE** Each table name can have an optional suffix to relate it to a specific electrical standards code.

---

### Motor table

The data in the Motor table is used to populate the [Select Motor](#) on page 710 dialog box. Filter the selection list by type, voltage, and frequency. The load and FLA values for the selected motor are passed back to the Circuit Configuration dialog box and are used in wire size calculations. The values are also used to calculate breaker size, fuse size, and disconnect switch rating, for the selected motor.

The MOTOR table follows this table naming convention:

- MOTOR - if no specific electrical standards table is found, the default table name to use.
- `_{standard}` - optional suffix to relate it to a specific electrical standards code. For example, an “\_NEC” suffix could mean that the data for the table parallels the National Electrical Code. A suffixed MOTOR table name is not necessary unless you plan to set up the electrical standards database to support multiple standards.

### Feed table

The data in the Feed table is used to populate the [Select Load](#) on page 711 dialog box. Filter the selection list by type, voltage, and frequency. The load and FLA values for the selected feed are passed back to the Circuit Configuration dialog box and are used in wire size calculations. The values are also used to calculate breaker size, fuse size, and disconnect switch rating, for the selected load.

The FEED table follows this table naming convention:

- FEED - if no specific electrical standards table is found, the default table name to use.
- `_{standard}` - optional suffix to relate it to a specific electrical standards code. For example, an “\_NEC” suffix could mean that the data for the table parallels the National Electrical Code. A suffixed FEED table name is not necessary unless you plan to set up the electrical standards database to support multiple standards.

### Options tables

Options tables contain values defining defaults and options lists specific to an electrical standard. For example, default to copper wiring, AWG size standard, and feet for conductor length units.

The OPT table follows this table naming convention:

- OPT - if no specific electrical standards table is found, the default table name to use.
- `_{standard}` - optional suffix to relate it to a specific electrical standards code. For example, an “\_NEC” suffix could mean that the data for the table parallels the National Electrical Code. A suffixed OPT table name is not necessary unless you plan to set up the electrical standards database to support multiple standards.

Name	Description
FLA_MULT	<p>Default full load amps multiplier value used to determine a maximum load. For example, the full load amps for a motor is rated at 10 amps and the FLA_MULT default is set to 1.25. The minimum wire size calculation for the wiring for the motor is based upon an ampacity rating of not 10 amps but 12.5 amps (10 amps x 1.25).</p> <p>The FLA_MULT factor displays in the <a href="#">Select Motor</a> on page 710 and <a href="#">Wire Size Lookup</a> on page 712 dialog boxes.</p>
C_LOAD	<p>Continuous load correction factor for wire size ampacity de-rating. If the electrical load is anticipated to be a continuous load, a default de-rating factor can be automatically applied to the wire size ampacity calculation.</p> <p>For example, a given electrical code defines the Continuous load correction factor at a value of 0.8. This means that a given wire size that normally has a maximum rated ampacity value of 20 amps is de-rated to a maximum ampacity of 16 amps when the wiring is to power a motor that is expected to be a con-</p>

Name	Description
	tinuous load. The wire size calculation may need to select the next larger wire size.
W_METAL	Default wire metal value used to determine appropriate wire ampacity and wire insulation table names. For example, "CU" to define copper wiring as the default, "AL" to define aluminum wiring as the default.
W_STD	Default wire type standard used to determine appropriate wire ampacity and wire insulation table names. For example, "AWG" or "MM2".
V_DROP	Maximum allowable % voltage drop in power wiring. This value can be used to help calculate an appropriate wire size when the wire run distance is also defined.
W_INSUL	Default insulation type used to determine the ambient temperature correction factor.
LEN_LIST	Wire run distance values for pick list in the Wire Size Lookup dialog box. The run distance is used for estimated voltage drop calculations in the motor or load power wiring.
LEN_UNITS	Run distance units for power conductors and values for units pick list in the Wire Size Lookup dialog box. Run distance is used in the estimated voltage drop calculation. Units are either "FT" for feet or "M" for meters.
KWH_COST	Unit cost per kWh. This value is used for estimating a maximum annual cost of energy loss in the power wiring for a motor or load, assuming a continuous full load.
KWH_COST_UNITS	KWh cost units character used in the Wire Size Lookup dialog box showing the wire loss estimates. For example, "\$" for dollar, "€" for euro.
SHORTNAME	The code for the electrical standards name for this table. This <a href="#">code</a> on page 182 is saved in the project <i>.wdp</i> file when the standard is applied to a project.
FULLNAME	The full name of the electrical standards name for this table. This value, extracted from all the OPT tables, provides the values for the pick list when setting an Electrical Code Standard for a project from the <a href="#">Project properties: project settings tab</a> on page 204.
LEN_UNITS	Run distance units for power conductors and values for units pick list in the Wire Size Lookup dialog box. Run distance is used in the voltage drop calculation.

Name	Description
VOLTS	Default supply voltage value and values for voltage pick list in the Wire Size Lookup dialog box.
PHASE	Default supply phase value and values for phase pick list in the Wire Size Lookup dialog box. For example, "1" for single-phase, "3" for three-phase.
PARALLEL_MIN_SIZE	Default value for the minimum wire size when displaying paralleled wire option in the Wire Size Lookup dialog box. For example, "1-0 AWG".
PARALLEL_MAX_CNT	Default value for the maximum number of wire conductors when displaying paralleled wire option in the Wire Size Lookup dialog box. For example, "4" for up to four paralleled wires per phase.
T_AMBIENT	Default ambient temperature correction factor. This value is used in wire type sizing. It must match up with one of the temperature de-rating column labels found in the INSUL_* tables. For example, "30C".
M_POWERFACTOR	Default power factor for a motor. This value is used in estimated voltage drop calculations. For example, "0.85".
F_POWERFACTOR	Default power factor for a power feed. This value is used in estimated voltage drop calculations. For example, "0.85".
AMPG_MAX	Defines the expression to calculate the minimum grounding conductor ampacity size. The "I" in the expression represents the motor or load full load amps (FLA). The result of the expression is then applied to the appropriate AMPG table to determine the minimum grounding conductor size.



CODE	DEFAULT	LIST
FLA_MULT	1.25	
C_LOAD	0.8	
W_METAL	CU	
W_STD	AWG	
V_DROP	3	2,3,4,5
W_INSUL	THWN	
LEN_LIST		20,50,75,100,150,200,250
KWH_COST	0.08	
KWH_COST_UNITS	\$	€,€
SHORTNAME	Default (NEC)	
FULLNAME	Default (National Electrical Code)	
LEN_UNITS	FT	FT,M
VOLTS	480	120,208,240,480,575,600
PHASE	3	1,3
PARALLEL_MIN_SIZE	1-0	
PARALLEL_MAX_CNT	4	
T_AMBIENT	30C	
M_POWERFACTOR	0.85	0.80,0.85,0.90,1.0
F_POWERFACTOR	1.0	0.80,0.85,0.90,1.0
AMPG_MAX	(I* 1.75)	

**Wire Size Lookup**

Load: Voltage: 480 (13/14), Phase: 3 (15/16), FLA: 61.2, FLA multiplier: 1.25 (1), FLA (Other):, Maximum load: 76.5

Wire: Size standard: AWG (4), Type/method: CU (3), Insulation: THWN / 75C (7)

De-rating factors: Continuous load correction: 0.8 (2), Fill correction: 1.0, Ambient temperature correction: 26-30C (19), Total correction: 0.8

Parameters: Run distance: 20 (8), Units: FT (11/12), Via: Steel Conduit, Power factor: 0.85 (20-23), Maximum % voltage drop: 3 (5/6)

Paralleled wires: Include paralleled wire options: Maximum paralleled wire count: 4 (18), Minimum paralleled wire size: 1-0 (17), Cost per kwh: 0.08 (9)

\*Maximum 10 of wire losses for continuous use at rated load

Size	Count	Fill	Ampacity	%Ampacity	Voltage Drop	%Voltage Drop	Wire KW Loss	Wire Loss estimate(maximum annual cost)
10 AWG	1	1-3	30	255	2.21	0.46	0.23	\$ 161.29
8 AWG	1	1-3	50	153	1.48	0.31	0.16	\$ 112.20
6 AWG	1	1-3	65	117.69	0.96	0.2	0.1	\$ 70.13
4 AWG	1	1-3	85	90	0.63	0.13	0.07	\$ 49.09
3 AWG	1	1-3	100	76.5	0.52	0.11	0.06	\$ 42.08
2 AWG	1	1-3	115	66.52	0.43	0.09	0.05	\$ 35.06
1 AWG	1	1-3	130	58.85	0.35	0.07	0.04	\$ 28.05
1-0 AWG	1	1-3	150	51	0.28	0.06	0.03	\$ 21.04
1-0 AWG	1	4-6	120	63.75	0.28	0.06	0.03	\$ 21.04
1-0 AWG	1	7-9	105	72.86	0.28	0.06	0.03	\$ 21.04
2-0 AWG	1	1-3	175	43.71	0.24	0.05	0.03	\$ 21.04
2-0 AWG	1	4-6	140	54.64	0.24	0.05	0.03	\$ 21.04

6 AWG (24) Grounding conductor size

Description: Save as... OK Cancel Help

## Wire ampacity tables

The wire ampacity tables provide the wire conductor sizes, descriptions, and maximum FLA ampacity values based on wire size and standard insulation temperature ratings. This information is used in the following ways:

- Automatically select a default wire size based upon the maximum load amp value displayed in the [Select Motor](#) on page 710 or [Select Load](#) on page 711 dialog boxes.

- Automatically calculate or recalculate suggested wire sizes in the [Wire Size Lookup](#) on page 712 dialog box as various parameters and de-rating factors are applied.

The wire ampacity tables use the following naming convention:

- AMP - the table name prefix.
- `_{type}` - the wire metal type such as CU for copper, or AL for aluminum.
- `_{size}` - wire size standard such as AWG, or MM2 for metric.
- `_{standard}` - optional suffix to relate it to a specific electrical standards code. For example, an “\_NEC” suffix could mean that the data for the table parallels the National Electrical Code. A suffixed table name is not necessary unless you plan to set up the electrical standards database to support multiple standards.

For example, a table named AMP\_CU\_AWG\_NEC contains the wire ampacity information for copper, AWG sizes, and parallels what is found in the National Electrical Code.

Name	Description
SIZE	Wire size code. This value can be automatically pushed into a wire type layer name. For example, “12”, “250KCMIL”.
SIZE_DESC	Wire size description shown on the Wire Size Lookup dialog box. For example, “12 AWG”, “250 KCMIL”.
CIRC_MIL	Imperial cross-section value for the wire conductor size.
60C, 75C, 90C	Maximum ampacity rating values for the wire conductor size for each of these standard ambient temperature ratings. Additional columns can be added or an existing column can be deleted. For example, if local electrical codes do not support 90C, this field can be removed from the table and does not show up as an option in the Wire Size Lookup dialog box.

ID	SIZE	SIZE_DESC	CIRC_MIL	60C	75C	90C
1	18	18 AWG	1620			
2	16	16 AWG	2580			
3	14	14 AWG	4110			
4	12	12 AWG	6530	15	15	15
5	10	10 AWG	10380	25	25	25
6	8	8 AWG	16510	30	40	45
7	6	6 AWG	26240	40	50	60
8	4	4 AWG	41740	55	65	75
9	3	3 AWG	52620	65	75	85
10	2	2 AWG	66360	75	90	100
11	1	1 AWG	83690	85	100	115
12	1-0	1-0 AWG	105600	100	120	135
13	2-0	2-0 AWG	133100	115	135	150

**Wire Size Lookup**

Load: Voltage: 208, Phase: 3, FLA: 2.08, FLA multiplier: 1.25, FLA (Other): 3.25, Maximum load: 5.85

Wire: Size standard: AWG, Type/method: CU, Insulation: TBS/90C

Derating factors: Continuous load correction: 0.8, Fill correction: 7-9: 0.7, Ambient temperature correction: 61-70C: 0.58, Total correction: 0.406

Parameters: Run distance: 20, Units: FT, Via: Steel Conduit, Power factor: 0.85, Maximum % voltage drop: 3

Result: 1 x 2 = 3

Size	Ampacity	%Ampacity	Voltage Drop	%Voltage Drop	Wire KW Loss	Wire Loss estimate(maximum annual cost)
14 AWG	6.09	96.06	0.5	0.24	-	-
12 AWG	8.12	72.04	0.32	0.15	-	-
10 AWG	12.18	48.03	0.19	0.09	-	-
8 AWG	22.33	26.2	0.13	0.06	-	-
6 AWG	30.45	19.21	0.08	0.04	-	-
4 AWG	38.57	15.17	0.05	0.02	-	-
3 AWG	44.66	13.1	0.04	0.02	-	-
2 AWG	52.78	11.08	0.04	0.02	-	-
1 AWG	60.9	9.61	0.03	0.01	-	-
1-0 AWG	69.02	8.48	0.02	0.01	-	-
2-0 AWG	79.17	7.39	0.02	0.01	-	-
3-0 AWG	91.35	6.4	n.n	n.n	-	-

### Grounding conductor sizing tables

The grounding conductor sizing tables provide the grounding wire conductor sizes and maximum FLA ampacity values. This information is used in the following ways:

- Provide a suggested minimum grounding conductor size based on the amp value returned by the expression defined in the AMPG\_MAX entry in the OPT table.

- Provide a selection list on the [Wire Size Lookup](#) on page 712 dialog box giving this minimum suggested size plus all larger grounding conductor sizes.

The grounding conductor sizing tables use the following naming convention:

- AMPG - the table name prefix
- `_{type}` - the wire metal type such as CU for copper, or AL for aluminum.
- `_{size}` - wire size standard such as AWG, or MM2 for metric.
- `_{standard}` - optional suffix to relate it to a specific electrical standards code. For example, an “\_NEC” suffix could mean that the data for the table parallels the National Electrical Code. A suffixed table name is not necessary unless you plan to set up the electrical standards database to support multiple standards.

For example, a table named AMPG\_CU\_AWG\_NEC contains the grounding conductor sizing information for copper, AWG sizes, and parallels values found in the National Electrical Code.

Name	Description
SIZE	Wire size code. This value can be automatically pushed into a wire type layer name for the ground wire. For example, “12”, “250KCMIL”.
SIZE_DESC	Wire size description shown on the Wire Size Lookup dialog box. For example, “12 AWG”, “250 KCMIL”.
MAX	Maximum amp value associated to this grounding wire size. The value comes from the result of the expression held in the AMPG_MAX entry of the OPT table.

### Wire insulation tables

The wire insulation tables provide the option to de-rate wire conductor ampacity based upon expected maximum ambient temperature.

- Automatically select a default wire size based upon the maximum load amp value, displayed in the [Select Motor](#) on page 710 or [Select Load](#) on page 711 dialog boxes, and the default insulation type and ambient temperature rating defined in the W\_INSUL and T\_AMBIENT entries of the OPT table.

- Automatically calculate or recalculate suggested wire sizes in the [Wire Size Lookup](#) on page 712 dialog box as various insulation and temperature de-rating factors are applied.

The wire insulation tables use the following naming convention:

- `INSUL` - the table name prefix.
- `_{type}` - the wire metal type such as `CU` for copper, or `AL` for aluminum.
- `_{size}` - wire size standard such as `AWG`, or `MM2` for metric.
- `_{standard}` - optional suffix to relate it to a specific electrical standards code. For example, an “`_NEC`” suffix could mean that the data for the table parallels the National Electrical Code. A suffixed table name is not necessary unless you plan to set up the electrical standards database to support multiple standards.

For example, a table named `INSUL_CU_AWG_NEC` contains the wire insulation information for copper, AWG sizes, and parallels values found in the National Electrical Code.

<b>Name</b>	<b>Description</b>
<code>INSUL</code>	Insulation type code.
<code>INSUL_DESC</code>	Insulation type description shown on the Wire Size Lookup dialog box.
<code>TEMP</code>	Standard, maximum temperature rating for the insulation type.
<code>25C-80C</code>	A series of wire conductor ampacity de-rating factor values for maximum ambient temperature. Columns can be added or deleted. For example, if 30C is the minimum ambient temperature rating, the 25C column can be removed.

**INSUL\_CU\_AWG\_REC**

ID	INSUL	INSUL_DESC	TEMP	25C	30C	35C	40C	45C	50C	55C	60C	70C	80C
1	TW	TW	60C	1.08	1	0.91	0.82	0.7	0.58	0.41			
2	UF	UF	60C	1.08	1	0.91	0.82	0.7	0.58	0.41			
3	RHW	RHW	75C	1.05	1	0.94	0.88	0.8	0.75	0.67	0.58	0.33	
4	THHW	THHW (wet)	75C	1.05	1	0.94	0.88	0.8	0.75	0.67	0.58	0.33	
5	THW	THW	75C	1.05	1	0.94	0.88	0.8	0.75	0.67	0.58	0.33	
6	THWN	THWN	75C	1.05	1	0.94	0.88	0.8	0.75	0.67	0.58	0.33	
7	XHHW	XHHW (wet)	75C	1.05	1	0.94	0.88	0.8	0.75	0.67	0.58	0.33	
8	USE	USE	75C	1.05	1	0.94	0.88	0.8	0.75	0.67	0.58	0.33	
9	ZW	ZW	75C	1.05	1	0.94	0.88	0.8	0.75	0.67	0.58	0.33	
10	TBS	TBS	90C	1.04	1	0.96	0.91	0.8	0.82	0.76	0.71	0.58	0.41
11	SA	SA	90C	1.04	1	0.96	0.91	0.8	0.82	0.76	0.71	0.58	0.41
12	SIS	SIS	90C	1.04	1	0.96	0.91	0.8	0.82	0.76	0.71	0.58	0.41
13	FEP	FEP	90C	1.04	1	0.96	0.91	0.8	0.82	0.76	0.71	0.58	0.41
14	FEPB	FEPB	90C	1.04	1	0.96	0.91	0.8	0.82	0.76	0.71	0.58	0.41

**Wire Size Lookup**

Load: Voltage: 208, Phase: 3, FLA: 2.08, FLA multiplier: 1.25, FLA (Other): 3.25, Maximum load: 5.85

Wire: Size standard: AWG, Type/method: CU, Insulation: TBS / 90C

De-rating factors:
 

- Continuous load correction: 0.8
- Fill correction: 0.7
- Ambient temperature correction: 0.58

Parameters: Run distance: 20, Units: FT, Via: Steel Conduit, Power factor: 0.85, Maximum % voltage drop: 3

Paralleled wires: Include paralleled wire options: 4, Maximum paralleled wire count: 4, Minimum paralleled wire size: 1-0

Cost per kw/h: 0.08

\*Maximum cost of wire losses for continuous use at rated load

Size	Count	Fill	Ampacity	%Ampacity	Voltage Drop	%Voltage Drop	Wire KW Loss	Wire Loss estimate (maximum annual cost)*
14 AWG	1	1-3	15	39	0.5	0.24	-	-
12 AWG	1	1-3	20	29.25	0.32	0.15	-	-
10 AWG	1	1-3	30	19.5	0.19	0.09	-	-
8 AWG	1	1-3	55	10.64	0.13	0.06	-	-
6 AWG	1	1-3	75	7.8	0.08	0.04	-	-
4 AWG	1	1-3	95	6.16	0.05	0.02	-	-
3 AWG	1	1-3	110	5.32	0.04	0.02	-	-
2 AWG	1	1-3	130	4.5	0.04	0.02	-	-
1 AWG	1	1-3	150	3.9	0.03	0.01	-	-
1-0 AWG	1	7-9	119	4.92	0.02	0.01	-	-
1-0 AWG	1	10-20	85	6.88	0.02	0.01	-	-
1-0 AWG	1	21-30	76.5	7.65	0.02	0.01	-	-

## Conductor Reactance / AC Resistance tables

The optional conductor reactance/AC resistance tables provide the reactance and resistance values for wire size based on conduit type. These values are used to calculate the voltage drop percentage in power wiring when a run distance is supplied.

There are two types of tables for this feature. A conduit type description table and the reactance/resistance data tables.

### Conduit type description table

The description table, XL&R\_DESC, contains the labels used on the [Wire Size Lookup](#) on page 712 dialog box for the conduit or raceway type selection list. The labels also map to the columns in the data tables.

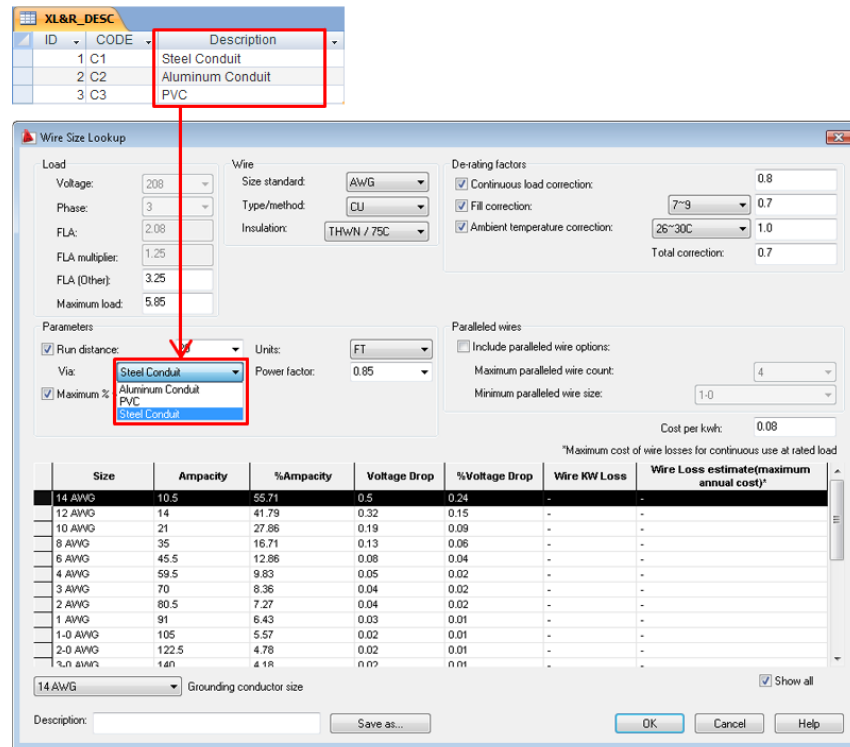

### Data tables

The conductor reactance/AC resistance data tables use the following naming convention:

- XL&R - the table name prefix
- `_{type}` - the wire metal type such as CU for copper, or AL for aluminum.
- `_{size}` - wire size standard such as AWG, or MM2 for metric.
- `_{standard}` - optional suffix to relate it to a specific electrical standards code. For example, an “\_NEC” suffix could mean that the data for the table parallels the National Electrical Code. A suffixed table name is not necessary unless you plan to set up the electrical standards database to support multiple standards.

For example, a table named XL&R\_CU\_AWG\_NEC contains the conductor reactance/AC resistance information for copper, AWG sizes, and parallels values found in the National Electrical Code.

Name	Description
SIZE	Wire size code.
C1-C3	A set of reactance and resistance values, semi-colon delimited for the conduit type. The first element is the estimated reactance and the second element is the AC resistance.

**NOTE** see the XL&R\_DESC table for the corresponding label for each. Data for additional conduit/raceway types can be added to this table with a corresponding entry added to the XL&R\_DESC table.

The screenshot shows two tables at the top and a 'Wire Size Lookup' dialog box below. The 'XL&R\_DESC' table has columns ID, CODE, and Description. The 'XL&R\_CU\_AWG\_NEC' table has columns ID, SIZE, C1, C2, and C3. The 'Wire Size Lookup' dialog has sections for Load, Wire, Derating factors, Parameters, and Paralleled wires. A table at the bottom of the dialog shows wire size data with columns: Size, Ampacity, %Ampacity, Voltage Drop, %Voltage Drop, Wire KW Loss, and Wire Loss estimate. Red boxes highlight 'Steel Conduit' in the 'Via' dropdown, 'C1' in the 'XL&R\_CU\_AWG\_NEC' table, and the '%Voltage Drop' column in the results table. A red arrow points from the '%Voltage Drop' column to the 'Used in calculation for Voltage Drop' text box.

**NOTE** See [Wire Size Lookup](#) on page 712 for the voltage drop calculation.



### **Fill tables**

When multiple current carrying wire conductors are in the same conduit, duct, or raceway, the wire ampacity may need to be de-rated. Current carrying wire conductors are defined as power wiring, not ground, neutral, or control wires. The Fill table provides the de-rating factor based on the maximum number of power wire conductors.

The FILL table follows this naming convention:

- FILL - the table name prefix.
- `_{standard}` - optional suffix to relate it to a specific electrical standards code. For example, an “\_NEC” suffix could mean that the data for the table parallels the National Electrical Code. A suffixed FILL table name is not necessary unless you plan to set up the electrical standards database to support multiple standards.

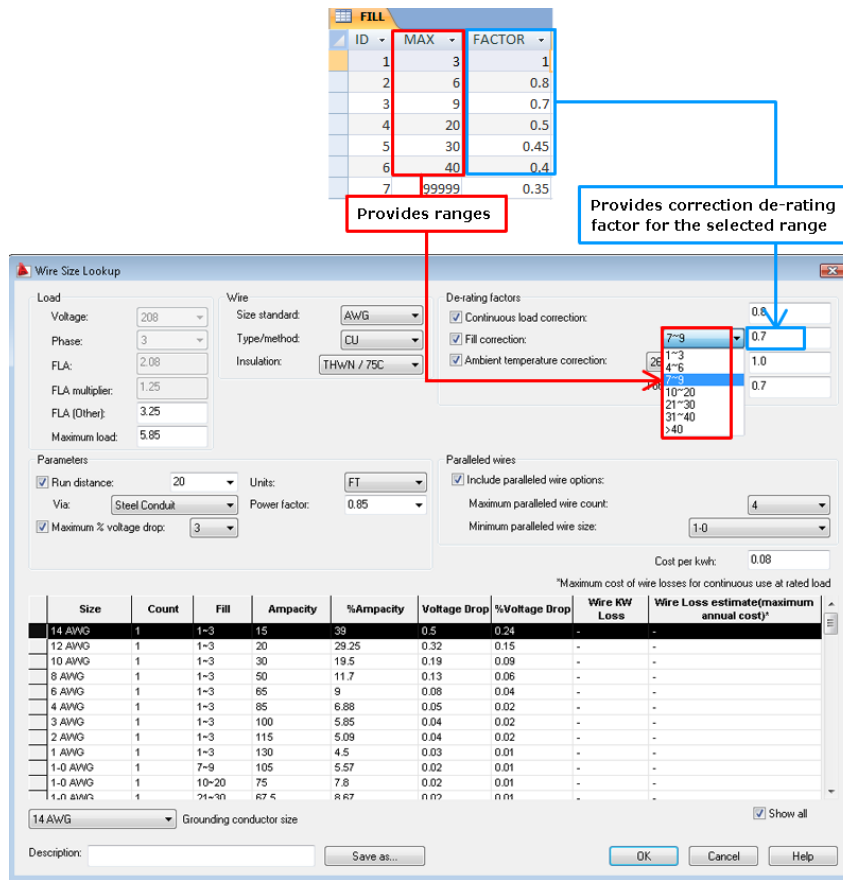

### MOTOR\_I\* tables

A set of three tables containing values used for calculating suggested breaker size, fuse size, and disconnect switch ratings for a given motor or load amp value. Each table name can have an optional suffix to relate it to a specific electrical standards code such as “\_NEC” for National Electrical Code.

### MOTOR\_I\_DESC

Lists the component type descriptions whose sizing ties directly into the full load amps value (FLA) of the motor or load. The CODE value maps to the MOTOR\_I\_CALC and MOTOR\_I\_MAP tables.

## MOTOR\_I\_CALC

Lists the formula to calculate the maximum amp value for various types of components on a per motor type basis. Each row gives a motor type followed by columns marked with the codes given in the MOTOR\_I\_DESC table. Each cell contains an expression to calculate a FLA value. The FLA value for the selected motor corresponds to the symbol "I" in the expression.

Valid operations are +,\*,/^. The “^” character is the exponential function. For example, I^2 is I squared, while I^0.5 is the square root of I.

If-then-else statements are supported including one level of nested statements. For example,

- (if (I > 400) then (I \* 8) else (I \* 11)) - the calculated amp value is eight times FLA current for 0-400 amps and 11 times for greater than FLA of 400 amps. One level of nesting is supported.
- (if (I >= 9.0) then (I \* 1.25) else if (I < 2.0) then (I \* 3.0) else (I \* 1.67)) - the calculated value is set to (I \* 1.67) if I is less than 9 but greater or equal to 2.0 amps. If I is less than 2.0 amps the calculated value is (I \* 3.0), and if greater than or equal to 9.0 amps, it is (I \* 1.25).

Valid Boolean operations are >, <, >=, <=, =.

## MOTOR\_I\_MAP

Maps the calculated FLA for a component to a specific rating value and an optional catalog assignment. The rating value is annotated to the symbol using the API call c:ace\_cb\_anno2 in the circuit builder spreadsheet.

The optional catalog assignment is defined in the Default field. Use the following format:

MFG={manufacturer};CAT={catalog};ASSYCODE={assembly code}

If the ASSYCODE value is not needed, use the format:

MFG={manufacturer};CAT={catalog}

## CATALOGSEL table

Circuit Builder uses the CATALOGSEL table to save the catalog selections made for the motor and other components. The catalog information is saved based on the motor size. If this same motor size is used later on another circuit, these previous catalog selections become the default values when they match up with the configured selections. For example, if the previous circuit was configured with a 10HP motor with time-delay fuses, and a 10HP motor with

time-delay fuses is selected for the new circuit, the previously used catalog selection appears as the default.

If the circuit is configured using the [Reference an existing circuit](#) on page 721 feature, the values are not used from the CATALOGSEL table but from the referenced circuit. However, if a new motor is then selected from the [Select Motor](#) on page 710 dialog box, the CATALOGSEL tables values are checked for a match.

## Add a new circuit

To add a new circuit to Circuit Builder there are three main tasks:

- Create the circuit drawing [template](#) on page 2032 (an AutoCAD .dwg file).
- Add a reference to this new circuit in the [ACE\\_CIRCS](#) on page 2038 sheet in the ace\_circuit\_builder.xls spreadsheet.
- Create or modify a [circuit codes](#) on page 2039sheet in the ace\_circuit\_builder.xls spreadsheet.

---

**NOTE** This exercise demonstrates the capabilities of Circuit Builder and the result may not necessarily be electrically valid.

---

### Create the circuit template

It is recommended that you read the [Circuit Builder drawing templates](#) on page 2010 topic before continuing.

A circuit template drawing is an AutoCAD .dwg file that contains the wiring framework for the circuit. On this wiring framework are positioned special marker blocks. These marker blocks are configured, using attribute values, to tell Circuit Builder that some action or decision is required at the insertion point of each marker block. One marker block might identify where to place the power disconnecting means for the circuit. Another marker block might identify that an underlying wire must be appropriately sized to the motor inserted at yet another marker block on the wire framework of the circuit template.

The easiest way to create a circuit template is to copy a similar template to a new name and modify the marker blocks on this copied template. For this example you copy the circuit template ace\_cb1\_FVNR\_H.dwg to a new name. It is the main template for a 3-phase, horizontal, full-voltage, non-reversing motor circuit. You modify this template to create a custom circuit template.

- 1 Locate the existing circuit template drawing file ace\_cb1\_FVNR\_H.dwg. Copies of the circuit builder templates are installed in each of the schematic library folders, JIC125, IEC2, and so onto. Copy this file to ace\_cb1\_FVNR\_H\_custom.dwg.

---

**NOTE** The circuit template name is not critical and does not affect functionality of Circuit Builder.

---

- 2 Open the copied and renamed circuit template, ace\_cb1\_FVNR\_H\_custom.dwg, in AutoCAD. Make sure that you have write access to the drawing.  
This template consists of three wires and some marker blocks.
- 3 Open ace\_circuit\_builder.xls in a spreadsheet software for reference. See [Circuit Builder spreadsheet overview](#) on page ? for the location of this file.

Use standard AutoCAD commands to modify the template and not AutoCAD Electrical commands. It avoids creating a template that contains an extra copy of the AutoCAD Electrical WD\_M block. If you accidentally use a command that inserts the invisible WD\_M block, either UNDO or erase and purge the WD\_M block instance. To erase and purge the invisible block, follow these steps:

- 1 Enter ATTDISP at the command prompt.
- 2 Enter ON to make all attributes visible.
- 3 Locate the block at 0,0.
- 4 Click Home tab ► Modify panel ► Erase.
- 5 Select the block and press enter.
- 6 Enter PURGE at the command prompt.
- 7 Select WD\_M in the Blocks section.
- 8 Click Purge.
- 9 Click Close.

### Define wires stretching to connect to bus

The first modification is to change the way the horizontal wires connect to the vertical bus when inserted. The copied template is defined as follows:

- Top wire skips over two wires and connects to the left-most vertical bus wire.
- Middle wire skips over one wire and connects to the middle vertical bus wire.
- Bottom wire connects to the first vertical bus wire it encounters.

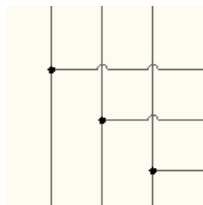

The following changes to the marker blocks reverse it.

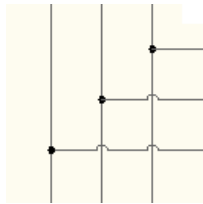

- 1 Zoom in on the left-hand side of the template.  
You should see three marker blocks, each with a CODE value of WCON. Each one is directly on top of and near the end of one of the wires.
- 2 Enter *ATTEDIT* and select the top WCON marker block.  
You should see the following values:
  - **CODE = WCON** - maps back to a row in the circuit codes sheet with a function to stretch the end of the underlying wire to try to make a connection.
  - **ORDER = 1.02** - indicates the order of processing for the marker block relative to all the other marker blocks in the template. The order value can be an integer number or a decimal number. The blocks are processed low to high starting at 0. Blocks with the same ORDER value are processed as a group.

- **MISC1 = \_WIRESKIP=2;\_MAXTRAPCOUNT=200** - defines any special handling of the marker block. See the [Marker block attributes](#) on page 660 topic for a complete list of supported values.

- 3 Change the MISC1 value to **\_MAXTRAPCOUNT=200**, removing **\_WIRESKIP=2**.

The **\_WIRESKIP** value defines the number of wires to skip over when trying to connect to the vertical bus when inserted. Removing this value directs Circuit Builder to connect to the first vertical wire it finds.

The **\_MAXTRAPCOUNT** limits the relative distance that circuit builder searches to find a wire to connect to. It is measured in an integer number of wire connection [trap](#) on page 232 distance units. If **\_MAXTRAPCOUNT** is not defined or is zero, the search is across the whole extents of the drawing.

- 4 Click OK.
- 5 Enter *ATTEDIT* and select the bottom WCON marker block.
- 6 Change the MISC1 value to **\_WIRESKIP=2;\_MAXTRAPCOUNT=200**, making sure to enter the semi-colon character between the values.

It tells Circuit Builder to skip over two vertical wires when trying to connect to the vertical bus and to search up to 200 times the trap distance for a vertical wire to connect to. If none are found within that distance, Circuit Builder will not stretch this wire.
- 7 Click OK.

### Remove unnecessary marker blocks

The copied circuit has marker blocks for a control transformer and power factor correction capacitor. For this custom circuit, these options are not needed and the marker blocks can be removed.

- 1 To verify which marker block is for the control transformer, switch over to *ace\_circuit\_builder.xls*.
- 2 Open the ACE\_CIRCS worksheet.

Find which circuit codes sheet is used for the original template you copied over, *ace\_cb1\_FVNR\_H.dwg*.
- 3 Locate a row with the name of the original template you copied over, *ace\_cb1\_FVNR\_H.dwg*, in the DWG\_TEMPLATE field.
- 4 Find the SHEET\_NAME value for this row, **3ph\_H**.

- 5 Open the 3ph\_H worksheet.
- 6 Find the entry for Control transformer and circuit - non-reversing in the COMMENTS column.
- 7 Find the CODE value for this row, **XF01**.  
This CODE value links the marker block to the circuit code sheet.
- 8 Switch back to the drawing and locate the marker block with the CODE value of XF01.
- 9 Erase the marker block using the AutoCAD ERASE command.
- 10 Repeat the steps to locate and delete the power factor correction marker block, CODE=KVARI.

### Add a marker block

You can add a marker block by inserting the library symbol, ace\_cb\_marker\_block.dwg, or by copying an existing marker block and modifying the attribute values. In this section, you will insert a marker block that directs Circuit Builder to display a list of possible components to insert in the Circuit Configuration dialog box.

---

**NOTE** This exercise demonstrates the capabilities of Circuit Builder and the result may not necessarily be electrically valid.

---

- 1 Determine exactly where in the template you want this specific component inserted as the circuit is built.
- 2 Enter *INSERT* at the command line to launch the AutoCAD block insert command.
- 3 Browse to ace\_cb\_marker\_block.dwg and insert this block at the desired location.  
A copy of this block is installed in each of the schematic library folders, JIC125, IEC2, and so on.

---

**NOTE** You could also use the AutoCAD COPY command and copy a nearby marker block into the desired location.

---

- 4 Enter *ATTEDIT* and select the marker block.
- 5 Enter a value for the CODE attribute, for example **USR001**.



Use letters or numbers for the value. There is no code naming convention. Make sure it is unique within the circuit codes spreadsheet. This marker block code value maps a row or group of rows in to the spreadsheet. The information in the spreadsheet directs Circuit Builder to perform a specific action at the XY coordinate of this marker block.

- 6 Enter a value for the ORDER attribute, for example **12**.

This value can be an integer or decimal number and defines the order that the marker blocks are processed. In this example, 12 is the highest ORDER value on the template. This means that the action defined by this marker block is the last one processed as the circuit is built.

- 7 Enter an optional value for the MISC1 attribute, such as **LOC=FIELD;DESC1=ADDED COMPONENT**.

This value can carry a number of [flags](#) on page 2010 as well as predefine attribute values. When more than one, they are to be semi-colon delimited.

### Modify existing marker block

The template has a marker block with a CODE value of X001. Finding the matching code in the circuit codes sheet indicates a multi-pole component insertion. Three terminals are inserted at the location of this marker block. In this section, you add a MISC1 value to predefine the terminal numbers.

- 1 Enter *ATTEDIT* and select the marker block with the CODE value of X001.
- 2 Enter **\_L=|TERM01=T1|TERM01=T2|TERM01=T3|**.

This "\_L=" prefix marks the beginning of a list of data to annotate on to a multi-pole insertion triggered by the single marker block. In the example here, a multi-pole insertion of three terminals into the three phase bus defined in the template drawing.

The "|" symbol separates the attribute groups for each pole of the multi-pole insertion. Multiple attributes within a group are separated by a ";", the second-level delimiter. This example directs Circuit Builder to assign T1 to the TERM01 attribute on the first terminal inserted, T2 on the second, and T3 on the third.

---

**NOTE** See [Assign different attribute values on a multi-pole insert](#) on page 2045 for more information.

---

- 3 Click OK.

---

**NOTE** Save the circuit template drawing after all the modifications are made.

---

## ACE\_CIRCS sheet

The ACE\_CIRCS sheet in the ace\_circuit\_builder.xls spreadsheet controls the circuit options displayed on the Circuit Selection dialog box. In this exercise, you add entry to this ACE\_CIRCS sheet so your new circuit option shows up in the Circuit Selection dialog box.

- 1 Open ace\_circuit\_builder.xls for edit using a spreadsheet software. See [Circuit Builder spreadsheet overview](#) on page ? for the location of this file.
- 2 Open the ACE\_CIRCS sheet.  
The structure of this sheet controls the tree structure used by Circuit Builder on the Circuit Selection dialog box. You will add a new category, “Custom Circuits”, with one custom circuit option, “My 3-ph motor”, within that category.
- 3 Enter **Custom Circuits** in the CATEGORY field of the first blank row below the existing entries.  
It adds a new category to the highest level of the tree display.
- 4 Enter **My 3-ph motor** in the TYPE field for the same row.  
It adds an option within this new category.
- 5 Enter **ace\_cb1\_FVNR\_H\_custom.dwg** in the DWG\_TEMPLATE field in this row.  
It defines which circuit template drawing to use for this option. This is the circuit template drawing created in the [Create the circuit template](#) on page 2032 exercise.
- 6 Enter **3ph\_H\_custom** in the SHEET\_NAME field in this row.  
It defines the circuit codes sheet name. This is created in the [Circuit codes sheet](#) on page 2039 exercise.
- 7 Save the spreadsheet.

---

**NOTE** Leave the ANNO\_CODE field blank. See [Predefine attribute values using annotation presets](#) on page 2072 to learn how to define annotation.

---

## Circuit codes sheet

Once a circuit is selected from the Circuit Selection dialog box (the CATEGORY and TYPE fields from the ACE\_CIRC sheet), the associated circuit template drawing, with the marker blocks, is inserted (the DWG\_TEMPLATE field). A related circuit code sheet is ready for reference (the SHEET\_NAME field). Each marker block contains a CODE attribute with a value. This CODE value is used to match up with a section in the circuit code sheet which defines what to do at the location of this marker block in the template.

You can create a sheet or copy an existing, similar sheet. Since the circuit template drawing was copied from ace\_cb1\_FVNR\_H.dwg, it is easier to copy the circuit codes sheet, 3ph\_H, and modify it.

- 1 Open ace\_circuit\_builder.xls for edit using a spreadsheet software. See [Circuit Builder spreadsheet overview](#) on page ? for the location of this file.
- 2 Copy the 3ph\_H sheet and rename it 3ph\_H\_custom as referenced in the ACE\_CIRCS sheet.

The changes in the circuit codes sheet must correspond to the changes made to the marker blocks in the circuit template drawing. You can delete the lines in the sheet that match the code values from the marker blocks you deleted, XF01 and KVAR1. If you decide not to delete them from this sheet, it is not a problem. These lines are ignored and not displayed on the Circuit Configuration dialog box if the corresponding marker blocks are not found.

- 3 Locate the CODE value XF01.
- 4 Delete all the spreadsheet rows to the point where the next non-blank CODE value begins, such as XF02.
- 5 Repeat for CODE value KVAR1.

Add a section for the new marker block you added with a CODE value of USR001. Add this new section at the bottom of the sheet after the last non-blank row.

- 6 Enter **USR001** in the CODE field in the blank row.
- 7 Enter **Extra Component** in the COMMENT field.  
It is displayed in the left-hand Circuit Elements section of the Circuit Configuration dialog box and is used for selection.
- 8 Enter **Component** in the UI\_TITLE field.

It is the label that shows up above the selection list in the middle part of the Circuit Configuration dialog box.

- 9 Enter **Red Light** in the UI\_PROMPT\_LIST field in the same row.

It is the text shown in the selection list for this item, displayed in the middle part of the dialog box.

- 10 Enter '1 in the UI\_VAL field in the same row.

It is a numerical value assigned to the selection from each group. These numerical values are added up and matched to the value in the UI\_SEL column. This example only has one value.

- 11 Enter '1 in the UI\_SEL field in the same row.

---

**NOTE** All UI\_VAL and UI\_SEL values must be inserted as text values in the spreadsheet and not as numbers. An apostrophe character in front of the number forces the spreadsheet software to interpret it as a text value. You can also format the cells specifically as text. The text should appear left justified in the cell. If any values appear right justified, they must change from numeric to text values.

---

It is a numerical value matched to the sum total of the values in the UI\_VAL column for each selection made within a group. The COMMAND\_LIST value from this row is used to insert the selected options.

- 12 Enter (c:ace\_cb\_insym #xyz nil "HLT1R" #scl 8 nil) in the COMMAND\_LIST field.

It is the API call Circuit Builder uses to insert a component. See the API documentation for more information.

- 13 Enter **Selector Switch** in the UI\_PROMPT\_LIST field in the next row.

It is the second option within the Extra Component option. The CODE, COMMENTS, and UI\_TITLE fields should remain blank.

- 14 Enter **X** in the UI\_DEF field in this row. It defines the entry as the default option. The default is used when the circuit is inserted using the Insert button on the Circuit Selection dialog box. If the Configure button is selected, the "X" entry is the preselected default in the Circuit Configuration dialog box when the options for this marker block are displayed

- 15 Enter '2 in the UI\_VAL field in the same row.

- 16 Enter '2 in the UI\_SEL field in the same row.

- 17 Enter **(c:ace\_cb\_insym #xyz nil "HSS112" #scl 8 nil)** in the COMMAND\_LIST field.
  - 18 Enter **NO Contact** in the UI\_PROMPT\_LIST field in the next row.
  - 19 Enter **'3** in the UI\_VAL field in the same row.
  - 20 Enter **'3** in the UI\_SEL field in the same row.
  - 21 Enter **(c:ace\_cb\_insym #xyz nil "HCR21" #scl 8 nil)** in the COMMAND\_LIST field.
  - 22 Enter **None** in the UI\_PROMPT\_LIST field in the next row.
  - 23 Enter **'0** in the UI\_VAL field in the same row.
  - 24 Enter **'0** in the UI\_SEL field in the same row.
- Leave the COMMAND\_LIST field blank, meaning that if this option is selected no action is needed.

1	CODE	COMMENTS	UI_D UI_TITLE	UI_PROMPT_LIST	UI_VAL	UI_SEL	COMMAND_LIST
149							
150	USR001	Extra component	Component	Red Light	1	1	(c:ace_cb_insym #xyz nil "HLT1R" #scl 8 nil)
151		X		Selector Switch	2	2	(c:ace_cb_insym #xyz nil "HSS112" #scl 8 nil)
152				NO Contact	3	3	(c:ace_cb_insym #xyz nil "HCR21" #scl 8 nil)
153				None	0	0	

- 25 Save the spreadsheet.

---

**NOTE** A new circuit codes sheet is not always needed. Depending on the circuit and the circuit options, the information can be added to an existing sheet. In this example, a new sheet was created to demonstrate the procedure.

---

## Testing the circuit

Once you create the [circuit template](#) on page 2032, modified [ACE\\_CIRCS](#) on page 2038 sheet, and added the [circuit codes](#) on page 2039 sheet, you are ready to test your custom circuit.

- 1 Make sure that you save the spreadsheet changes and close the spreadsheet file.
- 2 Open a new or existing drawing to insert the circuit. Make sure that the drawing has a vertical 3-phase bus.
- 3 Click Schematic tab ► Insert Components panel ► Circuit Builder



drop-down ► Circuit Builder.

- 4 Look for the new category you added, **Custom Circuits**, on the Circuit Selection dialog box.  
If it is not there, or is not in the place you wanted, go back to the [ACE\\_CIRCS](#) on page 2038 exercise.
- 5 Expand the Custom Circuits category and select the circuit you added, **My 3-ph motor**.  
If it is not there or is not in the place you wanted, go back to the [ACE\\_CIRCS](#) on page 2038 exercise.
- 6 Click Configure.
- 7 Select a location on the 3-phase bus.  
If the wires do not connect to the bus in the way defined, go back to [Define wires stretching to connect to bus](#) on page 2034.
- 8 Look through the circuit elements on the Circuit Configuration dialog box. If the circuit element for the new marker block, **Extra Component**, is not there, go back to [Circuit codes sheet](#) on page 2039.
- 9 Select **Extra Component** in Circuit Elements.  
If the options, Red Light, Selector Switch, NO Contact, and None are not displayed in the Select section, go back to [Circuit codes sheet](#) on page 2039.  
  
If the default value for the Extra Component is not **Selector Switch**, go back to [Circuit codes sheet](#) on page 2039.
- 10 Select a component from the list.
- 11 Select to insert all the circuit elements. 
- 12 If the component selected for the new Extra Component option was not inserted, go back to [Circuit codes sheet](#) on page 2039.
- 13 If the attribute values for the component are not predefined, LOC=FIELD and DESC1=ADDED COMPONENT, go back to [circuit template](#) on page 2032.
- 14 If the three terminals are not numbered, T1, T2, and T3, go back to [circuit template](#) on page 2032.

# Circuit Builder - How to

## Overview

Circuit Builder is controlled by a spreadsheet, a set of circuit template drawings, and the electrical standards database file. The spreadsheet, circuit template drawings, and the electrical standards database file can be modified to customize Circuit Builder.

### Spreadsheet

The spreadsheet defines the available circuits, circuit types, and defaults for each option within a circuit. The default name for the Circuit Builder spreadsheet is `ace_circuit_builder.xls`. The default location for the spreadsheet is:

- **Windows XP:** `C:\Documents and Settings\All Users\Documents\Autodesk\AcadE {version}\Support\`
- **Windows Vista, Windows 7:** `C:\Users\Public\Documents\Autodesk\AcadE {version}\Support\`

The `ace_circuit_builder.xls` spreadsheet can be relocated into any of the normal AutoCAD Electrical or AutoCAD support paths.

The circuit builder spreadsheet name can be overridden by setting the environment variable, `WD_CIRCBUILDER_FNAM`, in the [wd.env](#) on page 1984 file.

### circuit template drawings

The template for a selected circuit defines the placement for the individual components and the wiring. The circuit template drawings use the following naming convention.

- `ace_cb1_*.dwg` - primary circuit template drawings
- `ace_cb2_*.dwg` - branching or nested circuit template drawings

The default location for the circuit template drawings is the schematic library folder:

- **Windows XP:** `C:\Documents and Settings\All Users\Documents\Autodesk\AcadE {version}\Libs\{library}\`

- **Windows Vista, Windows 7:** C:\Users\Public\Documents\Autodesk\AcadE {version}\Libs\{library}\

One-line circuit templates have a “1-” and the default location is in a “1-” folder under the schematic library folder.

- **Windows XP:** C:\Documents and Settings\All Users\Documents\Autodesk\AcadE {version}\Libs\{library}\1-
- **Windows Vista, Windows 7:** C:\Users\Public\Documents\Autodesk\AcadE {version}\Libs\{library}\1-

---

**NOTE** New templates do not have to follow this naming convention.

---

### Electrical Standards database file

Circuit Builder uses an electrical standards database to define default values, define engineering calculations, annotate circuits, and provide wire type analysis. The electrical standards database, ace\_electrical\_standards.mdb, is located in the catalog folder. The default location is:

- **Windows XP:** C:\Documents and Settings\{username}\My Documents\Acade {version}\AeData\Catalogs\
- **Windows Vista, Windows 7:** C:\Users\{username}\Documents\Acade {version}\AeData\Catalogs\

### See also:

- [Circuit Builder spreadsheet](#) on page 2006
- [Circuit Builder drawing templates](#) on page 2010
- [Circuit Builder database](#) on page 2015

### Add a multiple catalog option

Some components need multiple catalog entries. Define them in the Circuit Builder spreadsheet to add them in the Setup & Annotation section of the Circuit Configuration dialog box.

- 1 Open the Circuit Builder spreadsheet, ace\_circuit\_builder.xls.
- 2 Find the circuit CATEGORY and TYPE, for example **CATEGORY:** 3ph Motor Circuit and **TYPE:** Horizontal - FVNR - non reversing.



- 3 Open the circuit code sheet with the same name as the SHEET\_NAME value, for example **SHEET\_NAME**: 3ph\_H.
- 4 Find the component, for example **CODE**: PB01, **COMMENTS**: Stop, **UI\_PROMPT\_LIST**: Stop.  
Notice the values in **TABLE0**: PB and **TITLE0**: Push Button.  
It indicates that the component can have a main catalog value. The TABLE0 value is the table name for the catalog lookup. The TITLE0 value is the title for the section in the Setup & Annotation area of the Circuit Configuration dialog box.
- 5 Add a value in the TABLE1 and TITLE1 cells. For example, if the push button requires a cover and it is found in the MISC\_CAT table of the catalog lookup database file, enter **TABLE1**: MISC\_CAT and **TITLE1**: Cover.
- 6 Save the spreadsheet.

The next time Circuit Builder is run using the configure option, an extra catalog section appears for this component.

### Assign different attribute values on a multi-pole insert

There are two ways to predefine attribute values for a multi-pole component.

- On the marker block for the component in the circuit template drawing.
- In the Circuit Builder spreadsheet circuit codes sheet.

---

**NOTE** The attribute value defined on the marker block overrides any value defined in the spreadsheet.

---

#### Marker block method

- 1 Open the circuit template drawing that contains the marker block for the component.
- 2 Find the correct marker block for the component.
- 3 Edit its MISC1 attribute value using the format “\_L={attribute name}={attribute value} | {attribute name}={attribute value}”. For example, to assign different terminal numbers to the multi-pole insertion of three motor terminals, enter “\_L=|TERM01=T1|TERM01=T2|TERM01=T3|”.

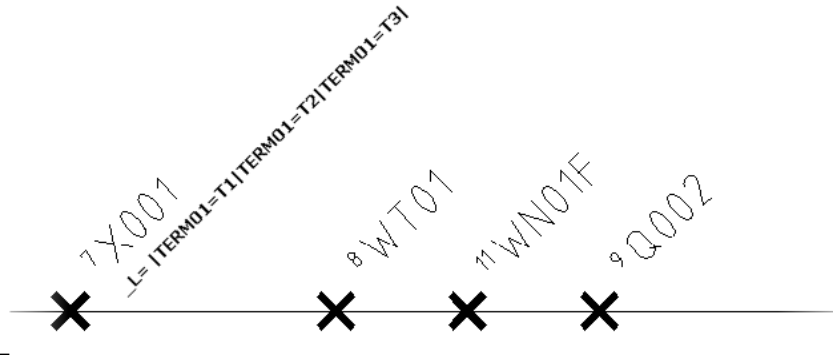

**NOTE** The MISC1 attribute value can contain multiple special text flags which direct Circuit Builder to handle the component or underlying wire in a special way. When you add new values, do not overwrite any other special flag values. Separate each one with a semicolon.

- 4 Save the circuit template drawing.

### Spreadsheet method

- 1 Open the Circuit Builder spreadsheet, ace\_circuit\_builder.xls.
- 2 Find the circuit CATEGORY and TYPE, for example **CATEGORY:** 3ph Motor Circuit and **TYPE:** Horizontal - FVNR - non reversing.
- 3 Open the circuit code sheet with the same name as the SHEET\_NAME value, for example **SHEET\_NAME:** 3ph\_H.
- 4 Find the specific component, for example **CODE:** X001, **COMMENTS:** Motor terminal connections, **UI\_PROMPT\_LIST:** Square.

There can be multiple selections within the group. For example, there is a selection for the type of disconnecting means, and a selection to include an auxiliary contact. Each selection is assigned a numerical value from the UI\_VAL field. The values are added to determine the appropriate action for this combination of selections. The sum is matched to a value in the UI\_SEL field. Once this match is made, the COMMAND\_LIST value, ANNOTATE\_LIST value, and so on, are used to insert and annotate the selections.

- 5 Edit the API call in the COMMAND\_LIST column for this component. For example, the last argument of this Insert Multi-pole Component API call is used to predefine MISC1 coded values with nil when nothing extra is defined.

Before and after are shown:

**Before:** (c:ace\_cb\_multipole #xyz nil "HT0001" 3 #scl 4 nil)

**After:** (c:ace\_cb\_multipole #xyz nil "HT0001" 3 #scl 4  
"\_L=|TERM01=T1|TERM01=T2|TERM01=T3|")

---

**NOTE** See the API documentation for more information.

---

- 6 Save the spreadsheet.

## Assign attribute values using AutoLISP

An AutoLISP expression can be used to define a calculated or special value for an attribute on a component. For example, you can calculate related values such as Kilowatt (KW) based upon a selected horsepower value.

See [Map motor parameters to the motor symbol attributes](#) on page 2063 to map the entered horsepower.

- 1 Open the circuit template drawing that contains the marker block for the motor symbol.
- 2 Find the correct marker block for the motor symbol.
- 3 Edit its MISC1 attribute value using the format "{attribute name}=(AutoLISP expression). For example, convert the HP value to Kilowatts and push this value out to attribute RATING5 on the motor symbol. Enter this expression on the MISC1 attribute of the marker block:  
RATING5=(rtos (\* @1@ 0.746) 2 2)

The "@1@" maps to the second entry (list is zero based) held in the #data global variable, which is the entered horsepower value. Multiplying by 0.746 converts the horsepower (HP) to Kilowatts (KW).

**X** MTR03  
RATING5=(rtos(\* @1@ 0.746) 2 2)

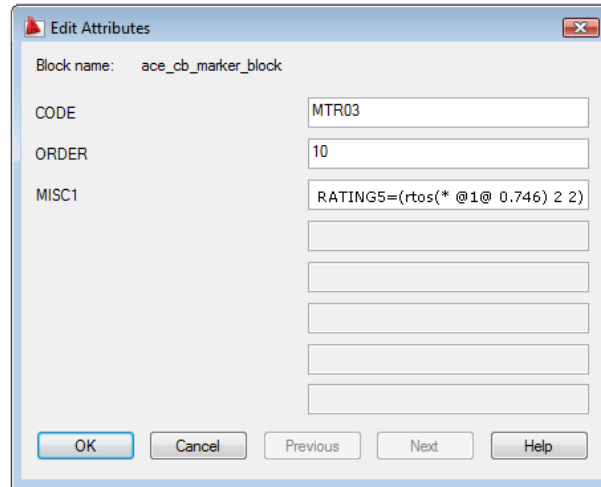

---

**NOTE** The MISC1 attribute value can contain multiple special text flags which direct Circuit Builder to handle the component or underlying wire in a special way. When you add new values, do not overwrite any other special flag values. Separate each one with a semicolon.

---

- 4 Save the circuit template drawing.

### Conditionally trim or remove a wire segment

As Circuit Builder dynamically builds the circuit, a circuit element selection can require that a wire is trimmed back or removed. For example, the circuit can include an option for an indicator light. If no indicator light is selected, the wire framework for it must be removed.

- 1 Open the circuit template drawing that contains the marker block for the optional component. Take note of the value of the ORDER attribute.
- 2 Find the wires to remove or trim if the optional component is not selected.
- 3 Add marker blocks on each wire with the same ORDER attribute value as the optional marker block for the component.
- 4 Assign the same CODE value to each trim wire marker block, for example "XY01".

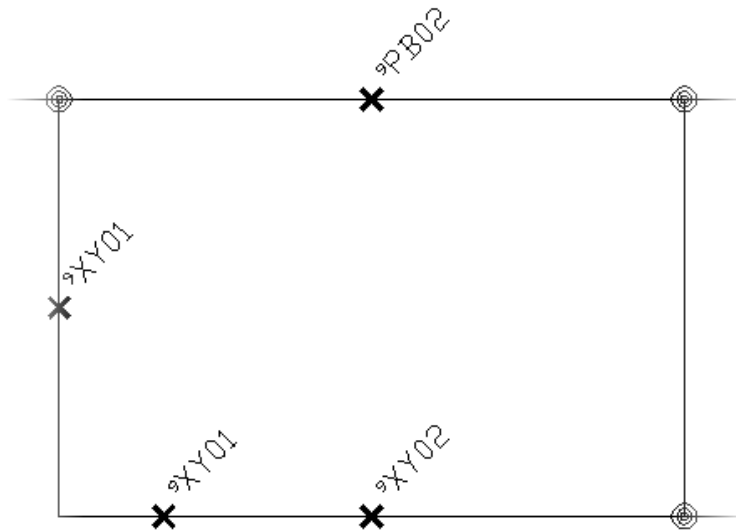

- 5 Save the circuit template drawing.
- 6 Open the Circuit Builder spreadsheet, ace\_circuit\_builder.xls.
- 7 Find the circuit CATEGORY and TYPE, for example **CATEGORY:** 3ph Motor Circuit and **TYPE:** Horizontal - FVNR - non reversing.
- 8 Open the circuit code sheet with the same name as the SHEET\_NAME value, for example **SHEET\_NAME:** 3ph\_H.
- 9 Find the optional component, for example **CODE:** LT01, **COMMENTS:** Light, **UI\_PROMPT\_LIST:** Light.
- 10 Edit the API call in the COMMAND\_LIST column for the option that would require a wire trim or removal. For example, add this command call for the "No light" option in the spreadsheet:  
(c:ace\_cb\_trim "XY01" nil) where "XY01" is the CODE attribute value assigned to each wire marker block.

---

**NOTE** See the API documentation for more information.

---

- 11 Save the spreadsheet.

## Conditional component insertion

As Circuit Builder dynamically builds the circuit, a circuit element selection may require a conditional component insertion. For example, there may be an option to insert either a “start” push button or a N.O. relay contact at the insertion point of a marker block. If a momentary push button is selected then a “seal” contact should be inserted around the push button at the location marked with a separate marker block. However, if the N.O. relay contact option is selected, then no seal contact is needed and wires must be trimmed or removed.

- 1 Open the circuit template drawing that contains the marker block for the selected component, for example the momentary push button. Take note of the value of its ORDER attribute.
- 2 Find the wire that should receive the conditional component. Add a marker block with the same ORDER attribute value.
- 3 Assign a unique CODE attribute value to this conditional marker block, for example “XY02”.
- 4 Find the wires to remove or trim if the conditional component is not needed.
- 5 Add marker blocks on each of these wire segments. Edit the ORDER attribute value to match the one on the marker block for the conditional component.
- 6 Assign the same CODE value to each wire marker block, for example “XY01”. This CODE value should not be the same as the one assigned to the conditional component marker block.

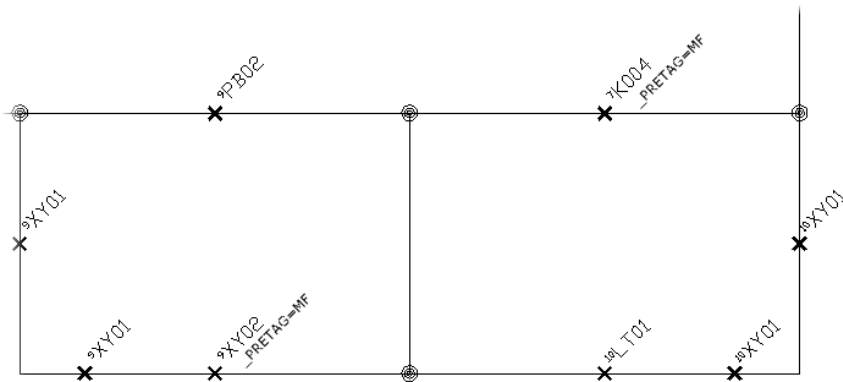

- 7 Save the circuit template drawing.

- 8 Open the Circuit Builder spreadsheet, ace\_circuit\_builder.xls.
- 9 Find the circuit CATEGORY and TYPE, for example **CATEGORY:** 3ph Motor Circuit and **TYPE:** Horizontal - FVNR - non reversing.
- 10 Open the circuit code sheet with the same name as the SHEET\_NAME value, for example **SHEET\_NAME:** 3ph\_H.
- 11 Find the optional component, for example **CODE:** PB02, **COMMENTS:** Start, **UI\_PROMPT\_LIST:** Start.
- 12 Edit the API call in the COMMAND\_LIST column for the option that would require the conditional insert. Multiple API calls can be used to insert multiple components. For example:  

```
(c:ace_cb_insym #xyz nil "HPB11" #scl 8 nil)(c:ace_cb_insym "XY02" nil "HMS21" #scl 8 nil)
```

Note the difference in the second call. Instead of passing the #xyz global variable name that carries the XY coordinate of the main marker block, it passes the "XY02" code name. This means that the "HMS21" symbol will insert wherever marker block "XY02" is located in the inserted template.
- 13 Edit the API call in the COMMAND\_LIST column for the option that requires a wire trim or removal. For example:  

```
(c:ace_cb_trim "XY01" nil)
```

where "XY01" is the CODE attribute value assigned to each wire marker block.

Instead of passing the XY coordinate as the first argument, the "XY01" code name is passed. It instructs Circuit Builder to find all marker blocks with CODE attribute value "XY01" and with the target ORDER value and trim or remove their underlying wires

---

**NOTE** See the API documentation for more information.

---

- 14 Save the spreadsheet.

## Control the multi-pole insertion direction

The default build direction for a multi-pole component is down for horizontal bus wires, and left to right for vertical bus wires. You can override the default build direction.

- 1 Open the circuit template drawing that contains the marker block for the multi-pole component.
- 2 Find the correct marker block for the component.

- 3 Edit its MISC1 attribute value using the format “\_D={digit}”, where 1=build left to right, 2=build up, 4=build right to left, and 8=build down.

For example, if the template has a vertical 3-phase bus and the disconnection means that marker block is located over the right-hand wire, give its MISC1 attribute a value of “\_D=4”. It causes the child poles of the multi-pole insert to move to the left to pick up the remaining two bus wires.

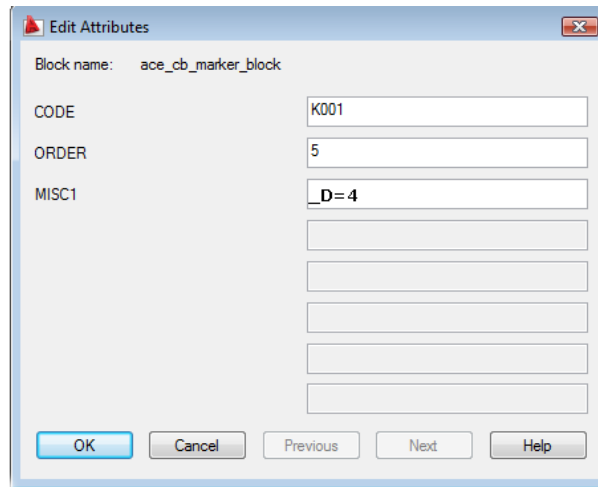

---

**NOTE** The MISC1 attribute value can contain multiple special text flags which direct Circuit Builder to handle the component or underlying wire in a special way. When you add new values, do not overwrite any other special flag values. Separate each one with a semicolon.

---

- 4 Save the circuit template drawing.

## Control the bus wire spacing

You can set up a circuit template so the wire spacing between two or more parallel bus wires is auto-adjusted. A marker block is positioned on each wire and its CODE value references the (c:ace\_cb\_rung\_spacing...) API call in the spreadsheet. The marker blocks with a common ORDER value are processed as a group. One of the marked wires is designated as the "base" wire, meaning that it is the one that does not move. The other marked bus wires in the group are then positioned set distances away from the base wire.



The base wire is determined in one of two ways:

- The base wire is the marker block that has a MISC1 attribute with a value of "\_BASE".
- If no MISC1 attribute has a "\_BASE" value, the underlying wire that comes closest to being colinear with the insertion point of the template is the one that becomes the base wire.

A template can carry multiple groups of marker blocks indicating that the underlying bus wires should auto-adjust. The CODE value can be the same for all groups, but each group must have its own ORDER value.

## Define the wire type

There are three ways to define the wire type.

- On the marker block for the wire in the circuit template.
- In the Circuit Builder spreadsheet circuit codes sheet.
- Based on motor size selection.

---

**NOTE** The attribute value defined on the marker block overrides any value defined in the spreadsheet.

---

### Marker block method

- 1 Open the circuit template drawing that contains the marker block for the wire.
- 2 Find the correct marker block for the wire.
- 3 Edit its MISC1 attribute value using the format "\_WIRETYPE={layer name}", for example, "\_WIRETYPE=BRN\_10AWG".

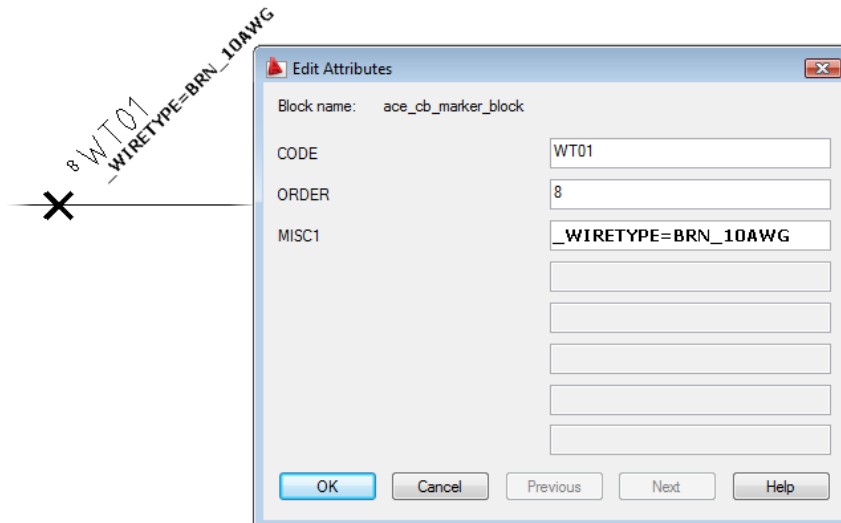

---

**NOTE** The MISC1 attribute value can contain multiple special text flags which direct Circuit Builder to handle the component or underlying wire in a special way. When you add new values, do not overwrite any other special flag values. Separate each one with a semicolon.

---

- 4 Save the circuit template drawing.

### Spreadsheet method

- 1 Open the Circuit Builder spreadsheet, ace\_circuit\_builder.xls.
- 2 Find the circuit CATEGORY and TYPE, for example **CATEGORY:** 3ph Motor Circuit and **TYPE:** Horizontal - FVNR - non reversing.
- 3 Open the circuit code sheet with the same name as the SHEET\_NAME value, for example **SHEET\_NAME:** 3ph\_H.
- 4 Find the specific wire, for example **CODE:** WT01, and **COMMENTS:** Assign motor wire type - phase 1.
- 5 Edit the API call in the COMMAND\_LIST column for this wire. For example, the last argument of this Set Wire type API call is used to predefine MISC1 coded values with nil when nothing extra is defined. Before and after are shown:

**Before:** (c:ace\_cb\_set\_wiretype #data 1 nil nil)

**After:**(c:ace\_cb\_set\_wiretype #data 1 nil “\_WIRETYPE=BRN\_10AWG”)

---

**NOTE** See the API documentation for more information.

---

- 6 Save the spreadsheet.

### Based on motor size selection

You can apply the minimum wire size for a selected motor load to the wire type layer name. The value, which is extracted from the ace\_electrical\_standards.mdb database, can be substituted for any “@WSIZE@” string found in the “\_WIRETYPE=” value. Use this variable in the MISC1 attribute on the wire marker block or in the spreadsheet as part of the wire type API call.

### Marker block method

- 1 Open the circuit template drawing that contains the marker block for the wire.
- 2 Find the correct marker block for the wire.
- 3 Edit its MISC1 attribute value using the format “\_WIRETYPE=@WSIZE@”, for example, “\_WIRETYPE=BRN\_@WSIZE@”.

---

**NOTE** The MISC1 attribute value can contain multiple special text flags which direct Circuit Builder to handle the component or underlying wire in a special way. When you add new values, do not overwrite any other special flag values. Separate each one with a semicolon.

---

- 4 Save the circuit template drawing.

### Spreadsheet method

- 1 Open the Circuit Builder spreadsheet, ace\_circuit\_builder.xls.
- 2 Find the circuit CATEGORY and TYPE, for example **CATEGORY:** 3ph Motor Circuit and **TYPE:** Horizontal - FVNR - non reversing.
- 3 Open the circuit code sheet with the same name as the SHEET\_NAME value, for example **SHEET\_NAME:** 3ph\_H.
- 4 Find the specific wire, for example **CODE:** WT01, and **COMMENTS:** Assign motor wire type - phase 1.

- 5 Edit the API call in the COMMAND\_LIST column for this wire. For example, the last argument of this Set Wire type API call is used to predefine MISC1 coded values with nil when nothing extra is defined.

Before and after are shown:

**Before:** (c:ace\_cb\_set\_wiretype #data 1 nil nil)

**After:**(c:ace\_cb\_set\_wiretype #data 1 nil “\_WIRETYPE=BRN\_@WSIZE@”)

---

**NOTE** See the API documentation for more information.

---

- 6 Save the spreadsheet.

## Define the wire type as no wire numbering

There are two ways to define the wire type and set it to “no wire numbering”.

- On the marker block for the wire in the circuit template.
- In the Circuit Builder spreadsheet circuit codes sheet.

---

**NOTE** The attribute value defined on the marker block overrides any value defined in the spreadsheet.

---

### Marker block method

- 1 Open the circuit template drawing that contains the marker block for the wire.
- 2 Find the correct marker block for the wire.
- 3 Edit its MISC1 attribute value using the format “\_WIRENUMBERS=0;\_WIRETYPE={layer name}”.
  - \_WIRENUMBERS=0 defines the layer as No Wire Numbering. Any wire without this flag is created as a normal wire numbering layer by default.

---

**NOTE** This flag applies only if the wire layer does not exist and is created when the circuit is inserted.

---

- \_WIRETYPE={layer name} defines the layer name.

---

**NOTE** The MISC1 attribute value can contain multiple special text flags which direct Circuit Builder to handle the component or underlying wire in a special way. When you add new values, do not overwrite any other special flag values. Separate each one with a semicolon.

---

- 4 Save the circuit template drawing.

### Spreadsheet method

- 1 Open the Circuit Builder spreadsheet, ace\_circuit\_builder.xls.
- 2 Find the circuit CATEGORY and TYPE, for example **CATEGORY:** 3ph Motor Circuit and **TYPE:** Horizontal - FVNR - non reversing.
- 3 Open the circuit code sheet with the same name as the SHEET\_NAME value, for example **SHEET\_NAME:** 3ph\_H.
- 4 Find the specific wire, for example **CODE:** WT01, and **COMMENTS:** Assign motor wire type - phase 1.
- 5 Edit the API call in the COMMAND\_LIST column for this wire. For example, the last argument of this Set Wire type API call is used to predefine MISC1 coded values with nil when nothing extra is defined. Before and after are shown:

**Before:** (c:ace\_cb\_set\_wiretype #data 1 nil nil)

**After:**(c:ace\_cb\_set\_wiretype #data 1 nil  
“\_WIRENUMBERS=0;\_WIRETYPE=BRN\_10AWG”)

- **\_WIRENUMBERS=0** defines the layer as No Wire Numbering. Any wire without this flag is created as a normal wire numbering layer by default.

---

**NOTE** This flag applies only if the wire layer does not exist and is created when the circuit is inserted.

---

- **\_WIRETYPE=BRN\_10AWG** defines the layer name.

---

**NOTE** See the API documentation for more information.

---

- 6 Save the spreadsheet.

## Format the numeric tag of the motor symbol in a wire number

You can include the motor symbol tag number assignment in connected wire number assignments. It requires coordination between the motor symbol insertion and the wire number insertion. The motor symbol must insert before the wire number. The order of insertion is controlled by the ORDER attribute value on the marker blocks within the circuit template drawing. The marker block ORDER attribute value for the motor symbol must be a lower number than the ORDER value of the marker block for the wire number in the circuit template drawing. When the wire number is inserted, the motor tag value can be incorporated in to the wire number.

- 1 Open the Circuit Builder spreadsheet, `ace_circuit_builder.xls`.
- 2 Find the circuit CATEGORY and TYPE, for example **CATEGORY:** 3ph Motor Circuit and **TYPE:** Horizontal - FVNR - non reversing.
- 3 Open the circuit code sheet with the same name as the SHEET\_NAME value, for example **SHEET\_NAME:** 3ph\_H.
- 4 Find the motor symbol, for example **CODE:** MTR03, **COMMENTS:** Motor symbol, **UI\_PROMPT\_LIST:** 3ph motor.

There can be multiple selections within the group. For example, there is a selection for the type of disconnecting means, and a selection to include an auxiliary contact. Each selection is assigned a numerical value from the UI\_VAL field. The values are added together to determine the appropriate action for this combination of selections. The sum is matched to a value in the UI\_SEL field. Once this match is made, the COMMAND\_LIST value, ANNOTATE\_LIST value, and so on, are used to insert and annotate the selections.

- 5 Edit the API call in the ANNOTATE\_LIST column for this component. For example, it might look like this with two API calls concatenated:  
(c:ace\_cb\_anno #data 0)(c:ace\_cb\_save "@MOTOR\_NUM@" "TAG1\*" nil 1)

The second one, `c:ace_cb_save`, saves the TAG1 attribute value on the motor in to memory under an index tag of `"@MOTOR_NUM@"`. This value can be referenced when the subsequent wire number marker blocks are processed.

---

**NOTE** See the API documentation for more information on `c:ace_cb_save`.

---

- 6 Save the spreadsheet.

- 7 Find the marker blocks for the wire numbers that are tied to the motor tag. These could be on the main circuit template or on a nested template drawing. Open the circuit template drawing.
- 8 Find the correct marker block for the wire number.
- 9 Edit its MISC1 attribute value using the @MOTOR\_NUM@ in the format where you want the motor tag value. For example, “\_TAGFMT=@MOTOR\_NUM@-%N” or to predefine a wire number, “\_TAGFMT=@MOTOR\_NUM@-T1A”.

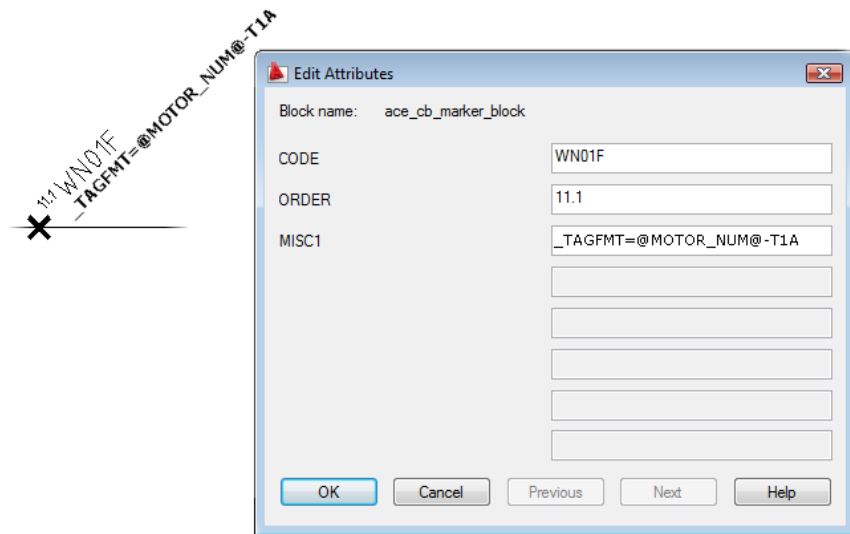

**NOTE** The MISC1 attribute value can contain multiple special text flags which direct Circuit Builder to handle the component or underlying wire in a special way. When you add new values, do not overwrite any other special flag values. Separate each one with a semicolon.

- 10 Save the circuit template drawings.

### Format the numeric tag of the motor symbol into other component tags

You can include the motor symbol tag number assignment in other components in the circuit. It requires coordination between the motor symbol insertion and the insertion of the other components. The motor symbol must

insert before these other components. The order of insertion is controlled by the ORDER attribute value on the marker blocks within the circuit template drawing. The marker block ORDER attribute value for the motor symbol must be a lower number than the ORDER values of the marker blocks for the other components in the circuit template drawing. When the other components are inserted, the motor tag value can be incorporated into the subsequent component tags.

- 1 Open the Circuit Builder spreadsheet, ace\_circuit\_builder.xls.
- 2 Find the circuit CATEGORY and TYPE, for example **CATEGORY:** 3ph Motor Circuit and **TYPE:** Horizontal - FVNR - non reversing.
- 3 Open the circuit code sheet with the same name as the SHEET\_NAME value, for example **SHEET\_NAME:** 3ph\_H.
- 4 Find the motor symbol, for example **CODE:** MTR03, **COMMENTS:** Motor symbol, **UI\_PROMPT\_LIST:** 3ph motor.

There can be multiple selections within the group. For example, there is a selection for the type of disconnecting means, and a selection to include an auxiliary contact. Each selection is assigned a numerical value from the UI\_VAL field. The values are added together to determine the appropriate action for this combination of selections. The sum is matched to a value in the UI\_SEL field. Once this match is made, the COMMAND\_LIST value, ANNOTATE\_LIST value, and so on, are used to insert and annotate the selections.

- 5 Edit the API call in the ANNOTATE\_LIST column for this component. For example, it might look like this with two API calls concatenated:  
(c:ace\_cb\_anno #data 0)(c:ace\_cb\_save "@MOTOR\_NUM@" "TAG1\*" nil 1)

The second one, c:ace\_cb\_save, saves the TAG1 attribute value on the motor in to memory under an index tag of "@MOTOR\_NUM@". This value can be referenced when the subsequent component marker blocks are processed.

---

**NOTE** See the API documentation for more information on c:ace\_cb\_save.

---

- 6 Find the component you want the tag to follow the motor tag, for example **CODE:** CAP01, **COMMENTS:** Power factor correction capacitor.
- 7 Edit the API call in the COMMAND\_LIST column for this component. For example, it might look like this:  
(c:ace\_cb\_insym #xyz nil "VCA113\_1-" #scl 8 "%N=@MOTOR\_NUM@")



The last argument of this API call, “%N=@MOTOR\_NUM@”, tells Circuit Builder to use the TAG1 value from the motor, saved as “@MOTOR\_NUM@”, as the number part of the tag for this component. For example, if the component tag format is [defined](#) on page 222 as “%S-%F-%N”, the numeric part of the motor tag is used for the “%N” part of the generated component tag.

You can also define this using a fixed `_TAGFMT` option. Using this approach overrides the component tag format [defined](#) on page 222 for the drawing. Some examples:

- `"_TAGFMT=%F@MOTOR_NUM@"` - used with the component family code string, %F.
  - `"_TAGFMT=%S-@MOTOR_NUM@%F"` - used with the SHEET\_NAME value of the drawing, %S.
  - `"_TAGFMT=CA@MOTOR_NUM@"` - used with a defined text prefix.
- 8 Repeat for each component that should base the tag value off the motor tag value.
  - 9 Save the spreadsheet.

---

**NOTE** It can also be done by defining the MISC1 attribute on the marker blocks for each component as described in [Format the numeric tag of the motor symbol in a wire number](#) on page 2058.

---

## Link a child contact to the parent

As Circuit Builder dynamically builds the circuit, each component receives a component tag. A child contact must link to a parent component to receive the same component tag as the parent.

The parent and child components are automatically linked by Circuit Builder if they each have the same default tag value. For example, the motor starter coil and auxiliary contacts both have a default value “M”.

There can be more than one parent/child relationship within the overall circuit with the same default tag. The overall circuit includes the main circuit template and any branching or nested circuit templates. For example, a reversing motor starter has two starter coils, forward and reverse. Each parent coil must link to the correct child auxiliary contacts and power contacts but they might all have the same default tag value, “M”. To accomplish the correct parent/child links follow these steps.

- 1 Open the circuit template drawings that contain the parent and child marker blocks. There can be more than one circuit template drawing involved, for example a main template with power contacts and a nested template with the starter coils and interlocking auxiliary contacts.
- 2 Find the correct marker block for each component that requires a new default tag link.
- 3 Edit the MISC1 attribute value adding “\_PRETAG={new default tag link}”. For example, add “\_PRETAG=MF” for the forward motor coil and contacts, and “\_PRETAG=MR” for the reverse motor coil and contacts.

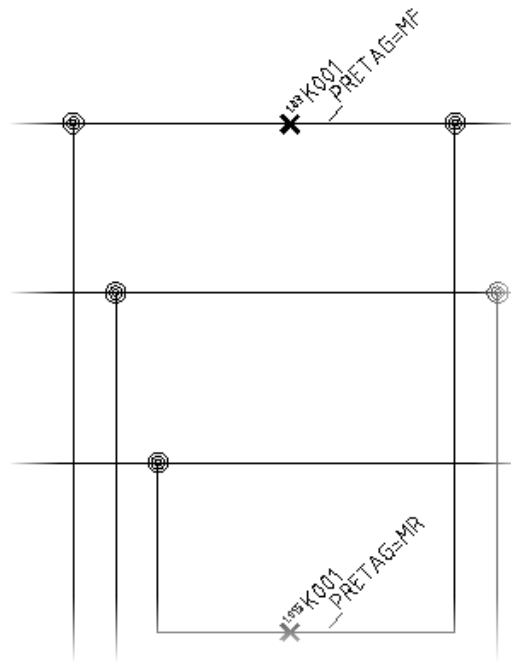



---

**NOTE** The MISC1 attribute value can contain multiple special text flags which direct Circuit Builder to handle the component or underlying wire in a special way. When you add new values, do not overwrite any other special flag values. Separate each one with a semicolon (;).

---

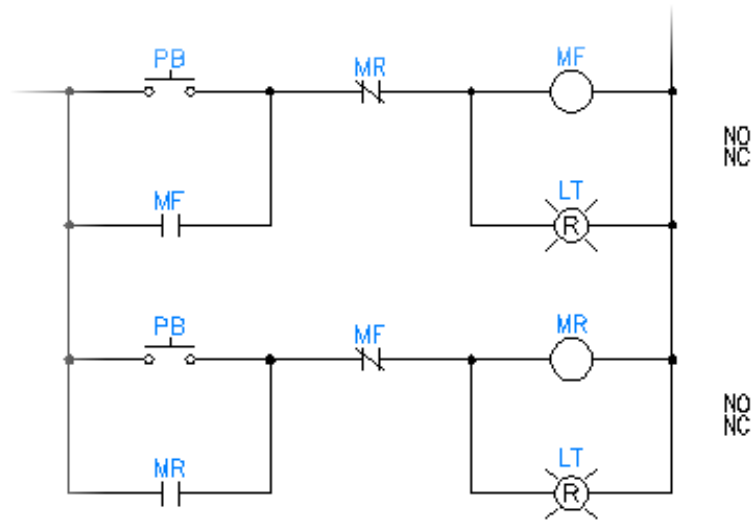
- 4 Save the circuit template drawings.  
When Circuit Builder inserts the nested circuit containing the child contacts, it matches these predefined tag values with the correct parent coil.



### Map motor parameters to the motor symbol attributes

When a motor circuit is selected, a special motor setup/annotation function is called. This special function is flagged by a marker block on the template with a CODE value which maps to a line in the circuit codes sheet marked "MCC\_CTRL" in the UI\_TITLE field. This function references the ace\_electrical\_standards.mdb file to determine full load current and wire size values for a selected set of motor input parameters.

The values generated by this motor setup/annotation function are not automatically written to attributes on the components or wire types on the circuit. These values are saved as an indexed list in an AutoLISP global variable called "#data". Global means that the data is saved in memory and is available while the Circuit Builder continues to construct the circuit. As Circuit Builder processes subsequent marker blocks of the circuit, it can be set up to pull one or more of these saved values from the global and push them out to attributes on the components or used to format appropriate wiretype layer names

This motor setup/annotation must be flagged to happen early on. It is done with an ORDER value which is set to a low number or 0. For example, if the motor full load amps value is used to determine the main disconnect circuit breaker sizing, this data must be in memory before the main disconnecting means marker block is processed.

The elements in the first sublist of the "#data" list are held in memory in the following order. The values related to the motor are held in the first eight elements. See the API documentation for a complete list of elements.

- 0 Motor Type
- 1 Power
- 2 Units
- 3 Voltage
- 4 Phase
- 5 Hertz (Hz)
- 6 Speed (RPM)
- 7 Full Load Amps (FLA)

---

**NOTE** Circuit Builder numbers this indexed list starting at 0 rather than 1.

---

There are two ways to map these values to the attributes on a component.

- On the marker block for the motor, fuse, or circuit breaker symbol in the circuit template drawing.
- In the Circuit Builder spreadsheet circuit codes sheet.

---

**NOTE** The attribute value defined on the marker block overrides any value defined in the spreadsheet.

---

#### **Marker block method**

- 1 Open the circuit template drawing that contains the marker block for the motor, fuse, or circuit breaker symbol.
- 2 Find the correct marker block for the symbol.
- 3 Edit its MISC1 attribute value using the format "{attribute name}=@#@". Replace the "#" with the appropriate index digit to map the correct element. For example, to map the horsepower to the RATING2 attribute, enter "RATING2=HP: @1@". To also map the full load amp value to the RATING4 attribute, enter "RATING2=HP: @1@;RATING4=Full load: @7@ amps". Remember, the indexed list of values is zero based.

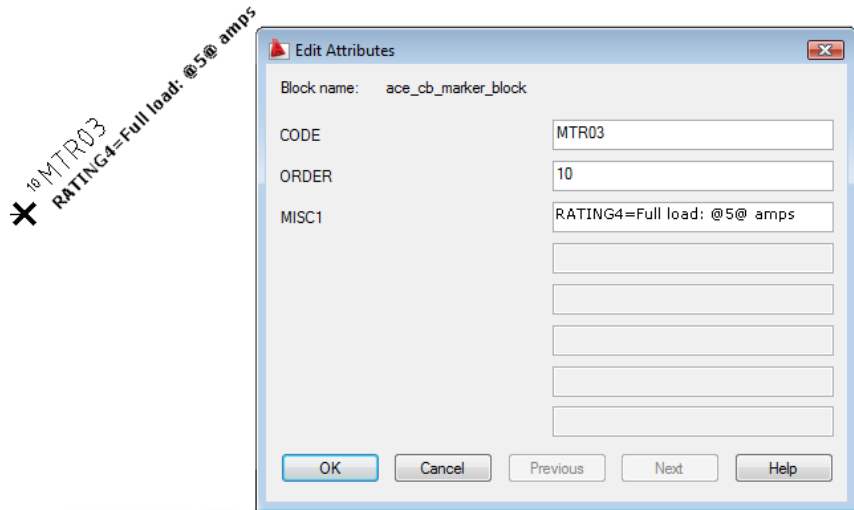

---

**NOTE** The MISC1 attribute value can contain multiple special text flags which direct Circuit Builder to handle the component or underlying wire in a special way. When you add new values, do not overwrite any other special flag values. Separate each one with a semicolon.

---

- 4 Save the circuit template drawing.

### Spreadsheet method

- 1 Open the Circuit Builder spreadsheet, ace\_circuit\_builder.xls.
- 2 Find the circuit CATEGORY and TYPE, for example **CATEGORY:** 3ph Motor Circuit and **TYPE:** Horizontal - FVNR - non reversing.
- 3 Open the circuit code sheet with the same name as the SHEET\_NAME value, for example **SHEET\_NAME:** 3ph\_H.
- 4 Find the motor symbol section, for example **CODE:** MTR03, **COMMENTS:** Motor symbol, **UI\_PROMPT\_LIST:** 3ph motor.

There can be multiple selections within the group. For example, there is a selection for the type of disconnecting means, and a selection to include an auxiliary contact. Each selection is assigned a numerical value from the UI\_VAL field. The values are added to determine the appropriate

action for this combination of selections. The sum is matched to a value in the UI\_SEL field. Once this match is made, the COMMAND\_LIST value, ANNOTATE\_LIST value, and so on, are used to insert and annotate the selections.

- 5 Edit the API call in the COMMAND\_LIST column for this motor symbol. For example, the last argument of this Insert Component API call is used to predefine MISC1 coded values with nil when nothing extra is defined.

Before and after are shown:

**Before:**(c:ace\_cb\_insym #xyz nil "HMO13" #scl 8 nil)

**After:**(c:ace\_cb\_insym #xyz nil "HMO13" #scl 8 "RATING2=HP: @1@")

---

**NOTE** See the API documentation for more information.

---

- 6 Save the spreadsheet.

## Override the default tag format

There are two ways to override the drawing tag format for a component.

- On the marker block for the component in the circuit template drawing.
- In the Circuit Builder spreadsheet circuit codes sheet.

---

**NOTE** The attribute value defined on the marker block overrides any value defined in the spreadsheet.

---

### Marker block method

- 1 Open the circuit template drawing that contains the marker block for the component.
- 2 Find the correct marker block for the component.
- 3 Edit its MISC1 attribute value using the format “\_TAGFMT={format}”, for example, “\_TAGFMT=DISC-%N”.

~~Q001~~  
~~\_TAGFMT=DISC-%N~~

Block name: ace\_cb\_marker\_block

CODE	Q001
ORDER	2
MISC1	_TAGFMT=DISC-%N

OK Cancel Previous Next Help

---

**NOTE** The MISC1 attribute value can contain multiple special text flags which direct Circuit Builder to handle the component or underlying wire in a special way. When you add new values, do not overwrite any other special flag values. Separate each one with a semicolon.

---

- 4 Save the circuit template drawing.

### Spreadsheet method

- 1 Open the Circuit Builder spreadsheet, ace\_circuit\_builder.xls.
- 2 Find the circuit CATEGORY and TYPE, for example **CATEGORY:** 3ph Motor Circuit and **TYPE:** Horizontal - FVNR - non reversing.
- 3 Open the circuit code sheet with the same name as the SHEET\_NAME value, for example **SHEET\_NAME:** 3ph\_H.
- 4 Find the specific component, for example **CODE:** Q001, **COMMENTS:** Disconnecting means, **UI\_PROMPT\_LIST:** Disconnect switch and fuses. There can be multiple selections within the group. For example, there is a selection for the type of disconnecting means, and a selection to include an auxiliary contact. Each selection is assigned a numerical value from the UI\_VAL field. The values are added to determine the appropriate

action for this combination of selections. The sum is matched to a value in the UI\_SEL field. Once this match is made, the COMMAND\_LIST value, ANNOTATE\_LIST value, and so on, are used to insert and annotate the selections.

- 5 Edit the API call in the COMMAND\_LIST column for this component. For example, the last argument of this Insert Multi-pole Component API call is used to predefine MISC1 coded values with nil when nothing extra is defined.

Before and after are shown:

**Before:** (c:ace\_cb\_multipole #xyz nil "HDS11F" 3 #scl 4 nil)

**After:** (c:ace\_cb\_multipole #xyz nil "HDS11F" 3 #scl 4  
" \_TAGFMT=DISC-%N")

---

**NOTE** See the API documentation for more information.

---

- 6 Save the spreadsheet.

## Override the default wire number format

There are two ways to override the drawing wire number format for a wire number.

- On the marker block positioned over the wire in the circuit template drawing.
- In the Circuit Builder spreadsheet circuit codes sheet.

---

**NOTE** The attribute value defined on the marker block overrides any value defined in the spreadsheet.

---

### Marker block method

- 1 Open the circuit template drawing that contains the marker block for the wire number.
- 2 Find the correct marker block for the wire number.
- 3 Edit its MISC1 attribute value using the format “\_TAGFMT={format}”, for example, “\_TAGFMT=%N-T1”.



✗ 11.1 WN01F  
\_TAGFMT=%N-T1

Block name: ace\_cb\_marker\_block

CODE	WN01F
ORDER	11.1
MISC1	_TAGFMT=%N-T1

OK Cancel Previous Next Help

---

**NOTE** The MISC1 attribute value can contain multiple special text flags which direct Circuit Builder to handle the component or underlying wire in a special way. When you add new values, do not overwrite any other special flag values. Separate each one with a semicolon.

---

- 4 Save the circuit template drawing.

### Spreadsheet method

- 1 Open the Circuit Builder spreadsheet, ace\_circuit\_builder.xls.
- 2 Find the circuit CATEGORY and TYPE, for example **CATEGORY:** 3ph Motor Circuit and **TYPE:** Horizontal - FVNR - non reversing.
- 3 Open the circuit code sheet with the same name as the SHEET\_NAME value, for example **SHEET\_NAME:** 3ph\_H.
- 4 Find the specific wire number, for example **CODE:** WN01F, and **COMMENTS:** Insert wire number on network, use drawing defaults, mark it as "fixed".
- 5 Edit the API call in the COMMAND\_LIST column for this component. For example, the last argument of this Insert Wire Number API call is used to predefine MISC1 coded values with nil when nothing extra is defined.

Before and after are shown:

**Before:** (c:ace\_cb\_wnum nil nil 1 nil)

**After:**(c:ace\_cb\_wnum nil nil 1 “\_TAGFMT=%N-T1”)

---

**NOTE** See the API documentation for more information.

---

- 6 Save the spreadsheet.

## Predefine attribute values

There are three ways to predefine attribute values for a component.

- On the marker block for the component in the circuit template drawing.
- In the Circuit Builder spreadsheet circuit codes sheet.
- [Annotation presets](#) on page 2072 - provides the ability to select which attribute values to apply when the circuit is inserted.

---

**NOTE** An annotation preset value overrides the attribute value defined on the marker block. The attribute value defined on the marker block overrides any value defined in the spreadsheet.

---

## Marker block method

- 1 Open the circuit template drawing that contains the marker block for the component.
- 2 Find the correct marker block for the component.
- 3 Edit its MISC1 attribute value using the format “{attribute name}={attribute value}”, for example, “DESC1=MOTOR”.

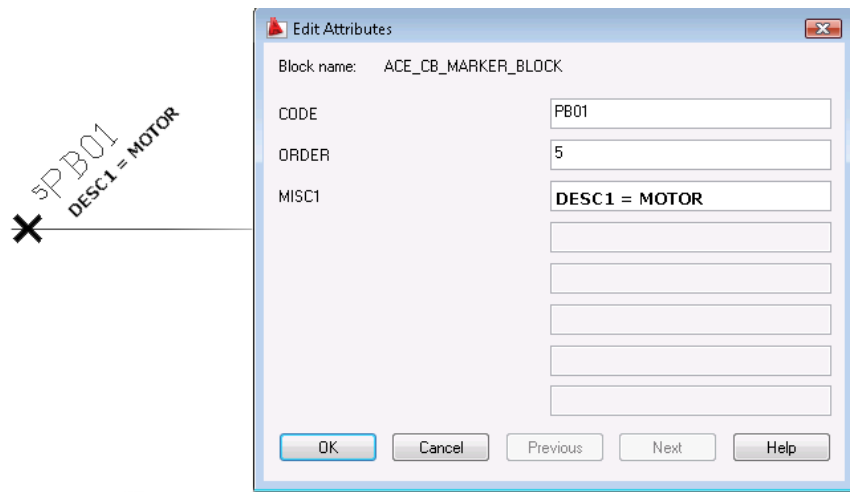

---

**NOTE** The MISC1 attribute value can contain multiple special text flags which direct Circuit Builder to handle the component or underlying wire in a special way. When you add new values, do not overwrite any other special flag values. Separate each one with a semicolon.

---

- 4 Save the circuit template drawing.

### Spreadsheet method

- 1 Open the Circuit Builder spreadsheet, ace\_circuit\_builder.xls.
- 2 Find the circuit CATEGORY and TYPE, for example **CATEGORY:** 3ph Motor Circuit and **TYPE:** Horizontal - FVNR - non reversing.
- 3 Open the circuit code sheet with the same name as the SHEET\_NAME value, for example **SHEET\_NAME:** 3ph\_H.
- 4 Find the specific component, for example **CODE:** PB01, **COMMENTS:** STOP, **UI\_PROMPT\_LIST:** Push button - Standard.

There can be multiple selections within the group. For example, there is a selection for the type of disconnecting means, and a selection to include an auxiliary contact. Each selection is assigned a numerical value from the UI\_VAL field. The values are added to determine the appropriate action for this combination of selections. The sum is matched to a value in the UI\_SEL field. Once this match is made, the COMMAND\_LIST value, ANNOTATE\_LIST value, and so on, are used to insert and annotate the selections.

- 5 Edit the API call in the COMMAND\_LIST column for this component. For example, the last argument of this Insert Component API call is used to predefine MISC1 coded values with nil when nothing extra is defined.

Before and after are shown:

**Before:** (c:ace\_cb\_insym #xyz nil "HPB12" #scl 8 nil)

**After:** (c:ace\_cb\_insym #xyz nil "HPB12" #scl 8  
"DESC1=CONVEYOR;DESC2=SYSTEM RESET")

---

**NOTE** See the API documentation for more information.

---

- 6 Save the spreadsheet.

### See also:

- [Predefine attribute values using annotation presets](#) on page 2072

### Predefine attribute values using annotation presets

Annotation presets allow you to:

- Predefine description text, installation, location values for individual components in the circuit.
- Select which attribute values to apply to the circuit when it is built.
- Edit the attribute values before the circuit is built.

- 1 Open the Circuit Builder spreadsheet, ace\_circuit\_builder.xls.
- 2 Open the ACE\_CIRCS sheet.
- 3 Find the circuit CATEGORY and TYPE, for example **CATEGORY:** 3ph Motor Circuit and **TYPE:** Horizontal - FVNR - non reversing.
- 4 Assign a code value in the ANNO\_CODE field if there isn't one, for example **ANNO\_3M**.
- 5 In AutoCAD Electrical, open the circuit template drawing listed in the DWG\_TEMPLATE field, for example ace\_cb1\_FVNR\_H.dwg.
- 6 Open the ANNO\_CODE sheet in the spreadsheet.  
This sheet provides a link between the circuit you select (identified by the ANNO\_CODE value), a specific marker block (identified by its CODE value), and a specific attribute on the marker block.

7 Enter the ANNO\_CODE value from earlier in the ANNO\_CODE field of a blank row, **ANNO\_3M**.

For this example, you define some attribute values for the motor symbol.

8 In AutoCAD Electrical, find the marker block that defines the insertion point for the motor symbol. Find the CODE attribute value, for example **MTR03**.

9 In the spreadsheet, add a new line in the ANNO\_CODE table for each attribute you wish to predefine. For example:

- ANNO\_CODE = **ANNO\_3M**. It is the value from the ACE\_CIRCS sheet for this circuit.

- CODE = **MTR03**. It is the value from the CODE attribute on the marker block.

- ATTRIBUTE = **LOC**. It is the attribute name you want to predefine.

- PROMPT = **Motor - Location code**. This is the text used on the [Annotation Presets](#) on page 708 dialog box. This dialog box is displayed if you select the Presets - List button when the circuit is inserted.

- Default = **FIELD**. It is the attribute value to apply to the LOC attribute when the motor symbol is inserted.

10 Repeat for each attribute value you want to predefine. The ANNO\_CODE and CODE values should be the same for each attribute on this motor symbol.

11 Save and close the spreadsheet.

You are now ready to test the changes.

12 Click Schematic tab ► Insert Components panel ► Circuit Builder



drop-down ► Circuit Builder.

13 Select the circuit CATEGORY and TYPE, **CATEGORY:** 3ph Motor Circuit and **TYPE:** Horizontal - FVNR - non reversing.

14 Select the Presets button in the Special Annotation section.

15 Select the Lists button next to Presets.

The Annotation Presets dialog box displays. Any attributes with non-blank values are selected by default and applied to the symbol when it is

inserted. You can select which attribute values to apply or edit the values as necessary.

16 Select OK.

17 On the Circuit Selection dialog box, select Insert.  
The circuit is built and the attribute values are applied.

**Annotation Presets**

1	A	B	C	D	E
1	CATEGORY	TYPE	DWG_TEMPLATE	SHEET_NAME	ANNO_CODE
2	3ph Motor Circuit	Horizontal - FVNR - non reversing	ace_cb1_FVNR_H.dwg	3ph_H	ANNO_3M
3		Horizontal - FVR - reversing	ace_cb1_FVR_H.dwg	3ph_H	ANNO_3M
4		Vertical - FVNR - non reversing	ace_cb1_FVNR_V.dwg	3ph_V	ANNO_3M
5		Vertical - FVR - reversing	ace_cb1_FVR_V.dwg	3ph_V	ANNO_3M
6	3ph Power Feed	Horizontal - Single feed	ace_cb1_Feed_H.dwg	3ph_H	ANNO_3F
7		Vertical - Single feed	ace_cb1_Feed_V.dwg	3ph_V	ANNO_3F
8	1ph Motor Circuit	Horizontal	ace_cb1_FV1_H.dwg	1ph_H	ANNO_3M
9		Vertical	ace_cb1_FV1_V.dwg	1ph_V	ANNO_3M
10	1ph Power Feed	Horizontal	ace_cb1_Feed1_H.dwg	1ph_H	ANNO_3F
11		Vertical	ace_cb1_Feed1_V.dwg	1ph_V	ANNO_3F
12	One-line Motor Circuit	Horizontal - FVNR - non reversing	ace_cb1_FVNR_H_1-.dwg	1_LINE_H	ANNO_1M
13		Horizontal - FVR - reversing	ace_cb1_FVR_H_1-.dwg	1_LINE_H	ANNO_1M
14		Horizontal - Dual FVNR - non reversing	ace_cb1_FVNR_2H_1-.dwg	1_LINE_H	ANNO_1M
15		Vertical - FVNR - non reversing	ace_cb1_FVNR_V_1-.dwg	1_LINE_V	ANNO_1M
16		Vertical - FVR - reversing	ace_cb1_FVR_V_1-.dwg	1_LINE_V	ANNO_1M

1	A	B	C	D	E	F
1	ANNO_CODE	CODE	ATTRIBUTE	PROMPT	DEFAULT	
2	ANNO_1M		TAG1	Bus-tap symbol Tag-ID		
3	ANNO_1M		INST	Bus-tap symbol INST		
4	ANNO_1M		LOC	Bus-tap symbol LOC		
5	ANNO_1M	MTR03	TAG1	Motor Tag ID		
6	ANNO_1M	MTR03	INST	Motor - Installation code		
7	ANNO_1M	MTR03	LOC	Motor - Location code		
8	ANNO_1M	MTR03	DESC1	Motor - Description Line 1		
9	ANNO_1M	MTR03	DESC2	Motor - Description Line 2		
10	ANNO_1M	MTR03	DESC3	Motor - Description Line 3		
11	ANNO_3M	MTR03	TAG1	Motor Tag ID		
12	ANNO_3M	MTR03	INST	Motor - Installation code		
13	ANNO_3M	MTR03	LOC	Motor - Location code		
14	ANNO_3M	MTR03	DESC1	Motor - Description Line 1		
15	ANNO_3M	MTR03	DESC2	Motor - Description Line 2		
16	ANNO_3M	MTR03	DESC3	Motor - Description Line 3		
17	ANNO_3M	PR01	DESC1	Start PB - Description Line 1	Start	
18	ANNO_3M	PB02	DESC1	Stop PB - Description Line 1	Stop	
19	ANNO_3F	IRI K01	TAG1	Load Tag ID		

Find the ANNO\_CODE value from ACE\_CIRCS table in the ANNO\_CODE table.

Assign the attribute values to the block inserted at the marker block with the matching CODE value.

## Predefine a wire number

Predefine a wire number on the wire number marker block on the circuit template drawing.

- 1 Open the circuit template drawing that contains the marker block for the wire number.
- 2 Find the correct marker block for the wire number.
- 3 Edit its MISC1 attribute value using the format “\_TAGFMT={wire number}”, for example, “\_TAGFMT=24COM”.

~~11.1 WN01F  
\_TAGFMT=24COM~~

Block name: ace\_cb\_marker\_block

CODE: WN01F

ORDER: 11.1

MISC1: \_TAGFMT=24COM

Buttons: OK, Cancel, Previous, Next, Help

---

**NOTE** The MISC1 attribute value can contain multiple special text flags which direct Circuit Builder to handle the component or underlying wire in a special way. When you add new values, do not overwrite any other special flag values. Separate each one with a semicolon.

---

4 Save the circuit template drawing.

---

**NOTE** To get a fixed wire number, you must adjust the API call in the spreadsheet to indicate it. See the API documentation for more information.

---

### Set circuit element defaults

The first sheet of the Circuit Builder spreadsheet, ACE\_CIRCS, defines circuit categories, types, main templates, and associated circuit code sheet names. These circuit code sheets include a default option for each circuit element.

For example, the circuit template has a marker block that references a main disconnecting means in the circuit code sheet for the template. The circuit code sheet lists four options:

- Circuit Breaker
- Fuses
- Fused Disconnect
- Disconnect Switch (non-fused)

When the Circuit Configuration dialog box opens, and you select Main Disconnecting Means from the Circuit Elements tree structure, the Fused Disconnect option is selected. If you select Insert, instead of Configure, to insert the circuit without user prompts, the Fused Disconnect is used for the main disconnecting means.

If you always want a different option selected or used as the default, this value can be changed.

- 1 Open the Circuit Builder spreadsheet, ace\_circuit\_builder.xls.
- 2 Find the circuit category and type in the ACE\_CIRCS sheet, for example **Category:** 3ph Motor Circuit and **Type:** Horizontal - FVNR - non reversing.
- 3 Find the value in the SHEET\_NAME column, for example 3ph\_H. Open the worksheet by selecting on the 3ph\_H tab.
- 4 Find the circuit element by looking at the values in the COMMENTS and UI\_TITLE columns. For example, **COMMENTS:** Disconnecting Means and **UI\_TITLE:** Main Disconnect.  
Notice there are multiple options for this circuit element as listed in the UI\_PROMPT\_LIST column. The current default option is indicated by an "X" in the UI\_DEF column.
- 5 Move the "X" in the UI\_DEF column to the row containing the option you want as the default, for example Circuit Breaker. Make sure that only one row for the group contains an "X".
- 6 Save the spreadsheet.

## Set up component auto-sizing

Circuit Builder can calculate the rating for components in the circuit based upon some multiple of the full load amp value of the motor or load. For example, the electrical code standard might state that a disconnect switch must be rated not less than 115% of the load amperage. An expected maximum load of 28 amps would require a disconnect switch rated at not less than 115% of 28 amps, or 32.2 amps. If standard switch ratings are 30 and 60 amps, a 60 amp switch would be selected.

Such an automatic calculation can be accomplished by creating a relationship between the call in the ANNOTATE\_LIST field value in the [circuit codes sheet](#) on page 2006 of the circuit builder spreadsheet, and the MOTOR\_I\_\* tables in the [electrical standards database](#) on page 2015.



Here is how it is defined:

- The CODE value of the marker block on the inserted circuit template drawing, points at a group of rows in the circuit codes sheet. These rows define the types of components that can be inserted at the location of this marker block.
- The row for the inserted component, either the default component or the component selected on the Circuit Configuration dialog box, contains an ANNOTATION\_LIST column value.
- The ANNOTATE\_LIST column value contains a call to the API function c:ace\_cb\_anno2. This function includes a code argument like "A1".
- The code argument should match a code value in the MOTOR\_I\_DESC table of the electrical standards database file.

MOTOR_I_DESC_NEC	
CODE	Description
A1	Disconnect switch - non-fused
A2	Fuses
A3	Fuses (time-delay)
A4	Circuit Breaker (magnetic/instantaneous)
A5	Circuit Breaker (thermal/inverse time)
A7	Disconnect switch and fuses
A8	Disconnect switch and fuses (time-delay)

Here is an example for a disconnect switch entry:

(c:ace\_cb\_anno2 nil "A1" "RATING1" 0 nil)

In this example, "A1" is the code to match in the MOTOR\_I\_DESC table (for "Disconnect switch non-fused"), and "RATING1" is the attribute on the inserted disconnect switch symbol to receive the final calculated amp value.

- The MOTOR\_I\_CALC table also has a column of data with a label that matches the code used in the C:ace\_cb\_anno2 call.

MOTOR_I_CALC_NEC	
Type	A1
Induction	(I * 1.15)
Induction - Design B	(I * 1.15)
Induction - Wound rotor	(I * 1.15)
Synchronous	(I * 1.15)
Single-phase	(I * 1.15)

- The cell in the MOTOR\_I\_CALC table contains an expression using “I” to represent the full load amps of the motor. This expression is evaluated using the actual full load amps for the motor. The calculated value is used to determine the value to assign to the attribute.

Valid operations are +\*/^ . The “^” character is the exponential function. For example, I^2 is I squared, while I^0.5 is the square root of I.

If-then-else statements are supported including one level of nested statements. For example, “(if (I > 400) then (I \* 8) else (I \* 11))” means the calculated amp value is eight times FLA current for 0-400 amps and 11 times for greater than FLA of 400 amps. One level of nesting is supported. “(if (I >= 9.0) then (I \* 1.25) else if (I < 2.0) then (I \* 3.0) else (I \* 1.67))” means the calculated value is set to (I \* 1.67) if I is less than 9 but greater or equal to 2.0 amps. If less than 2.0 amps it is (I \* 3.0) and if greater than or equal to 9.0 amps it is (I \* 1.25).

Valid Boolean operations are >, <, >=, <=, =.

- The MOTOR\_I\_MAP table contains a row with a matching code value, such as “A1”.

MOTOR_I_MAP_NEC		
CODE	MAX	RATING
A1	30	30A
A1	60	60A
A1	100	100A
A1	150	150A
A1	200	200A
A1	250	250A
A1	400	400A
A1	600	600A
A1	800	800A
A1	1200	1200A

- The result of the calculation, made from the expression in the MOTOR\_I\_CALC table, is compared to the MAX values in the MOTOR\_I\_MAP table to determine the appropriate RATING value. In the earlier example, the 28 amp motor load multiplied by 1.15 yields 32.2 amps minimum for “A1”. This means that a match is made on the record with a MAX value of 60 and yields a 60A switch rating.
- The RATING value is assigned to the attribute specified in the c:ace\_cb\_anno2 call, for example “RATING1”.
- Define an optional catalog assignment to the component by adding a value in the DEFAULT field in the MOTOR\_I\_MAP table. The format is

MFG={manufacturer};CAT={catalog}. For example, an “A3” entry for 15A time-delay fuses might look like the following example:  
MFG=BUSSMAN;CAT=KTK-R-15

When a component has multiple calculated values such as a disconnect switch with fuses, the two RATING attributes for the component are semicolon delimited, as shown in this example:

(c:ace\_cb\_anno2 nil “A7” “RATING1;RATING2” nil 0)

The MOTOR\_I\_MAP table contains corresponding semicolon delimited values in the RATING column.

MOTOR_I_MAP_NEC		
CODE	MAX	RATING
A7	45	60A;45A
A7	50	60A;50A
A7	60	60A;60A
A7	70	100A;70A
A7	75	100A;75A
A7	80	100A;80A
A7	85	100A;85A
A7	90	100A;90A

---

**NOTE** See the API documentation for more information on the Circuit Builder API calls.

---

## Stretch and connect wiring from a nested template

A marker block is placed at or near the end of a wire on the circuit template that indicates to Circuit Builder that the wire should try and connect to a nearby wire. The marker block should be placed at or near the end of the wire that must stretch.

There are two options that can be used in the MISC1 attribute value.

**\_WIRESKIP=n**

“n” is the number of wires to skip over before connection is attempted. If the \_WIRESKIP flag is missing or set to 0, Circuit Builder stretches and connects to the first wire it encounters. If the value is 1, it skips over one wire before trying to make a connection.

**\_MAXTRAPCOUNT=n**

“n” is the number of trap distance units to search for a wire connection. To see the trap distance value for a drawing, look on the Drawing Properties dialog box, Drawing format tab. The

trap distance cannot be set. It is calculated from the drawing scale.

---

**NOTE** If this value is not defined on the marker block, Circuit Builder uses a distance value equal to 200 times the trap distance value of the drawing.

---

The CODE value of the marker block must tie in to the (c:ace\_cb\_stretch\_wire\_connect #xyz nil #misc1) API call in the spreadsheet. The values on the MISC1 attributes are used for the #misc1 argument.

**X** 1.02 WCON  
\_WIRESKIP=2; \_MAXTRAPCOUNT=400

---

**X** 1.02 WCON  
\_WIRESKIP=1; \_MAXTRAPCOUNT=400

---

**X** 1.02 WCON  
\_MAXTRAPCOUNT=400

---

---

**NOTE** If the marked wire has a terminal at its end, Circuit Builder stretches the wire and moves the terminal. It stretches based on the origin of the connected terminal rather than the end of the wire.

---

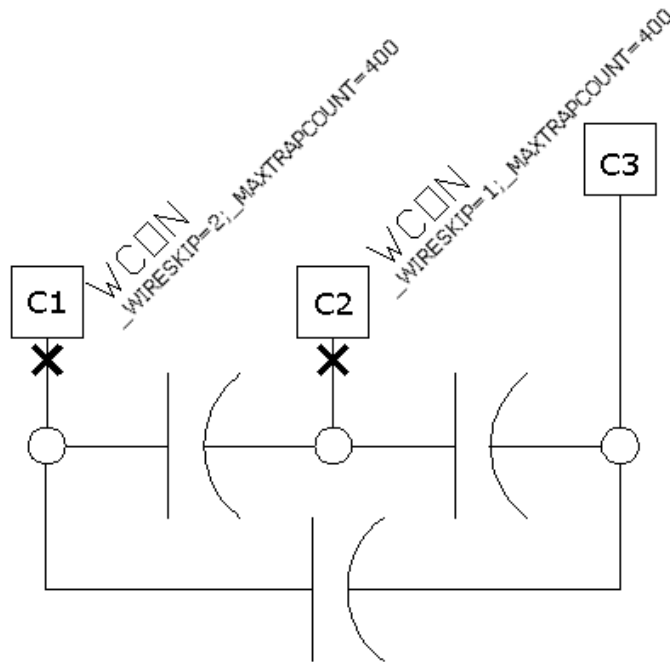

## Build your own symbols

### Build your own symbols

You can use the Symbol Builder to create an AutoCAD Electrical symbol or to convert existing non-AutoCAD Electrical symbols. This utility builds an AutoCAD Electrical symbol by either adding AutoCAD Electrical attributes to

the geometry of the symbol or by converting text entities to AutoCAD Electrical attributes.

You can also use AutoCAD attribute definition and editing commands to do the same thing. Use this tool to quickly pick and place attributes. It tracks what attributes are present and checks your work to make sure that any AutoCAD Electrical required attributes are not omitted. For this exercise, you create a symbol and add AutoCAD Electrical attributes to the new geometry.

Symbol Builder works in the Block Editor environment. You can add or modify the geometry of the symbol using standard AutoCAD commands within this environment.

## Create a parent schematic symbol

In this exercise, you create a power supply using the Symbol Builder tool.

---

**NOTE** If you exit out of the Symbol Builder, restart it, and on the Select Symbol/Objects dialog box, click Select objects and select any graphics and attributes you added so far. You can then resume from where you left off.

---

- 1 In an AutoCAD drawing, draw a rectangle on the drawing.

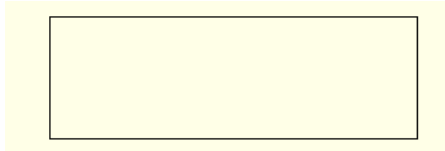

---

**NOTE** You can also create and modify the graphics for the symbol in the Block Editor environment.

---

- 2 Click Schematic tab ► Other Tools panel ► Symbol Builder drop-down



► Symbol Builder.

- 3 In the Select Symbol/Objects dialog box, Attribute template section, browse to the Library path

**Windows XP:** C:\Documents and Settings\All Users\Documents\Autodesk\Acade {version}\jic125

**Windows Vista, Windows 7:** C:\Users\Public\Documents\Autodesk\Acade {version}\jic125

- 4 In the Attribute template section, choose Symbol: Horizontal Parent.

- 5 In the Attribute template section, choose Type: Generic.
- 6 In the Select from drawing section, click Select objects and select the rectangle.
- 7 Select OK.

### Add attributes

In this part of the exercise, you insert some AutoCAD Electrical attributes from the Symbol Builder Attribute Editor. You are not limited to these attributes, and you can include your own user-defined attributes on the AutoCAD Electrical block files.

---

**NOTE** The TAG1 attribute is the only one required for a parent schematic symbol. The other attributes in the Required section are expected on a parent schematic symbol, however the symbol is recognized as a parent symbol without them.

---

- 1 If the Symbol Builder Attribute Editor is not visible, Click Symbol Builder tab ► Edit panel ► Palette Visibility Toggle.



- 2 Select the TAG1 attribute.



- 3 Select the Properties tool to launch the Insert/Edit Attributes dialog box.

- 4 Change the height to 0.125 and Justify to Center.

- 5 Enter "PS" as the Value. It is the default code used as the %F value of the tag format (such as "CR", "PB", "LT")

- 6 Select OK.



- 7 Click the Insert Attribute tool.

- 8 Select an insertion point for the attribute.

---

**NOTE** You can also right-click and select Insert Attribute or drag the attribute to insert it.

---



- 9  Select DESC1, click the Insert Attribute tool, and insert it below TAG1.

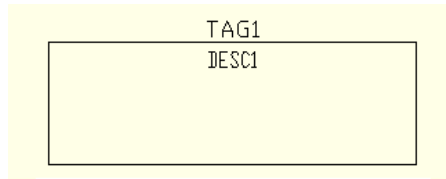

- 10 Repeat to insert the INST and LOC attributes above TAG1.
- 11 Select MFG, CAT, and ASSYCODE. Click the Insert Attribute tool, and insert them near the center of the rectangle.

---

**NOTE** If the CAT and ASSYCODE attributes are not listed they are inserted with MFG as a group.

---

- 12 Repeat to insert the FAMILY attribute near the center of the rectangle.

- 13  With FAMILY still highlighted in the Symbol Builder Attribute Editor, select the Properties tool. Enter “PS” as the Value and OK. This assigns the %F value to the FAMILY attribute inserted.

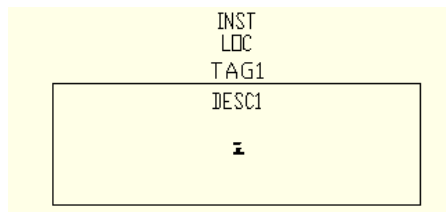

### Add wire connection attributes

You can define wire connection points and terminal text for the library symbol. When you add a wire connection, you select the style, the direction the wire connects from, and whether to include the optional TERMxx and TERMDISCxx attributes. In this exercise, wire connection attributes are inserted at the left, bottom, and right side of the symbol.

- 1 If the Symbol Builder Attribute Editor is not visible,

Click Symbol Builder tab ► Edit panel ► Palette Visibility Toggle.



- 2 Expand the Wire Connection section of the Symbol Builder Attribute Editor.
- 3 Expand the Direction/Style list and select Others to launch the Insert Wire Connections dialog box.

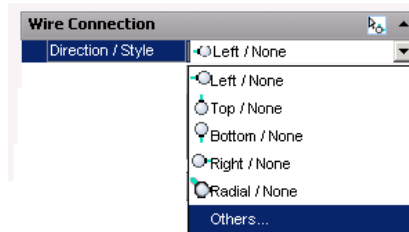

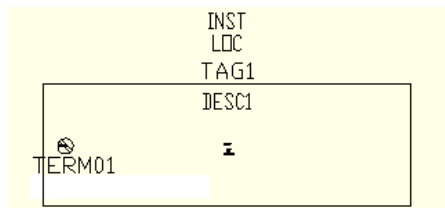

- 4 On the Insert Wire Connections dialog box, select Terminal Style: Screw.
- 5 Select Connection Direction: Left.
- 6 Check Use this configuration as default. This directs Symbol Builder to use the current Terminal Style and Scale as the default in the drop-down list.
- 7 (Optional) Enter "L1" as the TERM01 value. This sets "L1" as the default terminal pin number when the symbol is used.
- 8 (Optional) Select TERMDISC01 in the Pin Information section and click Delete. This directs Symbol Builder not to insert the optional TERMDISCxx attribute with the wire connection attribute.
- 9 Click Insert and select in the center of the left-hand side of the rectangle as shown. The wire connection attribute, X4TERM01, and the terminal pin attribute, TERM01, are inserted.

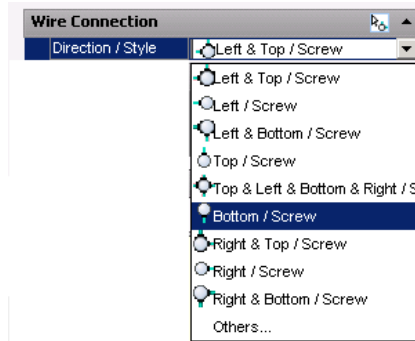

- Back on the Symbol Builder Attribute Editor, expand the Wire Connection list and select Bottom/Screw.



-  Select the Insert Wire Connection tool and insert the terminal in the bottom center of the rectangle.
- Select Right/Screw from the Wire Connection Direction/Style list.
-  Select the Insert Wire Connection tool and insert the terminal in the center of the right-hand side of the rectangle.

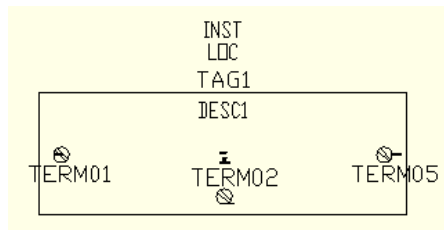

- In the Pins section, enter "GND" in the TERM02 value, and "L2" in the TERM03 value.

Pins	
Left	
TERM01	L1
Bottom	
TERM02	GND
Right	
TERM05	L2

## Finishing the parent symbol



- 1 Click Symbol Builder tab ► Edit panel ► Done.
- 2 Click Base Point: Pick point and select the center of the rectangle.
- 3 Select Wblock. Wblock creates the symbol .dwg file, while Block creates the symbol for this drawing file only.
- 4 Enter the Name and file path or keep the default. AutoCAD Electrical provides a default name for the new symbol based on the attribute template selected. Avoid changing the first four letters of the file name and limit the total length to 32 characters.
- 5 (Optional) If you are going to add the symbol to the icon menu at a later time using the [Icon Menu Wizard](#) on page 1231, check Icon image. Enter the image name and folder.
- 6 (Optional) Click Details to see the [Symbol Audit](#) on page 359 dialog box listing potential issues with your symbol.
- 7 Select OK.
- 8 Select Close Block Editor from the block editor toolbar.
- 9 (Optional) Select Yes to insert the symbol on the drawing and select a location. If you place the component on an existing wire, the wire breaks. The component tag is assigned.

## Additional options

The additional options for creating a symbol listed are not used for this example, but you can use them when creating your own symbol.

- **Optional Attributes:** The attributes listed in this section are allowed on a parent symbol. You can also add attributes to the Required or Optional list using the following steps.



- 1 Select the Add Attribute tool to launch the Insert/Edit Attributes dialog box.
- 2 Enter the attribute name as the Tag value.
- 3 Enter all property values.

- 4 Click Insert to insert the attribute or OK to add it to the list without inserting it.

- **Link Lines:** Inserts Link Line attributes so the program can draw dashed link lines between a parent symbol and its related child contact. It requires special attributes at the point where the dashed line connects to the symbol.

- 1 Expand the Link Lines section.
- 2 Select a direction from the Direction list.



- 3 Select the Insert Link Lines tool.
- 4 Select a location for the Link Line attribute.

- **RATING or POS sections:** You can add up to 12 Rating and Position attributes. If the attribute template contains a RATING1 or POS1 attribute, or you add one, these sections are available on the Symbol Builder Attribute Editor.

- 1 Expand the RATING or POS section.



- 2 Select the Add Next tool.
- 3 Pick an insertion point.

- **Convert Text to Attribute dialog box:** If you selected existing text entities from the Select Symbol/Objects dialog box, or added text while in the Block Editor environment, this option converts existing text entities to AutoCAD Electrical attributes in the same location as the original text.



- 1 Select the Convert Text to Attribute tool from the Symbol Builder toolbar to launch the dialog box.
- 2 Select a text entry in the list and click the arrow pointing at the attribute name.
- 3 Repeat for all text entities.
- 4 Click Done. The text entity is converted to the attribute. The text value becomes the default value for the attribute.

- **Convert text:** If you selected existing text entities from the Select Symbol/Objects dialog box, or added text while in the Block Editor environment, this option converts a single text entity to an AutoCAD Electrical attribute in the same location as the original text.

- 1 Select an attribute on the Symbol Builder Attribute Editor.



- 2 Select the Convert Text tool.

- 3 Select the text entity. The text entity is converted to the attribute. The text value becomes the default value for the attribute.

- **Audit Symbol:** At any time you can [audit](#) on page 359 the symbol to find any potential issues with your symbol and symbol name.

## Create a schematic terminal symbol

In this exercise, you create a schematic terminal using the Symbol Builder tool.

---

**NOTE** If you exit out of the Symbol Builder, restart it, and on the Select Symbol/Objects dialog box, click Select objects and select any graphics and attributes you added so far. You can then resume from where you left off.

---

- 1 In an AutoCAD drawing, draw a rectangle on the drawing.

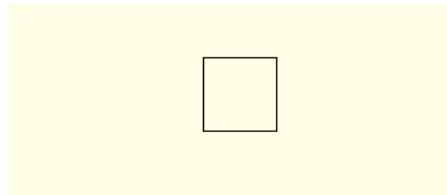

---

**NOTE** You can also create and modify the graphics for the symbol in the Block Editor environment.

---

- 2 Click Schematic tab ➤ Other Tools panel ➤ Symbol Builder drop-down



- Symbol Builder.

- 3 In the Select Symbol/Objects dialog box, Attribute template section, browse to the Library path

**Windows XP:** C:\Documents and Settings\All Users\Documents\Autodesk\Acade {version}\jic125

**Windows Vista, Windows 7:** C:\Users\Public\Documents\Autodesk\Acade {version}\jic125

- 4 In the Attribute template section, choose Symbol: Horizontal Terminal.
- 5 In the Attribute template section, choose Type: Terminal with wire number.
- 6 In the Select from drawing section:, click Select objects and select the rectangle.
- 7 Select OK.

### Add attributes

In this part of the exercise, you insert some AutoCAD Electrical attributes from the Symbol Builder Attribute Editor. You are not limited to these attributes, and you can include your own user-defined attributes on the AutoCAD Electrical block files.

---

**NOTE** The TAGSTRIP attribute is the only one required for a schematic terminal. The other attributes in the Required section are expected on a schematic terminal, however the symbol is recognized as a schematic terminal without them.

---

- 1 If the Symbol Builder Attribute Editor is not visible, Click Symbol Builder tab ➤ Edit panel ➤ Palette Visibility Toggle.



- 2 Select the TAGSTRIP attribute.



- 3 Select the Properties tool to launch the Insert/Edit Attributes dialog box.

- 4 Change the height to 0.125 and Justify to Center.

- 5 Select OK.



- 6 Click the Insert Attribute tool.

7 Insert the attribute above the rectangle.

8  Select WIRENO, click the Insert Attribute tool, and insert it above TAGSTRIP. Use the Properties tool to change it to Justify = Center.



9 Select MFG, CAT, and ASSYCODE. Click the Insert Attribute tool, and insert them near the center of the rectangle.

---

**NOTE** If the CAT and ASSYCODE attributes are not listed they are inserted with MFG as a group.

---

### Add wire connection attributes

You can define wire connection points for the library symbol. When you add a wire connection, you select the style and the direction the wire connects from. In this exercise, wire connection attributes are inserted at the left, right, top, and bottom of the terminal so that it can be inserted in either horizontal or vertical wires.

1 If the Symbol Builder Attribute Editor is not visible,  
Click Symbol Builder tab ► Edit panel ► Palette Visibility Toggle.



2 Expand the Wire Connection section of the Symbol Builder Attribute Editor.

3 Select Left/None.

---

**NOTE** If the default terminal style is not None, select Others and change the default style to None. This wire connection style contains attributes only.

---



- 4  Select the Insert Wire Connection tool and insert the wire connection in the center of the left-hand side of the rectangle. Use the Midpoint OSnap to insert the wire connection attribute in the middle of the line.
- 5 The wire connection insertion remains active until you press Enter. Press “R{spacebar}” and insert the wire connection attribute in the center of the right-hand side of the rectangle.
- 6 Press “T{spacebar}” and insert the wire connection in the center of the top of the rectangle.
- 7 Press “B{spacebar}” and insert the wire connection in the center of the bottom of the rectangle. Press Enter.



### Finishing the terminal symbol

- 1 Click Symbol Builder tab ► Edit panel ► Done. 
- 2 Click Base Point: Pick point and select the center of the rectangle.
- 3 Select Wblock. Wblock creates the symbol .dwg file, while Block creates the symbol for this drawing file only.
- 4 Enter the Name and file path or keep the default. AutoCAD Electrical provides a default name for the new symbol based on the attribute template selected. Avoid changing the first four letters of the file name and limit the total length to 32 characters.

One-line symbols follow the same naming convention as schematic parent and child symbols. For convenience the one-line symbols provided have a “1-” suffix. However, the symbol name does not define the symbol

as a one-line symbol. This is defined by the [WDTYPE attribute](#) on page 325 value of "1-" on the symbol, or a "1-1" on a one-line bus-tap symbol.

- 5 (Optional) If you are going to add the symbol to the icon menu at a later time using the [Icon Menu Wizard](#) on page 1231, check Icon image. Enter the image name and folder.
- 6 (Optional) Click Details to see the [Symbol Audit](#) on page 359 dialog box listing potential issues with your symbol.
- 7 Select OK.
- 8 Select Close Block Editor from the block editor toolbar.
- 9 (Optional) Select Yes to insert the symbol on the drawing and select a location. If you place the terminal on an existing wire, the wire breaks. The terminal tag is assigned.

## Create a one-line parent symbol

In this exercise, you create a one-line circuit breaker parent using the Symbol Builder tool.

---

**NOTE** If you exit out of the Symbol Builder, restart it, and on the Select Symbol/Objects dialog box, click Select objects and select any graphics and attributes you added so far. You can then resume from where you left off.

---

- 1 In an AutoCAD drawing, draw the symbol graphics.

---

**NOTE** You can also create and modify the graphics for the symbol in the Block Editor environment.

---

- 2 Click Schematic tab ► Other Tools panel ► Symbol Builder drop-down



► Symbol Builder.

- 3 In the Select Symbol/Objects dialog box, Attribute template section, browse to the Library path where the one-line symbols are stored:

**Windows XP:** C:\Documents and Settings\All Users\Documents\Autodesk\Acade {version}\jic125\1-

**Windows Vista, Windows 7:** C:\Users\Public\Documents\Autodesk\Acade {version}\jic125\1-

- 4 In the Attribute template section, choose Symbol: Vertical Parent.

- 5 In the Attribute template section, choose Type: (CB) Circuit breakers.
- 6 In the Select from drawing section, click Select objects and select the graphics.
- 7 Select OK.

### Add attributes

In this part of the exercise, you insert some AutoCAD Electrical attributes from the Symbol Builder Attribute Editor. You are not limited to these attributes, and you can include your own user-defined attributes on the AutoCAD Electrical block files.

The TAG1 and WDTYPE attributes are the only required attributes for a one-line parent symbol. The other attributes in the Required section are expected on a one-line parent symbol, however the symbol is recognized as a one-line parent symbol without them.

The **WDTYPE** on page 325 attribute value must have a value of "1-" for a one-line symbol or "1-1" for a one-line **bus-tap** on page 659 symbol.

- 1 If the Symbol Builder Attribute Editor is not visible,  
Click Symbol Builder tab ► Edit panel ► Palette Visibility Toggle.



- 2 Select the TAG1 attribute.



- 3 Select the Properties tool to launch the Insert/Edit Attributes dialog box.

- 4 Change the height to 0.125 and Justify to Center.

The value is predefined as "CB" since the Circuit breaker template was selected. It is the default code used as the %F value of the tag format (such as "CR", "PB", "LT")

- 5 Select OK.



- 6 Click the Insert Attribute tool.
- 7 Select an insertion point for the attribute.

---

**NOTE** You can also right-click and select Insert Attribute or drag the attribute to insert it.

---

- 8  Select WDTYPE, click the Insert Attribute tool, and insert it. The WDTYPE attribute has a value of "1-" and is invisible by default. It is required to identify the symbol as a one-line symbol.

- 9  Select DESC1, click the Insert Attribute tool, and insert it below TAG1.

- 10 Repeat to insert the INST and LOC attributes above TAG1.

- 11 Select MFG, CAT, and ASSYCODE. Click the Insert Attribute tool, and insert them near the center of the rectangle.

---

**NOTE** If the CAT and ASSYCODE attributes are not listed they are inserted with MFG as a group.

---

- 12 Repeat to insert the FAMILY attribute near the center of the rectangle.

### Add wire connection attributes



You can define wire connection points for the library symbol. When you add a wire connection, you select the style, the direction the wire connects from, and whether to include the optional TERMxx and TERMDDESCxx attributes. In this exercise, wire connection attributes are inserted at the top and bottom of the symbol.

- 1 If the Symbol Builder Attribute Editor is not visible, Click Symbol Builder tab ➤ Edit panel ➤ Palette Visibility Toggle.



- 2 Expand the Wire Connection section of the Symbol Builder Attribute Editor.
- 3 Expand the Direction/Style list and select Top/None.

This style contains just the wire connection attributes with no graphics. Select Others to display the Insert Wire Connections dialog box for selecting other styles.

- 4  Select the Insert Wire Connection tool and insert the wire connection attributes. The wire connection attribute, X2TERM01, and the terminal pin attribute, TERM01, are inserted.
- 5 Back on the Symbol Builder Attribute Editor, expand the Wire Connection list and select Bottom/None.
- 6  Select the Insert Wire Connection tool and insert the wire connection attributes. The wire connection attribute, X8TERM02, and the terminal pin attribute, TERM02, are inserted.

### Finishing the one-line parent symbol



- 1 Click Symbol Builder tab ► Edit panel ► Done.
- 2 Click Base Point: Pick point and select the center of the symbol.
- 3 Select Wblock. Wblock creates the symbol .dwg file, while Block creates the symbol for this drawing file only.
- 4 Enter the Name and file path or keep the default. AutoCAD Electrical provides a default name for the new symbol based on the attribute template selected. Avoid changing the first four letters of the file name and limit the total length to 32 characters.

---

**NOTE** One-line symbols follow the same naming convention as schematic parent and child symbols. For convenience the one-line symbols provided have a "1-" suffix. However, the symbol name does not define the symbol as a one-line symbol.

---

- 5 (Optional) If you are going to add the symbol to the icon menu at a later time using the [Icon Menu Wizard](#) on page 1231, check Icon image. Enter the image name and folder.
- 6 (Optional) Click Details to see the [Symbol Audit](#) on page 359 dialog box listing potential issues with your symbol.

- 7 Select OK.
- 8 Select Close Block Editor from the block editor toolbar.
- 9 (Optional) Select Yes to insert the symbol on the drawing and select a location. If you place the component on an existing wire, the wire breaks. The component tag is assigned.

### See also:

- [Create a parent schematic symbol](#) on page 2083

## Convert a non-AutoCAD Electrical block

- 1 Click Schematic tab ► Other Tools panel ► Symbol Builder drop-down



- Symbol Builder.

- 2 Browse to the existing block to select the symbol to create or edit.
- 3 In the Select Symbol/Objects dialog box, Attribute template section: Browse to the Library path for example  
**Windows XP:** C:\Documents and Settings\All Users\Documents\Autodesk\Acade {version}\jic125  
**Windows Vista, Windows 7:** C:\Users\Public\Documents\Autodesk\Acade {version}\jic125
- 4 In the Attribute template section: Choose Symbol: Horizontal Parent for example.
- 5 In the Attribute template section: Choose Type: Generic for example.
- 6 Select OK.
- 7 Convert existing attribute or text objects to AutoCAD Electrical attributes.
- 8 Add [wire connections](#) on page 350 as needed.



- 9 Click Symbol Builder tab ► Edit panel ► Done.

A default symbol name is supplied which you can keep or change as needed depending on the symbol type and [symbol naming conventions](#) on page 282

## Converting attribute definition or text objects

If the existing symbol contains attribute or text objects you can convert these to the expected attributes for the symbol type.

- 1 If the Symbol Builder Attribute Editor is not visible,

Click Symbol Builder tab ► Edit panel ► Palette Visibility Toggle.



- 2  Select the Convert Text to Attribute tool to open the dialog box. All the attributes and text objects contained in your non-AutoCAD Electrical block are in the left-hand list. The AutoCAD Electrical attribute names are in the right-hand list.
- 3 Select an existing attribute/text from the left-hand list. Click the arrow next to the attribute in the right-hand list.
- 4 Repeat for each non-AutoCAD Electrical attribute or text object you want to convert.
- 5 Select Done.

## Create a panel footprint

A panel footprint symbol can be in either of two general forms: a to-scale physical representation of the device or a generic wiring diagram representation whose main purpose is to show wire connection annotation information.

The procedure for creating a panel footprint is like that of creating a schematic symbol with the following differences:

- Panel footprint symbols do not have to carry the wire connection attributes that schematic symbols almost always carry.
- There are no parent/child versions of a symbol for panel footprint symbols.
- Some of the attribute names are different. A panel symbol must have the P\_TAG1 or P\_TAGSTRIP attribute rather than the TAG1 or TAGSTRIP attribute.

- The symbol block naming for the panel footprint does not follow the special naming convention. The first four or five characters of the block name for a panel symbol is not as critical as it is for schematic symbols.

In this example, you take geometry (either geometry you just drew, existing geometry, or a vendor representation) and convert it to an AutoCAD Electrical panel footprint using the Symbol Builder.

- 1 Click Schematic tab ➤ Other Tools panel ➤ Symbol Builder drop-down



➤ Symbol Builder.

- 2 In the Select Symbol/Objects dialog box, Attribute template section, browse to the Library path

**Windows XP:** C:\Documents and Settings\All Users\Documents\Autodesk\Acade {version}\jic125

**Windows Vista, Windows 7:** C:\Users\Public\Documents\Autodesk\Acade {version}\jic125

- 3 In the Attribute template section, choose Symbol: Panel Footprint.
- 4 In the Attribute template section, choose Type: Generic.
- 5 In the Select from drawing section, click Select objects and select the existing objects or an existing block.
- 6 Select OK.

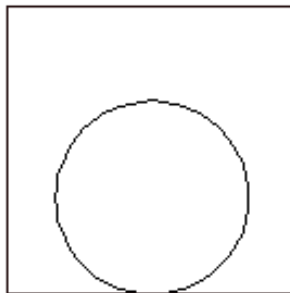



### Add attributes to the symbol

In this part of the exercise, you insert some AutoCAD Electrical attributes from the Symbol Builder Attribute Editor. You are not limited to these attributes and you can include your own user-defined attributes on the AutoCAD Electrical block files.

---

**NOTE** The P\_TAG1 attribute is the only one required for a panel footprint symbol. The other attributes in the Required section are expected on a panel footprint, however the symbol is recognized as a panel footprint without them.

---

- 1 If the Symbol Builder Attribute Editor is not visible,  
Click Symbol Builder tab ► Edit panel ► Palette Visibility Toggle.



- 2 Select the P\_TAG1 attribute.



- 3 Select the Properties tool to launch the Insert/Edit Attributes dialog box.
- 4 Change the height to 0.125, Justify to Center, and Visible.
- 5 Select OK.



- 6 Click the Insert Attribute tool.
- 7 Insert the attribute above the symbol graphics.

---

**NOTE** You can also right-click and select Insert Attribute or drag the attribute to insert it.

---



- 8 Select DESC1 and DESC2, click the Insert Attribute tool, and insert them below the P\_TAG1. Use the Properties tool to change them to Height = 0.125, Justify = Center, and Visible.

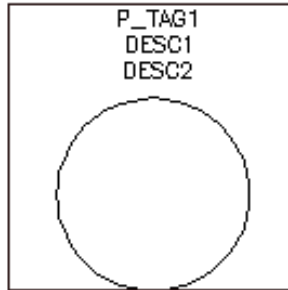

- 9 Insert the LOC, INST, MFG, CAT, and ASSYCODE attributes.

---

**NOTE** If the CAT and ASSYCODE attributes are not listed they are inserted with MFG as a group.

---

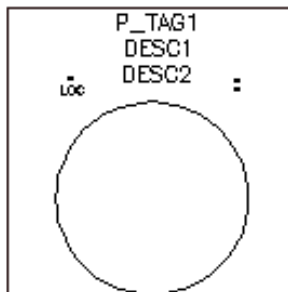

### Finishing the panel symbol



- 1 Click Symbol Builder tab ► Edit panel ► Done.
- 2 Click Base Point: Pick point and select the insertion point for the graphics.
- 3 Select Wblock. Wblock creates the symbol .dwg file, while Block creates the symbol for this drawing file only.
- 4 Enter the Name and file path or keep the default. AutoCAD Electrical provides a default name for the new symbol based on the attribute template selected.

- 5 (Optional) If you are going to add the symbol to the icon menu at a later time using the [Icon Menu Wizard](#) on page 1231, check Icon image. Enter the image name and folder.
- 6 (Optional) Click Details to see the [Symbol Audit](#) on page 359 dialog box listing potential issues with your symbol.
- 7 Select OK.
- 8 Select Close Block Editor from the block editor toolbar.
- 9 (Optional) Select Yes to insert the symbol on the drawing and select a location.

### Additional Options

The additional options for creating a symbol listed are not used for this example, but you can use them when creating your own symbol.

- **Optional Attributes:** The attributes listed in this section are allowed on a panel footprint. You can also add attributes to the Required or Optional list using the following steps.



- 1 Select the Add Attribute tool to launch the Insert/Edit Attributes dialog box.
- 2 Enter the attribute name as the Tag value.
- 3 Enter all property values.
- 4 Click Insert to insert the attribute or OK to add it to the list without inserting it.

- **RATING section:** You can add up to 12 Rating attributes. If the attribute template contains a RATING1 attribute, or you add one, this section is available on the Symbol Builder Attribute Editor.

- 1 Expand the RATING section.



- 2 Select the Add Next tool.
- 3 Pick an insertion point.

- **Convert Text to Attribute dialog box:** If you selected existing text entities from the Select Symbol/Objects dialog box, or added text while in the



You can set up to have visible attributes added to any footprint automatically at footprint insertion time. There are five attribute template drawings:

wd_ptag_addattr_comp.dwg	component footprints
wd_ptag_addattr_trm.dwg	terminal with terminal number
wd_ptag_addattr_wtrm.dwg	terminal with wire number as terminal number
wd_ptag_addattr_itemballoon.dwg	balloons
Wd_ptag_addattr_pnltermstrip.dwg	terminal footprints (when inserted by Level/Sequencing tools)

When a panel footprint is inserted, the following steps are performed if the appropriate attribute template exists.

- 1 Find the center of the footprint by collecting and averaging the objects that make up the footprint.
- 2 Insert the attribute template at the calculated center of the footprint.
- 3 Make sure there are no duplicate attributes. If duplicate attributes are found, the attribute from the footprint is kept.
- 4 Re-block the added attributes with the inserted footprint.
- 5 Add the schematic data to the footprint. The data is added as attribute data if the target attribute exists. If the target attribute does not exist, the data is added as invisible xdata.

## Create a Symbol Builder attribute template

Symbol Builder provides some family attribute templates. Each template contains the required and optional attributes for a certain type of symbol. Based on the options selected on the Select Symbol/Objects dialog box in Symbol Builder, an attribute template is used. The attributes on the template are listed in the Symbol Builder Attribute Editor making it easy to insert them on your symbol.

AutoCAD Electrical does not provide an attribute template for every type of symbol. Consider creating your own if you expect to create a number of new symbols. There are three basic steps to creating a Symbol Builder attribute template.

---

**NOTE** Wire connection attributes are not included in the symbol attribute templates but are in separate [wire connection templates](#) on page 2107.

---

- 1 Create a drawing file following the naming convention “AT\_{symbol}\_{type}.dwg” containing the AutoCAD Electrical attribute definitions.
- 2 (Optional) Add the xdata and indexed attributes which tell the Symbol Builder Attribute Editor how to handle each attribute.
- 3 (Optional) Add the symbol type to the “\_FAMILY\_DESCRIPTION” table in the catalog database file.

### Attribute template naming convention

Attribute templates follow the naming convention, AT\_{symbol}\_{type}. The {symbol} and {type} values appear in the lists on the [Select Symbol / Objects](#) on page 342 dialog box. The selections from these lists direct Symbol Builder to the appropriate attribute template.

The {symbol} value appears in the Symbol list in the Select Symbol/Objects dialog box. Certain codes are recognized by Symbol Builder, such as “HP” for “Horizontal Parent”. You can use an existing recognized code or use the full text, such as “AT\_Horizontal Parent\_{type}.dwg”.

The {type} value appears in the Type list in the Select Symbol/Objects dialog box. You can also map abbreviations for the {type} in the \_FAMILY\_DESCRIPTION table of the catalog database, default\_cat.mdb.

### Indexed attributes and xdata

An attribute template can contain an attribute definition that can be indexed. For example, AutoCAD Electrical allows up to 12 Rating attributes. If the attribute template contains an attribute “RATING(x)” this attribute can be indexed in Symbol Builder.

Certain optional xdata directs the attribute display in the Symbol Builder Attribute Editor. Use the [Xdata Editor](#) on page 1694 to add or modify the xdata on an attribute definition.

VIA_WD_GROUP	Possible values "Required" or "Optional". The default value is “Required” if the xdata is not present.
VIA_WD_TOOLTIP	The value provides an attribute description inside the Symbol Builder Attribute Editor.

<b>VIA_WD_MULTIATT</b>	<p>The value defines a group of attributes to insert together. The value lists all the attributes which are inserted along with the attribute with this xdata. The attributes listed are not displayed in the Symbol Builder Attribute Editor. For example, if you want DESC2 and DESC3 inserted when you insert DESC1, add this xdata with the value "DESC2,DESC3" to the DESC1 attribute definition.</p> <hr/> <p><b>NOTE</b> MFG, CAT, and ASSYCODE are a default group. To insert them separately, add this xdata to the MFG attribute with a blank value.</p> <hr/>
<b>VIA_WD_INDXMAX</b>	<p>The value provides the maximum number of times to index an attribute such as "RATING". The default value is "12" if the xdata is not present.</p>
<b>VIA_WD_SEQ</b>	<p>The value provides the display order.</p>

### Symbol type

Edit the "\_FAMILY\_DESCRIPTION" table in the catalog database, default\_cat.mdb, to map the symbol name type value to a description. This description is used in the Type list on the [Select Symbol / Objects](#) on page 342 dialog box. For example, if the attribute template name is "AT\_HP\_PS.DWG" but you want "Power Supply" shown in the list on the dialog box, add an entry with "PS" in the Family column, and "Power Supply" in the Description.

### Creating a custom wire connection style

Symbol Builder inserts a wire connection template drawing when adding a wire connection to your symbol. The list of wire connection styles is built dynamically based on the template drawings found in the symbol library path. The wire connection template name indicates that it is a wire connection template, the wire connection type, and direction.

AutoCAD Electrical comes with some schematic wire connection styles. If additional styles are needed, create the wire connection templates for a new style. To create a complete style, create a wire connection template for each wire direction. To add a new schematic style, create the following wire connection template drawings.

- BB?11.dwg
- BB?12.dwg
- BB?13.dwg

- BB?21.dwg
- BB?22.dwg
- BB?23.dwg
- BB?31.dwg
- BB?32.dwg
- BB?33.dwg

The “?” is replaced with the next available digit. AutoCAD Electrical allows up to ten styles using the digits 0-9. You can create them using new drawings or by copying a set of existing wire connection template drawings to the appropriate names and modifying as needed.

### **Starting a wire connection template from a new drawing**

- 1 Start a blank new drawing.
- 2 Draw the graphics for the wire connection.
- 3 Use the AutoCAD ATTDEF command to add the wire connection attribute definition. The insertion point of the attribute definition is the location AutoCAD Electrical uses to connect the wire. The wire connection attribute tag is X?TERM01. The "?" character position is used to identify the preferred wire connection direction:
  - 1: wire connects to the attribute from the right
  - 2: wire connects to the attribute from above
  - 4: wire connects to the attribute from the left
  - 8: wire connects to the attribute from below
  - 0: special for motor connections that radiate from a circle
- 4 (Optional) Add the TERM01 attribute definition.
- 5 (Optional) Add the TERMDDESC01 attribute definition.
- 6 (Optional) Add a custom drawing property to define the style description. This value is the text displayed in the terminal style list in Insert Wire Connections dialog box.
  - Select File ► Drawing Properties.
  - Select the Custom tab.



- Select Add.
  - Enter “Terminal style” for the custom property name.
  - Enter the style description for the value.
  - Select OK to save the drawing property.
- 7 Save the drawing to the appropriate library folder following the wire connection template naming convention.

### Wire connection template naming convention

- First two characters are “BB”.
- Optional characters which indicate the symbol type for this wire connection.

<b>Blank</b>	Parent or child schematic symbol
<b>PTWN</b>	Panel footprint or nameplate
<b>STTN</b>	Schematic terminal with terminal number
<b>STWN</b>	Schematic terminal following the wire number
<b>PTWN_NOTERM</b>	Panel terminal

- One or two characters indicating the terminal style. It is a single number, 0 through 9, for schematic symbols. For a panel symbol, the single number is followed by an underscore.
- Last two characters are digits that indicate the wire direction.

<b>00</b>	Radial, wire connects from an angle
<b>11</b>	Left and top
<b>12</b>	Left
<b>13</b>	Left and bottom
<b>21</b>	Top
<b>22</b>	Top, left, bottom, and right
<b>23</b>	Bottom

- 31 Right and top
- 32 Right
- 33 Right and bottom

### Supplied wire connection templates

Template Name	Symbol Type	Terminal Style	Attributes in the template
BB012, BB021, BB023, BB032	Schematic parent or child	None	X?TERMn, TERMn
BB000	Schematic parent or child	None	X0TERMn
BB111 to B133	Schematic parent or child	Screw	X?TERMn, TERMn
BB211 to BB233	Schematic parent or child	Small Screw	X?TERMn, TERMn
BB311 to BB333	Schematic parent or child	Circle, number inside	X?TERMn, TERMn
BB411 to BB433	Schematic parent or child	Square, number inside	X?TERMn, TERMn
BB511 to BB533	Schematic parent or child	Fixed PLC	X?TERMn, TERMn, DESCA01, DESCRB01, TAGA01
BBSTTN012, BBSTTN021, BBSTTN023, BBSTTN032	Schematic terminal with terminal number	None	X?TERM01, TERM01
BBSTWN012, BBSTWN021, BBSTWN023, BBSTWN032	Schematic terminal following wire number	None	X?TERM01
BBPTWN0_12, BBPTWN0_21,	Panel footprint	One wire number	X?TERMn, TERMn, TERMDESCn, WIRENO

Template Name	Symbol Type	Terminal Style	Attributes in the template
BBPTWN0_23, BBPTWN0_32			
BBPTWN1_12, BBPTWN1_21, BBPTWN1_23, BBPTWN1_32	Panel footprint	One wire number	X?TERMn, TERMn, TERMDESCn, WIREOn
BBPTWN2_12, BBPTWN2_21, BBPTWN2_23, BBPTWN2_32	Panel footprint	Two wire numbers	X?TERMn, TERMn, TERMDESCn, WIREOn, WIREOnA
BBPTWN_NOTERM0_12, BBPTWN_NOTERM0_21, BBPTWN_NOTERM0_23, BBPTWN_NOTERM0_32	Panel terminal, no levels	No levels	WIRENOL, WIRENOR, TERM, TERMDESCL, TERMDESCR
BBPTWN_NOTERM1_12, BBPTWN_NOTERM1_21, BBPTWN_NOTERM1_23, BBPTWN_NOTERM1_32	Panel terminal, one level	One level terminal	WIRENOL, WIRENOR, L01PINL, L01PINR, TERM
BBPTWN_NOTERM2_12, BBPTWN_NOTERM2_21, BBPTWN_NOTERM2_23, BBPTWN_NOTERM2_32	Panel terminal, two levels	Two level terminal	WIRENOL, WIRENOR, L01PINL, L01PINR, TERM, L02WIRENOI, L02WIRENOR, L02PINL, L02PINR, L02TERM
BBPTWN_NOTERM3_12, BBPTWN_NOTERM3_21, BBPTWN_NOTERM3_23, BBPTWN_NOTERM3_32	Panel terminal, three levels	Three level terminal	WIRENOL, WIRENOR, L01PINL, L01PINR, TERM, L02WIRENOI, L02WIRENOR, L02PINL, L02PINR, L02TERM, L03WIRENOL, L03WIRENOR, L03PINL, L03PINR, L03TERM

The “?” is replaced with the appropriate [wire connection direction number](#) on page 312 and the “n” is replaced with the two digit sequential number. If your template contains only one wire connection attribute, always use “01”. The “01” is replaced with the next available value when the wire connection template is inserted using Symbol Builder.

## Add your own symbols, circuits, and commands to the icon menu

AutoCAD Electrical supplies two default icon menus: one for schematic symbols and the other for panel symbols. Each menu is driven by a text file. AutoCAD Electrical defaults to icon menu ACE\_<standard>\_MENU.DAT (where <standard> = JIC, IEC, GB, HYD, JIS, PID, or PNEU) for schematic symbols and ACE\_PANEL\_MENU.DAT for panel symbols. These menu files are located in

- **Windows XP:** C:\Documents and Settings\{username}\Application Data\Autodesk\AutoCAD Electrical {version}\{release}\{country code}\Support\
  - **Windows Vista, Windows 7:** C:\Users\{username}\AppData\Roaming\Autodesk\AutoCAD Electrical {version}\{release}\{country code}\Support\
    - **Add component:** Inserts a symbol
    - **Add circuit:** Inserts a prebuilt circuit. This causes AutoCAD Electrical to insert and explode the .dwg name supplied.
    - **Add new submenu:** Starts a new submenu.
    - **Add command:** Performs a command. Use Command for inserting three-phase schematic symbols and panel footprints.

You modify or expand the icon menus by editing the underlying icon menu text file. You can use a generic text editor and edit it manually or you can use the AutoCAD Electrical Icon Menu Wizard.

Use the Icon Menu Wizard dialog box to select the function to be performed when the icon is selected from the icon menu.

### Add components to the icon menu

The Icon Menu Wizard can be used to add or modify icons for both the schematic and panel symbol libraries.

- 1 Create an AutoCAD Electrical compatible library symbol. For schematic symbols, follow the guidelines regarding the symbol ".dwg" file [naming convention](#) on page 282 and [required attributes](#) on page 306.



- 2 Click Schematic tab ► Other Tools panel ► Icon Menu Wizard.
- 3 In the Select Menu File dialog box, select to modify the schematic menu file, and click OK.
- 4 In the Icon Menu Wizard dialog box, select Add ► Component to add a new icon to the menu.

---

**NOTE** You can also right-click in empty space and select Add icon ► Component.

---

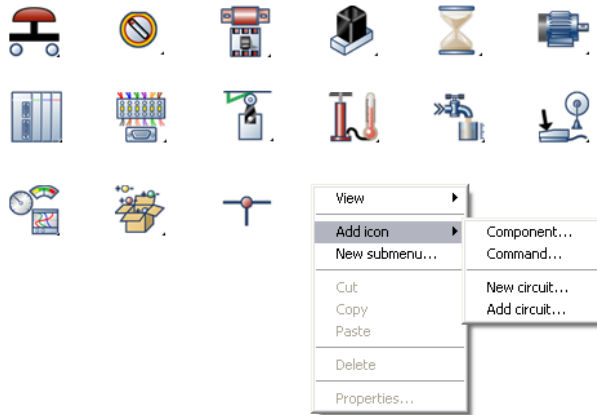

Three pieces of information are needed for the new icon button.

- 5 On the Add Icon - Component dialog box, specify the image file name and graphic to appear in the icon button. The image name can be manually typed into the edit box. You can browse to an existing .sld or .png file to assign to the icon, use an image file that matches the active drawing name, use an image file that matches a picked block on the drawing, or use an image with the same name as the block name entered for the block name.

---

**NOTE** Browse cannot be used if you are using a slide library (instead of individual <slide>.sld files). Manually enter these as "library name(slide name)". For example, "S1(hpb11)."

---

If you have not created the slide image and want to have it created automatically from the current screen image, select Create PNG from current screen image. The Icon Menu Wizard runs the AutoCAD MSLIDE

command on your current screen image to create the .png and .sld file. If the file does not exist, then Create PNG from the current screen image is selected by default. If you do not want to create the image from the current drawing's displayed image, switch it off. If you want to redo an existing image, click this switch on.

- 6 Specify the block name to insert on the icon. The symbol's file name can be typed into the edit box or you can browse for an existing WBlockd ".dwg" file to assign to the icon, insert the full active drawing as a block, or select an existing block on the current drawing.
- 7 Click OK.

The new menu button appears in the menu and the text you entered for the icon label appears in the tooltip or in the list if you set the viewing option to either Icon with text or List view.

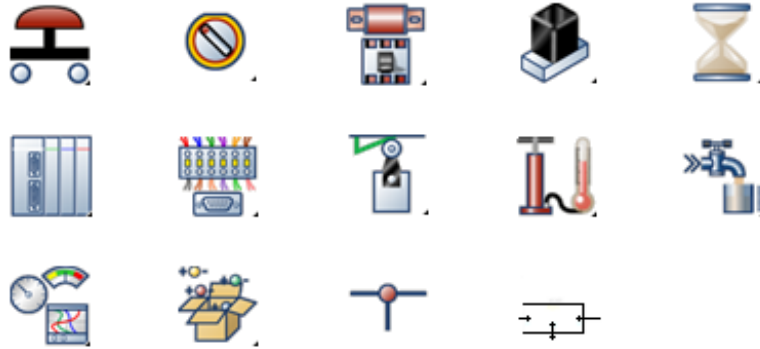

- 8 Select the appropriate Insert Component command and test your new symbol insert.

### Add an icon menu page

You can add new menu pages to the AutoCAD Electrical icon menu, and then populate them with your own custom symbols. Each new page can have icon selections that cascade down to other new menu pages. Once you click OK, your trigger icon and new submenu page are added.

- 1 On the Icon Menu Wizard dialog box, select Add ► New submenu to add a new icon to the menu.

---

**NOTE** You can also right-click in empty space and select New Submenu.

---

The Create New Submenu dialog box appears. Here you can select the function that will be performed when the icon is selected from the icon menu.

Three pieces of information are needed to trigger the new menu page.

- 2 On the Create New Submenu dialog box, specify the image file name and .sld or .png graphic to appear in the icon button. The image name can be manually typed into the edit box. You can browse to an existing .sld or .png file to assign to the icon, use an image file that matches the active drawing name, use an image file that matches a picked block on the drawing, or use an image file with the same name as the block name entered for the block name.

---

**NOTE** Browse cannot be used if you are using a slide library (instead of individual <slide>.sld files). Manually enter these as "library name(slide name)".

---

- 3 Specify the submenu's title.
- 4 Click OK.
- 5 Select the appropriate Insert Component command and test your new symbol insert.

### **Add an icon to trigger a command**

An icon can be configured to trigger an AutoCAD command, trigger an AutoCAD Electrical command, or run a program. For example, "Rectangle" can be typed into the edit box so that every time you click the box, it runs the AutoCAD Rectangle command.

- 1 On the Icon Menu Wizard dialog box, click Add ► Command.

---

**NOTE** You can also right-click in empty space and select Add icon ► Command.

---

- 2 On the Add Icon - Command dialog box, specify the name to appear on the icon and the image file to use on the icon button.
- 3 Specify the command to execute when the icon button is selected.  
Click List to select from a list of AutoCAD Electrical Commands for Panel and Schematic multi-pole symbol inserts. This makes it easier for you to build the appropriate command to insert a multi-pole symbol or a panel symbol. To see the command line parameters for a specific AutoCAD Electrical command, select the command in the list and the parameters

display at the right. If quotation marks are shown, then enclose the parameter value within quotation marks.

---

**NOTE** If you select an API command that requires parameters you must manually enter the additional parameters as indicated. Commands that require parameters should be inside of parenthesis. If you use one of the AutoCAD commands from the list, no parenthesis are needed. For example, to add an icon that inserts a black flush push button, Allen-Bradley, catalog number 800T-A2A, with no rotation, select the command WD\_INFP from the list. When you return to the Command dialog box, you must enter in the rest of the parameters.

---

- "family" is used for the catalog file lookup table name
- "mfg" is used for the footprint lookup
- "cat" is the actual catalog number
- "assycode" is the catalog number assembly code (often blank)
- "footprint" is the library symbol name

WD\_INFP "PB11" "AB" "800T-A2A" "" "AB/ABPB3"

4 Click OK.

### Add circuits to the icon menu

Add Circuit is the same as Insert Command except that the block file is made up of more than one AutoCAD Electrical block definitions and related wire lines.

1 On the Icon Menu Wizard dialog box, click Add ► Add circuit.

---

**NOTE** You can also right-click in empty space and select Add icon ► Add circuit.

---

Three pieces of information are needed for the new icon button.

2 On the Add Existing Circuit dialog box, specify the image file name and .sld or .png graphic to appear in the icon button. The image name can be manually typed into the edit box. You can browse to an existing .sld or .png file to assign to the icon, use an image file that matches the active drawing name, use an image file that matches a picked block on the drawing, or use an image file with the same name as the block name entered for the block name.



---

**NOTE** Browse cannot be used if you are using a slide library (instead of individual <slide>.sld files). Manually enter these as "library name(slide name)".

---

- 3 Specify the circuit name to insert on the icon. The symbol's file name can be typed into the edit box or you can browse for an existing WBlocked ".dwg" file to assign to the icon or insert the full active drawing as a block.
- 4 Click OK.  
The new menu button appears in the menu.
- 5 Select the appropriate Insert Component command and test your new symbol insert.

### Change the icon's image

There are times when you might want to change the image associated with an icon menu choice. The AutoCAD Electrical Icon Menu Wizard provides a quick, easy way to reassign or reshoot a slide image. Slides can be saved as individual files in the AutoCAD Electrical search path or they can be maintained inside of a library of slide files called the slide library.

---

**NOTE** If you make custom slides or slide libraries for the menu, copy them to the same subdirectory as the menu file since AutoCAD Electrical looks for menu slides in the active icon menu file's directory.

---

- 1 On the Icon Menu Wizard dialog box, right-click an icon button to edit and select Properties.
- 2 On the Properties dialog box, specify the image file name and .sld or .png graphic to appear in the icon button. The image name can be manually typed into the edit box. You can browse to an existing .sld or .png file to assign to the icon, use an image file that matches the active drawing name, use an image file that matches a picked block on the drawing, or use an image file with the same name as the block name entered for the block name.

If you have not created the .png image and want to have it created automatically from the current screen image, select Create PNG from current screen image. The Icon Menu Wizard runs the AutoCAD MSLIDE command on your current screen image to create the .png and .sld file. If the file does not exist, then Create PNG from current screen image is selected by default. If you do not want to create the image from the current drawing's displayed image, switch it off. If you want to redo an existing image, click this switch on.

---

**NOTE** Browse cannot be used if you are using a slide library (instead of individual <slide>.sld files). Manually enter these as "library name(slide name)".

---

- 3 Click OK.  
The new menu button appears in the menu.
- 4 Select the appropriate Insert Component command and test your new symbol insert.

### Edit the DAT file with a text editor

There may be times when you want to bypass the Icon Menu Wizard and edit the menu DAT file directly. It is important to maintain the menu file structure, otherwise your menu may not activate properly. An AutoCAD Electrical menu ".dat" file is a text file that can be viewed and edited with any text editor (ex: WordPad or Notepad). See [Overview of the icon menu file](#) on page 1260.

### Best practices for icon menu changes

We recommend that you create your own icon menu and leave the AutoCAD Electrical icon menu intact. This provides you with easier migration when upgrading to the next version of AutoCAD Electrical. You can set up the AutoCAD Electrical icon menu system so that you can flip back and forth between the default ACE\_<standard>\_MENU.DAT (such as ACE\_JIC\_MENU.DAT) and your own "my\_menu.dat."

- 1 Copy the standard menu into a new file name instead of creating the file from scratch. Open the new DAT file with a text editor and remove everything except for the top portion of the file (shown below).

```
**M0  
D0  
JIC: Schematic Symbols
```

---

**NOTE** The line "D0" is only needed if the menu must be compatible with AutoCAD Electrical versions prior to 2008.

---

Rename the title line to indicate that this is your very own personal menu file.

- 2 Add a line like the following in the ACE\_<standard>\_MENU.DAT file.  
My schematic menu\mymenu.sld!\$C=(c:wd\_loadmenu  
"my\_menu.dat")(c:wd\_insym\_go2menu 0)

---

**NOTE** Make sure this text is all on one line.

---

- 3 In your new "my\_menu.dat" file, add a line like the following one so that you can jump back to the default AutoCAD Electrical icon menu.

```
Default AutoCAD Electrical menulback2wd.sldl$C=(c:wd_loadmenu  
"ACE_JIC_MENU.DAT")(c:wd_insym_go2menu 0)
```

The result should be:

```
**M0
```

```
D0
```

```
My Menu: My Companies Symbols
```

```
AutoCAD Electrical menulback2wd.sldl$C=(c:wd_loadmenu  
"ACE_JIC_MENU.DAT")(c:wd_insym_go2menu 0)
```

- 4 In the AutoCAD Electrical default icon menu, click the new "My menu" entry.

Your menu should immediately appear and remains the default for subsequent component inserts. If you want to go back to the AutoCAD Electrical default menu, click the "AutoCAD Electrical menu" button you added to your custom menu. AutoCAD Electrical flips back to the default icon menu and it now remains the default for subsequent inserts.

## Configure projects for various drawing standards

AutoCAD Electrical has multiple configuration options so that you can configure your drawings in a manner that fits your needs. You can configure drawings for IEC standard or automatically override family tag codes.

### Configure for IEC standard

Below is a list of configuration options (both project properties and drawing-specific properties) that are most commonly used when dealing with the IEC drawing standard and a description of each.

#### Project Properties

Project Properties are configured by right-clicking on the project name in the Project Manager and selecting Properties. The options configured here are project-wide options, such as the paths to symbol libraries, or drawing default options for new drawings that are created in the selected project. The drawing

options defined in the Project Properties dialog box can also be applied to any drawing in the project if needed.

## Project Settings Tab

### Schematic Libraries

AutoCAD Electrical contains two specific IEC-type symbols, IEC2 and IEC4. The main difference between these libraries is the size of the text associated with them.

- IEC2 symbols have a text size of 2.5 for the main text items such as Component Tag, Installation, Location, Component Description, and so on.
- IEC4 symbols have a text size of 3.5 for the Component Tag and a text size of 2.7 for Installation, Location, Component Description, and so on.

### Schematic Icon Menu File

AutoCAD Electrical contains one IEC-specific icon menu file: ACE\_IEC\_MENU.DAT.

## Components Tab

### Component TAG Format

In IEC you may want your components to be tagged with “Sheet Number, Family Code,” followed by a number that is either sequential or reference-based. To do this, in the Tag Format edit box, enter: “%S%F%N” where %S = the sheet number, %F = the family code defined for the component being inserted and %N = the numbering scheme for the active drawing (either sequential or reference-based).

For sequential numbering, you can enter a starting number to use as a starting component number.

For reference-based numbering, you can use one of the following numbering formats:

- X-Y Grid
- X Zones
- Reference Number

## Components Tab

### Component TAG Options

Defines most of the specific tagging options to conform to the IEC tagging mode. Select the option that best fits your needs:

- **Combined Installation/Location Tag Mode:**  
Uses the combined installation/location tag for interpreting component tag names. For example, 100CR relay contact marked with location code PNL1 is interpreted as being associated with a different relay coil than relay contact -100CR marked with location code PNL2. If this setting is not selected, both contacts are associated with the same parent relay coil, -100CR.

By selecting this option, your component tags are automatically prefixed with the =, +, and - where applicable.

- **Suppress dash when first character of tag:**  
Suppresses any single dash character prefix in an IEC tag that does not have a leading Installation/Location prefix (for example, "-K101" dash is suppressed to "K101" but "+LOC1-K101" remains unchanged).

When switched OFF, it automatically adds a single dash character to an IEC tag that does not already have a single leading dash prefix and does not have a leading Installation/Location prefix. For example, tag "K101" becomes "-K101" but "+LOC1-K101" remains unchanged.

---

**NOTE** This suppression takes place automatically in reports; and takes place graphically only when a component is inserted, edited, or retagged.

---

- **Format Installation/Location into tag:** Specifies to exclude the Installation and Location code values as part of the tag when displaying. For example, if this is not on, a tag might show up

## Components Tab

as K16 in the Surf dialog box. But if selected, the tag might show up +AAA-K16 (where AAA is the location).

- Suppress Installation/Location in tag when match drawing default: Suppresses Location and Installation values on components if they match the drawing default values.
- Suppress Installation/Location in tag on reports: Specifies to exclude Installation and Location values as part of the tag when displayed in reports.
- Upon insert: automatic fill Installation/Location with drawing default or last used: Fills the Installation and Location edit boxes on the Insert/Edit component dialog box and the attributes on the block with drawing default or last used values (if no drawing default). If not selected, these edit boxes and attributes are not filled in and are assumed.

## Cross-reference Tab

### Cross-reference Format

In IEC, you may want to configure your cross-referencing text to display the "Sheet Number - Reference Number." To do this, in the Same Drawing edit box, enter "%S-%N" (or click the %S-%N button). You can also define the format of the cross-referencing text that references other drawings in the Between Drawings edit box.

### Suppress Installation/Location codes when matching the drawing defaults

Select this if you want to suppress IEC prefixes.

---

**NOTE** You must run the Component Cross-reference command to update any existing cross-referencing text.

---

### Component Cross-reference Display

In IEC, it is common to display a representation of the type of child component (Normally Open, Normally Closed or Form-C contact) in either a graphical or table format. If you select the graphical

## Cross-reference Tab

(nontable) format, you can define details of the graphical format by clicking Setup.

## Styles Tab

### Wire Style

In IEC, it is sometimes preferable to display wire connections as tee markers instead of connection dots. To do this, in the Wire Tee section, select the appropriate angle tee marker from the list.

## Drawing Format Tab

### Ladder Defaults

In IEC, the most common ladder orientation is Horizontal. In the Ladder Defaults section, configure how to display your horizontal ladders.

### Format Referencing

Defines the type of referencing that is used to replace the %N value for component tag and wire number formats. In IEC, the most commonly used format is X Zones.

---

**NOTE** If you want AutoCAD Electrical to place the labels for the X-Y Grid or X Zones referencing style, use the appropriate command from the Insert Ladder toolbar.

---

- X-Y Grid: All referencing is tied to an X-Y grid system of numbers and letters along the left-hand side and top of the drawing. Set your drawing's vertical and horizontal index numbers and letters, spacing, and origin in the X-Y grid setup dialog box.

---

**TIP** Use negative spacing values for Horizontal or Vertical if you want to change the X-Y grid system's origin to be other than the upper left-hand corner of the drawing

---

- X Zones: Similar to X-Y Grid, but there is not a Y-axis. Set your drawing's horizontal labels,

## Drawing Format Tab

spacing, and origin on the X Zones setup dialog box.

---

**TIP** Use negative zone spacing value if you want the zone reference origin to be at the right side of the drawing.

---

## Scale

Scale for IEC drawings is normally set to mm full size.

## Drawing Properties

Drawing Properties are configured by either right-clicking on the drawing name in the Project Manager and selecting Properties ► Drawing Properties, or by selecting Properties ► Drawing Properties. The options configured here are only applied to the drawing that they were configured on.

---

**NOTE** Options that are duplicated on the Drawing Properties and Project Properties dialog boxes are not described in this section.

---

## Drawing Settings Tab

### IEC-Style Designators

Defines Installation and Location codes that are used for drawing defaults when placing components on the drawing and no override Installation or Location values are given on the specific component. These values are used when the Combined Installation/Location tag mode option is selected (described previously in Project Properties section).

### Automatically override family tag codes

A component's family name can be overridden at insertion time, during a later edit, or automatically using the wd\_fam.dat mapping file. The wd\_fam.dat file overrides the family tag code of library symbols by mapping the codes to new values. The tag code of a symbol is used in generating the tag-ID of inserted components, such as the "PB" of tag-ID "PB101."

AutoCAD Electrical searches for this mapping file in the following order:

- 1 User subdirectory



**Windows XP:** C:\Documents and Settings\{username}\Application Data\Autodesk\AutoCAD Electrical {version}\{release}\{country code}\Support\User\

**Windows Vista, Windows 7:**

C:\Users\{username}\AppData\Roaming\Autodesk\AutoCAD Electrical {version}\{release}\{country code}\Support\User\

- 2 Active project's .wdp file subdirectory
- 3 All paths defined under AutoCAD Options ► Files ► Support Files Search Path

Depending on how you want to override component family names, you can move the wd\_fam.dat file into the various locations mentioned above.

- To always substitute a new family value for all projects you create, place the file in the User folder. (option 1)
- To use AutoCAD Electrical defaults most of the time but sometimes override them with project-specific defaults, place the file in the project folders for the project you want to override. You can have different defaults for each project. (option 2)
- If you want a default override from the AutoCAD Electrical default values, but sometimes want a project override to the global override, you will want to use option 3 and 2. Place the file somewhere in the AutoCAD support path, like "C:\Program Files\Autodesk\Acade 200x\Acade," and then when you want to override these values, place the file in the project folder.

## Switch JIC and IEC standards

You can have projects that require working in the JIC standard and other projects that require the IEC standard. To switch from one standard to another change:

- Schematic library folders
- Schematic icon menu
- Component tagging options

The library folders and icon menu are project settings. The component tagging options are on a per-drawing basis and must be applied to each drawing.

## Project settings

- 1 Click Project tab ► Project Tools panel ► Manager. 
- 2 Right-click on the project name in Project Manager.
- 3 Select Properties.
- 4 Select the Project Settings tab.
- 5 Expand the Schematic Libraries section.
- 6 Remove any folder names you no longer want and add any that you need. For example, remove the JIC folder and add the IEC library folder.

---

**NOTE** AutoCAD Electrical searches for a symbol in the order the folders are listed.

---

- 7 Expand the Schematic Icon Menu File section.
- 8 Remove the menu you do not want and add the menu you need. For example, remove the ACE\_JIC\_MENU.DAT file and add the ACE\_IEC\_MENU.DAT file.
- 9 Click OK.

## Drawing settings - change as a project setting

Component tagging options can be changed as a project setting and applied to a group of drawings.

- 1 Click Project tab ► Project Tools panel ► Manager. 
- 2 Right-click on the project name in Project Manager.
- 3 Select Properties.
- 4 Select the Components tab.
- 5 In the Component TAG Options section, check the Combined Installation/Location tag mode option for IEC tagging, uncheck it for JIC tagging.  
If using IEC tagging, set any of the other tagging options.

- 6 Highlight all the drawings in Project Manager you wish to apply the project settings to.
- 7 Right-click and select Properties ► Apply Project Defaults.

---

**NOTE** When the project settings are applied to a drawing, all settings are applied, not specific ones.

---

### Drawing settings - change a single drawing

Component tagging options can be changed on a per-drawing basis.

- 1 Click Project tab ► Project Tools panel ► Manager. 
- 2 Highlight the drawing in Project Manager that you wish to change.
- 3 Right-click and select Properties ► Drawing Properties.
- 4 Select the Components tab.
- 5 In the Component TAG Options section, check the Combined Installation/Location tag mode option for IEC tagging, uncheck it for JIC tagging.  
If using IEC tagging, set any of the other tagging options.
- 6 Click OK.

---

**NOTE** You can change the component tagging options on the active drawing by

selecting Drawing Properties. 

---

### See also:

- [Configure for IEC standard](#) on page 2119

## Use Autodesk Vault with AutoCAD Electrical

Autodesk Vault allows you to keep a history of your design changes. You can review how your designs have progressed and rollback to a previous version if necessary. Vault also acts as a central shared secured repository of drawings

and data with the ability to search for required information across multiple drawings and projects.

The AutoCAD Vault add-in works within AutoCAD Electrical, adding data management tools to the interface. Through the AutoCAD Vault add-in, you can add files to a vault, and check files in and out. The add-in works with both DWG and image files. In AutoCAD Electrical, you work on one project at a time. The project file (.wdp) lists all the drawings that are part of a project. When you make a change in one drawing, all files related to that drawing automatically update.

### **Perform vault tasks with the Project Manager**

When working with AutoCAD Electrical and Autodesk Vault, you check out projects or individual drawings from a vault location to edit. You can perform all vault tasks within the Project Manager when you are logged into the vault. You can also manage the relationships between a project file and its dependents in the vault, while standard project management operations continue to be available.

---

**NOTE** Access to vault folders depends upon the permissions you are granted. You cannot see files or folders that you do not have permissions for viewing.

---

AutoCAD Vault ARX adds vault features to the Project Manager once logged into the Vault. The vault commands are available by right-clicking on a project or drawing within the AutoCAD Electrical Project Manager. You can use the Project Manager to:

- **Log in and out of the vault**

Upon initial start-up of AutoCAD Electrical, you are not logged into the vault. You must log into Autodesk Vault to work with projects in the vault. You can also log into the vault using the File ► Vault menu

- **Check projects in and out of the vault**

The most basic requirement of the vault is that you never work directly on a file in the vault. You must check out the project to the working folder on your local drive to edit it. When you finish working on the project, you must check the project back into the vault.

When a project file and its related drawing files are checked out of a vault, only the files that are not currently checked out are downloaded. If the working copy of a file is older than the version in the vault, you are prompted to replace the working copy. If the working copy is currently checked out, it is not replaced.

---

**TIP** If you want others to view updates you made to a project and you want to continue modifying the project, select the Keep Checked Out option on the Check In dialog box. This checks in the updates you made to the project and keeps the project checked out to you.

---

**NOTE** You must have all references of a project file downloaded to your working folder to edit the project file.

---

■ **View the status of files in a design**

The status icons indicate the status of your local files as compared to the same files in the vault. You can tell when the local copy is in sync with the vault and when it is not. The tooltip for each status icon describes the state of the file and suggests the next logical step. The status of a local file is updated when it is saved to disk.

---

**NOTE** The vault status icons are only available in the list view and only appear when you are logged into the vault.

---

### **Setup for single user vs. multiple users**

You can perform vault operations on the entire project or individual drawing files listed within the project in AutoCAD Electrical. However, in a multiple-user design environment, you can choose to check out and edit individual files as they are needed rather than checking out the entire project at once while still maintaining drawing file dependencies and versions. After you change the files and check them back into the vault, the associated files simultaneously update.

Use the Project Manager to perform all vaulting operations. In AutoCAD Electrical, you can select a file (or multiple files) within a project to:

- Check in (all)
- Check out (all)
- Get latest (all)

### **Workflow overview**

- 1 Start AutoCAD Electrical.
- 2 Log into Vault.

- 3 In a single user environment, if you did not set a working folder yet, start Autodesk Vault Explorer and set a working folder on your local computer and then switch back to AutoCAD Electrical.  
In a multiple-user design environment, set the working folder on a shared network resource for the entire project team. This allows simultaneous access for all users on the same dataset and maintains the data consistency.
- 4 Open a project you want to add to the vault.
- 5 Add the opened project to the vault using the Check In or Check In Folder command.
- 6 Use the Open from Vault or Check Out command to open and check out the file from the vault.
- 7 To work on more files in the project, check out multiple files to the working folder using the Check Out All command in the Project Manager.
- 8 When you finish modifying the files, check them back into the vault using the Check In All command in the Project Manager. All related files update.

### **Best practices for vault commands**

Below are the suggested workflows for using the most common vault commands with AutoCAD Electrical.

#### **Open from vault**

Use Open from the Vault to access files in the vault for viewing or editing. To modify a file from the vault, the file must be checked out to you and worked on from your local drive. You must be logged into the Autodesk Data Management Server to open and check out a file.

- 1 In the Project Manager, select Open Project from Vault from the project selection menu.
- 2 In the Select file dialog box, navigate to the project definition file, and then select it. To maintain the relationship between the drawing files that are defined in the project file, you must check out all files specified in a project file when opening a project from Vault.
- 3 Click Open.

#### **Get latest version**

Get Latest Version retrieves a read-only copy of the most recent design data that is checked in. You cannot modify it until you check it out using Autodesk Vault Explorer or the Vault add-in for AutoCAD-based products.

- 1 In the Project Manager, select a file.
- 2 Right-click and select:
  - Get Latest Version to get the most recent version of the selected project file.
  - Get Latest Version for All to get the most recent version of the selected project file and all of the related files.
- 3 In the Get Latest Version dialog box, click OK.

The most recent versions of the selected files are downloaded from the vault. If the working copy of a file is newer than the most recent version of the file in the vault, you are prompted to choose either losing changes made to the current working copy or to not get the latest version of that file.
- 4 Click Settings to get the parents and children of the selected file.

#### **Get previous version**

Get Previous Version retrieves a past version of a file or a project and places a read-only copy in your working folder. Historical versions can never be modified. You can only create a new version of a file.

- 1 In the Project Manager, right-click a file or project, and then click Get Previous Version.
- 2 In the Get Previous Version dialog box, select a version of the file or project to retrieve.
- 3 If the file has parents and children to get, click Settings, and then specify which related files are retrieved as well.
- 4 Click OK.

A read-only copy of the file is placed in the local working folder. You can view the file but you cannot modify it. To modify the file, you must check it out.

#### **Create a project version**

Project versions are controlled by project file (.wdp) versions. The project file acts as the parent for all drawings in the project and each version of the .wdp

is associated to the latest versions of the drawing at that instance. You can edit individual drawings of a project and create versions of the drawings as needed. When you want to take a project snapshot (create a project version), check out the .wdp and check it back in.

Even if the .wdp is not modified, if any drawings have newer versions, a newer version of the .wdp is created, associating all newer drawing versions.

---

**TIP** Use Vault Explorer to examine the relationship between versions of the project file and corresponding drawings.

---

### **Roll back to a previous project version**

You can roll back to a previous project version using Vault Explorer, restoring the project file (.wdp) and all associated drawing and project configuration files to a previous version.

- 1 Close the project and drawings in AutoCAD Electrical.
- 2 Using Vault Explorer, examine the .wdp file and corresponding drawing versions.
- 3 Select the desired .wdp file.
- 4 Click Get Previous Version.

### **Automatically check in drawings**

Some operations in AutoCAD Electrical (such as project-wide or reporting tools) cause Vault to automatically check out all affected drawings. These drawings can be automatically checked in when modifications are complete. When asked whether to check the file in, click Yes or Yes to All. If you do not want to be prompted to check in your drawings since you want the check-in to happen automatically, in the Options dialog box, select Check In dialog on auto check in.

When files are checked in, comments are automatically added to help identify and distinguish between the versions of the files that are automatically created. You can modify the comments as desired during check-in unless you suppressed the Check In dialog box.

### **Shared sandbox guidelines**

A shared workspace is a working folder located on a shared server for all users to access. The shared workspace configuration can be used with:

- Autodesk Vault



- Autodesk Vault Explorer
- AutoCAD Vault Add-in
- Microsoft Vault Add-in

You can choose to work in a local or shared working folder according to your design requirements. A shared working folder is highly recommended for the AutoCAD Electrical environment, especially in a multi-user situation, because it enables you and your design team to keep all files up-to-date.

To use a shared workspace, the system administrator should preset a consistent working folder for all project members to use. Assign the working folder location to the root level (\$) of the vault. A shared working folder cannot be assigned to a subfolder.

---

**NOTE** If Inventor add-in clients will access the same vault, do not enforce a shared working folder. If Inventor and AutoCAD Electrical are sharing the same vault, the vault administrator cannot enforce the shared working folder. Each AutoCAD Electrical user must set the working folder individually to point to a common network drive.

---

### **Rules For Using Shared Working Folders**

Using a shared workspace means multiple users may be working on the same files. All your vault operations are protected as long as you log into the vault before working on the files. The following guidelines will help prevent you from overwriting the changes made by someone else, and vice versa.

- 1 Remain logged into the vault at all times. You can use the Vault auto login option so you are automatically logged into the vault when AutoCAD Electrical starts.
- 2 If a file is currently checked out to another user, you cannot perform the following operations:
  - Get Latest Version
  - Get Previous Version
  - Check Out
- 3 You cannot check out a file that is currently opened for read-write by another user.
- 4 You can still check out a file that is opened for read only by another user.

- 5 You can open a file in read only when it is currently checked out to someone else using the same working folder.
- 6 Ensure that the drawings are checked back into the vault after you finish working on them so they are available to other users who need to modify them.

# AutoCAD Electrical Command

# 25

## AutoCAD Electrical Commands

### Commands

These topics are called from within the command itself. If you do not find all the information you need, look further in the Help.

[3 Phase Wire Numbers](#) on page 975

[Add Attribute](#) on page 875

[Add Connector Pins](#) on page 1147

[Add/Edit Internal Jumper](#) on page 856

[Add/Edit Power Source/Load Levels](#) on page 1668

[Add Geometry](#) on page 1659

[Add Rung](#) on page 965

[Add Table to Catalog Database](#) on page 1298

[Add Wire Connections](#) on page 1660

[Adjust In-Line Wire/Label Gaps](#) on page 1000

[Align](#) on page 800

[Associate Terminals](#) on page 1055

[Autodesk Inventor Professional Export](#) on page 1521

[Automatic Report Selection](#) on page 1497  
[Bend Wire](#) on page 921  
[Block Replacement](#) on page 1664  
[Break Apart Terminal Associations](#) on page 1057  
[Cable Markers](#) on page 934  
[Change Attribute Justification](#) on page 870  
[Change Attribute Layer](#) on page 862  
[Change Attribute Size](#) on page 873  
[Change/Convert Wire Type](#) on page 275  
[Change Cross-reference to Multiple Line Text](#) on page 879  
[Check/Repair Gap Pointers](#) on page 1688  
[Check/Trace Wire](#) on page 1688  
[Child Location/Description Update](#) on page 882  
[Circuit Builder](#) on page 706  
[Clean Drawing Utility](#) on page 1687  
[Component Cross-reference](#) on page 810  
[Conduit Marker \(From/To List\)](#) on page 1627  
[Conduit Marker \(Pick\)](#) on page 1627  
[Conduit Marker Report](#) on page 1634  
[Continue Surfer](#) on page 1187  
[Convert Block to Destination Arrow](#) on page 1646  
[Convert Block to Source Arrow](#) on page 1646  
[Convert Ladder](#) on page 966  
[Convert Text to Attribute Definition](#) on page 1645  
[Convert Text to Wire Number](#) on page 1645  
[Convert to Schematic Component](#) on page 1642  
[Copy/Add Component Override](#) on page 817

[Copy Assembly](#) on page 1564  
[Copy Catalog Assignment](#) on page 1299  
[Copy Circuit](#) on page 724  
[Copy Component](#) on page 773  
[Copy Footprint](#) on page 1561  
[Copy Installation Code](#) on page 1582  
[Copy Group Code](#) on page 1582  
[Copy Level Assignments](#) on page 1613  
[Copy Location Code](#) on page 1582  
[Copy Mount Code](#) on page 1582  
[Copy Project](#) on page 156  
[Copy Terminal Block Properties](#) on page 1057  
[Copy Wire Number](#) on page 999  
[Copy Wire Number \(In-Line\)](#) on page 1000  
[Create/Edit Wire Type](#) on page 266  
[Create New Drawing](#) on page 168  
[Create New Project](#) on page 154  
[Create a project-specific catalog database](#) on page 1279  
[Cross-reference Check](#) on page 813  
[Delete Component](#) on page 798  
[Delete Connector Pins](#) on page 1148  
[Delete Footprint](#) on page 798  
[Delete Project](#) on page 189  
[Delete Wire Gap](#) on page 956  
[Delete Wire Numbers](#) on page 1008  
[Destination Signal Arrow](#) on page 1012  
[Drawing Audit](#) on page 1692

[Drawing Properties: Components](#) on page 222  
[Drawing Properties: Cross-references](#) on page 228  
[Drawing Properties: Drawing Format](#) on page 231  
[Drawing Properties: Drawing Settings](#) on page 220  
[Drawing Properties: Styles](#) on page 1016  
[Drawing Properties: Wire Numbers](#) on page 979  
[Edit Component](#) on page 742  
[Edit Conduit Marker](#) on page 1627  
[Edit Footprint](#) on page 1565  
[Edit Jumper](#) on page 1122  
[Edit Language Database File](#) on page 1203  
[Edit Selected Attribute](#) on page 861  
[Edit Wire Number](#) on page 992  
[Edit Wire Sequence](#) on page 1034  
[Edit User Table Data](#) on page 854  
[Electrical Audit](#) on page 1689  
[Electrical Standards Database Editor](#) on page 685  
[Export to Spreadsheet](#) on page 1500  
[Fan In/Out Destination](#) on page 1024  
[Fan In/Out - Single Line Layer](#) on page 1025  
[Fan In/Out Source](#) on page 1023  
[Find/Edit/Replace Component Text](#) on page 865  
[Find/Replace Terminal Text](#) on page 866  
[Find/Replace Wire Numbers](#) on page 986  
[Fix Wire Numbers](#) on page 990  
[Fix/UnFix Component Tag](#) on page 877  
[Flip Wire Gap](#) on page 956

[Flip Wire Number](#) on page 1002

[Footprint Database File Editor](#) on page 1595

[Hide Attribute \(Single Picks\)](#) on page 868

[Hide Attribute \(Window/Multiple\)](#) on page 868

[Hide/Unhide Cross-Referencing](#) on page 812

[Hide Wire Numbers](#) on page 1008

[Icon Menu Wizard](#) on page 1234

[IEC Tag Mode - Update](#) on page 192

[In-Line Wire Labels](#) on page 924

[Insert 22.5 Degree Wire](#) on page 912

[Insert 45 Degree Wire](#) on page 912

[Insert 67.5 Degree Wire](#) on page 912

[Insert Balloon](#) on page 1601

[Insert Component](#) on page 737

[Insert Component \(Catalog List\)](#) on page 776

[Insert Component \(Equipment List\)](#) on page 785

[Insert Component \(Panel List\)](#) on page 790

[Insert Connector](#) on page 1152

[Insert Connector from List](#) on page 1177

[Insert Angled Tee Markers](#) on page 1032

[Insert Dot Tee Markers](#) on page 1031

[Insert/Edit Boundary Box Assignment](#) on page 1619

[Insert/Edit Panel Level Assignment \(for components\)](#) on page 1620

[Insert/Edit Panel Level Assignment \(for terminal strips\)](#) on page 1615

[Insert Footprint \(Catalog List\)](#) on page 1555

[Insert Footprint \(Equipment List\)](#) on page 1559

[Insert Footprint \(Icon Menu\)](#) on page 1548

[Insert Footprint \(Manual\)](#) on page 1552  
[Insert Footprint \(Manufacturer Menu\)](#) on page 1544  
[Insert Footprint \(Schematic List\)](#) on page 1537  
[Insert Hydraulic Components](#) on page 1676  
[Insert Ladder](#) on page 961  
[Insert Panel Assembly](#) on page 1563  
[Insert P&ID Components](#) on page 1681  
[Insert PLC \(Full Units\)](#) on page 592  
[Insert PLC \(Parametric\)](#) on page 588  
[Insert Pneumatic Components](#) on page 1671  
[Insert Reference Arrow - From](#) on page 847  
[Insert Reference Arrow - To](#) on page 846  
[Insert Saved Circuit](#) on page 735  
[Insert Splice](#) on page 1184  
[Insert Stand Alone Cross-reference](#) on page 843  
[Insert Terminal \(Manual\)](#) on page 1552  
[Insert Terminal \(Panel List\)](#) on page 794  
[Insert Terminal \(Schematic List\)](#) on page 1538  
[Insert Terminal Strip Representation](#) on page 1614  
[Insert WBlocked Circuit](#) on page 735  
[Insert Wire](#) on page 912  
[Insert Wire Gap](#) on page 956  
[Insert Wire Numbers](#) on page 971  
[Interconnect Components](#) on page 918  
[Language Conversion](#) on page 1202  
[Link Catalog Number](#) on page 1657  
[Link Components with Dashed Lines](#) on page 845



[Link Description](#) on page 1657  
[Link Item Number](#) on page 1657  
[Link Installation Code](#) on page 1657  
[Link Location Code](#) on page 1657  
[Link Manufacturer](#) on page 1657  
[Link PLC Address Description](#) on page 1657  
[Link Rating](#) on page 1657  
[Link Split Tag](#) on page 1657  
[Link Terminal Number](#) on page 1657  
[Link User](#) on page 1657  
[List Signal Code](#) on page 848  
[Location Box](#) on page 889  
[Location Symbols](#) on page 885  
[Make Xdata Visible](#) on page 1526  
[Map Attributes from Old to New](#) on page 1642  
[Mark/Verify Drawings](#) on page 1200  
[Mark Component to Pass Power](#) on page 1669  
[Migration Utility](#) on page 132  
[Missing Level/Sequence Assignments](#) on page 1435  
[Modify Symbol Library](#) on page 893  
[Move Circuit](#) on page 725  
[Move Component](#) on page 800  
[Move Connector Pins](#) on page 1150  
[Move/Show Attribute](#) on page 868  
[Move Wire Number](#) on page 996  
[Multiple Cable Markers](#) on page 949  
[Multiple Insert \(Icon Menu\)](#) on page 738

[Multiple Insert \(Pick Master\)](#) on page 775

[Multiple Wire Bus](#) on page 917

[Next Project Drawing](#) on page 1189

[Panel Bill of Materials Report](#) on page 1430

[Panel Component Report](#) on page 1433

[Panel Component Exception Report](#) on page 1432

[Panel Configuration](#) on page 1527

[Panel Nameplate Report](#) on page 1437

[Panel Terminal Exception Report](#) on page 1439

[Panel Terminal Strip Report](#) on page 1622

[Panel Terminal Strip Swap Wire Text](#) on page 1611

[Panel Wire Connection Report](#) on page 1440

[Pin List Database Editor](#) on page 1307

[PLC Database File Editor](#) on page 603

[PLC Database Migration Utility](#) on page 617

[PLC I/O Wire Numbers](#) on page 976

[Power Load Check Report](#) on page 1670

[Previous Project Drawing](#) on page 1189

[Project Manager](#) on page 145

[Project Properties: Components](#) on page 207

[Project Properties: Cross-references](#) on page 215

[Project Properties: Drawing Format](#) on page 218

[Project Properties: Project Settings](#) on page 204

[Project Properties: Styles](#) on page 216

[Project Properties: Wire Numbers](#) on page 211

[Project-Wide Utilities](#) on page 904

[Project-Wide Update/Retag](#) on page 1196

[Promise Conversion](#) on page 1639

[Publish to Web](#) on page 1205

[Push Description Down](#) on page 867

[Push Description Up](#) on page 867

[Rebuild/Freshen Project Database](#) on page 195

[Recalculate Wire Size](#) on page 720

[Remove Component Override](#) on page 818

[Remove Level/Sequencing Assignment](#) on page 1610

[Rename Attribute](#) on page 874

[Rename Panel Layers](#) on page 261

[Rename Schematic Layers](#) on page 261

[Renumber Ladder Reference](#) on page 1196

[Report Format File Setup - Missing Level/Sequence Assignments](#) on page 1451

[Report Format File Setup - Panel Bill of Material](#) on page 1444

[Report Format File Setup - Panel Component](#) on page 1448

[Report Format File Setup - Panel Component Exception](#) on page 1446

[Report Format File Setup - Panel Nameplate](#) on page 1454

[Report Format File Setup - Panel Terminal Exception](#) on page 1456

[Report Format File Setup - Panel Wire Connection](#) on page 1458

[Report Format File Setup - Schematic Bill of Material](#) on page 1461

[Report Format File Setup - Schematic Cable From/To](#) on page 1463

[Report Format File Setup - Schematic Cable Summary](#) on page 1465

[Report Format File Setup - Schematic Component](#) on page 1478

[Report Format File Setup - Schematic Component Wire List](#) on page 1469

[Report Format File Setup - Schematic Connector Details](#) on page 1471

[Report Format File Setup - Schematic Connector Plug](#) on page 1474

[Report Format File Setup - Schematic Connector Summary](#) on page 1476

[Report Format File Setup - Schematic Missing Bill of Material](#) on page 1480

[Report Format File Setup - Schematic PLC/IO Address and Descriptions](#) on page 1484

[Report Format File Setup - Schematic PLC I/O Component Connection](#) on page 1467

[Report Format File Setup - Schematic PLC Modules Used So Far](#) on page 1491

[Report Format File Setup - Schematic Terminal Numbers](#) on page 1486

[Report Format File Setup - Schematic Terminal Plan](#) on page 1489

[Report Format File Setup - Schematic Wire From/To](#) on page 1483

[Report Format File Setup - Schematic Wire Label](#) on page 1493

[Report Format File Setup - Wire Annotation Exception](#) on page 1452

[Resequenece Item Numbers](#) on page 1604

[Retag Components](#) on page 878

[Reverse Connector](#) on page 1143

[Reverse/Flip Component](#) on page 805

[Revise Ladder](#) on page 966

[Rotate Attribute](#) on page 869

[Rotate Connector](#) on page 1142

[RSLogix 500 Export to Spreadsheet](#) on page 640

[Save Circuit to Icon Menu](#) on page 733

[Schematic Bill of Material Report](#) on page 1403

[Schematic Cable From/to Report](#) on page 1407

[Schematic Cable Summary Report](#) on page 1405

[Schematic Component Report](#) on page 1415

[Schematic Component Wire List Report](#) on page 1409

[Schematic Connector Details Report](#) on page 1410

[Schematic Connector Plug Report](#) on page 1412

[Schematic Connector Summary Report](#) on page 1413  
[Schematic Database File Editor](#) on page 782  
[Schematic Missing Bill of Material Report](#) on page 1416  
[Schematic PLC I/O Address and Descriptions Report](#) on page 1419  
[Schematic PLC I/O Component Connection Report](#) on page 1407  
[Schematic PLC Modules Used So Far Report](#) on page 1422  
[Schematic Terminal Numbers Report](#) on page 1420  
[Schematic Terminal Plan Report](#) on page 1421  
[Schematic Wire From/To Report](#) on page 1418  
[Schematic Wire Label Report](#) on page 1423  
[Scoot](#) on page 799  
[Set Wire Type](#) on page 277  
[Settings Compare](#) on page 240  
[Show Footprint Sequencing Assignments](#) on page 1611  
[Show Links](#) on page 1660  
[Show Missing Catalog Assignments](#) on page 1303  
[Show Signal Paths](#) on page 849  
[Show Terminal Associations](#) on page 1057  
[Show Terminal Strip Sequencing Assignments](#) on page 1611  
[Show Wire Sequence](#) on page 1029  
[Show Wires](#) on page 977  
[Signal Error/List Report](#) on page 1018  
[Source Signal Arrow](#) on page 1014  
[Special Explode](#) on page 1653  
[Split PLC Module](#) on page 802  
[Split Connector](#) on page 802  
[Spreadsheet to PLC I/O Utility](#) on page 631

[Squeeze Attribute/Text](#) on page 871  
[Stretch Attribute/Text](#) on page 871  
[Stretch Connector](#) on page 1144  
[Stretch PLC Module](#) on page 801  
[Stretch Wire](#) on page 920  
[Surfer](#) on page 1187  
[Swap/Update Block](#) on page 333  
[Swap Connector Pins](#) on page 1149  
[Swap Wire Numbers](#) on page 999  
[Symbol Builder](#) on page 342  
[Tag Child](#) on page 1654  
[Tag Child - Form C](#) on page 1654  
[Tag Child - N.C.](#) on page 1654  
[Tag Child - N.O.](#) on page 1654  
[Tag Nameplate](#) on page 1656  
[Tag Panel Component](#) on page 1656  
[Tag Panel Terminal - Terminal Number](#) on page 1656  
[Tag Panel Terminal - Wire Number](#) on page 1656  
[Tag PLC](#) on page 1654  
[Tag Schematic Component](#) on page 1654  
[Tag Schematic Terminal - Terminal Number](#) on page 1654  
[Tag Schematic Terminal - Wire Number](#) on page 1654  
[Tag Schematic Terminal - Wire Number Change](#) on page 1654  
[Terminal: Erase Internal/External Connections](#) on page 1130  
[Terminal: Mark External Connections](#) on page 1130  
[Terminal: Mark Internal Connections](#) on page 1130  
[Terminal: Show Internal/External Connections](#) on page 1130

[Terminal List \(From File\)](#) on page 1127

[Terminal List \(Manual Picks\)](#) on page 1127

[Terminal Properties Database Editor](#) on page 1060

[Terminal Renumber \(Pick Mode\)](#) on page 1132

[Terminal Renumber \(Project-Wide\)](#) on page 1133

[Terminal Strip Editor](#) on page 1071

[Terminal Strip Table Generator](#) on page 1116

[Title Block Setup](#) on page 1213

[Title Block Update](#) on page 1221

[Toggle Angled Tee Markers](#) on page 1033

[Toggle NO/NC](#) on page 808

[Toggle Wire Number In-Line](#) on page 978

[Trim Wire](#) on page 919

[Unlink](#) on page 1661

[Unhide Attribute \(Window/Multiple\)](#) on page 869

[Unhide Wire Numbers](#) on page 1008

[Unity Pro Export](#) on page 652

[Unity Pro Export to Spreadsheet](#) on page 646

[Update from Project Scratch Database](#) on page 194

[Update from Spreadsheet](#) on page 1507

[Update Signal References](#) on page 844

[Update Stand-alone Cross-reference](#) on page 844

[Update Symbol Library WD\\_M Block](#) on page 255

[Update to New WD\\_M Block, No Changes](#) on page 254

[Update to New WD\\_M Block, Values, Layers](#) on page 254

[Update to New WD\\_PNLM Block, No Changes](#) on page 254

[Update to New WD\\_PNLM Block, Values, Layers](#) on page 254

[User Defined Attribute List](#) on page 1510  
[View/Edit Component Sequence](#) on page 1612  
[Wire Annotation Exception Report](#) on page 1436  
[Wire Annotation of Panel Footprint](#) on page 1588  
[Wire Arrows for Reference Only](#) on page 738  
[Wire Color/Gauge Labels](#) on page 923  
[Wire/Conduit Routing Report](#) on page 1635  
[Wire Number Leader](#) on page 997  
[Xdata Editor](#) on page 1695  
[X-Y Grid Setup](#) on page 234  
[X Zones Setup](#) on page 233  
[Zip Project](#) on page 188



# Index

\_LISTBOX\_DEF table 1279, 1291  
\_PINLIST database table 1309  
@MOTOR\_NUM@ (motor symbol tags) 2059, 2061

1 pole circuit breaker symbols 454  
1-line circuits 27, 700, 703, 706  
1-line symbols 329  
1-phase ladders 963  
1-phase motor symbols 487  
2+ pole circuit breaker symbols 458  
3-phase ladders 963  
3 Phase Wire Numbering dialog box 976  
3-phase buses 975  
3-phase motor symbols 489, 655, 2006  
3-phase transformer symbols 473  
3-phase wires 917–918, 976  
3-position selector switches 450  
3-voltage-phase switch symbols 545  
3D designs 1519  
4-position selector switch symbols 452

## A

A plug switch symbols 415  
Access databases  
    cable conductor database 954  
    PLC database format 630  
accessories 1104  
ace\_electrical\_standards.mdb file 681, 711  
ace\_plc.mdb file 2005  
active power indicator symbols 551  
Add Attribute dialog box 876  
Add Catalog Record dialog box 1298  
Add Existing Circuit dialog box 1247  
Add Footprint Record dialog box 1599  
add geometry 1941  
Add Geometry tool 1660  
Add Icon - Command dialog box 1242  
Add Icon - Component dialog box 1239

Add New Table to MDB dialog box 1299  
Add Record dialog box 780  
Add Spare Wires dialog box 1632  
add-on jumpers 1122–1123  
Add/Modify Associations dialog box 1050

## addresses

    exporting data 1505  
    I/O component reports 1420, 1486  
    PLC database information 601  
    PLC I/O points 624  
    PLC modules 596  
ae\_electrical\_standards.mdb files 712  
AE2LADDER command 968  
AE3PHASEWIRENO command 976  
AEADDCATALOGTABLE command 1299  
AEAIPEXPORT command 1522  
AEATTJUSTIFY command 871  
AEATTLAYER command 863  
AEATTRIBUTE command 876  
AEATTSIZE command 874  
AEAUDIT command 1692  
AEAUDITDWG command 1694  
AEAUTOREPORT command 1499  
AEBLK2SCH command 1644  
AEBLOCKREPLACE dialog box 1665  
AEBOUNDARYBOX command 1620  
AEC\_CIRCS sheet 2039  
AECABLEMARKER command 939, 943, 945, 947  
AECCHILDLOCUPDATE command 883  
AECIRCBUILDER command  
    Circuit Configuration dialog box 710  
    Circuit Selection dialog box 708  
    Select Motor dialog box 711  
AECOMPONENT command  
    Add Record dialog box 1298  
    Component Annotation from External File dialog box 760  
    Component Catalog Lookup dialog box 1294

Edit Entry dialog box 1138  
 Edit Multi-Connection Sequence  
     Terminal Symbol dialog  
     box 1135  
 Edit PLC I/O Point dialog box 624  
 Edit Record dialog box 1298  
 Insert Component dialog box 742  
 Insert/Edit Child Component - IEC  
     dialog box 773  
 Insert/Edit Child Component dialog  
     box 769  
 Insert/Edit Component dialog  
     box 748, 753  
 Insert/Edit Terminal Symbol dialog  
     box 1046  
 Option - Tag Format Family Override  
     dialog box 759  
 Panel Tag List dialog box 758  
 Parts Catalog dialog box 1291  
 Tags in Use dialog box 757  
 AECOMPOENTCAT command 778,  
     780  
 AECOMPONENTPNL command 791,  
     794  
 AECOMPONENTQ command 787, 789  
 AECONDUITMARKER command 1631–  
     1632  
 AECONDUITMARKERLIST  
     command 1631  
 AECONDUITMARKERRPT  
     command 1332, 1635  
 AECONNECTOR command 1157, 1159  
 AECONNECTORLIST command 1174  
 AECONVERTWIRETYPE command 277  
 AECOPY2SYMLIB command 255  
 AECOPYGROUPCODE command 1584  
 AECOPYINSTcommand 1584  
 AECOPYLEVEL command 1614  
 AECOPYLOC command 1584  
 AECOPYMOUNTCODE command 1584  
 AECOPYOVERRIDE command 818  
 AEDESTINATION command 1014  
 AEDWGCFG command 241, 243–244  
 AEECDS2ACADEDWG command 1650  
 AEEDITATT command 861  
 AEEDITCOMPONENT command  
     Add Record dialog box 1298  
     Add/Modify Associations dialog  
     box 1050  
     Component Annotation from External  
     File dialog box 760  
     Connector Pin Numbers in Use dialog  
     box 1161  
     Edit Record dialog box 1298  
     Insert/Edit Child Component dialog  
     box 769, 773  
     Insert/Edit Component dialog  
     box 748, 753  
     Insert/Edit Terminal Symbol dialog  
     box 1046  
     Option - Tag Format Family Override  
     dialog box 759  
     Panel Tag List dialog box 758  
     Parts Catalog dialog box 1291  
     Pin Numbers in Use dialog box 764  
     Ratings Defaults dialog box 808  
     Select Description for AutoCAD  
     Electrical Language Table  
     dialog box 762  
     Select Description Text Format dialog  
     box 763  
     Tags in Use dialog box 757  
     Terminal Block Properties dialog  
     box 1053  
 AEEDITCONDUITMARKER  
     command 1631  
 AEEDITFOOTPRINT command 1569  
 AEEDITWIRENO command 994  
 AEEDITWIRESEQUENCE  
     command 1037  
 AEEXPLODE command 1654  
 AEEXPORT2SS command  
     Component Data Export dialog  
     box 1502  
     Export to Spreadsheet dialog  
     box 1501  
     General Data Export dialog  
     box 1503  
     Panel Layout Data Export dialog  
     box 1506

Panel Terminals Data Export dialog  
     box 1506  
 PLC I/O Address/Description Export  
     dialog box 1505  
 PLC I/O Connection Export dialog  
     box 1504  
 PLC I/O Header Information Export  
     dialog box 1503  
 Terminal Data Export dialog  
     box 1507  
 Update Drawings per Spreadsheet  
     Data dialog box 1508  
 AEFANIN command 1026  
 AEFANINDEST command 1025  
 AEFANINSRC command 1024  
 AEFINDCOMPTEXT command 865–866  
 AEFINDTERMTEXT command 867  
 AEFINDWIRENO command 987  
 AEFIXTAG command 878  
 AEFLIP command 805  
 AEFOOTPRINT command  
     Component Catalog Lookup dialog  
         box 1294  
     Din Rails dialog box 853  
     Footprint dialog box 1555  
     Insert Footprint dialog box 1551  
     Panel Layout - Component Insert/Edit  
         dialog box 1569  
 AEFOOTPRINTCAT command 1557  
 AEFOOTPRINTDB command 1596, 1599  
 AEFOOTPRINTEQ command 1559  
 AEFOOTPRINTMAN command 1555  
 AEFOOTPRINTMFG command 1545,  
     1547  
 AEFOOTPRINTQ command 787  
 AEFOOTPRINTSCH command 1538,  
     1542  
 AEFORMATFILE command  
     Report Format File Setup - Missing  
         Level/Sequence Assignments  
         dialog box 1452  
     Report Format File Setup - Panel Bill  
         of Materials dialog  
         box 1446  
 Report Format File Setup - Panel  
     Component dialog  
     box 1451  
 Report Format File Setup - Panel  
     Component Exception dialog  
     box 1448  
 Report Format File Setup - Panel  
     Nameplate dialog box 1456  
 Report Format File Setup - Panel  
     Terminal Exception dialog  
     box 1458  
 Report Format File Setup - Panel Wire  
     Connection dialog  
     box 1461  
 Report Format File Setup - Schematic  
     Bill of Material dialog  
     box 1463  
 Report Format File Setup - Schematic  
     Cable From/To dialog  
     box 1465  
 Report Format File Setup - Schematic  
     Cable Summary dialog  
     box 1467  
 Report Format File Setup - Schematic  
     Component dialog  
     box 1480  
 Report Format File Setup - Schematic  
     Component Wire List dialog  
     box 1471  
 Report Format File Setup - Schematic  
     Connector Details dialog  
     box 1474  
 Report Format File Setup - Schematic  
     Connector Plug dialog  
     box 1476  
 Report Format File Setup - Schematic  
     Connector Summary dialog  
     box 1478  
 Report Format File Setup - Schematic  
     Missing Bill of Material  
     dialog box 1483  
 Report Format File Setup - Schematic  
     PLC I/O Address and  
     Descriptions dialog  
     box 1486

Report Format File Setup - Schematic  
     PLC I/O Component  
     Connection dialog  
     box 1469  
 Report Format File Setup - Schematic  
     PLC Modules Used So Far  
     dialog box 1493  
 Report Format File Setup - Schematic  
     Terminal Numbers dialog  
     box 1489  
 Report Format File Setup - Schematic  
     Terminal Plan dialog  
     box 1491  
 Report Format File Setup - Schematic  
     Wire From/To dialog  
     box 1484  
 Report Format File Setup - Schematic  
     Wire Label dialog box 1495  
 Report Format File Setup - Wire  
     Annotation Exception dialog  
     box 1454  
 AEGEOMETRY command 1660  
 AEIMPORTDB command 195  
 AEINTERNALJUMPER command 857  
 AEJUMPER command 1125, 1127  
 AELADDER command 963  
 AELANG command 1203  
 AELANGDB command 1204  
 AELISTSIG command 849  
 AELOCATIONSYMBOL command 887  
 AEMAPATT command 1644  
 AEMARKVERIFY command 1202  
 AEMENUWIZ command  
     Add Existing Circuit dialog  
     box 1247  
     Add Icon - Command dialog  
     box 1242  
     Add Icon - Component dialog  
     box 1239  
     Create Circuit dialog box 1244  
     Create New Submenu dialog  
     box 1249  
     Icon Menu Wizard dialog box 1237  
     Properties - Circuit dialog box 1257  
     Properties - Command dialog  
     box 1254  
     Properties - Component dialog  
     box 1252  
     Properties - Main Menu dialog  
     box 1250  
     Properties - Submenu dialog  
     box 1259  
 AEMIGRATION command  
     Migration Review dialog box 136  
     Migration Utility dialog box 134  
 AEMTEXT2ATT command 1645  
 AEMULTI command  
     Insert Component dialog box 742  
     Insert/Edit Child Component dialog  
     box 769, 773  
 AEMULTIBUS command 918  
 AEMULTICABLE command 949, 953,  
     1338  
 AEP2E command 1639, 1641  
 AEPANELCONFIG command 264  
     Format - Schematic Layout Wire  
     Connection Annotation  
     dialog box 1531  
     Panel Balloon Setup dialog  
     box 1602  
     Panel Drawing Configuration and  
     Defaults dialog box 1529  
 AEPANELLEVEL command 1619, 1622  
 AEPANELREPORT command  
     generating reports 1330  
     Missing Level/Sequence Assignments  
     dialog box 1436  
     Panel Bill of Material Data Fields to  
     Report dialog box 1340  
     Panel Bill of Materials dialog  
     box 1432  
     Panel Component Data Fields to  
     Report dialog box 1344  
     Panel Component dialog box 1435  
     Panel Component Exception Data  
     Fields to Report dialog  
     box 1342  
     Panel Component Exception dialog  
     box 1433  
     Panel Missing Level/Sequence  
     Assignments Data Fields to  
     Report dialog box 1346

Panel Nameplate Data Fields to Report dialog box 1350  
 Panel Nameplate dialog box 1439  
 Panel Terminal Exception Data Fields to Report dialog box 1352  
 Panel Terminal Exception dialog box 1440  
 Panel Wire Annotation Exception Data Fields to Report dialog box 1348  
 Panel Wire Connection Data Fields to Report dialog box 1354  
 Panel Wire Connection dialog box 1441  
 Wire Annotation Exception dialog box 1437  
 AEPANELTERMINAL command 1574  
 AEPANELTERMINALSCH command 1540, 1542  
 AEPASSPWR command 1670  
 AEPINLISTTABLE command 1307, 1309, 1311  
 AEPLC command 596  
 AEPLCDB command  
   Module Box Dimensions dialog box 608  
   Module Specifications dialog box 616  
   New Module dialog box 611  
   PLC Database File Editor 606  
   PLC Selection dialog box 607  
   Prompts at Module Insertion Time dialog box 617  
   Select Terminal Information dialog box 610  
   Style Box Dimensions dialog box 614  
   Terminal Block Settings dialog box 613  
 AEPLCP command  
   Module Layout dialog box 591  
   PLC Parametric Selection dialog box 590  
 AEPLCWIRENO command 977  
 AEPOWERLOADLEVELS command 1669  
 AEPOWERLOADREPORT command 1670  
 AEPROJECT command  
   about 154  
   Batch Plotting Options and Order dialog box 1193  
   Copy Project dialog box 156  
   Create New Drawing dialog box 171  
   Create New Project dialog box 156  
   Cross-Reference Table Data Fields to Display dialog box 1397  
   Drawing List Data Fields to Display dialog box 1334  
   Drawing List Display Configuration dialog box 174  
   Drawing List Report dialog box 192  
   Edit Cross-Reference Symbol Mapping dialog box 832  
   Graphical Cross-Reference Format Setup dialog box 824  
   Properties dialog box 206  
   Select Drawings to Process dialog box 196  
   Table Cross-Reference Format Setup dialog box 830  
   Task List dialog box 194  
   Update Title Block dialog box 1224  
   Wire Numbers tab 986  
 AEPROJUPDATE command 1199  
 AEPROPERTIES command  
   codes for replaceable parameters 239  
   Define Layers dialog box 261  
   Drawing Settings dialog box 222  
   Edit Cross-Reference Symbol Mapping dialog box 832  
   Wire Numbers tab 982  
 AEPUBLISH2WEB command 1206–1207  
 AEREBUILDDDB command 196  
 AERENAMELAYER command 262  
 AERENAMEPANELLAYER command 262  
 AERENUMBERLADDER command 969  
 AERESEQUENCE command 1605  
 AERETAG command 879  
 AEREVISELADDER command 968  
 AERMOVERRIDE command 819

AEROUTINGREPORT command  
     Wire Conduit Routing Data Fields to  
         Report dialog box 1396  
     Wire/Conduit Routing Report dialog  
         box 1636  
 AERSLOGIX command 641–642  
 AESAVECIRCUIT command 735  
 AESAVEDCIRCUIT command 736  
 AESAXREF command 844  
 AESCHEMATICDB command 784–785  
 AESCHEMATICREPORT command  
     Bill of Material Data Fields to Report  
         dialog box 1356  
     Cable From/To Data Fields to Report  
         dialog box 1363  
     Cable Label Data Fields to Report  
         dialog box 1364  
     Cable Summary Data Fields to Report  
         dialog box 1358  
     Component Data Fields to Report  
         dialog box 1378  
     Component Wire List Data Fields to  
         Report dialog box 1370  
     Connector Details Data Fields to  
         Report dialog box 1372  
     Connector Plug Data Fields to Report  
         dialog box 1374  
     Connector Summary Data Fields to  
         Report dialog box 1376  
     generating reports 1330  
     Location Code Selection for From/To  
         Reporting dialog box 1427  
     Missing Bill of Material Data Fields to  
         Report dialog box 1380  
     PLC Component Connection Data  
         Fields to Report dialog  
         box 1368  
     PLC I/O Address and Descriptions  
         Data Fields to Report dialog  
         box 1386  
     PLC Modules Used So Far Data Fields  
         to Report dialog box 1390  
     Schematic Bill of Material dialog  
         box 1405  
     Schematic Cable From/To dialog  
         box 1407  
     Schematic Cable Summary dialog  
         box 1407  
     Schematic Component dialog  
         box 1416  
     Schematic Component Wire List  
         dialog box 1410  
     Schematic Connector Details dialog  
         box 1412  
     Schematic Connector Plug dialog  
         box 1413  
     Schematic Connector Summary dialog  
         box 1415  
     Schematic Missing Bill of Material  
         dialog box 1418  
     Schematic PLC I/O Address and  
         Descriptions dialog  
         box 1420  
     Schematic PLC I/O Component  
         Connection dialog  
         box 1409  
     Schematic PLC Modules Used So Far  
         dialog box 1423  
     Schematic Terminal Numbers dialog  
         box 1421  
     Schematic Terminal Plan dialog  
         box 1422  
     Schematic Wire From/To dialog  
         box 1419  
     Schematic Wire Label dialog  
         box 1425  
     Terminal Numbers Data Fields to  
         Report dialog box 1388  
     Terminal Plan Data Fields to Report  
         dialog box 1393  
     Wire From/To Data Fields to Report  
         dialog box 1384  
     Wire Label Data Fields to Report  
         dialog box 1394  
 AESHOWLINK command 1661  
 AESHOWSIG command 849  
 AESHOWXDATA command 1527  
 AESHOWXREFTABLE command 1399  
 AESIGNALERRORREPORT  
     command 1019  
 AESOURCE command 1015  
 AESPLIT command 805

- AESPLITPLC command 805
- AESS2PLC command
  - Spreadsheet to PLC I/O utility 635
  - Spreadsheet to PLC I/O Utility Setup dialog box 639
- AESURF command 1189
- AESWAPBLOCK command 336–338
- AESYMBUILDER command
  - Attribute Editor 349
  - Convert Text to Attribute dialog box 356
  - Insert Wire Connections dialog box 353
  - Insert/Edit Attributes dialog box 350
  - Save Symbol dialog box 359
  - Select SymbolObjects dialog box 344
  - Symbol Audit dialog box 360
  - Symbol Configuration dialog box 345
- AETERMDBEDITOR command 1061–1062, 1064
- AETERMINALPNL command 795–796
- AETERMINALSTRIP command 1615
- AETERMINALSTRIPREPORT command 1623–1624
- AETERMLIST command 1129–1130
- AETERMLISTFROMFILE command 1129–1130
- AETERMRENUM command 1133
- AETRIM command 920
- AETSE command
  - Associate Terminals dialog box 1108
  - Cable Information tab 1087
  - Catalog Code Assignment tab 1083
  - Edit Terminal dialog box 1100
  - Edit/Delete Jumpers dialog box 1109
  - Insert Accessory dialog box 1104
  - Insert Spare Terminal dialog box 1103
  - Layout Preview tab 1093
  - Reassign Terminal dialog box 1101
  - Renumber Terminal Strip dialog box 1102
- Select Row Cell Styles dialog box 1110
- Terminal Strip Definition dialog box 1073
- Terminal Strip Selection dialog box 1072
- Terminal Strip tab 1078
- Terminal Strip Table dialog box 1113
- Toggle Installation Codes dialog box 1106
- Toggle Location Codes dialog box 1105
- AETSEGENERATOR command
  - Terminal Strip Table Generator 1119
  - Terminal Strip Table Settings dialog box 1096
- AEUDA command 1512
- AEUNITYPRO command 652
- AEUNITYPROSS command 651
- AEUNLINK command 1661
- AEUPDATEIECTAG command 193
- AEUPDATESIGREF command 845
- AEUPDATESYMLIB command 893
- AEUSERTABLE command 855
- AEUTILITIES command 1195
- AEVIEWCOMPSEQ command 1613
- AEWBCIRCUIT command 736
- AEWIREANNOTATION command 1590, 1592
- AEWIRECOLORLABEL command 924
- AEWIRECONN command 1660
- AEWIRENO command 972–973, 990
- AEWIRETYPE command 271, 902
- AEXDATA command 1695
- AEXREF command 812
- AEXREFCHECK command 815
- AEXYGRID command 236
- AEXZONE command 234
- AEZIPPROJECT command 188
- Alert dialog box 256
- alignment
  - components 798, 800
  - justified text 870–871
- Allen-Bradley PLCs 640

- alternate environment settings 279
- amp meters 421, 551
- angled tee connections 1029
- angled tee markers 1033–1034
- angled wires 913, 922
- Annotation Presets dialog box 708
- annotations
  - Circuit Builder circuits 681
  - circuits 708
  - converting non-Electrical
    - blocks 1642, 1644
  - cross-reference symbols 839
  - I/O points 622
  - importing from external files 760
  - pins 1313
  - predefined symbol annotations 332
  - presets 708
  - ratings 807–808
  - reports 1428, 1437, 1454
  - schematic wire information 1590, 1592
  - swapping terminal strip text 1612
  - terminal strips 1130
  - wire annotation exceptions 1348
  - wire connections 1531
  - wires 1348, 1437, 1454
- annunciation symbols 581
- archiving projects 187–188
- arrow symbols
  - converting non-Electrical
    - symbols 1647
  - cross-reference arrow symbols 847–848
  - destination signal arrows 1011
  - illustrated 431, 580
  - inserting 1014–1015
  - naming conventions 298
  - project-wide changes 1195
  - source signal arrows 1011
  - styles 1012, 1016, 1018
- assemblies 1563–1565
- ASSEMBLYCODE field 1311
- Assign Wire Numbering Formats by Wire
  - Layers dialog box 990
- assigning
  - catalog information 1283, 1285, 1300
  - level assignments 1614, 1619, 1622
  - missing assignment reports 1436, 1452
  - missing catalog information 1304
  - missing level/sequence
    - assignments 1346, 1436, 1452
  - pins automatically 1984
  - sequencing assignments 1611, 1613
- Associate Terminals dialog box 1108
- associations
  - adding 1055
  - breaking 1057
  - editing 1055
  - terminals 1046, 1050, 1055, 1057, 1078, 1108
- Attribute Editor 349
- attributes
  - adding to non-Electrical
    - entities 1651, 1653, 1656–1657, 1659
  - Attribute Editor 349
  - blocks 875–876
  - child components 320
  - child location codes 882–883
  - circuits 2047–2048, 2066, 2072
  - converting non-Electrical
    - blocks 1642, 1644, 2099
  - converting text to 355–356, 1645
  - converting Xdata to 1527
  - copying codes 1582, 1584
  - COPYTAG attribute 329
  - cross-references 320
  - editing 350, 861, 893
  - fixed component tags 877–878
  - footprint attributes 329, 1526
  - hiding 869
  - hydraulic symbols 329
  - in-line wire labels 320
  - inserting 346, 350
  - justification 870–871
  - ladders 960
  - layers 862–863



- link lines 354
  - link panel descriptions 1943
  - link schematics 1936
  - linking to title blocks 1213
  - location boxes 892
  - location codes 881, 892
  - location mark symbols 885, 887
  - mapping 332, 336, 1663
  - miscellaneous attributes 331
  - missing 360
  - moving 798, 868
  - moving to other layers 862–863
  - multi-line text 880
  - non-AutoCAD Electrical 331
  - P&ID symbols 329
  - parametric build connectors 320
  - parent components 320, 882–883
  - PLC I/O symbols 320
  - predefined annotations 332
  - project-wide changes 1195
  - ratings 807–808
  - renaming 875
  - rotating 870
  - schematic symbols 320
  - splices 320
  - splitting tag names 299
  - TAG1 attribute 321
  - TAG2 attribute 321
  - target attributes for wire
    - information 1587–1588
  - templates 342, 1563, 2107
  - terminal symbols 320, 2005
  - text size 873–874
  - text styles 871
  - title blocks 1213, 1221
  - updating 882–883
  - user-defined 1509–1510, 1512
  - WD\_M blocks 253
  - WDTYPE attribute 329
  - wire connections 320, 351, 353, 1938
    - wire signal symbols 320
  - Xdata 1695
  - auditing
    - drawings 28, 1686, 1688–1689, 1692, 1694
    - symbols 357, 360
  - AutoCAD
    - inserting blocks in PLC
      - modules 611
    - scripts 1195
  - AutoCAD Electrical
    - commands 2148
    - Migration Utility 129–132
    - new features 9, 13, 19, 25
    - online help 3, 6
    - Vault ARX 158
  - AutoCAD Electrical Migration Utility
    - dialog box 134
  - AutoCAD Electrical Publish to Web -
    - Banner, Title Text, Options dialog box 1207
  - Autodesk Inventor Professional
    - exporting data for Cable & Harness 1519, 1521–1522
    - importing data from 1166–1167, 1174
    - spreadsheet structure 1175
  - Autodesk Inventor Professional Export
    - dialog box 1522
  - Autodesk Vault
    - advanced techniques 2134
    - collaborative design and 158
  - AutoLISP
    - circuit attribute assignments 2048
    - mapping values to title blocks 1227
    - running routines 611
  - automatic fill feature 881
  - automatic pin assignments 1984
  - Automatic Report Selection dialog
    - box 1499
  - automatic reports 1496–1497, 1499
  - automatic schematic/panel updates 1532
  - automatic wire numbering 971
- B**
- backing up projects 187–188
  - ball valves 421
  - balloons
    - about 1600
    - inserting 1601–1602

- resequencing item numbers 1604–1605
- banners (web pages) 1207
- batch plotting 1191
- Batch Plotting Options and Order dialog box 1193
- batch report generation 1496
- battery symbols 423, 551, 570
- beacon light symbols 502–503
- bell symbols 423, 570
- bending wires 922
- bi-directional updates 1532
- Bill of Material Data Fields to Report dialog box 1356
- Bill of Materials (BOM)
  - adding part numbers to
    - components 1283, 1285
  - copying 1300
  - equipment lists and 785
  - fields in reports 1340, 1356
  - missing catalog assignments 1304
  - missing data in reports 1380, 1418, 1483
  - multiple catalogs 1303
  - multiple part numbers 755–756, 1303
  - performing checks 1303
  - reports 1402, 1405, 1418, 1432, 1446, 1463, 1483
- Bill of Materials reports
  - about 1402
  - formatting 1446, 1463
  - generating 1405, 1432
- blank lines in reports 1330
- Block Editor 342
- Block Replacement dialog box 1665
- blocks
  - adding geometry to 1660
  - attributes 329, 875–876
  - balloons 1600–1602
  - catalog table data 1271
  - changing symbol appearance 331
  - converting arrow symbols 1647
  - converting non-Electrical blocks 1642, 1644, 2099
  - converting Xdata to attributes 1527
  - creating 339
  - editing library symbols 893
  - exploding 1654
  - footprint attributes 1526
  - footprint lookup files 1594, 1596
  - inserting in PLC modules 611
  - mapping and replacing 1663–1665
  - marker blocks 2037–2038
  - nameplates 1609
  - naming conventions 282, 298
  - PLC terminal blocks 613
  - splitting 798, 802, 805
  - substituting symbols 330
  - swapping 332–333, 336–338
  - Symbol Builder 342
  - terminal blocks 1053, 1065
  - updating 332–333, 336–338
  - user-defined attributes 1509
  - values 875–876
  - WD\_M blocks 253
- BOM (Bill of Materials)
  - adding part numbers to
    - components 1283, 1285
  - copying 1300
  - equipment lists and 785
  - fields in reports 1340, 1356
  - missing catalog assignments 1304
  - missing data in reports 1380, 1418, 1483
  - multiple catalogs 1303
  - multiple part numbers 755–756, 1303
  - performing checks 1303
  - reports 1402, 1405, 1418, 1432, 1446, 1463, 1483
- borders on report tables 1322
- boundary boxes
  - level codes 1620
  - sequences 1620
- branches 1519
- break symbols 1159, 1167
- BREAK value 630
- breakers 454, 458
- breaking
  - connectors 1159, 1167
  - reports into sections 1318, 1330

- terminal associations 1057
- terminal tables 1070
- terminals after modules 610
- bridge rectifier symbols 575
- build direction 2052
- Build of Materials (BOM)
  - adding part numbers to
    - components 1283, 1285
  - equipment lists and 785
  - fields in reports 1340, 1356
  - missing catalog assignments 1304
  - missing data in reports 1380, 1418, 1483
  - multiple catalogs 1303
  - multiple part numbers 755–756, 1303
  - performing checks 1303
  - reports 1402, 1405, 1418, 1432, 1446, 1463, 1483
- bus-tap symbols 298, 304
- buses
  - 3-phase 917–918
  - multiple 1163
  - spacing 918, 2053
- buzzer symbols 423, 570

## C

- Cable & Harness (Inventor) 1519
- cable conductor database 954
- Cable From/To Data Fields to Report dialog box 1363
- Cable From/To reports
  - about 1402
  - formatting 1465
  - generating 1407
- Cable Insert/Edit Data Fields to Display dialog box 1338
- Cable Insert/Edit dialog box 953
- Cable Label Data Fields to Report dialog box 1364
- cable markers
  - about 930
  - cable conductor database 954
  - colors 954
  - database 954

- editing 953
- inserting 742, 931, 939, 943, 945, 947, 949, 953
- multiple 949, 953
- naming conventions 298
- shields 956
- source and destination
  - markers 1996
- symbols 427, 576
- updating 953
- Cable Summary Data Fields to Report dialog box 1358
- Cable Summary reports
  - about 1402
  - formatting 1467
  - generating 1407
- cables
  - cable conductor database 954
  - colors 954
  - exporting data for Cable & Harness 1519
  - fanning wire markers 1020–1026
  - importing occurrences from
    - Inventor 1166–1167
  - label data in reports 1364
  - marker symbols 427, 576, 930
  - multiple cables 1338
  - report data fields 1338, 1358, 1363
  - reports 1402, 1407, 1465, 1467
  - source and destination
    - markers 1996
  - tags 953
  - terminal information 1087
- capacitive switch symbols 526
- capacitor symbols 426, 575
- Catalog Code Assignment tab (Terminal Strip Editor) 1083, 1087
- catalog information
  - assigning to components 1283, 1285, 1300
  - cable markers 939, 943, 945, 947, 953
  - component data 748, 753
  - editing footprint lookup files 1596
  - missing catalog assignments 1304
  - multi-connection sequences 1138

- multiple BOM part numbers 755–756
- multiple part numbers 1578
- part numbers 1303
- pin lists 1311
- PLC modules 590, 596
- terminal catalog codes 1046, 1083
- tracking changes to 1200
- updating child codes 883
- Catalog Lookup File dialog box 207
- Catalog Search Results dialog box 1293
- catalog tables
  - creating 1294
  - families 1294
  - structure 1277
- Catalog Values dialog box 1293
- catalogs
  - adding components 1295
  - adding records 1298
  - adding tables 1299
  - assigning information to
    - components 1283, 1285, 1300, 1304
  - catalog lookup files 182, 206–207
  - copying information from
    - projects 1283, 1300
  - create project-specific 1281
  - database structure 1277
  - database tables 1279
  - default MFG values 1279
  - editing 1291, 1295, 1298
  - family tables 1271
  - inserting components from 776
  - inserting footprints from 1555, 1557
  - installing manufacturer
    - content 1274
  - linking to web pages 1277
  - LISTBOX\_DEF table 1279, 1291
  - lookup tables 1294
  - migrating 129
  - miscellaneous 1283
  - missing assignments 1304
  - moving files 1272
  - multiple catalogs 1273, 1283, 1303, 2045
  - opening 1291
  - project-specific 1283
  - searching 1285, 1293
  - subcatalog entries 1330
  - tables 1271
- CATEGORY field 135, 620
- cblcolor.dat file 954
- cells (terminal tables) 1110
- Change Attribute Size dialog box 874
- Change Attribute/Text Justification dialog box 871
- Change/Convert Wire Type dialog box 277, 912
- checking
  - attributes 360
  - Bill of Materials 1303
  - cross-references 813, 815
  - projects in or out 2134
  - wires 978
- Child Contact and Panel Update from Schematic Parent dialog box 883
- child-parent relationships
  - about 342
  - attributes 320–321
  - child cable markers 931
  - editing child components 769, 773
  - inserting child components 769, 773
  - location codes 882–883
- CIP (Customer Involvement Program) 6
- circuit breakers 378, 454, 458, 462
- Circuit Builder
  - about 688
  - adding new circuits 2032
  - AEC\_CIRCS sheet 2039
  - AutoLISP and 2048
  - build direction 2052
  - bus wire spacing 2053
  - child contacts 2063
  - circuit codes sheet 2041
  - Circuit Configuration dialog box 710
  - Circuit Selection dialog box 708
  - circuit templates 2037
  - conditional insertion 2051

- configuring circuits 693
- customizing circuits 655, 2006, 2044
- defaults 2076
- energy savings 26
- inserting circuits 690
- mapping motor parameters 2066
- MCC database 681
- mcc.mdb files 681
- motor symbol tags in wire numbers 2059
- multi-pole insertion 2052
- multiple catalogs 2045
- new features 27
- power feed circuits 26
- predefining attribute values 2047, 2072
- Select Motor dialog box 711
- spreadsheets 2045
- stretching and connecting wiring 2082
- tag format 2068
- testing circuits 2043
- trimming wires 2050
- wire numbers 2070, 2075
- wire types 2056
- circuit code sheets 2041
- Circuit Configuration dialog box 710
- Circuit Scale dialog box 736
- Circuit Selection dialog box 708
- circuit templates 2037, 2044
- circuits
  - about 724
  - adding 2032
  - AEC\_CIRCS sheet 2039
  - annotations 708
  - attributes 2047–2048, 2072
  - build direction 2052
  - bus wire spacing 2053
  - child contacts 2063
  - Circuit Builder 655, 2006
  - circuit codes sheet 2041
  - circuit templates 2044
  - conditional components 2051
  - configuring 693, 710
  - copying 725
  - defaults 2076
  - dual one-line circuits 706
  - icons 1244, 1247, 1257, 2119
  - inserting 690, 708, 729, 736, 742
  - mapping motor parameters 2066
  - marker blocks 2037–2038
  - motor symbol tags in wire numbers 2059
  - moving 726
  - multi-pole insertion 2052
  - multiple catalogs 2045
  - one-line circuits 700, 703
  - options 2039
  - power feed circuits 694, 696, 699
  - referencing existing 724
  - reusing 735
  - saving 728, 735
  - selecting 708
  - stretching and connecting wires 2082
  - tag formats 2068
  - templates 2037
  - testing 2043
  - trimming wires 2050
  - WBlocked circuits 729, 736
  - wire numbers 2070, 2075
  - wire types 2056
- cleaning drawings 1688
- clients
  - client-specific libraries 190–191
  - client-specific title blocks 190–191
  - project setup 192
  - subdirectories 190
- clocks 551
- CODE attribute 2037, 2041
- codes
  - copying values to components 1582, 1584
  - drawing parameters 239
  - family codes 1271
  - filtering reports 1318
  - level codes 1620
- COILPINS field 1311, 1984
- coils
  - checking 813, 815
  - pin assignments 1311

- collaboration
  - collaborative design 158
  - Vault setup 2134
- colors
  - cable markers 939, 943, 945, 947, 953
  - cables 954
  - wires 988, 990
- columns (database tables) 685
- columns (report tables) 1322
- comma-delimited files
  - exported component data 1502
  - exported panel layout data 1506
  - exported PLC data 1503–1505
  - exported terminal data 1506–1507
  - exporting 1501, 1503
  - updating drawings with data 1508
- commands
  - adding icons for 1234, 1242, 1264
  - adding to submenus 1249
  - AutoCAD Electrical commands 2148
  - Conduit Marker commands 116
  - Conversion commands 115
  - Extra Libraries commands 117
  - icon properties 1254
  - list of 2148
  - Main Electrical commands 94, 104
  - Panel Layout commands 108
  - Power Check commands 117
  - Ribbon interface 25
  - submenu properties 1259
  - triggering with icons 2119
  - Vault commands 2134
- comments 1200
- Compare Drawing and Project Settings dialog box 241
- comparing project settings 240–241
- Component Annotation dialog box 1644
- Component Annotation from External File dialog box 760
- Component Catalog Lookup dialog box 1294
- Component Cross-Reference dialog box 812
- Component Data Export dialog box 1502
- Component Data Fields to Report dialog box 1378, 1937
- Component Exception reports
  - about 1428
  - formatting 1448
  - generating 1433
- Component Reference Listing dialog box 815
- Component reports
  - about 1402, 1428
  - fields in 1378
  - formatting 1480
  - generating 1416, 1427
  - subcatalog entries 1330
- component tables 1271
- component tags
  - settings 211
  - WD\_M block attributes 253
- Component Wire List Data Fields to Report dialog box 1370
- Component Wire List reports
  - about 1402
  - fields in 1370
  - formatting 1471
  - generating 1410
- components
  - adding symbols to icon
    - menus 1232, 1234, 1237, 1239, 1264, 2119
  - adding to catalogs 1295
  - alignment 798, 800
  - annotations 760
  - attributes 798, 861, 868–869
  - balloons 1600–1602
  - catalog data 748, 753, 1283, 1285, 1300
  - catalog lookup tables 1294
  - catalogs of 1291, 1298
  - checking coils or contacts 813, 815
  - child components 320, 769, 773
  - conditional components 2051
  - copying 774
  - copying code values to 1582, 1584
  - cross-references 748, 753, 809–810, 812, 815
  - data fields for reports 1344, 1378

- deleting 798–799, 1585
- descriptions 761, 868
- duplicates 1686
- editing 748, 753
- equipment lists 782, 784–785
- exceptions in reports 1342
- exporting data 1502
- extracting 949, 953
- family codes 1271
- fence crossing points 775–776
- flipping or reversing 805–806
- hydraulic 1676
- icon properties 1252
- importing from Inventor 1166–1167
- inserting 738, 742, 774–776
- inserting from catalogs 776, 778
- inserting from equipment lists 789
- inserting from panel lists 790–791, 794
- installation codes 748, 753
- interconnecting components 919
- jumpers 856–857
- layers 261
- location codes 748, 753, 881, 892
- location mark symbols 885, 887
- lookup files 782, 784–785
- manipulating 798
- moving 798, 801
- multiple catalogs 1273
- naming conventions 298
- panel components 1536–1538
- parent components 320
- part numbers 1283, 1285, 1293
- peer-to-peer relationships 1981
- pin numbers 764
- pins 748, 753
- PLC database information 630
- ratings 748, 753, 807–808
- removing sequencing 1611
- reports 1402, 1416, 1428, 1433, 1435, 1448, 1451, 1480
- scouting 798, 800
- settings 211
- signals 848–849
- spacing 1544
- splitting 798, 802, 805
- stretching 798, 802
- surfing 1187
- swapping contact states 809
- switches 748
- tables 1271
- tags 748, 753, 757–759, 877–879
- terminals 1040
- text 864–866
- updating 332–333, 336–338, 883
- Components tab (Drawing Properties dialog box) 225
- Components tab (Properties dialog box) 211, 2125
- conditional components 2051
- conditionally trimming wires 2050
- Conduit Marker Data Fields to Display dialog box 1332
- Conduit Marker Report dialog box 1635
- Conduit Marker Setup dialog box 1631
- Conduit Marker toolbar 116
- conduit markers
  - about 1626
  - data fields for reports 1332
  - editing 1627, 1631
  - inserting 1627, 1631
  - reports 1634–1636
  - scale 1631
  - support files 1633
- conduits
  - about 1626
  - reports 1635–1636
  - routing data for reports 1396
  - size 1631
  - spare wires 1632
  - support files 1633
  - tags 1631
- configuration
  - dual one-line circuits 706
  - naming conventions 298
  - one-line circuits 703
  - panel drawings 1527, 1529
  - power feed circuits 696, 699
  - settings lists 241
- connections
  - angled tee wiring connections 1029
  - attribute information 1587–1588

- customizing 2112
- direct-to-terminal wire
  - connections 1029
- displaying 1132
- erasing connection codes 1132
- exporting data 1504
- from/to reports 1419, 1484
- interconnecting components 919
- level/routing wire connections 1029
- multi-connection sequences 1134–1135, 1138
- PLC modules 591
- reports 1368, 1409, 1428, 1441, 1461, 1469
- schematic attributes 320
- schematic wire connections 1029
- sequencing 1029–1031, 1037, 1134
- stretching wires 2082
- symbols 339
- tee markers 1033–1034
- templates 351
- wire connections 353
- wire tools 349
- Connector Details Data Fields to Report dialog box 1372
- Connector Details reports
  - about 1402
  - fields in 1372
  - formatting 1474
  - generating 1412
  - plug and jack options 1330
- Connector Layout dialog box 1159
- Connector List tab (Connector Selection dialog box) 1174
- Connector Pin Numbers in Use dialog box 1161
- Connector Plug Data Fields to Report dialog box 1374
- Connector Plug reports
  - about 1402
  - fields in 1374
  - formatting 1476
  - generating 1413
  - pin charts 1330
- Connector Selection dialog box 1174
- Connector Summary Data Fields to Report dialog box 1376
- Connector Summary reports
  - about 1402
  - fields in 1376
  - formatting 1478
  - generating 1415
- connectors
  - adding pins to 1148
  - breaking 1159, 1167
  - connector lists 1174
  - data fields in reports 1372
  - deleting pins 1149
  - fixed spacing 1142
  - importing 1174–1175
  - in-use pin numbers 1161
  - inserting 1040, 1142, 1157
  - keyboard shortcuts 1142
  - layout 1159, 1167
  - lists 1174
  - moving pins 1151
  - multi-connection sequences 1134–1135, 1138
  - naming conventions 298
  - no wirenumber changes
    - symbols 400, 403, 513
  - pin numbers 1150, 1152, 1161
  - plug report data 1374, 1413, 1476
  - point-to-point tools 1140
  - reports 1402, 1412–1413, 1415, 1474, 1476, 1478
  - reversing 1142, 1144
  - rotating 1142–1143
  - sequencing 1134
  - splices 1185
  - splitting 798, 802, 805, 1147
  - stretching 1146
  - summary report data 1376, 1415, 1478
  - swapping pins 1150
  - symbols 400, 403–404, 407, 513, 516
  - types of 1157, 1167
  - wire crossings 1142
  - wirenumber changes symbols 404, 407, 516



constraints 1065

contacts

- checking 813, 815
- contact states 809
- contact switch symbols 545
- Form C contacts 827
- graphical cross-references 822, 824
- pin lists 1305–1307, 1309, 1311
- skipping during
  - cross-referencing 813
- symbols 379, 476
- table cross-references 827, 830, 832
- types of 1313
- updating 883

continuing surf sessions 1187

Conversion toolbar 115

Convert promis.e Project dialog box 1641

Convert Text to Attribute Definition dialog box 1645

Convert Text to Attribute dialog box 356

convert text to wire numbers 1940

Convert VIA ECDS or Jr. Project to AutoCAD Electrical dialog box 1650

convertible contact pin annotations 1313

converting

- geometry to Electrical-aware blocks 1651, 1653, 1656–1657, 1659
- lines 275
- lines to wire connections 1651, 1653, 1656–1657, 1659
- mapping non-Electrical blocks 1642, 1644
- non-Electrical arrow symbols 1647
- non-Electrical objects 2099
- non-intelligent ladders 966, 968
- promis.e files 1638–1639, 1641
- replacing blocks 1663–1665
- text to attributes 355–356, 1645
- text to other languages 1202–1203
- text to wire numbers 1646
- VIA drawings 1648, 1650
- wires to other types 275, 277, 912

Copy Active Drawing Settings To dialog box 255

Copy Installation/Location/Mount/Group to Components dialog box 1584

Copy Level Assignments dialog box 1614

Copy Project Step 1 - Select Existing Project to Copy dialog box 156

copying

- attributes 255, 337
- catalog information 1283, 1300
- circuits 725
- code values to components 1582, 1584
- database tables 682
- icons 1234
- migration options 134
- panel assemblies 1565
- panel footprints 1562
- PLC modules 602
- projects 142
- properties 1058
- sequencing 1614
- wire numbers 1000

COPYTAG attribute 329

costs per kwh 720

count (components) 1303

counter relay symbols 481

coupling device symbols 568

Create New Circuit dialog box 1244

Create New Drawing dialog box 171, 1895, 1913

Create New Project dialog box 156

Create New Submenu dialog box 1249

Create Project-Specific Catalog Lookup File dialog box 1281

Create/Edit Wire Type dialog box 271, 902, 912, 1901, 1914, 1940

CRM tables 1271

Cross-Reference Component Override dialog box 818

Cross-Reference tab (Properties dialog box) 2125

Cross-Reference Table Data Fields to Display dialog box 1397

- cross-references
    - about 809
    - advanced techniques 1981
    - annotations 839
    - attributes 320
    - checking coils or contacts 813, 815
    - child components 769, 773
    - child location codes 882–883
    - component data 748, 753
    - component setup 815
    - creating 812
    - dashed lines 846–848
    - destination symbols 809
    - displaying 817
    - drawing properties 812
    - drawing setup 815
    - formatting 817
    - graphical formats 822, 824
    - hiding 813
    - inserting 742
    - multi-line text 880
    - naming conventions 298
    - overriding 818
    - processing 810
    - project properties 812
    - project setup 815
    - project-wide changes 1199
    - removing overrides 815, 819
    - reports 809, 1397, 1399
    - settings 216, 229, 815, 818–819
    - skipping contacts 813
    - source symbols 809
    - stand-alone symbols 430, 838–839, 844–845
    - surfing on reports 812
    - symbols 579
    - tables 827, 830, 832–833
    - text format 820
    - visibility 813
      - WD\_M block attributes 253
  - Cross-References tab (Drawing Properties dialog box) 229
  - Cross-References tab (Properties dialog box) 216
  - CSV files
    - component spreadsheet data 1536
    - external component lists 182
      - importing 1175
  - current converter symbols 551
  - current protection relay symbols 479
  - current switch symbols 545
  - current transformer symbols 469
  - Customer Involvement Program 6
  - customizing
    - attribute templates 2107
    - circuits 655, 2006
    - icon menus 2119
    - migrating older customization files 131–132
    - panel footprints 2105
    - symbols 2083
    - terminals 2094
    - wire connections 2112
- D**
- dashed lines
    - attributes 354
    - cross-references 846–848
    - point-to-point tools 1140
    - reference arrows 847–848
  - DAT files
    - alternate icon menu files 1260
    - editing 1237, 1264, 2119
    - icon menu files 1250
    - locking 1237
  - Data Fields to Display dialog box 1399
  - data imports 1166–1167
  - databases
    - cable conductor database 954
    - catalog databases 755–756, 1271, 1273, 1277, 1279
    - change-tracking tables 1200
    - Circuit Builder 681
    - copying tables 682
    - deleting tables 683
    - ECDS conversions 1648, 1650
    - editing tables 685
    - electrical standards database 2044
    - electrical standards database editor 681, 687
    - exporting data to 1501–1507

- footprint lookup files 1594
- importing catalog information
  - from 1283, 1300
- importing connector data 1175
- language translation tables 1202, 1204
- merging 129
- migrating 129
- motor lookup database 712
- moving files 1272
- opening tables 682
- pin lists 1305–1307, 1309, 1311
- PLC database 2005
- rebuilding 196
- scratch databases 195
- terminal properties 1060–1062, 1064
  - user data 854–855
- DC motor symbols 490
- de-rating factors 720
- debugging projects 1686, 1688–1689, 1692, 1694
- default libraries 301
- default\_cat.mdb files 1271
- default.grp files 182
- default.inst files 182
- default.loc files 182
- default.mnt files 182
- default.wdt files 1213, 1221
- Define Layers dialog box 261
- deleting
  - components 798–799, 1585
  - database tables 683
  - drawings 144
  - jumpers 1109
  - location mark symbols 885
  - marker blocks 2037
  - pins from connectors 1149
  - projects 189
  - tracking deleted objects 1200
  - wire gaps 958
  - wire numbers 1010
- deployment 1989
- description defaults files 182
- descriptions
  - adding 761
  - exporting data 1505
  - formatting 763
  - language tables 762
  - moving 868
  - multiple descriptions 1213, 1221
  - reports 1420, 1486
  - symbols 339
  - tracking changes to 1200
  - translating 1202–1203
  - updating 883, 1224
- destination arrows 1647
- destination markers
  - adding 1021
  - advanced techniques 1996
  - fanning 1020
  - layers 1022–1023, 1025–1026
  - styles 1022–1023, 1025
- destination signal arrows 1011–1012, 1014, 1647
- destination wire signal symbols 298, 320
- destinations
  - cross-reference symbols 809, 844–845
  - listing codes 1019
  - terminals 1078
  - toggling installation codes 1106
  - toggling location codes 1105
  - tracking changes to codes 1200
- devices
  - box symbols 428, 577
  - operating symbols 557
- diac diode symbols 575
- dialog boxes
  - Component Data Fields to Report 1937
  - Create New Drawing 1895, 1913
  - Create/Edit Wire Type 1901
  - Surf 1944
- Din Rail dialog box 853
- din rails
  - about 853
  - inserting 853
- diode symbols 426, 575
- direct-to-terminal wire connections 1029
- direction
  - build direction 2052

- symbols 557–558
- directories 182
- disconnect 1 pole symbols 462
- disconnects 378, 461–462
- Display tab (Connector Selection dialog box) 1174
- Display tab (Insert Connector dialog box) 1157
- displaying
  - attributes 869
  - cross-references 813, 817
  - drawings 172
  - missing catalog assignments 1304
  - sequencing 1031, 1611
  - terminal associations 1055, 1057
  - terminal connections 1132
  - terminal strips 1129
  - wire numbers 1010
  - wires 978
- dividers 1104, 1157, 1167
- dot tee markers 1033
- drafting settings 1896, 1913
- dragging icons on menus 1234
- Drawing Audit dialog box 1694
- Drawing Format tab (Drawing Properties dialog box) 233
- Drawing Format tab (Properties dialog box) 220, 2125
- Drawing List Data Fields to Display dialog box 1334
- Drawing List Display Configuration dialog box 174
- Drawing List Report dialog box 192
- Drawing Properties dialog box
  - codes for replaceable parameters 239
  - Components tab 225
  - Cross-References tab 229
  - Drawing Format tab 233
  - Drawing Settings tab 222, 2125
  - Styles tab 231
  - Wire Numbers tab 228
- Drawing Settings tab (Drawing Properties dialog box) 222, 2125
- drawing shapes 1551, 1555
- drawing standards 206, 2125, 2127
- drawings
  - adding to projects 140
  - archiving 187–188
  - auditing 1686, 1688–1689, 1692, 1694
  - batch plotting 1191
  - cleaning 1688
  - comments in 1200
  - creating 168
  - cross-references 815
  - defaults 202
  - description 144
  - displaying 172
  - generating 630–631, 635, 639
  - grouping in projects 144
  - inserting reports into 1318, 1322, 1330
  - moving to another 1190
  - previewing 144
  - processing 196
  - project-wide changes 1199
  - properties 202–203
  - publishing as DWF files 1208
  - publishing to the Web 1205–1207
  - removing 144
  - reordering 144
  - reports 192, 1334
  - settings 222, 233
  - surfing 1187
  - task list of changes 194
  - templates 245
  - title blocks 1213, 1221
  - tracking changes 1200
  - unavailable files 198
  - updating 1224
  - updating with imported data 1508
  - WD\_M blocks 253
- dual one-line circuits 706
- dual power feed circuits 699
- duplex receptacle symbols 427, 576
- duplicate numbers 1686, 1688, 1694
- duplicate tags 1686, 1688, 1694
- DWF files
  - exporting 1208
  - publishing web pages 1205–1206
- DXF files 1207

## E

- earth symbols 423, 570
- ECDS to AutoCAD Electrical
  - conversions 1648, 1650
- Edit Attribute dialog box 861
- Edit Catalog Record dialog box 1298
- Edit Child Component dialog box 769, 773
- Edit Component - IEC dialog box 753
- Edit Component dialog box 748
- Edit Conduit/Wire Way Label dialog box 1631
- Edit dialog box 784, 1062, 1309
- Edit Entry dialog box 1138
- Edit Footprint Record dialog box 1599
- Edit Language Lookup File dialog box 1204
- Edit Miscellaneous and Non-AutoCAD Electrical Attributes dialog box 331
- Edit Multi-Connection Sequence Terminal Symbol dialog box 1135
- Edit PLC I/O Point dialog box 624
- Edit PLC Module dialog box 596
- Edit Record dialog box 780, 785, 1064, 1311
- Edit Report dialog box 243, 1323
- Edit Terminal dialog box 1100
- Edit Terminal Jumpers dialog box 1127
- Edit User Table Data dialog box 855
- Edit Wire Connection Sequence dialog box 1037
- Edit/Delete Jumpers dialog box 1109
- editing
  - attributes 349–350, 861
  - cable colors 954
  - cable conductor database 954
  - cable markers 939, 943, 945, 947, 953
  - catalogs 1291, 1295, 1298
  - child components 769, 773
  - components 748, 753
  - conduit markers 1627, 1631
  - cross-reference symbol mapping tables 832
  - database tables 685
  - footprint lookup files 1595–1596, 1599
  - footprints 1565, 1569, 1574
  - icon menu properties 2119
  - icon menus 1234, 1237, 1264
  - ladders 963–966, 968–969
  - language database tables 1204
  - marker blocks 2038
  - multi-connection sequences 1135, 1138
  - multi-line text 880
  - part numbers 1300
  - pin lists 1306, 1309, 1311
  - pin numbers 1140, 1152
  - PLC database 606
  - PLC modules 596, 616
  - records 780
  - reports 1323
  - retagging components 879
  - RSLogix data 642
  - schematic lookup files 782, 784–785
  - sequencing 1030, 1037, 1613
  - signal arrows 1012
  - spreadsheet data 1500
  - symbols 331, 893
  - terminal associations 1055
  - terminal jumpers 1109, 1123, 1127
  - terminal strips 1078, 1128
  - terminals 606, 1046, 1050, 1053, 1062, 1064, 1100, 1565, 1569, 1574
  - text 864–867
  - user-defined attributes 1509–1510, 1512
  - wire jumper assignments 856–857
  - wire numbers 991–992, 994, 1007
  - wire types 271, 902
  - Xdata 1695
- effect symbols 560
- Electrical Audit dialog box 1692
- Electrical Database Builder 1648, 1650
- electrical standards database 711, 2044
- electrical standards database editor 681, 687
- electrolytic symbols 575

- electronic symbols 426, 575
  - enclosure light symbols 423
  - end barriers 1104
  - energy flow 560
  - energy savings 26
  - ENV files 279
  - environment files 138, 279
  - equipment lists
    - BOM data and 785
    - inserting components from 785–787, 789
    - inserting footprints from 1557–1559, 1561
    - schematic lookup files 782, 784–785
  - equipotential bond symbols 570
  - error checking 1686, 1688–1689, 1692, 1694
  - error reports
    - component exceptions 1342, 1433, 1448
    - cross-references 809
    - exception reports 1428
    - signal reports 1019
    - symbol audits 357, 360
    - terminal exceptions 1352, 1440, 1458
    - wire annotation exceptions 1348, 1437, 1454
  - Excel files
    - din rails 853
    - exporting component data 1502
    - exporting panel layout data 1506
    - exporting PLC data 1503–1505
    - exporting spreadsheet data 1500–1501, 1503
    - exporting terminal data 1506–1507
    - importing 1175, 1500
    - mapping to blocks 1663–1665
    - PLC database content 630
    - reports 1318
    - RSLogix data 640–642
    - structure 1175
    - updating drawings with data 1508
  - exception reports
    - auditing drawings 1692
    - component exceptions 1342, 1433, 1448
    - cross-references 809
    - terminal exceptions 1352, 1440, 1458
    - wire annotation exceptions 1348, 1437, 1454
  - excluding contacts 813
  - expanding catalog tables 1295
  - exploding blocks 1654
  - Export to Spreadsheet dialog box 1501
  - exporting
    - comma-delimited files 1501–1507
    - component data 1502
    - data for Cable & Harness 1519, 1521–1522
    - database files 1501–1507
    - DWF files 1208
    - panel layout data 1506
    - PLC data 1503–1505
    - reports 1318
    - RSLogix data 640–642
    - spreadsheet data 1500–1507
    - terminal data 1506–1507
    - Unity Pro data 645–646, 651–652
    - web pages 1205–1207
  - external codes 1330
  - external component files 182
  - external connections 1132
  - external destinations 1105–1106
  - external jumpers 1122–1123
  - Extra Libraries toolbars 117
  - extra wire numbers 970
  - extracting
    - components 949, 953
    - wires 949, 953
- ## F
- families
    - family tables in catalogs 1271, 1294
    - family tag code map files 182
    - family type naming
      - conventions 298
    - overriding family tags 2125

- overriding tags 759
- Fan-In/Fan-Out Signal Destination dialog
  - box 1025
- Fan-In/Fan-Out Signal Source dialog
  - box 1024
- Fan-In/Out Single Line Layer dialog
  - box 1026
- fanning markers in or out
  - about 1020
  - advanced techniques 1996
  - destination markers 1021, 1025
  - layers 1022–1023, 1026
  - source markers 1021, 1024
  - styles 1022–1023
- fault symbols 562
- fence crossing points 775–776
- fields
  - BOM data in reports 1340, 1356, 1380
  - cable data in reports 1338, 1358, 1363–1364
  - catalog tables 1277, 1279
  - component data in reports 1344, 1378
  - conduit marker fields in reports 1332
  - connector data in reports 1372, 1374, 1376
  - cross-reference data 1397, 1399
  - drawing file data in reports 1334
  - missing level/sequence assignments 1346
  - nameplate data in reports 1350
  - pin lists 1309, 1311
  - PLC data in reports 1368, 1386, 1390
  - report format files 1442, 1444
  - selecting for reports 1330
  - terminal data in reports 1388, 1393
  - terminal strip tables 1113
  - wire data in reports 1354, 1370, 1384, 1394, 1396
- file formats
  - project files 187
  - web formats 1205–1206
- files
  - copying into projects 142
  - migrating 129
  - processing 198
- Files Unavailable for Processing dialog
  - box 198
- filtering
  - catalog records 1277
  - contact types 1313
  - report data 1318
- Find or Replace Wire Numbers dialog
  - box 987
- Find/Edit/Replace (drawing or project)
  - dialog box 865
- Find/Edit/Replace Component Text dialog
  - box 866
- Find/Replace Terminal Text dialog
  - box 867
- finding
  - drawings 865
  - projects 865
  - terminal property information 1060
  - text 864–867
  - wire number text 986–987
- fixed component tags 877–878
- fixed resistor symbols 426, 575
- fixed spacing 1142, 1157, 1159, 1167
- fixed wire numbers 970, 991–992, 994
- Fixed/Unfix Component Tag dialog
  - box 878
- flashing beacon light symbols 502
- flipping
  - components 805–806
  - connectors 1144
  - wire gaps 958
  - wire numbers 1003
- float/level switch symbols 545
- flow
  - energy flow symbols 560
  - flow switch symbols 411
  - flow switches 545
  - symbols 559
- folders 129
- following signals 848–849
- fonts 1195
- foot switch symbols 415, 545

- Footprint Database File Editor 1596, 1599
- Footprint dialog box 1555
- Footprint Lookup dialog box 1596
- footprint lookup files 182, 1595–1596, 1599
- footprint\_lookup.mdb files 1594
- footprints
  - attribute templates 1563
  - attributes 329, 1526
  - automatic updates 1532
  - catalog lookup tables 1294
  - configuration 1529
  - copying 1562
  - copying panel assemblies 1565
  - creating with Symbol Builder 2105
  - deleting 1585
  - din rails 853
  - displaying sequencing 1611
  - editing 1565, 1569, 1574
  - extracting footprint lists 790–791, 794–796
  - inserting 1538, 1540, 1542, 1552
  - inserting from catalogs 1555, 1557
  - inserting from equipment lists 787, 1557–1559, 1561
  - inserting from icon menus 1544, 1548, 1551
  - inserting from vendor menus 1545, 1547
  - inserting manually 1551, 1555
  - inserting panel assemblies 1564
  - inserting with spreadsheet data 1536–1537
  - layers 258
  - level assignments 1614, 1619, 1622
  - lookup database file editor 1596
  - lookup files 1534, 1594–1596, 1599
  - mapping 1534
  - naming conventions 298
  - reports 1428
  - sequencing 1613
  - spacing 1544
  - types of symbols 342
  - wire information 1587–1588, 1590, 1592
  - Xdata 1527
- Force Attribute/Text to a Different Layer dialog box 863
- force symbols 557–558
- Form C contacts 827
- Format - Schematic Layout Wire Connection Annotation dialog box 1531
- format files
  - about 1442
  - defining 1444
  - missing level/sequence assignments reports 1452
  - panel bill of materials reports 1446
  - panel component exception reports 1448
  - panel component reports 1451
  - panel nameplate reports 1456
  - panel terminal exception reports 1458
  - panel wire annotation exception reports 1454
  - panel wire connection reports 1461
  - schematic bill of material reports 1463
  - schematic cable from/to reports 1465
  - schematic cable summary reports 1467, 1469
  - schematic component reports 1480
  - schematic component wire list reports 1471
  - schematic connector details reports 1474
  - schematic connector plug reports 1476
  - schematic connector summary reports 1478
  - schematic missing bill of material reports 1483
  - schematic PLC I/O address and descriptions reports 1486
  - schematic PLC I/O component connection reports 1469
  - schematic PLC used so far reports 1493



- schematic terminal numbers
  - reports 1489
- schematic terminal plan
  - reports 1491
- schematic wire from/to reports 1484
- schematic wire label reports 1495
- formatting
  - cross-references 817, 820
  - description text 763
  - reports 1442, 1444
  - wire annotations 1531, 1592
  - wire numbers 988, 990
- frequency meter symbols 551
- frequency relay symbols 482
- from/to reports
  - cable data 1363, 1407, 1465
  - controlling sequencing 1029
  - location codes in 1427
  - types of 1402
  - wire data 1384, 1419, 1484
- fuse switch symbols 465
- fuses 376, 465
- fusible disconnect symbols 461

## G

- gaps
  - auditing drawings 1689
  - wire gaps 958
- gate valves 421
- gauge
  - gauge label files 182
  - labels 922–924
  - wires 988, 990
- General Data Export dialog box 1503
- generating
  - automatic reports 1496
  - reports 1318, 1330, 1402–1403, 1428, 1430, 1497, 1499
  - terminal strip tables 1113
- generator symbols 491
- generic device box symbols 428, 577
- geometry
  - adding to blocks 1660

- converting to Electrical-aware
  - blocks 1651, 1653, 1656–1657, 1659
  - exploding blocks 1654
  - footprint lookup files 1594
- global search and replace 864–867
- globe valves 421
- graphic cross-references 822, 824, 827, 830, 832
- graphic layers 264
- graphic terminal layout 1093
- Graphical Cross-Reference Format Setup
  - dialog box 824
- green design 26
- grids
  - I/O variables 651
  - terminal grid 606
  - X Zone grid 234
  - X-Y Grid 236
- ground symbols 423, 570
- grounding conductors 720
- group codes
  - copying 1584
  - group code files 182
- groups 144
- GRP files 182

## H

- hardware files 651
- HCRM values 1271
- header information (PLC) 1503
- headers in reports 1330
- heater element symbols 575
- help 3, 6
- hiding
  - cross-references 813
  - wire numbers 1010
- horizontal ribbon 118
- horn symbols 423, 570
- hour meter symbols 551
- HTML files 1205–1206
- Hydraulic drawings 1895
- hydraulic symbols 1896
  - attributes 329
  - by-pass flow regulator 1909

- checkvalve flow left 1897, 1908, 1910
  - filters 1899, 1909
  - fixed displacement pump 1898
  - general valves 1897, 1906, 1910
  - inserting 742, 1676
  - insertion 1897–1899, 1903, 1905–1906, 1908, 1910
  - libraries 306
  - meters 1906
  - motors and pumps 1898
  - naming conventions 298
  - pressure gauge 1906
  - pressure relief valves 1903
  - reservoir 1899
  - restrictor with variable output flow 1909
  - shut off valve open 1897, 1906
  - single ended piston rod 1909
  - solenoid spring return 1908
  - uni-directional pump 1898
- I**
- I/O modules
    - address and descriptions reports 1386, 1420, 1486
    - advanced techniques 2005
    - annotating points 622
    - connection reports 1409, 1469
    - editing points 620, 624
    - exporting connection data 1504
    - exporting data for Unity Pro 652
    - I/O parametric build symbols 298
    - importing RSLogix data 640–642
    - importing Unity Pro data 645–646, 651
    - inserting points 621
    - PLC address database information 601
    - PLC modules 591
    - schematic attributes 320
    - types of reports 1402
  - I/O variables
    - exporting 652
    - Unity Pro data 651
  - Icon Menu Wizard
    - about 1232, 1234, 1237
    - circuit icons 1244, 1247, 1257
    - command icons 1242, 1254
    - component icons 1239, 1252
    - icon properties 1234
    - menu properties 1250
    - submenus 1249, 1259
  - Icon Menu Wizard dialog box 1237, 2119
  - icon menus
    - about 1232
    - adding circuits 728, 1244, 1247, 1257
    - adding commands 1242, 1254
    - adding components 1239, 1252
    - adding icons 1234
    - advanced techniques 2119
    - alternate files 1260
    - best practices 2119
    - customizing 2119
    - editing 1264
    - file structure 1264
    - footprint display syntax 1599
    - icon properties 1234
    - inserting panel footprints with 1544–1545, 1547–1548, 1551
    - locking menus 1237
    - menu properties 1250
    - migrating 2119
    - pages 2119
    - preferences 206
    - settings 1237
    - sharing with multiple users 1989
    - submenus 1249, 1259
  - icons
    - adding to menus 1232, 1234, 1237
    - changing images 2119
    - creating 1232, 1234, 1237
  - IEC mode
    - cable markers 943, 947
    - child components 773
    - component tags 193
    - configuring projects for 2125, 2127
    - drawing settings 222

- editing components 753
  - IEC symbols 441
  - inserting components 753
- IEC Tag Mode Update dialog box 193
- IEC tags
  - new drawings 171
  - updating 193
- illuminated push buttons 442
- illuminated selector switches 374
- Import Wire Type dialog box 273, 904
- importing
  - catalog information 1283, 1300
  - connector data 1175
  - data for I/O drawings 635, 639
  - RSLogix data 640–642
  - spreadsheet data 1500, 1508
  - Unity Pro data 645–646, 651
  - wire types 904, 907
- in-line components
  - PLC database information 630
  - PLC-generated drawings 639
  - wiring 630
- in-line wire labels
  - illustrated 398
  - inserting 742
  - schematic attributes 320
  - symbols 509
- in-line wire markers
  - about 925
  - naming conventions 298
- in-line wire numbers 979, 1002
- in-use pin numbers 1161
- incrementing wire numbers 1007
- inductive switch symbols 524
- information lines 1213, 1221
- Insert Accessory dialog box 1104
- Insert Component dialog box 742
- Insert Connector dialog box 1157
- Insert Destination Code dialog box 1014
- Insert dialog box 789
- Insert Footprint dialog box 1551
- Insert Ladder dialog box 963
- Insert Panel Wiring Diagram Terminal Strip Representation dialog box 1615
- Insert Pneumatic Component tool 1912
- Insert Spare Terminal dialog box 1103
- Insert Wire Color/Gauge Labels dialog box 924
- Insert Wire Connection dialog box 353
- Insert/Edit Attributes dialog box 350
- Insert/Edit Cable Marker (2nd+ wire of cable) - IEC dialog box 947
- Insert/Edit Cable Marker (2nd+ wire of cable) dialog box 945
- Insert/Edit Cable Marker (Parent Wire) - IEC dialog box 943
- Insert/Edit Cable Marker (Parent Wire) dialog box 939
- Insert/Edit Child Component - IEC dialog box 773
- Insert/Edit Child Component dialog box 769
- Insert/Edit Component - IEC dialog box 753
- Insert/Edit Component dialog box 748
- Insert/Edit Conduit/Wire Way Label dialog box 1631
- Insert/Edit Panel Level Assignment Component dialog box 1622
- Terminal Strip dialog box 1619
- Insert/Edit Terminal Symbol dialog box 1046
- inserting
  - attributes 346, 350
  - balloons 1600–1602
  - break symbols 1159, 1167
  - cable markers 931, 939, 943, 945, 947, 949, 953
  - child components 769, 773
  - circuits 690, 708, 729, 736
  - components 738, 742, 774, 1538
  - components from catalog lists 776, 778
  - components from equipment lists 785–787, 789
  - conditional components 2051
  - conduit markers 1627, 1631
  - connectors 1040, 1142, 1157
  - cross-reference arrow symbols 847–848
  - destination wire markers 1021

- footprints 1536, 1538, 1540, 1542, 1552, 1562
- footprints from catalogs 1555, 1557
- footprints from equipment
  - lists 787, 1557–1559, 1561
- footprints from icon menus 1544, 1548, 1551
- footprints from vendor
  - menus 1545, 1547
- footprints manually 1551, 1555
- footprints with spreadsheet
  - data 1537
- gauge labels 924
- hydraulic components 1676
- ladder rungs 966
- ladders 960–961, 963
- link line attributes 354
- location boxes 892
- location codes 881
- multi-connection sequences 1138
- multiple components 742
- nameplates 1609–1610
- one-line circuits 700
- P&ID symbols 1681
- panel assemblies 1564
- part numbers 1300
- PLC I/O points 621
- PLC modules 590, 592
- pneumatic components 1671
- power feed circuits 694
- prompts during 617
- reports into drawings 1318, 1322, 1330
- signal arrows 1014–1015
- source wire markers 1021
- spacers 1159, 1167
- spacing inserted items 1544
- spare terminals 1103
- splices 1185
- stand-alone cross-reference
  - symbols 838, 844
- tee markers 1033
- terminal accessories 1104
- terminal strip tables 1070, 1114
- terminal strips 1066, 1615
- terminals 1040, 1046, 1540, 1542
- WBlocked circuits 729, 736
- WD\_M blocks 253, 256
- WD\_PNLM blocks 256
- wire connections 351, 353
- wire jumpers 856–857
- wire labels 922–924
- wire numbers 970–971
- wire tags 972–973
- wire way labels 1631
- wires 913, 917–918, 1140
- installation
  - manufacturer content 1274
  - network deployment 1989
  - symbol libraries 301
- installation codes
  - cable markers 939, 943, 945, 947, 953
  - child components 769, 773
  - component data 748, 753
  - copying 1584
  - installation code files 182
  - location boxes 892
  - multi-connection sequences 1138
  - PLC I/O points 624
  - PLC modules 596
  - terminal strips 1065
  - toggling 1106
  - tracking changes to 1200
  - updating 883
- instrumentation 421, 551
- insulating relay symbols 482
- interconnecting components 919
- internal codes 1330
- internal connections 1132
- internal destinations 1105–1106
- internal jumpers
  - terminal jumpers 1122–1123
  - wire jumpers 856–857
- Inventor
  - exporting data for Cable & Harness 1519, 1521–1522
  - importing data from 1166–1167
- invisible extended entity data
  - (Xdata) 1526–1527, 1695
- item number balloons
  - about 1600

- inserting 1601–1602
- resequencing 1604–1605
- Item Numbering Setup dialog box 211
- item numbers
  - balloons 1600–1601, 1604
  - fixed 1606
  - per-part numbers 211
  - settings 211

## J

- jacks
  - jack connector pin symbols 298
  - report options 1330
- JIC standard 2127
- JIC symbols 366
- JPEG files 1205–1206
- Jr. Projects 1648, 1650
- jumper charts 1071, 1093
- jumpers
  - add-on 1122–1123
  - charts 1071, 1093
  - deleting 1109
  - editing 1109, 1123, 1127
  - external 1122–1123
  - internal 1122–1123
  - terminal jumpers 1078, 1122–1123, 1125, 1127
  - terminal strip assignments 1070
  - wire jumpers 856–857
- justified text 870–871

## K

- key switch symbols 545
- kwh energy loss 720

## L

- labels
  - cable labels 1364
  - gauge labels 922–924
  - reports 1402
  - wire labels 922–924, 1425, 1495
  - X-Y Grid 236

- ladder schematics 1140, 1534
- ladders
  - about 961
  - attributes 960
  - converting non-intelligent ladders 966, 968
  - defaults 960
  - format settings 220, 233
  - inserting 960–961, 963
  - ladder master line references 298
  - line reference numbers 966, 968
  - moving 965
  - naming conventions 298
  - phases 963
  - PLC-generated drawings 635, 639
  - project-wide changes 1199
  - renumbering 963, 969
  - resizing 964
  - rungs 963, 965–966, 968
  - spacing 960, 963, 965
  - tracking changes to reference numbers 1200
  - WD\_M block attributes 253
- Language Conversion dialog box 1203
- language tables
  - descriptions 763, 1202
  - editing 1204
  - opening 762
- language translation 1202–1203
- last-used assignments 1283
- latch relay coils 380
- latching device symbols 567
- layers
  - about 258
  - attribute assignment 331, 862–863
  - component block layers 261
  - configuring for export 1521
  - exporting wire data to Cable & Harness 1519
  - fanning markers 1022–1026
  - footprints 258
  - moving text to other 863
  - multi-wire layers 1996
  - nameplate layers 264
  - non-text graphic layers 264
  - panel layers 258, 264

- renaming 258, 262
- report tables 1322
- schematic layers 258
- settings 220, 233
- WD\_M block attributes 253
- wire layers 265–266, 271, 902, 923–924, 988, 990, 1195
- wire number layers 261, 970
- Layout Preview tab (Terminal Strip Editor) 1093
- Layout tab (Connector Selection dialog box) 1174
- Layout tab (Insert Connector dialog box) 1157
- layouts
  - about 1523
  - automatic updates 1532
  - batch plotting 1191
  - configuration 1527, 1529
  - editing 1565, 1569, 1574
  - exporting data 1506
  - footprint lookup files 1594
  - item number balloons 1600–1602
  - level assignments 1614, 1619, 1622
  - level/routing wire connections 1029
  - nameplates 342, 1609
  - naming conventions 298
  - relationships to schematic drawings 1534
  - reports 1428
  - resequencing item number balloons 1605
  - sequencing assignments 1611, 1613
  - surfing references 1187
  - tag lists 758
  - tagging 1657
  - templates 1563
  - tools 1524
  - wire annotation format 1531
  - Xdata 1526–1527
- leaders
  - wire leaders 922
  - wire numbers 998
- LED light symbols 500
- level assignments
  - boundary boxes 1620
  - components 1622
  - copying 1614
  - displaying 1611
  - missing assignments 1346, 1428, 1436, 1452
  - removing 1611
  - reports 1428, 1436, 1452
  - terminal strips 1619
- Level Code Edit - Boundary Box dialog box 1620
- level codes 1614
- level switches 411
- level/routing wire connections 1029
- lever switch symbols 545
- libraries
  - changing symbol appearance 331
  - client-specific 190–191
  - default 300–301
  - editing symbols in 893
  - hydraulic symbols 306
  - installing 301
  - multiple 300–301
  - P&ID symbols 306
  - paths 300
  - preferences 206
  - substituting symbols 330
- Library Swap -- All Drawing dialog box 337
- library symbols
  - attributes 345, 349
  - auditing 357, 360
  - changing appearance 331
  - client-specific 190
  - converting existing 1642
  - COPYTAG attribute 329
  - creating 339, 342, 344
  - default 301
  - editing attributes 893
  - editing text 893
  - family types 298
  - hydraulic 306
  - layers and 331
  - location 300
  - multiple 300–301
  - naming conventions 282, 298
  - P&ID 306

- predefined annotations 332
  - saving 357, 359
  - schematic attributes 320
  - splitting tag names 299
  - substituting 330
  - swapping blocks 332–333, 336–338
  - Symbol Builder 342
  - TAG1 attribute 321
  - TAG2 attribute 321
  - text size 893
  - types 342
  - updating blocks 332–333, 336–338
  - light dependent electronics symbols 575
  - limit switches 408, 520
  - line reference numbers 966, 968
  - linear direction 557
  - lines
    - blank lines in reports 1330
    - link lines 349, 354
    - PLC module boxes 608, 614
    - wire number leader lines 922
  - LINEx labels 1225
  - link lines
    - attributes 354
    - cross-references 846–848
    - dashed 846–848
    - point-to-point tools 1140
    - tools 349
  - Link Schematic tools 1659
  - link symbols 1661
  - linking
    - catalogs to web pages 1277
    - displaying links 1661
    - replacing text with Electrical-aware entities 1651, 1653, 1659
    - title block attributes 1213
    - title block information 1218, 1220
    - unlinking symbols 1661
  - linking tools 1932
  - list of commands 2148
  - Load or Reload Linetypes dialog box 1915
  - loads 1668–1670
    - wires 720
  - Location Box dialog box 892
  - location boxes 892
  - Location Code Selection for From/To Reporting dialog box 1427
  - location codes
    - cable markers 939, 943, 945, 947, 953
    - child components 769, 773
    - component data 748, 753
    - copying 1584
    - from/to reports 1427
    - inserting 881
    - location boxes 892
    - location code files 182
    - location mark symbols 885, 887
    - multi-connection sequences 1138
    - PLC I/O points 624
    - PLC modules 596
    - terminal strips 1065
    - toggling 1105
    - tracking changes to 1200
    - updating child codes 882–883
  - location mark symbols 298, 885, 887
  - Location Symbols dialog box 887
  - locations of files 182
  - locking icon menu files 1237
  - lookup files
    - footprint lookup files 1595–1596, 1599
    - inserting components 789
    - schematic lookup files 782, 784–785
  - loudspeaker symbols 581
- ## M
- magnetic effect symbols 560
  - magnetic switch symbols 528
  - Main Electrical toolbars 94, 104
  - manufacturers
    - catalog tables 1271
    - inserting footprints from vendor menus 1544–1545, 1547
    - installing additional content 1274
    - MFG fields 1279
    - pin lists 1311
    - PLC database information 601
    - PLC modules 590, 596
    - sorting catalog databases by 1291

- updating 883
- mapping
  - AutoLISP values to title blocks 1227
  - block replacements 1663–1665
  - contact mapping
    - cross-references 822, 824, 827, 830
  - data for import 639
  - editing symbol mapping tables 832
  - imported Inventor data
    - properties 1166–1167
  - ladder diagrams to panel
    - layouts 1534
  - non-Electrical blocks 1642, 1644
  - title block attributes 1213
  - title blocks information 1218, 1220
  - wire labels 922–924
  - wire list data to Inventor Cable & Harness 1519
- Mark and Verify dialog box 1202
- marker blocks 2037–2038
- marking changes 1200
- MARKVERIFY table 1200
- master test pilot lights 391
- MAXNC attribute 1305
- MAXNO attribute 1305
- MAXNONC attribute 1305
- MCC database 681
- mcc.mdb files 681
- MDB files
  - exporting 1501–1507
  - importing 1175
  - location 182
- measurement units 1303
- mechanical controls 566–568
- mechanical footprints
  - attributes 1526
  - Xdata 1527
- mechanical resonance relay symbols 482
- menus
  - adding symbols to 885, 887, 1232
  - alternate icon menus 1260
  - command properties 1254
  - icon menus 1232, 1234, 1237, 1548, 1551
  - main menu properties 1250
  - renaming 1250
  - sharing with multiple users 1989
  - submenus 1249, 1259
  - vendor icon menus 1544–1545, 1547
- Merge Utility 129
- Merge/Copy Options dialog box 134
- merging databases 129
- merging files during migration 129, 134
- meters 421, 551
- MFG fields 1271
- microphone symbols 581
- migrating
  - merge options 134
  - Migration Utility 129
  - PLC database 135, 620
  - settings and customizations 131–132
- Migration Review dialog box 136
- Migration Utility
  - about 129
  - settings 130–132, 134, 136
- minimum active power relay
  - symbols 482
- minimum impedance relay symbols 482
- mirroring wire numbers 1003
- MISC\_CAT tables 1271, 1294
- MISC1 attribute 2037
- miscellaneous attributes 331
- Missing Bill of Material Data Fields to Report dialog box 1380
- Missing Bill of Material reports
  - fields in 1380
  - formatting 1483
  - generating 1418
- missing catalog assignments 1304
- Missing Level/Sequence Assignments dialog box 1436
- Missing Level/Sequence Assignments reports
  - about 1428
  - fields in 1346
  - formatting 1452
  - generating 1436
- MNT files 182



- Modify Line Reference Numbers dialog box 968
  - Modify/Fix/Unfix dialog box 994
  - Module Box Dimensions dialog box 608
  - Module Layout dialog box 591
  - Module Specifications dialog box 616
  - modules
    - specification table 601
    - terminal information table 601
  - motion symbols 557–558
  - motor control circuits
    - customizing 2006
    - wire numbers 975
  - motor control symbols
    - 1-phase 487
    - 3-phase 489
    - DC motors 490
    - general 486
    - generators 491
    - illustrated 387
    - starters 492
    - tags in wire numbers 2059
  - motor starter symbols 492
  - motor symbol tags 2061
  - motors
    - 1-phase 487
    - 3-phase 489
    - database 711–712
    - DC motors 490
    - generators 491
    - starters 492
  - mount codes
    - copying 1584
    - mount code files 182
  - moving
    - attributes 798, 868
    - attributes to other layers 862–863
    - catalog files 1272
    - circuits 726
    - components 798, 801
    - descriptions 868
    - ladders 965
    - leaders with wire numbers 998
    - pins 1151
    - text to other layers 863
    - wire numbers 996–997, 999, 1003
  - mtext (multiline text)
    - editing 880
    - formatting wire annotations 1592
    - wire information 1587–1588
  - Multi-Connection Sequence Terminal symbols 1134
  - multi-connection terminals
    - about 1134
    - editing 1135, 1138
  - multi-level terminal strips 1078
  - multi-level terminals 1055
  - multi-stack terminals 1055
  - multi-tier terminals 1055
  - Multiple Bill of Material Information dialog box 755, 1303
  - multiple Bill of Materials 1303
  - multiple bus wiring 918, 1163
  - multiple cable markers 949, 1338
  - Multiple Cable Markers dialog box 949
  - Multiple Catalog Part Number Assignments dialog box 756, 1303
  - multiple catalogs 1273, 1303
  - multiple clients
    - about 190
    - libraries 191
    - project setup 192
    - sharing icon menus 1989
    - title blocks 190–191
    - Vault setup 2134
  - multiple connection terminals 320
  - multiple libraries 300–301
  - multiple part numbers 1578
  - Multiple Wire Bus dialog box 918
  - multipole circuits 2047, 2052
  - multipole terminal block units 1313
- ## N
- Nameplate reports
    - about 1428
    - fields in 1350
    - formatting 1456
    - generating 1439
  - nameplates
    - about 342, 1609

- creating 1610
- inserting 1609
- layers 264
- reports 1350, 1428, 1439, 1456
- stretchable 1610
- surfing references 1187
- naming conventions
  - attribute templates 2107
  - catalog tables 1271
  - circuit templates 2044
  - menus 1250
  - panel footprints 2105
  - schematic lookup files 782
  - symbols 282, 298, 2119
  - wire connections 2112
- navigating through drawings 1190
- NC contact state 809
- neon pilot lights 392
- network deployment 1989
- new circuits 2032
- new drawings 168
- New Module dialog box 611
- NEW\_DWG value 630
- next drawing command 1190
- NO contact state 809
- no wire numbering 28
- non-AutoCAD Electrical attributes 331
- non-intelligent ladders 966, 968
- non-text graphic layers 264
- normal wire numbers 970
- NULL contact values 813

## O

- OFF-delay timers 384
- older versions of files 129
- one-line circuits 27, 700, 703, 706
- one-line symbols 304, 329
  - creating 2098
  - naming conventions 298
- online help 3, 6
- opening drawings 1190
- opening tables 682
- operating devices 557
- Option - Tag Format Family Override
  - dialog box 759

- Optional ENV File Assignment for Current
  - Project dialog box 279
- Optional Script File Reference dialog
  - box 1322
- orientation
  - connectors 1157, 1174
  - pin annotations 1313
  - terminal strips 1130
- Orientation tab (Connector Selection
  - dialog box) 1174
- Orientation tab (Insert Connector dialog
  - box) 1157
- origin points 339
- overriding
  - cross-reference settings 815, 818–819
  - tags 759, 2125
  - wire types 275

## P

- P&ID drawing 1912
- P&ID drawings 1895
- p&id symbols 1916
  - ball mill 1916
  - conveyor 1917
  - dryer 1918
  - equipment 1916
  - field mounted instruments 1918
  - flow arrow down 1921
  - flow arrows 1921
  - gate valve 1918
  - mixer2 1917
- P&ID symbols
  - attributes 329
  - inserting 742, 1681
  - libraries 306
  - naming conventions 298
- page breaks in reports 1330
- Panel Balloon Setup dialog box 1602
- Panel Bill of Material Data Fields to Report
  - dialog box 1340
- Panel Bill of Materials dialog box 1432
- Panel Component Data Fields to Report
  - dialog box 1344
- Panel Component dialog box 1435

- Panel Component Exception Data Fields to Report dialog box 1342
- Panel Component Exception dialog box 1433
- Panel Component Layers dialog box 264
- panel component lists 794
- Panel Components dialog box 794
- Panel Drawing Configuration and Defaults dialog box 1529
- Panel Equipment In dialog box 1559
- Panel Footprint dialog box 1557
- Panel Footprint Lookup Database File Editor dialog box 1596
- panel footprints
  - attribute templates 1563
  - attributes 329, 1526
  - automatic updates 1532
  - catalog lookup tables 1294
  - configuration 1529
  - copying 1562
  - copying panel assemblies 1565
  - creating with Symbol Builder 2105
  - din rails 853
  - editing 1565, 1569, 1574
  - extracting footprint lists 790–791, 794–796
  - inserting 1536, 1538, 1540, 1542, 1552
  - inserting from catalogs 1555, 1557
  - inserting from equipment lists 1557–1559, 1561
  - inserting from icon menus 1544, 1548, 1551
  - inserting from vendor menus 1545, 1547
  - inserting manually 1551, 1555
  - inserting panel assemblies 1564
  - inserting with spreadsheet data 1537
  - layers 258
  - level assignments 1614, 1619, 1622
  - lookup files 182, 1534, 1594–1596, 1599
  - mapping 1534
  - naming conventions 298
  - reports 1428
  - sequencing assignments 1611, 1613
  - spacing 1544
  - symbols 342
  - wire information 1587–1588, 1590, 1592
  - Xdata 1527
- panel layers
  - renaming 258, 262
  - settings 258
- Panel Layout - Component Insert/Edit dialog box 1569
- Panel Layout - Terminal Insert/Edit dialog box 1574
- Panel Layout Data Export dialog box 1506
- Panel Layout List - Schematic Components Insert dialog box 791
- Panel Layout toolbar 108
- panel layouts
  - about 1523
  - automatic updates 1532
  - configuration 1527, 1529
  - editing 1565, 1569, 1574
  - exporting data 1506
  - footprint lookup files 1594
  - item number balloons 1600–1602
  - level assignments 1614, 1619, 1622
  - level/routing wire connections 1029
  - nameplates 342, 1609
  - naming conventions 298
  - relationships to schematic drawings 1534
  - reports 1428
  - resequencing item number balloons 1605
  - sequencing assignments 1611, 1613
  - surfing references 1187
  - tag lists 758
  - tagging 1657
  - templates 1563
  - tools 1524
  - wire annotation format 1531
  - Xdata 1526–1527
- panel lists
  - inserting components from 790–791, 794

- inserting terminals from 795–796
- Panel Missing Level/Sequence Assignments
  - Data Fields to Report dialog box 1346
- Panel Nameplate Data Fields to Report dialog box 1350
- Panel Nameplate dialog box 1439
- panel reports
  - about 1318, 1428
  - automatic generation 1496
  - bill of materials reports 1340, 1432, 1446
  - component exception reports 1342, 1433, 1448
  - component reports 1344, 1435, 1451
  - generating 1330, 1428, 1430
  - list of 1428
  - missing level/sequence assignments reports 1346, 1436, 1452
  - nameplate reports 1350, 1439, 1456
  - terminal exception reports 1352, 1440, 1458
  - types of 1428
  - wire annotation exception reports 1348, 1437, 1454
  - wire connection reports 1354, 1441, 1461
- Panel Tag List dialog box 758
- Panel Terminal Exception Data Fields to Report dialog box 1352
- Panel Terminal Exception dialog box 1440
- Panel Terminal List - Schematic Terminals Insert dialog box 795
- Panel Terminal Strip Graphical Report Parameters dialog box 1624
- Panel Terminals Data Export dialog box 1506
- Panel Terminals dialog box 796
- panel terminals lists 795
- Panel Wire Annotation Exception Data Fields to Report dialog box 1348
- Panel Wire Connection Data Fields to Report dialog box 1354
- Panel Wire Connection dialog box 1441
- panels
  - about 1523
  - automatic updates 1532
  - configuration 1527, 1529
  - editing 1565, 1569, 1574
  - exporting data 1506
  - footprint lookup files 1594
  - item number balloons 1600–1602
  - level assignments 1614, 1619, 1622
  - level/routing wire connections 1029
  - nameplates 342, 1609
  - naming conventions 298
  - panel assemblies 1563–1565
  - relationships to schematic drawings 1534
  - reports 1428
  - resequencing item number balloons 1605
  - schematic-to-panel terminal relationships 1055
  - sequencing assignments 1611, 1613
  - surfing references 1187
  - tag lists 758
  - tagging 1657
  - templates 1563
  - tools 1524
  - wire annotation format 1531
  - Xdata 1526–1527
- paralleled wires 720
- parameters
  - drawing properties 239
  - wire annotations 1590, 1592
  - wire numbers 990
  - wires 720
- parametric connectors 320
- parametric PLC modules 588, 590
- parametric twisted pair symbols
  - naming conventions 298
  - schematic attributes 320
- parent attributes 342
- parent cable markers 931, 939, 943, 945, 947
- parent location codes 882–883
- parent symbols
  - about 342

- creating 2090
  - schematic attributes 320
  - TAG1 attribute 321
- part catalogs 1271
- part numbers
  - assigning 1283, 1285, 1293
  - editing 1300
  - inserting 1300
  - multiple 755–756, 1578
  - multiple bill of materials 1303
  - sorting catalog databases by 1291
  - terminal catalog codes 1083
  - updating 883
- Parts Catalog dialog box 1291
- passing power 1670
- pasting database tables 682
- paths
  - file locations 182
  - libraries 300, 338
  - project files 187
  - signal paths 849
- PC3 (plotter configuration files) 1193
- PDS (Project Database Service) 1509
- PEER\_COILPINS field 1311, 1984
- PEER\_PINLIST field 1311, 1984
- peer-to-peer relationships 1981
- phase meter symbols 551
- phases 963
- photo eye switch symbols 415
- photoelectric emitter switch
  - symbols 530, 535
- photoelectric emitter-receiver switch
  - symbols 535
- photoelectric receiver switch
  - symbols 533, 535
- photosensitive electronic symbols 575
- physical representation block
  - symbols 1534
- Pick List for Panel Terminal Strip
  - Report/Graphical Report dialog box 1623
- pigtails 339
- pilot lights
  - beacon light symbols 502–503
  - general symbols 493
  - illustrated 390
  - LED symbols 500
  - master test pilot lights 391
  - neon pilot lights 392
  - push to test light symbols 497
  - standard light symbols 494
  - transformer light symbols 496
- pin charts 1330
- pin lists
  - about 1305
  - advanced techniques 1984
  - assignments 1313
  - editing 1306, 1309, 1311
  - pin numbers in use 1161
  - selecting 1307
  - special uses 1313
  - table structure 1309, 1311
  - type 4 pin combinations 1313
- pin numbers
  - editing 1152
  - exporting for Cable & Harness 1519
  - in-use 764, 1161
  - point-to-point wiring 1140
  - schematic attributes 320
  - swapping 1150
  - tracking changes to 1200
- Pin Numbers in Use dialog box 764
- pin tools 349
- PINLIST attribute 1305
- PINLIST database 1309
- PINLIST field 1311, 1984
- PINLIST\_TYPE attribute 1313
- pins
  - adding to connectors 1148
  - annotations 1313
  - child components 769, 773
  - component data 748, 753
  - in-use numbers 764
  - inserting 1157
  - moving 1151
  - naming conventions 298
  - pin assignments 1984
  - pin charts 1330
  - pin lists 1161, 1305–1307, 1309, 1311
  - pin tools 349
  - PLC I/O points 624

- PLC modules 596
- point-to-point wiring 1140
- reports 1330
- schematic attributes 320
- settings 1157
- spacing 1159, 1167
- swapping numbers 1150
- pipes 1900, 1919
- pipng & instrumentation 1912
- Piping and Instrumentation Diagram
  - symbols
    - inserting 742, 1681
    - libraries 306
    - naming conventions 298
    - symbol attributes 329
- pitch 1130
- PLC Component Connection Data Fields
  - to Report dialog box 1368
- PLC database
  - about 601
  - advanced techniques 2005
  - CATEGORY field 135, 620
  - contents 588, 630
  - DESCRIPTION field 135, 620
  - editing 606
  - generating drawings 630–631, 635, 639
  - migrating 129
  - Migration utility 135
  - PLC Database Migration utility 620
  - tables in 601
- PLC Database File Editor dialog
  - box 606, 2005
- PLC Database Migration utility 620
- PLC I/O Address and Descriptions Data
  - Fields to Report dialog
    - box 1386
- PLC I/O Address and Descriptions
  - reports
    - about 1402
    - fields in 1386, 1505
    - formatting 1486
    - generating 1420
- PLC I/O Address/Description Export dialog
  - box 1505
- PLC I/O Component Connection
  - reports
    - about 1402
    - fields in 1368
    - formatting 1469
    - generating 1409
- PLC I/O Connection Export dialog
  - box 1504
- PLC I/O Header Information Export dialog
  - box 1503
- PLC I/O modules
  - address and descriptions in
    - reports 1420, 1486
  - advanced techniques 2005
  - annotating points 622
  - AutoLISP routines 611
  - boxes 608, 614
  - component data in reports 1368
  - copying 602
  - creating 611
  - data fields in reports 1386
  - database 601, 630, 2005
  - editing 596, 616
  - editing symbols 620, 624
  - exporting address/description
    - data 1505
  - exporting header data 1503
  - exporting I/O connection data 1504
  - exporting Unity Pro data 652
  - full units 588
  - generating 588
  - generating drawings 630–631, 635, 639
  - I/O points 620, 624
  - importing Unity Pro data 645–646, 651
  - inserting 592
  - inserting AutoCAD blocks 611
  - inserting I/O points 621
  - line properties 608
  - migration utility 135, 620
  - module data 630
  - naming conventions 298
  - parametric symbols 588
  - PLC modules used so far in
    - reports 1390, 1423, 1493

- prompts 617
- reports 1402
- RSLogix data 640–642
- splitting 798, 802, 805
- spreadsheet format 630
- stand-alone points 620, 624
- stretching 798, 802
- styles 626
- symbol illustrations 394
- symbol schematic attributes 320
- symbols 320, 505
- terminals 603, 610, 613
- tracking changes to 1200
- wire numbers 977
- PLC I/O Wire Numbers dialog box 977
- PLC Modules Used So Far Data Fields to Report dialog box 1390
- PLC Modules Used So Far reports
  - about 1402
  - fields in 1390
  - formatting 1493
  - generating 1423
- PLC Parametric Selection dialog box 590
- PLC Selection dialog box 607
- PLCIO files 620
- plotter configuration files (PC3) 1193
- plotting 1191
- plug connectors
  - inserting 1157, 1167
  - plug/jack connector pin symbols 298
  - reports 1330, 1374, 1402, 1413, 1476
- plug/receptacle combinations 1157, 1167
- pneumatic components 742, 1671
- PNG files 1205–1206
- point-to-point schematics 1140
- point-to-point wiring tools
  - bending wires 1162
  - connector tools 1140
  - importing connector data 1175
  - importing data 1166–1167
  - multiple buses 1163
  - splices 1185
- post-processing reports 1330
- Power Check tools 117, 1668–1670
- power distribution blocks 399, 509
- power factor meter symbols 551
- power feed circuits 694, 696, 699–700, 703, 706
- power receptacles 427, 576
- power source symbols 570
- Power Source/Load Report dialog box 1670
- power sources
  - reports 1670
  - symbols 1668–1670
- power switches 459
- prefixes on signal arrows 1012
- pressure switches 410, 522
- pressure/current converter symbols 551
- previewing drawings 144
- previous drawing command 1190
- previous releases
  - migrating custom settings 131–132
  - migrating files 129
- printing reports 1330
- Project Database Service (PDS) 1509
- Project Database Table Data - Project Drawing Files Update dialog box 195
- project files
  - about 138
  - contents 187
  - settings in 202
- project label files 182
- Project Manager 1714, 1728, 1895, 1912
  - about 138, 154
  - Copy Project dialog box 156
  - creating projects 140
  - Define Layers dialog box 261
  - Drawing List Display Configuration dialog box 171, 174
  - Drawing List Report dialog box 192
  - Properties dialog box 206
  - Select Drawings to Process dialog box 196
  - switching projects 145
  - Task List dialog box 194
- Project Settings tab (Properties dialog box) 206, 2125

- Project Zip dialog box 188
- project-related files 182
- Project-wide Schematic Terminal
  - Renumber dialog box 1133
- project-wide tools
  - batch plotting 1191
  - marking changes 1200
  - moving between drawings 1190
  - Project-Wide Utilities dialog box 1195
  - publishing to the Web 1205–1207
  - renumbering ladders 1196
  - scripts 1195
  - surfing 1187
  - title blocks 1213, 1221
  - translating descriptions 1202–1203
  - updating and retagging 1199
- Project-Wide Update or Retag dialog box 1199
- Project-Wide Utilities dialog box 1195
- projects 1714, 1728, 1895, 1912
  - about 138
  - adding drawings 140
  - alternate environment settings 279
  - archiving 187–188
  - auditing 1686, 1688–1689, 1692, 1694
  - client setup 192
  - collaborative design 158
  - comparing settings 240–241
  - configuring for drawing
    - standards 2125, 2127
  - converting promis.e projects 1641
  - copying 142
  - copying catalog information 1283, 1300
  - creating 140
  - cross-references 815
  - database files 196
  - database table data 195
  - deleting 189
  - deleting drawings 144
  - descriptions 187, 204
  - file formats 187
  - fixed component tags 877–878
  - icon menu files 1260
  - managing drawings in 144
  - master files 158
  - multiple clients 190–191
  - previewing 144
  - project files 187
  - Project Manager 154
  - project-related files 182
  - project-wide utilities 1195
  - properties 202–203
  - recently opened 138
  - related files 182
  - resizing all text 873
  - saving settings 240–241
  - saving to web sites 1205–1207
  - script files 1195
  - surfing 1187
  - switching 145
  - task lists 194
  - terminal lists 1046
  - Vault and 158, 2134
  - versions of 2134
  - zipping 187
- promis.e conversion 1638–1639, 1641
- promis.e Conversion dialog box 1639
- prompts
  - missing 360
  - PLC modules 617
- Prompts at Module Insertion Time dialog box 617
- propagation flow or signal symbols 559
- properties
  - about 202–203
  - circuit icons 1257
  - command icons 1254
  - component icons 1252
  - copying 1058
  - din rails 853
  - drawings 202–203
  - icons 1234
  - imported Inventor data 1166–1167
  - line entities 853
  - mapping for export to Cable & Harness 1519
  - menus 1250
  - project-wide changes 1199
  - projects 202–203



- submenus 1259
- templates 245
- terminals 1046, 1053, 1060–1062, 1064, 1078
- wire numbers 979
- X zones 234
- X-Y grid 236
- Properties - Circuit dialog box 1257
- Properties - Command dialog box 1254
- Properties - Component dialog box 1252
- Properties - Main Menu dialog box 1250
- Properties - Submenu dialog box 1259
- Properties dialog box
  - Components tab 211
  - configuring for IEC standard 2125
  - Cross-References tab 216
  - Drawing Format tab 220
  - Project Settings tab 206
  - Styles tab 218
  - Wire Numbers tab 215
- proximity switches
  - capacitive switch symbols 526
  - illustrated 415
  - inductive switch symbols 524
  - magnetic switch symbols 528
  - photoelectric emitter switch symbols 530, 535
  - photoelectric emitter-receiver switch symbols 535
  - photoelectric receiver switch symbols 533, 535
  - touch switch symbols 539
  - ultrasonic switch symbols 537
- Publish to Web - Temporary Folder for Build dialog box 1206
- publishing
  - drawing files as HTML 1205–1206
  - options 1207
- pull cord switch symbols 415, 545
- purging unused items 1688
- push buttons 366, 441–442
- push to test light symbols 497
- pyrometer symbols 551

## Q

- qualifying symbols
  - effect symbols 560
  - energy flow symbols 560
  - fault symbols 562
  - linear direction of force or motion 557
  - mechanical controls symbols 566–568
  - operating devices 557
  - propagation flow or signal symbols 559
  - radiation symbols 561
  - rotative direction of force or motion 558
  - winding symbols 565
- quick relay coil symbols 482

## R

- radiation symbols 561
- RATING field 1279
- ratings
  - child components 769, 773
  - component data 748, 753
  - entering values 807–808
  - PLC I/O points 624
  - ratings defaults files 182
  - terminals 1046
  - tools 349
  - updating 883
- Ratings Defaults dialog box 808
- RC network symbols 575
- reactors 463
- real time error checking files 182
- Reassign Terminal dialog box 1101
- reassigning terminals 1101
- Rebuild Database File dialog box 196
- rebuilding databases 196
- rebuilding terminal strips 1093, 1119
- receptacle connectors 1157, 1167
- recording wattmeter symbols 551
- records
  - adding 685, 780
  - catalog structure 1277

- editing 685, 780, 782
  - editing footprint lookup files 1596, 1599
  - editing in catalogs 1298
  - schematic lookup files 782, 785
  - terminal properties 1060, 1064
  - user data 854–855
- Ref Des (tags) 748
- referencing
  - arrow symbols 431, 580
  - existing circuits 724
  - format settings 220, 233
  - WD\_M block attributes 253
- refreshing terminal strips 1093, 1119
- relationships 1055, 1057
- relays
  - counter relay symbols 481
  - current protection relay
    - symbols 479
  - general symbols 476, 482
  - illustrated 379, 382
  - relays with suppression symbols 477
  - sensing lack of phase 482
  - time delay relay symbols 485
  - voltage protection relay
    - symbols 480
- relays with suppression symbols 477
- Remove Component Override dialog box 819
- removing
  - components 798–799, 1585
  - database tables 683
  - drawings 144
  - footprints 1585
  - jumpers 1109
  - location mark symbols 885
  - marker blocks 2037
  - pins from connectors 1149
  - projects 189
  - sequencing 1611
  - tracking deleted objects 1200
  - wire gaps 958
  - wire numbers 1010
- Rename Panel Layers dialog box 262
- Rename Schematic Layers dialog box 262
- renaming
  - attributes 875
  - layers 258, 262
  - menus 1250
- Renumber Ladders dialog box 969
- Renumber Terminal Strip dialog box 1102
- renumbering
  - ladders 963, 969
  - terminal strips 1102
  - terminals 1133
- reordering drawings 144
- repairing wire gaps 1689
- replaceable parameters 239
- replacing
  - blocks using spreadsheet data 1663–1665
  - text 864–867
  - WD\_M blocks 255
  - wire number text 986–987
- Report Format File Setup - Missing Level/Sequence Assignments dialog box 1452
- Report Format File Setup - Panel Bill of Material dialog box 1446
- Report Format File Setup - Panel Component dialog box 1451
- Report Format File Setup - Panel Component Exception dialog box 1448
- Report Format File Setup - Panel Nameplate dialog box 1456
- Report Format File Setup - Panel Terminal Exception dialog box 1458
- Report Format File Setup - Panel Wire Connection dialog box 1461
- Report Format File Setup - Schematic Bill of Material dialog box 1463
- Report Format File Setup - Schematic Cable From/To dialog box 1465
- Report Format File Setup - Schematic Cable Summary dialog box 1467
- Report Format File Setup - Schematic Component dialog box 1480

- Report Format File Setup - Schematic Component Wire List dialog box 1471
- Report Format File Setup - Schematic Connector Details dialog box 1474
- Report Format File Setup - Schematic Connector Plug dialog box 1476
- Report Format File Setup - Schematic Connector Summary dialog box 1478
- Report Format File Setup - Schematic Missing Bill of Material dialog box 1483
- Report Format File Setup - Schematic PLC I/O Address and Descriptions dialog box 1486
- Report Format File Setup - Schematic PLC I/O Component Connection dialog box 1469
- Report Format File Setup - Schematic PLC Modules Used So Far dialog box 1493
- Report Format File Setup - Schematic Terminal Numbers dialog box 1489
- Report Format File Setup - Schematic Terminal Plan dialog box 1491
- Report Format File Setup - Schematic Wire From/To dialog box 1484
- Report Format File Setup - Schematic Wire Label dialog box 1495
- Report Format File Setup - Wire Annotation Exception dialog box 1454
- report format files 1442, 1444
- reports
  - about 1318
  - automatic 1496–1497, 1499
  - change-tracking reports 1202
  - conduit markers 1634–1635
  - conduit routing reports 1636
  - cross-references 809
  - drawing lists 192
  - editing 1323
  - exception/error reports 809
  - exporting for Cable & Harness 1519, 1521–1522
  - filtering 1318
  - format files 1442, 1444
  - from/to reports 1029
  - generating 1330, 1403
  - grouping 1496
  - inserting in drawings 1330
  - missing catalog assignments 1304
  - panel reports 1428, 1430
  - power check reports 1670
  - printing 1330
  - resizing 1330
  - running 1496–1497, 1499
  - saving 1330
  - saving to script files 1322
  - schematic reports 1402–1403
  - settings 1330
  - settings lists 241, 243
  - sorting 1330
  - stand-alone reference code reports 1019
  - surfing 812
  - table setup 1322
  - terminal pick lists 1623
  - terminal strip tables 1070, 1624
  - types of 1402
  - updating configurations 244
  - wildcard characters 1318
  - wire signal reports 1019
- Resequence Panel Item Numbers dialog box 1605
- resequencing
  - item number balloons 1604–1605
  - terminal numbers 1133
- resistors 426, 575
- resizing
  - ladders 964
  - reports 1330
  - text 873–874, 893
  - wire numbers 1008
  - wires 921
- Retag Components dialog box 879
- retagging
  - components 879

- project-wide changes 1199
- reusing circuits 735
- Reverse/Flip Component dialog box 806
- reversing
  - components 805–806
  - connectors 1142, 1144
- reviewing drawing sets 1200
- RGF files 1496
- ribbon
  - about 25, 117
  - Conduit Marker tools 116
  - Conversion tools 115
  - displaying and organizing 118
  - Extra Library tools 117
  - Main Electrical tools 94, 104
  - Panel Layout tools 108
  - Power Check tools 117
- right angle bends 922
- rolling back projects 2134
- rotating
  - attributes 870
  - connectors 1142–1143
  - terminal strips 1130
  - wire numbers 997, 1008
- rotating beacon light symbols 503
- rotative direction symbols 558
- routing
  - copying 1614
  - displaying 1611
  - editing 1613
  - removing 1611
  - wire conduit routing data in
    - reports 1396
- routing reports 1396, 1636
- rows
  - report tables 1322
  - row styles 1110
- RSLogix
  - exporting PLC spreadsheets 640–642
  - importing files 182
- RSLogix 500 Import Change Module dialog box 642
- RSLogix 500 Import dialog box 641
- ruling (terminal strips) 1130

- rungs
  - inserting 966
  - spacing 963, 965, 968
- running
  - automatic reports 1496
  - reports 1318, 1497, 1499
  - scripts 1195

## S

- sandbox guidelines 2134
- Save Circuit to Icon Menu dialog box 735
- Save Symbol dialog box 359
- saving
  - circuits 728, 735
  - custom settings 132
  - DWF files 1208
  - project settings 240–241
  - reports 1330
  - symbols 357, 359
  - web formats 1205–1207
- scale
  - conduit markers 1631
  - format settings 220, 233
  - PLC modules 590
  - text 893
- Schematic Bill of Material dialog box 1405
- Schematic Cable From/To dialog box 1407
- Schematic Cable Summary dialog box 1407
- Schematic Component dialog box 778, 1416
- Schematic Component Wire List dialog box 1410
- Schematic Components List Panel Layout Insert dialog box 1538
- Schematic Components or Terminals dialog box 1542
- Schematic Connector Details dialog box 1412
- Schematic Connector Plug dialog box 1413

- Schematic Connector Summary dialog
  - box 1415
- Schematic Database File Editor 784–785
- schematic diagrams
  - attributes 320
  - auditing 1686, 1688–1689, 1692, 1694
  - automatic updates 1532
  - generating from PLC I/O
    - modules 630–631, 635, 639
  - inserting panel footprints 1538, 1542
  - inserting terminals 1540, 1542
  - ladder diagrams 1140, 1534
  - layers 258
  - panel component spreadsheet
    - data 1536–1537
  - point-to-point 1140
  - relationship to panel layouts 1534
  - reports 1428
  - showing links 1661
  - tagging 1656
  - wire connections 1029
- Schematic Equipment In dialog box 789
- schematic layers
  - renaming 258, 262
  - settings 258
- Schematic Layout Wire Connection
  - Annotation dialog box 1592
- schematic lookup files
  - about 782
  - editing 782, 784–785
  - inserting components 789
  - location 182
- Schematic Missing Bill of Material dialog
  - box 1418
- Schematic PLC I/O Address and
  - Descriptions dialog box 1420
- Schematic PLC I/O Component
  - Connection dialog box 1409
- Schematic PLC Modules Used So Far dialog
  - box 1423
- Schematic Report dialog box 1935, 1937
- schematic reports
  - about 1318, 1402
  - automatic generation 1496
  - bill of materials reports 1356, 1405, 1463
  - cable from/to reports 1363, 1407, 1465
  - cable label reports 1364
  - cable summary reports 1358, 1407, 1467
  - component reports 1378, 1416, 1480
  - connection sequencing reports 1029
  - connector data 1372
  - connector details reports 1412, 1474
  - connector plug reports 1374, 1413, 1476
  - connector summary reports 1376, 1415, 1478
  - cross-reference data 1397, 1399
  - generating 1330, 1402
  - list of 1402
  - location codes in from/to
    - reports 1427
  - missing bill of material
    - reports 1380, 1418, 1483
  - PLC connection reports 1368, 1386, 1409, 1469
  - PLC I/O address and descriptions
    - reports 1420, 1486
  - PLC modules used so far
    - reports 1390, 1423, 1493
  - terminal numbers reports 1388, 1421, 1489
  - terminal plan reports 1393, 1422, 1491
  - types of 1402
  - wire conduit routing data 1396
  - wire from/to reports 1384, 1419, 1484
  - wire label reports 1394, 1425, 1495
  - wire list reports 1370, 1410, 1471
- schematic symbols
  - attributes 320
  - child symbols 342
  - inserting 742
  - parent symbols 342
  - terminal symbols 342

- Schematic Terminal Numbers dialog
  - box 1421
- Schematic Terminal Plan dialog
  - box 1422
- Schematic Terminals List Panel Layout
  - Insert dialog box 1540
- Schematic Wire From/To dialog
  - box 1419
- Schematic Wire Label dialog box 1425
- Schematic Wire Numbers Panel Wiring
  - Diagram dialog box 1590
- schematic-to-panel terminal
  - relationships 1055
- schematic-to-schematic terminal
  - relationships 1055
- schematics
  - attributes 320
  - auditing 1686, 1688–1689, 1692, 1694
  - automatic updates 1532
  - generating from PLC I/O
    - modules 630–631, 635, 639
  - inserting panel footprints
    - with 1538, 1542
  - inserting terminals with 1540, 1542
  - ladder diagrams 1140, 1534
  - layers 258
  - panel component spreadsheet
    - data 1536–1537
  - point-to-point 1140
  - relationship to panel layouts 1534
  - reports 1428
  - showing links 1661
  - tagging 1656
  - wire connections 1029
- scooting
  - components 798, 800
  - connectors 1140
  - wire numbers 996
  - wires 798, 800, 1140
- SCR symbols 575
- scratch databases 195
- Script File Options Reference dialog
  - box 1322
- scripts
  - adding icons for 1242
  - batch plotting 1193
  - project-wide scripts 1195
  - saving reports to script files 1322
- search paths
  - file locations 182
  - libraries 300
- searching
  - finding wire number text 986–987
  - terminal properties database 1060
  - text 864–867
- sections in report tables 1322
- Select Circuit dialog box 710, 712
- Select Color dialog box 1901, 1914
- Select Description from AutoCAD Electrical
  - Language Table dialog box 762–763
- Select Description Text Format dialog
  - box 763
- Select Drawings to Process dialog
  - box 196
- Select Linetype dialog box 1901, 1914
- Select Linetypes File dialog box 1915
- Select Lineweight dialog box 1914
- Select Load dialog box 712
- Select Motor dialog box 711
- Select Pin List Table dialog box 1307
- Select Row Cell Styles dialog box 1110
- Select Symbol/Objects dialog box 344
- Select Terminal Information dialog
  - box 610
- Select Terminal Properties Table dialog
  - box 1061
- Select Terminals to Jumper dialog
  - box 1125
- Select Xdata to Change to a Block Attribute
  - dialog box 1527
- selector switches 370, 374, 445, 450, 452
- sensors 551
- sequence assignments
  - missing 1346, 1428, 1436, 1452
  - reports 1428, 1436, 1452
- sequencing
  - about 1029
  - displaying 1031, 1611
  - editing 1030, 1037, 1613
  - removing 1611

- resequencing item numbers 1605
- tee markers 1033–1034
- sequential codes 1303
- SET files
  - about 1442
  - defining 1444
  - missing level/sequence assignments reports 1452
  - panel bill of materials reports 1446
  - panel component exception reports 1448
  - panel component reports 1451
  - panel nameplate reports 1456
  - panel terminal exception reports 1458
  - panel wire annotation exception reports 1454
  - panel wire connection reports 1461
  - schematic bill of material reports 1463
  - schematic cable from/to reports 1465
  - schematic cable summary reports 1467
  - schematic component reports 1480
  - schematic component wire list reports 1471
  - schematic connector details reports 1474
  - schematic connector plug reports 1476
  - schematic connector summary reports 1478
  - schematic missing bill of material reports 1483
  - schematic PLC I/O address and descriptions reports 1486
  - schematic PLC I/O component connection reports 1469
  - schematic PLC used so far reports 1493
  - schematic terminal numbers reports 1489
  - schematic terminal plan reports 1491
  - schematic wire from/to reports 1484
  - schematic wire label reports 1495
- Set Pass Power dialog box 1670
- Set Power Source/Load Value dialog box 1669
- Set Wire Type dialog box 278
- Settings dialog box 787, 1561
- Settings List Utility
  - about 241
  - configuration updates 244
  - editing reports 243
- shapes 1551
- sharing
  - files 1989
  - Vault guidelines 2134
- sheets
  - project-wide changes 1199
  - settings 222
- shields (cable) 956
- Show Link tool 1661
- shunt symbols 575
- Signal - Source Code dialog box 1015
- signal arrow symbols
  - about 1011
  - inserting 1014–1015
  - naming conventions 298
  - prefixes 1012
  - project-wide changes 1195
  - styles 1012, 1016, 1018
- Signal Code dialog box 849
- signals
  - arrows 298, 1011
  - destination 848–849
  - fanning markers 1024–1026
  - following 848–849
  - project-wide changes 1199
  - schematic symbol attributes 320
  - source 848–849
  - symbol naming conventions 298
  - symbols 559
  - updating 845
- single pole double throw switches 418
- single receptacle symbols 427, 576
- single side connectors 403, 407
- siren symbols 570
- size
  - connectors 1157, 1167

- text size 873–874, 893
- wires 720–721
- Size tab (Connector Selection dialog box) 1174
- Size tab (Insert Connector dialog box) 1157
- SKIP value 630
- solenoids 419, 547
- sorting
  - database tables 685
- sorting reports 1330
- source arrows 1647
- source codes
  - source code lists 1019
  - tracking changes to 1200
- source cross-reference symbols 809, 844–845
- source markers
  - adding 1021
  - advanced techniques 1996
  - fanning 1020
  - layers 1022–1024, 1026
  - styles 1022–1024
- source wire signal symbols 298, 320, 1011–1012, 1015, 1647
- SPACER value 630
- spacers 1159, 1167
- spacing
  - buses 918, 2053
  - fixed spacing 1142
  - inserted items 1544
  - ladders 960, 963
  - pins 1159, 1167
  - PLC database information 601
  - PLC modules 591, 606, 610
  - rungs 965, 968
- Spacing for Component or Footprint Insertion dialog box 1544
- spare connectors 403, 407
- spare terminal strips 1103
- spare terminals 1078, 1103
- spare wires 1632
- Special Explode dialog box 1654
- special wire numbers 975
- splice symbols
  - exporting data for Cable & Harness 1519
  - illustrated 423, 580
  - importing occurrences from Inventor 1166–1167
  - inserting 1185
  - naming conventions 298
  - schematic attributes 320
- Split Block dialog box 805
- Split Connector dialog box 805
- splitting
  - blocks 798, 802, 805
  - components 798, 802, 805
  - connectors 798, 802, 805, 1147
  - tag names 299
  - terminal tables 1070
- Spreadsheet to PLC I/O utility 135, 182, 620, 635
- Spreadsheet to PLC I/O Utility Setup dialog box 639
- spreadsheets
  - din rails 853
  - exporting component data 1502
  - exporting data to 1500–1501, 1503
  - exporting panel layout data 1506
  - exporting PLC data 1503–1505
  - exporting terminal data 1506–1507
  - importing connector data 1175
  - importing data from 1500
  - mapping to blocks 1663–1665
  - PLC database content 630
  - reports 1318
  - RSLogix data 640–642
  - structure 1175
  - updating drawings with data 1508
- squeezing
  - reports 1330
  - text 873
- Stand-Alone Destination Cross-Reference Symbol dialog box 844
- stand-alone I/O points 620
- Stand-Alone Source Cross-Reference Symbol dialog box 844



- stand-alone symbols
  - cross-reference symbols 430, 579, 838–839, 844–845
  - inserting 742
  - naming conventions 298
  - PLC 620
  - schematic attributes 320
  - TAG1 attribute 321
- standard light symbols 494
- standards 681, 687, 2044, 2125, 2127
- stretching
  - components 798, 802
  - connectors 1146
  - nameplates 1610
  - text 873
  - wires 921, 2082
- Style Box Dimensions dialog box 614
- styles
  - attribute text 871
  - drawing properties 202
  - fanning markers 1022–1025
  - PLC database information 601
  - PLC modules 590, 614, 626
  - project properties 202
  - project-wide changes 1195
  - settings 218, 231
  - signal arrows 1012
  - sorting catalog databases by 1291
  - table row styles 1110
  - WD\_M block attributes 253
- Styles tab (Drawing Properties dialog box) 231
- Styles tab (Properties dialog box) 218, 2125
- subcatalog entries 1330
- submenus
  - creating 1249
  - editing 1264
  - properties 1259
- support files 1989
- suppressor symbols 423
- Surf dialog box 1189, 1944
- surfing
  - codes 1189
  - continuing surf sessions 1187
  - cross-reference reports 812
  - references in drawing sets 1187
  - web pages 1207
- Swap Block/Update Block/Library Swap dialog box 336
- swapping
  - blocks 332–333, 336–338
  - libraries 337
  - NO/NC state 809
  - pin numbers 1150
  - terminal strip text 1612
  - wire numbers 999
- switches
  - component data 748
  - symbols 415, 545
- switching
  - blocks 332–333, 336–338
  - contact states 809
  - drawing standards 2127
  - pin numbers 1150
  - terminal strip text 1612
  - wire numbers 999
  - wire types 275, 277
- Symbol Audit dialog box 360
- Symbol Builder
  - about 342, 2083
  - attributes 346, 349, 2107
  - auditing symbols 360
  - configuring symbols 345
  - converting non-Electrical objects 2099
  - converting text to attributes 355–356
  - creating footprints 2105
  - creating symbols 342, 344
  - editing symbols 350
  - inserting symbols 350
  - link line attributes 354
  - one-line symbols 2098
  - parent symbols 2090
  - saving symbols 357, 359
  - templates 2107
  - terminal symbols 2094
  - wire connections 351, 353, 2112
- Symbol Builder Attribute Editor 349
- Symbol Configuration dialog box 345
- symbol libraries 300

- Symbol Library Attribute Text/Scale Resize dialog box 893
- symbol mapping
  - cross-references 827, 830
  - editing tables 832
- Symbol Preview window 1237
- symbols
  - adding to icon menus 1232, 2119
  - advanced techniques 2083
  - attributes 345, 349
  - auditing 357, 360
  - changing appearance 331
  - converting non-Electrical blocks 1642, 1644, 2099
  - COPYTAG attribute 329
  - creating 339, 342, 344
  - cross-references 809, 838–839, 844–845
  - customizing icon menus 1232, 1234, 1237
  - default libraries 300–301
  - editing attributes 349, 893
  - family types 298
  - layers and 331
  - location mark symbols 885, 887
  - multiple libraries 300–301
  - naming conventions 282, 298
  - one line symbols 329
  - one-line symbols 2098
  - parent symbols 2090
  - predefined annotations 332
  - saving 357, 359
  - schematic attributes 320, 342
  - splitting tag names 299
  - substituting 330
  - surfing 1187
  - swapping blocks 332–333, 336–338
  - Symbol Builder 342, 2083
  - TAG1 attribute 321
  - TAG2 attribute 321
  - types 342
  - updating blocks 332–333, 336–338
  - WD\_M blocks 253
- synchronizing files during migration 131
- synchronoscope symbols 551

## T

- Table Cross-Reference Format Setup dialog box 830
- Table Generation Setup dialog box 1322
- tables (cross-references)
  - cross-reference data 817
  - editing 832
  - graphical formats 822, 824, 827
  - report fields 1399
  - table formats 830
  - updating 833
- tables (database)
  - catalog tables 1271, 1295
  - copying 682
  - deleting 683
  - editing 685
  - footprint lookup files 1594
  - opening 682
  - pin lists 1306–1307, 1309, 1311
  - PLC database tables 601
  - schematic lookup files 784–785
  - scratch databases 195
  - terminal properties database 1060–1062, 1064
  - user data 854–855
- tables (reports)
  - breaking into sections 1318
  - setup 1322
- tables (terminal strips)
  - fields in 1113
  - generating 1113, 1119
  - inserting 1070, 1114
  - layout 1093
  - row styles 1110
  - settings 1096
- tabular terminal layout 1093
- tachometer symbols 551
- tachometric dynamo symbols 551
- tag panel components 1942
- Tag Panel tools 1657
- Tag Schematic tools 1656
- tag strips 1065
- TAG1 attribute 321
- TAG1\_PARTX 299
- TAG2 attribute 321

- TAG2\_PARTX 299
- tagging non-Electrical-aware
  - objects 1651, 1653, 1656–1657, 1659
- tagging tools 1932
- tags
  - cable markers 939, 943, 945, 947
  - cables 953
  - child components 769, 773
  - circuits 2068
  - codes for replaceable
    - parameters 239
  - components 748, 753
  - conduits 1626, 1631
  - copying attributes 329
  - cross-references and 809
  - duplicate 1686, 1688, 1692, 1694
  - exporting for Cable & Harness 1519
  - fixed component tags 877–878
  - in-use 757–758
  - motor symbol tags 2061
  - motor symbols 2059
  - multi-connection sequences 1138
  - order settings 220, 233
  - overriding 759, 2125
  - panel drawings 758
  - parameters 990
  - PLC database information 630
  - PLC I/O points 624
  - PLC modules 596
  - project-wide changes 1195, 1199
  - retagging components 866, 879
  - splitting names 299
  - terminals 1046
  - tracking changes to 1200
  - WD\_M block attributes 253
  - wire tags 970, 972–973
- Tags in Use dialog box 757
- target attributes 1587–1588
- Task List dialog box 194
- tees
  - connection symbols 1033–1034
  - export mapping 1519
- temperature switches 410, 522
- templates
  - attribute templates 342, 2107
  - creating 245
  - ladders and 960
  - panel layouts 1563
  - PLC-generated drawings 639
  - reports 1318
  - Symbol Builder 2107
  - wire connection templates 351
- Terminal Block Properties dialog
  - box 1053
- Terminal Block Settings dialog box 613
- terminal blocks 1053, 1542
- terminal boxes 2005
- Terminal Data Export dialog box 1507
- Terminal Exception reports
  - about 1428
  - formatting 1458
  - generating 1440
- terminal numbers
  - renumbering 1133
  - reports 1388, 1402, 1421, 1489
- Terminal Numbers Data Fields to Report
  - dialog box 1388
- Terminal Numbers reports
  - about 1402
  - fields in 1388
  - formatting 1489
  - generating 1421
- Terminal Plan Data Fields to Report dialog
  - box 1393
- Terminal Plan reports
  - about 1402
  - fields in 1393
  - formatting 1491
  - generating 1422
  - internal and external codes 1330
- Terminal Properties Database Editor
  - about 1060
  - Edit dialog box 1062
  - Edit Record dialog box 1064
  - editing properties 1060
  - Select Terminal Properties Table dialog
    - box 1061
- terminal row styles 1110
- Terminal Strip Definition dialog
  - box 1073

- Terminal Strip Editor
  - about 1065
  - accessories 1104
  - Cable Information tab 1087
  - Catalog Code Assignment tab 1083
  - columns and rows 1093
  - Edit Terminal dialog box 1100
  - inserting terminal strip tables 1070
  - inserting terminal strips 1066
  - installation codes 1106
  - jumper charts 1071
  - Layout Preview tab dialog box 1093
  - location codes 1105
  - previewing terminal strips 1093
  - selecting terminal strips 1068
  - spare terminals 1103
  - Terminal Strip Definition dialog box 1073
  - Terminal Strip Selection dialog box 1072
  - Terminal Strip tab 1078
  - Terminal Strip Table dialog box 1113
  - wire constraints 1078
- Terminal Strip Representation - Setup dialog box 1130
- Terminal Strip Representation dialog box 1129
- Terminal Strip Selection dialog box 1072
- Terminal Strip tab (Terminal Strip Editor) 1078
- Terminal Strip Table Data Fields to Include dialog box 1113
- Terminal Strip Table dialog box 1113
- Terminal Strip Table Generator
  - generating tables 1113
  - inserting terminal strip tables 1070
  - settings 1119
  - Terminal Strip Table Settings dialog box 1096
- Terminal Strip Table Settings dialog box 1096
- terminal strips
  - about 1128
  - accessories 1104
  - annotations 1130
- associating 1108
- catalog codes 1083
- defining 1073
- displaying 1129
- drawing shapes 1551
- editing 1078, 1100, 1128
- graphical layout 1093
- inserting 1066, 1615
- inserting reports as 1330
- inserting tables 1114
- installation codes 1106
- jumper assignments 1070
- jumper charts 1071, 1093
- level assignments 1614, 1619, 1622
- location codes 1105
- multi-level 1078
- parameters 1624
- pick lists 1623
- previewing layout 1093
- reassigning terminals 1101
- renumbering 1102
- reports 1623–1624
- row styles 1110
- selecting 1068, 1072
- sequencing assignments 1611, 1613–1614
- settings 1130
- spare terminals 1103
- swapping text 1612
- table fields 1113
- table rows 1110
- tables 1070, 1093, 1096, 1113–1114, 1119
- terminal associations 1108
- Terminal Strip Editor 1065
- terminals
  - about 342
  - accessories 1104
  - annotations 1130
  - assigning types 2005
  - associations 1046, 1050, 1055, 1057, 1078, 1108
  - attributes 320, 329, 2005
  - breaking associations 1055, 1057
  - cable information 1087
  - connections 1132

- copying properties 1058
- customized symbols 2094
- device box symbols 428, 577
- direct-to-terminal wire
  - connections 1029
- displaying associations 1055
- editing 606, 1046, 1053, 1100, 1565, 1569, 1574
- editing blocks 2005
- editing database 1060
- exceptions in reports 1352
- exporting data 1506–1507
- inserting 1040, 1046, 1542
- inserting from panel lists 790, 795–796
- inserting terminal reports as
  - strips 1330
- jumper charts 1071
- jumpers 1078, 1122–1123, 1125, 1127
- level assignments 1614
- listing 1078
- marking 1132
- multi-connection 1134–1135, 1138
- multi-level terminals 1055
- multi-stack terminals 1055
- multi-tier terminals 1055
- multipole terminal block units 1313
- naming conventions 298
- panel footprint spreadsheet
  - data 1536–1537
- panel terminal spreadsheet
  - lists 1540
- parameters 1624
- pick lists 1623
- pin lists 1305–1307, 1309, 1311
- PLC database information 601
- PLC modules 603, 610, 613
- previewing layout 1093
- project lists 1046
- properties 1046, 1053, 1078
- properties database 1060–1062, 1064
- reassigning 1101
- relationships 1055
- reports 1402, 1422, 1428, 1440, 1458, 1491, 1623–1624
- sequencing assignments 1611, 1613
- spacing 1544
- spare 1078, 1103
- surfing 1187
- symbols 339, 397, 508, 1040
- tags 1046
- terminal grid 606
- terminal numbers 1133, 1388, 1421, 1489
- terminal plan reports 1393, 1422, 1491
- Terminal Strip Editor 1065
- terminal strip tables 1070
- terminal strips 1128–1130, 1615, 1619
- text 866–867
- tracking changes to pin
  - numbers 1200
- types of 342, 1040, 1046
- Unity Pro data 651
- TERMPROPS tables 1060
- testing
  - circuits 2043
- text
  - annotation files 760
  - converting non-Electrical objects 2099
  - converting to attributes 355–356, 1645
  - converting to entities 1651, 1653, 1656–1657, 1659
  - converting to wire numbers 1646
  - cross-references 820
  - descriptions 763, 868
  - editing 864–867
  - finding 864–867, 986–987
  - justification 870–871
  - layers 863
  - library symbols 893
  - multi-line 880
  - project-wide changes 1195
  - replacing 864–867, 986–987
  - report tables 1322
  - resizing 893

- size 873–874
  - styles 871
  - swapping wire text 1612
  - terminal strips 1130
  - terminals 866–867
  - title blocks 1224
  - tracking changes to 1200
  - translating descriptions 1202–1203
  - wire annotations 1531, 1587–1588
  - wire numbers 986–987
  - Text Cross-Reference Format Setup dialog box 820
  - text files
    - external component lists 182
    - importing annotations from 760
  - text styles 871
  - TEXTVALUES 1277
  - thermal effect symbols 560
  - thermocouple symbols 421, 551
  - thermometer symbols 551
  - time delay relays 382, 485
  - timers 382, 384
  - title blocks
    - about 1213, 1221
    - attributes 1213, 1221
    - client-specific 190–191
    - embedded information in 1213
    - labels 191
    - linking information to 1213, 1708
    - mapping 1218, 1220
    - mapping AutoLISP values to 1227
    - multiple title blocks 1213, 1221
    - project-wide updates 1199, 1221
    - settings 1213, 1221
    - updating 1221, 1224
    - wildcard characters 1213, 1221
  - titles
    - report tables 1322
    - web pages 1207
  - Toggle Installation Codes dialog box 1106
  - Toggle Location Codes dialog box 1105
  - toggle switch symbols 415
  - toggling
    - installation codes 1106
    - location codes 1105
  - tee markers 1034
  - wire numbers 1003
  - toolbars
    - Conduit Marker 116
    - Conversion 115
    - Extra Libraries 117
    - Main Electrical 94, 104
    - Panel Layout 108
    - Power Check 117
    - Ribbon interface 25
  - touch switch symbols 539
  - trace mode
    - auditing drawings 1688
    - repairing drawings 1689
  - tracking changes 1200
  - transformer light symbols 496
  - transformers 376, 467, 469, 473
  - translating descriptions 1202–1203
  - Trim Wire dialog box 920
  - trimming wires 919–920, 2050
  - troubleshooting
    - auditing drawings 1686, 1688–1689, 1692, 1694
    - real-time error checking 1686, 1688–1689, 1692, 1694
    - wire numbers 978
    - zooming extents 919
  - turns 922
  - twisted pair symbols
    - naming conventions 298
    - schematic attributes 320
    - twisted pair cable symbols 427, 576
  - TXT files
    - external component lists 182
    - importing annotations from 760
  - TYPE field 1279
  - Type tab (Connector Selection dialog box) 1174
  - Type tab (Insert Connector dialog box) 1157
- ## U
- ultrasonic switch symbols 537
  - unavailable files 198
  - unfixed component tags 878

- unfixed wire numbers 994
- units of measurement 1303
- Unity Pro
  - exporting PLC data 645–646, 651
  - importing PLC data 652
- Unity Pro Export dialog box 652
- Unity Pro Import dialog box 651
- unlinking symbols 1661
- Update Block - Path/File name dialog box 338
- Update Configuration Changes dialog 244
- Update Drawings per Spreadsheet Data dialog box 1508
- Update Title Block dialog box 1224
- Update Wire Signal and Stand-Alone Cross-Reference dialog box 845
- updating
  - annotations 839
  - blocks 332–333, 336–338
  - cable markers 953
  - child location codes 882–883
  - cross-reference tables 833
  - drawings 196
  - drawings with imported data 1500
  - IEC tags 193
  - older versions of files 129
  - project-wide changes 1199
  - stand-alone cross-reference symbols 845
  - task lists 194
  - terminal strips 1093
  - title blocks 1221, 1224
  - WD\_M blocks 255
  - wire signals 845
- User-Defined Attribute List dialog box 1512
- user-defined attributes 1509–1510, 1512
- user-defined symbols 298
- users
  - multiple users 1989
  - user data in project databases 854–855
  - Vault capabilities 2134
- utilities
  - Setting List Utility 241, 243–244

- zip utility 187–188

## V

- valves 421
- variable resistors 426, 575
- varistor symbols 575
- varmeter symbols 551
- Vault
  - advanced techniques 2134
  - collaborative design and 158
- vendor icon menus 1544–1545, 1547
- Vendor Menu Selection dialog box 1545
- Vendor Panel Footprint dialog box 1547
- verifying changes 1200
- versions of projects 2134
- vertical ribbon 118
- vertical wire numbers 1008
- VIA drawings 1648, 1650
- View/Edit Panel Component Connection Sequence dialog box 1613
- volt meters 421
- voltage drops 720
- voltage protection relay symbols 480
- voltmetric commutator switch symbols 545
- VPJ files 1650

## W

- WBlocked circuits 729, 736
- wd\_fam.dat files 182
- wd\_lang1.mdb files 1204
- WD\_M blocks
  - about 253
  - codes for replaceable parameters 239
  - copying attributes to 255
  - default blocks 254
  - defaults in 253
  - inserting 256
  - missing attributes 255
  - new drawings 168
  - overrides 815
  - replacing 254–255
  - saving project settings 240–241

- updating 255
- WD\_PNLM blocks
  - configuration information 1527
  - copying attributes to 255
  - inserting 256
- WD\_SLB code 1232
- WD\_TB attribute 1213, 1708
- WD\_TB attributes 1218
- WD\_ZIP utility 187
- wd.env files 129, 182, 187, 279
- WDA files 1509
- WDBLKNAM attribute 1271, 1277
- WDD files 182, 761
- wddinrl.xls file 853
- WDF files 182
- WDI files 182, 635
- WDL files 182, 1225, 1708
- WDN files 182, 1686
- WDP files
  - about 138
  - contents 187
  - settings in 202
- WDR files 182, 807–808
- WDT files 182, 1220, 1708
- WDTYPE attribute 329
- WDW files 182, 922, 1633
- WDX files 182
- WDXX blocks 887
- web pages
  - linking catalogs to 1277
  - options 1207
  - saving projects as 1205–1207
- WEBLINK assignments 1277
- whistle symbols 570
- width
  - ladders 963
  - symbols 339
  - terminal strips 1130
- wildcard characters
  - reports 1318
  - title blocks 1213, 1221
- winding symbols 565
- Wire Annotation Exception dialog
  - box 1437
- Wire Annotation Exception reports
  - about 1428
  - formatting 1454
  - generating 1437
- wire arrow symbols 298, 320, 431, 580
- wire colors
  - encoding 988, 990
  - wire color files 182
- Wire Conduit Routing Data Fields to Report dialog box 1396
- Wire Connection reports
  - about 1428
  - formatting 1461
  - generating 1441
- wire connection styles 2112
- wire connections
  - add 1939
  - annotations 1587–1588
  - converting lines to 1660
  - customizing 2112
  - inserting 351, 353
  - limits on 895
  - styles 2112
  - tools 349
- wire crossings 1142, 1157, 1159, 1167
- wire dot symbols 298
- Wire From/To Data Fields to Report dialog
  - box 1384
- Wire From/To reports
  - about 1402
  - fields in 1384
  - formatting 1484
  - generating 1419
- wire gaps
  - about 958
  - repairing 1689
- wire grids 720
- Wire It tab (Connector Selection dialog
  - box) 1174
- wire jumpers 856–857
- Wire Jumpers dialog box 857
- Wire Label Data Fields to Report dialog
  - box 1394
- Wire Label reports
  - about 1402
  - display settings 1330
  - fields in 1394
  - formatting 1495



- generating 1425
- wire label symbols
  - in-line wire label symbols 509
  - reports 1394, 1402, 1425, 1495
  - schematic attributes 320
- wire layers 275, 1195
  - color and gauge information 988, 990
  - valid layers 271, 902
- wire lists
  - exporting for Cable & Harness 1519
  - importing 1167
  - reports 1370, 1410, 1471
- wire loss 720
- wire markers 925
- wire networks
  - about 895
  - connection reports 1029
- wire number layers 261
- wire numbers
  - 3-phase 975–976
  - about 970
  - adding to footprints 1587
  - automatically inserting 971
  - codes for replaceable
    - parameters 239
  - colors 988, 990
  - configuring for export 1521
  - convert text 1940
  - converting text to 1646
  - copying 1000
  - displaying 970, 1010
  - displaying wires 978
  - drawing properties 979, 1003
  - duplicate 1686, 1688, 1692, 1694
  - editing 991–992, 994
  - erasing 1010
  - extra copies of 1000
  - finding 986–987
  - fixed 991–992, 994
  - flipping 1003
  - formats 2070
  - gauge and 988, 990
  - hiding 1010
  - in-line 1002
  - incrementing 1007
  - inserting 979
  - layers 261, 970
  - leaders 922, 998
  - mirroring 1003
  - motor circuits 975
  - motor symbol tags in 2059
  - moving 996–997, 999
  - naming conventions 298
  - no wire numbering 28
  - order settings 220, 233
  - parameters 990
  - PLC tags 977
  - position 979
  - predefined 2075
  - project-wide 992
  - project-wide properties 1195
  - replacing text 986–987
  - repositioning leader text 998
  - resizing 1008
  - rotating 997, 1008
  - schematic attributes 320
  - schematic wire information 1590, 1592
  - settings 228
  - surfing 1187
  - swapping 999
  - tags 970
  - toggling position 1003
  - tracking changes to 1200
  - troubleshooting 978
  - types of 970
  - unfixed 994
  - WD\_M block attributes 253
  - wire tags 972–973
- Wire Numbers tab (Drawing properties dialog box) 228
- Wire Numbers tab (Properties dialog box) 215
- wire shields 956
- Wire Signal or Stand-Alone Reference Report dialog box 1019
- wire signal symbols
  - arrows 1011–1012, 1015
  - attributes 320
  - naming conventions 298
  - project-wide changes 1195, 1199

- Wire Size Lookup dialog box 720–721
- Wire Tagging (project-wide) dialog box 973
- Wire Tagging dialog box 972
- wire tags
  - formats 970
  - inserting 972–973
- wire tees 919–920, 1033
- wire types
  - changing 275, 277
  - defining 2056
  - grid 271, 902
  - importing 271–272, 902–904, 907
  - setting default 278
- wire ways
  - generating spreadsheet records 853
  - inserting labels 1631
- Wire/Conduit Routing Report dialog box 1636
- wires
  - 3-phase wires 917–918
  - about 895
  - angled 913
  - annotations 1348, 1428, 1437, 1454, 1531, 1587–1588, 1590, 1592
  - arrow symbols 431, 1011
  - bending 922
  - cable markers 930
  - colors 922–924, 988, 990
  - conduit information 1631
  - conduit routing data in reports 1396
  - connection report data fields 1354
  - connection templates 351
  - connection tools 349
  - constraints 1065
  - converting lines to 1651, 1653, 1656–1657, 1659
  - creating 271, 902
  - de-rating factors 720
  - displaying 978
  - displaying connections 1132
  - editing 271, 902
  - exporting connection data 1504
  - extracting 949, 953
  - fanning markers 1020–1026
  - from/to reports 1029, 1384
  - gaps 958, 1689
  - gauge 922, 988, 990
  - importing occurrences from Inventor 1166–1167
  - in-line components 630
  - in-line markers 925
  - in-line wire label symbols 509
  - in-line wire numbers 1002
  - inserting 913, 917–919, 1140
  - interconnecting components 919
  - labels 922–924
  - ladders 961, 963
  - layers 265–266, 275, 923–924, 988, 990, 1195
  - loads 720
  - multi-connection sequencing 1134–1135, 1138
  - multiple buses 1163
  - multiple wire buses 917–918
  - numbering 215
  - paralleled 720
  - pigtails 339
  - point-to-point tools 1140
  - replacing 1689
  - reports 1402, 1410, 1419, 1428, 1441, 1461, 1471, 1484
  - resizing 720–721
  - routing reports 1636
  - schematic attributes 320
  - scooting 798, 800
  - sequencing 1029–1031, 1037
  - signal reports 1019
  - spacing 2053
  - spare wires 1632
  - splices 1185
  - stand-alone reference reports 1019
  - stretching 921, 2082
  - switching types 275, 912
  - tags 972–973
  - tee markers 1033–1034
  - terminals 1132
  - tracing 1689
  - trimming 919–920, 2050
  - troubleshooting 978
  - unique IDs 1521

- wire crossings 1142, 1157, 1159, 1167
  - wire grids 720
  - wire labels 1394, 1425, 1495
  - wire lists 1167, 1370, 1519
  - wire loss 720
  - wire numbers 970
  - wire types 271, 275, 277–278, 902, 2056
  - zooming extents and 919
  - WO\_CBLWIRES table 954
  - workflows
    - Circuit Builder 655, 2006
    - one-line symbols 2098
    - parent symbols 2090
    - pin lists 1984
    - PLC modules 2005
    - source and destination markers 1996
    - terminal jumpers 1123
    - terminal symbols 2094
  - workgroups
    - collaborative design 158
    - Vault setup 2134
  - workspaces 26, 2134
  - WW1 files 1633
- X**
- X Zone grid 234
  - X Zone Setup dialog box 234
  - X-Y grid 236
  - X-Y Grid Setup dialog box 236
  - Xdata
    - about 1526
    - converting to attributes 1527
    - editing 1695
    - power checks and 1668
    - Symbol Builder attribute templates 2107
  - Xdata Editor dialog box 1695
  - XHW files 645, 651
  - XLS files
    - din rails 853
    - exporting component data 1502
    - exporting panel layout data 1506
    - exporting PLC data 1503–1505
    - exporting spreadsheet data 1500–1501, 1503
    - exporting terminal data 1506–1507
    - importing connector data 1175
    - importing spreadsheet data 1500
    - mapping to blocks 1663–1665
    - PLC database content 630
    - reports 1318
    - RSLogix data 640–642
    - structure 1175
    - updating drawings with data 1508
  - XML files
    - importing connector data 1175
    - importing data from Inventor 1166–1167
    - Unity Pro data 645, 651–652
  - XSY files 645, 651–652
- Z**
- zener diode symbols 426, 575
  - zip utility 187–188
  - zooming in or out 919

