

Autodesk®
Lustre® 2009 Extension 1

A Discreet® Systems product

Release Notes
Service Pack 1



© 2009 Autodesk, Inc. All rights reserved. Except as otherwise permitted by Autodesk, Inc., this publication, or parts thereof, may not be reproduced in any form, by any method, for any purpose.

Certain materials included in this publication are reprinted with the permission of the copyright holder.

The following are registered trademarks or trademarks of Autodesk, Inc., in the USA and other countries: 3DEC (design/logo), 3December, 3December.com, 3ds Max, ADI, Algor, Alias, Alias (swirl design/logo), AliasStudio, Alias|Wavefront (design/logo), ATC, AUGI, AutoCAD, AutoCAD Learning Assistance, AutoCAD LT, AutoCAD Simulator, AutoCAD SQL Extension, AutoCAD SQL Interface, Autodesk, Autodesk Envision, Autodesk Intent, Autodesk Inventor, Autodesk Map, Autodesk MapGuide, Autodesk Streamline, AutoLISP, AutoSnap, AutoSketch, AutoTrack, Backdraft, Built with ObjectARX (logo), Burn, Buzzsaw, CAiCE, Can You Imagine, Character Studio, Cinestream, Civil 3D, Cleaner, Cleaner Central, ClearScale, Colour Warper, Combustion, Communication Specification, Constructware, Content Explorer, Create>what's>Next> (design/logo), Dancing Baby (image), DesignCenter, Design Doctor, Designer's Toolkit, DesignKids, DesignProf, DesignServer, DesignStudio, Design|Studio (design/logo), Design Web Format, Discreet, DWE, DWG, DWG (logo), DWG Extreme, DWG TrueConvert, DWG TrueView, DXF, Ecotect, Exposure, Extending the Design Team, Face Robot, FBX, Fempro, Filmbox, Fire, Flame, Flint, FMDesktop, Freewheel, Frost, GDX Driver, Gmax, Green Building Studio, Heads-up Design, Heidi, HumanIK, IDEA Server, i-drop, ImageModeler, iMOUT, Incinerator, Inferno, Inventor, Inventor LT, Kaydara, Kaydara (design/logo), Kynapse, Kynogon, LandXplorer, Lustre, Matchmover, Maya, Mechanical Desktop, Moldflow, Moonbox, MotionBuilder, Movimento, MPA, MPA (design/logo), Moldflow Plastics Advisers, MPI, Moldflow Plastics Insight, MPX, MPX (design/logo), Moldflow Plastics Xpert, Mudbox, NavisWorks, ObjectARX, ObjectDBX, Open Reality, Opticore, Opticore Opus, Pipeplus, PolarSnap, PortfolioWall, Powered with Autodesk Technology, Productstream, ProjectPoint, ProMaterials, RasterDWG, Reactor, RealDWG, Real-time Roto, REALVIZ, Recognize, Render Queue, Retimer, Reveal, Revit, Showcase, ShowMotion, SketchBook, Smoke, Softimage, Softimage|XSI (design/logo), SteeringWheels, Stitcher, Stone, StudioTools, Topobase, Toxik, TrustedDWG, ViewCube, Visual, Visual Construction, Visual Drainage, Visual Landscape, Visual Survey, Visual Toolbox, Visual LISP, Voice Reality, Volo, Vtour, Wire, Wiretap, WiretapCentral, XSI, and XSI (design/logo).

The following are registered trademarks or trademarks of Autodesk Canada Co. in the USA and/or Canada and other countries: Backburner, Multi-Master Editing, River, and Sparks.

All other brand names, product names or trademarks belong to their respective holders.

Disclaimer

THIS PUBLICATION AND THE INFORMATION CONTAINED HEREIN IS MADE AVAILABLE BY AUTODESK, INC. "AS IS." AUTODESK, INC. DISCLAIMS ALL WARRANTIES, EITHER EXPRESS OR IMPLIED, INCLUDING BUT NOT LIMITED TO ANY IMPLIED WARRANTIES OF MERCHANTABILITY OR FITNESS FOR A PARTICULAR PURPOSE REGARDING THESE MATERIALS.

Published by: Autodesk, Inc.

111 McInnis Parkway

San Rafael, CA 94903, USA

Title: Autodesk Lustre 2009 Extension 1 Service Pack 1 Release Notes

Document Version: 2

Date: June 16, 2009

contents

Contents

1	Release Information	1
	Summary	1
	About These Release Notes	1
	Related Documentation	1
	Accessing Online Help	2
	Accessing PDF Documentation	3
	Fixed and Known Bugs	4
	Contacting Customer Support	4
2	System Information	5
	Summary	5
	Overview of New and Updated Sections	5
	Software Versions and Associated Platforms for Lustre 2009 Extension 1 SP1	7
	Release Requirements for Lustre 2009 Extension 1 SP1	7
	Hardware System Requirements	7
	Discreet Kernel Utilities (DKU) 4.0.4 Required	8
	New Installation and Configuration Guide Available	9
	Items No Longer Supported as of Lustre 2009	9
	Configuring the Memory Allocation	9
	Using the /3GB Startup Switch to Increase Virtual Address Space	10
	Adding 1GB RAM to the IBM 6223	11
	Wiretap Gateway	13
	Preparing Your Installation	13
	Stand-alone Installation	14
	Distributed Deployment	15
	Licensing the Wiretap Gateway	19

Verifying Installed Components	20
Wiretap Gateway Configuration File	21
Upgrading the NVIDIA Graphics Card Driver	22
dlConfigCheck Utility	22
Disabling the InfiniBand Sockets Direct Protocol (SDP) Flags.....	22
Reverting Incinerator From Lustre 2009 Extension 1 to a Previous Version	23
Obtaining the Host ID of the Linux Workstation	23
Storage Configuration	24
Standard VTR and VTR Emulation Control Cable.....	25
Audio Input and Output	27
Autodesk Control Surface Panel	28
Modifying the User Rules File	28
Modifying the Default Rules File	28
Configuration Files.....	28
init.config File	29
Upgrade Compatibility	29
Wiretap Interoperability	30
SDP over Infiniband Support	30

3 User Guide Addendum 31

Summary	31
Overview.....	31
Softness Scale for Colour Isolation.....	31
Features No Longer Used in Lustre	32
Limitations for Lustre 2009	32
Lustre on a Linux Workstation.....	32
Telecine-mode Payout	32
Wiretap	33
Wiretap Command Line Tools	33
Timewarp from Smoke or Flame	34
Publish	34

4 Installation Documentation Workflows 37

Summary	37
Overview.....	37
Reinstalling from Scratch.....	37
Connecting New or Expanded Stone Direct Storage	38
Upgrading Lustre	39
Documentation FAQs	39

Contents

How Do I Request a License for Lustre?	39
How Do I Learn About the Latest Updates?	40
How Do I Find Out About All the New Features for This Release?	40



Release Information

Summary

About These Release Notes	1
Related Documentation	1
Fixed and Known Bugs	4
Contacting Customer Support	4

About These Release Notes

The chapters in this document provide a concise collection of important release information about Autodesk® Lustre® 2009 Extension 1 Service Pack 1.

[Chapter 1, "Release Information,"](#) on page 1 - Provides information about related documentation and contacting customer support.

[Chapter 2, "System Information,"](#) on page 5 - Provides infrastructure and hardware-related information.

[Chapter 3, "User Guide Addendum,"](#) on page 31 - Provides new information that was released after the user guide went to print.

[Chapter 4, "Installation Documentation Workflows,"](#) on page 37 - Provides common installation workflows, such as reinstalling from scratch or upgrading your application.

Check the Web site for the most up-to-date version of these *Release Notes*.

Related Documentation

The following table describes the documentation associated with your application.

User Guides	Provides
<i>Autodesk Lustre 2009 Extension 1 User Guide</i>	Detailed instructions on using the software.
<i>Autodesk Control Surface User Guide</i>	Detailed instructions on using the Autodesk control surface and the Tangent CP100.
<i>Autodesk Lustre 2009 Extension 1 New Features Guide</i>	Information about the new features for this release.
<i>Autodesk Lustre 2009 Hot Keys Card</i>	A list of the most frequently used hot keys.
<i>Autodesk Lustre 2009 Extension 1 Service Pack 1 Release Notes</i>	A complete list of documentation and information on late-breaking features.
<i>Autodesk Lustre 2009 Extension 1 Service Pack 1 Fixed and Known Bug List</i>	A complete list of fixed and known bugs for this release.
Installation and Configuration Guides	Provides
<i>Hardware Setup Guide</i> (for your workstation)	Information on how to setup your workstation and video I/O peripherals.
<i>Autodesk Lustre 2009 Extension 1 Installation and Configuration Guide for Linux Workstations</i>	Information about setting up your hardware, Linux operating system, storage, and installing and licensing your Autodesk Lustre software.
<i>Autodesk Lustre 2009 Extension 1 Software Installation Guide for Windows Workstations</i>	Information about installing and licensing your Autodesk Lustre software on Windows workstations.
<i>Autodesk Incinerator 2009 Extension 1 Installation and User Guide</i>	Information on installing, licensing, and using Autodesk® Incinerator®.
Other Guides	Provides
<i>Autodesk Lustre Sparks API Reference Guide</i>	Instructions for developing Sparks® plugins for Lustre.
<i>Autodesk Backburner 2008.1 Installation Guide</i> <i>Autodesk Backburner 2008.1 User Guide</i>	Information on how to install, set up, and use Autodesk® Backburner™.

Consult the Autodesk Web site at www.autodesk.com/lustre-documentation for the latest version of guides, release notes, and fixed and known bugs documents.

Accessing Online Help

Autodesk provides complete documentation in an accessible HTML help system that is displayed in a Web browser. The Help is automatically installed unless specified otherwise during the software installation. Refer to the *Autodesk Lustre Software Installation Guide* for this release.

You can install the Help on another system without installing Lustre. For Windows®, select only Online Help when prompted to select components in the Lustre Installer. For Linux®, you can copy the *Documentation/help* directory from the CD onto another workstation.

To start the help system from Lustre:

- Click the Help button, located in the lower-right corner of all menus, or press **SHIFT+F1**.



To start the help system from the desktop:

1. If using the Windows version of Lustre, choose Start | Programs | Autodesk | Lustre<version number> | Online Help from the Windows task bar.
The Help appears in a browser window.
2. If using the Linux version of Lustre, open a shell and type:

```
<browser> /usr/autodesk/lustre<version number>/help/index.html
```

 (where <browser> is either 'mozilla' or 'firefox', as required.)

To copy the Help to another system:

1. Copy the *Documentation/help* directory from the software CD-ROM to the new location on another system.
2. To start the Help after you copy the help directory, open the *help/index.html* file.

Accessing PDF Documentation

The complete documentation set is available in PDF (Portable Document Format) for online viewing and printing. On Windows and Linux systems, use Adobe® Acrobat® Reader™ to view and print the PDF files. You can access the PDF files from the Lustre software CD or from www.autodesk.com/lustre-documentation.

NOTE: If you do not have Acrobat Reader, you can download a free copy from the Adobe Web site (www.adobe.com).

From the Lustre Application CD

You can view and print the PDF files from the Lustre CD using Adobe Acrobat Reader. All PDF files are located in a directory called *Documentation* at the top level of the CD.

To view the PDF files on the application CD:

1. Place the Lustre CD in the CD-ROM drive of your system.
2. If using the Windows version of Lustre, in Windows Explorer, go to the *Documentation* folder on the CD.
3. If using the Linux version of Lustre, open a Linux shell and navigate to the online help directory. Type:

```
cd /usr/autodesk/lustre<version number>/documentation
```

4. To view a PDF file, do one of the following:

- If using the Windows version of Lustre, double-click the desired file.
- If using the Linux version of Lustre, type:

```
acroread <filename>
```

The file opens in Acrobat Reader.

Fixed and Known Bugs

For a list of fixed and known bugs for this release, see the PDF file *lustre2009ext1_fixed_known_bugs.pdf*. This PDF file is available on the Web at www.autodesk.com/lustre-documentation-extension.

Contacting Customer Support

A list of contact information for Autodesk Media and Entertainment Customer Support is available at www.autodesk.com/support.

Customer support is also available through your Autodesk reseller. To find a reseller near you, consult the reseller look-up database on the Autodesk web site at www.autodesk.com/resellers.

System Information



Summary

Overview of New and Updated Sections	5
Software Versions and Associated Platforms for Lustre 2009 Extension 1 SP1	7
Software Versions and Associated Platforms for Lustre 2009 Extension 1 SP1	7
Release Requirements for Lustre 2009 Extension 1 SP1	7
New Installation and Configuration Guide Available	9
Items No Longer Supported as of Lustre 2009	9
Configuring the Memory Allocation	9
Wiretap Gateway	13
Upgrading the NVIDIA Graphics Card Driver	22
dlConfigCheck Utility	22
Disabling the InfiniBand Sockets Direct Protocol (SDP) Flags	22
Reverting Incinerator From Lustre 2009 Extension 1 to a Previous Version ...	23
Obtaining the Host ID of the Linux Workstation	23
Storage Configuration	24
Standard VTR and VTR Emulation Control Cable	25
Audio Input and Output	27
Autodesk Control Surface Panel	28
Configuration Files	28
Upgrade Compatibility	29
Wiretap Interoperability	30
SDP over Infiniband Support	30

Overview of New and Updated Sections

This chapter highlights important notes and procedures related to installation and hardware configuration.

New changes for Lustre 2009 Extension 1 Service Pack 1:

For all platforms:

- A number of bugs impacting both Windows and Linux systems were fixed in this service pack. It is recommended to upgrade your systems to this service pack (and to the new DKU for Linux users) to benefit from these fixes.

See the latest *Autodesk Lustre 2009 Extension 1 Fixed and Known Bugs List* for a complete list of bugs fixed in SP1. This document is available from your Lustre installation package, as well as online at www.autodesk.com/me-documentation.

For Linux platforms:

- A New HP® hardware platform (HP Z800) is available for Linux users, featuring the NVIDIA® Quadro® FX5800 graphics card, and the ATTO Celerity FC-84EN 8Gigabit fibre channel host adapter. This workstation works only with the new Red Hat® Enterprise Linux® 5.3 operating system. See [“Lustre Master, Lustre HD, and Lustre Station - Linux Stand-alone”](#) on page 7.
- Red Hat Enterprise Linux 5.3 is now available for the HP Z800 workstation. This is the only operating system supported on the HP Z800 platform, and is not supported on other workstations. See [“Software Versions and Associated Platforms for Lustre 2009 Extension 1 SP1”](#) on page 7.
- Discreet® Kernel Utilities (DKU) version 4.0.4 is required to fix a number of bugs and provide support for the new workstation and Linux distribution. See [“Discreet Kernel Utilities \(DKU\) 4.0.4 Required”](#) on page 8
- New *Autodesk Lustre Installation and Configuration Guide for Linux Workstations* (Linux only). See [“New Installation and Configuration Guide Available”](#) on page 9.

New changes for Lustre 2009 Extension 1

- The Wiretap Gateway application is a transcoding engine that is installed on a Linux workstation and is used to browse files and decode/transcode media. For installation and information on the Wiretap Gateway, see [“Wiretap Gateway”](#) on page 13.
- The NVIDIA graphics card driver is updated to version 165.50 for Windows users. To upgrade the driver for Windows, see [“Upgrading the NVIDIA Graphics Card Driver”](#) on page 22.
- The latest Discreet Kernel Utility (DKU) updates the NVIDIA graphics card driver (version 165.33.18) and the AJA driver (version 4.3). This upgrade is applicable to Linux users only.

NOTE: The new AJA driver upgrade is not applicable for Windows users.

- Turning off the InfiniBand™ sockets direct protocol (SDP) on the IBM Z Pro 6223 Lustre Media Server in order to transcode RED media. See [“Disabling the InfiniBand Sockets Direct Protocol \(SDP\) Flags”](#) on page 22.
- In order to run Autodesk Smoke/Flame on the same workstation as Lustre 2009 Extension 1, you need to install either Smoke/Flame 2010, or Smoke/Flame 2009 Extension 1 SP4.

- In order to run Lustre 2009 on the same workstation as Lustre 2009 Extension 1, you need to install Lustre 2009 Service Pack 4 or later.
- Grades created in Lustre 2009 Extension 1 are not backward compatible with previous versions of Lustre.

Software Versions and Associated Platforms for Lustre 2009 Extension 1 SP1

This release of Lustre 2009 Extension 1 SP1 is available for the Windows® XP SP2 platform, Red Hat Enterprise Linux 5.3 with Workstation Option (only on the HP Z800 stand-alone workstation), and for Red Hat Enterprise Linux Workstation 4 Update 3 (for older Incinerator and stand-alone workstations).

Release Requirements for Lustre 2009 Extension 1 SP1

NOTE: Autodesk recommends archiving your media and project data before upgrading the software.

Hardware System Requirements

The following platform configurations are supported for Lustre 2009 Extension 1 SP1.

Lustre Master, Lustre HD, and Lustre Station - Windows

Computer	Graphics Card	Graphics Driver	VIO
IBM® Z Pro 6223	NVIDIA® Quadro® FX5500 + SDI	165.50	DVS
HP® xw8400	NVIDIA Quadro FX5500 + SDI	165.50	DVS
HP® xw8600	NVIDIA Quadro FX5600 + SDI	165.50	AJA

Lustre Master, Lustre HD, and Lustre Station - Linux Stand-alone

Computer	Graphics Card	Graphics Driver	VIO
HP® Z800	NVIDIA® Quadro® FX 5800	180.61	AJA
HP® xw8400	NVIDIA® Quadro® FX5500 + SDI	165.33.18	DVS
HP® xw8600	NVIDIA Quadro FX5600 + SDI	165.33.18	AJA

Lustre Master Station and Lustre Station - Linux (with Incinerator)

Computer	Graphics Card	Lustre Media Server	Incinerator Nodes	VIO	Storage
IBM Z Pro 6223	NVIDIA Quadro FX5500 + SDI	eServer X346	eServer X336	DVS	Autodesk Stone Direct IR-series
HP xw8400	NVIDIA Quadro FX5500 + SDI	HP xw9400	Proliant HP DL140 G3	DVS	Autodesk Stone Direct XR-series
HP xw8600	NVIDIA Quadro FX5600 + SDI	HP xw8600	Proliant HP DL160 G5	AJA	Autodesk Stone Direct XR-series

- Graphics driver 165.33.18 for Incinerator.
- Discreet Kernel Utilities 4.0.4 (for Linux operating systems).

NOTE: The cabling for the DVS has changed since Lustre 2008. Refer to [“Standard VTR and VTR Emulation Control Cable”](#) on page 25.

Discreet Kernel Utilities (DKU) 4.0.4 Required

You must install the Discreet Kernel Utilities (DKU) 4.0.4 before installing or upgrading to Lustre 2009 Extension 1 SP1 (Linux). The new DKU installs the latest Discreet customized kernel, a new graphic driver and a new InfiniBand driver.

DKU 4.0.4 must be installed on all Incinerator components including the Workstation, the Media Server, and the Incinerator nodes.

To install the DKU from a tar file:

1. Download the DKU *tar* file from Autodesk. Make sure you get the correct DKU version (4.0.4) for your release of the Lustre application. The download link is provided in the release announcement you received from Autodesk.
2. Go to the directory where the *tar* file was downloaded, and unpack it by typing: **tar -zxf DKU_<version_number>.tar.gz** where <version_number> is the version of the DKU, for example: **tar -zxf DKU_4.0.4.tar.gz**
The DKU *tar* file is unpacked into a new directory.
3. Go to the newly created DKU installation directory and launch the DKU installation script:
./INSTALL_DKU
4. Wait for the DKU installation script to complete.

NOTE: When the script completes for the Lustre workstation, a warning appears to update the AJA board, and you are returned to the command prompt.

5. Before rebooting the system, if any storage device (external disk arrays or internal storage) were previously disconnected as part of an operating system installation, reconnect them and power them up.

NOTE: Wait for all the disks in the storage devices to power up before restarting the system. The green light for each disk stops flashing once it is fully powered up.

6. Reboot the system. Type: **reboot**
7. After you install the DKU, as root, run the *dlConfigCheck* script to ensure all firmware and drivers are current. See [“dlConfigCheck Utility”](#) on page 22.

New Installation and Configuration Guide Available

This service pack introduces the new *Autodesk Lustre Installation and Configuration Guide for Linux Workstations*. This guide provides complete information on setting up your Lustre workstation, including hardware set-up, Linux installation, media storage configuration, application installation and licensing, as well as BrowseD and background rendering installation procedures.

This document is available in your Lustre installation package, and online at www.autodesk.com/lustre-documentation.

Items No Longer Supported as of Lustre 2009

In this release, the following item is no longer supported in Lustre configurations:

- NVIDIA® FX4000 SDI PCI-E graphics card.

Configuring the Memory Allocation

NOTE: This upgrade is only applicable to Windows users.

To make sure your system is operating at its potential, you need to complete the following:

- Increase the user-mode processes (e.g., applications) virtual address space by using a /3GB startup switch.

NOTE: This is necessary for both the IBM IntelliStation Z Pro 6223 and HP xw8400 workstation.

- Increase the RAM to 4GB.

NOTE: This is only necessary for the IBM IntelliStation ZPro 6223.

Using the /3GB Startup Switch to Increase Virtual Address Space

Windows uses 4GB of virtual address space. 2GB is allocated to user-mode processes (e.g., applications), while the other 2GB is allocated to kernel-mode processes (e.g., the operating system). The /3GB startup switch allows the memory for the applications to increase to 3GB while reducing the memory for the operating system to 1GB. This increases the speed of your application.

NOTE: In order to complete this upgrade, your system must be running Windows XP Professional Service Pack 2.

To set up the /3GB switch:

1. Click Start>Settings>Control Panel.
2. In the Control Panel window, double-click on Systems.
3. In the Advanced tab, click the Settings button in the Startup and Recovery group.

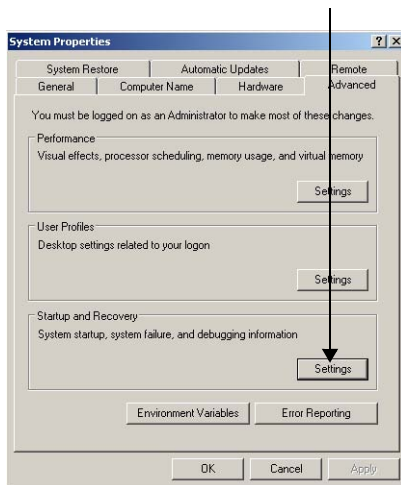

4. Click Edit.

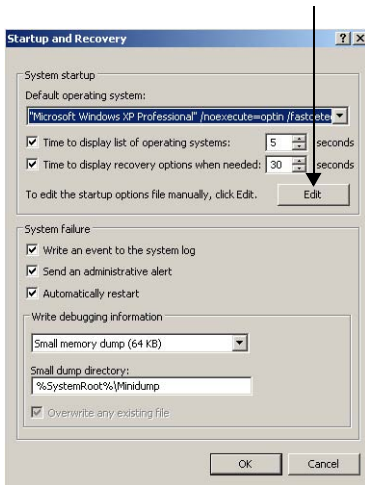

The *boot.ini* file opens in Notepad.

5. Copy the operating systems line and paste it on the next line. E.g.,

```
multi(0)disk(0)rdisk(0)partition(1)/WINDOWS="Microsoft Windows XP Professional" /noexecute=optin /fastdetect
```
6. Make the following changes to the first line of text:
 - Modify the name of the operating system to “Microsoft Windows XP Professional 3GB”.
 - Add “/3GB”.
 - Add “/userva=2432”.

E.g.,

```
multi(0)disk(0)rdisk(0)partition(1)/WINDOWS="Microsoft Windows XP Professional 3GB" /noexecute=optin /fastdetect /3GB /userva=2432
```
7. Save the file and restart your computer.

The /3GB switch should now be the default configuration.

Adding 1GB RAM to the IBM 6223

The minimum requirement for running Lustre 2009 Extension 1 on the IBM IntelliStation Z Pro 6223 is 4 GB of RAM. Currently, users have 1GB in DIMM 1 and DIMM 2 and 512MB in DIMM 3 and DIMM 4. The memory needs to be installed in pairs.

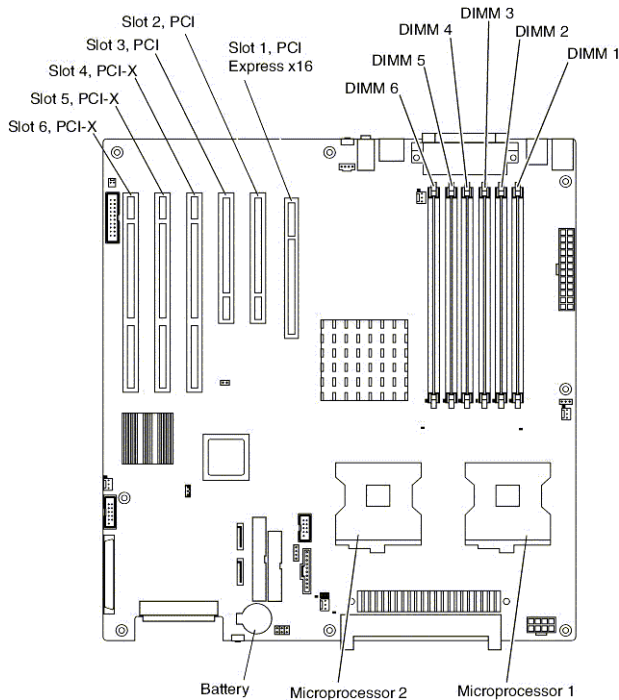

To make sure your system has 4GB, complete one of the following:

- Purchase and install two 512MB DDR2 SDRAM DIMM.
- Purchase and install two 1GB DDR2 SDRAM DIMM.

NOTE: Make sure you do not exceed 4GB of RAM.

To install two 512MB of RAM:

1. Insert the two 512MB DDR2 SDRAM DIMM into DIMM 5 and DIMM 6.
You now have 4GB of RAM.
2. Restart your system for the change to take effect.

To install two 1GB of RAM:

1. Remove the two 512MB DDR2 SDRAM DIMM from DIMM 3 and DIMM 4.
2. Insert the two 1GB DDR2 SDRAM DIMM into DIMM 3 and DIMM 4.
You now have 4GB of RAM.
3. Restart your system for the change to take effect.

Wiretap Gateway

The Wiretap Gateway is a transcoding engine that is installed on a Linux workstation and is used to browse files and decode/transcode media. You would use this new server to expose the contents of a file system (e.g., RED (.r3d), QuickTime (.mov), and MXF (.mxf)). Since decompressing compressed media is a CPU intensive task, performance may vary based on your system configuration.

There are two main deployment models for Wiretap Gateway.

Stand-alone installation — This is the easiest installation model, as all components are automatically installed and configured on a single workstation when you install Lustre. This deployment model is suitable for media browsing with occasional media encoding and decoding as it offers the lowest level of performance. A stand-alone installation can only exist on a Linux workstation.

Distributed Deployment — This advanced deployment model offers increased performance, as processing is distributed across several dedicated Backburner Server nodes on your network. This is a scalable deployment model: performance can be maximized by moving as many components as possible onto dedicated machines on your network. This is the preferred deployment for Lustre Windows and Linux workstations where the Wiretap Gateway resides on a separate server, or for an Incinerator.

The following sections provide information and installation instructions for each deployment option. Choose the configuration that best suits your needs.

Preparing Your Installation

Before you begin installing WiretapCentral, perform the following steps to prepare for the installation. Some of these tasks must be performed from a computer connected to the Internet.

- Decide which deployment model you want to use. Refer to the descriptions in the previous section.
- Obtain your installation media. All necessary components for a stand-alone or distributed deployment setup are available from the installation directory of the Autodesk Lustre application. You can get the application installation package on DVD or you can download it as a tar file. The download link is provided in the Release Announcement you received from Autodesk.
- Download the latest version of the Autodesk Backburner Installation Guide, Autodesk Backburner User Guide, and Autodesk Lustre Installation Guide from www.autodesk.com/me-documentation.
- If you are performing a distributed deployment, make sure the systems you plan to install the various components on meet the following recommended specifications:

Component	Hardware	Operating System	Other Requirements
WiretapCentral	- 64-bit dual core CPU, such as AMD™Opteron™ or Intel® Xeon® - 1 GB of RAM or better GigE or InfiniBand networking - 500 GB Hard drive or larger	32-bit or 64-bit Red Hat® Enterprise Linux® Workstation 4 Update 2 or Update 3. It is recommended to disable SELinux on the WiretapCentral machine.	Direct access to the Wiretap network. WiretapCentral must reside on the same subnet as the Lustre workstation. Apache Web Server version 2.0.52 or later.
Wiretap Gateway	- 64-bit dual core CPU - 1 GB of RAM or better - GigE or InfiniBand	Any 64-bit Linux distribution.	Direct connection to the SAN/NAS/DAS media storage in your facility.
Backburner Server and Media I/O Adapter	- 64-bit dual core CPU - 1 GB of RAM or better - GigE or InfiniBand	Any 64-bit Linux distribution.	

NOTE: If you have Autodesk® Burn® render nodes in your facility, you can use them as Backburner Servers and Media I/O Adapters. These components are automatically installed with the latest version of the Burn software. See the *Autodesk Burn Installation and User Guide* for details about Autodesk Burn.

Stand-alone Installation

In a stand-alone installation, Wiretap Gateway and all background processing components (Backburner Server, Backburner Manager, and the Media I/O Adapter) are installed on the same workstation as the Lustre application.

A stand-alone installation is the easiest deployment model, as all necessary components are automatically set up by the Lustre application installer. However, all media processing is performed locally, which can have a significant impact on system performance if you are using several components at the same time.

NOTE: This setup is only applicable for a Linux (not Incinerator) workstation.

To set up a stand-alone configuration on a Lustre workstation:

1. As root, open a terminal and browse to the Lustre application installation directory.
2. Run the application installation script by typing:

```
./INSTALL_<APPLICATION_NAME>
```

3. Perform the remaining steps of a regular application installation, as guided by the application installer. Refer to the *Lustre 2009 Software Installation Guide for Linux Workstations* for more details.

Lustre, Wiretap Gateway, and all the background processing components are automatically installed and configured on the workstation.

4. License the Wiretap Gateway. See [“Licensing the Wiretap Gateway”](#) on page 19.
5. Verify that all the components have been properly installed. See [“Verifying Installed Components”](#) on page 20.

As mentioned earlier, in a stand-alone deployment all media processing takes place locally, and system resources are shared between such background tasks and the Lustre application running in the foreground.

To avoid competition for workstation resources and to increase productivity, it is recommended that you relocate some or all the components to dedicated machines on your network. The following section describes the levels of scalability a distributed deployment offers.

Distributed Deployment

Although more complex to set up, a distributed deployment offers the highest level of flexibility and performance for media decoding, as it allows the CPU-intensive background processing to be off-loaded from the Lustre workstation and distributed across a Backburner processing network for increased productivity.

Depending on your performance needs, you can scale your configuration as much as necessary. Here are some examples of typical deployment scenarios.

Example #1: Lustre Workstation with Wiretap Gateway

NOTE: This example is only applicable to Lustre on a Linux workstation. It is not applicable to a Windows or an Incinerator setup.

In this scenario, Wiretap Gateway is running on the Lustre Linux workstation, while processing is performed by several dedicated nodes in a render farm. Each processing node comprises a Backburner Server and a Media I/O Adapter.

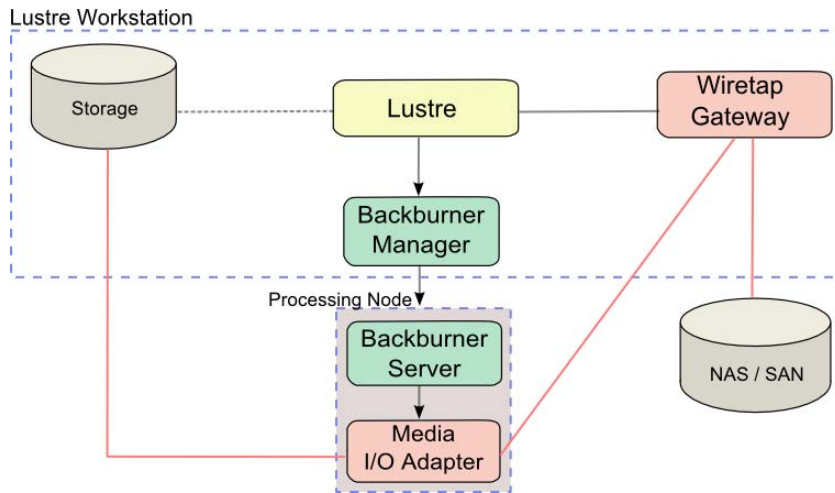

NOTE: Since processing components (Backburner Server and Media I/O Adapter) are automatically installed on the Lustre workstation, the workstations themselves can be used as processing nodes during off-peak hours.

To install Lustre and the Wiretap Gateway on the same workstation:

1. Download the Lustre Linux installation package from the following location: *ftp://ftp.discreet.com/pub1/release/lustre/lustre2009/Lustre_2009.1.tar.gz*
2. Go the directory where the *tar* file was downloaded, and unpack it . The *tar* file is unpacked into a new directory.
3. Go to the newly-created installation directory, and launch the installation script:
`./INSTALL_LUSTRE_2009.1`

This installs Lustre, BrowseD, Wiretap Gateway, and Backburner Manager on the workstation.

4. Install the Wiretap Gateway license. See [“Licensing the Wiretap Gateway”](#) on page 19.
5. Install the Burn package by launching the following installation script on each processing node:
`./INSTALL_LUSTRE_2009.1_BURN`

This installs the Backburner server and Media I/O adapter on each node.

6. Verify that all the components have been properly installed. See [“Verifying Installed Components”](#) on page 20.

Example #2: Lustre Workstation With Separate Wiretap Gateway

In this example, Lustre is running on a Windows or Linux workstation while the Wiretap Gateway resides on a dedicated machine on the network. Media processing is performed by processing nodes bundled in the node groups in a render farm.

Before starting the setup process, you need to determine a location for the Backburner Manager. If your Lustre workstation is the only one serviced by the render farm, you can run Backburner Manager on the workstation itself. If the render farm is shared by multiple workstations, you will need to install and run Backburner Manager on a dedicated machine.

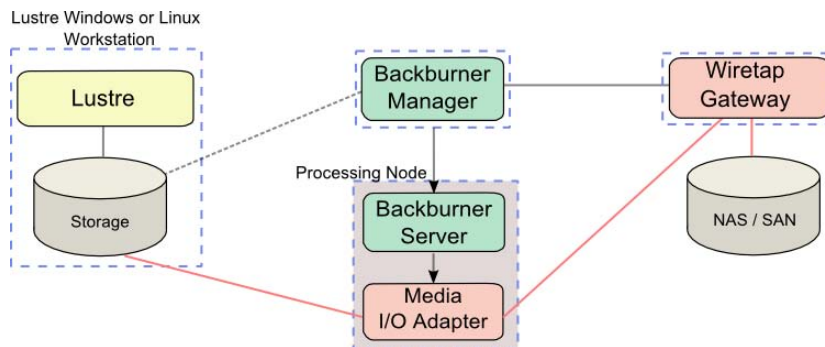

NOTE: Consult the *Autodesk Backburner Installation Guide* for detailed descriptions of Backburner components, and for instructions on designing a render farm that suits your needs.

To install Lustre and Wiretap Gateway on Separate Machines:

- Download one of the following packages: .
 - For Windows: ftp://ftp.discreet.com/pub1/release/lustre/lustre2009/Lustre_2009.1.zip
 - For Linux: ftp://ftp.discreet.com/pub1/release/lustre/lustre2009/Lustre_2009.1.tar.gz
- For Windows, use a compression utility, like Winzip, to uncompress the Lustre package and extract it to a folder on your system.
For Linux, go the directory where the *tar* file was downloaded, and unpack it . The Lustre *tar* file is unpacked into a new directory.
- Install Lustre by doing one of the following:
 - For Windows, go to the folder where the package was extracted and double-click the executable file. This installs Lustre and BrowseD on the workstation.
 - For Linux, go the newly created installation directory and launch the installation script by typing:

```
./INSTALL_LUSTRE_2009.1
```

This installs all the components on the Linux workstation.

4. Install Backburner Manager on a separate machine by launching the following script:

```
./INSTALL_LUSTRE_2009.1_BURN
```

Make sure that only Backburner Manager is run on this machine.

5. Install Wiretap Gateway on a dedicate machine by launching the following script:

```
./INSTALL_WIRETAP_GATEWAY_SERVER
```

NOTE: Wiretap Gateway can only be installed on a Linux machine.

6. Install the Wiretap Gateway license. See [“Licensing the Wiretap Gateway”](#) on page 19.
7. Install the Burn package by launching the following installation script on each processing node:

```
./INSTALL_LUSTRE_2009.1_BURN
```

This installs the Backburner server and Media I/O adapter on each node.

8. Verify that all the components have been properly installed. See [“Verifying Installed Components”](#) on page 20.

Example #3: Incinerator With Wiretap Gateway

In this scenario, Lustre is installed on an Incinerator system, the Wiretap Gateway is installed on the Lustre Media Server, and the processing nodes are on a render farm.

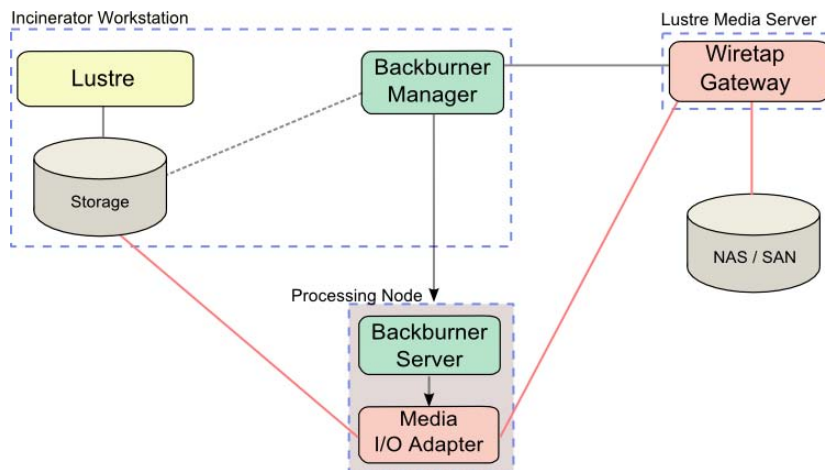

To install Wiretap Gateway with the Incinerator system:

1. Download the Incinerator package from the following location: *ftp://ftp.discreet.com/pub1/release/lustre/lustre2009/Lustre_2009.1.tar.gz*.
2. Go to the directory where the *tar* file was downloaded, and unpack it . The *tar* file is unpacked into a new directory.
3. Go to the newly-created Incinerator installation directory, and launch the installation script:
./INSTALL_LUSTRE_2009.1_INCINERATOR

This installs Lustre and the Backburner Manager on the workstation.

4. Install the server package by launching the following installation script on the LMS:
./INSTALL_LUSTRE_2009.1_SERVER

This installs the Wiretap Gateway, BrowseD, cmanager, and client on the LMS.

5. Install the Wiretap Gateway license. See [“Licensing the Wiretap Gateway”](#) on page 19.
6. Install the render node package by launching the following installation script on each processing node:

./INSTALL_LUSTRE_2009.1_RENDERNODE

This installs the Backburner server, Media I/O adapter, and renderd on each node.

7. Verify that all the components have been properly installed. See [“Verifying Installed Components”](#) on page 20.

Licensing the Wiretap Gateway

You cannot use the Wiretap Gateway until you enter a license code for it. Unlicensed Wiretap Gateway machines are labeled as such in the Lustre file browser.

▶ C:	
▶ D:	
▶ mtispglinux1	Autodesk IFFFS 2009.1.SP2
▶ mtispglinux2	Autodesk Wiretap Gateway Server (Unlicen...
▶ mtispglinux2	Autodesk IFFFS 2010.0.0.beta4
▶ vanier	Autodesk Wiretap Gateway Server (Unlicen...

Although they still appear in the file browser, unlicensed Wiretap Gateways block all media I/O. When you attempt to play or import media through an unlicensed Wiretap Gateway, the operation fails and an “Unlicensed” error message is returned.

Perform the following procedure on each Wiretap Gateway machine to license it.

To license the Wiretap Gateway:

1. Obtain the Discreet host ID of the Wiretap Gateway machine. Open a terminal and type:

```
dlhostid
```

The following line should be part of the output:

```
The Discreet host ID of this machine is
"DLHOST01=25231AEF83AD9D5E9B2FA270DF4F20B1"
```

2. Send the Discreet host ID (including the DLHOST01= part) to the Autodesk Licensing Department to obtain the Wiretap Gateway license code.

You will receive a license code similar to the following:

```
FEATURE wiretapgw_all_2010 discreet_1 2010.999 15-oct-2009 0
\ 4D7A8424FC43E0F86A65 \
```

NOTE: The code above is just an example. Actual license codes are unique for each Wiretap Gateway machine.

3. On the Wiretap Gateway machine, open the file `/usr/local/flexlm/licenses/DL_license.dat` in a text editor (such as `nano`) and enter the license code.

NOTE: Edit this file with care; an incorrect character or missing space may prevent the Wiretap Gateway from recognizing the license.

4. Save and close the `DL_license.dat` file, then restart the Wiretap Gateway by typing:

```
/etc/init.d/wiretapgateway restart
```

5. To verify that the Wiretap Gateway was successfully licensed, launch Lustre and view the file browser in the Edit>Browse menu.

The Wiretap Gateway should no longer contain the mention “Unlicensed”. This verifies that the Wiretap Gateway is installed successfully.

▶ cardigan	Autodesk Wiretap Gateway Server 2010.1
▶ catania	Autodesk Wiretap Gateway Server 2010.0

Verifying Installed Components

After installing and configuring Lustre, and all related components, perform the following procedures to verify that installation was successful.

Verifying the Media I/O Adapter

To verify the Media I/O Adapter installation on a Backburner Server node:

1. Open a shell as root and type the following:

```
rpm -qa |grep mio
```

2. Confirm the file *autodesk.mio.tools-<version_number>.rpm* is present.

Verifying the Render Farm

To verify the Render Farm setup:

1. In Explorer, open Backburner Monitor.
2. Select the Server tab and verify the nodes are displayed.

Wiretap Gateway Configuration File

When working with Wiretap Gateway, there are a couple of settings you may want to change within the configuration file. The configuration file is at the location, */usr/discreet/wiretapgateway/cfg/wiretapgateway.cfg*. These settings are the Server setting and the Proxy resolution.

The default server primary interface is GigE. If you are using Infiniband, you need to define the IP0 value to be the host Infiniband address (e.g., IP0=10.10.11.10).

When viewing the proxy of the RED (R3D) footage, you may want to change its resolution. This can be done in the Red section of the configuration file. The LowresDebayerMode keyword is set to Quarter as the default. You can change the resolution to one of the following:

- Full
- Half Premium
- Half Good
- Quarter
- Eighth

For example, the following system setups should have the LowresDebayerMode keyword set to the following to achieve real-time playback.

Computer	LowresDebayerMode Keyword
IBM Z Pro 6223 with eServer X346 media server	Eighth
HP xw8400 with HP xw9400 media server	Eighth
HP xw8600 with HP xw8600 media server	Quarter

Upgrading the NVIDIA Graphics Card Driver

NOTE: This procedure only applies to Windows systems. On Linux systems, the correct version of the NVIDIA Graphics Card driver is installed automatically by the DKU.

To upgrade your NVIDIA graphics card driver:

1. Download the driver upgrade package to a temporary location on your system.
2. Use a compression utility, like Winzip, to decompress the driver upgrade package and extract it to a folder on your system.
3. Open the folder that contains the upgrade package you extracted and double-click *setup.exe* to start the driver update.

The NVIDIA Install Shield Wizard opens.

4. Click Next to continue the upgrade procedure.
A Hardware Installation warning message appears.
5. Click Continue Anyway.
6. Select Yes, I want to restart my computer now, and click Finish.

After you reboot, the NVIDIA graphics card driver is installed.

dlConfigCheck Utility

The *dlConfigCheck* utility is used to provide you with a list of your workstation configuration (e.g., driver versions, hardware configurations, DKU version, system configurations, etc.).

From this list you can quickly determine if your workstation is set up correctly.

To use the *dlConfigCheck* utility:

1. As root, open a terminal.
2. Type:

```
dlConfigCheck
```

The *dlConfigCheck* utility starts and a list of your workstation configuration is displayed.

Disabling the InfiniBand Sockets Direct Protocol (SDP) Flags

In order to transcode RED media on the Incinerator, you need to disable the InfiniBand SDP flag on the IBM Z Pro 6223 Lustre Media Server (LMS).

NOTE: This procedure is only applicable if your LMS is an IBM Z Pro 6223.

To disable the *ics.sdp* flag on your IBM Z Pro 6223 LMS:

1. Open a shell as root and type:

```
chkconfig ics_sdp off
```

This will turn off all of the *ics.sdp* flags.

2. To verify the flags have been turned off, type:

```
chkconfig --list |grep -i ics_sdp
```

You should see something similar to the following that shows all of the flags have been turned off.

```
ics_sdp 0:off 1:off 2:off 3:off 4:off 5:off 6:off
```

3. Reboot the system for the change to take effect. Type:

```
reboot
```

Reverting Incinerator From Lustre 2009 Extension 1 to a Previous Version

If your Incinerator station is already running a version of Lustre 2009 and you have installed Lustre 2009 Extension 1, you need to run a script on the Lustre Media Server in order to revert from Lustre 2009 Extension 1 to a previous version. The script can be downloaded from the MyFeedback portal.

NOTE: You need to contact Autodesk support (www.autodesk.com/support) in order to obtain the script.

To revert the services from Lustre 2009 Extension 1 to a previous version of Lustre 2009:

- As root, open a terminal and type:

```
sh Incinerator_version_revert.sh
```

The Lustre application is now reverted.

NOTE: For more information with reverting, as root, type: **sh Incinerator_version_revert.sh --help**

Obtaining the Host ID of the Linux Workstation

If you are installing Lustre on an HP xw8600 Linux workstation that has a Visual Effects and Finishing application installed, you need to provide the *dlhostid* in order to request a license code.

To request the host ID:

1. On your workstation, log in using the account for your application, and open a terminal.
2. Run the Discreet host ID utility to display the unique *dlhostid* for the machine. Type:

```
dlhostid
```

A message similar to the following one appears, containing the host ID:

```
dlhostid - Copyright ©2005 by Autodesk, Inc./Autodesk Canada
Co. All rights reserved.
```

```
The lmhost ID of this machine is "00110910DA2E"
```

```
The Discreet host ID of this machine is
"DLHOST01=25231AEF83AD9D5E9B2FA270DF4F20B1"
```

3. Send the Discreet host ID to the Licensing Department to receive your application license code. When you record the Discreet host ID, make sure you include the DLHOST01=string as well as the number; for example,

```
DLHOST01=25231AEF83AD9D5E9B2FA270DF4F20B1
```

NOTE: Make sure you obtain a host ID for each workstation on which you install the application.

Storage Configuration

In order to address certain performance issues, the storage Writeback Cache value needs to be changed for each array. This is a manual operation using the Stone Storage Manager (SSM). This change is non-destructive and will not affect the data contained on the disk arrays.



WARNING: The storage configuration modification needs to be completed on all Lustre 2009 workstations.

To change the Writeback Cache value for the storage:

1. Connect to the Stone Storage Manager (SSM).
2. In the SSM, click on the first array listed in the Arrays section.
3. In the Array panel, confirm the following settings in the Cache Parameters:

Setting:	Value:
Read-Ahead Cache	Automatic
Writeback Cache	256 MB
Mirror cache (Disable Writeback cache when partner controller is missing or failed.	Disabled

Setting:	Value:
Disable Writeback cache if a controller battery is low, missing, or failed.	Enabled
Disable Writeback cache if array becomes critical (N/A for RAID 0).	Enabled
Disable cache Writethrough operation when write cache is full.	Enabled

4. Click Apply.
5. Click Close.
6. Release steps #3-5 for the remaining arrays.
7. Click Close.

Standard VTR and VTR Emulation Control Cable

The following diagram depicts the RS-422 control cable pinouts for the standard VTR control cable.

VTR Control Cable

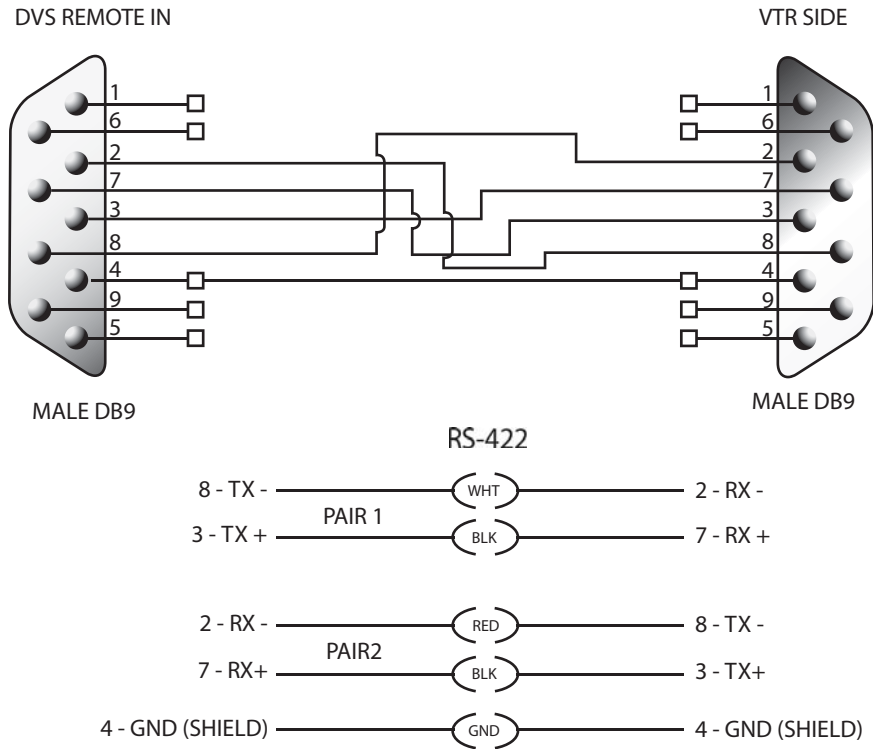

For the emulator mode, you need to use a straight (pin-to-pin) cable as shown in the following diagram.

VTR Control Cable: DVS Controlling VTR (Normal Video I/O Control Cable)

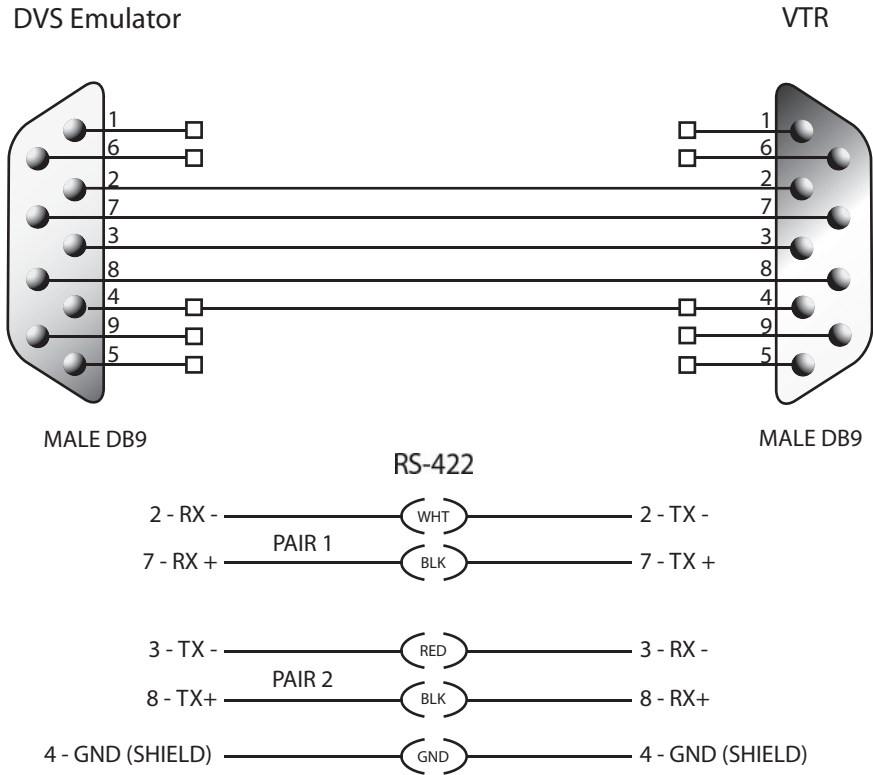

Audio Input and Output

Lustre 2009 introduces new ways to work with audio as well as new audio hardware. A Lucid converter can be used with the new AJA Breakout Box or DVS Centaurus® Breakout Box. For more information about the audio hardware and connection, refer to your *Lustre Hardware Setup Guide*.

Autodesk Control Surface Panel

The home folder contains some control panel files that you can use. These following files are:

- **cp100_default.rules** — Factory default panel file for the CP-100.
- **acs_default.rules** — Factory default panel file for the Autodesk Control Surface (ACS).
- **acs_video.rules** — This file has more sensitive controls for the ACS.

There are a few different ways which you can use these files, but the most common are as follows:

- Modifying the *acs.rules* or *cp100.rules* file within your user folder to your preference. See [“Modifying the User Rules File”](#) on page 28.
- Modifying the default *acs.rules* or *cp100.rules* file within the home folder. See [“Modifying the Default Rules File”](#) on page 28.

Modifying the User Rules File

When you create a new user configuration within the Lustre application, a copy of the *acs.rules* or *cp100.rules* file is copied into your user folder. You can edit this file so your control panel settings are to your preference.

Modifying the Default Rules File

It is possible for you to modify the default *acs.rules* or *cp100.rules* file if you are not pleased with the settings that the current default file provides. To modify the rules file so the modified default settings are used for every new user configuration which is created, modify the *acs.rules* or *cp100.rules* file within the home folder.

Configuration Files

In Lustre 2009, the configuration files are very different from previous versions. Please pay close attention to the *init.config* file.

This file is now used to set the system level settings, like the following:

- Wiretap server auto detection
- Wiretap server IP address
- BrowseD configuration
- System level keywords

The following configuration files are now part of the *init.config* file:

- *wt.config*
- *filmtypes.config*

- *browsed.config*

The location of project and user settings has also changed. Their new locations are:

- *C:/Autodesk/Projects* (Windows)
- *C:/Autodesk/Users* (Windows)
- *usr/autodesk/projects* (Linux)
- *usr/autodesk/users* (Linux)

init.config File



WARNING: When updating to Lustre 2009 Extension 1 on the Linux workstation, you need to back up the *init.config* file before updating.

The following updates have been made to the *init.config* file.

Parameter	Data type	Default	Function
<Browsed>			
<Port>	Integer	1055	All computers on the BrowseD network must use the same port to communicate. Use the default value for Windows and Linux over IB. For Linux over IP, set the value to 1044.
<Miscellaneous>			
<ChangeCutOffset>	State	On	Allows the change cut or match grade feature to preserve the keyframe animations based on the record timecode whenever a shot has been replaced or moved within a timeline. NOTE: Be sure to enabled only the Record button within the Match Option when performing a change cut or match grade.

Upgrade Compatibility

You can use project content, like grades, cuts, presets, and so on, created in Lustre 2008/2007 in Lustre 2009 Extension 1, but you should always copy the material from the previous release to a new project of Lustre 2009 Extension 1.

For instructions on carrying forward project data for Lustre on a Linux workstation, see [“Lustre on a Linux Workstation”](#) on page 32.

Wiretap Interoperability

Lustre 2009 Extension 1 is read/write compatible with Wiretap 2008, 2009, and 2009 Extension 1. Lustre 2009 Extension 1 can only read and write media to a project that is the same version as the Wiretap server.

The following is a table of Lustre 2009 read and write capabilities if Wiretap server 2009 Extension 1 is running.

Lustre 2009 read / write capability	Version of Visual Effects and Finishing project
Read and write	Visual Effects and Finishing 2009 Extension 1 projects
Read only	Visual Effects and Finishing 2007/2008/2009 projects

SDP over Infiniband Support

To be able to have a high speed IB connection, you need to install the latest Windows IB driver on the Lustre workstation and the latest Linux IB driver on the Visual Effects and Finishing workstation. You will need the following:

- Lustre 2008 Service Pack 2 or higher
- Autodesk® Smoke® or Autodesk® Flame® 2008 Service Pack 4 or higher (with DKU version 3.5.0)

NOTE: For details on how to acquire the correct drivers, firmware, and utilities and how to upgrade your switch firmware, contact your local Autodesk support office. See [“Contacting Customer Support”](#) on page 4.

Lustre 2009 Extension 1 supports a socket direct protocol (SDP) over IB connection in addition to the continued support of the IP over IB connection. The performance advantage of the SDP over IB solution is the ability to transfer up to 2K 10-bit source footage in real-time over Wiretap.

For SDP over IB support, the Visual Effects and Finishing application your Lustre workstation connects to must be either Smoke or Flame 2008 Service Pack 4 or 2009 with the latest DKU (the latest DKU has the new IB driver). For full details about Smoke or Flame requirements, see the Release Notes for Smoke or Flame 2008 Service Pack 4 or higher.

NOTE: If using an SDP over IB connection and you choose to manually configure specific Wiretap servers in the *init.config* file, make sure you input the Gigabit Ethernet IP addresses of the Wiretap host machines and not the Infiniband IP addresses.

User Guide Addendum



Summary

Overview	31
Softness Scale for Colour Isolation	31
Features No Longer Used in Lustre	32
Limitations for Lustre 2009	32
Lustre on a Linux Workstation	32
Telecine-mode Playout	32
Wiretap	33

Overview

This chapter contains a collection of late additions to the *Lustre User Guide*.

Softness Scale for Colour Isolation

In User Settings, you can adjust the scale of the Softness Diamond on the hue cube for the Diamond Keyer.

NOTE: This new option is available in Lustre 2009 Extension 1.

To adjust the scale of the Softness Diamond:

1. Navigate to the Tools menu in the User Configuration.

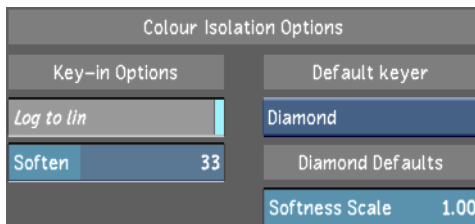

2. In the Colour Isolation Options menu, click and drag the mouse cursor in the Softness Scale field to decrease or increase the range of softness on the hue cube.

Features No Longer Used in Lustre

The DDR Chase feature is no longer available on systems with DVS, and the automatic pulldown detection feature is no longer available on systems with DVS.

Limitations for Lustre 2009

The Timeline Sort mode and Collapse view are not available when you are working in Stereoscopy mode.

Lustre on a Linux Workstation

When you are installing the Lustre 2009 Extension 1 software on Linux, a Lustre user is created. Since project data was created as Root in previous Lustre releases, you have to change the file permission for all your project folders in order to use them with Lustre 2009.

To use your previous project data with Lustre 2009:

1. Log in as root.
2. Install Lustre 2009.
3. Log in as Lustre user (you will see a Lustre 2009 icon on the login page)

NOTE: A password is not needed to log in.

4. Start Lustre by clicking the Lustre icon or by typing Lustre in a shell.
5. Navigate to your project folders.
6. As root, type in the shell:

```
chmod 777 *
```

The project files and folders can now be read/written using Lustre 2009. Repeat steps 5 and 6 for your scans and render folders.

Telecine-mode Playout

The Telecine-mode playout is now available on both the DVS and AJA systems. You can only create a Telecine tape in Assemble mode (Insert and Record mode are not available). You can perform a Telecine-mode Playout from the Print view (P) or the Output view (O) if you enable

the *Playout From Timeline* option. In Lustre 2009 you will not use the LTC Out from the DVS to feed the timecode to the VTR; instead you will use the RS-422.

NOTE: Since it is not possible to playout, with the Telecine-mode, shots with retime effects, you need to use the timeline sort mode feature before performing the playout. This will output the graded source media without the retime effect.

To perform a Telecine-mode Playout:

1. Set the VTR Timecode Generator to Internal / Preset.
2. Do one of the following:
 - If you are using a Digital Betacam, set the VTR menu Regen Mode (610) to Manual.
 - If you are using an HDCam or HD-D5, the Regen mode is set to Automatic by default. You do not need to change anything.
3. Grade your timeline.
4. Use the Editing > Assemble > Timeline Sort Mode tool to sort your timeline in C-mode (with or without heads and tails).
5. If you intend to use the Print view for playout, render the media, but if you intend to use the Output view, enable the *Playout From Timeline*.

NOTE: You can also use the RealTime Deliverables view (D).
6. In the Editing > Playout menu, enable Telecine-mode.
7. Set the duration of the Black media that is added before each shot (default is five seconds).
8. Set the Start Timecode.
9. Press Assemble.

Wiretap

The following are the updates to Wiretap and the Wiretap workflow.

Wiretap Command Line Tools

The Wiretap command line tools are available in the tools folder of the Lustre application.

For more information about the command line tools, refer to the *Autodesk Wiretap SDK Developer Guide*.

Timewarp from Smoke or Flame

There is an optimization of the timewarp processing in Smoke and Flame that causes problems with Lustre. When processing a timewarp speed that does repeat the same media (e.g., 0%, 50%, etc.) the same media is repeated. This makes the timewarp processing faster, but shows the timewarped shots as single frame edit result in Lustre. To disable the timewarp processing option, type the following environment variable before launching Smoke or Flame:

```
setenv DL_DISABLE_NOOP_SOFT_FX_OPTIMISATION
```

The default state of the variable is OFF, meaning that by default the optimization is enabled in Smoke and Flame, and Lustre will be given a single-frame edit for any timewarp shot. If there is a problem when you are loading a timeline in Lustre, you need to exit Smoke or Flame, set the environment variable as shown above, and process in Smoke or Flame. Next, reload the timeline in Lustre.

NOTE: This is only available with Smoke and Flame 2009 Extension 1.

Publish

When working with Smoke or Flame over Wiretap, it is possible to use published content. If you intend to generate local proxies for Wiretap content, make sure the Publish operation in Smoke or Flame is performed with the following options:

- Select the Flatten Publish option.
- Set the Type option to Media+EDL.
- Set the Output Format to DPX.
- Set the File Naming option to Use Clip Timecode.
- Set the Head/Tail option.
- Select the Create Sub Directories option.
- Set the Destination path to a shared storage (e.g., NAS or SAN).
- Enable the Link option if the source media is located on the same destination file system.

This will avoid duplication of media.

Once all the options have been set, click Publish.

File Naming is a new option in Smoke and Flame 2009 Extension 1. It allows you to define how the file name of the published media is created.

- <timeline name>_<shot name>_<frame>.dpx (use clip name)
- <source timecode>.dpx (use clip timecode)
- <timeline name>_<shot name>_<source timecode>.dpx (use both)

Since Lustre uses the filename to generate the local proxy, you have to select the Use Clip Timecode option. With this option, the proxy media will always be referenced by Lustre even if the structure of the timeline changes. The Use Clip Name option changes the shot name based on the timeline position of the shot (e.g., shot1, shot2, etc.)

Installation Documentation Workflows



Summary

Overview	37
Reinstalling from Scratch	37
Connecting New or Expanded Stone Direct Storage	38
Upgrading Lustre	39
Documentation FAQs	39

Overview

Your Autodesk Lustre 2009 system is shipped preconfigured with the appropriate operating system and application already installed. In normal situations, the final configuration procedures are simple and well documented.

This chapter highlights four common installation workflows that you may need to perform, and lists the documentation relevant to each. You should always identify and gather the relevant documentation before proceeding with any installation workflow.

Reinstalling from Scratch

Follow this workflow when you need to completely rebuild your Lustre system: from cross-connecting the hardware peripherals and storage arrays, to installing the operating system, and installing, licensing, and configuring your application.

To reinstall your system from scratch:

1. Prepare for the installation.
Consult the latest *Autodesk Lustre Release Notes* (web version) for the latest requirements and late-breaking information.
2. Connect the hardware peripherals to the workstation.
Consult the *Hardware Setup Guide* for your workstation.

3. Connect your storage.

Consult the *Autodesk Lustre 2009 Extension 1 Installation and Configuration Guide for Linux Workstations*, or the *Autodesk Stone Direct Configuration Guide*.

4. Install the operating system.

For Windows workstations, consult the *Autodesk Lustre 2009 Software Installation Guide for Windows Workstations*.

For Linux workstations, consult the *Autodesk Lustre 2009 Extension 1 Installation and Configuration Guide for Linux Workstations* or *Autodesk Incinerator 2009 Installation and User Guide*.

5. Configure the RAID volumes and mount the storage.

Consult the *Autodesk Lustre 2009 Extension 1 Installation and Configuration Guide for Linux Workstations*, or the *Autodesk Stone Direct Configuration Guide* for your release.

6. Install and license Lustre.

For Linux workstations, consult the *Autodesk Lustre 2009 Extension 1 Installation and Configuration Guide for Linux Workstations*, the *Autodesk Incinerator 2009 Installation and User Guide*, or the *Autodesk Lustre 2009 Software Installation Guide for Windows Workstations*.

7. Get going.

Read the *Autodesk Lustre 2009 Extension 1 User Guide* and *Autodesk Lustre 2009 Extension 1 New Features Guide* to get familiar with Lustre's powerful features.

Connecting New or Expanded Stone Direct Storage

Follow this workflow when you need to rebuild your Autodesk workstation's Stone Direct storage array. For instance, this may be required when you purchase supplementary storage enclosures to expand available disk space.

To connect new or expanded Stone Direct storage:

1. Prepare for the installation.

Consult the latest *Autodesk Lustre Release Notes* (web version) for the latest requirements and late-breaking information.

2. Connect your storage.

Consult the *Autodesk Lustre 2009 Extension 1 Installation and Configuration Guide for Linux Workstations*, or the *Autodesk Stone Direct Configuration Guide* for your release.

3. Configure the RAID volumes and mount the storage.

Consult the *Autodesk Lustre 2009 Extension 1 Installation and Configuration Guide for Linux Workstations*, or the *Autodesk Stone Direct Configuration Guide* for your release.

4. Configure your filesystem.

Consult the *Autodesk Lustre 2009 Extension 1 Installation and Configuration Guide for Linux Workstations*, or the *Autodesk Lustre 2009 Software Installation Guide for Windows Workstations*.

5. Begin working with Lustre.

Read the *Autodesk Lustre 2009 Extension 1 User Guide* and *Autodesk Lustre 2009 Extension 1 New Features Guide* to get familiar with your application's powerful features.

Upgrading Lustre

Follow this workflow in cases where you need to install or upgrade your application. Typically, you do not have to reformat the filesystem or upgrade the operating system when you upgrade the application.

To upgrade your application:

1. Prepare for the installation.

Consult the *Autodesk Lustre Release Notes* (web version) for the latest requirements and late-breaking information.

2. Install and license your application.

Consult the *Autodesk Lustre 2009 Extension 1 Installation and Configuration Guide for Linux Workstations*, or the *Autodesk Lustre 2009 Software Installation Guide for Windows Workstations*.

3. Begin working with Lustre.

Read the *Autodesk Lustre 2009 Extension 1 User Guide* and *Autodesk Lustre 2009 Extension 1 New Features Guide* to get familiar with your application's powerful features.

Documentation FAQs

Here are a few examples of common installation enquiries, and the documentation that provides the answers to each.

How Do I Request a License for Lustre?

Consult the *Autodesk Lustre 2009 Extension 1 Installation and Configuration Guide for Linux Workstations*, or the *Autodesk Lustre 2009 Software Installation Guide for Windows Workstations*

for installation procedures and information on obtaining and installing the licenses required to launch your application.

How Do I Learn About the Latest Updates?

Consult the latest *Autodesk Lustre Release Notes* (web version). They contain the most current information about requirements and procedures.

How Do I Find Out About All the New Features for This Release?

Read the *Autodesk Lustre 2009 Extension 1 New Features Guide* for an overview of new features. For complete new feature information, consult the *Autodesk Lustre 2009 Extension 1 User Guide*.