

Autodesk®
Lustre® 2009

A Discreet® Systems product

Release Notes Service Pack 7



Autodesk®

© 2009 Autodesk, Inc. All rights reserved. Except as otherwise permitted by Autodesk, Inc., this publication, or parts thereof, may not be reproduced in any form, by any method, for any purpose.

Certain materials included in this publication are reprinted with the permission of the copyright holder.

The following are registered trademarks or trademarks of Autodesk, Inc., in the USA and other countries: 3DEC (design/logo), 3December, 3December.com, 3ds Max, ADI, Alias, Alias (swirl design/logo), AliasStudio, Alias|Wavefront (design/logo), ATC, AUGI, AutoCAD, AutoCAD Learning Assistance, AutoCAD LT, AutoCAD Simulator, AutoCAD SQL Extension, AutoCAD SQL Interface, Autodesk, Autodesk Envision, Autodesk Insight, Autodesk Intent, Autodesk Inventor, Autodesk Map, Autodesk MapGuide, Autodesk Streamline, AutoLISP, AutoSnap, AutoSketch, AutoTrack, Backdraft, Built with ObjectARX (logo), Burn, Buzzsaw, CAiCE, Can You Imagine, Character Studio, Cinestream, Civil 3D, Cleaner, Cleaner Central, ClearScale, Colour Warper, Combustion, Communication Specification, Constructware, Content Explorer, Create>what's>Next> (design/logo), Dancing Baby (image), DesignCenter, Design Doctor, Designer's Toolkit, DesignKids, DesignProf, DesignServer, DesignStudio, Design|Studio (design/logo), Design Web Format, Discreet, DWF, DWG, DWG (logo), DWG Extreme, DWG TrueConvert, DWG TrueView, DXF, Ecotect, Exposure, Extending the Design Team, Face Robot, FBX, Filmbox, Fire, Flame, Flint, FMDesktop, Freewheel, Frost, GDX Driver, Gmax, Green Building Studio, Heads-up Design, Heidi, HumanIK, IDEA Server, i-drop, ImageModeler, iMOUT, Incinerator, Inferno, Inventor, Inventor LT, Kaydara, Kaydara (design/logo), Kynapse, Kynogon, LandXplorer, LocationLogic, Lustre, Matchmover, Maya, Mechanical Desktop, Moonbox, MotionBuilder, Movimento, Mudbox, NavisWorks, ObjectARX, ObjectDBX, Open Reality, Opticore, Opticore Opus, PolarSnap, PortfolioWall, Powered with Autodesk Technology, Productstream, ProjectPoint, ProMaterials, RasterDWG, Reactor, RealDWG, Real-time Roto, REALVIZ, Recognize, Render Queue, Retimer.Reveal, Revit, Showcase, ShowMotion, SketchBook, Smoke, Softimage, Softimage|XSI (design/logo), SteeringWheels, Stitcher, Stone, StudioTools, Topobase, Toxik, TrustedDWG, ViewCube, Visual, Visual Construction, Visual Drainage, Visual Landscape, Visual Survey, Visual Toolbox, Visual LISP, Voice Reality, Volo, Vtour, Wire, Wiretap, WiretapCentral, XSI, and XSI (design/logo).

The following are registered trademarks or trademarks of Autodesk Canada Co. in the USA and/or Canada and other countries: Backburner, Multi-Master Editing, River, and Sparks.

The following are registered trademarks or trademarks of Moldflow Corp. in the USA and/or other countries: Moldflow MPA, MPA (design/logo), Moldflow Plastics Advisers, MPI, MPI (design/logo), Moldflow Plastics Insight, MPX, MPX (design/logo), Moldflow Plastics Xpert.

All other brand names, product names or trademarks belong to their respective holders.

Disclaimer

THIS PUBLICATION AND THE INFORMATION CONTAINED HEREIN IS MADE AVAILABLE BY AUTODESK, INC. "AS IS." AUTODESK, INC. DISCLAIMS ALL WARRANTIES, EITHER EXPRESS OR IMPLIED, INCLUDING BUT NOT LIMITED TO ANY IMPLIED WARRANTIES OF MERCHANTABILITY OR FITNESS FOR A PARTICULAR PURPOSE REGARDING THESE MATERIALS.

Title: Autodesk Lustre 2009 Service Pack 7 Release Notes

Document Version: 1

Date: August 1, 2009

contents

Contents

1	Release Information	1
	Summary	1
	About These Release Notes	1
	Related Documentation	1
	Accessing Online Help	2
	Accessing PDF Documentation	3
	Fixed and Known Bugs	4
	Contacting Customer Support	4
2	System Information	5
	Overview of New and Updated Sections	5
	Do I Need to Install SP7?	7
	Software Versions and Associated Platforms	7
	Release Requirements	7
	Hardware System Requirements	7
	Discreet Kernel Utilities (DKU) 4.0.5 Required	8
	Introducing HP ProLiant DL160se G6 Incinerator Nodes	9
	Items No Longer Supported as of Lustre 2009	10
	Configuring the Memory Allocation	10
	Using the /3GB Startup Switch to Increase Virtual Address Space	10
	Adding 1GB RAM to the IBM 6223	12
	dlConfigCheck Utility	13
	Obtaining the Host ID of the Linux Workstation	13
	Obtaining the dlhostid	14
	Storage Configuration	15

Standard VTR and VTR Emulation Control Cable.....	15
Audio Input and Output	17
Autodesk Control Surface Panel	18
Modifying the User Rules File	18
Modifying the Default Rules File	18
Configuration Files.....	18
init.config File	19
Upgrade Compatibility	19
Wiretap Interoperability	20
SDP over Infiniband Support	20

3 Installation Documentation Workflows 23

Documentation FAQs	25
How Do I Request a License for Lustre?	25
How Do I Learn About the Latest Updates?	25
How Do I Find Out About All the New Features for This Release?	25

4 User Guide Addendum 27

Telecine-mode Payout	28
Wiretap.....	29
Wiretap Command Line Tools	29
Timewarp from Smoke or Flame	29
Publish	30



Release Information

Summary

About These Release Notes	1
Related Documentation	1
Fixed and Known Bugs	4
Contacting Customer Support	4

About These Release Notes

The chapters in this document provide a concise collection of important release information about Autodesk® Lustre® 2009 Service Pack 7.

[Chapter 1, "Release Information,"](#) on page 1 - Provides information about related documentation and contacting customer support.

[Chapter 2, "System Information,"](#) on page 5 - Provides infrastructure and hardware-related information.

[Chapter 4, "User Guide Addendum,"](#) on page 27 - Provides new information that was released after the user guide went to print.

[Chapter 3, "Installation Documentation Workflows,"](#) on page 23 - Provides common installation workflows, such as reinstalling from scratch or upgrading your application.

Check the Web site for the most up-to-date version of these *Release Notes*.

Related Documentation

The following table describes the documentation associated with your application.

User Guides	Provides
<i>Autodesk Lustre 2009 User Guide</i>	Detailed instructions on using the software.
<i>Autodesk Control Surface User Guide</i>	Detailed instructions on using the Autodesk control surface and the Tangent CP100.

User Guides	Provides
<i>Autodesk Lustre 2009 New Features Guide</i>	Information about the new features for this release.
<i>Autodesk Lustre 2009 Hot Keys Card</i>	A list of the most frequently used hot keys.
<i>Autodesk Lustre 2009 Service Pack 7 Release Notes</i>	A complete list of documentation and information on late-breaking features.
<i>Autodesk Lustre 2009 Service Pack 7 Fixed and Known Bug List</i>	A complete list of fixed and known bugs for this release.
Installation and Configuration Guides	Provides
<i>Hardware Setup Guide (for your workstation)</i>	Information on how to setup your workstation and video I/O peripherals.
<i>Stone Direct Configuration Guide</i>	Provides detailed connectivity diagrams and configuration procedures for your Autodesk® Stone® storage arrays.
<i>Stone and Wire Filesystem and Networking Guide</i>	Procedures for configuring your Autodesk® Wiretap® services.
<i>Autodesk Lustre 2009 Software Installation Guide (for your operating system)</i>	Information about installing and licensing your Autodesk Lustre software.
<i>Red Hat Enterprise Linux Workstation Installation and Configuration Guide</i>	Information on how to install and configuration the Linux® operating system on your workstation, should you require to do so.
<i>Autodesk Incinerator 2009 Installation and User Guide</i>	Information on installing, licensing, and using Autodesk® Incinerator®.
Other Guides	Provides
<i>Autodesk Lustre Sparks API Reference Guide</i>	Instructions for developing Sparks® plugins for Lustre.
<i>Autodesk Backburner 2008.1 Installation Guide</i> <i>Autodesk Backburner 2008.1 User Guide</i>	Information on how to install, set up, and use Autodesk® Backburner™.

Consult the Autodesk Web site at www.autodesk.com/lustre-documentation for the latest version of guides, release notes, and fixed and known bugs documents.

Accessing Online Help

Autodesk provides complete documentation in an accessible HTML help system that is displayed in a Web browser. The Help is automatically installed unless specified otherwise during the software installation. Refer to the *Autodesk Lustre Software Installation Guide* for this release.

You can install the Help on another system without installing Lustre. For Windows®, select only Online Help when prompted to select components in the Lustre Installer. For Linux®, you can copy the *Documentation/help* directory from the CD onto another workstation.

To start the help system from Lustre:

- Click the Help button, located in the lower-right corner of all menus, or press **SHIFT+F1**.



To start the help system from the desktop:

1. If using the Windows version of Lustre, choose Start | Programs | Autodesk | Lustre<version number> | Online Help from the Windows task bar.
The Help appears in a browser window.
2. If using the Linux version of Lustre, open a shell and type:

```
<browser> /usr/autodesk/lustre<version number>/help/html/_start-helpsystem.html
```

 (where <browser> is either 'mozilla' or 'firefox', as required.)

To copy the Help to another system:

1. Copy the *Documentation/help* directory from the software CD-ROM to the new location on another system.
2. To start the Help after you copy the help directory, open the *help/html/_start_helpsystem.html* file.

Accessing PDF Documentation

The complete documentation set is available in PDF (Portable Document Format) for online viewing and printing. On Windows and Linux systems, use Adobe® Acrobat® Reader™ to view and print the PDF files. You can access the PDF files from the Lustre software CD or from www.autodesk.com/lustre-documentation.

NOTE: If you do not have Acrobat Reader, you can download a free copy from the Adobe Web site (www.adobe.com).

From the Lustre Application CD

You can view and print the PDF files from the Lustre CD using Adobe Acrobat Reader. All PDF files are located in a directory called *Documentation* at the top level of the CD.

To view the PDF files on the application CD:

1. Place the Lustre CD in the CD-ROM drive of your system.
2. If using the Windows version of Lustre, in Windows Explorer, go to the *Documentation* folder on the CD.
3. If using the Linux version of Lustre, open a Linux shell and navigate to the online help directory. Type:

```
cd /usr/autodesk/lustre<version number>/documentation
```

4. To view a PDF file, do one of the following:

- If using the Windows version of Lustre, double-click the desired file.
- If using the Linux version of Lustre, type:

```
xpdf <filename>
```

The file opens in Acrobat Reader or the Xpdf viewer.

Fixed and Known Bugs

For a list of fixed and known bugs for this release, see the PDF file *lustre2009_sp7_fixed_known_bugs.pdf*. This PDF file is available on the Web only, at www.autodesk.com/lustre-documentation.

Contacting Customer Support

A list of contact information for Autodesk Media and Entertainment Customer Support is available at www.autodesk.com/support.

Customer support is also available through your Autodesk reseller. To find a reseller near you, consult the reseller look-up database on the Autodesk web site at www.autodesk.com/resellers.

System Information



Summary

Overview of New and Updated Sections	5
Do I Need to Install SP7?	7
Software Versions and Associated Platforms	7
Release Requirements	7
Introducing HP ProLiant DL160se G6 Incinerator Nodes	9
Items No Longer Supported as of Lustre 2009	10
Configuring the Memory Allocation	10
dlConfigCheck Utility	13
Obtaining the Host ID of the Linux Workstation	13
Storage Configuration	15
Standard VTR and VTR Emulation Control Cable	15
Audio Input and Output	17
Autodesk Control Surface Panel	18
Configuration Files	18
Upgrade Compatibility	19
Wiretap Interoperability	20
SDP over Infiniband Support	20

Overview of New and Updated Sections

This chapter highlights important notes and procedures related to installation and hardware configuration.



WARNING: Back up the *init.config* file before updating updating to Lustre 2009 Service Pack 7 on Linux workstations.

New changes for Lustre 2009 Service Pack 7:

For Linux platforms:

- HP ProLiant DL160se G6 hardware platforms running Red Hat Enterprise Linux 5.3 are now supported as Incinerator nodes. See [“Introducing HP ProLiant DL160se G6 Incinerator Nodes”](#) on page 9.
- A new DKU (version 4.0.5) is available. This DKU introduces support for the HP DL160se G6 Incinerator nodes. See [“Discreet Kernel Utilities \(DKU\) 4.0.5 Required”](#) on page 8.

New changes to Lustre 2009 Service Pack 6 are as follows:

For the HP Z800 platform:

- A bug that prevented the use of DLHOSTID-based licenses on HP Z800 systems has been fixed. See the latest *Autodesk Lustre 2009 SP6 Fixed and Known Bugs List* for a complete list of bugs fixed in SP6. This document is available from your Lustre installation package, as well as online at www.autodesk.com/me-documentation

New changes to Lustre 2009 Service Pack 5 are as follows:

For all platforms:

- A number of bugs impacting both Windows and Linux systems were fixed in this service pack. It is recommended to upgrade your systems to this service pack (and to the new DKU for Linux users) to benefit from these fixes.

See the latest *Autodesk Lustre 2009 SP5 Fixed and Known Bugs List* for a complete list of bugs fixed in SP5. This document is available from your Lustre installation package, as well as online at www.autodesk.com/me-documentation.

For the Linux platform:

- A New HP® hardware platform (HP Z800) is available for Linux users, featuring the NVIDIA® Quadro® FX5800 graphics card, and the ATTO Celerity FC-84EN 8Gigabit fibre channel host adapter. This workstation works only with the new Red Hat® Enterprise Linux® 5.3 operating system. See [“Lustre Master, Lustre HD, and Lustre Station - Linux Stand-alone”](#) on page 8.
- Red Hat Enterprise Linux 5.3 is now available for the HP Z800 workstation. This is the only operating system supported on the HP Z800 platform, and is not supported on other workstations. See [“Software Versions and Associated Platforms”](#) on page 7.

New changes to Lustre 2009 Service Pack 2 are as follows:

For the Linux platform:

- Procedure for using the *dlConfigCheck* utility. See [“dlConfigCheck Utility”](#) on page 13.

New changes to Lustre 2009 Service Pack 1 are as follows:

For the Linux platform:

- Updating the procedure for obtaining the lmhostid. See [“Obtaining the Host ID of the Linux Workstation”](#) on page 13.
- Obtaining a dlhostid for Lustre Linux (not Incinerator) HP xw8600 workstations that are also running a Visual Effects and Finishing application. See [“Obtaining the dlhostid”](#) on page 14.

For both the Linux and Windows platforms:

- Updating the storage configuration for all Windows and Linux platforms. See [“Storage Configuration”](#) on page 15.
- Standard VTR and VTR emulation control cable pinout for the HP xw8400 and the IBM Z Pro 6223 workstations. See [“Standard VTR and VTR Emulation Control Cable”](#) on page 15.
- Updates to the *init.config* file. See [“init.config File”](#) on page 19.

Do I Need to Install SP7?

Although this service pack will work correctly on all supported platforms, it contains no defect fixes and is intended only for the support of Incinerator on the HP z800 with HP DL160se G6 render nodes.

Software Versions and Associated Platforms

This release of Lustre 2009 Service Pack 7 is available for the Windows® XP SP2 platform, the Red Hat Enterprise Linux 5.3 with Workstation Option (only on HP Z800 workstations, HP Z800 Lustre Media Servers and HP DL160se G6 Incinerator nodes), and for Red Hat Enterprise Linux Workstation 4 Update 3 (for other supported hardware platforms).

Release Requirements

NOTE: Autodesk recommends archiving your media and project data before upgrading the software.

Hardware System Requirements

The following platform configurations are supported for Lustre 2009 Service Pack 7.

Lustre Master, Lustre HD, and Lustre Station - Windows

Computer	Graphics Card	Graphics Driver	VIO
IBM® Z Pro 6223	NVIDIA Quadro FX5500 + SDI	165.46	DVS
HP xw8400	NVIDIA Quadro FX5500 + SDI	165.46	DVS
HP xw8600	NVIDIA Quadro FX5600 + SDI	165.46	AJA

Lustre Master, Lustre HD, and Lustre Station - Linux Stand-alone

Computer	Graphics Card	Graphics Driver	VIO
HP Z800	NVIDIA Quadro FX 5800	180.61	AJA
HP xw8400	NVIDIA Quadro FX5500 + SDI	165.33.18	DVS
HP xw8600	NVIDIA Quadro FX5600 + SDI	165.33.18	AJA

Lustre Master Station and Lustre Station - Linux (with Incinerator)

Computer	Graphics Card	Lustre Media Server	Incinerator Nodes	VIO	Storage
HP Z800	NVIDIA Quadro FX 5800	HP Z800	HP ProLiant DL160se G6	AJA	Autodesk Stone Direct XR-series
HP xw8600	NVIDIA Quadro FX5600 + SDI	HP xw8600	HP ProLiant DL160 G5	AJA	Autodesk Stone Direct XR-series
HP xw8400	NVIDIA Quadro FX5500 + SDI	HP xw9400	HP ProLiant DL140 G3	DVS	Autodesk Stone Direct XR-series
IBM Z Pro 6223	NVIDIA Quadro FX5500 + SDI	IBM eServer X346	IBM eServer X336	DVS	Autodesk Stone Direct IR-series

- Discreet Kernel Utilities 4.0.4 for Linux platforms.

NOTE: The cabling for the DVS has changed since Lustre 2008. Refer to [“Standard VTR and VTR Emulation Control Cable”](#) on page 15.

Discreet Kernel Utilities (DKU) 4.0.5 Required

You must install the Discreet Kernel Utilities (DKU) 4.0.5 before installing or upgrading to Lustre 2009 Service Pack 7 (Linux). The new DKU installs the latest Discreet customized kernel, and a new NVIDIA graphics card driver.

The DKU must be installed on all Incinerator components including the Workstation, the Media Server, and the Incinerator nodes.

To install the DKU from a tar file:

1. Download the DKU *tar* file from Autodesk. The download link is provided in the Service Pack Release Announcement you received from Autodesk.

2. Go to the directory where the *tar* file was downloaded, and unpack it by typing:

```
tar -zxvf DKU_4.0.5.tar.gz
```

The DKU *tar* file is unpacked into a new directory.

3. Go to the newly created DKU installation directory and launch the DKU installation script:

```
./INSTALL_DKU
```

4. Wait for the DKU installation script to complete.

NOTE: When the script completes for the Lustre workstation, a warning appears to update the AJA board, and you are returned to the command prompt.

5. Before rebooting the system, if any storage device (external disk arrays or internal storage) were previously disconnected as part of an operating system installation, reconnect them and power them up.

NOTE: Wait for all the disks in the storage devices to power up before restarting the system. The green light for each disk stops flashing once it is fully powered up.

6. Reboot the system. Type:

```
reboot
```

7. After you install the DKU, as root, run the *dlConfigCheck* script to ensure all firmware and drivers are current. See [“dlConfigCheck Utility”](#) on page 23.

Introducing HP ProLiant DL160se G6 Incinerator Nodes

Service Pack 7 introduces the new HP ProLiant DL160se G6 Incinerator nodes, running the custom Autodesk distribution of Red Hat Enterprise Linux Desktop 5.3.

DL160se G6 Incinerator nodes can only be used with a Lustre Media Server running on a HP Z800 hardware platform.

For information about setting up the hardware, installing Linux and the Incinerator software on the new nodes, consult the latest *Autodesk Incinerator 2009 Installation and User Guide*, available at www.autodesk.com/lustre-documentation.

Items No Longer Supported as of Lustre 2009

In this release, the following item is no longer supported in Lustre configurations:

- NVIDIA® FX4000 SDI PCI-E graphics card.

Configuring the Memory Allocation

To make sure your system is operating at its potential, you need to complete the following:

- Increase the user-mode processes (e.g., applications) virtual address space by using a /3GB startup switch.

NOTE: This is necessary for both the IBM IntelliStation ZPro 6223 and HP xw8400 workstation.

Using the /3GB Startup Switch to Increase Virtual Address Space

Windows uses 4GB of virtual address space. 2GB is allocated to user-mode processes (e.g., applications), while the other 2GB is allocated to kernel-mode processes (e.g., the operating system). The /3GB startup switch allows the memory for the applications to increase to 3GB while reducing the memory for the operating system to 1GB. This increases the speed of your application.

NOTE: This procedure applies to the Windows platform only. In order to complete this upgrade, your system must be running Windows XP Professional Service Pack 2.

To set up the /3GB switch:

1. Click Start>Settings>Control Panel.
2. In the Control Panel window, double-click on Systems.
3. In the Advanced tab, click the Settings button in the Startup and Recovery group.

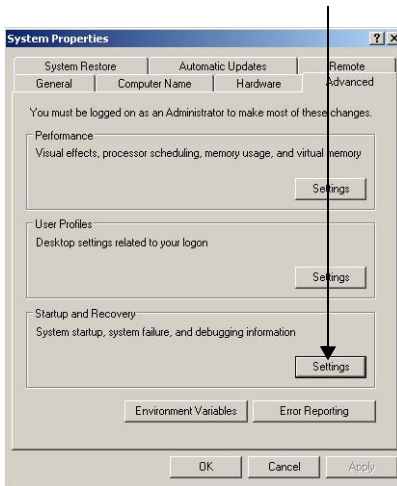

4. Click Edit.

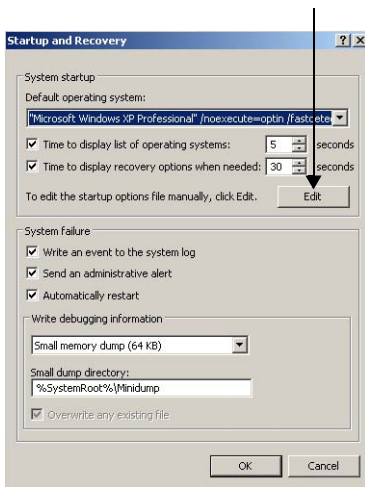

The *boot.ini* file opens in Notepad.

5. Copy the operating systems line and paste it on the next line. E.g.,
`multi (0) disk (0) rdisk (0) partition (1) /WINDOWS="Microsoft Windows XP Professional" /noexecute=optin /fastdetect`
6. Make the following changes to the first line of text:
 - Modify the name of the operating system to “Microsoft Windows XP Professional 3GB”.
 - Add “/3GB”.

- Add “/userva=2432”.

E.g., multi(0)disk(0)rdisk(0)partition(1) /WINDOWS="Microsoft Windows XP Professional 3GB" /noexecute=optin /fastdetect /3GB /userva=2432

7. Save the file and restart your computer.

The /3GB switch should now be the default configuration.

Adding 1GB RAM to the IBM 6223

The minimum requirement for running Lustre 2009 Service Pack 7 on the IBM IntelliStation Z Pro 6223 is 4 GB of RAM. Currently, users have 1GB in DIMM 1 and DIMM 2 and 512MB in DIMM 3 and DIMM 4. The memory needs to be installed in pairs.

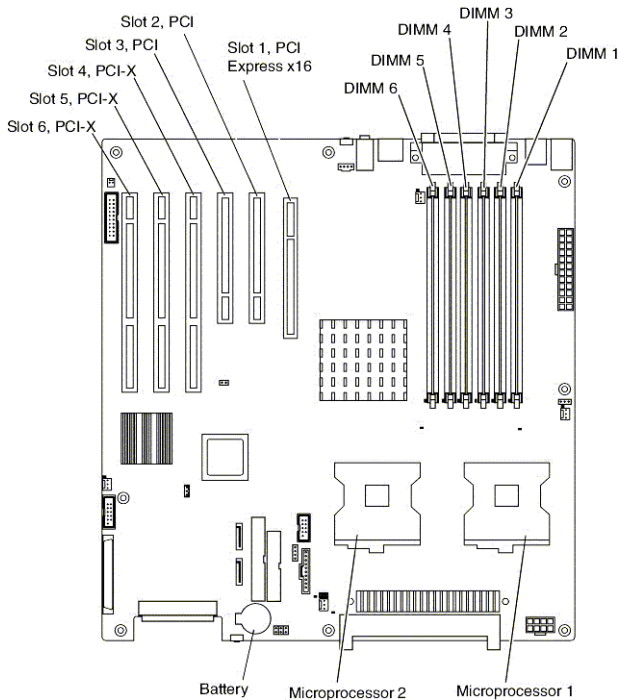

To make sure your system has 4GB, complete one of the following:

- Purchase and install two 512MB DDR2 SDRAM DIMM.
- Purchase and install two 1GB DDR2 SDRAM DIMM.

NOTE: Make sure you do not exceed 4GB of RAM.

To install two 512MB of RAM:

1. Insert the two 512MB DDR2 SDRAM DIMM into DIMM 5 and DIMM 6.
You now have 4GB of RAM.
2. Restart your system for the change to take effect.

To install two 1GB of RAM:

1. Remove the two 512MB DDR2 SDRAM DIMM from DIMM 3 and DIMM 4.
2. Insert the two 1GB DDR2 SDRAM DIMM into DIMM 3 and DIMM 4.
You now have 4GB of RAM.
3. Restart your system for the change to take effect.

***dlConfigCheck* Utility**

The *dlConfigCheck* utility is used to provide you with a list of your workstation configuration (e.g., driver versions, hardware configurations, DKU version, system configurations, etc.). From this list you can quickly determine if your workstation is set up correctly.

NOTE: This procedure applies to the Linux platform only.

To use the *dlConfigCheck* utility:

1. As root, open a terminal.
2. Type:

```
dlConfigCheck
```

The *dlConfigCheck* utility starts and a list of your workstation configuration is displayed.

Obtaining the Host ID of the Linux Workstation

The following procedure has been updated and should be followed if you are referring to “Obtaining the *lmhostid* of the Workstation” in the “Installing Lustre on the Linux Workstation” chapter of the *Software Installation Guide for Linux Workstations*.

NOTE: This procedure applies to the Linux platform only.

To obtain the *lmhostid*:

1. Log in to the workstation.
2. Navigate to the Lustre directory. Type:

```
cd /usr/autodesk/lustre_<version>
```

3. Run the *lmhostid* utility to display a unique *lmhostid* for the machine. Type:

```
./lmhostid
```

A message appears that include a line indicating the *lmhostid* of the machine.

```
The FLEXlm host ID of this machine is "<lmhostid>"
```

For example, in the following line the *lmhostid* is 0017a49978f1.

```
The FLEXlm host ID of this machine is "0017a49978f1"
```

4. Take note of the *lmhostid*.
5. Repeat this procedure for each Linux workstation on which you install Lustre.

Obtaining the *dlhostid*

If you are installing Lustre on an HP xw8600 Linux workstation that has a Visual Effects and Finishing application installed, you need to provide the *dlhostid* in order to request a license code.

NOTE: This procedure applies to the Linux platform only.

To request the host ID:

1. On your workstation, log in using the account for your application, and open a terminal.
2. Run the Discreet host ID utility to display the unique *dlhostid* for the machine. Type:

```
dlhostid
```

A message similar to the following one appears, containing the host ID:

```
dlhostid - Copyright ©2005 by Autodesk, Inc./Autodesk Canada  
Co. All rights reserved.
```

```
The lmhost ID of this machine is "00110910DA2E"
```

```
The Discreet host ID of this machine is  
"DLHOST01=25231AEF83AD9D5E9B2FA270DF4F20B1"
```

3. Send the Discreet host ID to the Licensing Department to receive your application license code. When you record the Discreet host ID, make sure you include the DLHOST01=string as well as the number; for example,

```
DLHOST01=25231AEF83AD9D5E9B2FA270DF4F20B1
```

NOTE: Make sure you obtain a host ID for each workstation on which you install the application.

Storage Configuration

In order to address certain performance issues, the storage Writeback Cache value needs to be changed for each array. This is a manual operation using the Stone Storage Manager (SSM). This change is non-destructive and will not affect the data contained on the disk arrays.



WARNING: The storage configuration modification needs to be completed on all Lustre 2009 workstations.

NOTE: This procedure applies to both the Linux and Windows platforms.

To change the Writeback Cache value for the storage:

1. Connect to the Stone Storage Manager (SSM).
2. In the SSM, click on the first array listed in the Arrays section.
3. In the Array panel, confirm the following settings in the Cache Parameters:

Setting:	Value:
Read-Ahead Cache	Automatic
Writeback Cache	256 MB
Mirror cache (Disable Writeback cache when partner controller is missing or failed.	Disabled
Disable Writeback cache if a controller battery is low, missing, or failed.	Enabled
Disable Writeback cache if array becomes critical (N/A for RAID O).	Enabled
Disable cache Writethrough operation when write cache is full.	Enabled

4. Click Apply.
5. Click Close.
6. Release steps #3-5 for the remaining arrays.
7. Click Close.

Standard VTR and VTR Emulation Control Cable

The following diagram depicts the RS-422 control cable pinouts for the standard VTR control cable.

NOTE: This section applies to both the Linux and Windows platforms.

VTR Control Cable

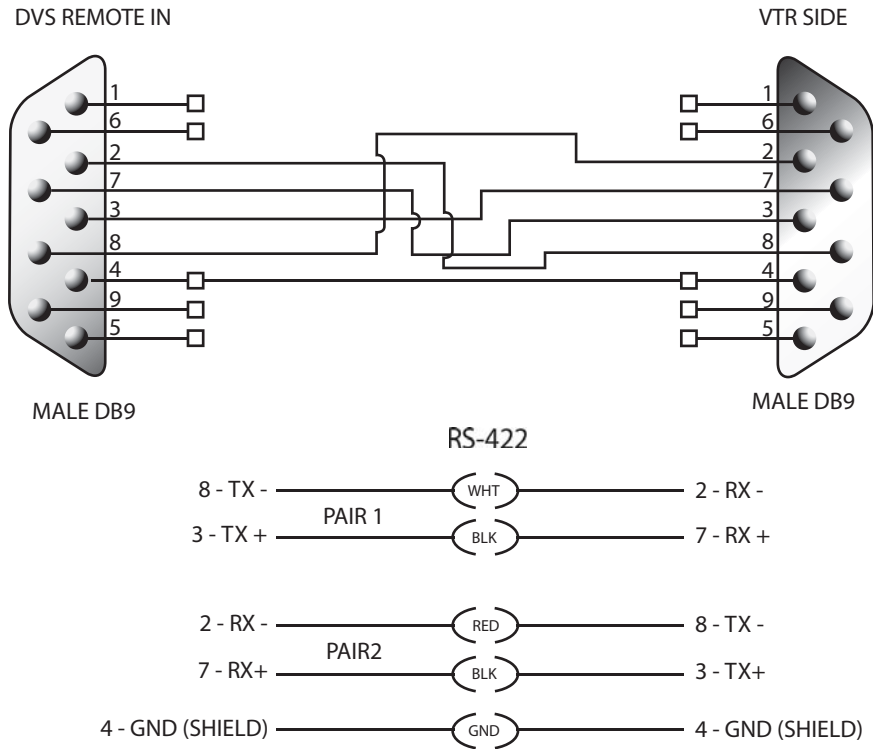

For the emulator mode, you need to use a straight (pin-to-pin) cable as shown in the following diagram.

VTR Control Cable: DVS Controlling VTR (Normal Video I/O Control Cable)

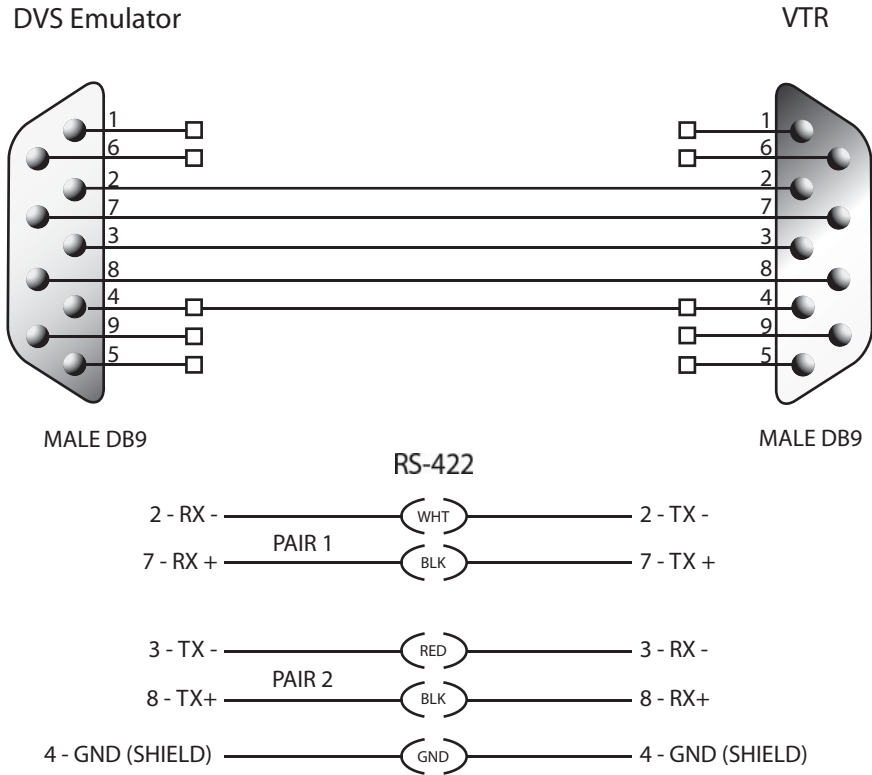

Audio Input and Output

Lustre 2009 introduces new ways to work with audio as well as new audio hardware. A Lucid converter can be used with the new AJA Breakout Box or DVS Centaurus® Breakout Box. For more information about the audio hardware and connection, refer to your *Lustre Hardware Setup Guide*.

Autodesk Control Surface Panel

The home folder contains some control panel files that you can use. These following files are:

- **cp100_default.rules** — Factory default panel file for the CP-100.
- **acs_default.rules** — Factory default panel file for the Autodesk Control Surface (ACS).
- **acs_video.rules** — This file has more sensitive controls for the ACS.

There are a few different ways which you can use these files, but the most common are as follows:

- Modifying the *acs.rules* or *cp100.rules* file within your user folder to your preference. See [“Modifying the User Rules File”](#) on page 18.
- Modifying the default *acs.rules* or *cp100.rules* file within the home folder. See [“Modifying the Default Rules File”](#) on page 18.

Modifying the User Rules File

When you create a new user configuration within the Lustre application, a copy of the *acs.rules* or *cp100.rules* file is copied into your user folder. You can edit this file so your control panel settings are to your preference.

Modifying the Default Rules File

It is possible for you to modify the default *acs.rules* or *cp100.rules* file if you are not pleased with the settings that the current default file provides. To modify the rules file so the modified default settings are used for every new user configuration which is created, modify the *acs.rules* or *cp100.rules* file within the home folder.

Configuration Files

In Lustre 2009, the configuration files are very different from previous versions. Please pay close attention to the *init.config* file.

This file is now used to set the system level settings, like the following:

- Wiretap server auto detection
- Wiretap server IP address
- BrowseD configuration
- System level keywords

The following configuration files are now part of the *init.config* file:

- *wt.config*
- *filmtypes.config*

- *browsed.config*

The location of project and user settings has also changed. Their new locations are:

- *C:/Autodesk/Projects* (Windows)
- *C:/Autodesk/Users* (Windows)
- *usr/autodesk/projects* (Linux)
- *usr/autodesk/users* (Linux)

***init.config* File**



WARNING: When updating to Lustre 2009 Service Pack 7 on the Linux workstation, you need to back up the *init.config* file before updating.

NOTE: This section applies to both the Linux and Windows platforms.

The following updates have been made to the *init.config* file.

Parameter	Data type	Default	Function
<Browsed>			
<Port>	Integer	1055	All computers on the BrowseD network must use the same port to communicate. Use the default value for Windows and Linux over IB. For Linux over IP, set the value to 1044.
<Miscellaneous>			
<ChangeCutOffset>	State	On	Allows the change cut or match grade feature to preserve the keyframe animations based on the record timecode whenever a shot has been replaced or moved within a timeline. NOTE: Be sure to enabled only the Record button within the Match Option when performing a change cut or match grade.

Upgrade Compatibility

You can use project content, like grades, cuts, presets, and so on, created in Lustre 2008/2007 in Lustre 2009 Service Pack 7, but you should always copy the material from the previous release to a new project of Lustre 2009 Service Pack 7.

For instructions on carrying forward project data for Lustre on a Linux workstation, see [“Lustre on a Linux Workstation”](#) on page 27.

Wiretap Interoperability

Lustre 2009 Service Pack 7 is read/write compatible with Wiretap 2008, 2009, and 2009 Extension 1. Lustre 2009 Service Pack 7 can only read and write media to a project that is the same version as the Wiretap server.

The following is a table of Lustre 2009 read and write capabilities if Wiretap server 2009 Extension 1 is running.

Lustre 2009 read / write capability	Version of Visual Effects and Finishing project
Read and write	Visual Effects and Finishing 2009 Extension 1 projects
Read only	Visual Effects and Finishing 2007/2008/2009 projects

SDP over Infiniband Support

To be able to have a high speed IB connection, you need to install the latest Windows IB driver on the Lustre workstation and the latest Linux IB driver on the Visual Effects and Finishing workstation. You will need the following:

- Lustre 2008 Service Pack 2 or higher
- Autodesk® Smoke® or Autodesk® Flame® 2008 Service Pack 4 or higher (with DKU version 3.5.0)

NOTE: For details on how to acquire the correct drivers, firmware, and utilities and how to upgrade your switch firmware, contact your local Autodesk support office. See [“Contacting Customer Support”](#) on page 4.

Lustre 2009 Service Pack 7 supports a socket direct protocol (SDP) over IB connection in addition to the continued support of the IP over IB connection. The performance advantage of the SDP over IB solution is the ability to transfer up to 2K 10-bit source footage in real-time over Wiretap.

For SDP over IB support, the Visual Effects and Finishing application your Lustre workstation connects to must be either Smoke or Flame 2008 Service Pack 4 or 2009 with the latest DKU (the latest DKU has the new IB driver). For full details about Smoke or Flame requirements, see the Release Notes for Smoke or Flame 2008 Service Pack 4 or higher.

NOTE: If using an SDP over IB connection and you choose to manually configure specific Wiretap servers in the *init.config* file, make sure you input the Gigabit Ethernet IP addresses of the Wiretap host machines and not the Infiniband IP addresses.



Installation Documentation Workflows

Summary

Overview	23
Reinstalling from Scratch	23
Connecting New or Expanded Stone Direct Storage	24
Upgrading Lustre	25
Documentation FAQs	25

Overview

Your Autodesk Lustre 2009 system is shipped preconfigured with the appropriate operating system and application already installed. In normal situations, the final configuration procedures are simple and well documented.

This chapter highlights four common installation workflows that you may need to perform, and lists the documentation relevant to each. You should always identify and gather the relevant documentation before proceeding with any installation workflow.

Reinstalling from Scratch

Follow this workflow when you need to completely rebuild your Lustre system: from cross-connecting the hardware peripherals and storage arrays, to installing the operating system, and installing, licensing, and configuring your application.

To reinstall your system from scratch:

1. Prepare for the installation.
Consult the *Autodesk Lustre 2009 Service Pack 7 Release Notes* (web version) for the latest requirements and late-breaking information.
2. Connect the hardware peripherals to the workstation.
Consult the *Hardware Setup Guide* for your workstation.

3. Connect your storage.
Consult the *Autodesk Stone Direct Configuration Guide* for your release.
4. Install the operating system.
For Windows workstations, consult the *Autodesk Lustre 2009 Software Installation Guide for Windows Workstations*.

For Linux workstations, consult the *Autodesk Lustre 2009 Software Installation Guide for Linux Workstations* or *Autodesk Incinerator 2009 Installation and User Guide*.
5. Configure the RAID volumes and mount the storage.
Consult the *Autodesk Stone Direct Configuration Guide* for your release.
6. Install and license Lustre.
Consult the *Autodesk Lustre 2009 Software Installation Guide for Windows Workstations* for Windows workstations.

For Linux workstations, consult the *Autodesk Lustre 2009 Software Installation Guide for Linux Workstations* or *Autodesk Incinerator 2009 Installation and User Guide*.
7. Get going.
Read the *Autodesk Lustre 2009 User Guide* and *Autodesk Lustre 2009 New Features Guide* to get familiar with Lustre's powerful features.

Connecting New or Expanded Stone Direct Storage

Follow this workflow when you need to rebuild your Autodesk workstation's Stone Direct storage array. For instance, this may be required when you purchase supplementary storage enclosures to expand available disk space.

To connect new or expanded Stone Direct storage:

1. Prepare for the installation.
Consult the *Autodesk Lustre 2009 Service Pack 7 Release Notes* (web version) for the latest requirements and late-breaking information.
2. Connect your storage.
Consult the *Autodesk Stone Direct Configuration Guide* for your release.
3. Configure the RAID volumes and mount the storage.
Consult the *Autodesk Stone Direct Configuration Guide* for your release.
4. Configure your filesystem.
Consult the *Autodesk Lustre 2009 Software Installation Guide* for your operating system.

5. Begin working with Lustre.

Read the *Autodesk Lustre 2009 User Guide* and *Autodesk Lustre 2009 New Features Guide* to get familiar with your application's powerful features.

Upgrading Lustre

Follow this workflow in cases where you need to install or upgrade your application. Typically, you do not have to reformat the filesystem or upgrade the operating system when you upgrade the application.

To upgrade your application:

1. Prepare for the installation.

Consult the *Autodesk Lustre 2009 Service Pack 7 Release Notes* (web version) for the latest requirements and late-breaking information.

2. Install and license your application.

Consult the *Autodesk Lustre 2009 Software Installation Guide* for your operating system.

3. Begin working with Lustre.

Read the *Autodesk Lustre 2009 User Guide* and *Autodesk Lustre 2009 New Features Guide* to get familiar with your application's powerful features.

Documentation FAQs

Here are a few examples of common installation enquiries, and the documentation that provides the answers to each.

How Do I Request a License for Lustre?

Consult the *Autodesk Lustre 2009 Software Installation Guide* for your operating system for installation procedures and information on obtaining and installing the licenses required to launch your application.

How Do I Learn About the Latest Updates?

Consult the *Autodesk Lustre 2009 Service Pack 7 Release Notes* (web version). They contain the most current information about requirements and procedures.

How Do I Find Out About All the New Features for This Release?

Read the *Autodesk Lustre 2009 New Features Guide* for an overview of new features. For complete new feature information, consult the *Autodesk Lustre 2009 User Guide*.

Summary

Overview	27
Features No Longer Used in Lustre	27
Limitations for Lustre 2009	27
Lustre on a Linux Workstation	27
Telecine-mode Playout	28
Wiretap	29

Overview

This chapter contains a collection of late additions to the *Lustre 2009 User Guide*.

Features No Longer Used in Lustre

The DDR Chase feature is no longer available on systems with DVS, and the automatic pulldown detection feature is no longer available on systems with DVS.

Limitations for Lustre 2009

The Timeline Sort mode and Collapse view are not available when you are working in Stereoscopy mode.

Lustre on a Linux Workstation

When you are installing the Lustre 2009 software on Linux, a Lustre user is created. Since project data was created as Root in previous Lustre releases, you have to change the file permission for all your project folders in order to use them with Lustre 2009.

To use your previous project data with Lustre 2009:

1. Log in as root.
2. Install Lustre 2009.
3. Log in as Lustre user (you will see a Lustre 2009 icon on the login page)

NOTE: A password is not needed to log in.

4. Start Lustre by clicking the Lustre icon or by typing Lustre in a shell.
5. Navigate to your project folders.
6. As root, type in the shell:

```
chmod 777 *
```

The project files and folders can now be read/written using Lustre 2009. Repeat steps 5 and 6 for your scans and render folders.

Telecine-mode Playout

The Telecine-mode playout is now available on both the DVS and AJA systems. You can only create a Telecine tape in Assemble mode (Insert and Record mode are not available). You can perform a Telecine-mode Playout from the Print view (P) or the Output view (O) if you enable the Playout From Timeline option. In Lustre 2009 you will not use the LTC Out from the DVS to feed the timecode to the VTR; instead you will use the RS-422.

NOTE: Since it is not possible to playout, with the Telecine-mode, shots with retime effects, you need to use the timeline sort mode feature before performing the playout. This will output the graded source media without the retime effect.

To perform a Telecine-mode Playout:

1. Set the VTR Timecode Generator to Internal / Preset.
2. Do one of the following:
 - If you are using a Digital Betacam, set the VTR menu Regen Mode (610) to Manual.
 - If you are using an HDCam or HD-D5, the Regen mode is set to Automatic by default. You do not need to change anything.
3. Grade your timeline.
4. Use the Editing > Assemble > Timeline Sort Mode tool to sort your timeline in C-mode (with or without heads and tails).

5. If you intend to use the Print view for playout, render the media, but if you intend to use the Output view, enable the Playout From Timeline.

NOTE: You can also use the RealTime Deliverables view (D).

6. In the Editing > Playout menu, enable Telecine-mode.
7. Set the duration of the Black media that is added before each shot (default is five seconds).
8. Set the Start Timecode.
9. Press Assemble.

Wiretap

The following are the updates to Wiretap and the Wiretap workflow.

Wiretap Command Line Tools

The Wiretap command line tools are available in the tools folder of the Lustre application.

For more information about the command line tools, refer to the *Autodesk Wiretap SDK Developer Guide*.

Timewarp from Smoke or Flame

There is an optimization of the timewarp processing in Smoke and Flame that causes problems with Lustre. When processing a timewarp speed that does repeat the same media (e.g., 0%, 50%, etc.) the same media is repeated. This makes the timewarp processing faster, but shows the timewarped shots as single frame edit result in Lustre. To disable the timewarp processing option, type the following environment variable before launching Smoke or Flame:

```
setenv DL_DISABLE_NOOP_SOFT_FX_OPTIMISATION
```

The default state of the variable is OFF, meaning that by default the optimization is enabled in Smoke and Flame, and Lustre will be given a single-frame edit for any timewarp shot. If there is a problem when you are loading a timeline in Lustre, you need to exit Smoke or Flame, set the environment variable as shown above, and process in Smoke or Flame. Next, reload the timeline in Lustre.

NOTE: This is only available with Smoke and Flame 2009 Extension 1.

Publish

When working with Smoke or Flame over Wiretap, it is possible to use published content. If you intend to generate local proxies for Wiretap content, make sure the Publish operation in Smoke or Flame is performed with the following options:

- Select the Flatten Publish option.
- Set the Type option to Media+EDL.
- Set the Output Format to DPX.
- Set the File Naming option to Use Clip Timecode.
- Set the Head/Tail option.
- Select the Create Sub Directories option.
- Set the Destination path to a shared storage (e.g., NAS or SAN).
- Enable the Link option if the source media is located on the same destination file system.

This will avoid duplication of media.

Once all the options have been set, click Publish.

File Naming is a new option in Smoke and Flame 2009 Extension 1. It allows you to define how the file name of the published media is created.

- <timeline name>_<shot name>_<frame>.dpx (use clip name)
- <source timecode>.dpx (use clip timecode)
- <timeline name>_<shot name>_<source timecode>.dpx (use both)

Since Lustre uses the filename to generate the local proxy, you have to select the Use Clip Timecode option. With this option, the proxy media will always be referenced by Lustre even if the structure of the timeline changes. The Use Clip Name option changes the shot name based on the timeline position of the shot (e.g., shot1, shot2, etc.)