

**Autodesk®**  
Incinerator® 2009

# Installation and User Guide

© 2008 Autodesk, Inc. All rights reserved. Except as otherwise permitted by Autodesk, Inc., this publication, or parts thereof, may not be reproduced in any form, by any method, for any purpose.

Certain materials included in this publication are reprinted with the permission of the copyright holder.

Portions relating to ADOdb Copyright © 2000, 2001, 2002, 2003, 2004 John Lim. All rights reserved. Redistribution and use in source and binary forms, with or without modification, are permitted provided that the following conditions are met: Redistributions of source code must retain the above copyright notice, this list of conditions and the following disclaimer. Redistributions in binary form must reproduce the above copyright notice, this list of conditions and the following disclaimer in the documentation and/or other materials provided with the distribution. Neither the name of the John Lim nor the names of its contributors may be used to endorse or promote products derived from this software without specific prior written permission. **DISCLAIMER: THIS SOFTWARE IS PROVIDED BY THE COPYRIGHT HOLDERS AND CONTRIBUTORS "AS IS" AND ANY EXPRESS OR IMPLIED WARRANTIES, INCLUDING, BUT NOT LIMITED TO, THE IMPLIED WARRANTIES OF MERCHANTABILITY AND FITNESS FOR A PARTICULAR PURPOSE ARE DISCLAIMED. IN NO EVENT SHALL JOHN LIM OR CONTRIBUTORS BE LIABLE FOR ANY DIRECT, INDIRECT, INCIDENTAL, SPECIAL, EXEMPLARY, OR CONSEQUENTIAL DAMAGES (INCLUDING, BUT NOT LIMITED TO, PROCUREMENT OF SUBSTITUTE GOODS OR SERVICES; LOSS OF USE, DATA, OR PROFITS; OR BUSINESS INTERRUPTION HOWEVER CAUSED AND ON ANY THEORY OF LIABILITY, WHETHER IN CONTRACT, STRICT LIABILITY, OR TORT (INCLUDING NEGLIGENCE OR OTHERWISE) ARISING IN ANY WAY OUT OF THE USE OF THIS SOFTWARE, EVEN IF ADVISED OF THE POSSIBILITY OF SUCH DAMAGE.**

Portions relating to GetOpt Copyright © 1987, 1993, 1994. The Regents of the University of California. All rights reserved. Redistribution and use in source and binary forms, with or without modification, are permitted provided that the following conditions are met: 1. Redistributions of source code must retain the above copyright notice, this list of conditions and the following disclaimer. 2. Redistributions in binary form must reproduce the above copyright notice, this list of conditions and the following disclaimer in the documentation and/or other materials provided with the distribution. 3. All advertising materials mentioning features or use of this software must display the following acknowledgement: This product includes software developed by the University of California, Berkeley and its contributors. 4. Neither the name of the University nor the names of its contributors may be used to endorse or promote products derived from this software without specific prior written permission. **THIS SOFTWARE IS PROVIDED BY THE REGENTS AND CONTRIBUTORS "AS IS" AND ANY EXPRESS OR IMPLIED WARRANTIES, INCLUDING, BUT NOT LIMITED TO, THE IMPLIED WARRANTIES OF MERCHANTABILITY AND FITNESS FOR A PARTICULAR PURPOSE ARE DISCLAIMED. IN NO EVENT SHALL THE REGENTS OR CONTRIBUTORS BE LIABLE FOR ANY DIRECT, INDIRECT, INCIDENTAL, SPECIAL, EXEMPLARY, OR CONSEQUENTIAL DAMAGES (INCLUDING, BUT NOT LIMITED TO, PROCUREMENT OF SUBSTITUTE GOODS OR SERVICES; LOSS OF USE, DATA, OR PROFITS; OR BUSINESS INTERRUPTION) HOWEVER CAUSED AND ON ANY THEORY OF LIABILITY, WHETHER IN CONTRACT, STRICT LIABILITY, OR TORT (INCLUDING NEGLIGENCE OR OTHERWISE) ARISING IN ANY WAY OUT OF THE USE OF THIS SOFTWARE, EVEN IF ADVISED OF THE POSSIBILITY OF SUCH DAMAGE.**

Portions relating to GetOpt Copyright © 1999, 2000 Politecnico di Torino. All rights reserved. Redistribution and use in source and binary forms, with or without modification, are permitted provided that: (1) source code distributions retain the above copyright notice and this paragraph in its entirety; (2) distributions including binary code include the above copyright notice and this paragraph in its entirety in the documentation or other materials provided with the distribution, and (3) all advertising materials mentioning features or use of this software display the following acknowledgement: "This product includes software developed by the Politecnico di Torino, and its contributors." Neither the name of the University nor the names of its contributors may be used to endorse or promote products derived from this software without specific prior written permission. **THIS SOFTWARE IS PROVIDED "AS IS" AND WITHOUT ANY EXPRESS OR IMPLIED WARRANTIES, INCLUDING, WITHOUT LIMITATION, THE IMPLIED WARRANTIES OF MERCHANTABILITY AND FITNESS FOR A PARTICULAR PURPOSE.**

Portions relating to LibXML2 2.6.20 Copyright © 2005 Daniel Veillard. Permission is hereby granted, free of charge, to any person obtaining a copy of this software and associated documentation files (the "Software"), to deal in the Software without restriction, including without limitation the rights to use, copy, modify, merge, publish, distribute, sublicense, and/or sell copies of the Software, and to permit persons to whom the Software is furnished to do so, subject to the following conditions: The above copyright notice and this permission notice shall be included in all copies or substantial portions of the Software. **THE SOFTWARE IS PROVIDED "AS IS", WITHOUT WARRANTY OF ANY KIND, EXPRESS OR IMPLIED, INCLUDING BUT NOT LIMITED TO THE WARRANTIES OF MERCHANTABILITY, FITNESS FOR A PARTICULAR PURPOSE AND NONINFRINGEMENT. IN NO EVENT SHALL THE AUTHORS OR COPYRIGHT HOLDERS BE LIABLE FOR ANY CLAIM, DAMAGES OR OTHER LIABILITY, WHETHER IN AN ACTION OF CONTRACT, TORT OR OTHERWISE, ARISING FROM, OUT OF OR IN CONNECTION WITH THE SOFTWARE OR THE USE OR OTHER DEALINGS IN THE SOFTWARE.**

The following are registered trademarks or trademarks of Autodesk, Inc., in the USA and other countries: 3DEC (design/logo), 3December, 3December.com, 3ds Max, ADI, Alias, Alias (swirl design/logo), AliasStudio, Alias|Wavefront (design/logo), ATC, AUGI, AutoCAD, AutoCAD Learning Assistance, AutoCAD LT, AutoCAD Simulator, AutoCAD SQL Extension, AutoCAD SQL Interface, Autodesk, Autodesk Envision, Autodesk Insight, Autodesk Intent, Autodesk Inventor, Autodesk MapGuide, Autodesk Streamline, AutoLISP, AutoSnap, AutoSketch, AutoTrack, Backdraft, Built with ObjectARX (logo), Burn, Buzzsaw, CAiCE, Can You Imagine, Character Studio, Cinestream, Civil 3D, Cleaner, Cleaner Central, BackScale, Colour Warper, Combustion, Communication Specification, Constructware, Content Explorer, Create>what's>Next> (design/logo), Dancing Baby (image), DesignCenter, Design Doctor, Designer's Toolkit, DesignKids, DesignProf, DesignServer, DesignStudio, Design[Studio] (design/logo), Design Web Format, DWF, DWG, DWG (logo), DWG Extreme, DWG TrueConvert, DWG TrueView, DXF, Ecotect, Exposure, Extending the Design Team, FBX, Filmbox, FMDesktop, Freewheel, GDX Driver, Gmax, Green Building Studio, Heads-up Design, Heidi, HumanIK, IDEA Server, i-drop, ImageModeler, iMOUT, Incinerator, Inventor, Inventor LT, Kaydara, Kaydara (design/logo), Kynapse, Kynogon, LocationLogic, Lustre, Matchmover, Maya, Mechanical Desktop, MotionBuilder, Movimento, Mudbox, NavisWorks, ObjectARX, ObjectDBX, Open Reality, Opticore, Opticore Opus, PolarSnap, PortfolioWall, Powered with Autodesk Technology, Productstream, ProjectPoint, ProMaterials, RasterDWG, Reactor, RealDWG, Real-time Roto, REALVIZ, Recognize, Render Queue, Retimer, Reveal, Revit, Showcase, ShowMotion, SketchBook, SteeringWheels, Stitcher, StudioTools, Topobase, Toxik, TrustedDWG, ViewCube, Visual, Visual Construction, Visual Drainage, Visual Landscape, Visual Survey, Visual Toolbox, Visual LISP, Voice Reality, Volo, Vtour, Wiretap, and WiretapCentral.

The following are registered trademarks or trademarks of Autodesk Canada Co. in the USA and/or Canada and other countries: Backburner, Discreet, Fire, Flame, Flint, Frost, Inferno, Multi-Master Editing, River, Smoke, Sparks, Stone, and Wire.

The following are registered trademarks or trademarks of Moldflow Corp. in the USA and/or other countries: Moldflow MPA, MPA (design/logo), Moldflow Plastics Advisers, MPI, MPI (design/logo), Moldflow Plastics Insight, MPX, MPX (design/logo), Moldflow Plastics Xpert.

All other brand names, product names or trademarks belong to their respective holders.

## **Disclaimer**

THIS PUBLICATION AND THE INFORMATION CONTAINED HEREIN IS MADE AVAILABLE BY AUTODESK, INC. "AS IS." AUTODESK, INC. DISCLAIMS ALL WARRANTIES, EITHER EXPRESS OR IMPLIED, INCLUDING BUT NOT LIMITED TO ANY IMPLIED WARRANTIES OF MERCHANTABILITY OR FITNESS FOR A PARTICULAR PURPOSE REGARDING THESE MATERIALS.

Title: Autodesk Incinerator 2009 Installation and User Guide

Document Version: 2

Date: October 19, 2008



# contents

## Contents

---

<b>1</b>	<b>Introduction</b>	<b>1</b>
	Summary .....	1
	About Autodesk Incinerator .....	1
	About this Guide .....	1
	Related Documentation .....	2
	Notational Conventions .....	4
	Contacting Customer Support .....	4
<b>2</b>	<b>Installation Overview and Workflow</b>	<b>7</b>
	Summary .....	7
	Incinerator System Overview .....	7
	Required Installation Media .....	10
<b>3</b>	<b>Connecting Components and Peripherals</b>	<b>11</b>
	Summary .....	11
	Workflow for Connecting Components and Peripherals .....	11
	Verifying the Hardware Shipment .....	12
	Verifying the Hardware Environment .....	12
	Installing Rack-Mount Hardware Components .....	15
	Connecting Nodes and the Media Server to the Incinerator Network .....	17
	Connecting Workstations .....	21
	Connecting a Keyboard, Monitor, and Mouse to the KVM Switch .....	21
	Verifying BIOS Versions and Settings .....	22

<b>4</b>	<b>Installing the Linux Operating System</b>	<b>29</b>
	Summary .....	29
	Choosing an Install Process.....	29
	Installing Linux Using a Centralized Install Process.....	30
	Installing Linux Using a Local Install Process .....	32
	Customizing Network Settings .....	33
<b>5</b>	<b>Configuring Storage</b>	<b>37</b>
	Summary .....	37
	Workflow for Configuring Storage .....	37
	Connecting and Powering Up Storage .....	38
	Creating Hardware LUNs .....	38
	LUNs and Partitions.....	39
	Assembling the LUNs into a Logical Volume .....	43
	Creating the XFS Filesystem on the Storage Array .....	46
<b>6</b>	<b>Installing Incinerator Software</b>	<b>49</b>
	Summary .....	49
	Workflow for Installing Incinerator Software .....	49
	Copying the Application Software onto the Lustre Media Server .....	49
	Installing the Lustre Media Server Software.....	50
	Installing the Incinerator Node Software .....	51
	Installing the Workstation Software .....	51
<b>7</b>	<b>Licensing and Starting Incinerator</b>	<b>53</b>
	Summary .....	53
	Workflow for Licensing, Configuring, and Using Incinerator .....	53
	Determining the License Codes You Require .....	54
	Obtaining the lmhostids .....	54
	Requesting Incinerator License Codes .....	55
	Installing the License Server .....	56
	Creating the License File for the License Server .....	56
	Starting the License Server.....	57
	Installing the BrowseD License on the Lustre Media Server .....	58
	Installing Incinerator Node Licenses.....	58
	Installing the Workstation License .....	59
	Configuring Incinerator Daemons.....	60

	Using Lustre with Incinerator.....	62
<b>8</b>	<b>Using the Incinerator Resource Manager</b>	<b>67</b>
	Summary .....	67
	About the Incinerator Resource Manager .....	67
	Starting the Resource Manager.....	68
	Monitoring the Status of System Components .....	70
	Managing Incinerator Node Groups.....	75
	Stopping and Starting Incinerator Daemons .....	86
	Deleting Duplicate Lustre Media Servers, Workstations, and Nodes .....	89
	Managing Resource Manager User Accounts .....	90
<b>9</b>	<b>Troubleshooting Tips</b>	<b>97</b>
	Summary .....	97
	Resolving Common Problems .....	97
	Stopping and Starting Incinerator Daemons Manually .....	101
	Viewing Incinerator Daemon Log Files .....	102
	Changing the IP Addressing Scheme.....	103
	InfiniBand Management .....	105
<b>A</b>	<b>Configuring Background Rendering</b>	<b>109</b>
	Summary .....	109
	Software for Background Rendering.....	109
	Workflow for Setting Up Background Rendering.....	110
	Installing Backburner Manager and Backburner Web Monitor.....	110
	Configuring Lustre to Connect to Backburner Manager .....	111
	Installing and Configuring Burn for Lustre .....	112
	Configuring Backburner Server to Connect to Backburner Manager .....	112
	Starting Backburner Server .....	113
	Licensing Burn for Lustre .....	113
	Specifying the Background Rendering Path in Lustre .....	114
	Using BrowseD for Rendering with Burn for Lustre.....	115

<b>B</b>	<b>Software, Project, and User Configuration Files</b>	<b>117</b>
	Summary .....	117
	Configuration File Overview.....	117
	System Settings .....	118
	<b>Index</b>	<b>123</b>



# Introduction

## Summary

- [About Autodesk Incinerator](#) ..... 1
- [About this Guide](#) ..... 1
- [Related Documentation](#) ..... 2
- [Notational Conventions](#) ..... 4
- [Contacting Customer Support](#) ..... 4

## About Autodesk Incinerator

Autodesk® Incinerator® dramatically increases the power of real-time playback in Autodesk Lustre®, the award-winning high-performance digital intermediate system for HD, 2K and 4K colour grading. Incinerator employs a unique and powerful data transfer architecture that enables “in-line” processing by several computers to allow the colourist to apply multiple selectives and effects while maintaining real-time playback at full native resolution. All of this power frees the colourist to find the perfect colour grade and effect while providing instant results and interactivity to the client during a session.

Incinerator provides the following benefits to colorists, clients, and facilities:

- Colourists benefit because Incinerator allows them to expand their creativity and see the results of their work in real-time.
- Clients benefit because Incinerator allows them to find their exact grade or effect in less time.
- Facilities benefit because Incinerator is a software-based solution built around standard PC hardware and networking components that are easy to integrate and manage.

## About this Guide

This guide describes how to set up, manage, and troubleshoot Incinerator in your facility.

In most cases, hardware integration and software installation are done on delivery by an authorized technician, therefore some of the procedures in this guide may not be necessary.

However, it is a good idea to read through all chapters to familiarize yourself with the configuration procedures for the following reasons:

- If you suspect your Incinerator system is malfunctioning due to loose connections or improperly configured devices, this guide helps you troubleshoot problems by providing information about properly configured systems.
- If you need to call Customer Support, information in this guide is useful because you are in a better position to provide diagnostic information.
- If you want to move your Incinerator system at any time, or upgrade certain hardware components, information in this guide is crucial.

The most up-to-date versions of all guides are available in PDF format from the Web at [www.autodesk.com/lustre-documentation](http://www.autodesk.com/lustre-documentation). For best results viewing and printing these PDF files, use Adobe® Acrobat® Reader™ 7 or later.

## Intended Audience

This guide assumes you have knowledge of Lustre, Linux® system administration, and computer hardware and networking for the PC platform. Do not attempt to carry out the procedures if you are unfamiliar with any of these subjects. Contact Customer Support should you require further assistance. See [“Contacting Customer Support”](#) on page 4.

**NOTE:** Most procedures described in this guide require root or super-user privileges.

## Related Documentation

The following tables list the documentation associated with the current release. For details on each of these documents, as well as for help obtaining them, refer to your release notes.

User and Reference Guides	Provides
<i>Autodesk Lustre 2009 User Guide</i>	Detailed instructions on using Lustre.
<i>Autodesk Lustre 2009 New Features Guide</i>	Information about the new features for this release.
<i>Autodesk Control Surface User Guide</i>	Detailed instructions on using the Autodesk control surface and the Tangent CP 100.
<i>Autodesk Lustre 2009 Hot Keys Card</i>	A list of the most frequently used hot keys.
<i>Autodesk Lustre 2009 Release Notes</i>	A complete list of documentation and information on late-breaking features.
<i>Autodesk Lustre 2009 Fixed and Known Bugs</i>	A complete list of fixed and known bugs for this release.

<b>Installation and Configuration Guides</b>	<b>Provides</b>
<i>Hardware Setup Guide</i> (for your workstation)	Information on how to set up your workstation and video I/O peripherals.
<i>Linux RHEW 4 Update 3 Installation and Configuration Guide</i>	Information on how to install and configure the Linux operating system on your workstation (should you require to do so) .
<i>Stone Direct Configuration Guide</i>	Provides detailed connectivity diagrams and configuration procedures for your Autodesk Stone® storage arrays.
<i>Stone and Wire Filesystem and Networking Guide</i>	Procedures for configuring your Autodesk Wiretap® services.
<i>Autodesk Lustre 2009 Software Installation Guide</i> (for your operating system)	Information about installing and licensing your Autodesk Lustre software.
<i>Autodesk Incinerator 2009 Installation and User Guide</i>	Information on installing, licensing, and using Autodesk® Incinerator®.
<b>Other Guides</b>	<b>Provides</b>
<i>Autodesk Backburner 2008.1 Installation Guide</i> and <i>Autodesk Backburner 2008.1 User Guide</i>	Information on how to install, set up, and use Autodesk Backburner™.
<i>Lustre Sparks API Reference Guide</i>	Instructions for developing Sparks® plug-ins for Lustre.

Consult the Autodesk Web site at [www.autodesk.com/lustre-documentation](http://www.autodesk.com/lustre-documentation) for the latest version of guides, release notes, and fixed and known bugs documents.

## Accessing PDF Documentation

The complete documentation set is available in PDF (Portable Document Format) for online viewing and printing. On Windows® systems, use Adobe® Acrobat® Reader™ to view and print the PDF files. On Linux workstations, use either Adobe Acrobat Reader or the Xpdf viewer. You can access the PDF files from the Incinerator software CD or from [www.autodesk.com/lustre-documentation](http://www.autodesk.com/lustre-documentation).

**NOTE:** If you do not have Acrobat Reader, you can download a free copy from the Adobe Web site ([www.adobe.com](http://www.adobe.com)). If you do not have Xpdf viewer, you can download a free copy from the Xpdf Web site ([www.foolabs.com/xpdf/](http://www.foolabs.com/xpdf/)).

## From the Incinerator Application CD

You can view and print the PDF files from the Incinerator CD using Adobe Acrobat Reader. All PDF files are located in a directory called *Documentation* at the top level of the CD.

**To view the PDF files on the application CD:**

1. Place the Incinerator CD in the CD-ROM drive of your system.
2. If using the Windows version of Incinerator, in Windows Explorer, go to the *Documentation* folder on the CD.
3. If using the Linux version of Incinerator, open a Linux shell and navigate to the *Documentation* folder on the CD. Type:

```
/mnt/cdrom/documentation
```

4. To view one of the documentation PDF files, do one of the following:
  - If using the Windows version of Incinerator, double-click the desired file.
  - If using the Linux version of Incinerator, type:

```
xpdf <filename>
```

The file opens in Acrobat Reader or the Xpdf viewer.

**Accessing PDF Documentation from the Autodesk Web Site**

You can also find the PDF files on the Autodesk Web site, [www.autodesk.com/lustre-documentation](http://www.autodesk.com/lustre-documentation), and download any of the available files.

## Notational Conventions

A number of style conventions are used throughout this guide. These conventions and examples of their use are shown as follows.

Convention	Example
Text that you enter in a command line or shell appears in Courier bold. You must press ENTER after each command.	<b>rpm -qa</b>
Variable names appear in Courier, enclosed in angle brackets. No spaces are allowed in variable names.	<variable_name>
Variables that appear enclosed in square brackets are optional.	[<filename>]
Feedback from the command line or shell appears in Courier.	limit coredumpsize
Directory names, filenames, URLs, and command line utilities appear in italics.	<i>/usr/discreet</i>

## Contacting Customer Support

A list of contact information for Autodesk Media and Entertainment Customer Support is available at [www.autodesk.com/support](http://www.autodesk.com/support).

Customer support is also available through your Autodesk reseller. To find a reseller near you, consult the reseller look-up database on the Autodesk Web site at [www.autodesk.com/resellers](http://www.autodesk.com/resellers).



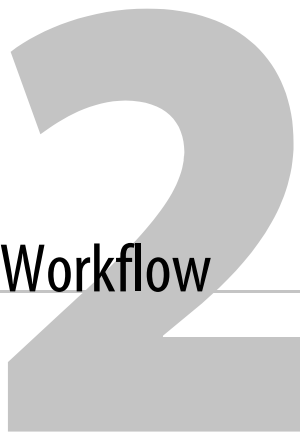

# Installation Overview and Workflow

## Summary

<a href="#">Incinerator System Overview</a> .....	7
<a href="#">Required Installation Media</a> .....	10

## Incinerator System Overview

The core Incinerator system consists of the following components:

**Lustre workstation** — The Lustre workstation is a Linux workstation running either as a Master Station or a Lustre Station. From the Master Station, colorists apply grades and effects to shots and play them back in real-time. The Lustre Station is used to perform tasks that do not require the direct intervention or supervision of the colorist. It is not used to apply effects or play those effects back in real time.

In an Incinerator system no storage is directly attached to the Lustre workstation. All storage is attached to the Lustre Media Server.

**Incinerator Nodes** — The Incinerator Nodes process frames inline so that they can be played back on the workstation.

The Incinerator Nodes receive requests from the workstation to process selected frames. The Incinerator Nodes send requests for those frames to the Lustre Media Server. After the Incinerator Nodes process the frames, they send them back to the workstation for real-time playback.

You can also use the Incinerator Nodes to perform background rendering over the InfiniBand® network using Burn™ for Lustre. For information on setting up background rendering for Lustre, refer to [Appendix A, “Configuring Background Rendering,”](#) on page 109.

**Lustre Media Server** — The Lustre Media Server is the gateway to all the storage devices attached to it. It manages requests for frames and can store other project data.

Communication between these devices is carried over two networks. The private Incinerator Gigabit Ethernet (GigE) network manages control data. The high-speed InfiniBand network handles the transfer of frames to ensure real-time playback.

The following illustration demonstrates how the core components are connected.

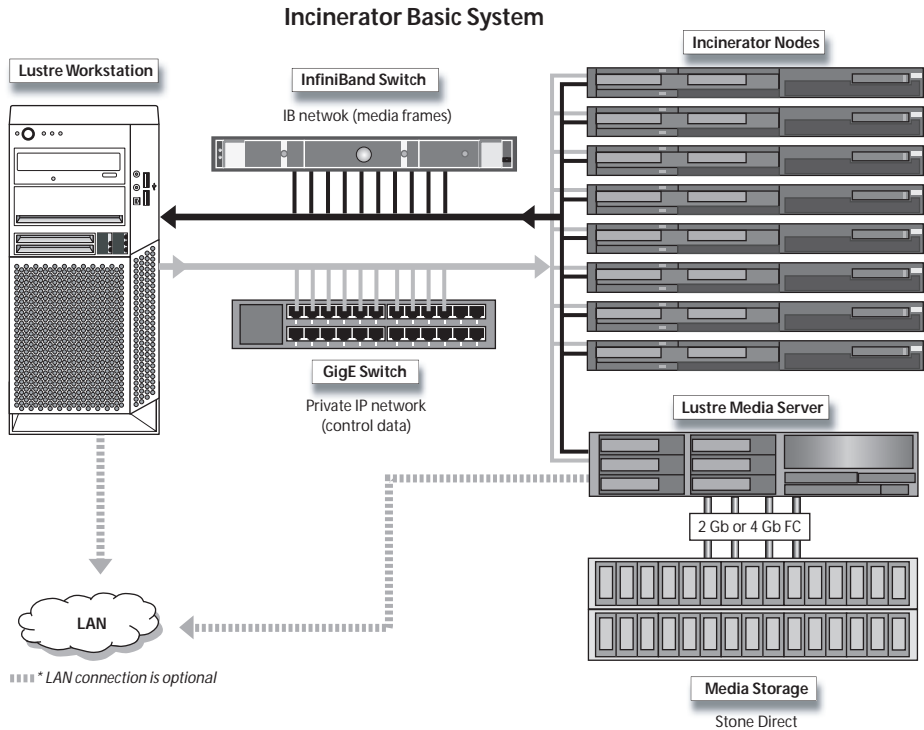

**NOTE:** A 4-loop connection to storage from the Lustre Media Server is illustrated. Both 2-loop and 4-loop connections are supported.

### Expanding Your System

You can expand your system to include additional workstations, Incinerator Nodes, and storage. The following illustration demonstrates how you can expand your system.

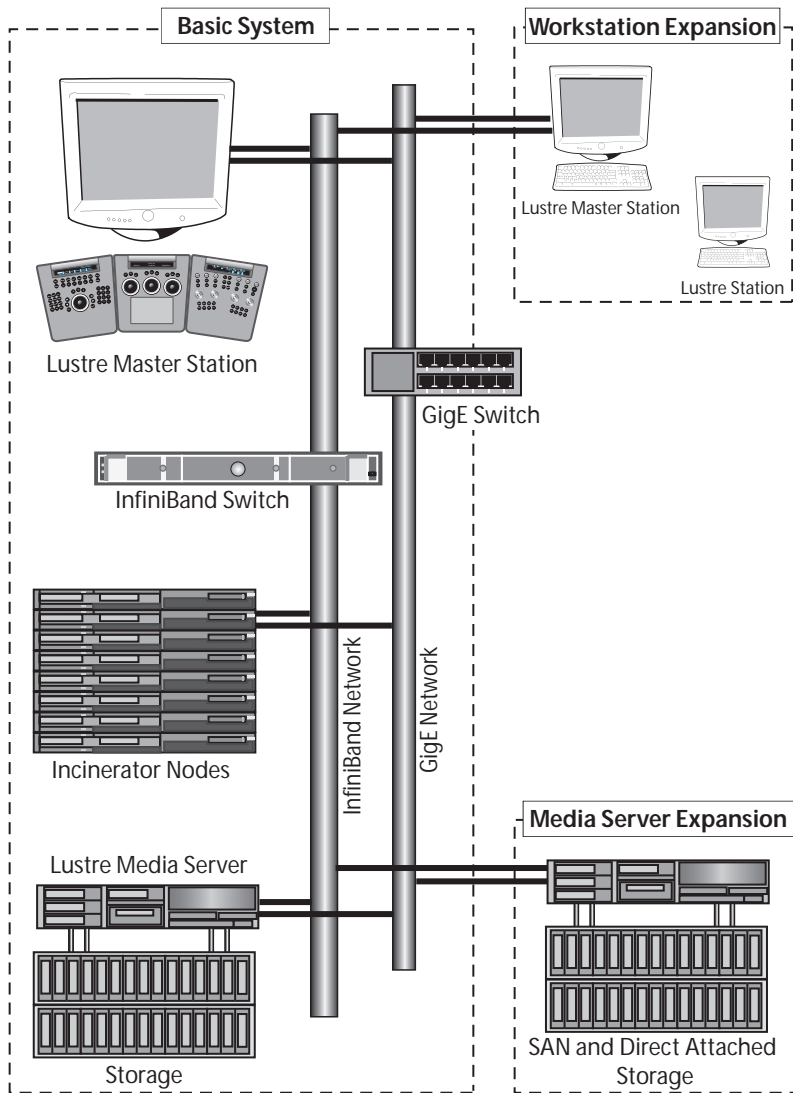

**NOTE:** In a configuration with more than one Lustre Media Server, it is important to understand that Lustre can only connect to a single Lustre Media Server at a time; all read and write paths must point to the same Lustre Media Server. You cannot, for example, simultaneously read from one Lustre Media Server and write to another.

## Connecting an Visual Effects and Finishing Workstation to Your System

You can connect a Visual Effects and Finishing workstation (for example a workstation running Autodesk Flame® 2009 or Autodesk Smoke® 2009) to an Incinerator configuration. The workstation must be on the same Gigabit Ethernet (GigE) and / or InfiniBand (IB) network as the Lustre workstation. This makes it possible to read/write frames from the storage connected to the Visual Effects and Finishing workstation in the following circumstances:

- If the Lustre Media Server and the Visual Effects and Finishing workstation are connected to the same Storage Area Network (SAN) (for example, an Autodesk Stone Shared filesystem), you can use Autodesk Wiretap path translation to make the frames available through the Visual Effects and Finishing workstation on that filesystem, available to Incinerator. This configuration supports inline rendering and real-time playback as long as the SAN volume can accommodate that level of performance.
- If the Visual Effects and Finishing workstation is attached to a Stone Direct filesystem, it is possible to read/write frames on that Stone filesystem using Autodesk Wiretap over the Gigabit Ethernet (GigE) and / or IB network. Real-time playback and inline rendering are not supported in this configuration.

Refer to the *Autodesk Lustre 2009 User Guide* for more information on these configurations. Also check the *Autodesk 2009 Release Notes* for any late-breaking information on these configurations.

## Required Installation Media

You require the following media to install Incinerator 2009. If you did not receive this media with your shipment, contact Customer Support. See [“Contacting Customer Support”](#) on page 4.

Media	Format
Autodesk Distribution of 64-bit Red Hat® Enterprise Linux Workstation 4, Update 3	1 DVD
Discreet® Kernel Utility (DKU) for Linux (for your release)	1 DVD
Incinerator 2009 software	1 CD

**NOTE:** Refer to the *Autodesk 2009 Release Notes* for the correct DKU version for this release.

# 3

## Connecting Components and Peripherals

### Summary

<a href="#">Workflow for Connecting Components and Peripherals</a> .....	11
<a href="#">Verifying the Hardware Shipment</a> .....	12
<a href="#">Verifying the Hardware Environment</a> .....	12
<a href="#">Installing Rack-Mount Hardware Components</a> .....	15
<a href="#">Connecting Nodes and the Media Server to the Incinerator Network</a> .....	17
<a href="#">Connecting Workstations</a> .....	21
<a href="#">Connecting a Keyboard, Monitor, and Mouse to the KVM Switch</a> .....	21
<a href="#">Verifying BIOS Versions and Settings</a> .....	22

### Workflow for Connecting Components and Peripherals

The recommended steps for connecting Incinerator components are in the table that follows.

<b>Step:</b>	<b>Refer to:</b>
1. Verify the Incinerator hardware shipment.	<a href="#">“Verifying the Hardware Shipment”</a> on page 12.
2. Ensure you have the proper environment for your Incinerator system.	<a href="#">“Verifying the Hardware Environment”</a> on page 12.
3. Install the Lustre Media Server, Incinerator nodes, KVM (keyboard, video, and mouse) switch, InfiniBand switch, and Gigabit Ethernet (GigE) switch in the rack you selected.	<a href="#">“Installing Rack-Mount Hardware Components”</a> on page 15.
4. Connect the Incinerator Nodes and Lustre Media Server to the KVM switch, InfiniBand switch, and GigE switch.	<a href="#">“Connecting Nodes and the Media Server to the Incinerator Network”</a> on page 17.
5. Set up the workstation and connect it to the InfiniBand switch and GigE switch.	<a href="#">“Connecting Workstations”</a> on page 21.

Step:	Refer to:
6. Connect a keyboard, monitor, and mouse to the KVM switch so that you can log in to the Lustre Media Server and Incinerator Nodes directly.	<a href="#">“Connecting a Keyboard, Monitor, and Mouse to the KVM Switch”</a> on page 21.
7. After you install Linux, verify the BIOS version and settings of the hardware components. The BIOS of each of your hardware components is set by Autodesk prior to shipping.	<a href="#">“Verifying BIOS Versions and Settings”</a> on page 22.

## Verifying the Hardware Shipment

When you receive the shipment containing your Incinerator system, check all boxes for dents or other markings that may indicate damage during transport. If you suspect a component is damaged, carefully inspect it before setting up the system. If you receive a damaged component, call Customer Support. See [“Contacting Customer Support”](#) on page 4.

Also check the packing slip to ensure that you have received all the necessary items.

## Verifying the Hardware Environment

Hardware configuration should only be performed by an experienced hardware integrator familiar with the Linux operating system, PC workstations, and peripherals associated with professional high-performance video and film post production.

Your Incinerator system consists of high-performance hardware that requires an environment suited to its operational needs, as described in the following sections.

### Ensuring Proper Environmental Conditions

Use the following guidelines to ensure proper environmental conditions for all hardware components:

- Make sure the rack in which hardware components are installed is open or ventilated. Follow the ventilation specifications that apply to your system.
- Place all components in an air-conditioned environment. All hardware components generate heat and must be kept cool. Follow the air-conditioning specifications that apply to your system. For more information about the cooling requirements of your system, see [“Ensuring Proper Power and Air Conditioning Requirements”](#) on page 13.
- Keep all hardware components in a clean, dust-free location.
- Minimize vibration and humidity.
- Do not block the vents on the component housing.

- Do not drape anything, such as a jacket or a blanket, over hardware components.
- Minimize electromagnetic noise by separating digital data, power, and analog audio cables and running them in different cable ducts.

### Avoiding Damage from Static Electricity

When installing any hardware equipment, take the following precautions to prevent damage to sensitive components from static discharge:

- Make sure power is turned off on the component you are working on. It is a good idea to unplug components until all other connections are configured.
- Always wear a grounded static wrist strap. Attach the strap’s alligator clip to any grounded metal surface on the chassis of the component that you are working on.
- Do not handle any components unnecessarily, particularly boards and cards that slide in and out of slots on their parent hardware components.

### Grounding Hardware Components

It is important to properly ground any audio components used with Incinerator to avoid ground loops and humming. To ensure audio components are properly grounded, use the XLR-3 cables. Using any other cables may cause humming in the system.

### Ensuring Proper Power and Air Conditioning Requirements

This section summarizes the peak (at startup) power consumption and heat propagation of the components in the core Incinerator system. An example of an appropriate electrical circuit distribution for Incinerator is also provided. For detailed specifications on each hardware component (including noise output), see the documentation provided by the manufacturer.

#### HP Components

Consult the following table if your Incinerator system uses HP® components.

Component	Quantity	Amps (120V)	Amps (240V)	Watts	Heat (BTUs)
HP xw8600 (Lustre Media Server)	1	3.5	1.5	420	1433
HP xw9400 (Lustre Media Server)	1	3	1.5	360	1228
HP ProLiant DL160 G5 Server (HP xw8600 only)	8	2.27	2	2179	7435
HP ProLiant DL140 G3 Server (Incinerator Nodes)	8	3	1.5	2880	9827
HP xw8600 (Workstation)	1	3.5	1.5	420	1433
HP xw8400 (Workstation)	1	3.5	1.75	420	1433
InfiniBand switch	1	2	1	240	819

Component	Quantity	Amps (120V)	Amps (240V)	Watts	Heat (BTUs)
GigE switch	1	1	.5	120	409
KVM switch	1	1	.5	120	409
XR Storage chassis	1	5.5	2.75	660	2252
XE Storage chassis (expansion chassis)	1	5.5	2.75	660	2252

### IBM Components

Consult the following table if your Incinerator system uses IBM® components.

Component	Quantity	Amps (120V)	Amps (240V)	Watts	Heat (BTUs)
IBM eServer x346 (Lustre Media Server)	1	4	2	480	1638
IBM eServer x336 (Incinerator Nodes)	8	3	1.5	2880	9829
IBM ZPro 6223 (Workstation)	1	7	3.5	840	2866
InfiniBand switch	1	2	1	240	819
GigE switch	1	1	.5	120	409
KVM switch	1	1	.5	120	409
Storage chassis (XR/XE)	2	5.5	2.75	1320	4503
TOTAL				7080	20473

**NOTE:** If you are using IR storage, two chassis produce 3,686 BTUs (each chassis requires 4.5 120V Amps or 2.25 240V Amps). Substitute this BTU value for the one provided for the XR/XE storage, and recalculate the total BTUs produced by your Incinerator system.

### Example Circuit Layout

Based on the requirements provided above for IBM and HP components, in North America you need four 120V, 15A circuits to power the Incinerator components in the core system. See the following table for a suggestion on how to split the components between four 120V circuits.

Circuit	Components
1	4 Incinerator Nodes
2	4 Incinerator Nodes
3	Storage, InfiniBand switch, GigE switch, KVM switch
4	Workstation, Lustre Media Server, and monitors

For other locations around the world, use the number of amps provided by your power supply and the amps required by the components to determine how many circuits you need.

The Incinerator system components produce almost 20,000 BTUs of heat. You must have a climate control system with the capacity to maintain the temperature of these components while they are all operating.

## Installing Rack-Mount Hardware Components

You need sufficient space in your rack to install the Lustre Media Server, Incinerator Nodes, a KVM switch, an InfiniBand switch, and a GigE switch. The form factor units of these components are provided below, along with an example of one way to rack-mount the components.

### HP Components

Consult the following table if your Incinerator system uses HP components. Consult the illustration that follows the table for an example of how to organize the components in the rack.

Component	Quantity	Form Factor	Required Rack Space
HP xw8600 (Lustre Media Server)	1	5U	5U
HP xw9400 (Lustre Media Server)	1	5U	5U
HP ProLiant DL160 G5 Server	8	1U	8U
HP ProLiant DL140 G3 Server (Incinerator Nodes)	8	1U	8U
HP xw8600 (Workstation)	1	5U	5U
HP xw8400 (Workstation)	1	5U	5U
SilverStorm™ 9024 InfiniBand switch	1	1U	1U
NETGEAR® 24-Port GigE switch	1	1U	1U
Belkin® 16-Port KVM Switch	1	2U	2U
Storage chassis (XR/XE)	2	2U	4U
AJA Breakout Box (for HP xw8600)	1	1U	1U
DVS Breakout Box (for HP xw8400)	1	1U	1U
		TOTAL	27U

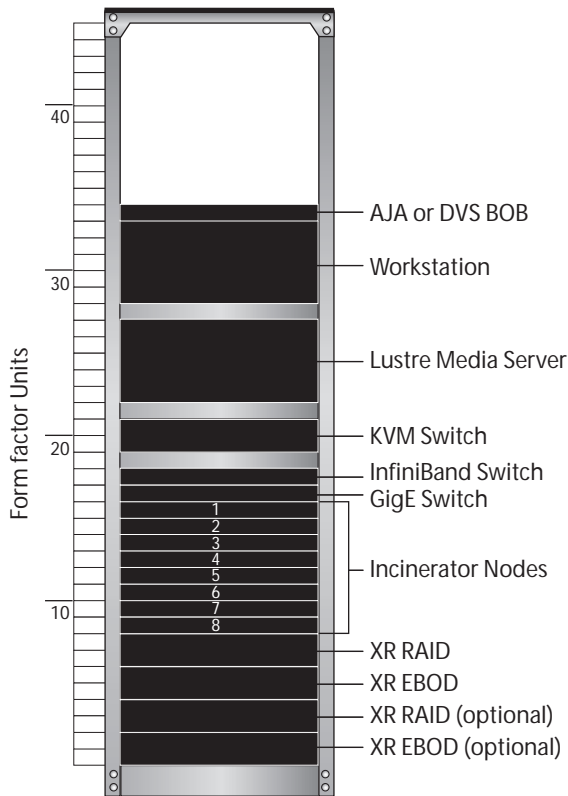

## IBM Components

Consult the following table if your Incinerator system uses IBM components. Consult the illustration that follows the table for an example of how you can organize the components in the rack.

Component	Quantity	Form Factor	Required Rack Space
IBM eServer x346 (Lustre Media Server)	1	2U	2U
IBM eServer x336 (Incinerator Node)	8	1U	8U
IBM ZPro 6223 (Workstation)	1	5U	5U
SilverStorm 9024 InfiniBand switch	1	1U	1U
NETGEAR 24-Port GigE switch	1	1U	1U
Belkin 16-Port KVM Switch	1	2U	2U
Storage chassis (IR)	2	3U	6U
DVS Breakout Box	1	1U	1U
TOTAL			26U

**NOTE:** If you are using IR storage, each storage chassis has a form factor of 3U, thus the required rack space for two of these chassis is 6U. Substitute this value for the one provided for the XR/XE storage, and recalculate the total rack space required for your Incinerator system.

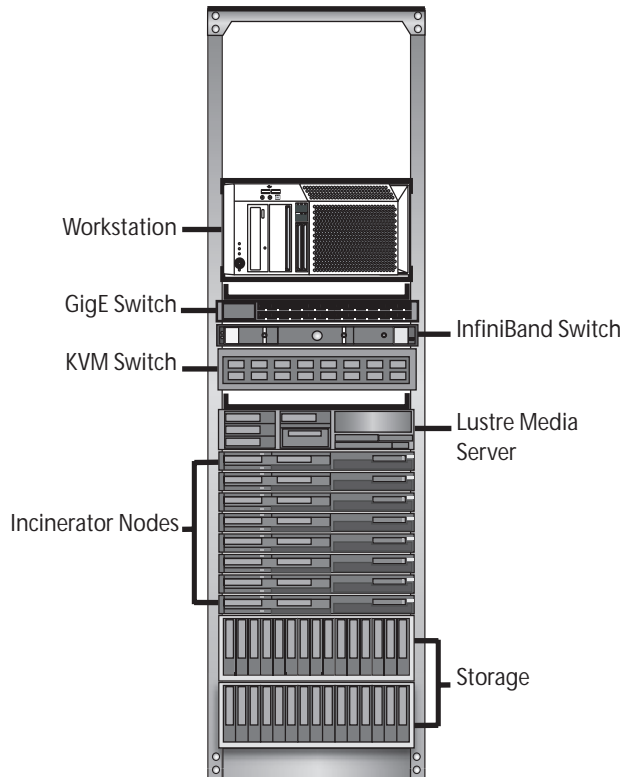

For detailed instructions on installing the components in the rack mount, see the documentation provided by the manufacturer.

## Connecting Nodes and the Media Server to the Incinerator Network

After you install the components in the rack, you are ready to connect the Incinerator Nodes and Lustre Media Server to the KVM, InfiniBand, and GigE switches.

Use the following diagrams as a reference for the Incinerator Node connections. The first is for an HP Incinerator Node and the second is for an IBM Incinerator Node.

### HP DL160 Incinerator Node

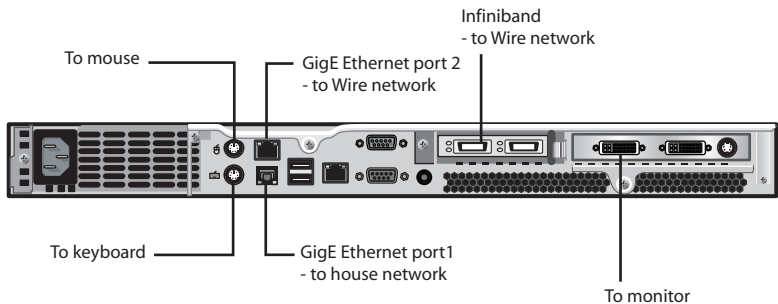

### HP DL140 Incinerator Node

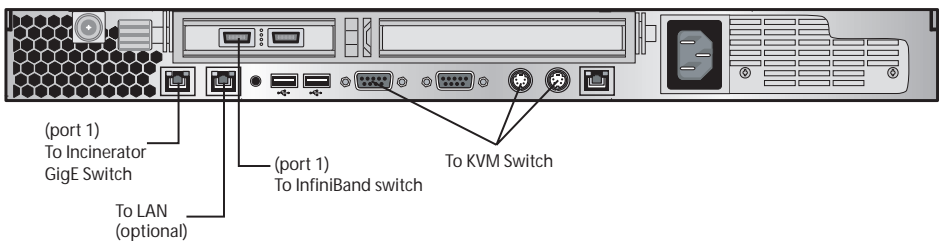

### IBM x336 Incinerator Node

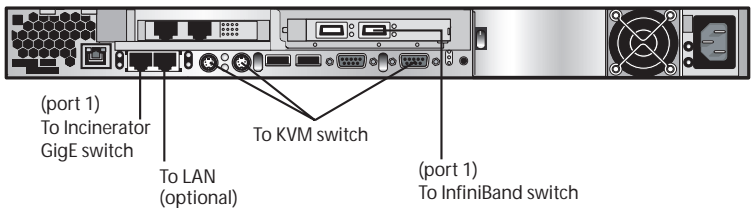

Use the following diagrams as a reference for the Lustre Media Server connections. The first two are for an HP Lustre Media Server and the third is for an IBM Lustre Media Server.

## HP xw8600 Lustrre Media Server

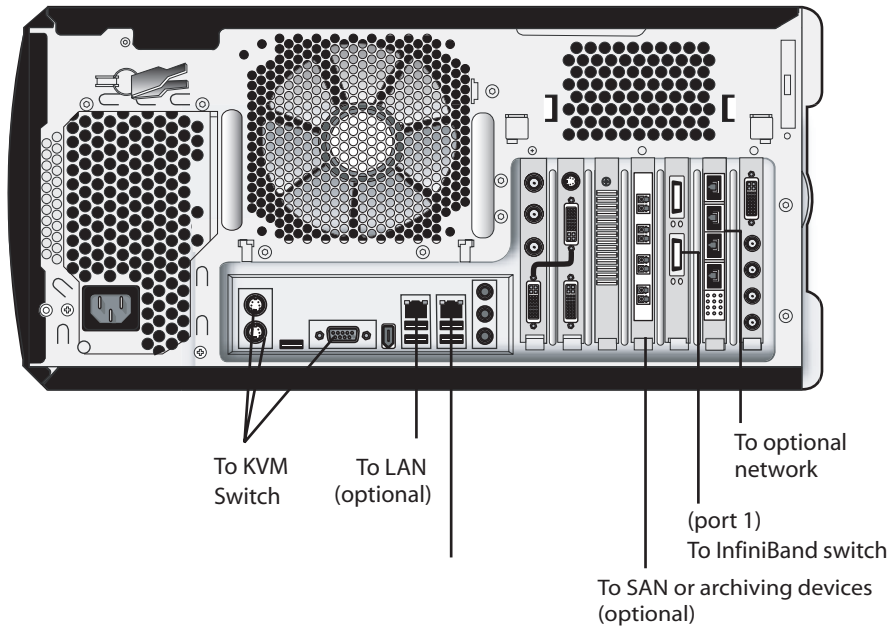

## HP xw9400 Lustrre Media Server

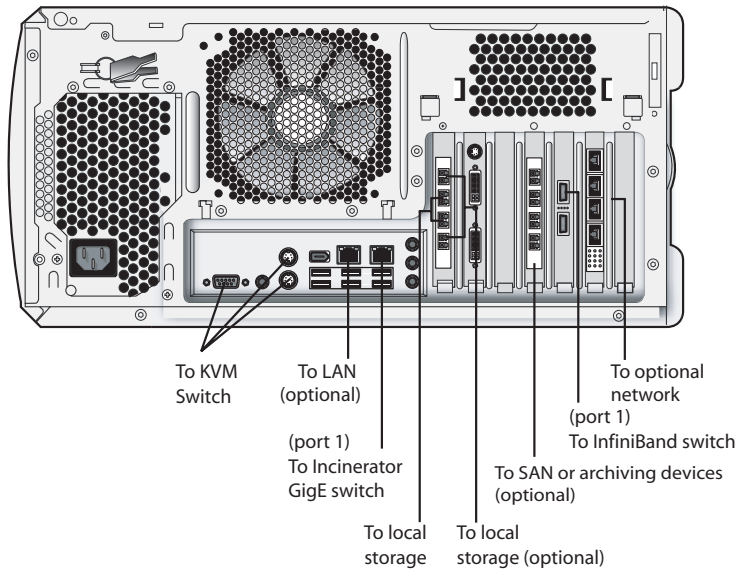

## IBM x346 Lustre Media Server

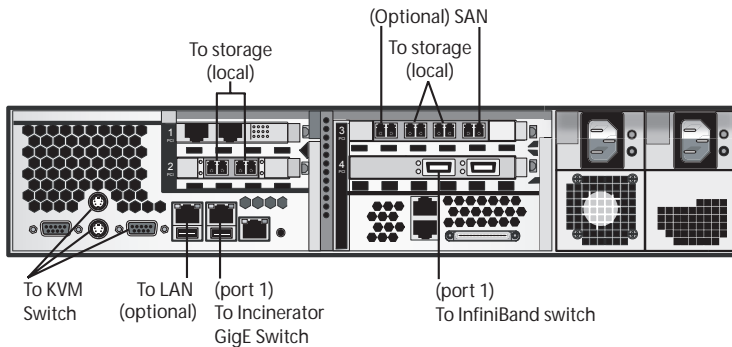

### To connect the Incinerator Nodes and the Lustre Media Server to the Incinerator network:

1. Connect the Incinerator Nodes and the Lustre Media Server to the KVM switch using the cables provided.

Because the cables for the KVM switch have three connectors, it is best to connect the Lustre Media Server and nodes to the KVM switch first. You can more easily get the InfiniBand and GigE cables around the KVM cables than the other way around.

Connect the nodes to the KVM switch in sequence. Consider connecting the Lustre Media Server to the last port on the switch.

2. On the Incinerator Nodes and Lustre Media Server, connect port 1 of the InfiniBand card to the InfiniBand switch. Refer to the appropriate diagram above for the location of port 1 on each component. The position of port 1 of the InfiniBand card is not identical on all components.

Connect the nodes to the InfiniBand switch in sequence so that you can easily match their IP address to their position.



**WARNING:** Do not connect the supplementary GigE ports on the PCI cards to the Incinerator GigE switch. Always connect port 1 of the onboard network interface to the Incinerator GigE switch.

3. On the Incinerator Nodes and Lustre Media Server, connect port 1 of the onboard network interface to the GigE switch. Refer to the appropriate diagram above for the location of port 1 on each component. The position of port 1 of the onboard network interface is not identical on all components.

Connect the nodes to the GigE switch in sequence so that you can easily match their IP address to their position.

## Connecting Workstations

Connecting the workstation requires that you first connect all peripherals to the workstation, and then connect the workstation to the Incinerator and GigE networks. Refer to the *Hardware Setup Guide* for your workstation for diagrams illustrating proper connections.

### Connecting Workstation Peripherals

Refer to the *Hardware Setup Guide* for your workstation for help connecting the following peripherals to the workstation:

- keyboard, mouse, and monitor
- calibration device
- control surface
- video I/O components
- high-speed data link (HSDL) devices

### Connecting the Workstation to the InfiniBand and GigE Networks

You must connect the Lustre workstation to the InfiniBand and GigE switch to add it to the Incinerator network.

#### To connect the Lustre workstation to the Incinerator network:

1. Connect the rightmost port of the InfiniBand card on the workstation to the InfiniBand switch.
2. Connect the onboard network interface to the GigE switch.

 **WARNING:** You must disconnect all devices from the supplementary GigE ports on the PCI card during the installation of the Incinerator and Lustre software.

## Connecting a Keyboard, Monitor, and Mouse to the KVM Switch

You must connect a keyboard, monitor, and mouse to the KVM switch so that you can manage the Incinerator Nodes and Lustre Media Server from one location. With the KVM switch, you can log in directly to each component.

It is not necessary to connect the workstation to the KVM switch because it has its own keyboard, monitor, and mouse. You can log in remotely to the workstation from any component on the Incinerator network.

## Verifying BIOS Versions and Settings

Autodesk configures the BIOS of all components prior to shipping. You should not normally need to adjust these settings. BIOS settings for the workstation, Lustre Media Server, Incinerator Nodes, and QLogic™ fibre channel adapter are provided here for informational purposes.

**NOTE:** The ATTO fibre channel adapter does not require specific BIOS settings. Settings for this adapter are defined in the *modprobe.conf* file.

### Lustre Workstation BIOS Settings

This section provides BIOS settings for both the HP xw8600, HP xw8400, and IBM ZPro 6223 Lustre workstations.

#### HP xw8600 BIOS Settings

The current certified system BIOS version for HP xw8600 is 1.01. The table below lists the correct BIOS settings for this workstation. Items not listed are set to their factory default.

You check the BIOS settings of the workstation as follows: log in directly to the workstation, initiate a reboot, and when the boot process starts, press **F10** to enter the system BIOS and examine the settings.

BIOS Menu	Item	Value
Storage, Storage options	SATA Emulation	Separate IDE Controller
Storage	Boot Order	Hard Drive, Integrated SATA Hard Drive, Integrated IDE Optical Drive USB Device
Power, OS Power Management	Runtime Power Management	Disabled
	Idle Power Savings	Normal
	ACPI S3 Hard Disk Reset	Disabled
Power, Hardware Power Management	SATA Power Management	Disabled
Advanced, Chipset/Memory	PCIe Lane Allocation (SLOT4: SLOT5)	x8:x8
Advanced, Device Options	S5 Wake on LAN	Disabled
Advanced, Slot7 - PCI-X 133	Speed	100Mhz PCI-X M1

### HP xw8400 BIOS Settings

The current certified system BIOS version for HP xw8400 is 1.15. The table below lists the correct BIOS settings for this workstation. Items not listed are set to their factory default.

You check the BIOS settings of the workstation as follows: log in directly to the workstation, initiate a reboot, and when the boot process starts, press **F10** to enter the system BIOS and examine the settings.

BIOS Menu	Item	Value
Storage, Storage options	SATA Emulation	Separate IDE Controller
Storage	Boot Order	Optical Drive USB Device Hard Drive, Integrated SATA Hard Drive, Integrated IDE
Storage, Power, OS Power Management	Runtime Power Management	Disabled
	Idle Power Savings	Normal
	ACPI S3 Support	Disabled
Storage, Advanced, Device Options	S5 Wake on LAN	Disabled
Advanced	Slot5 - PCI 133	Slot5 speed 100Mhz PCI-x m1

### IBM ZPro 6223 BIOS Settings

There are two models of the IBM ZPro 6223. Model 64U was the first model we shipped for Incinerator systems. This model was replaced by the 7DU model when the Restriction of Hazardous Substances (RoHS) European Union directive took effect.

- The current certified system BIOS version for the 64U model is 1.52A.
- The current certified system BIOS version for the 7DU model is 1.66A.

The table below lists the correct BIOS settings for both models of the 6223. Items not listed are set to their factory default.

You check the BIOS settings of the workstation as follows: log in directly to the workstation, initiate a reboot, and when the boot process starts, press **F1** to enter the system BIOS and examine the settings.

BIOS Menu	Item	Value
Devices and I/O Ports	Parallel Port	Disabled
	Serial ATA	Disabled
Startup Options	Planar PXE/DHCP Priority	Normal

BIOS Menu	Item	Value
	PCI Device Boot Priority	SLOT 1
	Boot Fail Count (available on the 1.66A BIOS only)	Disabled
Startup Options, Startup Sequence Options, Primary Startup Sequence	First Startup Device	CD/DVDROM
	Second Startup Device	Hard Disk
	Third Startup Device	Removable
Startup Options, Startup Sequence Options	Wake On Lan	Off
Advanced Setup, CPU Options	Hyper Threading Technology	Disabled

## Lustre Media Server BIOS Settings

This section provides BIOS settings for the HP xw8600, HP xw9400, and IBM ZPro 6223 Lustre Media Servers.

### HP xw8600 BIOS Settings

The current certified system BIOS version for the HP xw8600 is 1.01. The table below lists the correct BIOS settings for this system. Items not listed are set to their factory default.

You check the BIOS settings of the Lustre Media Server as follows: log in directly to the system, initiate a reboot, and when the boot process starts, press **F10** to enter the system BIOS and examine the settings.

BIOS Menu	Item	Value
Storage	Boot Order	Optical Drive USB Device Hard Drive, Integrated SATA Hard Drive, Integrated IDE
Advanced, OS Power Management	ACPI S3 Support	Disabled
Advanced, Chipset/Memory	ECC Support	Enabled
	Memory Scrubbing	Enabled
	Memory Node Interleave	Enabled
	PCI Serr# Generation	Enabled
	Net Watchdad Timer	Enabled
	ACPI Bus Segmentation	Disabled
	HPET	Enabled
I/O, Device Options	S5 Wake on LAN	Disabled

### HP xw9400 BIOS Settings

The current certified system BIOS version for the HP xw9400 is 1.05. The table below lists the correct BIOS settings for this system. Items not listed are set to their factory default.

You check the BIOS settings of the Lustre Media Server as follows: log in directly to the system, initiate a reboot, and when the boot process starts, press **F10** to enter the system BIOS and examine the settings.

BIOS Menu	Item	Value
Storage	Boot Order	Optical Drive USB Device Hard Drive, Integrated SATA Hard Drive, Integrated IDE
Advanced, OS Power Management	ACPI S3 Support	Disabled
Advanced, Chipset/Memory	ECC Support	Enabled
	Memory Scrubbing	Enabled
	Memory Node Interleave	Enabled
	PCI Serr# Generation	Enabled
	Net Watchdog Timer	Enabled
	ACPI Bus Segmentation	Disabled
	HPET	Enabled
I/O, Device Options	S5 Wake on LAN	Disabled

### IBM eServer x346 BIOS Settings

There are two models of the x346. Model 883741U was the first model we shipped. This model was replaced by the 88371RU model when the RoHS European Union directive took effect.

The current certified system BIOS version for both models is 1.13.

The table below lists the correct BIOS settings for both models of the x346. Items not listed are set to their factory default.

You check the BIOS settings of the Lustre Media Server as follows: log in directly to the system, initiate a reboot, and when the boot process starts, press **F1** to enter the system BIOS and examine the settings.

BIOS Menu	Item	Value
Startup Options	Planar PXE/DHCP Priority	Disabled
	Boot Fail Count	Disabled
Startup Options, Startup Sequence Options	Wake On Lan	Disabled
Advanced Setup Options, CPU Options	Hyper Threading Technology	Disabled

## Incinerator Node BIOS Settings

This section provides BIOS settings for the HP DL160, HP DL140, and IBM eServer x336 Incinerator Nodes.

### HP DL160 BIOS Settings

The current certified system BIOS version for the HP DL160 system is 04/09/2008. The table below lists the correct BIOS settings for this system. Items not listed are set to their factory default.

You check the BIOS settings of the node as follows: log in directly to the node, initiate a reboot, and when the boot process starts, press **F10** to enter the system BIOS and examine the settings.

BIOS Menu	Item	Value
Advanced, CPU Configuration	C1E Support	Enabled
	Hardware Prefetcher	Enabled
	Adjacent Cache line Prefetch	Disabled
	Intel® Virtualization Tech	Disabled
	Intel SpeedStep Tech	Enabled
Advanced, ACPI Configuration	Chipset ACPI configuration, High Precision Event Timer	Enabled
Advanced, PCI Bus Configuration	PCI Bus Compatibility Mode	GEN 2
	Video Card Support	Enabled
	Snoop Filter	Enabled
Boot, Boot Device Priority	1st	DVD
	2nd	SATA
	3rd	Embedded NIC 1

### HP DL140 BIOS Settings

The current certified system BIOS version for the HP DL140 system is 1.09. The table below lists the correct BIOS settings for this system. Items not listed are set to their factory default.

You check the BIOS settings of the node as follows: log in directly to the node, initiate a reboot, and when the boot process starts, press **F10** to enter the system BIOS and examine the settings.

BIOS Menu	Item	Value
Advanced	8042 Emulation Support	Disabled

### IBM eServer x336 BIOS Settings

There are two models of the x336 for this release. Model 883741U was the first model we shipped. These were replaced by the 88371RU model when the RoHS European Union directive took effect.

The current certified system BIOS version for both models is 1.13.

The table below lists the correct BIOS settings for both models of the x336 Incinerator Nodes. Items not listed are set to their factory default.

You check the BIOS settings of the node as follows: log in directly to the node, initiate a reboot, and when the boot process starts, press **F1** to enter the system BIOS and examine the settings.

BIOS Menu	Item	Value
Devices and IO Ports	PCI Slot 2	Disabled
Advanced Setup Options, CPU Options	Hyper Threading Technology	Disabled
Startup Options	Boot Fail Count	Disabled

## QLogic BIOS Settings

You use the QLogic QLA 2344 fibre channel adapters to connect storage to the IBM x346 Lustre Media Server.

The table below lists the correct BIOS settings for each port on each of the QLogic adapters. Items not listed are set to their factory default. The QLogic boards that Autodesk ships with the Incinerator system have these BIOS settings already configured. You should not need to change these settings.

To display the BIOS menu for the QLogic adapters, reboot the system and, when the QLogic board starts initializing during the reboot, press **CTRL+Q** to enter the QLogic BIOS settings.

**NOTE:** The QLogic board takes only a few seconds to initialize so you should follow the boot messages closely and be ready to press **CTRL+Q** as soon as you see the QLogic QLA board referenced in the boot messages.

BIOS Menu	Item	Value
Configuration Settings, Adapter Settings	BIOS Revision	1.43 <b>NOTE:</b> If the BIOS Revision is not 1.43, you must update the QLogic QLA board BIOS. Contact Autodesk Media and Entertainment Customer Support. Refer to " <a href="#">Contacting Customer Support</a> " on page 4. They will guide you through the update process.
	Data Rate	1, for ports attached to Stone Direct storage. Ports connected to an archiving device should be set to 0. This configures the port to Auto Select throughput.

<b>BIOS Menu</b>	<b>Item</b>	<b>Value</b>
	Fibre Channel Tape Support	Disabled for ports attached to Stone Direct storage or a SAN. Enabled for ports attached to a fiber channel tape device.
Configuration Settings, Advanced Adapter Settings	Execution Throttle	255 When connected to a SAN, set to 5
	LUNs per Target	64

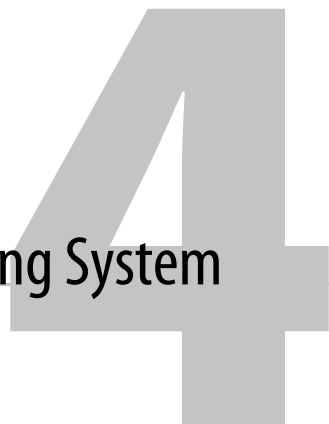

# Installing the Linux Operating System

## Summary

<a href="#">Choosing an Install Process</a> .....	29
<a href="#">Installing Linux Using a Centralized Install Process</a> .....	30
<a href="#">Installing Linux Using a Local Install Process</a> .....	32
<a href="#">Customizing Network Settings</a> .....	33

## Choosing an Install Process

There are two install processes for installing the Autodesk-customized version of 64-bit Red Hat Enterprise Linux Workstation (WS) in an Incinerator configuration: centralized and local.

- *Centralized Install Process*

In this install process you use the Lustre Media Server as a central repository for the Linux distribution, Discreet Kernel Utility (DKU), and network configuration information. All other components in the Incinerator configuration retrieve the Linux distribution, the DKU, and their network settings from the Lustre Media Server. This is the most efficient way to install Linux on all Incinerator components, and therefore the recommended install process when setting up a complete Incinerator configuration.

- *Local Install Process*

In this install process, you manually install Linux on a single Incinerator component. This is the recommended install process when you are integrating components into an Incinerator configuration in which the correct version of Linux is already installed, or should you ever need to reinstall Linux on an Incinerator component.

To carry out either of these install processes, you need a copy of the *Autodesk Red Hat Enterprise Linux Workstation 4, Update 3 Installation and Configuration Guide*. Both install processes refer you to this document for detailed instructions on installing Linux and the DKU on each Incinerator component. The latest version of the guide is available at [www.autodesk.com/lustre-documentation](http://www.autodesk.com/lustre-documentation) under the Operating Systems link.

## Installing Linux Using a Centralized Install Process

In a centralized install process, you first install Linux and the DKU on the Lustre Media Server. During this Linux installation, the contents of the Autodesk-customized 64-bit Red Hat Enterprise Linux DVD are copied onto the Lustre Media Server. During the DKU installation a copy of the contents of the DKU DVD are copied onto the Lustre Media Server, and a file containing default network information for all components in the Incinerator configuration is created on the Lustre Media Server.

After you complete the Linux and DKU installation on the Lustre Media Server, you install Linux and the DKU on each of the components in the Incinerator system. Each component retrieves and installs the Linux distribution, the DKU, and its network settings from the Lustre Media Server.

**NOTE:** In this process you must insert the Autodesk-customized 64-bit Red Hat Enterprise Linux WS 4, Update 3 DVD in the CD-ROM drive to start the Linux installation on each component. However, only the Lustre Media Server performs the full installation from the DVD. All other components use the DVD only to boot; after the boot, they perform the installation over the network from the distribution located on the Lustre Media Server.

### To install Linux using a centralized install process:

1. Log in to the Lustre Media Server through a console connected to the Keyboard, Video, Mouse (KVM) switch.
2. Install Linux and the DKU on the Lustre Media Server, along with default network configuration information for all other Incinerator components, by performing the three following steps. Consult the appropriate section of the *Linux RHEW 4 Update 3 Installation and Configuration Guide* for instructions on each step, as listed below.

Step:	Consult the section:
Prepare the Lustre Media Server for Linux installation	"Preparing Your System"
Install Linux using the <i>inclms</i> option at the Linux installation startup menu	"Installing Red Hat Enterprise Linux"
Install the DKU	"Installing the Discreet Kernel Utility"

**NOTE:** If you receive an error concerning a sound driver that cannot be located after DKU installation completes, confirm that you want to ignore the error.

3. If necessary, customize the hostnames, IP addresses, and subnet masks for each of the Incinerator components. See [“Customizing Network Settings in a Centralized Install Process”](#) on page 34.

**NOTE:** In most cases the default hostnames, IP addresses, and subnet masks do not require any change. It is therefore recommended that, unless you have a specific reason for changing these, you leave the default settings in place.

4. Prepare each of the Incinerator nodes for Linux installation, as described in the section “Preparing Your System” of the *Linux RHEW 4 Update 3 Installation and Configuration Guide*.
5. Switch the KVM to one of the Incinerator nodes.

**NOTE:** You may find it useful to install the nodes in sequence, from node 1 to node 8. This can make it easier to remember which nodes you have already installed on as you progress.

6. Install Linux and the Discreet Kernel Utility on the first Incinerator node, and configure the network information for the node by performing the following step, as described in the listed section of the *Linux RHEW 4 Update 3 Installation and Configuration Guide* for help.

**Step:**

Install Linux using the `incnode incnode=<node#>` option at the Linux installation startup menu, where `<node#>` is a number you assign to the node to distinguish it from the other nodes in the Incinerator configuration. For example, to install on node 2, type:

```
incnode incnode=2
```

**Consult the section:**

“Installing Red Hat Enterprise Linux”

When the Linux installation completes, it automatically launches the DKU installation. Network settings for the Incinerator node are configured during the DKU installation.

**NOTE:** You do not need to wait for the Linux installation to complete before starting the Linux installation on the next node in the sequence. As soon as the installation displays graphics, you can manually eject the DVD and proceed to the next step in this procedure.

7. Repeat the preceding two steps for each additional Incinerator node.
8. Switch the KVM to the workstation.

9. Install Linux and the Discreet Kernel Utility on the workstation, and configure the network information for that workstation as follows. Consult the referenced section of the *Linux RHEW 4 Update 3 Installation and Configuration Guide* for help.

Step:	Consult the section:
Prepare the workstation for Linux installation	"Preparing Your System"
Install Linux using the <code>incws incws=&lt;workstation#&gt;</code> option at the Linux installation startup menu, where <code>&lt;workstation#&gt;</code> is a number you assign to the workstation to distinguish it from the other workstations in the Incinerator configuration. For example, to install on workstation 1, type: <b>incws incws=1</b>	"Installing Red Hat Enterprise Linux"

When the Linux installation completes, it automatically launches the DKU installation. Network settings for the workstation are configured during the DKU installation.

10. Repeat the preceding two steps for each additional workstation in the Incinerator configuration.

## Installing Linux Using a Local Install Process

Use the following procedure to install Linux when you need to install Linux and the DKU, along with network configuration information, on a single Incinerator component.

### To install Linux using a local install process:

1. Prepare the component for Linux installation, as described in the section "Preparing Your System" of the *Linux RHEW 4 Update 3 Installation and Configuration Guide*.
2. Install Linux on the component using one of the following options at the Linux installation startup menu. Refer to the section "Installing Red Hat Enterprise Linux" of the *Linux RHEW 4 Update 3 Installation and Configuration Guide*.

To install on:	Use the option:
A Lustre Media Server	<code>inclms text</code>
An Incinerator node	<code>incnode_cd incnode=&lt;node#&gt;</code> where <code>&lt;node#&gt;</code> is an integer you assign to the node to distinguish it from the other nodes in the Incinerator configuration.
A workstation	<code>incws_cd incws=&lt;workstation#&gt;</code> where <code>&lt;workstation#&gt;</code> is an integer you assign to the workstation to distinguish it from the other workstations in the Incinerator configuration.

3. Install the DKU on the component. Refer to the section “Installing the Discreet Kernel Utility” of the *Linux RHEW 4 Update 3 Installation and Configuration Guide*.

Default network settings for the component are configured during the DKU installation.

4. Verify and, if necessary, customize the hostname, IP address, and subnet mask for the component to work with those of the other components in the Incinerator configuration. See [“Customizing Network Settings in a Centralized Install Process”](#) on page 34.

**NOTE:** In most cases the default hostname, IP address, and subnet mask do not require any change. It is therefore recommended that, unless you have a specific reason for changing these, you leave the default settings in place.

5. Ensure the */etc/hosts* file on the component contains the hostnames and IP addresses of all other components in the Incinerator configuration. You can edit the file using a text editor such as *nedit* or *vi*. You can use the *ping* command to validate the network settings.
6. From the component, log in to the Lustre Media Server as root and run the *keycheck* script. This enables the root user on the Lustre Media Server to log in to any component without being prompted for a password, making it simpler to execute remote commands from the Lustre Media Server. Type:

```
/usr/local/bin/keycheck.sh -g
```

## Customizing Network Settings

The Linux installation procedure automatically configures default hostnames, IP addresses, and subnet masks for all components in the Incinerator system. If necessary, you can modify these default settings for all or any one of the Incinerator components through the *incnetcfg* command.

**NOTE:** In most cases the default hostnames, IP addresses, and subnet masks do not require any change. It is therefore recommended that, unless you have a specific reason for changing these, you leave the default settings in place.

### Overview of the *incnetcfg* Command

The *incnetcfg* command is located in the */usr/local/bin* directory. It maintains a list of current network settings in the file */usr/discreet/DKU/INC/cluster.cfg*. You can use the command to:

- Configure network settings during a centralized install process. You run the command on the Lustre Media Server and the network settings you define are automatically propagated to a

component when you install Linux on that component. See [“Customizing Network Settings in a Centralized Install Process”](#) on page 34.

- Configure network settings for a single Incinerator component. See [“Customizing Network Settings for a Single Component”](#) on page 35.

## Customizing Network Settings in a Centralized Install Process

In a centralized installation install process, you customize network settings for all Incinerator components on the Lustre Media Server. You do this *after* you install Linux and the DKU on the Lustre Media Server and *before* you install Linux on the other components in the Incinerator configuration. When you subsequently install Linux on a component, the Linux installation retrieves the network settings for that component from the Lustre Media Server.

Use the first procedure in this section to configure the network settings for each component in the Incinerator configuration. Use the second procedure to reset network settings for all components in the Incinerator configuration to default values.

### To configure network settings for a centralized installation:

1. After you complete installation of Linux and the DKU on the Lustre Media Server (and before you install Linux on the other components in the Incinerator configuration), log in to the Lustre Media Server as root and open a Terminal.

2. In the Terminal, type:

```
incnetcfg -cluster
```

The *incnetcfg* utility launches, displays the current network settings for the first Incinerator component, and prompts you to confirm whether those settings are accurate.

3. Type one of the following.

Type:	If the network information is:
<b>n</b>	Inaccurate. In this case the utility prompts you for the correct network information for the first Incinerator component. At each prompt, enter the appropriate piece of network information and press <b>ENTER</b> . After you have entered all network information for the component, the utility displays a summary of what you entered and prompts for confirmation that the information is accurate.
<b>y</b> or <b>ENTER</b>	Accurate. In this case the utility displays the network information for the next Incinerator component.

4. Repeat the preceding step until the utility has network information for all Incinerator components in the configuration and exits.
5. Reboot the Lustre Media Server.

When you install Linux on the other Incinerator components, the Linux installation retrieves the network settings for the component from the Lustre Media Server.

**To reset network settings for a centralized install process:**

1. After you complete installation of Linux on the Lustre Media Server (and before you install Linux on the other Incinerator components), log in to the Lustre Media Server as root and open a Terminal.
2. In the Terminal, type the following to delete the file containing the network configuration information:

```
rm /usr/discreet/DKU/INC/cluster.cfg
```

3. In the Terminal, type:

```
incnetcfg -cluster auto
```

The *incnetcfg* utility launches, resets the network information for all Incinerator components to default values, displays those default values, and exits.

4. Reboot the component.

## Customizing Network Settings for a Single Component

Use the first procedure in this section to configure the network settings of a single Incinerator component. Use the second procedure to reset network settings for the component to default values. These procedures assume Linux and the DKU are installed on the component.

**To verify or configure network settings for a single component:**

1. Log in to the component as root and open a Terminal.
2. In the Terminal, type one of the following.

To configure settings for:	Type:
A Lustre Media Server	<b>incnetcfg -lms</b>
A workstation	<b>incnetcfg -wrks</b>
An Incinerator node, where <node#> is the node number you assigned to the node when you installed Linux.	<b>incnetcfg -incnode &lt;node#&gt;</b>

For example, to configure settings on Incinerator node 2, type:

```
incnetcfg -incnode 2
```

The *incnetcfg* utility launches, displays the current network settings for the component you specified, and prompts you to confirm whether those settings are accurate.

- Type one of the following.

Type:	If the network information is:
<b>n</b>	Inaccurate. In this case the utility prompts you for the correct network information. At each prompt, enter the appropriate piece of network information and press <b>ENTER</b> . After you have entered all network information for the component, the utility displays a summary of what you entered and prompts for confirmation that the information is accurate. Type <b>y</b> to indicate the network information is accurate.
<b>y</b>	Accurate.

- The utility displays the network information, saves any modifications to it, and exits.
- Reboot the component.

#### To reset network settings for a single component to default values:

- Log in to the component as root and open a Terminal.
- In the Terminal, type the following to delete the file containing the network configuration information:

```
rm /usr/discreet/DKU/INC/cluster.cfg
```

- In the Terminal, type:

```
incnetcfg -cluster auto
```

The *incnetcfg* utility launches, resets the network information to default values, displays those default values, and exits.

- Reboot the component.

# 5 Configuring Storage

## Summary

<a href="#">Workflow for Configuring Storage</a> .....	37
<a href="#">Connecting and Powering Up Storage</a> .....	38
<a href="#">Creating Hardware LUNs</a> .....	38
<a href="#">LUNs and Partitions</a> .....	39
<a href="#">Assembling the LUNs into a Logical Volume</a> .....	43
<a href="#">Creating the XFS Filesystem on the Storage Array</a> .....	46

## Workflow for Configuring Storage

You must connect some storage to the Lustre Media Server. In the Incinerator system, the Lustre Media Server is the gateway to the storage devices, providing the workstation and Incinerator Nodes access to the frames it stores. After the storage is connected, it must be configured to provide access to all frames and proxies. Properly configured storage is essential to ensuring real-time playback of 2K 10-bit frame sequences with grades and effects.

**NOTE:** This chapter describes how to configure a direct-attached storage. If you are also configuring a Storage Area Network (SAN), it is recommended that you configure the SAN prior to configuring a direct-attached storage.

Before you can configure the storage, the Lustre Media Server must be up, and running a custom distribution of 64-bit Red Hat Linux supplied by Autodesk, which includes a custom kernel, drivers, and other required utilities. If necessary, refer to [Chapter 4, “Installing the Linux Operating System.”](#) on page 29 for help installing Linux on the Lustre Media Server.

**NOTE:** For a list of storage configurations supported by your system, refer to the *Storage vs Systems Matrix*. If your storage configuration is an earlier generation than those listed in the *Storage vs Systems Matrix*, refer to the *Stone Direct Configuration Guide*.

See the following table for the recommended steps for configuring Incinerator storage.

Step:	Refer to:
1. Connect and power-up the storage devices.	<a href="#">"Connecting and Powering Up Storage"</a> on page 38.
2. Create the hardware LUNs (Logical UNits).	<a href="#">"Creating Hardware LUNs"</a> on page 38.
3. Configure the LUNs on the storage devices as Linux LVM partitions and verify that they are detected by the operating system.	<a href="#">"LUNs and Partitions"</a> on page 39.
4. Assemble all of the LUNs into a single logical volume. When assembled, all LUNs appear as one device to the operating system.	<a href="#">"Assembling the LUNs into a Logical Volume"</a> on page 43.
5. Create and mount the XFS filesystem on the storage array.	<a href="#">"Creating the XFS Filesystem on the Storage Array"</a> on page 46.

## Connecting and Powering Up Storage

You must connect the Lustre Media Server to the storage. Refer to the latest edition of the *Autodesk Stone Direct Configuration Guide* for illustrations demonstrating how to connect storage to your system.



**WARNING:** You must power down the Lustre Media Server before you connect the storage.

### To connect and power up the storage:

1. Power down the Lustre Media Server.
2. Use the optical cabling provided to connect the fiber channel adapter ports on the Lustre Media Server to the appropriate ports on the storage arrays, as illustrated in the *Autodesk Stone Direct Configuration Guide*.
3. Power up the storage arrays.
4. Power up the Lustre Media Server.

## Creating Hardware LUNs

Physical disks in storage devices are grouped into Logical Units (LUNs). The operating system sees each LUN as a single disk, even though each LUN is composed of several physical disks.

Refer to the latest edition of the *Autodesk Stone Direct Configuration Guide* for help creating LUNs on both IR-series and XR-series storage.

**NOTE:** LUN configurations are designed and tested by Autodesk to provide optimal performance for media playback on your workstation. Although the RAID management utilities (Stone Storage

Manager for XR-series storage, and Discreet Storage Manager for IR-series storage) let you customize LUN configuration manually, deviating from the documented LUN configuration procedures is not supported.

## LUNs and Partitions

Verify that the LUNs are set up properly before you assemble them into a single logical volume and create the filesystem.

### To partition the LUNs and ensure they are detected correctly:

1. Create the partition type on the LUNs. See [“Creating the Partition Type on the LUNs”](#) on page 39.
2. Check that all LUNs of the storage devices are detected by the operating system. See [“Checking Storage Device Detection”](#) on page 41.
3. Check that each LUN is partitioned as a Linux LVM partition. See [“Checking Storage Device Partitions”](#) on page 42.

## Creating the Partition Type on the LUNs

Use the following procedure to change the partition type of a LUN.

Before you check the number of LUNs detected by the operating system, ensure that:

- All storage devices are connected to the Lustre Media Server and are powered up.
- The Lustre Media Server is running.
- You have root access to the Lustre Media Server.

### To clear and recreate the partition type for a LUN:

1. Log in as root to the Lustre Media Server.
2. Reload the drivers for the fibre channel card. Do one of the following in a shell:
  - If your system uses a QLogic fibre channel card (IBM® systems), type:
 

```
rmmod qla2300
modprobe -v qla2300
```
  - If your system uses an ATTO fibre channel card (HP systems), type:
 

```
rmmod celerityfc
modprobe -v celerityfc
```

The fibre channel drivers reload and probe the attached storage devices.

3. Determine the device names of the LUNs with incorrect partition types. In a shell, type:
 

```
fdisk -l | grep dev
```
4. Note down the device names of the LUNs with incorrect partition types.
5. Clear the unsupported partition type on one of the LUNs using the *dd* command.



**WARNING:** Do not run the *dd* command on */dev/sda*, the system disk. Doing so may erase the partition table on that disk, making it impossible for you to reboot the machine. It may also erase data.

Type:

```
dd if=/dev/zero of=<disk_name> count=1
```

where *<disk\_name>* is the full name of a disk you noted down in the previous step. For example, if the disk is named */dev/sdb*, the command to clear the partition is:

```
dd if=/dev/zero of=/dev/sdb count=1
```

Typically device names start at */dev/sdb*. For example, the following table lists typical device names in a six LUN configuration.

LUN	Disk Name
1	<i>/dev/sdb</i>
2	<i>/dev/sdc</i>
3	<i>/dev/sdd</i>
4	<i>/dev/sde</i>
5	<i>/dev/sdf</i>
6	<i>/dev/sdg</i>

The existing partition on the LUN is cleared. You are ready to create a new partition on the LUN using the *fdisk* utility.

6. Start the *fdisk* utility for the LUN. Type:

```
fdisk <disk name>
```

where *<disk name>* is the full name of the disk cleared in step 2, such as */dev/sdb*.

The *fdisk* utility starts, checks the LUN, and then displays its prompt.

**NOTE:** When *fdisk* starts, a warning about the number of disk cylinders may appear. You can disregard this warning.

7. At the prompt, press **N** to display the partition creation menu.

The *fdisk* utility displays the type of partitions you can create (primary or extended) on the LUN.

8. Create a primary partition on the LUN by typing **p** at the prompt.
9. When prompted to enter a partition number, type **1** to make the primary partition the first one on the LUN.
10. When prompted to set the starting cylinder number, press **ENTER** to accept the default.
11. When prompted to set the ending cylinder number, press **ENTER** to accept the default.  
The *fdisk* prompt reappears. Next, set the type of partition to be created.
12. At the prompt, type **t** to set the partition type.  
You are prompted to enter the hexadecimal code of the partition type to be created on the LUN.
13. Create a Linux LVM partition by typing **8e** at the prompt.  
The *fdisk* utility sets the partition to be compatible with a RAID configuration and the following output appears:  
  

```
Changed system type of partition 1 to 8e (Linux LVM)
```

Only partitions set up for a Linux LVM configuration are supported on storage devices for Incinerator.
14. Save the new partition table by pressing **w** at the prompt.
15. Repeat steps 4 through 13 for each of the LUNs with an incorrect partition type.

## Checking Storage Device Detection

The storage devices must appear as the correct number of LUNs to the Lustre Media Server's operating system to be configured properly for your system.

### To check that storage devices are detected:

1. Log in as root to the Lustre Media Server.
2. View a list of LUNs detected for the storage devices attached to the Lustre Media Server.
  - If you are using IR-series storage, type:

```
cat /proc/scsi/scsi | grep -i discreet
```

All LUNs appear as disks in a list similar to the following example output. In this example, six LUNs are detected.

```
Vendor: DISCREET Model: 2Gb Fibre Raid Rev: 940
Vendor: DISCREET Model: 2Gb Fibre Raid Rev: 940
Vendor: DISCREET Model: 2Gb Fibre Raid Rev: 940
Vendor: DISCREET Model: 2Gb Fibre Raid Rev: 940
```

Vendor: DISCREET Model: 2Gb Fibre Raid Rev: 940

Vendor: DISCREET Model: 2Gb Fibre Raid Rev: 940

- If you are using XR-series storage, type:

```
cat /proc/scsi/scsi | grep -i autodesk
```

All LUNs appear as disks in a list similar to the following example output. Note that each RAID controller will be represented by its own “processor” LUN device. In this example, eight LUN devices are listed, but two of these are representing RAID controllers, which means that six LUNs are detected.

Vendor: AUTODESK Model: 4Gb Fibre Raid Rev: AD10

Vendor: AUTODESK Model: 4Gb Fibre Raid Rev: AD10

Vendor: AUTODESK Model: 4Gb Fibre Raid Rev: AD10

Vendor: AUTODESK Model: 4Gb Fibre Raid Rev: AD10

Vendor: AUTODESK Model: 4Gb Fibre Raid Rev: AD10

Vendor: AUTODESK Model: 4Gb Fibre Raid Rev: AD10

Vendor: AUTODESK Model: 4Gb Fibre Raid Rev: AD10

Vendor: AUTODESK Model: 4Gb Fibre Raid Rev: AD10

3. If the number of disks detected does not match the number of LUNs configured for your storage, do the following to troubleshoot the mismatch, then restart the Lustre Media Server and repeat steps 1 to 3 to ensure the number of disks the operating system detects equals the number of LUNs on the storage devices.
  - Ensure that all storage devices are connected properly and powered up.
  - Look at the status lights for each physical disk to verify that they are all online.
  - If you are using IR-series storage, check that the physical disks in the storage devices are organized into the correct number of LUNs using the Discreet Storage Manager application. See the *Discreet Storage Manager Installation and User's Guide, 3rd edition*.
  - If you are using XR-series storage, run the XR configuration utility again, or use the Stone Storage Manager to diagnose the problem further. Refer to the latest version of the *Autodesk Stone Direct Configuration Guide* for help running this utility.

## Checking Storage Device Partitions

Check that the storage LUNs are partitioned as Linux LVM partitions. If necessary, you must create new partitions to remove unsupported partition types (such as SGI® IRIX®) from the LUNs.

**To check storage device partitions:**

1. Log in as root to the Lustre Media Server.
2. View a list of LUNs for the storage devices attached to the Lustre Media Server to confirm that they are “Linux lvm” partitions. In a shell, type:

```
fdisk -l | grep dev
```

All LUNs appear as disks in a list similar to the following example. The example is for an eight LUN storage configuration.

```
Disk /dev/sdb: 726.2 GB, 726247931904 bytes
/dev/sdb1          1      88294  709221523+  8e  Linux LVM
Disk /dev/sdc: 726.2 GB, 726247931904 bytes
/dev/sdc1          1      88294  709221523+  8e  Linux LVM
Disk /dev/sdd: 726.2 GB, 726247931904 bytes
/dev/sdd1          1      88294  709221523+  8e  Linux LVM
Disk /dev/sde: 726.2 GB, 726247931904 bytes
/dev/sde1          1      88294  709221523+  8e  Linux LVM
Disk /dev/sdf: 726.2 GB, 726247931904 bytes
/dev/sdf1          1      88294  709221523+  8e  Linux LVM
Disk /dev/sdg: 726.2 GB, 726247931904 bytes
/dev/sdg1          1      88294  709221523+  8e  Linux LVM
Disk /dev/sdh: 726.2 GB, 726247931904 bytes
/dev/sdh1          1      88294  709221523+  8e  Linux LVM
Disk /dev/sdi: 726.2 GB, 726247931904 bytes
/dev/sdi1          1      88294  709221523+  8e  Linux LVM
```

The partition type should be one of the following.

Partition type:	Is correct for:
Linux LVM	All LUNs that are not part of a Stone Shared Storage Area Network (SAN). All LUNs starting from <code>/dev/sdb</code> , should be listed as this partition type. If this is not the case for any LUN, you must change its partition type to “Linux LVM”. Refer to <a href="#">“Creating the Partition Type on the LUNs”</a> on page 39. After you correct the partition type for each LUN, repeat this procedure to verify the partition types are now correct.
SGI disk label	All LUNs on a Stone Shared Storage Area Network (SAN).

## Assembling the LUNs into a Logical Volume

After you have verified that the storage is organized into the correct number LUNs and that each LUN is formatted as a Linux LVM partition, you must assemble the LUNs into a single logical volume on which you create the XFS filesystem.

**To assemble the LUNs into a logical volume:**

1. Verify that the LUN devices are detected by the operating system. Type:

```
fdisk -l | grep dev
```

All LUN devices appear in a list similar to the following example. The example is for an eight LUN storage configuration.

```
Disk /dev/sdb: 726.2 GB, 726247931904 bytes
/dev/sdb1          1      88294   709221523+  8e  Linux LVM
Disk /dev/sdc: 726.2 GB, 726247931904 bytes
/dev/sdc1          1      88294   709221523+  8e  Linux LVM
Disk /dev/sdd: 726.2 GB, 726247931904 bytes
/dev/sdd1          1      88294   709221523+  8e  Linux LVM
Disk /dev/sde: 726.2 GB, 726247931904 bytes
/dev/sde1          1      88294   709221523+  8e  Linux LVM
Disk /dev/sdf: 726.2 GB, 726247931904 bytes
/dev/sdf1          1      88294   709221523+  8e  Linux LVM
Disk /dev/sdg: 726.2 GB, 726247931904 bytes
/dev/sdg1          1      88294   709221523+  8e  Linux LVM
Disk /dev/sdh: 726.2 GB, 726247931904 bytes
/dev/sdh1          1      88294   709221523+  8e  Linux LVM
Disk /dev/sdi: 726.2 GB, 726247931904 bytes
/dev/sdi1          1      88294   709221523+  8e  Linux LVM
```

2. Create a physical volume on each of the LUN devices. Type:

```
pvcreate <list of devices>
```

where <list of devices> is a list of all LUN devices. For example, if you have eight LUN devices, ranging from */dev/sdb* to */dev/sdi*, you would type:

```
pvcreate /dev/sdb1 /dev/sdc1 /dev/sdd1 /dev/sde1 /dev/sdf1 /
dev/sdg1 /dev/sdh1 /dev/sdi1
```

3. Verify that the physical volumes were initialized correctly. Type:

```
pvscan -v
```

A list of all of the physical volumes you created appears. Each volume should contain “lvm2”. The following sample output is for the previous example of eight LUNs created on devices */dev/sdb* through */dev/sdi*.

```
Wiping cache of LVM-capable devices
Wiping internal VG cache
Walking through all physical volumes
```

```

PV /dev/sdb1          lvm2 [676.37 GB]
PV /dev/sdc1          lvm2 [676.37 GB]
PV /dev/sdd1          lvm2 [676.37 GB]
PV /dev/sde1          lvm2 [676.37 GB]
PV /dev/sdf1          lvm2 [676.37 GB]
PV /dev/sdg1          lvm2 [676.37 GB]
PV /dev/sdh1          lvm2 [676.37 GB]
PV /dev/sdi1          lvm2 [676.37 GB]
Total: 8 [5.28 TB] / in use: 0 [0  ] / in no VG: 8 [5.28 TB]

```

4. Create the volume group “vg00” from the physical volumes you created in the preceding step. Type:

```
vgcreate vg00 <list of volumes>
```

where <list of volumes> is the list of physical volumes you created in the preceding step. The following sample output continues the previous example of eight LUNs.

```
vgcreate vg00 /dev/sdb1 /dev/sdc1 /dev/sdd1 /dev/sde1 /dev/
sdf1 /dev/sdg1 /dev/sdh1 /dev/sdi1
```

5. Verify the volume was created and obtain the value of the “Free PE / Size” field. Type:

```
vgdisplay -v
```

In the output, find the line that contains the “Free PE / Size” field and write down the value of the “Free PE”. For example, in the following example output the “Free PE” value is 1385192.

```
Free PE / Size          1385192 / 5.28 TB
```

6. Create a logical volume on “vg00”. Type:

```
lvcreate -l <calculated_value> -i <#_of_physical_volumes> -I 32 -n lvol1 vg00
```

where <calculated\_value> is the “Free PE” value you noted in the preceding step and <#\_of\_physical\_volumes> is the number of physical volumes. If we continue with the example used in the previous steps, we would type:

```
lvcreate -l 1385200 -i 8 -I 32 -n lvol1 vg00
```

The output confirms the creation of the logical volume:

```
Logical volume "lvol1" created
```

## Creating the XFS Filesystem on the Storage Array

Create the XFS filesystem on the storage array and then mount this filesystem on the Lustre Media Server.

The XFS filesystem is designed to provide high-performance access for large storage arrays. When properly configured, the XFS filesystem ensures that Incinerator Nodes can access frames from the storage fast enough to support 2K playback in real-time with applied grades and effects.



**WARNING:** The following procedure reformats the storage. All existing data will be deleted. Back up any data that you want to keep from the storage before continuing with this procedure. See your system administrator for help determining and carrying out the backup procedures used in your facility.

### To create and mount the XFS filesystem on the storage device:

1. Identify the optimal *agsize* value for your array by running the *mkfs.xfs* command. Type:
 

```
mkfs.xfs -i size=1024 -d agcount=128 -f /dev/vg00/lvol1
```

This command displays diagnostics information similar to the following:

```
meta-data=/dev/vg00/lvol1 isize=1024 agcount=126, agsize=1066667 blks
          =                               sectsz=512 attr=0
data     =                               bsize=4096 blocks=134400000, imaxpct=25
          =                               sunit=16   swidth=64 blks, unwritten=1...
```

Note the *agsize* on the first line, and the *sunit* and *swidth* on the fourth line. Depending on the values of *sunit* and *swidth*, you perform one of the three steps that follow.

2. If the values of *sunit* and *swidth* are both equal to 0, multiply the *agsize* value by the block size value of 4096. For example:

$$1066667 * 4096 = 4369068032$$

Proceed to step 5 using the value calculated above as the *agsize*.

3. If the command displays a warning message similar to the following:

```
Warning: AG size is a multiple of stripe unit. This can cause performance problems
by aligning all AGs on the same disk. To avoid this, run mkfs with an AG size that
is one stripe unit smaller, for example 1049984.
```

```
meta-data=/dev/vg00/lvol1 isize=1024 agcount=126, agsize=1050000 blks
        =                               sectsz=512 attr=0
data     =                               bsize=4096 blocks=13400000, imaxpct=25
        =                               sunit=16   swidth=240 blks, unwritten=1...
```

Multiply the *agsize* value by the *block size* value of 4096, and subtract the *sunit* value multiplied by 4096, For example:

$$1050000 * 4096 = 4300800000$$

$$16 (\text{sunit}) * 4096 = 65536$$

$$4300800000 - 65536 = 4300734464$$

Proceed to step 5 using the value calculated above as the *agsize*.

4. If the values of *sunit* and *swidth* are not equal to 0, and no warning message appears, proceed to step 6 using the *agsize* value displayed by the command.
5. Run the *mkfs.xfs* command again to create the XFS filesystem on the device */dev/vg00/lvol1* using the value calculated in one of the previous steps. Type:

```
mkfs.xfs -i size=1024 -d agsize=<new agsize> -f /dev/vg00/
lvoll
```

For example:

```
mkfs.xfs -i size=1024 -d agsize=4369068032 -f /dev/vg00/
lvoll
```

The filesystem is created on the storage array.

6. Create the directory that will serve as the mount point for the filesystem. Type:

```
mkdir /mnt/md0
```
7. Mount the XFS filesystem you created on the logical volume */dev/vg00/lvol1*, on the */mnt/md0* mount point. Type:

```
mount -av -t xfs /dev/vg00/lvol1 /mnt/md0
```

The filesystem is mounted as */mnt/md0*.

8. Confirm that the storage is now mounted. Type:

**df -k**

The output should display `/dev/vg00/lvol1` as mounted on `/mnt/md0`. For example:  
`/dev/vg00/lvol1 3299635072 2176 3299632896 1% /mnt/md0`

9. An entry for the `/mnt/md0` mountpoint should already exist in the `/etc/fstab` file to automatically mount the filesystem. If the entry is not present add the following line in `/etc/fstab`:

```
/dev/vg00/lvol1 /mnt/md0 xfs rw,noatime
```



# Installing Incinerator Software

## Summary

<a href="#">Workflow for Installing Incinerator Software</a> .....	49
<a href="#">Copying the Application Software onto the Lustre Media Server</a> .....	49
<a href="#">Installing the Lustre Media Server Software</a> .....	50
<a href="#">Installing the Incinerator Node Software</a> .....	51
<a href="#">Installing the Workstation Software</a> .....	51

## Workflow for Installing Incinerator Software

The recommended steps for installing Incinerator and Lustre software are as follows. In this workflow you copy the software for all components onto the Lustre Media Server, and then perform the software install on each component from the Lustre Media Server.

This workflow assumes all components are running Linux. For help installing Linux in an Incinerator configuration, see [Chapter 4, “Installing the Linux Operating System.”](#) on page 29.

Step:	Refer to:
1. Copy the contents of the application CD onto the Lustre Media Server.	<a href="#">“Copying the Application Software onto the Lustre Media Server”</a> on page 49.
2. Install server software on the Lustre Media Server.	<a href="#">“Installing the Lustre Media Server Software”</a> on page 50.
3. Install inline rendering software on each Incinerator Node.	<a href="#">“Installing the Incinerator Node Software”</a> on page 51.
4. Install Lustre on the grading workstation.	<a href="#">“Installing the Workstation Software”</a> on page 51.

## Copying the Application Software onto the Lustre Media Server

Copy the contents of the application CD onto the Lustre Media Server so you can install the application software for each component in the workgroup from the Lustre Media Server.

**To install the Server software on the Lustre Media Server:**

1. On the Lustre Media Server, log in as root.
2. Insert the Incinerator 2009 CD in the CD-ROM drive.
3. Verify that the CD-ROM drive is mounted by typing:

```
df -k | grep cdrom
```

If you see `/mnt/cdrom` (or `/media/cdrom`) in the system response, the CD-ROM drive is mounted. If the drive is not mounted, mount it manually by typing:

```
mount /mnt/cdrom
```

4. Create a directory on the Lustre Media Server to hold the contents of the CD by typing:

```
mkdir -p /usr/discreet/DKU/INC/lustre_2009CD
```

5. Copy the contents of the CD onto the Lustre Media Server by typing:

```
cp -r /mnt/cdrom/* /usr/discreet/DKU/INC/lustre_2009CD
```

## Installing the Lustre Media Server Software

To install Incinerator software on the Lustre Media Server, run the Lustre Media Server installation script. The installation script starts the *BrowseD* daemon when the Lustre Media Server installation process is complete, and configures it to start on reboot by default.

**NOTE:** After you install the *BrowseD* license, you must restart the *BrowseD* daemon.

**To install the Server software on the Lustre Media Server:**

1. On the Lustre Media Server, log in as root.
2. Navigate to the directory containing the installation script by typing:

```
cd /usr/discreet/DKU/INC/lustre_2009CD/lustre_2009
```

3. Start the installation script for the Lustre Media Server. Type:

```
./INSTALL_LUSTRE_2009_SERVER
```

The Incinerator package is installed on the Lustre Media Server. The installation script installs and configures Incinerator daemons and utilities.

4. Reboot the Lustre Media Server.

The *BrowseD* daemon is started automatically during the reboot.

## Installing the Incinerator Node Software

To install both inline and background rendering software on an Incinerator Node, use *ssh* to log in remotely to the node from the Lustre Media Server and run the script. You must repeat this procedure for each node.

The installation script starts the *renderd* daemon when the installation process is complete.

**NOTE:** To complete the following procedure, the Incinerator private GigE network must be fully installed and functioning.

### To install inline and background rendering software on the Incinerator Nodes:

1. Log in to the Lustre Media Server as root.
2. Open a secure shell to log in to the node. Type:

```
ssh <NODE_IP>
```

where <NODE\_IP> is the GigE IP address of the node you want to log in to. For example, to log in to the first node, type:

```
ssh 10.10.10.101
```

3. Navigate to the directory containing the installation script by typing:

```
cd /hosts/<lms_hostname>/usr/discreet/DKU/INC/  
lustre_2009CD/lustre_2009
```

Where <lms\_hostname> is the hostname of the Lustre Media Server. In a default configuration this would be:

```
cd /hosts/server/usr/discreet/DKU/INC/lustre2009CD/  
lustre_2009
```

4. Start the installation. Type:

```
./INSTALL_LUSTRE_2009_RENDEERNODE
```

The Incinerator Node package is installed.

5. Reboot the Incinerator node.
6. Repeat these instructions to install the inline rendering software on each Incinerator Node.

## Installing the Workstation Software

To install Lustre on the workstation, use *ssh* to log in remotely to the workstation from the Lustre Media Server and launch the workstation installation script.

**NOTE:** To complete the following procedure, the Incinerator private GigE network must be fully installed and functioning.

**To install the workstation software:**

1. Log in to the Lustre Media Server as root.
2. Open a secure shell to log in to the workstation. Type:

```
ssh <WS_IP>
```

where <WS\_IP> is the GigE IP address of the workstation. For example, type:

```
ssh 10.10.10.201
```

3. Navigate to the directory containing the installation script by typing:

```
cd /hosts/<lms_hostname>/usr/discreet/DKU/INC/  
lustre_2009CD/lustre_2009
```

Where <lms\_hostname> is the hostname of the Lustre Media Server. In a default configuration this would be:

```
cd /hosts/server/usr/discreet/DKU/INC/lustre_2009CD/  
lustre_2009
```

4. Start the installation. Type:
- ```
./INSTALL_LUSTRE_2009_INCINERATOR
```

**NOTE:** During installation, if you are prompted to confirm whether you want to start Backburner Manager automatically, respond that you do not want to do so.

The Incinerator package is installed on the workstation.

5. Reboot the workstation.



# Licensing and Starting Incinerator

## Summary

- [Workflow for Licensing, Configuring, and Using Incinerator](#) ..... 53
- [Determining the License Codes You Require](#) ..... 54
- [Obtaining the Imhostids](#) ..... 54
- [Requesting Incinerator License Codes](#) ..... 55
- [Installing the License Server](#) ..... 56
- [Creating the License File for the License Server](#) ..... 56
- [Starting the License Server](#) ..... 57
- [Installing the BrowseD License on the Lustre Media Server](#) ..... 58
- [Installing Incinerator Node Licenses](#) ..... 58
- [Installing the Workstation License](#) ..... 59
- [Configuring Incinerator Daemons](#) ..... 60
- [Using Lustre with Incinerator](#) ..... 62

## Workflow for Licensing, Configuring, and Using Incinerator

The recommended steps for licensing, configuring, and using Incinerator are as follows.

| Step:                                                                                    | Refer to:                                                                      |
|------------------------------------------------------------------------------------------|--------------------------------------------------------------------------------|
| 1. Determine the license codes you require.                                              | <a href="#">“Determining the License Codes You Require”</a> on page 54.        |
| 2. Obtain the <i>Imhostid</i> of the workstation for the Incinerator only.               | <a href="#">“Obtaining the Imhostids”</a> on page 54.                          |
| 3. Request license codes from the Autodesk Licensing Department.                         | <a href="#">“Requesting Incinerator License Codes”</a> on page 55.             |
| 4. Install the license server on the Lustre Media Server.                                | <a href="#">“Installing the License Server”</a> on page 56.                    |
| 5. After you receive your license codes, set up the license file for the license server. | <a href="#">“Creating the License File for the License Server”</a> on page 56. |

| Step:                                                                           | Refer to:                                                                               |
|---------------------------------------------------------------------------------|-----------------------------------------------------------------------------------------|
| 6. Start the license server.                                                    | <a href="#">“Starting the License Server”</a> on page 57.                               |
| 7. Create the <i>BrowseD</i> license file on the Lustre Media Server.           | <a href="#">“Installing the BrowseD License on the Lustre Media Server”</a> on page 58. |
| 8. Install the Incinerator node licenses.                                       | <a href="#">“Installing Incinerator Node Licenses”</a> on page 58.                      |
| 9. Install the workstation license.                                             | <a href="#">“Installing the Workstation License”</a> on page 59.                        |
| 10. (Optional) configure Incinerator daemons.                                   | <a href="#">“Configuring Incinerator Daemons”</a> on page 60.                           |
| 11. Start Lustre on the workstation and set up your project to use Incinerator. | <a href="#">“Using Lustre with Incinerator”</a> on page 62.                             |

## Determining the License Codes You Require

You must license the following applications and daemons to run Lustre with Incinerator.

| Application/Daemon                                    | Enables                                                                           | License location:     |
|-------------------------------------------------------|-----------------------------------------------------------------------------------|-----------------------|
| <i>BrowseD</i> daemon                                 | High-speed frame transfers over InfiniBand.                                       | Lustre Media Server   |
| <i>renderd</i> daemon                                 | Inline rendering on Incinerator Nodes                                             | Lustre Media Server   |
| (Optional) Burn for Lustre                            | Background rendering on Incinerator nodes or dedicated background rendering nodes | Lustre Media Server   |
| Lustre with Incinerator for the Lustre Master Station | Lustre application with Incinerator features                                      | Lustre Master Station |
| Lustre with Incinerator for the Lustre Station        | Lustre application with Incinerator features                                      | Lustre Station        |

**NOTE:** Licenses for *renderd* and Burn for Lustre are managed by a license server you install on the Lustre Media Server.

## Obtaining the *Imhostids*

To obtain license codes for Incinerator, you must generate an *Imhostid* for the Lustre Media Server and for the Lustre workstation.

**To obtain the *Imhostids* for Incinerator:**

1. Log in to the Lustre Media Server as root.
2. Navigate to the Lustre directory. Type:

```
cd /usr/autodesk/lustre_2009
```

3. Run the *lmhostid* utility to display a unique *lmhostid* for the machine. Type:

```
./lmhostid
```

A message appears that includes a line indicating the *lmhostid* of the machine:

```
The FLEXlm host ID of this machine is "<lmhostid>"
```

4. Note down the *lmhostid*.
5. Repeat the preceding steps on the workstation.

## Requesting Incinerator License Codes

You can obtain license codes for Incinerator from the Autodesk Media and Entertainment Licensing Department by e-mail, telephone, or fax. All license codes obtained by e-mail, fax or telephone are temporary 30-day licenses that you use until your permanent license is confirmed and delivered.

**NOTE:** For emergencies, you can acquire an immediate temporary license code by going to the Autodesk Registration Web page ([www.autodesk.com](http://www.autodesk.com), clicking the Support link, selecting your product, then clicking Register Your Product and following the step-by-step instructions). A 4-day license code is e-mailed to the address you provide.

### To obtain license codes by e-mail or fax:

- Send the *lmhostid* of the Lustre Media Server and workstation to the Licensing Department to receive all license codes for the components in your Incinerator system.

| To submit the form by: | Use:                                                                     |
|------------------------|--------------------------------------------------------------------------|
| E-mail                 | <a href="mailto:me.licensing@autodesk.com">me.licensing@autodesk.com</a> |
| Fax                    | 1-514-954-7254                                                           |

You will receive your temporary license code within eight business hours.

### To obtain license codes by telephone:

- Speak to a licensing representative by calling the Licensing Department toll-free in North America at 1-800-925-6442 between 9 AM and 5:30 PM eastern standard time (EST).

Outside of North America, call 1-415-507-5256 between 7 AM and 3 PM EST. Be sure to have the *Imhostid* of the Lustre Media Server and workstation in hand.

## Installing the License Server

The license server runs on the Lustre Media Server and manages the licenses for the *renderd* daemon running on each Incinerator Node. If you configure background rendering, it also manages the Burn for Lustre licenses for each node.

Use the following procedure to install the license server on the Lustre Media Server.

**NOTE:** The license server installation script is included on the application CD. It is copied onto the Lustre Media Server when you copy the contents of the application CD onto the Lustre Media Server in preparation for Incinerator software installation. For help performing the copy refer to [“Copying the Application Software onto the Lustre Media Server”](#) on page 49.

### To install the license server:

1. Log in to the Lustre Media Server as *root*.
2. Navigate to the directory containing the license server installation script. Type:

```
cd /usr/discreet/DKU/INC/lustre/lustre_2009CD/  
lustre_2009_Renderer_license_daemon
```

**NOTE:** Be sure to type the above as a single command line (not two command lines).

3. Start the installation script by typing:

```
./INSTALL_LINUX
```

## Creating the License File for the License Server

After you receive your license codes, you create the license server license file on the Lustre Media Server and add the license information to it.

The license server file you create is */usr/discreet/licserv/licenses/DL\_license.dat*. You add keywords to it that identify the license server followed by license strings for the *renderd* and Burn for Lustre features. The keywords are listed below. The licensing department provides you with these keywords and the values associated with them when you request your license codes. You add these keywords at the top of the license file.

| Keyword    | Description                                                                                                 |
|------------|-------------------------------------------------------------------------------------------------------------|
| SERVER     | Specifies the hostname of the license server from which to obtain the license, followed by its MAC address. |
| VENDOR     | Specifies the daemon that is serving the license.                                                           |
| USE_SERVER | Indicates whether the system should obtain its license from a license server.                               |

#### To create the license server on the Lustre Media Server:

1. Log in as root to the Lustre Media Server.
2. Navigate to the licenses directory by typing:  
**cd /usr/discreet/licserv/licenses**
3. Create a file called *DL\_license.dat* in the directory by typing:  
**touch DL\_license.dat**
4. Open the *DL\_license.dat* file in a text editor.
5. Copy and paste the SERVER, VENDOR, and USE\_SERVER keywords, as well as the license strings for the *renderd* feature and Burn for Lustre feature into the file. In the text you receive from the licensing department, the *renderd* feature appears as `lustre_incrdr_r_2009_L` and the Burn for Lustre feature appears as `lustre_bgrdr_r_2009_L`.

This license file you create should look similar to the following shortened example:

```
SERVER server 0011258D1A76
VENDOR lustre
USE_SERVER
FEATURE lustre_incrdr_r_2009_L lustre <...>
FEATURE lustre_bgrdr_r_2009_L lustre <...>
```

6. Save and close the license file.

## Starting the License Server

After you install the license server, and create the license file for it, start it using the following procedure.

#### To start the license server:

1. Log into the Lustre Media Server as root.
2. In a shell, type:

```
/etc/init.d/license_server start
```

**NOTE:** The license server starts/stops automatically when the machine is booted/shut down. You can stop and restart the server manually by running one of the following commands:

```
/etc/init.d/license_server stop
```

```
/etc/init.d/license_server restart
```

## Installing the BrowseD License on the Lustre Media Server

To install the BrowseD license, you must create the *BrowseD* license file on the Lustre Media Server, and copy the license string for the *BrowseD* feature into that file.

### To configure the BrowseD license on the Lustre Media Server:

1. Log in as root to the Lustre Media Server.
2. Navigate to the licenses directory by typing:
 

```
cd /usr/local/flexlm/licenses
```
3. Create a file called *DL\_license.dat* in the directory by typing:
 

```
touch DL_license.dat
```
4. Open the *DL\_license.dat* file in a text editor and copy and paste the license strings for the *BrowseD* feature into the file. The *BrowseD* feature appears as *lustre\_browsed\_ib\_r\_2009\_L* in the text you receive from the licensing department.

The resulting license file should look similar to the following shortened example:

```
FEATURE lustre_browsed_ib_r_2009_L lustre <...>
```

5. Save and close the license file.
6. To enable the license, restart the *BrowseD* daemon by running the following command:

```
/etc/init.d/browsed_2009 restart
```

## Installing Incinerator Node Licenses

You must configure each Incinerator node to contact the license server on the Lustre Media Server to obtain its license. You do this by creating a license file on each Incinerator Node that identifies the license server running on the Lustre Media Server. The node contacts the license server to obtain its license.

You add three keywords to the license file to identify the license server: SERVER, VENDOR, and USE\_SERVER. The licensing department provides you with these keywords and the values associated with them when you request your license codes.

**To configure the Incinerator Node license:**

1. As root on the Lustre Media Server, log in to the Incinerator Node by typing:

```
ssh <NODE_HOSTNAME>
```

where <NODE\_HOSTNAME> is the host name of the node you are logging in to.

You must provide the user name and password to log in to the node. The default password for the root user is `password`.

2. Navigate to the licenses directory by typing:

```
cd /usr/local/flexlm/licenses
```

3. Create a file called *DL\_license.dat* in the directory by typing:

```
touch DL_license.dat
```

4. Open the *DL\_license.dat* file in a text editor and copy and paste the SERVER, VENDOR, and USE\_SERVER keywords from the license server license file into the Incinerator Node license file. The strings for these keywords are provided by the licensing department.

The resulting license file should look similar to the following example:

```
SERVER server 0011258D1A76
VENDOR lustre
USE_SERVER
```

5. Log off the node.
6. Repeat the preceding steps for each node.

## Installing the Workstation License

The licenses for the Lustre workstation running Incinerator are locked to the *lmhostid* of the workstation. The workstation license file must include a license for Lustre with Incinerator as well as licenses for two plug-ins.

**NOTE:** You may require additional licenses for other Lustre optional features.

**To configure a workstation license:**

1. As root on the Lustre Media Server, log in to the workstation by typing:

```
ssh <WS_HOSTNAME>
```

where `<WS_HOSTNAME>` is the host name of the workstation you are logging in to.

You must provide the user name and password to log in to the workstation. The default password for the root user is `password`.

2. Navigate to the licenses directory by typing:

```
cd /usr/local/flexlm/licenses
```

3. Create a file called `DL_license.dat` in the directory by typing:

```
touch DL_license.dat
```

4. Open the `DL_license.dat` file in a text editor and copy and paste the feature license strings you received from the licensing department into the file. The feature license strings are similar to the following shortened example:

```
FEATURE lustre_incinerator_r_2009_L lustre <...>
```

5. Save and close the license file.

## Configuring Incinerator Daemons

There are several configuration files that control the behavior of Incinerator daemons. If you use any values different from the default (for example the IP addressing scheme), or change your Incinerator configuration after installation, you must modify these files.

### **init.config**

The `init.config` file configures communication between the Lustre workstation, the Incinerator Nodes, and the `BrowseD` daemon running on the Lustre Media Server. It is located in `/usr/autodesk/lustre_2009`.

You must fill in the value for the Port, Username, and Password keywords in the `init.config` file for Incinerator Nodes and the Lustre workstation. See [Appendix B, “Software, Project, and User Configuration Files.”](#) on page 117.

**NOTE:** If you make changes to the `init.config` file, you must restart the `BrowseD` daemon.

### **cmanagerd.conf**

The `cmanagerd.conf` file configures communication for `cmanagerd`, a daemon that allows you to view information about, and interact with, all the Incinerator system components through a single Web-based interface, the Incinerator Resource Manager. The `cmanagerd` daemon gathers information over the GigE network from all the network components and stores this information in a database that is used to populate the fields in the Resource Manager Web

interface. The *cmanagerd* daemon also sends commands to the components over the GigE network.

The *cmanagerd.conf* file indicates how the Incinerator system components communicate with *cmanagerd*, which runs on the Lustre Media Server. The *cmanagerd.conf* file is located on the Lustre Media Server in */usr/autodesk/lustre\_2009*.

The *cmanagerd.conf* file is configured with default values. If you use any configurations different from the default (like the network configuration), or change your Incinerator configuration after installation, you must modify this file.

**NOTE:** If you make changes to the *cmanagerd.conf* file, you must restart the *cmanagerd* daemon.

| Tag:                                                                                               | Contains:                                                                                                                                                                                                                                        |
|----------------------------------------------------------------------------------------------------|--------------------------------------------------------------------------------------------------------------------------------------------------------------------------------------------------------------------------------------------------|
| <pre>&lt;CMANAGERDREGISTER_INTERFACE&gt; &lt;eth0&gt; &lt;/CMANAGERDREGISTER_INTERFACE&gt;</pre>   | The network interface that is used by <i>cmanagerd</i> to connect to the database that displays information in the Resource Manager. This value should be the private Incinerator GigE network interface, which is <code>eth0</code> by default. |
| <pre>&lt;CMANAGERDBROADCAST_INTERFACE&gt; &lt;eth0&gt; &lt;/CMANAGERDBROADCAST_INTERFACE&gt;</pre> | The network interface that <i>cmanagerd</i> listens to for information broadcast by the system components. This value should be the private Incinerator GigE network interface, which is <code>eth0</code> by default.                           |
| <pre>&lt;DATABASE_ADDRESS&gt; &lt;localhost&gt;&lt;/DATABASE_ADDRESS&gt;</pre>                     | The location of the database that stores information about the system components. This value is the IP address of the Lustre Media Server, which is <code>localhost</code> by default.                                                           |

## **cmanagerdclient.conf**

The *cmanagerdclient.conf* file enables Incinerator system components to communicate with *cmanagerd* running on the Lustre Media Server. This file is located on all Incinerator system components in */usr/autodesk/lustre\_2009*.

This file is configured with default values. If you use any values different from the default (for example the network configuration), or change your Incinerator configuration after installation, you must modify this file.

**NOTE:** If you make changes to the *cmanagerdclient.conf* file on the workstation, you must restart Lustre on the workstation. If you make changes to the *cmanagerdclient.conf* file on an Incinerator Node, then you must manually restart *renderd* on the node. If you make changes to

*cmanagerdclient.conf* on the Lustre Media Server, then you must manually restart *BrowseD* and *cmanagerd* on the Lustre Media Server.

| Tag:                                                                                         | Contains:                                                                                                                                                                                                               |
|----------------------------------------------------------------------------------------------|-------------------------------------------------------------------------------------------------------------------------------------------------------------------------------------------------------------------------|
| <pre>&lt;CMANAGERDCLIENT_INTERFACE&gt; &lt;eth0&gt; &lt;/CMANAGERDCLIENT_INTERFACE&gt;</pre> | The network interface that is used by the component to send information to <i>cmanagerd</i> running on the Lustre Media Server. This value should be the GigE network interface, which is <code>eth0</code> by default. |
| <pre>&lt;CMANAGERD_ADDRESS&gt; &lt;10.10.10.1&gt; &lt;/CMANAGERD_ADDRESS&gt;</pre>           | The GigE IP address of the component that is running <i>cmanagerd</i> , which is the Lustre Media Server. This value is <code>10.10.10.1</code> by default.                                                             |

## Using Lustre with Incinerator

After you have licensed and configured all of the components on your system, you are ready to begin using Lustre with Incinerator for real-time playback of your 2K 10-bit frames.

See the following table for the recommended steps for using Lustre with Incinerator.

| Step:                                      | Refer to:                                                                          |
|--------------------------------------------|------------------------------------------------------------------------------------|
| 1. Start Lustre.                           | <a href="#">“Starting Lustre on the Workstation”</a> on page 62.                   |
| 2. Set up your project to use Incinerator. | <a href="#">“Setting Up Lustre Project Management for Incinerator”</a> on page 63. |
| 3. Play back your shots.                   | <a href="#">“Using Incinerator for Real-Time Playback”</a> on page 63.             |

## Starting Lustre on the Workstation

There are two methods you can use to start Lustre on the workstation.

**NOTE:** When logging on the workstation to use Lustre, use the Lustre-specific user.

### To start Lustre on the workstation:

- Start the application by doing one of the following:
  - Double-click the Lustre desktop icon.
  - Open a shell and navigate to the Lustre directory. Type:

```
cd /usr/autodesk/lustre_2009/
```

Next, start Lustre. Type:

**./lustre**

The application launches and the interface appears.

## Setting Up Lustre Project Management for Incinerator

This section provides an overview of setting up projects in Lustre with Incinerator. For detailed information on how to create a project, consult the *Autodesk Lustre 2009 User Guide*.

To use Incinerator on the Lustre workstation, at least the *Scans Full Home* path must point to the private Gigabit Ethernet (GigE) IP address of the Lustre Media Server.

Depending on your data management scheme, you can point the other project directories to the Lustre Media Server. Only the Scans Full Home must point to the Lustre Media Server for Incinerator.

The following project setup example illustrates how to append the GigE IP address of the Lustre Media Server to all your project paths.

|                   |                                    |
|-------------------|------------------------------------|
| Project Home      | /mnt/md0/Projects                  |
| Scans Full Home   | 10.10.11.1:/mnt/md0/scans          |
| Scans Half Home   | 10.10.11.1:/mnt/md0/scans_half     |
| Renders Full Home | 10.10.11.1:/mnt/md0/renderers      |
| Renders Half Home | 10.10.11.1:/mnt/md0/renderers_half |

## Using Incinerator for Real-Time Playback

To use Incinerator for real-time playback, you must connect to a group of Incinerator Nodes from Lustre and then enable real-time playback.

See the following table for the tasks you must complete to use Incinerator for real-time playback in Lustre.

| Step:                                                                      | Refer to:                                                                  |
|----------------------------------------------------------------------------|----------------------------------------------------------------------------|
| 1. Create groups of Incinerator Nodes in the Incinerator Resource Manager. | <a href="#">"Creating Incinerator Node Groups"</a> on page 76.             |
| 2. Open the Cluster menu.                                                  | <a href="#">"Accessing the Cluster Menu"</a> on page 64.                   |
| 3. Connect to a group of Incinerator Nodes.                                | <a href="#">"Connecting to Incinerator Node Groups"</a> on page 64.        |
| 4. Enable real-time playback with Incinerator.                             | <a href="#">"Enabling Real-Time Playback with Incinerator"</a> on page 65. |
| 5. Add grades and effects, and play back your shots.                       | <i>Autodesk Lustre 2009 User Guide</i>                                     |

## Accessing the Cluster Menu

To connect to a group of Incinerator Nodes, you must access the Cluster menu in Lustre.

### To access the Cluster menu:

- In the Main menu, click Render.

The Cluster menu appears.

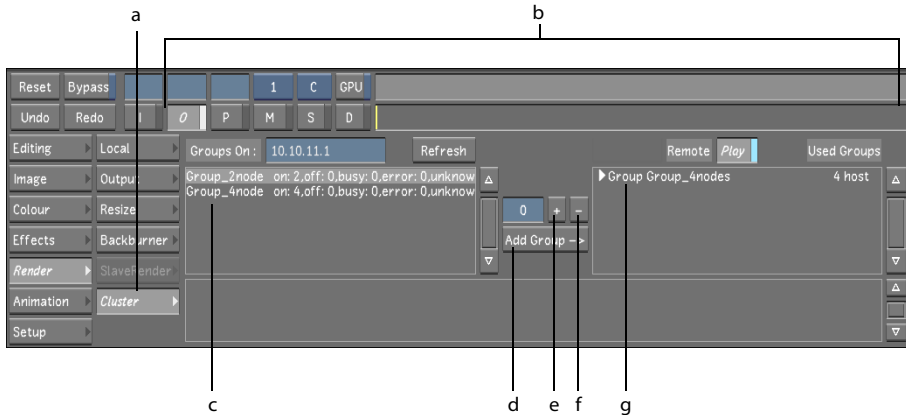

- a) Cluster button
- b) Cluster menu
- c) List of Incinerator Node groups
- d) Add (Remove) Group button
- e) Add Incinerator Node button
- f) Remove Incinerator Node button
- g) List of Incinerator Node groups loaded in project

## Connecting to Incinerator Node Groups

To use Incinerator for real-time playback, you must connect to a group of Incinerator Nodes from the Cluster menu.

Before you can load Incinerator Node groups in the Lustre application, you must create them in the Incinerator Resource Manager. See [“Creating Incinerator Node Groups”](#) on page 76 for information about creating Incinerator Node groups.

### To start Lustre and Incinerator on the workstation:

1. In the main menu, click Render, and then click Cluster.

The Cluster menu appears.

- From the list of Incinerator Node groups, select a group of nodes to use for this project.

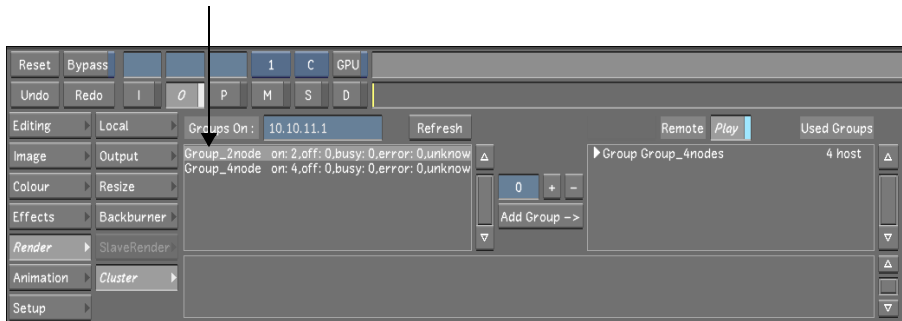

By default, all nodes in the group are available to the project.

**NOTE:** If you create additional groups using the Incinerator Resource Manager while Lustre is open, you must click Refresh for those groups to appear in the list and be available for use.

- Optional: Select the number of nodes in the group that you want to use by clicking the Add Incinerator Node button. You can also type a number in the field to the left of the Add Incinerator Node button. You can remove nodes by clicking the Remove Node button.
  - Click Add Group.
- This moves the selected group to the list of groups loaded in the project to the right.
- From the list of Incinerator Node groups loaded in the project, select the Incinerator Node group to be used during the session and click Reconnect.

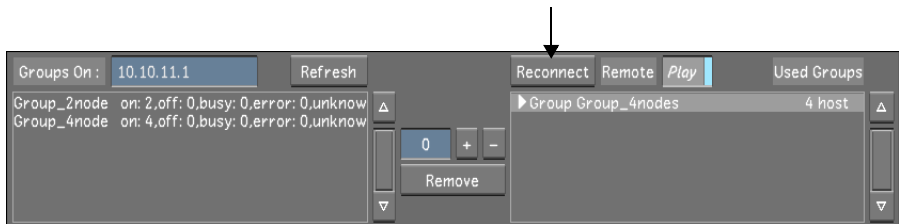

The Lustre application connects to and takes control of the Incinerator Nodes in the group. When you restart the application, Lustre reconnects to the group of Incinerator Nodes you last used.

### Enabling Real-Time Playback with Incinerator

To play back frames in real-time using Incinerator, you must enable the Play button. The Play button is enabled by default.

**To enable real-time playback with Incinerator:**

1. In the main menu, click Render, and then click Cluster.  
The Cluster menu appears.
2. Click the Play button to enable real-time play back of rendered frames using Incinerator.

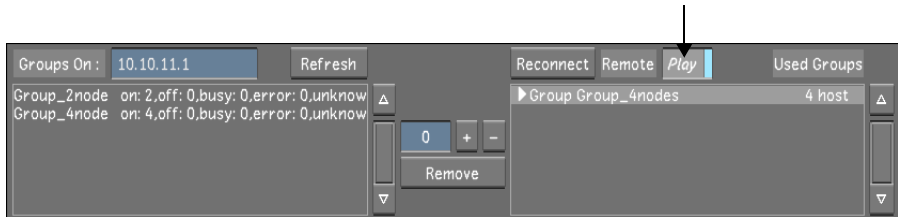

3. Begin using Lustre to create colour grades and effects.
4. Play back your shot. For instructions, see the “Playing, Viewing and Sorting Shots” chapter in the *Autodesk Lustre 2009 User Guide*.  
The Incinerator Nodes in the group process the grades and effects for real-time playback.



# Using the Incinerator Resource Manager

## Summary

|                                                                                        |    |
|----------------------------------------------------------------------------------------|----|
| <a href="#">About the Incinerator Resource Manager</a> .....                           | 67 |
| <a href="#">Starting the Resource Manager</a> .....                                    | 68 |
| <a href="#">Monitoring the Status of System Components</a> .....                       | 70 |
| <a href="#">Managing Incinerator Node Groups</a> .....                                 | 75 |
| <a href="#">Stopping and Starting Incinerator Daemons</a> .....                        | 86 |
| <a href="#">Deleting Duplicate Lustre Media Servers, Workstations, and Nodes</a> ..... | 89 |
| <a href="#">Managing Resource Manager User Accounts</a> .....                          | 90 |

## About the Incinerator Resource Manager

You can use the Incinerator Resource Manager to monitor and manage system components, including:

- The Lustre application running on the Lustre workstation.
- The *BrowseD* daemon running on the Lustre Media Server. The *BrowseD* daemon provides the path to all frames on the storage. This daemon may also run on the Lustre workstation.
- The *renderd* daemon running on the Incinerator Nodes. The *renderd* daemon renders frames for display on the Lustre workstation.

All users can use the Incinerator Resource Manager to view the status of Incinerator system components. However, the ability to manage user accounts, administrator permissions, groups and nodes, and start/stop Incinerator daemons can be limited to selected users and administrators.

See [“Managing Permissions”](#) on page 94 for information about tasks that can be limited to selected users.

**NOTE:** User accounts and permissions for the Incinerator Resource Manager are different from Linux user accounts. You create and manage Resource Manager user accounts in the Resource Manager.

## Starting the Resource Manager

Start the Incinerator Resource Manager to monitor and manage the Incinerator system.

You can display the Resource Manager on any workstation with access to the Incinerator network and a Web browser.

### To start the Incinerator Resource Manager:

1. Open a Web browser on a workstation with access to the Incinerator network.
2. Type the following in the address bar:

**http://<frameserver>/incinerator**

where <frameserver> is the Gigabit Ethernet (GigE) IP address of your Lustre Media Server. For example, if your Lustre Media Server uses the default GigE IP address of 10.10.10.1, you would enter the following in the address bar of the Web browser:

**http://10.10.10.1/incinerator**

**HINT:** Create a bookmark in your Web browser for the Resource Manager.

The Resource Manager appears in the browser.

The screenshot displays the Incinerator Resource Manager web interface. The interface is divided into several sections:

- Navigation:** Tabs for Groups, Nodes, Workstations, Renders, Servers, and Settings. A Refresh List button is in the top right.
- Group Summary:** Shows 'group' with Owner: admin, Date Created: 2005-09-09 11:49:13, Number of Servers: 8, and Status: ready:8.
- Servers Table:** A table listing 8 servers (node01 to node08) with columns for Server Name, Ip address, State, and Last Message. All servers are in a 'ready' state.
- Incinerator Summary:** Shows 'Incinerator' with Owner: admin, Date Created: 2005-09-09 12:15:53, Number of Servers: 8, and Status: ready:8.
- Servers Table:** A second table listing 8 servers (node01 to node08) with columns for Server Name, Ip address, State, and Last Message. All servers are in a 'ready' state.
- Right Panel:** Contains 'View style' (Short/Long), 'Group shortcuts' (group, Incinerator, All), and 'Manager status: Online' with a 'User: Anonymous' and a 'Login' button.

## Logging In and Logging Out of the Incinerator Resource Manager

When you start the Incinerator Resource Manager, you are logged in as the anonymous user. This user and all other users can view the status of all the components of the Incinerator system.

To create users, stop/start Incinerator daemons, administer nodes and node groups, and change permissions, you may have to log in to the Resource Manager with a user account that has permission to perform the required tasks. See [“Managing Permissions”](#) on page 94 for information about tasks that may require specific permissions.

The first time you log in, you can use the default administrator account. We recommend that you change the default administrator account to use a secure password of your choosing. See [“Modifying a User Account Password”](#) on page 91.

### To log in to the Incinerator Resource Manager:

1. Start the Incinerator Resource Manager. See [“Starting the Resource Manager”](#) on page 68.
2. In the right column of the Incinerator Resource Manager Web page, click Login.

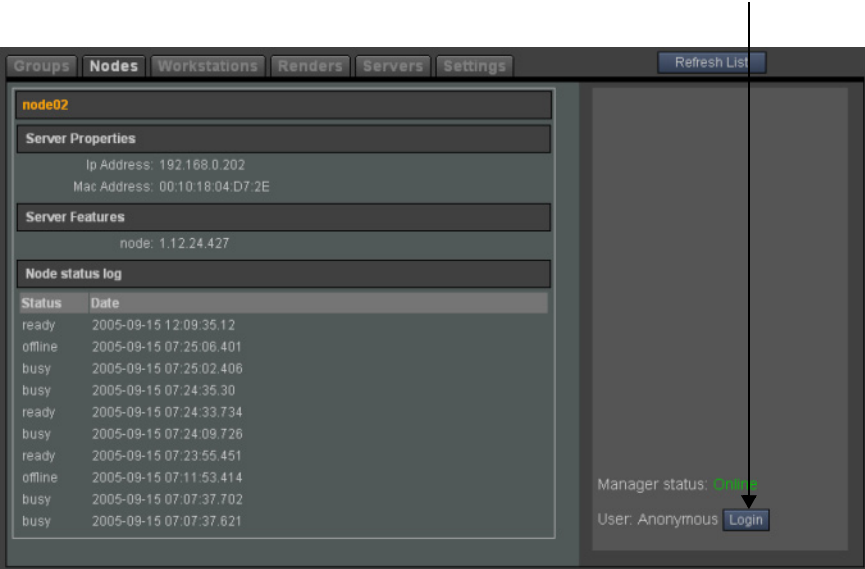

The User authentication panel opens in the right column of the Resource Manager.

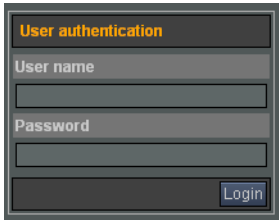

3. Type your Resource Manager user name and password in the User name and password fields.

The default administrator account user name is **admin** and its default password is **admin**.

**NOTE:** Values for the user name and password are case-sensitive.

4. Click Login.

After you log in, the name of the current user appears in the lower-right corner of the Resource Manager.

**To log out of the Incinerator Resource Manager:**

- In the lower-right corner of the Resource Manager, click Logout.

## Monitoring the Status of System Components

All users can use the Incinerator Resource Manager to monitor the status of Incinerator system components.

### Monitoring the Status of Incinerator Nodes

You can view the status and details for all Incinerator Nodes on the Incinerator system.

All Incinerator Nodes run the *renderd* daemon to process frames for real-time playback on the Lustre workstation. When you view the status of nodes, you see the status of the *renderd* daemon running on those nodes.

**To view the status of Incinerator Nodes on the Incinerator system:**

1. Start the Incinerator Resource Manager. See [“Starting the Resource Manager”](#) on page 68.
2. Click Nodes.

A list of all Incinerator Nodes on the Incinerator system appear in the Resource Manager.

| Name   | Status | Ip address    | Mac address       | Groups            |
|--------|--------|---------------|-------------------|-------------------|
| node02 | ready  | 192.168.0.202 | 00:10:18:04:D7:2E | group,Incinerator |
| node03 | ready  | 192.168.0.203 | 00:10:18:09:FF:AA | group,Incinerator |
| node04 | ready  | 192.168.0.204 | 00:10:18:04:D4:42 | group,Incinerator |
| node05 | ready  | 192.168.0.205 | 00:10:18:04:D4:E6 | group,Incinerator |
| node06 | ready  | 192.168.0.206 | 00:10:18:04:D6:4E | group,Incinerator |
| node01 | ready  | 192.168.0.201 | 00:10:18:04:D7:1C | group,Incinerator |
| node08 | ready  | 192.168.0.208 | 00:10:18:04:D9:9B | group,Incinerator |
| node07 | ready  | 192.168.0.207 | 00:10:18:04:D4:6C | group,Incinerator |

Manager status: Online  
User: Anonymous

The Node list shows the following information for each Incinerator Node:

- The name of the Incinerator Node.
  - The current status of the *renderd* daemon running on the Incinerator Node
  - The IP and MAC addresses of the Incinerator Node.
  - The groups to which the Incinerator Node belongs.
3. Click a node in the list to view its details.

Details for the selected Incinerator Node appear in the Resource Manager, including a log showing recent status messages.

| Status  | Date                    |
|---------|-------------------------|
| ready   | 2005-09-15 12:09:35.12  |
| offline | 2005-09-15 07:25:06.401 |
| busy    | 2005-09-15 07:25:02.406 |
| busy    | 2005-09-15 07:24:35.30  |
| ready   | 2005-09-15 07:24:33.734 |
| busy    | 2005-09-15 07:24:09.726 |
| ready   | 2005-09-15 07:23:55.451 |
| offline | 2005-09-15 07:11:53.414 |
| busy    | 2005-09-15 07:07:37.702 |
| busy    | 2005-09-15 07:07:37.621 |

Manager status: Online  
User: Anonymous

**HINT:** You also use this panel to stop or restart the *renderd* daemon on an Incinerator Node. See [“Stopping and Starting Incinerator Daemons”](#) on page 86.

4. Click Nodes to return to the list.

## Monitoring the Status of the Lustre Media Server

You can view the status and details for all Lustre Media Servers on the Incinerator system.

All Lustre Media Servers run the *BrowseD* daemon to provide access to frames from the storage attached to it. When you view the status of servers, you see the status of the *BrowseD* daemon running on the server.

The *BrowseD* daemon can also run on the workstation for background rendering. If the workstation is running *BrowseD*, it will also appear on the Servers tab of the Incinerator Resource Manager.

### To view the status of Lustre Media Servers on the Incinerator system:

1. Start the Incinerator Resource Manager. See [“Starting the Resource Manager”](#) on page 68.
2. Click Servers.

A list of all Lustre Media Servers on the Incinerator system appear in the Resource Manager.

| Name        | Status | Ip address    | Mac address       |
|-------------|--------|---------------|-------------------|
| workstation | ready  | 192.168.0.200 | 00:0D:60:16:CF:14 |
| server      | ready  | 192.168.0.199 | 00:11:25:8C:78:78 |

Manager status: Online  
 User: Anonymous

The Server list shows the following information for each Lustre Media Server:

- The name of the Lustre Media Server.
  - The current status of the *BrowseD* daemon running on the Lustre Media Server.
  - The IP and MAC addresses of the Lustre Media Server.
3. Click a Lustre Media Server in the list to view its details.

Details for the selected Lustre Media Server appear in the Resource Manager, including a log showing recent status messages.

The screenshot shows the Incinerator Resource Manager interface. The 'Servers' tab is selected, displaying details for a server named 'server'. The interface includes a 'Refresh List' button in the top right. The main content area is divided into sections: 'Server Properties' (Ip Address: 192.168.0.199, Mac Address: 00:11:25:8C:78:78), 'Server Features' (bd: 2,12,27,1914), and 'Server status log'. The log table shows a sequence of 'ready' and 'offline' status changes with corresponding timestamps. On the right side, the 'Manager status' is 'Online' and the user is 'Anonymous' with a 'Login' button.

| Status  | Date                    |
|---------|-------------------------|
| ready   | 2005-09-14 06:51:11.724 |
| offline | 2005-09-14 06:49:58.861 |
| ready   | 2005-09-12 10:09:20.793 |
| offline | 2005-09-12 10:08:03.531 |
| ready   | 2005-09-12 08:43:17.613 |
| offline | 2005-09-12 08:42:33.178 |
| ready   | 2005-09-12 08:42:08.719 |
| offline | 2005-09-12 08:34:18.621 |
| ready   | 2005-09-12 08:34:10.655 |
| offline | 2005-09-12 08:31:08.691 |

**HINT:** You can also use this panel to stop or restart the *BrowseD* daemon on the Lustre Media Server. See [“Stopping and Starting Incinerator Daemons”](#) on page 86.

4. Click Servers to return to the list.

## Monitoring the Status of the Lustre Workstation

You can view the status and details for all Lustre workstations on the Incinerator system.

The Workstation status in the Incinerator Resource Manager indicates the status of the Lustre application on that workstation. It does not indicate the overall status of the workstation.

**To view the status of Lustre workstations on the Incinerator system:**

1. Start the Incinerator Resource Manager. See [“Starting the Resource Manager”](#) on page 68.
2. Click Workstations.

A list of all Lustre workstations on the Incinerator system appears in the Resource Manager.

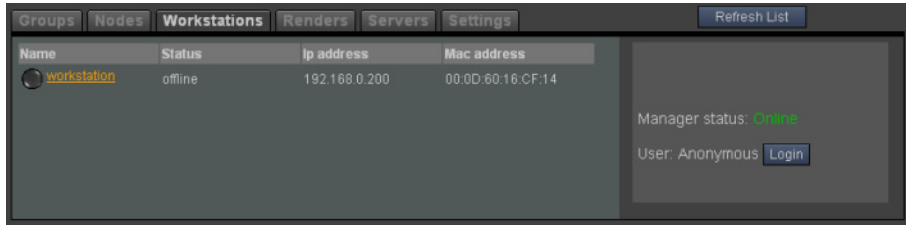

The Workstation list shows the following information for each workstation running Lustre:

- The name of the workstation.
  - The status of the Lustre application (running or offline).
  - The IP and MAC addresses for the workstation.
3. Click a workstation from the list to view its details.

Details for the selected Lustre workstation appear in the Resource Manager.

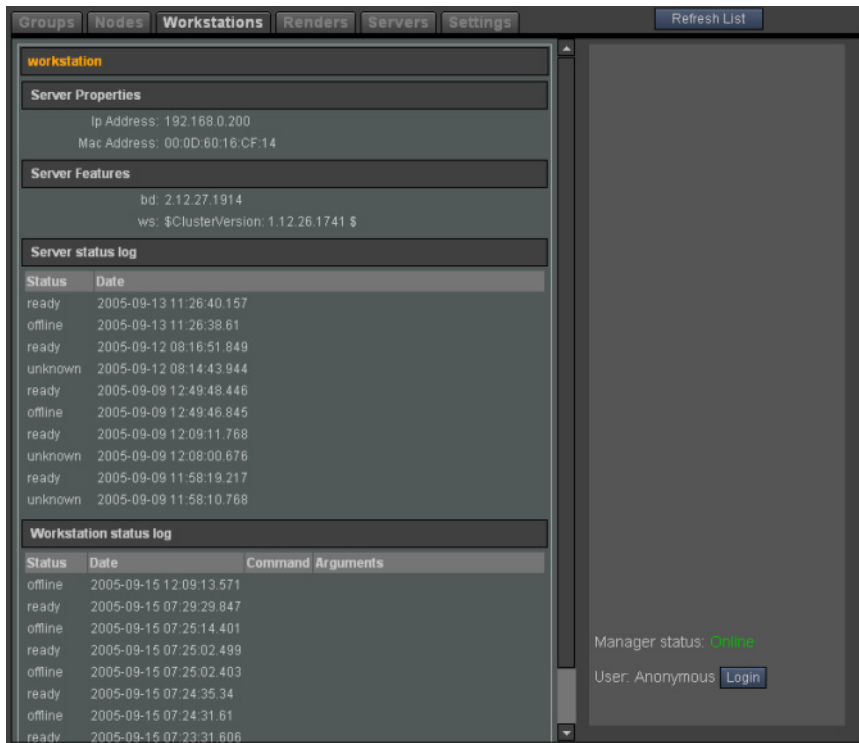

4. Click Workstations to return to the list.

## Monitoring Command-Line Rendering on the Incinerator System

The Renders tab on the Incinerator Resource Manager identifies Incinerator system components that are currently running the command-line renderer.

With the command-line renderer, you can render final frames using the Incinerator Nodes. The command-line renderer manages the process and writes the rendered frames to the file system.

### To view the status of command-line rendering on the Incinerator system:

1. Start the Incinerator Resource Manager. See [“Starting the Resource Manager”](#) on page 68.
2. Click Renders.

Machines running the command-line renderer appear in the Resource Manager with the Status set to “busy”.

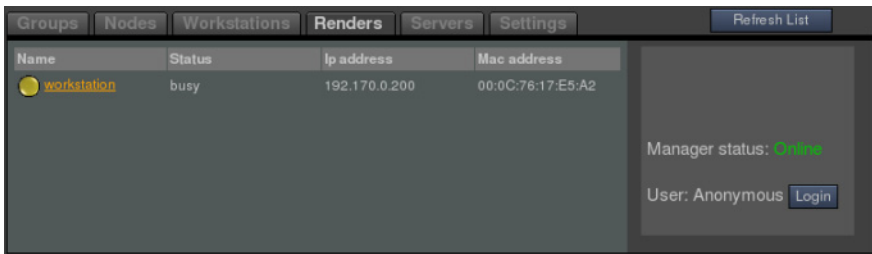

## Managing Incinerator Node Groups

From the Resource Manager, you can organize nodes into groups. Grouping nodes makes it easier to manage the nodes.

Use the following table to locate the Incinerator Node task you want to perform.

| To:                                                                | See:                                                                                    |
|--------------------------------------------------------------------|-----------------------------------------------------------------------------------------|
| Create a new Incinerator Node group.                               | <a href="#">“Creating Incinerator Node Groups”</a> on page 76.                          |
| Change the name or owner of an Incinerator Node group.             | <a href="#">“Modifying the Name or Owner of an Incinerator Node Group”</a> on page 80.  |
| Add Incinerator Nodes to or remove Incinerator Nodes from a group. | <a href="#">“Modifying the Nodes Assigned to an Incinerator Node Group”</a> on page 82. |

| To:                                                                                 | See:                                                                    |
|-------------------------------------------------------------------------------------|-------------------------------------------------------------------------|
| Delete a group.                                                                     | <a href="#">“Deleting Incinerator Node Groups”</a> on page 85.          |
| Start or stop the <i>renderd</i> daemon running on a single node or group of nodes. | <a href="#">“Stopping and Starting Incinerator Daemons”</a> on page 86. |

## Creating Incinerator Node Groups

You must create an Incinerator Node group with the Resource Manager to run Incinerator on the Lustre workstation. You can also use Incinerator Node groups to quickly stop or restart multiple nodes for maintenance.

To create an Incinerator Node group, you first create the group and then add nodes to it.

In order to create Incinerator Node groups, you may require permissions to administer groups and nodes. See [“Managing Permissions”](#) on page 94.

### To create an Incinerator Node group:

1. If necessary, log in to the Resource Manager with a user account that has rights to administer groups and nodes. See [“Logging In and Logging Out of the Incinerator Resource Manager”](#) on page 69.
2. Click Groups.

A list of groups on the Incinerator system appears. You create new groups using the Create New Server Group area in the Resource Manager.

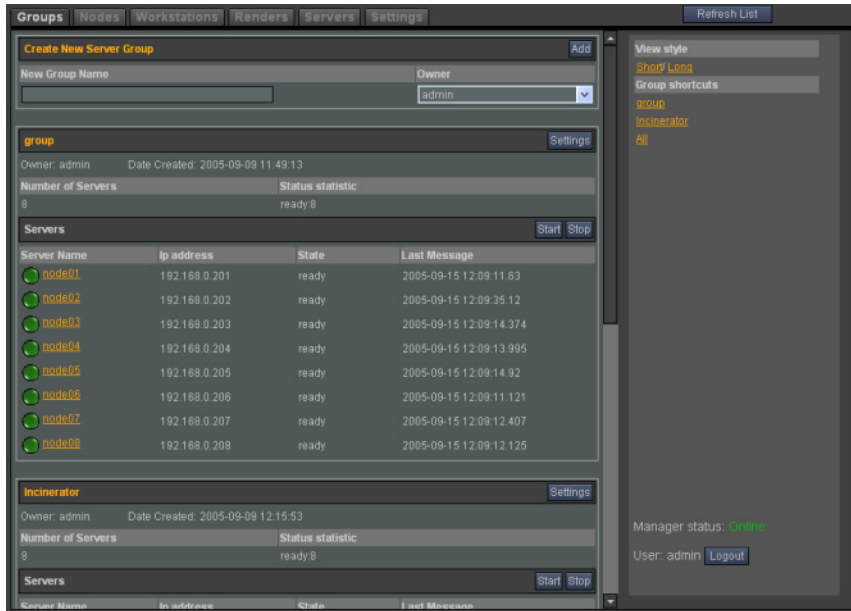

**HINT:** To view a summary of all Incinerator Node groups on the Incinerator system, go to View Style at the right of the Resource Manager and click Short.

3. Enter the name of the new Incinerator Node group in the New Group Name field.
4. Optional: Enter the name of the user who administers the group in the Owner field. Rights to administer groups are not limited to the group owner. Setting an owner does not restrict the rights of other users for that group. The value just indicates ownership.
5. Click Add.

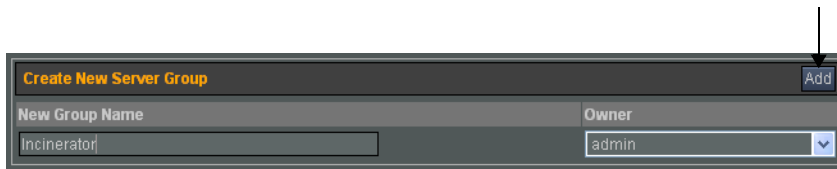

The Incinerator Node group is created and appears in the following location:

- The main list of all Incinerator Node groups.
- The Group Shortcuts area at the right of the Incinerator Resource Manager.

**HINT:** To quickly scroll to a Incinerator Node group, click the group's name in the Group Shortcuts area.

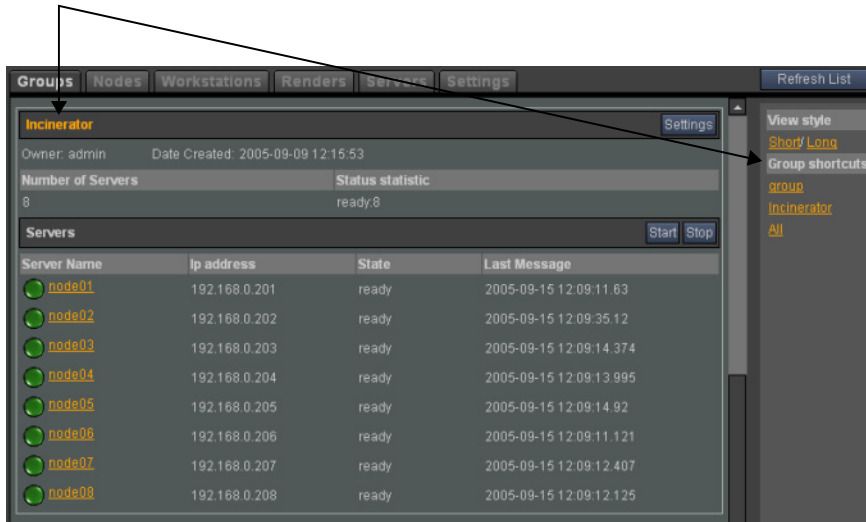

By default, new Incinerator Node groups have no nodes assigned to them. Next, add Incinerator Nodes to the new group.

6. Click Settings beside the group's name.

The Resource Manager displays the name, owner, and Incinerator Nodes assigned to the group (if any). Incinerator Nodes on the system are organized in the following three lists.

| List             | Contents                                                                     |
|------------------|------------------------------------------------------------------------------|
| All Nodes        | Shows all nodes on the Incinerator system.                                   |
| Unassigned Nodes | Shows nodes not currently assigned to a group.                               |
| Nodes in Group   | Shows nodes assigned to the current group. This list is empty for new groups |

7. From the Unassigned Nodes list, select the Incinerator Nodes for the new group, and then click Add.

The Incinerator Nodes are added to the new group. In the example below, all eight nodes are added to the group.

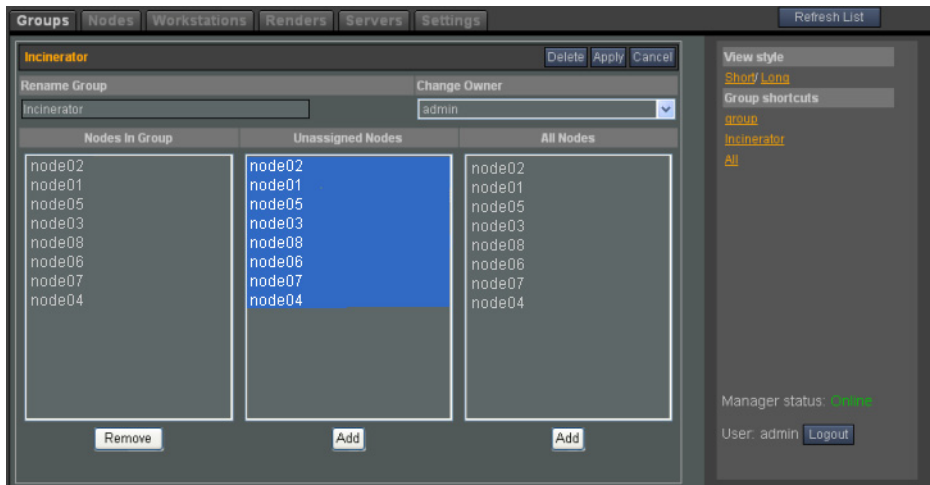

**NOTE:** You can also add Incinerator Nodes from the All Nodes list to the current group. However, adding the same Incinerator Node to multiple groups is not recommended.

8. Click Apply.

The assigned Incinerator Nodes appear with the group in the list.

The screenshot shows the 'Groups' tab in the Incinerator Resource Manager. At the top, there is a 'Create New Server Group' section with a text input for 'New Group Name' and a dropdown for 'Owner' (set to 'admin'). Below this is the 'Incinerator' group details, including 'Owner: admin' and 'Date Created: 2005-09-20 05:20:49'. A summary row shows 'Number of Servers: 8' and 'Status statistic: ready:8'. The main section is a table of servers with columns for 'Server Name', 'Ip address', 'State', and 'Last Message'.

| Server Name | Ip address    | State | Last Message            |
|-------------|---------------|-------|-------------------------|
| node01      | 192.168.0.201 | ready | 2005-09-19 12:14:01.747 |
| node02      | 192.168.0.202 | ready | 2005-09-19 12:14:00.225 |
| node03      | 192.168.0.203 | ready | 2005-09-19 12:14:00.48  |
| node04      | 192.168.0.204 | ready | 2005-09-19 12:14:00.796 |
| node05      | 192.168.0.205 | ready | 2005-09-19 12:14:01.113 |
| node06      | 192.168.0.206 | ready | 2005-09-19 12:14:01.469 |
| node07      | 192.168.0.207 | ready | 2005-09-19 12:14:02.362 |
| node08      | 192.168.0.208 | ready | 2005-09-19 12:14:02.56  |

**HINT:** Click Refresh List if the group does not appear to change.

## Modifying the Name or Owner of an Incinerator Node Group

Modify the name or owner of an Incinerator Node using the following procedure.

Changing the owner of a group does not restrict the rights of other users for that group. The value just indicates ownership.

In order to modify the name or owner of an Incinerator Node group, you may require permissions to administer groups and nodes. See [“Managing Permissions”](#) on page 94.

### To modify the name or owner of an Incinerator Node group:

1. If necessary, log in to the Resource Manager with a user account that has rights to administer groups and nodes. See [“Logging In and Logging Out of the Incinerator Resource Manager”](#) on page 69.
2. Click Groups.  
A list of all Incinerator Node groups on the Incinerator system appears.

3. Locate the group to be modified by doing one of the following:
  - Scroll through the list of all Incinerator Node groups.
  - Click the name of the Incinerator Node group in the Group Shortcuts area at the right side of the Resource Manager.
4. Click Settings.

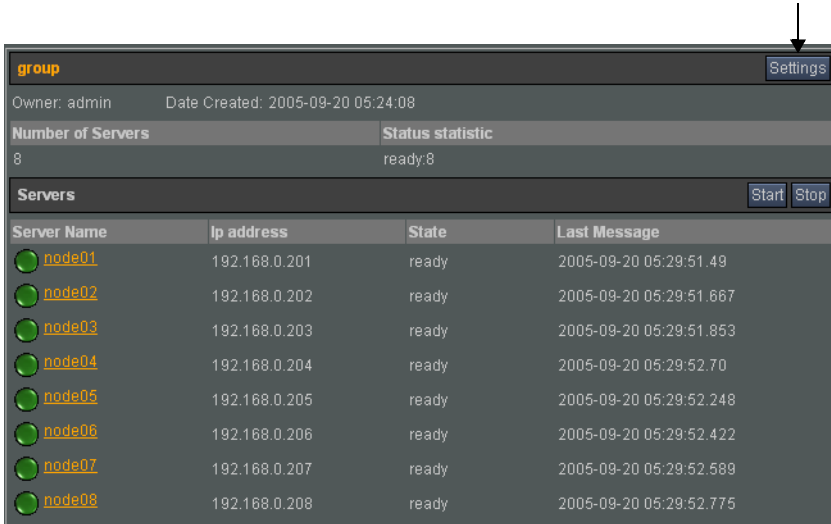

The Resource Manager displays the name, owner, and Incinerator Nodes assigned to the group. Use these controls to modify the group's name or owner, as well as the Incinerator Nodes assigned to the group.

5. In the Change Group Name field, enter a new name for the group.
6. From the Change Owner list, choose a new group owner.
7. Click Apply.

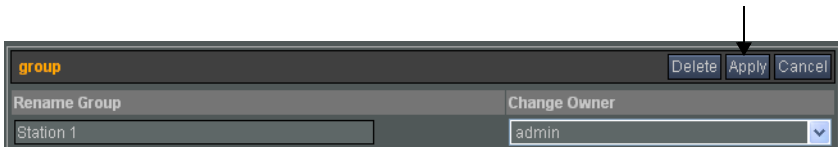

The group's name or owner is updated.

| Server Name | Ip address    | State | Last Message            |
|-------------|---------------|-------|-------------------------|
| node01      | 192.168.0.201 | ready | 2005-09-20 05:29:51.49  |
| node02      | 192.168.0.202 | ready | 2005-09-20 05:29:51.667 |
| node03      | 192.168.0.203 | ready | 2005-09-20 05:29:51.853 |
| node04      | 192.168.0.204 | ready | 2005-09-20 05:29:52.70  |
| node05      | 192.168.0.205 | ready | 2005-09-20 05:29:52.248 |
| node06      | 192.168.0.206 | ready | 2005-09-20 05:29:52.422 |
| node07      | 192.168.0.207 | ready | 2005-09-20 05:29:52.589 |
| node08      | 192.168.0.208 | ready | 2005-09-20 05:29:52.775 |

## Modifying the Nodes Assigned to an Incinerator Node Group

Add Incinerator Nodes to, or remove Incinerator Nodes from, a group using the following procedure.

In order to modify the nodes assigned to an Incinerator Node group, you may require permission to administer groups and nodes. See [“Managing Permissions”](#) on page 94.

### To modify the nodes assigned to an Incinerator Node group:

1. If necessary, log in to the Resource Manager with a user account that has rights to administer groups and nodes. See [“Logging In and Logging Out of the Incinerator Resource Manager”](#) on page 69.
2. Click Groups.  
A list of all Incinerator Node groups on the Incinerator system appears.
3. Locate the group to be modified by doing one of the following:
  - Scroll through the list of all Incinerator Node groups.
  - Click the name of the Incinerator Node group in the Group Shortcuts area at the right side of the Incinerator Resource Manager.

4. Click Settings.

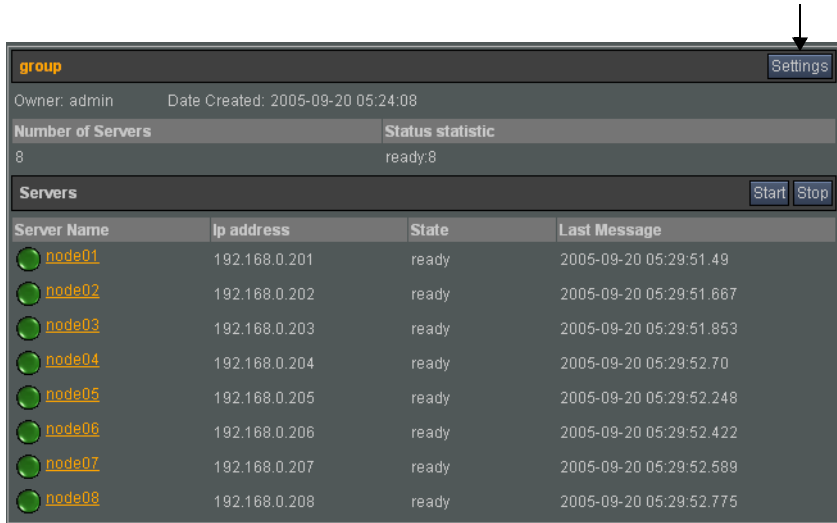

The Resource Manager displays the name, owner, and Incinerator Nodes assigned to the group. Use these controls to modify the Incinerator Nodes assigned to the group, as well as modify the group's name or owner.



5. Modify the Incinerator Nodes in the group by doing either of the following:

- To add Incinerator Nodes to the group, select the Incinerator Nodes from the Unassigned Nodes list and click Add.
- To remove Incinerator Nodes from the group, select the Incinerator Nodes from the Nodes In Group list and click Remove.

The list of Incinerator Nodes in the group is updated. In the example below, node 05, 06, 07, and 08 are removed from the group.

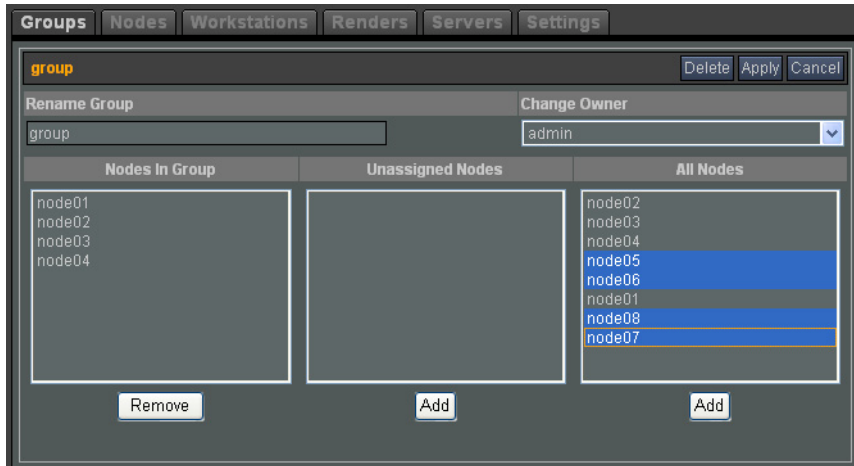

**NOTE:** You can also add Incinerator Nodes from the All Nodes list to the current group. However, adding the same Incinerator Node to multiple groups is not recommended.

6. Click Apply.

The Incinerator Node group is updated in the Resource Manager.

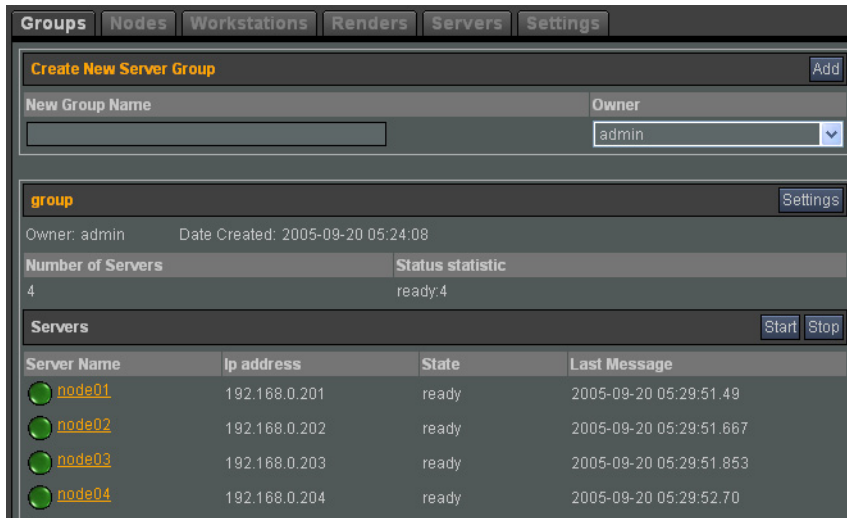

## Deleting Incinerator Node Groups

Use the Incinerator Resource Manager to delete an Incinerator Node group when it is not needed anymore. When you delete an Incinerator Node group, its Incinerator Nodes can be assigned to other groups through the Resource Manager.

In order to delete Incinerator Node groups, you may require permission to administer groups and nodes. See [“Managing Permissions”](#) on page 94.

### To delete an Incinerator Node group:

1. If necessary, log in to the Resource Manager with a user account that has rights to administer groups and nodes. See [“Logging In and Logging Out of the Incinerator Resource Manager”](#) on page 69.
2. Click Groups.  
A list of all Incinerator Node groups on the Incinerator system appears.
3. Locate the group to be modified by doing one of the following:
  - Scroll through the list of all Incinerator Node groups.
  - Click the name of the Incinerator Node group in the Group Shortcuts area at the right side of the Incinerator Resource Manager.
4. Click Settings.

The screenshot shows the 'test group' settings page in the Incinerator Resource Manager. The page has a dark theme and includes a navigation bar at the top with tabs for Groups, Nodes, Workstations, Renders, Servers, and Settings. The 'test group' details are shown, including the owner (admin) and date created (2005-09-20 05:46:35). A 'Settings' button is located in the top right corner of the group details area, indicated by a black arrow. Below the group details, there is a table showing the status of four servers (node02, node03, node04, node05) with columns for Server Name, IP address, State, and Last Message.

| Server Name | IP address    | State | Last Message            |
|-------------|---------------|-------|-------------------------|
| node02      | 192.168.0.202 | ready | 2005-09-20 05:29:51.667 |
| node03      | 192.168.0.203 | ready | 2005-09-20 05:29:51.853 |
| node04      | 192.168.0.204 | ready | 2005-09-20 05:29:52.70  |
| node05      | 192.168.0.205 | ready | 2005-09-20 05:29:52.248 |

- Click Delete.

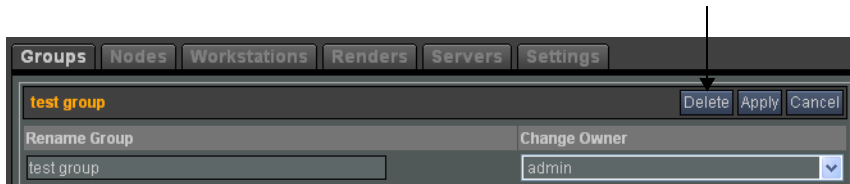

You are prompted to confirm the group's deletion.

- Click OK to delete the group.

The Incinerator Node group is deleted and the list of Incinerator Node groups reappears in the Resource Manager.

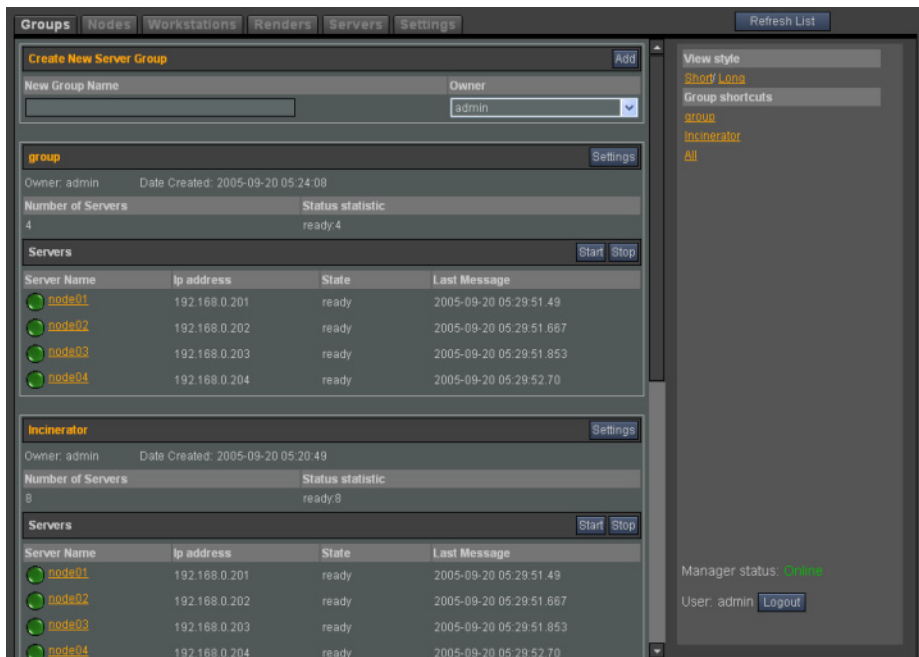

Any Incinerator Nodes that were used exclusively by the group are freed for reassignment. To reassign these Incinerator Nodes, see [“Modifying the Nodes Assigned to an Incinerator Node Group”](#) on page 82.

## Stopping and Starting Incinerator Daemons

You can stop and restart Incinerator daemons on all system components using the Resource Manager.

You may require permission to stop and start the Incinerator daemons. See [“Managing Permissions”](#) on page 94.

- When you stop or start an Incinerator Node group, you stop or start the *renderd* daemon all nodes in the group. This has the same effect as logging in to each Incinerator Node in the group and running the */etc/init.d/renderd\_2009 stop* or */etc/init.d/renderd\_2009 start* commands.
- When you stop a node, you stop the *renderd* daemon on that node. This has the same effect as logging in to an Incinerator Node and running the */etc/init.d/renderd\_2009 stop* or */etc/init.d/renderd\_2009 start* commands.
- When you stop or start a server, you stop or start the *BrowseD* daemon on the Lustre Media Server or workstation. This has the same effect as logging in to a Lustre Media Server and running the */etc/init.d/browsed\_2009 stop* or */etc/init.d/browsed\_2009 start* commands.

**NOTE:** To be able to start or stop a daemon on any machine, the daemon must have the *chkconfig* flag set to on.

 **WARNING:** Stopping daemons halts all operations without completing or saving. Be sure that the Lustre application and daemons are idle and all work has been saved before you stop them. Failure to do so may cause loss of work.

**To stop and restart Incinerator daemons from the Resource Manager:**

1. If necessary, log in to the Resource Manager with a user account that has permission to start and stop daemons. See [“Logging In and Logging Out of the Incinerator Resource Manager”](#) on page 69.
2. Click the tab that controls the daemons you want to stop or start.

| Select: | To:                                                                                                                   |
|---------|-----------------------------------------------------------------------------------------------------------------------|
| Groups  | To view all the Incinerator Node groups.                                                                              |
| Nodes   | To view all Incinerator Nodes on the Incinerator system.                                                              |
| Servers | To view all machines running the <i>BrowseD</i> daemon, including the Lustre Media Server, on the Incinerator system. |

A list of all Incinerator Nodes, Incinerator Node groups, or Lustre Media Servers on the Incinerator system appears.

3. Click the Incinerator Node, Incinerator Node group, or Lustre Media Server to be stopped from the list.  
Details for the selection appear. Use the Stop and Start buttons in the Resource Manager to control the node or server.

- Click Stop to stop the Incinerator Node, Incinerator Node group, or Lustre Media Server.

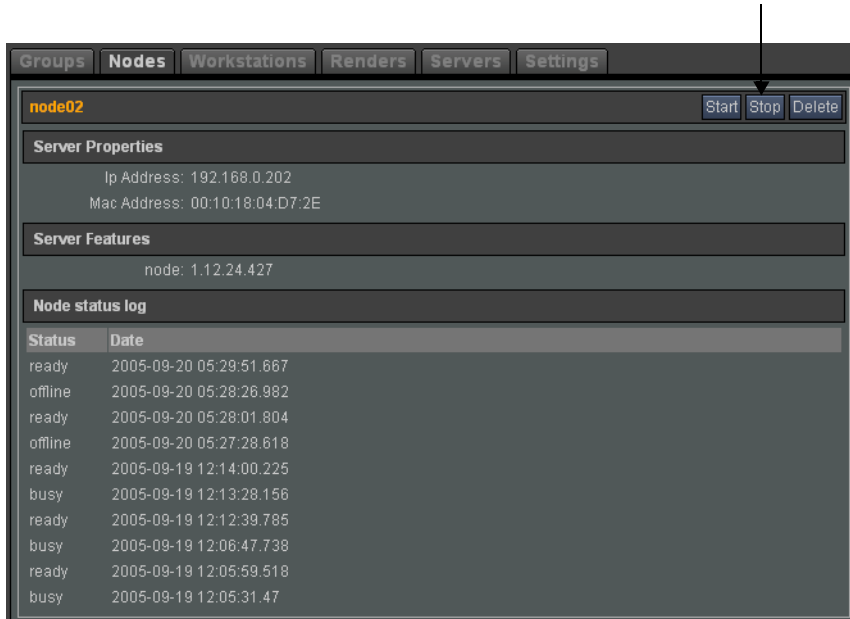

The Incinerator Node, Incinerator Node group, or Lustre Media Server is stopped and its status changes in the Resource Manager.

| Name   | Status  | Ip address    | Mac address       | Groups            |
|--------|---------|---------------|-------------------|-------------------|
| node02 | offline | 192.168.0.202 | 00:10:18:04:D7:2E | group,Incinerator |
| node03 | ready   | 192.168.0.203 | 00:10:18:09:FF:AA | group,Incinerator |
| node04 | ready   | 192.168.0.204 | 00:10:18:04:D4:42 | group,Incinerator |
| node05 | ready   | 192.168.0.205 | 00:10:18:04:D4:E6 | group,Incinerator |
| node06 | ready   | 192.168.0.206 | 00:10:18:04:D6:4E | group,Incinerator |
| node01 | ready   | 192.168.0.201 | 00:10:18:04:D7:1C | group,Incinerator |
| node08 | ready   | 192.168.0.208 | 00:10:18:04:D9:9B | group,Incinerator |
| node07 | ready   | 192.168.0.207 | 00:10:18:04:D4:6C | group,Incinerator |

- Click Start to restart the Incinerator Node, Incinerator Node group, or Lustre Media Server. The Incinerator Node, Incinerator Node group, or Lustre Media Server is restarted and its status changes in the Resource Manager.

**HINT:** Click Refresh List if the status does not appear to change.

## Deleting Duplicate Lustre Media Servers, Workstations, and Nodes

When an Incinerator system component starts up, it is tracked by its IP address in the Resource Manager database. If you change the IP address of the component, the original IP address of the component remains in the database, creating two entries for the same component in the Resource Manager.

If you change the IP address of a component on the Incinerator system, you must delete the component with the old IP address from the Resource Manager. Otherwise, duplicate entries for the same device appear.

You can delete duplicate Lustre Media Servers, workstations, and Incinerator Nodes. In order to delete these components, you may require permission to administer groups and nodes. See [“Managing Permissions”](#) on page 94.

**NOTE:** If you delete the wrong component, just restart the daemon on the Lustre Media Server or node, or restart the workstation, and the Resource Manager is updated to display the active component.

### To delete duplicate Lustre Media Servers, workstations, and Incinerator Nodes:

1. If necessary, log in to the Resource Manager with a user account that has rights to administer groups and nodes. See [“Logging In and Logging Out of the Incinerator Resource Manager”](#) on page 69.
2. Click the tab that lists the components you want to delete.

| Select: | To:                                                                                                                   |
|---------|-----------------------------------------------------------------------------------------------------------------------|
| Groups  | To view all the Incinerator Node groups.                                                                              |
| Nodes   | To view all Incinerator Nodes on the Incinerator system.                                                              |
| Servers | To view all machines running the <i>BrowseD</i> daemon, including the Lustre Media Server, on the Incinerator system. |

A list of all Incinerator Nodes, Incinerator Node groups, or Lustre Media Servers on the Incinerator system appears.

3. Click the Incinerator Node, Lustre Media Server, or workstation to be deleted from the list.

- Click Delete to delete the Incinerator Node, workstation, or Lustre Media Server.

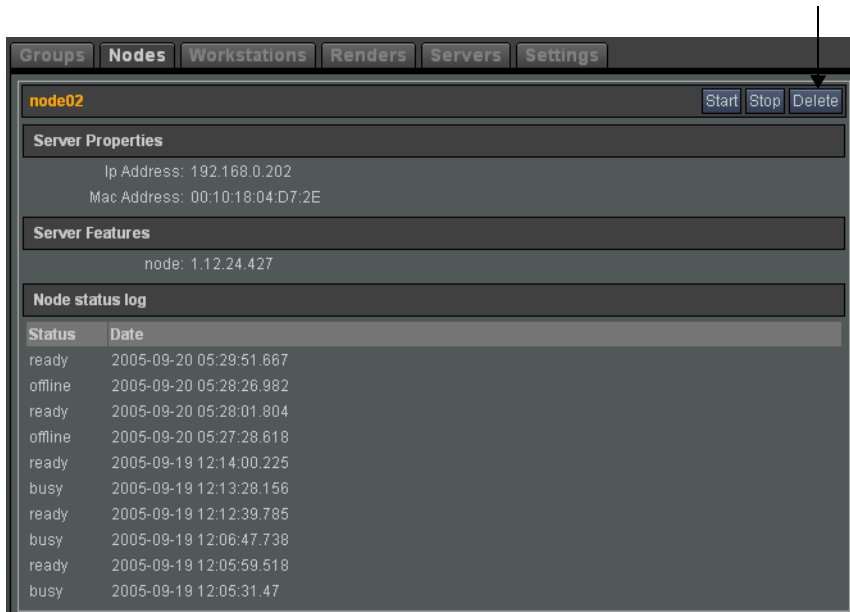

A dialog box opens and asks you to confirm that the component will be deleted.

- Click OK to delete the Incinerator Node, workstation, or Lustre Media Server.  
The component is removed from the Resource Manager tabs.

## Managing Resource Manager User Accounts

Create user accounts to control the rights that users have to manage the Incinerator system from the Resource Manager.

**NOTE:** User accounts and permissions for the Incinerator Resource Manager are different from Linux user accounts. You create and manage Resource Manager user accounts in the Resource Manager.

### Creating a New User Account

Create user accounts to control the rights that users have on the Incinerator system.

In order to create user accounts, you may require permission to administer users. See [“Managing Permissions”](#) on page 94.

**NOTE:** Values for the user name and password are case-sensitive. Be sure to use a consistent convention for choosing user names and passwords.

**To create a new user account:**

1. If necessary, log in to the Resource Manager with a user account that has permissions to administer users. See [“Logging In and Logging Out of the Incinerator Resource Manager”](#) on page 69.
2. Click the Settings tab.
3. In the Create new user panel, type the user name in the Name field.

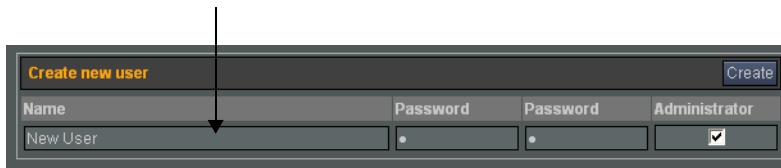

4. Type the user’s password in the Password field and confirm the password by typing it again in the second Password field.
5. To give this user administrator rights, select the Administrator option.
6. Click Create.

**Modifying a User Account Password**

You can modify the password of an existing Resource Manager user account.

You may require permissions to administer users in order to modify user account passwords. See [“Managing Permissions”](#) on page 94.

**To modify a user account password:**

1. If necessary, log in to the Resource Manager with a user account that has rights to administer users. See [“Logging In and Logging Out of the Incinerator Resource Manager”](#) on page 69.
2. Click the Settings tab.

3. In the Users panel, click Set Password next to the name of the user whose password you want to change.

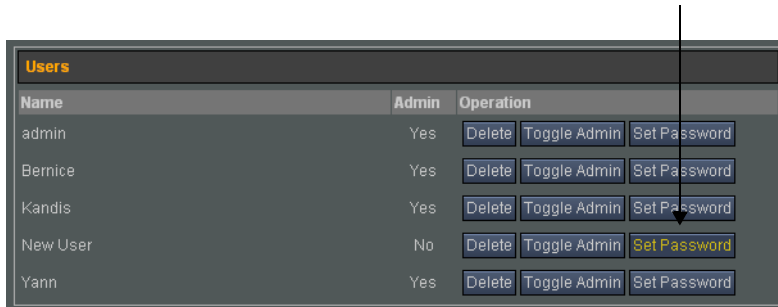

The Change password panel opens.

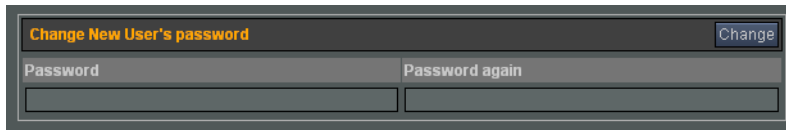

4. Type the user's new password in the Password field.
5. Confirm the new password by typing the same password in the Password again field.
6. Click Change.

## Adding or Removing Administrator Rights from a User Account

You can add or remove administrator rights from an existing Resource Manager user account. Users with administrative rights can perform all tasks that require administrator permissions.

In order to add or remove administrator rights from a user account, you may require permissions to administer users. See [“Managing Permissions”](#) on page 94.

### To add or remove administrative rights from a user account:

1. If necessary, log in to the Resource Manager with a user account that has permissions to administer users. See [“Logging In and Logging Out of the Incinerator Resource Manager”](#) on page 69.
2. Click the Settings tab.

The Admin column in the Users panel indicates whether a user has administrator rights.

| Name     | Admin | Operation                        |
|----------|-------|----------------------------------|
| admin    | Yes   | Delete Toggle Admin Set Password |
| Bernice  | Yes   | Delete Toggle Admin Set Password |
| Kandis   | Yes   | Delete Toggle Admin Set Password |
| New User | No    | Delete Toggle Admin Set Password |
| Yann     | Yes   | Delete Toggle Admin Set Password |

3. In the Users panel, click Toggle Admin next to the name of the user. This turns on and off the administrator rights for this user account.

| Name     | Admin | Operation                               |
|----------|-------|-----------------------------------------|
| admin    | Yes   | Delete Toggle Admin Set Password        |
| Bernice  | Yes   | Delete Toggle Admin Set Password        |
| Kandis   | Yes   | Delete Toggle Admin Set Password        |
| New User | No    | Delete <b>Toggle Admin</b> Set Password |
| Yann     | Yes   | Delete Toggle Admin Set Password        |

## Deleting a User Account

You can delete Resource Manager user accounts that you do not need.

In order to delete users, you may require permissions to administer users. See [“Managing Permissions”](#) on page 94.

**⚠ WARNING:** You cannot undo the deletion of a user. Be certain that you want to delete the selected user before you do.

### To delete a user account:

1. If necessary, log in to the Resource Manager with a user account that has permissions to administer users. See [“Logging In and Logging Out of the Incinerator Resource Manager”](#) on page 69.
2. Click the Settings tab.

3. In the Users panel, click Delete next to the name of the user you want to delete.

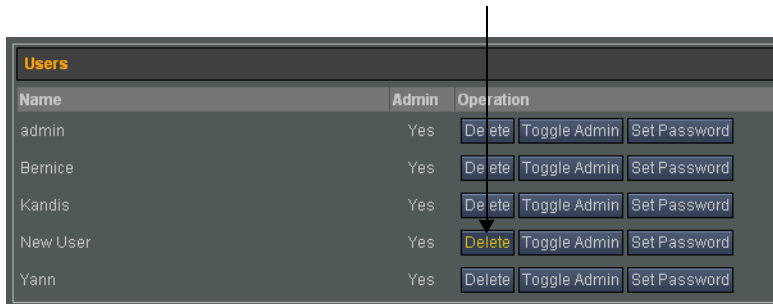

A dialog box appears and asks you to confirm that the user will be deleted.

4. Click OK to delete the user.

## Managing Permissions

When you start the Incinerator Resource Manager you are identified as the anonymous user by default. This user, as well as all other users that log in to the Resource Manager, can view the status of groups, nodes, workstations, and renders. However, the ability to perform other tasks in the Resource Manager can be limited to selected users.

From the Settings tab, you can limit the following tasks to selected users:

**Change settings** — Manage permissions from the Settings tab.

**Start/Stop Daemons** — Start and stop the *BrowseD* and *renderd* daemons from the Groups, Nodes, Workstations, and Servers tabs.

**Administer groups/nodes** — Create, modify, and delete groups and nodes from the Groups and Nodes tabs, as well as delete duplicate nodes, workstations, and Lustre Media Servers from the Nodes, Workstations, and Servers tabs.

**Administer users** — Create and delete users from the Settings tab.

To create an Incinerator Resource Manager user account, see [“Creating a New User Account”](#) on page 90. To add administrator rights to a user account, see [“Adding or Removing Administrator Rights from a User Account”](#) on page 92.

### To manage permissions:

1. Log in to the Resource Manager with a user account that has permission to administer users. See [“Logging In and Logging Out of the Incinerator Resource Manager”](#) on page 69.
2. Click the Settings tab.

- Identify the tasks that require specific user permissions.

| Select:   | To:                                                                                                                 |
|-----------|---------------------------------------------------------------------------------------------------------------------|
| Everybody | Enable any user, including the anonymous user, to perform the task.                                                 |
| User      | Limit the tasks to users that are logged in to the Resource Manager. The anonymous user cannot perform these tasks. |
| Admin     | Limit the task to administrators only.                                                                              |

- Click the Save button in the Permissions panel to save your changes.

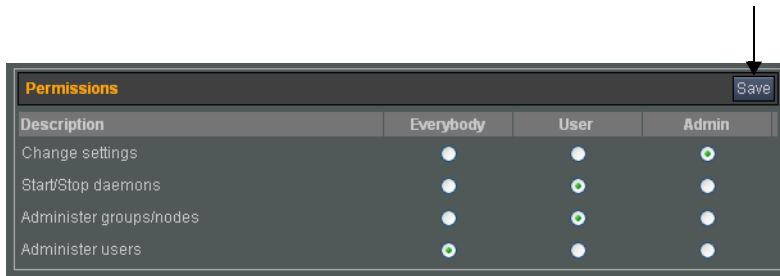



# Troubleshooting Tips



## Summary

|                                                                          |     |
|--------------------------------------------------------------------------|-----|
| <a href="#">Resolving Common Problems</a> .....                          | 97  |
| <a href="#">Stopping and Starting Incinerator Daemons Manually</a> ..... | 101 |
| <a href="#">Viewing Incinerator Daemon Log Files</a> .....               | 102 |
| <a href="#">Changing the IP Addressing Scheme</a> .....                  | 103 |
| <a href="#">InfiniBand Management</a> .....                              | 105 |

## Resolving Common Problems

This section provides a list of common problems that you may encounter on an Incinerator system and suggestions for how to resolve them.

| Problem                                                                                        | Common Cause                                                                                                                                                  |
|------------------------------------------------------------------------------------------------|---------------------------------------------------------------------------------------------------------------------------------------------------------------|
| The Incinerator Lustre Media Server takes a long time to start up.                             | There are unconnected ports on the fibre-channel adapter. See <a href="#">“Shortening Startup Time for the Incinerator Lustre Media Server”</a> on page 97.   |
| The monitor on the Lustre workstation flashes at startup, or the login screen does not appear. | The NVIDIA® driver or the <i>xorg.conf</i> file is incorrect. See <a href="#">“Checking the Workstation Graphics Driver and Monitor Settings”</a> on page 98. |
| Playback is not real-time.                                                                     | There are a number of possible causes for this problem. See <a href="#">“Troubleshooting Problems with Real-Time Playback”</a> on page 101.                   |

### Shortening Startup Time for the Incinerator Lustre Media Server

If the Lustre Media Server takes a long time to start up, check the messages on the boot screen. If the messages indicate that the kernel is waiting for the fibre channel driver, make sure all ports on the fibre channel cards are either connected to a storage device or have fibre-channel loops attached. The fibre channel driver may wait several minutes for each unconnected port before it times out.

## Checking the Workstation Graphics Driver and Monitor Settings

Both the graphics driver and the *xorg.conf* file must be correct for the graphics to appear on a Lustre workstation. Use the following list to diagnose graphics problems, such as not being able to log in to the Lustre workstation.

**NOTE:** The flashing NVIDIA logo or login screen problems can also be caused by bad connections on any device. Before you continue troubleshooting the graphics driver and monitor settings, ensure that all devices are properly connected. You can also check the */var/log/Xorg.0.log* file for device errors.

| Problem:                                                                     | Common Cause                                                                                                                                                                         |
|------------------------------------------------------------------------------|--------------------------------------------------------------------------------------------------------------------------------------------------------------------------------------|
| NVIDIA logo flashes endlessly on the graphics monitor.                       | The wrong NVIDIA graphics driver is installed. See <a href="#">“Checking the NVIDIA Graphics Driver”</a> on page 98.                                                                 |
| The login screen does not appear or appears garbled on the graphics monitor. | The <i>xorg.conf</i> file does not contain the correct configuration information for the graphics monitor. See <a href="#">“Checking the Graphics Monitor Settings”</a> on page 100. |

### Checking the NVIDIA Graphics Driver

Ensure that the correct version of the NVIDIA graphics driver is installed on a Lustre workstation.

**NOTE:** At the time this document is being written, the correct version is 165.33.11 for Linux. However, the graphics driver is subject to change. Please check with Customer Support for the latest certified driver.

#### To check the installed version of the NVIDIA graphics driver:

1. Reboot the Lustre workstation.
2. Log in as root and then view the version of the NVIDIA driver that is installed on the Lustre workstation. Type:

```
cat /proc/driver/nvidia/version
```

If the correct version of the NVIDIA graphics driver is installed, the following line appears in the output:

```
NVRM version: NVIDIA Linux x86_64 Kernel Module 1.0-<version>
```

where *<version>* is the version number of the driver. For example, at the time this document is being written, the correct version is 165.33, so the output would be:

```
NVRM version: NVIDIA Linux x86_64 Kernel Module 1.0-16250
```

If this line does not appear or is different, the NVIDIA graphics driver version may be wrong or missing. Use the next procedure to install the correct version of the NVIDIA graphics driver.

**To install the NVIDIA driver:**

1. Reboot the Lustre workstation and press **A** when the GRUB boot screen appears.

**NOTE:** If a flashing NVIDIA logo prevents you from logging in to reboot the workstation, try logging in as root from another workstation on the Incinerator system and performing a reboot remotely.

2. When the GRUB boot prompt appears, configure the workstation to boot in text-only mode by typing **3** and pressing **ENTER**.

The workstation boots in text-only mode and you are prompted to log in.

3. Log in as root and navigate to the folder containing the script that updates the NVIDIA driver. Type:

```
cd /usr/discreet/DKU/DKU_<DKU_version>/bin/system_rpm
```

where `<DKU_version>` is the DKU version for your release. For example, if your DKU version is 3.5.0, type:

```
cd /usr/discreet/DKU/DKU_3.5.0/bin/system_rpm
```

4. Launch the script by typing:

```
sh ./NVIDIA-Linux-x86_64-165.33-<driver_version>-pkg2.run
```

where `<driver_version>` is the correct driver version. For example, if your driver version is 11, type:

```
sh ./NVIDIA-Linux-x86_64-164.33-11-pkg2.run
```

5. When prompted with the license agreement, click Accept.
6. If you are prompted to remove the previous driver version, click Yes.
7. When prompted to download the latest NVIDIA driver from the FTP site, click No.
8. When prompted to recompile the NVIDIA driver, click OK.
9. Restart the X server on the workstation by typing:

```
init 5
```

This sets the workstation to run in graphics mode. You should be able to log in using the graphical user interface.

### Checking the Graphics Monitor Settings

The *xorg.conf* file contains settings for all peripherals attached to a Lustre workstation, including the graphics monitor. If these settings are not correct, the graphics monitor may not display output correctly or may appear blank, even though the workstation has booted properly. Do the following to check the settings for the graphics monitor in the *xorg.conf* file.

#### To check graphics monitor settings in the *xorg.conf* file:

1. Reboot the Lustre workstation and press **A** when the GRUB boot screen appears.
 

**NOTE:** If a flashing NVIDIA logo prevents you from logging in to reboot the workstation, try logging in as root from another workstation on the Incinerator system and performing a reboot remotely.
2. When the GRUB boot prompt appears, configure the workstation to boot in text-only mode by typing **3** and pressing **ENTER**.
 

The workstation boots in text-only mode and you are prompted to log in.
3. Log in as root.
4. Create a backup of the current *xorg.conf* file. Type:
 

```
cp /etc/X11/xorg.conf /etc/X11/xorg.conf_backup
```
5. Using a text editor such as *vi*, view the *xorg.conf* file by typing:
 

```
vi /etc/X11/xorg.conf
```

The *xorg.conf* file appears.
6. Ensure the screen that is selected is *Screen Lustre / EIZO CE24xW FX5600 SDI 1920X1200*.
7. Close the current *xorg.conf* file in *vi* by pressing **ESC** and then typing **:w!**.
8. Restart the Lustre workstation by typing:
 

```
init 5
```

## Troubleshooting Problems with Real-Time Playback

The most common sources of problems with real-time playback are out-of-sequence image files on the storage, multiple copies of the image sequence on the storage, storage bandwidth, video output issues, and complexity of clip setups. Use the following as a checklist to try to narrow down the source of your particular problem. If none of these appear to be the problem, or you are unsure how to resolve the problem, contact Customer Support.

- Make sure that the image sequence is written sequentially on the storage. If the sequence is not written sequentially, the time required to retrieve the individual frames may impact real-time performance. For example, if you have two folders with scans to transfer to storage, you must copy those folders one after the other. If you copy both folders at the same time or copy the second before the first copy is complete, the contents of the folders will not be written sequentially to the disks in the storage.
- If the clip is on a Storage Area Network (SAN), make sure the host machine has the bandwidth required for real-time playback.
- Make sure you can play back the cut file associated with the grade in real time when the Incinerator nodes are disconnected. Be sure to load only the cut, not the grade.
- Determine whether you can achieve real-time playback when you disable your DVS or NVIDIA video output.
- An Incinerator storage system should be able to sustain a minimum of a 2K clip stream (2048 x 1556 DPX 10-bits) when the Incinerator nodes are disconnected. First verify that the images can be played back in real time, without any colour correction applied and with the Incinerator nodes disconnected. If this is possible, try connecting the Incinerator nodes and loading a grade. If real-time playback of the grade is not possible, try disabling a selective, disabling effects, or cropping the image and observe any impact on performance.

## Stopping and Starting Incinerator Daemons Manually

Incinerator relies upon the following daemons to provide real-time playback to Lustre, and for Incinerator network management.

**BrowseD** — Runs on the Lustre Media Server. It provides access to frames on its storage.

**cmangerd** — Runs on the Lustre Media Server. It collects status information from *renderd* and *BrowseD* and stores this information in a database that is used to populate the Incinerator Resource Manager.

**renderd** — Runs on the Incinerator Nodes. It renders the frames with the grades and effects and sends them to the Lustre workstation for real-time playback.

Under most circumstances, you can start and stop *BrowseD* and *renderd* using the Incinerator Resource Manager. See [“Stopping and Starting Incinerator Daemons”](#) on page 86.

However, if you change configuration files, you must restart *BrowseD*, *renderd*, and *cmanagerd* manually. See the following table to determine when modifications to a configuration file require a manual restart of a daemon.

| When You Change:            | On Component:       | Manually Restart Daemon: |
|-----------------------------|---------------------|--------------------------|
| <i>cmanagerdclient.conf</i> | Lustre Media Server | <i>BrowseD</i>           |
| <i>cmanagerd.conf</i>       | Lustre Media Server | <i>cmanagerd</i>         |
| <i>cmanagerdclient.conf</i> | Incinerator Nodes   | <i>renderd</i>           |

**To restart Incinerator daemons manually:**

1. Log in as root to the machine and open a shell.
2. Use the following table to select the command for the daemon you want to restart.

| Component           | Daemon           | Command                                         |
|---------------------|------------------|-------------------------------------------------|
| Lustre Media Server | <i>BrowseD</i>   | <code>/etc/init.d/browseed_2009 restart</code>  |
| Lustre Media Server | <i>cmanagerd</i> | <code>/etc/init.d/cmanagerd_2009 restart</code> |
| Incinerator Node    | <i>renderd</i>   | <code>/etc/init.d/renderd_2009 restart</code>   |

## Viewing Incinerator Daemon Log Files

Many events in Incinerator are recorded in log files. A good troubleshooting strategy is to view the last few event(s) recorded in the log files before the problem occurred. These files can help you recreate the series of events leading up to the problem and may indicate or identify its cause. You may also be requested by Customer Support to send copies of your log files to help them troubleshoot the problem.

You can view log files for the following Incinerator-related daemons:

- *BrowseD* on the Lustre Media Server.
- *renderd* on the Incinerator Nodes.
- *cmanagerd* on the Lustre Media Server.

Use the following procedure to view the log files for either daemon.

**To view Incinerator log files:**

1. Log in as root to the Lustre Media Server, Lustre workstation, or Incinerator Node.
2. Navigate to the directory containing the log files (*/var/log*) by typing:

```
cd /var/log
```

- Type one of the following commands to display the Incinerator-related log file in this directory.

| For:             | Type:                         |
|------------------|-------------------------------|
| <i>BrowseD</i>   | <b>ls   grep -i browsed</b>   |
| <i>cmanagerd</i> | <b>ls   grep -i cmanagerd</b> |
| <i>renderd</i>   | <b>ls   grep -i renderd</b>   |

The appropriate log file appears in the output. If no log file appears, the daemon may not be started on the Lustre Media Server or Incinerator Node.

- Do one of the following to view the contents of the log file:
  - Use the `tail` command to view the last few lines of the log file.
  - Use the `more` command to view the log file in its entirety.
  - Copy the log file to another workstation on the network and open it in a text editor.

## Changing the IP Addressing Scheme

The Incinerator system comes shipped with the following default IP addressing scheme.

| Component           | GigE IP Address | GigE Subnet Mask | InfiniBand IP Address | InfiniBand Subnet Mask |
|---------------------|-----------------|------------------|-----------------------|------------------------|
| Lustre Media Server | 10.10.10.x      | 255.255.255.0    | 10.10.11.x            | 255.255.255.0          |
| Nodes               | 10.10.10.10x    | 255.255.255.0    | 10.10.11.10x          | 255.255.255.0          |
| Workstation         | 10.10.10.20x    | 255.255.255.0    | 10.10.11.20x          | 255.255.255.0          |

If you decide to change the IP addressing scheme of the Incinerator system after you receive it, there are a number of configuration files that must be changed and daemons that must be restarted.

The following procedure outlines the workflow you should follow when changing the IP addressing scheme of your Incinerator system.

### To change the IP addressing scheme:

- Update the network configuration on all components. Do the nodes, workstation, and then the Lustre Media Server.

The following configuration files must be updated on all components:

- `/etc/hosts`
- `/etc/sysconfig/network-scripts/ifcfg-<host adapter>`

After you make all of these changes on a machine, reboot the machine and continue to the next machine.

After you have updated the network configuration on all machines, use **ping** to test communication between all components on both the InfiniBand and GigE networks before you continue.

2. After you have changed the network settings on all the components, start working on the Lustre Media Server to update the configuration files and to restart services.

Update *cmanagerdclient.conf* with the latest IP address of the Lustre Media Server. See [“cmanagerdclient.conf”](#) on page 61.

Then, manually restart the license server. In a shell, type:

```
/etc/init.d/license_server restart
```

Next, restart *cmanagerd* and *BrowseD* manually. See [“Stopping and Starting Incinerator Daemons Manually”](#) on page 101.

Finally, check the Incinerator Resource Manager in a Web browser. The Manager status should appear as “online” and the Lustre Media Server should appear on the Servers tab with the status “ready”. See [Chapter 8, “Using the Incinerator Resource Manager,”](#) on page 67.

3. After the Lustre Media Server is updated, move to the nodes to update the configuration files and restart the daemons.

Update */usr/autodesk/lustre2009/cmanagerdclient.conf* with the latest IP address of the Lustre Media Server.

Next, restart the *renderd* daemon manually.

Finally, check the Incinerator Resource Manager in a Web browser. The Incinerator Nodes should appear on the Groups and Nodes tabs with the status “ready”.

4. On the workstation, update the *cmanagerdclient.conf* and *browsed.config* files with the latest IP address of the Lustre Media Server. For information on *BrowseD*, see [“init.config”](#) on page 60.

When you are done with the updates restart Lustre and check the Incinerator Resource Manager in a Web browser. The workstation should appear on the Workstation tab with the status “ready”.

5. If you have any projects that were created before you changed the IP addressing scheme, you must update the project paths to point to the GigE address of the Lustre Media Server. In addition, if you had previously connected to Incinerator Node Groups from the Render|Cluster menu in Lustre, you must remove the old groups and reconnect to the new

ones to enable real-time playback with Incinerator. See [“Using Lustre with Incinerator”](#) on page 62.

**NOTE:** If any of the components were connected to the Incinerator Resource Manager before you changed your IP addressing scheme, you will have duplicate entries in the Resource Manager. To delete duplicate entries in the Resource Manager, see [“Deleting Duplicate Lustre Media Servers, Workstations, and Nodes”](#) on page 89.

## InfiniBand Management

There are two noteworthy InfiniBand network management and logging facilities. The following two sections describe these facilities.

For more information about configuring, monitoring, and managing the InfiniBand switch and network, see the documentation provided by the manufacturer of the switch.

### Reviewing Port Statistics Using the InfiniView Web Monitor

The InfiniBand switch comes with a Web-based application, the InfiniView Device Manager™, that you can use to configure, monitor, and manage the InfiniBand network. To access the Device Manager, your browser must be on the same subnet as the InfiniBand switch, which has a default IP address of 192.168.100.9.

The following illustration shows the main page of the Device Manager.



If you click the Port Stats link on the main page, the IB Port Statistics page opens.

| Port Name | Port # | Link State | Physical State | Link Down Default | Active Link Width | Link Width Enabled | Link Width Supported | Active Link Speed | Link Speed Enabled | Link Speed Supported | Transmit 32Bit Words | Receive 32Bit Words | Transmit Packets | Receive Packets | Transmit Wait | Symbol Errors |
|-----------|--------|------------|----------------|-------------------|-------------------|--------------------|----------------------|-------------------|--------------------|----------------------|----------------------|---------------------|------------------|-----------------|---------------|---------------|
| Cable 1   | 1.1    | active     | Up             | Polling           | 4X                | 4X                 | 1X or 4X             | 2.5Gb/s           | 2.5Gb/s            | 2.5Gb/s              | 754212507            | 748212488           | 2881936          | 2859139         | 0             | 0             |
| Cable 2   | 1.2    | active     | Up             | Polling           | 4X                | 4X                 | 1X or 4X             | 2.5Gb/s           | 2.5Gb/s            | 2.5Gb/s              | 751891896            | 745623576           | 2873068          | 2849248         | 0             | 0             |
| Cable 3   | 1.3    | active     | Up             | Polling           | 4X                | 4X                 | 1X or 4X             | 2.5Gb/s           | 2.5Gb/s            | 2.5Gb/s              | 744929991            | 737856756           | 2846463          | 2819573         | 0             | 0             |
| Cable 4   | 1.4    | active     | Up             | Polling           | 4X                | 4X                 | 1X or 4X             | 2.5Gb/s           | 2.5Gb/s            | 2.5Gb/s              | 744929991            | 737856756           | 2846463          | 2819573         | 0             | 0             |
| Cable 5   | 1.5    | active     | Up             | Polling           | 4X                | 4X                 | 1X or 4X             | 2.5Gb/s           | 2.5Gb/s            | 2.5Gb/s              | 742609387            | 735268126           | 2837596          | 2800683         | 0             | 0             |
| Cable 6   | 1.6    | active     | Up             | Polling           | 4X                | 4X                 | 1X or 4X             | 2.5Gb/s           | 2.5Gb/s            | 2.5Gb/s              | 740288841            | 732679116           | 2828728          | 2799793         | 0             | 0             |
| Cable 7   | 1.7    | active     | Up             | Polling           | 4X                | 4X                 | 1X or 4X             | 2.5Gb/s           | 2.5Gb/s            | 2.5Gb/s              | 740289031            | 732678979           | 2828728          | 2799792         | 0             | 0             |
| Cable 8   | 1.8    | active     | Up             | Polling           | 4X                | 4X                 | 1X or 4X             | 2.5Gb/s           | 2.5Gb/s            | 2.5Gb/s              | 735847547            | 727501188           | 2810891          | 2780009         | 0             | 0             |
| Cable 9   | 1.9    | active     | Up             | Polling           | 4X                | 4X                 | 1X or 4X             | 2.5Gb/s           | 2.5Gb/s            | 2.5Gb/s              | 196259               | 4294967295          | 25892            | 22727341        | 0             | 0             |
| Cable10   | 1.10   | active     | Up             | Polling           | 4X                | 4X                 | 1X or 4X             | 2.5Gb/s           | 2.5Gb/s            | 2.5Gb/s              | 4294967295           | 195429              | 22509150         | 25337           | 0             | 0             |
| Cable11   | 1.11   | down       | Polling        | Polling           | 4X                | 1X or 4X           | 1X or 4X             | 2.5Gb/s           | 2.5Gb/s            | 2.5Gb/s              | 0                    | 0                   | 0                | 0               | 0             | 0             |
| Cable12   | 1.12   | down       | Polling        | Polling           | 4X                | 1X or 4X           | 1X or 4X             | 2.5Gb/s           | 2.5Gb/s            | 2.5Gb/s              | 0                    | 0                   | 0                | 0               | 0             | 0             |
| Cable13   | 1.13   | down       | Polling        | Polling           | 4X                | 1X or 4X           | 1X or 4X             | 2.5Gb/s           | 2.5Gb/s            | 2.5Gb/s              | 0                    | 0                   | 0                | 0               | 0             | 0             |

In the IB Port Statistics page, you can check the status of each port on the switch. To update the data that displays on the page, be sure to click the Refresh button.

## Reviewing Statistics and Information for a Port

There are two commands packaged with the InfiniBand driver that provide statistics and information about a port. The information provided by these commands is similar to that displayed in the InfiniView Device Manager.

### To review statistics and information about a port:

1. Log in to the machine as root.
2. Type the following commands in a shell:

```
cat /proc/iba/mt23108/1/port<x>/stats
```

```
cat /proc/iba/mt23108/1/port<x>/info
```

where <x> is the port number on the device.

A report appears in the shell.

## Generating InfiniBand Log Files for Support

The script `/sbin/iba_capture` gathers information about your system and InfiniBand configurations that can be useful for troubleshooting InfiniBand issues. This script outputs a GZIP file.

### To run the InfiniBand log file capture script:

- As root, open a shell and type:

```
/sbin/iba_capture <path and name of output gzip file>
```

A GZIP file is generated that includes a number of log files from your system.

**NOTE:** The help for this command indicates that the output is a TAR file, when it is in fact a GZIP file.



# Configuring Background Rendering



## Summary

|                                                                                      |     |
|--------------------------------------------------------------------------------------|-----|
| <a href="#">Software for Background Rendering</a> .....                              | 109 |
| <a href="#">Workflow for Setting Up Background Rendering</a> .....                   | 110 |
| <a href="#">Installing Backburner Manager and Backburner Web Monitor</a> .....       | 110 |
| <a href="#">Configuring Lustre to Connect to Backburner Manager</a> .....            | 111 |
| <a href="#">Installing and Configuring Burn for Lustre</a> .....                     | 112 |
| <a href="#">Configuring Backburner Server to Connect to Backburner Manager</a> ..... | 112 |
| <a href="#">Starting Backburner Server</a> .....                                     | 113 |
| <a href="#">Licensing Burn for Lustre</a> .....                                      | 113 |
| <a href="#">Specifying the Background Rendering Path in Lustre</a> .....             | 114 |
| <a href="#">Using BrowseD for Rendering with Burn for Lustre</a> .....               | 115 |

## Software for Background Rendering

You use the following software to perform background rendering.

| Software               | Description                                                                                                          | Host                                                         |
|------------------------|----------------------------------------------------------------------------------------------------------------------|--------------------------------------------------------------|
| Lustre application     | Initiates requests for background renders.                                                                           | Grading workstation                                          |
| Backburner Manager     | Receives all requests for background renders and dispatches these requests to Backburner Servers.                    | Lustre Media Server (recommended)                            |
| Backburner Server      | Receives requests for background renders from Backburner Manager and hands these to the Burn for Lustre application. | Each node on which you want to perform background rendering. |
| Burn for Lustre        | Performs the background renders.                                                                                     | Each node on which you want to perform background rendering. |
| Backburner Web Monitor | Provides a Web interface to the background render queue™ of Backburner Manager.                                      | Lustre Media Server (recommended)                            |

**NOTE:** Both Backburner Manager and Backburner Server use a Lustre-specific plug-in. This plug-in is installed automatically when you install Backburner Manager or Backburner Server.

## Workflow for Setting Up Background Rendering

Use the following workflow to set up background rendering in an Incinerator configuration. You can use this workflow either to configure inline render nodes to also serve as background render nodes, or to add dedicated background render nodes to your Incinerator configuration.

You can set up as many as eight render nodes for background rendering with Incinerator.

**NOTE:** This workflow assumes that Linux is already installed on the node. If this is not the case, refer to the *Linux RHEW 4, Update 3 Installation and Configuration Guide* for help installing Linux. If you must install Linux from scratch on an inline rendering node, be sure the inline rendering software is installed prior to setting up the node to also perform background rendering. Refer to [“Installing the Incinerator Node Software”](#) on page 51.

| Step:                                                                                                                                      | Refer to:                                                                                     |
|--------------------------------------------------------------------------------------------------------------------------------------------|-----------------------------------------------------------------------------------------------|
| 1. Install and configure Backburner Manager and Backburner Web Monitor.                                                                    | <a href="#">“Installing Backburner Manager and Backburner Web Monitor”</a> on page 110.       |
| 2. Configure the Lustre workstation to connect to Backburner Manager so that it can send background render requests to Backburner Manager. | <a href="#">“Configuring Lustre to Connect to Backburner Manager”</a> on page 111.            |
| 3. (Dedicated background render nodes only) Install Burn for Lustre on each render node.                                                   | <a href="#">“Installing and Configuring Burn for Lustre”</a> on page 112.                     |
| 4. Configure each render node to connect to Backburner Manager.                                                                            | <a href="#">“Configuring Backburner Server to Connect to Backburner Manager”</a> on page 112. |
| 5. Start Backburner Server on each render node.                                                                                            | <a href="#">“Starting Backburner Server”</a> on page 113.                                     |
| 6. License the nodes for background rendering.                                                                                             | <a href="#">“Licensing Burn for Lustre”</a> on page 113.                                      |
| 7. Set up the path for background rendering in the Lustre application.                                                                     | <a href="#">“Specifying the Background Rendering Path in Lustre”</a> on page 114.             |

## Installing Backburner Manager and Backburner Web Monitor

It is recommended that you install Backburner Manager and Backburner Web Monitor on the Lustre Media Server. For help installing both of these, and help starting and configuring Backburner Manager, refer to the *Autodesk Backburner 2008.1 Installation and User Guide*.

After you install Backburner Manager, you can use the following procedure to verify it is running.

**To verify Backburner Manager is running:**

- On the system on which you installed Backburner Manager, as root, type:

```
ps -ef | grep -i backburner
```

The output of the command should include a line containing the path to the Backburner Manager application, similar to the following:

```
root 14989 1 0 Nov29 ? 00:02:36 /usr/discreet/backburner/  
backburnerManager
```

**NOTE:** If Backburner Manager is not running, the Backburner log file */usr/discreet/backburner/Network/backburner.log* may be a useful source of information for troubleshooting.

## Configuring Lustre to Connect to Backburner Manager

For Backburner Manager to receive render jobs, you must set up the Incinerator application to connect to the system on which Backburner Manager is running.

To configure select or existing projects to use background rendering, you must set the IP address of the Backburner Manager workstation in the *init.config* file of the specific project.

If you installed Backburner Manager on the Lustre Media Server, the IP address you use is that of the Lustre Media Server.

**To configure the Incinerator application to connect to Backburner Manager:**

1. Using a text editor such as *nedit*, open the *init.config* file. Type:

```
nedit init.config
```

2. In the `Backburner_HostName` line, enter the IP address of the system on which Backburner Manager is installed (in the recommended configuration the Lustre Media Server). For example:

```
Backburner_HostName string="10.10.10.1"
```

**NOTE:** Do not add any extra spaces or extra lines to this file, or its functionality will be compromised.

3. Save the configuration file.

## Installing and Configuring Burn for Lustre

If you are setting up background rendering on an Incinerator node (so that it can serve for both inline and background rendering), you can skip this step. Burn for Lustre was installed when you installed the Incinerator node software.

If you are setting up dedicated background render nodes, you must install Burn for Lustre on each of those nodes.

**NOTE:** When you install Burn for Lustre, the Backburner Server application is also installed on the render node.

### To install Burn for Incinerator:

1. Open a Linux shell and log in as *root*.
2. Insert the Autodesk Lustre 2009 CD into the CD-ROM drive.
3. Go to the Lustre 2009 folder on the CD-ROM. Type:

```
cd /mnt/cdrom/lustre_2009_Renderer
```

4. Start the installation script by typing:

```
./INSTALL_LUSTRE2009
```

The Incinerator package is installed.

5. Repeat this procedure on all render nodes.

## Configuring Backburner Server to Connect to Backburner Manager

Backburner Server needs to be able to connect to Backburner Manager in order to provide status information concerning the render jobs. You establish this connection by adding the IP address of the machine on which Backburner Manager is running to the *manager.host* configuration file. This file is located in the */usr/discreet/backburner/cfg* directory on each render node.

**NOTE:** This file should contain *only* the IP address of Backburner Manager. You cannot, for example, include comments or other information in this file.

### To configure Backburner Server to connect to Backburner Manager:

1. On each render node, open a shell and log in as *root*.
2. Type:

```
cd /usr/discreet/backburner/cfg
```

3. Use a Linux text editor such as *vi* to edit the file. For example, type:  
**vi manager.host**
4. Specify the IP address of the host where Backburner Manager is installed (in the recommended configuration, the Lustre Media Server). For example:  
**10.10.10.1**
5. To save the file, press **ESC**, type **:wq!**, and then press **ENTER**.

## Starting Backburner Server

You must start the Backburner Server daemon on each Linux system for the first time. Once it is started the first time, the daemon will start automatically on reboot.

### To start Backburner Server:

1. Log in to your Linux system as *root*.
2. Type:  
**/etc/init.d/backburner\_server start**
3. You can verify that Backburner Server is properly configured by checking the log file *backburnerServer.log*. Type the following to view the file:  
**tail -f /usr/discreet/backburner/Network/  
backburnerServer.log**
4. To stop viewing the file, press **CTRL+C**.
5. Repeat these steps to start Backburner Server on each Linux server participating in the background rendering network.  
If you cannot start the Backburner Server, contact Customer Support.

**NOTE:** If you need to stop or restart Backburner Server, use one of these commands:

```
/etc/init.d/backburner_server stop  
/etc/init.d/backburner_server restart
```

## Licensing Burn for Lustre

Licenses for each node on which you want to perform background rendering are handled by the license server running on the Lustre Media Server. You install a single network license for background rendering in the license file the license server consults on the Lustre Media Server.

You then create a license file on each of the nodes that points to the license server running on the Lustre Media Server. The node contacts the license server to obtain its license.

The procedures in this section describe how to obtain and install the network license, and how to create the license file on each node on which you intend to perform background rendering. The procedures assume the license server is installed and running on the Lustre Media Server.

**To obtain and install the network license:**

1. Obtain the *lmhostid* of the Lustre Media Server.  
Refer to [“Obtaining the lmhostids”](#) on page 54.
2. Request a network license code for background rendering from the Autodesk Media and Entertainment Licensing Department.  
Refer to [“Requesting Incinerator License Codes”](#) on page 55.
3. Log in to the Lustre Media Server as root.
4. Open the license server license file `/usr/discreet/licserv/licenses/DL_license.dat` in a text editor such as *nedit* or *vi*.
5. Add the network license to the license file, then save and exit the license file.
6. Log in to each render node as root.
7. Open the license server license file `/usr/local/flexlm/licenses/DL_license.dat` in a text editor such as *nedit* or *vi*.
8. Add the `SERVER`, `VENDOR`, and `USE_SERVER` keywords and values provided to you by the Autodesk Media and Entertainment Licensing Department to the license file, then save and exit the license file. For example:

```
SERVER server 000255c720ce
```

```
VENDOR lustre
```

```
USE_SERVER
```

**NOTE:** Each render node must be able to contact the license server. Use the *ping* command on each node, with the IP address of the Lustre Media Server, to confirm that the two machines can communicate.

## Specifying the Background Rendering Path in Lustre

In the Incinerator | Render Backburner menu, you must specify the mount point that the render nodes use to mount the Lustre project folder.

**To add the storage path in Lustre:**

1. Start Incinerator.
2. In the Main menu, click Render, and then click Backburner.  
The Render Backburner menu appears.
3. Enter the location of the Project Home, Scans Full Home, Scans Half Home, Renders Full Home and Renders Half Home as seen from the Linux render nodes. You only need to enter those locations that are defined for the project in the local project setup, located in the Setup | Project menu.

The path required in these fields is comprised of the directory defined for the mount point and the actual storage folder. For example, if the Project Home is `/mnt/md0/SCENES` in the Project Setup menu, and the Linux mount point directory is named `Lustre_storage`, the Project Home path to enter in this menu is:

```
/mnt/Lustre_storage/SCENES
```

4. Press **ENTER**.
5. To verify that you have entered the proper path for each project, look at the project configuration file in `/usr/autodesk/lustre2009/project/<project name>/project.config`. The value in the `burn_project_home` line is sent to the Linux render node. This value must match a mount point on the background render nodes.

For help setting up and managing projects, refer to the *Autodesk Lustre 2009 User's Guide*.

## Using BrowseD for Rendering with Burn for Lustre

You must configure the Incinerator Render Backburner paths with the IP address of the BrowseD server to use BrowseD to render with Burn for Incinerator.

**To use BrowseD for rendering with Burn for Incinerator:**

1. In Incinerator, set the local project paths in the Setup Project menu. For information on configuring your projects, see the Lustre user guide.
2. Open the Network Rendering menu and add the IP address of the BrowseD server to each path.

For example, if your Project\_Home is set to the `bernice` directory on mount point `md0`: of a station that has an IP address of `10.10.10.1`, the Project\_Home path in the Render > Remote menu should read `10.10.10.1:/mnt/md0/bernice`.

**NOTE:** These path examples are specific to the Linux environment, and imply that the media frames are located on either an Incinerator 2009 workstation, or on a file server which is running

## **A** Configuring Background Rendering

the Linux operating system. If you are configuring the BrowseD path to connect to a Windows system, the paths are different.



# Software, Project, and User Configuration Files

## Summary

|                                                   |     |
|---------------------------------------------------|-----|
| <a href="#">Configuration File Overview</a> ..... | 117 |
| <a href="#">System Settings</a> .....             | 118 |

## Configuration File Overview

The configuration files define all the necessary settings Lustre needs to recognize various hardware and software settings on the Master Station or Lustre HD Station, and on the dedicated render station.

Before doing any colour correction in Lustre, you must first log into a project with a valid user profile. See the “Project Management” chapter in the *Lustre 2009 User Guide*. When you create a user profile and project in Lustre, you are indirectly creating the *user.config*, *project.config*, and *<user>Context.config* files. However, aside from the initial system configuration in the *init.config* file that you must set before you begin working, there is no need for you to manually create or modify any of the other configuration files. All of the configuration settings are set within Lustre’s user interface (refer to “System Settings” in the “Project Management” chapter of the *Lustre 2009 User Guide*).

When you log into a particular project in Lustre for the first time, Lustre creates the *<user>Context.config* file, where *<user>* represents the user name associated with the user profile. The context file is found in the *...\\projects\\<project>\\* folder in Windows and the *.../projects/<project>/* directory in Linux. The context keywords include some attributes not defined in the Project or User configuration settings. They are saved and reloaded each time the context (same user and project) applies. The context settings include:

- Last scene
- Last shot
- Resolution
- Crop value

- Assemble frame rate / drop frame mode
- State of the surface control
- Audio file

The following is a list of the Lustre configuration files.

| Configuration file                | Default Location                                                                                                                                                                       | Description                                                                                                                                                                                                                                                                                                                                           |
|-----------------------------------|----------------------------------------------------------------------------------------------------------------------------------------------------------------------------------------|-------------------------------------------------------------------------------------------------------------------------------------------------------------------------------------------------------------------------------------------------------------------------------------------------------------------------------------------------------|
| <i>init.config</i>                | Windows: C:\Program files\Autodesk\Lustre2009\<br>Linux: /usr/autodesk/lustre2009/                                                                                                     | This file stores system settings as well as Wiretap servers, Slave Render settings, and film stock information.                                                                                                                                                                                                                                       |
| <i>login.config</i>               | Windows: C:\Program Files\Autodesk\Lustre2009\<br>Linux: /usr/autodesk/lustre2009/                                                                                                     | This file records the last user and last project used so at the next session, the user and project login defaults will reflect these values.                                                                                                                                                                                                          |
| <i>project.config</i>             | Windows: C:\Autodesk\projects\ <i>&lt;project&gt;</i> \ <i>project.config</i><br>Linux: /usr/autodesk/projects/ <i>&lt;project&gt;</i> / <i>project.config</i>                         | This file stores project-level information including project settings, calibration, rendering, engineering, and BackBurner and Wiretap settings specific to the project.                                                                                                                                                                              |
| <i>user.config</i>                | Windows: C:\Autodesk\users\ <i>&lt;user&gt;</i> \ <i>user.config</i><br>Linux: /usr/autodesk/users/ <i>&lt;user&gt;</i> / <i>user.config</i>                                           | This file stores user settings specific to a particular user, such as Autosave, printer light, GUI background/gain/gamma.                                                                                                                                                                                                                             |
| <i>&lt;user&gt;Context.config</i> | Windows: C:\Autodesk\projects\ <i>&lt;project&gt;</i> \ <i>&lt;user&gt;Context.config</i><br>Linux: /usr/autodesk/projects/ <i>&lt;project&gt;</i> / <i>&lt;user&gt;Context.config</i> | This file stores several settings relevant to the context of a particular user working on a particular project. The purpose of storing context-specific information is that there are some parameter settings that, by their nature, are more likely to be needed in the next session, but that are not configurable in the Project Management pages. |

## System Settings

Before you first log into Lustre, you must configure the system settings in the *init.config* file (refer to “Configuring System Settings” in the “Project Management” chapter of the *Lustre 2009 User Guide*). If these system settings are not configured, Lustre uses the default system settings. The following table describes the relevant system settings that should be configured before the first login.

**NOTE:** All keyword values are case-sensitive.

| Parameter                                               | Data type                        | Default | Function                                                                                                                                                                                                                                                                                                                                                 |
|---------------------------------------------------------|----------------------------------|---------|----------------------------------------------------------------------------------------------------------------------------------------------------------------------------------------------------------------------------------------------------------------------------------------------------------------------------------------------------------|
| <b>&lt;Locations&gt;</b>                                |                                  |         |                                                                                                                                                                                                                                                                                                                                                          |
| <MainProjectHome>                                       | String                           |         | Location of the Project configuration settings folder.                                                                                                                                                                                                                                                                                                   |
| <MainUserHome>                                          | String                           |         | Location of the User configuration settings folder.                                                                                                                                                                                                                                                                                                      |
| <b>&lt;Wiretap&gt;</b>                                  |                                  |         |                                                                                                                                                                                                                                                                                                                                                          |
| <ServerAuto>                                            | State                            | On      | Specifies whether Lustre automatically scans for Wiretap servers.                                                                                                                                                                                                                                                                                        |
| <WiretapServer><br>(within<br><WiretapServer<br>Group>) | String                           | 0.0.0.0 | The IP address or DNS host name for a specific Wiretap server. If one or more <WiretapServer> keywords are set to valid Wiretap server addresses, Lustre lists the content of these servers in the browser before the results of the auto scan. If <ServerAuto> is set to OFF, only the specified Wiretap servers are listed in the browser.             |
| <b>&lt;MonitoringAndCalibration&gt;</b>                 |                                  |         |                                                                                                                                                                                                                                                                                                                                                          |
| <DisplayType>                                           | Enumerated<br>(abstract<br>data) | LCD     | Specifies the monitor display type (e.g., LCD or CRT).                                                                                                                                                                                                                                                                                                   |
| <Calibration_Steps>                                     | Integer                          | 10      | Specifies the number of monitor calibration steps performed.                                                                                                                                                                                                                                                                                             |
| <b>&lt;ControlSurface&gt;</b>                           |                                  |         |                                                                                                                                                                                                                                                                                                                                                          |
| <AutodeskPanels>                                        | State                            | On      | When ON, this keyword enables the Autodesk Control Surface (ACS). When OFF, Lustre enables the Tangent CP100 control surface (if applicable). You must also set the path for the control surface rules file in the Panel Setup File field (refer to "System & Menu Settings" in the "Project Management" chapter of the <i>Lustre 2009 User Guide</i> ). |

| Parameter                                            | Data type | Default                                             | Function                                                                                                                                                                                                |
|------------------------------------------------------|-----------|-----------------------------------------------------|---------------------------------------------------------------------------------------------------------------------------------------------------------------------------------------------------------|
| <PanellIDs>                                          |           | function="0"<br>grading="0"<br>navigation="0"       | The ID numbers for the Function, Navigation, and Grading panels of the ACS. You must manually configure these keywords. If your control surface is a Tangent CP100, Lustre does not use these keywords. |
| <PanellPTags>                                        |           | function="101"<br>grading="100"<br>navigation="102" |                                                                                                                                                                                                         |
| <BrowseD>                                            |           |                                                     |                                                                                                                                                                                                         |
| <Port>                                               | Integer   | 1055                                                | All computers on the BrowseD network must use the same port to communicate.                                                                                                                             |
| <Username>                                           | String    | Administrator                                       | Administrative user on the BrowseD server (e.g., root on Linux and Administrator on Windows).                                                                                                           |
| <Password>                                           | String    | xxx                                                 | Password for the administrative user.                                                                                                                                                                   |
| <UseInfi>                                            | State     | Off                                                 | Switch to ON if the networking protocol to use with BrowseD is the InfiniBand.                                                                                                                          |
| <ReadCacheBuffer Num>                                | Integer   | 0                                                   |                                                                                                                                                                                                         |
| <ReadCacheThread Num>                                | Integer   | 0                                                   |                                                                                                                                                                                                         |
| <BrowseDServer><br>(within<br><BrowseDServer Group>) | String    | 0.0.0.0                                             | Defines the IP address or DNS host name for a specific BrowseD server.                                                                                                                                  |
| <SlaveRenderer>                                      |           |                                                     |                                                                                                                                                                                                         |
| <HostName>                                           | String    |                                                     | The IP address or DNS host name for a specific Slave Render machine.                                                                                                                                    |
| <Timeout>                                            | Integer   | 5000                                                | Sets the timeout duration (in milliseconds) of the automatic slave renderer detection.                                                                                                                  |
| <Backburner>                                         |           |                                                     |                                                                                                                                                                                                         |
| <Hostname>                                           | String    |                                                     | The IP address or DNS host name for a specific Backburner Manager machine.                                                                                                                              |
| <MatchCustomGroup>                                   |           |                                                     |                                                                                                                                                                                                         |

| Parameter                          | Data type | Default                           | Function                                                                                                                                                                                                                                           |
|------------------------------------|-----------|-----------------------------------|----------------------------------------------------------------------------------------------------------------------------------------------------------------------------------------------------------------------------------------------------|
| <MatchCustom>                      | Name      | "AliasName"<br>type="s"           | Specifies the XML metadata field to be used by the Custom match option selected from the Browse menu.<br>"s" represents string.                                                                                                                    |
| <MatchCustom>                      | Name      | "DPXTimeCode"<br>type="tc"        | "tc" represents timecode.                                                                                                                                                                                                                          |
| <MatchCustom>                      | Name      | "DPXkeycode"<br>type="kk"         | "kk" represents keycode.                                                                                                                                                                                                                           |
| <MatchCustom>                      | Name      | "DPXTapeNAME"<br>type="s"         | "s" represents string.                                                                                                                                                                                                                             |
| <MatchCustom>                      | Name      | "EDLReelName"<br>type="s"         | "s" represents string.                                                                                                                                                                                                                             |
| <MatchCustom>                      | Name      | "DL_EDLClip_<br>name"<br>type="s" | "s" represents string.                                                                                                                                                                                                                             |
| <MatchCustom>                      | Name      | "DL_edlFrameID"<br>type="i"       | "i" represents integer.                                                                                                                                                                                                                            |
| <MatchCustom>                      | Name      | "DLEDL_startTC"<br>type="tc"      | "tc" represents timecode.                                                                                                                                                                                                                          |
| <AVIO>                             |           |                                   |                                                                                                                                                                                                                                                    |
| <PlayoutHighSpeed>                 | State     | Off                               | When OFF, it refreshes the Player as you are performing a playout. When ON, the Player is no longer refreshed and therefore the performance of the playout improves.<br>If you are using an IBM 6223 workstation, you must set this keyword to ON. |
| <WTTFirstSDLeadInCorrection>       | Integer   | 1                                 | Sets the delay for the SD first lead-in.                                                                                                                                                                                                           |
| <WTTSubsequentSDLeadInCorrection>  | Integer   | 2                                 | Delays all the lead-ins following the SD first shot.                                                                                                                                                                                               |
| <WTTSDLeadInIncrement>             | Integer   | 0                                 | Corrects the delay after the SD third shot.                                                                                                                                                                                                        |
| <WTTFirstHDLLeadInCorrection>      | Integer   | 0                                 | Sets the delay for the HD first lead-in.                                                                                                                                                                                                           |
| <WTTSubsequentHDLLeadInCorrection> | Integer   | 0                                 | Delays all the lead-ins following the HD first shot.                                                                                                                                                                                               |
| <WTHDLLeadInIncrement>             | Integer   | 0                                 | Corrects the delay after the HD third shot.                                                                                                                                                                                                        |

| Parameter                | Data type                  | Default | Function                                                                                                                                                                                                                             |
|--------------------------|----------------------------|---------|--------------------------------------------------------------------------------------------------------------------------------------------------------------------------------------------------------------------------------------|
| <Miscellaneous>          |                            |         |                                                                                                                                                                                                                                      |
| <DisablePanScan Frame>   | State                      | On      |                                                                                                                                                                                                                                      |
| <NVidiaSDISync>          | State                      | Off     |                                                                                                                                                                                                                                      |
| <NVidiaPlayoutDelay>     | Integer                    | 0       |                                                                                                                                                                                                                                      |
| <BlockSize>              | Integer                    | 2048    |                                                                                                                                                                                                                                      |
| <AudioResyncTime>        | Float                      | -1      |                                                                                                                                                                                                                                      |
| <LoadingSetup>           | Integer                    | 0       |                                                                                                                                                                                                                                      |
| <EnableKeycode Sending>  | Enumerated (abstract data) | Off     |                                                                                                                                                                                                                                      |
| <LoginGUIGain>           | Float                      | 1.0     |                                                                                                                                                                                                                                      |
| <LoginGUIImage>          | Float                      | 1.0     |                                                                                                                                                                                                                                      |
| <ClusterPlayDelay>       | Integer                    | 0       | Available for Incinerator only.                                                                                                                                                                                                      |
| <ClusterSmooth Playback> | State                      | Off     | Available for Incinerator only.                                                                                                                                                                                                      |
| <Debug>                  |                            |         |                                                                                                                                                                                                                                      |
| <DumpDLEDLPath>          | String                     |         | Path to place the contents of a DLEDL when it is loaded in the timeline or Shot bin.                                                                                                                                                 |
| <DumpWiretapCreate Clip> | State                      | Off     | When ON, the attributes of a Wiretap clip are placed into a log file each time a clip is created on a Wiretap server. The file <i>WiretapClipDump.log</i> is located in the Lustre home folder. Use this keyword for debugging only. |
| <FilmTypeGroup>          |                            |         |                                                                                                                                                                                                                                      |
| <FilmType>               | Name                       |         | Various film types for AGFA, Kodak™, Eastman, and Fuji emulsions. It defines the relationship between the DPX film emulsion code and the DPX film code number.                                                                       |

# index

## Index

### A

air conditioning requirements 13

### B

Backburner Manager

    detecting from Backburner Server 112

    detecting in Lustre 111

    installing 110

Backburner Server

    detecting Backburner Manager 112

    starting 113

Backburner Web Monitor, installing 110

background rendering 7

    configuring in Lustre 114

    licensing 113

    with BrowseD 115

    workflow for setting up 110

BIOS

    Incinerator Nodes 26

    Lustre Media Servers 24

    QLogic 27

    verifying and editing settings 22

    workstations 22

BrowseD 67

    configuration file 60

    license, installing 58

    log files 102

    monitoring 72

    remote rendering 115

browsed.config 60

Burn for Lustre, installing and configuring 112

### C

cmanagerd log files 102

cmanagerd.conf 60

cmanagerdclient.conf 61

Command Line Renderer, monitoring 75

components

    Incinerator 7

    installing rack-mounted 15

configuration file

    overview 117

configuration files

    BrowseD 60

    cmanagerd 60

    cmanagerdclient.conf 61

conventions, notation 4

### D

daemon

    configuration files 60

    log files 102

daemons

    BrowseD 67

    BrowseD configuration file 60

    cmanagerd configuration file 60

    cmanagerdclient configuration file 61

    manually stopping and starting 101

    renderd 67

    starting and stopping, Incinerator Resource  
        Manager 86

documentation

    library, on the Autodesk Web site 4

documentation, related 2

## G

- Gigabit Ethernet, function 8
- GigE switch
  - connecting Lustre Media Server, Incinerator Nodes 17
  - connecting workstations 21
- graphics driver, troubleshooting 98
- grounding hardware 13
- guidelines, hardware environment 12

## H

- hardware
  - environment guidelines 12
  - grounding 13
  - workflow for connecting 11

## I

- Incinerator
  - components 7
  - configurations, expanding 8
- Incinerator Node groups, connecting to 64
- Incinerator Nodes
  - BIOS 26
  - connecting 17
  - creating groups 76
  - function 7
  - grouping 75
  - groups, deleting 85
  - groups, modifying contents 82
  - groups, modifying owner or name 80
  - installing Incinerator software 51
  - installing renderd licenses 58
  - monitoring 70
- Incinerator Resource Manager
  - administrator permissions, modifying 94
  - daemons, starting and stopping 86
  - Incinerator Nodes, creating groups 76
  - Incinerator Nodes, deleting groups 85
  - Incinerator Nodes, grouping 75
  - Incinerator Nodes, modifying contents 82
  - Incinerator Nodes, modifying owner or name of groups 80
  - Incinerator Nodes, monitoring 70
  - logging in 69
  - Lustre Media Servers, monitoring 72
  - overview 67
  - rendering, monitoring 75

- starting 68

- starting and stopping the Lustre application 86

- user accounts 90
- user accounts, creating 90
- user accounts, deleting 93
- user accounts, modifying passwords 91
- user accounts, modifying rights 92
- workstations, monitoring 73

- Incinerator software installation workflow 49

- Incinerator, using in Lustre 62

- InfiniBand

- function 8
- log files 107
- management 105
- port statistics 105, 107

- InfiniBand switch

- connecting Lustre Media Server, Incinerator Node 17
- connecting workstations 21

- IP addressing, changing 103

## K

- KVM switch

- connecting keyboard, monitor, mouse 21
- connecting Lustre Media Server, Incinerator Nodes 17

## L

- license server

- creating the license file 56
- installing 56
- starting 57

- licensing

- background rendering 113
- creating the license server license file 56
- installing BrowseD license 58
- installing Incinerator Node licenses 58
- installing workstation licenses workstations 59
- license codes required 54
- requesting license codes 55
- starting the license server 57
- workflow 53

- lmhostid, obtaining 54

- log files

- daemon 102

- InfiniBand 107
- logical volume, assembling LUNs 43
- LUNs
  - assembling into logical volume 43
  - checking detection 41
  - checking partition type 42
- Lustre
  - Cluster menu 64
  - detecting Backburner Manager 111
  - monitoring 73
  - project management 63
  - real-time playback 63
  - starting 62
- Lustre Media Servers
  - BIOS 24
  - connecting 17
  - function 7
  - installing Incinerator software 50
  - monitoring 72
- Lustre workstation, function 7

## M

- monitor settings, troubleshooting 100
- monitor, troubleshooting 98

## N

- networking, changing IP addressing 103
- notation conventions 4
- NVIDIA driver
  - checking version or installing 98

## P

- PDF documentation, accessing 3
- playback
  - real-time in Incinerator 65
  - real-time with Incinerator 63
  - with Incinerator 63, 65
- port statistics, InfiniBand 105, 107
- power requirements 13
- projects, setting up for Incinerator 63

## Q

- QLogic BIOS 27

## R

- real-time playback 63

- real-time playback, troubleshooting 101
- renderd 67
  - licensing 58
  - log files 102
  - monitoring 70
- rendering
  - with BrowseD 115
- rendering, monitoring command line 75

## S

- services. See daemons
- shipment, checking hardware 12
- startup time
  - troubleshooting 97
- static electricity, avoiding damage 13
- storage
  - connecting and powering up 38
  - creating the XFS filesystem 46
  - workflow for configuring 37

## T

- troubleshooting
  - graphics driver and monitor 98
  - monitor settings 100
  - startup time 97
- troubleshooting real-time playback 101

## U

- user accounts
  - creating, Incinerator Resource Manager 90
  - deleting, Incinerator Resource Manager 93
  - Incinerator Resource Manager 90
  - modifying administrator permissions, Incinerator Resource Manager 94
  - modifying passwords, Incinerator Resource Manager 91
  - modifying rights, Incinerator Resource Manager 92

## W

- workflow
  - connecting hardware 11
  - installing Incinerator software 49
  - licensing 53
  - setting up background rendering 110
  - starting Lustre 62

- storage configuration 37
- workstations
  - BIOS 22
  - connecting 21
  - function 7
  - installing Incinerator software 51
  - installing licenses 59
  - monitoring 73

## X

- XFS filesystem 46