

**Autodesk®**  
Incinerator® 2009

# Installation and User Guide

© 2008 Autodesk, Inc. All rights reserved. Except as otherwise permitted by Autodesk, Inc., this publication, or parts thereof, may not be reproduced in any form, by any method, for any purpose.

Certain materials included in this publication are reprinted with the permission of the copyright holder.

Portions relating to ADOdb Copyright © 2000, 2001, 2002, 2003, 2004 John Lim. All rights reserved. Redistribution and use in source and binary forms, with or without modification, are permitted provided that the following conditions are met: Redistributions of source code must retain the above copyright notice, this list of conditions and the following disclaimer. Redistributions in binary form must reproduce the above copyright notice, this list of conditions and the following disclaimer in the documentation and/or other materials provided with the distribution. Neither the name of the John Lim nor the names of its contributors may be used to endorse or promote products derived from this software without specific prior written permission. **DISCLAIMER: THIS SOFTWARE IS PROVIDED BY THE COPYRIGHT HOLDERS AND CONTRIBUTORS "AS IS" AND ANY EXPRESS OR IMPLIED WARRANTIES, INCLUDING, BUT NOT LIMITED TO, THE IMPLIED WARRANTIES OF MERCHANTABILITY AND FITNESS FOR A PARTICULAR PURPOSE ARE DISCLAIMED. IN NO EVENT SHALL JOHN LIM OR CONTRIBUTORS BE LIABLE FOR ANY DIRECT, INDIRECT, INCIDENTAL, SPECIAL, EXEMPLARY, OR CONSEQUENTIAL DAMAGES (INCLUDING, BUT NOT LIMITED TO, PROCUREMENT OF SUBSTITUTE GOODS OR SERVICES; LOSS OF USE, DATA, OR PROFITS; OR BUSINESS INTERRUPTION HOWEVER CAUSED AND ON ANY THEORY OF LIABILITY, WHETHER IN CONTRACT, STRICT LIABILITY, OR TORT (INCLUDING NEGLIGENCE OR OTHERWISE) ARISING IN ANY WAY OUT OF THE USE OF THIS SOFTWARE, EVEN IF ADVISED OF THE POSSIBILITY OF SUCH DAMAGE.**

Portions relating to GetOpt Copyright © 1987, 1993, 1994. The Regents of the University of California. All rights reserved. Redistribution and use in source and binary forms, with or without modification, are permitted provided that the following conditions are met: 1. Redistributions of source code must retain the above copyright notice, this list of conditions and the following disclaimer. 2. Redistributions in binary form must reproduce the above copyright notice, this list of conditions and the following disclaimer in the documentation and/or other materials provided with the distribution. 3. All advertising materials mentioning features or use of this software must display the following acknowledgement: This product includes software developed by the University of California, Berkeley and its contributors. 4. Neither the name of the University nor the names of its contributors may be used to endorse or promote products derived from this software without specific prior written permission. **THIS SOFTWARE IS PROVIDED BY THE REGENTS AND CONTRIBUTORS "AS IS" AND ANY EXPRESS OR IMPLIED WARRANTIES, INCLUDING, BUT NOT LIMITED TO, THE IMPLIED WARRANTIES OF MERCHANTABILITY AND FITNESS FOR A PARTICULAR PURPOSE ARE DISCLAIMED. IN NO EVENT SHALL THE REGENTS OR CONTRIBUTORS BE LIABLE FOR ANY DIRECT, INDIRECT, INCIDENTAL, SPECIAL, EXEMPLARY, OR CONSEQUENTIAL DAMAGES (INCLUDING, BUT NOT LIMITED TO, PROCUREMENT OF SUBSTITUTE GOODS OR SERVICES; LOSS OF USE, DATA, OR PROFITS; OR BUSINESS INTERRUPTION) HOWEVER CAUSED AND ON ANY THEORY OF LIABILITY, WHETHER IN CONTRACT, STRICT LIABILITY, OR TORT (INCLUDING NEGLIGENCE OR OTHERWISE) ARISING IN ANY WAY OUT OF THE USE OF THIS SOFTWARE, EVEN IF ADVISED OF THE POSSIBILITY OF SUCH DAMAGE.**

Portions relating to GetOpt Copyright ©1999, 2000 Politecnico di Torino. All rights reserved. Redistribution and use in source and binary forms, with or without modification, are permitted provided that: (1) source code distributions retain the above copyright notice and this paragraph in its entirety, (2) distributions including binary code include the above copyright notice and this paragraph in its entirety in the documentation or other materials provided with the distribution, and (3) all advertising materials mentioning features or use of this software display the following acknowledgement: "This product includes software developed by the Politecnico di Torino, and its contributors." Neither the name of the University nor the names of its contributors may be used to endorse or promote products derived from this software without specific prior written permission. **THIS SOFTWARE IS PROVIDED "AS IS" AND WITHOUT ANY EXPRESS OR IMPLIED WARRANTIES, INCLUDING, WITHOUT LIMITATION, THE IMPLIED WARRANTIES OF MERCHANTABILITY AND FITNESS FOR A PARTICULAR PURPOSE.**

Portions relating to LibXML2 2.6.20 Copyright © 2005 Daniel Veillard. Permission is hereby granted, free of charge, to any person obtaining a copy of this software and associated documentation files (the "Software"), to deal in the Software without restriction, including without limitation the rights to use, copy, modify, merge, publish, distribute, sublicense, and/or sell copies of the Software, and to permit persons to whom the Software is furnished to do so, subject to the following conditions: The above copyright notice and this permission notice shall be included in all copies or substantial portions of the Software. **THE SOFTWARE IS PROVIDED "AS IS", WITHOUT WARRANTY OF ANY KIND, EXPRESS OR IMPLIED, INCLUDING BUT NOT LIMITED TO THE WARRANTIES OF MERCHANTABILITY, FITNESS FOR A PARTICULAR PURPOSE AND NONINFRINGEMENT. IN NO EVENT SHALL THE AUTHORS OR COPYRIGHT HOLDERS BE LIABLE FOR ANY CLAIM, DAMAGES OR OTHER LIABILITY, WHETHER IN AN ACTION OF CONTRACT, TORT OR OTHERWISE, ARISING FROM, OUT OF OR IN CONNECTION WITH THE SOFTWARE OR THE USE OR OTHER DEALINGS IN THE SOFTWARE.**

The following are registered trademarks or trademarks of Autodesk, Inc., in the USA and other countries: 3DEC (design/logo), 3December, 3December.com, 3ds Max, ADI, Alias, Alias (swirl design/logo), AliasStudio, AliasWavefront (design/logo), ATC, AUGI, AutoCAD, AutoCAD Learning Assistance, AutoCAD LT, AutoCAD Simulator, AutoCAD SQL Extension, AutoCAD SQL Interface, Autodesk, Autodesk Envision, Autodesk Insight, Autodesk Intent, Autodesk Inventor, Autodesk Map, Autodesk MapGuide, Autodesk Streamline, AutoLISP, AutoSnap, AutoSketch, AutoTrack, Backdraft, Built with ObjectARX (logo), Burn, Buzzsaw, CAiCE, Can You Imagine, Character Studio, Cinestream, Civil 3D, Cleaner, Cleaner Central, ClearScale, Colour Warper, Combustion, Communication Specification, Constructware, Content Explorer, Create>what's>Next> (design/logo), Dancing Baby (image), DesignCenter, Design Doctor, Designer's Toolkit, DesignKids, DesignProf, DesignServer, DesignStudio, DesignStudio (design/logo), Design Web Format, DWF, DWG, DWG (logo), DWG Extreme, DWG TrueConvert, DWG TrueView, DXF, Ecotect, Exposure, Extending the Design Team, FBX, Filmbbox, FMDesktop, Freewheel, GDx Driver, Gmax, Green Building Studio, Heads-up Design, Heidi, HumanIK, IDEA Server, i-drop, ImageModeler, iMOUT, Incinerator, Inventor, Inventor LT, Kaydara, Kaydara (design/logo), Kynapse, Kynogon, LocationLogic, Lustre, Matchmover, Maya, Mechanical Desktop, MotionBuilder, Movimento, Mudbox, NavisWorks, ObjectARX, ObjectDBX, Open Reality, Opticore, Opticore Opus, PolarSnap, PortfolioWall, Powered with Autodesk Technology, Productstream, ProjectPoint,

ProMaterials, RasterDWG, Reactor, RealDWG, Real-time Roto, REALVIZ, Recognize, Render Queue, Retimer,Reveal, Revit, Showcase, ShowMotion, SketchBook, SteeringWheels, Stitcher, StudioTools, Topobase, Toxik, TrustedDWG, ViewCube, Visual, Visual Construction, Visual Drainage, Visual Landscape, Visual Survey, Visual Toolbox, Visual LISP, Voice Reality, Volo, Vtour, Wiretap, and WiretapCentral.

#### Trademarks

The following are registered trademarks or trademarks of Autodesk Canada Co. in the USA and/or Canada and other countries: Backburner, Discreet, Fire, Flame, Flint, Frost, Inferno, Multi-Master Editing, River, Smoke, Sparks, Stone, and Wire.

All other brand names, product names or trademarks belong to their respective holders.

#### Disclaimer

THIS PUBLICATION AND THE INFORMATION CONTAINED HEREIN IS MADE AVAILABLE BY AUTODESK, INC. "AS IS." AUTODESK, INC. DISCLAIMS ALL WARRANTIES, EITHER EXPRESS OR IMPLIED, INCLUDING BUT NOT LIMITED TO ANY IMPLIED WARRANTIES OF MERCHANTABILITY OR FITNESS FOR A PARTICULAR PURPOSE REGARDING THESE MATERIALS.

Published by: Autodesk, Inc.  
111 McInnis Parkway  
San Rafael, CA 94903, USA

Title: Autodesk Incinerator 2009 Installation and User Guide  
Document Version: 1  
Date: August 01, 2009



# Contents

- Chapter 1 Introduction . . . . . 1**
  - About Autodesk Incinerator . . . . . 1
  - About this Guide . . . . . 1
    - Intended Audience . . . . . 2
    - Accessing PDF Documentation . . . . . 2
  - Notation Conventions . . . . . 2
  - Related Documentation . . . . . 2
  - Contacting Customer Support . . . . . 3
  
- Chapter 2 Incinerator Overview . . . . . 5**
  - Incinerator System Components . . . . . 5
  - Expanding Your System . . . . . 7
  - Connecting a Visual Effects and Finishing Workstation to Your System . . . . . 8
  
- Chapter 3 Installation Workflows . . . . . 9**
  - Overview . . . . . 9
  - Workflow for Upgrading the Software . . . . . 10
  - Workflow for Reinstalling from Scratch or Upgrading Linux . . . . . 10
  - Workflow for Connecting New Stone Direct Storage . . . . . 12
  
- Chapter 4 Connecting Components and Peripherals . . . . . 13**
  - Workflow for Connecting Components and Peripherals . . . . . 13
  - Verifying the Hardware Shipment . . . . . 14
  - Verifying the Hardware Environment . . . . . 14
    - Ensuring Proper Environmental Conditions . . . . . 14
    - Avoiding Damage from Static Electricity . . . . . 15
    - Grounding Hardware Components . . . . . 15
    - Ensuring Proper Power and Air Conditioning Requirements . . . . . 15
  - Installing Rack-Mount Hardware Components . . . . . 16
    - HP Components . . . . . 17

	IBM Components . . . . .	18
	Hardware Compatibility . . . . .	19
	Connecting the Lustre Workstation . . . . .	19
	Connecting Nodes and the Media Server . . . . .	20
	Connecting a Keyboard, Monitor, and Mouse to the KVM Switch . . . . .	23
	Verifying BIOS Versions and Settings . . . . .	23
	Workstation and Lustre Media Server BIOS . . . . .	23
	Incinerator Node BIOS . . . . .	23
	QLogic BIOS Settings . . . . .	25
<b>Chapter 5</b>	<b>Installing Linux and the DKU . . . . .</b>	<b>27</b>
	Do I Need to Reinstall Linux? . . . . .	27
	Choosing an Install Process . . . . .	28
	Centralized Install Process . . . . .	28
	Local Install Process . . . . .	28
	Linux Installation Workflow . . . . .	29
	Linux Post-Installation Tasks . . . . .	31
	Installing the DKU . . . . .	31
	Customizing Network Settings . . . . .	32
	Customizing Network Settings in a Centralized Install Process . . . . .	32
	Customizing Network Settings for a Single Component . . . . .	33
<b>Chapter 6</b>	<b>Configuring Storage . . . . .</b>	<b>35</b>
	Overview . . . . .	35
	Do I Need to Perform these Procedures? . . . . .	35
	Connecting to the RAID Controller for the First Time . . . . .	36
	Powering Up Your Storage . . . . .	36
	Connecting to the RAID Controllers . . . . .	36
	Creating Hardware LUNs . . . . .	37
	Rescanning New LUNs from the Host Operating System . . . . .	38
	Partitioning Disks or LUN devices as LVM-type Primary Partitions . . . . .	39
	Assembling the Disk or LUN Devices into a Logical Volume . . . . .	40
	Creating the XFS Filesystem on the LVM device . . . . .	42
	Creating a Mount Point and Mounting the Storage . . . . .	43
<b>Chapter 7</b>	<b>Installing Incinerator Software . . . . .</b>	<b>45</b>
	Workflow for Installing Incinerator Software . . . . .	45
	Copying the Application Software onto the Lustre Media Server . . . . .	46
	Installing the Lustre Media Server Software . . . . .	46
	Installing the Incinerator Node Software . . . . .	47
	Installing the Workstation Software . . . . .	47
<b>Chapter 8</b>	<b>Using the Incinerator Resource Manager . . . . .</b>	<b>49</b>
	Overview . . . . .	49
	Before You Begin . . . . .	50
	Starting the Resource Manager . . . . .	50
	Understanding the User Interface . . . . .	52
	Managing Node Groups . . . . .	52
	Creating Incinerator Node Groups . . . . .	53
	Modifying the Name or Owner of an Incinerator Node Group . . . . .	55
	Modifying the Nodes Assigned to an Incinerator Node Group . . . . .	56
	Deleting Incinerator Node Groups . . . . .	58
	Monitoring Incinerator Nodes . . . . .	59
	Monitoring Lustre Media Servers . . . . .	61
	Monitoring Lustre Workstations . . . . .	62
	Monitoring Command-Line Rendering . . . . .	64
	Stopping and Starting Incinerator Daemons . . . . .	64

	Deleting Duplicate Entries . . . . .	66
	Managing Resource Manager User Accounts . . . . .	67
	Creating a New User Account . . . . .	68
	Modifying User Accounts . . . . .	68
	Managing Permissions . . . . .	69
<b>Chapter 9</b>	<b>Licensing and Starting Incinerator . . . . .</b>	<b>71</b>
	Workflow for Licensing, Configuring, and Using Incinerator . . . . .	71
	Determining the License Codes You Require . . . . .	72
	Obtaining the lmstid Strings . . . . .	72
	Requesting Incinerator License Codes . . . . .	73
	Creating the License File for the License Server . . . . .	73
	Starting the License Server . . . . .	74
	Installing the BrowseD License on the Lustre Media Server . . . . .	74
	Installing Incinerator Node Licenses . . . . .	75
	Installing the Workstation License . . . . .	76
	Configuring Incinerator Daemons . . . . .	76
	init.config . . . . .	76
	cmanagerd.conf . . . . .	76
	cmanagerdclient.conf . . . . .	77
	Using Lustre with Incinerator . . . . .	78
	Starting Lustre on the Workstation . . . . .	78
	Setting Up Lustre Project Management for Incinerator . . . . .	78
	Using Incinerator for Real-Time Playback . . . . .	79
<b>Chapter 10</b>	<b>Troubleshooting Tips . . . . .</b>	<b>83</b>
	Resolving Common Problems . . . . .	83
	Shortening Startup Time for the Incinerator Lustre Media Server . . . . .	83
	Restoring the Workstation Graphics Driver and Monitor Settings . . . . .	84
	Troubleshooting Problems with Real-Time Playback . . . . .	84
	Stopping and Starting Incinerator Daemons Manually . . . . .	85
	Viewing Incinerator Daemon Log Files . . . . .	86
	Changing the IP Addressing Scheme . . . . .	86
	InfiniBand Management . . . . .	88
	Reviewing Port Statistics Using the InfiniView Web Monitor . . . . .	88
	Reviewing Statistics and Information for a Port . . . . .	89
	Generating InfiniBand Log Files for Support . . . . .	89
<b>Appendix A</b>	<b>Configuring Background Rendering . . . . .</b>	<b>91</b>
	About Background Rendering . . . . .	91
	Background Rendering Components . . . . .	92
	Workflow for Setting Up Background Rendering . . . . .	93
	Sharing the Storage for Read/Write Access from Background Render Nodes . . . . .	93
	Installing Backburner Manager and Backburner Web Monitor . . . . .	94
	Configuring Lustre to Detect Backburner Manager . . . . .	95
	Setting Up Render Nodes . . . . .	95
	Render Node Hardware and Software Requirements . . . . .	96
	Installing Linux on Render Nodes . . . . .	96
	Mounting the Storage on the Render Nodes . . . . .	97
	Installing and Configuring Burn for Lustre . . . . .	98
	Specifying the Background Rendering Path in Lustre . . . . .	101
<b>Appendix B</b>	<b>Software, Project, and User Configuration Files . . . . .</b>	<b>103</b>
	Configuration File Overview . . . . .	103
	System Settings . . . . .	104

**Index** . . . . . **109**

# Introduction

# 1

## Topics in this chapter:

- [About Autodesk Incinerator](#) on page 1
- [About this Guide](#) on page 1
- [Notation Conventions](#) on page 2
- [Related Documentation](#) on page 2
- [Contacting Customer Support](#) on page 3

## About Autodesk Incinerator

Autodesk® Incinerator® dramatically increases the power of real-time playback in Autodesk® Lustre®, the award-winning high-performance digital intermediate system for HD, 2K and 4K colour grading. Incinerator employs a unique and powerful data transfer architecture that enables “in-line” processing by several computers to allow the colourist to apply multiple selectives and effects while maintaining real-time playback at full native resolution. All of this power frees the colourist to find the perfect colour grade and effect while providing instant results and interactivity to the client during a session.

## About this Guide

This guide describes how to set up, manage, and troubleshoot Incinerator in your facility.

In most cases, hardware integration and software installation are done on delivery by an authorized technician, therefore some of the procedures in this guide may not be necessary. However, it is a good idea to read through all chapters to familiarize yourself with the configuration procedures for the following reasons:

- If you suspect your Incinerator system is malfunctioning due to loose connections or improperly configured devices, this guide helps you troubleshoot problems by providing information about properly configured systems.

- If you need to call Customer Support, information in this guide is useful because you are in a better position to provide diagnostic information.
- If you want to move your Incinerator system at any time, or upgrade certain hardware components, information in this guide is crucial.

The most up-to-date versions of all guides are available in PDF format from the Web at <http://www.autodesk.com/lustre-documentation>. For best results viewing and printing these PDF files, use Adobe® Acrobat® Reader™ 7 or later.

## Intended Audience

This guide assumes you have knowledge of Lustre, Linux® system administration, and computer hardware and networking. Do not attempt to carry out the procedures if you are unfamiliar with any of these subjects. Contact Customer Support should you require further assistance. See [Contacting Customer Support](#).

---

**NOTE** Most procedures described in this guide require root or super-user privileges.

---

## Accessing PDF Documentation

The complete documentation set is available in PDF (Portable Document Format) for online viewing and printing. You can access the PDF files from <http://www.autodesk.com/lustre-documentation>.

---

**NOTE** If you do not have Acrobat Reader, you can download a free copy from the Adobe Web site (<http://www.adobe.com>).

---

## Notation Conventions

A number of style conventions are used throughout your documentation. These conventions and examples of their use are shown as follows.

Convention	Example
Text that you enter in a command line or shell appears in Courier bold. Press the Enter key after each command.	<b>install rpm -qa</b>
Variable names appear in Courier, enclosed in angle brackets.	<filename>
Feedback from the command line or shell appears in Courier.	limit coredumpsize
Directory names, filenames, URLs, and command line utilities appear in italics.	<i>/usr/discreet</i>

## Related Documentation

Documentation for this release is installed with the product as PDF files and as an HTML help system, and is also available on the Autodesk web site at <http://www.autodesk.com/me-documentation>. From this page you can access the complete documentation library.

You should also refer to the product release notes for all late-breaking release information.

## Contacting Customer Support

For Autodesk Media and Entertainment Customer Support, visit <http://www.autodesk.com/support>.

Customer support is also available through your Autodesk reseller. To find a reseller near you, consult the reseller look-up database at <http://www.autodesk.com/resellers>.



# Incinerator Overview

# 2

## Topics in this chapter:

- [Incinerator System Components](#) on page 5
- [Expanding Your System](#) on page 7
- [Connecting a Visual Effects and Finishing Workstation to Your System](#) on page 8

## Incinerator System Components

The core Incinerator system consists of the following components:

**Lustre workstation** The Lustre workstation is a Linux workstation running either as a Master Station or a Lustre Station. From the Master Station, colorists apply grades and effects to shots and play them back in real-time. The Lustre Station is used to perform tasks that do not require the direct intervention or supervision of the colorist. It is not used to apply effects or play those effects back in real time.

In an Incinerator system no storage is directly attached to the Lustre workstation. All storage is attached to the Lustre Media Server.

The currently supported hardware platforms for Lustre workstations are:

- HP Z800
- HP xw8600
- HP xw8400
- IBM® Z Pro 6223

**Incinerator Nodes** The Incinerator nodes process frames inline so that they can be played back on the workstation.

The Incinerator nodes receive requests from the workstation to process selected frames. The Incinerator nodes send requests for those frames to the Lustre Media Server. After the Incinerator nodes process the frames, they send them back to the workstation for real-time playback.

You can also use the Incinerator nodes to perform background rendering over the InfiniBand® network using Burn™ for Lustre. For information on setting up background rendering for Lustre, refer to [Configuring Background Rendering](#) on page 91.

The currently supported hardware platforms for Incinerator nodes are:

- HP ProLiant DL160se G6
- HP ProLiant DL160 G5
- HP ProLiant DL140 G3
- IBM® eServer™ x336

**Lustre Media Server** The Lustre Media Server is the gateway to all the storage devices attached to it. It manages requests for frames and can store other project data.

The currently supported hardware platforms for Incinerator nodes are:

- HP Z800
- HP xw8600
- HP xw9400
- IBM eServer x346

Communication between these devices is carried over two networks. The private Incinerator Gigabit Ethernet (GigE) network manages control data. The high-speed InfiniBand network handles the transfer of frames to ensure real-time playback.

The following illustration demonstrates how the core components are connected.

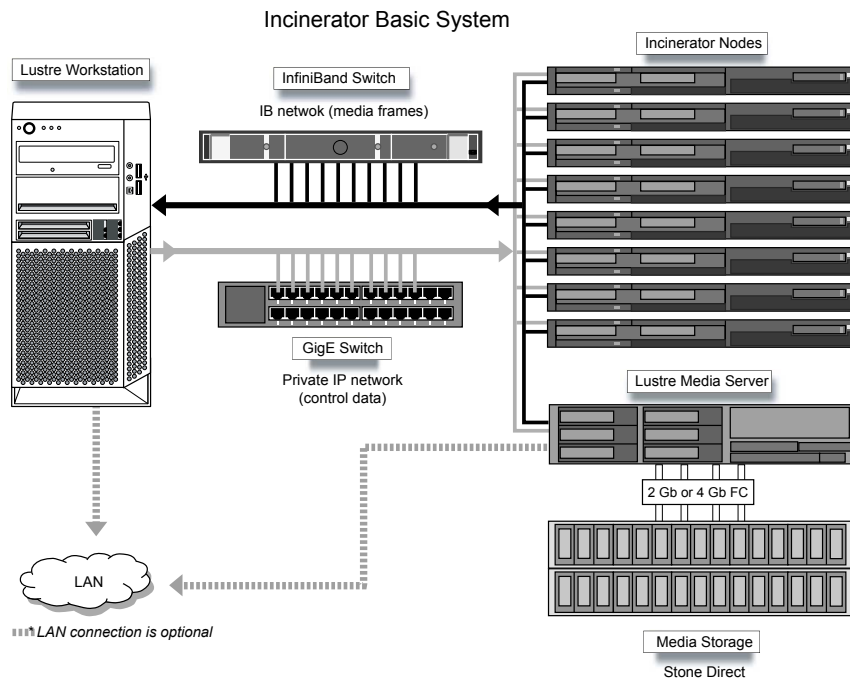

**NOTE** A 4-loop connection to storage from the Lustre Media Server is illustrated. Both 2-loop and 4-loop connections are supported.

## Expanding Your System

You can expand your system to include additional workstations, Incinerator Nodes, and storage. The following illustration demonstrates how you can expand your system.

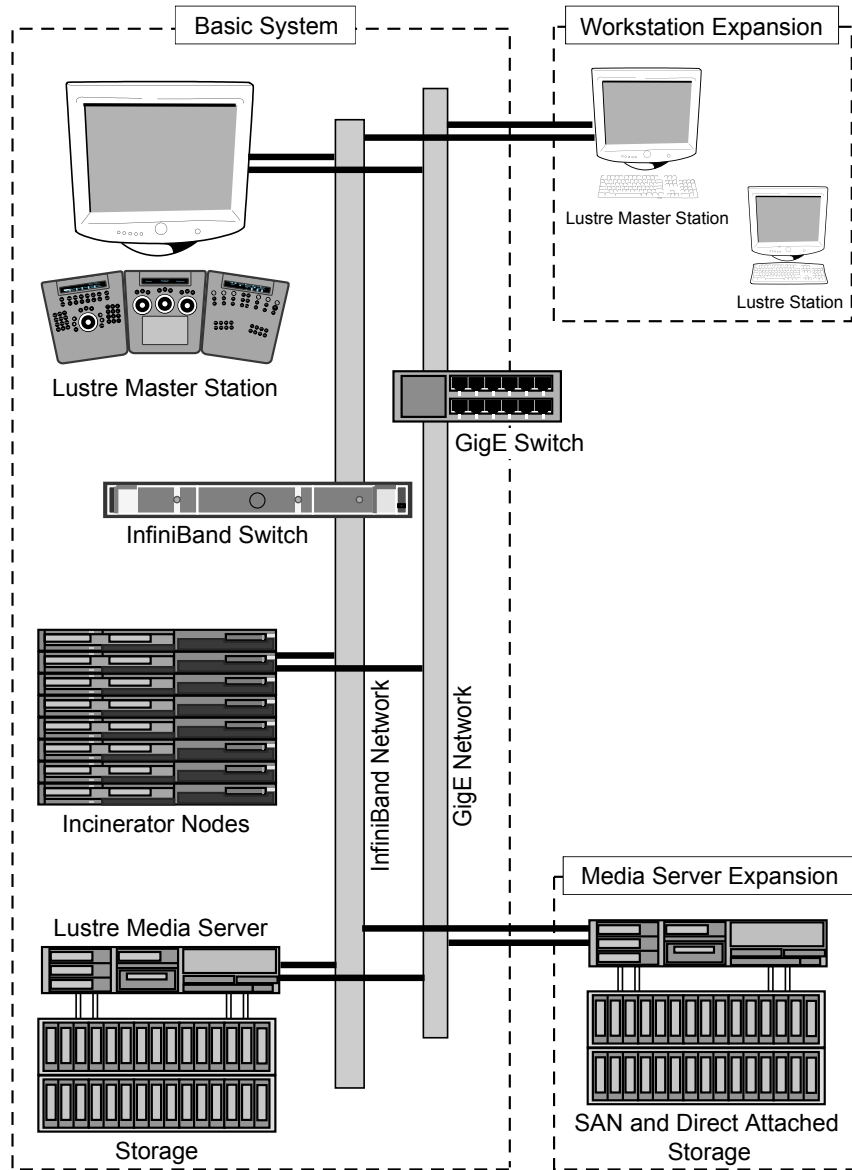

**NOTE** In a configuration with more than one Lustre Media Server, it is important to understand that Lustre can only connect to a single Lustre Media Server at a time; all read and write paths must point to the same Lustre Media Server. You cannot, for example, simultaneously read from one Lustre Media Server and write to another.

# Connecting a Visual Effects and Finishing Workstation to Your System

You can connect a Visual Effects and Finishing workstation (for example a workstation running Autodesk® Flame® or Autodesk® Smoke®) to an Incinerator configuration. The workstation must be on the same Gigabit Ethernet (GigE) and / or InfiniBand (IB) network as the Lustre workstation. This makes it possible to read/write frames from the storage connected to the Visual Effects and Finishing workstation in the following circumstances:

- If the Lustre Media Server and the Visual Effects and Finishing workstation are connected to the same Storage Area Network (SAN), you can use Autodesk Wiretap path translation to make the frames available through the Visual Effects and Finishing workstation on that filesystem to Incinerator. This configuration supports inline rendering and real-time playback as long as the SAN volume can accommodate that level of performance.
- If the Visual Effects and Finishing workstation is attached to a Stone Direct framestore, it is possible to read/write frames on that filesystem using Autodesk Wiretap over the Gigabit Ethernet (GigE) and / or IB network. Real-time playback and inline rendering are not supported in this configuration.

Refer to the latest *Autodesk Lustre User Guide* for more information on these configurations. Also check the latest *Autodesk Lustre Release Notes* for any late-breaking information on these configurations.

# Installation Workflows

# 3

## Topics in this chapter:

- [Overview](#) on page 9
- [Workflow for Upgrading the Software](#) on page 10
- [Workflow for Reinstalling from Scratch or Upgrading Linux](#) on page 10
- [Workflow for Connecting New Stone Direct Storage](#) on page 12

## Overview

Your system is shipped with the operating system and the software already installed.

This chapter highlights three common installation workflows that you may need to perform, and lists the documentation relevant to each.

---

**NOTE** You should always identify and download the relevant documentation and software installation packages before proceeding with any installation procedures. Links to the software installation packages are provided in the release announcement you received from Autodesk.

---

- [Workflow for Upgrading the Software](#) on page 10
- [Workflow for Reinstalling from Scratch or Upgrading Linux](#) on page 10
- [Workflow for Connecting New Stone Direct Storage](#) on page 12

---

**NOTE** Each step in these workflows points to a section in this document for detailed instructions. The sections are in sequence, so once you finish performing the steps in one section, you do not need to come back to the high-level workflow, you can just continue to the next section for further instructions.

---

For details on the workstation hardware setup, it is recommended that you visit [www.autodesk.com/lustre-documentation](http://www.autodesk.com/lustre-documentation), select your application and version, and download the *Hardware Setup Guide* for your workstation model.

## Workflow for Upgrading the Software

Follow this workflow to to upgrade your software to a new version, service pack, or extension without reconfiguring your hardware or upgrading your operating system.

To determine whether you need to upgrade Linux for a new software version or hardware platform, see [Do I Need to Reinstall Linux?](#) on page 27. If you do need to upgrade Linux, follow the steps in the [Workflow for Reinstalling from Scratch or Upgrading Linux](#) on page 10 rather than this workflow.

### To upgrade the software:

- 1 Gather the necessary materials and documentation for your installation.

---

**NOTE** Make sure you read the Release Notes for the software version or service pack you plan to install. The Release Notes contain important procedures that you might need to perform **before** upgrading your software, as well as information on supported hardware, required system memory, BIOS version, Linux distribution, DKU version and AJA OEM-2K firmware version.

---

To download the latest Release Notes, go to [www.autodesk.com/lustre-documentation](http://www.autodesk.com/lustre-documentation), then select the version or service pack you plan to install.

- 2 Make sure the hardware meets all the system requirements for the new software version or service pack, as specified in the Release Notes for the version you plan to install.
- 3 Upgrade the Discreet® Kernel Utilities (DKU) to the required version on the Lustre workstation, Lustre Media Server and on each Incinerator Node. Refer to the latest Release Notes for the required firmware version and for update instructions. DKU update instructions are also available in [Installing the DKU](#) on page 31.
- 4 Update the AJA OEM-2K card firmware on the Lustre workstation if necessary. Refer to the latest Release Notes for the required firmware version and for update instructions. .
- 5 Install the software on the Lustre workstation, Lustre Media Server and on the Incinerator Nodes. See [Installing Incinerator Software](#) on page 45.
- 6 License your software, and start it for the first time. See [Licensing and Starting Incinerator](#) on page 71.

---

**NOTE** Re-licensing is not necessary if you are upgrading to a service pack of the same software version or extension.

---

## Workflow for Reinstalling from Scratch or Upgrading Linux

Follow this workflow when you need to completely rebuild your system: from cross-connecting the hardware peripherals and storage arrays, to installing the operating system, and installing, licensing, and configuring the software components.

Most of this workflow also applies when you need to upgrade the operating system without changing your hardware or storage setup. A new distribution of Linux may sometimes be required for a new version or service pack of the software, or for newer hardware platforms. To determine whether you need to upgrade Linux for a new application version or hardware platform, see [Do I Need to Reinstall Linux?](#) on page 27.

## To reinstall your system from scratch or upgrade Linux:

- 1 Gather the necessary materials and documentation for your installation.

---

**NOTE** Make sure you read the Release Notes for the version or service pack you plan to install. The Release Notes contain important procedures that you might need to perform **before** upgrading your software, as well as information on supported hardware, required system memory, BIOS version, Linux distribution, DKU version and AJA OEM-2K firmware version (for the Lustre workstation).

---

To download the latest Release Notes for your application version, go to [www.autodesk.com/lustre-documentation](http://www.autodesk.com/lustre-documentation), then select the version or service pack you plan to install.

- 2 Make sure the hardware meets all the system requirements specified in the Release Notes for the version you plan to install.
- 3 If you are reinstalling your hardware perform the following tasks:

---

**NOTE** Instructions and wiring diagrams for each of these steps can be found in [Connecting Components and Peripherals](#) on page 13 and in the *Hardware Setup Guide* for the Lustre workstation and Lustre Media Server hardware platform.

---

- Verify your hardware shipment, and make sure your facility meets the documented power and air conditioning requirements for the hardware components.
  - Install the hardware components in the rack.
  - Connect all peripherals (mouse, keyboard, , graphics monitor, house network) to the proper ports on the workstation, Lustre Media Server and Incinerator Nodes.
  - Connect the Control Surface to the proper ethernet and USB ports on the workstation.
  - Connect the Lustre workstation, the Lustre Media Server and all Incinerator nodes to the private GigE network and to the InfiniBand® network.
  - Connect a VTR and a broadcast monitor to your workstation.
  - Connect and configure the audio hardware for your workstation.
  - Connect your storage arrays to the Lustre Media Server, but **DO NOT** power them on before having installed Linux, to prevent the Linux installer from attempting to format the arrays and use them as system drives.
- 4 If necessary, update and configure the BIOS of your workstation, Lustre Media Server and Incinerator nodes. See the *Hardware Setup Guide* for your workstation and Lustre Media Server, and [Verifying BIOS Versions and Settings](#) on page 23 for Incinerator Nodes..

---

**NOTE** The BIOS settings must be properly configured **before** installing Linux.

---

- 5 Install the required Autodesk distribution of Red Hat Enterprise Linux. See [Installing Linux and the DKU](#) on page 27.
- 6 Install the required version of the Discreet Kernel Utility (DKU). Refer to the latest Release Notes for the required version and for update instructions. DKU update instructions are also available in [Installing the DKU](#) on page 31.
- 7 Update the AJA OEM-2K card firmware on your workstation if necessary. Refer to the latest Release Notes for the required firmware version and for update instructions.

- 8 If you are using a new Stone® Direct storage array, configure the RAID volumes, mount the storage, and format it. See [Configuring Storage](#) on page 35 for LUN creation instructions and XFS filesystem creation instructions.
- 9 Install the software on the Lustre workstation, Lustre Media Server and on the Incinerator Nodes. See [Installing Incinerator Software](#) on page 45.
- 10 Group your Incinerator nodes into groups (clusters). See [Using the Incinerator Resource Manager](#) on page 49.
- 11 License your software, and start it for the first time. See [Licensing and Starting Incinerator](#) on page 71.

---

**NOTE** Re-licensing is not necessary if you are upgrading to a service pack of the same software version or extension.

---

## Workflow for Connecting New Stone Direct Storage

Follow this workflow when you need to rebuild your Stone Direct storage array. For instance, this may be required when you purchase supplementary storage enclosures to expand available disk space.

---

**NOTE** You do not need to reinstall or re-license the software after changing your storage configuration.

---

### To connect new or expanded Stone Direct storage:

- 1 Connect your storage enclosures to the Lustre Media Server. See [Connecting Media Storage](#).
- 2 Configure the RAID volumes and mount the storage. See the *Hardware Setup Guide* for your Lustre Media Server platform for instructions.
- 3 Your new storage is now ready to use.

# Connecting Components and Peripherals

# 4

## Topics in this chapter:

- [Workflow for Connecting Components and Peripherals](#) on page 13
- [Verifying the Hardware Shipment](#) on page 14
- [Verifying the Hardware Environment](#) on page 14
- [Installing Rack-Mount Hardware Components](#) on page 16
- [Hardware Compatibility](#) on page 19
- [Connecting the Lustre Workstation](#) on page 19
- [Connecting Nodes and the Media Server](#) on page 20
- [Connecting a Keyboard, Monitor, and Mouse to the KVM Switch](#) on page 23
- [Verifying BIOS Versions and Settings](#) on page 23

## Workflow for Connecting Components and Peripherals

The recommended steps for connecting Incinerator components are in the table that follows.

Step:	Refer to:
1. Verify the Incinerator hardware shipment.	<a href="#">Verifying the Hardware Shipment</a> on page 14.
2. Ensure you have the proper environment for your Incinerator system.	<a href="#">Verifying the Hardware Environment</a> on page 14.
3. Install the Lustre Media Server, Incinerator nodes, KVM (keyboard, video, and mouse) switch, InfiniBand switch, and Gigabit Ethernet (GigE) switch in the rack you selected.	<a href="#">Installing Rack-Mount Hardware Components</a> on page 16.

Step:	Refer to:
4. Set up the workstation and connect it to the InfiniBand switch and GigE switch.	<a href="#">Connecting the Lustre Workstation</a> on page 19.
5. Connect the Incinerator Nodes and Lustre Media Server to the KVM switch, InfiniBand switch, and GigE switch.	<a href="#">Connecting Nodes and the Media Server</a> on page 20.
6. Connect a keyboard, monitor, and mouse to the KVM switch so that you can log in to the Lustre Media Server and Incinerator Nodes directly.	<a href="#">Connecting a Keyboard, Monitor, and Mouse to the KVM Switch</a> on page 23.
7. After you install Linux, verify the BIOS version and settings of the hardware components. The BIOS of each of your hardware components is set by Autodesk prior to shipping.	<a href="#">Verifying BIOS Versions and Settings</a> on page 23.

## Verifying the Hardware Shipment

When you receive the shipment containing your Incinerator system, check all boxes for dents or other markings that may indicate damage during transport. If you suspect a component is damaged, carefully inspect it before setting up the system. If you receive a damaged component, call Customer Support. See [Contacting Customer Support](#) on page 3.

Also check the packing slip to ensure that you have received all the necessary items.

## Verifying the Hardware Environment

Hardware configuration should only be performed by an experienced hardware integrator familiar with the Linux operating system, workstations, and peripherals associated with professional high-performance video and film post production.

Your Incinerator system consists of high-performance hardware that requires an environment suited to its operational needs, as described in the following sections.

## Ensuring Proper Environmental Conditions

Use the following guidelines to ensure proper environmental conditions for all hardware components:

- Make sure the rack in which hardware components are installed is open or ventilated. Follow the ventilation specifications that apply to your system.
- Place all components in an air-conditioned environment. All hardware components generate heat and must be kept cool. Follow the air-conditioning specifications that apply to your system. For more information about the cooling requirements of your system, see [Ensuring Proper Power and Air Conditioning Requirements](#) on page 15.
- Keep all hardware components in a clean, dust-free location.
- Minimize vibration and humidity.
- Do not block the vents on the component housing.
- Do not drape anything, such as a jacket or a blanket, over hardware components.
- Minimize electromagnetic noise by separating digital data, power, and analog audio cables and running them in different cable ducts.

# Avoiding Damage from Static Electricity

When installing any hardware equipment, take the following precautions to prevent damage to sensitive components from static discharge:

- Make sure power is turned off on the component you are working on. It is a good idea to unplug components until all other connections are configured.
- Always wear a grounded static wrist strap. Attach the strap's alligator clip to any grounded metal surface on the chassis of the component that you are working on.
- Do not handle any components unnecessarily, particularly boards and cards that slide in and out of slots on their parent hardware components.

## Grounding Hardware Components

It is important to properly ground any audio components used with Incinerator to avoid ground loops and humming. To ensure audio components are properly grounded, use the XLR-3 cables. Using any other cables may cause humming in the system.

## Ensuring Proper Power and Air Conditioning Requirements

This section summarizes the peak (at startup) power consumption and heat propagation of the components in the core Incinerator system. An example of an appropriate electrical circuit distribution for Incinerator is also provided. For detailed specifications on each hardware component (including noise output), see the documentation provided by the manufacturer.

### HP Components

Consult the following table if your Incinerator system uses HP® components.

Component	Quantity	Amps (120V)	Amps (240V)	Watts	Heat (BTUs)
HP Z800 (Lustre Media Server)	1	3.8	1.9	456	1556
HP xw8600 (Lustre Media Server)	1	3.5	1.5	420	1433
HP xw9400 (Lustre Media Server)	1	3	1.5	360	1228
HP ProLiant DL160se G6 Server (Incinerator Nodes)	8	2.27	2	2179	7435
HP ProLiant DL160 G5 Server (Incinerator Nodes)	8	2.27	2	2179	7435
HP ProLiant DL160 G5 Server (Incinerator Nodes)	8	3	1.5	2880	9827
HP ProLiant DL140 G3 Server (Incinerator Nodes)	8	2.27	2	2179	7435
HP Z800 (Workstation)	1	3.8	1.9	456	1556
HP xw8600 (Workstation)	1	3.5	1.5	420	1433
HP xw8400 (Workstation)	1	3.5	1.75	420	1433
InfiniBand switch	1	2	1	240	819
GigE switch	1	1	.5	120	409
KVM switch	1	1	.5	120	409
XR Storage chassis	1	5.5	2.75	660	2252
XE Storage chassis (expansion chassis)	1	5.5	2.75	660	2252

## IBM Components

Consult the following table if your Incinerator system uses IBM components.

Component	Quantity	Amps (120V)	Amps (240V)	Watts	Heat (BTUs)
IBM eServer x346 (Lustre Media Server)	1	4	2	480	1638
IBM eServer x336 (Incinerator Nodes)	8	3	1.5	2880	9829
IBM ZPro 6223 (Workstation)	1	7	3.5	840	2866
InfiniBand switch	1	2	1	240	819
GigE switch	1	1	.5	120	409
KVM switch	1	1	.5	120	409
Storage chassis (XR/XE)	2	5.5	2.75	1320	4503
			TOTAL	7080	20473

**NOTE** If you are using IR storage, two chassis produce 3,686 BTUs (each chassis requires 4.5 120V Amps or 2.25 240V Amps). Substitute this BTU value for the one provided for the XR/XE storage, and recalculate the total BTUs produced by your Incinerator system.

### Example Circuit Layout

Based on the requirements provided above for IBM and HP components, in North America you need four 120V, 15A circuits to power the Incinerator components in the core system. See the following table for a suggestion on how to split the components between four 120V circuits.

Circuit	Components
1	4 Incinerator Nodes
2	4 Incinerator Nodes
3	Storage, InfiniBand switch, GigE switch, KVM switch
4	Workstation, Lustre Media Server, and monitors

For other locations around the world, use the number of amps provided by your power supply and the amps required by the components to determine how many circuits you need.

The Incinerator system components produce almost 20,000 BTUs of heat. You must have a climate control system with the capacity to maintain the temperature of these components while they are all operating.

## Installing Rack-Mount Hardware Components

You need sufficient space in your rack to install the Lustre Media Server, Incinerator Nodes, a KVM switch, an InfiniBand switch, and a GigE switch. The form factor units of these components are provided below, along with an example of one way to rack-mount the components.

## HP Components

Consult the following table if your Incinerator system uses HP components. Consult the illustration that follows the table for an example of how to organize the components in the rack.

Component	Quantity	Form Factor	Required Rack Space
HP Z800 (Lustre Media Server)	1	5U	5U
HP xw8600 (Lustre Media Server)	1	5U	5U
HP xw9400 (Lustre Media Server)	1	5U	5U
HP ProLiant DL160se G6 Server	8	1U	1U
HP ProLiant DL160 G5 Server	8	1U	8U
HP ProLiant DL140 G3 Server (Incinerator Nodes)	8	1U	8U
HP Z800 (Workstation)	1	5U	5U
HP xw8600 (Workstation)	1	5U	5U
HP xw8400 (Workstation)	1	5U	5U
SilverStorm™ 9024 InfiniBand switch	1	1U	1U
NETGEAR® 24-Port GigE switch	1	1U	1U
Belkin® 16-Port KVM Switch	1	2U	2U
Storage chassis (XR/XE)	2	2U	4U
AJA Breakout Box (for HP xw8600 and HP Z800)	1	1U	1U
DVS Breakout Box (for HP xw8400)	1	1U	1U
		TOTAL	27U

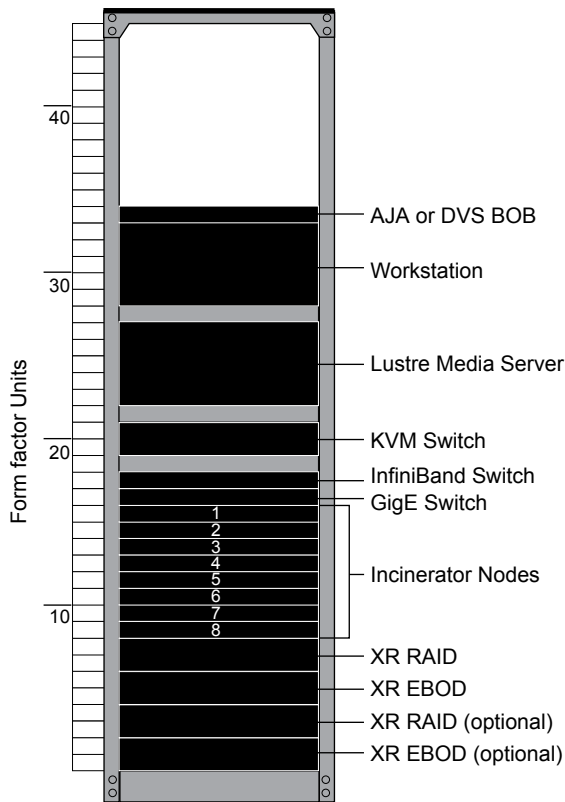

## IBM Components

Consult the following table if your Incinerator system uses IBM components. Consult the illustration that follows the table for an example of how you can organize the components in the rack.

Component	Quantity	Form Factor	Required Rack Space
IBM eServer x346 (Lustre Media Server)	1	2U	2U
IBM eServer x336 (Incinerator Node)	8	1U	8U
IBM ZPro 6223 (Workstation)	1	5U	5U
SilverStorm 9024 InfiniBand switch	1	1U	1U
NETGEAR 24-Port GigE switch	1	1U	1U
Belkin 16-Port KVM Switch	1	2U	2U
Storage chassis (IR)	2	3U	6U
DVS Breakout Box	1	1U	1U
		TOTAL	26U

**NOTE** If you are using IR storage, each storage chassis has a form factor of 3U, thus the required rack space for two of these chassis is 6U. Substitute this value for the one provided for the XR/XE storage, and recalculate the total rack space required for your Incinerator system.

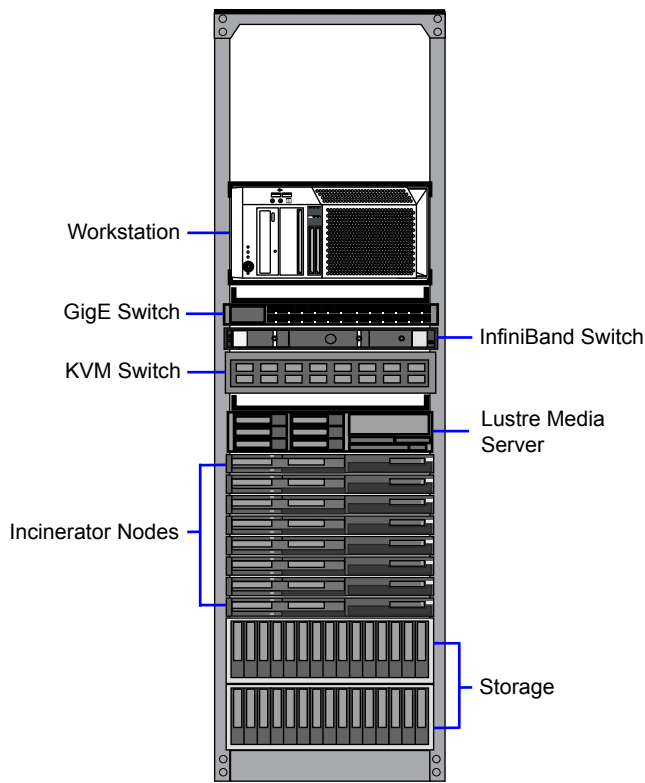

For detailed instructions on installing the components in the rack mount, see the documentation provided by the manufacturer.

## Hardware Compatibility

Before you create your Incinerator network, review the following table to make sure your Lustre Workstation, Lustre Media Server and Incinerator node hardware platforms are compatible with each other.

Lustre Workstation	Lustre Media Server	Incinerator Nodes
HP Z800	HP Z800	HP DL160se G6
HP xw8600	HP xw8600	HP DL160G5
HP xw8400	HP xw9400	HP DL160G5 HP DL140 G3
IBM Z Pro 6223	IBM eServer x346	IBM eServer x336

## Connecting the Lustre Workstation

Connecting the workstation requires that you first connect all peripherals to the workstation, and then connect the workstation to the Incinerator GigE and InfiniBand networks.

Refer to the *Hardware Setup Guide* for your workstation for diagrams illustrating the following tasks:

- Connecting the keyboard, mouse, and monitor
- Connecting the calibration device

- Connecting control surface
- Connecting video I/O components
- Connecting high-speed data link (HSDL) devices
- Connecting the correct port of the InfiniBand card to the InfiniBand switch.
- Connecting the correct onboard ethernet port to the GigE switch.
- Connecting a supplementary GigE port to your facility's house network, if necessary.

---

**WARNING** Remember to disconnect all devices from the supplementary GigE ports on the card during the installation of the Incinerator and Lustre software.

---

## Connecting Nodes and the Media Server

After you install the components in the rack, you are ready to connect the Incinerator nodes and Lustre Media Server to the KVM, InfiniBand, and GigE switches.

### Incinerator Nodes Wiring Diagrams

Use the following diagrams as a reference for the Incinerator Node connections.

#### HP DL160se G6 Incinerator Node

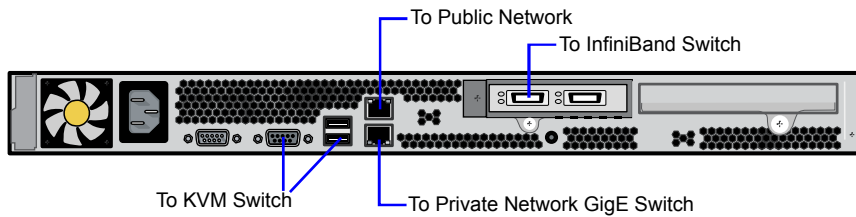

#### HP DL160 G5 Incinerator Node

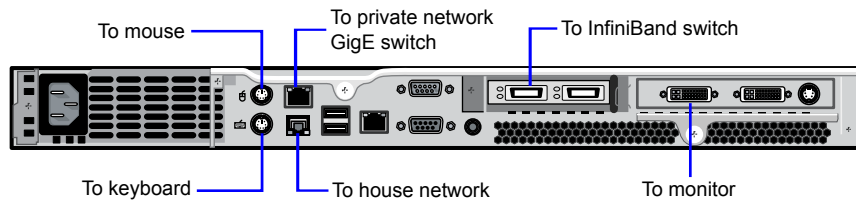

#### HP DL140 Incinerator Node

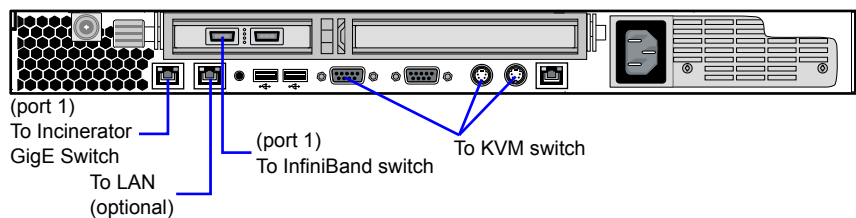

### IBM x336 Incinerator Node

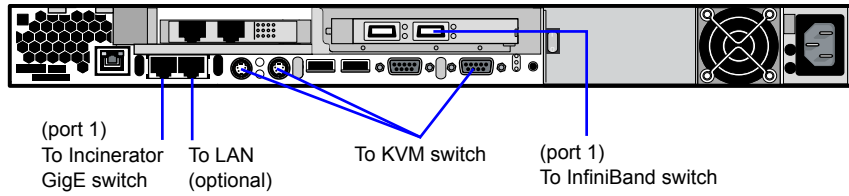

### Lustre Media Server Wiring Diagrams

Use the following diagrams as a reference for the Lustre Media Server connections.

#### HP Z800 Lustre Media Server

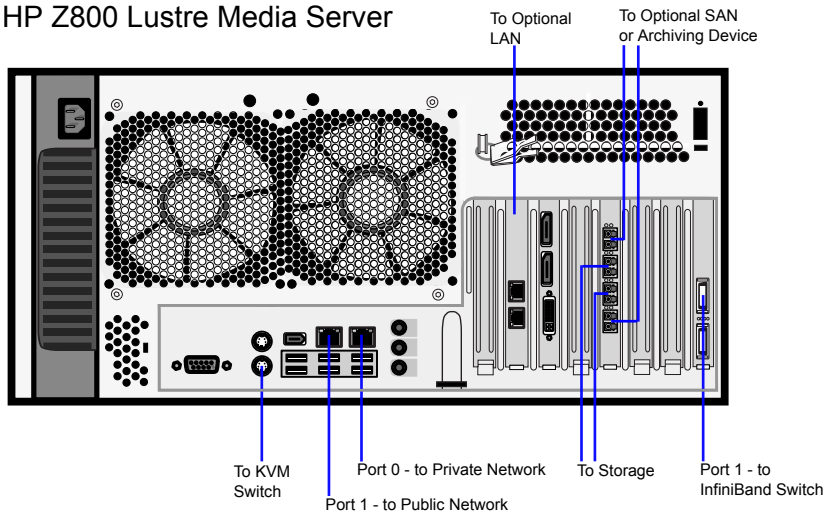

#### HP xw8600 Lustre Media Server

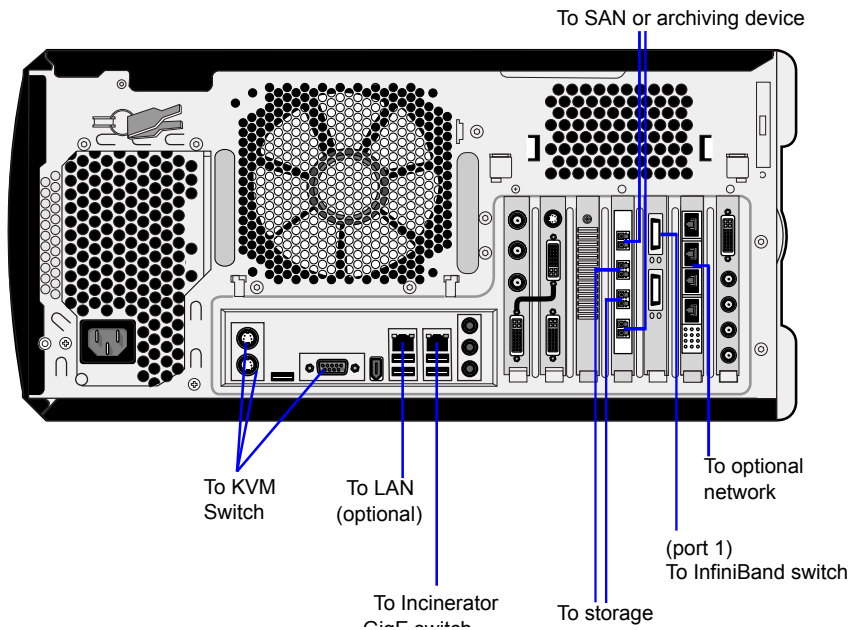

## HP xw9400 Lustre Media Server

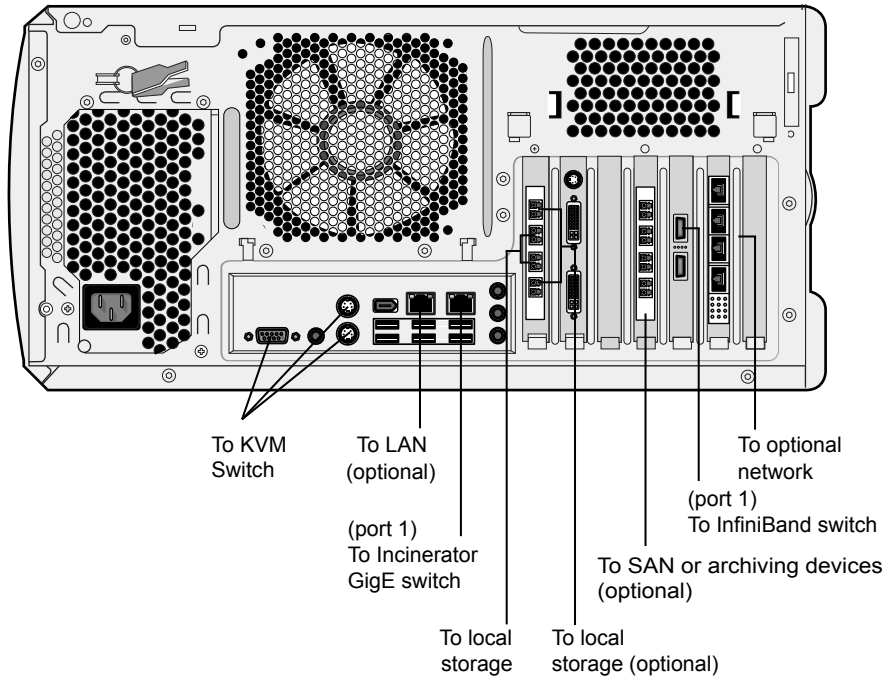

## IBM x346 Lustre Media Server

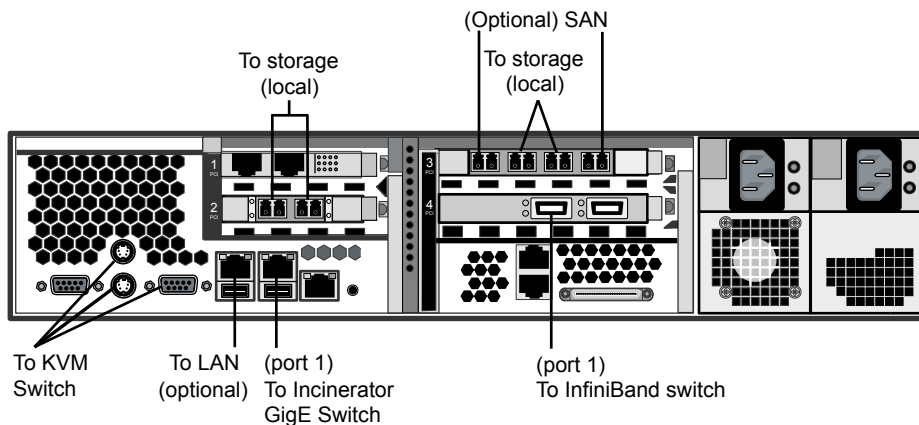

### To connect the Incinerator Nodes and the Lustre Media Server to the Incinerator network:

- 1 Connect the Incinerator Nodes and the Lustre Media Server to the KVM switch using the cables provided. Because the cables for the KVM switch have three connectors, it is best to connect the Lustre Media Server and nodes to the KVM switch first. You can more easily get the InfiniBand and GigE cables around the KVM cables than the other way around. Connect the nodes to the KVM switch in sequence. Consider connecting the Lustre Media Server to the last port on the switch.
- 2 On the Incinerator Nodes and Lustre Media Server, connect port 1 of the InfiniBand card to the InfiniBand switch. Refer to the appropriate diagram above for the location of port 1 on each component. The position of port 1 of the InfiniBand card is not identical on all components. Connect the nodes to the InfiniBand switch in sequence so that you can easily match their IP address to their position.

---

**WARNING** Do not connect the supplementary GigE ports on the cards to the Incinerator GigE switch. Always connect port 1 of the onboard network interface to the Incinerator GigE switch.

---

- 3 On the Incinerator Nodes and Lustre Media Server, connect port 1 of the onboard network interface to the GigE switch. Refer to the appropriate diagram above for the location of port 1 on each component. The position of port 1 of the onboard network interface is not identical on all components. Connect the nodes to the GigE switch in sequence so that you can easily match their IP address to their position.

## Connecting a Keyboard, Monitor, and Mouse to the KVM Switch

You must connect a keyboard, monitor, and mouse to the KVM switch so that you can manage the Incinerator nodes and Lustre Media Server from one location. With the KVM switch, you can log in directly to each component.

It is not necessary to connect the workstation to the KVM switch because it has its own keyboard, monitor, and mouse. You can log in remotely to the workstation from any component on the Incinerator network.

---

**NOTE** Unlike older nodes, HP ProLiant DL160se G6 nodes do not have PS/2 keyboard and mouse ports. Use an USB KVM switch with these nodes.

---

## Verifying BIOS Versions and Settings

Autodesk configures the BIOS of all components prior to shipping. You should not normally need to adjust these settings. BIOS settings for Incinerator Nodes, and QLogic™ fibre channel adapter are provided here for informational purposes.

---

**NOTE** The ATTO fibre channel adapter does not require specific BIOS settings. Settings for this adapter are defined in the *modprobe.conf* file.

---

## Workstation and Lustre Media Server BIOS

For information on BIOS versions and BIOS settings for Lustre workstations and Lustre Media Server hardware platforms, see the *Hardware Setup Guide* for the respective platform. The BIOS version and settings are the same, whether the platform is used as a workstation or as a Lustre Media Server.

## Incinerator Node BIOS

This section provides the latest supported BIOS version and the recommended BIOS settings for the HP DL160se G6, HP DL160 G5, HP DL140, and IBM eServer x336 Incinerator Nodes.

The BIOS update packages for each system are in the *Utils/BIOS* subdirectory of the DKU installation directory. Consult the *README* file inside the BIOS directory for instructions on updating the BIOS of your Incinerator node.

---

**TIP** While configuring BIOS settings, also verify that the node system date and time are correct, and adjust them if necessary.

---

## HP DL160se G6 BIOS Settings

The current certified system BIOS version for the HP DL160se G6 system is **06/10/2009**. The table below lists the correct BIOS settings for this system. Items not listed are set to their factory default.

To check the BIOS settings of the node, reboot the node, and when the boot process starts, press **F10** to enter the system BIOS and examine the settings.

BIOS Menu	Item	Value
Advanced	Power Efficiency Mode	Custom
Advanced, CPU Configuration	Intel HT Technology	Enabled
	Intel Speed Step Tech	Disabled
Advanced, CPU Bridge Configuration	QPI Links Speed	Full-Speed
	QPI L0s and L1	Disabled
	Memory Speed with 2PPC	1333MHz
	Advanced Memory Protection	Independent
	Node Interleaving	Enabled
Advanced, SATA Configuration	SATA#1 Controller Mode	AHCI
Advanced, PCI Configuration	Embedded VGA Control	Auto-Detect
	Embedded NIC Port 1 PXE	Disabled
Advanced, PCI Express Configuration	Active State Power Management	Disabled
	PCI Express Gen2	Gen2
Boot Settings, Boot Settings Configuration	Quiet Boot	Disabled
Boot Settings, Standard Boot Order	1st Boot Device	CD/DVD
	2nd Boot Device	Hard Drive

## HP DL160 G5 BIOS Settings

The current certified system BIOS version for the HP DL160 G5 system is **04/09/2008**. The table below lists the correct BIOS settings for this system. Items not listed are set to their factory default.

To check the BIOS settings of the node, reboot the node, and when the boot process starts, press **F10** to enter the system BIOS and examine the settings.

BIOS Menu	Item	Value
Advanced, CPU Configuration	C1E Support	Enabled
	Hardware Prefetcher	Enabled
	Adjacent Cache line Prefetch	Disabled
	Intel® Virtualization Tech	Disabled
	Intel SpeedStep Tech	Enabled

BIOS Menu	Item	Value
Advanced, ACPI Configuration	Chipset ACPI configuration, High Precision Event Timer	Enabled
Advanced, PCI Bus Configuration	PCI Bus Compatibility Mode	GEN 2
	Video Card Support	Enabled
	Snoop Filter	Enabled
Boot, Boot Device Priority	1st	DVD
	2nd	SATA
	3rd	Embedded NIC 1

### HP DL140 BIOS Settings

The current certified system BIOS version for the HP DL140 system is **1.09**. The table below lists the correct BIOS settings for this system. Items not listed are set to their factory default.

To check the BIOS settings of the node, reboot the node, and when the boot process starts, press **F10** to enter the system BIOS and examine the settings.

BIOS Menu	Item	Value
Advanced	8042 Emulation Support	Disabled

### IBM eServer x336 BIOS Settings

There are two models of the x336, the olde 883741U and the newer 88371RU model. The current certified system BIOS version for both models is **1.13**.

The table below lists the correct BIOS settings for both models of the x336 Incinerator Nodes. Items not listed are set to their factory default.

You check the BIOS settings of the node as follows: log in directly to the node, initiate a reboot, and when the boot process starts, press **F1** to enter the system BIOS and examine the settings.

BIOS Menu	Item	Value
Devices and IO Ports	PCI Slot 2	Disabled
Advanced Setup Options, CPU Options	Hyper Threading Technology	Disabled
Startup Options	Boot Fail Count	Disabled

## QLogic BIOS Settings

IBM x346 Lustre Media Server machines use the QLogic QLA 2344 fibre channel adapters to connect to storage.

The table below lists the correct BIOS settings for each port on each of the QLogic adapters. Items not listed are set to their factory default. The QLogic boards that Autodesk ships with the Incinerator system have these BIOS settings already configured. You should not need to change these settings.

To display the BIOS menu for the QLogic adapters, reboot the system and, when the QLogic board starts initializing during the reboot, press **Ctrl+Q** to enter the QLogic BIOS settings.

---

**NOTE** The QLogic board takes only a few seconds to initialize so you should follow the boot messages closely and be ready to press **Ctrl+Q** as soon as you see the QLogic QLA board referenced in the boot messages.

---

BIOS Menu	Item	Value
Configuration Settings, Adapter Settings	BIOS Revision	1.43 <hr/> <b>NOTE</b> If the BIOS Revision is not 1.43, you must update the QLogic QLA board BIOS. Contact Autodesk Media and Entertainment Customer Support. Refer to Contacting Customer Support. They will guide you through the update process. <hr/>
	Data Rate	1, for ports attached to Stone Direct storage. Ports connected to an archiving device should be set to 0. This configures the port to Auto Select throughput.
	Fibre Channel Tape Support	Disabled for ports attached to Stone Direct storage or a SAN. Enabled for ports attached to a fiber channel tape device.
Configuration Settings, Advanced Adapter Settings	Execution Throttle	255 When connected to a SAN, set to 5
	LUNs per Target	64

# Installing Linux and the DKU

# 5

## Topics in this chapter:

- [Do I Need to Reinstall Linux?](#) on page 27
- [Choosing an Install Process](#) on page 28
- [Linux Installation Workflow](#) on page 29
- [Linux Post-Installation Tasks](#) on page 31
- [Installing the DKU](#) on page 31
- [Customizing Network Settings](#) on page 32

## Do I Need to Reinstall Linux?

Sometimes, when upgrading to a new version or service pack of your software, you might need to also upgrade the operating system.

Use the following table to determine the correct version of Red Hat Enterprise Linux required for your Lustre Workstation, Lustre Media Server, and Incinerator nodes hardware platforms for the current version.

Hardware Platform	Linux Version
HP Z800 HP ProLiant DL160 G6	Red Hat Enterprise Linux Desktop 5.3 With Workstation Option
HP xw8400, HP xw9400, HP xw8600 HP ProLiant DL160 G5 HP ProLiant DL140 G3	Red Hat Enterprise Linux WS 4, Update 3

To determine the version of Red Hat Enterprise Linux your system is currently running, open a terminal and type:

```
cat /etc/redhat-release
```

The Red Hat Enterprise Linux version appears. For example:

```
Red Hat Enterprise Linux WS release 4 (Nahant Update 3)
```

If your system is not currently running the correct version of Red Hat Enterprise Linux, upgrade your operating system to the required version.

## Choosing an Install Process

Before installing the Autodesk-customized version of 64-bit Red Hat Enterprise Linux in an Incinerator configuration, you need to choose an install process. There are two types of install processes:

- Centralized. For more information, see [Centralized Install Process](#) on page 28.
- Local. For more information, see [Local Install Process](#) on page 28.

## Centralized Install Process

In a centralized install process, you use the Lustre Media Server as a central repository for the Linux distribution, Discreet Kernel Utility (DKU), and network configuration information. All other components in the Incinerator configuration retrieve the Linux distribution, the DKU, and their network settings from the Lustre Media Server. This is the most efficient way to install Linux on all Incinerator components, and therefore the recommended install process when setting up a complete Incinerator configuration.

In this install process, you first install Linux and the DKU on the Lustre Media Server. During this Linux installation, the contents of the Autodesk-customized 64-bit Red Hat Enterprise Linux DVD are copied onto the Lustre Media Server. During the DKU installation, the contents of the DKU are copied onto the Lustre Media Server, and a file containing default network information for all components in the Incinerator configuration is created on the Lustre Media Server.

After you complete the Linux and DKU installation on the Lustre Media Server, install Linux and the DKU on each of the components in the Incinerator system. Each component retrieves and installs the Linux distribution, the DKU, and its network settings from the Lustre Media Server.

---

**NOTE** In this process you must insert the Autodesk-customized 64-bit Red Hat Enterprise Linux DVD in the CD-ROM drive to start the Linux installation on each component. However, only the Lustre Media Server performs the full installation from the DVD. All other components use the DVD only to boot; after the boot, they perform the installation over the network from the distribution located on the Lustre Media Server.

---

## Local Install Process

Use process to manually install Linux and the DKU, along with network configuration information, on a single Incinerator component.

This is the recommended install process when you are integrating components into an Incinerator configuration in which the correct version of Linux is already installed, or should you ever need to reinstall Linux on a single Incinerator component.

# Linux Installation Workflow

Perform the following procedure to prepare your system and install the customized Autodesk distribution of Red Hat Enterprise Linux.

## To install the Autodesk distribution of Linux:

- 1 Locate the installation media.

The DVD containing the customized Autodesk distribution of Red Hat Enterprise Linux is included with your shipment. The customized Autodesk distribution installs certain Linux packages that are required by Autodesk applications but are not installed by the commercial distribution of Red Hat Enterprise Linux.

---

**WARNING** Even though your shipment may also include the disc set for the commercial distribution of Red Hat Enterprise Linux, **DO NOT** install the commercial distribution. Autodesk Visual Effects, Finishing and Colour Grading software only works on the custom Autodesk distribution of Red Hat Enterprise Linux.

---

- 2 Power off all storage enclosures connected to the Lustre Media Server system, to prevent the Red Hat installer from attempting to reformat them as part of the installation process.

---

**WARNING** Do not skip this step. Failure to power off or disconnect your storage before installing Linux may result in data loss.

---

---

**NOTE** Turn off the XR RAID controllers first, then the XE expansion enclosures.

---

- 3 Make sure your system is in the following state:

- Mouse, keyboard and graphics monitor are connected and the graphics monitor is powered on.
- If you are using a KVM switch, it is switched to the system on which you want to install Linux.
- The storage array is powered off.
- The only network to which the system is connected is the Incinerator network. Each Incinerator component connects to the Incinerator network through port 0 of their on-board house network card.

- 4 Insert the DVD of the Autodesk distribution of Red Hat Enterprise Linux in the DVD-ROM drive, and power off the system.

---

**WARNING** If your system is equipped with internal media storage, after turning the system off, open the side panel and disconnect the main connector for the internal storage drives. Make sure you do not disconnect the system drive!

---

- 5 Power on your system.

- 6 When the system reboots, press **F9** to enter the boot menu, and select Optical Drive to boot from the Red Hat Enterprise Linux installation DVD.

- 7 When the Red Hat Linux installation screen appears, press **F8** to display the Autodesk Red Hat Linux installation menu.

- 8 At the boot prompt in the Red Hat Linux installation menu, type one of the following commands and then press **Enter** to launch the Linux installation.

---

**Type:**

**To install on:**

**inclms**

A Lustre Media Server.

---

Type:	To install on:
<code>incws incws=&lt;x&gt;</code>	An Incinerator workstation in a centralized install process, where <x> is an integer you assign to the workstation to distinguish it from other workstations in the configuration. For example, the following assigns the number "2" to this workstation: <code>incws incws=2</code>
<code>incws_cd incws=&lt;x&gt;</code>	An Incinerator workstation in a local install process, where <x> is an integer you assign to the workstation to distinguish it from other workstations in the configuration. For example, the following assigns the number "2" to this workstation: <code>incws_cd incws=2</code>
<code>incnode incnode=&lt;x&gt;</code>	An Incinerator node in a centralized install process, where <x> is an integer you assign to the node to distinguish it from other nodes in the configuration. For example, the following assigns the number "9" to this node: <code>incnode incnode=9</code>
<code>incnode_cd incnode=&lt;x&gt;</code>	An Incinerator node in a local install process, where <x> is an integer you assign to the node to distinguish it from other nodes in the configuration. For example, the following assigns the number "9" to this node: <code>incnode_cd incnode=9</code>

**NOTE** The system spends several minutes loading drivers.

- 9 If you replaced your system disk with an uninitialised disk, when prompted, confirm initialisation of the disk.
- 10 If you are installing Linux using a centralized install process and receive an error that "The directory could not be mounted from the server", the default IP address for the Lustre Media Server is not working. Click OK and when prompted, enter the following information, then press **Enter**.

In the field:	Type:
NFS server name	The IP address of the Lustre Media Server. For example, if you are using the default IP address for the Lustre Media Server, enter <code>10.10.10.1</code>
Red Hat Enterprise Linux directory	<code>/root/iso/rh4u3_64</code> or <code>/root/iso/rh5u3_64</code>

**NOTE** If this error occurs when the IP address *is* correct, the problem may be due to hardware connections. Verify all hardware connections between the component and the Lustre Media Server are properly seated, then reboot the machine and restart the Linux installation.

- 11 The remainder of the installation process is automated. When the installation completes, you are prompted with "Congratulations, the installation is complete".

**NOTE** If the installation drops into text mode or to a blank screen just before completing, press **CTRL+ALT+F6** to return to graphical mode. At this point, the installation should be finished, and you should see the "Congratulations..." message and the Reboot button.

- 12 Eject the DVD and click Reboot to reboot the system.

**NOTE** After the system reboots, you may be prompted by the Kudzu hardware setup utility to set up new hardware detected for your system. You can ignore these prompts and allow the utility's count-down to expire since the hardware for the system is unchanged.

# Linux Post-Installation Tasks

After booting into your new Linux installation, perform the following post-installation tasks:

- Change the default root password to secure the system. The customized Autodesk installation sets the password for the root account on your workstation to *password*.
- Configure the time zone for your geographic location. The workstation is set to North American Eastern Standard Time (EST) by default. If necessary, consult the Red Hat online documentation to configure this setting.
- Configure the network settings for your workstation to match the ones used in your facility. The Linux installation sets a default IP address for your workstation. If you are using a centralized install process, you only need to configure network settings if you do not want to use the default network hostnames and addresses set during Linux installation. Refer to [Customizing Network Settings](#) on page 32 for information on using the *incnetcfg* utility to customize network settings. If you performed a local Linux install, make sure to install the DKU before using *incnetcfg*. See [Installing the DKU](#) on page 31.
- Enable multicasting if you are planning to access the system from a remote workstation. To enable multicasting, open the */etc/sysconfig/network* file in a text editor, add a GATEWAY keyword, and specify the gateway IP address. Obtain the necessary information from your network administrator.

---

**NOTE** If you do not define a gateway in */etc/sysconfig/network*, you must define default routes associated with specific interfaces in */etc/sysconfig/network-scripts/ifcfg-*<xxx>**, where *<xxx>* specifies your ethernet adapter. Note that a default route specified in the *network* file overrides any *ifcfg-*<xxx>** routes. Contact your system administrator to determine the best way to enable multicasting for your network.

---

## Installing the DKU

Before installing your software, you must install the required version of the DKU on all components. See the Release Notes for the required DKU version for this version.

---

**NOTE** If you used a centralized install process to install Linux in an Incinerator configuration, the DKU was installed automatically after the Red Hat Linux installation completed.

---

For major releases, the DKU is available on optical media or as a download from Autodesk. For extensions and service packs, the DKU is only available for download. The download links are provided in the release announcement you received from Autodesk.

### To install the DKU:

- 1 Open a terminal and log in as root.
- 2 If you are upgrading an existing application, check the currently installed DKU version by typing:  
**head -n1 /etc/DKUversion**  
If the DKU version output by the command does not match the version required for the new application version, perform the remaining steps in this procedure.
- 3 Access your DKU installation package:
  - If you are installing from an application disc, insert and mount the disc using the command:  
**mount /dev/cdrom**  
The disc mounts on the */mnt/cdrom* directory. The DKU installation directory is located at the top level directory of the disc.

- Otherwise, download the latest DKU *tar* file from the download link provided in the release announcement, then go to the directory where the *tar* file was downloaded, and unpack it by typing:  
**tar -zxvf DKU\_<version\_number>.tar.gz**  
The DKU *tar* file is unpacked into a new directory.

- 4 Go to the DKU installation directory and launch the DKU installation script:  
**./INSTALL\_DKU**

---

**WARNING** If you attempt to install the DKU on an unsupported platform, the installation script only installs a generic configuration. Such a configuration can render your operating system unusable. Never attempt to install the current version of the DKU on unsupported platforms, including older Visual Effects and Finishing or Colour Grading systems that are no longer supported in the current version.

---

- 5 If you installed from a disc, return to the root directory, and eject the disc by typing:  
**eject**

- 6 Before rebooting the system, do the following:
  - If storage devices (external disk arrays or internal storage) were previously disconnected or turned off as part of an operating system installation, reconnect them and power them up.

---

**NOTE** Power on the XE expansion enclosures first and the XR RAID controller units last. This ensures the RAID controllers detect the other units in the Stone Direct storage.

---

Wait for all the disks in the storage devices to power up before rebooting the system. The green light for each disk stops flashing once it is fully powered up

- 7 Reboot the system. Type:  
**reboot**

## Customizing Network Settings

The DKU automatically configures default hostnames, IP addresses, and subnet masks for all components in the Incinerator system. If necessary, you can modify these default settings for all or any one of the Incinerator components through the *incnetcfg* command.

---

**NOTE** In most cases the default hostnames, IP addresses, and subnet masks do not require any change. It is therefore recommended that, unless you have a specific reason for changing these, you leave the default settings in place.

---

## Customizing Network Settings in a Centralized Install Process

In a centralized installation install process, you customize network settings for all Incinerator components on the Lustre Media Server. You do this *after* you install Linux and the DKU on the Lustre Media Server and *before* you install Linux on the other components in the Incinerator configuration. When you subsequently install Linux on a component, the Linux installation retrieves the network settings for that component from the Lustre Media Server.

Use the first procedure in this section to configure the network settings for each component in the Incinerator configuration. Use the second procedure to reset network settings for all components in the Incinerator configuration to default values.

### To configure network settings for a centralized installation:

- 1 After you complete installation of Linux and the DKU on the Lustre Media Server (and before you install Linux on the other components in the Incinerator configuration), log in to the Lustre Media Server as root and open a Terminal.
- 2 In the Terminal, type:  
**incnetcfg -cluster**  
The *incnetcfg* utility launches, displays the current network settings for the first Incinerator component, and prompts you to confirm whether those settings are accurate.
- 3 Type one of the following.

Type:	If the network information is:
<b>n</b>	Inaccurate. In this case the utility prompts you for the correct network information for the first Incinerator component. At each prompt, enter the appropriate piece of network information and press <b>Enter</b> . After you have entered all network information for the component, the utility displays a summary of what you entered and prompts for confirmation that the information is accurate.
<b>y</b> or <b>Enter</b>	Accurate. In this case the utility displays the network information for the next Incinerator component.

- 4 Repeat the preceding step until the utility has network information for all Incinerator components in the configuration and exits.
- 5 Reboot the Lustre Media Server.  
When you install Linux on the other Incinerator components, the Linux installation retrieves the network settings for the component from the Lustre Media Server.

### To reset network settings for a centralized install process:

- 1 After you complete installation of Linux on the Lustre Media Server (and before you install Linux on the other Incinerator components), log in to the Lustre Media Server as root and open a Terminal.
- 2 In the Terminal, type the following to delete the file containing the network configuration information:  
**rm /usr/discreet/DKU/INC/cluster.cfg**
- 3 In the Terminal, type:  
**incnetcfg -cluster auto**  
The *incnetcfg* utility launches, resets the network information for all Incinerator components to default values, displays those default values, and exits.
- 4 Reboot the component.

## Customizing Network Settings for a Single Component

Use the first procedure in this section to configure the network settings of a single Incinerator component. Use the second procedure to reset network settings for the component to default values. These procedures assume Linux and the DKU are installed on the component.

### To verify or configure network settings for a single component:

- 1 Log in to the component as root and open a terminal.

- 2 Type one of the following commands.

To configure settings for:	Type:
A Lustre Media Server	<b>incnetcfg -lms</b>
A workstation	<b>incnetcfg -wrks</b> <workstation#>
	<b>NOTE</b> Instead of the workstation number, you can use <b>auto</b> . This parameter sets the workstation number to 1.
An Incinerator node, where <node#> is the node number you assigned to the node when you installed Linux.	<b>incnetcfg -incnode</b> <node#>

For example, to configure settings on Incinerator node 2, type:

```
incnetcfg -incnode 2
```

The *incnetcfg* utility launches, displays the current network settings for the component you specified, and prompts you to confirm whether those settings are accurate.

- 3 Type one of the following.

Type:	If the network information is:
<b>n</b>	Inaccurate. In this case the utility prompts you for the correct network information. At each prompt, enter the appropriate piece of network information and press <b>Enter</b> . After you have entered all network information for the component, the utility displays a summary of what you entered and prompts for confirmation that the information is accurate. Type <b>y</b> to indicate the network information is accurate.
<b>y</b>	Accurate.

- 4 The utility displays the network information, saves any modifications to it, and exits.
- 5 Reboot the component.

#### To reset network settings for a single component to default values:

- 1 Log in to the component as root and open a terminal.
- 2 Type the following to delete the file containing the network configuration information:  
**rm /usr/discreet/DKU/INC/cluster.cfg**
- 3 Type:  
**incnetcfg -cluster auto**  
The *incnetcfg* utility launches, resets the network information to default values, displays those default values, and exits.
- 4 Reboot the component.

# Configuring Storage

# 6

## Topics in this chapter:

- [Overview](#) on page 35
- [Connecting to the RAID Controller for the First Time](#) on page 36
- [Creating Hardware LUNs](#) on page 37
- [Partitioning Disks or LUN devices as LVM-type Primary Partitions](#) on page 39
- [Assembling the Disk or LUN Devices into a Logical Volume](#) on page 40
- [Creating the XFS Filesystem on the LVM device](#) on page 42
- [Creating a Mount Point and Mounting the Storage](#) on page 43

## Overview

This chapter describes how to connect a direct-attached storage to the Lustre Media Server and configure it to provide access to all frames and proxies.

In the Incinerator system, the Lustre Media Server is the gateway to the storage devices, providing the workstation and Incinerator Nodes access to the frames it stores. Properly configured storage is essential to ensuring real-time playback of 2K 10-bit frame sequences with grades and effects.

If you are also configuring a Storage Area Network (SAN), it is recommended that you configure the SAN prior to configuring a direct-attached storage.

---

**NOTE** Before you can configure the storage, the Lustre Media Server must be up and running the custom Autodesk distribution of Red Hat Enterprise Linux, as well as the version of the DKU required for your application version.

---

## Do I Need to Perform these Procedures?

If you are reinstalling your system from scratch, or adding new storage devices, refer to the procedures in this section for information on partitioning the storage and setting up the XFS filesystem.

If you are only upgrading an existing application installation without adding new storage, skip to the next chapter for instructions on installing the software.

## Connecting to the RAID Controller for the First Time

### Powering Up Your Storage

Powering your system and storage up or down should be done in a proper sequence. This will ensure that the system functions properly.

---

**WARNING** An incorrect power up sequence can mean your system does not recognize all drives.

---

**To power up your system:**

- 1 Make sure your Lustre Media Server is shut down.
- 2 Power up the storage expansion enclosures.
- 3 Power up the storage RAID controller units.
- 4 Wait about 90 seconds for all the drives to spin up. Their lights are solid green when they are spun up.
- 5 Power up your Lustre Media Server.

To power down your system, shut down your Lustre Media Server first, then the RAID controller units, and finally the expansion enclosures.

### Connecting to the RAID Controllers

Each of the two RAID controllers in an XR RAID enclosure has its own IP address; you can configure LUNs by connecting to either of the two. The factory default IP address of RAID controller 0 (the bottom controller) is 10.1.1.5. For RAID controller 1 (the top controller) the factory default IP address is 10.1.1.6.

**To connect to the controller and set its IP address:**

- 1 Connect the second Ethernet port on your Lustre Media Server to the Ethernet port of RAID controller 0.
- 2 Set the second Ethernet interface on your Lustre Media Server to 10.1.1.100. As root, open a terminal and type:  

```
ifconfig eth1 10.1.1.100 netmask 255.255.255.0
```
- 3 Launch the Stone Storage Manager RAID management utility by pointing a Web browser from your Lustre Media Server at the IP address of the RAID controller. For example, <http://10.1.1.5:9292>
- 4 When prompted to enter a user name and password, enter the user name *admin* and the password *password*.
- 5 Optional: perform the following steps to change the RAID controller IP address to one that is consistent with your local network.
  - In the Stone Storage Manager, click Settings.

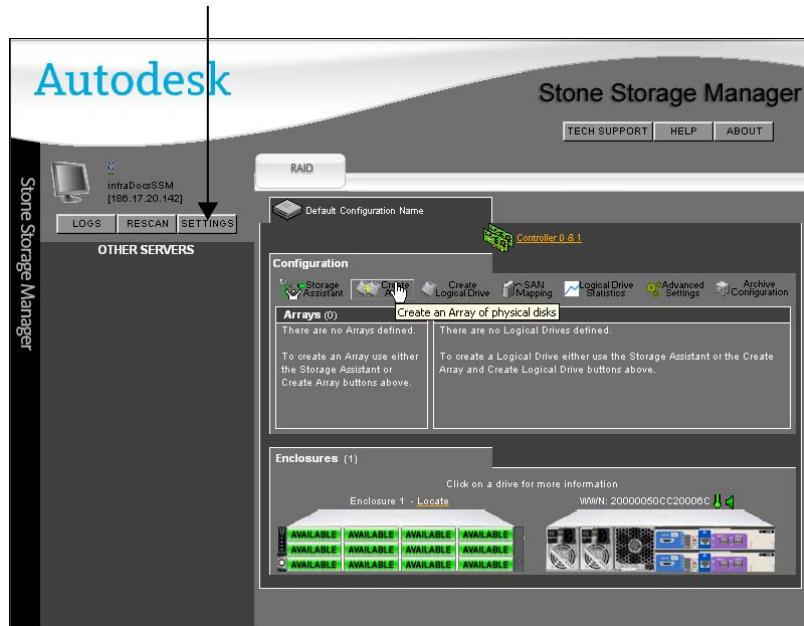

- Select the Preferences tab.

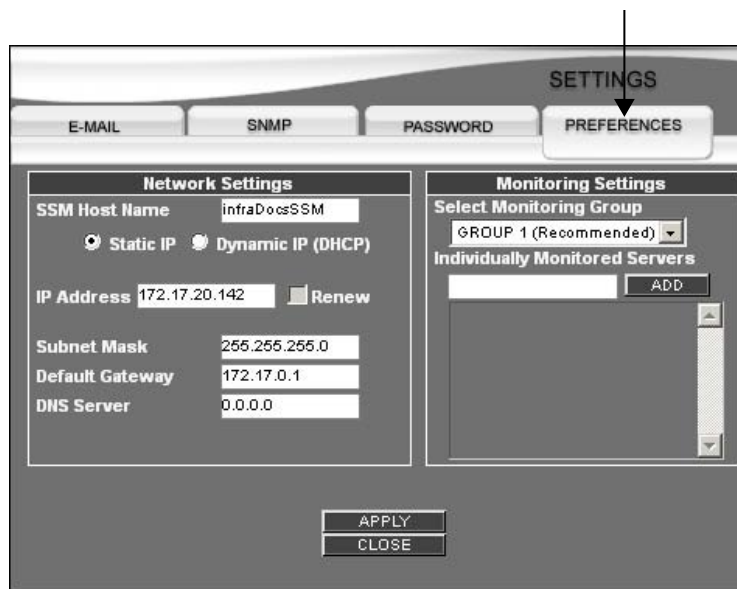

- Enter hostname and IP information and click APPLY.

## Creating Hardware LUNs

LUNs, also referred to as Logical Units or Logical Drives, are groups of disk drives that are striped together to provide optimal performance and RAID protection. Once configured, LUNs are seen by the Linux operating system as if they were single disk drives.

To create the LUNs on your XR-series storage, use the *XR Configurator* utility supplied by Autodesk. This utility is installed with the DKU and automates the LUN creation process.

---

**NOTE** For systems having 2XR or 2XR + 2XE, you have to configure one XR at a time with the XR Configuration Utility. Connect the first XR and use the utility to configure. When done, disconnect the first XR and connect the second XR. When the second XR is configured re-connect the two XRs.

---

**To configure LUNs on XR-series storage:**

- 1 Open a terminal and log in as root.
- 2 Go to the directory `/usr/discreet/DKU/current/Utils/Storage/current/`, and run the XR configuration utility by typing:  

```
./XR_config.pl
```

The script detects whether a LUN configuration exists on the storage attached to that Lustre Media Server.
- 3 If a LUN configuration already exists on the storage, you are prompted for confirmation to overwrite that configuration.

---

**WARNING** LUN configuration is destructive. Make sure you want to overwrite an existing configuration before you confirm.

---

- 4 After the script detects the number of enclosures and drives, it prompts you to indicate the filesystem your storage uses.  
Type **2**
- 5 When asked if you have a 2-loop or a 4-loop configuration, select the option that applies to your storage. The XR configuration utility configures your storage.

---

**NOTE** You can monitor the LUN creation process by accessing the Stone Storage Manager utility on the RAID controllers through a Web browser. However, it is not necessary to launch SSM for LUN configuration.

---

- 6 Type **x** to exit the configuration utility.

The XR configuration utility exits without configuring your storage if any of the following issues are detected:

- An incorrect number of disks. The total number of disks must be a multiple of 12.
- One or more of the enclosures do not have the correct firmware.
- In a dual RAID enclosure environment, the number of expansion chassis on each RAID enclosure is not the same.

## Rescanning New LUNs from the Host Operating System

Newly-created LUNs must be rescanned by the host operating system to associate the proper disk devices with each LUN.

**To rescan LUNs:**

- 1 Reboot the system.
- 2 To verify the new LUNs were detected, examine the content of the file `/proc/scsi/scsi`.
- 3 You can also see the current configuration by going to the `/usr/discreet/DKU/current/Utils/Storage/current/` directory, and typing:  

```
XR_config.pl -status
```

# Partitioning Disks or LUN devices as LVM-type Primary Partitions

To achieve optimal performance, each disk or LUN in the DAS array should be partitioned as a single primary partition of type “Linux LVM”.

---

**NOTE** If your storage arrays use 450GB drives, skip this section and continue with [Assembling the Disk or LUN Devices into a Logical Volume](#) on page 40.

---

**To re-partition disk or LUN devices as LVM-type primary partitions:**

- 1 Open a terminal and log in as root.
- 2 Reload the drivers for the fibre channel card.
  - For HP Z800 systems using the ATTO Celerity FC-84EN card type:  

```
rmmod celerity8fc  
modprobe celerity8fc
```
  - For older HP systems using the ATTO Celerity FC-44ES card type:  

```
rmmod celerityfc  
modprobe celerityfc
```
- 3 View a list of disks or LUNs devices detected by the operating system, using the following command:  

```
fdisk -l | grep dev
```

Identify the disk or LUN devices that are part of the DAS that will be configured with a standard filesystem. These devices will be re-partitioned.

---

**NOTE** Make sure you do not re-partition the system drive or any other disks that you want to preserve as they are. Partitioning destroys all data on the disks.

---

- 4 Use the *fdisk* command to re-partition each disk device identified in the previous step.  
Start the *fdisk* utility for the LUN. Type:  

```
fdisk <disk name>
```

where *<disk name>* is a disk device name without a partition number, such as */dev/sdf*.  
The *fdisk* utility starts, checks the disk device, and then displays its prompt.
- 5 Type **n** to display the New partition creation menu.  
*fdisk* displays the type of partitions you can create (primary or extended).
- 6 Create a primary partition on the disk device by typing **p** at the prompt.
- 7 When prompted to enter a partition number, type **1** to make the primary partition the first one on the LUN.

---

**NOTE** You may have to delete pre-existing partition by entering **d** when prompted, and repeating step 3.

---

- 8 When prompted to set the starting cylinder number, press **Enter** twice to accept the default, that is, the first and last cylinder on the device.  
The *fdisk* prompt reappears.

- 9 Type **t** to set the partition type.  
You are prompted to enter the hexadecimal code of the partition type to be created on the LUN.
- 10 Type **8e** to set the partition type to Linux LVM.  
*fdisk* sets the partition as Linux LVM and the following output appears:  
Changed system type of partition 1 to 8e (Linux LVM)
- 11 Type **w** to save the new partition table.
- 12 Repeat steps 2 through 9 for each disk or LUN device identified in step 1.

## Assembling the Disk or LUN Devices into a Logical Volume

After you have formatted each disk or LUN device as a Linux LVM partition, you must assemble the LUNs into a single LVM logical volume on which you create the XFS filesystem.

This procedure does not cover creating fault-tolerance and assumes that the LUNs are RAID-protected, as is the case with Stone Direct XR-series arrays.

---

**NOTE** It is not recommended to create an LVM volume using the *md* RAID driver, as it has been found to provide poor performance with XFS.

---

### To assemble an LVM logical volume:

- 1 Verify that the disk or LUN devices are detected by the operating system. Type:

```
fdisk -l | grep dev
```

All devices appear in a list similar to the following example (your values may vary):

- For arrays with 450GB drives:  
Disk /dev/sdb: 2227.7 GB, 2227760529408 bytes  
Disk /dev/sdc: 2227.7 GB, 2227760529408 bytes  
Disk /dev/sdd: 2227.7 GB, 2227760529408 bytes  
Disk /dev/sde: 2227.7 GB, 2227760529408 bytes
- For arrays with smaller capacity drives:  
Disk /dev/sdf: 726.2 GB, 726247931904 bytes  
/dev/sdg1 1 88294 709221523+8eLinux LVM  
Disk /dev/sdg: 726.2 GB, 726247931904 bytes  
/dev/sdh1 1 88294 709221523+8eLinux LVM

---

**NOTE** Other devices of different types may be listed before and after the LVM devices.

---

- 2 Create a physical volume on each of the devices using the following command:

```
pvcreate <list of devices>
```

where *<list of devices>* is a list of all LVM devices. For example, if you have four devices, ranging from */dev/sdb* to */dev/sde*, you would type:

- For arrays with 450GB drives:  
**pvcreate /dev/sdb /dev/sdc /dev/sdd /dev/sde**
- For smaller capacity drives:  
**pvcreate /dev/sdb1 /dev/sdc1 /dev/sdd1 /dev/sde1**

The physical volumes are created, and the command output should be similar to the following example:

```
Physical volume "/dev/sdb" successfully created
Physical volume "/dev/sdc" successfully created
Physical volume "/dev/sdd" successfully created
Physical volume "/dev/sde" successfully created
```

---

**TIP** You can use the command *pvremove* to delete any erroneously entered devices.

---

- 3 Verify that the physical volumes were initialized correctly. Type:

```
pvscan -v
```

A list of all of the physical volumes you created appears. Each volume should contain “lvm2”. The following sample output is for the previous example of 4 LVM physical volumes created on devices */dev/sdb* through */dev/sde*:

```
Wiping cache of LVM-capable devices
Wiping internal VG cache
Walking through all physical volumes
PV /dev/sdb lvm2 [2.03 TB / 2.03 TB free]
PV /dev/sdc lvm2 [2.03 TB / 2.03 TB free]
PV /dev/sdd lvm2 [2.03 TB / 2.03 TB free]
PV /dev/sde lvm2 [2.03 TB / 2.03 TB free]
Total: 4 [8.10 TB] / in use: 0 [0 ] / in no VG: 4 [8.10 TB]
```

- 4 Create the volume group “vg00” from the physical volumes you created in the preceding step, using the following command:

```
vgcreate vg00 <list of volumes>
```

where <list of volumes> is the list of physical volumes you created in the preceding step. For example:

- For arrays with 450GB drives:

```
vgcreate vg00 /dev/sdb /dev/sdc /dev/sdd /dev/sde
```

- For smaller capacity drives:

```
vgcreate vg00 /dev/sdb1 /dev/sdc1 /dev/sdd1 /dev/sde1
```

---

**TIP** You can use the command *vgremove* to delete any erroneously entered volume.

---

- 5 Verify the volume was created and obtain the value of the “Free PE / Size” field. Type:

```
vgdisplay -v
```

In the output, find the line that contains the “Free PE / Size” field and write down the value of the “Free PE”. For example, in the following example output the “Free PE” value is 2124556.

```
Free PE / Size 2124556 / 8.10 TB
```

- 6 Create a new logical volume on “vg00”, using the following command:

```
lvcreate -l <Free_PE_value> -i <#_of_physical_volumes> -I 32 -n lvol1  
vg00
```

where <Free\_PE\_value> is the “Free PE” value you noted in the preceding step and <#\_of\_physical\_volumes> is the number of physical volumes. If we continue with the example used in the previous steps, you would type:

```
lvcreate -l 2124556 -i 4 -I 32 -n lvol1 vg00
```

The output confirms the creation of the logical volume:

Logical volume "lv011" created

---

**NOTE** If the command outputs several lines about a file descriptor leaked on `lvdisplay` invocation, ignore them.

---

- 7 Check if the `adsk_lvm` startup script has been installed by the DKU to enable automatic LVM reassembly upon reboot:

```
chkconfig --list | grep adsk_lvm
```

if the script is properly configured, the command output is the following:

```
adsk_lvm 0:off 1:off 2:on 3:on 4:on 5:on 6:off
```

If the command output is different, enable the script by typing:

```
chkconfig --add adsk_lvm
```

```
chkconfig adsk_lvm on
```

## Creating the XFS Filesystem on the LVM device

After having created the LVM logical volume, you are now ready to create and mount the XFS filesystem.

**To create and mount an XFS filesystem:**

- 1 Identify the optimal `agsize` value for your array by running the `mkfs.xfs` command. Type:

```
mkfs.xfs -d agcount=128 -f /dev/vg00/lv011
```

This command displays diagnostics information similar to the following (your values may differ):

```
meta-data=/dev/vg00/lv011 agcount=128, agsize=1066667 blks
          =                sectsz=512 attr=0
data      =                bsize=4096 blocks=134400000, imaxpct=25
          =                sunit=16   swidth=64 blks, unwritten=1...
```

- 2 From the diagnostic information printed in the previous step, note the following values:
  - `agsize` on the first line
  - `sunit` and `swidth` on the fourth line
- 3 Depending on the values of `sunit` and `swidth`, calculate a new `agsize` value using one of the following three methods:
  - If the values of `sunit` and `swidth` are both equal to 0, multiply the `agsize` value by 4096. For example (your values will differ):  
 $1066667 * 4096 = 4369068032$   
Proceed to step 4 using the value calculated above as the new `agsize` value.
  - If the command displays a warning message about the `agsize` being a multiple of the stripe width, multiply the `agsize` value by 4096, and subtract the `sunit` value multiplied by 4096. For example (your values will differ):  
 $1066667 * 4096 = 4369068032$   
 $16 * 4096 = 65536$   
 $4369068032 - 65536 = 4369002496$   
Proceed to step 4 using the value calculated above as the new `agsize` value.
  - If the values of `sunit` and `swidth` are not equal to 0, and no warning message appears, proceed to step 4 using the `agsize` value displayed by the `mkfs.xfs` command in step 1.

- 4 Run the `mkfs.xfs` command again to create the XFS filesystem on the device `/dev/vg00/lvol1` using the value calculated in one of the previous steps. Type:

```
mkfs.xfs -d agsize=<new agsize> -f /dev/vg00/lvol1
```

For example (your values will vary):

```
mkfs.xfs -d agsize=4369068032 -f /dev/vg00/lvol1
```

The filesystem is created on the storage array.

---

**NOTE** If the command fails, redo your calculations starting from step 1.

---

- 5 Verify that the storage can be mounted by typing:

```
mount /mnt/md0
```

The storage should mount, as the DKU installation script should have created the mount point directory `/mnt/md0` for your storage, as well as the corresponding entry in the `/etc/fstab` file.

If you receive an error message and the storage does not mount, follow the instructions in the next section to manually mount the storage.

## Creating a Mount Point and Mounting the Storage

If the mount point directory for your storage was not created automatically by the DKU, or if the storage does not mount, perform the following procedure to create the mount point and mount the storage manually.

**To create a mount point and mount the storage:**

- 1 Create the directory that will serve as the mount point for the filesystem, if it does not exist. For example:

```
mkdir /mnt/md0
```

- 2 Mount the XFS filesystem from the logical volume `/dev/vg00/lvol1` on the directory you created in the previous step. For example:

```
mount -av -t xfs -o rw,noatime,inode64 /dev/vg00/lvol1 /mnt/md0
```

The filesystem is mounted as `/mnt/md0`.

- 3 Confirm that the storage is now mounted. Type:

```
df -h
```

The output should list `/dev/mapper/vg00-lvol1` mounted on your mount point directory. For example:

```
/dev/mapper/vg00-lvol1
```

```
814G 547G 267G 68% /mnt/md0
```

- 4 Using a text editor, add an entry in the `/etc/fstab` file so that the filesystem gets mounted automatically at startup. For example:

```
/dev/vg00/lvol1 /mnt/md0 xfs rw,noatime,inode64
```

- 5 Optional: confirm that the filesystem can mount automatically by rebooting the Lustre Media Server and using the command `df -h` again.



# Installing Incinerator Software

# 7

## Topics in this chapter:

- [Workflow for Installing Incinerator Software](#) on page 45
- [Copying the Application Software onto the Lustre Media Server](#) on page 46
- [Installing the Lustre Media Server Software](#) on page 46
- [Installing the Incinerator Node Software](#) on page 47
- [Installing the Workstation Software](#) on page 47

## Workflow for Installing Incinerator Software

The recommended steps for installing Incinerator and Lustre software are as follows. In this workflow you copy the software for all components onto the Lustre Media Server, and then perform the software install on each component from the Lustre Media Server.

This workflow assumes all components are already running the correct distribution of Red Hat Linux, and the correct version of the *Discreet Kernel Utilities* (DKU). For help installing Linux and the DKU in an Incinerator configuration, see [Installing Linux and the DKU](#) on page 27.

Step:	Refer to:
1. Copy the application installation package onto the Lustre Media Server.	<a href="#">Copying the Application Software onto the Lustre Media Server</a> on page 46.
2. Install server software on the Lustre Media Server.	<a href="#">Installing the Lustre Media Server Software</a> on page 46.
3. Install inline rendering software on each Incinerator Node.	<a href="#">Installing the Incinerator Node Software</a> on page 47.

---

**Step:****Refer to:**

4. Install Lustre on the grading workstation.

[Installing the Workstation Software](#) on page 47.

---

## Copying the Application Software onto the Lustre Media Server

Copy the contents of the software installation package (from the optical disc or from a downloaded *tar* file) onto the Lustre Media Server so you can install the application software for each component in the workgroup from the Lustre Media Server.

### To copy the Server software onto the Lustre Media Server:

- 1 On the Lustre Media Server, log in as root.
- 2 Create a directory on the Lustre Media Server to hold the contents of the installation package by typing:  

```
mkdir -p /usr/discreet/DKU/INC/
```
- 3 If you are installing from an optical disc, insert the disc in the disc drive, mount it, and copy the contents of the CD into the new directory by typing:  

```
cp -r /mnt/cdrom/* /usr/discreet/DKU/INC/
```
- 4 If you are installing from a downloaded *tar* file, browse to the */usr/discreet/DKU/INC/* directory and unpack the *tar* file into it, by typing:  

```
tar zxvf <tar_file_name>
```

## Installing the Lustre Media Server Software

To install Server software on the Lustre Media Server, run the Lustre Media Server installation script. The installation script also installs the Incinerator license server and the *BrowseD* daemon, and configures them to start automatically at boot.

---

**NOTE** After you install the *BrowseD* license, you must restart the *BrowseD* daemon.

---

### To install the Server software on the Lustre Media Server:

- 1 On the Lustre Media Server, log in as root.
- 2 Navigate to the directory containing the installation script by typing:  

```
cd /usr/discreet/DKU/INC/lustre_<version_number>
```
- 3 Start the installation script for the Lustre Media Server. Type:  

```
./INSTALL_LUSTRE_<version_number>_SERVER
```

The software package is installed on the Lustre Media Server. The installation script installs and configures Incinerator daemons and utilities.
- 4 Reboot the Lustre Media Server.  
The *BrowseD* daemon is started automatically at reboot.

# Installing the Incinerator Node Software

To install both inline and background rendering software on an Incinerator node, use *ssh* to log in remotely to the node from the Lustre Media Server and run the installation script. You must repeat this procedure for each node.

The installation script starts the *renderd* daemon when the installation process is complete.

---

**NOTE** To complete the following procedure, the Incinerator private GigE network must be fully installed and functioning.

---

## To install inline and background rendering software on the Incinerator Nodes:

- 1 Log in to the Lustre Media Server as root.
- 2 Open a secure shell to log in to the node. Type:  
**ssh <NODE\_IP>**  
where <NODE\_IP> is the GigE IP address of the node you want to log in to. For example, to log in to the first node, type:  
**ssh 10.10.10.101**
- 3 Navigate to the directory containing the installation script by typing:  
**cd /hosts/<lms\_hostname>/usr/discreet/DKU/INC/lustre\_<version\_number>**  
Where <lms\_hostname> is the hostname of the Lustre Media Server. In a default configuration this name would be *server*.
- 4 Start the installation. Type:  
**./INSTALL\_LUSTRE\_<version\_number>\_RENDERNODE**  
The Incinerator Node package is installed.
- 5 Reboot the Incinerator node.
- 6 Repeat these instructions to install the inline rendering software on each Incinerator Node.

# Installing the Workstation Software

To install Lustre on the workstation, use *ssh* to log in remotely to the workstation from the Lustre Media Server and launch the workstation installation script.

---

**NOTE** To complete the following procedure, the Incinerator private GigE network must be fully installed and functioning.

---

## To install the workstation software:

- 1 Log in to the Lustre Media Server as root.
- 2 Open a secure shell to log in to the workstation. Type:  
**ssh <WS\_IP>**  
where <WS\_IP> is the GigE IP address of the workstation. For example, type:  
**ssh 10.10.10.201**
- 3 Navigate to the directory containing the installation script by typing:  
**cd /hosts/<lms\_hostname>/usr/discreet/DKU/INC/lustre\_<version\_number>**

Where `<lms_hostname>` is the hostname of the Lustre Media Server. In a default configuration this name is *server*.

- 4 Start the installation. Type:

```
./INSTALL_LUSTRE_<version_number>_INCINERATOR
```

---

**NOTE** During installation, if you are prompted to confirm whether you want to start Backburner Manager automatically, answer No.

---

The Incinerator package is installed on the workstation.

- 5 Reboot the workstation.

---

**NOTE** After the workstation reboots, open a Web browser, access the Incinerator Resource Manager, and group your Incinerator nodes into groups (clusters). See the next chapter for information.

---

# Using the Incinerator Resource Manager

# 8

## Topics in this chapter:

- [Overview](#) on page 49
- [Starting the Resource Manager](#) on page 50
- [Understanding the User Interface](#) on page 52
- [Managing Node Groups](#) on page 52
- [Monitoring Incinerator Nodes](#) on page 59
- [Monitoring Lustre Media Servers](#) on page 61
- [Monitoring Lustre Workstations](#) on page 62
- [Monitoring Command-Line Rendering](#) on page 64
- [Stopping and Starting Incinerator Daemons](#) on page 64
- [Deleting Duplicate Entries](#) on page 66
- [Managing Resource Manager User Accounts](#) on page 67

## Overview

The primary purpose of the Incinerator Resource Manager is to permit remote monitoring and management of Incinerator nodes (responsible for inline rendering in Lustre). It is also useful for monitoring the status of the Lustre Media Server and Lustre workstations themselves. You can gain access to the Resource Manager from any workstation equipped with a Web browser that has access to the Incinerator network.

---

**NOTE** By default, you can use the Resource Manager without logging in. However, when setting up the software, it is recommended you create password-protected user accounts. These are created from within the Resource Manager, and are distinct from any Linux user accounts that may already be in place. See [Managing Permissions](#) on page 69.

---

# Before You Begin

Please note the following general points:

- **Incinerator Resource Manager Name or IP Address.** In order to connect to the Incinerator Resource Manager, you require its name, host name, or IP address.
- **User Account and Password.** It is possible to make use of the Incinerator Resource Manager without logging in, but depending on how your system administrator has configured it, a user account and password may be required to perform some tasks.
- **Administrator Privileges.** Users without administrator privileges can perform the specific tasks associated with user accounts. Administrator privileges may be required for some tasks.
- **Node Groups/Clusters.** Before you can use Incinerator for inline rendering in Lustre, there must exist a node group to which Lustre users can connect. See [Managing Node Groups](#) on page 52.

# Starting the Resource Manager

When you start the Incinerator Resource Manager, you are automatically logged in as the user “anonymous”. Like all users, this user can view the status of all the components of the Incinerator system, including the Incinerator nodes, Lustre Media Server and Lustre workstations. However, depending on how your system administrator has configured the Resource Manager, your ability to perform tasks may be limited.

To start the Incinerator Resource Manager:

- 1 Open a Web browser on a workstation that has access to the Incinerator network.
- 2 In the browser's address field, enter `http://<lustre_media_server>/incinerator`, where `<lustre_media_server>` is the Gigabit Ethernet (GigE) IP address of the Lustre Media Server. For example, if the Lustre Media Server has an IP address of 10.10.10.1 (the default) type the following:  
`http://10.10.10.1/incinerator`

The Resource Manager appears in the browser.

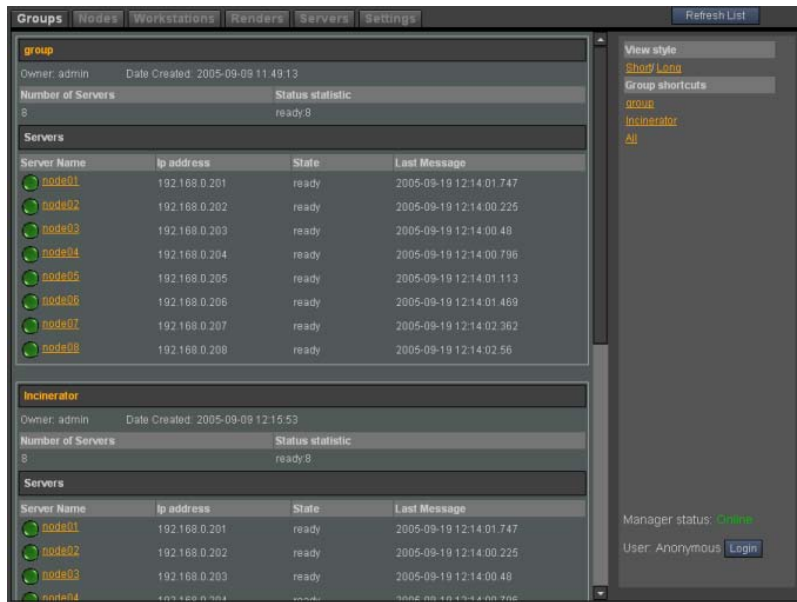

- 3 By default, the Resource Manager operates as user “anonymous”. To log in under your own account, click the Login button.

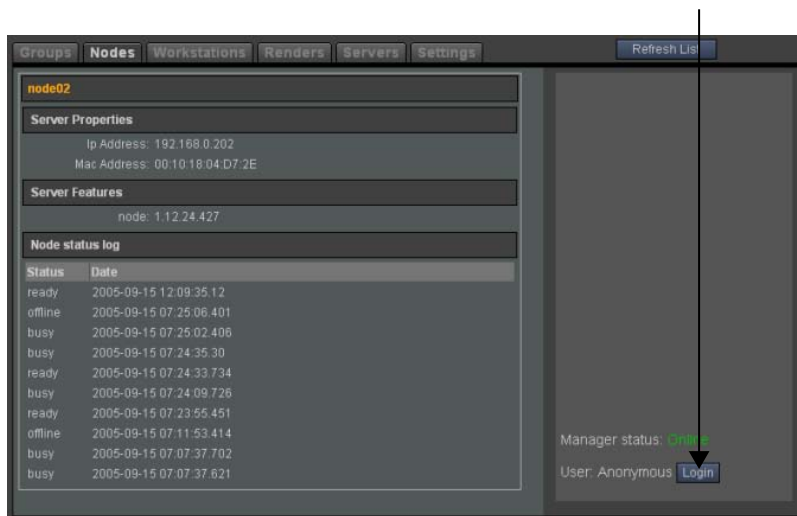

The User Authentication panel opens in the right-hand column.

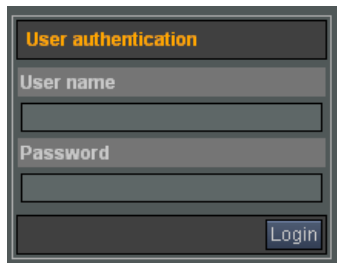

- 4 Enter your user name and password and click Login.  
The default administrator account user name is *admin* and its default password is *admin*.

---

**NOTE** Values for the user name and password are case-sensitive.

---

Once logged in, your account name appears in the lower-right corner of the Resource Manager.

- 5 If you are the system administrator logging for the first time, you may wish to perform one of the following operations:
  - Secure the *admin* user account by changing the default password. See [Modifying User Accounts](#).
  - Limit the functionality of the “anonymous” user account. See [Managing Permissions](#) on page 69.
  - Create new users. See [Creating a New User Account](#) on page 68.
- 6 Once finished, end your session by clicking the Logout button.

# Understanding the User Interface

The Resource Manager organizes information and activities into tabs, as described in the following table.

Tab	Description
Group	Allows you to view, add, delete and modify node groups. Node groups listed here appear in Lustre's Clustre menu. To take advantage of inline rendering, the Lustre workstation must connect to an Incinerator node group. See <a href="#">Using Incinerator for Real-Time Playback</a> on page 79.
Nodes	Lists all Incinerator nodes in the system, and their status.
Workstations	Presents information on all Lustre workstations on the Incinerator system, including status and log details.
Renders	Lists the Burn jobs currently being processed. Note that this feature is currently deprecated. To monitor Burn jobs, use the Backburner Monitor instead. See the <i>Autodesk Lustre User Guide</i> .
Servers	Presents information on Lustre Media Servers in the system, including status and log details. Can be used to stop and restart the <i>browseD</i> daemon.
Settings	Contains tools for managing user accounts, permissions, and Resource Manager preferences.

## Managing Node Groups

From the Resource Manager, you can organize Incinerator nodes into groups, and manage existing node groups. Grouping nodes is an essential management task, since there must be at least one existing node group for Lustre to take advantage of inline rendering using Incinerator.

If you will also be using the Incinerator nodes to perform background rendering using Burn for Lustre, there are additional considerations. Inline rendering will always preempt any active Burn job. That is, the Burn job will automatically be paused when inline rendering is needed. If this results in excessive completion times for Burn jobs, consider creating a node group with fewer than the total number of available nodes. For example, if you have 8 Incinerator nodes, you could create a node group of 4 nodes for inline rendering, leaving 4 nodes outside the group, always available to service Burn jobs. In this way, the Burn jobs will not be preempted by Incinerator. Alternately, create a single node group consisting of all available nodes, and use the Backburner Manager to schedule Burn node availability to off-peak hours only.

Use the following table to locate the Incinerator Node task you want to perform.

To:	See:
Create a new Incinerator Node group.	<a href="#">Creating Incinerator Node Groups</a> on page 53.
Change the name or owner of an Incinerator Node group.	<a href="#">Modifying the Name or Owner of an Incinerator Node Group</a> on page 55.
Add Incinerator Nodes to or remove Incinerator Nodes from a group.	<a href="#">Modifying the Nodes Assigned to an Incinerator Node Group</a> on page 56.
Delete a group.	<a href="#">Deleting Incinerator Node Groups</a> on page 58.
Start or stop the <i>renderd</i> daemon running on a single node or group of nodes.	<a href="#">Stopping and Starting Incinerator Daemons</a> on page 64.

# Creating Incinerator Node Groups

You must create an Incinerator Node group with the Resource Manager to run Incinerator on the Lustre workstation. You can also use Incinerator Node groups to quickly stop or restart multiple nodes for maintenance.

To create an Incinerator Node group, you first create the group and then add nodes to it.

## To create an Incinerator Node group:

- 1 Navigate to the Groups tab in the Resource Manager.

A list of groups on the Incinerator system appears. You create new groups using the Create New Server Group area in the Resource Manager.

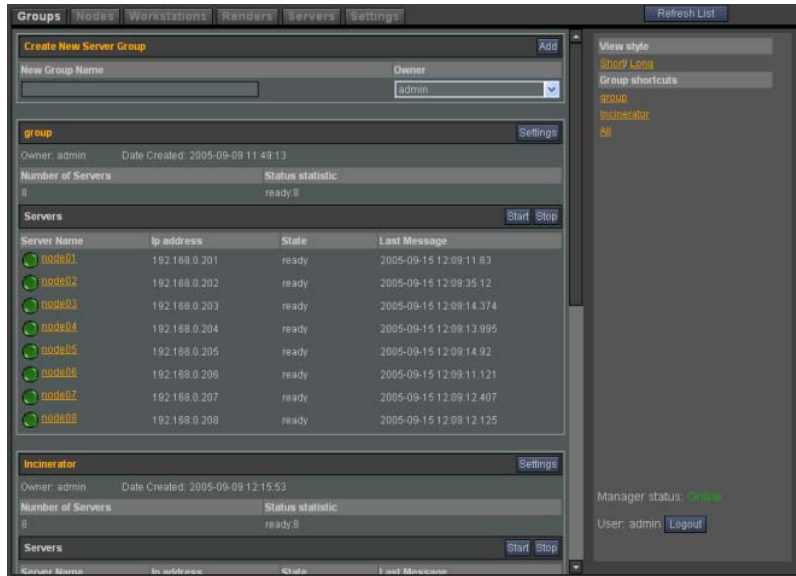

---

**TIP** To view a summary of all Incinerator Node groups on the Incinerator system, go to View Style at the right of the Resource Manager and click Short.

---

- 2 Enter the name of the new Incinerator Node group in the New Group Name field.
- 3 Optional: Enter the name of the user who administers the group in the Owner field.  
Rights to administer groups are not limited to the group owner. Setting an owner does not restrict the rights of other users for that group. The value just indicates ownership.
- 4 Click Add.

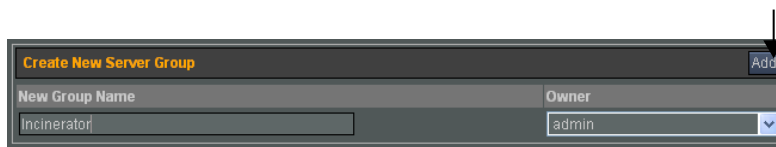

The Incinerator Node group is created and appears in the following location:

- The main list of all Incinerator Node groups.
- The Group Shortcuts area at the right of the Incinerator Resource Manager.

---

**TIP** To quickly scroll to a Incinerator Node group, click the group's name in the Group Shortcuts area.

---

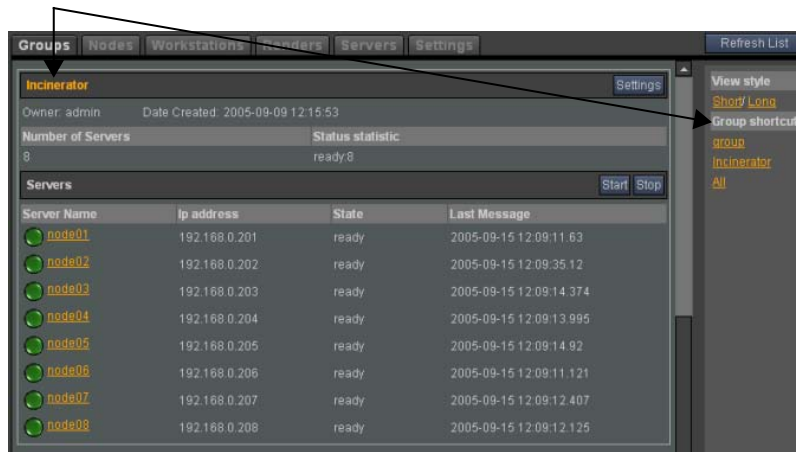

By default, new Incinerator Node groups have no nodes assigned to them. Next, add Incinerator Nodes to the new group.

- 5 Click Settings beside the group's name.

The Resource Manager displays the name, owner, and Incinerator Nodes assigned to the group (if any). Incinerator Nodes on the system are organized in the following three lists.

List	Contents
All Nodes	Shows all nodes on the Incinerator system.
Unassigned Nodes	Shows nodes not currently assigned to a group.
Nodes in Group	Shows nodes assigned to the current group. This list is empty for new groups

- 6 From the Unassigned Nodes list, select the Incinerator Nodes for the new group, and then click Add. The Incinerator Nodes are added to the new group. In the example below, all eight nodes are added to the group.

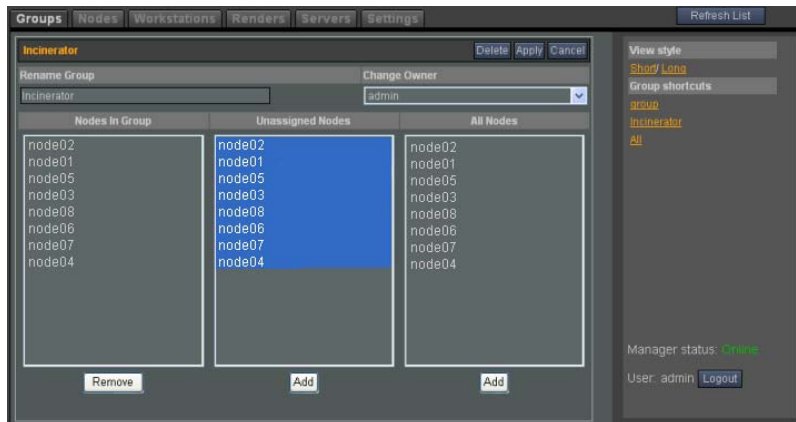

**NOTE** You can also add Incinerator Nodes from the All Nodes list to the current group. However, adding the same Incinerator Node to multiple groups is not recommended.

- 7 Click Apply.

The assigned Incinerator Nodes appear with the group in the list.

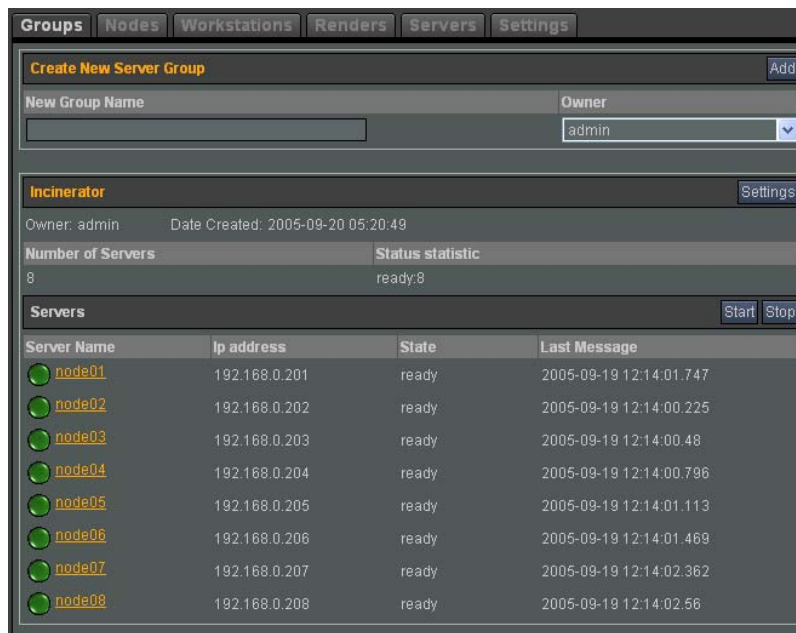

---

**TIP** Click Refresh List if the group does not appear to change.

---

## Modifying the Name or Owner of an Incinerator Node Group

Modify the name or owner of an Incinerator Node using the following procedure.

Changing the owner of a group does not restrict the rights of other users for that group. The value just indicates ownership.

**To modify the name or owner of an Incinerator Node group:**

- 1 Navigate to the Groups tab in the Resource Manager.  
A list of all Incinerator Node groups on the Incinerator system appears.
- 2 Locate the group to be modified by doing one of the following:
  - Scroll through the list of all Incinerator Node groups.
  - Click the name of the Incinerator Node group in the Group Shortcuts area at the right side of the Resource Manager.
- 3 Click Settings.

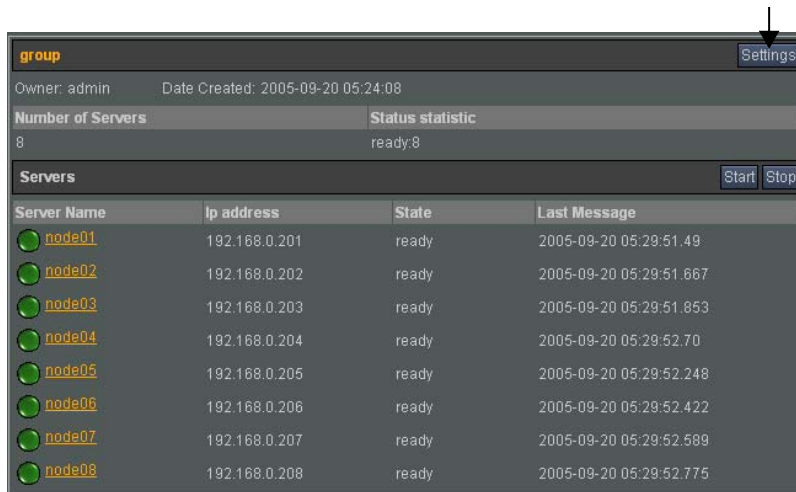

The Resource Manager displays the name, owner, and Incinerator Nodes assigned to the group. Use these controls to modify the group's name or owner, as well as the Incinerator Nodes assigned to the group.

- 4 In the Change Group Name field, enter a new name for the group.
- 5 From the Change Owner list, choose a new group owner.
- 6 Click Apply.

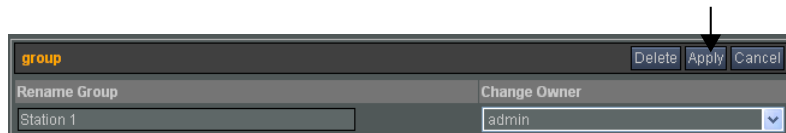

The group's name or owner is updated.

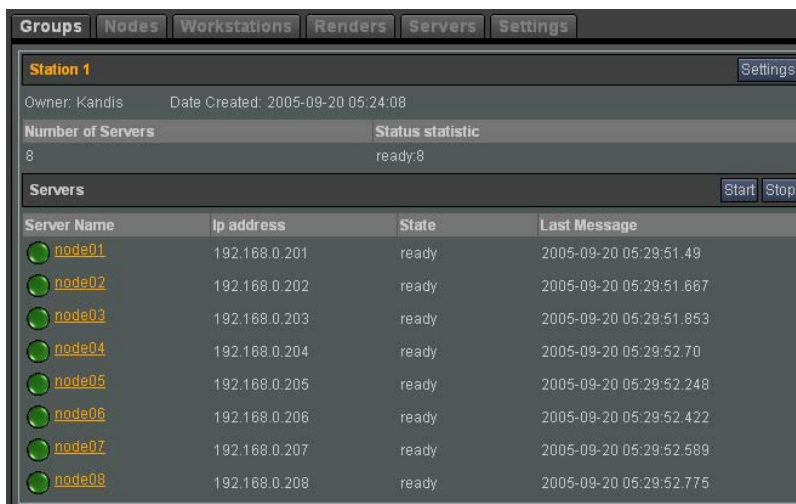

## Modifying the Nodes Assigned to an Incinerator Node Group

Add Incinerator Nodes to, or remove Incinerator Nodes from, a group using the following procedure.

**To modify the nodes assigned to an Incinerator Node group:**

- 1 Navigate to the Groups tab in the Resource Manager.  
A list of all Incinerator Node groups on the Incinerator system appears.
- 2 Locate the group to be modified by doing one of the following:
  - Scroll through the list of all Incinerator Node groups.
  - Click the name of the Incinerator Node group in the Group Shortcuts area at the right side of the Incinerator Resource Manager.
- 3 Click Settings.

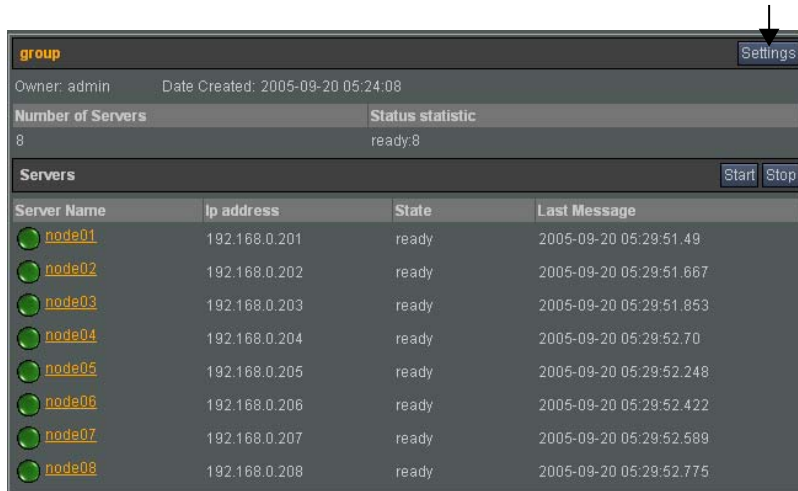

The Resource Manager displays the name, owner, and Incinerator Nodes assigned to the group. Use these controls to modify the Incinerator Nodes assigned to the group, as well as modify the group's name or owner.

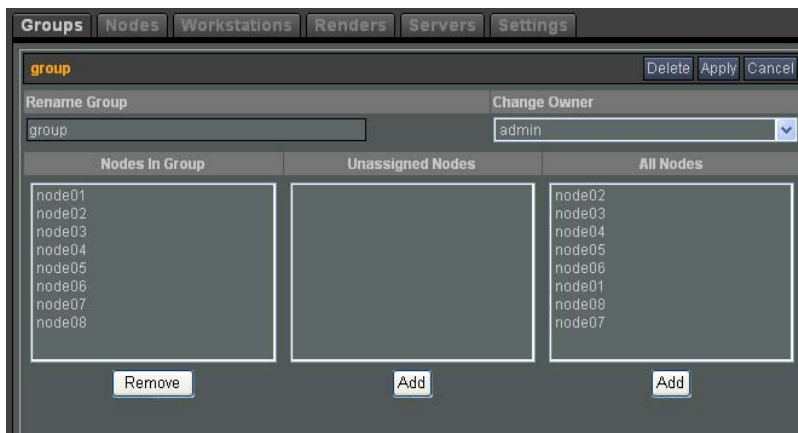

- 4 Modify the Incinerator Nodes in the group by doing either of the following:
  - To add Incinerator Nodes to the group, select the Incinerator Nodes from the Unassigned Nodes list and click Add.
  - To remove Incinerator Nodes from the group, select the Incinerator Nodes from the Nodes In Group list and click Remove.

The list of Incinerator Nodes in the group is updated. In the example below, node 05, 06, 07, and 08 are removed from the group.

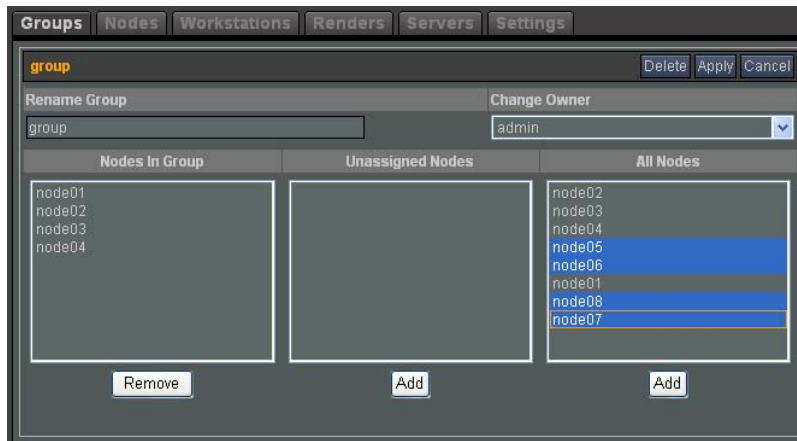

**NOTE** You can also add Incinerator Nodes from the All Nodes list to the current group. However, adding the same Incinerator Node to multiple groups is not recommended.

- 5 Click Apply.

The Incinerator Node group is updated in the Resource Manager.

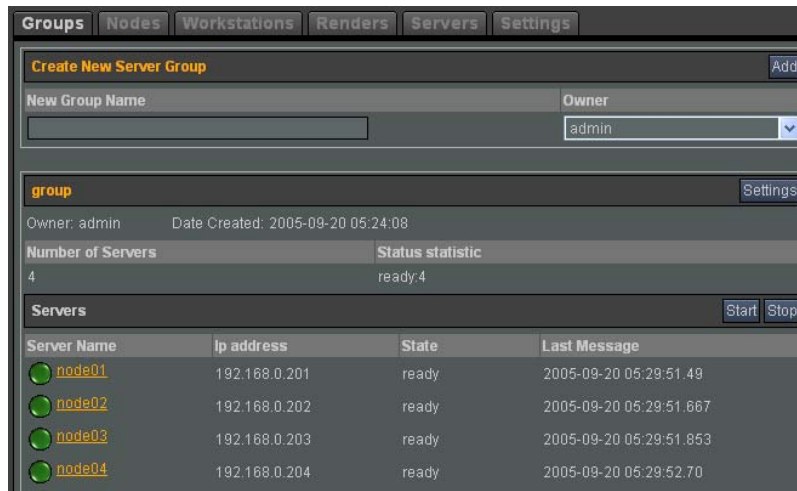

## Deleting Incinerator Node Groups

Use the Incinerator Resource Manager to delete an Incinerator Node group when it is not needed anymore. When you delete an Incinerator Node group, its Incinerator Nodes can be assigned to other groups through the Resource Manager.

**To delete an Incinerator Node group:**

- 1 Navigate to the Groups tab in the Resource Manager.  
A list of all Incinerator Node groups on the Incinerator system appears.
- 2 Locate the group to be modified by doing one of the following:
  - Scroll through the list of all Incinerator Node groups.
  - Click the name of the Incinerator Node group in the Group Shortcuts area at the right side of the Incinerator Resource Manager.

- 3 Click Settings.



- 4 Click Delete.

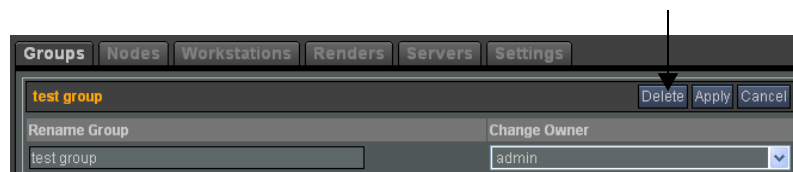

You are prompted to confirm the group's deletion.

- 5 Click OK to delete the group.

The Incinerator Node group is deleted and the list of Incinerator Node groups reappears in the Resource Manager.

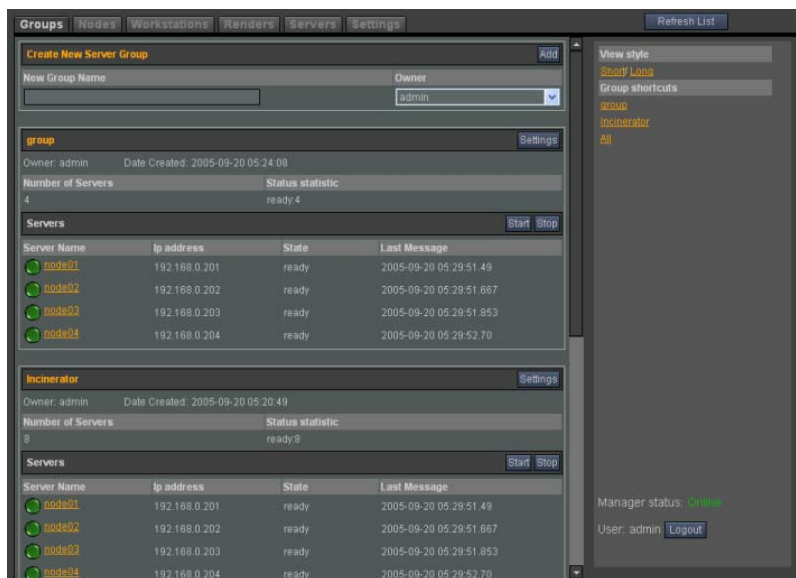

Any Incinerator Nodes that were used exclusively by the group are freed for reassignment. To reassign these Incinerator Nodes, see [Modifying the Nodes Assigned to an Incinerator Node Group](#) on page 56.

## Monitoring Incinerator Nodes

You can view the status and details for all Incinerator Nodes on the Incinerator system.

All Incinerator Nodes run the *renderd* daemon to process frames for real-time playback on the Lustre workstation. When you view the status of nodes, you see the status of the *renderd* daemon running on those nodes.

**To view the status of Incinerator Nodes on the Incinerator system:**

- 1 Navigate to the Nodes tab in the Resource Manager.

A list of all Incinerator Nodes on the Incinerator system appear in the Resource Manager.

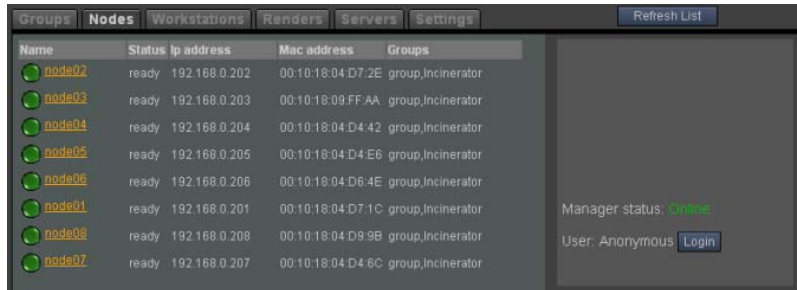

The following table presents the information found in the Nodes tab:

Column	Description
Name	The node name, of the form node#, as assigned when installing the customized Autodesk distribution of Red Hat Enterprise Linux.
Status	Status of the node ( <i>renderd</i> daemon): absent: No longer seen by the Resource Manager, possibly down. ready: Inactive. busy: Currently working on a render.
IP Address	IP address of the node (10.10.10.10x by default).
MAC Address	MAC address of the network interface card installed on the node.
Groups	A list of the node groups to which the node belongs.

- 2 Click a node name to open the details panel.

The details panel appears.

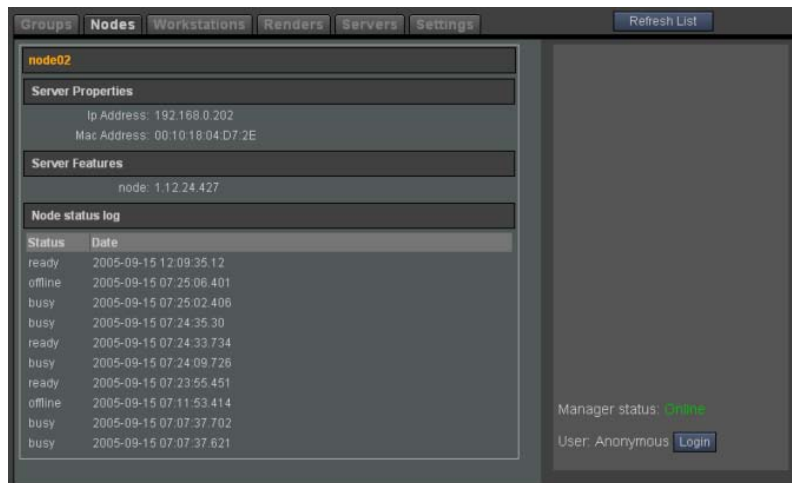

The following table describes the information found in the node details panel.

Item	Description
Server Properties	The IP Address and MAC address of the node.
Server Features	The <i>renderd</i> version installed on the node.
Node status log	Recent status messages for the node ( <i>renderd</i> daemon).

**TIP** You also use this panel to stop or restart the *renderd* daemon on an Incinerator Node. See [Stopping and Starting Incinerator Daemons](#) on page 64.

- 3 To return to the list of nodes, click the Nodes tab.

## Monitoring Lustre Media Servers

You can view the status and details for all Lustre Media Servers on the Incinerator system.

All Lustre Media Servers run the *BrowseD* daemon to provide access to frames from the storage attached to it. When you view the status of servers, you see the status of the *BrowseD* daemon running on the server.

The *BrowseD* daemon can also run on the workstation for background rendering. If the workstation is running *BrowseD*, it will also appear on the Servers tab of the Incinerator Resource Manager.

**To view the status of Lustre Media Servers on the Incinerator system:**

- 1 Navigate to the Servers tab in the Resource Manager.

A list of all Lustre Media Servers on the Incinerator system appears in the Resource Manager.

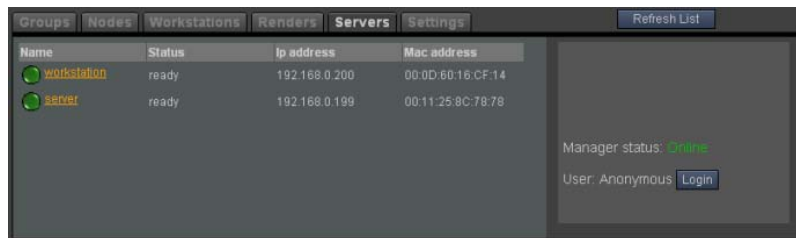

The following table presents the information found in the Servers tab:

Column	Description
Name	The Lustre Media Server name (host name).
Status	Status of the Lustre Media Server ( <i>BrowseD</i> daemon): offline: No longer seen by the Resource Manager, possibly down. This can occur when the Lustre Media Server has previously connected to this Resource Manager (that is, it is registered in the database), but is not connected now. ready: Connected.
IP Address	IP address of the Lustre Media Server (10.10.10x by default).
MAC Address	MAC address of the network interface card installed on the server.

- 2 Click a Lustre Media Server name to open the details panel.

The details panel appears.

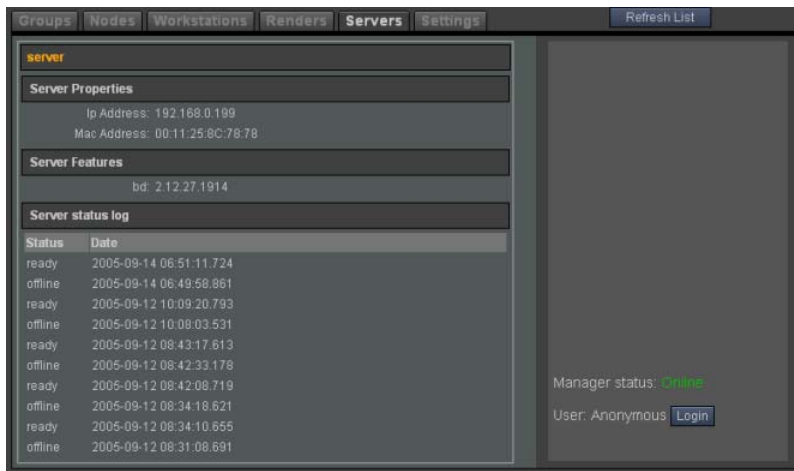

The following table describes the information found in the servers details panel.

Item	Description
Server Properties	The IP Address and MAC address of the server.
Server Features	The <i>BrowseD</i> version installed on the server.
Server status log	Recent status messages for the server ( <i>BrowseD</i> daemon).
browsed log	Recent log messages for the server ( <i>BrowseD</i> daemon).

**TIP** You can also use this panel to stop or restart the *BrowseD* daemon on the Lustre Media Server. See [Stopping and Starting Incinerator Daemons](#) on page 64.

- 3 To return to the list of Lustre Media Servers, click the Servers tab.

## Monitoring Lustre Workstations

You can view the status and details for all Lustre workstations on the Incinerator system.

The Workstation status in the Incinerator Resource Manager indicates the status of the Lustre application on that workstation. It does not indicate the overall status of the workstation.

**To view the status of Lustre workstations on the Incinerator system:**

- 1 Navigate to the Workstations tab in the Resource Manager.

A list of all Lustre workstations on the Incinerator system appears in the Resource Manager.



The following table presents the information found in the Workstations tab:

Column	Description
Name	The workstation name (host name).
Status	Status of workstation (Lustre application): offline: No longer seen by the Resource Manager, possibly down. This can occur when the Lustre application has previously connected to this Resource Manager (that is, it is registered in the database), but is not connected now. running: Connected to the Resource Manager.
IP Address	IP address of the workstation (10.10.10.20x by default).
MAC Address	MAC address of the network interface card installed on the workstation.

## 2 Click a workstation name to open the details panel.

The details panel appears.

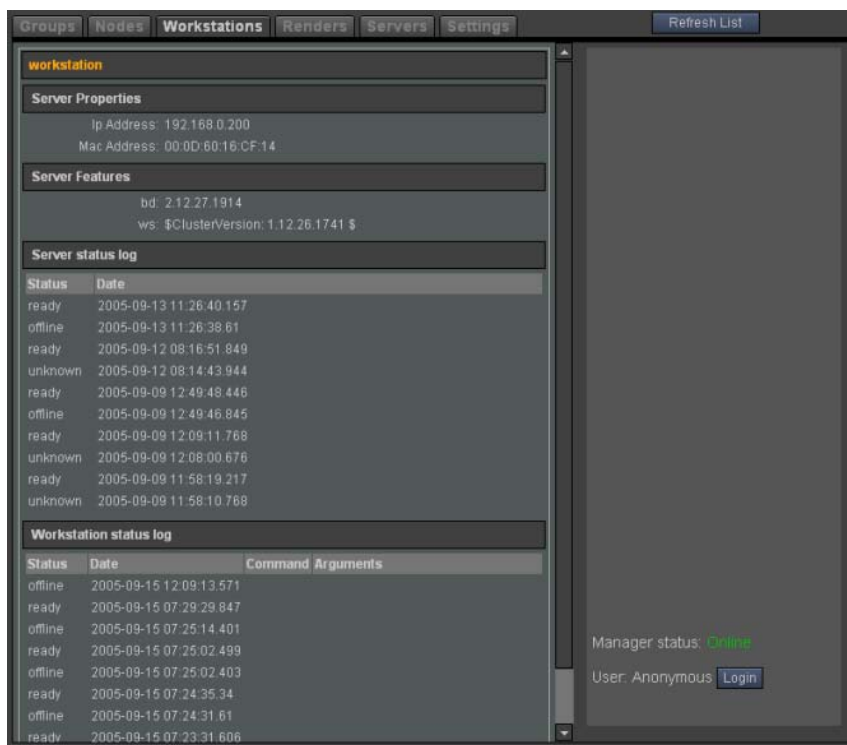

The following table describes the information found in the servers details panel.

Item	Description
Server Properties	The IP Address and MAC address of the workstation.
Server Features	The Incinerator-related software running on the workstation: bd: <i>BrowseD</i> . ws: Lustre application.
Server status log	Recent status messages for any <i>BrowseD</i> daemon running on the workstation. Status messages for the <i>BrowseD</i> daemon running on the Lustre Media Server are found on the Servers tab. See <a href="#">Monitoring Lustre Media Servers</a> on page 61.

Item	Description
Workstation status log	Recent log messages for the Lustre application running on the workstation.
browsed log	Recent detailed status messages for any <i>BrowseD</i> daemon running on the workstation.
renderdclient log	Information relating to the Lustre application's recent connections to the Incinerator nodes.

- To return to the list of workstations, click the workstations tab.

## Monitoring Command-Line Rendering

The Renders tab on the Incinerator Resource Manager identifies Incinerator system components that are currently running the command-line renderer.

With the command-line renderer, you can render final frames using the Incinerator Nodes. The command-line renderer manages the process and writes the rendered frames to the file system.

---

**NOTE** This feature has been deprecated. Please use the Backburner Monitor instead.

---

To view the status of command-line rendering on the Incinerator system:

- Navigate to the Renders tab in the Resource Manager. Machines running the command-line renderer appear in the Resource Manager with the Status set to “busy”.



## Stopping and Starting Incinerator Daemons

You can stop and restart Incinerator daemons on all system components using the Resource Manager.

- When you stop or start an Incinerator Node group, you stop or start the *renderd* daemon all nodes in the group. This has the same effect as logging in to each Incinerator Node in the group and running the `/etc/init.d/renderd_2009.SP7 stop` or `/etc/init.d/renderd_2009.SP7 start` commands.
- When you stop a node, you stop the *renderd* daemon on that node. This has the same effect as logging in to an Incinerator Node and running the `/etc/init.d/renderd_2009.SP7 stop` or `/etc/init.d/renderd_2009.SP7 start` commands.
- When you stop or start a server, you stop or start the *BrowseD* daemon on the Lustre Media Server or workstation. This has the same effect as logging in to a Lustre Media Server and running the `/etc/init.d/browsed_2009.SP7 stop` or `/etc/init.d/browsed_2009.SP7 start` commands.

---

**NOTE** To be able to start or stop a daemon on any machine, the daemon must have the *chkconfig* flag set to on.

---

---

**WARNING** Stopping daemons halts all operations without completing or saving. Be sure that the Lustre application and daemons are idle and all work has been saved before you stop them. Failure to do so may cause loss of work.

---

**To stop and restart Incinerator daemons from the Resource Manager:**

- 1 Navigate to the tab for the daemons you want to stop or start.



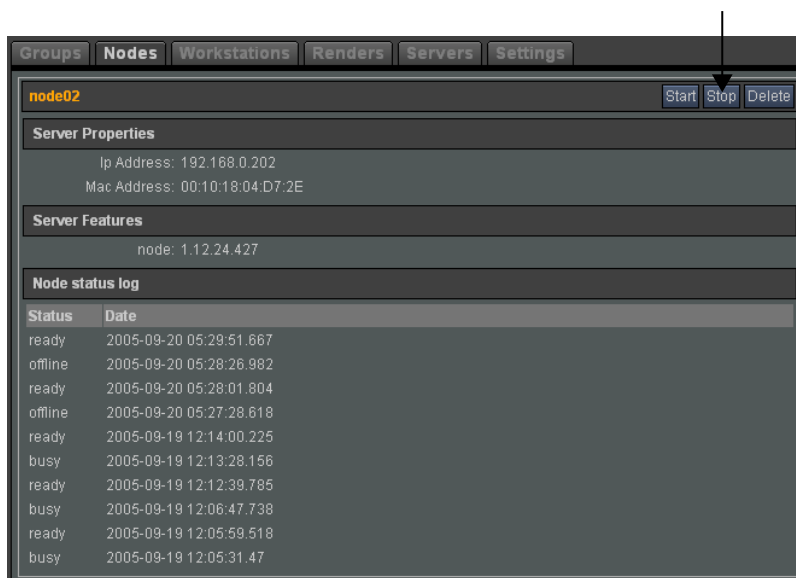

Select:	To:
Groups	To view all the Incinerator Node groups.
Nodes	To view all Incinerator Nodes on the Incinerator system.
Servers	To view all machines running the <i>BrowseD</i> daemon, including the Lustre Media Server, on the Incinerator system.

A list of all Incinerator Nodes, Incinerator Node groups, or Lustre Media Servers on the Incinerator system appears.

- 2 Click the Incinerator Node, Incinerator Node group, or Lustre Media Server to be stopped from the list. Details for the selection appear. Use the Stop and Start buttons in the Resource Manager to control the node or server.
- 3 Click Stop to stop the Incinerator Node, Incinerator Node group, or Lustre Media Server.



The Incinerator Node, Incinerator Node group, or Lustre Media Server is stopped and its status changes in the Resource Manager.

Groups					Nodes					Workstations					Renders					Servers					Settings				
Name	Status	Ip address	Mac address	Groups																									
 node02	offline	192.168.0.202	00:10:18:04:D7:2E	group,Incinerator																									
 node03	ready	192.168.0.203	00:10:18:09:FF:AA	group,Incinerator																									
 node04	ready	192.168.0.204	00:10:18:04:D4:42	group,Incinerator																									
 node05	ready	192.168.0.205	00:10:18:04:D4:E6	group,Incinerator																									
 node06	ready	192.168.0.206	00:10:18:04:D6:4E	group,Incinerator																									
 node01	ready	192.168.0.201	00:10:18:04:D7:1C	group,Incinerator																									
 node08	ready	192.168.0.208	00:10:18:04:D9:9B	group,Incinerator																									
 node07	ready	192.168.0.207	00:10:18:04:D4:6C	group,Incinerator																									

- Click Start to restart the Incinerator Node, Incinerator Node group, or Lustre Media Server. The Incinerator Node, Incinerator Node group, or Lustre Media Server is restarted and its status changes in the Resource Manager.

---

**TIP** Click Refresh List if the status does not appear to change.

---

## Deleting Duplicate Entries

When an Incinerator system component starts up, it is tracked by its IP address in the Resource Manager database. If you change the IP address of the component, the original IP address of the component remains in the database, creating two entries for the same component in the Resource Manager.

If you change the IP address of a component on the Incinerator system, you must delete the component with the old IP address from the Resource Manager. Otherwise, duplicate entries for the same device appear. You can delete duplicate Lustre Media Servers, workstations, and Incinerator Nodes.

---

**NOTE** If you delete the wrong component, just restart the daemon on the Lustre Media Server or node, or restart the workstation, and the Resource Manager is updated to display the active component.

---

### To delete duplicate Lustre Media Servers, workstations, and Incinerator Nodes:

- Navigate to the tab for the components you want to delete.

Select:	To:
Groups	To view all the Incinerator Node groups.
Nodes	To view all Incinerator Nodes on the Incinerator system.
Servers	To view all machines running the <i>BrowseD</i> daemon, including the Lustre Media Server, on the Incinerator system.

A list of all Incinerator Nodes, Incinerator Node groups, or Lustre Media Servers on the Incinerator system appears.

- Click the Incinerator Node, Lustre Media Server, or workstation to be deleted from the list.
- Click Delete to delete the Incinerator Node, workstation, or Lustre Media Server.

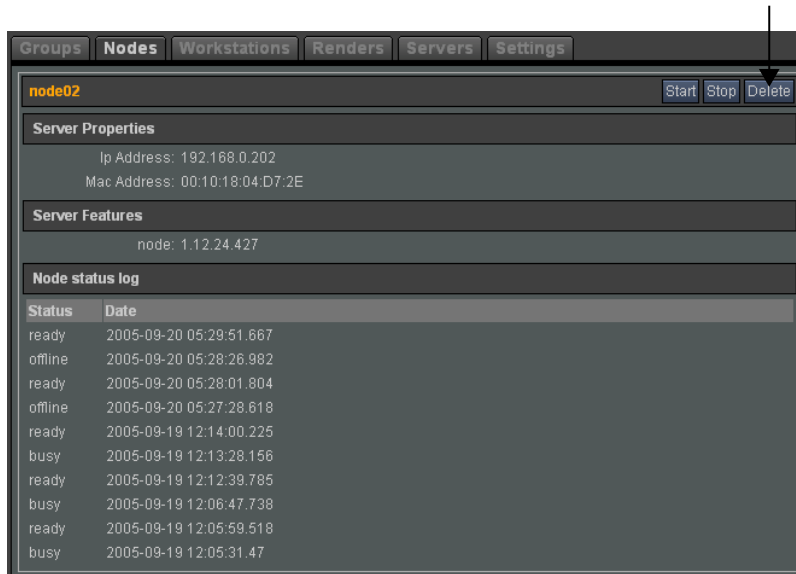

A dialog box opens and asks you to confirm that the component will be deleted.

- 4 Click OK to delete the Incinerator Node, workstation, or Lustre Media Server. The component is removed from the Resource Manager tabs.

## Managing Resource Manager User Accounts

Tools on the Settings tab allow you control user rights by setting up accounts for each user.

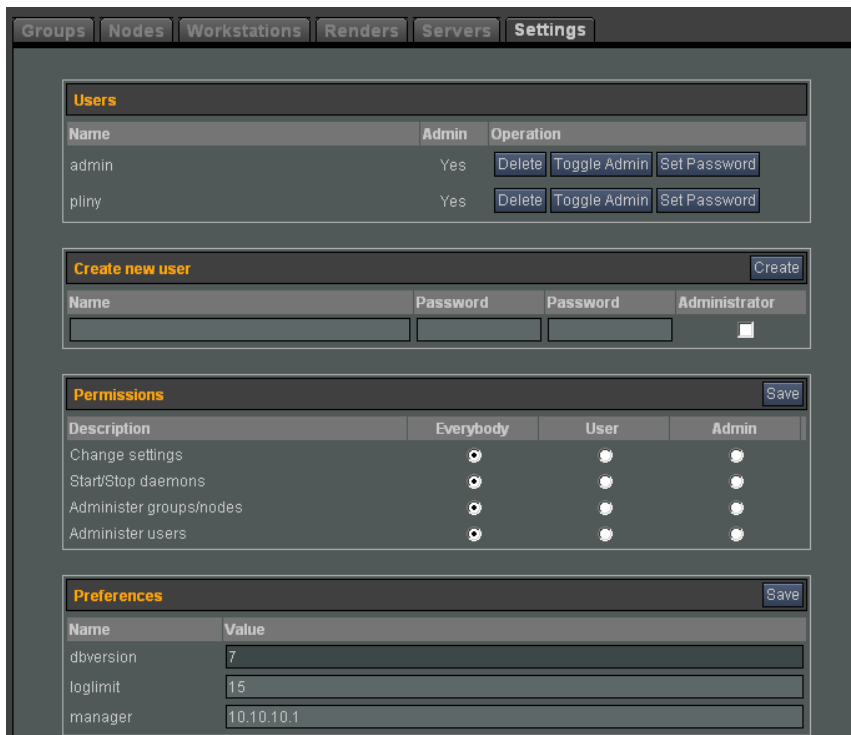

---

**NOTE** User accounts and permissions for the Incinerator Resource Manager are different from Linux user accounts. You create and manage Resource Manager user accounts in the Resource Manager.

---

The following table describes the information found in the Settings tab.

Area	Description
Users	View all users in the Incinerator Resource Manager database and whether or not they have administration privileges. From here you can delete users, toggle <i>admin</i> privileges and set new passwords.
Create New User	Add new users and quickly assign them admin privileges.
Permissions	Set permission levels for the different tasks: Everybody: All users, including the “anonymous” user—that is, even users that are not logged in. User: Logged-in users. Admin: Administrators only.
Preferences	View the Incinerator Resource Manager database version. From here you can set the number of messages retained by the logs (and presented in the UI), and the IP address of the Resource Manager (10.10.10.1 by default).

---

## Creating a New User Account

Create user accounts to control the rights that users have on the Incinerator system.

---

**NOTE** Values for the user name and password are case-sensitive. Be sure to use a consistent convention for choosing user names and passwords.

---

To create a new user account:

- 1 Navigate to the Settings tab in the Resource Manager.
- 2 In the Create new user panel, type the user name in the Name field.

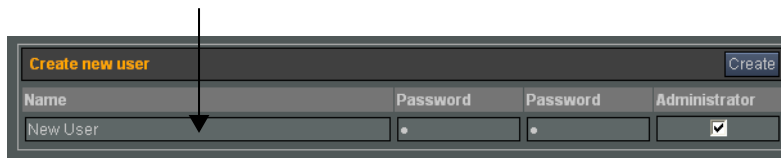

- 3 Type the user's password in the Password field and confirm the password by typing it again in the second Password field.
- 4 To give this user administrator rights, select the Administrator option.
- 5 Click Create.

## Modifying User Accounts

Modify user accounts in the Users area of the Settings tab.

- 1 Navigate to the Settings tab in the Resource Manager.
- 2 In the Users panel, click a button next to the user interest:
  - **Delete:** Permanently remove the selected user account. You are asked to confirm the action.

---

**WARNING** You cannot undo the deletion of a user.

---

- **Toggle Admin:** Assign/remove administrator privileges from the selected user.
- **Set Password:** Give the user a new password. Passwords are case-sensitive.

## Managing Permissions

When you start the Incinerator Resource Manager you are identified as the “anonymous” user by default. This user, as well as all other users that log in to the Resource Manager, can view the status of groups, nodes, workstations, and renders. However, the ability to perform other tasks in the Resource Manager can be limited to selected users.

From the Settings tab, you can limit the following tasks to selected users:

**Change settings** Manage permissions from the Settings tab.

**Start/Stop Daemons** Start and stop the *BrowseD* and *renderd* daemons from the Groups, Nodes, Workstations, and Servers tabs.

**Administer groups/nodes** Create, modify, and delete groups and nodes from the Groups and Nodes tabs, as well as delete duplicate nodes, workstations, and Lustre Media Servers from the Nodes, Workstations, and Servers tabs.

**Administer users** Create and delete users from the Settings tab.

To create an Incinerator Resource Manager user account, see [Creating a New User Account](#) on page 68. To add administrator rights to a user account, see [Modifying User Accounts](#).

### To manage permissions:

- 1 Log in to the Resource Manager with a user account that has permission to administer users. See [Logging In and Logging Out of the CEV\\_ProdName\\_CEV Resource Manager](#).
- 2 Click the Settings tab.
- 3 Identify the tasks that require specific user permissions.

Select:	To:
Everybody	Enable any user, including the “anonymous” user, to perform the task.
User	Limit the tasks to users that are logged in to the Resource Manager. The anonymous user cannot perform these tasks.
Admin	Limit the task to administrators only.

- 4 Click the Save button in the Permissions panel to save your changes.

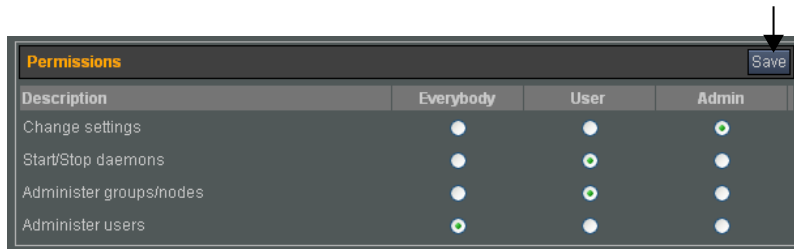



# Licensing and Starting Incinerator

# 9

## Topics in this chapter:

- [Workflow for Licensing, Configuring, and Using Incinerator](#) on page 71
- [Determining the License Codes You Require](#) on page 72
- [Obtaining the Imhostid Strings](#) on page 72
- [Requesting Incinerator License Codes](#) on page 73
- [Creating the License File for the License Server](#) on page 73
- [Starting the License Server](#) on page 74
- [Installing the BrowseD License on the Lustre Media Server](#) on page 74
- [Installing Incinerator Node Licenses](#) on page 75
- [Installing the Workstation License](#) on page 76
- [Configuring Incinerator Daemons](#) on page 76
- [Using Lustre with Incinerator](#) on page 78

## Workflow for Licensing, Configuring, and Using Incinerator

The recommended steps for licensing, configuring, and using Incinerator are as follows.

Step:	Refer to:
1. Determine the license codes you require.	<a href="#">Determining the License Codes You Require</a> on page 72.
2. Obtain the <i>Imhostid</i> strings of the Lustre Media Server and workstation.	<a href="#">Obtaining the Imhostid Strings</a> on page 72.
3. Request license codes from the Autodesk Licensing Department.	<a href="#">Requesting Incinerator License Codes</a> on page 73.

Step:	Refer to:
4. After you receive your license codes, set up the license file for the license server.	<a href="#">Creating the License File for the License Server</a> on page 73.
5. Start the license server.	<a href="#">Starting the License Server</a> on page 74.
6. Create the <i>BrowseD</i> license file on the Lustre Media Server.	<a href="#">Installing the BrowseD License on the Lustre Media Server</a> on page 74.
7. Install the Incinerator node licenses.	<a href="#">Installing Incinerator Node Licenses</a> on page 75.
8. Install the workstation license.	<a href="#">Installing the Workstation License</a> on page 76.
9. (Optional) configure Incinerator daemons.	<a href="#">Configuring Incinerator Daemons</a> on page 76.
10. Start Lustre on the workstation and set up your project to use Incinerator.	<a href="#">Using Lustre with Incinerator</a> on page 78.

## Determining the License Codes You Require

You must license the following applications and daemons to run Lustre with Incinerator.

Application/Daemon	Enables	License location:
<i>BrowseD</i> daemon	High-speed frame transfers over InfiniBand.	Lustre Media Server
<i>renderd</i> daemon	Inline rendering on Incinerator Nodes	Lustre Media Server
(Optional) Burn for Lustre	Background rendering on Incinerator nodes or dedicated background rendering nodes	Lustre Media Server
Lustre with Incinerator for the Lustre Master Station	Lustre application with Incinerator features	Lustre Master Station
Lustre with Incinerator for the Lustre Station	Lustre application with Incinerator features	Lustre Station

**NOTE** Licenses for *renderd* and Burn for Lustre are managed by a license server you install on the Lustre Media Server.

## Obtaining the *Imhostid* Strings

To obtain license codes for Incinerator, you must obtain the *Imhostid* for the Lustre Media Server and for the Lustre workstation.

**To obtain the *Imhostid* for Incinerator:**

- 1 Log in to the Lustre Media Server as root and type:

```
Imhostid
```

A message appears that includes a line indicating the *Imhostid* of the machine. For example (your value will differ):

- The FLEXlm host ID of this machine is "<lmhostid>"
- 2 Write down the *lmhostid*.
  - 3 Repeat the preceding steps on the workstation.

## Requesting Incinerator License Codes

You can obtain license codes for Incinerator from the Autodesk Media and Entertainment Licensing Department by e-mail or telephone.

---

**NOTE** For emergencies, you can acquire an immediate temporary license code by going to the Autodesk Registration Web page at [www.autodesk.com](http://www.autodesk.com), clicking the Services & Support link, selecting your product, then clicking Request a Short-term License, and following the step-by-step instructions. A 4-day license code is e-mailed to the address you provide.

---

### To obtain license codes

- 1 Send the *lmhostid* of the Lustre Media Server and workstation to the Autodesk Licensing Department using one of the following two methods:
  - Send a request by e-mail to [me.licensing@autodesk.com](mailto:me.licensing@autodesk.com). Make sure to include the *lmhostid* strings of the Lustre Media Server and workstation machines.
  - Speak to a licensing representative by calling the Licensing Department toll-free in North America at 1-800-925-6442 between 8 AM and 8 PM EST. Outside of North America, call 1-514-954-7199.
- 2 Once you receive the license codes from the License Department, install and configure the license server.

## Creating the License File for the License Server

The license server runs on the Lustre Media Server and manages the licenses for the *renderd* daemon running on each Incinerator Node. If you configure background rendering, it also manages the Burn for Lustre licenses for each node.

The license server is automatically installed when you install the Lustre Media Server software.

After you receive your license codes, create the `/usr/discreet/licserv/licenses/DL_license.dat` license file on the Lustre Media Server, and enter the license information received from the Autodesk Licensing Department into it.

The license information contains keywords that identify the license server, as well as the license strings for the *renderd* and Burn for Lustre features.

Keyword	Description
SERVER	Specifies the hostname of the license server from which to obtain the license, followed by its MAC address.
VENDOR	Specifies the daemon that is serving the license.
USE_SERVER	Indicates whether the system should obtain its license from a license server.

To create the license server file on the Lustre Media Server:

- 1 Log in as root to the Lustre Media Server.
- 2 Navigate to the licenses directory by typing:  
**cd /usr/discreet/licserv/licenses**
- 3 If the file *DL\_license.dat* does not exist in the directory, create it by typing:  
**touch DL\_license.dat**
- 4 Open the file *DL\_license.dat* in a text editor.
- 5 Copy the SERVER, VENDOR, and USE\_SERVER keywords, as well as the license strings for the *renderd* feature and Burn for Lustre feature into the file. In the text you received from the Autodesk Licensing Department, the *renderd* feature appears as `lustre_incrdr_r_2009_L` and the Burn for Lustre feature appears as `lustre_bgrdr_r_2009_L`.

The contents of the license file should be similar to the following shortened example:

```
SERVER server 0011258D1A76
VENDORlustre
USE_SERVER
FEATURElustre_incrdr_r_2009_Llustre<...>
FEATURElustre_bgrdr_r_2009_Llustre<...>
```

- 6 Save and close the license file.

## Starting the License Server

After you create the license file for the license server, start it using the following procedure.

To start the license server:

- 1 Log into the Lustre Media Server as root.
- 2 In a shell, type:  
**/etc/init.d/license\_server start**

---

**NOTE** The license server starts/stops automatically when the machine is booted/shut down. You can stop and restart the server manually by running one of the following commands:

```
/etc/init.d/license_server stop
/etc/init.d/license_server restart
```

---

## Installing the BrowseD License on the Lustre Media Server

To install the BrowseD license, you must create the *BrowseD* license file on the Lustre Media Server, and copy the license string for the *BrowseD* feature into that file.

To configure the BrowseD license on the Lustre Media Server:

- 1 Log in as root to the Lustre Media Server.
- 2 Navigate to the licenses directory by typing:  
**cd /usr/local/flexlm/licenses**

- 3 If a file called *DL\_license.dat* does not exist in the directory, create it by typing:  
**touch DL\_license.dat**
- 4 Open the *DL\_license.dat* file in a text editor and copy and paste the license strings for the *BrowseD* feature into the file. The *BrowseD* feature appears as `lustre_browsed_ib_r_2009_L` in the text you receive from the Autodesk Licensing Department.  
 The resulting license file should contain a line similar to the following example:  

```
FEATURE lustre_browsed_ib_r_2009_L lustre <...>
```
- 5 Save and close the license file.
- 6 To enable the license, restart the *BrowseD* daemon by running the following command:  
**/etc/init.d/browsed\_2009.SP7 restart**

## Installing Incinerator Node Licenses

You must configure each Incinerator node to contact the license server on the Lustre Media Server to obtain its license. You do this by creating a license file on each Incinerator Node that identifies the license server running on the Lustre Media Server. The node contacts the license server to obtain its license.

Add three keywords to the license file to identify the license server: `SERVER`, `VENDOR`, and `USE_SERVER`. The Autodesk Licensing Department provides you with these keywords and the values associated with them when you request your license codes.

### To configure the Incinerator Node license:

- 1 As root on the Lustre Media Server, log in to the Incinerator Node by typing:  
**ssh <NODE\_HOSTNAME>**  
 where `<NODE_HOSTNAME>` is the host name of the node you are logging in to.  
 You must provide the user name and password to log in to the node. The default password for the root user is `password`.
- 2 Navigate to the licenses directory by typing:  
**cd /usr/local/flexlm/licenses**
- 3 Create a file called *DL\_license.dat* in the directory by typing:  
**touch DL\_license.dat**
- 4 Open the *DL\_license.dat* file in a text editor and copy and paste the `SERVER`, `VENDOR`, and `USE_SERVER` keywords from the license server license file into the Incinerator Node license file. The strings for these keywords are provided by the Autodesk Licensing Department.  
 The resulting license file should look similar to the following example:  

```
SERVER server 0011258D1A76
VENDOR lustre
USE_SERVER
```
- 5 Log off the node.
- 6 Repeat the preceding steps for each node.

# Installing the Workstation License

The licenses for the Lustre workstation running Incinerator are locked to the *lmhostid* of the workstation. The workstation license file must include a license for Lustre with Incinerator as well as licenses for two plug-ins.

---

**NOTE** You may require additional licenses for other Lustre optional features.

---

**To configure a workstation license:**

- 1 As root on the Lustre Media Server, log in to the workstation by typing:  

```
ssh <WS_HOSTNAME>
```

where `<WS_HOSTNAME>` is the host name of the workstation you are logging in to.  
You must provide the user name and password to log in to the workstation. The default password for the root user is `password`.
- 2 Navigate to the licenses directory by typing:  

```
cd /usr/local/flexlm/licenses
```
- 3 Create a file called *DL\_license.dat* in the directory by typing:  

```
touch DL_license.dat
```
- 4 Open the *DL\_license.dat* file in a text editor and copy and paste the feature license strings you received from the Autodesk Licensing Department into the file. The feature license strings are similar to the following shortened example:  

```
FEATURE lustre_incinerator_r_2009_L lustre <...>
```
- 5 Save and close the license file.

## Configuring Incinerator Daemons

There are several configuration files that control the behavior of Incinerator daemons.

Normally you do not need to edit these files. If you use any values different from the default (for example the IP addressing scheme), or change your Incinerator configuration after installation, you must modify these files.

### **init.config**

The *init.config* file configures communication between the Lustre workstation, the Incinerator Nodes, and the *BrowseD* daemon running on the Lustre Media Server. It is located in the `/usr/autodesk/lustre_application_version/` directory on the Lustre workstation and Incinerator nodes.

Fill in the values for the Port, Username, and Password keywords in the *init.config* file for Incinerator Nodes and the Lustre workstation. See [Software, Project, and User Configuration Files](#) on page 103.

---

**NOTE** If you make changes to the *init.config* file, restart the *BrowseD* daemon.

---

### **cmanagerd.conf**

The *cmanagerd.conf* file configures communication for *cmanagerd*, a daemon that allows you to view information about, and interact with, all the Incinerator system components through a single Web-based interface, the Incinerator Resource Manager. The *cmanagerd* daemon gathers information over the GigE

network from all the network components and stores this information in a database that is used to populate the fields in the Resource Manager Web interface. The *cmanagerd* daemon also sends commands to the components over the GigE network.

The *cmanagerd.conf* file indicates how the Incinerator system components communicate with *cmanagerd*, which runs on the Lustre Media Server. The *cmanagerd.conf* file is located on the Lustre Media Server in the */usr/autodesk/lustre\_<application\_version>/* directory.

The *cmanagerd.conf* file is configured with default values. If you use any configurations different from the default (like the network configuration), or change your Incinerator configuration after installation, you must modify this file.

---

**NOTE** After you make changes to the *cmanagerd.conf* file, restart the *cmanagerd* daemon.

---

Tag:	Contains:
<code>&lt;CMANAGERDREGISTER_INTERFACE&gt; &lt;eth0&gt; &lt;/CMANAGERDREGISTER_INTERFACE&gt;</code>	The network interface that is used by <i>cmanagerd</i> to connect to the database that displays information in the Resource Manager. This value should be the private Incinerator GigE network interface, which is <code>eth0</code> by default.
<code>&lt;CMANAGERDBROADCAST_INTERFACE&gt; &lt;eth0&gt; &lt;/CMANAGERDBROADCAST_INTERFACE&gt;</code>	The network interface that <i>cmanagerd</i> listens to for information broadcast by the system components. This value should be the private Incinerator GigE network interface, which is <code>eth0</code> by default.
<code>&lt;DATABASE_ADDRESS&gt; &lt;localhost&gt;&lt;/DATABASE_ADDRESS&gt;</code>	The location of the database that stores information about the system components. This value is the IP address of the Lustre Media Server, which is <code>localhost</code> by default.

## cmanagerdclient.conf

The *cmanagerdclient.conf* file enables Incinerator system components to communicate with *cmanagerd* running on the Lustre Media Server. This file is located on all Incinerator system components in the */usr/autodesk/lustre\_<application\_version>/* directory.

This file is configured with default values. If you use any values different from the default (for example the network configuration), or change your Incinerator configuration after installation, you must modify this file.

---

**NOTE** If you make changes to the *cmanagerdclient.conf* file on the workstation, you must restart Lustre on the workstation. If you make changes to the *cmanagerdclient.conf* file on an Incinerator Node, you must manually restart *renderd* on the node. If you make changes to *cmanagerdclient.conf* on the Lustre Media Server, you must manually restart *BrowseD* and *cmanagerd* on the Lustre Media Server.

---

Tag:	Contains:
<code>&lt;CMANAGERDCLIENT_BROADCAST_INTERFACE&gt; &lt;eth0&gt;&lt;/CMANAGERDCLIENT_BROADCAST_INTERFACE&gt;</code>	The network interface that is used by the component to send information to <i>cmanagerd</i> running on the Lustre Media Server. This value should be the GigE network interface, which is <code>eth0</code> by default.
<code>&lt;CMANAGERDCLIENT_CMANAGERD_ADDRESS&gt; &lt;10.10.10.1&gt;&lt;/CMANAGERDCLIENT_CMANAGERD_ADDRESS&gt;</code>	The GigE IP address of the component that is running <i>cmanagerd</i> , which is the Lustre Media Server. This value is <code>10.10.10.1</code> by default.

# Using Lustre with Incinerator

After you have licensed and configured all the components on your system, you are ready to begin using Lustre with Incinerator for real-time playback of your 2K 10-bit frames.

See the following table for the recommended steps for using Lustre with Incinerator.

Step:	Refer to:
1. Start Lustre.	<a href="#">Starting Lustre on the Workstation</a> on page 78.
2. Set up your project to use Incinerator.	<a href="#">Setting Up Lustre Project Management for Incinerator</a> on page 78.
3. Play back your shots.	<a href="#">Using Incinerator for Real-Time Playback</a> on page 79.

## Starting Lustre on the Workstation

Perform the following procedure to start Lustre on the workstation.

### To start Lustre on the workstation:

- 1 Log in as the Lustre user on the Lustre workstation.
- 2 Start the application by doing one of the following:
  - To start a Master Station, double-click the Lustre desktop icon, or open a terminal and type:  
**lustre**
  - To start an Assistant Station, open a terminal and type:  
**assistant**

The application launches and the user interface appears.

## Setting Up Lustre Project Management for Incinerator

This section provides an overview of setting up projects in Lustre with Incinerator. For detailed information on how to create a project, consult the Lustre help.

To use Incinerator on the Lustre workstation, at least the *Scans Full Home* path must point to the private Gigabit Ethernet (GigE) IP address of the Lustre Media Server.

Depending on your data management scheme, you can point the other project directories to the Lustre Media Server. Only the Scans Full Home must point to the Lustre Media Server for Incinerator.

The following project setup example illustrates how to append the GigE IP address of the Lustre Media Server to all your project paths.

Project Home	/mnt/md0/Projects
Scans Full Home	10.10.11.1:/mnt/md0/scans
Scans Half Home	10.10.11.1:/mnt/md0/scans_half
Renders Full Home	10.10.11.1:/mnt/md0/renderers
Renders Half Home	10.10.11.1:/mnt/md0/renderers_half

# Using Incinerator for Real-Time Playback

To use Incinerator for real-time playback, you must connect to a group (cluster) of Incinerator Nodes from Lustre and then enable real-time playback. If you have not already created a cluster of nodes, see [Managing Node Groups](#) on page 52.

See the following table for the tasks you must complete to use Incinerator for real-time playback in Lustre.

Step:	Refer to:
1. Open the Cluster menu.	<a href="#">Accessing the Cluster Menu</a> on page 79.
2. Connect to a group of Incinerator Nodes.	<a href="#">Connecting to Incinerator Node Groups</a> on page 79.
3. Enable real-time playback with Incinerator.	<a href="#">Enabling Real-Time Playback with Incinerator</a> on page 80.
4. Add grades and effects, and play back your shots.	Autodesk Lustre Help

## Accessing the Cluster Menu

To connect to a group of Incinerator Nodes, you must access the Cluster menu in Lustre.

To access the Cluster menu:

- In the Main menu, click Render.  
The Cluster menu appears.

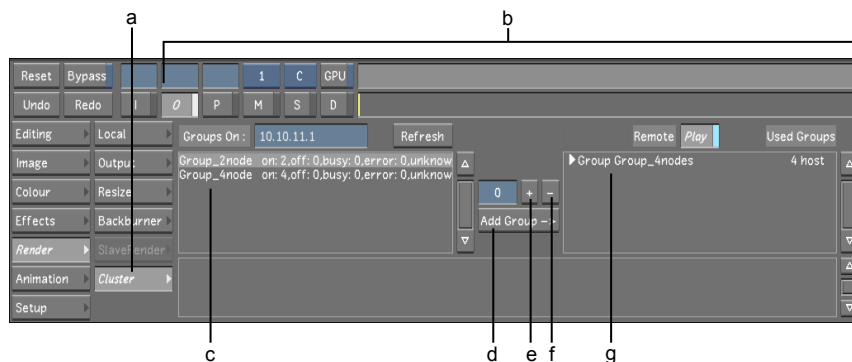

(a) Cluster button (b) Cluster menu (c) List of Incinerator Node groups (d) Add (Remove) Group button (e) Add Incinerator Node button (f) Remove Incinerator Node button (g) List of Incinerator Node groups loaded in project

## Connecting to Incinerator Node Groups

To use Incinerator for real-time playback, you must connect to a group of Incinerator Nodes from the Cluster menu.

Before you can load Incinerator Node groups in the Lustre application, you must create them in the Incinerator Resource Manager. See [Creating Incinerator Node Groups](#) on page 53 for information about creating Incinerator Node groups.

To start Lustre and Incinerator on the workstation:

- 1 In the main menu, click Render, and then click Cluster.  
The Cluster menu appears.
- 2 From the list of Incinerator Node groups, select a group of nodes to use for this project.

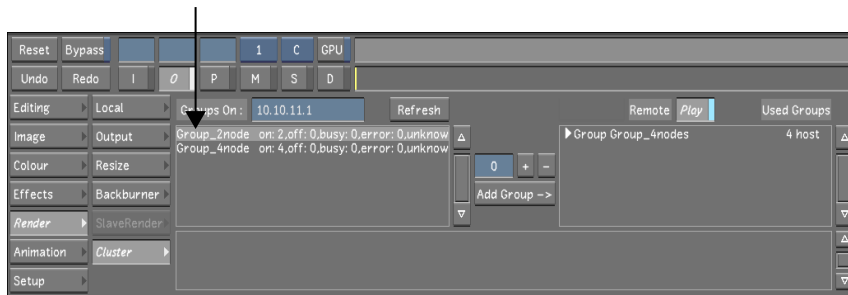

By default, all nodes in the group are available to the project.

**NOTE** If you create additional groups using the Incinerator Resource Manager while Lustre is open, you must click Refresh for those groups to appear in the list and be available for use.

- 3 Optional: Select the number of nodes in the group that you want to use by clicking the Add Incinerator Node button. You can also type a number in the field to the left of the Add Incinerator Node button. You can remove nodes by clicking the Remove Node button.
- 4 Click Add Group.  
This moves the selected group to the list of groups loaded in the project to the right.
- 5 From the list of Incinerator Node groups loaded in the project, select the Incinerator Node group to be used during the session and click Reconnect.

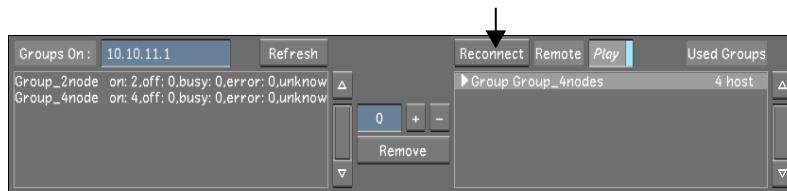

The Lustre application connects to and takes control of the Incinerator Nodes in the group. When you restart the application, Lustre reconnects to the group of Incinerator Nodes you last used.

### Enabling Real-Time Playback with Incinerator

To play back frames in real-time using Incinerator, you must enable the Play button. The Play button is enabled by default.

**To enable real-time playback with Incinerator:**

- 1 In the main menu, click Render, and then click Cluster.  
The Cluster menu appears.
- 2 Click the Play button to enable real-time play back of rendered frames using Incinerator.

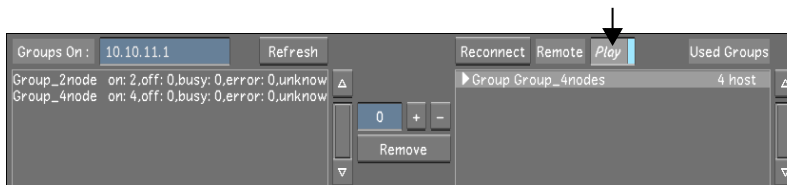

- 3 Begin using Lustre to create colour grades and effects.
- 4 Play back your shot. For instructions, see the Lustre help.

The Incinerator Nodes in the group process the grades and effects for real-time playback.



# Troubleshooting Tips

# 10

## Topics in this chapter:

- [Resolving Common Problems](#) on page 83
- [Stopping and Starting Incinerator Daemons Manually](#) on page 85
- [Viewing Incinerator Daemon Log Files](#) on page 86
- [Changing the IP Addressing Scheme](#) on page 86
- [InfiniBand Management](#) on page 88

## Resolving Common Problems

This section provides a list of common problems that you may encounter on an Incinerator system and suggestions for how to resolve them.

Problem	Common Cause
The Incinerator Lustre Media Server takes a long time to start up.	There are unconnected ports on the fibre-channel adapter. See <a href="#">Shortening Startup Time for the Incinerator Lustre Media Server</a> on page 83.
The monitor on the Lustre workstation flashes at startup, or the login screen does not appear.	The NVIDIA® driver or the <i>xorg.conf</i> file is incorrect. See <a href="#">Restoring the Workstation Graphics Driver and Monitor Settings</a> on page 84.
Playback is not real-time.	There are a number of possible causes for this problem. See <a href="#">Troubleshooting Problems with Real-Time Playback</a> on page 84.

## Shortening Startup Time for the Incinerator Lustre Media Server

If the Lustre Media Server takes a long time to start up, check the messages on the boot screen. If the messages indicate that the kernel is waiting for the fibre channel driver, make sure all ports on the fibre channel cards

are either connected to a storage device or have fibre-channel loops attached. The fibre channel driver may wait several minutes for each unconnected port before it times out.

## Restoring the Workstation Graphics Driver and Monitor Settings

Both the graphics driver and the *xorg.conf* file must be correct for the graphics to appear on a Lustre workstation.

---

**NOTE** The flashing NVIDIA logo or login screen problems can also be caused by bad connections on any device. Before you continue troubleshooting the graphics driver and monitor settings, ensure that all devices are properly connected. You can also check the */var/log/Xorg.0.log* file for device errors.

---

The easiest way to restore the graphics driver and *xorg.conf* file to the correct versions is to reinstall the DKU. Perform the following procedure to boot the system into text-only mode, and reinstall the DKU.

### To boot into text-only mode and reinstall the DKU:

- 1 Reboot the Lustre workstation and press **A** when the GRUB boot screen appears.

---

**NOTE** If a flashing NVIDIA logo prevents you from logging in to reboot the workstation, try logging in remotely as root from another workstation on the network and performing a reboot.

---

- 2 When the GRUB boot prompt appears, configure the workstation to boot in text-only mode by adding a **3** at the end of the kernel line and pressing **Enter**.

The workstation boots in text-only mode and you are prompted to log in.

- 3 Log in as root.

- 4 Create a backup of the current *xorg.conf* file. Type:

```
cp /etc/X11/xorg.conf /etc/X11/xorg.conf_backup
```

- 5 Reinstall the DKU. See the latest Release Notes for the correct DKU version. For installation instructions, see [Installing the DKU](#) on page 31.

- 6 Restart the Lustre workstation by typing:

```
init 5
```

## Troubleshooting Problems with Real-Time Playback

The most common sources of problems with real-time playback are out-of-sequence image files on the storage, multiple copies of the image sequence on the storage, storage bandwidth, video output issues, and complexity of clip setups. Use the following as a checklist to try to narrow down the source of your particular problem. If none of these appear to be the problem, or you are unsure how to resolve the problem, contact Customer Support.

- Make sure that the image sequence is written sequentially on the storage. If the sequence is not written sequentially, the time required to retrieve the individual frames may impact real-time performance. For example, if you have two folders with scans to transfer to storage, you must copy those folders one after the other. If you copy both folders at the same time or copy the second before the first copy is complete, the contents of the folders will not be written sequentially to the disks in the storage.
- If the clip is on a Storage Area Network (SAN), make sure the host machine has the bandwidth required for real-time playback.

- Make sure you can play back the cut file associated with the grade in real time when the Incinerator nodes are disconnected. Be sure to load only the cut, not the grade.
- Determine whether you can achieve real-time playback when you disable your DVS or NVIDIA video output.
- An Incinerator storage system should be able to sustain a minimum of a 2K clip stream (2048 x 1556 DPX 10-bits) when the Incinerator nodes are disconnected. First verify that the images can be played back in real time, without any colour correction applied and with the Incinerator nodes disconnected. If this is possible, try connecting the Incinerator nodes and loading a grade. If real-time playback of the grade is not possible, try disabling a selective, disabling effects, or cropping the image and observe any impact on performance.

## Stopping and Starting Incinerator Daemons Manually

Incinerator relies upon the following daemons to provide real-time playback to Lustre, and for Incinerator network management.

**BrowseD** Runs on the Lustre Media Server. It provides access to frames on its storage.

**cmanagerd** Runs on the Lustre Media Server. It collects status information from *renderd* and *BrowseD* and stores this information in a database that is used to populate the Incinerator Resource Manager.

**renderd** Runs on the Incinerator Nodes. It renders the frames with the grades and effects and sends them to the Lustre workstation for real-time playback.

Under most circumstances, you can start and stop *BrowseD* and *renderd* using the Incinerator Resource Manager. See [Stopping and Starting Incinerator Daemons](#) on page 64.

However, if you change configuration files, you must restart *BrowseD*, *renderd*, and *cmanagerd* manually. See the following table to determine when modifications to a configuration file require a manual restart of a daemon.

When You Change:	On Component:	Manually Restart Daemon:
<i>cmanagerdclient.conf</i>	Lustre Media Server	<i>BrowseD</i>
<i>cmanagerd.conf</i>	Lustre Media Server	<i>cmanagerd</i>
<i>cmanagerdclient.conf</i>	Incinerator Nodes	<i>renderd</i>

To restart Incinerator daemons manually:

- 1 Log in as root to the machine and open a shell.
- 2 Use the following table to select the command for the daemon you want to restart.

Component	Daemon	Command
Lustre Media Server	<i>BrowseD</i>	<code>/etc/init.d/browseD_2009.SP7 restart</code>
Lustre Media Server	<i>cmanagerd</i>	<code>/etc/init.d/cmanagerd_2009.SP7 restart</code>
Incinerator Node	<i>renderd</i>	<code>/etc/init.d/renderd_2009.SP7 restart</code>

# Viewing Incinerator Daemon Log Files

Many events in Incinerator are recorded in log files. A good troubleshooting strategy is to view the last few event(s) recorded in the log files before the problem occurred. These files can help you recreate the series of events leading up to the problem and may indicate or identify its cause. You may also be requested by Customer Support to send copies of your log files to help them troubleshoot the problem.

You can view log files for the following Incinerator-related daemons:

- *BrowseD* on the Lustre Media Server.
- *renderd* on the Incinerator Nodes.
- *cmanagerd* on the Lustre Media Server.

Use the following procedure to view the log files for either daemon.

## To view Incinerator log files:

- 1 Log in as root to the Lustre Media Server, Lustre workstation, or Incinerator Node.
- 2 Navigate to the directory containing the log files (*/var/log*) by typing:  
**cd /var/log**
- 3 Type one of the following commands to display the Incinerator-related log file in this directory.

For:	Type:
<i>BrowseD</i>	<b>ls   grep -i browsed</b>
<i>cmanagerd</i>	<b>ls   grep -i cmanagerd</b>
<i>renderd</i>	<b>ls   grep -i renderd</b>

The appropriate log file appears in the output. If no log file appears, the daemon may not be started on the Lustre Media Server or Incinerator Node.

- 4 Do one of the following to view the contents of the log file:
  - Use the `tail` command to view the last few lines of the log file.
  - Use the `more` command to view the log file in its entirety.
  - Copy the log file to another workstation on the network and open it in a text editor.

# Changing the IP Addressing Scheme

The Incinerator system comes shipped with the following default IP addressing scheme.

Component	GigE IP Address	GigE Subnet Mask	InfiniBand IP Address	InfiniBand Subnet Mask
Lustre Media Server	10.10.10.x	255.255.255.0	10.10.11.x	255.255.255.0
Nodes	10.10.10.10x	255.255.255.0	10.10.11.10x	255.255.255.0
Workstation	10.10.10.20x	255.255.255.0	10.10.11.20x	255.255.255.0

If you decide to change the IP addressing scheme of the Incinerator system after you receive it, there are a number of configuration files that must be changed and daemons that must be restarted.

The following procedure outlines the workflow you should follow when changing the IP addressing scheme of your Incinerator system.

**To change the IP addressing scheme:**

- 1 Update the network configuration on all components. Do the nodes, workstation, and then the Lustre Media Server.

The following configuration files must be updated on all components:

- `/etc/hosts`
- `/etc/sysconfig/network-scripts/ifcfg-<host adapter>`

After you make all of these changes on a machine, reboot the machine and continue to the next machine.

After you have updated the network configuration on all machines, use **ping** to test communication between all components on both the InfiniBand and GigE networks before you continue.

- 2 After you have changed the network settings on all the components, start working on the Lustre Media Server to update the configuration files and to restart services.

Update `cmanagerdclient.conf` with the latest IP address of the Lustre Media Server. See [cmanagerdclient.conf](#) on page 77.

Then, manually restart the license server. In a shell, type:

```
/etc/init.d/license_server restart
```

Next, restart `cmanagerd` and `BrowseD` manually. See [Stopping and Starting Incinerator Daemons Manually](#) on page 85.

Finally, check the Incinerator Resource Manager in a Web browser. The Manager status should appear as “online” and the Lustre Media Server should appear on the Servers tab with the status “ready”. See [Using the Incinerator Resource Manager](#) on page 49.

- 3 After the Lustre Media Server is updated, move to the nodes to update the configuration files and restart the daemons.

Update `/usr/autodesk/lustre<application_version>/cmanagerdclient.conf` with the latest IP address of the Lustre Media Server.

Next, restart the `renderd` daemon manually.

Finally, check the Incinerator Resource Manager in a Web browser. The Incinerator Nodes should appear on the Groups and Nodes tabs with the status “ready”.

- 4 On the workstation, update the `cmanagerdclient.conf` and `browsed.config` files with the latest IP address of the Lustre Media Server. For information on `BrowseD`, see [init.config](#) on page 76.

When you are done with the updates restart Lustre and check the Incinerator Resource Manager in a Web browser. The workstation should appear on the Workstation tab with the status “ready”.

- 5 If you have any projects that were created before you changed the IP addressing scheme, you must update the project paths to point to the GigE address of the Lustre Media Server. In addition, if you had previously connected to Incinerator Node Groups from the Render!Cluster menu in Lustre, you must remove the old groups and reconnect to the new ones to enable real-time playback with Incinerator. See [Using Lustre with Incinerator](#) on page 78.

---

**NOTE** If any of the components were connected to the Incinerator Resource Manager before you changed your IP addressing scheme, you will have duplicate entries in the Resource Manager. To delete duplicate entries in the Resource Manager, see [Deleting Duplicate Entries](#) on page 66.

---

# InfiniBand Management

There are two noteworthy InfiniBand network management and logging facilities. The following two sections describe these facilities.

For more information about configuring, monitoring, and managing the InfiniBand switch and network, see the documentation provided by the manufacturer of the switch.

## Reviewing Port Statistics Using the InfiniView Web Monitor

The InfiniBand switch comes with a Web-based application, the InfiniView Device Manager™, that you can use to configure, monitor, and manage the InfiniBand network. To access the Device Manager, your browser must be on the same subnet as the InfiniBand switch, which has a default IP address of 10.10.10.252.

The following illustration shows the main page of the Device Manager.



If you click the Port Stats link on the main page, the IB Port Statistics page opens.

Port Name	Port #	Link State	Physical State	Link Down Default	Active Link Width	Link Width Enabled	Link Width Supported	Active Link Speed	Link Speed Enabled	Link Speed Supported	Transmit 32Bit Words	Receive 32Bit Words	Transmit Packets	Receive Packets	Transmit Wait	Symbol Errors
Cable 1	1.1	active	Up	Poling	4X	4X	1X or 4X	2.5Gb/s	2.5Gb/s	2.5Gb/s	754212507	748212468	2881936	2659139	0	0
Cable 2	1.2	active	Up	Poling	4X	4X	1X or 4X	2.5Gb/s	2.5Gb/s	2.5Gb/s	751891896	745623576	2873068	2849248	0	0
Cable 3	1.3	active	Up	Poling	4X	4X	1X or 4X	2.5Gb/s	2.5Gb/s	2.5Gb/s	744929991	737856756	2846463	2819573	0	0
Cable 4	1.4	active	Up	Poling	4X	4X	1X or 4X	2.5Gb/s	2.5Gb/s	2.5Gb/s	744929991	737856756	2846463	2819573	0	0
Cable 5	1.5	active	Up	Poling	4X	4X	1X or 4X	2.5Gb/s	2.5Gb/s	2.5Gb/s	742809987	735268126	2837596	2809683	0	0
Cable 6	1.6	active	Up	Poling	4X	4X	1X or 4X	2.5Gb/s	2.5Gb/s	2.5Gb/s	740288841	732679116	2828728	2799793	0	0
Cable 7	1.7	active	Up	Poling	4X	4X	1X or 4X	2.5Gb/s	2.5Gb/s	2.5Gb/s	740288841	732679116	2828728	2799793	0	0
Cable 8	1.8	active	Up	Poling	4X	4X	1X or 4X	2.5Gb/s	2.5Gb/s	2.5Gb/s	735647547	727501189	2810991	2780009	0	0
Cable 9	1.9	active	Up	Poling	4X	4X	1X or 4X	2.5Gb/s	2.5Gb/s	2.5Gb/s	196259	4294967295	25892	22727341	0	0
Cable 10	1.10	active	Up	Poling	4X	4X	1X or 4X	2.5Gb/s	2.5Gb/s	2.5Gb/s	4294967295	195429	22509150	25337	0	0
Cable 11	1.11	down	Poling	Poling	4X	1X or 4X	1X or 4X	2.5Gb/s	2.5Gb/s	2.5Gb/s	0	0	0	0	0	0
Cable 12	1.12	down	Poling	Poling	4X	1X or 4X	1X or 4X	2.5Gb/s	2.5Gb/s	2.5Gb/s	0	0	0	0	0	0
Cable 13	1.13	down	Poling	Poling	4X	1X or 4X	1X or 4X	2.5Gb/s	2.5Gb/s	2.5Gb/s	0	0	0	0	0	0

In the IB Port Statistics page, you can check the status of each port on the switch. To update the data that displays on the page, be sure to click the Refresh button.

## Reviewing Statistics and Information for a Port

There are two commands packaged with the InfiniBand driver that provide statistics and information about a port. The information provided by these commands is similar to that displayed in the InfiniView Device Manager.

To review statistics and information about a port:

- 1 Log in to the machine as root.
- 2 Type the following commands in a shell:  

```
cat /proc/iba/mt23108/1/port<x>/stats  
cat /proc/iba/mt23108/1/port<x>/info
```

where <x> is the port number on the device.  
A report appears in the shell.

## Generating InfiniBand Log Files for Support

The script `/sbin/iba_capture` gathers information about your system and InfiniBand configurations that can be useful for troubleshooting InfiniBand issues. This script outputs a GZIP file.

To run the InfiniBand log file capture script:

- As root, open a shell and type:  

```
/sbin/iba_capture <path and name of output gzip file>
```

A GZIP file is generated that includes a number of log files from your system.

---

**NOTE** The help for this command indicates that the output is a TAR file, when it is in fact a GZIP file.

---



# Configuring Background Rendering



## Topics in this chapter:

- [About Background Rendering](#) on page 91
- [Background Rendering Components](#) on page 92
- [Workflow for Setting Up Background Rendering](#) on page 93
- [Sharing the Storage for Read/Write Access from Background Render Nodes](#) on page 93
- [Installing Backburner Manager and Backburner Web Monitor](#) on page 94
- [Configuring Lustre to Detect Backburner Manager](#) on page 95
- [Setting Up Render Nodes](#) on page 95
- [Specifying the Background Rendering Path in Lustre](#) on page 101

## About Background Rendering

During background rendering, a shot on the timeline is rendered by a background rendering network. This is different from the Slave Renderer, which renders shots on a shot-by-shot basis as they are colour graded to enable playback performance.

Background rendering in Lustre is performed using Burn™ for Lustre, also known as the Lustre Background Renderer. This application is specific to Lustre and provides asynchronous background processing of Lustre render jobs. By off-loading rendering activities to remote Linux® servers, Lustre stations are freed up for interactive colour grading, while background rendering is sped up by splitting the task among multiple hosts.

# Background Rendering Components

The components of the basic background rendering package include Lustre, a background management and monitoring application (such as Backburner Web Monitor, or the Backburner Monitor in WiretapCentral), and several render nodes running on Linux servers. The Incinerator system and all background rendering nodes are connected through NFS mount points over a dedicated background TCP/IP network.

The background rendering components are illustrated as follows.

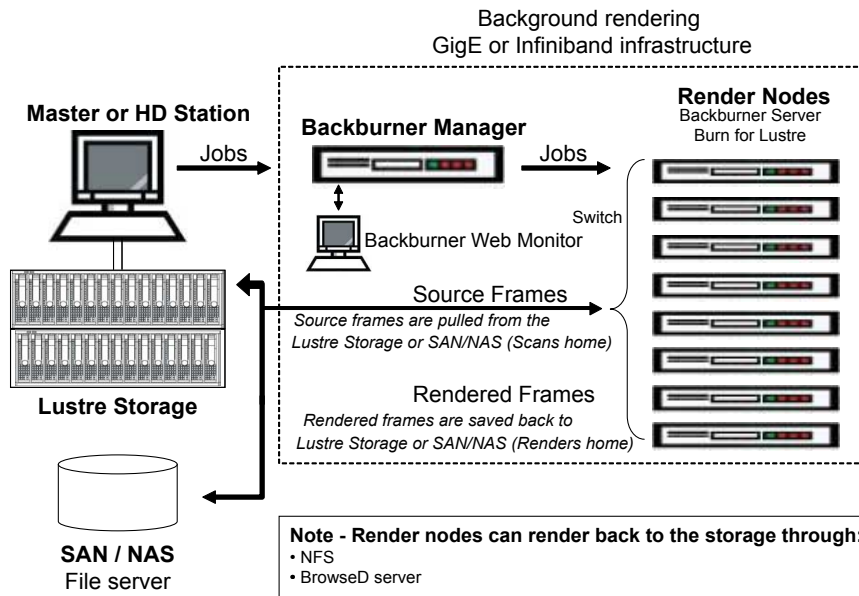

---

**NOTE** You can have up to eight render nodes on the background rendering network.

---

For faster access to remote locations for footage and metadata, BrowseD can be used instead of NFS or SMBFS mount points. BrowseD is covered in detail in *Configuring BrowseD*. The other background rendering components are described as follows.

**Lustre application** This is the client application. Running on a Linux workstation, Lustre rendering jobs are submitted for background rendering through the Render | Backburner menu.

**Backburner Manager** This is the hub of the background rendering workgroup. Backburner Manager resides on the Lustre Media Server machine. When jobs are submitted from Lustre to Backburner Manager, Backburner Manager breaks each submitted job into tasks and distributes the tasks to the rendering servers on the network. To view the progress of the tasks, use Backburner Web Monitor.

**Backburner Web Monitor** This is the user interface for the Backburner rendering network. It allows you to view and control jobs currently being processed. You can stop, restart, reorder or remove jobs completely using the Monitor. You also use Backburner Web Monitor to identify any render nodes that are not working and check the overall status of the rendering network.

Backburner Web Monitor can be accessed through a Web browser from any workstation on the network.

**Backburner Server** This is a server that runs on render nodes. Backburner Server accepts commands from Backburner Manager to start and stop rendering tasks. Backburner Server communicates through a plug-in to execute rendering tasks.

---

**NOTE** Consult the latest *Autodesk Backburner Installation Guide* and *Autodesk Backburner User Guide* for detailed information on Backburner. Use the guides to obtain Backburner information that does not relate directly to Lustre background rendering, such as details on setting up Web monitoring and troubleshooting tips.

---

**Burn for Lustre** This is the Linux rendering engine that renders one or more frames from Lustre render jobs.

**Shared storage mount point** This is the mount point on each Linux server that allows Burn for Lustre to transfer rendered frames/files to the Lustre storage system.

---

**NOTE** The storage does not have to be mounted on the render nodes if you are using BrowseD for background rendering. See the latest *Autodesk Lustre Installation and Configuration Guide* for details about setting up *BrowseD*.

---

## Workflow for Setting Up Background Rendering

Use the following workflow to set up background rendering in an Incinerator configuration. You can use this workflow either to configure inline render nodes to also serve as background render nodes, or to add dedicated background render nodes to your Incinerator configuration.

You can set up as many as eight render nodes for background rendering with Incinerator.

---

**NOTE** This workflow assumes that Linux is already installed on the node. If this is not the case, refer to [Linux Installation Workflow](#) on page 29 for help on installing Linux. If you must install Linux from scratch on an inline rendering node, be sure the inline rendering software is installed prior to setting up the node to also perform background rendering. Refer to [Installing the Incinerator Node Software](#) on page 47.

---

The following table outlines the general workflow for installing and configuring background rendering.

Step:	Refer to:
1. Enable sharing on the system storing the Lustre project and render files.	<a href="#">Sharing the Storage for Read/Write Access from Background Render Nodes</a> on page 93.
2. Install and configure Backburner Manager and Backburner Web Monitor.	<a href="#">Installing Backburner Manager and Backburner Web Monitor</a> on page 94.
3. Configure the Lustre workstation to connect to Backburner Manager so that it can send background render requests to Backburner Manager.	<a href="#">Configuring Lustre to Detect Backburner Manager</a> on page 95.
4. Set up the background rendering components of the nodes.	<a href="#">Setting Up Render Nodes</a> on page 95.
5. Specify the mount point of the background rendering nodes in the Lustre application.	<a href="#">Specifying the Background Rendering Path in Lustre</a> on page 101.

## Sharing the Storage for Read/Write Access from Background Render Nodes

In order to allow read and write access, the storage must be exported from the system to which it is connected. This makes it possible for the background rendering components on the network to remotely mount the storage system.

**To make the storage system visible over the network:**

- 1 Login to the Lustre Media Server as *root*. The storage filesystem is mounted as */mnt/md0*.
- 2 Open the */etc/exports* file in a text editor, such as *vi*.  
The contents of the *exports* file appears, listing the available network shares (filesystems mountable over the network).
- 3 At the end of the file, add a new line for the mount point of the storage filesystem:

```
/mnt/md0 *(rw,no_subtree_check,async)
```

This line creates a network share for the mount point of the storage filesystem. Other users on the network will access the storage devices by mounting its network share.

4 Save and close the file.

5 Activate the new network share for the storage device. Type:

```
exportfs -a
```

The list of network shares is refreshed from the *exports* file.

6 Verify the storage devices are available to be mounted by typing:

```
exportfs
```

Make sure the storage filesystem mount points are listed in the command output.

## Installing Backburner Manager and Backburner Web Monitor

It is recommended that you install Backburner Manager and Backburner Web Monitor on the Lustre Media Server.

**To install Backburner Manager and Backburner Web Monitor on a Linux system:**

1 Open a terminal and log in as root.

2 Access the Autodesk Lustre software installation package (from a downloaded *tar* file or on CD).

3 Install Backburner by typing:

```
rpm -Uvh backburner*
```

The Backburner components (Server, Manager and Web Monitor) are installed on the system.

4 During the installation process, you are asked if you want to automatically run Backburner Manager and Backburner Server on the machine. Answer Yes to the question about the Manager, and No to the question about the Server.

5 Run the Backburner Web Monitor configuration script:

```
/usr/discreet/backburner/backburnerConfigWeb
```

The script automatically configures Backburner Web Monitor.

**To verify that Backburner components are running properly:**

1 On the system on which you installed Backburner Manager, as root, type:

```
ps -ef | grep -i backburner
```

The output of the command should include a line containing the path to the Backburner Manager application, similar to the following:

```
root 14989 10 Nov29 ? 00:02:36  
/usr/discreet/backburner/backburnerManager
```

---

**NOTE** If Backburner Manager is not running, the Backburner log file */usr/discreet/backburner/Network/backburner.log* may be a useful source of information for troubleshooting.

---

2 To test that Backburner Web Monitor is installed and configured properly, open a Web browser on the Manager machine and point it to *http://localhost/backburner*.

Backburner Web Monitor opens. If you are asked for a user name and password, use *backburner* for both.

Refer to the *Autodesk Backburner Installation Guide* for detailed information on configuring Backburner.

## Configuring Lustre to Detect Backburner Manager

For Backburner Manager to receive render jobs, you must set up the Lustre application to connect to the system on which Backburner Manager is running.

To configure new projects to use background rendering, you must set the IP address of the Backburner Manager workstation in the *init.config* file. This value will be copied to the configuration of all subsequently created projects.

If you installed Backburner Manager on the Lustre Media Server, use the IP address of the Lustre Media Server.

### To configure the Lustre application to detect Backburner Manager:

- 1 Locate the `Backburner` keyword.
- 2 In the `HostName` line, set the `string` parameter to the IP address of the system where Backburner Manager is installed (in the recommended configuration, this is the Lustre Media Server).. For example:

```
<HostName string="172.19.23.161" />
```

---

**NOTE** Do not forget the quotes.

---

- 3 Save and close the configuration file.

For more information on the configuration file keywords, see *Software, Project, and User Configuration Files*.

## Setting Up Render Nodes

If you are setting up background rendering on an Incinerator node (so that it can serve for both inline and background rendering), you can skip this section. Burn for Lustre was installed when you installed the Incinerator node software.

If you are setting up dedicated background render nodes, you must install Burn for Lustre on each of those nodes.

You can set up as many as eight render nodes for background rendering with Lustre. On each system intended for background rendering, you must do the following.

Step:	Refer to:
1. Verify that the render nodes meet the minimum system requirements.	<a href="#">Render Node Hardware and Software Requirements</a> on page 96.
2. Install the appropriate Red Hat operating system.	<a href="#">Installing Linux on Render Nodes</a> on page 96
3. Configure each node to mount the storage that contains the project render files.	<a href="#">Mounting the Storage on the Render Nodes</a> on page 97.
4. Install Burn for Lustre.	<a href="#">Installing Burn for Lustre</a> on page 98.
5. Connect the render nodes to Backburner Manager.	<a href="#">Configuring Backburner Server to Detect Backburner Manager</a> on page 99.

---

**Step:****Refer to:**

6. Start the Backburner Server on each render node.

[Starting Backburner Server](#) on page 99.

---

## Render Node Hardware and Software Requirements

Render nodes purchased from Autodesk come with all the necessary hardware and software components preinstalled.

To use Burn for Incinerator on nodes that were not purchased from Autodesk, the nodes must meet the minimum hardware and OS requirements listed in the following table.

---

Processor:	1 or 2 Xeon® Intel® Processor DP
Memory:	2 GB
Hard drive:	20 GB
Ethernet:	100/1000 Mbps
OS:	Red Hat Enterprise Linux 5.3 with Workstation option, customized with the Autodesk kickstart file.

---

## Installing Linux on Render Nodes

Autodesk Burn for Lustre runs under the custom 64-bit Autodesk distribution of Red Hat Enterprise Linux.

Render nodes purchased from Autodesk ship with the correct Autodesk distribution of Red Hat Enterprise Linux on DVD.

If you did not purchase your render node from Autodesk, you must get your own 64-bit distribution of Red Hat Enterprise Linux Desktop 5.3 with Workstation option, and customize it using the Autodesk kickstart file.

The kickstart is used to automatically install the packages required for Burn, some of which are not installed as part of a general installation.

This file is available in Lustre installation directory. You must copy it to the DVD of your Linux distribution.

---

**TIP** The kickstart file can be used to automate the Linux installation process for multiple render nodes.

---

### To copy the Autodesk kickstart file to the DVD of your Linux distribution:

- 1 On a computer running Linux and with a DVD burner, log in as root.
- 2 Insert the DVD of your Linux distribution into the drive. You do not need to mount it at this time.
- 3 In a terminal, extract an ISO image of the disc by typing:  

```
dd if=/dev/<optical_disc_device> of=/<destination path for the extracted ISO image>
```

For example:  

```
dd if=/dev/cdrom of=/tmp/RHEL5.3.iso
```

Depending on the speed of your disc drive, this command may take several minutes to complete.
- 4 Eject the disc.
- 5 Access the *dist* subdirectory of the Lustre installation package.

The directory contains a kickstart file, `ks_centos5_rh5.cfg`, as well as a script that adds the kickstart file to an ISO image.

- 6 Run the `build_kickstart_cd` script to add the kickstart file to the ISO image of your Linux distribution DVD:

```
./build_kickstart_cd ks_centos5_rh5.cfg <original ISO image name> <new ISO image name>
```

For example, if the ISO image you created is called `/tmp/RHEL5.3.iso` and you want the new ISO image to be called `/tmp/RHEL5.3_KS.iso`, type:

```
./build_kickstart_cd ks_centos5_rh5.cfg /tmp/RHEL5.3.iso  
/tmp/RHEL5.3_KS.iso
```

- 7 Once the new ISO image of the Linux distribution DVD is created, burn it to a blank disc using a tool such as `cdrecord`.

---

**NOTE** Type `man cdrecord` for information about this utility.

---

The new disc that you burn contains the Autodesk kickstart file and replaces the DVD in the Linux distribution.

You are now ready to install Linux on the render node. See [Linux Installation Workflow](#) on page 29 for instructions on installing Linux.

## Mounting the Storage on the Render Nodes

After Red Hat Linux is installed, you must mount the media storage on each render node using an NFS mount point. This involves identifying the IP address of the system that manages the storage (for example the Lustre Media Server) and setting a mount point on each render node that points to the correct path on the storage. Also, for this mount point to be available when you restart the system, you must add an entry in the `fstab` file.

If the system that stores the render files is different from the system that stores the Project Home directories, you need two (or more) mount points. For example, if, in the Project Setup menu, the Project Home path is `/mnt/md0/SCENES` and the Renders Full Home path is `Sanserver:/RENDERS` located on a central storage system, you must define a mount point for each path.

The `BrowseD` service can also be used to allow background render nodes to access the workstation's storage. `BrowseD` allows for fast access and requires a separate license. If you are using `BrowseD` for background rendering, you do not have to mount the storage on the render nodes. See the latest *Autodesk Lustre Installation and Configuration Guide* for details.

### To mount the storage on a render node:

- 1 Determine the IP address of the computer that manages the storage.  
If you are using direct attached storage only, this is the IP address of the Lustre Media Server. You must also determine the IP address of your centralized file server if you are also using a server area network (SAN) or network attached storage (NAS).
- 2 On the render node, log in as `root`.
- 3 Go to the root directory. In a terminal, type:  
`cd /`
- 4 Create a directory for the mount point. For example, type:  
`mkdir /mnt/md0`

---

**NOTE** The directory name must be the same for the mount point on each node. Also, the directory should not be created in the `/root` directory, but in the `/mnt` directory.

---

- 5 Change the permissions on this folder to allow read/write access. For example, type:  

```
chmod 666 /mnt/md0
```
- 6 Set up the mount point to access the Lustre system storage or the central system storage. You must use the mount point as defined in the `Project_home` setting in the Lustre Project Setup menu. For example, if the Project Home is `/mnt/md0/SCENES`, and the Linux mount point directory is named `/mnt/md0`, the mount command will be:  

```
mount <hostname>:/mnt/md0/SCENES /mnt/md0
```

To add an entry in the `fstab` file:

- 1 Open the file `/etc/fstab` in a text editor and then add a line for your new mount point:  

```
<IP address>:/<exported filesystem> /<mount point> nfs  
rw,bg,hard,intr,nfsvers=3 0 0
```

For example, type:  

```
172.16.60.226:/mnt/md0 /mnt/md0 nfs rw,bg,hard,intr,nfsvers=3 0 0
```

---

**NOTE** The example is a single line.

---

- 2 Save and close the file.  
The file is saved and you are returned to the command prompt.
- 3 Restart the render node.  
When you restart your system, this remote location will mount automatically.

## Installing and Configuring Burn for Lustre

Install and configure Burn for Lustre on each render node. To install and configure Burn for Lustre, you must:

- Install Burn for Lustre.
- Add the IP address of the machine where Backburner Manager is installed (the recommended location is the Lustre Media Server) to the `manager.host` file on each render node.
- Start the Backburner Server on each render node.
- License Burn for Lustre.

### Installing Burn for Lustre

Perform the following procedure to install the Burn for Lustre software on each node.

---

**NOTE** When you install Burn for Lustre, the necessary Backburner components are also installed on the render node.

---

To install Burn for Lustre:

- 1 Open a terminal and log in as `root`.
- 2 Access your Autodesk Lustre installation package (from a downloaded `tar` file or on CD).

- 3 Start the Burn installation script by typing:

```
./INSTALL_LUSTRE_<application_version>_BURN
```

The Burn for Lustre package is installed. For instructions on obtaining and installing a Burn license, see [Licensing Burn for Lustre](#) on page 100.

- 4 Repeat this procedure on all render nodes.

### Configuring Backburner Server to Detect Backburner Manager

Backburner Server needs to be able to detect the location of Backburner Manager in order to provide status information concerning the render jobs. Set the IP address of the Backburner Manager machine in the `/usr/discreet/backburner/cfg/manager.host` configuration file on each render node.

---

**NOTE** You can also use the hostname of the Backburner Manager machine, if it has been properly defined in the `/etc/hosts` file.

---

#### To configure Backburner Server to detect Backburner Manager:

- 1 On the Backburner Manager system, open a terminal and log in as root.
- 2 Determine which IP address the Backburner Manager workstation uses to connect to the network. Type:  
**ifconfig**  
Information about all the network adapters is displayed. The second line of the output for each adapter contains the IP address (listed as “inet addr”). For example:  

```
inet addr:172.16.129.152 Bcast:172.16.135.255 Mask:255.255.248.0
```

Write down the IP address of the network adapter. If the machine has several network adapters, make sure you write down the address of the one connected to your render network.
- 3 On each render node, open a terminal and log in as *root*.
- 4 Type:  
**cd /usr/discreet/backburner/cfg**
- 5 Use a text editor to edit the `manager.host` file.
- 6 Enter the IP address of the Backburner Manager machine. For example:  
**10.10.10.1**
- 7 Save and close the file.  
The file is saved and you are returned to the command prompt.

### Starting Backburner Server

You must start the Backburner Server daemon on each Linux system for the first time. Once it is started the first time, the daemon will start automatically.

#### To start Backburner Server:

- 1 Log in to your Linux system as *root*.
- 2 In a terminal, type:  
**service backburner\_server start**
- 3 You can verify that Backburner Server is properly configured by checking the log file `usr/discreet/backburner/Network/backburnerServer.log`. Type:  
**tail -f /usr/discreet/backburner/Network/backburnerServer.log**

The file should contain lines similar to the following:

```
<INF>: Loading plugin: Lustre renderer plugin
```

- 4 To stop viewing the file, press **Ctrl+C**.
- 5 Repeat these steps to start Backburner Server on each node in the background rendering network.  
If you cannot start the Backburner Server, contact Autodesk Customer Support.

---

**NOTE** If you need to stop or restart Backburner Server, use one of these commands:

```
/etc/init.d/backburner_server stop
```

```
/etc/init.d/backburner_server restart
```

---

### Licensing Burn for Lustre

You need a license for your render nodes. Burn uses a floating license scheme, which means that licenses are centralized on a license server.

The license server automatically provides a license to all registered machines.

The license server runs on the Lustre Media Server. You install a single network license for background rendering in the server license file on the Lustre Media Server. You then create a license file on each of the nodes that points to the license server running on the Lustre Media Server. Each node contacts the license server to obtain its license.

To obtain a license code for background rendering, contact the Licensing Department with the *lmhostid* and host name of the Lustre Media Server.

#### To obtain the network license:

- 1 Open a terminal on the Lustre Media Server and run the *lmhostid* utility to obtain the unique host ID of the machine. Type:  
**lmhostid**  
A message appears that includes a line indicating the *lmhostid* of the machine. For example:  
The FLEXlm host ID of this machine is "<lmhostid>"
- 2 Write down the *lmhostid*.
- 3 Request license codes for background rendering from the Autodesk Media and Entertainment Licensing Department. See [Requesting Incinerator License Codes](#) on page 73.

#### To add the license to the license server:

- 1 Log in to the Lustre Media Server as root.
- 2 Go to the *licenses* directory by typing:  
**cd /usr/discreet/licserv/licenses/**
- 3 In a text editor such as *vi*, create a file called *DL\_license.dat* by typing:  
**vi DL\_license.dat**
- 4 In this file, enter all the information submitted to you by the Licensing Department upon your registration.
- 5 Save and close the file.
- 6 Start the license server by running the following command:

```
/etc/init.d/license_server start
```

---

**NOTE** The license server starts/stops automatically when the machine is booted/shut down. You can stop and restart the server manually by running one of the following commands:

```
/etc/init.d/license_server stop
```

```
/etc/init.d/license_server start
```

---

To enable the render nodes to contact the license server:

- 1 Log in to each render node as root.
- 2 Navigate to the license directory. Type:  

```
cd /usr/local/flexlm/licenses/
```
- 3 Open the *DL\_license.dat* file in a Linux text editor such as *vi*.
- 4 In this file, copy the first three lines of the information submitted to you by the Autodesk Licensing Department upon your registration. For example:  

```
SERVER burn-01 00255c720ce  
VENDOR lustre  
USE_SERVER
```
- 5 Save and close the file.

---

**NOTE** Each render node must be able to contact the license server. Use *ping* from each node to the license server to confirm that the machines can communicate.

---

## Specifying the Background Rendering Path in Lustre

The last step in setting up background rendering is to specify the correct mount points in the settings of each project that uses background rendering.

To add the storage path in Lustre:

- 1 Start Lustre.
- 2 In the Setup menu, click Settings.
- 3 Select your project in the Project drop-down list, and click Edit.  
The Project Settings menu appears.
- 4 Click Network Rendering, then click Backburner in the Configuration section.
- 5 Type the location of the Project Home, Scans Full Home, Scans Half Home, Renders Full Home and Renders Half Home as seen from the Linux render nodes. You only need to enter those locations that are defined for the project in the local project setup, located in the Setup | Project menu.  
The path required in these fields is comprised of the directory defined for the mount point and the actual storage folder. For example, if the Project Home is */mnt/md0/SCENES* in the Project Setup menu, and the Linux mount point directory is named *Lustre\_storage*, the Project Home path to enter in this menu is:  

```
/mnt/Lustre_storage/SCENES
```
- 6 Press **Enter**.

- 7 To verify that you have entered the proper path for each project, look at the project configuration file in `/usr/autodesk/lustre<application_version>/project/<project name>/project.config`. The value in the `burn_project_home` line is sent to the render node. This value must match a mount point on the background render nodes.

For help setting up and managing projects, refer to the Lustre Help.

# Software, Project, and User Configuration Files

# B

## Topics in this chapter:

- [Configuration File Overview](#) on page 103
- [System Settings](#) on page 104

## Configuration File Overview

The configuration files define all the necessary settings Incinerator needs to recognize various hardware and software settings on the Master Station or Incinerator HD Station, and on the dedicated render station.

Before doing any colour correction in Incinerator, you must first log into a project with a valid user profile. See the “Project Management” chapter in the *Autodesk Lustre User Guide*. When you create a user profile and project in Incinerator, you are indirectly creating the *user.config*, *project.config*, and *<user>Context.config* files. However, aside from the initial system configuration in the *init.config* file that you must set before you begin working, there is no need for you to manually create or modify any of the other configuration files. All of the configuration settings are set within Incinerator's user interface (refer to “System Settings” in the “Project Management” chapter of the *Lustre User Guide*).

When you log into a particular project in Incinerator for the first time, Incinerator creates the *<user>Context.config* file, where *<user>* represents the user name associated with the user profile. The context file is found in the *.../projects/<project>/* directory. The context keywords include some attributes not defined in the Project or User configuration settings. They are saved and reloaded each time the context (same user and project) applies. The context settings include:

- Last scene
- Last shot
- Resolution

- Crop value
- Assemble frame rate / drop frame mode
- State of the surface control
- Audio file

The following is a list of the Lustre configuration files.

Configuration file	Default Location	Description
<i>init.config</i>	<i>/usr/autodesk/lustre2009/</i>	This file stores system settings as well as Wiretap servers, Slave Renderer settings, and film stock information.
<i>login.config</i>	<i>/usr/autodesk/lustre2009/</i>	This file records the last user and last project used so at the next session, the user and project login defaults will reflect these values.
<i>project.config</i>	<i>/usr/autodesk/projects/&lt;project&gt;/project.config</i>	This file stores project-level information including project settings, calibration, rendering, engineering, and BackBurner and Wiretap settings specific to the project.
<i>user.config</i>	<i>/usr/autodesk/users/&lt;user&gt;/user.config</i>	This file stores user settings specific to a particular user, such as Autosave, printer light, GUI background/gain/gamma.
<i>&lt;user&gt;Context.config</i>	<i>/usr/autodesk/projects/&lt;project&gt;/&lt;user&gt;Context.config</i>	This file stores several settings relevant to the context of a particular user working on a particular project. The purpose of storing context-specific information is that there are some parameter settings that, by their nature, are more likely to be needed in the next session, but that are not configurable in the Project Management pages.

## System Settings

Before you first log into Lustre, you must configure the system settings in the *init.config* file (refer to “Configuring System Settings” in the “Project Management” chapter of the *Autodesk Lustre User Guide*). If these system settings are not configured, Lustre uses the default system settings. The following table describes the relevant system settings that should be configured before the first login.

**NOTE** All keyword values are case-sensitive.

Parameter	Data type	Default	Function
<Locations>			
<MainProjectHome>	String		Location of the Project configuration settings folder.
<MainUserHome>	String		Location of the User configuration settings folder.

Parameter	Data type	Default	Function
<b>&lt;Wiretap&gt;</b>			
<ServerAuto>	State	On	Specifies whether Lustre automatically scans for Wiretap servers.
<WiretapServer> (within <WiretapServer Group>)	String	0.0.0.0	The IP address or DNS host name for a specific Wiretap server. If one or more <WiretapServer> keywords are set to valid Wiretap server addresses, Lustre lists the content of these servers in the browser before the results of the auto scan. If <ServerAuto> is set to OFF, only the specified Wiretap servers are listed in the browser.
<b>&lt;MonitoringAndCalibration&gt;</b>			
<DisplayType>	Enumerated (abstract data)	LCD	Specifies the monitor display type (e.g., LCD or CRT).
<Calibration_Steps>	Integer	10	Specifies the number of monitor calibration steps performed.
<b>&lt;ControlSurface&gt;</b>			
<AutodeskPanels>	State	On	When ON, this keyword enables the Autodesk Control Surface (ACS). When OFF, Lustre enables the Tangent CP100 control surface (if applicable). You must also set the path for the control surface rules file in the Panel Setup File field (refer to "System & Menu Settings" in the "Project Management" chapter of the <i>Autodesk Lustre User Guide</i> ).
<PanelIDs>		function="0" grading="0" navigation="0"	The ID numbers for the Function, Navigation, and Grading panels of the ACS. You must manually configure these keywords. If your control surface is a Tangent CP100, Lustre does not use these keywords.
<PanelIPTags>		function="101" grading="100" navigation="102"	
<b>&lt;BrowseD&gt;</b>			
<Port>	Integer	1055	All computers on the BrowseD network must use the same port to communicate.
<Username>	String	root	Administrative user on the BrowseD server.
<Password>	String	xxx	Password for the administrative user.

Parameter	Data type	Default	Function
<UseInfi>	State	Off	Switch to ON if the networking protocol to use with BrowseD is the InfiniBand.
<ReadCacheBuffer Num>	Integer	0	
<ReadCacheThread Num>	Integer	0	
<BrowsedServer> (within <BrowsedServer Group>)	String	0.0.0.0	Defines the IP address or DNS host name for a specific BrowseD server.
<SlaveRenderer>			
<HostName>	String		The IP address or DNS host name for a specific Slave Renderer machine.
<Timeout>	Integer	5000	Sets the timeout duration (in milli-seconds) of the automatic Slave Renderer detection.
<Backburner>			
<Hostname>	String		The IP address or DNS host name for a specific Backburner Manager machine.
<MatchCustomGroup>			
<MatchCustom>	Name	"AliasName" type="s"	Specifies the XML metadata field to be used by the Custom match option selected from the Browse menu. "s" represents string.
<MatchCustom>	Name	"DPXTimeCode" type="tc"	"tc" represents timecode.
<MatchCustom>	Name	"DPXkeycode" type="kk"	"kk" represents keycode.
<MatchCustom>	Name	"DPXTapeNAME" type="s"	"s" represents string.
<MatchCustom>	Name	"EDLReelName" type="s"	"s" represents string.
<MatchCustom>	Name	"DL_EDLClip_name" type="s"	"s" represents string.
<MatchCustom>	Name	"DL_edlFrameID" type="i"	"i" represents integer.
<MatchCustom>	Name	"DLEDL_startTC" type="tc"	"tc" represents timecode.
<AVIO>			
<PlayoutHighSpeed>	State	Off	When OFF, it refreshes the Player as you are performing a playout. When ON, the Player is no longer refreshed and therefore the performance of the playout improves. If you are using an IBM 6223

Parameter	Data type	Default	Function
			workstation, you must set this keyword to ON.
<WTTFirstSDLeadIn Correction>	Integer	1	Sets the delay for the SD first lead-in.
<WTTSubsequentSD LeadInCorrection>	Integer	2	Delays all the lead-ins following the SD first shot.
<WTTSDLeadIn Increment>	Integer	0	Corrects the delay after the SD third shot.
<WTTFirstHDLeadIn Correction>	Integer	0	Sets the delay for the HD first lead-in.
<WTTSubsequentHD LeadInCorrection>	Integer	0	Delays all the lead-ins following the HD first shot.
<WTTHDLeadIn Increment>	Integer	0	Corrects the delay after the HD third shot.
<Miscellaneous>			
<DisablePanScan Frame>	State	On	
<NVidiaSDISync>	State	Off	
<NVidiaPlayoutDelay>	Integer	0	
<BlockSize>	Integer	2048	
<AudioResyncTime>	Float	-1	
<LoadingSetup>	Integer	0	
<EnableKeykode Sending>	Enumerated (abstract data)	Off	
<LoginGUIGain>	Float	1.0	
<LoginGUILGamma>	Float	1.0	
<ClusterPlayDelay>	Integer	0	Available for Incinerator only.
<ClusterSmooth Playback>	State	Off	Available for Incinerator only.
<Debug>			
<DumpDLEDLPath>	String		Path to place the contents of a DLEDL when it is loaded in the timeline or Shot bin.
<DumpWiretapCreate Clip>	State	Off	When ON, the attributes of a Wiretap clip are placed into a log file each time a clip is created on a Wiretap server. The file <i>WiretapClipDump.log</i> is located in the Lustre home folder. Use this keyword for debugging only.
<FilmTypeGroup>			

---

<b>Parameter</b>	<b>Data type</b>	<b>Default</b>	<b>Function</b>
<FilmType>	Name		Various film types for AGFA, Kodak™, Eastman, and Fuji emulsions. It defines the relationship between the DPX film emulsion code and the DPX film code number.

---

# Index

## A

air conditioning requirements 15

## B

Backburner Manager  
  detecting in Lustre 95  
  detecting with Backburner Server 99  
  installing 94  
  overview 92  
Backburner Monitor  
  overview 92  
Backburner Server  
  detecting Backburner Manager 99  
  overview 92  
  starting 99  
Backburner Web Monitor, installing 94  
background rendering 5  
  components 92  
  configuring in Lustre 101  
  licensing 100  
  overview 91  
  setting up render nodes 95  
  setup, workflow 93  
  storage, mounting 97  
  workflow for setting up 93  
BIOS  
  Incinerator Nodes 23  
  QLogic 25  
  verifying and editing settings 23  
BrowseD 49  
  configuration file 76  
  license, installing 74  
  log files 86  
  monitoring 61  
  browsed.config 76  
Burn for Lustre  
  hardware and software requirements 96  
  installing and configuring 98  
  license 100  
  overview 93  
Burn for Lustre, installing and configuring 95

## C

cmanagerd log files 86  
cmanagerd.conf 76  
cmanagerdclient.conf 77

Command Line Renderer, monitoring 64  
components  
  Incinerator 5  
  installing rack-mounted 16  
configuration file  
  overview 103  
configuration files  
  BrowseD 76  
  cmanagerd 76  
  cmanagerdclient.conf 77  
configuring  
  Burn for Lustre 98  
customer support  
  contacting 3

## D

daemon  
  configuration files 76  
  log files 86  
daemons  
  BrowseD 49  
  BrowseD configuration file 76  
  cmanagerd configuration file 76  
  cmanagerdclient configuration file 77  
  manually stopping and starting 85  
  renderd 49  
  starting and stopping, Incinerator Resource  
    Manager 64  
Discreet Kernel Utility version 31  
DKU version 31  
documentation  
  conventions 2  
documentation for this release 2

## F

floating licenses  
  background rendering 100

## G

Gigabit Ethernet, function 6  
GigE switch  
  connecting Lustre Media Server, Incinerator  
    Nodes 20  
graphics driver, troubleshooting 84  
grounding hardware 15  
guidelines, hardware environment 14

## H

### hardware

- environment guidelines 14
- grounding 15
- requirements, Burn for Lustre 96
- workflow for connecting 13

## I

### Incinerator

- components 5
- configurations, expanding 7

### Incinerator Node groups, connecting to 79

### Incinerator Nodes

- BIOS 23
- connecting 20
- creating groups 53
- function 5
- grouping 52
- groups, deleting 58
- groups, modifying contents 56
- groups, modifying owner or name 55
- installing Incinerator software 47
- installing render licenses 75
- monitoring 59

### Incinerator Resource Manager

- administrator permissions, modifying 69
- daemons, starting and stopping 64
- Incinerator Nodes, creating groups 53
- Incinerator Nodes, deleting groups 58
- Incinerator Nodes, grouping 52
- Incinerator Nodes, modifying contents 56
- Incinerator Nodes, modifying owner or name of groups 55
- Incinerator Nodes, monitoring 59
- logging in 50
- Lustre Media Servers, monitoring 61
- overview 49
- rendering, monitoring 64
- starting 50
- starting and stopping the Lustre application 64
- user accounts 67
- user accounts, creating 68
- user accounts, deleting 68
- user accounts, modifying passwords 68
- user accounts, modifying rights 68
- workstations, monitoring 62

### Incinerator software installation workflow 45

### Incinerator, using in Lustre 78

### InfiniBand

- function 6
- log files 89
- management 88
- port statistics 88–89

### InfiniBand switch

- connecting Lustre Media Server, Incinerator Node 20

### installing

- Burn for Lustre 98

### IP addressing, changing 86

## K

### KVM switch

- connecting keyboard, monitor, mouse 23
- connecting Lustre Media Server, Incinerator Nodes 20

## L

### license

- background rendering, floating 100
- Burn for Lustre 100

### license server

- background rendering 100
- creating the license file 73
- installing 73
- starting 74

### licensing

- background rendering 100
- creating the license server license file 73
- installing BrowseD license 74
- installing Incinerator Node licenses 75
- installing workstation licenses workstations 76
- license codes required 72
- requesting license codes 73
- starting the license server 74
- workflow 71

### Linux version 27

### lmhostid, obtaining 72

### log files

- daemon 86
- InfiniBand 89

### Lustre

- Cluster menu 79
- detecting Backburner Manager 95
- monitoring 62
- project management 78
- real-time playback 79
- starting 78

### Lustre Media Servers

- connecting 20
- function 6
- installing Incinerator software 46
- monitoring 61

### Lustre workstation, function 5

## M

### monitor, troubleshooting 84

### mount points

- overview 93

### multicasting

- Linux 31

## N

networking  
  multicasting, Linux 31  
networking, changing IP addressing 86

## O

operating system requirements 27

## P

PDF documentation, accessing 2  
playback  
  real-time in Incinerator 80  
  real-time with Incinerator 79  
  with Incinerator 79–80  
port statistics, InfiniBand 88–89  
power requirements 15  
powering on or off, sequence for 36  
projects, setting up for Incinerator 78

## Q

QLogic BIOS 25

## R

real-time playback 79  
real-time playback, troubleshooting 84  
Red Hat Linux version 27  
render nodes  
  setting up 95  
renderd 49  
  licensing 75  
  log files 86  
  monitoring 59  
rendering, monitoring command line 64  
requirements  
  DKU 31  
  operating system 27  
  Red Hat Linux version 27

## S

services. See daemons 49

shipment, checking hardware 14  
shutdown sequence 36  
software  
  requirements for Burn for Lustre 96  
startup time  
  troubleshooting 83  
static electricity, avoiding damage 15  
storage  
  workflow for configuring 35  
support  
  contacting 3

## T

troubleshooting  
  graphics driver and monitor 84  
  startup time 83  
troubleshooting real-time playback 84

## U

user accounts  
  creating, Incinerator Resource Manager 68  
  deleting, Incinerator Resource Manager 68  
  Incinerator Resource Manager 67  
  modifying administrator permissions, Incinerator  
    Resource Manager 69  
  modifying passwords, Incinerator Resource  
    Manager 68  
  modifying rights, Incinerator Resource Manager 68

## W

workflow  
  connecting hardware 13  
  installing Incinerator software 45  
  licensing 71  
  setting up background rendering 93  
  starting Lustre 78  
  storage configuration 35  
workstations  
  connecting 19  
  function 5  
  installing Incinerator software 47  
  installing licenses 76  
  monitoring 62

