

Autodesk®
Flame® 2009

A Discreet® Systems product



User Guide

© 2008 Autodesk, Inc./Autodesk Canada Co. All rights reserved. Except as otherwise permitted by Autodesk, Inc./Autodesk Canada Co., this publication, or parts thereof, may not be reproduced in any form, by any method, for any purpose.

Autodesk® Inferno® 2009, Autodesk® Flame® 2009, Autodesk® Flint® 2009, Autodesk® Smoke® 2009, Autodesk® Backdraft® Conform 2009

Portions relating to MXF-SDK was developed by Media, Objects and Gadgets – Soluções de Software e Hardware, S.A. (<http://www.mog-solutions.com>) in co-operation with Institut für Rundfunktechnik GmbH (<http://www.irt.de>).

Portions relating to Libxalan-c 1.9.0 are Copyright © 1999-2004. The Apache Software Foundation. Licensed under the Apache License, Version 2.0 (the "License"); you may not use this file except in compliance with the License. You may obtain a copy of the License at <http://www.apache.org/licenses/LICENSE-2.0>. Unless required by applicable law or agreed to in writing, software distributed under the License is distributed on an "AS IS" BASIS, WITHOUT WARRANTIES OR CONDITIONS OF ANY KIND, either express or implied. See the License for the specific language governing permissions and limitations under the License.

Portions relating to Libxerces-c 2.6.0 are copyright 1999-2000, 2004 The Apache Software Foundation. Licensed under the Apache License, Version 2.0 (the "License"); you may not use this file except in compliance with the License. You may obtain a copy of the License at <http://www.apache.org/licenses/LICENSE-2.0>. Unless required by applicable law or agreed to in writing, software distributed under the License is distributed on an "AS IS" BASIS, WITHOUT WARRANTIES OR CONDITIONS OF ANY KIND, either express or implied. See the License for the specific language governing permissions and limitations under the License.

Portions relating to JPEG © Copyright 1991-1998 Thomas G. Lane. All rights reserved. This software is based in part on the work of the Independent JPEG Group.

Portions relating to Libnuma Copyright 2002, 2004, Andi Kleen, SuSE Labs. Libnuma is under the GNU Lesser General Public License, v 2.1.

Portions relating to Libelf v 0.97 © 2008 Michael Riepe. Distributed under the terms of the GNU Lesser General Public License, v 2.1.

Portions relating to OpenMotif Copyright © 2007 by Integrated Computer Solutions, Inc. This material may be distributed only subject to the terms and conditions set forth in the Open Publication License, v2 .3 or later (the latest version is presently available at <http://www.opencontent.org/openpub/>).

Portions relating to LAPACK © 1999. LAPACK Users' Guide Third Edition is the official reference for LAPACK.

Portions relating to BLAS © 2005. ACM Transactions on Mathematical Software.

Portions relating to MD5 Copyright © 1991-2, RSA Data Security, Inc. Created 1991. All rights reserved. License to copy and use this software is granted provided that it is identified as the "RSA Data Security, Inc. MD5 Message-Digest Algorithm" in all material mentioning or referencing this software or this function. License is also granted to make and use derivative works provided that such works are identified as "derived from the RSA Data Security, Inc. MD5 Message-Digest Algorithm" in all material mentioning or referencing the derived work. RSA Data Security, Inc. makes no representations concerning either the merchantability of this software or the suitability of this software for any particular purpose. It is provided "as is" without express or implied warranty of any kind. These notices must be retained in any copies of any part of this documentation and/or software.

Portions relating to LibGCC Copyright © 2007 The GGC Team. Distributed under the terms of the GNU General Public License (or the Lesser GPL) <http://www.gnu.org/copyleft/library.html>.

Portions relating to ALSA version 1.0.6 Copyright © 2004 Jaroslav Kysela, Abramo Bagnara, Takashi Iwai, and Frank van de Pol.

Portions relating to Audiobogus Copyright © 1998-1999, Michael Pruett (michael@68k.org).

Portions relating to Audiofile 0.2.6 Copyright © 2005 Michael Pruett. Distributed under the terms of GNU General Public License, v2.

Portions relating to Berkeley Database software Copyright ©1990-2002, Sleepycat Software. All rights reserved. Redistribution and use in source and binary forms, with or without modification, are permitted provided that the following conditions are met: 1. Redistributions of source code must retain the above copyright notice, this list of conditions and the following disclaimer. 2. Redistributions in binary form must reproduce the above copyright notice, this list of conditions and the following disclaimer in the documentation and/or other materials provided with the distribution. 3. Redistributions in any form must be accompanied by information on how to obtain complete source code for the DB software and any accompanying software that uses the DB software. The source code must either be included in the distribution or be available for no more than the cost of distribution plus a nominal fee, and must be freely redistributable under reasonable conditions. For an executable file, complete source code means the source code for all modules it contains. It does not include source code for modules or files that typically accompany the major components of the operating system on which the executable file runs. THIS SOFTWARE IS PROVIDED BY SLEEPYCAT SOFTWARE "AS IS" AND ANY EXPRESS OR IMPLIED WARRANTIES, INCLUDING, BUT NOT LIMITED TO, THE IMPLIED WARRANTIES OF MERCHANTABILITY, FITNESS FOR A PARTICULAR PURPOSE, OR NON-INFRINGEMENT, ARE DISCLAIMED. IN NO EVENT SHALL SLEEPYCAT SOFTWARE BE LIABLE FOR ANY DIRECT, INDIRECT, INCIDENTAL, SPECIAL, EXEMPLARY, OR CONSEQUENTIAL DAMAGES (INCLUDING, BUT NOT LIMITED TO, PROCUREMENT OF SUBSTITUTE GOODS OR SERVICES; LOSS OF USE, DATA, OR PROFITS; OR BUSINESS INTERRUPTION)

HOWEVER CAUSED AND ON ANY THEORY OF LIABILITY, WHETHER IN CONTRACT, STRICT LIABILITY, OR TORT (INCLUDING NEGLIGENCE OR OTHERWISE) ARISING IN ANY WAY OUT OF THE USE OF THIS SOFTWARE, EVEN IF ADVISED OF THE POSSIBILITY OF SUCH DAMAGE.
Portions relating to DIRAC Time Stretch/Pitch Shift technology licensed from The DSP Dimension, <http://www.dspdimension.com> Developed and © 2005 Stephan M. Bernsee.

Portions relating to GLEE Copyright © 2006 Ben Woodhouse. All rights reserved. Redistribution and use in source and binary forms, with or without modification, are permitted provided that the following conditions are met: 1. Redistributions of source code must retain the above copyright notice, this list of conditions and the following disclaimer as the first lines of this file unmodified. 2. Redistributions in binary form must reproduce the above copyright notice, this list of conditions and the following disclaimer in the documentation and/or other materials provided with the distribution. THIS SOFTWARE IS PROVIDED BY BEN WOODHOUSE "AS IS" AND ANY EXPRESS OR IMPLIED WARRANTIES, INCLUDING, BUT NOT LIMITED TO, THE IMPLIED WARRANTIES OF MERCHANTABILITY AND FITNESS FOR A PARTICULAR PURPOSE ARE DISCLAIMED. IN NO EVENT SHALL BEN WOODHOUSE BE LIABLE FOR ANY DIRECT, INDIRECT, INCIDENTAL, SPECIAL, EXEMPLARY, OR CONSEQUENTIAL DAMAGES (INCLUDING, BUT NOT LIMITED TO, PROCUREMENT OF SUBSTITUTE GOODS OR SERVICES; LOSS OF USE, DATA, OR PROFITS; OR BUSINESS INTERRUPTION) HOWEVER CAUSED AND ON ANY THEORY OF LIABILITY, WHETHER IN CONTRACT, STRICT LIABILITY, OR TORT (INCLUDING NEGLIGENCE OR OTHERWISE) ARISING IN ANY WAY OUT OF THE USE OF THIS SOFTWARE, EVEN IF ADVISED OF THE POSSIBILITY OF SUCH DAMAGE.

Portions of LibFreeType 2.1.19 are copyright © 2000. The FreeType Project (www.freetype.org). All rights reserved.

Portions relating to LibImageDL software are Copyright © 1991, 1999 Free Software Foundation, Inc.

Portions relating to Libpopt Copyright © 1998 Red Hat Software. Permission is hereby granted, free of charge, to any person obtaining a copy of this software and associated documentation files (the "Software"), to deal in the Software without restriction, including without limitation the rights to use, copy, modify, merge, publish, distribute, sublicense, and/or sell copies of the Software, and to permit persons to whom the Software is furnished to do so, subject to the following conditions: The above copyright notice and this permission notice shall be included in all copies or substantial portions of the Software. THE SOFTWARE IS PROVIDED "AS IS", WITHOUT WARRANTY OF ANY KIND, EXPRESS OR IMPLIED, INCLUDING BUT NOT LIMITED TO THE WARRANTIES OF MERCHANTABILITY, FITNESS FOR A PARTICULAR PURPOSE AND NONINFRINGEMENT. IN NO EVENT SHALL THE X CONSORTIUM BE LIABLE FOR ANY CLAIM, DAMAGES OR OTHER LIABILITY, WHETHER IN AN ACTION OF CONTRACT, TORT OR OTHERWISE, ARISING FROM, OUT OF OR IN CONNECTION WITH THE SOFTWARE OR THE USE OR OTHER DEALINGS IN THE SOFTWARE.

Except as contained in this notice, the name of the X Consortium shall not be used in advertising or otherwise to promote the sale, use or other dealings in this Software without prior written authorization from the X Consortium.

Portions relating to libquicktime, Copyright © 2007. Distributed under the terms of the GNU General Public License (or the Lesser GPL).

Portions relating to Mesa Copyright © 1999-2007 Brian Paul. All Rights Reserved. Permission is hereby granted, free of charge, to any person obtaining a copy of this software and associated documentation files (the "Software"), to deal in the Software without restriction, including without limitation the rights to use, copy, modify, merge, publish, distribute, sublicense, and/or sell copies of the Software, and to permit persons to whom the Software is furnished to do so, subject to the following conditions: The above copyright notice and this permission notice shall be included in all copies or substantial portions of the Software. THE SOFTWARE IS PROVIDED "AS IS", WITHOUT WARRANTY OF ANY KIND, EXPRESS OR IMPLIED, INCLUDING BUT NOT LIMITED TO THE WARRANTIES OF MERCHANTABILITY, FITNESS FOR A PARTICULAR PURPOSE AND NONINFRINGEMENT. IN NO EVENT SHALL BRIAN PAUL BE LIABLE FOR ANY CLAIM, DAMAGES OR OTHER LIABILITY, WHETHER IN AN ACTION OF CONTRACT, TORT OR OTHERWISE, ARISING FROM, OUT OF OR IN CONNECTION WITH THE SOFTWARE OR THE USE OR OTHER DEALINGS IN THE SOFTWARE.

Portions relating to Open Inventor 2.1.5-9 Copyright © 1991, 1999 Free Software Foundation, Inc.

Portions relating to Python version 2.3.3 Copyright © 2001, 2002, 2003 Python Software Foundation; All Rights Reserved.

Portions relating to XXDiff Copyright © 1999-2004, Martin Blais. All Rights Reserved.

Portions powered by Automatic Duck. © 2006 Automatic Duck, Inc. All rights reserved.

PORTIONS OF THIS PRODUCT IS LICENSED UNDER THE VC-1 PATENT PORTFOLIO LICENSE FOR THE PERSONAL AND NON-COMMERCIAL USE OF A CONSUMER TO (i) ENCODE VIDEO IN COMPLIANCE WITH THE VC-1 STANDARD ("VC-1 VIDEO") AND/OR (ii) DECODE VC-1 VIDEO THAT WAS ENCODED BY A CONSUMER ENGAGED IN A PERSONAL AND NON-COMMERCIAL ACTIVITY AND/OR WAS OBTAINED FROM A VIDEO PROVIDER LICENSED TO PROVIDE VC-1 VIDEO. NO LICENSE IS GRANTED OR SHALL BE IMPLIED FOR ANY OTHER USE. ADDITIONAL INFORMATION MAY BE OBTAINED FROM MPEG LA, L.L.C. SEE [HTTP://WWW.MPEGLA.COM](http://WWW.MPEGLA.COM).

Portions relating to Glibc file contains the copying permission notices for various files in the GNU C Library distribution that have copyright owners other than the Free Software Foundation. These notices all require that a copy of the notice be included in the accompanying documentation and be distributed with binary distributions of the code, so be sure to include this file along with any binary distributions derived from the GNU C Library.

Portions relating to X11-libs v. 6.8.2 Copyright © 1994-2003 The XFree86 Project, Inc. All Rights Reserved. Permission is hereby granted, free of charge, to any person obtaining a copy of this software and associated documentation files (the "Software"), to deal in the Software without

restriction, including without limitation the rights to use, copy, modify, merge, publish, distribute, sublicense, and/or sell copies of the Software, and to permit persons to whom the Software is furnished to do so, subject to the following conditions: The above copyright notice and this permission notice shall be included in all copies or substantial portions of the Software. THE SOFTWARE IS PROVIDED "AS IS", WITHOUT WARRANTY OF ANY KIND, EXPRESS OR IMPLIED, INCLUDING BUT NOT LIMITED TO THE WARRANTIES OF MERCHANTABILITY, FITNESS FOR A PARTICULAR PURPOSE AND NONINFRINGEMENT. IN NO EVENT SHALL THE XFREE86 PROJECT BE LIABLE FOR ANY CLAIM, DAMAGES OR OTHER LIABILITY, WHETHER IN AN ACTION OF CONTRACT, TORT OR OTHERWISE, ARISING FROM, OUT OF OR IN CONNECTION WITH THE SOFTWARE OR THE USE OR OTHER DEALINGS IN THE SOFTWARE. Except as contained in this notice, the name of the XFree86 Project shall not be used in advertising or otherwise to promote the sale, use or other dealings in this Software without prior written authorization from the XFree86 Project.

Portions relating to zlib ©1995-2004 Jean-loup Gailly and Mark Adler. This software is provided 'as-is', without any express or implied warranty. In no event will the authors be held liable for any damages arising from the use of this software.

Portions relating to Firefox 2 are © 2005-2008. Mozilla. All rights reserved. Distributed under the Mozilla Public License Version 1.1.

Autodesk® WiretapCentral™ 2008

Portions relating to Libxalan-c 1.8.0 are Copyright © 2004 The Apache Software Foundation. Licensed under the Apache License, Version 2.0 (the "License"); you may not use this file except in compliance with the License. You may obtain a copy of the License at <http://www.apache.org/licenses/LICENSE-2.0>. Unless required by applicable law or agreed to in writing, software distributed under the License is distributed on an "AS IS" BASIS, WITHOUT WARRANTIES OR CONDITIONS OF ANY KIND, either express or implied. See the License for the specific language governing permissions and limitations under the License. This product includes software developed by the Apache Software Foundation (<http://www.apache.org/>).

Portions relating to Libxerces-c 2.5.0 are Copyright © 1999-2004 The Apache Software Foundation. All rights reserved. Redistribution and use in source and binary forms, with or without modification, are permitted provided that the following conditions are met: 1. Redistributions of source code must retain the above copyright notice, this list of conditions and the following disclaimer. 2. Redistributions in binary form must reproduce the above copyright notice, this list of conditions and the following disclaimer in the documentation and/or other materials provided with the distribution. 3. The end-user documentation included with the redistribution, if any, must include the following acknowledgment: "This product includes software developed by the Apache Software Foundation (<http://www.apache.org/>)." Alternately, this acknowledgment may appear in the software itself, if and wherever such third-party acknowledgments normally appear. 4. The names "Xerces" and "Apache Software Foundation" must not be used to endorse or promote products derived from this software without prior written permission. For written permission, please contact apache@apache.org. 5. Products derived from this software may not be called "Apache" nor may "Apache" appear in their name, without prior written permission of the Apache Software Foundation. THIS SOFTWARE IS PROVIDED "AS IS" AND ANY EXPRESSED OR IMPLIED WARRANTIES, INCLUDING, BUT NOT LIMITED TO, THE IMPLIED WARRANTIES OF MERCHANTABILITY AND FITNESS FOR A PARTICULAR PURPOSE ARE DISCLAIMED. IN NO EVENT SHALL THE APACHE SOFTWARE FOUNDATION OR ITS CONTRIBUTORS BE LIABLE FOR ANY DIRECT, INDIRECT, INCIDENTAL, SPECIAL, EXEMPLARY, OR CONSEQUENTIAL DAMAGES (INCLUDING, BUT NOT LIMITED TO, PROCUREMENT OF SUBSTITUTE GOODS OR SERVICES; LOSS OF USE, DATA, OR PROFITS; OR BUSINESS INTERRUPTION) HOWEVER CAUSED AND ON ANY THEORY OF LIABILITY, WHETHER IN CONTRACT, STRICT LIABILITY, OR TORT (INCLUDING NEGLIGENCE OR OTHERWISE) ARISING IN ANY WAY OUT OF THE USE OF THIS SOFTWARE, EVEN IF ADVISED OF THE POSSIBILITY OF SUCH DAMAGE.

Portions relating to JPEG are copyright © 1991-1996, Thomas G. Lane. All Rights Reserved except as specified below. The authors make NO WARRANTY or representation, either express or implied, with respect to this software, its quality, accuracy, merchantability, or fitness for a particular purpose. This software is provided "AS IS", and you, its user, assume the entire risk as to its quality and accuracy.

Autodesk® SystemCentral 2009

Portions relating to pySerial Copyright © 2001-2004 Chris Liechti cliechti@gmx.net; All Rights Reserved.

Autodesk® Inferno® 2009, Autodesk® Flame® 2009, Autodesk® Flint® 2009, Autodesk® Smoke® 2009, Autodesk® Backdraft® Conform 2009, and Autodesk® WiretapCentral™ 2008

Portions relating to OpenExr 1.2.1 Copyright © 2004, Industrial Light & Magic, a division of Lucasfilm Entertainment Company Ltd. Portions contributed and copyright held by others as indicated. All rights reserved. Redistribution and use in source and binary forms, with or without modification, are permitted provided that the following conditions are met: Redistributions of source code must retain the above copyright notice, this list of conditions and the following disclaimer. Redistributions in binary form must reproduce the above copyright notice, this list of conditions and the following disclaimer in the documentation and/or other materials provided with the distribution. Neither the name of Industrial Light & Magic nor the names of any other contributors to this software may be used to endorse or promote products derived from this software without specific prior written permission. THIS SOFTWARE IS PROVIDED BY THE COPYRIGHT HOLDERS AND CONTRIBUTORS "AS IS" AND ANY EXPRESS OR IMPLIED WARRANTIES, INCLUDING, BUT NOT LIMITED TO, THE IMPLIED WARRANTIES OF MERCHANTABILITY AND FITNESS FOR A PARTICULAR PURPOSE ARE DISCLAIMED. IN NO EVENT SHALL THE COPYRIGHT OWNER OR CONTRIBUTORS BE LIABLE FOR ANY DIRECT, INDIRECT, INCIDENTAL, SPECIAL, EXEMPLARY, OR CONSEQUENTIAL DAMAGES (INCLUDING, BUT NOT LIMITED TO, PROCUREMENT OF SUBSTITUTE GOODS OR SERVICES; LOSS OF USE, DATA, OR PROFITS; OR BUSINESS INTERRUPTION) HOWEVER CAUSED AND ON ANY THEORY OF LIABILITY, WHETHER IN CONTRACT, STRICT LIABILITY, OR TORT (INCLUDING NEGLIGENCE OR OTHERWISE) ARISING IN ANY WAY OUT OF THE USE OF THIS SOFTWARE, EVEN IF ADVISED OF THE POSSIBILITY OF SUCH DAMAGE.

Portions relating to libtiff are Copyright © 1988-1997 Sam Leffler. Copyright © 1991-1997 Silicon Graphics, Inc. Permission to use, copy, modify, distribute, and sell this software and its documentation for any purpose is hereby granted without fee, provided that (i) the above copyright notices and this permission notice appear in all copies of the software and related documentation, and (ii) the names of Sam Leffler and Silicon Graphics may not be used in any advertising or publicity relating to the software without the specific, prior written permission of Sam Leffler and Silicon Graphics. THE SOFTWARE IS PROVIDED "AS-IS" AND WITHOUT WARRANTY OF ANY KIND, EXPRESS, IMPLIED OR OTHERWISE, INCLUDING WITHOUT LIMITATION, ANY WARRANTY OF MERCHANTABILITY OR FITNESS FOR A PARTICULAR PURPOSE. IN NO EVENT SHALL SAM LEFFLER OR SILICON GRAPHICS BE LIABLE FOR ANY SPECIAL, INCIDENTAL, INDIRECT OR CONSEQUENTIAL DAMAGES OF ANY KIND, OR ANY DAMAGES WHATSOEVER RESULTING FROM LOSS OF USE, DATA OR PROFITS, WHETHER OR NOT ADVISED OF THE POSSIBILITY OF DAMAGE, AND ON ANY THEORY OF LIABILITY, ARISING OUT OF OR IN CONNECTION WITH THE USE OR PERFORMANCE OF THIS SOFTWARE.

Portions relating to libffmpeg Copyright © 2003-2006, Fabrice Bellard.

Portions relating to LAME 3.97 Copyright © 2006 Mark Cheng. www.mp3dev.org. Distributed under the terms of the GNU General Public License (or the Lesser GPL) <http://www.gnu.org/copyleft/library.html>. PORTIONS RELATING TO H. 264 IS LICENSED UNDER THE AVC PATENT PORTFOLIO LICENSE FOR THE PERSONAL AND NON-COMMERCIAL USE OF A CONSUMER TO (i) ENCODE VIDEO IN COMPLIANCE WITH THE AVC STANDARD ("AVC VIDEO") AND/OR (ii) DECODE AVC VIDEO THAT WAS ENCODED BY A CONSUMER ENGAGED IN A PERSONAL AND NON-COMMERCIAL ACTIVITY AND/OR WAS OBTAINED FROM A VIDEO PROVIDER LICENSED TO PROVIDE AVC VIDEO. NO LICENSE IS GRANTED OR SHALL BE IMPLIED FOR ANY OTHER USE. ADDITIONAL INFORMATION MAY BE OBTAINED FROM MPEG LA, L.L.C. SEE [HTTP://WWW.MPEGLA.COM](http://WWW.MPEGLA.COM).

PORTIONS OF THIS PRODUCT IS LICENSED UNDER THE MPEG-4 VISUAL PATENT LICENSE PORTFOLIO LICENSE FOR THE PERSONAL AND NON-COMMERCIAL USE OF A CONSUMER FOR (i) ENCODING VIDEO IN COMPLIANCE WITH THE MPEG-4 VISUAL STANDARD ("MPEG-4 VIDEO") AND/OR (ii) DECODING MPEG-4 VIDEO THAT WAS ENCODED BY A CONSUMER ENGAGED IN A PERSONAL AND NON-COMMERCIAL ACTIVITY AND/OR WAS OBTAINED FROM A VIDEO PROVIDER LICENSED BY MPEG LA TO PROVIDE MPEG-4 VIDEO. NO LICENSE IS GRANTED OR SHALL BE IMPLIED FOR ANY OTHER USE. ADDITIONAL INFORMATION INCLUDING THAT RELATING TO PROMOTIONAL, INTERNAL USES AND LICENSING MAY BE OBTAINED FROM MPEG LA, L.L.C. SEE [HTTP://WWW.MPEGLA.COM](http://WWW.MPEGLA.COM).

PORTIONS OF THIS PRODUCT IS LICENSED UNDER THE MPEG-2 PATENT PORTFOLIO LICENSE ANY USE OF THIS PRODUCT OTHER THAN CONSUMER PERSONAL USE IN ANY MANNER THAT COMPLIES WITH THE MPEG-2 STANDARD FOR ENCODING VIDEO INFORMATION FOR PACKAGED MEDIA IS EXPRESSLY PROHIBITED WITHOUT A LICENSE UNDER APPLICABLE PATENTS IN THE MPEG-2 PATENT PORTFOLIO, WHICH LICENSE IS AVAILABLE FROM MPEG LA, L.L.C., 250 STEELE STREET, SUITE 300, DENVER, COLORADO 80206.

Portions relating to MPEG Layer- 3, supply of this product does not convey a license under the relevant intellectual property of Thomson multimedia and/or Fraunhofer Gesellschaft nor imply any right to use this product in any finished end user or ready-to-use final product. An independent license for such use is required. For details, please visit <http://www.mp3licensing.com>.

Trademarks

The following are registered trademarks or trademarks of Autodesk, Inc., in the USA and other countries: 3DEC (design/logo), 3December, 3December.com, 3ds Max, ActiveShapes, Actrix, ADI, Alias, Alias (swirl design/logo), AliasStudio, AliasWavefront (design/logo), ATC, AUGI, AutoCAD, AutoCAD Learning Assistance, AutoCAD LT, AutoCAD Simulator, AutoCAD SQL Extension, AutoCAD SQL Interface, Autodesk, Autodesk Envision, Autodesk Insight, Autodesk Intent, Autodesk Inventor, Autodesk Map, Autodesk MapGuide, Autodesk Streamline, AutoLISP, AutoSnap, AutoSketch, AutoTrack, Backdraft, Built with ObjectARX (logo), Burn, Buzzsaw, CaiCE, Can You Imagine, Character Studio, Cinestream, Civil 3D, Cleaner, Cleaner Central, ClearScale, Colour Warper, Combustion, Communication Specification, Constructware, Content Explorer, Create>what's>Next> (design/logo), Dancing Baby (image), DesignCenter, Design Doctor, Designer's Toolkit, DesignKids, DesignProf, DesignServer, DesignStudio, DesignStudio (design/logo), Design Web Format, Design Your World, Design Your World (design/logo), DWF, DWG, DWG (logo), DWG TrueConvert, DWG TrueView, DXF, EditDV, Education by Design, Exposure, Extending the Design Team, FBX, Filmbox, FMDesktop, Freewheel, GDX Driver, Gmax, Heads-up Design, Heidi, HOOPS, HumanIK, i-drop, iMOUT, Incinerator, IntroDV, Inventor, Inventor LT, Kaydara, Kaydara (design/logo), LocationLogic, Lustre, Maya, Mechanical Desktop, MotionBuilder, Mudbox, NavisWorks, ObjectARX, ObjectDBX, Open Reality, Opticore, Opticore Opus, PolarSnap, PortfolioWall, Powered with Autodesk Technology, Productstream, ProjectPoint, ProMaterials, Reactor, RealDWG, Real-time Roto, Recognize, Render Queue, Reveal, Revit, Showcase, ShowMotion, SketchBook, SteeringWheels, StudioTools, Topobase, Toxik, ViewCube, Visual, Visual Bridge, Visual Construction, Visual Drainage, Visual Hydro, Visual Landscape, Visual Roads, Visual Survey, Visual Syllabus, Visual Toolbox, Visual Tugboat, Visual LISP, Voice Reality, Volo, Wiretap, and WiretapCentral.

The following are registered trademarks or trademarks of Autodesk Canada Co. in the USA and/or Canada and other countries: Backburner, Discreet, Fire, Flame, Flint, Frost, Inferno, Multi-Master Editing, River, Smoke, Sparks, Stone, and Wire.

Automatic Duck and the duck logo are trademarks of Automatic Duck, Inc. All other brand names, product names or trademarks belong to their respective holders.

FFmpeg is a trademark of Fabrice Bellard, originator of the FFmpeg project.

All other brand names, product names or trademarks belong to their respective holders.

Disclaimer

THIS PUBLICATION AND THE INFORMATION CONTAINED HEREIN IS MADE AVAILABLE BY AUTODESK, INC./AUTODESK CANADA CO., "AS IS." AUTODESK, INC. DISCLAIMS ALL WARRANTIES, EITHER EXPRESS OR IMPLIED, INCLUDING BUT NOT LIMITED TO ANY IMPLIED WARRANTIES OF MERCHANTABILITY OR FITNESS FOR A PARTICULAR PURPOSE REGARDING THESE MATERIALS.

Published by: Autodesk, Inc.
111 McInnis Parkway
San Rafael, CA 94903, USA

Images Courtesy of: Absolute Post, Asylum Visual Effects, B Sky B Creative Services, Behavior Communications Inc., Buzz Image Group, Inc., Casablanca, Click 3x, Creative Bubble, Das Werk, Digital Lab, Duckling A-S, Efe-x S.A, Fischer Edit, Gravity Visual Effects Canada, Les Films Stupefiants, Optimus, Quietman, Syndicate Ent. - Syndicate Technologies, Technicolor (formerly Toybox), The House, The Post Group, The Syndicate, Topix, Version 2

Title: Autodesk Flame 2009 User Guide

Document Version: 1

Date: April 09, 2008

Contents

	Part 1: Before You Begin	1
Chapter 1	Introduction	3
	Welcome to Flame	3
	Notation Conventions	4
	Related Documentation	4
	Contacting Customer Support	7
Chapter 2	Compatibility	9
	About Compatibility	9
	Upgrade Compatibility	10
	Backward Compatibility	13
	Compatibility	14
	Compatibility with Previous Versions of Products	16
	Combustion Compatibility	16
	3ds Max Compatibility	17
	Part 2: Getting Started	19
Chapter 3	Getting Started	21
	About This Chapter	21

	Flame Basics	22
	Inputting Media	24
	Working with EDLs	25
	Project and Media Management	25
	Pre-Processing	25
	Editing	26
	Effects	27
	Batch Processing	28
	Managing Your Work Environment	28
	Finishing the Project	29
Chapter 4	The Desktop	31
	About the Desktop	31
	Selecting Clips to Apply a Desktop Command	43
	Selecting Clips to Load Them into a Module	43
	Using the Desktop Module Editor	45
	Working with Clips on the Desktop	45
	Locking and Unlocking Reels	55
	Locking Clips to Prevent Changes	56
	Naming Clips, Reels, and Desktops	58
	Moving, Copying, and Deleting Clips on the Desktop	60
	Undoing and Redoing Operations	68
	Calculating Values for Numeric Fields	68
	Picking Colours	71
	Searching the Desktop	77
	Navigating the Filesystem	82
Chapter 5	Player Essentials	93
	About the Player	93
	Playing Clips in the Player	94
	Setting Player Display Options	99
Chapter 6	Module Essentials	107
	About Modules	107
	Accessing Modules	108
	Viewing Clips in the Image Window	111
	Setting Image Window Display Options	116
	Part 3: Inputting and Outputting Media	141
Chapter 7	Clip Input/Output Using a VTR	143
	About Clip Input and Output Using a VTR	144
	Configuring Hardware For Clip Input and Output Using a VTR	145

	Configuring Software For Clip Input and Output Using a VTR	145
	Inputting Clips From a VTR	146
	Outputting Clips To a VTR	153
	Monitoring Video During Clip Input and Output Operations	161
	Setting Input and Output In and Out Points	162
	Inputting and Outputting a Live Video Signal	163
	Working with Multi-Format Input and Output	164
	Inputting and Outputting HD Material	168
	Generating Proxies	168
	Capturing Proxies Only	169
	Capturing Material with Variable Frame Rate	170
	Controlling a VTR	171
	Adjusting Audio Gain on Clip Output	174
	Setting Video Input and Output Engineering Menu Controls	175
	Inputting and Outputting with Headroom	180
	Capturing 60i Material with 2:3 Pulldown Removal	182
	Configuring Dual-Serial Link I/O on Linux Workstations	184
Chapter 8	Clip Input/Output Using HSDL Devices	187
	About HSDL Input and Output	187
	Setting Up Hardware for HSDL Input and Output	188
	Configuring Software for HSDL Input and Output	189
	Inputting Clips From an HSDL Device	189
	Outputting Clips To an HSDL Device	191
	Setting Video Input and Output Engineering Menu Options	191
Chapter 9	Importing Media Files	193
	About Importing Media Files	193
	Supported File Formats	194
	About Soft-Import and Proxies	199
	About the Import Image Menu Options	201
	Importing and Soft-Importing Image Files	210
	Importing DPX File Sequences for Data Conform	213
	Importing OpenEXR Files	218
	Importing RGBA Files	220
	Importing Adobe Photoshop Files	222
	Importing and Soft-Importing Video Files	224
	Importing and Soft-Importing in the Background	227
	Importing and Soft-Importing Audio Files	229
	Deleting Media Files From the Filesystem Via Import Image	232
Chapter 10	Exporting Media Files	233
	About Exporting Media Files	233
	Supported File Formats	234

	About the Export Image Menu Options	237
	Exporting Image Files	245
	Exporting RGBA Image Files	248
	Exporting DPX Files	249
	Exporting Video Files	251
	Working with Codec Profiles	254
	Exporting Image Files in the Background	258
	Exporting Audio Files	259
	Exporting Media to Cleaner XL for Encoding	264
	Deleting Media Files From the Filesystem Via Export Image	268
Chapter 11	Unlinking and Relinking Media and Clips	269
	About Unlinking and Relinking Media and Clips	269
	Unlinking Media from Clips in the Clip Library	270
	Reformatting Clips	273
	Reformatting Examples	278
	Recapturing Media	280
	Relinking Media to Clips	289
Chapter 12	Processing and Publishing	291
	About Processing and Publishing	291
	Types of Publishing	292
	About the Publish Tool	294
	Publishing a Clip Using the Publish Tool	296
	Publishing in the Background	298
	Managing the Background Import/Export Queue	300
	Processing Soft Effects and Batch FX	302
	Processing Clips and Proxies	305
	Processing in Modules	307
	Writing Media to the Framestore Using the Stonifise Tool	308
	Using the Stonifise Tool in the Background	309
	Consolidating Clips	311
	Committing Soft Clips, History, or Audio	312
	Compacting Clips	313
	Part 4: Working with EDLs	315
Chapter 13	About EDL Files	317
	About EDL Files	317
	Supported EDL Formats	318
	About DLEDL Files	319
	Working with EDLs	319

Chapter 14	Importing EDL Files	321
	About Importing EDL Files	321
	About the Import EDL Menu	322
	About the Load EDL Menu	334
	Importing EDLs	335
	Importing EDLs at Non-Native Frame Rates	337
	Importing EDLs with Varicam Information	338
	Converting EDLs	339
	Loading File-based EDLs	340
	Searching EDLs	346
	Closing EDLs	347
Chapter 15	Creating and Editing EDL Files	349
	About Creating and Editing EDLs	349
	About EDL Editing Commands	350
	Creating an EDL	360
	Editing an EDL	361
	Creating and Editing DLEDLs	370
	Saving EDLs and Tape Lists	375
Chapter 16	Capturing and Importing Media Using EDLs	377
	About Capturing and Importing Media Using EDL Files	377
	About the Auto-Capture Menu	378
	Capturing Clips Using an EDL	380
	Importing Files Using an EDL	385
	Assembling EDLs	386
	Viewing Captured and Assembled Material	389
Chapter 17	Exporting EDLs	393
	About Generating and Outputting EDLs	393
	About the Export EDL Menu	394
	Generating EDLs	399
	Outputting EDLs	401
Chapter 18	Timecode and Keycode	403
	About Timecode and Keycode	403
	Displaying Timecode and Keycode	405
	About the Timecode Calculator	409
	About the Keycode Calculator	410
	About the Change TC/KC/Rate Tools	413
	Changing Timecode	418
	Changing Keycode	419
	Copying Keycode	421

	Changing Frame Code Mode	421
	Manually Assigning Timecode and Keycode on Import	423
	Removing Conflicts Between Clips in Timecode or Keycode	424
	About the Burn In Menu	425
	Burning-in Clip Information	428
Chapter 19	Importing Final Cut Pro XML	431
	About Importing XML from Final Cut Pro	431
	Workflow	432
	Logging and Capturing from Tape in Final Cut Pro	433
	Exporting Sequences from Final Cut Pro	433
	Importing Final Cut Pro XML	436
	Relinking to File-based Media	439
	Recapturing Media From Tape	440
	Optimizing the Recapture of Footage Referenced in XML Files	442
	Supported and Unsupported Effects	443
Chapter 20	Importing Subtitle XML	465
	About Subtitle XML	465
	Workflow	466
	Importing Subtitle XML Files	466
	Adding Subtitle XML Files to the Timeline	468
	Editing Subtitle XML Files	469
	Subtitle XML Syntax	470
Chapter 21	Importing AAF Files	481
	About Importing Advanced Authoring Format Files	481
	Workflow	482
	Preparing Sequences Cut in Avid for AAF Import	482
	Importing AAF Files	484
	Relinking to File-based Media	486
	Optimizing the Recapture of Footage Referenced in AAF Files	488
	Supported and Unsupported Transitions and Effects	489
Chapter 22	Importing and Exporting OMF Files	499
	About OMF Files	499
	OMF Project Workflow	500
	Importing OMF Files	500
	Exporting OMF Files	502
	Supported and Unsupported Transitions and Effects	504
	Part 5: Project and Media Management	519

Chapter 23	Managing Projects and Users	521
	About Projects and Users	521
	Selecting a Project and User on Start-up	525
	Creating a Project	526
	Modifying a Project	538
	Deleting a Project	539
	Managing Proxies	541
	Auto-Connecting Clip Libraries Belonging to Other Projects	545
	Creating and Loading a User and Sharing User Preferences	545
	Modifying a User	548
	Deleting a User	549
	Loading Different Projects and Users during a Work Session	551
	About Multi-Format Projects	552
	Working with Remote Framestores	552
Chapter 24	Clip Libraries	555
	About Clip Libraries	555
	Creating Clip Libraries	557
	Opening Clip Libraries	558
	Using the Dual Library View	559
	Saving to Clip Libraries	561
	Viewing Entries in Clip Libraries	564
	Selecting Entries	580
	Searching for Clips	582
	Organizing Clips	584
	Loading Clips to the Desktop	591
	Copying Local and Remote Clip Libraries to Your Current Project	593
	Troubleshooting Lock Files	600
Chapter 25	Archiving	603
	About Archiving	604
	Choosing a Medium for Archiving	604
	Supplementing Archives with System Drive Backups	606
	Archiving and Restoring Mixed Resolution Projects	608
	Media Archiving Workflow	609
	Project Setup Archiving Workflow	610
	Configuring Hardware	610
	Configuring Software	612
	Accessing the Archive Menu	613
	Estimating Archive Size	615
	Creating a VTR Archive	618
	Creating a Tape Archive	625
	Creating a File Archive	627

	Archiving Soft-Imported Clips	629
	Archiving to Multiple Tapes	630
	Opening an Archive	631
	Saving to an Archive	634
	Closing an Archive	640
	Managing Archives	641
	Browsing an Archive	642
	Searching in an Archive	647
	Appending Entries to an Existing Archive	648
	Deleting Entries from an Archive	649
	Archive Compatibility	649
	Setting Preferences When Restoring Archives from Previous Versions	650
	Recovering an Archive	653
	Archiving and Restoring Setups	655
	Optimizing Archiving Operations	657
	 Part 6: Pre-processing	 661
Chapter 26	Resize	663
	About Resize	664
	Resizing on Import, Export, or in a Clip Library	665
	Resizing in the Resize Module	667
	Resizing in Batch	668
	Soft Resizing a Clip	678
	Changing Views in Resize and in Batch	679
	Resize Settings	681
	Resizing from Source Using the Crop Box	685
	Resizing to Destination Using the Crop Box	687
	Animating Resize Settings	688
	Saving and Loading Resize Setups	689
	Getting Dynamic Feedback in Result View	693
	Processing Clip Handles When Working with Soft Clips	694
	Resetting All Resize Settings to Default Values	695
	Changing the Appearance of the Crop Box	696
	Changing the Padding Colour	697
	Setting Default Image Resolution Characteristics on Import	698
 Chapter 27	 2:3 Pulldown	 703
	About 2:3 Pulldown	703
	Capturing Film-Based Media with 2:3 Pulldown Removal	705
	Capturing Film-Based Media with 2:3 Pulldown Using EDLs	708
	Saving and Loading the Tape List	710
	Removing and Inserting Pulldown on the Desktop	712

	Monitoring Dual Timecodes and 2:3 Pulldown	715
	Outputting a Clip to Tape with 2:3 Pulldown Insertion	717
	Exporting EDLs with 2:3 Pulldown Insertion	718
Chapter 28	Video Field Management	719
	About Interlaced Video	719
	Accessing the Video Menu	720
	Managing Field Dominance	720
	Deinterlacing and Interlacing Clips	725
	Merging Fields	727
Chapter 29	Colour Management with LUTs	729
	About Colour Management	729
	General Workflow for LUTs	732
	Workflow for Custom 1D LUTs	733
	Using LUTs Created Outside of Flame	733
	Viewing Clips with 3D LUTs	738
	Processing Clips with 3D LUTs	742
	Applying a LUT on Import or Export	744
	Accessing the LUT Editor	745
	Creating Custom 1D LUTs	749
	Saving LUT Editor Setups	766
	Loading LUT Editor Setups	767
	Exporting LUTs	768
	Converting OpenEXR Images	770
Chapter 30	Adding and Removing Film Grain	773
	About Film Grain	773
	Removing Grain from a Clip	774
	Adding Grain to a Clip	779
	Matching Grain between Clips	788
	Adding Grain with a Matte	792
	Defining the DeGrain and ReGrain Area	794
	Saving and Loading Grain Management Setups	795
	Part 7: Managing Your Work Environment	797
Chapter 31	Saving Setups and Preferences	799
	About Setups and Preferences	799
	Accessing Directories	800
	Saving, Loading, and Deleting Items	802
	Setting the Default Preferences	805

Chapter 32	Clip History	807
	About Clip History	807
	Modifying a Clip in its Last Module	809
	Modifying Clip History in Batch	810
	Managing Clips with Clip History	813
	Saving and Archiving Clips with Clip History	818
	Compatibility between Autodesk Products	818
	Clip History Functionality	823
	Clip History Features Per Product	824
Chapter 33	Setting Preferences	827
	About Preferences	827
	Accessing the Preferences Menu	828
	Project Management Preferences	828
	Preview Preferences	829
	Pointer Preferences	830
	User Interface Preferences	831
	Documentation Preferences	834
	Tooltips Preferences	835
	Miscellaneous Preferences	835
	General Preferences	836
	Timeline Preferences	841
	Desktop Preferences	848
	Audio Preferences	853
	Storage Preferences	860
	LUT Preferences	861
Chapter 34	Managing Hot Keys	863
	About the Hot Key Editor	863
	Determining a Button's Current Hot Key	865
	Hot Key Errors	865
	Accessing the Hot Key Editor	865
	Searching the Hot Key Catalogue	868
	Editing Hot Keys	868
	Creating New Local Hot Keys	870
	Managing Hot Keys	870
Chapter 35	Installing Fonts	873
	About Fonts in Flame	873
	Installing Adobe Postscript Type 1 Fonts	875
	Installing Other Supported Fonts	876
Chapter 36	Utilities	877

	About Utilities	878
	Volume Integrity Check	879
	Finding and Deleting Invalid Frames	880
	Disk Testing Utility	882
	Log Files	882
	Getting Started with the Command Line Utilities	885
	Command Line Parameters	887
	cmtool	890
	dlfsdump -fs	894
	list_framestore	895
	to_framestore	896
	from_framestore	899
	imcopy	901
	iminfo	911
	fcof	912
	publishTool	913
	stonifiseTool	915
	vstat	916
	vic	917
Chapter 37	Command Line Start-up and Exit Options	919
	Starting Flame	919
	Exiting Flame	923
	Initialising the Tablet	923
	Killing Processes	923
	Part 8: Editing	925
Chapter 38	Editing Essentials	927
	Introduction	927
	About Desktop Editing	928
	About Player Timeline Editing	928
	About Batch Timeline Editing	928
	Editing Operations Table	929
	Basic Editing Concepts	930
Chapter 39	Editing on the Desktop	935
	About Editing on the Desktop	935
	Accessing the Editing Menu	937
	Gestural Editing on the Desktop	939
	Cutting Clips	943
	Splicing Clips	948
	Inserting Frames and Clips	951
	Replacing Frames and Clips	954

	Matching Soft Clips with Their Source Clips	956
	Repeating Frames in a Clip	958
	Reversing Frame Order in a Clip	959
	Swapping Shots	961
	Consolidating Clips	963
	Committing Soft Clips	965
	Force Rendering Clips	966
Chapter 40	Navigating the Timeline	969
	About Timelines	969
	Accessing the Timeline	970
	Timeline Interface	971
	Manipulating the Timeline	972
	Playing the Timeline	975
	Track Basics	978
	Element Basics	983
	Searching for Timeline Elements	989
	Maintaining Sync between Elements	992
	Patching Video and Audio Channels	997
	Setting In Points and Out Points	1003
	Marking Frames of Interest	1007
	Creating a Cut	1011
	Swapping Batch Timeline Elements	1012
	Matching Elements with Their Source Clip	1013
Chapter 41	Editing to the Batch Timeline	1015
	About Editing to the Timeline	1015
	Batch Timeline Workflow	1016
	Setting Record and Source Clips	1019
	Placing Shots Gesturally on the Timeline	1021
	Previewing the Placement of Shots on the Timeline	1024
	Inserting Clips into an Edit Sequence	1025
	Overwriting Clips in an Edit Sequence	1027
	Replacing Shots	1028
	Performing a Three-Point Edit	1030
	Performing a Four-Point Edit	1031
	Removing Elements from an Edit Sequence	1032
Chapter 42	Vertical Editing	1035
	About Vertical Editing	1035
	Vertical Editing Interface	1036
	Creating Layers	1037
	Layer Basics	1038
	Controlling the Transparency of Gaps	1041

	Working with Containers	1041
Chapter 43	Trimming Shots	1045
	About Trimming	1045
	Trimming Examples	1048
	Head, Tail, and Offset Information	1049
	Using the Trim Cursors	1051
	Locking Segments While Trimming	1051
	Linking Transitions and Cuts	1052
	Keyboard Trimming	1053
	Trimming Segments Gesturally	1054
	Trimming Dissolves	1058
	Trimming Audio Tracks	1059
	Sliding a Segment	1059
	Slipping a Segment	1062
	Trim Cursor Review	1063
Chapter 44	Dissolves and Wipes	1065
	About Dissolves and Wipes	1065
	Creating Dissolves on the Desktop	1066
	Creating Dissolves on the Timeline	1078
	Creating Wipes	1082
	Using the Wipe Schematic	1094
	Using Templates for SMPTE Wipes	1104
	Creating an Axis Transition	1107
	Copying Transitions	1109
Chapter 45	Soft Effects	1111
	About Soft Effects	1112
	Processing Order of Soft Effects	1112
	Creating Soft Effects	1115
	Accessing the Soft Effect Editors	1118
	Creating Axis Soft Effects	1122
	Creating Wipe Soft Effects	1132
	Creating Sparks Soft Effects	1133
	Creating Colour Correction Soft Effects	1134
	Creating a Timewarp Soft Effect	1135
	Creating a Blend Soft Effect	1136
	Creating a Resize Soft Effect	1137
	Creating a Text Soft Effect	1138
	Trimming Animated Soft Effects	1144
	Creating Gap Effects	1145
	Linking Soft Effects	1149
	Copying Soft Effects	1149

	Muting Soft Effects	1150
	Deleting Soft Effects	1151
Chapter 46	Timewarps	1153
	About Timewarps	1153
	Creating Timewarps on the Desktop	1154
	Creating and Modifying Timewarps in the Timelines	1160
	Motion Estimation Using Batch Nodes	1174
Chapter 47	Managing Timeline Media	1179
	About Managing Media on the Timeline	1179
	Identifying the Status of Timeline Elements	1180
	Consolidating Elements on the Timeline	1181
	Committing Clips on the Timeline	1182
	Hard Committing Specific Soft Effects	1183
	Merging Timeline Layers	1183
	Unlinking Clips on the Timeline	1184
	Locking Processed Timeline Elements	1185
	Compacting Soft Effects	1186
	Partial Processing of the Timeline	1187
	Managing Edited Clips in Batch	1188
Chapter 48	Audio	1195
	About Working with Audio	1195
	About Working with Dolby E	1198
	Accessing the AudioDesk	1200
	About the AudioDesk Controls	1201
	Scrubbing Audio in the Player	1203
	Working with Audio in the Timeline	1204
	About Audio Soft Effects	1214
	Using Input Strips	1221
	About EQ Filter Effects	1225
	Adjusting EQ Settings on the EQ Desk	1232
	Animating AudioDesk Effects	1239
	About Auxiliary Effects	1241
	Adjusting Settings on the Auxiliary Effects Desk	1245
	Using Output Strips	1246
	Using the Audio Tools	1248
	Part 9: Batch Processing	1257
Chapter 49	Batch Overview	1259
	About Batch	1259

	Batch Workflow	1262
	Accessing the Batch Menu	1262
	Viewing the Batch Schematic	1267
	Accessing Modules from Batch	1272
	Creating Animations with the Batch Universal Editor	1273
	Offsetting Clips with the Timing View	1274
	Using the BFX View	1278
	Setting Batch Preferences	1278
Chapter 50	Batch Processing	1283
	Assembling a Process Tree	1283
	Manipulating Nodes	1298
	Previewing Results	1313
	Outputting and Exporting Batch Results	1322
Chapter 51	Batch: Node Reference	1329
	About Batch Nodes	1330
	2D Histogram Node	1332
	3D Keyer Node	1332
	Action Node	1333
	Add Pulldown and Remove Pulldown Nodes	1335
	Auto Matte Node	1336
	Auto Stabilize Node	1336
	Average Node	1339
	BFX Output Node	1339
	Burn-In Letterbox Node	1341
	Burn-in Timecode Node	1342
	Colour Correct Node	1342
	Colour Curves Node	1342
	Coloured Frame Node	1343
	Colour Warper Node	1344
	Combine Node	1344
	Compound Node	1345
	Deal Node	1345
	Degrain and Regrain Nodes	1345
	DeInterlace and Interlace Nodes	1346
	Desk Node	1346
	Difference Matte Node	1346
	Distort Node	1347
	Edge Node	1347
	Export Node	1347
	Field Merge Node	1348
	Filter Node	1348
	Flip Node	1349
	Glow Node	1349

GMask Node	1350
Import Node	1350
Keyer Node	1351
Lens Distort Node	1352
Library Node	1356
Logic Op Node	1356
Luminance Key Node	1357
LUT Editor Node	1357
Master Keyer Node	1358
Matte Curves Node	1359
Modular Keyer Node	1359
Monochrome Node	1360
Motion Analysis Node	1360
Motion Blur Node	1362
MUX Node	1364
Negative Node	1364
Notes Node	1365
Optics Node	1365
Output Node	1365
Paint Node	1368
Posterise Node	1369
Quick Composite Node	1369
Resize Node	1369
RGB Blur Node	1370
Spark Node	1372
Text Node	1373
Vector Viewer Node	1373
Chapter 52 Batch FX	1375
About Batch FX	1375
Creating Batch FX	1376
Creating One Clip Per Timeline Layer	1386
Converting Soft Effects to Batch Nodes	1388
Viewing Batch FX in Context	1397
Offsetting the Starting Frame of a BFX Clip	1400
Outputting from a BFX Output Node	1402
Editing Batch FX	1409
Navigating Batch Setups	1410
Expanding Batch FX	1417
Copying Batch FX	1419
Deleting Batch FX	1420
Previewing Batch FX	1420
Part 10: Effects	1423

Chapter 53	Processing and Formatting Commands	1425
	Accessing the Processing Menu	1426
	Simulating the Motion Blur of a Moving Object	1428
	Creating Compound Images	1431
	Flipping Images	1432
	Using Logical Operations	1433
	Generating a Difference Matte	1437
	Using the Auto Matte Command	1439
	Creating a Monochrome Clip	1440
	Creating a Negative Clip	1440
	Modifying the Luma and Chroma of a Clip	1441
	Creating Coloured Frames	1442
	Accessing the Format Menu	1444
	Using Separate and Combine	1446
	Dealing and Interleaving Clips	1448
Chapter 54	Colour Corrector	1451
	About Colour Correcting	1451
	Accessing the Colour Corrector	1452
	Viewing Clips	1455
	Changing Colour Corrector Settings	1457
	Colour Sampling	1462
	Matching Colours	1465
	Colour Correcting from the Main Menu	1467
	Adjusting the Colour Range	1475
	Remapping Colour Values	1479
	Animating a Colour Correction	1480
	Processing Colour Changes	1481
Chapter 55	Colour Warper	1483
	About the Colour Warper	1483
	Accessing the Colour Warper	1485
	Setting Up Your Work Environment	1488
	Sampling Clips in the Image Window	1501
	Selecting Colour Ranges for Colour Correction	1502
	Correcting Colour Imbalances	1510
	Improving Contrast	1515
	Matching Colours in Clips	1523
	Performing Hue Shifts	1526
	Creating Colour Casts	1527
	Readjusting Colour After a Colour Correction	1528
	Removing Colour Spill	1529
	Creating Subsetups	1531

Chapter 56	Filters	1535
	About Filters	1535
	Accessing the Filter Menu	1535
	Applying a Filter to a Clip	1536
	Filter Library	1537
	Customizing Filters	1538
Chapter 57	Keyer	1545
	About the Keyer	1545
	Accessing the Keyer	1546
	Creating and Refining a Key	1548
	Creating a Key by Extracting a Single Colour	1560
	Creating a Key by Extracting a Range of Colours	1562
	Creating a Key by Setting the Luminance	1568
	Adjusting the Luminance of the Key	1569
	Refining the Key	1576
	Colour Correcting the Key	1592
	Animating Your Key	1594
	Additional Keying Techniques	1595
	Resetting Keys	1597
	Processing Clips	1598
Chapter 58	Modular Keyer	1603
	About the Modular Keyer	1603
	Accessing the Modular Keyer	1604
	Using Nodes	1629
	Blend Nodes	1647
	Animation in the Modular Keyer	1658
	Nodes Placement Table	1658
Chapter 59	3D Keyer	1661
	About the 3D Keyer	1661
	Accessing the 3D Keyer	1662
	Creating a Precise Key	1665
	Mastering the RGB Viewer	1681
	Animating Key Elements	1700
	More Keying Techniques	1703
	Setting 3D Keyer Preferences	1706
Chapter 60	Garbage Masks	1707
	About Garbage Masks	1708
	Accessing the Garbage Mask Menu	1710
	About Garbage Mask Options	1712

	Setting Mask Options	1714
	About Drawing Options	1715
	Setting Drawing Options	1716
	Drawing a Mask	1717
	Adjusting the Number of Points in Freehand Segments	1722
	Viewing Nodes in the Schematic	1722
	Changing the Priority Order of Masks	1723
	Transforming the Mask	1724
	Manipulating Vertices and Tangents	1725
	Animating Garbage Masks	1728
	Applying Motion Blur to Garbage Masks	1738
	Blurring a Stationary Garbage Mask	1740
	Rendering Garbage Masks in Interlaced Mode	1740
	Using Multiple Garbage Masks	1741
	Refining the Mask	1743
	Saving Garbage Mask Setups	1757
	Loading Garbage Mask Setups	1758
	Preset Garbage Mask Setups	1759
	Importing and Exporting Raw Setup Files	1760
Chapter 61	Compositor and Optics	1763
	About the Compositor and Optics	1763
	Accessing the Compositor	1764
	Cropping the Front Clip	1767
	Controlling the Camera in the Scene	1769
	Setting Front Clip Attributes	1770
	Creating Motion Paths	1773
	Tracking Clips	1774
	Colour Correcting Clips	1775
	Processing Your Clips	1776
	Quick Compositing	1777
	Creating Glow Effects Using Optics	1778
	Animating Glow Effects	1779
Chapter 62	Tracking and Stabilizing	1781
	About Tracking and Stabilizing	1781
	Accessing the Stabilizer	1782
	How the Stabilizer Works	1782
	Working with Trackers	1785
	Stabilizing	1793
	Smoothing Out Camera Motion	1798
	Tracking	1799
	Tracking Difficult Shots and Correcting Errors	1805
	Setup Options	1814
	Copying Shift Channels	1818

	Importing and Exporting Data	1819
Chapter 63	Distort	1821
	About Distort	1822
	Accessing the Distort Menu	1825
	Using Distort's Views and Clip Display	1830
	Creating Splines	1833
	Editing Splines	1839
	Using Distort's Schematic	1841
	Animating and Tracking Splines	1854
	Blending Clips	1858
	Interpolating Features	1859
	Refining Distortions	1860
	Filling in Gaps at Edges of Distorted Clips	1866
	Warping Example	1867
	Distort Animation Channels	1868
	Using Distort in Batch	1872
	Saving Preferences	1875
	Saving and Loading Distort Setups	1876
Chapter 64	Warper	1877
	About the Warper	1877
	Accessing the Warper	1878
	Setting Up the Clips	1879
	Creating Meshes	1880
	Modifying a Mesh	1883
	Modifying the Meshes for Live-Action Clips	1891
	Warping	1896
	Morphing	1899
	Setup Options	1905
Chapter 65	Text	1909
	About Text	1909
	Accessing the Text Module	1910
	Processing Text	1913
	Saving and Loading Files	1918
	Adding Text to Clips	1921
	Creating Text Effects	1926
	Loading Logos	1934
	Tabulating Text	1935
	Spell Checking	1936
	Creating Text Rolls and Text Crawls	1937
	Animating Text	1941
	Defining Styles	1947

	Changing Fonts	1950
Chapter 66	Sparks	1957
	About Sparks	1957
	Loading a Sparks Plug-in	1957
	Replacing a Sparks Plug-in	1958
	Using a Sparks Plug-in	1959
	Developing Sparks	1960
	Part 11: Animation and Expressions	1961
Chapter 67	Animation	1963
	About Animation	1963
	Accessing the Channel Editor	1964
	Creating Animations	1971
	Displaying Channels	1985
	Editing Keyframes	2001
	Controlling the Speed of Objects	2022
	Creating Animation Sequences Across Nodes in Batch	2029
Chapter 68	Expressions	2039
	About Expressions	2039
	Working with Expressions in the Channel Editor	2043
	Operator Reference	2049
	Function Reference	2051
	Defining Your Own Functions	2076
	Sample Expression Setups	2078
	Part 12: 3D Compositing with Action	2085
Chapter 69	Action: Basics	2087
	About Action	2087
	Accessing the Action Module	2089
	Using Floating Point Images	2094
	Action Module Overview	2094
	Using the Schematic and Menu Tabs	2100
	Setup and Processing Options	2116
	Saving, Loading, and Importing	2126
Chapter 70	Action: Media	2133
	About Media	2133
	Accessing the Media Menu	2134

	Adding Media	2137
	Viewing Media	2138
	Modifying Media	2141
	Adding Effects to Media	2145
	Accessing the Colour Corrector and the Keyer from Action	2150
	Accessing the Modular Keyer from Action	2152
Chapter 71	Action: DVE Layer Objects	2155
	About DVE Layer Objects	2155
	Adding a DVE Layer Object	2156
	Navigating with DVE Layer Objects	2157
	Modifying DVE Layer Objects	2159
	Replacing a DVE Layer Object's Clip with Another	2163
Chapter 72	Action: Axis	2169
	About Axes	2169
	Manipulating an Object's Axis	2169
	Applying Tracking Data to an Axis	2174
Chapter 73	Action: Surfaces	2177
	About Surfaces	2177
	Adding Surfaces	2178
	Modifying Surfaces	2179
	Editing Tracker Offsets of a Bilinear Surface	2190
	Warping an Extended Bicubic Surface	2190
	Adding a Displacement Map	2198
	Adding Shadows	2202
	Reordering Surfaces	2204
Chapter 74	Action: Sources	2211
	About Source Nodes	2211
	Creating a Matte or Front Source	2212
	Replacing the Front or Matte Clip	2215
	Viewing a Source Node	2217
	Blurring with Source Nodes	2218
	Adding Cameras	2219
Chapter 75	Action: Camera	2221
	About the Camera	2221
	Adding a Camera	2222
	Working with the Frustum	2225
	Importing and Exporting Cameras	2229
	Setting Camera Views	2233

	Modifying the Camera	2236
	Applying Motion Blur	2237
	Applying Fog to the Scene	2240
Chapter 76	Action: 3D Camera Tracking	2243
	About 3D Camera Tracking	2243
	Accessing the 3D Tracker	2243
	Preparing to Track	2244
	Auto 3D Tracking	2245
	Manual 3D Tracking	2254
Chapter 77	Action: 3D Geometry	2273
	About 3D Geometry	2273
	Importing 3D Models	2274
	Working with 3D Geometry	2278
	Adding Textures	2284
	Deforming Models and Surfaces	2296
	Creating 3D Text	2300
	Using Garbage Masks as 3D Geometry	2305
Chapter 78	Action: Lights	2307
	About Lights	2307
	Adding a Light Source	2308
	Applying Selective Lighting	2311
	Modifying Surface Lighting	2313
Chapter 79	Action: The Particle System	2321
	About Action's Particle System	2321
	Generating Particles	2324
	Customizing the Particle Stream	2328
	Exploding Objects and Surfaces	2340
	Manipulating Particles	2343
	Bouncing Particles	2362
	Combining Particle Streams	2366
	Sample Particle Setups	2368
	Part 13: Paint	2371
Chapter 80	Batch Paint	2373
	About Batch Paint	2373
	Accessing Batch Paint	2374
	Using Sources	2376

	Brush Attributes and Attribute Modes	2382
	Painting Brush Strokes	2387
	Using Paint Modes	2392
	Revealing Sources	2396
	Using Blending Modes	2398
	Using the Canvas	2400
	Previewing a Reveal Operation Using a Reference Image	2402
	Saving Setups and Preferences	2404
Chapter 81	Paint: Basics	2405
	About Paint	2405
	Loading Clips into Paint	2406
	Locking and Unlocking the Duration of a Clip	2408
	Using the Mouse	2408
	Displaying a Reference Image	2408
	Using Grids and Guides	2409
	Selecting Colours	2411
	Previewing an Animation	2414
	Painting on Full-Resolution Film Images	2415
	Saving and Restoring the Image	2416
Chapter 82	Painting on the Canvas	2419
	About Canvas Mode	2419
	Selecting a Brush	2420
	Rolling the Image	2421
	Painting with Geometry	2422
Chapter 83	Setting Brush Attributes and Modes	2427
	About Brush Attributes and Modes	2427
	Brush Attributes	2428
	Brush Attribute Modes	2433
	Preferences Affecting Brushes	2435
Chapter 84	Using Filters and Special Effects Media	2437
	Applying Filters	2437
	Using Special Effects Media	2439
Chapter 85	Using Wipe, Fill, and AutoPaint	2451
	Wiping an Image	2451
	Filling an Image	2453
	Using AutoPaint	2457

Chapter 86	Using Mattes in Paint	2467
	About Mattes	2467
	Viewing Mattes	2468
	Creating or Modifying Mattes	2470
	Creating High-Contrast Mattes	2472
Chapter 87	Using Graphics in Paint	2475
	Accessing the Graphics Menu	2475
	Creating Graphics	2476
	Using the Object Tools	2477
	Selecting Objects	2486
	Editing Objects	2488
	Setting the Object Resolution and Display	2490
	Setting the Object Attribute	2492
	Changing the Object's Appearance	2493
	Changing the Size or Position of an Object	2497
	Changing the Shape of an Object	2498
	Converting Graphics to AutoPaint Strokes	2501
	Animating Graphics	2502
	Saving and Restoring Objects	2507
	Tacking Down Objects	2508
Chapter 88	Cutting and Pasting in Paint	2511
	Accessing the CutOut Menu	2511
	Creating a Cutout	2512
	Using the Cutout Commands	2513
	Increasing Editing Speed	2516
	Pasting Cutouts	2517
	Colour Correcting Cutouts	2520
	Animating Cutouts	2521
	Loading and Saving Cutouts	2521
	Preserving Paint Cutouts	2522
Chapter 89	Paint: Setups	2523
	About Paint Setups	2523
	Saving Setups	2524
	Loading Setups	2525
	Deleting Setups	2526
	Creating and Saving Brush Setups	2526
	Creating a Custom Brush	2527
	Using Colour Correction Setups	2534
	Index	2537

Part I: Before You Begin

Part I includes these chapters:

- [Introduction](#) on page 3
- [Compatibility](#) on page 9



Image courtesy of Asylum Visual Effects

Introduction



Topics in this chapter:

- [Welcome to Flame](#) on page 3
- [Notation Conventions](#) on page 4
- [Related Documentation](#) on page 4
- [Contacting Customer Support](#) on page 7

Welcome to Flame

The Autodesk® Flame® online visual effects and compositing system is an Academy-Award®-winning solution that offers superior HD performance for faster compositing, advanced motion graphics and interactive client-driven design. Flame delivers the fast feedback required for client-assisted production and quick turnaround on time-critical projects. Flame provides artists with a powerful 3D compositing environment and industry-leading tools for high-definition multi-format post-production, from video and HDTV to 2K digital cinema. Flame tools include Action, the unique Autodesk 3D visual effects design environment, 3D tracking, Motion Estimation, and the powerful Colour Warper™ and Modular Keyer functions.

Notation Conventions

A number of style conventions are used throughout this guide. These conventions and examples of their use are shown as follows.

Convention	Example
Text that you enter in a command line or shell appears in Courier bold. Press the Enter key after each command.	install rpm -qa
Variable names appear in Courier, enclosed in angle brackets.	<filename>
Feedback from the command line or shell appears in Courier.	limit coredumpsize
Directory names, filenames, URLs, and command line utilities appear in italics.	<i>/usr/discreet</i>

Related Documentation

This release has documentation that helps you install, configure, and use the software, available from your product DVD, on the Autodesk web site, and installed with the product (as PDF files and as an HTML Help system).

For a list of all the documentation available to you, visit <http://www.autodesk.com/flame-documentation>. From this page, you can access the complete documentation library.

You should also refer to your product's release notes for all late-breaking release information.

Accessing Online Help

Included with Flame is an HTML Help system that is displayed in a Web browser. The Help automatically installs on the Flame system and is accessible anywhere within Flame.

The Help is best viewed using Firefox® 2 or Internet Explorer 7.

To start the Help from Flame:

- 1 Start Flame.
- 2 On the bottom-right of the screen, click Help.
You can also click Preferences to display the Preferences menu and click Help.
- 3 A browser launches to display the Help.

TIP Press **Ctrl+=** to open the Help from anywhere in Flame.

Learn how to use the Help by reading the “Using the Help” appendix, available only in the Help.

To copy the Help to another system:

- 1 Copy the *Documentation/help* folder from the product DVD to the new location on another system.
It is recommended to keep the help files locally on any system they are accessed from. Otherwise, browser errors may occur when navigating through the different areas of the Navigation pane. If an error does occur, refresh the browser.
- 2 To start the Help after copying the Help folder, open the *help/index.html* file.

PDF Documentation

The documentation set is also available in PDF (Portable Document Format) for online viewing or printing.

You can access PDF documentation files in one of the following ways:

- From the product DVD on a Windows® or Macintosh® or Linux® workstation
- From the documentation library at <http://www.autodesk.com/flame-documentation>
- Directly from the Preferences menu in the application

Because of some current PDF viewer limitations on Linux workstations, for best results, it is recommended to view PDF documentation on a Windows or Macintosh computer.

Accessing PDF Documentation from the Product DVD

You can use Adobe® Acrobat® Reader™ to view and print PDF documentation files on Windows or Macintosh computers. On Macintosh, you can also use Preview, included in OS X.

PDF documentation is located in the *Documentation* directory at the top level of the Flame DVD.

Copy the PDF files from the documentation directory to a Windows or Macintosh computer.

To view the PDF files on the product DVD from a Linux workstation:

- 1 Go to the *Documentation* directory on the DVD. In a shell, type:
`xpdf <filename>`
and press **Enter**.

Accessing PDF Documentation from Flame

PDF files are installed in the Flame *documentation* directory when you install Flame. You can use commands in a shell to browse to the PDF files. You can also access them directly from the *usr/discreet/<product home>/documentation* directory by selecting the PDF file from the PDF Documentation box in the Preferences menu.

The options in the PDF Documentation box dynamically reflect the contents of the *documentation* directory. You can add any other PDF files to this directory in order to enable access to them from Flame.

To access the PDF files installed on your hard drive:

- 1 Click Preferences to display the Preferences menu.
- 2 Select a document from the PDF Documentation box.

The document opens automatically in Xpdf on Linux workstations.

TIP You can access other PDF documents from here by copying them to the */usr/discreet/<product home>/documentation* directory.

Contacting Customer Support

For a list of contact information for Autodesk Media and Entertainment Customer Support, consult your release notes, or visit <http://www.autodesk.com/support>.

Customer support is also available through your Autodesk reseller. To find a reseller near you, consult the reseller look-up database at <http://www.autodesk.com/resellers>.

Compatibility

2

Topics in this chapter:

- [About Compatibility](#) on page 9
- [Upgrade Compatibility](#) on page 10
- [Backward Compatibility](#) on page 13
- [Compatibility](#) on page 14
- [Compatibility with Previous Versions of Products](#) on page 16
- [Combustion Compatibility](#) on page 16
- [3ds Max Compatibility](#) on page 17

About Compatibility

Autodesk makes every effort to ensure that the compatibility of media and resources is as complete as possible when you perform the following tasks:

- Upgrade your application.
- Share projects between concurrent Autodesk (Inferno®, Flame®, Flint®, Smoke®, Backdraft® Conform) products on the Linux operating system.
- Work collaboratively with compositors using Autodesk Combustion® and with modelers using Autodesk 3ds Max®.

- You can import certain image sequence types (i.e. DPX) or access them with Lustre® using Wiretap®.

The following applications are concurrent versions and are compatible with one another and with Wiretap:

- Inferno 2009
- Flame 2009
- Flint 2009
- Smoke 2009
- Backdraft Conform 2009
- Autodesk Stone® and Wire® 2009
- Burn™ 2009
- Cleaner® XL 1.5.2

Upgrade Compatibility

Consult the following table for information on resource compatibility when upgrading to Flame 2009 from an earlier version.

Pre-2009:	In version 2009:
Projects	Are incompatible. See Upgrade Compatibility—Projects on page 11.
Clip libraries	Are read-only compatible. See Upgrade Compatibility—Clip Libraries on page 11.
Archives	Are read-only compatible. See Upgrade Compatibility—Archives on page 11.
Users	Are incompatible. See Upgrade Compatibility—Users on page 12.
Setups	Are compatible (including most Sparks® setups)

Upgrade Compatibility—Projects

Projects created in earlier versions of Autodesk products do not appear in the Project list in Flame 2009.

Upgrade Compatibility—Clip Libraries

Archive the clips and setups belonging to projects created in earlier versions of Autodesk products and then restore them in the latest version for full read-write access to the project's media. You can also create new projects and then use the Network menu (Wire) to get read-only access to clip libraries belonging to projects created in earlier versions of Autodesk products.

There is metadata associated with clips in Flame 2009 that did not exist in earlier versions of the products. When you transfer material using the Network menu or restore an archive of older material, Flame applies the missing metadata according to default settings. These default settings (for both restoring archives and transferring clips using the Network menu) are defined in the Archiving menu. See [Setting Preferences When Restoring Archives from Previous Versions](#) on page 650.

To transfer clips from an older clip library using the Network menu:

- 1 In Flame 2009, create a project.
- 2 In the Main menu, click Library.
- 3 In the Library menu, click Network.
The network library uses Wire to access the clip libraries created in versions of Flame earlier than 2009. Clip libraries created in versions earlier than 2009 are marked as read-only.
- 4 Select the read-only clip libraries that contain the clips you need and then click EXIT Network.
- 5 Load the clips you need from the old clip libraries and save them to Flame 2009 clip libraries.

Upgrade Compatibility—Archives

Archives created in earlier versions of Autodesk products are read-only compatible.

If you have any soft-imported clips in your archived 2007 libraries, they can be correctly restored into the 2008 release.

Restoring Archives That Do Not Have an Online Table of Contents (OTOC)

If you open an archive created in an earlier version of a product in version 2009, and that archive does not have an OTOC, Flame 2009 will create one, making the archive incompatible with the version of the product that was used to create it.

To open that archive in the earlier version, you must delete the 2009 OTOC first.

Restoring Archives with Editing Clips to an Effects Product

When you restore archives created in a product to a product, all clips are restored without any modifications applied to them.

Restrictions to Archive Compatibility

Read-only compatibility for archives created in earlier versions of Autodesk products is supported provided the archive was created in the following version (or later).

Product	Version
Smoke	1.x
Flint	6.0OCTSE, 6.0IN2, 4.4IR, and 4.0.2 for all other platforms
Flame	4.4IR and 4.5 for all other platforms
Inferno	1.4IR and 1.0 for all other platforms
effect	5.5

Upgrade Compatibility—Users

Users created in earlier versions of Autodesk products are incompatible. You must create a new user profile when you upgrade your application.

Backward Compatibility

In some cases, you may want to restore media and resources in an earlier version of an Autodesk product after having worked in Flame 2009. Backward compatibility is limited, but there are procedures you can perform if necessary.

2009:	In a pre-2009 version:
Projects	Are incompatible. See Backward Compatibility—Projects on page 13.
Clip libraries	Are incompatible.
Archives	Are incompatible. See Backward Compatibility—Archives on page 14.
Users	Are incompatible.
Setups	Are largely compatible. See Backward Compatibility—Setups on page 14.

Backward Compatibility—Projects

When you start an earlier version of an Autodesk product or view the list of projects in the System menu, projects created using Flame 2009 do not appear in the list.

If you want to work with media and resources created in Flame 2009 in an earlier version, you must:

- Recapture or reimport sources captured using Flame 2009.
- Load the setups created in Flame 2009 into the older version, applying them to the appropriate clips. Any settings specific to the new version will be ignored by the older version.
- Reprocess the clips.

Alternatively, you can export the processed clips from Flame 2009 and then import them in the earlier version of the product. In this case, however, the changes you apply in Flame 2009 are irreversible.

Backward Compatibility—Archives

Attempting to open or to append to a Flame 2009 archive using an earlier version of an Autodesk application will cause the material to become unrecoverable.

Backward Compatibility—Setups

Setups that include settings from Flame 2009 not present in earlier versions of products can be loaded, but unrecognized settings are ignored.

Compatibility

If your system or network of systems are running concurrent versions of Autodesk products, media and resource compatibility is almost complete. Editors and effects artists can work in collaboration by sharing projects on the same system or sharing media and resources across multiple systems.

Sharing Projects

No matter which application is used to create a project, its display environment settings, default resolution, and proxy management settings are fully compatible with other Autodesk applications. Even if you create a project in, for example, Flame, its project resource directories will include an *action* directory for saving Action setups should the project be loaded in Smoke.

Even if you create a project in Backdraft Conform, it is fully equipped to be loaded into any other product, without restriction.

When you share projects between products, an independent desktop and EditDesk are maintained. Clips left on the desktop following an Effects session are not available on the EditDesk in a subsequent Finishing session, and vice versa. To ensure that all clips are accessible to all products, make sure you save them to a clip library.

Sharing Clip Libraries

Provided the clip libraries you are sharing were created using concurrent versions of Autodesk products, you have complete read-write access to them.

However, if you have any soft-imported clips in your library (which are read-only by nature), these clips in the 2007 library will appear as a checkerboard in the 2008 release.

Sharing Clips

You can view and render clips created in either Autodesk products. However, if a clip was created using features exclusive to either product, you can only edit those features of the clip in the product in which it was created.

Sharing Setups

Many effects setups can be shared between products. Of these, some can only be shared with restrictions.

Setups Shared without Restrictions

The following setups can be shared between products without restrictions:

- Keyer
- Resize
- Text
- Paint
- Stabilizer
- Filter
- Optics
- Regrain/Degrain
- Colour Correction
- Difference
- Sparks (those for which setups can be saved)

Setups Shared with Restrictions

The Wipe editor does not support explicit coordinates for vertices. Therefore, if you attempt to share this effect, Smoke must convert the wipe to a shape-based animation.

Compatibility with Previous Versions of Products

You can transfer media and resources between previous versions of Autodesk products using the workflow detailed below.

Archives created using earlier versions of products on SGI® systems are read-only compatible on Linux workstations.

Wire Version Compatibility

The 2009 version supports the reading of older projects, libraries, and media going back to version 2007. Remote access (via Wire) to an older version is only permitted if 2009 software is installed on the remote host alongside the older version. A standalone Stone and Wire package is not provided in this release.

For a Linux production system running a 2007 or 2008 release where you do not wish to install 2009 software, or for IRIX® systems (where the 2009 release is not supported), you can use a simple workflow to move media from any 2007 or 2008 clip library to the 2009 system using an intermediary 2007 or 2008 project.

To transfer media from a 2007 or 2008 system to a 2009 system:

- 1 Use Backdraft Conform 2007 or any 2008 application to create a project and a clip library on the 2009 workstation. The project and library will be formatted for 2007 or 2008.
- 2 Use the 2007/2008 application to move clips from the 2007/2008 system over the network into the previously created project on the 2009 system. You can use Background Wire to help free the resources of the 2007/2008 system.
- 3 Use the 2009 application to open the 2007 or 2008 library (the library will be in read-only mode).
- 4 Use Dual View to drag the 2007 or 2008 clips into a 2009 library.

Combustion Compatibility

You can load some setup files from Combustion into Autodesk products and vice-versa, with some minor limitations.

Camera data and models (including textures) originating in 3ds Max can be loaded into the Action () modules. If you modify camera data in Action and

you need to update the corresponding camera data in the 3ds Max file, you can export the camera data in the native 3ds Max format.

Loading Combustion Setups into Products

The following setups created in Combustion 2.0, 2.1, 2.5, and 3.0 can be loaded into products:

- Colour Corrector
- Tracker (can be loaded into the Stabilizer)
- Keyer
- Add Grain and Remove Grain setups (can be loaded into Regrain and Degrain)
- Garbage Mask setups (can be loaded into the Batch GMask node in Effects products)

To copy the setups directly to the Flame project's setup directories, the currently logged-in user must have write access.

Loading Setups into Combustion

The corresponding setups can be loaded into Combustion, with the following limitations:

- Colour Warper settings in Colour Corrector setups are ignored.
- Master Keyer settings in Keyer setups are ignored.
- Garbage Mask setups saved from the Batch GMask node (in Effects products) may not fully translate advanced softness splines.

3ds Max Compatibility

As an alternative to animating a camera's position in Action, you can import camera data from 3ds Max®. In 3ds Max, camera data can be saved as an *.ase* file, which can be imported into products.

Once the *.ase* file is imported, you can edit any of the camera's settings and, if necessary, export the camera data using its native 3ds Max format.

You can also import 3ds Max models into Flame. Textures should be saved with the model so they are visible once the model is imported into the product.

Part 2: Getting Started

Part 2 includes these chapters:

- [Getting Started](#) on page 21
- [The Desktop](#) on page 31
- [Player Essentials](#) on page 93
- [Module Essentials](#) on page 107



Image courtesy of Version 2

Getting Started

3

Topics in this chapter:

- [About This Chapter](#) on page 21
- [Flame Basics](#) on page 22
- [Inputting Media](#) on page 24
- [Working with EDLs](#) on page 25
- [Project and Media Management](#) on page 25
- [Pre-Processing](#) on page 25
- [Editing](#) on page 26
- [Effects](#) on page 27
- [Batch Processing](#) on page 28
- [Managing Your Work Environment](#) on page 28
- [Finishing the Project](#) on page 29

About This Chapter

This chapter presents an overview of Flame and the structure of this guide. The Flame Basics section walks you through a simple session in Flame. This is followed by topics that correspond to the sections in this guide. Each section provides a brief description of its function, and links to the chapters that you will most likely refer to.

The non-linear nature of Flame is designed to accommodate the actual creative process. It is likely you will visit some sections a number of times, and not necessarily in the order presented.

NOTE All descriptions and procedures provided in this chapter assume that your workstation has been set up with factory default Desktop settings.

Flame Basics

This section helps you get started with Flame.

Starting Flame

The first thing you need to do is to start Flame.

To start Flame :

- 1 Log in to the Flame user account.
A password is not required on a new system.
- 2 Double-click the application icon.
The Project Management menu appears. Normally, at the beginning of each session, you select a project and your user profile. See [Managing Projects and Users](#) on page 521. For now, skip this step.
- 3 Click Start.
When the message “Startup Complete” appears, the application has finished loading.
- 4 Tap the pen, click the mouse, or press **Enter** to display the Desktop.

TIP If your pen is not working, press **Shift+T+Insert** to reinitialise the tablet.

About the Desktop

The desktop is your top-level work environment. On the desktop, you can capture clips, organize them in clip libraries, and maintain a current selection of clips that you use for composites and effects. You can play, name, move, copy, and delete clips. You can also use global tools for enabling processes, picking colours, searching for clips, and browsing the filesystem. To learn

more about the desktop and how to use the controls, see [The Desktop](#) on page 31.

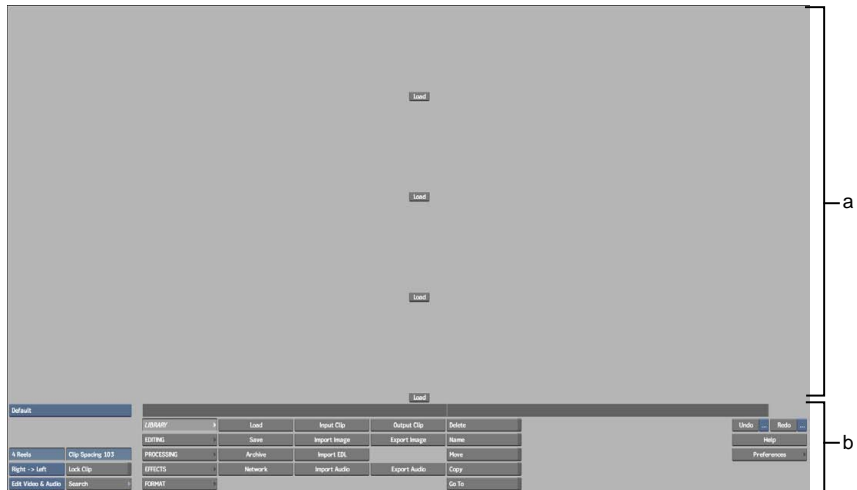

(a) Desktop reels (b) Menu

Accessing Online Help and Documentation

Flame is a feature-rich application that comes with comprehensive online help and documentation. Help contains all the documentation related to Flame.

To start Help from Flame:

- 1 To access help, on the lower-right side of the Desktop, click Help.

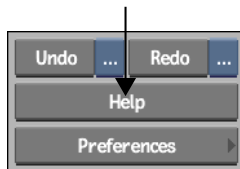

Alternately, press **Ctrl+=** to access help from anywhere in Flame.

TIP You may want to start by reading the *Using the Help* section. This is only available in the on line help.

- 2 To access online documentation, click Preferences to display the Preferences menu, and then click PDF Documentation.

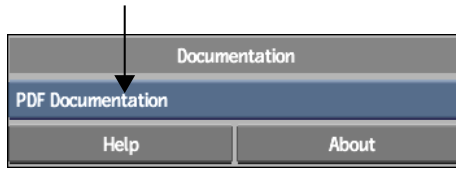

Exiting Flame

At any time, you can choose to exit Flame. Clips, along with the effects and edits that you applied, are automatically and continually saved throughout your Flame session, so there is no need to save before exiting.

To exit Flame:

- 1 On the lower-right side of the Desktop, click Preferences.

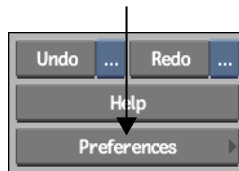

- 2 In the Preferences menu, at the bottom-right corner, click the Exit Flame button.
The button changes to a Confirm button.
- 3 Click Confirm.

Inputting Media

Before you can begin any work in Flame, you must acquire media. There are a number of ways to do this in Flame.

You can input media by:

- Capturing video and audio from tape. See [Clip Input/Output Using a VTR](#) on page 143.

- Capturing 2K film resolution images through an SMPTE-292 HD-SDI signal from an HSDL-compliant device. See [Clip Input/Output Using HSDL Devices](#) on page 187.
- Importing image files, audio files, and streaming media from the filesystem. See [Importing Media Files](#) on page 193.

Working with EDLs

If your production environment includes some post-production applications and tools, it is very likely that you are using EDLs to transfer media and data between them.

Besides standard EDLs, you can work with telecine log files and AAF, FCP XML, and OMF[®] files. You can import, export, edit, and create EDLs, and capture and import media using EDLs. All of this is described in the Working with EDLs section, which begins with [About EDL Files](#) on page 317.

Timecode and keycode are essential tools for working with EDLs, or for conform and recapture. Timecode and keycode can be imported with the media, assigned, changed, burned-in, or removed. See [Timecode and Keycode](#) on page 403.

Project and Media Management

Once you acquire media and resources, you need to address project and media management issues, such as managing the project and user resources, and saving and sorting clips in clip libraries.

Managing projects and media consists of:

- Creating a project for each job that you work on, as well as creating a user profile for each person working on your system. See [Managing Projects and Users](#) on page 521.
- Creating clip libraries where you can save clips on the framestore. See [Clip Libraries](#) on page 555.

Pre-Processing

With your media and resources organized and ready for creative work, you are ready to perform preparatory image processing. Pre-processing is especially

useful when dealing with media originating from different formats, including film. You can pre-process clips to simplify your work, making your editing, compositing, or visual effects work easier to do.

Pre-processing includes:

- Resizing clips to manage media originating from different formats. See [Resize](#) on page 663.
- Managing pulldown removal and insertion, and monitoring 24 fps and 30 fps timecodes, for projects originating on film. See [2:3 Pulldown](#) on page 703.
- Changing the field dominance of clips, if you need to mix different interlaced video formats. This is important if you are working with video sources originating from NTSC and PAL, or NTSC and HDTV, in the same project. See [Video Field Management](#) on page 719.
- Applying LUTs to film-based clips, as well as importing, loading, and creating LUTs. See [Colour Management with LUTs](#) on page 729.
- Removing or adding film grain to accommodate matte creation or image-processing tasks. See [Adding and Removing Film Grain](#) on page 773.

Editing

The Editing section explains how to perform various editing functions in Flame, from making the most basic cuts and splices, creating transitions such as dissolves and wipes, to creating composites through vertical editing.

Basic editing concepts used in Flame are described, as are some editing interface elements, and instructions for using tools that will come in handy during the editing process.

You can perform editing operations on the desktop, on the timeline in the Player, and on the timeline in Batch.

The Editing section begins with [Editing Essentials](#) on page 927.

Using soft effects, you can create many compositing effects directly on the timeline and view the result without processing. See [Soft Effects](#) on page 1111.

When working with audio, you can perform many of the same editing operations that you use to edit video, such as cutting, trimming, and adding dissolves. A comprehensive set of audio effects tools is available in the timeline, in Batch, and AudioDesk for mixing and mastering your audio. See [Audio](#) on page 1195.

Effects

At any time during your work session, you can use the effects tools to perform any creative or image-processing work. Flame provides an array of sophisticated visual effects and compositing tools.

Visual effects include:

- Applying basic image processes. See [Processing and Formatting Commands](#) on page 1425.
- Colour-correcting and colour-matching clips using the Colour Corrector. See [Colour Corrector](#) on page 1451.
- Creating artistic colour effects and performing advanced colour correction using the Colour Warper. See [Colour Warper](#) on page 1483.
- Performing basic keying functions. See [Keyer](#) on page 1545.
- Using advanced keying functions using the Modular Keyer. You can select from an array of tools to pull a key and to colour correct a clip selectively. See [Modular Keyer](#) on page 1603.
- Using 3D Keyer to pull a key, perform advanced colour analysis of areas in a clip, and then refine the key with increased accuracy. See [3D Keyer](#) on page 1661.
- Using garbage masks, supported by the Keyer, 3D Keyer, and the Modular Keyer. See [Garbage Masks](#) on page 1707.
- Creating a composite while controlling cropping, softness, and camera, and applying glow effects. See [Compositor and Optics](#) on page 1763.
- Removing motion jitter ,or unwanted camera movement, and tracking reference points in your clips. See [Tracking and Stabilizing](#) on page 1781.
- Warping images and morphing from one image to another. See [Warper](#) on page 1877 and [Distort](#) on page 1821.
- Using a high-powered, 3D, multilayer compositing tool for creating complex visual effects. You can use Action to animate clips in 3D and add camera, lighting, and shadow effects. The Action section begins with [Action: Basics](#) on page 2087.
- Retouching clips or creating graphics, textures, and displacement sources using the comprehensive Paint tools. The Paint section begins with [Paint: Basics](#) on page 2405.

Animating Effects

You use the Channel Editor to create animations—almost all modules link directly to the Channel Editor.

In Batch, the Channel Editor provides universal access to all channels in all nodes.

You can add animation keyframes to all animatable parameters, or channels, in a scene. See [Animation](#) on page 1963.

You can also apply expressions to animation channels to modify parameters according to dynamic feedback in the scene. See [Expressions](#) on page 2039.

Batch Processing

Much of what you can do with separate effects modules and operations can also be done in a single integrated environment called Batch. Working in the Batch module, you can assemble a processing pipeline by linking clips and nodes that provide access to operations and integrated modules. For an introduction to Batch, see [Batch Overview](#) on page 1259.

In Batch, you can:

- Assemble processing pipelines for complex composites. See [Batch Processing](#) on page 1283.
- Add image processing and visual effects nodes. See [Batch: Node Reference](#) on page 1329.
- Apply Batch FX to one or more timeline segments. See [Batch FX](#) on page 1375.

Managing Your Work Environment

This section contains information about additional options that you can use to customize and enhance your Flame work environment.

This includes:

- Using the Preferences menu to set up your work environment. Preferences can be global or shared between two or more areas. See [Setting Preferences](#) on page 827.

- Saving and loading effects setup files and preferences. See [Saving Setups and Preferences](#) on page 799.
- Tracking and updating operations that you have applied to a clip or clip segment. See [Clip History](#) on page 807.
- Using the Hot Key Editor to manage hot keys (keyboard shortcuts). The Hot Key Editor allows you to view listings of the current hot keys, modify existing hot keys, or create new ones. See [Managing Hot Keys](#) on page 863.
- Installing additional fonts for use in Action, Paint, and Text. See [Installing Fonts](#) on page 873.
- Using the volume integrity check, finding and deleting invalid frames, and applying other disk testing and command line utilities. [Utilities](#) on page 877.
- Using one of several start-up options to specify a particular setup or to enable a customized configuration. See [Command Line Start-up and Exit Options](#) on page 919.

Finishing the Project

Once you are finished working on your project, you can process the results, export or output any finished media to files or to tape, and back up or archive any relevant project media and data.

When finishing the project you can:

- Use the Unlink and Relink tools to perform any conforming operation separating the media of a clip from its metadata, reformatting the metadata of an unlinked clip to another resolution, recapturing the associated media, and relinking the metadata to the newly captured media. See [Unlinking and Relinking Media and Clips](#) on page 269.
- Process a clip to create new media that incorporates any soft effects, timewarps, and dissolves. You can publish a clip to create media that resides outside of Autodesk storage (in a shared storage device or area) and a soft-imported clip that references that media. See [Processing and Publishing](#) on page 291.
- Save your edits using an EDL or OMF file. See [Exporting EDLs](#) on page 393, or [Importing and Exporting OMF Files](#) on page 499.

- Export clips, image sequences, audio files, and video files. See [Exporting Media Files](#) on page 233.
- Output clips to tape. See [Clip Input/Output Using a VTR](#) on page 143.
- Output 2K film resolution images to an HSDL-compliant device. See [Clip Input/Output Using HSDL Devices](#) on page 187.
- Archive the project. Once a project is complete and the final clips have been output, it is a good idea to archive its clip libraries, setups, and EDLs. Archive the project to tape or to file, and generate online tables of contents to make browsing and restoring archives easier. See [Archiving](#) on page 603.

The Desktop

4

Topics in this chapter:

- [About the Desktop](#) on page 31
- [Selecting Clips to Apply a Desktop Command](#) on page 43
- [Selecting Clips to Load Them into a Module](#) on page 43
- [Using the Desktop Module Editor](#) on page 45
- [Working with Clips on the Desktop](#) on page 45
- [Locking and Unlocking Reels](#) on page 55
- [Locking Clips to Prevent Changes](#) on page 56
- [Naming Clips, Reels, and Desktops](#) on page 58
- [Moving, Copying, and Deleting Clips on the Desktop](#) on page 60
- [Undoing and Redoing Operations](#) on page 68
- [Calculating Values for Numeric Fields](#) on page 68
- [Picking Colours](#) on page 71
- [Searching the Desktop](#) on page 77
- [Navigating the Filesystem](#) on page 82

About the Desktop

On the desktop, you work with the clips from which you create processed results for your project. You can play, name, move, copy, and delete clips, as well as use global tools for enabling processes, picking colours, searching for clips, and browsing the filesystem.

After selecting a project and user on start-up, the desktop appears. The desktop is your in-session work area. You capture clips to the desktop, organize them in clip libraries, and then maintain a desktop selection of clips that you need for the composites and effects you are working on at each step.

From the desktop, you can:

- Create virtual clips such as colour bars, coloured frames, and noise.
- Capture clips from tape or import image sequences from the filesystem.
- Edit clips using gestural editing techniques, and apply timewarps.
- Save clips to and load clips from clip libraries. That is a timewarp.
- Apply format processes to clips such as Resize, Interlace, Filed Merge, and Change Timecode/Keycode.
- Execute image processing commands such as Monochrome, Flip, Burn-In Timecode, and Logical Operations.
- Load clips into modules, gaining access to complex image processing and compositing tools such as Paint, the Modular Keyer, the Colour Corrector, Action (a 3D compositing environment supporting unlimited composite layers), and Batch (a batch processing environment providing integrated, uncommitted access to almost all the above image processing commands and modules).
- Output clips to tape or export images sequences and QuickTime® movies.
- Create archives to file or tape.

NOTE Descriptions and procedures in this chapter assume default desktop settings. The desktop can be customized and the settings can be saved with user preferences. See [Setting Preferences](#) on page 827.

Desktop Layout

The desktop appears on start-up, and it is your top-level work environment in each session. Once you start the application and select a project and user with which you want to work, the application initialises. When initialisation is complete, the message “Startup complete” appears in the message bar. Tap the pen, click the mouse, or press Enter. Five buttons comprising the Main menu appear in the lower-left corner of the screen. This is the desktop.

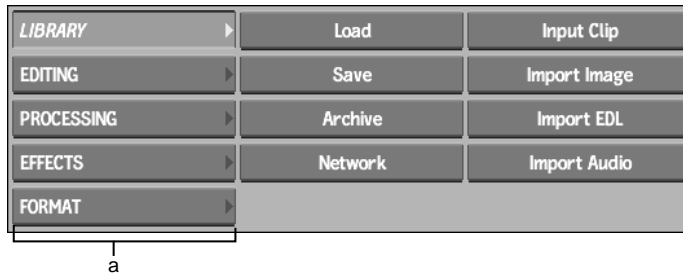

(a) Main menu

The Main menu buttons are described as follows.

Library (or press 1) Opens the Library menu. The Library menu provides management and archiving functions for clips and image files. You can use the network library to access clip libraries in other projects on the local system or from remote systems. You can also transfer clips to and from an external recording device (such as VTRs) or the filesystem.

Editing (or press 2) Opens the Editing menu. The Editing menu provides commands for editing and assembling clips. You can cut, splice, reverse, and copy clips. You can also perform mixes, dissolves, crossfades, change the timing of a clip, and access the EDL menu for importing EDLs.

Processing (or press 3) Opens the Processing menu. The Processing menu provides image processing commands that are applied to frames in a clip. You can also change the colours of a clip and perform colour corrections.

Effects (or press 4) Opens the Effects menu. The Effects menu contains modules for compositing and adding special effects to clips.

Format (or press 5) Opens the Format menu. The Format menu contains video and film setup commands. There are commands for changing the field dominance and for interlacing, deinterlacing, and merging the fields in a clip.

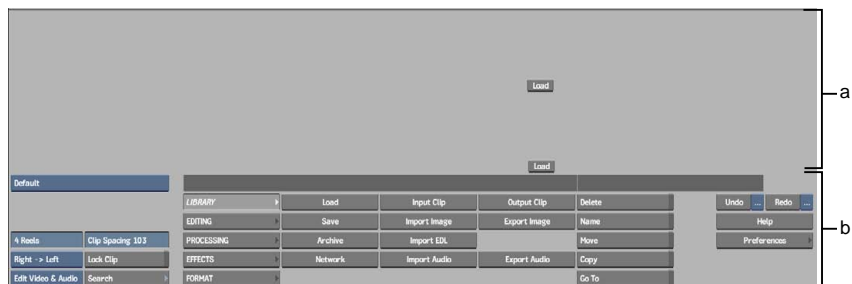

(a) Desktop reels (b) Menu

The menu contains Reel display options, controls for the currently selected menu, Undo/Redo buttons (and lists for multiple undo), and the Help and Preferences buttons.

The desktop contains reels to which you capture, create, and load reels. If you are starting a new project, the reels are empty.

Desktop Files

Desktop files are saved continuously during a session. When you exit and then restart Flame with a project, its previous desktop reappears, even if you did not save the clips on the desktop to a clip library. See [Autosave](#) on page 839.

Using the Pen

In most cases, you work with a pen-and-tablet input device instead of a mouse. Here are some tips on using the pen:

- To move the cursor over the screen without activating any controls, hold the tip of the pen over the tablet without touching it.
- To click a button or select an item, touch the pen to the tablet.
- To drag an item, touch the pen to the tablet and drag. Release when you are done.
- If you see instructions where you have the option to **Ctrl-click**, press the button on the side of the pen as you click. For example, to use X-copy functionality, drag the selection and then press the button as you touch the tablet to set the destination for the copied text.





Working with the pen takes a little time to get used to, but it is an ideal input device for working with Flame. You can set pen-and-tablet preferences in Flame. See [Pointer Preferences](#) on page 830.

For more information on using the pen-and-tablet, consult the documentation provided by the manufacturer.

NOTE If you cannot use the pen-and-tablet, use the mouse to move the cursor. To switch from the tablet to the mouse while running Flame, press **Shift+M+Insert**. To switch back to the pen-and-tablet, press **Shift+T+Insert**. To initialise Flame to work with the mouse, see [Start-up Options](#) on page 920.

Buttons

The most common user interface element is a button, and buttons come in a few varieties.

Button Type	Appearance	Description
Menu toggle		Opens a menu, usually to the right of the button. In other cases, a menu toggle button (with a light blue triangle) shows and hides the menu associated with the button without changing the previous menu selection. The Animation menu toggle button in all modules is an example.
Menu radio		Opens a menu, usually to the right of the button. A menu radio button (with a dark grey triangle) takes focus from another menu in a given set. The Main menu buttons on the desktop are an example.
Action		Initiates an action. The Undo and Redo buttons on the desktop are examples.
Command/Module		Applies a desktop image process or loads clips into a module. The right edge of these buttons is dark grey. Clicking a command button changes the cursor to an arrow so you can select the clip(s) to which you want to apply the command. See Selecting Clips to Apply a Desktop Command on page 43. Clicking a module button changes the cursor to an arrow so you can select the clip(s) that you want to load into the module. See Selecting Clips to Load Them into a Module on page 43.
Toggle		Enables and disables a function. Toggle buttons are recessed when enabled, raised when disabled. The right edge of these buttons is light blue when enabled, dark blue when disabled.

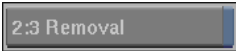
Button Type	Appearance	Description
With LEDs		Some buttons have LEDs to indicate states. For example, the In and Out buttons in the Player that you use to mark in and out points have an LED that lights up when an in or out point has been marked on the current clip. LEDs indicate different states in each case, and these states are documented with the relevant procedure.
Inactive		In some cases, another process in progress will deactivate a button or a set of buttons, meaning you cannot use the button temporarily. In this case, the text on the button is darker and clicking the button has no effect.

Boxes

Boxes contain two or more options. Boxes are dark blue.

To select an option, press the box to make its options appear and then drag the cursor over the option that you want to select. When you release the cursor, the box displays the current selection.

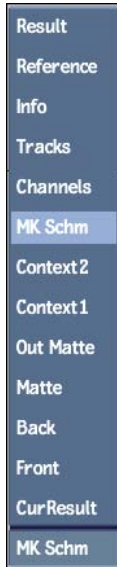



If the box has only two options, it behaves like a toggle button: it does not expand to show the other option; rather, it switches to the other option immediately.

Fields

Use fields to enter numeric values and text. Fields are recessed, light blue boxes.

Numeric Fields

The following descriptions presume you have numeric indicators enabled (the default setting) in your preferences. See [User Interface Preferences](#) on page 831. A horizontal bar appears on the lower edge of numeric fields when the Numeric Fields button is enabled.

Numeric Field Type	Appearance	Description
Unrestricted		A numeric field with an unrestricted value range accepts any numeric value.
Restricted		A numeric field that accept values within a preset range. The small white numeric indic-

Numeric Field Type	Appearance	Description
		ator shows the current value relative to the range for the field.

With numeric indicators enabled, fields provide the following feedback:

- If a numeric field is set to its default value, the horizontal bar running along the lower edge of the field is blue.
- If a numeric field is set to another value, the horizontal bar running along the lower edge of the field is black.
- If the numeric field accepts a restricted range of values, the current value is indicated relative to the range by a white marker along the horizontal bar that runs along the lower edge of the field.

You can enter values into numeric fields gesturally or using the on-screen calculator.

TIP To reset a field to its default value at any time, **Ctrl**-click the field.

To enter a value in a numeric field using the calculator:

- 1 Click the numeric field.
The calculator appears.
- 2 Use the calculator to enter a value and then press **Enter**.

TIP You can use the numeric keypad keys on your keyboard to operate the calculator. See [Calculating Values for Numeric Fields](#) on page 68.

To enter a value in a numeric field using the calculator:

- 1 Drag over the field to change its value:
 - Drag left to decrease the value.
 - Drag right to increase the value.

TIP Numeric fields respond to tablet pressure; the harder you press while dragging, the more quickly the value changes.

- 2 When you reach the value you need, release the cursor.

Text Fields

Text fields are primarily used for naming purposes, for example, to name a node in a Batch processing setup, or to name a setup file when you save it using the file browser. You can also use X-copy functionality to enter text into a field.



To enter text in a field:

- 1 Click the text field to activate it.
- 2 Press **Esc** to delete the current contents.
- 3 Type the new text using the keyboard.

TIP You can use the **up** and **down arrow** keys on your workstation keyboard to retrieve previously typed character strings.

- 4 Press **Enter**.

To enter text in a field, you also have the option of using the on-screen keyboard. Set this preference in the User Interface section of the Preferences menu. When On-screen Keyboard is enabled, you enter text in the on-screen keyboard that appears when you click a field. For certain commands, for example, naming reels and desktops, the on-screen keyboard automatically appears.

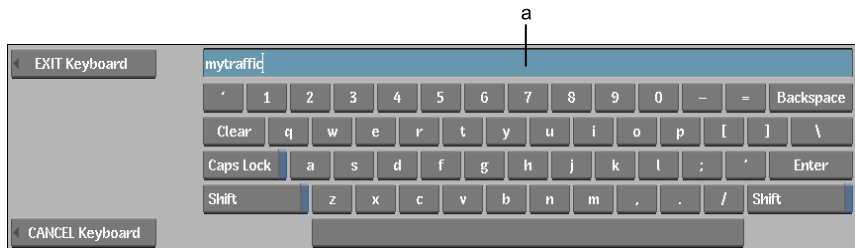

(a) Keyboard field

Use the on-screen keyboard as you would use your workstation's keyboard. When you press a key on the screen, the character appears in the Keyboard field. To save text from the on-screen keyboard, click Enter or click Exit Keyboard. You can also press **Enter** on the workstation's keyboard. To return

to the previous menu from the on-screen keyboard without saving your changes, click Cancel Keyboard.

To enter text into a field using X-copy functionality:

- 1 With the cursor over the Flame interface, press **Alt+F3** to send Flame to the background.
- 2 In, for example, a **gedit** window, drag a text selection of the text you want to copy.
- 3 With the cursor over the Flame interface, press **Alt+F1** to bring Flame to the foreground.
- 4 Click the text field to activate it. Do not make a text selection in the field.
- 5 Press **Esc** to clear the current text in the field.
- 6 Click the text field again, pressing the pen button at the same time as you click to enter the text selection that you made in step 2.

TIP You can use this technique to copy large text files for text rolls and text crawls into a layer in the Text module. See [Creating Text Rolls and Text Crawls](#) on page 1937.

Colour Pots

Use colour pots to set colours associated with functions and objects. For example:

- Set the colour of a coloured frame that you create on the desktop or in Batch.
- Set the display colour of splines and tangent handles in the GMask menu.
- Set the colour suppression target colour when keying.



(a) Colour pot

When you click a colour pot, the colour picker appears. Use the colour picker to set a colour by adjusting channel values, selecting a colour stored in colour pots or from a mixing palette, or by sampling from a frame in a clip. See [Picking Colours](#) on page 71.

Accessing System Messages

The message bar that appears on the desktop and in most input/output and import/export modules provides feedback from the system.

You can also access a log of the system messages at any time during the current session. The next time you start a session, the message history is cleared and the system begins logging messages for that session.

To prevent too many messages from being displayed, the log identifies identical messages instead of listing each one separately. It also identifies messages that are similar. For example, the first and last frames of a processing operation are listed as two separate messages yet all the frames processed in-between are treated as similar and are grouped into one processing message.

To access the message history for the current session:

- 1 From anywhere in the application, press **Ctrl+Alt+F7**.

The Message History window appears showing a list of all messages logged for the current session. Identical and similar messages are identified in the Repeat column.

# ▾	Time	Message	Source	Repeated
1	Thu Mar 23 15:37:46 2006	Processing: Burn In – frame 10 of 10 – 00:00.	message	
2		Processing: ...	message	Similar messages: 4
3	Thu Mar 23 15:37:45 2006	Processing: Burn In – frame 0 of 10 – 00:00.	message	

a

(a) Four similar processing messages indicate processed frames between the first and last frames, which are listed as separate processing messages.

You can set the number of values saved, reset the message history, and do specific searches. For information on these settings, see [Miscellaneous Preferences](#) on page 835.

Cursors

The default cursor is a yellow cross.



However, the cursor changes under some conditions:

- If you are processing a clip, the cursor becomes a grey icon, indicating that you cannot interact with Flame until processing is complete.
- If you click a desktop command or module button, the cursor changes to an arrow, and its colour indicates the action you are expected to take.

Use:	To select:
Red arrow	The front clip.
Green arrow	The back clip.
Blue arrow	The matte clip.
White arrow	The destination reel for the processed result.

Other cursors will appear, such as schematic editing cursors in Action and Batch. These other cursors are explained in the procedures in which they occur.

Selecting Clips to Apply a Desktop Command

Desktop commands apply image processes to clips on the desktop. When you click a desktop command button, the cursor changes, indicating the clip selection requirements for the command you want to apply.

To apply a desktop command:

- 1 Click the desktop command button in, for example, the Processing menu. The cursor becomes a red arrow.
- 2 The red arrow indicates that you should select:
 - The front clip, if the command performs a compositing process, such as Quick Composite (see [Quick Compositing](#) on page 1777).
 - The first input clip, if the command is a mix operation, such as a Multiply logical operation (see [Using Logical Operations](#) on page 1433).

To select the front or first input clip on the desktop reels, click its upper-left corner.

- 3 If the cursor becomes a green arrow, select the back clip or second input clip. Otherwise, continue with the next step.
- 4 If the cursor becomes a blue cursor, select the matte clip (the blue cursor only appears with compositing commands and modules). Otherwise, continue with the next step.
- 5 Once all the input clips for the command are selected, the cursor becomes a white arrow. The white arrow indicates that you are ready to select the destination desktop reel for the processed result clip. Click any desktop reel.

The processed clip appears on the destination reel that you selected, with a red outline. The most recently processed clip on the desktop always has a red outline.

Selecting Clips to Load Them into a Module

When you enter modules from the desktop, you select the input clips that you want to work with. Each module allows for different variations of input

clips, but the loading process is the same: front first, back second, and matte third (as applicable). Exceptions to this are:

- The Paint and Text modules, where you have the option of entering without clips.
- The Batch module, where you enter without clips and then input clips to the Batch desktop using Batch nodes.

To load clips into a module:

- 1 Click the module button in, for example, the Effects menu.
The cursor becomes a red arrow.
- 2 The red arrow indicates that you should select the front clip.
To select the front clip on the desktop reels, click its upper-left corner.
- 3 If the cursor becomes a green arrow, select the back clip. Otherwise, continue with the next step.
- 4 If the cursor becomes a blue cursor, select the matte clip. Otherwise, continue with the next step.
- 5 Once all the input clips for the module are selected, the cursor becomes a white arrow. The white arrow indicates that you are ready to select the destination desktop reel for the processed result clip. Click any desktop reel.

When you process clips from the module, they appear on the destination reel that you selected, with a red outline. The most recently processed clip on the desktop always has a red outline.

To enter a module with the same clips as the previous session:

- 1 Click the module button in, for example, the Effects menu.
An “S” appears on the right edge of the button.



- 2 With the arrow cursor, click the “S”.
The module opens with the clips from the previous session. The most recent settings are also restored.

Using the Desktop Module Editor

The Desktop Module Editor option lets you preview a command before it is applied to the clip. The option is only available for certain commands, and is indicated by an “E” that appears on the button prior to selecting the clip destination.



See [Previewing Results for Processing Commands](#) on page 1427, and [Previewing Results for Format Commands](#) on page 1446.

Working with Clips on the Desktop

Clips on the desktop are collapsible, low-resolution versions of the entire clip. Depending on the preferences you set, clip information can appear as an overlay. You can scrub desktop clips, entire reels, or jump to a specific frame in a clip based on its frame number or timecode.

By default, clips scrub left-to-right, although you can change playback direction or orient reels vertically, as described in the next section. Procedures in this document assume the default left-to-right settings.

Setting Display Options for Reels

Use the controls on the left side of the desktop menu to set desktop reel display options. These can also be set in the Preferences menu.

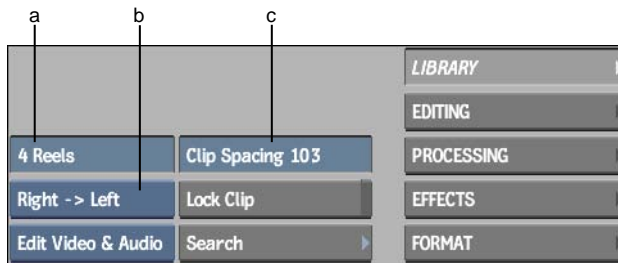

(a) Reels field (b) Reel Direction box (c) Clip Spacing

Reels field Use to change the number of reels that are visible on the desktop. You can choose between four and eight reels. The reels automatically scale to fit the desktop as you change the number of reels.

NOTE If you reduce the number of reels that are visible on the desktop when there are clips on all reels, the clips remain on the hidden reels. If you save the desktop, all reels including the hidden ones are saved.

Reel Direction box Use to change the orientation (horizontal or vertical) and direction of the reels on the desktop. The direction of the reels determines which way the frame numbers increment in a clip. The following options are available:

- Right → Left
 - Left → Right
 - Bottom → Top
 - Top → Bottom
-

NOTE The default orientation and direction is Right → Left.

Clip Spacing Set the amount of space between clips in reels on the desktop.

Clip Information

Thumbnails, or proxies for each frame in the clip, display information about the clip and frame. Frame numbers, record timecode, and/or keycode appear in the upper-left corner. The name and duration of the clip appears in the lower-left corner. If the clip has a resolution that does not match the project resolution, timecode or frame numbers that appear on the clip are light blue.

For more information on the display of keycode on clip proxies, see [Displaying Timecode and Keycode](#) on page 405.



(a) Frame number and selection area (b) Name of clip and number of frames in the clip

Soft-import clips have an icon in the lower-right corner that indicates the file format of the source images. See [About Soft-Import and Proxies](#) on page 199.



(a) Soft-import icon

Clips that have a clip history associated with them have an “H” in the upper-right corner. See [Clip History](#) on page 807.



(a) Clip History icon

You can also set preferences to display source and/or record timecode, frame rate (24 fps, 25 fps, 30 fps, 50 fps, or 60 fps), and resolution (image size in

pixels, bit depth, and aspect ratio). For information on setting clip display preferences, see [General Preferences](#) on page 836.

Collapsing and Expanding Clips

You can expand and collapse clips on the desktop. Expanding clips makes it easier to see the progression of a clip from frame-to-frame. When clips are collapsed, you can fit more on the visible part of the desktop reel.

A collapsed clip is a stack of frames.



An expanded clip is a strip of contiguous frames.

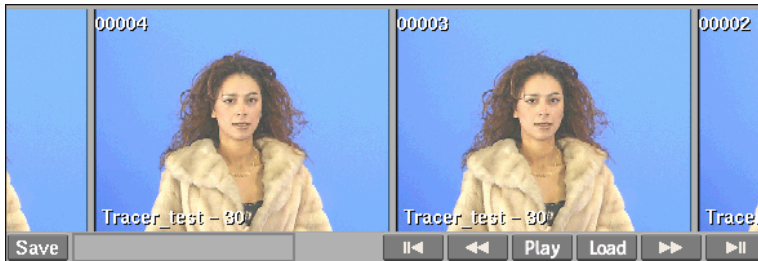

To collapse and then expand a clip:

- 1 Move the cursor over any frame of an expanded clip.
- 2 Press **C**.
- 3 To expand the clip, move the cursor over the collapsed clip and press **C**.

To collapse and then expand all clips on a reel:

- 1 Position the cursor over a grey area between clips on a reel.
- 2 Press **C**.

- 3 To expand all clips on a reel, repeat the previous two steps.

To collapse and then expand all clips on the desktop:

- 1 Position the cursor in the menu.
- 2 Press C.
- 3 To expand all clips on the desktop, repeat the previous two steps.

Scrubbing a Clip

You can scrub a clip by dragging left or right on the upper-left corner of a frame. A yellow indicator along the upper edge of the frame indicates the relative position in the clip of the currently displayed frame.



(a) Yellow indicator

When you scrub through an expanded clip and then release the cursor at a particular frame, the clip slides along the reel so the frame displayed when you finish scrubbing is under the cursor.

Scrubbing a Reel

Desktop reels have a set of scrubbing controls that you can use to scrub forward and backward, jump to the previous or next clip on the reel, load clips to the reel from a clip library, or load clips into the Player for full-resolution playback.



Click: **To:**



Go to the first frame of the clip over the reel's playback controls. Clicking a second time advances to the last frame of the previous clip.



Scrub the reel backward.



Load the clip over the playback controls into the Player for full-resolution playback. See [Playing Clips in the Player](#) on page 94.



Load a clip from the clip library currently selected in the Clip Library box. This is similar to clicking Load in the Library menu and selecting the destination reel, except you can load a clip directly to a reel even when the Library menu is not showing.



Scrub the reel forward.



Go to the last frame of the clip currently over the reel's playback controls. Clicking a second time advances to the first frame of the next clip.

You can also drag over the hot spots to perform these reel scrubbing operations gesturally. In this case, dragging the cursor works much like turning a jog wheel on a VTR control panel: scrub speed and direction respond interactively to cursor movements.

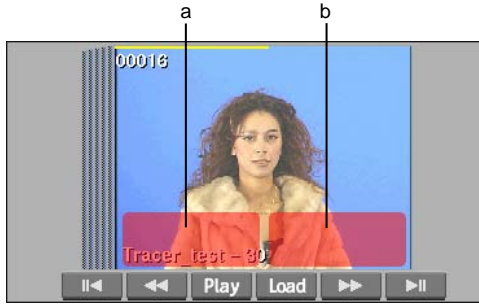

(a) Scroll-forward hot spot (b) Scroll-backward hot spot

To:	Drag:
Scrub forward	Over the scroll-forward hot spot and to the left.
Scrub backward	Over the scroll-forward hot spot and to the right.

Lastly, you can scrub a clip by clicking the middle of a frame and dragging left or right. In this case, you move the clip the same amount as you move the cursor.

Going to a Frame in a Clip

To go to a specific frame in a clip, use the Go To button, or the Go To hot key.

To go to a frame in a clip using the Go To button:

- 1 Click Go To.



The cursor changes to a purple arrow, and the Go To menu appears in the area beside the Go To button.

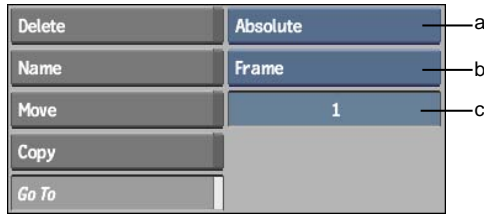

(a) Go To Method box (b) Go To Mode box (c) Go To Target field

2 From the Go To Method box, select an option.

Select:	To:
Absolute	Go to the destination frame or timecode entered in the Go To Target field.
Relative	Move the number of frames—backward (negative value) or forward (positive value)—entered in the Go To Target field.

3 From the Go To Mode box, select an option.

Select:	To:
Source Timecode	Enter a Go To target using source timecode.
Frame	Enter a Go To target using frame numbers.

4 In the Go To Target field, enter a target value.

5 Using the purple arrow cursor, select the clip containing the frame to which you want to go.

The frame you specified appears under the cursor. If you selected Relative from the Go To Method box, click again to repeat the Go To operation.

6 Click any grey space in the menu to deactivate the Go To operation.

To go to a frame in a clip using the Go To hot key:

1 Place the cursor over the clip containing the frame to which you want to go.

2 Press **G**.

The numeric keypad appears.

- 3 Enter the number of the frame that you want to find.
The clip advances to the specified frame number.

TIP Entering frames or source timecode depends on the desktop display preferences you have set during the session. See [General Preferences](#) on page 836.

Adding Notes to Clips

You can add notes to clips on the desktop using the built-in notepad, which is a simple text editor. Each entry is annotated with the creation date and time of the note and the user who entered it, so you can use the clip notepad as an informal discussion area for clips in progress.

Notes are saved as part of the clip's metadata, so the information is preserved if you transfer the clip to another workstation using Wire. When you copy a clip on the desktop that contains notes, the notes are copied too. When you archive a clip, its notes are saved with the archived clip.

To add notes to a clip's notepad:

- 1 Put the cursor over a clip on the desktop and press **V**.
- 2 Enter your notes in the notepad that appears.

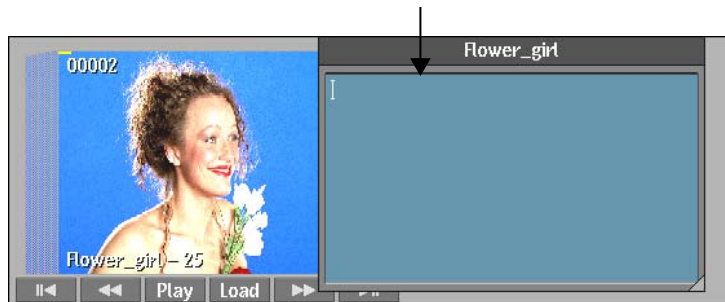

- 3 Click anywhere outside the notepad to close it.
An icon with the letter “N” appears on the clip, indicating that it has a note.

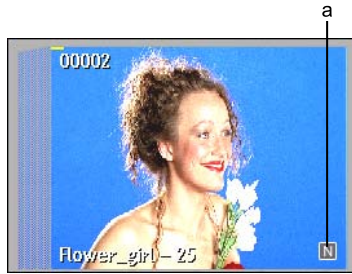

(a) Note icon

To edit a clip's notepad:

- 1 Put the cursor over a clip on the desktop that has a note and press **V**.
The notepad appears with an annotation that tracks the creation date and time and the user who added each note.

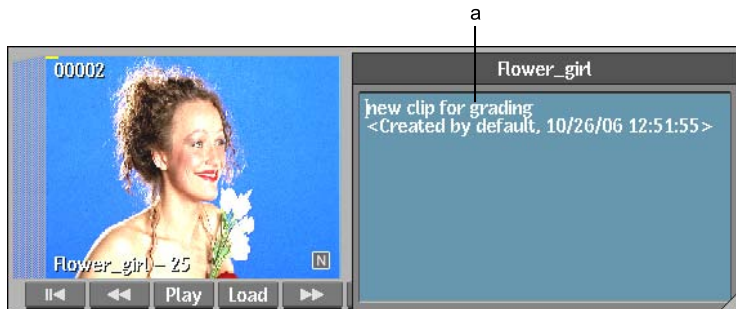

(a) Annotation

- 2 Place the cursor after the last line and then enter your notes.

TIP When you enter a note, the annotation is always added as the last line. To ensure an easily trackable sequence of notes, add new notes at the end.

- 3 Click anywhere outside the notepad to close it.

To delete a clip's notepad:

- 1 Put the cursor over a clip on the desktop that has a note and press **V**.
- 2 Select all text in the notepad and then delete it.

- 3 Click anywhere outside the notepad to close it.
The “N” icon disappears, indicating the note has been deleted.

To resize a notepad:

- 1 Click the lower-right corner of the notepad and drag.
A red outline of the notepad appears as you drag.

Locking and Unlocking Reels

You can lock reels to constrain their scrubbing behaviour to a selected clip. If you lock a clip on two different reels, you scrub them in sync. This is helpful when you want to scrub different versions of a clip simultaneously.

To lock a reel to a selected clip:

- 1 Hold the cursor over the frame of the clip on a reel and press **L**.
A light blue border appears around the selected clip, and the clip—if it was collapsed—expands to show all frames.
- 2 Scrub the reel.
Only the selected clip is scrubbed.
- 3 To unlock a reel, hold the cursor anywhere over the reel that you want to unlock and press **L**.

NOTE Clicking a command or module button also unlocks all reels.

To scrub clips on different reels in sync:







- 1 Expand the clip on an unlocked reel that you want to scrub.
- 2 Line up a reference frame of the clip on the locked reel over the Play button in the reel playback controls.
- 3 Press **L** to lock the reel to that clip.
- 4 Line up the corresponding reference frame of the expanded clip on another unlocked reel with the frame you chose in step 2.
Although the clips scrub in sync, you can offset their alignment by positioning them relative to each other prior to locking the reels.
- 5 Hold the cursor over the corresponding reference frame and press **L**.

A light blue border appears around the selected clip.

- 6 Scrub either reel.
The selected clips scrub in sync.
- 7 Lock other reels to add clips to the set.
- 8 To unlock a reel, hold the cursor anywhere over the reel that you want to unlock and press **L**.

To navigate clips on locked reels:

- 1 Use the following reel controls.

Do this:	To:
Click 	Go to the next end (to the left) of the clips in the locked set.
Alt-click 	Go to the next transition (to the left) of the clips in the locked set.
Click 	Play the locked set backward.
Click 	Play the locked set forward.
Alt-click 	Go to the next transition (to the right) of the clips in the locked set.
Click 	Go to the next end (to the right) of the clips in the locked set.
Press left arrow	Frame step backward by the specified number of frames (10 by default). See Reels on page 851.
Press right arrow	Frame step forward by the specified number of frames (10 by default). See Reels on page 851.

Locking Clips to Prevent Changes

You can lock clips, reels, or desktops to prevent changes to them. Locking a clip prevents it from being deleted or edited (including unprocessed timewarps).

You can save locked clips to a library, but their locked status is not maintained. You can also bypass a lock to delete a clip if necessary.

The procedures in this topic are not related to locking reels to selected clips.

NOTE If you use the Force Render command, it will affect all selected clips even locked clips. See [Force Rendering Clips](#) on page 966.

To lock a clip on the desktop:

- 1 On the desktop, click Lock Clip.

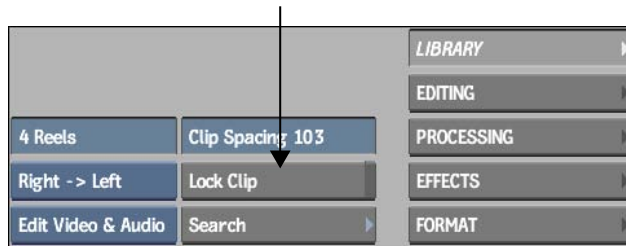

- 2 Select to lock a clip, all clips on a reel, or the entire desktop from the Lock option box that appears.
- 3 Select the clip that you want to lock.
The selected clip, all clips on the same reel as the selected clip, or all clips on the desktop are locked. The clip's timecode or frame number display turns red, indicating a locked clip. If you try to edit or delete a locked clip, a message appears in the message bar indicating that the operation is not permitted.

To unlock a clip:

- 1 On the desktop, click Lock Clip.
- 2 Select an option from the Lock option box.
- 3 Select the locked clip, and confirm.
The timecode or frame number display turns white. To bypass the need to confirm, Alt+click the red frame number.

To delete a locked clip:

- 1 Hold down the **Alt** key.

- 2 Delete the clip as described in [Deleting Clips](#) on page 66.

Naming Clips, Reels, and Desktops

To help keep track of clips in-progress, it is a good idea to give them meaningful names. You can name clips, reels, and desktops.

Naming Clips

You can name clips using the Name button or the Name hot key.

NOTE Naming a clip does not save it to a clip library. To save a clip, see [Saving to Clip Libraries](#) on page 561.

To name a clip using the Name button:

- 1 From the desktop, click Name.

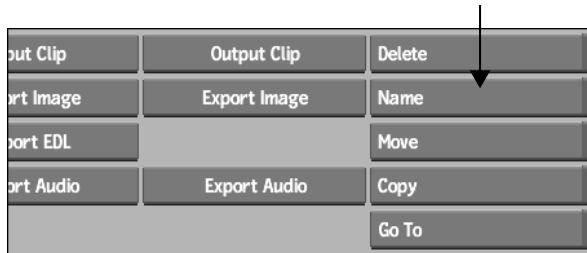

- 2 With the red arrow cursor, select the clip that you want to name.
- 3 To clear the current contents of the Name field, press **Esc**.
- 4 Enter a name for the clip and then press **Enter**.
The new name appears on the clip proxy, provided this display option is enabled. See [General Preferences](#) on page 836.

To name a clip using the Name hot key:

- 1 Hold the cursor over the clip that you want to rename.
- 2 Press **N**.
The on-screen keyboard appears.

- 3 Type a name for the clip and then press **Enter**.

Naming Reels

Place clips into groups on a reel and then name the reel to identify the group.

NOTE Naming a reel does not save it to a clip library. To save a reel, see [Saving to Clip Libraries](#) on page 561.

To name a reel:

- 1 Click the Reel Name field for the reel that you want to name.



The on-screen keyboard appears.

- 2 To clear the current contents of the field, press **Esc**.
- 3 Enter a name for the reel and then press **Enter**.

Naming Desktops

Name a desktop to provide a description of the current selection of clips on all reels.

NOTE Naming a desktop does not save it to a clip library. To save a desktop, see [Saving to Clip Libraries](#) on page 561.

To name a desktop:

- 1 Click the Save Desktop Name field.

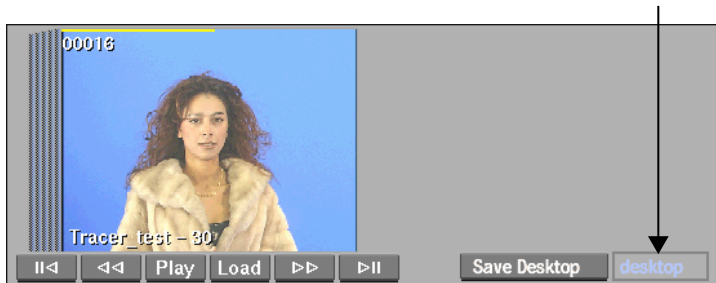

The on-screen keyboard appears.

- 2 To clear the current contents of the field, press **Esc**.
- 3 Enter a name for the desktop and then press **Enter**.

Moving, Copying, and Deleting Clips on the Desktop

You input, import, and load clips to destination reels on the desktop. Once clips are on the desktop, you can move, copy, and delete them. Note the following about these functions:

- Copying clips on the desktop does not duplicate frames on the framestore.
- Deleting clips from the desktop does not remove them from the framestore, provided they were previously saved to a clip library.
- All clip moving, copying, and deleting operations are tracked in the Undo and Redo boxes.

For gestural techniques to work, the Drag & Drop option must be selected in the Preferences menu. See [Desktop Preferences](#) on page 848.

Moving Clips

Move clips from reel to reel using the Move button or gestural techniques. You can also move a single frame or a range of frames by extracting them from a clip, move the audio tracks associated with a clip, or move all clips on a reel.

To move a clip or all clips on a reel using the Move button:

- 1 From the desktop, click Move.

- 2 From the Move Mode box, select an option.

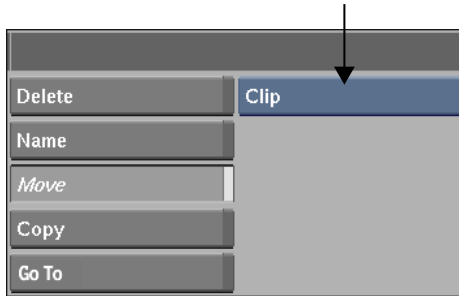

Select:	To move:
Clip	A single clip.
Reel	All clips on a reel.

- 3 With the red arrow cursor, select the clip or reel that you want to move.
- 4 With the white arrow cursor, select the reel to which you want to move the clip or reel.
The clip is moved to the destination reel.

To move clips gesturally:

- 1 Drag a clip from one reel to a destination reel.

To move a single frame gesturally:

- 1 **Ctrl**-drag a frame from one clip to a destination reel.

TIP Move clips by clicking in the middle of a frame and then dragging upward or downward. If you drag from the edges of frames, you risk cutting the clip. If you drag to the left or right, you simply scrub the reel.

To move a single frame using the Move button:

- 1 From the desktop, click Move.
- 2 From the Move Mode box, select Frame.

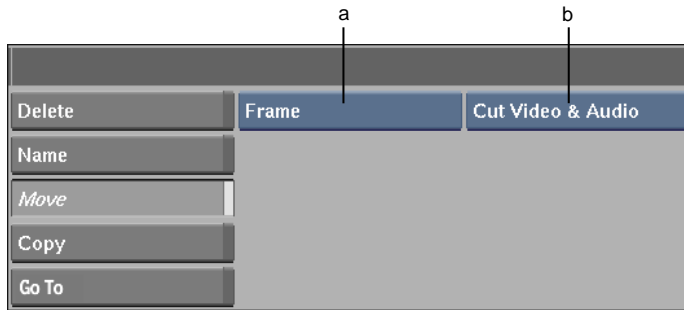

(a) Move Mode box (b) Range Mode box

- 3 From the Range Mode box, select an option.

Select:	To extract:
Cut Audio & Video	The range of video frames with its corresponding audio range.
Cut Video	The range of video frames but attach the entire audio track.

- 4 With the red arrow cursor, select the frame that you want to move.
- 5 With the white arrow cursor, select the reel to which you want to move the frame.
The frame is removed from the source clip to the destination reel.

To move a range of frames using the Move button:

- 1 From the desktop, click Move.
- 2 From the Move Mode box, select Range.
The Range Mode box appears.

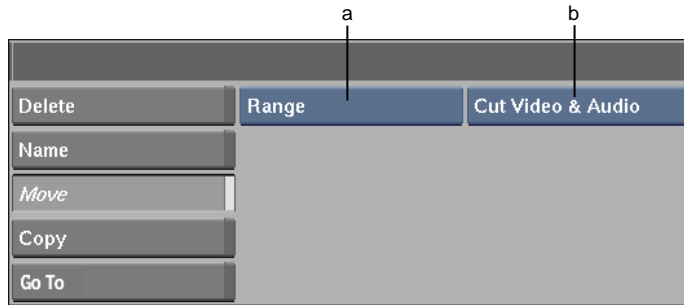

(a) Move Mode box (b) Range Mode box

- 3 From the Range Mode box, select an option.

Select:	To extract:
Cut Audio & Video	The range of video frames with its corresponding audio range.
Cut Video	The range of video frames but attach the entire audio track.

- 4 With the red arrow cursor, select the first frame in the range that you want to move.
- 5 With the green arrow cursor, select the second frame in the range that you want to move.
- 6 With the white arrow cursor, select the reel to which you want to move the range.
The range is removed from the source clip to the destination reel.

To move an audio track from one clip to another:

- 1 From the desktop, click Move.
- 2 From the Move Mode box, select Audio.

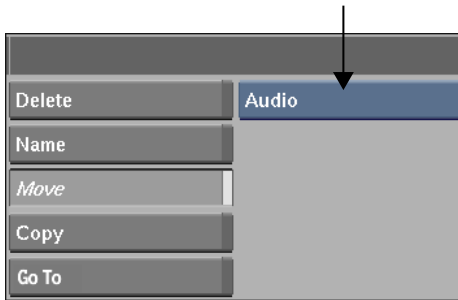

- 3 With the red arrow cursor, select the clip to which the audio that you want to move is associated.
- 4 With the white arrow cursor, select the clip to which you want to move the audio.

Copying Clips

Copy clips on the desktop using the Copy button or gestural techniques. You can also copy a single frame or a range of frames, copy the audio tracks associated with a clip, copy timecode, copy keycode, or copy all clips on a reel.

To copy a clip or all clips on a reel using the Copy button:

- 1 From the desktop, click Copy.
- 2 From the Copy Mode box, select an option.

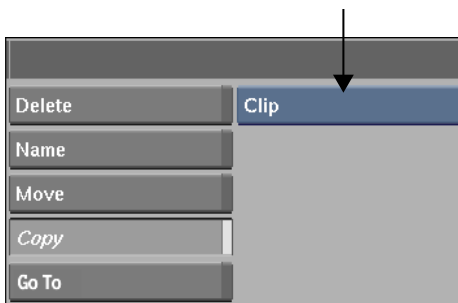

Select:	To copy:
Clip	A single clip.

Select:	To copy:
Reel	All clips on a reel.

- 3 With the red arrow cursor, select the clip or reel that you want to copy.
- 4 With the white arrow cursor, click the destination reel for the copied clip or reel.

To copy clips gesturally:

- 1 While pressing **Spacebar**, drag a clip to another reel. The copy appears as a partially transparent clip until you drop it.

TIP You can adjust proxy transparency. See [Desktop Proxies](#) on page 850.

To copy a single frame gesturally:

- 1 While pressing **Shift+spacebar**, drag a clip to another reel. The copy appears as a partially transparent clip until you drop it.

To copy a source clip from an edited clip gesturally:

- 1 While pressing **Shift**, drag a frame belonging to the source clip that you want to copy to another reel. The copy appears as a partially transparent clip until you drop it.

To copy a range of frames, or to copy frames with or without audio:

- 1 Follow the instructions for the comparable Move button procedures. See [Moving Clips](#) on page 60.

TIP Copy clips by clicking in the middle of a frame and then dragging upward or downward. If you drag from the edges of frames, you risk cutting the clip. If you drag to the left or right, you simply scrub the reel.

To copy the timecode from one clip to another:

- 1 From the desktop, click Copy.
- 2 From the Copy Mode box, select Timecode.

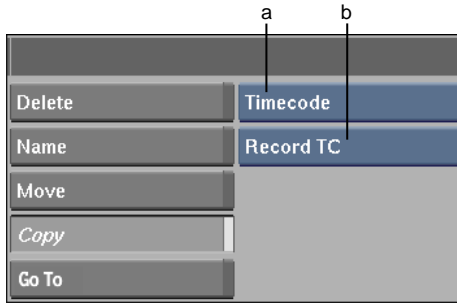

(a) Copy Mode box (b) Timecode Mode box

- From the Timecode Mode box, select an option.

Select:	To copy:
Record TC	The record timecode.
Source TC	The source timecode.

- With the red arrow cursor, select the clip with the timecode that you want to copy.
- With the white arrow cursor, select the clip to which you want to copy the timecode.
The timecode is copied to the clip.

Deleting Clips

Delete clips from the desktop using the Delete button or gestural techniques. You can also delete a single frame or a range of frames, delete the audio tracks associated with a clip, or delete all clips on a reel.

To delete clips using the Delete button:

- From the desktop, click Delete.
- From the Delete Mode box, select an option.

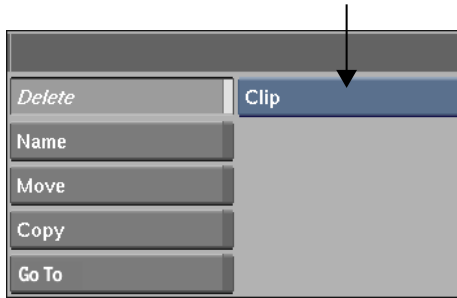

Select:	To delete:
Clip	A single clip.
Reel	All clips on a reel.

- 3 With the red arrow cursor, select the clip or reel that you want to delete. The clip or reel is deleted from the desktop.

TIP If necessary, click Undo to restore the clip.

To delete clips gesturally:

- 1 Drag a clip from its reel to the bottom of the menu.
- 2 When the recycle cursor appears, release the clip to delete it.

To delete a range of frames, or to delete frames with or without audio:

- 1 Follow the instructions for the comparable Move button procedures. See [Moving Clips](#) on page 60.

Deleting Desktops

Delete all clips on the desktop using the Delete button.

To delete all clips on the desktop:

- 1 From the desktop, click the Delete button.
- 2 From the Delete Mode box, select Desktop and then Confirm (or press **Enter**).

When the desktop is deleted, its name is cleared from the Desktop Name field.

Undoing and Redoing Operations

You can undo most commands performed on the desktop using the Undo/Redo controls in the lower right of the screen.

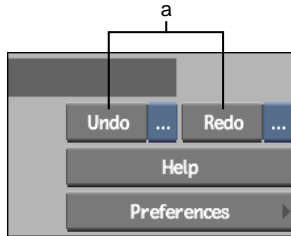

(a) Undo and Redo buttons

Click Undo to undo the most recent operation.

Use the box on the right of the Undo button to perform a multiple undo by selecting an operation in the Undo history. The selected operation, and all commands appearing under it, are undone.

Click Redo to redo the most recent operation undone by clicking Undo.

Use the box on the right of the Redo button to perform a multiple redo by selecting an operation in the Redo history. The selected operation, and all those appearing it, are redone.

You can set the levels of Undo and clear the Undo buffer. See [Undo](#) on page 840.

NOTE Use undo controls in modules to undo operations performed in them. Multiple levels of undo are supported in Batch, the Modular Keyer, and Action. In other modules, a single undo can be performed.

Calculating Values for Numeric Fields

The calculator appears when you click a numeric field. Use it to calculate integer values or timecode. The timecode calculator appears only when you click a field that accepts timecode values and when you display preferences that are set to use timecode, and not frame numbers.

By default, the calculator appears over the field you clicked to open it. You can move it to another location by dragging the grey bar along its upper edge. You can also set calculator preferences to open the calculator at other locations. See [User Interface Preferences](#) on page 831.

There is another type of calculator, the keycode calculator, used for inputting keycode. The keycode calculator appears when you click a Keycode field. See [About the Keycode Calculator](#) on page 410.

Calculating Numbers

The calculator that you use with fields that accept numeric values works like a standard calculator, with options to add, subtract, multiply, and divide.

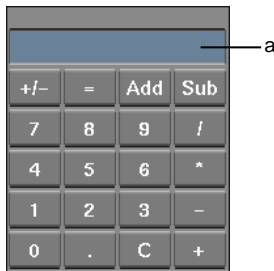

(a) Result field

To calculate integers:

- 1 Click a numeric field accepting integers to open the calculator.
- 2 Use the integer and operation buttons to determine the value that you want to apply to the numeric field.
- 3 To add the value in the calculator to the current value in the numeric field, click Add.
- 4 To subtract the value in the calculator from the current value in the numeric field, click Sub.
- 5 To close the calculator without applying further changes to the value in the numeric field, click anywhere outside the calculator.
- 6 To enter the current value in the calculator—replacing the previous value—click the Result field in the calculator or press **Enter**.
The calculator closes.

TIP You can use the keys on the numeric keypad section of your keyboard to operate the calculator.

Calculating Timecode

The calculator that you use with fields that accept timecode and frame number values works like a standard calculator, but provides additional tools for calculating timecode and frame number values.

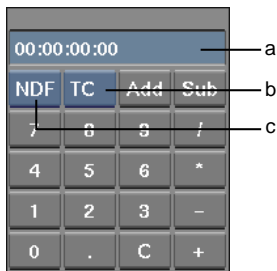

(a) Result field (b) Calculation Mode box (c) Drop Frame box

The calculator opens with the timecode mode (24 fps, 25 fps, 30 fps, 50 fps, and 60 fps) that applies to the default project resolution or the clip to which you are applying the value.

To calculate timecode:

- 1 Click a numeric field accepting timecode and frame numbers to open the calculator.
- 2 Use the integer and operation buttons to determine the value that you want to apply to the numeric field.

TIP To enter two zeros for a timecode unit block, press . (period).

- 3 To switch between frame numbers and timecode, select an option from the Calculation Mode box.

Select:	To calculate:
FRM	Values using frame numbers.
TC	Values using timecode.

TIP You can calculate a value in frames and apply the value to timecode. The value is converted automatically.

- 4 To switch between drop frame and non-drop frame timecode modes, select an option from the Drop Frame box.

Select:	To calculate:
DF	Values using drop frame timecode.
NDF	Values using non-drop frame timecode.

TIP This box only appears when drop frame and non-drop frame modes are valid options.

- 5 To add the value in the calculator to the current value in the field, click Add.
- 6 To subtract the value in the calculator from the current value in the field, click Sub.
- 7 To close the calculator without applying further changes to the value in the field, click anywhere outside the calculator.
- 8 To enter the current value in the calculator—replacing the previous value—click the Result field in the calculator or press **Enter**.
The calculator closes.

TIP You can use the keys on the numeric keypad section of your keyboard to operate the calculator. Colons, semicolons, and other timecode notation marks are added automatically.

Picking Colours

When you click a colour pot, the colour picker appears. You can then set the colour pot to use the colour you need. Using the colour picker, you can pick colours by:

- Setting colour model channel values
- Sampling pixels in a clip
- Selecting a colour pot

■ Mixing colours on a palette

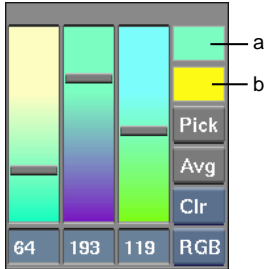

(a) Current Colour pot (b) Reference Colour pot

By default, the colour picker appears over the colour pot you clicked to open it. Once it is open, you can move it to another location by dragging the grey bar along its upper edge. You can also set colour picker preferences to open the colour picker at other locations (the colour picker inherits the same preferences as those you set for the calculator). See [User Interface Preferences](#) on page 831.

To cancel colour picking at any time, click anywhere outside the colour picker.

Picking Colours by Setting Colour Model Channel Values

You can pick colours by adjusting colour model channel sliders. You can also enter channel values directly into the fields below each slider.

The Mode box and Colour Model box settings, and channel value units (percentages or bit-values) are saved on a per-user basis, at the end of each session.

To pick colours by setting colour model channel values:

- 1 Click a colour pot to open the colour picker.
The Current Colour pot and Reference Colour pot both display the incoming colour.
- 2 From the Mode box, select Clr or Clr% to view the colour model channel sliders.

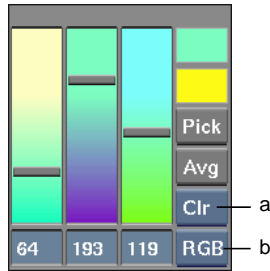

(a) Mode box (b) Colour Model box

Select: To:

Clr Enter values using a range based on bit depth (0-255 for 8-bit, 0-4095 for 12-bit). Enter values from 0-255.

Clr% Enter values using a percentage floating point value, ranging from 0-100%.

- 3 From the Colour Model box, select the colour model you want to work with.

Select: To set colours using the:

RGB Red, green, and blue channels.

HLS Hue, luma, and saturation channels.

YUV Luma (Y) and chroma (U, V) channels.

- 4 Adjust the sliders, or enter the values in the fields for each slider.
As you adjust the sliders, the colour in the Current Colour pot changes to reflect the current colour. You can compare the current colour to the incoming colour in the Reference Colour pot.
- 5 To apply the selected colour, click the Current Colour pot.

Sampling Colours in a Clip

Sampling pixels in a clip is often the best way of setting the colour you need. For example, to suppress colour spill when keying a clip, the best way to set the colour suppression target is to zoom in on the result clip and then sample the colour spill directly.

You can sample single pixels, take an average along a path, or take an average from inside a selection box.

To sample a pixel:

- 1 Click a colour pot to open the colour picker.
The Current Colour pot and Reference Colour pot both display the incoming colour.
- 2 Click Pick.

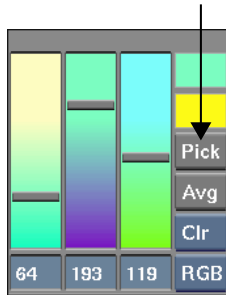

- 3 Click in the Player or image window to sample a pixel in the clip.
The sampled colour appears in the Current Colour pot.
- 4 To apply the selected colour, click the Current Colour pot.

TIP From any colour pot, **Shift**-click to enter Pick mode. Clicking while dragging the Pick icon over an image will display its RGB values. Click again to transfer the colour to the colour pot.

To sample an average colour along a path:

- 1 Click a colour pot to open the colour picker.
The Current Colour pot and Reference Colour pot both display the incoming colour.
- 2 Click Avg.

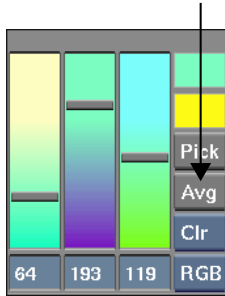

- 3 Drag a path in the Player or image window to take an average from the clip.
The sampled colour appears in the Current Colour pot.
- 4 To apply the selected colour, click the Current Colour pot.

TIP To sample from paths in different parts of the clip, press **Alt** when finishing the first path-sample and then begin another path elsewhere. Repeat if necessary. Release the cursor without pressing **Alt** to apply the cumulative average to the Current Colour pot.

To sample an average inside a selection box:

- 1 Click a colour pot to open the colour picker.
The Current Colour pot and Reference Colour pot both display the incoming colour.
- 2 Click Avg.
- 3 **Ctrl**-drag a path in the Player or image window to take an average from the clip.
The sampled colour appears in the Current Colour pot.
- 4 To apply the selected colour, click the Current Colour pot.

Selecting a Colour from the Colour Pots

Select from 1 of 15 preset colours in the colour pots. You can also store custom colours in the colour pots.

To select a colour from the colour pots:

- 1 Click a colour pot to open the colour picker.
The Current Colour pot and Reference Colour pot both display the incoming colour.
- 2 From the Mode box, select Pot.

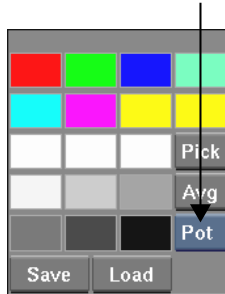

- 3 Click one of the colour pots to apply the colour to the Current Colour pot.
- 4 To apply the selected colour, click the Current Colour pot.

To customize the colour pots:

- 1 Click a colour pot to open the colour picker.
The Current Colour pot and Reference Colour pot both display the incoming colour.
- 2 Use the colour picker to apply the colour that you want to store to the Current Colour pot.
- 3 From the Mode box, select Pot.
- 4 Click and hold on the pot in which to store the selected colour.

When you select Pot from the Mode box, Save and Load buttons appear at the bottom of the colour picker to save custom sets of colour pots. See [Saving Setups and Preferences](#) on page 799.

Mixing Colours Using the Colour Palette

You can use the colour picker to mix colours on a palette.

To mix colours:

- 1 Click a colour pot to open the colour picker.
The Current Colour pot and Reference Colour pot both display the incoming colour.
- 2 From the Mode box, select Paint.

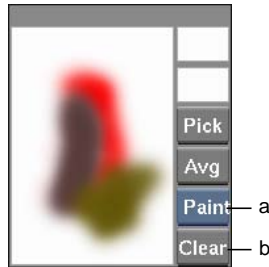

(a) Mode box (b) Clear button

- 3 Use the colour picker to apply the colour that you want to store to the Current Colour pot.
- 4 Drag over the mixing palette to add a swatch of the current colour.
- 5 Repeat the steps 3 and 4 to add other colours to the palette.
Colour mixing occurs as more colours are added and they blend.
- 6 To clear the mixing area at any time, click Clear.
- 7 To select a colour from the mixing palette, click Pick and then click in the mixing area.
The mixed colour appears in the Current Colour pot.
- 8 To apply the selected colour, click the Current Colour pot.

Searching the Desktop

Use Search tools to locate clips on the desktop quickly. You can search for clips or locate matching frames on the desktop. When you search for clips, you set attribute options and then search either the desktop or all clip libraries.

Search tools to locate clips in clip libraries also appear in the Clip Library menu. See [Searching for Clips](#) on page 582.

TIP If you want to search for source clips that you previously used to create a soft edit, use the Match Source command from the Editing menu. See [Matching Soft Clips with Their Source Clips](#) on page 956.

Searching for Clips from the Desktop

You can use the Search menu to find a clip on the desktop or to load clips from clip libraries associated with the current project that meet the search criteria to the desktop.

To search for a clip:

- 1 From the desktop, click Search.

The Search menu appears.

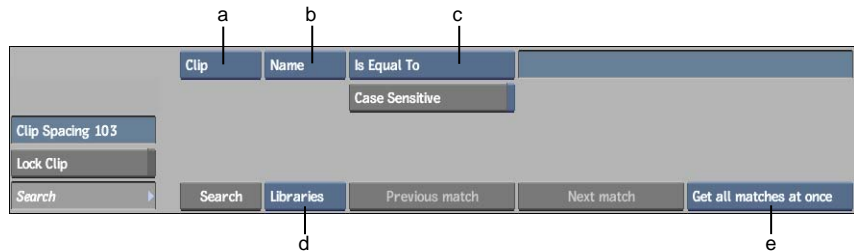

(a) Search Mode box (b) Search Attribute box (c) Argument option box (d) Search Area box (e) Search Result Mode box

- 2 From the Search Mode box, select Clip.
- 3 From the Search Result Mode box, select an option.

Select:	To:
Get All Matches At Once	Display all matches at once.
Get Matches One By One	Display the total number of matches, and then provide the means of viewing them one-by-one using the Previous Match and Next Match buttons.

- 4 From the Search Area box, select an option.

Select:	To search:
Desktop	The desktop.

Select:	To search:
Libraries	Clip libraries associated with the current project.

- 5 Set the Search Criteria: select options from the Search Attribute and Argument boxes, and supply the necessary search information.

Attribute option:	Searches for:	Using one of these arguments:
Comment	A comment	Is; Is Not; Contains; Does Not Contain; Is Less Than; Is Greater Than; Matches Pattern
Tape	A tape name or number	Is; Is Not; Contains; Does Not Contain; Is Less Than; Is Greater Than; Matches Pattern
Archive Date	Archive dates	Is Equal To; Is Not Equal To; Is Earlier Than; Is Later Than; Never; Whenever
Clip History	Clip histories	Contains; Does Not Contain; Intermediates; Intermediates+Src; Sources When you search using the Intermediates, Intermediates+Src, and Sources options, you are prompted to select a clip that has a clip history. The intermediates and sources matched by the search are those associated with the selected clip.
Soft Import	Soft imports	Contains; Does Not Contain
Soft Edit	Soft edits	Contains; Does Not Contain
Mixed Res	Soft or hard resizes	Contains; Does Not Contain
Resolution	A clip resolution	Is Equal To; Is Not Equal To; Is Less Than; Is Greater Than; Is Less Or Equal; Is Greater Or Equal When you search using the Resolution option, other controls appear so you can specify resolution attributes such as width, height, bit depth, aspect ratio, and scan mode. You can also choose to ignore any of these attributes.
Audio	Audio	Contains; Does Not Contain

Attribute option:	Searches for:	Using one of these arguments:
Duration	A clip duration	Is Greater Than; Is Less Than; Is Equal To; Is Not Equal To
Date	A date	Is Earlier Than; Is Later Than; Is Equal To; Is Not Equal To
RecTC	A record timecode	Is Greater Than; Is Less Than; Is Equal To; Is Not Equal To; Contains; Does Not Contain
SrcTC	A source timecode	Is Greater Than; Is Less Than; Is Equal To; Is Not Equal To; Contains; Does Not Contain
Name	A clip name	Is; Is Not; Contains; Does Not Contain; Is Less Than; Is Greater Than; Matches Pattern

- 6 To restrict the search to strings that match in case as well as content, enable Case Sensitive.
- 7 In the Search menu, click Search.

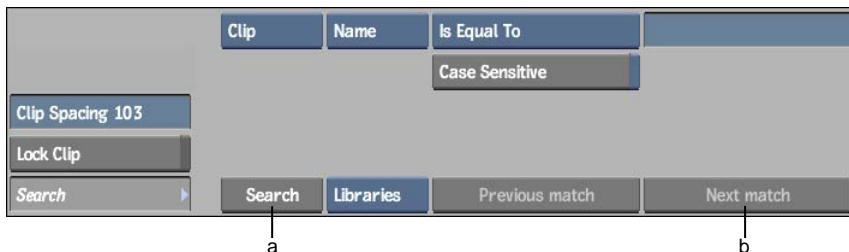

(a) Search button (b) Next match button

Results are displayed depending on the option you selected in step 3:

- If you selected Get Matches One By One, the first match is centred on its reel.
- If you selected Get All Matches At Once, all matches appear on the same reel.

The message bar reports which reel the match resides on and how many matches were found. If no matches are found, the message “No matches” appears in the message bar.

- 8 If you selected Get Matches One By One, click Next Match to continue checking additional matches.

Searching the Desktop for Matching Frames

Search for matching frames in clips on the desktop.

To search the desktop for matching frames:

- 1 On the desktop, click Search to display the Search menu.

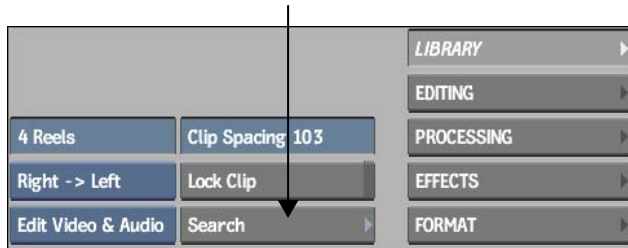

- 2 From the Search Mode box, select Frame.

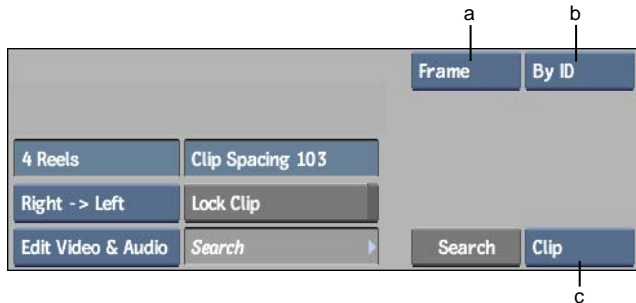

(a) Search Mode box (b) Match Attributes box (c) Range box

- 3 From the Range box, select an option.

Select:	To search:
Clip	A selected clip for matching frames.
Reel	All clips on a selected reel for matching frames.

- 4 From the Match Attributes box, select an option.

Select:	To:
By Pixels	Match frames, pixel by pixel. This can be helpful if you know that the matching frame occurs in another processed result or in a clip originating from a different capture session.
By ID	Locate matching frame identification numbers. Searching for matching clip IDs is faster than searching for matching frames pixel by pixel.

- 5 Click Search in the lower left of the Search menu.
- 6 With the red arrow cursor, select the frame to match.
The cursor changes to a green arrow if you are searching a clip, and to a white arrow if you are searching a reel.
- 7 Select the clip or reel on the desktop in which you want to search for a match.
If the search is successful, the matching frame aligns to the centre of its reel, and the following message appears in the message bar:
“Matches frame <n> in clip <x> centred on reel <y>”
where <n> is the frame number, <x> is the clip name, and <y> is the reel number on which the frame was found.
- 8 The reels on the desktop are numbered from bottom to top. The red arrow cursor is active, and the message bar displays “Match Next? Y/N”. Press **Y** to search for another matching frame, or press **N** to end the search.
- 9 If the search is unsuccessful, the message “No matches” appears in the message bar, and the cursor changes to a red arrow. Use the red arrow to select another reel to search, or click anywhere outside a clip to cancel the search.

NOTE To cancel a search at any point, click anywhere inside the menu.

Navigating the Filesystem

When you work with Flame, many resource files such as setups, preferences, and EDLs reside on the filesystem. Image import and export procedures also require filesystem navigation. Use the file browser to locate, load, and save files.

The file browser contains file browsing, selection, and display options, as well as file management utilities to create directories and delete selected files.

To provide an example of how one might access the file browser, the following procedure describes how to open the file browser to import images.

To open the file browser to import images:

- 1 With the Library button selected in the Main menu, click Load.

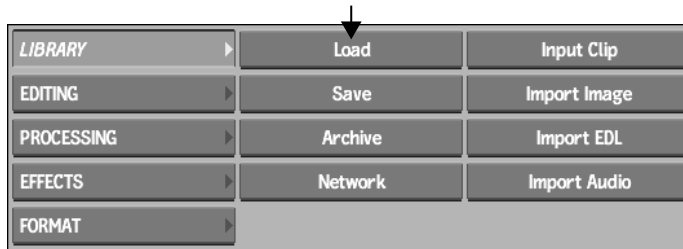

- 2 Click a reel to which you want to import images. The Load screen opens. Alternatively, instead of clicking Load from the menu and selecting a reel, you can just click the Load button inside a reel to access the Load screen directly.

- 3 In the Load screen, click Import Image.

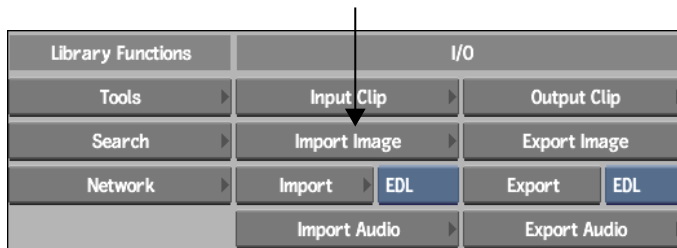

The file browser opens.

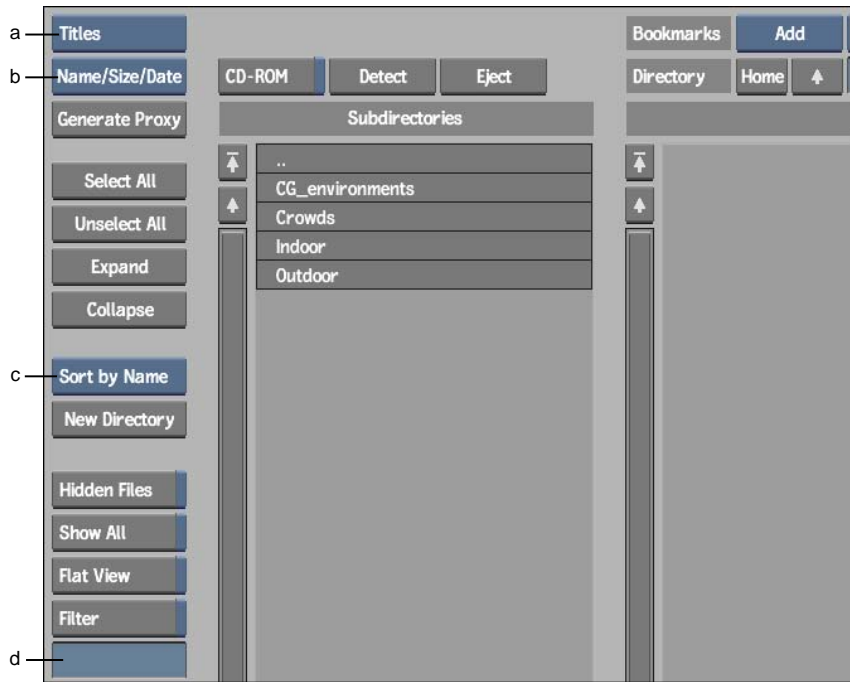

(a) Browse Mode box (b) File Information box (c) Sort box (d) Filter String field

NOTE Browser options depend on the media or resource files that you are working with, and thus the controls may change from module to module.

Browsing Files

Use the file browsing controls to locate the files or the destination directories you need.

Default Browsing Directories

The file browser opens at a default location that is the most common location for the kinds of files you are working with. For example, if you are loading an Action setup file, the file browser opens at your project's default Action setup directory.

The following illustrates the navigation controls at the top of the screen.

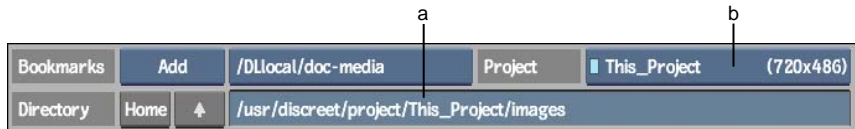

(a) Current Directory field (b) Project box

To return to the default directory:

- 1 Click Home.

To switch to the corresponding default directory of another project:

- 1 Select the Project from the Project box.

A list of directories residing in the current directory appears in the Subdirectories list. A list of the files residing in the current directory appears in the File list.

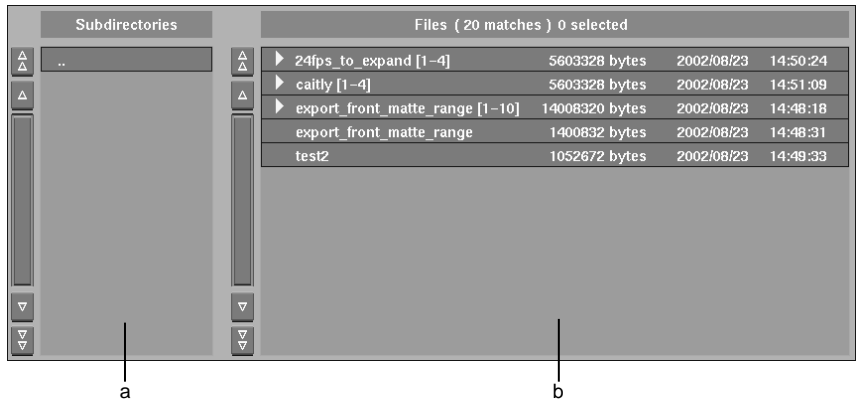

(a) Subdirectories list (b) File list

Browsing the Filesystem

You can enter subdirectories, exit current directories, or enter paths in the Current directory field to browse the filesystem.

To enter a subdirectory:

- 1 Click a subdirectory entry in the Subdirectories list.

To exit the current directory to its parent directory:

- 1 Click the “..” entry in the Subdirectories list.

You can also click , to the left of the Current Directory field.

To go to a directory immediately:

- 1 Click the Current Directory field.
- 2 Press **Esc** to clear the current contents.
- 3 Enter the path to a destination directory.

Working with Bookmarks

When you have directories that you browse to regularly, you can add bookmarks so you can browse them more quickly.

To add a bookmark:

- 1 Browse to the directory that you want to add as a bookmark.



(a) Edit Bookmarks box (b) Bookmarks box

- 2 From the Edit Bookmarks box, select Add.

To delete a bookmark:

- 1 From the Bookmarks box, select the bookmark that you want to delete.
- 2 From the Edit Bookmarks box, select Delete.

To go to a bookmarked directory:

- 1 From the Bookmarks box, select a bookmark.

Setting Browser Display Options

The file browser provides options for displaying files as titles or proxies. You can also sort the File list by name or by date. By default, the file browser filters the kinds of files associated with the current operation. However, you can override the default file filtering option.

Browsing Titles and Proxies

By default, the file browser shows the titles of files in the current directory. If you are browsing the filesystem for effects setups, you can browse with proxies instead of titles. Proxies provide a visual context for the files you are browsing. In the case of setups, a snapshot of the effect at the time the file was saved is used as a file proxy.

To browse titles:

- 1 From the Browse Mode box, select Titles.
- 2 From the File Information box, select an option.

Select:	To view:
Name/Size/Date	File names, size, and date last modified in the File list.
Name	Only file names in the File list.

To browse proxies:

- 1 From the Browse Mode box, select Proxies.
- 2 From the Proxy Size box, select Small, Medium, or Large.

TIP To view hidden files in directories, enable Hidden Files.

Sorting Files in the File List

Sort files in the File list by name or date.

To sort files in the File list:

- 1 From the Sort box, select an option.

Select:	To sort files:
Sort by Name	Alphanumerically (descending) by name.
Sort by Date	Chronologically (descending) by date last modified.

Filtering Files in the File List

You can set a filter to display files only of a certain type.

To filter files in the File list:

- 1 Enable the Filter button.
- 2 Click the Filter String field and enter a string, such as a file extension.

TIP You can filter for any string—not just file extensions—and use wildcards.

- 3 Press **Enter**.
- 4 To disable the current filter and view all files, disable the Filter button.

Flattening the Display of Files in a Directory

By default, files belonging to an image sequence are grouped in the File list. You can view all files in a directory as separate entries, even if they are part of an image sequence.



To view all files in a directory as separate entries:

- 1 Enable Flat View.

Expanding and Collapsing Image Sequences

When Flat View is disabled, image sequences are detected and grouped in a list item that you can expand and collapse. Collapse the list item to view the sequence as a single entry. Expand the list item to view the frames of the image sequence.

To expand and collapse image sequences:

- 1 Do one of the following:
 - From the Sequence Display box, click Expand or Collapse, or;
 - Click the arrow next to an image sequence ( or ).

Refreshing the Current View

Sometimes filesystem changes occur while you are browsing a directory's contents.

To refresh the view:

- 1 Click Refresh.

Managing Files and Directories in the File Browser

You can create directories to save files, or delete files from the File list.

To create a directory:

- 1 Click Create Dir.
The keyboard appears.
- 2 Enter a name for the directory and then press **Enter**.

To delete files from the File list:

- 1 Select the file(s) that you want to delete.
- 2 Click Delete and then Confirm, or press **Enter**.

Selecting and Loading Files

To load a file, you must first select it in the File list. You can load a single file, a range of files, or all files in an image sequence. You can also load files from a CD-ROM or floppy disk if these devices are connected to your system.

To select and load files:

- 1 Select the files you want to load:
 - To select a single file, click the file in the File list.

- To select a range of files, **Shift**-click the first and last file in the range. Alternatively, click and drag across the desired files in the File list.
- To add a file to a selection, **Ctrl**-click the file or press the pen button while selecting the file in the File list.
- To select all files in an expanded image sequence, double-click any of its files in the sequence in the File list.
- To select all files in the list, click Select All. Click Unselect All to unselect all files.

2 Click Load.

To load files from a CD-ROM:

- 1 Ensure that the CD-ROM is mounted. For instructions on mounting a CD-ROM, see the *Autodesk Visual Effects and Finishing Software Installation Guide*.
- 2 In the file browser, enable CD-ROM.
- 3 Click Detect.
The files on the CD-ROM appear in the file browser, and CD-ROM is automatically enabled.
- 4 Select a file and click Load.
The file is loaded.
- 5 When you are ready to remove the CD-ROM, click Eject.

To load from or save to a floppy disk:

- 1 In the file browser, enable Floppy.
- 2 Click Detect.
The type and size of the disk are automatically detected. The files on the floppy disk appear in the file browser, and Enable Floppy is automatically enabled.
- 3 Select a file and click Load.
The file is loaded.
- 4 When you are ready to remove the disk, click Eject.

NOTE If you change the disk in the floppy drive, click Detect to refresh the File list in the file browser.

Topics in this chapter:

- [About the Player](#) on page 93
- [Playing Clips in the Player](#) on page 94
- [Setting Player Display Options](#) on page 99

About the Player

You can play clips that you work with on the Desktop in the Player module.

The Player contains tools for visual overlays and reference views, providing options for monitoring sources, clips-in-progress, and rendered results. You can also apply 3D LUTs to clips in the Player. These tools are available in all module image windows. See [Module Essentials](#) on page 107.

The Player plays source or processed clips in real time. Some systems may not be capable of playing high-resolution clips in real time unless you play them from memory. Some soft effects can be rendered in real time.

When working with high-resolution clips, you can view them in the fullscreen Player. The fullscreen Player can display HD 1920x1080 clips at their native size (provided your graphics monitor supports, and is set, to display 1920 pixels across). The fullscreen Player supports most of the same features as the Player.

Playing Clips in the Player

Load clips from the Desktop into the Player. The Player provides the controls you need to play clips of any resolution, navigate clips, change the pan and zoom settings, and monitor up to two tracks of audio.

There are a few ways to load clips from the Desktop into the Player.

NOTE A clip may require more time to load if one or more soft Axis effects are applied to it. This only occurs when the clip is loaded for the first time into the Player module or played back on the Desktop. It loads normally upon subsequent use.

To load a clip into the Player from the Desktop:

- 1 With the clip that you want to load into the Player on a Desktop reel, move the clip over the reel controls.



Image courtesy of Optimus

- 2 Click Play or, with the cursor over the clip, press **Esc**.
The Player appears with the selected clip. The Clip & Setup tab displays clip information, including the clip name, resolution, number of frames per second.

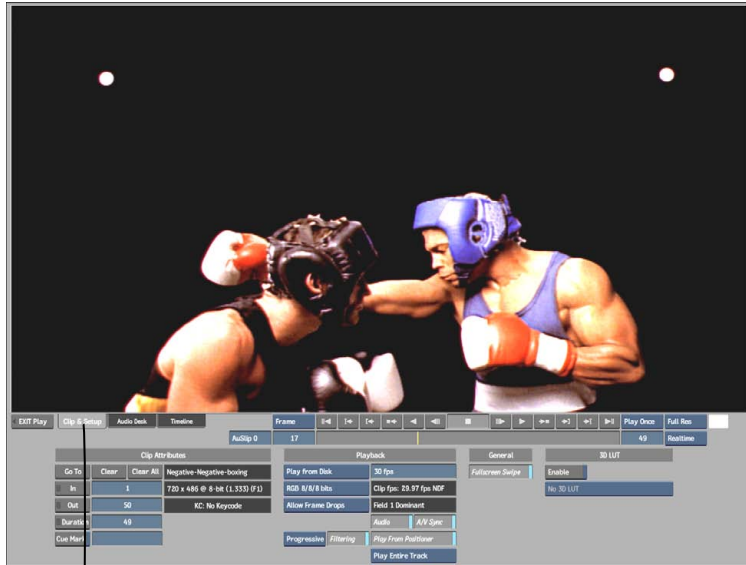





(a) Clip & Setup tab

Image courtesy of Technicolor (formerly Toybox)

- 3 Use the playback controls to play the clip. See [Controlling Playback in the Player](#) on page 96.
 Use the Clip Attributes area to set in and out points and cue marks on specific frames of a clip. See [Marking Frames of Interest](#) on page 1007 and [Setting In Points and Out Points](#) on page 1003.
 Use the tabs to access the Player's Clip & Setup, Timeline, and AudioDesk menus.
 - To work with the timeline, see [Navigating the Timeline](#) on page 969.
 - To work with the AudioDesk, see [Audio](#) on page 1195.

TIP You can use the colour pot next to the Exit Play button to sample colours from the clip. It does not set the colour of anything in the Player.

To load an entire reel into the Player from the Desktop:

- 1 With the clip or clips that you want to load into the Player on a Desktop reel, hold the cursor over a clip on the reel.
- 2 Press **Ctrl+Esc**.
The Player appears with the first of the clips on the reel displayed. The clip's name appears in the Clip Name field and the clip's resolution appears in the Clip Resolution field (this field cannot be edited).
- 3 Use the playback controls to play through the play list:
 - To jump to the next clip and continue playing at the first frame, go to the last frame of the current clip and then click  .
 - To jump to the previous clip and continue playing backward at the last frame, go to the first frame of the current clip and then click  .
 - To jump to the first frame of the next clip without playing, go to the last frame of the current clip and click  .
 - To jump to the last frame of the previous clip without playing, go to the first frame of the current clip and then click  .

Controlling Playback in the Player

You can play a clip in the Player using the playback controls that appear below the image window. The following image represents the backward playback controls and the Stop button.

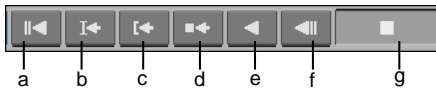

(a) Go to first frame of clip (b) Go to previous cue mark (c) Go to in point (d) Go to previous keyframe (e) Play clip backward (f) Go backward one frame (g) Stop playing clip

The following image represents the forward playback controls.

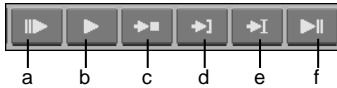

(a) Go forward one frame (b) Play clip forward (c) Go to next keyframe (d) Go to out point (e) Go to next cue mark (f) Go to last frame of clip

You can also jog the clip by dragging the yellow positioner in the timebar.

Another way to navigate a clip in the Player is to use the arrow keys on your keyboard. By default, pressing the **left arrow** and **right arrow** keys steps frame-by-frame.

Monitoring the Current Location

Monitor the location of the current frame by referring to the Current Frame field and the positioner in the timebar. The Duration field indicates the total duration of the clip.

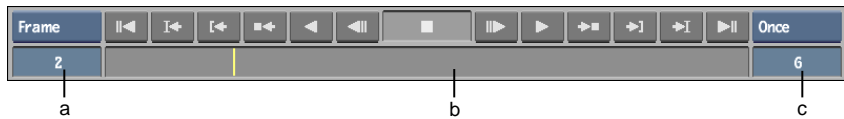

(a) Current Frame field (b) Timebar (c) Duration field

Current Frame field Displays the frame number or timecode of the current frame. You can jump to a frame by entering a frame number or timecode in this field.

Timebar Represents the duration of the clip. The positioner (the yellow marker) indicates the frame you are viewing relative to this duration. You can scrub the clip by dragging the positioner.

Duration field Displays the duration of the clip in frames or timecode. Click this field (or press **Ctrl+Alt+T**) to cycle between frame numbers, source timecode, and record timecode. You can also enable Show All TC to view all timecode at the same time.

To set the default display to frame numbers or timecode, see [Displaying Timecode and Keycode](#) on page 405.

Changing the Player's Zoom and Pan Settings

You can pan the Player window on-screen, and change its zoom factor.

NOTE Zoom and pan controls for the image window in modules are identical.

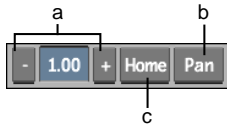

(a) Zoom controls (b) Pan button (c) Home button

Zoom In button Click Zoom In (or press **Ctrl+up arrow**) to zoom in on the clip using preset increments. The current zoom factor appears in the Zoom field.

Zoom Out button Click Zoom Out (or press **Ctrl+down arrow**) to zoom out of the clip in preset increments.

Zoom field Displays the current zoom factor. You can enter a zoom factor directly in the field.

Pan button Click Pan (or press **spacebar** as you drag) and the cursor becomes a hand with which you can drag the clip window to another location.

Home button Click Home (or press **Home**) to restore the clip window to its default settings (zoom and pan). Click Home again to return to the settings prior to restoring defaults.

TIP Press **Ctrl+spacebar** and drag right to zoom in or left to zoom out.

Monitoring Clips with Audio

If you load a clip into the Player that has audio tracks, you can also slip the audio tracks relative to the video frames. To turn on audio playback, enable the Audio button in the timeline or the Player Setup menu.

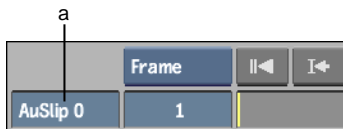

(a) Slip Field

Slip field Enter a value in the Slip field to slip the audio relative to the video.

NOTE To turn on audio playback, enable the Audio button in the timeline or the Player Setup menu.

Setting Player Display Options

The Player provides display options that you can use to customize the playback and monitoring environment. You can adapt the playback environment to your needs throughout the course of your project, whether you are reviewing a clip in progress or showing clips to your clients.

Use these options to define playback mode, resolution, preview overlays, and memory management.

Setting Playback Resolution and Mode

Use the playback mode and resolution options to define how you want clips to play and at what resolution.

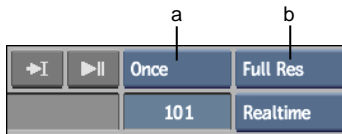

(a) Playback Mode box (b) Playback Resolution box

To set playback mode and resolution:

- 1 Select an option from the Playback Mode box.

Select:	To:
Play Once	Play through the clip one time.
Ping Pong	Continuously play in a forward and backward cycle.
Loop	Play in a continuous loop.

- 2 Select an option from the Playback Resolution box.

Select:	To:
Full Res	Play back the full-resolution clip.
Proxies	Play back using the clip's proxies.

NOTE The resolution options are active only if the clip you loaded into the Player has proxies. They are available from both the standard and fullscreen Player. To load clips into the Player using proxies, see [Setting Proxy Management Options](#) on page 532. As well, Proxy-Size Player must be enabled in the Player section of the Preferences menu.

Displaying the Fullscreen Player

For high-resolution images, use the fullscreen Player.

To display the fullscreen Player:

- 1 With a clip already loaded in the Player, swipe the left or right side of the screen.
The fullscreen Player appears.
- 2 To return to the Player, swipe the side of the screen again.

To disable the fullscreen swipe:

- 1 With a clip already loaded in the Player, click the Clip & Setup tab.
- 2 Disable Fullscreen Swipe.

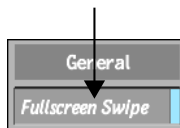

Setting the Playback Range

By default, when you play a clip from disk, you play it from its first frame to its last frame. If your clip has in and out points, these marks may be used to define the playback range, depending on the option you select from the Playback Range box.

NOTE If you play clips from memory, in and out points are disregarded, but you can use other options to define the playback range. See [Playing Clips from Memory](#) on page 101.

To set the playback range:

- 1 Click the Clip & Setup tab.
- 2 From the Source Feed box, select Play from Disk.

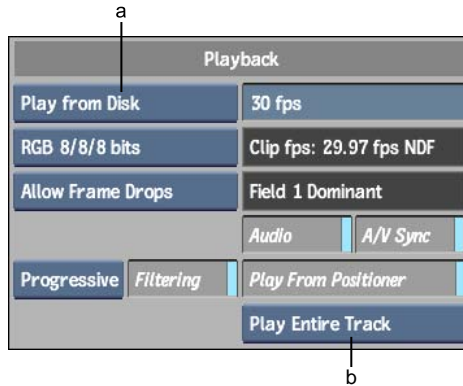

(a) Source Feed box (b) Playback Range box

- 3 Select an option from the Playback Range box.

Select:	To play the clip from:
Play Entire Track	The first frame to the last frame.
Play In to End	The in point (if marked) to the last frame.
Play Start to Out	The first frame to the out point (if marked).
Play In to Out	The in point to the out point (if marked).

Playing Clips from Memory

By default, the Player plays clips from disk using the framerate of the project's default resolution, and the frame depth of the clip, in real time. Under some conditions, however, real-time playback cannot be delivered using the default Player settings. When this occurs, Flame plays back as many frames per second as your system can render on-the-fly. These conditions include:

- If the clip's resolution is too high (frame size or frame depth, or both). In this case, you can play the clip from memory instead of from disk.

- If the clip has soft effects, transitions or soft clip resize settings. In this case, play the clip from disk, but disable some effects that Flame otherwise tries to render on-the-fly.

To deliver real-time playback under these conditions, you can set options in the Player Setup menu to reduce playback frame depth, play clips from memory, or disable soft effects that are not necessary for review purposes. You can also force audio sync to keep audio in sync with video when Flame cannot provide real-time playback.

NOTE The yellow positioner turns blue to indicate dropped frames. It turns orange to indicate real-time playback with no dropped frames of soft-imported clips.

To play a clip from memory:

- 1 Click the Clip & Setup tab.
- 2 Select Play from Memory from the Source Feed box.



The clip is cached, and controls appear to set the play-from-memory options.

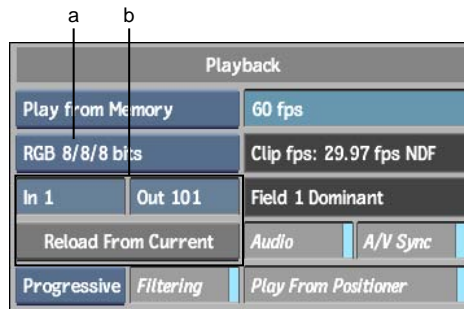

(a) Frame Depth box (b) Play from Memory controls

- 3 If the clip that you want to play from memory is large relative to the amount of memory you have, select an option from the Frame Depth box.

Select:	To reduce playback frame depth to:
Monochrome 8 bits	8-bit (total) greyscale.
RGB 3/3/2 bits	8-bit (total) colour.
RGB 5/5/5 bits	16-bit (total) colour.
RGB 8/8/8 bits	24-bit (total) colour; 8 bits per channel colour. This option only benefits playback of 12 bits or 16 bits (12 bits unpacked) per channel clips.
RGB 12/12/12 bits	36-bit (total) colour. This option loads the clip in memory without dropping bit depth and is available only for 10, 12, and 12 unpacked clips.

- 4 To limit the range of frames stored in memory, enter frame numbers or timecode in the In and Out fields.

In the timebar, in and out caching marks indicate the current range.

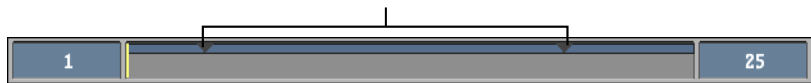

TIP You can also drag the in and out marks along the range display in the timebar to set the playback range.

- 5 Play the clip.
If you set a range of frames to load into memory that exceeds your RAM capacity, the maximum number of frames is loaded, beginning from the In value or beginning of the clip.
- 6 If the clip's playback halts due to insufficient memory, click Reload From Current to reload the clip from the current frame to the end of the range you have set to play from memory.

To change preview rendering settings:

- 1 Select an option from the Preview option box.



Select:	To render:
Preview FX	All soft effects on-the-fly. If the soft effects cannot be rendered in real time, frames are dropped.
Realtime	Only those soft effects that can be rendered in real time.
View Src	No soft effects, and play back only the source clip.

TIP Options selected from this box only affect playback from disk.

Changing the Playback Framerate

You can change the rate at which clips are played. For example, to play a clip in which you step-frame processed every second frame, play it back at half speed so its timing is similar to a fully processed clip.

To change the playback framerate:

- 1 Click the Clip & Setup tab.
- 2 In the FPS field, enter the framerate at which you want the current clip to play back.

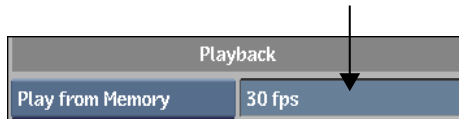

Changing Playback Scan Mode Options

The options in the Scan Mode box let you view interlaced and progressive material correctly when displayed at a size other than their actual size, for example, when you play an HD clip in the Player with the clip zoomed in or out. This option defines the method used to resize the current frame.

To change playback scan mode options:

- 1 Click the Clip & Setup tab.
- 2 From the Scan option box, select a scan mode for the clip.

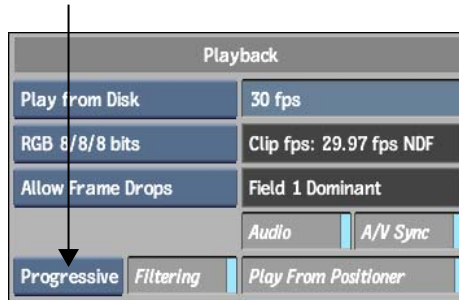

Select:	To:
Progressive	Resize the frame as a progressive frame. Use this option for progressive material. When applied to interlaced material, field integrity is not retained.
Field 1	Display only field 1 of an interlaced clip when the clip is stopped. Alternate lines are also filled by field 1. On playback, the interlaced resize method is used.
Field 2	Display only field 2 of an interlaced clip when the clip is stopped. Alternate lines are also filled by field 2. On playback, the interlaced resize method is used.
Interlaced	Play back the clip with interlaced scan mode. When this option is selected, field 1 and field 2 are resized separately, and then interlaced, producing better results when playing back interlaced material.

Setting Audio and Video Playback Sync

Use the A/V Sync button in the Player Setup menu to force audio sync with video, even in cases where you play clips at a different framerate:

- With A/V Sync enabled, audio and video play at the framerate set in the FPS field.

- With A/V Sync disabled, video plays at the framerate set in the FPS field, but audio plays at the project's framerate. The project's framerate appears on the Desktop in the Format menu.

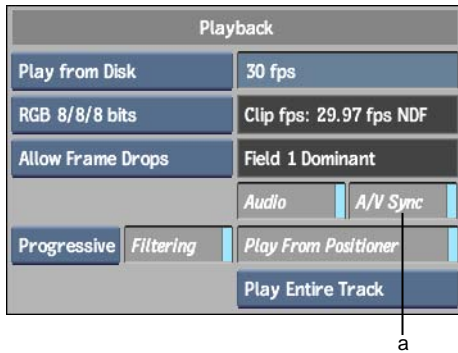

(a) A/V Sync button

For more information about working with audio, see [Audio](#) on page 1195.

3D LUTs in the Player

If you configured Flame to initialise more than one 3D LUTs, you can toggle the Player to use these LUTs instead of the default one defined in the Preferences menu. Press the associated hotkey of the LUT, (**Ctrl+Shift+[1-0]**), determined by the order in which you imported LUT into the 3D LUT list. See [Applying 3D LUTs to the Player](#) on page 738.

Module Essentials

6

Topics in this chapter:

- [About Modules](#) on page 107
- [Accessing Modules](#) on page 108
- [Viewing Clips in the Image Window](#) on page 111
- [Setting Image Window Display Options](#) on page 116

About Modules

From the Desktop, you can enter modules - discrete areas where you can modify relevant parameters or perform a group of related operations - and then return to the Desktop with a processed clip.

When you work in a module, you play and view clips in-progress in the image window. Because you may be applying effects to one or more clips at a time, real-time playback is not always possible. However, the image window still provides fast clip navigation, scrubbing, and, if you play the clip, the system renders as many frames per second as it can.

The image window provides clip display tools that aid the creative process. Use the Grid menu to display a reference grid and overlays such as letterbox, safe action and title, and centre-point.

The View menu provides some modules access to the reference area: a tool that displays reference clips or stored reference frames comparatively using a split

bar. In some modules, you can also display multiple viewports and select 3D LUTs to apply to the clip.

Accessing Modules

When you enter a module from the Desktop, you select the input clips that you want to work with. Each module allows for different variations of input clips, but the loading order is the same: front first, back second, matte third, and destination fourth. Exceptions to this are:

- The Paint and Text modules, where you have the option of entering without clips.
- The Batch module, where you can enter without clips and then input clips to the Batch desktop using Batch nodes.

To load clips into a module:

- 1 Click the module button in, for example, the Effects menu.
The cursor becomes an arrow.
- 2 Select the clip on the desktop reels by clicking its upper-left corner.

Cursor:	To select:
Red arrow	The front clip
Green arrow	The back clip
Blue arrow	The matte clip

- 3 Once all the required clips for the module are selected, the cursor becomes a white arrow. Click the desktop reel to select the destination for the processed result clip.

When you process clips from a module, they appear on the destination reel that you selected, with a red outline. The most recently processed clip on the desktop always has a red outline.

Using the Desktop Module Editor

The Desktop Module Editor lets you preview an effect before it is applied to the clip. The option is only available for certain tools, and is indicated by an “E” that appears on the button prior to selecting the clip destination.



You can preview operation results using the Desktop Module Editor. This feature allows you to perform the same functions as on the Desktop, but with the added benefit of being able to preview and, in most cases, modify, the effect before it is applied to the clip.

The desktop Module Editor is available for the following Processing commands:

- Average
- Compound
- Flip
- Logic Ops
- Auto Matte
- Monochrome
- Negative
- Posterise

The desktop Module Editor is available for the following Format commands:

- Deinterlace
- Interlace
- Field Merge
- Film Compress
- Film Expand
- Deal
- Combine

To preview an operation using the Module Editor:

- 1 Click the button for the operation you want to use.
- 2 Select the source clips.

NOTE When using the same material as in the previous session, you can automatically enter an editing module by first clicking the button when the S appears, and then selecting a destination.

When the Editing Module option is available for a tool, an E appears on the button.



- 3 Click the operation button again.
- 4 Select a destination.

The editing module appears. Use the controls in the editing module as you would on the Desktop.

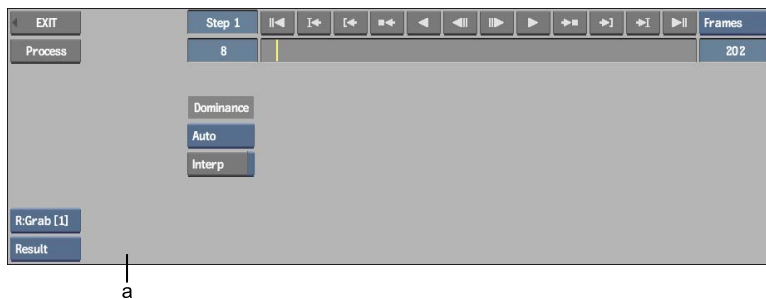

(a) Deinterlace editing module

Accessing Modules with Previous Clips

The Same Clips option is a shortcut for selecting clips from the Desktop reels when you want to access Flame modules. When you use the Same Clips option, the clips that you selected the last time you used that module during the current work session are automatically used—you do not have to manually select the clips.

The search for the same clips is done by clip ID. The desktop reels are searched first; if the clip is not found there, the current clip library is searched, and then the other clip libraries.

NOTE If a clip is deleted from the Desktop but is still in the Undo buffer, the Same Clips option will not find it, unless Undo is used to return the clip to the Desktop.

To open a module with the same clips as previously used:

- 1 Click the button for the module you want to use.
An “S” button appears to the right of the module button.



- 2 Click the module button again to activate the Same Clips option.
- 3 Select a destination.

The module opens with the clips from the previous session (if they are found). The most recent settings are also restored.

NOTE If you select the Same Clips option and have not used the module in the current work session, or if the clips cannot be found, an error message is displayed indicating that no previous clips were selected.

Viewing Clips in the Image Window

When working on clips in modules, you view the effects of your work in the image window. The image window is similar to the Player except it renders uncommitted effects on-the-fly. As a result, real-time playback is frequently unsupported; however, the system plays back as many frames per second as it can render.

When you process clips in a module, you can load them into the Player for real-time playback without having to exit the module.

Controlling Playback in the Image Window

Use the playback controls below the image window to play and navigate the clip. You can also use the playback controls to change the frame displayed in the image window.

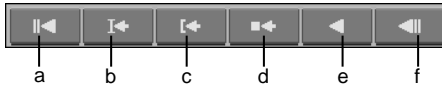

(a) Go to first frame of clip (b) Go to previous cue mark (c) Go to in point (d) Go to previous keyframe (e) Play clip backward (f) Go backward one frame

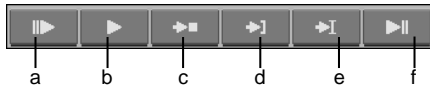

(a) Go forward one frame (b) Play clip forward (c) Go to next keyframe (d) Go to out point (e) Go to next cue mark (f) Go to last frame of clip

The elements directly below the playback controls are the following.

Current Frame field Displays the frame number or timecode of the current frame. You can jump to a frame by entering a frame number or timecode in this field.

Duration field Displays the duration of the clip in frames or timecode. In some modules, you can change the length of the generated clip by changing the total number of frames in this field.

Timebar Represents the duration of the clip. The positioner (a yellow marker) indicates the frame you are viewing relative to this duration. You can scrub the clip by dragging the positioner.

Zooming and Panning the Image Window

The zoom and pan controls are located to the right of the image window controls. Use these controls to zoom in, zoom out, and pan the image. If more than one viewport is displayed in the image window, select the viewport you want to pan or zoom.

To zoom the image window:

1 Do one of the following to zoom in:

- Click + .

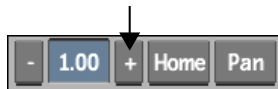

- Press **Ctrl+spacebar** and drag right.

2 Do one of the following to zoom out:

- Click - .



- Press **Ctrl+spacebar** and drag left.

3 Click Home to restore the default zoom factor.



4 **Ctrl-click** Home to fit the image window to the viewport.

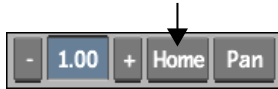

To pan the image window:

1 Click Pan.



The cursor changes to a grabber hand.

- 2 Move the grabber cursor into the image window.
- 3 Press down and drag the image window.

TIP You can also hold down **spacebar** and then drag over the image window to pan it. In the Text module, use **Ctrl+Shift+spacebar** to pan.

Displaying Clip Views

When you enter a module from the Desktop, the image window usually displays the result clip. In Batch and the Modular Keyer, the default view is the schematic. You can display the result clip of the currently selected node

in the image window by swiping the side of the screen. You can change the display of the image window to view relevant context for the process. Select clip display options from the View box to view the different clips that you loaded. The options available in this box depend on the module, its input clips (front, back, matte, and so on), and any other context views it supports.

To display a clip view:

- 1 Select an option from the View box or press its associated hot key.

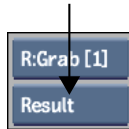

Select:	To view:
Front (F1)	The front clip.
Back (F2)	The back clip.
Matte (F3)	The matte clip.
Result (F4)	The result clip.

Some modules support other clip view options. These options are documented in the corresponding chapters.

Accessing the Player from Modules

When you process a clip in a module, a Player button appears. Click Player to load the processed clip into the Player for real-time playback (or, depending on your hardware configuration and the clip's resolution, best-possible). Click Delete to delete the most recently processed clip.

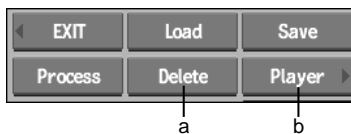

(a) Delete button (b) Player button

When you work in a module, you may want to process a clip as-is for preview purposes. In this case, the intermediate render is usually disposable. To accelerate the process, you can perform step-frame processing. With step-frame processing, you only render every second, third, fourth, or *n*th frame of the clip. Although the step-frame processed clip does not provide a completely accurate preview of a final render, it is usually sufficient, and processing time is greatly reduced.

To perform step-frame processing:

- 1 Enter a value in the Step field. For example, enter 4 to process every fourth frame.



- 2 Click Process.

Once processing is complete, the Play button appears. To compensate for step-frame processing on playback, change the playback speed. See [Changing the Playback Framerate](#) on page 104.

Scrubbing Audio in Modules

When you load a clip with audio into a module, you can scrub the audio; you can perform both locked rate and free form scrubbing. The level heard when scrubbing in modules is affected by the level set for the channels using the level meters in the AudioDesk (in Batch, the Audio menu contains the same level meters as the AudioDesk).

To scrub audio in a module:

- 1 Load a clip with audio into a module.
- 2 If there is a Play Lock option in the module's Setup menu, disable it.
- 3 Set the view as follows.

Module	View
Text	Back
Action	Media Front, Media Back, or Media Matte

Module	View
Batch	Any view
Modular Keyer	Any view
All other modules	Front, Back, or Matte

- 4 Do one of the following:
 - For a free form scrub, press **Ctrl** and drag the positioner in the timebar.
 - For a locked rate scrub, press **Ctrl+Shift** and drag the positioner in the timebar.

The audio scrubs as you drag.

You can toggle between locked and unlocked scrub modes on the fly, by alternating between the **Ctrl** and **Ctrl+Shift** hot keys.

Setting Image Window Display Options

The image window provides display options for your clip. You can display grids and guides, overlays, compare the current result against a reference area, and control RGB channel display.

Some modules support multiple viewports so you can monitor your work in multiple contexts: for example, compare the source clip with the current result. All modules that support multiple viewports also support 3D LUTs in the image window.

Working with Grids and Guides

Grids and guides are reference overlays that appear over the image window in modules.

Use grids to view an overlay for spatial reference in your clips. A lattice of horizontal and vertical lines can be helpful when trying to place objects in a scene. You can even enable snap-to-grid functionality to ensure the accuracy of your placement.

Use guides to overlay horizontal and vertical reference lines. You can verify the working area, frame aspect ratio, safe areas for action and text, and the

centre of the working area. You can also set up free guides for non-standard horizontal and vertical references.

Grids and guides are accessible from all modules using the Grid menu. However, not all modules support all grids and guides features.

To access the Grid menu:

- 1 Click the Grid button that appears on the right side of the image window controls.

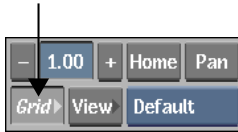

The Grid menu appears.



Use the controls in:	To:
Working Area	Define the area relevant to the output result. See Setting Up Working Area Guides on page 119.
Free Guide	Set up a freely defined rectangular overlay. See Setting Up Free Guides on page 120.
Guide	Display aspect ratio guides. See Setting Up Aspect Ratio Guides on page 121.
Safe	Display safe text and safe action areas. See Setting Up Safe Area Guides on page 124.
Grid	Display reference grids. See Setting Up Grids on page 126.
Centre	Display the centre point of the working area. See Displaying a Centre Point on page 128.

To reset grids and guides to the default settings, click Reset All in the lower-right corner of the Grid menu.

Selecting Grids and Guides Presets

You can display grids and guides presets without having to enter the Grid menu.

To select grids and guides presets:

- 1 Select an option from the Quick Guides box.

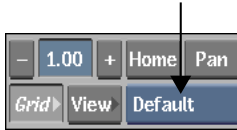

Select:	To:
PAN_16x9_to_4x3	Display reference guides for panning and scanning a 16x9 clip to a 4x3 format.
TILT_to_16x9	Display reference guides for a 16x9 letterbox clip in a 4x3 ratio.
TILT_to_14x9	Display reference guides for a 14x9 letterbox clip in a 4x3 ratio.
Default	Display the grids and guides currently defined in the Grids and Guides menu.
Quick Off	Turn grids and guides off.

TIP If you have grid and guide setups saved to your user `~/guides` directory, each setup appears as an option in the Quick Guides box.

Saving Grids and Guides Setups

You can save grids and guides setups to your user `~/guides` directory.

To save grids and guides setups:

- 1 With grids and guides displayed and configured, display the Grid menu.
- 2 Enable or disable Zoom/Pan.

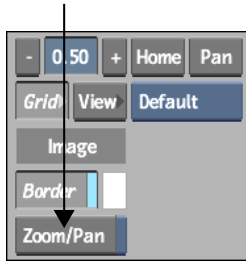

- Enable Zoom/Pan to include the current zoom and pan settings with the grids and guides setup.
 - Disable Zoom/Pan to exclude the current zoom and pan settings with the grids and guides setup.
- 3 Click Save to open the file browser.
 - 4 Set a destination for the setup, and then click Save.

TIP Grids and Guides setups saved to the default directory (*~/guides* in your user home directories) appear as options in the Quick Guides box provided you start Flame by selecting your user name.

Loading Grids and Guides Setups

You can load grids and guides setups that reside in other directories.

To load grids and guides setups:

- 1 In the Grid menu, click Load to open the file browser.
- 2 Locate the setup file using the file browser, and then click Load.

Setting Up Working Area Guides

Set up working area guides to delimit the relevant area in the frame. For example, if you are working on a film project, audio is printed in a thin strip on the side of each frame. You can set up the working area guides to indicate only the part of the film frame that is not affected by the audio print.

To set up a working area guide:

- 1 From the Working Area box, select Working Area.

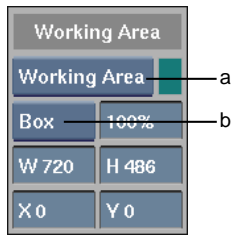

(a) Working Area box (b) Overlay Type box

- From the Overlay Type box, select Line or Box.

Select:	To:
Line	Indicate the working area by outline only.
Box	Cover the area outside the working area.

TIP If you select Box, you can change its opacity using the Opacity field that appears to the right of the Overlay Type box.

- To change the colour of the working area overlay, use the colour pot next to the Working Area box.
- To set the size of the overlay, enter values in the working area Width and Height fields.

TIP These values can be no larger than the clip's resolution.

- To offset the working area, enter values in the X and Y Offset fields.

Setting Up Free Guides

A free guide is a rectangular overlay that you can set up to mark a region of the frame. This may be useful if you are working on a background graphic for a composite where a picture-in-picture effect is applied.

To set up a free guide:

- From the Free Guide box, select Free Guide.

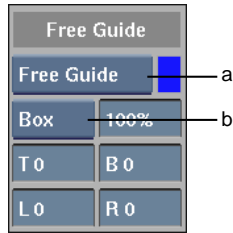

(a) Free Guide box (b) Overlay Type box

- From the Overlay Type box, select Line or Box.

Select:	To:
Line	Indicate the working area by outline only.
Box	Cover the area outside the working area.

TIP If you select Box, you can change its opacity using the Opacity field that appears to the right of the Overlay Type box.

- To change the colour of the free guide overlay, use the colour pot next to the Free Guide box.
- To set the size of the overlay, enter values in the free guide T (top), B (bottom), L (left), and R (right) fields.

TIP These values are interior offsets relative to the working area guide. If you have not set up a working area guide, these values are relative to the frame border.

Setting Up Aspect Ratio Guides

Aspect ratio guides provide an overlay for the aspect ratios of broadcast and film formats. Use the guides when you are working on a format that you will deliver in another format. By selecting the delivery format's aspect ratio, you can preview the result without processing the format conversion.

If the aspect ratio you need an overlay for is not among the preset options, you can create custom aspect ratio guides based on a decimal aspect ratio or on pixel values.

To set up a preset aspect ratio guide:

- 1 From the Aspect Ratio box, select a preset aspect ratio.

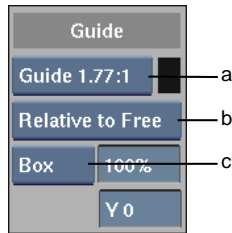

(a) Aspect Ratio box (b) Relative box (c) Overlay Type box

These options include:

- 1.37:1 (Academy)
- 1.66:1 (European 35mm)
- 1.77:1 (HDTV)
- 1.85:1 (American 35mm)
- 2.35:1 (CinemaScope)

- 2 From the Overlay Type box, select an option.

Select:	To:
Line	Indicate the working area by outline only.
Box	Cover the area outside the working area.

TIP If you select Box, you can change its opacity using the Opacity field that appears to the right of the Overlay Type box.

- 3 To change the colour of the aspect ratio overlay, use the colour pot next to the Aspect Ratio box.
- 4 From the Relative box, select an option.

Select:	To define the aspect ratio guide relative to:
Relative to Border	Frame border.
Relative to Work	Working area.

Select:	To define the aspect ratio guide relative to:
Relative to Free	Free guide.

- To offset the aspect ratio guide vertically, enter a value in the Y Offset field.

To set up a custom aspect ratio guide:

- From the Aspect Ratio box, select Custom Ratio or Custom Inside.

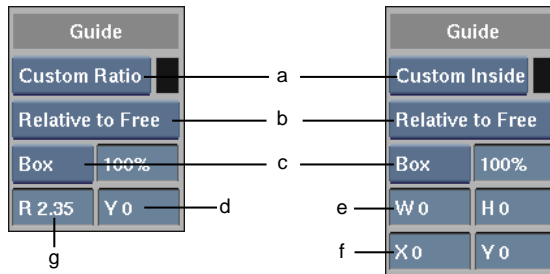

(a) Aspect Ratio box (b) Relative box (c) Overlay Type box (d) Y Offset field (e) W, H fields (f) X, Y Offset fields (g) Ratio field

- From the Overlay Type box, select an option.

Select:	To:
Line	Indicate the working area by outline only.
Box	Cover the area outside the working area.

TIP If you select Box, you can change its opacity using the Opacity field that appears to the right of the Overlay Type box.

- To change the colour of the aspect ratio overlay, use the colour pot next to the Aspect Ratio box.
- Set the aspect ratio:
 - If you selected Custom Ratio, enter the decimal ratio (for example, 1.33 for 4:3) in the R (ratio) field.
 - If you selected Custom Inside, enter values, in pixels, in the Width and Height fields. You can also offset this aspect ratio using the X and Y Offset fields.

5 From the Relative box, select an option.

Select:	To define the aspect ratio guide relative to the:
Relative to Border	Frame border.
Relative to Work	Working area.
Relative to Free	Free guide.

Setting Up Safe Area Guides

Safe area guides overlay the parts of the frame inside which you should keep relevant action in the shot, text, or other graphics:

- The safe action area marks a rectangle inside the frame, representing the amount of cropping that occurs during broadcast. This guide should line up with the edges of your broadcast monitor.
- The safe title area marks a rectangle inside the safe action area, providing a margin on all sides inside which you should place titles and graphics to ensure they are not too close to the edges of the broadcast result.

Use the safe area guide controls to select default safe area guides. You can also create a custom safe area guide.

To set up default safe area guides:

1 From the Safe Area box, select a safe area guide option.

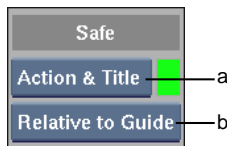

(a) Safe Area box (b) Relative box

Select:	To view:
Safe Title	The default safe title area guide.
Safe Action	The default safe action guide.
Action & Title	Both safe action and safe title guides.

- To change the colour of the safe area(s), use the colour pot next to the Safe Area box.
- From the Relative box, select an option.

Select:	To define the safe area guide relative to:
Relative to Border	Frame border.
Relative to Work	Working area.
Relative to Free	Free guide.
Relative to Guide	Aspect ratio guide.

To set up a custom area guide:

- From the Safe Area box, select Custom Safe.

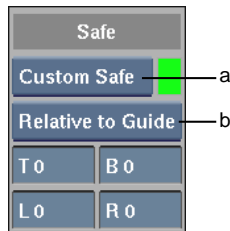

(a) Safe Area box (b) Relative box

- To change the colour of the safe area, use the colour pot next to the Safe Area box.
- From the Relative box, select an option.

Select:	To define the safe area guide relative to:
Relative to Border	Frame border.
Relative to Work	Working area.
Relative to Free	Free guide.
Relative to Guide	Aspect ratio guide.

- 4 Enter values, in pixels, in the T (top), B (bottom), L (left), and R (right) fields to set the position of each side of the safe area guide relative to the selection you made in the previous step.

Setting Up Grids

Set up a grid of horizontal and vertical lines along the XY plane to help you place objects in a scene. You can set up a grid based on rows and columns, or on a pixel scale.

To set up a grid based on rows and columns:

- 1 From the Grid box, select Row/Col Grid.

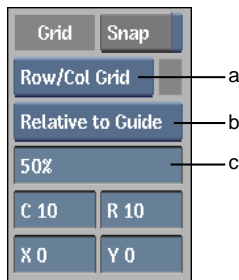

(a) Grid box (b) Relative box (c) Opacity field

- 2 From the Relative box, select an option.

Select:	To define the grid relative to:
Relative to Border	Frame border.
Relative to Work	Working area.
Relative to Free	Free guide.
Relative to Guide	Aspect ratio guide.

- 3 To change the colour of the grid, use the colour pot next to the Grid box.
- 4 Enter values into the C (columns) and R (rows) fields to define the grid.
- 5 To offset the grid, enter values in the X and Y Offset fields.
- 6 To make objects snap to grid points, enable Snap.

7 To decrease the opacity of the grid, enter a value in the Opacity field.

To set up a grid based on a pixel scale:

1 From the Grid box, select Pixel Grid.

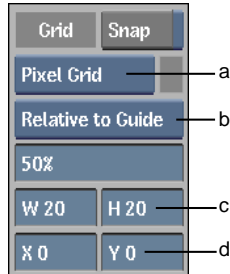

(a) Grid box (b) Relative box (c) W, H fields (d) X, Y Offset fields

2 From the Relative box, select an option.

Select:	To define the grid relative to:
Relative to Border	Frame border.
Relative to Work	Working area.
Relative to Free	Free guide.
Relative to Guide	Aspect ratio guide.

3 To change the colour of the grid, use the colour pot next to the Grid box.

4 Enter values into the W (width) and H (height) fields to define the grid. Values are in pixels, and define the number of pixels between vertical (W) and horizontal (H) lines.

5 To offset the grid, enter values in the X and Y Offset fields.

6 To make objects snap to grid points, enable Snap.

7 To decrease the opacity of the grid, enter a value in the Opacity field.

Setting Up Independent Schematic Grids

You can apply a grid to a schematic view in Action, the Modular Keyer, and Distort. Schematic grid settings are independent of those applied to other views in the module (for example, Front and Result).

When you work in Batch, you can also apply independent grid settings to the Batch schematic, Action schematic, GMask schematic, and Distort schematic. For example, you can disable the grid for the Batch schematic, enable a pixel grid for the Action schematic, and enable a grid of rows and columns for the GMask schematic.

To set up an independent schematic grid:

- 1 Select the viewport containing the schematic view for which you want to set up a grid.

NOTE If you are not using multiple viewports, the grid will be applied to the current schematic view.

- 2 Set up the grid in the Grid menu.

Displaying a Centre Point

Display a centre point to keep a constant reference to the centre of your clip. In most cases, the centre point is fixed relative to the frame border. However, you can offset the centre point, or set it relative to another guide.

To set up a centre point:

- 1 From the Centre box, select Small Centre, Medium Centre, or Large Centre.

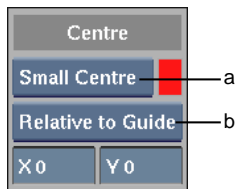

(a) Centre box (b) Relative box

- 2 From the Relative box, select an option.

Select:	To define the centre point relative to:
Relative to Border	Frame border.
Relative to Work	Working area.
Relative to Free	Free guide.
Relative to Guide	Aspect ratio guide.

- 3 To change the colour of the centre point, use the colour pot next to the Centre box.
- 4 To offset the centre point, enter values in the X and Y Offset fields.

Displaying the Frame Border

In cases where you are scaling clips so they are larger than the delivery format's frame size, it is helpful to enable the frame border display. The frame border is a thin outline of the delivery format's frame size relative to the scene.

To display the frame border:

- 1 In the Grid menu, enable Border.

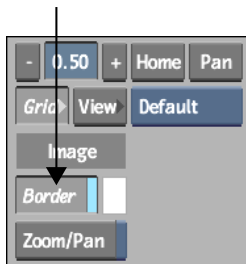

- 2 To change the colour of the frame border, use the colour pot next to the Border button.

Displaying the Proper Aspect Ratio

Some video and film formats use rectangular instead of square pixels. This explains why NTSC and PAL video formats have a different frame dimension

in terms of pixels, but are ultimately broadcast to the same 4:3 aspect ratio screen.

- NTSC pixels are narrower than they are high, which allows for the 720x486 (1.481) aspect ratio frame to fit into a 4:3 (1.333) aspect ratio broadcast screen.
- PAL pixels are wider than they are high, which allows for 720x576 (1.25) aspect ratio frame to fit into a 4:3 (1.333) aspect ratio broadcast screen.

When you capture video or import film frames that use rectangular pixels into Flame, the pixels become square because computer graphics work only with square pixels. This is why the NTSC and PAL frames appear as though they are different size—displayed with square pixels, they are.

You can set the image window to display clips originating from rectangular pixel formats using filters to simulate the use of rectangular pixels. This provides a display that corresponds with the delivery format.

Using the aspect ratio display affects system performance, so if you are using the aspect ratio filter and notice a performance slowdown, you can disable the option and return to square-pixel display.

NOTE Many HD video formats such as 1920x1080 and 1280x720 use square pixels, so enabling this option has no effect. One HD video format that does use “slightly” rectangular pixels is 1920x1035.

To display the proper aspect ratio:

- 1 In the View menu, enable Use Ratio.

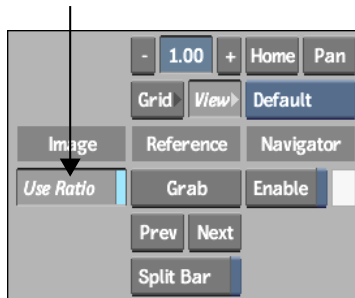

Displaying the Reference Area

In the image window of the Modular Keyer, Distort, Action and Resize, you can view the reference area with the currently displayed clip. A split bar divides the view between the current clip display (above the bar) and the reference area. The reference area can either display one of the current module's working clips (for example, front, back, or matte), or one of the reference frames that you grab on-the-fly.

Turning On the Split Bar

Turn on the split bar from the View menu or by using a hot key in any module where you can view reference frames.

To turn on the split bar:

- 1 Enable Split Bar (or press **Ctrl+B**).

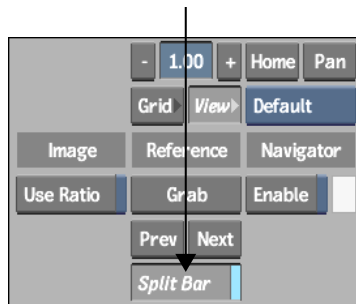

Moving the Split Bar

When the split bar is on, by default it lies along the lower edge of the image window.

The split bar has a pivot point (indicated by a small box) around which the split bar can be rotated, or from which the split bar can be moved. The letter R next to the pivot box indicates the side of the bar where the reference clip is displayed.

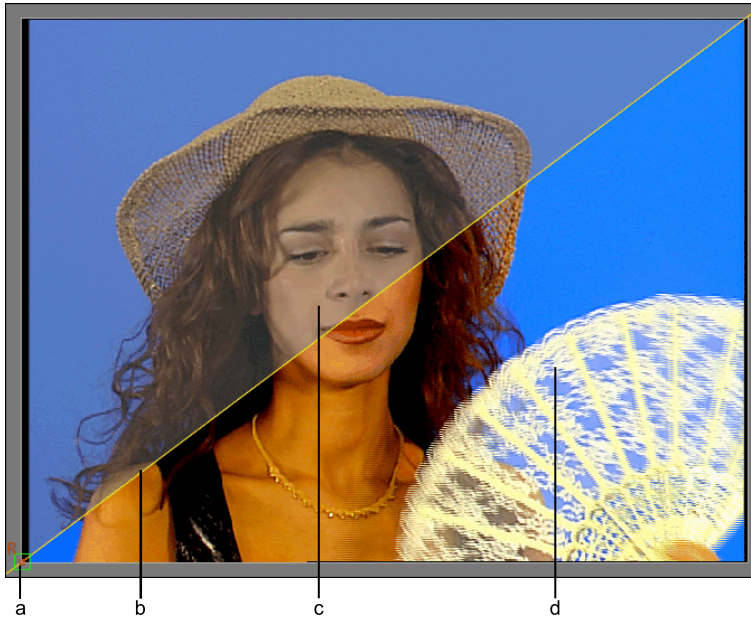

(a) Pivot point (b) Split bar (c) Current display (d) Reference display

Rotate and move the split bar using these techniques:

- To rotate the split bar around its pivot point, drag the split bar.
- To move the split bar, drag the pivot point. You can also **Ctrl+Alt**-click the image to place the pivot point under the cursor, and then drag over the image to move the split bar.
- To restore the split bar to its default position, **Ctrl**-click the pivot point.

NOTE Depending on your hardware configuration and your project's bit depth, you may only be able to rotate the split bar in 90-degree increments.

Showing and Hiding the Split Bar

When the split bar is on, you can show or hide it in the image window.

To show or hide the split bar:

- 1 **Ctrl**-click the split bar.

When the split bar is hidden, it is still active. The letter R is displayed indicating the location of the reference clip.

Loading a Clip into the Reference Area

You can display one of the module's clip views in the reference area. For example, turn on the split bar to show the reference area, and then display the matte of Action media while working on its result.

To load a clip into the reference area:

- 1 Select an option from the Reference box.

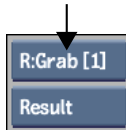

Storing Reference Frames in the Reference Buffer

Flame has a graphics buffer that is dedicated to storing reference frames. In Distort, the Modular Keyer, Action, Batch, the Colour Corrector, and Resize, you can display these frames in the reference area to compare the current result of a clip with a snapshot that you took earlier in the creative process.

You can grab any number of reference frames in the reference area, limited only by framestore space.

To store reference frames in the reference area:

- 1 Display the frame you want to grab in the viewport.
- 2 In the View menu of a module, click Grab (or press **Ctrl+G**).

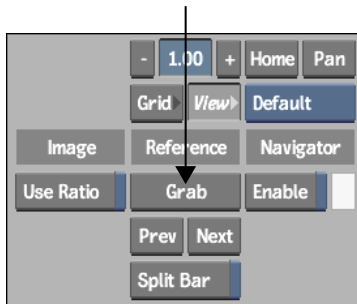

The current frame appears in the reference area.

- 3 To grab another frame, display it in the viewport (or make the changes to the current frame) and then do one of the following:
 - Press **Ctrl+G** to replace the current reference frame.
 - Press **Ctrl+Shift+G** to append the new frame to all existing reference frames.

Cycling Through Multiple Reference Frames

When you work with several frames stored in the reference buffer, you can cycle their display in the reference area.

To cycle through multiple reference frames:

- 1 With the split bar on and the reference area showing, click the Prev and Next buttons in the View menu.

To cycle through multiple reference frames using the reference overlay:

- 1 Press and hold **Ctrl+NUM5** to display the reference overlay.
- 2 While holding **Ctrl**, press **NUM4** and **NUM6** to cycle backwards and forwards through all stored reference frames.

TIP The reference overlay works from any location in Flame, even on the Desktop.

3D LUTs in the Image Window

If you enable 3D LUT processing, you can apply 3D LUTs to the image window (in modules that support multiple viewports), the reference area, and the reference overlay .

The 3D LUT options are available from the image window's View menu.

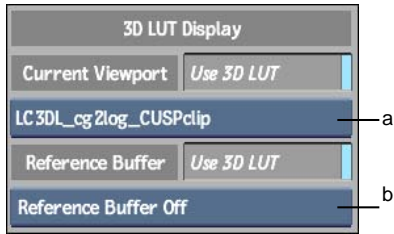

(a) Current Viewport 3D LUT List box (b) Reference Buffer 3D LUT List box

Use 3D LUT button Enable 3D LUT display mode for the current viewport or the reference buffer.

3D LUT List box Select a 3D LUT to be applied to a clip in the currently selected viewport or the reference overlay.

See [Applying 3D LUTs to the Image Window](#) on page 739.

Monitoring RGB Channels Independently

When working in a module that supports multiple viewports, you can monitor the red, green, and/or blue channels of clips, or a greyscale representation of any channel, in the image window.

To monitor the red, green, and blue channels independently:

- 1 Display the View menu.
- 2 Toggle the R, G, and B buttons in the Viewing area to change the display of the red, green, and blue channels, respectively.

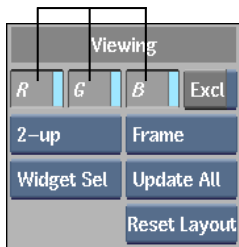

- 3 To monitor an exclusive greyscale representation of the red, green, or blue channel, enable the Excl button and then the R, G, or B button.
- 4 To restore full RGB display, disable Excl, and then enable R, G, and B.

Monitoring Full Frames and Dominant Fields

When you are working in Resize, the Colour Corrector, the Modular Keyer, Distort, Batch, or Action, the full frame of an image is displayed in the image window by default. When working with interlaced video, you can set the image window to display only the dominant field. In this case, the lines representing the dominant field are doubled.

To monitor the full frame or dominant field:

- 1 Display the View menu.
- 2 Select an option from the Frame Display box.

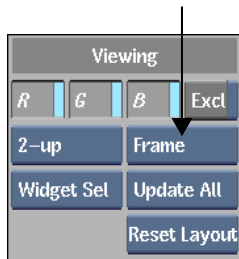

Displaying Multiple Views

You can display up to four viewports at a time in the image window of most modules. Multiple viewports are convenient for setting channel values, working in Schematic view, and previewing your results all at the same time without having to switch views.

NOTE The Resize module supports two viewports; other modules support up to four viewports.

You can apply a different 3D LUT to each viewport. See [Working with Multiple Views and 3D LUTs](#) on page 741.

To view multiple viewports:

- 1 In a module that supports multiple viewports, for example, Action, click View.
- 2 Select an option from the Viewport Layout box.

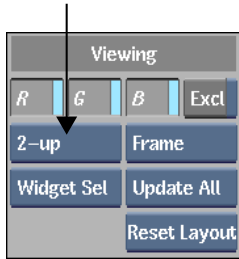

Select:	To view:
1-up	A single viewport (Alt+1).
2-up	Two viewports, side-by-side (Alt+2).
3-up wide	Three viewports, side-by-side (Alt+3).
3-up	Three viewports, two side-by-side, and one on top (Alt+3).
4-up	Four viewports, two up and two down (Alt+4).

Using a Viewport Navigator

You can enable a viewport navigator in any module that supports multiple viewports. The navigator displays an overlay of the viewport's area of interest. You can adjust the area of interest gesturally as an alternative to zooming and panning the view.

To use the viewport navigator:

- 1 In a module that supports multiple views, click View.
- 2 With a viewport selected, select Enable.

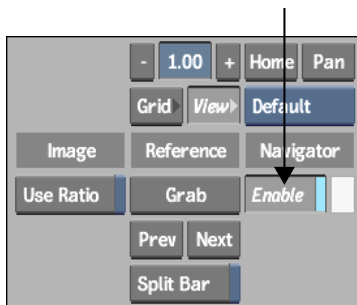

The viewport navigator appears in the selected viewport. A grey outline indicates the current area of interest.

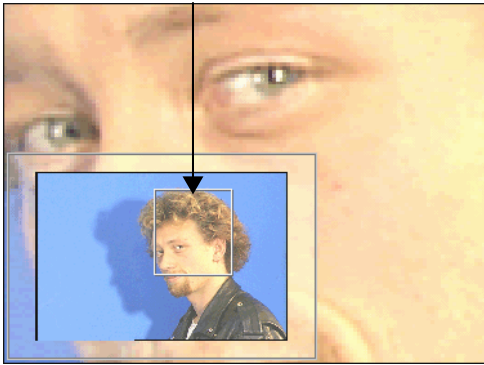

- 3 To adjust the area of interest:
 - Drag over the area of interest to move it. For example, to view schematic nodes that appear to the right of the viewport, drag the area of interest right in the viewport navigator.
 - **Ctrl**-drag a new box to change the area of interest.
- 4 You can also **Alt**-drag the viewport navigator to move it.

Displaying Widgets in Selected Viewports

If you are working in multiple viewports, you can display widgets such as icons, crop boxes, and 3D histograms in all viewports or in a selected viewport.

To display widgets in selected viewports:

- 1 In a module that supports multiple views, click View.
- 2 From the Widget Display box, select Widget Sel to display widgets in the selected viewport, or select Widget All to display widgets in all viewports.

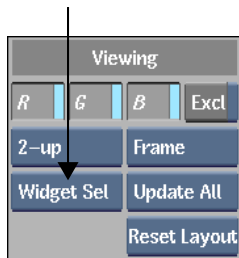

Changing the Multiview Layout

When you select a multiple viewport layout, a default layout appears, and each viewport is set to display a default view. You can change both the default layout and the views in each viewport to suit your needs.

To change the default viewport layout:

- 1 Do one or more of the following:
 - Hold the cursor over the lines dividing the image window and drag. The current zoom/pan settings of affected viewports are unchanged. (You can **Ctrl**-click the Home button to set the width of the frame to match its viewport.)
 - Hold the cursor over the lines dividing the image window and **Ctrl**-drag. The current zoom/pan settings automatically change so the frame matches its viewport's width.
 - Select the viewport to make it current (a yellow border indicates the current viewport) and then select a view option (for example, Front) or press a hot key (for example, **F1**).
- 2 To restore the default settings, select an option from the Reset box.

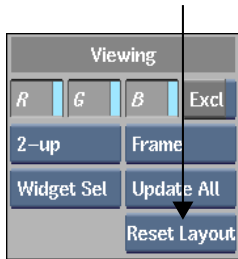

Select:	To:
Reset Layout	Restore the default layout for the current viewport layout option. You can also Alt -click a viewport border.
Reset All	Restore the default layout for all viewport layout options.

Synchronizing Current Frame Display Across All Viewports

By default, when you scrub or jog a clip, only the current viewport (a yellow border indicates the current viewport) is updated. The other viewports continue

to display the last frame at which they were parked until you release the cursor. However, you can set all viewports to be updated in sync with the current viewport.

To synchronize the current frame display across all viewports:

- 1 Display the View menu.
- 2 Select an option from the Viewport Update box.

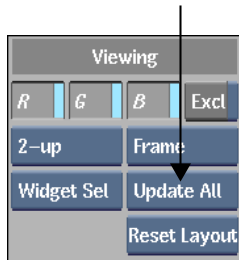

Select:	To:
Update All	Update all viewports to display the same frame as the current viewport.
Update Sel	Update only the current viewport. Other viewports continue to display the last frame at which they were parked only once you release the cursor.

Working with Multiple Viewports and a Broadcast Monitor

By default, Flame sends the graphics signal of the upper-right viewport to the broadcast monitor. However, you can set any viewport to be sent to the broadcast monitor at any time.

To send a viewport to the broadcast monitor:

- 1 Click the viewport that you want to send to the broadcast monitor to make it current (a yellow border indicates the current viewport).
- 2 Press **Ctrl+Alt+M**.

Part 3: Inputting and Outputting Media

Part 3 includes these chapters:

- [Clip Input/Output Using a VTR](#) on page 143
- [Clip Input/Output Using HSDL Devices](#) on page 187
- [Importing Media Files](#) on page 193
- [Exporting Media Files](#) on page 233
- [Unlinking and Relinking Media and Clips](#) on page 269
- [Processing and Publishing](#) on page 291



Image courtesy of Efe-x S.A

Clip Input/Output Using a VTR

7

Topics in this chapter:

- [About Clip Input and Output Using a VTR](#) on page 144
- [Configuring Hardware For Clip Input and Output Using a VTR](#) on page 145
- [Configuring Software For Clip Input and Output Using a VTR](#) on page 145
- [Inputting Clips From a VTR](#) on page 146
- [Outputting Clips To a VTR](#) on page 153
- [Monitoring Video During Clip Input and Output Operations](#) on page 161
- [Setting Input and Output In and Out Points](#) on page 162
- [Inputting and Outputting a Live Video Signal](#) on page 163
- [Working with Multi-Format Input and Output](#) on page 164
- [Inputting and Outputting HD Material](#) on page 168
- [Generating Proxies](#) on page 168
- [Capturing Proxies Only](#) on page 169
- [Capturing Material with Variable Frame Rate](#) on page 170
- [Controlling a VTR](#) on page 171
- [Adjusting Audio Gain on Clip Output](#) on page 174
- [Setting Video Input and Output Engineering Menu Controls](#) on page 175
- [Inputting and Outputting with Headroom](#) on page 180
- [Capturing 60i Material with 2:3 Pulldown Removal](#) on page 182
- [Configuring Dual-Serial Link I/O on Linux Workstations](#) on page 184

About Clip Input and Output Using a VTR

Inputting and outputting clips using various VTR devices is the most common means of handling AV material. Flame allows you to perform numerous VTR-based clip input and output operations in a fast and efficient manner. You can capture individual clips or frames, or log clips for capture using an EDL. To learn about the complete EDL conforming process, see [Importing EDL Files](#) on page 321 and [Exporting EDLs](#) on page 393. Similarly, the application allows you to output single clips or frames, as well as multiple clips to a VTR device.

Clip input and output general workflow:

- 1 Make sure all hardware devices involved in the clip input and output process are properly configured. See [Configuring Hardware For Clip Input and Output Using a VTR](#) on page 145.
- 2 Edit the software initialization configuration file to ensure the proper devices and settings are initialized on application start-up. See [Configuring Software For Clip Input and Output Using a VTR](#) on page 145.
- 3 Do one of the following:
 - Input clips. See [Inputting Clips From a VTR](#) on page 146.
 - Output clips. See [Outputting Clips To a VTR](#) on page 153.

NOTE If you want to input or output clips using a live video signal, see also [Inputting and Outputting a Live Video Signal](#) on page 163.

- 4 Carry out additional required procedures, depending on the clip input and output operations that you perform. See:
 - [Adjusting Audio Gain on Clip Output](#) on page 174
 - [Setting Video Input and Output Engineering Menu Controls](#) on page 175

Configuring Hardware For Clip Input and Output Using a VTR

When preparing for a clip input and output session, confirm the following:

- Audio and video outputs of the VTR are connected to the audio and video inputs of the Flame system. Audio and video inputs of the VTR are connected to the audio and video outputs of the Flame system.
- The VTR is connected, using an RS-422 video I/O control cable, to a serial port of your workstation to enable remote control of the device.
- A video sync signal is connected to the sync input of the video device to ensure frame-accurate capture. If there is a separate audio device, an audio sync signal must be connected to it as well.

Video hardware configuration procedures are detailed in the “Setting Up Video Hardware” chapter of the *Autodesk Visual Effects and Finishing Hardware Setup Guide* for your workstation.

Configuring Software For Clip Input and Output Using a VTR

Software configuration in preparation for clip input and output session involves editing the software initialisation configuration file. The procedures for enabling devices in the software initialization configuration file are described in the “Configuration Files” and “Configuration Keywords” chapters of the *Autodesk Visual Effects and Finishing Configuration File Reference Guide*.

When you are preparing for a clip input and output session, consult the software initialization configuration file to confirm the following keyword sections are uncommented and properly configured:

- VIDEO KEYWORD
You do not need to specify the default video I/O timing. The initial timing corresponds to the default resolution and frame rate of the project that you select on start-up. If you select a film or custom resolution for your project on start-up, video I/O timing corresponds to the resolution that was selected as the preferred resolution when the application was installed.
- VTR KEYWORD
You must assign a specific VTR timing, such as NTSC, PAL, or 1920x1080_5994i. Multi-format video input and output capability of your

system allows you to modify the VTR timing, without exiting the project, to any timing supported by your system's video board.

If you plan to perform input and output operations using a live video signal from a broadcast feed or from a device that does not support remote control functionality using RS-422 interface, such as a VCR or camcorder, uncomment the corresponding Live video keyword at the bottom of the SD DECKS section.

NOTE When working in HD projects and capturing material from a Varicam (variable frame rate 720p material), ensure that the following VTR tokens are enabled: (1) *VTR DVCPProHD 720 59p, SERIAL1, 1280x720_5994P* (2) *VTR DVCPProHD 720 60p, SERIAL1, 1280x720_60p*.

Inputting Clips From a VTR

Once you have set up your hardware devices and configured the software initialization file, you are ready to perform clip input and output. The Input Clip menu contains various controls to help you perform operations, such as capturing a single frame, capturing a single clip, capturing and logging multiple clips.

Accessing the Input Clip Menu

Use the Input Clip menu to adjust the settings for the clip you want to input. You can access the Input Clip menu from the Library menu on the desktop.

To access the Input Clip menu from the Desktop:

- 1 In the Main menu, click Library (or press **1**).
- 2 Click Input Clip.



- Click in a destination reel where you want the clips to be captured.
The Input Clip menu appears.

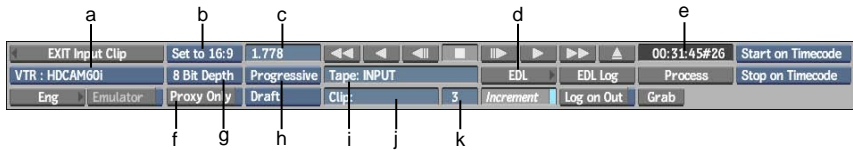

- (a) Device Name box (b) Aspect Ratio box (c) Aspect Ratio field (d) EDL button
(e) Current Timecode field (f) Proxy Quality box (g) Bit Depth box (h) Scan mode box
(i) Tape Name field (j) Clip Name field (k) Increment Name field

Input Clip Menu Options

The basic Clip Input controls are described as follows.

Device Name box Provides an option for each uncommented VTR keyword line in the software initialization configuration file. Select the option that corresponds to the VTR you want to input clips from.

Aspect Ratio box Determines the aspect ratio of the clip you want to capture.

Aspect Ratio field Enter a custom aspect ratio, if the ratio you want to use is not among the options in the Aspect Ratio box.

Bit Depth box Provides the option of capturing clips at a frame depth of 8 or 10 bits per channel, depending on the project you are working with.

Scan Mode box Determines the scan mode metadata tags of the clips created on input. In most cases, you should select the option that matches the format you are capturing. All workstations provide Progressive, Field 1, and Field 2 options.

Engineering button Click to view the clip input and output Engineering menu. See [Setting Video Input and Output Engineering Menu Controls](#) on page 175.

Proxy Only button Provides the option of capturing proxies only.

Proxy Quality box Proxies generated during capture are always of draft quality. Using the Proxy Quality box, you can set the default quality for proxy generation after capture.

Select:	To:
Draft	Generate proxies in the least amount of processing time, at the expense of proxy quality. This is the default setting for proxy generation following video I/O.
Coarse	Get better results than Draft, in more processing time.
Medium	Get better results than Coarse, in more processing time.
Quality	Get the best results, in more processing time than Medium.
Bicubic	Often get good results, usually faster than Quality. Results are likely not as good as Quality, but acceptable.

The previous two controls appear only if the current project is configured, in the Project Setup menu, to store proxies. See [Setting Proxy Management Options](#) on page 532.

Process button Click to start clip input.

Grab button Click to grab the current frame. See [Capturing Single Frames](#) on page 151.

EDL Log button Click to log clip to EDL.

EDL button Click to view the EDL menu. See [Capturing Clips Using an EDL](#) on page 380.

Log On Out button Enable to log EDL events every time you enter an out-point. See [Outputting Multiple Clips](#) on page 158.

Tape Name field Enter the name of the tape from which you are capturing. This step is important for EDL assembly and media recapture procedures.

Clip Name field Enter the name you want to use for the clip you are capturing.

Increment Name button Enable to append numerical increments to the clip name automatically. For example, enter “My_Clip” in the Clip Name field and then enable Increment Name. The first clip you capture is named “My_Clip-1”, the second is named “My_Clip-2” and so on. You can change the initial numerical increment by entering a number in the field that appears when you enable Increment Name.

Start Mode box Determines the start mode for clip input.

Select:	To:
Start On Pen	Capture starting from the currently displayed frame on the tape. Click Process to activate the start-on-pen trigger.
Start On Timecode	Capture starting from the timecode you enter in the In field. Click Process to start the clip input process.

Stop Mode box Determines the stop mode for clip input.

Select:	To capture until:
Stop On Pen	You click anywhere on the screen.
Stop After Frames	A specific number of frames have been captured. When you select this option, a field appears in which you enter the number of frames you want to capture.
Stop On Timecode	A timecode on the tape has been reached (entered in the Out Timecode field).

Current Timecode field Indicates the current timecode of the tape in the VTR.

In Timecode field Indicates the timecode on the tape at which point the clip output process begins.

Out Timecode field Indicates the timecode on the tape at which point the clip output process ends.

Duration field Indicates the duration, in timecode, between the clip output in-point and out-point.

The following controls are found on the right side of the menu (not shown in preceding illustration).

Tape EE button A status button that, when lit, indicates that the VTR is in E-to-E mode (electronic to electronic). This means that the VTR output is showing its input signal. Clicking Tape EE toggles E-to-E on and off.

Standby button A status button that, when lit, indicates that the VTR is in standby mode. Click Standby to toggle between standby off and standby on.

In/Out Point controls Use to enter, adjust, and cue to clip output in and out points. See [Setting Input and Output In and Out Points](#) on page 162.

VTR Status display Indicates the current status of the VTR. See [Controlling a VTR](#) on page 171.

Selecting a VTR Device For Input

The VTR devices available depend on the VTR keyword lines uncommented in the software initialisation configuration file. Make sure the VTR you select is appropriately connected using the corresponding audio, video, and RS-422 connections.

In certain situations, Flame pre-selects a VTR with appropriate timing for you, as described in [Working with Multi-Format Input and Output](#) on page 164.

To select the VTR device for input:

- 1 From the Device Name box, select an option corresponding to your VTR device.

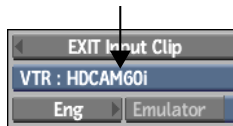

- 2 Make sure the selected device is in Remote mode. See [Controlling a VTR](#) on page 171.

Naming Tapes and Clips

Proper media management is an essential part of the clip input and output process. One of the elements of efficient media management is methodical and consistent naming of the clips you capture and the tapes from which they originate. Before capturing a clip, assign a name to the tape and the resulting clip. This makes it easier to organize your clips, trace them back to the source tape, and, when necessary, recapture them.

To name a tape and clip:

- 1 In the Tape field, enter the tape name.
The tape name is stored with the clip. In the clip library or on the Desktop, you can **Alt**-click the clip to view its information, including the tape name.
- 2 In the Clip field, enter a clip name.

- 3 Enable Increment Name to use the same name for multiple clips captured in sequence. This appends a numerical tag at the end of each clip so you can differentiate them.
- 4 To change the number of the numerical tag for the next clip to be captured, enter a number in the Clip Index field. By default, the increment begins at 1.

Selecting Tracks and Channels to Capture

Whether you are inputting single frames, single clips, multiple clips or conforming EDLs, you must select the tracks and channels you want to capture from the VTR.

To select the tracks and channels to capture:

- 1 To capture the video track, enable V.
- 2 To toggle between audio tracks 1-4 and 5-8, click the Toggle Audio Tracks button.
- 3 To capture audio channels, enable the corresponding channel selection buttons.

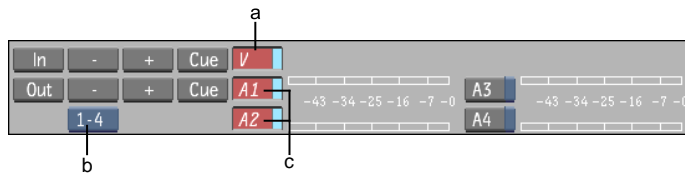

(a) Video track enabled for capture (b) Toggle Audio Tracks button (c) Audio channels 1 and 2 enabled for capture

Audio meters display the gain level being captured. You cannot change this level during capture. You can modify the gain of a clip once capture is complete, as described in [Audio](#) on page 1195.

Capturing Single Frames

A single frame capture, or a frame grab, is the simplest clip input operation. This is useful for extracting snapshot frames for a preview or promotion piece.

To capture a single frame:

- 1 Cue up to the frame you want to capture using the VTR Transport controls or by scrubbing the preview window.
- 2 Click Grab.



The captured frame is saved on the desktop.

- 3 Click EXIT Input Clip to view the captured frame.
- 4 If you want to compare the captured frame against the frame in the preview window, load the clip into the Output Clip menu and enable split-screen view. See [Monitoring Video During Clip Input and Output Operations](#) on page 161.

Capturing Single Clips

You can capture a single clip from a VTR. You can do this on the fly with your in and out points determined by mouse clicks during playback, or be more precise by setting in and out points in the corresponding fields.

To capture a single clip:

- 1 Cue up the tape to the frame at which you want to begin capturing.
- 2 Do one of the following:
 - From the Capture Method box, select Start On Pen/Stop On Pen.
 - Enter clip input in and out points in the In and Out fields. See [Setting Input and Output In and Out Points](#) on page 162.

- 3 To begin capturing, click Process.

The timecode field turns green, indicating that capture is in progress. Depending on your hardware configuration, the preview window may go black during capture.

- 4 To end the capture at any time, click the cursor anywhere over the preview window.

Depending on your project proxy settings, a post-process may occur, generating proxies for each captured frame. You can see a notification on the process that is taking place in the message bar.

Once all capture-related processes are complete, the clip is saved to the desktop. In the Input menu, two buttons appear after capture: Play and Delete. Click Play to view the clip in the Player, and Delete to delete the clip.

Outputting Clips To a VTR

Once you have clips that are ready for output to tape, you can use the Output Clip menu to perform this operation. Similar to capturing, you can output single clips or multiple clips, and enable a split view to preview the clip you want to output alongside the media on the tape simultaneously.

Another way to output multiple clips is to generate an EDL and then output the clips using the EDL.

Most of the procedures in this section assume you have already blacked your tape. However, if necessary, you can output in assemble mode, which allows you to perform clip output to a tape that was only partially blacked. See [Outputting Clips in Assemble Mode](#) on page 160.

For HD-specific considerations, see [Inputting and Outputting HD Material](#) on page 168.

Accessing the Output Clip Menu

Access the Output Clip menu from the Library menu on the desktop. You can select a single clip for output, or a reel containing multiple clips for output.

To access the Output Clip menu:

- 1 From the Main menu, click Library (or press 1).
- 2 Click Output Clip.

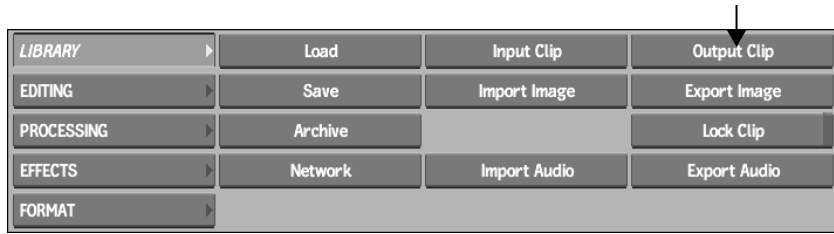

The cursor becomes a red arrow.

3 Do one of the following:

- Click the clip you want to output. If the timing of the clip differs from your current preview timing setting in Preferences, Flame switches to that timing and attempts to select a matching VTR from the list of available devices. See [Working with Multi-Format Input and Output](#) on page 164.
- **Alt-click** a clip on a reel to output all clips on that reel. If the clips have different timing settings, the timing of the first clip selected is respected. Clips having different timing settings from the first clip are ignored.

The In, Out, and Dur fields are set based on the corresponding values of the selected clip.

NOTE If you selected multiple clips and they have overlapping timecode, a message appears indicating that the clips cannot be output. Use the Change TC/KC tool in the Format menu to remove these timecode conflicts. See [About the Change TC/KC/Rate Tools](#) on page 413.

Output Clip Menu Controls

The following illustration and controls descriptions explain the options in the Output Clip menu.



(a) Device Name box (b) Clip Name field (c) Current Timecode field

Device Name box Click to see the list of options for each uncommented VTR keyword line in the software initialisation configuration file. Select the option corresponding to the VTR to which you want to output clips. See [Selecting a VTR Device For Input](#) on page 150.

All Audio button Enable to output all audio channels for monitoring, even if only some audio channels are enabled for recording to tape.

Eng button Click to view the clip input and output Engineering menu. See [Setting Video Input and Output Engineering Menu Controls](#) on page 175.

Process button Click to begin the clip output process.

Preview button Click to trigger a simulation of the output process. The VTR behaves as if it is inserting material, however no material is recorded to tape.

Letterbox button Enable to apply a letterbox overlay on output. See [Outputting Clips With a Letterbox Overlay](#) on page 160.

Split View button Enable to simultaneously monitor the clip selected for output and the content on the tape. See [Monitoring Video During Clip Input and Output Operations](#) on page 161.

Clip Name field Displays the name of the clip selected for output.

Start On Timecode field A locked field indicating that clip output begins at the timecode entered in the In Timecode field.

Stop Mode box Determines the stop mode for clip output.

Select:	To output the current clip until:
Stop On Timecode	A timecode on the tape is reached (indicated in the Out Timecode field).
Stop After Frames	A specified number of frames are output. When you select this option, a field appears in which you enter the number of frames you want to output.

Current Timecode field Indicates the current timecode of the tape in the VTR.

Offset field Indicates the offset, in timecode, by which the selected clip is output. For example, an offset of 00:00:00:05 indicates that the first five frames of the clip to be output are skipped. The first frame to be output is frame 5 of the clip (counting frames from 0).

The following controls are found on the right side of the menu (not shown in preceding illustration).

In Timecode field Indicates the timecode on the tape at which point the clip output process begins.

Out Timecode field Indicates the timecode on the tape at which point the clip output process ends.

Duration field Indicates the duration, in timecode, between the clip output in and out points.

Tape EE button A status button that, when lit, indicates that the VTR is in E-to-E mode (electronic to electronic). This means that the VTR output is showing its input signal. When E-to-E is off, the VTR shows the contents of the tape it contains. Clicking Tape EE toggles E-to-E on and off.

Standby button A status button that, when lit, indicates that the VTR is in standby mode. Click Standby to toggle between standby off and standby on.

In/Out Point controls Use to enter, adjust, and cue to clip output in and out points. See [Setting Input and Output In and Out Points](#) on page 162.

VTR Status display Indicates the current status of the VTR. See [Verifying the VTR Status](#) on page 172.

Selecting a VTR Device For Output

The VTR devices available depend on the VTR keyword lines uncommented in the software initialisation configuration file. Make sure the VTR you select is appropriately connected using the corresponding audio, video, and RS-422 connections.

In certain situations, Flame pre-selects a VTR with appropriate timing when entering the Output clip module, as described in [Working with Multi-Format Input and Output](#) on page 164.

To select the VTR device for output:

- 1 From the Device Name box, select a VTR device.
- 2 Make sure the selected device is in Remote mode. See [Controlling a VTR](#) on page 171.

Outputting a Single Clip

To output a clip to a VTR, load a clip into the Output Clip menu and then set the in and out points for clip output. If required, enable the options to offset

the start frame for output and to apply a letterbox overlay. See [Output Clip Menu Controls](#) on page 154.

If the duration marked by the in and out points that you set for output is greater than the duration of the clip you are outputting, the last frame of the clip is repeated to fill the gap between the end of the clip and the out point of clip output. For example, if you set a clip output in point at 01:00:00:00 and a clip output out point at 01:01:00:00, the clip output process has a duration of one minute. If the clip you are outputting is 30 seconds long, the last 30 seconds of the output result on tape are filled with the last frame of the clip you are outputting.

To output a single clip to a VTR:

- 1 Load the clip that you want to output into the Output Clip menu. See [Accessing the Output Clip Menu](#) on page 153.
- 2 Make sure that the correct video track and audio channel buttons are enabled so that the corresponding video track and audio channels are output to tape.

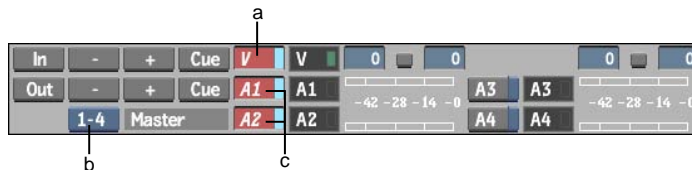

(a) Video track enabled for output (b) Toggle Audio Tracks button (c) Audio channels 1 and 2 enabled for output

- 3 Enable or disable All Audio in the Clip Output menu (to the right of the Exit Output Clip button).

When Output All Audio is enabled, all audio channels (not just the ones corresponding to the audio channel buttons you enabled in the previous step) are sent to the audio converter.

This means you can monitor all audio, even though you are only recording one or two tracks to the VTR. You can also route the other audio channels to a mixer or any other device capable of capturing an audio signal.

- 4 Make sure the appropriate VTR is selected in the Device Name box. See [Selecting a VTR Device For Output](#) on page 156.

The preview window displays the contents of the tape currently in the selected VTR.

- 5 To preview the clip you are outputting against the content on the tape, enable Split View. See [Monitoring Video During Clip Input and Output Operations](#) on page 161.
- 6 To preview the clip before outputting and see its properties, click Play to load the selected clip into the Player.
- 7 To output the selected clip with a letterbox overlay, enable Letterbox and then select the colour and enter values for the letterbox aspect ratio and offset. See [Outputting Clips With a Letterbox Overlay](#) on page 160.
- 8 To output the selected clip starting at any frame other than the first one, enter the start timecode in the Start Offset field.
- 9 Set the in and out points for clip output. See [Setting Input and Output In and Out Points](#) on page 162.
- 10 Click Process to output the clip to the VTR.
- 11 After the transfer is complete, verify that it was successful by playing the transferred clip. To do so, cue to the in timecode and click the Play button in the VTR Transport controls.
- 12 When you are done, click EXIT Output Clip to return to the Desktop reels or clip library.

Outputting Multiple Clips

You can output more than one clip to a VTR in a single pass. When you load multiple clips into the Output Clip menu, you must define the clip output in and out points for each clip (and any other output clip options) before starting the clip output process.

When multiple clips in the same session are selected for output, the application performs a validation check to determine if certain parameters match the project settings and whether or not the video device is capable of outputting these clips. The following outcomes may occur:

- If the clips have mixed timing settings, the timing of the first clip selected is respected. Clips having different timing settings from the first clip are ignored, and a notifying message appears.
- Clips with field dominance mismatch are discarded or kept, depending on your selection.

- Clips exceeding the maximum bit depth are discarded from the selection. A selection containing 8- and 10-bit clips can be output.
- If all the clips are discarded from the selection after the validation check, a notifying message appears allowing you to confirm.

NOTE If clips in your multiple-clip selection have overlapping timecode, a message appears indicating that the clips cannot be output. Use the Change TC/KC tool in the Tools menu to remove these timecode conflicts. See [About the Change TC/KC/Rate Tools](#) on page 413.

To output multiple clips:

- 1 Load multiple clips into the Output Clip menu. See [Accessing the Output Clip Menu](#) on page 153.

When you load multiple clips into the Output Clip menu, additional controls appear.



(a) Move One Clip Left/Right buttons (b) Current Clip field

- 2 To switch from clip to clip, do one of the following:
 - Click the left and right arrows. The Current Clip field indicates the position of the clip relative to the output sequence.
 - Drag over the Current Clip field.
- 3 Set output options for each clip. See [Outputting a Single Clip](#) on page 156.
- 4 Once output options have been set for each clip, make sure you are viewing the first clip in the output sequence.
- 5 Click Process.
- 6 After the transfer is complete, verify that it was successful by playing the transferred clip: cue to the in timecode and click the Play button in the VTR Transport controls.

- 7 When finished, click EXIT Output Clip to return to the Desktop reels or clip library.

Outputting Clips With a Letterbox Overlay

You can apply a letterbox overlay on output. The letterbox does not affect the clip itself; it is applied on the fly as part of the real-time output process.

To output clips with a letterbox overlay:

- 1 In the Output Clip menu, click Letterbox; this enables the Letterbox options.



(b) Letterbox aspect ratio field (c) Letterbox offset field (a) Colour selector box

- 2 Set letterbox options:
 - In the Aspect Ratio field, enter a value to set the aspect ratio of the letterbox overlay.
 - In the Offset field, enter a value to shift the letterbox overlay up or down, as required.
 - Use the colour box to set the colour of the letterbox overlay.

Outputting Clips in Assemble Mode

If you do not have time to black an entire tape, you can black a small portion of the tape and output clips to the tape in assemble mode. In this mode, the timecode on the tape is generated by the VTR as part of the recording process. Make sure that timecode regeneration is properly configured on the VTR. Autodesk recommends blacking one minute at the beginning of the tape.

When outputting a clip in assemble mode, you should extend the duration of the output to avoid problems if you need to recapture the segment. For example, this can be done by adding five to ten seconds of black at the beginning and at the end of the clip, before entering the output clip module.

To output a clip in assemble mode:

- 1 On the VTR, set the TC generator switch to Internal and Regen to make the VTR generate the timecode. Refer to your VTR manual for instructions on setting the TC generator.

TIP If you have just added black to your tape, the VTR should already have these settings.

- 2 Set clip output options. See [Outputting a Single Clip](#) on page 156.
- 3 With the clip you want to output in the Output Clip menu, set the clip output in and out points. See [Setting Input and Output In and Out Points](#) on page 162.
- 4 If black was not added at the end of the clip, make sure the out point exceeds the duration of the clip by five to ten seconds.
- 5 **Ctrl-click** Process to output the clip in assemble mode.

Monitoring Video During Clip Input and Output Operations

When you output a clip to a tape that already has media on it, you can enable a split view to compare a clip with a portion of tape, in much the same way as split view allows to compare two video segments in the player. This can be especially useful if you are outputting a clip to seamlessly overwrite a section on the tape.

To use the split view preview option:

- 1 With a clip or clip(s) loaded in the Output Clip menu and a tape in the appropriate VTR device, enable Split View.



The Split View controls are enabled and you can view the clip that is currently set for output alongside the content on the tape.

- 2 Set Split View preview options:
 - In the Split field, enter a value to set the relative position of the split.

- From the Current Clip Display box, select an option to set the location of the current clip display.
 - From the Split Orientation box, select Horizontal Split or Vertical Split to set the Split View orientation.
- 3 With Split View enabled, you can scrub the VTR to locate the frame that matches the frame of the current clip.
 - 4 Set the In point to the timecode of the frame on tape that corresponds to the first frame of the clip.
 - 5 Cue to the In point. The first frame of the clip and matching frame on tape are displayed in Split View.
 - 6 Click Play to play the tape and the clip simultaneously in Split View.
 - 7 Click Stop, and disable Split View when you are finished.

Setting Input and Output In and Out Points

You can enter timecode values directly in the In, Out, and Dur fields to set in and out points for clip input and output. However, there are other methods of setting the in and out points that are more convenient if you are scrubbing the tape in the VTR to locate reference frames for clip input and output. For example, if you output a clip to overwrite a segment on a tape, you scrub the tape to locate the frame that matches the first frame of the clip you are outputting.

You can also enter in and out points, as well as duration values based on the timecode value of a clip selected for input. Simply click Input Clip, then while holding down the left **Ctrl** key, select a clip and a destination reel.

Besides the described methods of entering timecodes in the In, Out, and Dur fields, you can modify clip in and out points or cue the VTR to these points using the following controls on the right side of the Input or Output menu.

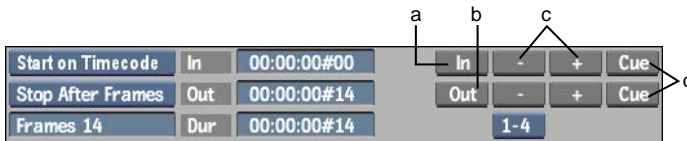

(a) In button (b) Out button (c) + and - buttons (d) Cue buttons

In button Click to set the In field to the VTR's current timecode.

Out button Click to set the Out field to the VTR's current timecode.

+ and - buttons Click to frame-step the In or Out timecodes forward or backward. If Stop After Frames is selected from the Stop Mode box, both the in and out points move because the duration between them is locked.

Cue buttons Click to cue the VTR to the in or out point.

Inputting and Outputting a Live Video Signal

If you uncomment a Live Video VTR keyword you can capture a live video signal or crash-record a clip using the pen to start and stop the clip input or output process.

On input, use the Live NTSC or PAL option to capture directly from a camera, VCR, or any other device that does not support remote control via RS-422. You can also feed a live video signal from satellite or any other broadcast source.

On output, use the Live Video option to output clips to a device that does not support remote control via RS-422.

To input a live video signal:

- 1 Enter the Input Clip menu.
- 2 From the VTR Device box, select Live Video.

The incoming live video signal appears in the preview window. The Start Mode and Stop Mode boxes are disabled. With Live Video, you must use Start On Pen and Stop On Pen capture mode.

Start on Pen	In	00:00:00:00
Stop on Pen	Out	04:00:00:00
	Dur	04:00:00:00

NOTE When Stop On Pen is selected as the preferred capture stop mode, the out point and the duration timecode fields are updated to reflect the longest possible duration corresponding to the full capacity of a framestore. The capture stops either when you click anywhere on the screen or the timecode indicated is reached, meaning that the framestore is full.

- 3 Set input options. For example, enter the clip name and enable the video tracks and audio channels that you want to capture. See [Inputting Clips From a VTR](#) on page 146.

- 4 Make sure you are receiving the live video signal.
- 5 If you are capturing from a device that does not support remote control, press Play (allowing enough time to click Process in Flame).
- 6 To begin capturing, click Process.
After a moment, you are prompted to click anywhere to begin the output process.
- 7 Click anywhere on the screen.
- 8 To end capturing at any time, click anywhere on the screen.

To output a live video signal:

- 1 Load a clip into the Output Clip menu.
- 2 From the VTR Device box, select Live Video.
The Start Mode and Stop Mode boxes are disabled. With Live Video, you must use the Start On Pen and Stop On Pen capture mode.
- 3 Set output options. For example, enter the clip name and enable the video tracks and audio channels that you want to capture. See [Outputting Clips To a VTR](#) on page 153.
- 4 If you are outputting to a device, click Record, or take any action required to enable the device capture the signal being output from Flame.
- 5 To begin capturing, click Process.
After a moment, you are prompted to click anywhere to begin the output process.
- 6 Click anywhere on the screen.
- 7 To end capturing, click anywhere on the screen.

Working with Multi-Format Input and Output

The following sections describe important information about working with multi-format video material in Flame projects.

About Working with Multi-Format Input and Output

You can work with clips of any resolution in your project. You can process images of differing resolutions in Flame. The video I/O procedures that you perform to input and output clips to and from Flame using a VTR, as well as capture and assemble EDLs, are not restricted to your project's default resolution. You can input and output clips of another video resolution to and from your project.

Keep track of the different resolutions and video standards to which your clips belong to make it easier to work in the mixed resolution environment of Flame. Enable clip information display on the Desktop and in the clip library to identify clip resolution and framerate at a glance. See [Clips](#) on page 849.

On start-up, when you select or create a user and a project, you set the video I/O timing for your project (for example, NTSC or PAL). If you are in a session and you want to change the video I/O timing option set at start-up, you can do so without exiting Flame by selecting the required timing from the VTR Timing box, provided this timing is supported by your video board.

You can also change the preview timing in the Preferences menu. The preview timing in the Preferences menu is linked to the Clip Input and Output menus. In other words, when you change preview timing in the Preferences menu, the change is reflected in the Clip Input and Output menus. This lasts for the duration of the current session, or until you change the preview timing again.

To be able to output to a VTR that has the timing that matches your new project timing, you need to change the corresponding audio, video, and RS-422 connections to the VTR. See [Configuring Hardware For Clip Input and Output Using a VTR](#) on page 145.

Flame Detection of Sync and Timing

In the following circumstances, Flame checks whether or not your incoming sync matches the project timing you are working on:

- When you load a project on start-up
- When you change projects in the Preferences menu
- When you change preview timing in the Preferences menu
- When you change your VTR to one with a different timing, or change the timing on your VTR

If your video sync is correct, you can proceed as expected. If it does not match, you are prompted to fix the sync and click Confirm. One of the following occurs:

- If you click Confirm without fixing the sync, the check is done again and you are not allowed to proceed.
- If you click outside of the Confirm button, you proceed in “free-run” mode. You can work in this mode, but input and output can have unpredictable results, and no more sync checks are done.
- If you fix the sync and click Confirm, you can proceed as expected.

When changing project timing, Flame selects an appropriate VTR for you. The VTR devices available depend on the VTR keyword lines uncommented in the software initialisation configuration file. If multiple VTR matches are found in the list, Flame selects the first match. If no match is found, VTR selection reverts to "No VTR selected" with the appropriate timing.

You can also manually select a VTR, as described in [Selecting a VTR Device For Input](#) on page 150 and [Selecting a VTR Device For Output](#) on page 156.

Changing Resolutions for Clip Input or Output

The following steps describe how to change resolution and timing when performing clip inputs or outputs.

NOTE If you are outputting a clip whose timing differs from the preview timing setting in the Preferences menu, the timing and VTR switch are done automatically by Flame as soon as you select the clip to open the Clip Output menu.

To switch from one resolution to another for clip input and output:

- 1 In the Clip Input or Clip Output menu, select the required VTR from the Device Name box.



When you select a VTR, the current preview timing for the project switches to correspond to the VTR, if necessary.

- 2 Change the hardware connections and sync reference to match the resolution that you have chosen. If using a broadcast monitor, connect a valid signal to a reference input to enable a video preview.

Once the input or output is done and you close the menu, you are reminded that the preview timing for the project has changed.

Things to Remember

When working with multi-format video material in the same session, consider the following:

- You set the default timing for your project when you assign it the resolution and frame rate at the time of creation.
- Even if a project has a specific timing (resolution and framerate), it can contain clips of various resolutions.
- You can input clips from any device supported by your system's video board, but clips are captured at their native device-based resolution and format.
- You can output clips to any device supported by your video board, but clips selected for output must be of the resolution and format that correspond to the video timing of the device.
- You can change the video timing of your VTR device without exiting your session, but to output to a VTR of this timing, you must also change the corresponding hardware connections.
- The preview timing in the Preferences menu is linked to the Clip Input and Output menus. In other words, when you change preview timing in the Preferences menu, the change is reflected in the Clip Input and Output menus.
- Flame checks if your video sync matches the timing of the material you are working on when you load a project on start-up, change projects in the Preferences menu, change preview timing in the Preferences menu, or select an output clip.
- When a project is loaded or timing is changed, Flame selects an appropriate VTR for you, if necessary. The VTR devices available depend on the VTR keyword lines uncommented in the software initialisation configuration file.

Inputting and Outputting HD Material

On HD-capable workstations, you can uncomment HD VTR keywords and perform real-time HD clip input and output.

You can input and output clips in the following HD formats.

Format	Resolution	Scanning	Supported Frame Rates
720p	1280 x 720	Progressive	50, 59.94, and 60 fps, Hz
1080i	1920 x 1080	Interlaced	25, 29.97, and 30 fps, Hz
1080p	1920 x 1080	Progressive	23.976, 24 and 25 fps, Hz
1080PsF	1920 x 1080	Progressive	23.976, 24 and 25 fps, Hz

Generating Proxies

With sufficient processing power, proxies are generated in real time. Otherwise, this occurs as a post-process. To achieve better performance, or to use higher quality proxy types, you might want to perform clip input without proxy generation, then edit project settings to generate proxies overnight.

The following guidelines refer to working on HD projects set to generate proxies.

On HD-capable workstations, you may create projects with proxy management options set to generate proxies for HD clips. If your hardware configuration supports on-the-fly proxy generation, your clips are captured and proxies are generated as part of the real-time input process. Otherwise, you may be required to wait for proxy generation once the capture process itself is complete.

If you are capturing many clips one-at-a-time, you may want to turn off proxy generation for you project. That way, you can capture your clips without having to wait for proxy generation.

Once you have completed the capture process, turn proxy generation back on. If you have captured many clips, this process could take a long time. You may want to do this when you can leave the workstation unattended, for example, overnight.

Capturing Proxies Only

On HD-capable workstations, you may create projects with proxy management options set to generate proxies for HD clips. One finishing or digital intermediate workflow is to capture HD video and then unlink the high-resolution media. This workflow provides lower-resolution media that you can interact with more quickly while creating effects and editing sequences. Once your effects and sequences are complete, you relink the high-resolution media so you can output your high-resolution masters. See [Unlinking and Relinking Media and Clips](#) on page 269.

Rather than capturing high-resolution media, generating proxies, and then unlinking the high-resolution media, you can capture only proxies. In this case, the high-resolution media is captured, proxies are generated, but the high-resolution media is discarded. As a result, much less space is required on the framestore.

You work with the proxies to do most of your creative work, such as visual effects and edit sequences. When they are complete, you recapture the media so you can output the masters. Some creative procedures, however, such as colour correction, cannot be reliably completed using only a proxy reference. You need full resolution clips to successfully finish these tasks.

To capture proxies only:

- 1 Open the Input Clip menu.
- 2 Enable Proxy Only.

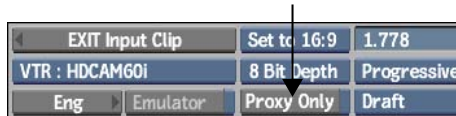

If your proxies are set to be generated as a post process, you can see an estimated time required for proxies generation in the message bar. You can abort this process at any time by clicking anywhere on the screen. When you click the screen, a message appears asking you to confirm the operation. Only the captured media that corresponds to completed proxy generation is preserved. Any captured frames for which no proxies have been generated are purged.

Capturing Material with Variable Frame Rate

To perform frame-accurate video input and output using Panasonic® variable frame rate VTR decks, you must use the following firmware versions:

- AJ-HD3700H D5-HD deck:
SYSCON: 1.04 or later
AV: 0.21 or later
FRONT: 0.13 or later
- AJ-HD1200A DVCPRO HD deck:
SYSIF: 1.30 or later
AVDV: 1.39 or later
SERVO: 1.22 or later

Regular video input and output is not affected by a firmware version.

NOTE Refer to your Panasonic documentation for information on verifying the firmware version.

To capture material from a Varicam device:

- 1 Ensure your devices are properly connected and the corresponding VTR keywords are enabled in the software initialization configuration file. See [Configuring Software For Clip Input and Output Using a VTR](#) on page 145.
- 2 Open the Input Clip menu. See [Accessing the Input Clip Menu](#) on page 146.
- 3 From the Device Name box, select a video device, supporting variable frame rate (for example, one of the following options: VTR DVCProHD 720 59p or VTR DVCProHD 720 60p).



- 4 Enter the Engineering menu and enable Varicam (on the right side).



- 5 Make sure the Video Input Delay is set to zero or a positive value (negative video input delay is not supported on Varicam capture).
- 6 From the Timecode Mode box, select the required timecode.

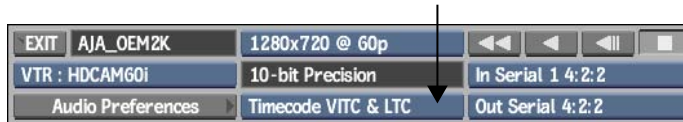

- 7 Exit the Engineering menu and click Process.

Flame removes the redundant frames so that the frame rate of the captured clip corresponds to the frame rate of the project. You can monitor the process using the VTR Status display. The Current Frame Rate field is updated depending on the frame rate of the captured material.

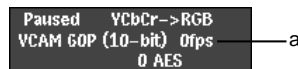

(a) Current Frame Rate field

NOTE When performing operations in Varicam mode, audio/video synchronization largely depends on frame rate compatibility and can be guaranteed only if the following conditions are observed: (1) *Material shot at 24 fps and captured into a 24 fps project* (2) *Material shot at 30 fps and captured into a 30 fps project* (3) *Material shot at 60 fps and captured into a 60 fps project.*

Controlling a VTR

The RS-422 serial connection between the VTR and your workstation enables full remote control of the device from Flame. Connected VTR devices send their current status to Flame, and this status is displayed in the Input Clip and Output Clip menus.

Verifying the VTR Status

The following illustration shows a VTR status display.

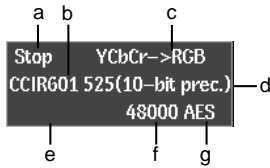

(a) VTR Status (b) VTR Timing (c) Colourspace (d) Bit Precision (e) Control Mode
(f) Audio Sample Rate (g) Audio Input/Output Type

Other VTR status values include:

VTR field:	Indicates:
VTR Status	Play, Play Lock, Stop, Jog, Fast Forward (FFW), Rewind (RWD), 3x, 4x, 8x, 15x, 30x. When the field is blank the VTR is disengaged.
VTR Timing	The video timing currently configured on the video device
Colourspace	The colourspace conversion method for both input and output of clips.
Control Mode (LOCAL, REMOTE, or REC INHIBIT)	Whether the VTR is in Local or Remote control mode. Local appears in yellow when the VTR is in Local mode. In Local mode, the VTR cannot be controlled from Flame. You can switch the VTR between Local and Remote mode only on the VTR. Rec Inhibit implies REMOTE mode, but you cannot output to the tape.
Audio Sample Rate	The audio sampling rate when you input or output from the VTR.
Audio Input/Output Type	The source audio interface type when inputting and the destination audio interface type when outputting.
Bit Precision	The accuracy used (SDI bit depth) when transferring data. This cannot be changed.

Using the VTR Transport Controls

The current frame on the cassette in the VTR appears in the image window and the Current Timecode field (the uppermost timecode field in the Clip Input and Output menus) displays the timecode of the current frame.



(a) Current Timecode field

Use the following VTR Transport controls to play the VTR.

NOTE The VTR must be in Remote mode to use the VTR Transport controls.

Click:	To:	Hot Key:
	Rewind the tape.	Home
	Play the tape backward.	-
	Move backward one frame. Hold down to slowly jog backward.	left arrow key (down arrow key for -5 frames)
	Stop the tape.	spacebar
	Move forward one frame. Hold down to slowly jog forward.	right arrow key (up arrow key for +5 frames)
	Play the tape forward.	Enter
	Fast-forward the tape.	End
	Eject the tape.	none

You can also shuttle the VTR by dragging the cursor in the image window. Place the cursor on the image, press the pen or mouse button, and drag the cursor to the right to shuttle forward and to the left to shuttle backward. The farther away you move the cursor horizontally from the middle of the image, the faster the speed.

You can also change the reverse or forward playback speed by pressing the **Up** or **Down arrow Keys** on your keyboard. Each press reduces or increases the speed by two.

Adjusting Audio Gain on Clip Output

Audio gain adjustment is a part of the clip output process only. The clips you are outputting are unaffected by audio gain adjustments made using the Output Clip menu.

On output, you can adjust the audio gain, for example, to restore the levels you had monitored on capture.

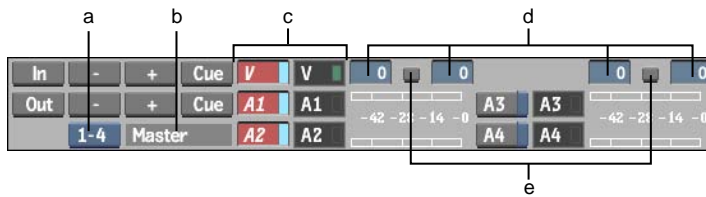

(a) Toggle Audio Tracks button (b) Audio Signal field (c) Channel Selection buttons and indicators (d) Audio Level fields (e) Fader Lock buttons

Toggle Audio Tracks button Toggle between audio tracks 1-4 and 5-8.

Audio Signal field Displays which audio signal is being monitored on output. This is set in the Audiodesk.

If the following is displayed: **Then the following signal is being monitored:**

Monitor Audio on the tape to which you are outputting.

Master Audio on the clip you are outputting.

Channel Selection buttons and indicators Control and display which audio channels are input or output. The black boxes with the green LEDs indicate video tracks and audio channels that are part of the master clip that you want to output. The red buttons indicate the tracks and channels enabled to be output.

Audio Level fields Used to change the audio gain, in decibels. Increase or decrease the gain by dragging left or right on the fields. By default, audio gain is 0 db.

Fader Lock buttons When enabled, locks the faders for the corresponding pair of audio channels together.

To adjust the audio gain on clip output:

- 1 Using the Output Faders box, switch between the Monitor Faders and Master Faders. When previewing or processing a clip, the Master Outputs faders are automatically selected.
- 2 Enable the Fader Lock buttons (so that they are light grey) if you want to apply the identical value to pairs of audio channels.
- 3 Slide the faders to adjust the audio gain before you start processing. Use the Monitor faders to adjust audio gain for the tracks you are monitoring from the VTR. Use the Master Faders option to adjust the audio gain for the channels of the clip you are outputting.

NOTE Only changes applied with Master Faders affect the audio gain levels of the clip that is output.

- 4 In the Clip Output menu, enable Output All Audio.
- 5 Select or deselect channels for output by clicking the Channel Selection button for each channel as needed.

NOTE In a multiple clip selection, channel selection is independent for each clip but the gain levels set with the faders are the same for all clips.

- 6 Process the clip.
Selected channels are output. If you used the Master Faders option, the changes to audio gain are reflected in the output clip.

Setting Video Input and Output Engineering Menu Controls

Clip input and output engineering options include video I/O settings such as pre-roll, post-roll, play delay, colourspace conversion, and settings that define the process by which YUV video material on a tape is converted to the RGB format used by Flame, and vice-versa.

Each VTR device is associated with a set of default engineering settings that are specified in the software initialisation configuration file, in the VTR KEYWORD section.

When you start Flame and set the video I/O timing for your project, uncommented VTR devices are initialized, and the settings in the Engineering menu are populated accordingly. However, if necessary, you can modify these settings on a session-to-session basis.

To change the default Engineering menu settings for a VTR device, you must edit the software initialisation configuration file. See the *Autodesk Visual Effects and Finishing Configuration File Reference Guide*.

To open the Engineering menu:

- 1 From the Input Clip or Output Clip menu, click Eng.



Consult the following illustration (broken into three parts) and explanations of the options in the Engineering menu.

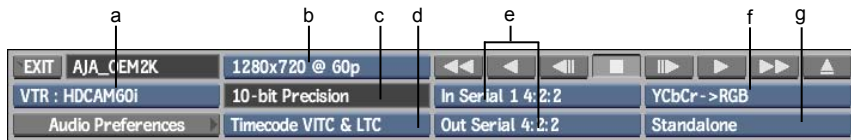

(a) Device Name box (b) Video I/O Timing box (c) Precision box (d) Timecode Source box (e) Input and Output Connection boxes (f) Colourspace box (g) Output Sync box



(h) VTR Current Timecode field (i) PreRoll/PostRoll fields (j) Cue Up box (k) Error Retry field (l) Proxy Box

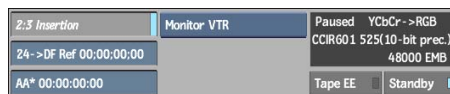

Device name box Provides an option for each uncommented VTR keyword line in the software initialisation configuration file. To modify settings for a specific VTR device, select the corresponding option from this box.

Video I/O Timing box Provides video timing options (resolution and frame rate) corresponding to different video formats supported by the video input/output board of the system.

Precision box Determines the video interface precision, or SDI bit depth used. This value cannot be changed.

Audio Preferences button Click to view the Audio Preferences menu. See [Audio Preferences](#) on page 853.

Timecode Source box Determines which type of timecode is obtained from the VTR device.

Select:	To obtain:
Timecode VITC	Vertical interval timecode (VITC).
Timecode LTC	Longitudinal timecode (LTC)
Timecode VITC & LTC	Both types of timecode. At normal playback speed, Flame obtains LTC, but switched to VITC when the tape is rewinding, fast-forwarding, or otherwise moving at a non-playback speed.

Timecode VITC & LTC is the default, and recommended option. You should only have to switch to Timecode VITC or Timecode LTC if one of the timecode tracks is corrupted.

Input and Output Connection boxes Determines the connection by which the video signal is transferred. These boxes are locked to In Serial 4:2:2 and Out Serial 4:2:2.

Colourspace box Determines the YCrCb colourspace conversion method. See [Inputting and Outputting with Headroom](#) on page 180.

Select:	To perform clip I/O with:
YCrCb->RGB	A standard YCrCb-RGB conversion process that clips superblack and superwhite luma (Y). Use this option for typical clip I/O processes with VTR devices.
YCrCb->RGB + Headroom	A YCrCb-RGB conversion process that preserves superblack and superwhite colour information. Use this option when inputting or outputting greyscale mattes or other clips where preserving extremes in the luma channel is required.
No Conversion	This is available when using dual link for RGB input and output. Video black and white levels on the SDI stream are mapped to black

Select:	To perform clip I/O with:
	and white values in RGB on the framestore. See Inputting and Outputting with Headroom on page 180. Use this option in conjunction with 4:2:2 input and output connections to input and output 4:4:4 video in two passes (4:2:2 and 0:2:2). Third-party sparks (in Smoke, Inferno, Flame) are required to split and merge the 4:2:2 and 0:2:2 clips.
No Conversion + Headroom	Also available when using dual link for RGB input and output. This mode uses all levels available and preserves all but a few RGB values. See Inputting and Outputting with Headroom on page 180. Use this option with the 4:4:4 input and output connections to input clips from and output clips to a Telecine.

Output Sync box Determines the output sync reference source. The reference signal may originate from several different sources. Select the source you are using from this box according to the following table.

Source type	Available on:	Description:
House	All systems	A centralized analogue reference signal, originating from a sync generator, sent to the genlock port on the video board or VBOB.
House Tri-level	IBM® 6224 and 6217 dual-core	Same as house, but using tri-level sync.
Digital	IBM 6217 single-core, IBM 6224 and 6217 dual-core	The digital video signal connected to the video input of the video board.
Digital 1 and Digital 2	Most HP 8400s and all HP 8600s and 9400s	Same as Digital, except you can choose between two inputs: Digital 1 or Digital 2. On the HP 8400 with the AJA SD (OEM-LH) video board, only Digital 1 is available.
Standalone	All systems	The reference signal generated internally by the Flame workstation.

PreRoll field Indicates the pre-roll, in frames.

PostRoll field Indicates the post-roll, in frames.

Video Input Delay field Indicates the video delay on input, in frames. If this value is incorrect, the result clip when you click Frame Grab in the Input Clip menu does not match the frame you see in the preview window.

Video Output Delay field Indicates the video delay on output, in frames. If this value is incorrect, the clip you output does not get recorded to the proper place on the tape.

Audio Input Delay field Indicates the video delay on input, in frames.

Audio Output Delay field Indicates the video delay on output, in frames.

Stop VTR on EXIT button When enabled, sends a stop command to the VTR when you exit the Input Clip, Output Clip, Auto-Capture, or Archiving menu. For example, if the VTR is playing a clip, or if it is cueing to an in point, the transport operation in-progress is interrupted.

Cue Up box Determines the speed of the cueing process.

Select:	To cue up the VTR:
Cue Up VTR	Using the internal cueing algorithm of the VTR.
Cue Up Fast Forward	Using Flame. Use this option if Cue Up VTR is too slow for far cue points, such as on the betacam SP.

Error Retry field Indicates the number of times Flame retries failed input or output processes.

2:3 Removal/Insertion button Enables automatic, real-time 2:3 removal on output and insertion on input. This is only available when the VTR is set to 29.97i or 59.94i.

Proxy box Determines proxy management when inputting clips.

Select:	To generate:
Proxy in Post	Proxies as a post-processing step
Proxy on Capture	Proxies during capture

Generating proxy during capture is the quickest method. Depending on hardware configuration of your system, capture may be performed in real time with playback. Some extra required processing, however, may prevent the graphics board from updating the image window and broadcast monitor in real time, so you may not be able to view the clip being played as it is captured.

Monitor box Set this to Monitor VTR or Monitor Output. In Monitor VTR mode, the signal coming back from the VTR is displayed, and video may appear to be late compared to the audio. In Monitor Output mode, the signal being output to tape is displayed, and the video and audio should be in sync.

Inputting and Outputting with Headroom

With 4:2:2 serial digital interface (SDI) input and output connections, the colour components of video signals are Y (luma), Cb (blue colour difference), and Cr (red colour difference). For standard video signals in 10 bits, black has a luma value of 64 and white has a luma value of 940. When performing standard captures to RGB values on Flame systems, black YCbCr (64,512,512) maps to RGB (0,0,0) and white YCbCr (940,512,512) maps to RGB (1023,1023,1023). SDI values 0 to 3 and 1020 to 1023 are reserved values for synchronization purposes.

Some cameras record shadow details below the video luma black value of 64 and white detail above the video luma white value of 940. These details are called super blacks and super whites. These are also referred to as “headroom” and “footroom.” Under normal circumstances, headroom is not converted during capture, and the super black and super white details are lost, as described in the following illustration:

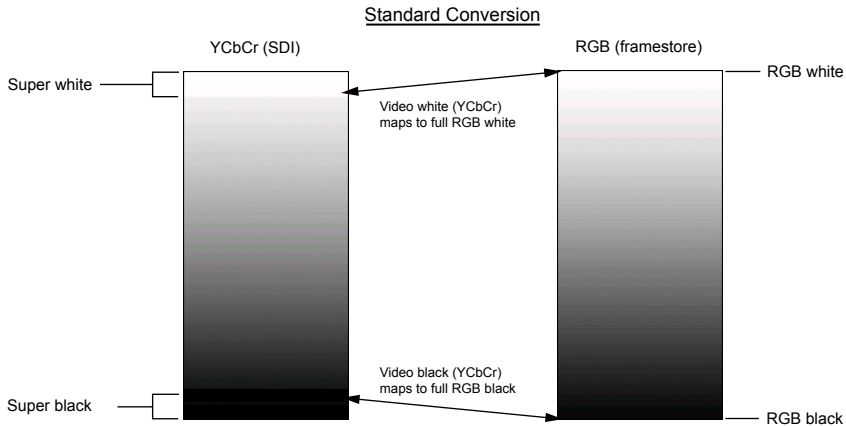

In this illustration, headroom and footroom information is lost.

Using the YCbCr->RGB with headroom colourspace option during input on Flame systems, it is possible to capture these super black and super white values. In this case, video black YCbCr (64,512,512) maps to RGB (64,64,64) in 10 bits, and video white YCbCr (940,512,512) maps to RGB (940,940,940).

YCbCr Luma values between 4 and 64 and between 940 and 1019 are converted to RGB on capture. While this gives you the advantage of being able to capture super black and super white values, it also means that video black will not map to full black in RGB, and video white will not map to full white in RGB. The following image illustrates this:

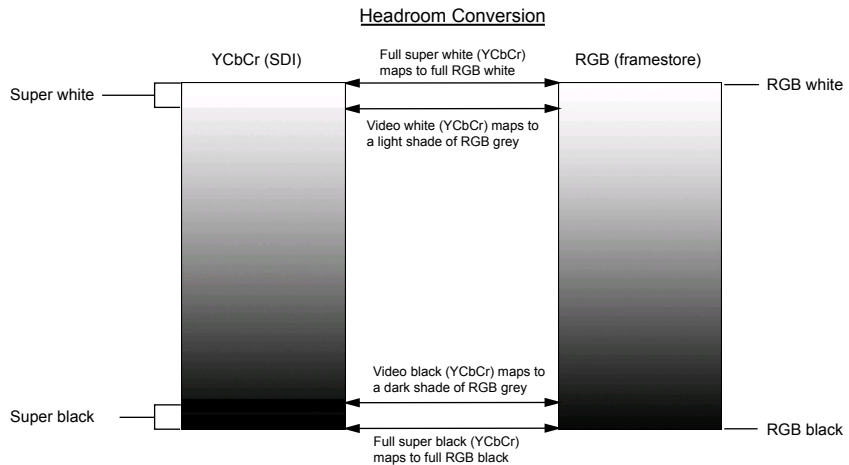

For 4:4:4 RGB standard input and output, a similar explanation applies. On capture using the No Conversion setting, RGB 4:4:4 SDI video black at value (64,64,64) maps to RGB (0,0,0), and RGB 4:4:4 SDI video white at value (940,940,940) maps to RGB (1023,1023,1023).

With the No Conversion with Headroom option, the maximum possible SDI value range is used. RGB 4:4:4 SDI values ranging from (4,4,4) to (1019,1019,1019) map to the same RGB range on capture.

Although the preceding descriptions relate to capture from SDI to the framestore, the reverse applies when outputting from the framestore to SDI.

To enable colourspace conversion on clip input:

- 1 In the Input Clip menu, click Engineering.
The Engineering menu appears.



(a) Input Connection box (b) Colourspace box

- 2 From the Input Connection box, select the input connection.
- 3 From the Colourspace box, select YCbCr->RGB+Headroom.
- 4 Capture the material.
Material is captured with headroom and footroom.

To enable colourspace conversion on clip output:

- 1 Open the clip library with the clip(s) you want to output.
- 2 Click Output Clip and prepare output clip settings. See [Outputting Clips To a VTR](#) on page 153.
- 3 In the Output Clip menu, click Engineering.
- 4 In the Engineering menu, select the output connection from the Output Connection box.
- 5 From the Colourspace box, select YCbCr->RGB+Headroom.
- 6 Output the material.
Material is output with headroom and footroom.

Capturing 60i Material with 2:3 Pulldown Removal

Using the Input Clip menu, you can capture 30 fps film-based material and convert it to 24 fps material in real-time as you capture. The procedure for enabling automatic 2:3 removal differs depending on whether your tape uses non-drop or drop 60i timecode.

To capture 60i material with 2:3 pulldown removal:

- 1 Set up your capture as described in [Inputting Clips From a VTR](#) on page 146.
- 2 In the Input Clip menu, click Eng.

The Engineering menu appears. It contains options for removing 2:3 pulldown in real time while capturing.

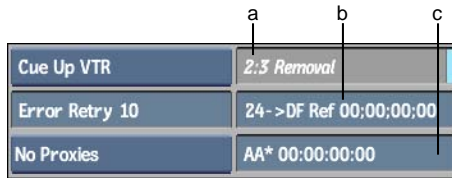

(a) 2:3 Removal button (b) 24>DF Reference field (b) AA Reference field

- 3 Enable 2:3 Removal.
- 4 In the AA Reference field, enter a timecode that corresponds with an AA frame on the tape that is currently in the VTR.

TIP To determine an AA frame, frame-step (**right arrow**) the tape and look closely at each frame. In 2:3 pulldown, two jitter frames with field artefacts are followed by three normal frames. The second frame after the two jitter frames is an AA frame.

- 5 When you capture material from a tape that uses 30 fps drop-frame timecode with 2:3 removal enabled, a slight discrepancy between timecodes is introduced due to the reference timecode used to determine the 30 drop frame to 24 timecode conversion. To optimize correspondence between the timecodes, enter the timecode in the 24 >DF Reference field that matches the start reel timecode for the tape.

TIP The start clip timecode can be deduced from the hour-mark of the timecode used by your clips. For example, 1;00;00:00 drop-frame would require a 1;00;00:00 value in the 24p>DF reference field to get a clip starting at 01;00;00+00.

- 6 Make sure the project's field dominance is set to field1. If the project's field dominance is set to field 2, you must switch the field dominance back to field 1. See [Changing the Scan Mode of a Project](#) on page 721.
- 7 Click EXIT to return to the Input Clip menu.
- 8 Using the In and Out timecode fields, set the in and out points for the capture session.

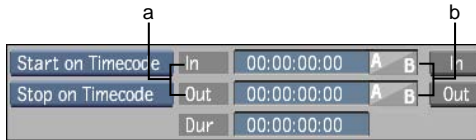

(a) In and Out timecode fields (b) 2:3 In and Out pulldown display

With the in and out timecodes set, the corresponding 2:3 pulldown frame is indicated in the In and Out 2:3 pulldown display. Use the 2:3 Pulldown display to determine the 24 fps result in and out frames.

2:3 Pulldown Frame	24 fps Result Frame
In/Out AA	In/Out A
In/Out BB	In/Out B
In/Out DD	In/Out D
In BC	In C
In CD	In D
Out CD	Out C

- Click Process to capture the material with 2:3 pulldown removal.

For more information on 2:3 pulldown removal, see [2:3 Pulldown](#) on page 703.

Configuring Dual-Serial Link I/O on Linux Workstations

Flame supports dual-serial link input and output connections for 4:4:4 clip I/O on Linux workstations (except for the IBM 6224). Configure the type of I/O connection (single- or dual-link serial) using the Input Connection and Output Connection boxes in the Engineering menu. See [Setting Video Input and Output Engineering Menu Controls](#) on page 175. When you select an input or output connection for clip I/O, you usually also select the colourspace conversion method using the Colourspace box on the Engineering menu. The conversion methods that appear in this box depend on the type of I/O connection used. The following table shows the colourspace conversion

methods that are available for single-link and for dual-link I/O connections on Linux workstations.

Colourspace Conversion Method	Supported for Single-Link Serial (4:2:2) I/O	Supported for Dual-Link Serial (4:4:4) I/O
YCbCR -> RGB	Yes	No
YCbCR -> RGB + Headroom	Yes	No
No Conversion	No	Yes
No Conversion + Headroom	No	Yes

Clip Input/Output Using HSDL Devices

8

Topics in this chapter:

- [About HSDL Input and Output](#) on page 187
- [Setting Up Hardware for HSDL Input and Output](#) on page 188
- [Configuring Software for HSDL Input and Output](#) on page 189
- [Inputting Clips From an HSDL Device](#) on page 189
- [Outputting Clips To an HSDL Device](#) on page 191
- [Setting Video Input and Output Engineering Menu Options](#) on page 191

About HSDL Input and Output

HSDL (High Speed Data Link) is a software-based transport mechanism for moving data between applications. It encapsulates 2K film frames in a video format for transfer. Put another way, HSDL is essentially another video input/output timing, without audio. As a result, the need to read header information for each file is eliminated. Also, frames can pass through most HD devices, such as routers, transparently.

Using HSDL allows you to work on 2K frames in Smoke in collaboration with users on other HSDL-compliant workstations. With transfer rates ranging from 14.99 to 19.13 fps, HSDL I/O represents up to a five-fold increase in transfer

speed versus the Image Import/Export process, using existing infrastructure (assuming your facility is HD-ready). HSDL also enables remote control of the HSDL device connected to your workstation using an RS-422 cable.

Although images transfer as video signals, they are converted to raw RGB data once they arrive at their destination with no loss of information.

HSDL is compliant with the SMPTE 292M HD signal transport mechanisms. Most systems should support HSDL, with the exception of the IBM 6224 and 6217.

Clip input and output using an HSDL device workflow:

- 1 Make sure all hardware devices involved in the HSDL I/O process are properly set up and configured. See [Setting Up Hardware for HSDL Input and Output](#) on page 188.
- 2 Edit the software initialisation configuration file to ensure the proper devices and settings are initialized on application start-up. See [Configuring Software for HSDL Input and Output](#) on page 189.
- 3 Do one of the following:
 - Input clips.
 - Output clips.
- 4 Carry out additional steps, depending on the HSDL I/O process that you are performing.
 - Monitor clips that are being input or output while processing, unless there is no hardware GVO path. See [Monitoring Video During Clip Input and Output Operations](#) on page 161.
 - Generate proxies and parity.
 - Set and modify Engineering menu options.

NOTE Most of these procedures are similar to the ones described in [Clip Input/Output Using a VTR](#) on page 143.

Setting Up Hardware for HSDL Input and Output

Connect the HSDL device using the same method for serial dual RGB 4:4:4 video I/O. To control the HSDL device remotely, connect the device using an RS-422 cable to the serial port on the workstation that corresponds to the port

defined in the software initialisation configuration file. See the *Autodesk Visual Effects and Finishing Configuration File Reference Guide*.

Configuring Software for HSDL Input and Output

Enable the HSDL keywords that correspond to the HSDL device you want to work with.

To enable HSDL keywords:

- 1 In a command shell, type **d1cfg** to open the software configuration initialization file in a text editor.
- 2 Scroll down to the VTR KEYWORD section.
Some HSDL devices are listed at the bottom.
- 3 Uncomment the keywords for the HSDL devices that you want to enable.
- 4 If necessary, edit the serial port definition in each line
(`/dev/tty4d<port#>`) to make sure it corresponds with the serial port that you want to use for RS-422 remote control of the HSDL device.
- 5 Save the file and exit.
You are now ready to start the application.

Inputting Clips From an HSDL Device

Input an HSDL stream of 2K frames as if you were inputting HD video. Use the tools in the Input Clip menu.

To input from an HSDL device:

- 1 On the desktop, click Library (or press **1**) to view the Clip Library menu.
- 2 In the Clip Library menu, click Input Clip.



The Input Clip menu appears.

- From the Device Name box, select the HSDL device.



TIP HSDL device options appear for each uncommented HSDL keyword in the software initialisation configuration file. See [Configuring Software for HSDL Input and Output](#) on page 189.

- Input footage using the controls in the Input Clip menu. Make sure the following settings are entered:
 - 1.316 in the Aspect Ratio field
 - 10-bit Depth in the Bit Depth box
 - Progressive in the Scan Mode box



(a) Bit Depth box (b) Aspect Ratio field (c) Scan Mode box

Audio controls are disabled when using the Input Clip menu to input an HSDL stream. The image that appears is resized to fit the 1920x1080 preview area. This preview resizing does not affect the actual 2048x1556 size of the image being input.

Outputting Clips To an HSDL Device

Output an HSDL stream of 2K frames as if you were outputting HD video. Use the tools in the Output Clip menu.

To output to an HSDL device:

- 1 Make sure the clip you want to output is loaded to the desktop.
- 2 On the desktop, click Library (or press **1**) to view the Library menu.
- 3 Click Output Clip and then select the clip you want to output. The Output Clip menu appears.
- 4 From the Device Name box, select the HSDL device.



TIP HSDL device options appear for each uncommented HSDL keyword in the software initialisation configuration file. See [Configuring Software for HSDL Input and Output](#) on page 189.

- 5 Output the clips using the controls in the Output Clip menu. Audio controls are disabled when using the Output Clip menu to output an HSDL stream. The image that appears is scaled to fit the 1920x1080 preview area. This preview resizing does not affect the actual 2048x1556 size of the image being output.

Setting Video Input and Output Engineering Menu Options

Default values in the Video I/O Engineering menu are defined by the uncommented HSDL keywords in the software initialisation configuration file. See [Configuring Software for HSDL Input and Output](#) on page 189.

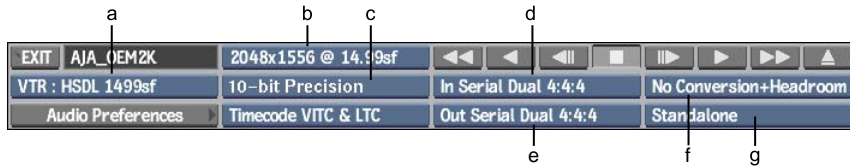

(a) Device Name box (b) Video Timing box (c) Precision box (d) Input Connection box (e) Output Connection box (f) Colourspace box (g) Output Sync box

Engineering Option	Default Value
Video Timing	Can be one of several options, depending on the type of HSDL device used and your operating system. Typical HSDL timings include, but are not limited to, HSDL@14.99, HSDL@15, HSDL@19.13, and HSDL@19.15 fps.
Precision	10-bit Precision
Input Connection	Serial In Dual 4:4:4
Output Connection	Out Serial Dual 4:4:4
Colourspace Box	No Conversion+Headroom
Output Sync	Standalone

Importing Media Files

9

Topics in this chapter:

- [About Importing Media Files](#) on page 193
- [Supported File Formats](#) on page 194
- [About Soft-Import and Proxies](#) on page 199
- [About the Import Image Menu Options](#) on page 201
- [Importing and Soft-Importing Image Files](#) on page 210
- [Importing DPX File Sequences for Data Conform](#) on page 213
- [Importing OpenEXR Files](#) on page 218
- [Importing RGBA Files](#) on page 220
- [Importing Adobe Photoshop Files](#) on page 222
- [Importing and Soft-Importing Video Files](#) on page 224
- [Importing and Soft-Importing in the Background](#) on page 227
- [Importing and Soft-Importing Audio Files](#) on page 229
- [Deleting Media Files From the Filesystem Via Import Image](#) on page 232

About Importing Media Files

At various times during the post-production process, you may need to import files into Flame from other applications. For instance, you may need to import:

- Scanned DPX files generated by a film scanner

- Backgrounds or mattes created in Adobe® Photoshop®, Combustion®, 3ds Max, or other graphic design applications
- Various still image files (for example, TARGA®, JPEG, TIFF)
- QuickTime® video files
- MXF media files
- Audio files (for example, AIFF, MP3, WAV), including music from a CD

You can import and soft-import image or audio files, and import video files. You can add image files or video files to a render queue for batch importing.

You can also import multiple files using EDLs. See [Importing EDL Files](#) on page 321.

Supported File Formats

You can import and soft-import image files using a number of industry-standard file formats. Each file format uses a default file extension. You can use the default extensions as you import and soft-import images.

Supported Image File Formats

Flame supports import and soft-import of the following still image file formats.

NOTE Photoshop files can only be imported. You cannot soft-import Photoshop files.

File Format	Default Extension	Bit Depth
Alias®	als	8 bits
Cineon®	cin	10 bits
DPX	dpx	8, 10, or 12 bits
Jpeg	jpg	8 bits
OpenEXR	exr	8, 10, 12u, 12, 16 fp, or 32 fp bits

File Format	Default Extension	Bit Depth
Photoshop	psd	n/a
Pict (Macintosh)	pict	8 bits
Pixar	picio	8 bits
SGI	sgi	8 or 16 bits
Softimage®	pic	8 bits
TARGA	tga	8 bits
Tdi/Maya®	iff	8 or 16 bits
Tiff	tif	8 or 16 bits
Wavefront®	rla	8 or 16 bits
QuickTime	mov	8 bits
MXF	mxf	8 bits

Supported Audio File Formats

Flame supports import and soft-import of the following audio file formats.

NOTE You can only soft-import the AIFF, AIFF-C, and WAVE audio file formats.

File Format	Default Extension	Bit Depth
AIFF-C	aifc	16, 24, or 32 (float)
AIFF	aiff	16 or 24
Nextsnd	au	16, 24, or 32 (float)
MP3	mp3	16
WAVE	wav	16, 24, or 32 (float)
Broadcast Wave	wav	16, 24, or 32 (float)

File Format	Default Extension	Bit Depth
Berkeley/IRCAM/CARL Sound (BISCF)	bsf	16
Audio Visual Research	avr	16

Supported QuickTime File Codecs

Flame supports import of QuickTime files encoded with any of the following codecs.

NOTE QuickTime PhotoJPEG files can only be imported. You cannot soft-import QuickTime PhotoJPEG files.

Broadcast CODEC	CODEC Flag	Comment
10-bit Packed YUV 4:4:4	v410	
10-bit Packed YUV 4:2:2	v210	Blackmagic or AJA-Kona 10-bit compatible
8-bit Planar YUV 4:4:4	v308	
8-bit Planar YUV 4:4:4:4	v408	
8-bit Packed YUV 4:2:2	yuv2	Blackmagic or AJA-Kona 8-bit compatible
8-bit Packed YUV 4:2:2	2vuy	
DV 25 NTSC	dvc	
DV 25 PAL	dvcp, dvpp	
DVCPRO 50 NTSC	dv5n	Panasonic standard
DVCPRO 50 PAL	dv5p	Panasonic standard
DVCPRO HD	dvh1	Panasonic standard

File CODEC	CODEC Flag	Comment
PhotoJPEG	RTJ0	RT PhotoJPEG compatible
MJPEG	MJPG, mjpg, mjpgb, JPEG, jpeg, dmb1, AVD1	JPEG compatible
PNG	png	Portable Network Graphic sequence (no alpha support)
PNGA	pngalpha	Portable Network Graphic sequence (with alpha support)
RGB Uncompressed	raw	No alpha support
RGBA Uncompressed	rawalpha	With alpha support
TGA	tga	TARGA

Web CODEC	CODEC Flag	Comment
MPEG-1	mpg1, MPG1, pim1, PIM1	
MPEG-4	mp4v; DivX®; DIV1; div1; MP4S;M4S2; m4s2; xvid; XVID; XviD; DX50; dx50; DIVX; MP4V	
MSMpeg 4v3 (DivX)	DIV1, div1, MPG4, mpg4, DIV2, div2, MP42, mp42, DIV3, div3, DIV4, div4, DIV5, div5, DIV6, div6, MPG3, mpg3, MP43, mp43, AP41, ap41, MJPG	
Quicktime Planar RGB	8BPS	
Apple® Video	rpza	
Apple Graphics	smc	
RLE	rle	

Web CODEC	CODEC Flag	Comment
Cinepak	cvid	
<hr/>		
Audio CODEC	CODEC Flag	Comment
IMA 4:1	ima4	
Raw 8-bit audio	rawaudio	
Twos	twos	16-bit PCM (Big Endian)
Ulaw	ulaw	
Sowt	sowt	16-bit PCM (Little Endian)
A-law 2:1	alaw	
16-bit PCM	in16	
Linear PCM (QT 7)	lpcm	
Ogg Vorbis (qt4l compatible)	vorbis	
Ogg Vorbis (qtcomponents compatible)	vorbis_qt	
MPEG-2 Layer 2 Audio	mp2	
QDM2 Audio	qdm2	
Apple lossless	alac	
McRowsoft ADPCM	adpcm (ms)	
ADPCM ima WAV	ima adpcm (wav)	

Supported MXF File Codecs

Flame supports import of MXF files encoded with any of the following codecs.

CODEC	CODEC Flag	Comment
DV 25 NTSC	dvc	
DV 25 PAL	dvcp, dvpp	
DVCPRO 50 NTSC	dv5n	Panasonic standard
DVCPRO 50 PAL	dv5p	Panasonic standard
DVCPRO HD	dvh1	Panasonic standard

About Soft-Import and Proxies

When you *import* media that resides on an external shared storage device, all the media is copied to Autodesk storage. Any changes that you make to this media are protected, and exclusive to this stored copy. However, it can take a long time to load large files and all of this stored media can take up a lot of space in Autodesk storage.

The soft-import feature provides a more efficient way to handle media. When you *soft-import* media, Flame creates a link that references the media at its original location, so that no media is actually imported and duplicated in Autodesk storage. Later, when you move or delete soft-imported clips, you affect only the reference—not the actual media in the shared storage location. If you enabled proxies for the project or media resolution, then only the proxies reside in Autodesk storage.

A *proxy* is a low-resolution copy of a high-resolution image. There can be one proxy for each frame in a clip. Proxies are used to provide real-time playback of processed results and to provide low-resolution stand-in clips in a compositing environment so that composites can be quickly created. Proxies can be configured.

When soft-importing media, be aware that you have no control if another user modifies the original media files. All soft-imported clips in Autodesk storage that refer to the modified media files are updated to reflect the change. Ensure that all users accessing the same media are aware of these implications.

You can render or process soft-imported media in any module. The resulting new clip is written to Autodesk storage. Since any links to the original media are now removed, changes to this media will no longer be updated on the shared storage. Also, if the media changes in the original external location,

the changes are not reflected in your stored clip. This can be useful if you want to prevent other users with access to the shared storage from altering your clip.

You can also soft-import media when importing files using an EDL or recapturing media. See [Importing EDL Files](#) on page 321 and [Recapturing Media](#) on page 280.

Recognizing Soft-Imported Clips

Soft-imported clips on the desktop or in the clip library display an icon in the lower-right corner of the clip. The type of indicator depends on whether the clip is a hybrid clip or a completely soft-imported clip. A hybrid clip has some frames that are soft-imported and some that are not, or it may consist of multiple soft-imported sources of different formats.

Alt-clicking the clip displays an overlay that includes the soft-imported source path.

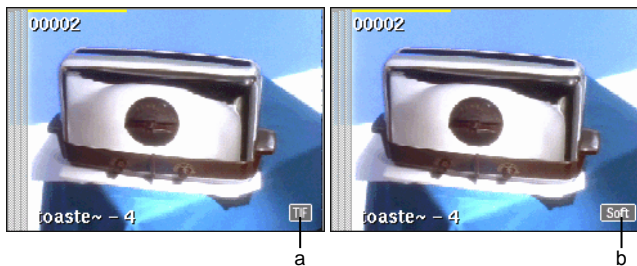

(a) Soft-import icon (for a non-hybrid clip) (b) Soft-import icon (for a hybrid clip)

Image courtesy of Behavior Communications Inc.

Soft-imported clips that do not have associated media appear as white and grey checkered clips.

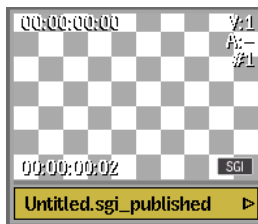

About the Import Image Menu Options

The Import Image menu contains a large number of options that are available for importing graphic image files, film scans, or video files. The menu is divided into six functional groups:

- File Operations
- Clip Media
- Clip Metadata
- Processing
- File Attributes
- Library Operations

For descriptions of additional options in the Import Image menu, see [Navigating the Filesystem](#) on page 82.

File Operations Group

Use these options to perform file input and processing operations.



(a) File Format box (b) File Extension box (c) Add To Queue box (d) Destination Library box

File Format box Select the file format of the images that you want to import. The application uses file metadata to detect its format automatically. Automatic file-type detection makes it easier and faster to set up import queues consisting of different file types. If you select Auto, then all files in the current directory are displayed in the Files list. An alternative way to achieve the same result is

to select the file format and enable Show All in the Files list. However, with Auto selected, you can load or add to the import queue files of any format.

File Extension box Displays the default extension for the file type selected in the File Format box. If the files that you want to import do not use the default extension for the selected file format, they do not appear in the browser. You may enter an extension in the File Extension field to display files using this extension in the browser. To view all files in the current directory, leave the field blank.

Proxy Generation button When enabled, allows background proxy generation while soft-importing images. See [Importing and Soft-Importing in the Background](#) on page 227. This button is active when Soft-import is enabled and Proxies are turned on for your project.

Add To Queue box Select a method to import images in the background. See [Importing and Soft-Importing in the Background](#) on page 227.

Select:	To:
Add to Queue	Add the job to the queue.
Add to Queue & Execute	Add the job to the queue and execute it automatically. If there are any jobs in progress, this job (and any others already added with the Add to Queue & Execute option) is triggered upon the completion of its predecessor.

Destination Library box Select the destination library for the imported file. This applies to background import operations only. You should select a clip library that you are not currently using to ensure the library is not locked (read-only). Otherwise, the background operation is suspended until the library is unlocked.

Clip Media Group

Use these options to select how clip media is handled on import.

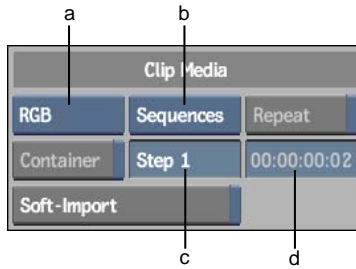

(a) Channels box (b) Load Method box (c) Step Factor field (d) Repeat field

Channels box Select the channels that you want to import. If the image has an alpha channel, you can load it with the image as is or inverted.

Select:	To load:
RGB	The image with no alpha channel.
RGBA	The image and its alpha channel. Two clips are created: the first clip contains the RGB image, and the second clip contains the alpha channel image. If the image does not contain an alpha channel, a single clip is created.
RGBA Inverted	The image and its alpha channel (inverted). Two clips are created: the first clip contains the RGB image, and the second clip contains the greyscale inverted alpha channel image.

Load Method box Select the method used to load images, whether a clip, sequences, or frames.

Select:	To load:
One Clip	All selected images into a single clip.
Sequences	All selected sequences and individual images into separate clips. Note that selected images in a sequence are loaded as one clip.
Frames	All selected images into separate, one-frame clips.

Repeat button Enable when you want to repeat a single frame for a given duration. Regardless of the load option, you can set the number of times the frame is repeated by entering a value in the Repeat field.

Matte Container button When enabled, creates a matte container to store the image and its matte. Matte Container is active when Channels is set to RGBA or RGBA Inverted.

Soft-Import button When enabled, images are soft-imported with foreground proxy generation.

Step Factor field Specifies the number of frames that you want to skip when importing a selection of images (which may or may not be part of a sequence). For example, a step factor of two imports every second frame. A step factor of one imports all frames.

Repeat field Enter a value for the number of times that you want to repeat a single frame for a given clip. This field is active when the Repeat button is enabled.

Clip Metadata Group

Use these options to select how clip metadata is handled on import.

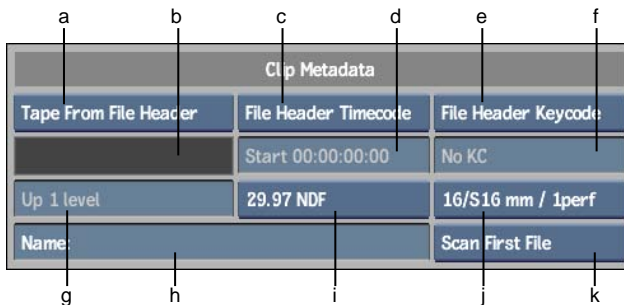

(a) Tape Name box (b) Tape Name field (c) Timecode box (d) Timecode field (e) Keycode box (f) Keycode field (g) Level field (h) Clip Name field (i) Framerate box (j) Film Gauge box (k) Import Keycode Strategy box

Tape Name box Select an option to determine how the tape name is set for the imported clips.

Select:	To:
Enter Tape	Activate the Tape Name field so that you can manually enter the tape name. When selecting multiple sequences for import, this tape name is used for all imported clips.
Tape From File Header	Read the tape name from the Input Device Name field (field 38) in the header of the file. The tape name detected for the currently se-

Select:	To:
	lected sequence is displayed in the Tape Name field. If multiple sequences are selected in the Files list, the tape name corresponding to the uppermost selected sequence will be displayed.
Tape From Directory	Infer the tape name from the detected directory structure. A Level field appears below the Tape Name field. Use this to configure the relative file path to the directory from which the tape name can be inferred.

Tape Name field Displays the tape name of the imported clip. If Tape Name is set to Enter Tape, then this field becomes active, allowing you to enter a tape name.

Timecode box Select an option to specify how the timecode information for the clip is set.

Select:	To:
Enter Timecode	Manually enter a timecode in the Timecode field.
File Header Timecode	Set the source timecode of the imported clip based on the timecode information in the image file header.
File Name Timecode	Use a numerical filename (for instance, <i>100000.dpx</i>) and translate it into timecode for the resulting clip (based on the selected frame code mode). This is useful when working with files from film scanners that do not have embedded timecode. Also, it is useful for reading the files generated by Lustre.

Timecode field Displays the timecode of the imported clip. If the Timecode box is set to Enter Timecode, then this field becomes active, allowing you to enter a starting timecode value for the imported clip.

Keycode box Select an option to determine how keycode data is applied to the imported clip.

Select:	To:
Enter Keycode	Manually enter a keycode in the Keycode field.
File Header Keycode	Load a clip based on the keycode information embedded in the image file header.
No Keycode	Not use keycode.

Keycode field Displays the keycode of the imported clip. If the Keycode box is set to Enter Keycode, then this field becomes active, allowing you to enter a starting keycode value for the imported clip.

Level field Select an option to set the relative file path to the directory from which the tape name can be inferred. Although it is available for all file types, the Level field is specifically designed to work with the directory structures that are output by film scanners. A typical file structure would look like: `./<tape>/<resolution>/clip.#####.dpx`. In this case, selecting *Up 2 Levels* in the Level field identifies the directory that corresponds to the tape name (`./<tape>`). The Level field is active when Tape Name is set to Tape From Directory.

Clip Name field Displays the name of the current clip. By clicking the field you activate it so that you can create or modify a clip name.

Framerate box Select the frame rate of the imported clip. If you are importing a DPX file, select File FCM to detect and use any existing framerate information in the DPX file to create the clip.

Film Gauge box Select a film gauge for the keycode.

Import Keycode Strategy box Select an import strategy for handling keycode. The Import Keycode Strategy box is active only when Load Method is set to Sequences and Keycode is set to DPX Keycode.

Select:	To:
Scan First File	Scan the keycode from only the header of the first file in a DPX sequence.
Scan First/Last Files	Scan the keycode from only the header of the first and last files in a DPX sequence.
Scan Every File	Scan the keycode from the header of every file in a DPX sequence.

Processing Group

Use the Resize options to change resolution, aspect ratio, bit depth, and field dominance. See [Resizing on Import, Export, or in a Clip Library](#) on page 665.

If Resize is disabled, you can force an aspect ratio for all the images selected for import, or use the Default Resolutions list to determine the aspect ratio for each individual image in the selection. See [Setting Default Image Resolution Characteristics on Import](#) on page 698.

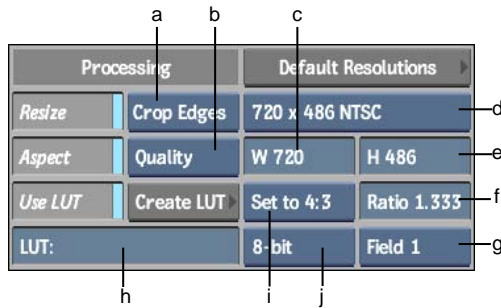

(a) Fit Method box (b) Resize Filter box (c) Frame Width field (d) Resolution Presets box (e) Frame Height field (f) LUT Name field (g) Aspect Ratio Presets box (h) Aspect Ratio field (i) Scan Mode box (j) Frame Depth box

Resize button When enabled, displays the Resize options that can affect one or more clips on import. If disabled, the Aspect Ratio Presets box and the Aspect Ratio field are still available. Resize options are not active when you soft-import media.

Aspect button When enabled, allows you to use non-square pixel formats. This button is active only when Fit Method is set to Crop Edges or Letterbox.

Fit Method box Select the fit method that is applied to the clips. Fit Method is active only when Resize is enabled.

Select:	To:
Pan	Fit the source image to the smaller destination frame by cropping and using the Pan Start X and Pan Start Y fields.
Centre/Crop	Fit the source image, centred, over the destination frame. If the source is larger than the destination, it is cropped. If the source is smaller than the destination, it is surrounded by a black border.
Crop Edges	Fit one edge of the source into the destination frame without stretching or squashing the frame. Excess parts of the source frame after resizing are cropped. If the source—after the one edge is resized—is wider than the destination, its overhanging left and right edges are cropped. If the source is taller than the destination, the upper and lower edges are cropped.
Fill	Fit the source, width and height, into the destination frame. If the source and destination frames do not have the same aspect ratio, the image can become distorted.

Select:	To:
Letterbox	Fit the source to the destination frame without squashing or stretching it, and without cropping the source. If the source is wider than the destination, black bars fill the top and bottom of the destination frame. If the source is narrower than the destination, black bars fill the right and left sides of the frame. In all cases, the entire source frame is contained within the destination frame.

Pan Start X field Enter the offset for horizontal position. Pan Start X is active only when Fit Method is set to Pan.

Pan Start Y field Enter the offset for vertical position. Pan Start Y is active only when Fit Method is set to Pan.

Resize Filter box Select the filter option to determine the quality of the interpolated resize result. Defining a filter method in the Resize menu will override the default setting specified in the Preferences menu. The Resize Filter box is active only if Fit Method is set to Crop Edges, Fill, or Letterbox.

Select:	For:
Bicubic	Best results when resizing a clip to a higher resolution. Processing time is increased compared to Medium, but decreased compared to Quality.
Quality	Best results when resizing a clip to a lower resolution. Processing time is increased compared to Medium.
Medium	Moderate results. Processing time is increased compared to Coarse.
Coarse	Poorest results in the least amount of processing time. A segment with a soft Resize can be played back in real time when using the Coarse resizing filter. Other options may require rendering.

Default Resolutions button Displays the Default Resolutions list. See [Default Resolutions List](#) on page 699.

Frame Width field Displays the frame width of the selected resolution preset. If Resolution Presets is set to Custom, then this field is active, allowing you to enter the frame width value that you want to use.

Resolution Presets box Select one of many standard resolutions, as well as a Custom option that you can use to specify non-standard resolutions.

Frame Height field Displays the frame height of the selected resolution preset. If Resolution Presets is set to Custom, then this field is active, allowing you to enter the frame height value that you want to use.

Create LUT button Create a custom LUT. See [Applying a LUT on Import or Export](#) on page 744. Create LUT is active only if Use LUT is enabled.

LUT Name field Displays the name of the currently used LUT file. When enabled, a browser appears containing the LUTs currently residing in the project `~/lut` directory. These include the samples provided with Flame, as well as any LUTs you may have saved or exported to this directory. LUT Name is active only when you enable the Use LUT button.

Use LUT button When enabled, activates Create LUT and LUT Name and uses a Lookup Table on import. Use LUT is active only if File Format is set to Cineon or Dpx, and Soft-Import is not enabled.

Aspect Ratio Presets box Select a standard frame aspect ratio. Select the Set to w:h option to set the clip to use square pixels. Select Custom to define a custom frame aspect ratio in the Aspect Ratio field.

Frame Depth box Select from one of five frame depth options: 8-bit, 10-bit, 12-bit, 12-bit u, or 16-bit fp. Frame Depth is active only when Resize is enabled.

Aspect Ratio field Displays the aspect ratio of the imported clip. When Aspect Ratio Presets is set to Custom, this field becomes active so that you can enter a custom frame aspect ratio.

Scan Mode box Select an option to determine the order in which the fields of interlaced material is scanned.

Select:	To:
Progressive	Scan a frame-based clip with no interlacing.
Field 1	Scan Field 1 first, followed by Field 2.
Field 2	Scan Field 2 first, followed by Field 1.

File Attributes Group

The File Attributes group displays the attributes that are available for a file, when its filename is selected in the file browser. These attributes may include any of the following: file type, pixel width, pixel height, colour model, timecode, keycode, aspect ratio, bit depth, and codec.

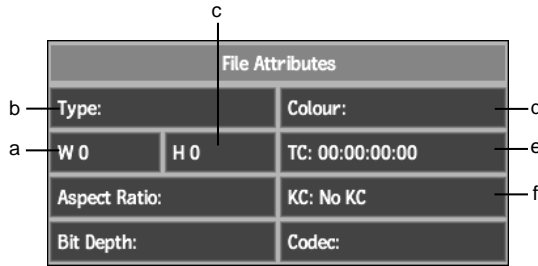

(a) Pixel Width (b) File Type (c) Pixel Height (d) Colour Model (e) Timecode (f) Keycode

Library Operations Options

Use these options to select what and how files are displayed for import.

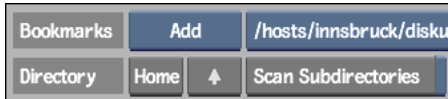
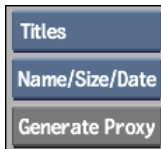

Generate Proxy button Click to generate thumbnail proxies in the Clip Library view.

Scan Subdirectories button Enable to display all of the image sequences that are detected in the nested subdirectories of a directory structure.

Importing and Soft-Importing Image Files

Import images created in other applications, such as 3ds Max, as well as images previously exported, using the Export Image menu. You can also import images from CD-ROM, floppy disk, or another platform (for example, a Macintosh or PC).

By default, clips are imported at source resolution. However, you can use the Resize option to modify imported file resolution. In this case, the default size becomes the project resolution, which you can then modify.

When you import clips containing multiple frames, the frames are saved as separate image files, each of which is assigned a sequentially-numbered filename. In the file browser, these image files appear under a single collapsible heading, which allows you to select all images in a sequence at once.

To import or soft-import an image file:

- 1 In the Library menu, click Import Image and select a destination reel.
- 2 In the File Format box, select the format of the media that you want to import, or select Auto to automatically detect the format of a file when you select it. See [File Operations Group](#) on page 201.



TIP If you select a file format, and the files that you want to import do not use the default extension, they do not appear in the browser. Enter the extension of the files in the Ext: field and they will appear in the browser. To view all files in the current directory, enter a blank extension.

- 3 Select the destination for the imported file using the Destination Library box.
- 4 Browse to the directory containing the media that you want to import. You can set a number of display and search options to help you find what you need. See [Navigating the Filesystem](#) on page 82.

NOTE By default, the file browser points to the images directory for the project.

- 5 Optional: Enable the Scan Subdirectories button to display all the subdirectories and their contents.
- 6 Select the images that you want to import.
- 7 Enable Soft-Import if you want to import a reference to the media, but you do not want to store the media on the local storage.

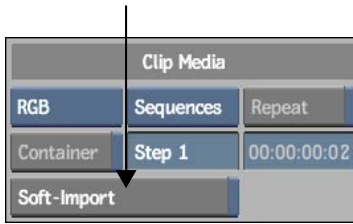

NOTE Certain options are disabled if you choose to soft-import the media.

8 Set any Clip Media properties.

You can choose to import an image with its alpha channel. See [Importing RGBA Files](#) on page 220. You can import an image as frames, sequences, or a clip. You can repeat frames or step through frames. See [Clip Media Group](#) on page 202.

9 Set the tape name for the imported clips and adjust any other Clip Metadata properties.

You can infer the tape name from a directory name, read the tape name from a file header, or enter the tape name manually. You can also read timecode and keycode information from the clip. See [Clip Metadata Group](#) on page 204.

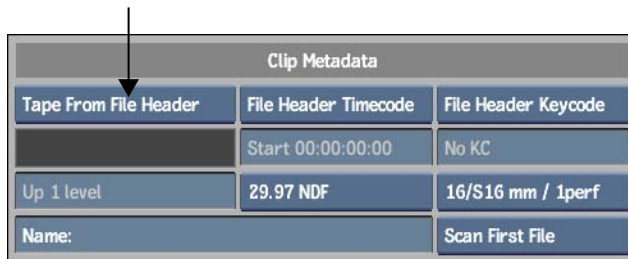

10 Optional: Use the Resize options to modify the imported file resolution. See [Setting Default Image Resolution Characteristics on Import](#) on page 698.



- Specify a LUT to remap specific pixel values when you import. See [Colour Management with LUTs](#) on page 729.



- Click Load.

If the width of the image that you are importing or soft-importing is a not multiple of 4 for 8-bit images, or 2 for 10-, 12-, or 16-bit images, you will be prompted to confirm that you want to pad its width to the next highest multiple. Click Confirm to proceed. If the image is part of a sequence, click Confirm All to automatically apply the padding to all images in the sequence.

The images are imported to the desktop.

NOTE Soft-imported media is labelled with the file type in the lower-right corner. See [Recognizing Soft-Imported Clips](#) on page 200.

Importing DPX File Sequences for Data Conform

The following workflow is designed specifically to accommodate importing or soft-importing DPX sequences generated from a film scanner. This allows you to import DPX sequences originating from different film reels in a single step. You can efficiently batch-capture file-based media in preparation for data conform from an EDL. The imported clips all have the correct source

keycode, timecode, and tape name, making it easy to load your EDL and assemble the timeline for conforming and finishing.

To import DPX file sequences for data conform:

- 1 From the Library menu, click Import Image and select a destination reel.
- 2 In the Import Image menu, browse to the top-level directory that contains all the subdirectories and image sequences that you want to display.
Typically, all DPX sequences generated by a film scanner reside in a top-level *<project>* directory, sorted into subdirectories corresponding to tape name, resolution, and sometimes clip name, as follows:
./<project>/<tape>/<resolution>/.#####.dpx*
- 3 From the Format box, select the DPX image type.
You can select any single, supported image type. The default type for image files is DPX because this is a DI standard that embeds source metadata in the file header.



- 4 Optional: Enable Filter and enter the appropriate criteria to focus your search.
The criteria is checked against the entire path. For example, if you enter **2048**, the filter will list only those sequences that reside under a directory path containing the string "2048". In this case, only 2K sequences are displayed while everything else, such as 1K proxies or thumbnails, is filtered out.
- 5 Enable Scan Subdirectories.

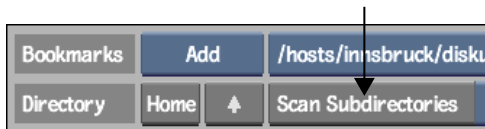

The directory scan begins. This may take some time to complete, depending on the size and quantity of subdirectories and files.

When the scan is complete, the Files list displays all detected files with the directory path relative to the top-level directory. The list is sorted alphanumerically by path and filename.

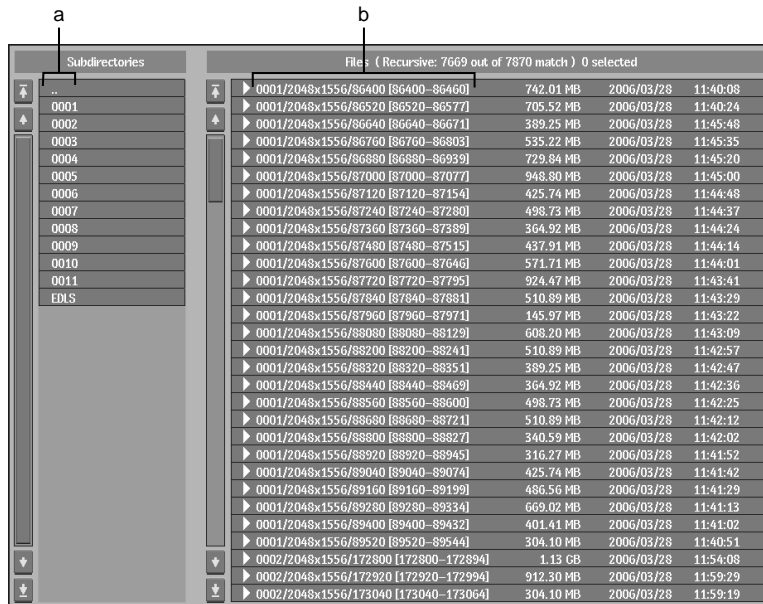

(a) Subdirectories in the scanned directory (b) All nested subdirectories with full path

TIP For long filenames that may be clipped in the browser, hold down the **Alt** key while hovering over the filename. This displays the full filename in a floating window.

The results of the scan remain until you browse upwards to another directory, in which case the Scan Subdirectories option gets disabled.

- 6 Select the images that you want to import.
- 7 From the File Timecode box, select File Header Timecode.
This will set the source timecode of the imported clip based on the timecode information in the DPX image file header.
- 8 From the Keycode box, select File Header Keycode.

This option allows DPX files that contain keycode data to be imported with their keycode data intact.

NOTE For 35mm / 3 perf and 35mm / 4 perf keycode, both perforation and frame offset modes can be read from the DPX files. For all other film gauges, only frame offset mode can be read.

- 9 From the Framerate box, select File FCM.

This option allows you to detect and use any existing framerate information in the DPX file to create the clip.

- 10 From the Film Gauge box, select the gauge corresponding to the source film from which the images originated.

This value is necessary because keycode values are assigned to each frame of the sequence differently, depending on the film gauge.

- 11 Set the tape name for the imported clips.

You can either infer the tape name from a directory name or read the tape name from a DPX file header. Do one of the following:

- To infer the tape name from a directory name, from the Tape Name option box, select Tape From Directory, then use the Level field to configure the relative file path to the directory from which the tape name can be inferred.

This is designed to work with the directory structures that are output by film scanners. For example: `./<tape>/<resolution>/clip.#####.dpx`. In this case, selecting *Up 2 Levels* in the Level field identifies the directory that corresponds to the tape name.

- To read the tape name from the DPX file header, from the Tape Name box, select Tape From File Header.

The tape name is read from the Input Device Name field (field 38) in the header of the DPX file and is displayed in the Tape Name field. There is currently no industry standard for embedding the tape name in the DPX header. Some film scanners, such as the ARRISCAN, write the tape name associated with a film frame into field 38 of the DPX header. Other scanners, for example, Imagica or Filmlight, allow field 38 to be user-definable, although the default value is not the tape name.

NOTE Before using the DPX Tape name feature, consult with your film scanner operator to ensure compatibility.

- 12 Specify a LUT to remap specific pixel values when you import the DPX images. See [Colour Management with LUTs](#) on page 729.



- 13 Optional: Perform any resizing operations.
When you disable the Resize button during import operations, the aspect ratio of the clip reverts to default. See [Processing Group](#) on page 206.
- 14 Enable Soft-Import if you want to import a reference to the media, but you do not want to store the media on the local storage.
- 15 Optional: Select a queuing option from the Add To Queue box.



- If you soft-import clips you can generate proxies in the background. This gives you the ability to assemble the timeline while proxy generation is taking place. See [Importing and Soft-Importing in the Background](#) on page 227.
- 16 Click Load.
After you have imported or soft-imported all the sequences, you can import the corresponding EDLs to assemble a clip with unlinked media, then relink the clip to the DPX files in the reel.

Importing OpenEXR Files

OpenEXR files have the ability to store high dynamic range images in 16-bit or 32-bit floating-point formats. Because of this high dynamic range, these images need to be handled in a specific way. You can import an OpenEXR image file and view it in Flame the same as any other type of image file. But, in order to perform any image processing or compositing on the OpenEXR image file, you must apply a conversion to store it in a 12-bit, 10-bit, or 8-bit linear format on Autodesk storage.

You can convert OpenEXR image files using the LUT Editor to process which areas of the image that you want to highlight or preserve. See [Colour Management with LUTs](#) on page 729.

Alternatively, you can select the Resize option and set the Bit Depth to 8-, 10-, or 12-bit to affect a linear resizing on the OpenEXR image file. Note that with this method you have no control over which areas get highlighted or preserved.

To import an OpenEXR image file:

- 1 From the Library menu, click Import Image and select a destination reel.
- 2 From the Format box, select the OpenEXR image type.

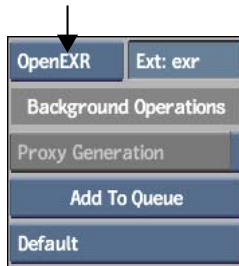

- 3 Browse to the directory containing the media that you want to import. You can set a number of display and search options to help you find what you need. See [Navigating the Filesystem](#) on page 82.

NOTE By default, the file browser points to the images directory for the project.

- 4 Optional: Enable the Scan Subdirectories button to display all the subdirectories and their contents.
- 5 Select the image that you want to import.

- In the File attributes area, ensure that the Bit Depth used in the OpenEXR image file is displayed.

File Attributes		
Type: OpenEXR		Colour: RGBA
W 720	H 486	TC: 00:00:00:00
Aspect Ratio: N/A		KC: No KC
Bit Depth: 32-bit fp		

- Optional: Specify a previously-created LUT.

Processing		Default Resolutions	
Resize	Crop Edges	720 x 486 NTSC	
Aspect	Quality	W 720	H 486
Use LUT	Create LUT	Set to 4:3	Ratio 1.333
LUT:		8-bit	Field 1

- Optional: Perform any resizing operations.

Adjusting the Bit Depth to anything other than 16-bit fp will cause a linear resizing to occur on the OpenEXR file, negating any of its dynamic qualities.

- Enable Soft-Import if you want to import a reference to the media, but you do not want to store the media on the local storage.
- Optional: Select a queuing option from the Add To Queue box.

Dpx	Ext: dpx
Background Operations	
Proxy Generation	
Add To Queue	
ExportIO	

If you soft-import clips you can generate proxies in the background. This gives you the ability to assemble the timeline while proxy generation is

taking place. See [Importing and Soft-Importing in the Background](#) on page 227.

11 Click Load.

After you have imported the OpenEXR image, you can view it in its native resolution and bit depth.

12 To perform any image processing or compositing, you will need to convert it using the Lut Editor. See [Colour Management with LUTs](#) on page 729.

Importing RGBA Files

When you import an RGBA file into Flame, you can import the RGB image and the alpha channel as separate clips. The alpha channel can be imported as is or inverted. You can also import the RGB image and alpha channel and place them in a matte container.

To import or soft-import an RGBA file:

- 1 From the Library menu, click Import Image and select a destination reel.
- 2 In the Import Image menu, browse to the directory containing the media with the alpha channel and select the files.
- 3 From the Channels box, select one of the following:
 - RGBA to import the image and the alpha as is, as separate clips.
 - RGBA Inverted to import the image and the alpha inverted, as separate clips.

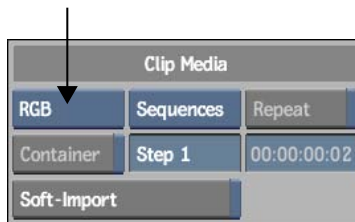

- 4 Enable Soft-Import if you want to import a reference to the media, but you do not want to store the media on the local storage.
- 5 Optional: Select a queuing option from the Add To Queue box.

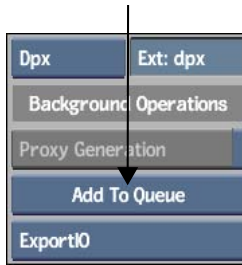

If you soft-import clips you can generate proxies in the background. This gives you the ability to assemble the timeline while proxy generation is taking place. See [Importing and Soft-Importing in the Background](#) on page 227.

6 Click Load.

The RGB image and the alpha channel are loaded separately to the desktop.

To import or soft-import an RGBA file into a matte container:

- 1 From the Library menu, click Import Image and select a destination reel.
- 2 Browse to the directory containing the media with the alpha channel and select the files.
- 3 From the Channels box, select RGBA or RGBA Inverted.



- 4 Enable Container to create a matte container.
- 5 Enable Soft-Import if you want to import a reference to the media, but you do not want to store the media on the local storage.
- 6 Optional: Select a queuing option from the Add To Queue box.



If you soft-import clips you can generate proxies in the background. This gives you the ability to assemble the timeline while proxy generation is taking place. See [Importing and Soft-Importing in the Background](#) on page 227.

- 7 Click Load.

The RGB image and the alpha channel are loaded into the clip library and are merged into a single clip inside a matte container.

- 8 In the clip library, select the clip and click Load.

The file is loaded to the clip library and the words Matte Container are appended to the end of the filename.

Importing Adobe Photoshop Files

You can import Adobe Photoshop format files into your project without having to convert them. Photoshop files are usually created with multiple layers, each with its own image, matte, or blending effect. You can use the imported file's layers and effects, or you can import the file as a flat image so it appears as a single layer or frame.

You can also import Photoshop files from Action. See [Importing Photoshop Files into Action](#) on page 2130.

Photoshop files have the following characteristics when imported:

- Converted to 8 bits
- Progressively scanned
- Do not use a LUT
- Cannot be resized
- Cannot be soft-imported

To import a PSD file:

- 1 From the Library menu, click Import Image and select a destination reel.
- 2 From the File Format box, select Photoshop.



- 3 Select a Photoshop file in the browser.
- 4 Select an import option from the Photoshop Import Mode box.

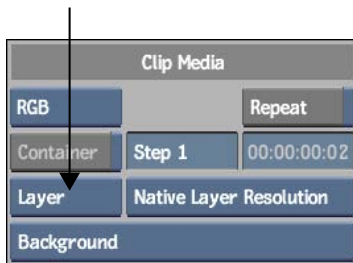

Select:	To:
Flat	Import all the layers in the Photoshop file as a single-frame clip.
All	Import all the layers in the Photoshop file as single frames in a front+matte sequence.
Layer	Import a single layer from a Photoshop file. You can choose the layer from the Select Layer box. The layer names are identical to those defined in the Photoshop file. If you selected RGBA in the Channels box, the file is imported as two clips (front and matte). If you selected RGB, the file is imported as a single clip (front).

- 5 If you selected Layer, then select the layer in the Photoshop file that you want to import from the Source Layer box.

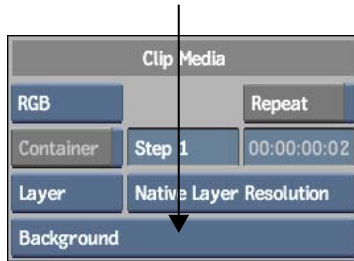

- 6 If you selected All or Layer, then you must also select a resolution for the imported Photoshop file from the Photoshop Import Resolution box.

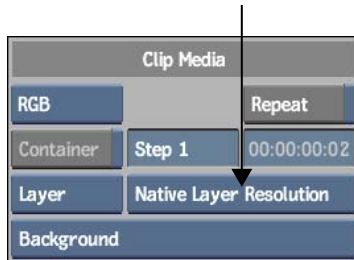

Select:	To:
Native Layer Resolution	Import the layers at their original resolution.
Background Resolution	Import the layers at the project's background resolution. Layers will be padded (black) and offset.

- 7 Click Load.

The Photoshop image and its selected layers are imported as frames on the desktop at the defined resolution.

Importing and Soft-Importing Video Files

Use the Import Image menu to import or soft-import one or more QuickTime movies or MXF media files to the current clip library. Both video and audio tracks are supported.

Audio files that are not 48 KHz are automatically resampled to 48 KHz on import. For video files that contain an alpha channel, you can maintain the alpha channel in the imported clip for use in compositing.

Before importing any MXF P2 content, ensure that the P2 recording devices that are used are set to record clip metadata in Type 2. This allows important metadata, such as the User Clip Name, to be assigned properly in the MXF file.

Note that you cannot import or soft-import MXF P2 content that contain 2:3 or 2:3:3:2 pulldown, or variable framerates (such as from Varicam cameras).

A QuickTime or MXF video file can be encoded with any of a number of different codecs. During import, the codec flag and other detected metadata for a supported movie appears in the Movie Attributes area. Note that there are some codecs that will display, but are not supported. Otherwise, a message appears indicating that the movie cannot be imported.

Movie Attributes		Video	Audio
Type: QuickTime		YUV	1 Channels
W 720	H 480	1.500000	22050
TC: 00:00:00:00		8-bit	16
Duration: 276		yuv2	twos

NOTE To import files created using unsupported video file formats or codecs, you can use Cleaner XL to encode the files into a supported format. For example, use Cleaner XL to import video as a sequence of compatible still images. See the guide, *Using Cleaner XL with Autodesk Visual Effects and Finishing Applications*.

To import or soft-import a QuickTime movie or MXF media file:

- 1 From the Library menu, click Import Image and select a destination reel.
- 2 From the File Format box, select the format of the clip that you want to import.

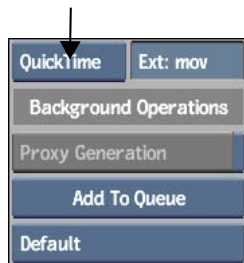

- 3 Browse to the directory containing the video files that you want to import, and then select the files.

TIP If the files that you want to import do not use the default extension, they do not appear in the browser. Enter the extension of the files in the Ext: field and they will appear in the browser. To view all files in the current directory, enter a blank extension.

- 4 Optional: Enable Scan Subdirectories to display all the subdirectories and their contents.
- 5 Enable Soft-Import if you want to import a reference to the media, but you do not want to store the media on the local storage.

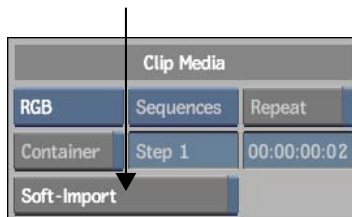

NOTE Certain options are disabled if you choose to soft-import the media.

- 6 If you are importing MXF files, select whether you want to import only a single file or the entire P2 content.

P2 content includes all of the associated audio files, which are embedded in the timeline. To import audio only select Essence from the MXF Options box. Use the P2 option only when importing the entire structure.

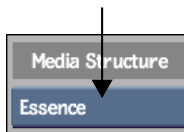

- 7 Adjust any other properties in the Clip Media, Clip Metadata, or Processing groups. See [About the Import Image Menu Options](#) on page 201.

NOTE A clip that is imported using an unsupported frame rate is converted to the frame rate specified for the current project. This causes the clip to appear out of sync with its audio. A comment specifying the original frame rate is added to the clip notes, providing the ratio needed if you choose to re-time the video.

- 8 In the Movie attributes area, ensure that the codecs used in the video file are displayed.

During import, the codec flags for video and audio, and other detected metadata for a supported movie appears in the Movie Attributes area.

Movie Attributes		Video	Audio
Type: QuickTime		YUV	1 Channels
W 720	H 480	1.500000	22050
TC: 00:00:00:00		8-bit	16
Duration: 276		yuv2	twos

- 9 Click Load.

The video files are imported to the desktop and to the specified library reel.

Importing and Soft-Importing in the Background

You can import one or more image or video files in the background while you perform other tasks. When soft-importing one or more image or video files, you can generate the proxies in the background.

To perform any of these tasks on several files at once, you can select them and then process them as a batch. You can assign different clip options to each file that you add to the queue. You can also import and export files simultaneously. Background tasks continue to completion even after you exit the application.

When importing files as a background process, you import them to a Destination clip library rather than to the desktop. The Destination library needs to be unlocked (you must not be currently browsing in it) for the operation to complete. If this library is locked, the new clip cannot be written to it. In this case, it gets placed temporarily in a generated library until the Destination library becomes available.

To import in the background:

- 1 From the Library menu, click Import Image and select a destination reel.
- 2 Select an option from the Add to Queue box.

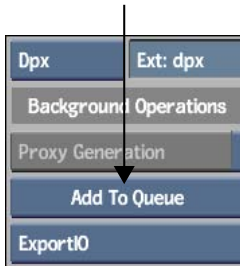

This action will add the job to the Background Import/Export Queue.

Select:	To:
Add to Queue	Add the job to the queue.
Add to Queue & Execute	Add the job to the queue and execute it automatically. If there are any jobs in progress, this job (and any others already added to the queue with the Add to Queue & Execute option) will be triggered upon the completion of its predecessor.

The progress of the import or export job is indicated in the queue.

Status:	Indicates:
Pending	Job has been added to the queue but not executed.
Queued	Job has been initialised.
Running	Job is being performed.
Done	Job has been executed.

- 3 Continue building the Background Import/Export Queue:
 - If you are adding import jobs to the queue, you can continue using the file browser to locate other files that you want to import.
 - If you are adding export jobs to the queue, click Exit Export Image to return to the desktop, select the next clip to be exported, and repeat this procedure.

- 4 To manage the Background Import/Export Queue, see [Managing the Background Import/Export Queue](#) on page 300.

To generate proxies in the background:

- 1 From the Library menu, click Import Image and select a destination reel.
- 2 Enable Soft-Import.

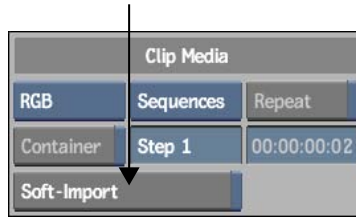

The Proxy Generation button becomes active.

- 3 Click Proxy Generation.

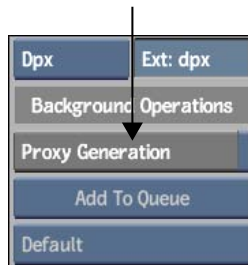

The soft-import process occurs in the foreground, while the proxy generation process occurs in the background.

- 4 To manage the Background Import/Export Queue, see [Managing the Background Import/Export Queue](#) on page 300.

Importing and Soft-Importing Audio Files

You can import or soft-import one or more audio files to the current clip library using the Import Audio menu. If your system has a CD-ROM drive, you can import music from a CD as MP3, WAV, or AIFF files.

The native audio sample rate for all Flame projects is 48 kHz. Audio at a different sample rate that you import is automatically resampled to 48 kHz. Audio files that are soft-imported must be 48kHz.

To import an audio file:

- 1 In the Library menu, click Import Audio. Alternatively, from the AudioDesk, click Import Audio File.

The Import Audio menu appears.

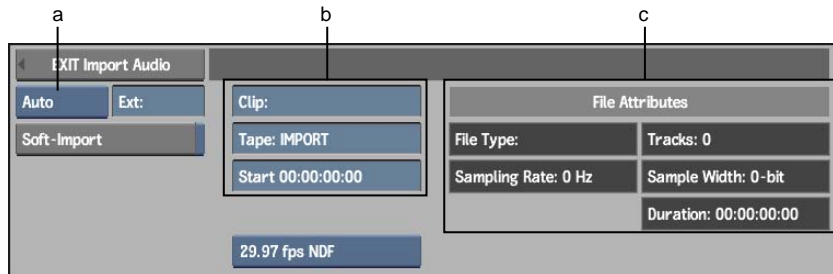

(a) File Format box (b) File Attributes area (c) Clip Properties area

- 2 From the Audio File Format box, select either the file extension of the file that you want to import, or Auto to automatically detect the file type. See the description of the File Format box in [About the Import Image Menu Options](#) on page 201 for information about the Auto option.

If you selected a file extension, the file browser displays audio files in the current directory with that file extension.

NOTE To browse the contents of a CD-ROM, type /CDROM in the Directory Name field.

- 3 Browse to the directory containing the audio files that you want to import, and then select the files.
If you select a single file, the audio file information appears below the browser.
- 4 If you are importing Broadcast Wave audio files, from the Wave TC box, select Broadcast Wave TC.

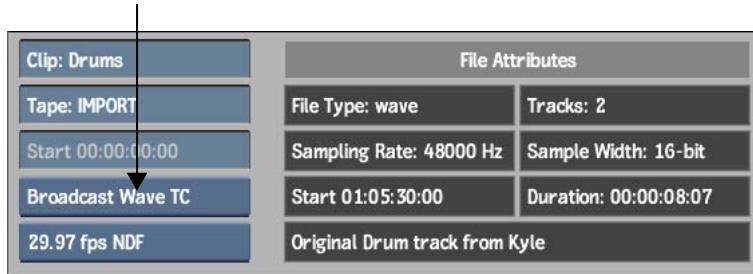

- 5 Enable Soft-Import if you want to import a reference to the media, but do not want to store the media on the Autodesk storage.

Changes to the media will update automatically. You do not have to re-soft-import the media.

- 6 Click Load.

When the import is finished, audio clips appear in the Player as black proxies. Soft-imported audio clips are labelled with the file type in the lower-right corner.



NOTE If the Waveforms Enabled and Build on Input/Import options are enabled in the Audio Preferences menu, waveforms are built during the import.

To import music from a CD:

- 1 Insert a CD into your computer's CD-ROM drive.
- 2 In the Library menu, click Import Audio.
- 3 To detect the CD-ROM drive, enable CD ROM in the Import Audio File menu.



- 4 From the File Format box, select AIFF, WAV, or MP3.
- 5 Browse to the CD-ROM drive, and select the tracks that you want to load.
The songs on the CD may be listed numerically, such as *track1.aiff*, *track2.aiff*, etc.
- 6 Click Load.
The selected audio tracks are imported.

Deleting Media Files From the Filesystem Via Import Image

You can use the file browser in the Import Image menu to remove image files, including soft-imported image files, from the filesystem.

To remove media files:

- 1 From the Library menu, click Import Image and select a destination reel.
- 2 Display the directory containing the files that you want to remove.
- 3 Select the files.
- 4 Click Remove, then click Confirm.

NOTE If you remove soft-imported files, the source media is not deleted; only the reference to the clip is deleted.

Exporting Media Files

10

Topics in this chapter:

- [About Exporting Media Files](#) on page 233
- [Supported File Formats](#) on page 234
- [About the Export Image Menu Options](#) on page 237
- [Exporting Image Files](#) on page 245
- [Exporting RGBA Image Files](#) on page 248
- [Exporting DPX Files](#) on page 249
- [Exporting Video Files](#) on page 251
- [Working with Codec Profiles](#) on page 254
- [Exporting Image Files in the Background](#) on page 258
- [Exporting Audio Files](#) on page 259
- [Exporting Media to Cleaner XL for Encoding](#) on page 264
- [Deleting Media Files From the Filesystem Via Export Image](#) on page 268

About Exporting Media Files

At various times during the post-production process, you may need to export media files from Flame. You can export still images (for example, TARGA, JPEG, TIFF), QuickTime video files, and audio files (for example, AIFF, MP3, WAV) from your Flame project.

You can export files one at a time, or add them to a queue for background export. There may also be occasions where you need to create still images from your clips, for example, for promotional material. Or, you may need to create video files for inclusion on a Web site. You can export graphic and audio files either in the foreground or background. You can export video files only in the background.

Supported File Formats

You can export image files using a number of industry-standard file formats. Each file format is exported using a default file extension.

Supported Image File Formats

Flame supports export of the following still image file formats.

File Format	Default File Extension	Bit Depth
Alias	als	8 bits
Cineon	cin	10 bits
DPX	dpx	8, 10, or 12 bits
Jpeg	jpg	8 bits
OpenEXR	exr	8, 10, 12u, 12, or 16 fp bits
Photoshop	psd	n/a
Pict (Macintosh)	pict	8 bits
Pixar	picio	8 bits
SGI	sgi	8 or 16 bits
Softimage	pic	8 bits
TARGA	tga	8 bits
Tdi/Maya	iff	8 or 16 bits

File Format	Default File Extension	Bit Depth
Tiff	tif	8 or 16 bits
Wavefront	rla	8 or 16 bits
QuickTime	mov	8 bits

Supported Audio File Formats

Flame supports export of the following audio file formats.

File Format	Default File Extension	Bit Depth (for Export)
AIFF-C	aifc	16, 24, or 32 (float)
AIFF	aiff	16 or 24
Nextsnd	au	16, 24, or 32 (float)
MP3	mp3	na
Broadcast Wave	wav	16, 24, or 32 (float)
Berkeley/IRCAM/CARL Sound (BISCF)	bsf	16
Audio Visual Research	avr	16

Supported QuickTime File Codecs

Flame supports export of QuickTime files encoded with any of the following codecs.

Broadcast CODEC	CODEC Flag	Comment
10-bit Packed YUV 4:4:4	v410	

Broadcast CODEC	CODEC Flag	Comment
10-bit Packed YUV 4:2:2	v210	Blackmagic or AJA-Kona 10-bit compatible
8-bit Planar YUV 4:4:4	v308	
8-bit Packed YUV 4:2:2	yuv2	Blackmagic or AJA-Kona 8-bit compatible
8-bit Packed YUV 4:2:2	2vuy	Blackmagic or AJA-Kona 8-bit compatible
DV 25 NTSC	dvc	
DV 25 PAL	dvcv, dvpp	
DVCPRO 50 NTSC	dv5n	Panasonic standard
DVCPRO 50 PAL	dv5p	Panasonic standard

File CODEC	CODEC Flag	Comment
MPEG-4	mp4v	
MSMpeg 4v3	DIV3	DivX 3 MPEG-4 compatible
PhotoJPEG	rtjpeg	RT PhotoJPEG compatible
MJPEG	MJPG	JPEG compatible
PNG	png	Portable Network Graphic sequence (no alpha support)
PNGA	pngalpha	Portable Network Graphic sequence (with alpha support)
RGB Uncompressed	raw	No alpha support
RGBA Uncompressed	rawalpha	With alpha support

Audio CODEC	CODEC Flag	Comment
IMA 4:1	ima4	
Twos	twos	16-bit PCM (Big Endian)
Ulaw	ulaw	
Sowt	sowt	16-bit PCM (Little Endian)
A-law 2:1	alaw	
24-bit PCM	in24	
Linear PCM (QT 7)	lpcm	
32-bit float	fl32	
MPEG-2 Layer 2 Audio	mp2	

About the Export Image Menu Options

The Export Image menu contains a large variety of options that can be used when exporting image or video files. The menu is divided into seven functional groups:

- File Operations
- Export Options
- Quality
- Resizing
- Transfer Characteristics
- Proxies
- Export Video Options

For descriptions of additional options in the Export Image menu, see [Navigating the Filesystem](#) on page 82.

File Operations Group

Use the options in the File Operations group to select the File Format of the exported image and to set background output operations.

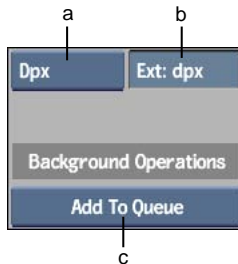

(a) File Format box (b) File Extension field (c) Background Export box

File Format box Select the image format that you want to export.

File Extension field Displays the default extension for the file type selected in the File Format box. By clicking it you activate the field, allowing you to enter a different extension for the exported file.

Background Export box Select a method to export images in the background. See [Exporting Image Files in the Background](#) on page 258.

Select:	To:
Add to Queue	Add the job to the queue.
Add to Queue & Execute	Add the job to the queue and execute it automatically. If there are any jobs in progress, this job (and any others already added with the Add to Queue & Execute option) will be triggered upon the completion of its predecessor.

Export Options Group

When you export a clip, you have a number of options for naming and numbering the sequence of image files that are generated. Image files can be numbered sequentially so that the order of frames in the clip can be maintained if you later import the clip. You can also specify the start number in a sequence of images.

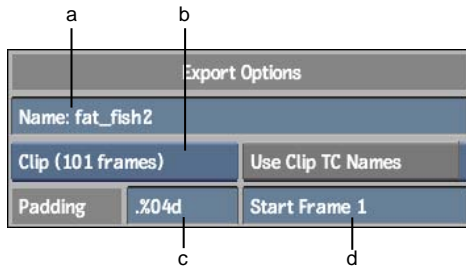

(a) Clip Name field (b) Frame/Clip box (c) Padding Format field (d) Start Frame Number field

Clip Name field Displays the name of the current clip. By clicking the field you activate it so that you can modify or enter a clip name.

Frame/Clip box Select whether you are exporting a single frame or a clip.

Select:	To:
Single Frame	Export a clip composed of one frame. If the clip has more than one frame, only the first frame is exported.
Clip	Export a clip composed of several frames. The number of frames in the clip is displayed.

Use Clip TC Names button Enable to set the start number of the exported sequence of numbered image filenames based on the timecode read from the clip file.

Padding Format field Edit the padding format string that adds leading zeros before the number in the exported filename. This ensures that the images are listed and stored in the correct order. The default padding format scheme is `%04d`, where the “0” indicates that leading zeros will be appended to the filename for each frame, when there are fewer than four digits in the sequence number, and the “4d” indicates that four digits will be maintained. You could use 3, 5, or any other number instead. However, four digits are sufficient for most clips, as they provides correct numbering in clips up to 9999 frames long.

Start Frame Number field Enter the start number to be used in the exported sequence of numbered image files. This field is not active when Use Clip TC Names is enabled.

Quality Group

Depending on the file format you are exporting, you may have the option of applying image compression to the exported frames to create smaller files. When compressing files, keep in mind that as you increase the compression, you decrease the quality of the image.

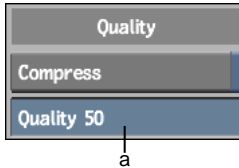

(a) JPEG Quality field

Compress button Enable to apply compression to the exported file, resulting in smaller file size (and lower image quality). This button is active when File Format is set to OpenEXR, SGI, or Tiff. The compression type used for OpenEXR files is RLE (lossless).

JPEG Quality field Specifies the degree of quality versus compression. A value of 0 gives the lowest quality (and highest compression), while a value of 100 gives the best quality (but applies no compression). This button is active only when File Format is set to JPEG.

Resizing Group

You can change the size, aspect ratio, bit depth, image quality, and border colour when exporting images.

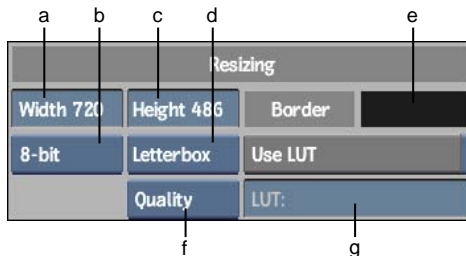

(a) Frame Width field (b) Bit Depth box (c) Frame Height field (d) Fit Method box (e) Border Colour pot (f) Resize Filter box (g) LUT Name field

Frame Width field Displays the frame width of the selected clip. By clicking it you activate the field, allowing you to enter the frame width value that you want to use on export.

Frame Height field Displays the frame height of the selected clip. By clicking it you activate the field, allowing you to enter the frame height value that you want to use on export.

Border Colour pot Displays the colour that is used for the border. When you click the colour field, the colour picker appears. From the colour picker you can select the colour to be used for the border when the aspect of the image is resized on export.

Bit Depth box Select a bit depth to be used on export. Some file formats support multiple bit depths. Bit Depth is active only when Resize is enabled.

Fit Method box Select a fit method option to be applied to the exported clip.

Select:	To:
Centre/Crop	Fit the source image, centred, over the destination frame. If the source is larger than the destination, it is cropped. If the source is smaller than the destination, it is surrounded by a black border.
Crop Edges	Fit one edge of the source into the destination frame without stretching or squashing the frame. Excess parts of the source frame after resizing are cropped. If the source—after the one edge is resized—is wider than the destination, its overhanging left and right edges are cropped. If the source is taller than the destination, the upper and lower edges are cropped.
Fill	Fit the source, width, and height, into the destination frame. If the source and destination frames do not have the same aspect ratio, the image can become distorted.
Letterbox	Fit the source to the destination frame without squashing or stretching it, and without cropping the source. If the source is wider than the destination, black bars fill the top and bottom of the destination frame. If the source is narrower than the destination, black bars fill the right and left sides of the frame. In all cases, the entire source frame is contained within the destination frame.
Pan	Apply X and Y offsets (with 0,0 pinning the lower-left corners of each frame) to place the source over the destination frame. If the source is larger than the destination, or lies off the edges of the destination frame

Select:	To:
----------------	------------

due to offsets, it is cropped. Empty space in the frame is filled with black.

Resize Filter box Select the filter option to determine the quality of the interpolated resize result. The Resize Filter box is active only if Fit Method is set to Crop Edges, Fill, or Letterbox.

Select:	For:
----------------	-------------

Bicubic	Best results when resizing a clip to a higher resolution. Processing time is increased compared to Medium, but decreased compared to Quality.
Quality	Best results when resizing a clip to a lower resolution. Processing time is increased compared to Medium.
Medium	Moderate results. Processing time is increased compared to Coarse.
Coarse	Poorest results in the least amount of processing time. A segment with a soft Resize can be played back in real time when using the Coarse resizing filter. Other options may require rendering.

Use LUT button When enabled, activates LUT Name and uses a Lookup Table on export.

LUT Name field Displays the name of the currently used LUT file. When clicked, a browser appears containing the LUTs currently residing in the project `~/lut` directory. These include the samples provided with Flame, as well as any LUTs you may have saved or exported to this directory. LUT Name is active only when you enable the Use LUT button.

DPX Transfer Characteristics Group

When exporting DPX files, you can choose a DPX Transfer Characteristic. A DPX Transfer Characteristic is information that is stored in the DPX image file header. It identifies the attributes associated with a particular film or video format, such as resolution, frame rate, and colour space.

Setting a Transfer Characteristic in no way changes the image information stored in the DPX file. The Transfer Characteristic simply indicates the attributes of the DPX file to another device or application. Some devices or applications may take advantage of this information to improve workflow. For example, selecting Logarithmic can allow a film recorder to adjust its parameters to print film-originated DPX files with the correct densities.

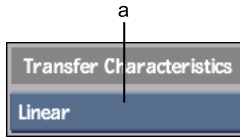

(a) Transfer Characteristics box

Transfer Characteristics box Select a DPX Transfer Characteristic to identify the attributes associated with a particular film or video format, such as resolution, frame rate, and colour space. Transfer Characteristics is only active when File Format is set to DPX.

Select:	For:
Z depth homogeneous Z depth linear PAL NTSC CCIR 601 (525) CCIR 601 (625) CCIR 709-1 SMPTE 240M	Images that you want to identify as one of these types. Although the SMPTE 268M standard defines these DPX Transfer Characteristics, it does not provide usage specifications for them. As a result, these Transfer Characteristics are not generally used in the industry.
Unspecified	Images where the format is not specified.
Logarithmic	Negative film scanners recording status M densities.
Linear	Video images which have built-in gamma correction. This refers to images having a true linear quantization scheme (such as CG-originated material).
Printing Density	Negative film scans which use the SMPTE Printing Density settings. SMPTE Printing Densities use status M density measurements with a higher gain in the red component.

Proxies Group

You can generate proxies when you export a clip. You can see the proxies when viewing the image files in the file browser using Proxies mode. If a proxy has not been generated for an image file, the proxy appears grey.

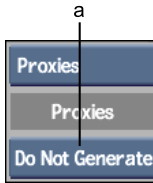

(a) Proxy Generation box

Proxy Generation box Select an option to determine how to generate proxies when you export a clip.

Select:	To:
Do not Generate	Not generate a proxy for the exported clip.
One Per Clip	Generate one proxy for the exported clip.
One Per Frame	Generate a proxy for every frame of the exported clip.

Export Video Options

Export Video options are active only when you are exporting a QuickTime video. You can export video files of almost any size. You can apply different compression rates to create files with a suitable trade-off between image quality and file size.

The Export Image menu changes slightly to accommodate the Export Video options.

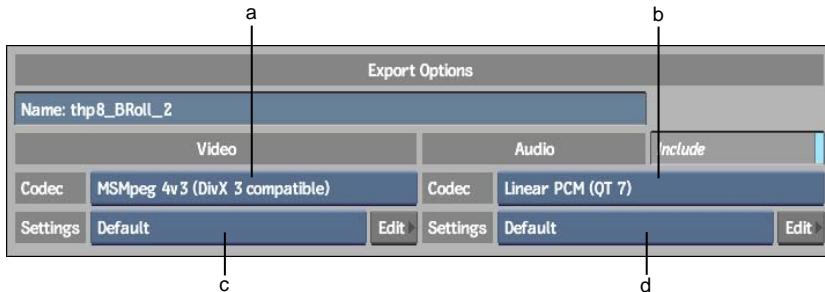

(a) Video Codec box (b) Audio Codec box (c) Video Codec Presets box (d) Audio Codec Presets box

Video Codec box Select a video compression codec when exporting QuickTime files.

Audio Codec box Select an audio compression codec when exporting QuickTime files.

Video Codec Presets box Select a previously defined video compression codec profile when exporting QuickTime files.

Audio Codec Presets box Select a previously defined audio compression codec profile when exporting QuickTime files.

Exporting Image Files

You can export a clip or a single frame from the desktop reels or a clip library to the filesystem or a storage device. After you have exported a clip, you can use it on other platforms (for example, Macintosh or Windows®).

When you export a clip to the filesystem, each frame in the clip is saved as a separate image file. The images are assigned sequential numbers that are appended to the filename.

The procedures for exporting image files either from the desktop or from the clip library are presented here.

To export an image file from the desktop:

- 1 In the Library menu, click Export Image.
The cursor changes to a red selection arrow and the Front/Matte and Clip/Range boxes appear.
- 2 Select Front to export RGB images.
If you plan to export RGBA images, then you would select Matte. See [Exporting RGBA Image Files](#) on page 248.
- 3 Select Clip to export an entire clip, or Range to export a range of frames in a clip.
- 4 If you are exporting an entire clip, select the clip that you want to export. Otherwise, continue to the next step.
- 5 If you are exporting a range of frames in a clip, select the first frame in the range, then select the last frame in the range.
The Export Image menu appears.

NOTE When the range of exported frames appears in an image directory, the sequential numbers appended to the filename are based on the frame position number from the source clip.

- 6 In the file browser, browse to the directory where you want to export the clip.
- 7 From the File Format box, select the export file format.



- 8 Optional: Change the default file extension.
- 9 To change the name of the exported image file, enter a name in the Name field.



NOTE To avoid filename compatibility issues upon export, underscores will be substituted in your filename in place of any of the following characters: ` # ~ @ \$ % ^ & * () [] { } < > \ | / ! ? , ; : ' "

- 10 In the Frame/Clip box, specify whether you are exporting a single frame or a clip.
- 11 Adjust any other parameters for file numbering, compression settings, resizing options, or to use a predefined LUT. See [Export Options Group](#) on page 238, [Quality Group](#) on page 240, or [Resizing Group](#) on page 240.
- 12 To generate thumbnail proxies for the file browser, select an option from the Proxy Generation box. See [Proxies Group](#) on page 243.

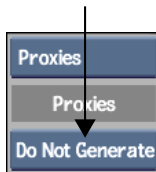

13 Click Export.

The files are generated and saved to the desktop.

To export an image file from the clip library:

1 Open the clip library containing the clip that you want to export.

2 Select the clip.

3 Click Export Image.

The Export Image menu appears.

4 In the file browser, browse to the directory where you want to export the clip.

5 From the File Format box, select the export file format.



6 Optional: Change the default file extension.

7 To change the name of the exported image file, enter a name in the Name field.



NOTE To avoid filename compatibility issues upon export, underscores will be substituted in your filename in place of any of the following characters: `# ~ @ \$ % ^ & * () [] { } < > \ | / ! ? , ; : ' " `

8 In the Frame/Clip box, specify whether you are exporting a single frame or a clip.

- Adjust any other parameters for file numbering, compression settings, resizing options, or to use a predefined LUT. See [Export Options Group](#) on page 238, [Quality Group](#) on page 240, or [Resizing Group](#) on page 240.
- To generate thumbnail proxies for the file browser, select an option from the Proxy Generation box. See [Proxies Group](#) on page 243.

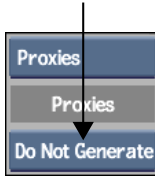

- Click Export.
The files are generated and saved in the specified location.
When the export is finished, you are returned to the clip library.

Exporting RGBA Image Files

You can export two clips (a Front clip and a Matte clip) as a single file with an embedded alpha channel. This exported file can then be used as a layer in other compositing or editing applications.

To export an RGBA file:

- Open the clip library containing the clip that you want to export.
You can also do this from the desktop. See [Exporting Image Files](#) on page 245.
- Select the Front clip.
- While holding down the **Ctrl** key, select the Matte clip (this is to be exported as the alpha channel).
- Click Export Image.
The Export Image menu appears.
- In the File Format box, select a file type that supports an alpha channel (such as Targa).
- Set the path and filename for the exported file.

NOTE To avoid filename compatibility issues upon export, underscores will be substituted in your filename in place of any of the following characters: `# ~ @ \$ % ^ & * () [] { } < > \ ! / ! ? , ; : ' " `

- 7 Set any additional export options. See [About the Export Image Menu Options](#) on page 237.
- 8 Click Export.
An RGBA file is created from the front clip and the matte clip.

Exporting DPX Files

You can export DPX files while taking advantage of all their inherent properties, such as LUTs and DPX Transfer Characteristics.

To export a DPX file:

- 1 Open the clip library containing the clip that you want to export.
You can also do this from the desktop. See [Exporting Image Files](#) on page 245.
- 2 Select the clip that you want to export and click Export Image.
The Export Image menu appears.
- 3 In the file browser, browse to the directory to which you want to export the clip.
- 4 From the File Format box, select DPX.

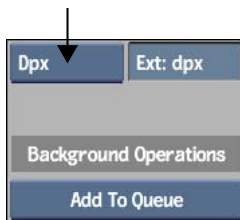

- 5 To change the name of the exported DPX file, enter a name in the Name field.



NOTE To avoid filename compatibility issues upon export, underscores will be substituted in your filename in place of any of the following characters: ` # ~ @ \$ % ^ & * () [] { } < > \ | / ! ? , ; : ' "

- 6 Specify whether you are exporting a single frame or a clip in the Frame/Clip box.
- 7 Enable Use Clip TC Names, if you would like to use the timecode contained in your clip to number the exported files.
- 8 Adjust any other file numbering parameters. See [Export Options Group](#) on page 238.
- 9 From the Bit Depth box, select a bit depth value.



DPX files can be exported as 8-bit, 10-bit, or 12-bit clips.

- 10 To use a predefined LUT, load it with the Use LUT button. See [Applying a LUT on Import or Export](#) on page 744.
- 11 Adjust any other parameters for resizing options. See [Resizing Group](#) on page 240.
- 12 Select a DPX Transfer Characteristic.

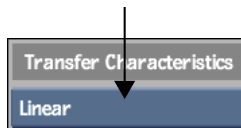

This is used to identify the attributes associated with a particular film or video format, such as resolution, frame rate, and colour space. The commonly used options are listed here. See [DPX Transfer Characteristics Group](#) on page 242.

Select:	For:
Unspecified	Images where the format is not specified.
Logarithmic	Negative film scanners recording status M densities.
Linear	Video images which have built-in gamma correction. This refers to images having a true linear quantization scheme (such as CG-originated material).
Printing Density	Negative film scans which use the SMPTE Printing Density settings. SMPTE Printing Densities use status M density measurements with a higher gain in the red component.

- 13 To generate thumbnail proxies for the file browser, select an option from the Proxy Generation box. See [Proxies Group](#) on page 243.
- 14 Click Export.
The DPX files are generated and saved in the specified location.
When the export is finished, you are returned to the clip library.

Exporting Video Files

You can encode clips into QuickTime. You can export files of almost any size and, depending on the QuickTime file format, you can apply variable compression rates to create video files with a suitable trade-off between image quality and file size.

If your video clip contains audio that extends before or after the video portion, ensure that the Consider Audio Head/Tail button is enabled. See [Audio Preferences](#) on page 853.

You can export QuickTime video files by adding them to the render queue and rendering them as a background process. When you export video files, the following frame size requirements must be met.

For this file type:	Frame size must be a multiple of:
QuickTime	4 (width only) for most compression schemes

NOTE If you enter an incorrect frame size in the Width or Height field in the calculator, the closest correct value below that which you entered is used.

You can also use Cleaner XL to export video file formats. The advantage of using Cleaner XL rather than native video export is that it offers a much broader range of export formats and compression options. Its export process also runs on a separate computer, which is dedicated to the encoding process. See [Exporting Media to Cleaner XL for Encoding](#) on page 264.

To export a video file:

- 1 Open the clip library containing the clip that you want to export.
You can also do this from the desktop. See [Exporting Image Files](#) on page 245.
- 2 Select the clip.
- 3 Click Export Image.
The Export Image menu appears.
- 4 In the file browser, browse to the directory where you want to export the clip.
- 5 From the File Format box, select QuickTime.

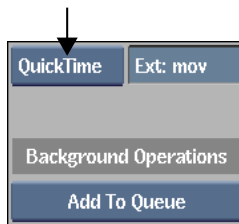

- 6 Optional: Change the default file extension.
- 7 To change the name of the exported image file, enter a name in the Name field.



NOTE To avoid filename compatibility issues upon export, underscores will be substituted in your filename in place of any of the following characters: `# ~ @ \$ % ^ & * () [] { } < > \ ! / ? , ; : ' " `

- 8 Select a video codec. If you are using DVCPProHD resolutions, note that the available progressive framerates (not fields) are listed for each.
- 9 Select a predefined codec profile for the selected video codec. See [Working with Codec Profiles](#) on page 254.
- 10 If an audio track is available, enable Include and select an audio codec.
- 11 Select a predefined codec profile for the selected audio codec. See [Working with Codec Profiles](#) on page 254.
- 12 In the Frame/Clip box, specify whether you are exporting a single frame or an entire clip.
- 13 To resize the exported video, use the resizing options, such as Width, Height, and Fit Method. See [Resizing Group](#) on page 240.
- 14 Select an option from the Add to Queue box.

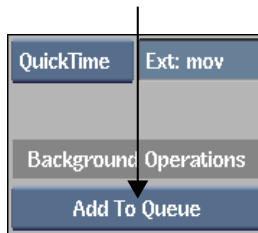

Select:	To:
Add to Queue	Add the job to the queue.
Add to Queue & Execute	Add the job to the queue and execute it automatically. If there are any jobs in progress, this job (and any others already added to the queue with the Add to Queue & Execute option) is triggered upon the completion of its predecessor.

Selecting an option from the Add to Queue box adds the export job to the Background Import/Export Queue. Video files can only be exported as a background process.

- 15 Swipe left or right to display the Import/Export Queue menu.

- 16 Select the files in the export queue that you want to export, and then click Execute Selected.

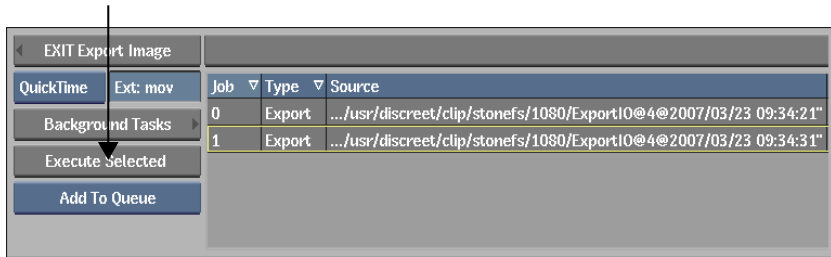

The selected clips are exported. When the export is finished, you are returned to the clip library.

Working with Codec Profiles

You can create a custom profile for a particular codec to use for specific jobs. Using the Codec Profile Editor, you can customize parameters, such as compression settings, and create a library of different codec settings that you can use anytime. Depending on the codec, the settings of some parameters may be dependent on others. In some instances, a particular field may, therefore, revert to its original setting. The codec profiles appear only for the codec for which the profile was created. You can also delete any codec profile, or load codec profiles created in another application.

To edit or create a new codec profile:

- 1 Open the Export Image menu and, from the File Format box, select QuickTime.
- 2 Click the Edit button for the video codec or audio codec that you want to modify.

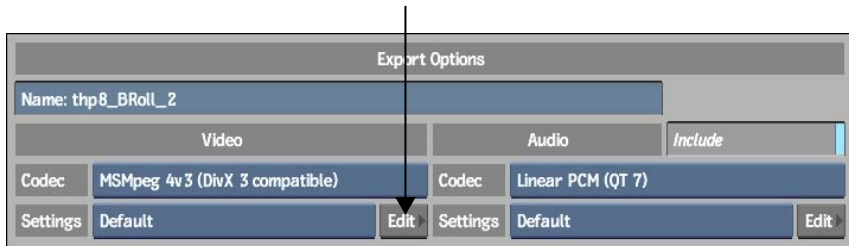

The Codec Profile Editor appears.

Codec Parameters		
Description: FFmpeg MSMpeg 4v3 (DivX 3 compatible)		
Parameter	Value	Description
▼ Frame types		
GOP size (0 = Intra only)	250	
Scenechange threshold	0	Threshold for scene change detection.Negative values mean more sensitivity (more keyframes)
Close all GOPs	FALSE	
Strictly enforce GOP size	FALSE	
▼ Rate control		
Initial RC complexity	0.0	
▼ Quantizer		
Minimum quantizer scale	2	
Maximum quantizer scale	31	
Maximum quantizer difference	3	Maximum quantizer difference between frames
Use fixed quantizer	FALSE	Use fixed quality encoding
Fixed quantizer	10	Quantizer for fixed quality encoding. Lower means better. 1 is not recommended
Quantizer compression	0.50	Amount of qscale change between easy hard scenes
Quantizer blur	0.00	Amount of qscale smoothing over time
Quantizer noise shaping	0	Choose quantization such that noise will be masked by similar-frequency content in the image
Use trellis quantization	FALSE	Use trellis quantization (improves quality)
I quantizer factor	-0.8	Quantizer factor between P-frames and I-frames.If 0 then the last P frame quantizer will be us
I quantizer offset	0.0	Quantizer offset between P-frames and I-frames
▼ Motion estimation		
Motion estimation method	Zero	
ME compare function	SAD	Motion estimation compare function.SAD: Sum of absolute differencesSSE: Sum of squared errors
Enable chroma ME compare	FALSE	
Motion estimation range	0	Motion estimation search range (0 means unlimited)
ME Theshold	0	Motion estimation threshold. under which no motion estimation is performed, but instead the use
MB decision mode	Use compare function	

- 3 If needed, select a different codec, switch between audio and video codecs, or edit a codec profile that you previously created.

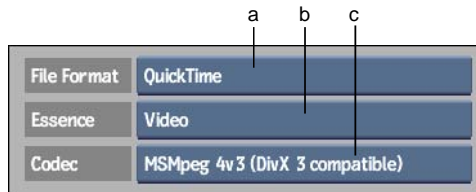

(a) File Format box (b) Essence box (c) Codec box

- 4 In the Codec Parameters list, make any changes that you need to the parameters for your specified codec.
- 5 When your modifications are done, enter a new name in the Name field, and then click Save.



Your new codec profile is saved. It appears in the list of available codec profiles when you select the codec for which the profile was created.

- 6 Click Exit Movie Presets to go back to the Export Image menu.

To delete an existing codec profile:

- 1 Open the Export Image menu and, from the File Format box, select QuickTime.
- 2 Click the Edit button for the video codec profile or audio codec profile that you want to delete.

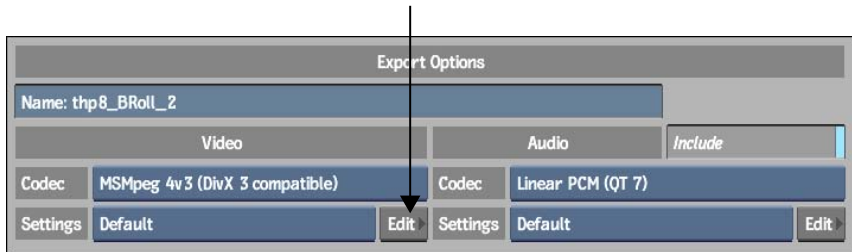

The Codec Profile Editor appears.

- 3 If needed, select a different codec, switch between audio and video codecs, or select a different codec profile to delete.

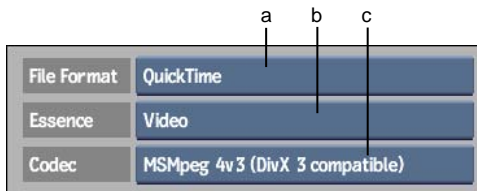

(a) File Format box (b) Essence box (c) Codec box

- 4 Click Delete.



The selected codec profile is removed, and no longer appears in the list of available codec profiles.

To load a profile:

- 1 Open the Export Image menu and, from the File Format box, select QuickTime.
- 2 Click the Edit button for the video codec or audio codec for which you want to load a profile.

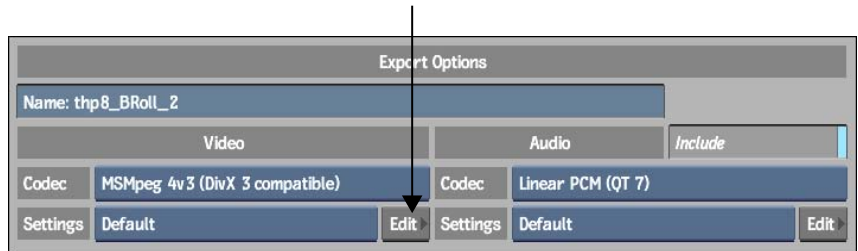

The Codec Profile Editor appears.

- 3 If needed, select a different codec or switch between audio and video codecs.

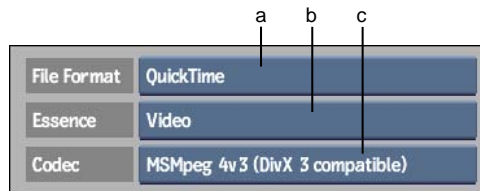

(a) File Format box (b) Essence box (c) Codec box

- 4 Ensure that the Name field is clear, and click Load.



The browser opens in the *codecprofiles* directory.

- 5 Browse to the directory containing the codec profiles that you want to load, and then click Load.

The new codec profiles now appear in the list of available codec profiles for the selected codec.

Exporting Image Files in the Background

You can export one or more image files in the background while you perform other tasks. You can export several files at once by selecting them and then processing them as a batch. You can assign different clip options to each file that you add to the queue.

To export in the background:

- 1 Open the clip library containing the clip that you want to export.
You can also do this from the desktop. See [Exporting Image Files](#) on page 245.
- 2 Select the clip.
- 3 From the Destination Library box, select a clip library.
- 4 From the Add to Queue box, select a background export option.

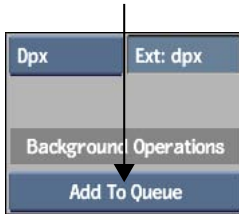

Select:	To:
Add to Queue	Add the job to the queue.
Add to Queue & Execute	Add the job to the queue and execute it automatically. If there are any jobs in progress, this job (and any others already added to the queue with the Add to Queue & Execute option) is triggered upon the completion of its predecessor.

This adds the export job to the Background Import/Export Queue. The progress of the export job is indicated in the queue.

Status:	Indicates:
Pending	Job has been added to the queue but not executed.
Queued	Job has been initialised.

Status:	Indicates:
Running	Job is being performed.
Done	Job has been executed.

- If you are adding more export jobs to the queue, click Exit Export Image to return to the clip library, select the next clip to be exported, and repeat this procedure.
- To manage the Background Import/Export Queue, see [Managing the Background Import/Export Queue](#) on page 300.

Exporting Audio Files

You can export audio from the Player or the current clip library to the filesystem as a multichannel audio file. This can be an audio-only clip or a video clip with audio. When you export audio, any uncommitted material is temporarily hard-committed (processed) and included in the exported file.

To export an audio file from the Player:

- Load the clip that you want to export into the Player.
- In the Player, select AudioDesk from the Player Menu box.
- Click Export Audio.

The Export Audio File menu appears.

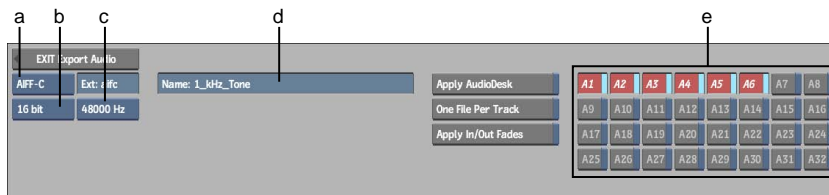

(a) File Format box (b) Audio Bit-depth box (c) Sample Rate box (d) Name field (e) Track Selection area

- Use the browser to find the directory where you want to save the audio file.
- From the File Format box, select an audio file format.

- 6 From the Sample Rate box, select the sample rate.
The available sample rates are: 48 kHz, 44.1 kHz, 32 kHz, 22.050 kHz, 16 kHz, 11.025 kHz, or 8 kHz.
- 7 Set the audio bit-depth using the Audio Bit-depth box.
The available choices are: 16 bit, 24 bit, or 32 bit (float), depending on the file format selected. The default is 16 bits.
- 8 Enter a name for the file in the Name field and press **Enter**.

NOTE To avoid filename compatibility issues upon export, underscores will be substituted in your filename in place of any of the following characters: ` # ~ @ \$ % ^ & * () [] { } < > \ | / ! ? , ; : ' "

- 9 If you are exporting MP3 files, set any of the available MP3 export options to be used for encoding.

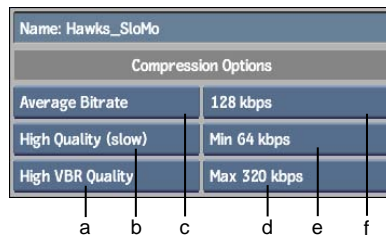

(a) VBR Quality box (b) Quality box (c) Bitrate Encoding Type box (d) Maximum Average Bitrate box (e) Minimum Average Bitrate box (f) Bitrate box

Bitrate Encoding Type box Select the type of bitrate encoding. Constant Bitrate encoding uses a single fixed bitrate for the entire file. Variable Bitrate encoding is a two-pass process of analyzing and then compressing movies to an optimal data rate. Average Bitrate encoding is similar to Variable Bitrate encoding except that it works within a set minimum and maximum bitrate.

Quality box Select the quality of the encoding algorithm. This affects the speed of the encoding.

VBR Quality box Select the number of bits used in the encoding as a factor of quality level. This affects the encoded file size.

Bitrate box Select a bitrate value.

Minimum Average Bitrate box Select the minimum bitrate to be used when Average Bitrate encoding is selected.

Maximum Average Bitrate box Select the maximum bitrate to be used when Average Bitrate encoding is selected.

- 10** If you are exporting a Broadcast Wave file, ensure that the timecode for the audio file does not start at a negative value (before 00:00:00:00).
Broadcast Wave files do not support negative timecode values. If the timecode for your audio begins before 00:00:00:00 you will need to confirm that export can proceed starting only from 00:00:00:00. The section of audio in the negative timecode area will not be exported.
- 11** Optional: Enable Apply AudioDesk.
If you enable this option, the selected clip's AudioDesk settings are applied to the exported file. For instance, if you mix multiple tracks in an audio clip to stereo, you get two audio tracks (left and right panned) in the exported file. This process is equivalent to an audio mix down.
- 12** Optional: Enable One File Per Track.
When you enable this option, one file of the specified type is exported for each audio track. Each audio track is given a distinct filename (for example, *Clip_track1.aiff*, *Clip_track2.aiff*, and so on).
- 13** Optional: Enable Apply In/Out Fades.
If you enable this option, a short fade is added at the start and end of the audio clip. The length of the in/out fades can be set in the Audio Preferences panel via the Auto Fade slider. The length is from 0 to 10ms.
- 14** Enable the audio tracks that you want to export in the Track Selection area.
- 15** Click Export.
The audio file is exported to the specified directory.

To export an audio file from a clip library:

- 1** Open the clip library containing the audio that you want to export.
- 2** Select the clip that contains the audio that you want to export.
- 3** Click Export Audio.
The Export Audio File menu appears.

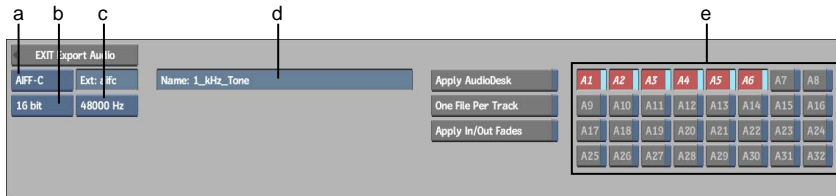

(a) File Format box (b) Audio Bit-depth box (c) Sample Rate box (d) Name field (e) Track Selection area

- 4 Use the browser to find the directory where you want to save the audio file.
- 5 From the File Format box, select an audio file format.
- 6 From the Sample Rate box, select the sample rate.
- 7 Set the audio bit-depth using the Audio Bit-depth box.
The available choices are: 16 bit, 24 bit, or 32 bit (float), depending on the file format selected. The default is 16 bits.
- 8 Enter a name for the file in the Name field and press **Enter**.

NOTE To avoid filename compatibility issues upon export, underscores will be substituted in your filename in place of any of the following characters: ` # ~ @ \$ % ^ & * () [] { } < > \ | / ! ? , ; : ' "

- 9 If you are exporting MP3 files, set any of the available MP3 export options to be used for encoding.

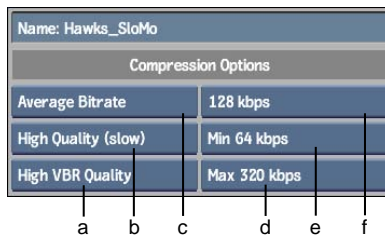

(a) VBR Quality box (b) Quality box (c) Bitrate Encoding Type box (d) Maximum Average Bitrate box (e) Minimum Average Bitrate box (f) Bitrate box

Bitrate Encoding Type box Select the type of bitrate encoding. Constant Bitrate encoding uses a single fixed bitrate for the entire file. Variable Bitrate encoding is a two-pass process of analyzing and then compressing

movies to an optimal data rate. Average Bitrate encoding is similar to Variable Bitrate encoding except that it works within a set minimum and maximum bitrate.

Quality box Select the quality of the encoding algorithm. This affects the speed of the encoding.

VBR Quality box Select the number of bits used in the encoding as a factor of quality level. This affects the encoded file size.

Bitrate box Select a bitrate value.

Minimum Average Bitrate box Select the minimum bitrate to be used when Average Bitrate encoding is selected.

Maximum Average Bitrate box Select the maximum bitrate to be used when Average Bitrate encoding is selected.

- 10** If you are exporting a Broadcast Wave file, ensure that the timecode for the audio file does not start at a negative value (before 00:00:00:00). Broadcast Wave files do not support negative timecode values. If the timecode for your audio begins before 00:00:00:00 you will need to confirm that export can proceed starting only from 00:00:00:00. The section of audio in the negative timecode area will not be exported.
- 11** Optional: Enable Apply AudioDesk.
If you enable this option, the selected clip's AudioDesk settings are applied to the exported file. For instance, if you mix multiple tracks in an audio clip to stereo, you get two audio tracks (left and right panned) in the exported file. This process is equivalent to an audio mix down.
- 12** Optional: Enable One File Per Track.
When you enable this option, one file of the specified type is exported for each audio track. Each audio track is given a distinct filename (for example, *Clip_track1.aiff*, *Clip_track2.aiff*, and so on).
- 13** Optional: Enable Apply In/Out Fades.
If you enable this option, a short fade is added at the start and end of the audio clip. The length of the in/out fades can be set in the Audio Preferences panel via the Auto Fade slider. The length is from 0 to 10ms.
- 14** Enable the audio tracks that you want to export in the Track Selection area.
- 15** Click Export.
The audio file is exported to the specified directory.

Exporting Media to Cleaner XL for Encoding

You can export clips containing images, video, and audio to be encoded by Cleaner XL into one of a variety of formats, using the Export Image menu.

You can also export media clips from the Output node in Batch for Cleaner XL encoding. See [Outputting Media to Cleaner XL](#) on page 1367.

You can export clips containing soft-imported segments, including images (SGI, DPX, JPEG, TIFF, Targa, and Cineon) and audio (AIFF and WAV), for encoding using Cleaner XL. All soft-imported images and audio in the clip must be of the same file type, for example, all TIFF files and all AIFF files. If there are different types of soft-imported files, the clip will not be encoded by Cleaner XL. In this case you should use the Stonifise tool before exporting. See [Writing Media to the Framestore Using the Stonifise Tool](#) on page 308.

NOTE The Cleaner encoding option is available only if a Cleaner XL render node has been installed on your Autodesk Backburner® Distributed Queueing System (the network rendering system). This would have been installed and configured by your systems administrator. See the *Using Cleaner XL with Autodesk Visual Effects and Finishing Applications* guide.

Note the following considerations when encoding with Cleaner XL:

- You can export clips with or without audio, as well as clips containing audio only, from the Export Image menu. The Cleaner option is not available from the Export Audio menu.
- You can output video and audio clips from the Output node in Batch for Cleaner XL encoding.
- Cleaner XL can only encode 8-bit clips. Clips of a greater bit depth are automatically resized to 8 bits upon export.
- You cannot export clips with a matte or encode RGBA files when exporting to Cleaner XL.
- You cannot export a range from a clip to Cleaner XL.

To encode media from Flame with Cleaner XL:

- 1 Open the clip library containing the clip that you want to export.
You can also do this from the desktop. See [Exporting Image Files](#) on page 245.

- 2 Select the clip. You can select a clip with or without audio, or a clip containing audio only.
- 3 Click Export Image.
The Export Image menu and file browser appear.
- 4 From the File Format Box, select Cleaner.

NOTE If you selected an audio clip to export, then Format will be automatically set to Cleaner.

The Cleaner Export menu appears.

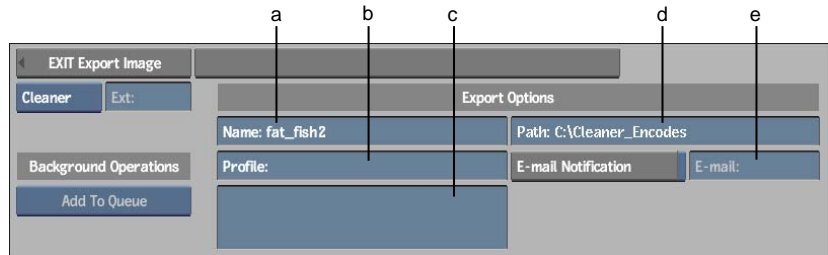

(a) Name field (b) Output Profile field (c) Output Profile Description field
(d) Destination Path field (e) E-mail Notification field

- 5 If necessary, click the Name field to activate it, and edit the name for the exported clip.

NOTE To avoid filename compatibility issues upon export, underscores will be substituted in your filename in place of any of the following characters: ` # ~ @ \$ % ^ & * () [] { } < > \ | / ! ? , ; : ' "

- 6 Confirm that the Destination Path field contains the correct path where the output job will be saved on the Cleaner XL render node. Normally, you do not need to change this. This information should have been entered by your systems administrator when Cleaner XL was installed. If the Destination Path field is not properly configured, your jobs will not be encoded. For more information, see the *Using Cleaner XL with Autodesk Visual Effects and Finishing Applications Guide*.
- 7 Click the Output Profile field.
The file browser appears displaying directories containing output profiles.

You can select an output profile, which indicates what format to encode to and related parameters. For example, you can output a QuickTime movie in NTSC for streaming to DSL.

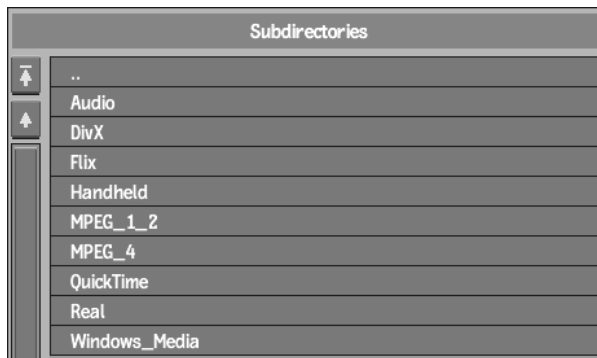

Output profiles are divided by output file format, with audio only profiles in their own directory.

- 8 Click a directory containing the format to which you want to encode. Depending on the format you select, output profiles may be further subdivided by category. The *Handheld* directory contains all the profiles for handheld devices, such as Palm® and Kinoma®. The audio directory is further subdivided by output file format, such as MP3, QuickTime, and Windows Media®. All other directories are subdivided by output format, such as Film, NTSC, or PAL, and by aspect ratio, such as 4:3 or 16:9.



(a) QuickTime Output Profiles divided by output format and aspect ratio

- 9 If necessary, select a subdirectory containing the output format to which you want to encode. Output profiles appear in the file browser.

Files (12 matches) 0 selected				
↑	QT6_NTSC_16x9_download_full_screen	12.33 KB	2006/08/08	13:35:10
↑	QT6_NTSC_16x9_download_large	12.31 KB	2006/08/08	13:35:10
↑	QT6_NTSC_16x9_download_medium	12.35 KB	2006/08/08	13:35:10
↑	QT6_NTSC_16x9_download_small	12.32 KB	2006/08/08	13:35:10
↑	QT6_NTSC_16x9_streaming_1.5Mbit_Intranet	12.36 KB	2006/08/08	13:35:10
↑	QT6_NTSC_16x9_streaming_112k_ISDN	12.37 KB	2006/08/08	13:35:10
↑	QT6_NTSC_16x9_streaming_1Mbit_LAN_T1	12.36 KB	2006/08/08	13:35:10
↑	QT6_NTSC_16x9_streaming_256k_DSL	12.37 KB	2006/08/08	13:35:10
↑	QT6_NTSC_16x9_streaming_384k_DSL	12.37 KB	2006/08/08	13:35:10
↑	QT6_NTSC_16x9_streaming_512k_DSL	12.37 KB	2006/08/08	13:35:10
↑	QT6_NTSC_16x9_streaming_56k_modem	12.35 KB	2006/08/08	13:35:10
↑	QT6_NTSC_16x9_streaming_768k_DSL	12.37 KB	2006/08/08	13:35:10

a

(a) QuickTime Output Profiles for NTSC, with a 16x9 aspect ratio

10 Select an output profile.

You are returned to the Cleaner Export menu.

The name of the output profile you chose appears in the Output Profile field, and its description appears in the Output Profile Description field.

Export Options	
Name: fat_fish2	Path: C:\Cleaner_Encodes
Profile: QT6 NTSC 16x9 streaming 512k DSL	E-mail Notification <input type="checkbox"/> E-mail: _____
QuickTime 6 for DSL or cable modem connection, hosted on a streaming media server, in widescreen (16:9) mode.	

(a) Output Profile field (b) Output Profile Description

11 Optional: Enable E-mail Notification and enter a valid e-mail address.

When the job is done, a notification message is sent to this address.

12 Click Send Job.

The job is sent to the Cleaner XL render node where it is encoded, using the parameters in the output profile that you selected, and saved in the destination folder on that render node.

TIP When encoding media files using Cleaner XL, the entire job is encoded on the same render node. When encoding a single job, no load balancing is done and additional render nodes on the Autodesk Backburner Distributed Queueing System do not increase efficiency. If you are encoding more than one job at a time, additional jobs are routed to available render nodes. This may affect your choice of output profiles, as larger output files may take a long time to encode.

Deleting Media Files From the Filesystem Via Export Image

You can use the file browser in the Export Image menu to remove image files, including soft-imported image files, from the filesystem.

To remove media files:

- 1 Open the Export Image menu.
- 2 Display the directory containing the files that you want to remove.
- 3 Select the files.
- 4 Click Remove, then click confirm.

NOTE If you remove soft-imported files, the source media is not deleted; only the reference to the clip is deleted.

Unlinking and Relinking Media and Clips



Topics in this chapter:

- [About Unlinking and Relinking Media and Clips](#) on page 269
- [Unlinking Media from Clips in the Clip Library](#) on page 270
- [Reformatting Clips](#) on page 273
- [Reformatting Examples](#) on page 278
- [Recapturing Media](#) on page 280
- [Relinking Media to Clips](#) on page 289

About Unlinking and Relinking Media and Clips

The clip library contains a suite of tools for making different versions of a project— Unlink, Relink, Reformat, and Recapture. These tools allow you to separate the media of a clip from its metadata, optionally reformat the metadata of an unlinked clip to another resolution, recapture the associated media, and then relink the metadata to the newly captured media.

You can use these capabilities for a number of purposes, for example:

- Create multiple masters by working on a project at one resolution and then reformatting it to another. You can speed up your interaction within the

application by working on the lower resolution version. You could, for example, shoot in HD or film, finish the project in SD in Flame, and output in either resolution.

- Work on proxies instead of the actual media during the course of the project. You can unlink the media from a clip but retain the proxies. When the project is complete, recapture the media at the required resolution, relink, and output as the finished version. Working on proxies provides an improved level of interactivity, particularly with projects based on high-definition media. Also, less space on the framestore is used during the project.
- Replace shots that were captured incorrectly, for example, if frames became corrupted during capture.
- Replace shots that were worked on outside Flame after being captured. For example, replace shots that were colour corrected using an image processor after the original capture.
- Move clips to a new facility. Unlink the media from clip metadata, transfer the metadata to the new facility, recapture the material at the new facility, and then relink the recaptured material to the clips.
- Unlink media from a timeline prior to archiving at the end of a project, the result being a much smaller archive. The media would need to be recaptured and relinked to the timeline when restoring the archive.
- Free up space on the framestore. Media is removed from the framestore when unlinked from a clip, given that no other clips are referencing that media. Depending on the way you manage clips on a project, this may be a feasible method of gaining framestore space.

Unlinking Media from Clips in the Clip Library

You can break the link between the media and the metadata of a clip using the Unlink tool. You can unlink the video media, the audio media, or both. When you unlink a clip's media from the metadata, all the metadata is retained. This includes tracks, layers, containers, timecodes, the tape name, dissolves, wipes, cuts, and soft effects.

When a clip is unlinked, and there is no other clip referencing the media, the media is deleted. If a source clip is used in multiple timelines and you unlink media for one timeline only, the other timelines are not affected. This ensures that you do not accidentally delete the link to another user's media.

All clips in Flame except virtual sources can be unlinked. After unlinking, you can, for some types of clips, recapture the media associated with the unlinked clip, and relink it to the clip.

You can relink the media from clips captured from a VTR and from clips imported into Flame from image and audio files. When you unlink imported clips, the original path to the image files is retained in the clip metadata, making it easier to reload the associated media. When you unlink captured video-based media, the tape name and in and out timecodes are retained in the clip metadata, allowing you to easily recapture the material associated with the metadata, and relink the material to it.

The media of clips processed in modules cannot be relinked to the clips; the same applies to hard-committed clips. In these cases, the media is flagged as un-reloadable. When unlinking from the Tools menu, you can unlink only the material that can be recaptured or you can unlink all media (including the clips processed in effects modules).

Unlinked clips can be archived and transferred using Wire, and they can be used when exporting to an EDL.

You can unlink entire timelines from the clip library or selected timeline segments directly on the timeline.

To unlink media:

- 1 Open the clip library containing the clips from which you want to unlink the media.
- 2 In the Clip Library menu, click Tools.
- 3 From the Tools menu, choose Unlink/Relink.
- 4 If necessary, enable Unlink to display the Unlink Media controls.



(a) Unlink Media box (b) Media Type box (c) Limit Unlink box (d) Limit Resolution box

- 5 Select the clips that you want to unlink.

- 6 From the Media Type box, select the type of media that you want to unlink from the clip.

Select:	To:
Video Only	Unlink the video media from the clip metadata.
Audio Only	Unlink the audio media from the clip metadata.
Video & Audio	Unlink the audio and video media from the clip metadata.

NOTE If you select Video Only or Audio Only on a clip containing both types of media, you can perform the unlink operation on the remaining media in the unlinked clip at a later time.

- 7 From the Limit Unlink box, select an option.

Select:	To:
Unlink Reloadable	Unlink the media only from clips whose media can be recaptured or reimported and relinked to the clip. Clips created in effects modules are not unlinked.
Unlink All	Unlink the media from all selected clips regardless of whether the media can be recaptured and relinked to the clip.

- 8 From the Limit Resolution box, select an option.

Select:	To:
All Resolutions	Select clips of any resolution.
Specified Res	Specify a framerate and a resolution. Only clips that match the selected criteria are unlinked.

- 9 From the Unlink Media box, select an option.

Select:	To:
Unlink	Unlink the media from the metadata.
Unlink High Res	Unlink the media from the metadata but retain the proxies. Proxies must be generated prior to unlinking with this option.

- 10** Confirm the action. If there are multiple clips, you will be prompted to apply the changes to all the clips or each one individually.

The media is unlinked from the metadata for the selected clips. The appearance of the unlinked clip depends on the unlink options you picked:

- If you selected Unlink with Video or Video & Audio, the label “Unlinked Media” appears on black frames.
- If you selected Unlink with Audio, the video images appear on the frames, with the label “Unlinked Audio” superimposed on them.
- If you selected Unlink High Res, the proxy image appears if Proxy resolution is set for the clip in the Player. See [Setting Playback Resolution and Mode](#) on page 99. If Full Res resolution is set in the Player, the words “Unlinked Hires” appear on black frames.
- If only some segments were unlinked, the untouched media is unaffected by the change.



Reformatting Clips

Whether you want to create final masters of your project in different resolutions or simply increase your speed of interactivity by working in a resolution lower than that of the final version, the Reformat tool can facilitate your work by simplifying the steps involved.

You can change the metadata resolution parameters of unlinked clips using the Reformat tool. For example, you can reformat a clip to another specified frame size, framerate, or scan mode. You can then recapture media of the specified format and relink it to the clip. For instance, assume your project was shot in HD 59.94i (16x9), down-converted to NTSC at 16x9 aspect ratio and then brought into Flame. You perform your online editorial with the SD material and in the middle of the project, you learn that you need to deliver an HD version. The Reformat tool allows you to select all the SD source clips

and change the metadata into HD clips. Soft effects are scaled automatically to the new format. You can then recapture the material using the HD tapes and link the HD material to the reformatted clips.

If the clip that you are unlinking is based on a timeline that contains some segments that are not unlinked, the media of these segments will also be reformatted and, if needed, timewarped. You can specify the fit method for this media. Usually you can use this reformatted media as a guide only, replacing it with a version created at the appropriate resolution at a later time.

NOTE When you want to change the resolution parameters of regular clips that have no unlinked media from the clip library, use the Resize tool in the Clip Library menu. See [Resizing on Import, Export, or in a Clip Library](#) on page 665.

In general, use the following workflow when reformatting unlinked clips.

Step:	Refer to:
1. Verify whether or not the clip contains module-processed segments. If so, decide on the method you will use to replace the material for these segments.	Handling Clips with Processed Effects on page 275.
2. Unlink the edited clips. All the editorial decisions, layers, soft effects, and transitions are conserved in the metadata.	Unlinking Media from Clips in the Clip Library on page 270.
3. Reformat the clips to the appropriate resolution and framerate. Apply a fit method to existing media on the timeline.	Reformatting Unlinked Clips for Recapture on page 277.
4. Recapture the clips using the appropriate material.	Recapturing Media on page 280.
5. Relink the newly captured media to the existing metadata.	Relinking Media to Clips on page 289.
6. Capture the source material for module-processed segments at the appropriate resolution, reapply the setups, reprocess, and replace the low-quality version.	Handling Clips with Processed Effects on page 275.

You have many options for changing the resolution, including setting a custom resolution. The following table lists some typical resolution conversions you can make to the metadata.

Convert from:	To:
NTSC 4x3	NTSC 16x9
NTSC (4x3 or 16x9)	HDTV 720P
NTSC (4x3 or 16x9)	HDTV (23.976p)
NTSC (4x3 or 16x9) (24p)	HDTV 59.94i (with pulldown removal)
NTSC (4x3 or 16x9) (24p)	HDTV (23.976p)
PAL 4x3	PAL 16x9
PAL (4x3 or 16x9)	HDTV 25p / 50i
PAL or NTSC	Film 2K (scanned files)

See [Reformatting Examples](#) on page 278.

Handling Clips with Processed Effects

Media processed in modules cannot be recaptured and relinked to an unlinked clip. If your timeline contains segments comprised of processed clips, and your project workflow involves unlinking, reformatting, and, later, recapturing media, you will need to manually convert the processed shots to the required resolution. Use one of the following suggested workflows to convert these shots.

Replacing Shots After Recapturing the Timeline

This workflow is suitable for situations where you want to retain and output two versions of a project.

To replace module-processed shots after recapture:

- 1 Create the module-based effects on the SD version and process.
- 2 Save the setups.
- 3 Add the shots to the timeline.

- 4 When the project is complete, save the current version of the timeline (for example, PAL or NTSC), and output as needed.
- 5 Unlink a second copy of the timeline using Unlink Reloadable. The processed segments will be ignored.
- 6 Reformat the timeline to the new resolution. Select a fit method for resizing the media on the timeline; you can use it as a reference prior to replacing it.
- 7 Capture the material of the second resolution and link it to the clip.
- 8 Import the DPX material or capture the HD source material required for the processed shots.
- 9 Bring the DPX or HD sources into the appropriate modules, apply the setups to this material, process, and replace on the timeline. The timeline is now ready for output at the second resolution.

Replacing Shots Prior to Recapturing the Timeline

This workflow is only suitable for projects where a single final resolution is planned.

To replace shots prior to recapture:

- 1 Perform the module-based effect on the SD version and process. Save the setups.
- 2 Import the DPX material or capture the video material at the required resolution for the shot.
- 3 Reapply the setup in the module and process.
- 4 Replace the shot on the timeline.
- 5 When the project is complete, unlink the timeline, choosing Unlink Reloadable. The processed shots will be ignored.

A variation on this workflow would be to create the module-based effects in the final resolution, avoiding the need to reapply the setups, reprocess, and replace the shot. However, you would need to have the final resolution material for those shots available at an earlier point in the project.

To create effects on the final resolution material:

- 1 When you know you will work in a module, import the DPX version or capture the HD version of the shot.
- 2 Perform the effect on the DPX version or HD version and process.
- 3 Replace the shot on the timeline.
- 4 When the project is complete, unlink the timeline, choosing Unlink Reloadable. The processed shots will be ignored.
- 5 Reformat the clip to the new resolution. Make sure the resize settings are exactly that of the final. They will therefore not affect the module-processed media.
- 6 Recapture the remaining material and relink.

Reformatting Unlinked Clips for Recapture

Reformat the metadata of unlinked clips using the Reformat tool.

To reformat unlinked clips prior to recapturing the media:

- 1 Open the clip library containing the unlinked clips you want to reformat.
- 2 Select the unlinked clips you want to reformat.
- 3 Click Tools to display the Tools menu.
- 4 From the Tools menu, choose Unlink/Relink.
- 5 Click Reformat.

The Reformat controls appear.

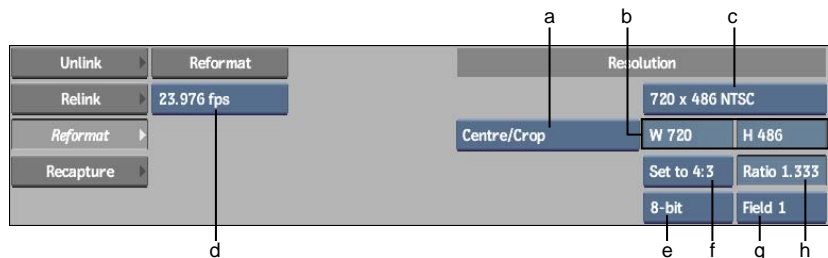

- (a) Fit Method box (b) Width and Height fields (c) Resolution Presets box
(d) Frame Code Mode box (e) Bit Depth box (f) Aspect Ratio Presets box (g) Scan Mode box (h) Aspect Ratio field

- 6 Specify the destination resolution by doing one of the following:
 - Select a preset from the Resolution Presets box.
 - Specify the dimensions using the Width and Height fields.
- 7 From the Frame Code Mode box, set the framerate and drop frame mode as needed.

If you have a clip that contains some linked media and some unlinked metadata, when you change the frame code mode such that the duration of the clip is affected, the unlinked metadata and linked media are treated differently. The linked media is timewarped to accommodate the new duration. For unlinked metadata, if more material is needed to accommodate the change in duration, it is input when the clip is recaptured. Effects will look identical, although the timing of the clip will be adjusted.
- 8 Set the aspect ratio, bit depth, and scan mode as needed.
- 9 If your clip contains video tracks or segments that still contain media (for example, module-processed shots), select a resize fit method from the Fit Method box.

NOTE This parameter only affects existing media in the clip, not the media that is later recaptured and relinked to the clip.

- 10 Click Reformat and confirm the action. If there are multiple clips to confirm, you can click Confirm All to confirm them all or click Confirm for each clip.

The clip metadata for the selected clips is updated to the specified values. Any existing media is also converted and resized using the specified fit method. You can now recapture the media associated with these clips in the appropriate format.

Reformatting Examples

The following are suggested procedures for reformatting a project to a different resolution upon its completion.

To reformat a project from SD (NTSC or PAL) to HD:

- 1 Shoot the project at an HD resolution.
- 2 Convert the material to SD using, for example, a VTR.

- 3 Capture the SD material into Flame.
- 4 Complete the project in SD.
- 5 When the project is complete, unlink the media.
- 6 Reformat the unlinked clip to HD.
- 7 Recapture the original HD material.
- 8 Relink the clip with the HD media.

To reformat a project from SD (NTSC or PAL) to DPX:

- 1 Shoot the project on film.
- 2 Use a telecine to convert the material to SD.
- 3 Bring the SD version into Flame.
- 4 Complete the project in SD.
- 5 When the project is complete, unlink the media.
- 6 Reformat the timeline clip to 2K. Soft effects are scaled automatically.
- 7 Recapture using the Select Convert Tape to Files option.
- 8 Access the DPX material corresponding to the SD version shots and reload.
- 9 Relink.

To reformat a project from NTSC 24p to HD 24p:

- 1 Shoot the project at 1080 24p.
- 2 Down-convert the material to NTSC with pulldown added, using tape-to-tape transfer or telecine.
- 3 Capture the material into Flame, removing pulldown. The reel information in the clip metadata shows that the material originated as 30 fps interlaced. It contains dual timecode.
- 4 Work on the project at 24p.
- 5 When the project is complete, unlink the media.
- 6 Reformat the timeline clip to HD 1080 24p.
- 7 Recapture and relink the HD 1080p material.

To reformat a project from NTSC 30i to HD 24p:

- 1 Shoot the project at 1080 24p.
- 2 Down-convert the material to NTSC with pulldown added, using tape-to-tape transfer or telecine.
- 3 Capture the material into Flame.
- 4 Work on the project in NTSC 30 fps.
- 5 When the project is complete, unlink the media.
- 6 Reformat the timeline clip to HD 1080 24p.
- 7 Recapture and relink the HD 1080p material.

To reformat a project from PAL to HD 24p:

- 1 Shoot the project at 1080 24p.
- 2 Convert the material to PAL using a telecine.
- 3 Capture the material into Flame.
- 4 Work on the project at 24p or in PAL.
- 5 When the project is complete, unlink the media.
- 6 Reformat the timeline clip to HD 1080p.
- 7 Recapture and relink the HD 1080p material.

Recapturing Media

You can recapture unlinked media that originates from VTR sources, image files, audio files, and film scanners. The media can be of the same resolution as the originally captured media or of a different resolution. If you are recapturing media of a different resolution, you must first reformat the unlinked clip to the new resolution. See [Reformatting Unlinked Clips for Recapture](#) on page 277.

When you recapture media, Flame checks that the tape name and the duration of all shots exactly matches that of the originally captured media. Usually the timecode matches as well; however, you have the option of slipping the start timecode for individual tapes recaptured from a VTR. Similarly, when reloading image files, you can “swap” any file for another as long as it has the exact duration of the original file. This is useful when you want to replace one shot

with another. For example, if a CG shot was re-rendered, you can recapture the re-rendered shot in place of the original. You can also change the tape name associated with a clip. In the case of audio files, you can only recapture the original audio — you cannot “swap” an audio file for another audio file.

NOTE You can slip the source timecode on a tape to match a new tape. This is useful when performing a new film transfer at another timecode. Do this using the Tape list.

You can recapture and relink media from a different type of source than the original. For example, if you transfer film material to a VTR and then capture it from the VTR and use this format to work in Flame, you can later import DPX files of the same material and link this format to your timeline. The files can be of any format supported for import into Flame. See [Supported File Formats](#) on page 194.

You can recapture unlinked media from a clip that contains some unlinked media and some media still present in the clip. For example, you can recapture a clip with only the audio unlinked or with timeline segments containing clips processed in modules. When you recapture, Flame only recaptures the unlinked media. The segments or entire tracks that contain media are ignored. If proxies are defined for the project, they are regenerated on recapture.

NOTE Recapturing captures all the heads and tails in an unlinked clip. If needed, you can consolidate an unlinked clip prior to recapture.

When you recapture, one clip per event is placed in a reel, similarly to the way captured clips are placed in a reel when auto-capturing an EDL. By default, a reel named “Recapture” is created in the clip library for the events, but you can specify a different reel name or an existing reel.

After you have recaptured the media, you must link it to the unlinked clip. You can do this as the last step of the recapture process or from the clip library at a later time.

Recapturing Media from a VTR

Recapture video-based media associated with unlinked clips using the Recapture tool.

To recapture media from a VTR:

- 1 Open the clip library containing the unlinked clips for which you want to recapture media.

- 2 Select the unlinked clips.
- 3 Click Tools to display the Tools menu.
- 4 From the Tools menu, choose Unlink/Relink.
- 5 Click Recapture.

The Recapture screen appears.

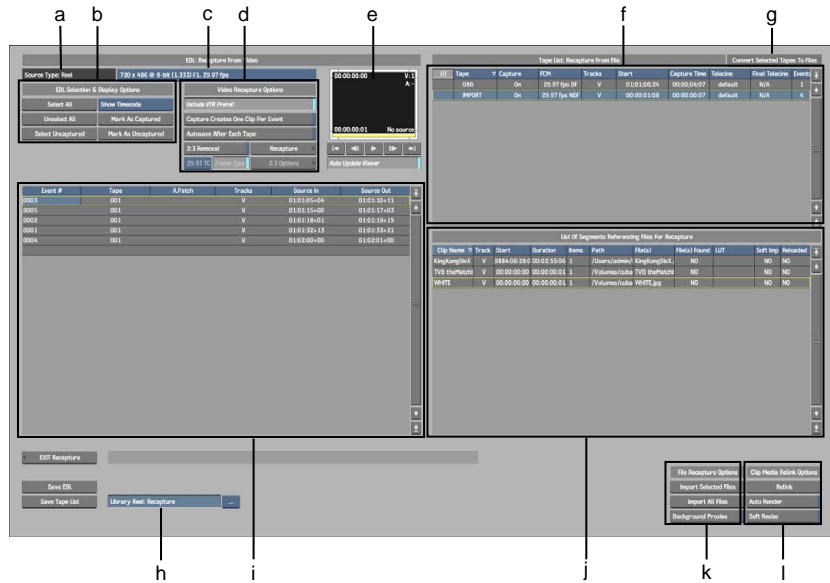

(a) Source Type label (b) EDL Selection & Display Options (c) Source Resolution box (d) Video Recapture Options (e) Auto Update Viewer (f) Tape list (g) Convert Selected Tapes To Files (h) Library Reel box (i) EDL list (j) Imported Clips list (k) File Recapture Options (l) Clip Media Relink Options

The Recapture screen contains the following three list areas:

- The Tape List contains the tape names for the media that you recapture from a VTR.
- The Sources List contains the media events.
- The Imported Clips List contains the file-based media associated with the unlinked clip. The Source Type label indicates the origin of the media. All this information is read from the clip metadata.

- 6 Optional: Change the library reel where you want to place the captured material by selecting one from the Library Reel box or create one by

clicking in the Library Reel Name field. By default, the captured clips will be placed in a reel called “Recapture”.

- 7 Optional: From the Source Resolution box, select the resolution of the device from which you are capturing material.

If your timeline clip uses sources of differing resolutions, the resolutions are listed in the Source Resolution box. This box acts as a filter on the Tape list and Event list. Only those tapes or events of the currently displayed resolution are listed.

The tapes containing the material of the specified resolution are displayed.

- 8 If the list contains any tapes that you do not want to recapture during this session, click in the Capture field of the tape and drag to the left or right.

The value changes from On to Off.

- 9 Set any options as needed. See [About the Import EDL Menu](#) on page 322.

- 10 Optional: Slip the start timecode of one or more tapes by dragging in the Start field of a tape in the Tape list.

- 11 Select the events that you want to recapture.

Do any of the following:

- To select a single event, click the event number entry. Click the event number entry of another event to unselect the first entry.
- To select a range of events, hold **Shift**, select an event, and click the last event in the range that you want to select. You can also click and drag to select a range of events.
- To add to a range of events, hold the **Ctrl** key or the pen button when you select an event.
- To select all events, use the Select All or Unselect All buttons.
- To select only the uncaptured events, click Select Uncaptured.

NOTE When no event is selected, all events in the EDL are recaptured.

- 12 To remove pulldown on capture, enable 2:3 Removal and set options as needed.

You can remove pulldown on recapture regardless of whether pulldown was removed when the original material was captured. See [Capturing Film-Based Media with 2:3 Pulldown Using EDLs](#) on page 708.

- 13 Optional: If you want to generate proxies of the media in the background, enable Background Proxies.
- 14 Click Recapture.
The Auto-Capture menu appears.
- 15 Set menu options as required and capture the material. See [Auto-Capturing an EDL](#) on page 380.

NOTE In the Auto-Capture menu, do not change the aspect ratio, bit depth, or scan mode. The default values in these fields currently match the metadata in the selected unlinked clips and they must be matched in order to relink the material with the unlinked clip after the capture.

- 16 Click Exit Auto-Capture to return to the Recapture menu.
All captured events have a small x to the right of the event number.
- 17 View the captured material in the Recapture Viewer to make sure that the capture was successful.
- 18 Enable Auto Render if you want to re-render all timeline soft effects and transitions.
- 19 Optional: If the material needs to be soft-resized, enable Soft Resize.
This is useful, for example, when importing a 720x486 clip into a 720x480 project. See [Resize](#) on page 663.
- 20 Click Relink.
The captured media is relinked with the unlinked clips. If you enabled Auto Render, timeline soft effects are re-rendered.
- 21 Click Exit Recapture to return to the clip library.
The relinked clip is located in the reel specified in the Library Reel box.

Reloading Imported Files

Reload file-based media associated with unlinked clips using the Recapture menu.

To reload imported clips:

- 1 Open the clip library containing the unlinked clips for which you want to reload media files.

- 2 Select the unlinked clips.
- 3 Click Tools to display the Tools menu.
- 4 From the Tools menu, choose Unlink/Relink.
- 5 Click Recapture.

The Recapture screen appears.

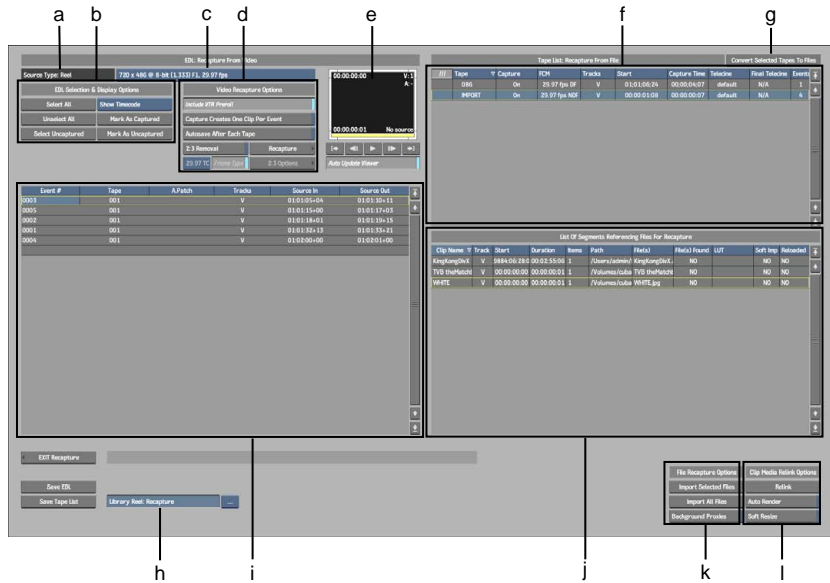

(a) Source Type label (b) EDL Selection & Display Options (c) Source Resolution box (d) Video Recapture Options (e) Auto Update Viewer (f) Tape list (g) Convert Selected Tapes To Files (h) Library Reel box (i) EDL list (j) Imported Clips list (k) File Recapture Options (l) Clip Media Relink Options

The Imported Clips List lists files that you import into Flame. This information is read from the clip metadata.

- 6 Check the Files Found column. All entries marked YES can be reloaded from the current path, or a different path and filename can be specified. For any entries marked NO, a path must be specified.
- 7 Specify the path for any entries as required by clicking the Path field of the entry.
- 8 Optional: In the Soft Import field, select YES if you want to soft-import the files. See [About Soft-Import and Proxies](#) on page 199.

- 9 Optional: Select an alternative file in the File Name field of the entry.
- 10 Optional: Associate a LUT with the selected file by clicking the LUT field of the entry. See [Applying a LUT on Import or Export](#) on page 744.
- 11 Optional: If you want to generate proxies of the media in the background, enable Background Proxies.
- 12 From the File list, select the file entries that you want to reload.
If you are reloading all the clips, you do not need to select any entries.
- 13 Click Import Selected Files or Import All Files.
The files are loaded.
- 14 View the loaded files in the Recapture Viewer to make sure the files were loaded successfully.
- 15 Enable Auto Render if you want to re-render all timeline soft effects.
This is done during the relink process executed in the next step.
- 16 Optional: If the material needs to be soft-resized, enable Soft Resize.
This is useful, for example, when importing a 720x486 clip into a 720x480 project. See [Resize](#) on page 663.
- 17 Click Relink to relink the captured media with the unlinked clips.
The specified files are linked with the unlinked clips. If Auto Render was enabled, timeline soft effects are re-rendered.
- 18 Click Exit Recapture to return to the clip library.
The reel specified in the Library Reel box contains a clip with the relinked media and the recaptured sources.

Loading Image Files into Video-Based Sources

When recapturing unlinked media, you can substitute files such as DPX images files for sources on a timeline that originated as video. This is useful when you want to conform an SD clip that was captured from video tapes to film scanned material. The requirements to accomplish this are as follows:

- The unlinked clip must be reformatted to the resolution and file format parameters (such as framerate and scan mode) of the files you are loading. See [Reformatting Clips](#) on page 273.

- The duration of each file you are loading must be identical to the duration of the clip or segment it is replacing.

NOTE This procedure is not supported for audio files.

To load files into video-based sources:

- 1 Display the clip library containing the unlinked clips for which you want to recapture media.
- 2 Select the unlinked clips.
- 3 Click Tools to display the Tools menu.
- 4 From the Tools menu, choose Unlink/Relink.
- 5 Click Recapture.

The Recapture screen appears.

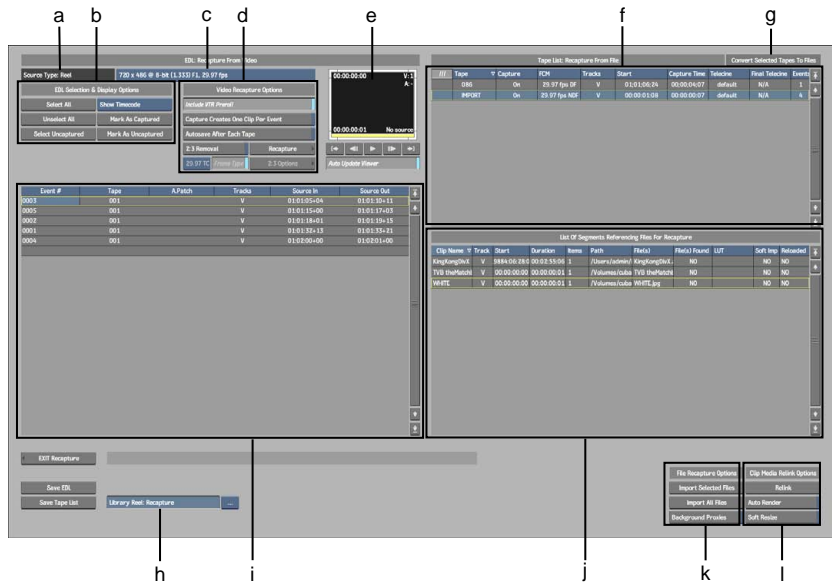

(a) Source Type label (b) EDL Selection & Display Options (c) Source Resolution box (d) Video Recapture Options (e) Auto Update Viewer (f) Tape list (g) Convert Selected Tapes To Files (h) Library Reel box (i) EDL list (j) Imported Clips list (k) File Recapture Options (l) Clip Media Relink Options

The tapes corresponding to the video-based unlinked media are listed in the Tape list. The Source Type label indicates the origin of the media. This information is read from the clip metadata.

- 6 By default, the captured clips will be placed in a reel called “Recapture”. You can change the library reel where you want to place the captured material by selecting one from the Library Reel box or create one by clicking the Library Reel Name field.

- 7 Optional: From the Source Resolution box, select the resolution of the device from which you are capturing material.

If your timeline clip uses sources of differing resolutions, the resolutions are listed in the Source Resolution box. This box acts as a filter on the Tape list and Event list. Only those tapes or events of the currently displayed resolution are listed.

The tapes containing the material of the specified resolution are displayed.

- 8 Select the tapes containing events for which you want to load equivalent files.

NOTE The status of the Capture field does not affect the selection.

- 9 Click the Convert Selected Tapes to Files button.

The events belonging to the selected tapes appear in the File list. No path or filenames currently appear, but the reel name is placed in the path field temporarily, for reference. Next, you set the correct path and filename for the file corresponding to each video-based event.

- 10 Specify the path for any entries as required by clicking the Path field of the entry.
- 11 Optional: Select an alternative sequence of files in the File Name field of the entry.
- 12 Optional: Associate a LUT with the selected file, by clicking the LUT field of the entry. See [Applying a LUT on Import or Export](#) on page 744.
- 13 Optional: If you want to generate proxies of the media in the background, enable Background Proxies.
- 14 Select the file entries that you want to reload from the File list. If you are reloading all the clips, you do not need to select any entries.
- 15 Click Import Selected Files or Import All Files.
The files are loaded.

- 16 View the loaded files in the Recapture Viewer to make sure the files were loaded successfully.
- 17 Enable Auto Render if you want to re-render all timeline soft effects.
- 18 Optional: If the material needs to be soft-resized, enable Soft Resize. This is useful, for example, when importing a 720x486 clip into a 720x480 project. See [Resize](#) on page 663.
- 19 Click Relink to relink the captured media with the unlinked clips. The loaded files are linked with the unlinked clips. If Auto Render was enabled, timeline soft effects are re-rendered.
- 20 Click Exit Recapture to return to the clip library. The reel specified in the Library Reel box contains a clip with the unlinked media and the captured sources.

Relinking Media to Clips

After you recapture media for an unlinked clip, you must link it to that clip to associate it with the clip metadata. You can relink recaptured image file imports, audio file imports and VTR-captured clips. Module-processed clips are tagged as un-reloadable, and cannot be recaptured or relinked.

You can link the captured media directly from the Recapture menu after recapturing it, or from the clip library using the Relink tool. In most instances, it is more convenient to relink directly after recapture from the Recapture menu. When you relink the media to the clip from the Recapture menu, an assembled clip is placed in the specified reel. This clip is given the same name as the original unlinked clip. The original unlinked media clip is kept in its original location. This clip can be used again for recapturing.

Use the Relink tool in the clip library to relink media to an unlinked clip when it is not convenient to do so from the Recapture menu. When relinking from the clip library, the media and metadata you are relinking must be located in the same reel.

To relink in the clip library:

- 1 If the unlinked clip metadata that you want to relink with recaptured media is not located in the reel containing the recaptured media, move it there by dragging and dropping.
- 2 Select the unlinked clip.

- 3 Click Tools to display the Tools menu, then choose Unlink/Relink.
- 4 Click Relink.
The Relink menu opens.
- 5 To account for possible linking problems that may arise when importing files using an EDL, select an option from the Relink Mode box.

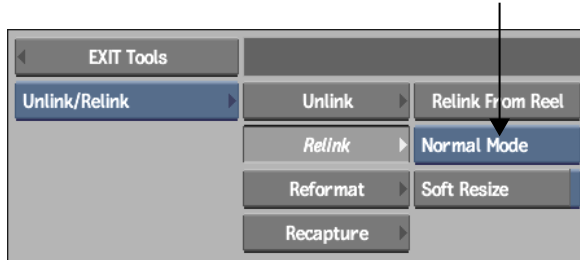

Select:	To:
Normal Mode	Relink clip metadata to media based on the tape name and timecode only.
Strict Mode	Relink clip metadata to media based on the tape name and timecode, as well as the filename. This value is used by default.

NOTE When you relink using the Recapture module, files are always searched using Strict mode.

- 6 Optional: Enable Soft Resize. See [Resize](#) on page 663.
- 7 Click Relink From Reel.
All the captured clips in the reel that are associated with the original clip are relinked to it.

Processing and Publishing

12

Topics in this chapter:

- [About Processing and Publishing](#) on page 291
- [Types of Publishing](#) on page 292
- [About the Publish Tool](#) on page 294
- [Publishing a Clip Using the Publish Tool](#) on page 296
- [Publishing in the Background](#) on page 298
- [Managing the Background Import/Export Queue](#) on page 300
- [Processing Soft Effects and Batch FX](#) on page 302
- [Processing Clips and Proxies](#) on page 305
- [Processing in Modules](#) on page 307
- [Writing Media to the Framestore Using the Stonifise Tool](#) on page 308
- [Using the Stonifise Tool in the Background](#) on page 309
- [Consolidating Clips](#) on page 311
- [Committing Soft Clips, History, or Audio](#) on page 312
- [Compacting Clips](#) on page 313

About Processing and Publishing

Processing is a convenient means of ensuring real-time playback when creating complex effects. Publishing provides an efficient way to handle media that resides outside the framestore, on the Autodesk or shared storage device. Before

using the process and publish features, it is important to understand some underlying concepts and principles.

In the context of processing and publishing, you are dealing with media and clips.

The term *media* refers to images, video, or audio that can reside either on the Autodesk storage device or outside, on the shared storage.

The term *clip* refers to a collection of media-specific metadata that is native to Autodesk products and that, unlike media, cannot be stored in the shared storage. This includes any soft effects, timewarps, or dissolves that are applied to the existing media, but not yet processed.

A clip residing in Autodesk storage can reference media that is stored outside the framestore. This type of clip is referred to as a *soft-imported clip*.

A *processed clip* consists of new media that incorporates whatever soft effects, timewarps, and dissolves that you applied. Processing renders the effects and writes new images to storage. In situations where you are not achieving real-time playback, you can selectively process elements in the timeline (or the whole timeline) to restore it. Soft effects remain editable after processing; that is, the processing does not remove the “soft” part of the effect.

A *published clip* consists of media that resides outside of Autodesk storage (in a shared storage device or area) and a soft-imported clip that references that media. The original clip from which you published the media is not linked to the published media or soft-imported clip. Publishing a clip is similar to a regular export operation.

If you have a Burn license, you can take advantage of the remote rendering system to process clips containing soft effects, timewarps, and dissolves.

You can save time by applying effects to proxies, and then processing only the proxies rather than the full-resolution images. You can refine an effect using proxies and process the full-resolution images when you are finished.

You can also write media to the framestore to make your version inaccessible in the shared storage area. To do this, you can use the Stonifise tool. This tool converts the soft-imported clips into regular clips that no longer reside on the shared storage but are written to Autodesk storage.

Types of Publishing

You can perform three types of publishing: Simple, Complex, or Flatten. Each type is suited to a different publishing scenario.

Simple Publish Creates a continuous file sequence on the shared storage, in which all effects are hard committed. The resulting clip in the clip library is also continuous and is linked to the published media on the shared storage.

Complex Publish Creates a file sequence for each segment of the clip, with only the source media being published. The resulting clip has the same structure as the original clip except that the media is saved to a shared storage volume and is unmanaged. It is no longer managed on the direct attached storage array. Neither soft effects nor transitions are committed for the clip or for the sequence of files.

Flatten Publish Flattens the media into a single video layer. The published media includes head and tail frames (based on the value set in the Handles field). All effects such as wipes and timewarps are committed. Dissolves and cuts are not committed. When you use Flatten Publish, an EDL is generated to maintain the dissolve and cut transitions created in the Autodesk Visual Effects and Finishing application. The published media is divided into segments to maintain the unrendered dissolve and cut information. To render the dissolves and transitions, use the EDL.

Use this publish option if you are publishing media that you will be using in Autodesk Lustre.

NOTE Performing Flatten Publish of clips containing keycode preserves the same keycode in the exported DPX files.

When publishing using any of the three methods, the files generated are as follows:

- A new clip is published in the clip library, named *<clip_name>_published*, which references the published image sequence. This clip is also identified by a soft-imported icon in the lower-right corner, indicating that its media resides outside the framestore.
- For Simple Publish and Flatten Publish, each frame of the clip is published as part of a sequentially-numbered image sequence at the destination directory. The file names are identified as *<clip_name>#####.ext*, where ##### represents the image sequence number.
- For Complex Publish, all the media files are identified sequentially based on the position of the segment in the clip, and then sequentially based on the position of the image frame. The file names take the format: *<segment_name>_S###.#####.ext*, where S### represents the segment sequence number and ##### represents the image sequence number.

- For Flatten Publish, a new EDL file is published at the destination directory, named *<clip_name>.edl*. The EDL is a modified CMX 3600 EDL containing DLEDL flags. The EDL includes information for all the segments in a clip, including the head and tail information for dissolve and cut events and DLEDM comments.

If you publish a clip to the shared storage directory, other users can see the associated media. If other users in other applications change the published media, you will see the changes in the media of the soft-imported clip, without having to replace the clip. For example, if a user with access to the shared storage uses a paint program to modify the content of one of the files in the shared storage and replaces the file with the modifications, you will see these changes. However, if you change the clip in Flame, users outside of Flame will not be able to see these changes. You must re-publish the clip for users to see these changes.

NOTE If published media contains source files that are deleted or moved, the frames of the missing files will have a grey bar.

About the Publish Tool

The Publish tool allows you to share media with other applications and users without using space on the framestore. You access the Publish tool from the Clip Library Tools menu.

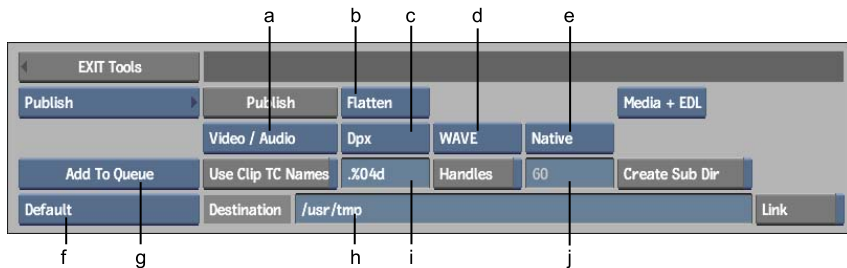

- (a) Media Type box (b) Publish Type box (c) File Type box (d) Audio File Format box
 (e) Audio Sample Width box (f) Destination Library box (g) Add To Queue box
 (h) Destination field (i) File Name Numbering field (j) Handles field

Publishing Options

Use the following publishing options to specify the attributes for the file that you publish.

Publish button Click to publish.

Media Type box Select the media types to publish. The Audio Only option is not available when Publish Type is set to Flatten.

File Type box Select the type of file that is exported.

Publish Type box Select the type of publishing. See [Types of Publishing](#) on page 292.

EDL button Enable to publish only an EDL file, or EDL and media. You can also choose to create only the EDL and omit media publishing. This allows you to regenerate the EDL file of a clip that has been published and later modified without re-publishing all the media. The EDL button is enabled only when Publish Type is set to Flatten.

Audio File Format box Click to select a format for an audio file to be published. The Audio File Format box is enabled when Media Type is set to Video/Audio or Audio Only.

Audio Sample Width box Click to select an audio sample width. 32-bit float is not available when the AIFF format is selected. The Audio Sample Width box is enabled when Media Type is set to Video/Audio or Audio Only.

Add To Queue box Select a method to publish in the background. See [Publishing in the Background](#) on page 298.

Select:	To:
Add to Queue	Add the job to the queue.
Add to Queue & Execute	Add the job to the queue and execute it automatically. If there are any jobs in progress, this job (and any others already added with the Add to Queue & Execute option) will be triggered upon the completion of its predecessor.

Destination Library box Select the library where the clips are published.

Destination field Enter the destination path of the file, which is usually the location of the shared storage. By default, the destination path is `/usr/tmp`.

Use Clip TC Names button Enable to sequentially number file names of frames based on the contents of the File Name Numbering field.

File Name Numbering field Enter the numbering scheme used to differentiate between the frames of a published clip in the destination directory when Use Clip TC Names is enabled. *%04d* appears as the default numbering scheme, where the 0 indicates that leading zeros will be appended to the file name for each frame, and the 4 indicates that four digits will be maintained. For example, if you have a 30-frame clip called *summer.sgi*, the published frames of the clip would be named `summer_s<#>.0001.sgi` to `summer_s<#>.0030.sgi`.

Handles button Enable to add head and tail frames to the published clip. The Handles button is enabled when Publish Type is set to Complex or Flatten.

Handles field Enter a value to determine the number of head and tail frames added to the published clip. The Handles field is active when the Handles button is enabled.

Link button Enable to link the published clips to the original file, located on the same filesystem. A link at the filesystem level is created to the media already located on the destination filesystem, which saves space because the media is not duplicated.

Link is not available when soft-importing a clip. The Link option is only relevant when using soft-imported clips in the Publish tool.

When you publish media from one filesystem to another, the media will be copied even if the Link option is enabled. In the case where you are publishing some media from the same filesystem and some from a different filesystem with the Link option enabled, any media that is on the same filesystem will be linked to the original media; any media that is on a different filesystem will be duplicated.

Create Sub Dir button Enable to create subdirectories that match the Autodesk Lustre format as follows: */basedir/clipname/tapename/resolution*. The Create Sub Dir button is enabled when Publish Type is set to Complex or Flatten.

Publishing a Clip Using the Publish Tool

When you publish a clip, the media is written to the destination on the shared storage and another clip is created that points to the newly created media on the shared storage. You can use the Publish tool to maintain soft edits. Three publishing options are available: Complex, Simple, and Flatten. When you publish soft-imported media, you can also decide whether or not to link directly to the source media located on the same filesystem. If you do not link

to the source media, a new copy of the files is created, which requires more space on the filesystem.

To publish a clip:

- 1 In the clip library, click Tools.
- 2 From the Tools box, select Publish.
The Publish controls appear.



- 3 In the clip library, select the clips that you want to publish.
- 4 From the Publish Type box, select the publish type.
The displayed options differ depending on the publish type selected. See [About the Publish Tool](#) on page 294.
- 5 Set any other Publish options using the corresponding controls.
- 6 In the Publish Destination field, enter the shared storage directory.
- 7 From the Destination Library box, select a destination library.

NOTE If your clips are not rendered and you press **Alt+Tab** (to toggle shells), after you click Publish Clip, corrupted frames may result.

- 8 Click Publish.

The clip is published to the selected library as follows:

- A new clip is published in the library, named *<clip name>_published*, which references a published image sequence.
- Each frame of the clip is published as part of a sequentially-numbered image sequence at the destination directory, where file names are *<clip name>.#####.ex*.

An icon indicating the file type appears in the lower-right corner of the clip. If the same file exists, you are asked if you want to overwrite it or abort the process.

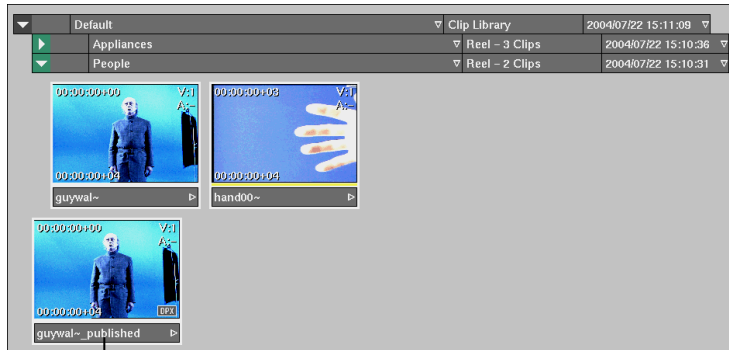

(a) Published clip

Images courtesy of Behavior Communications Inc.

NOTE A published clip does not have history. Accessing history for a newly published clip may cause a system crash.

Publishing in the Background

You can publish one or more image files in the background while you perform other tasks. Additionally, you can use the Stonifise tool to write media to the framestore in the background. To perform any of these tasks on several files at once, you can select them all and then process them as a batch. You can assign different clip options to each file that you add to the queue. You can also import and export files in the background simultaneously.

NOTE When importing or soft-importing files as a background process, you import them to a designated clip library, rather than to the desktop.

To publish in the background:

- 1 In the clip library, click Tools.
- 2 From the Tools box, select Publish.
The Publish controls appear.



- 3 In the clip library, select the clips that you want to publish.
- 4 From the Publish Type box, select the publish type.
The displayed options differ depending on the publish type selected. See [About the Publish Tool](#) on page 294.
- 5 Set any other Publish options using the corresponding controls.
- 6 In the Publish Destination field, enter the shared storage directory.
- 7 From the Destination Library box, select a destination library.

NOTE If your clips are not rendered and you press **Alt+Tab** (to toggle shells), after you click Publish Clip, corrupted frames may result.

- 8 From the Add to Queue box, select an option.

Select:	To:
Add to Queue	Add the job to the queue.
Add to Queue & Execute	Add the job to the queue and execute it automatically. If there are any jobs in progress, this job (and any others already added to the queue with the Add to Queue & Execute option) will be triggered upon the completion of its predecessor.

The progress of the export job is indicated in the queue.

Status:	Indicates:
Pending	Job has been added to the queue but not executed.
Queued	Job has been initialised.
Running	Job is being performed.
Done	Job has been executed.

- 9 If you are adding more publish jobs to the queue, you can continue using the file browser to locate other files that you want to publish.
- 10 To manage the Background Import/Export Queue, see [Managing the Background Import/Export Queue](#) on page 300.

Managing the Background Import/Export Queue

Use the Background Import/Export Queue to manage import, export, proxy generation, and publish jobs. You can also simultaneously generate proxies, and import, export, and publish any number of jobs.

To manage the Background Import/Export Queue:

- 1 In the Import or Export menu, swipe right and click BackgroundTasks (or press **F11**).

The Background Import/Export Queue appears.

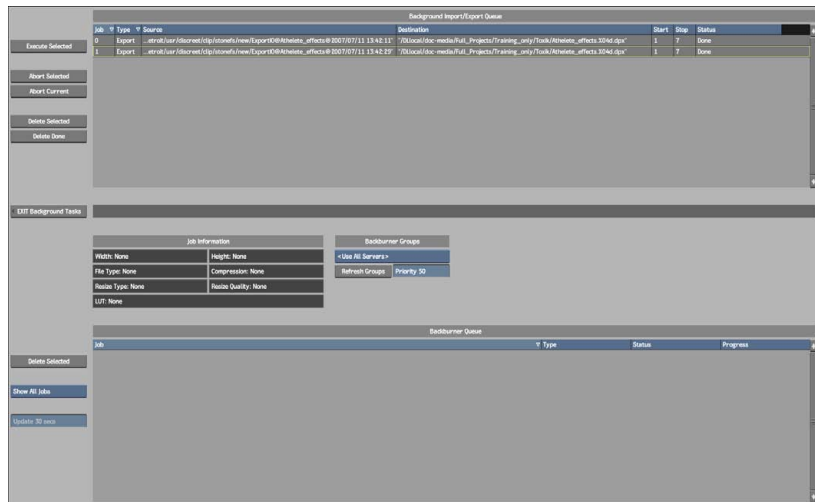

NOTE To change the order of the items in the Background Import/Export Queue, click the label of the column that you want to sort by.

- 2 Select a job in the queue to display the Job Information.

- 3 To remove jobs from the Background Import/Export Queue, do one of the following.

Click:	To remove:
Delete Selected	The currently highlighted job from the Import/Export Queue.
Delete Done	Completed jobs from the Import/Export Queue.

- 4 To abort jobs in the middle of processing, do one of the following.

Click:	To abort:
Abort Selected	The currently highlighted background job. The next selected job in the queue is executed.
Abort Current	All jobs currently being executed.

NOTE Any frames already processed are retained. For example, if the Status column reads 20 of 44 when you click Abort, you will have 20 of the 44 frames of the clip.

- 5 To begin processing jobs, select one or several jobs in the Background Import/Export Queue and click Execute Selected. To select several jobs, **Ctrl**-click or click-drag in the queue.

NOTE You can also click Execute Selected in the Import Image or Export Image menu.

- 6 Click EXIT Background Tasks (or press **F11** again) to go back to the Import Image or Export Image menu.

You can exit the Import Image or Export Image menu and work anywhere in Flame. To check the status of, or modify, your background jobs, press **F11** from any menu. The Background Status menu appears, showing the progress of the import or export job. Press **F11** again to return to the menu where you were working.

NOTE You can perform any command in the Background Status menu. However, to select items to import or export, you must access the menu from the Import Image or Export Image menu.

To import and export files simultaneously in the background:

- 1 Add jobs using the Import Image and Export Image menus.
- 2 Select the jobs you want to process.
- 3 Click Execute Selected.

All selected jobs in the Background Import/Export Queue are executed.

Processing Soft Effects and Batch FX

Processing is a convenient means of ensuring real-time playback when creating complex effects. If you are not achieving real-time playback, you can selectively process elements in the timeline (or the whole timeline) to restore it. Unlike committing, the effects remain editable after processing. If you have a Burn license, you can Burn clips containing soft effects, timewarps, and dissolves and process them on a remote rendering system.

You do not need to process effects prior to output from Batch using the Output node. Outputting from Batch renders video.

Processing renders the effect and writes new images to storage. When you play back the processed element, it is the new images that are presented in the Player. However, the information used to create the new image is retained by Flame; that is, the processing does not remove the “soft” part of the effect. The effect remains fully editable.

When working with proxies, you can save time by processing just the proxies rather than the full-resolution images. This can be helpful, for example, when working with a client in-house. You can refine an effect as desired using proxies and process the full-resolution images once you are both satisfied .

TIP When viewing the processed proxies, enable Proxy view in the Player options.

To process soft effects:

- 1 Select the elements with the soft effects that you want to process:
 - To select a single element, click it.
 - To select multiple elements, press the **Ctrl** key while clicking.
 - To select the entire timeline, press / on the numeric keypad, or click the element selection hot spot.

- 2 Select a processing option from the Process box. To trigger the selected option quickly, press the Process hot key (\).

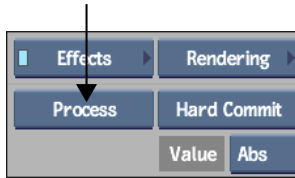

Select:	To:
Process	Process the selected elements. This is the standard option.
Force Process	Force a process on a soft effect that needs to be refreshed. Use this to force a process on a locked element, or when Flame fails to recognize that a processed clip is no longer valid. For example, if you change a layer in a complex vertical edit, you may need to force a process to update all the layers in the stack.
Process & Lock	Process an element and lock it. This prevents elements from being recognized by the system as no longer valid.
Force Proxy	Force the processing of a proxy on a soft effect that needs to be refreshed.
Proxy Process	Process proxies only, not the corresponding high-resolution images. An amber outline appears on the timeline segment to indicate the state of the processing.

If Burn is present, the following additional options are available.

Select:	To process:
Burn	Selected elements using Burn.
Force Burn	Selected elements, including locked effects, using Burn.
Burn Proxy	Proxies only for selected elements using Burn.
Force Burn Proxy	Proxies only for selected elements, including locked effects, using Burn.

The selected elements are processed. Once rendered, a solid black bar appears across the top of the element.

- 3 To abort a process, click an empty area of the user interface.
A dotted black bar appears across the unrendered portion of the element. When you process the element again, rendering begins at the unrendered portion. Frames already processed can be played in real time.

To process soft effects or Batch FX in the timeline:

- 1 Select the tracks or elements that you want to render.
- 2 From the TL Utility box, select a process option.



Select:	To:
Timeline Force Proxy	Force the processing of a proxy on Batch FX that need to be refreshed.
Timeline Process Proxy	Process proxies only, not the corresponding high-resolution images. An amber outline appears on the timeline segment to indicate the state of the processing.
Timeline Process & Lock	Process an element and lock it. This prevents elements from being recognized by the system as no longer valid.
Timeline Force Process	Force a process on Batch FX that need to be refreshed. Use this to force a process on a locked element, or when Flame fails to recognize that a processed clip is no longer valid. For example, if you change a layer in a complex vertical edit, you may need to force a process to update all the layers in the stack.
Timeline Process	Process the selected tracks or elements. This is the standard option.
Timeline Burn	Process selected tracks or elements using Burn on a remote rendering system.

The selected elements are rendered.

Processing Clips and Proxies

You can process clips in the clip library. If you have a Burn license, you can burn clips containing soft effects, timewarps, and dissolves from the clip library to a remote rendering system. You can also choose to only process proxies rather than full-resolution versions of the selected clips when rendering both locally and remotely with Burn.

You can unrender clips containing soft effects, timewarps, and dissolves. This is useful when you want to temporarily free up space on the framestore. For example, if you are working with clips from one project, you can unrender the clips from another project. Additionally, unrendering clips can be useful before archiving. The unrendered version of the clip requires less space so you can archive the media more quickly.

You can process Batch FX from the desktop without going back into Batch. Frames on the desktop containing unrendered Batch FX display the message “UNRENDERED FRAME Batch.” For more information, see [Force Rendering Clips](#) on page 966.

To process clips in the clip library:

- 1 In the clip library, select the clips that you want to process.
- 2 Click Tools to display the Tools menu, then choose Rendering Tools.
- 3 Select a rendering option.

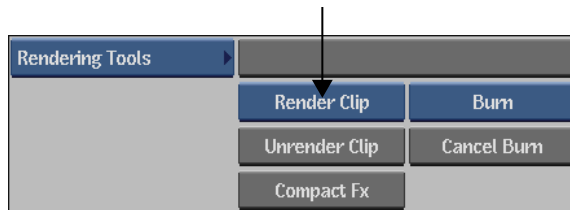

Select:	To:
Render Clip	Process the entire clips.
Proxy Render	Process only the proxies of the clips.

To unrender clips in the clip library:

- 1 In the clip library, select the clips that you want to unrender.

- 2 Click Tools to display the Tools menu, then choose Rendering Tools.
- 3 Click Unrender Clip.

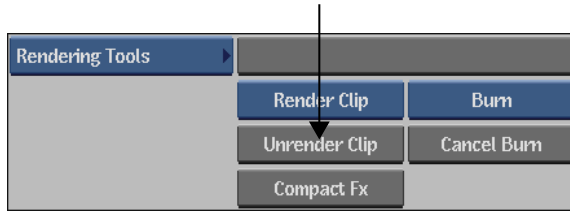

To burn clips or proxies in the clip library:

- 1 In the clip library, select the clips that you want to burn.
- 2 Click Tools to display the Tools menu, then choose Rendering Tools.
- 3 Select a Burn option and confirm the operation.

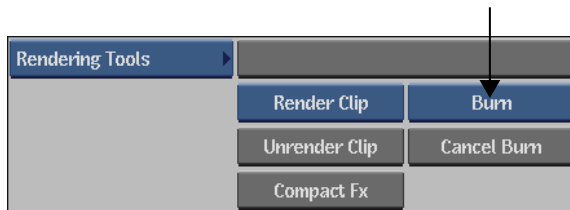

Select:	To:
Burn	Burn the entire clips.
Burn Proxy	Burn only the proxies of the clips.

The clip or proxy is processed with Burn. The rendered clip or proxy appears in the clip library when the processing is complete.

To process clips on the desktop:

- 1 From the Editing menu, click Force Render.
- 2 Select one of the following from the Force Render box.



Select:	To force render:
Desktop	All frames on the desktop.
Reel	All frames on a reel.
Clip	All frames in the clip.
Range	Selected frames in the clip.
Element	A single frame.

- 3 Select the reel, clip, frame, or starting and editing frames to render. The selection is rendered.

Processing in Modules

You can process or, if you have a Burn license, burn new renders in a number of modules. The resulting clips are placed on the Desktop. You can also process or burn multiple clips from the same module, and manage these tasks in the background.

To process or burn in a module:

- 1 In a module, once you are ready to process your clip, from the Process Options box, select either Process or Burn (if available).

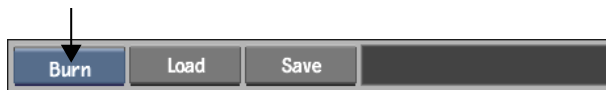

In some modules, the Process Options box contains more choices. For example, in Text, the Process Options box contains: Process, Matte, Both, Burn, Burn Matte, and Burn Both.

The Player button appears in the module.

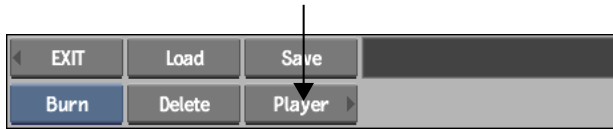

- 2 Click Player to access the module Player and see the result.
The module Player options appear.



(a) Clip List box

- 3 Use the Clip List box to monitor all the clips rendered from the same module.
Each entry in the list is preceded with a "Clip #" to distinguish between clips with the same name. A clip is displayed in the Player when it is selected in the list. The clip list gets flushed when you exit the module.
- 4 To manage the tasks being burned or processed, click Background Tasks. See [Managing the Background Import/Export Queue](#) on page 300.

Writing Media to the Framestore Using the Stonifise Tool

Writing media to the framestore is useful when you want to ensure that others cannot alter your work, or when you require real-time playback. This is especially useful for soft-imported media, which normally resides on an open, shared storage location.

You can write media to the framestore as a background process. See [Using the Stonifise Tool in the Background](#) on page 309.

To write media to the framestore:

- 1 In the clip library, select the clip that you want to write to the framestore.

- 2 Click Tools.
- 3 From the Tools box, select Stonifise.
The Stonifise options appear.

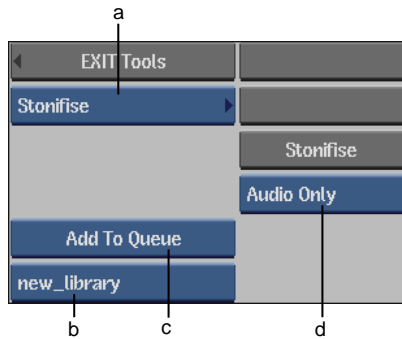

(a) Tools box (b) Destination Library box (c) Add To Queue box (d) Media Type box

- 4 From the Media Type box, select the option corresponding to your needs.

Select:	To:
Audio/Video	Write both audio and video media to the framestore.
Audio Only	Write only audio media to the framestore.
Video Only	Write only video media to the framestore.

- 5 Click Stonifise.

Copies of the selected clips are written to the framestore. The clips that you selected remain soft-imported. The original media is still available but is now a separate entity from the clip written to the framestore. If more than one instance of the same clip was soft-imported, only the media of the selected clips is written to the framestore.

Using the Stonifise Tool in the Background

You can write media to the framestore as a background process.

To write media to the framestore:

- 1 In the clip library, select the clip that you want to write to the framestore.
- 2 Click Tools.
- 3 From the Tools box, select Stonifise.
The Stonifise options appear.

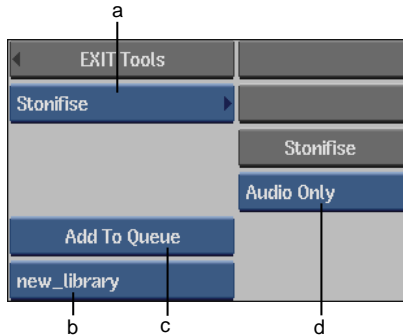

(a) Tools box (b) Destination Library box (c) Add To Queue box (d) Media Type box

- 4 From the Media Type box, select the option corresponding to your needs.

Select:	To:
Audio/Video	Write both audio and video media to the framestore.
Audio Only	Write only audio media to the framestore.
Video Only	Write only video media to the framestore.

- 5 From the Add to Queue box, select an option.

NOTE You can only write a single clip at a time to the framestore using the Stonifise tool in the background. To write multiple clips to the framestore in a single pass, you must perform the operation in the foreground.

Select:	To:
Add to Queue	Add the job to the queue.
Add to Queue & Execute	Add the job to the queue and execute it automatically. If there are any jobs in progress, this job (and any others

Select:	To:
	already added to the queue with the Add to Queue & Execute option) will be triggered upon the completion of its predecessor.
The progress of the export job is indicated in the queue.	
Status:	Indicates:
Pending	Job has been added to the queue but not executed.
Queued	Job has been initialised.
Running	Job is being performed.
Done	Job has been executed.

- To manage the Background Import/Export Queue, see [Managing the Background Import/Export Queue](#) on page 300.

Consolidating Clips

If you want to limit the number of head and tail frames on a clip, you can consolidate the audio and/or video on the clip. When several soft effects exist on a clip, the intermediate renders of these effects are kept. This procedure deletes media and frees up space on the framestore.

To consolidate clips, use the Consolidate controls in the Tools menu.

You can also use the Consolidate menu to delete intermediate and source history frames. See [Deleting Sources and Intermediates](#) on page 815.

To consolidate the audio and/or video on a clip:

- Select a single clip or hold **Ctrl** and select multiple clips in the clip library.
- Click Tools.
- From the Tools menu, click Consolidate.
The Consolidate controls appear.

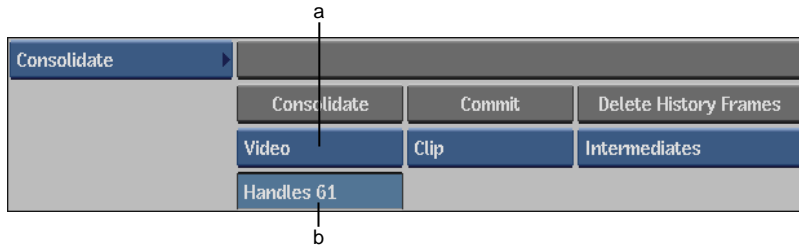

(a) Consolidate option box (b) Handles field

- 4 Select Audio, Video, or All Tracks from the Consolidate option box to determine which tracks will be affected by the consolidate operation.
- 5 In the Handles field, set the maximum number of head and tail frames that you want to retain after consolidating the clip.
- 6 Click Consolidate and confirm the operation.

Committing Soft Clips, History, or Audio

Use the Commit command to commit a soft clip, the history of the clip, or the audio of the clip. When you commit a soft clip, its soft properties are removed. Any history and audio of the clip is also committed. As well, head and tail frames are removed. If an element such as a timewarp has not been rendered, it will be rendered automatically before the commit. Commit a soft clip when you archive the clip or when you have completed the edit.

When you commit the history of the clip, you maintain the soft properties of the clip. Commit clip history when you no longer need to make tweaks to the modules in the clip history process tree.

Commit the audio when you do not want to affect the video of the clip but want to commit the audio tracks.

NOTE You cannot undo any commit operation.

To commit soft clips, history, or audio:

- 1 Click Tools.
- 2 From the Tools menu, click Consolidate.
- 3 Make a selection from the Commit Type box.

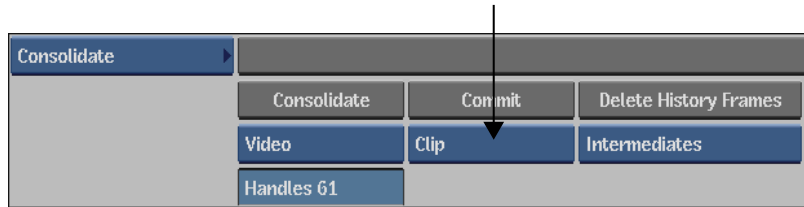

Select:	To:
Clip	Convert a soft clip to a source clip. If the clip has history or audio, these are also committed.
History	Commit the history of the clip but maintain the soft properties of the clip.
Audio	Commit the audio tracks.

- 4 Click Commit.
- 5 Click Confirm.

Compacting Clips

When several effects on the same segment of a clip are processed, all renders are kept, and the renders are stored on the framestore. You can remove the intermediate renders on a clip by compacting it. This procedure deletes media and frees up space on the framestore.

To compact a clip:

- 1 Select a single clip or hold **Ctrl** and select multiple clips in the clip library.
- 2 Click Tools.
- 3 From the Tools menu, click Rendering Tools.
- 4 From the Rendering Tools menu, click Compact Fx and confirm the operation.

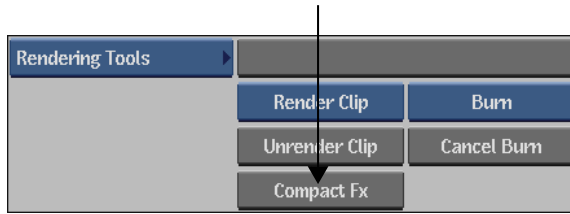

The intermediate processes are removed from the selected clips.

Part 4: Working with EDLs

Part 4 includes these chapters:

- [About EDL Files](#) on page 317
- [Importing EDL Files](#) on page 321
- [Creating and Editing EDL Files](#) on page 349
- [Capturing and Importing Media Using EDLs](#) on page 377
- [Exporting EDLs](#) on page 393
- [Timecode and Keycode](#) on page 403
- [Importing Final Cut Pro XML](#) on page 431
- [Importing Subtitle XML](#) on page 465
- [Importing AAF Files](#) on page 481
- [Importing and Exporting OMF Files](#) on page 499



Image courtesy of Duckling A-S

About EDL Files

13

Topics in this chapter:

- [About EDL Files](#) on page 317
- [Supported EDL Formats](#) on page 318
- [About DLEDL Files](#) on page 319
- [Working with EDLs](#) on page 319

About EDL Files

An EDL (Edit Decision List) file is a digital list of commands used to describe a series of film or video edits. It consists of an ordered list of reel, keycode, and timecode data, which represents the original location (usually video tapes or sequences of images stored on disk) of each media clip used in the edit. These media clips can later be easily obtained in order to conform the final cut. EDLs are the primary method of transferring information about an edit project between offline and online editing systems.

The most primitive EDL formats are telecine log files. Telecine log files typically describe the most basic edit decisions, which contain only tape name, clip name, source timecode, keycode, and whether 2:3 pulldown was used.

Standard EDL formats, such as CMX3600, support basic functions, such as cuts, dissolves, SMPTE wipes, speed variations (including freeze frames), and direction

changes (Forward/Reverse). EDL comments, clip names, and audio patching comments are also supported.

OMF, AAF, and FCP XML file formats are more modern, enhanced formats of EDLs, supporting multiple layers of video and audio, as well as an expanded set of transitions and effects. Some may include embedded audio.

Collectively, all these formats are known as File Interchange® Formats, but they are still commonly referred to as EDLs.

Supported EDL Formats

Flame supports the Telecine Log, Standard EDL, and Enhanced EDL formats as follows:

Telecine Log Formats

The following telecine log file types are supported by Flame:

- FLX (Flex)
- ATN (AATON)
- TLC (Telecine Log Converter)
- ALE (Avid® Log Exchange)

NOTE ALE files also support the basic functions of other EDL types.

Standard EDL Formats

The following Standard EDL formats are supported by Flame:

- CMX 340
- CMX 3600
- CMX OMNI (ASCII version)
- GVG 4
- GVG 4 Plus (v4.1 or higher)
- SONY 900
- EDM (edit)
- SONY™ 910
- SONY 5000
- SONY 9000
- SONY 9000 Plus (v2.21 or higher)
- SONY 9100
- ALE (Avid® Log Exchange)

NOTE It is recommended that you use EDLs in the CMX 3600 format.

Enhanced EDL Formats

The following enhanced EDL formats are supported by Flame:

- Open Media Framework® (OMF) Interchange® files. See [Importing and Exporting OMF Files](#) on page 499.
- Advanced Authoring Format (AAF) files. See [Importing AAF Files](#) on page 481.
- Final Cut Pro® (FCP) XML files. See [Importing Final Cut Pro XML](#) on page 431.
- Subtitle XML. See [Importing Subtitle XML](#) on page 465.

About DLEDL Files

A DLEDL is an EDL file based on the CMX 3600 format supported by most digital nonlinear editing systems. DLEDLS are unique to Autodesk Visual Effects and Finishing applications and contain extra comments that are interpreted by Flame.

Using DLEDLs in your post-production workflow allows you to automate the import of media files (video and audio) residing in different locations. Instead of performing media import for each file separately, you can use a DLEDL to import all media files in a single operation, which allows you to significantly save processing time. See [Creating and Editing EDL Files](#) on page 349.

Working with EDLs

Typically, when working on media projects, you receive offline EDLs from which you capture, or import, and then assemble your clips for the finishing process. You may also edit an EDL and export it as another format.

Importing EDLs

You can import EDLs in any standard format, including telecine logs, standard EDLs, or enhanced EDLs, into Flame. In many cases, the EDLs point to material

that matches your project's default resolution. However, because Flame provides a mixed resolution environment, you can also use EDL tools to capture and assemble clips of any resolution within the same project. You can also use EDL conversion tools to convert EDLs from one video standard to another. For example, you can convert an offline NTSC EDL to an HD 59.97 format and then capture the full-resolution sources for finishing. See [Importing EDL Files](#) on page 321.

Editing EDLs

You can import EDLs in any standard format and edit them while dynamically seeing your changes. You may include DLEDL flags in the event comments that reference the location and name of file-based media for multiple file import. See [Creating and Editing EDL Files](#) on page 349.

Capturing and Importing Media Using EDLs

You can use an EDL to reconstruct a work session created in an offline editing system. You can use an EDL to capture image or audio media from a VTR into Flame, or to import (or soft-import) media files from a standard filesystem into Flame. See [Capturing and Importing Media Using EDLs](#) on page 377.

Exporting EDLs

You can also export EDL-based projects in cases where you need to perform some processing in another application, or for the purpose of archiving. In the process of outputting an EDL, you actually output the media used to build a clip to the clip library or to a VTR. This is useful for quickly dumping source clips onto a tape. You can also output an EDL in order to conform a program on another system, for example, to perform the final colour grading. See [Exporting EDLs](#) on page 393.

Timecode and Keycode

An integral component of EDLs is timecode and keycode. These are the identification markers by which your media is referenced in an EDL. Timecode and keycode can be imported with the material, assigned, changed, burned-in, or removed. See [Timecode and Keycode](#) on page 403.

Importing EDL Files

I 4

Topics in this chapter:

- [About Importing EDL Files](#) on page 321
- [About the Import EDL Menu](#) on page 322
- [About the Load EDL Menu](#) on page 334
- [Importing EDLs](#) on page 335
- [Importing EDLs at Non-Native Frame Rates](#) on page 337
- [Importing EDLs with Varicam Information](#) on page 338
- [Converting EDLs](#) on page 339
- [Loading File-based EDLs](#) on page 340
- [Searching EDLs](#) on page 346
- [Closing EDLs](#) on page 347

About Importing EDL Files

Use an EDL to reconstruct a work session created in an offline editing system or to import image sequences from a standard filesystem. Typically, when recreating a project from an interchange file such as an EDL (referred to as conforming an EDL), you import the file, capture the material or import the referenced files, and then assemble the captured or imported material into a clip on a destination library reel.

This chapter covers the import of standard EDLs and telecine log files. Other file interchange formats are covered as follows:

- Final Cut Pro® (FCP) XML files. See [Importing Final Cut Pro XML](#) on page 431.
- Advanced Authoring Format (AAF) files. See [Importing AAF Files](#) on page 481.
- Open Media Framework® (OMF) Interchange files. See [Importing and Exporting OMF Files](#) on page 499.
- Subtitle XML. See [Importing Subtitle XML](#) on page 465.

About the Import EDL Menu

Use the Import EDL menu to create, import, edit, auto-capture, assemble, and save EDLs.

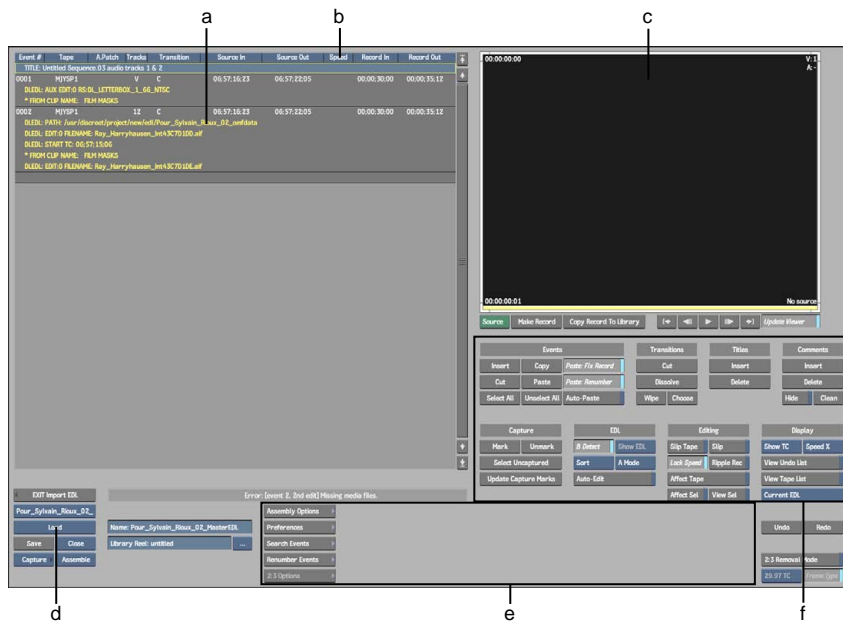

(a) EDL work area (b) Work area column headers (c) EDL Player (d) EDL editing tools (e) Load button (f) Import EDL menus

The EDL work area is divided into 12 columns.

Event # The event number, followed by a capture indicator.

Tape The name of the tape containing the source clip.

A. Patch The Audio Patch information.

Tracks The track for the edit (shown as a combination of: V, 1, 2, 3, 4, 5, 6, 7, 8).

Transition The type of transition between the clips: C for cuts, D <duration> for dissolves, and W <wipe code> <duration> for SMPTE wipes.

Source In The starting timecode of the element in the source clip.

Source Out The ending timecode of the element in the source clip. (**Ctrl-click** the heading to view Source duration.)

Keycode In The starting keycode of the element in the source clip.

Keycode Out The ending keycode of the element in the source clip.

Speed The speed at which the source clip is timewarped in the edit. The value is preceded by a negative sign if the effect is a reverse. The column is blank if the speed value is 100% (no timewarp).

Record In The starting timecode of the element in the result clip.

Record Out The ending timecode of the element in the result clip. (**Ctrl-click** the heading to view Record duration.)

NOTE The EDL file may contain more than one page of entries. To see all the events in the EDL, use the scroll bar to scroll up or down the list.

Operations Group

The Operations group contains the commands that allow you to import an EDL.



(a) File Name field

Assembly Options Menu

The Assembly Options menu contains options that you can set that affect EDL assembly.

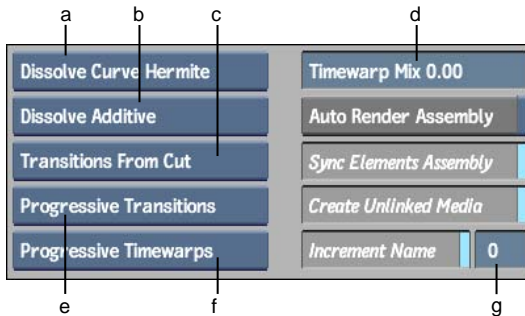

(a) Dissolve Curves box (b) Dissolve Type box (c) Transitions Alignment box
 (d) Timewarp Mix field (e) Transition Render Option box (f) Timewarp Render Option box (g) Increment field

Dissolve Curves box Select the type of interpolation to use for all dissolves.

Select:	To:
Dissolve Curves Linear	Create dissolves with linear interpolation curves.
Dissolve Curves Hermite	Create dissolves with hermite interpolation curves.

Dissolve Type box Select a rendering option for dissolves during EDL assembly.

Select:	To:
Dissolve Additive	Render dissolves as additive.
Dissolve Non Additive	Render dissolves as non additive.
Dissolve Inv Non Additive	Render dissolves as inverse non additive.

Transitions Alignment box Select an option for the placement of transitions in assembled EDLs.

Select:	To:
Transitions From Cut	Align transitions after the cut.
Transitions Centred	Centre transitions on the cut.
Transitions Up To Cut	Align transitions before the cut.

Transition Render Option box Select the rendering mode for transitions in assembled EDLs.

Select:	To:
Interlaced Transitions	Override the Preferences settings and render transitions in Interlaced mode.
Progressive Transitions	Override the Preferences settings and render transitions in Progressive mode.

Timewarp Render Option box Select an option for the rendering mode for timewarps in assembled EDL.

Select:	To:
Progressive TW	Render timewarps in Progressive mode.
Interlaced TW	Render timewarps in Interlaced mode.

Timewarp Mix field Enter the mix value for assembled timewarps. You can enter any value from 0.00 to 1000.00.

Auto Render Assembly button Enable to render transitions and timewarps when you assemble the final clip.

Sync Elements Assembly button Enable to automatically create Edit Sync groups for video and audio tracks that share the same timecode. See [Creating Edit Sync Groups for Multiple Video Tracks](#) on page 994.

Create Unlinked Media button Enable to assemble an EDL, even if you do not have all the sources and, later, use the Recapture/Relink media feature to bring the missing media into your work-in-progress timeline clip.

When you disable this option, you get virtual sources with no indication of source timecode and tape name for the events when no recapture media exists for an event.

Increment Name button Enable to increment the assembled clip name (when assembling the same clip multiple times).

Increment field Enter a number by which the name is incremented. Active only when the Increment Name button is enabled.

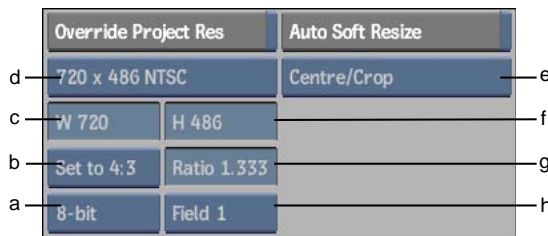

(a) Frame Depth box (b) Aspect Ratio Presets box (c) Frame Width field (d) Resolution Presets box (e) Fit Method box (f) Frame Height field (g) Aspect Ratio field (h) Scan Mode box

Override Project Resolution button Enable to assemble pre-captured material of a different resolution than your project's default resolution. Additional controls become active that you use to specify the resolution options for assembly.

During assembly, the system searches the specified library reel for matching media. For media to match an event during EDL assembly, all the specified parameters must be the same (including frame rate, resolution, bit depth, and so on). When a match occurs for an event, the event is marked as captured.

By default, Override Project Resolution is disabled and the project's default resolution is used when matching EDL events to pre-captured media.

NOTE If an EDL refers to a clip that has the same tape name and timecode but is of a different resolution than the default resolution or that of the first matched event, the clip will not be marked as captured. For example, if you are assembling an NTSC EDL and the EDL refers to a captured HD clip with the same tape name and timecode, the HD clip will not be marked as captured.

Resolution Presets box Select one of many standard resolutions, as well as a Custom option that you can use to specify non-standard resolutions.

Auto Soft Resize button Enable to apply a soft resize when assembling any clip that was captured at a resolution that differs from the native project resolution. Options become active that allow you to specify how the soft resize should be applied.

Fit Method box Select a fit method option to be applied to the imported clip.

Select:	To:
Centre/Crop	Fit the source image, centred, over the destination frame. If the source is larger than the destination, it is cropped. If the source is smaller than the destination, it is surrounded by a black border.
Crop Edges	Fit one edge of the source into the destination frame without stretching or squashing the frame. Excess parts of the source frame after resizing are cropped. If the source—after the one edge is resized—is wider than the destination, its overhanging left and right edges are cropped. If the source is taller than the destination, the upper and lower edges are cropped.
Fill	Fit the source, width and height, into the destination frame. If the source and destination frames do not have the same aspect ratio, the image can become distorted.
Letterbox	Fit the source to the destination frame without squashing or stretching it, and without cropping the source. If the source is wider than the destination, black bars fill the top and bottom of the destination frame. If the source is narrower than the destination, black bars fill the right and left sides of the frame. In all cases, the entire source frame is contained within the destination frame.

Frame Width field Displays the frame width of the selected resolution preset. If Resolution Presets is set to Custom then this field is active, allowing you to enter the frame width value that you want to use.

Aspect Ratio Presets box Select a standard frame aspect ratio. Select the Set to w:h option to set the clip to use square pixels. Select Custom to define a custom frame aspect ratio in the Aspect Ratio field.

Frame Depth box Select from one of five frame depth options: 8-bit, 10-bit, 12-bit, 12-bit u, or 16-bit fp.

Frame Height field Displays the frame height of the selected resolution preset. If Resolution Presets is set to Custom then this field is active, allowing you to enter the frame height value that you want to use.

Aspect Ratio field Displays the aspect ratio of the imported clip. When Aspect Ratio Presets is set to Custom, this field becomes active so that you can enter a custom frame aspect ratio.

Scan Mode box Select an option to determine the order in which the fields of interlaced material are scanned.

Select:	To:
Progressive	Scan a frame-based clip with no interlacing.
Field 1	Scan Field 1 first, followed by Field 2.
Field 2	Scan Field 2 first, followed by Field 1.

Preferences Menu

Use the options in the EDL Preferences menu to specify your EDL preferences.

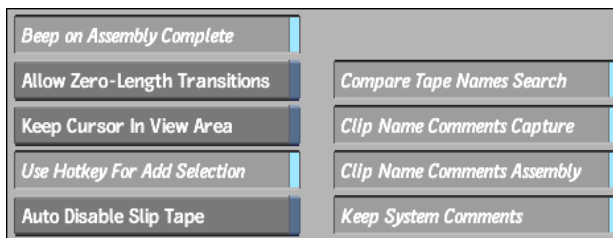

Beep on Assembly Complete button Enable to hear an audible tone when the EDL is assembled.

Allow Zero-Length Transitions button Enable to allow zero-length wipes and dissolves. If this option is disabled and you change a transition duration to zero, the transition automatically becomes a cut.

Keep Cursor In View Area button Enable to keep the cursor from leaving the window when you scroll an EDL. When you scroll an EDL, the cursor will stop at the first or last event on the EDL page.

Compare Tape Names Search button Disable to ignore tape names during assembly.

Clip Name Comments Capture button If your events contain clip names in their comments, enable this option to use those names during capture. If this option is disabled, the event number is used as the captured shot's name.

Use Hotkey For Add Selection button Use to change the functionality of selecting events. When this option is disabled, you add to your selection range by clicking the events. When this option is enabled, you must hold the **Ctrl** key or the pen button while clicking events to add them to your selection range.

Auto Disable Slip Tape button By default, the Slip Tape option remains enabled after you slip sources. Enable this option to disable the Slip Tape option automatically after you slip sources.

Clip Name Comments Assembly button If your events contain clip names in their comments, enable this option to use those names during assembly. If this option is disabled, the EDL title is used as the assembled clip's name.

Keep System Comments button Use the Keep System Comments option to protect system comments. When enabled, you can only delete user comments.

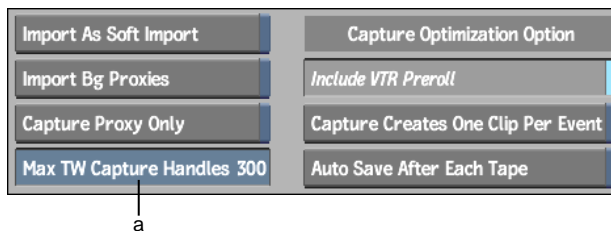

(a) Max TW Capture Handles 300 field

Import As Soft Import button Enable to soft-import files with a file-based EDL that are located on a standard filesystem. If you disable this option, the files are hard-imported.

Import Background Proxies button Enable to allow proxies to be generated in the background.

Include VTR Preroll button Enable to capture the events in one pass and store them as individual clips in the clip library. By default, if events in an

EDL are separated by a shorter duration than the VTR preroll and more than 10 frames, they are captured in a single pass.

Capture Proxy Only button Use this option in HD projects to auto-capture proxies only when conforming an EDL. This option does not appear in SD projects.

Max TW Capture Handles field You can set the maximum number of handles to be captured for source clips that are part of timewarped events. On timewarped events, the capture handles value is equal to the capture handles value multiplied by the speed of the timewarp. For example, for an EDL event with an increased speed of 500% (in NTSC), if the capture handles are set to 30 frames, 150 frames are captured as handles (30 frames multiplied by 5).

Standard handles may not be enough in the case of high-speed timewarps.

Capture Creates One Clip Per Event button Enable to create a clip in the clip library for every event in the EDL. When disabled, a single clip is created in the library for each group of events captured during the same pass. You can assemble the montage regardless of which option you chose to store EDL events in the clip library.

To reduce the size of clip libraries, you should disable this feature. However, if you need to reference back to individual shots, they may be easier to find if you enable the option and generate a clip for every event.

Auto Save After Each Tape button When this option is enabled, the system performs an AutoSave between each tape when auto-capturing.

Search Events Menu

Use the Search Events menu to search entries for text or timecode in an EDL. When you search the EDL, you need to specify the item you want to search, the filter type you want to use, and the criteria for which you want to search.

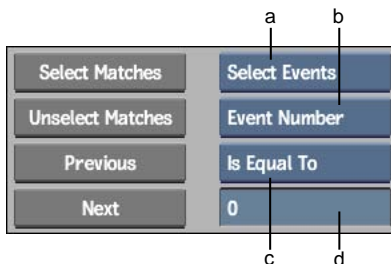

(a) Select Item box (b) Search Item box (c) Filter Type box (d) Search Criteria field

Select Matches button Highlight all items that match the search criteria.

Unselect Matches button Remove the highlight from all items that match the search criteria.

Select Item box Select the option that you want to search for.

Select:	To highlight:
Select Events	All events that match the search criteria.
Select Edits	All edits that match the search criteria.

Search Item box Specify the item that you want to search for in the EDL.

Select:	To search for:
Event Number	Event numbers.
Tape	Tape names.
Transition Length	A specific transition duration.
Source In	A source in timecode.
Source Out	A source out timecode.
Speed	A specific timewarp speed.
Record In	A record in timecode.
Record Out	A record out timecode.
Comment	A comment or text within a comment.
Track	A track.

Previous button Move the cursor to the previous item that matches the search criteria.

Next button Move the cursor to the next item that matches the search criteria.

Filter Type box Specify the filter type. The filter type will differ depending on the item you are searching. For numerical searches, select one of the following options from the Filter Type box.

Select:	To find:
Is Equal to	All event numbers that match your search criteria.
Is Not Equal to	All event numbers that do not match your search criteria.
Is Less Than	All event numbers that are less than your search criteria.
Is Greater Than	All event numbers that are greater than your search criteria.

For alphabetical searches, select one of the following options from the Filter Type box.

Select:	To search:
Matches	For all tapes that match your search criteria.
Does Not Match	For all tapes that do not match your search criteria.
Contains	For all tapes that contain your search criteria.
Does Not Contain	For all tapes that do not contain your search criteria.
Is Less Than	For all tapes lexicographically less than your search criteria.
Is Greater Than	For all tapes lexicographically greater than your search criteria.

Alphabetical searches are performed on Tape and Comment items by default. To perform a numeric search on these items, enable Treat As Numeric. To match results by case, enable Case Sensitive.

Search Criteria field Enter the search criteria.

Renumber Events Menu

Use the options in the Renumber Events menu to specify the value by which events are renumbered.

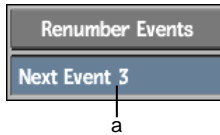

(a) Next Event field

Renumber Events button Renumbers the selected events according to the value specified in the Next Event field.

Next Event field Enter a value for the next event.

2:3 Pulldown Options Menu

Use the 2:3 Pulldown Options menu to set the parameters for 2:3 pulldown insertion upon import.

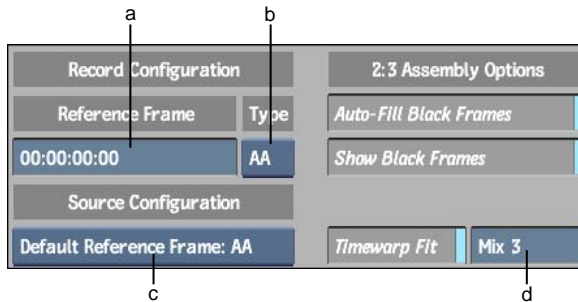

(a) Reference Frame field (b) Reference Frame Type box (c) Default Reference Frame box (d) Mix field

Reference Frame field Enter the timecode for the reference frame. This is only required for clips stored as files, and not for material on tapes.

Reference Frame Type box Set the reference frame type: AA or BB, corresponding to the timecode value entered in the Reference Frame field.

Auto-Fill Black Frames button Enable to fill black frames with the last frame of the outgoing event. By default, gaps occurring between EDL events are filled with black frames.

Default Reference Frame box Select AA or BB.

Show Black Frames button Enable to highlight the places in the currently loaded EDLs where gaps of black frames occur.

Timewarp Fit button Enable to automatically apply a timewarp to material on tapes referenced by EDLs where 2:3 pulldown removal was disabled (for example, when a tape contains native 30 fps interlaced video material), so that it can be easily integrated with 24 fps material.

Mix field Enter the number of frames to ensure that match frames on timewarped elements are maintained. This field is active when Timewarp Fit is enabled.

About the Load EDL Menu

Use the Load EDL menu to set a variety of options when loading EDLs.

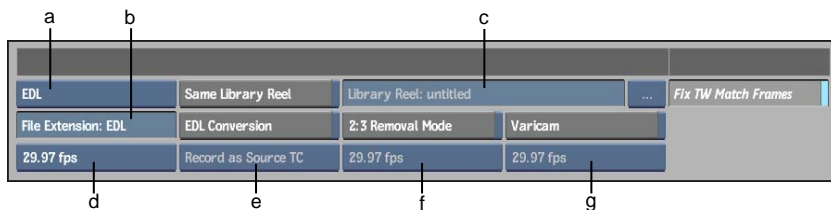

(a) EDL Type box (b) File Extension field (c) File Name field (d) EDL Frame Rate box (e) Conversion option box (f) Frame Code Mode box (g) Varicam Frame Rate box

Exit Load EDL button Exits the Load EDL menu.

EDL Type box Select an EDL type to load. Available options are: ALE, FLX, ATN, TLC, EDM, R23, ETL, and OMF.

File Extension field Displays the file extension for the associated file type. Click to enter a new one.

Same Library Reel button Enable to load a series of EDLs, capture the EDLs, and assemble them on the same reel in the clip library. When you are capturing an EDL and you enable Multi-assemble, only the EDLs that are set to the same library reel are captured.

EDL Conversion button Enable to convert the EDL to another frame rate. See [Converting EDLs](#) on page 339.

File Name field Enter a filename.

2:3 Removal Mode button Enable to remove pulldown when loading the EDL. See [2:3 Pulldown](#) on page 703.

Varicam button Enable if the EDL is used to capture material shot with Varicam.

Fix TW Match Frames button Enable to fix match frame errors. When you import an EDL that contains dissolves or timewarps, a match frame error may occur. This can cause an unwanted cut at the point where the timewarp begins in your EDL. Match frame errors occur when the in point of the second edit in a dissolve is not the same timecode as the out point of the previous shot. This feature is enabled by default.

EDL Frame Rate box Displays the framerate of the current EDL. Click to select another one.

Conversion option box Select the option that corresponds to the type of conversion that you want to apply to the EDL. The conversion scripts that appear in this list depend on the frame rate of the EDL you are loading.

Frame Code Mode box Select the option (29.97 fps or 30 fps) that corresponds to the EDLs that you are loading. If you are loading multiple EDLs, the same Frame Code Mode is used for all of them.

Varicam Frame Rate box Select the Varicam frame rate.

Importing EDLs

You can import as many EDLs as you want simultaneously. However, the EDL module displays only one EDL at a time. When you import an EDL, you have the option of converting the EDL to another frame rate, removing pulldown, and fixing timewarp errors. You can also import EDLs that reference material shot with Varicam. Since you can work in multiple resolutions in Flame, you also have the option of importing an EDL at a non-native project frame rate.

In addition to EDLs, you can import ALE, FLX, ATN, and TLC files into the EDL module.

Use DLEDLs where you need to import multiple media files in a single pass. Using DLEDLs in your post-production workflow allows you to automate the import of media files (video and audio) residing in different locations. Instead of performing media import for each file separately, you can create a DLEDL and import all media files in a single operation, which allows you to significantly save processing time.

To import an EDL:

- 1 In the clip library, from the Interchange Format box, select EDL.

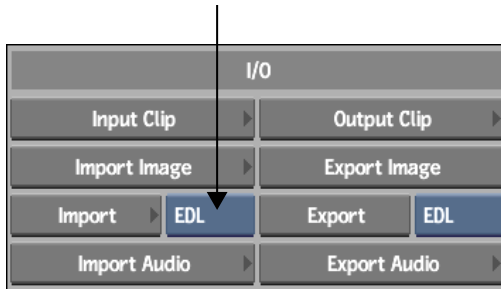

- 2 Click Import.
- 3 In the Import EDL menu, click Load.
The file browser and the Load EDL menu appear.
- 4 Select the type of file that you want to import from the EDL Type box.

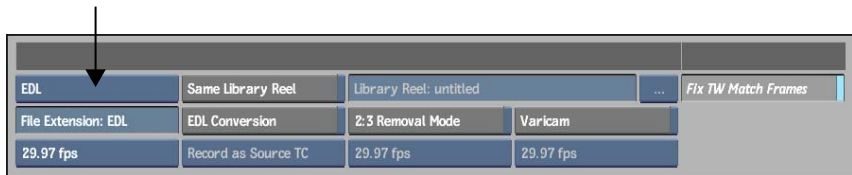

Files of the selected type appear in the file browser.

- 5 Set any options, such as Same Library Reel, EDL Conversion, 2:3 Removal Mode, Fix TW Match Frames, or Varicam. See [About the Import EDL Menu](#) on page 322.
- 6 From the file browser, select the file to load.

TIP To load multiple EDLs, hold **Ctrl** and select the EDLs.

- 7 Click Load.

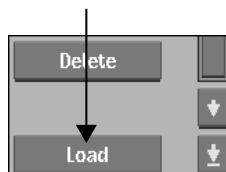

The Import EDL menu reappears.

- To toggle the display between timecode and keycode, click the Timecode/Keycode button. Keycode will only be displayed if it is present and correctly corresponds to the timecode for events. If there is no keycode data for a particular event, timecode is displayed.

Event #	Tape	A.Patch	Tracks	Transition	Keycode In	Keycode Out	Speed	Record In	Record Out
TITLE: 001									
0001	002		V	C	03:59:59:14	03:59:59:29		00:00:00:00	00:00:00:15
0002	002		V	C	KK248181 6659+03	KK248181 6660+14		00:00:00:15	00:00:01:25
0003	002		V	C	KK248181 6660+14	KK248181 6676+09		00:00:01:25	00:00:15:25
0004	002		V	C	FN723405 8172+12	FN723405 8193+08		00:00:15:25	00:00:34:10

- (a) Keycode for events (b) Keycode In column (c) Keycode Out column
 (d) Timecode for event with missing keycode

- Switch between the currently open EDLs by selecting the EDL that you want to view from the EDL box.

Importing EDLs at Non-Native Frame Rates

You can load any EDL into your project, regardless of the frame rate of the imported EDL. Once the EDL is loaded, you can assemble it into a clip. For the system to recognize the media from a non-native frame rate EDL and mark it as captured, the **Override Project Resolution** button must be enabled before assembling. See [Assembly Options Menu](#) on page 324.

To import a non-native frame rate EDL into a project:

- In the Editing menu, from the Interchange Format box, select EDL, then click Import.
- In the Import EDL menu, click Load.
- In the EDL Load menu, select the frame rate of the EDL you are importing.

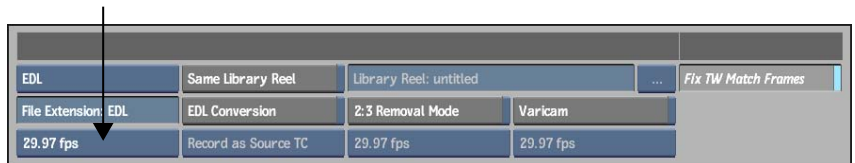

- In the file browser, select the EDLs that you want to load.
- Click Load.

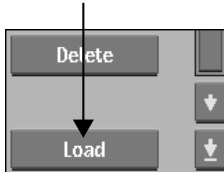

Importing EDLs with Varicam Information

Varicam is a type of camera that can record material to tape at different frame rates, even though the tape always runs at 60p. Frames are recorded to tape in such a way that Flame can decode them into a supported frame rate on capture.

Flame removes the redundant frames so that the frame rate of the captured clip corresponds to the frame rate of the project. You can monitor the process using the VTR Status display. The Current Frame Rate field is updated depending on the frame rate of the captured material. Upon loading, the EDL will be converted to the correct Timecode.

You can import EDLs that reference material shot on Varicam, but note the following:

- You should use a Varicam project template when importing Varicam material so that the imported clips will have the proper frame code mode and timing. To enable Varicam project templates, the corresponding 1280X720p VideoPreviewDevice keyword must be defined in the *init.cfg* file. See the *Autodesk Visual Effects and Finishing Configuration File Reference Guide*.
- EDLs that reference media shot on Varicam at unsupported frame rates (referred to as “off speed”) cannot be properly recaptured. Instead, you can use the Panasonic® Frame Rate Converter to convert media to a supported frame rate before you perform the offline.
- You cannot use Varicam in conjunction with 2:3 Removal Mode or EDL Conversion.

You can import EDLs, FCP XML, and AAF files that reference tape-based media shot on Varicam.

To load an EDL with Varicam media:

- 1 From the Import EDL menu, click Load.

The Load EDL menu appears.

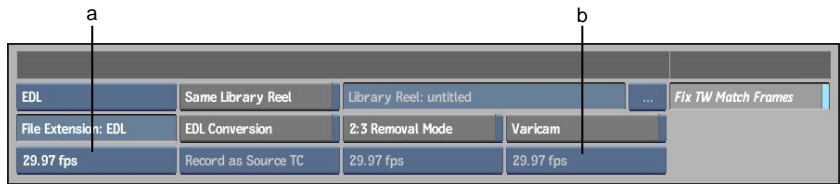

(a) EDL Frame Rate box (b) Varicam Frame Rate box

- 2 Select an EDL file with Varicam information.
- 3 Enable the Varicam button.
The EDL Conversion and 2:3 Removal Mode buttons are disabled.
- 4 Select the Varicam frame rate.
The Varicam Frame Rate box only includes the frame rates that can be used: 23.976, 24, 29.97, 30, 59.94, and 60 fps.
- 5 Select the EDL frame rate.
When Varicam is enabled, the EDL Frame Rate box only includes the frame rates that can be used: 23.976, 24, 29.97, 30, 59.94, and 60 fps.
- 6 Click Load.
The EDL with Varicam media is loaded into the Import EDL menu.
- 7 From the Show Timecode box, select Show VC to display the Varicam timecode in the EDL work area.
The timecode of events on the Varicam tapes is displayed in the EDL work area. This timecode is set at 30 fps, even though Varicam tapes contain 60 fps progressive media.

Converting EDLs

Use the EDL conversion utility to convert an EDL from one frame rate to an EDL of another frame rate. The available conversion scripts depend on the frame rate of the original EDL.

To convert the EDL to the correct format when loaded:

- 1 If necessary, disable the Varicam button.

- 2 In the Load EDL menu, select an EDL, and then enable EDL Conversion.
- 3 In the Conversion option box, select the option that corresponds to the type of conversion you want to apply to the EDL. The conversion scripts that appear in this list depend on the frame rate of the EDL you are loading.

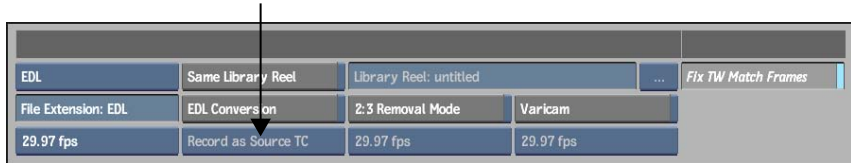

- 4 Click Load to convert and load the EDL.

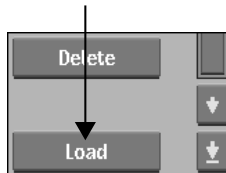

Depending on the option you select, all timecodes in the EDL are recalculated, and a suffix (such as `_60p` or `_24p`) is added to the EDL in the EDL list.

You can also use the EDL Conversion tool to use the Record Timecode as Source Timecode and to capture one tape for the whole show. The original tape names will get converted to comments that you could filter on the Desktop to apply soft effects on.

Loading File-based EDLs

A file-based EDL is a type of log file that you use to import (or soft import) image sequences from a standard filesystem. File-based EDLs can include image files and audio files. Telecine logs can only include image files.

All EDLs contain event numbers, cuts, and timecode. A file-based EDL differs from a standard EDL in that it contains comments that point to the location of media files. Generally, you do not assemble a file-based EDL into a record timeline clip. An exception is FCP XML files created during offline sessions. See [Importing Final Cut Pro XML](#) on page 436.

You load a file-based EDL in the same way that you load a standard EDL.

You can use the EDL module to import telecine logs. When you load a telecine log from the EDL module, only the following information is imported:

- Tape name
- Clip name
- Source timecode
- Keycode
- 2:3 pulldown removal information (whether there is 2:3 pulldown, the reference frame timecode, the reference type, and the drop frame reference timecode)

A file-based EDL correlates the timecode from tapes to keycode from film reels for one or more contiguous clips. The timecode reflects where on the tape clips were recorded during a telecine or offline edit session. The keycode indicates the source reel and frames of film where the clips originated from.

As well, using these files, you can recapture material from tape with pulldown removal because the pulldown phase is indicated for each sequence.

The other elements contained in the file, such as audio information, are disregarded.

Loading ALE Files

You can load Avid® Log Exchange (ALE) files into the EDL module. The source information from the ALE file is extracted to create the EDL.

ALE files do not reflect a full editing session because they do not contain record timecodes. When the ALE file is imported into the EDL module, it is assigned record timecodes automatically, starting with the default start record timecode specified in the Preferences menu.

NOTE If you are working in NTSC, the record timecode is added in drop-frame mode.

ALE files must contain the following three sections:

- Heading
- Column
- Data

The Heading section contains information such as the video format and tape name. The Column section contains the heading names for the data, such as start timecode, end timecode, start and end keycode, and track information. The Data section contains the data for the file, such as timecode, name, and track information.

Each column of data in the ALE file must be separated by a tab. The Column headings can appear in any order as long as the column data appears below the correct heading.

To be converted to an EDL file, the ALE file must have the following data.

Entry	Required Syntax
Heading	VIDEO_FORMAT <format> where <format> is NTSC or PAL
Column	Start
Column	End

NOTE If any of the above syntax is missing, it is not a valid ALE file and will be rejected.

The following optional data will be recognized and used if present.

Entry	Required Syntax
Heading	Tape <tapename> where <tapename> is a global tape name
Column	Name
Column data	<clipname> where <clipname> is the name for a clip NOTE This is added to the EDL Comment field starting with "From Clip Name"
Column	Tape
Column data	Tape <tapename> where <tapename> is the tape name for the event NOTE If the ALE file also contains a global tape name, the global tape name is ignored.
Column	Tracks
Column data	VA1A2

If no Tape token is present, the tape will be named 001. If Name is missing, no name will be given to clips. If Tracks is missing, all events are assigned to V.

The following is an example of a valid ALE file:

Heading

VIDEO_FORMAT NTSC
TAPE 001

Column

Name	Start	End	Tracks	Tape	Data
Clip 1	10;03;05;01	10;04;06;19	VA1A2	003	
Clip 2	10;06;08;23	11;09;25;29	V	001	

To load an ALE file:

- 1 In the Editing menu, click EDL. Alternately, in the clip library, click Import EDL.
- 2 In the Import EDL menu, click Load.
- 3 From the EDL Type box, select ALE.

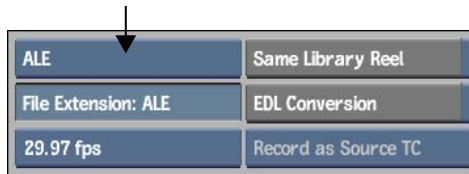

- 4 Use the file browser to go to the directory that contains the ALE file.
- 5 Select the ALE file that you want to translate.
If it is a valid ALE file, it is loaded into the EDL module. If it is not a valid ALE file, an error message appears in the message bar.

Loading FLX, ATN, and TLC Files

You can load FLX, ATN, or TLC telecine files into the EDL module. The source information from the files is extracted to create the EDL.

The following information is imported from the telecine log:

- Tape name

- Clip name
- Source timecode
- Keycode
- 2:3 pulldown removal information (whether there is 2:3 pulldown, the reference frame timecode, the reference type, and the drop frame reference timecode)

To load FLX, ATN, or TLC files:

- 1 In the Editing menu, click EDL. Alternately, in the clip library, click Import EDL.
- 2 In the Import EDL menu, click Load.
- 3 From the EDL Type box, select FLX, ATN, or TLC.

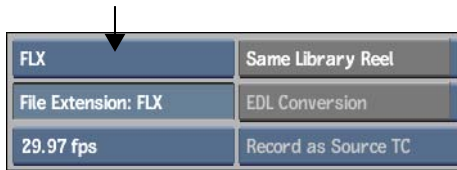

- 4 Use the file browser to go to the directory that contains the FLX, ATN, or TLC file.
- 5 Select the file that you want to translate.
If it is a valid file, it is loaded into the EDL module. If it is not a valid file, an error message appears in the message bar.

Loading EDM Files

You can import EDLs and setup information into your projects using EDM and AUX files exported from edit 6.0 (or later). You only need to import the EDM file—the AUX files are read automatically during the import of the EDM file. The EDM and AUX files must be located in the same directory.

When you first import the EDM file, each edit Video track and Sub-Timeline is a separate EDL. To work with the imported EDLs, you must multi-assemble them into one master EDL, applying the Convert EDM and Assemble Selected EDLs commands. This allows you to capture all the associated material at the same time.

When you assemble the EDLs, the associated Video tracks are converted into layers, Audio tracks are converted into audio tracks, and Sub-Timelines are converted into containers. Colour Correction, Text (Inscriber®), and other effects from Combustion are converted into setup files and associated with the appropriate timeline element. CG Inscribe text may be imported and converted into a Text setup.

NOTE CC setups are automatically applied to the clip but Keyer and Stabilizer Setups must be loaded manually.

To import an EDM file:

- 1 In the Import EDL menu, close all open EDLs.
- 2 Click Load to display the file browser.
- 3 From the EDL Type box, select EDM.

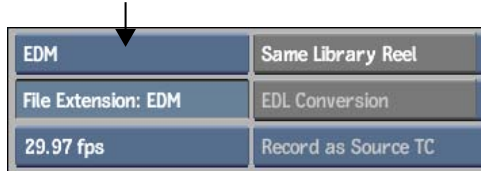

- 4 Enable Same Library Reel.
- 5 Locate the directory containing the EDM and AUX files.
- 6 Select the EDM file that you want to import.
The EDLs included in the EDM file are loaded and the setups in the associated AUX files are converted and copied into the setup directories of the current project.
- 7 Capture the clips using the Auto-Capture menu. If multiple EDLs were imported, enable Multiple EDLs in the Auto-Capture menu. See [Auto-Capturing an EDL](#) on page 380.
- 8 Go back to the Import EDL menu and select <M-assemble> from the EDL box.
- 9 In the Multi-Assembly menu that appears, click Convert EDM.
All the EDLs belonging to the EDM file are selected and assigned to containers or layers in a track, in the order found in the original EDM file.

TIP You can specify a different order of tracks or layers by clicking the EDL in either the Track or Layer column. Clicking the Track column assigns the EDL to a new track. Clicking the Layer column assigns the EDL to a layer belonging to the highest existing track number in the set of EDLs belonging to the EDM.

The edit tracks are assembled into corresponding layers, Sub-Timelines are assembled into containers, and the setups are associated with the appropriate timeline elements.

- 10 Click Assemble Selected EDLs to assemble the clip.
- 11 Exit to the clip library.
The assembled clip appears in the library reel you specified.
- 12 Bring the assembled clip to the Record Area of the Desktop. For information on working with the clip on the timeline, see [Navigating the Timeline](#) on page 969.

Searching EDLs

Use the Search Events menu to search entries for text or timecode in an EDL. When you search the EDL, you need to specify the item that you want to search, the filter type you want to use, and the criteria for which you want to search.

To search an EDL:

- 1 In the Import EDL menu, click Search Events.
- 2 Specify the item that you want to search for in the Search Item box. See [Search Events Menu](#) on page 330.
- 3 When you perform a search on Speed, toggle the Display Speed button to display the speed in FPS or as a percentage.
- 4 Alphabetical searches are performed on Tape and Comment items by default. To perform a numeric search on these items, enable Treat As Numeric.
- 5 Specify the filter type. The filter type will differ depending on the item you are searching.
- 6 Enter the search criteria in the Search Criteria field.

- 7 To match results by case, enable Case Sensitive.
- 8 Select the option that you want from the Select Item box.
- 9 Click Select Matches to find the items.
- 10 Use the Next and Previous buttons to navigate the selected matches.

Closing EDLs

Once you open an EDL in the Import EDL menu, it remains open until you close it. You can close one or all open EDLs.

To close an EDL:

- 1 Make sure the EDL you want to close is selected in the Current EDL box.
- 2 Click Close, and then confirm the action to close the EDL.
You can also hold down the Close box and select Close All, then confirm the action to close all opened EDLs.

Reopening EDLs

After you close an EDL you can reopen it by selecting it in the History list. The History list appears when you hold down the Load button. The last four opened EDLs appear in the History list.

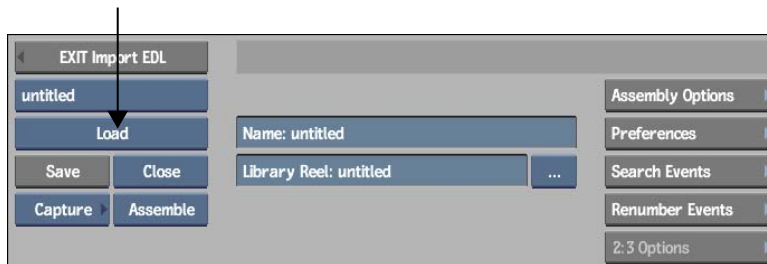

To reopen an EDL that was recently closed:

- 1 Hold down the Load button, and select the EDL that you want to open.

To clear the History list:

- 1 Hold down the Load button, and then select Clear History.

Creating and Editing EDL Files

15

Topics in this chapter:

- [About Creating and Editing EDLs](#) on page 349
- [About EDL Editing Commands](#) on page 350
- [Creating an EDL](#) on page 360
- [Editing an EDL](#) on page 361
- [Creating and Editing DLEDLs](#) on page 370
- [Saving EDLs and Tape Lists](#) on page 375

About Creating and Editing EDLs

You can create and edit EDLs. You can also save new EDLs as files or output them to tape. The Import EDL module extends these capabilities by allowing you to create and edit information in EDLs directly in the module. You can even create a blank EDL and add events, transitions, and comments. Essentially, this is similar to editing, only you are doing it without the audio-visual cues that you get on the Desktop.

About EDL Editing Commands

There are a large variety of EDL editing commands available in the Import EDL menu. These are categorized into the following eight groups:

- Events
- Titles
- Capture
- Editing
- Transitions
- Comments
- EDL
- Display

Events Group

Use the commands in the Events group to cut or copy single or multiple events and paste them to a new location in any open EDL. You can also use special paste functions and selection tools for events.



Insert Event button Inserts a new event into the EDL.

Cut Event button Cuts the selected event. May be used with Paste Event button.

Copy Event button Copies the selected event. May be used with Paste Event button.

Paste Event button Pastes the previously cut or copied event to the selected location.

Paste: Fix Record button Enable to change Record In of the first pasted event to start at Record Out of the previous event. All pasted events are then rippled by the same amount.

Paste: Renumber button Enable to automatically renumber all events according to the Next Event value in the Renumber Events menu. If this option is disabled, the pasted events retain their original event numbers. See [Renumber Events Menu](#) on page 332.

Select All button Click to select all events for capture.

Unselect All button Click to unselect all events.

Auto-Paste button Enable to quickly cut events from multiple EDLs and automatically paste them to a single EDL. For a selected EDL, when clicking the Paste button, any events that are cut or copied are automatically pasted to the first EDL.

Transitions Group

Use the commands in the Transitions group to change any transition to a cut, dissolve, or standard SMPTE wipe.



Cut button Changes the transition type to a cut for the selected transition, or range of transitions.

Dissolve button Changes the transition type to a dissolve for the selected transition, or range of transitions.

Wipe button Changes the transition type to a wipe for the selected transition, or range of transitions. The wipe type is set to SMPTE 001.

Choose button Opens the Choose Wipe menu from which you can select from a variety of standard SMPTE wipe types.

Titles Group

You can add or delete a title from an EDL using commands in the Titles group of the Import EDL menu.



Insert Title button Enter a new title in the Titles area of the EDL work area. You can add multiple titles. To edit a title, double-click it and enter the new title.

Delete Title button Delete a title in the EDL work area.

Comments Group

You can add or delete comments from events using the commands in the Comments group of the EDL menu. Comments can contain up to 256 alphanumeric characters. You can also toggle comments on or off.

EDL comments become part of the source clip when assembling the EDL. Multiple comment lines are merged into one timeline comment line.



Insert Comment button Add a comment to the event selected in the EDL work area. You can add multiple comments to an event. To edit a comment, double-click it and enter the new comment.

Delete Comment button Delete a comment selected in the EDL work area.

Hide button When enabled, will hide all comments in the EDL work area.

Clean button Removes asterisks from comments.

Capture Group

You can mark events for capture or select only the uncaptured ones for recapture.



Mark button Click to mark the selected events for recapture with an “X”. This allows you to keep track of events that you want to recapture. Events that have already been captured are marked with a lower case x. Therefore, when you mark a captured event for recapture, a lower and upper case x appear (x X) to the right of the event number.

Event #	Tape	A.Patch
TITLE COL_NOISE		
0001 x X	ZOZO	
FROM CLIP NAME: COL_NOISE		

(a) Capture mark (b) Recapture mark

Unmark button Click to remove a recapture mark from the selected events.

Select Uncaptured button Click to select all uncaptured events in the EDL. The next time you click Auto-Capture, only the selected events are captured.

Update Capture Marks button Click to update the list of captured events.

EDL Group

You can use any of these options in the EDL group when using EDLs to capture media.

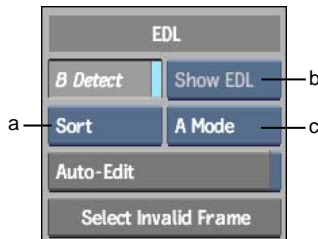

(a) Sort box (b) Show Timecode box (c) Sort Mode box

BRoll Detect button Enable to detect BRolls. BRolls appear as the original tape. You are not prompted for the tape containing the BRoll when you capture the clips. When disabled, BRolls are indicated with a “B” following the tape name in the Tape entry.

Show Timecode box Select the type of timecode to display.

Select:	To:
Show EDL	Display EDL timecode.
Show VC	Display Varicam timecode.

Sort box Click Sort to sort the current EDL, or click Sort All to sort all the EDLs. EDLs are sorted according to the sort order specified in the Sort Mode box. You can change the way an EDL is sorted.

Auto-Edit button Enable to quickly modify only the entries in the selected columns of the EDL. Click the column headers of the columns that you want to auto-edit. Starting with the first entry that you edit, press **Enter** to move automatically to the next entry. If no further entries exist, a new event is added.

Sort Mode box Select the appropriate sort order.

Select:	To sort the EDL:
A Mode	By Record In timecode. If you want to view the EDL in the order of the final assembly, sort the EDL in A Mode.
B Mode	By Tape and Record In timecode.
C Mode	By tape number and Source In timecode. If you want to view the EDL in the order the clips are captured, sort the EDL in C Mode. EDLs are always captured in C Mode, regardless of the sort mode you selected.
S Mode	By Source In timecode, regardless of tape number. This sort mode is useful for multi-camera real-time EDLs.
by Event#	By event number.
by Tracks	By tracks. In this sort mode, video tracks are placed at the bottom of the list, and the highest audio track is placed at the top of the list.
by Uncaptured	By placing all uncaptured events at the top of the list.

Select Invalid Frame button Click to select a frames of 0 length.

Editing Group

When you modify an entry in an EDL, several options control how other entries are affected. Make sure these options are either enabled or disabled, depending on how you want to edit the EDL.



Slip Tape button Enable to slip all source clips on the tape, or all record clips in the EDL list. All the in and out points of all source or record clips change without affecting their duration.

Lock Speed button Enable to edit the timecode without changing the speed value for the event.

Slip button Enable to slip a source or record clip in a single event. The in and out points of the selected clip change without affecting its duration.

Ripple Rec button Enable to move all Record entries, following an edited or pasted Record Out entry, forward or backward accordingly. This is useful when you want to edit the Record Out of an event without overwriting or creating a gap between the following shots.

Affect Sel button Enable to affect only the selected events.

Affect Tape button Enable to affect every relevant entry on the same tape when you modify a single entry.

View Sel button Enable to view only the selected events.

Display Group

The Display group contains options for modifying the display of events in the EDL list.

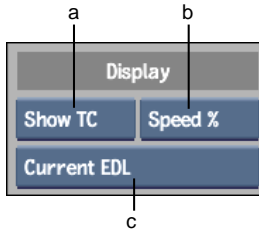

(a) Show TC/KC box (b) Speed box (c) EDL Display box

Show TC/KC box Select whether to display keycode or timecode.

Select:	To:
Show TC	Display timecode.
Show KC	Display keycode.

Speed box Select a mode to display the speed change for timewarps.

Select:	To:
Speed %	Display the speed change as a percentage.
Speed FPS	Display the speed change in frames per second.

EDL Display box Select a display mode for EDLs, Tape List view, or Undo List view.

Select:	To:
Current EDL	Display timecode.
View Undo List	View all modifications (up to the number of undo levels specified in the Preferences menu) that you made in the current session, and undo a single or series of commands. Click the item in the undo list that you want to undo. All operations are undone up to and including that modification. All operations prior to the highlighted modification are redone.
View Tape List	Display the Tape List view.
Multip EDL	Display keycode.

EDL View

An EDL contains events, edits, and entries. An event is a complete element in the EDL such as a shot, dissolve, or wipe. An edit is an individual component that makes up an event, such as an outgoing shot or an incoming shot. An entry is an individual value for any variable in the edit, such as dissolve length, Source In, or Speed.

0011	250	V	C	01:00:06:06	01:00:08:03	00:01:18:04	00:01:20:01
0012	250	V	C	01:00:05:14	01:00:15:09	00:01:00:00	00:01:09:15
0012	250	V	D 10 (C)	01:00:20:07	01:00:25:05	00:01:09:15	00:01:14:13

(a) Edits (b) EDL events (c) EDL entries

Every event has a different event number. Some events, such as dissolves and wipes, consist of two edits. The two edits in a dissolve (outgoing and incoming shots) have the same event number.

Undo List View

Use the Undo List to view all modifications (up to the number of undo levels specified in the Preferences menu) that you made in the current session and undo a single or series of commands.

Click the item in the Undo List that you want to undo. All operations are undone up to and including that modification. All operations prior to the highlighted modification are redone.

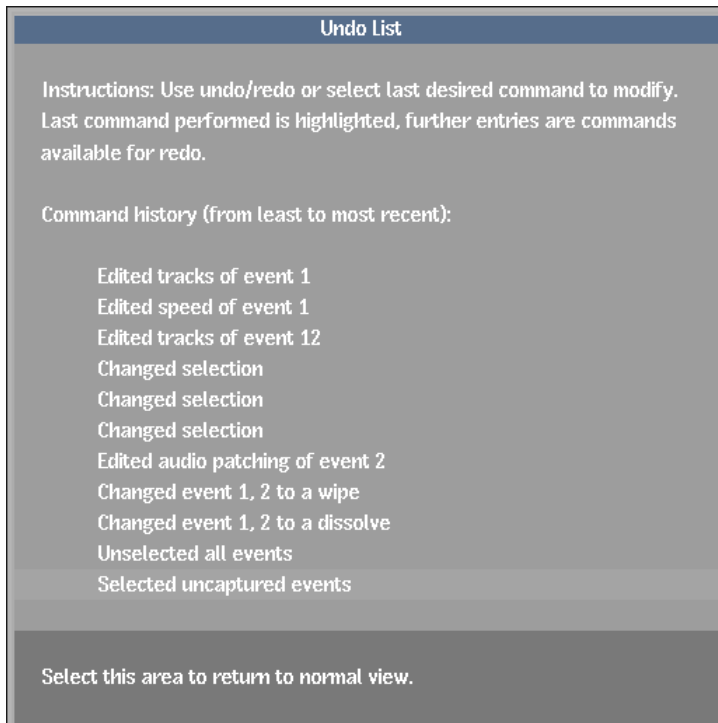

Tape List View

Use Tape List view to see all the tapes needed to assemble the current EDL or all currently open EDLs. In a regular EDL, you can see how raw source footage should be captured into an edited record timeline using timecode. Generally, the source footage is listed in an EDL based on its chronological order in the timeline.

You can use the tape list to modify information pertaining to events for a given tape.

As well, each tape's entry can be expanded in Tape List view to show keycode and 2:3 pulldown information associated with the source timecode.

Click the column header to sort the tape list in descending order using that column. Click the column heading again to sort the tape list in ascending order.

///	Tape ▾	Capture	FCM	Tracks	Start
▼	MASTER	On	23.976 fps	V1	00:00:03+17
○		TC Start	TC Duration	Film FCM	Keycode
○		03:59:59+14	00:00:00+15	N/A	N/A
○		04:00:00+04	00:00:01+10	23.976 fps	KK248181 6659+03 (1)
○		04:00:01+14	00:00:14+00	23.976 fps	KK248181 6660+14 (2)
○		04:00:15+19	00:00:18+15	23.976 fps	FN723405 8172+12 (2)
○		N/A	N/A	N/A	N/A

The work area of the Tape List view is divided into nine columns, and two sections for each tape.

The upper fields of each tape entry contain the following columns.

Tape The name of the tape that contains the source footage. To change the tape name, click and enter a new name.

Capture The capture flag for the tape. When set to On, the tape is captured during an auto-capture session. To set the capture flag for a given tape to On or Off, click the item under the Capture column and drag left or right to set it On or Off.

FCM The frame code mode for the tape. If the frame code mode is 29.97, you can drag over the item in this column to switch between DF/NDF modes.

Tracks The number and type of tracks that will be captured for the tape.

Start The starting timecode for the first event to be captured on the given tape.

Capture Time The duration of the material to capture for the given tape.

Telecine Indicates the telecine log associated with the tape.

Final Telecine Indicates the final telecine log associated with the tape.

Events The number of events to capture for the given tape. You cannot modify this value in Tape List view.

The lower fields of each tape entry contain the following columns.

TC Start Start timecode for each keycode sequence.

TC Duration Duration of time for the keycode sequence.

Film FCM Film frame code mode indicating the speed of the telecine when it scanned the film frames. Change the film FCM by clicking the Keycode field to access the calculator. See [About the Keycode Calculator](#) on page 410.

Keycode Keycode for the first frame of the sequence.

Removal Whether to apply 2:3 pulldown to the sequence.

Ref Frame Timecode of the reference frame.

Ref Type Type of reference frame.

DF Ref Frame Timecode of the drop frame reference frame.

NOTE For more information on the 2:3 pulldown fields in Tape List view, see [Overriding Default 2:3 Pulldown Configuration Tape-to-Tape](#) on page 710.

Creating an EDL

You can create an EDL in the Import EDL module. This is useful when you have an EDL printed on paper (but no electronic file) and you need to capture the material. With the EDL module, you can manually recreate the EDL with all the information needed so that you can automatically recapture.

To create an EDL:

- 1 In the Import EDL menu, select <new> from the EDL box.

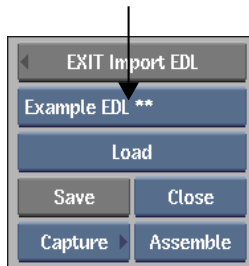

A blank EDL is created.

- 2 Use the EDL Editing tools to insert, cut, copy, and paste events, comments, titles, and transitions into the new EDL. See [About EDL Editing Commands](#) on page 350.
- 3 Edit the EDL events as needed. See [Editing an EDL](#) on page 361.
- 4 Click Save to save the new EDL. See [Saving EDLs and Tape Lists](#) on page 375.

Editing an EDL

Once you import an EDL, you can edit any value except the event number. This includes:

- The tape name for single or multiple events
- The audio patching information
- The transition duration and speed value of dissolves
- A cut to a dissolve or wipe
- The source and record timecodes of events

These tasks are described in the following sections. You can open multiple EDLs and copy and paste events between them. You can also use Auto Edit mode to quickly make changes to the entries you specify.

NOTE EDLs with references to a generated output tape (EDLs created with the Export EDL feature using the Output All or Output Generated option) are opened as read-only and cannot be edited. To edit a read-only EDL, save it to the filesystem with a different name.

Editing a Tape Name

You can change a single event's tape name, or the tape name for all events on the same tape. This is useful if the events you want to capture are on a different tape than that listed in the EDL.

Tape names can be up to 56 characters long. The EDL Editor displays only the first eight characters, but the clips maintain the original tape name.

To edit a tape name:

- 1 In the Import EDL menu, do one of the following:
 - To change the tape name for all events on the same tape, enable Affect Tape.
 - To change only the selected tape name, disable Affect Tape.

- 2 Click the Tape entry in the event you want to edit and enter the new name:
 - If the Affect Tape option is enabled, the tape name for all events on the same tape changes automatically.
 - If the Affect Tape option is disabled, only the tape name for the selected event changes.
 - If the Affect Selection option is enabled, only the tape names for selected events change.

Audio Patching

If you want to capture audio from a different track than that specified in the EDL, you can change the audio patching for a single event, selected events, or all events on the same tape. For example, if an edit specifies the audio tracks as 1 and 2, but you want to capture the audio from tracks 3 and 4, use the Audio Patching menu to reroute the audio during auto-capture.

NOTE You can also specify the patch tracks from the Engineering menu when you want to affect the whole capture session. See [Audio Track Patching](#) on page 384.

To change audio patching:

- 1 In the EDL work area, select the events that you want to modify.
- 2 Click an Audio Patch field.

Event #	Tape	A.Patch	Tracks	Transition	Source In	Source Out
TITLE: 1010						
0001 x	BL		V	C	00:00:00:00	00:00:00:10
0001	250		V	D 10 (F)	01:02:07:29	01:02:08:15
FIREEDL: FOCUS_DESCR FROMCUT						
0002 x	BL		V12	C	00:00:00:00	00:00:00:11
0002	250		V	D 10 (F)	01:00:05:07	01:00:06:03
FIREEDL: FOCUS_DESCR FROMCUT						
0003 x	BL		V	C	00:00:00:00	00:00:00:11
0003	250		V	D 10 (F)	01:01:01:11	01:01:02:12
FIREEDL: FOCUS_DESCR FROMCUT						

The Audio Patching menu appears.

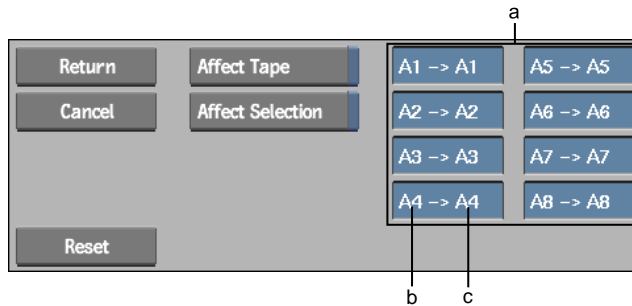

(a) Audio Patch boxes (b) Source audio track (c) Destination audio track

You can edit the source audio tracks. Each one of the eight available source audio tracks can be patched to one of the eight available destination audio tracks. You can patch the same source audio track to multiple destination audio tracks.

- 3 Enable or disable the Affect Tape and Affect Selection buttons. See [Editing Group](#) on page 355.
- 4 Reroute the audio in the Audio Patch boxes by doing one of the following:
 - Drag in an Audio Patch box to cycle through source audio tracks one through eight.
 - Click an Audio Patch box to access the calculator, then type a value one through eight indicating the source audio track.
- 5 Click Return.

To exit the Audio Patching menu without changing the patching information, click Cancel.

The source tracks that have been patched to different audio tracks than the defaults are indicated in the affected event's Audio Patch Field. Dashes in the Audio Patch Field indicate the track is patched to its default. Comments are also added which indicate the name of audio tracks and their patching information.

When clips are captured, audio tracks are patched as indicated.

Event #	Tape	A Patch	Tracks	Transition	Source In	Source Out	Speed	Record In	Record Out
TITLE: FINAL SHOW audio tracks 1 & 2									
0001	LORES	65-----	12	C	01:00:00:00	01:07:07:16		01:00:00:00	01:07:07:02
* FROM CLIP NAME: Lo Res Show									
* PATCH LORES: FROM SOURCE 6 TO RECORD 1									
* PATCH LORES: FROM SOURCE 5 TO RECORD 2									
0002	LORES	65-----	12	C	01:07:37:00	01:12:15:21		01:07:37:00	01:12:15:13
* FROM CLIP NAME: Lo Res Show									
* PATCH LORES: FROM SOURCE 6 TO RECORD 1									
* PATCH LORES: FROM SOURCE 5 TO RECORD 2									

(a) Comments indicate patching information (b) Source 1 and 2 patched to destinations 5 and 6

Editing Tracks

You can edit the tracks of an event in the EDL. Editing tracks is useful if you want to modify the tracks captured when you auto-capture or assemble the EDL.

For example, if the Track entry for an event is V1 and you want to capture only the video track (V), change the Track entry to V.

To edit the tracks for an event:

- 1 In the EDL work area, select the Track entries in the event that you want to edit from the EDL.

The Track menu appears.

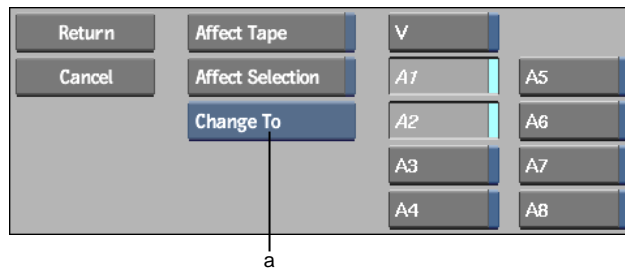

(a) Edit Mode box

- 2 Enable the tracks that you want to edit.
- 3 Enable or disable the Affect Tape and Affect Selection buttons. See [Editing Group](#) on page 355.

- 4 From the Edit Mode box, select the mode that you want to use.

Select:	To:
Change To	Replace tracks in the event with tracks you specified in the Track menu.
Add	Add the tracks you specified in the Track menu to the tracks in the event.
Filter	Keep only the tracks you specified in the Track menu. For example, if an event is "V12" and you specify "V1," audio track 2 is filtered out, and the resulting event has "V1."
Flip	Reverse the status of tracks you specified in the Track menu. For example, if an event is "V23" and you specify "V34," the resulting event has "V24."

- 5 Click Return to confirm the change or Cancel to exit back to the EDL module without making any modifications.

Editing Transitions in EDLs

You can change any transition to a cut, dissolve, or SMPTE wipe. If the effect of an event is a dissolve, you can edit its duration (Transition Duration). If the effect of an event is a wipe, you can also select the type of wipe in the SMPTE Wipe library.

You can add or modify transitions based on a selection range.

You can also change a cut to a dissolve by clicking the Transition entry of the cut. You can change a dissolve to a cut by setting the Transition Duration to 0, as long as the Allow Zero-Length Transitions option is disabled in the EDL preferences. See [Preferences Menu](#) on page 328.

Dissolves in EDLs

Dissolves are represented in the EDL by two consecutive edits with the same event number. The first edit represents the outgoing shot of the dissolve and the second edit represents the incoming shot of the dissolve. The dissolve is listed in the Transition column of the second edit as D *n* (where *n* is the transition duration).

The Transition duration appears in the Transition entry of the second edit in the dissolve. The Start Location for the dissolve is also indicated in the Transition entry.

If the EDL was exported from Flame, the dissolve can be Centred, From Cut, or Up To Cut. The start location for the dissolve appears beside the Transition duration.

The following illustration is a typical dissolve in an EDL.

a	0001 x	BL	C	00:00:00+00	00:00:01+00	01:00:59+15	01:00:59+15
	0901	BC01	D 24	01:00:27+21	01:00:50+00	01:00:59+15	01:01:21+18
	* BLEND DISSOLVE						
b			c				

(a) Outgoing shot (b) Incoming shot (c) Transition duration

If you change the Transition duration of a dissolve, the Source Out of the incoming shot changes by the same duration automatically.

Wipes in EDLs

Wipes are represented in the EDL by two consecutive edits with the same event number. The first edit represents the outgoing shot of the wipe and the second edit represents the incoming shot of the wipe. The wipe is listed in the Transition column of the second edit as *W n m* (where *n* is the wipe code and *m* is the wipe duration).

The SMPTE wipe number appears in the Transition entry of the second edit in the wipe. The Start Location for the wipe is also indicated in the Transition entry. A wipe can be Centred, From Cut, or Up To Cut. The start location for the wipe appears beside the Transition duration. The following illustration is a typical wipe in an EDL.

a	0001 x	BL	C	b	00:00:00+00	00:00:01+00	01:00:59+15	01:00:59+15
	0001	BC01	W 001	24	01:00:27+21	01:00:50+00	01:00:59+15	01:01:21+18
	* BLEND DISSOLVE							
				d				
				c				

(a) Outgoing shot (b) Transition duration (c) Incoming shot (d) SMPTE wipe number

If you add 500 to the SMPTE wipe number, the wipe is inverted during assembly. For example:

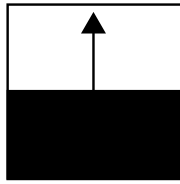

Wipe 002

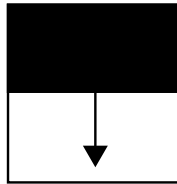

Wipe 502

If you change the Transition duration of a wipe, the Source Out of the incoming shot automatically changes by the same duration.

Editing Timecode

If you want to capture different material than what appears in the EDL, you can slip or trim the edits to specify the correct material for your final assembly. You can change any source or record timecode in the EDL.

You can also edit timecode and keycode in the Tape List.

To edit timecode:

- 1 If you want to edit source timecode, and keycode in and out values are displayed, toggle the Show Timecode/Show Keycode box to Timecode.
- 2 Do one of the following:
 - Click the source or record timecode entry you want to modify and drag right to increase the value or drag left to decrease the value. You can use hot keys to change the values in varying increments.

Use:	To:
Shift-drag	Jump by seconds.
Ctrl-drag	Jump by minutes.
Alt-drag	Jump by hours.

- Double-click the source or record timecode you want to modify to get the calculator, and then enter a new timecode. If the source or

record timecode is already selected, click it again to get the calculator. See [Calculating Timecode](#) on page 70.

When you edit source timecode, the corresponding keycode changes to reflect the new frames to be captured. Toggle the Show Timecode/Show Keycode button to see the edited keycode in and out values. You cannot edit the keycode for events in the EDL work area.

NOTE Other entries in the same edit affected by your modifications become highlighted as you edit an entry.

Editing Tape List Timecode and Keycode

In Tape List view, you can slip all the start timecode values for a given tape. This is useful when you need to modify the start timecode of a tape that is used in multiple EDLs, because you edit the value only once.

You can also slip keycode and its associated start timecode and duration. This is similarly useful to alter keycode values correlated to the timecode for given sequences on the tapes.

To slip the start timecode value for a given tape:

- 1 In the Import EDL menu, from the Display group, enable View Tape List.
- 2 Do one of the following:
 - Click the start timecode entry you want to modify and drag right to increase the value or drag left to decrease the value. You can use hot keys to change the values in varying increments.

Use:	To:
Shift-drag	Jump by seconds.
Ctrl-drag	Jump by minutes.
Alt-drag	Jump by hours.

- Click the start timecode entry you want to modify to get the calculator, then enter a new timecode. See [Calculating Timecode](#) on page 70.

To slip the keycode for a given tape:

- 1 In the Import EDL menu, from the Display group, enable View Tape List.

- If necessary, click the triangle on the left of the tape entry to expand its contents.

///	Tape ▾	Capture	FCM	Tracks	Start
	MASTER	On	23.976 fps	V1	00:00:03+17

Sequences of timecode on the tape are associated to keycode values. If no keycode is available from the telecine log(s) you loaded, N/A (not available) appears for the sequence.

///	Tape ▾	Capture	FCM	Tracks	Start
▼	MASTER	On	23.976 fps	V1	00:00:03+17
○		TC Start	TC Duration	Film FCM	Keycode
b ○		03:59:59+14	00:00:00+15	N/A	N/A
○		04:00:00+04	00:00:01+10	23.976 fps	KK248181 6659+03 (1)
a ○		04:00:01+14	00:00:14+00	23.976 fps	KK248181 6660+14 (2)
○		04:00:15+19	00:00:18+15	23.976 fps	FN723405 8172+12 (2)
○		N/A	N/A	N/A	N/A

- Timecode start and duration defines sequence, with corresponding keycode
- Timecode without corresponding keycode

- To edit the keycode for a sequence, do one of the following:
 - Drag the keycode entry you want to modify to the right to increase the value or to the left to decrease the value.
 - Click the keycode entry you want to modify to get the keycode calculator, and then enter a new keycode. See [About the Keycode Calculator](#) on page 410.

The keycode values associated to the timecode sequence (defined by the values in TC Start and TC Duration fields) are altered.

If you change the frame rate in the keycode calculator, it is reflected in the Film FCM field.

Film FCM	Keycode
N/A	N/A
23.976 fps	KK248181 6659+03 (1)

Editing and Creating Timewarps

You can edit an existing timewarp or create a timewarp in your EDL. When you edit a timecode entry of an event with the Lock Speed option disabled, no other entries are affected. This results in a speed change because the source duration differs from the record duration.

For example, if you increase the Source In entry of an event by 5 seconds, the record clip of the same event is 5 seconds shorter than the source clip. The result clip is timewarped when assembled. No other entries are affected. See [Assembling EDLs](#) on page 386.

Timewarps are represented in the Speed column of the EDL. If the Speed value is blank, the event is not timewarped. If there is a Speed value, the event is timewarped.

0018	003	V	C	14:06:14:13	14:06:14:17	50.0%	10:00:16:07	10:00:16:15
------	-----	---	---	-------------	-------------	-------	-------------	-------------

a

(a) Speed value

To edit or create a timewarp:

- 1 In the Import EDL menu, from the Editing group, disable Lock Speed.
- 2 In the EDL, click the source or record timecode entry for the event that you want to edit and enter the new value.

The value of the timewarp appears in the Speed entry. You may also click directly in the Speed box to change the entry. If the event is already a timewarp, editing any timecode of that event changes its speed value.

You can view the speed value in either percentage or frames per second. Select the View mode in the EDL Preferences menu. See [Preferences Menu](#) on page 328.

Creating and Editing DLEDLs

DLEDLs can be used in a workflow where you need to import multiple media files in a single pass. They consist of comments that are used to enhance basic EDLs.

DLEDL Structure

The DLEDL is an EDL file based on the CMX 3600 format supported by most digital non-linear editing systems. The following table lists the DLEDL flags used in creating an EDL file. It describes the comments used in creating DLEDLs and provides examples of basic EDLs that you can use in your projects.

Note that the order of flags always remains the same:

- Clip name (EDL comment)
- Start TC
- File path
- Video file name
- Audio 1 file name
- Audio 2 file name
- Audio 3 file name
- Audio 4 file name

DLEDL Flag Example	Description
DLEDL: START TC: 10;00;00;00	The start timecode of the clip that will be created from the media files imported into the Autodesk Visual Effects and Finishing application. This timecode can be different from the source start timecode of the EDL event. Both drop-frame (00:00:00:00) and non-drop-frame (00;00;00;00) timecodes are supported.
DLEDL: PATH /CXFS1/PRODUCTION1/SHOW5	The location of the files on the filesystem. All the files for an event must be in the same directory.
DLEDL: EDIT:0 FILENAME: INTRO.(010@240).dpx or DLEDL: EDIT:0 FILENAME: (009@100).dpx	Name of the video file sequence to load. Numbers in parenthesis refer to frames in the sequence. In this example, the following files are referenced: <i>INTRO.010.dpx, INTRO.011.dpx, ..., INTRO.240.dpx</i> or <i>009.dpx, 010.dpx, ..., 100.dpx</i>

DLEDL Flag Example	Description
DLEDL: EDIT:0 FILENAME: TONE-8TRK-44KHZ.AIFF_CHANNEL_1.AIF	Audio file name to import. The audio files can contain one file per track (_1), one file per stereo pair (_12), or one file per multiple tracks (_1234). Supported formats are wave (.WAV) or AIFF (.AIF).
DLEDL: REEL: 12345678 123456781234556	The CMX EDL format limits the length of the tape name to eight characters (Smoke has the same limit). Some editing systems do not impose a tape name length limit. If the tape name exceeds eight characters, Smoke generates a short name to be used in the EDL and stores the original name in the Source Table list at the end of the EDL file (one Source Table per EDL).

NOTE File names, tape names, and clip names cannot contain spaces or special characters. For example, TAPE 1 should be set to TAPE_1 (no space) and CLIP\$,12/2 to CLIP_12_2 (no special characters).

Using DLEDLs Examples

The following examples are given to facilitate the creation of edit decision lists for the automatic import of multiple media files into a project. You can simply copy and paste the suitable example into a text editor, modify it accordingly, save the file with an *.edl* extension, and import the resulting file into your application.

Video-only EDL

```
TITLE: SIMPLE EDL VIDEO ONLY
FCM: DROP FRAME
001 TAPENAME V C 10:00:00:00 10:00:05:00 00:00:30:00
00:00:35:00
* FROM CLIP NAME: clip
DLEDL: START TC: 10;00;00;00
```

DLEDL: PATH: /CXFS1/PRODUCTION1/SHOW5
DLEDL: EDIT:0 FILENAME: INTRO.(010@240).dpx
DLEDL: REEL:TAPENAME TAPENAMEEVERYLONG

Simple Video and Audio (2 Tracks) EDL

TITLE: SIMPLE EDL WITH VIDEO AND 2 AUDIO TRACKS (1
TRACK PER FILE)
FCM: DROP FRAME
001 TAPENAME AA/V C 10:00:00:00 10:00:05:00 00:00:30:00
00:00:35:00
* FROM CLIP NAME: TONE-8TRK-44KHZ.AIFF
DLEDL: START TC: 10;00;00;00
DLEDL: PATH: /CXFS1/PRODUCTION1/SHOW5
DLEDL: EDIT:0 FILENAME: INTRO.(010@240).dpx
DLEDL: EDIT:0 FILENAME:
TONE-8TRK-44KHZ.AIFF_CHANNEL_1.AIF
DLEDL: EDIT:0 FILENAME:
TONE-8TRK-44KHZ.AIFF_CHANNEL_1.AIF
DLEDL: REEL:TAPENAME TAPENAMEEVERYLONG

Simple Video and Audio (4 Tracks) EDL

TITLE: SIMPLE EDL WITH VIDEO AND 4 AUDIO TRACKS (1
TRACK PER FILE)
FCM: DROP FRAME
001 TAPENAME AA/V C 10:00:00:00 10:00:05:00 00:00:30:00
00:00:35:00
* FROM CLIP NAME: TONE-8TRK-44KHZ.AIFF
DLEDL: START TC: 10;00;00;00
DLEDL: PATH: /CXFS1/PRODUCTION1/SHOW5
DLEDL: EDIT:0 FILENAME: INTRO.(010@240).dpx

```
DLEDL: EDIT:0 FILENAME:
TONE-8TRK-44KHZ.AIFF_CHANNEL_1.AIF

DLEDL: EDIT:0 FILENAME:
TONE-8TRK-44KHZ.AIFF_CHANNEL_2.AIF

DLEDL: EDIT:0 FILENAME:
TONE-8TRK-44KHZ.AIFF_CHANNEL_3.AIF

DLEDL: EDIT:0 FILENAME:
TONE-8TRK-44KHZ.AIFF_CHANNEL_4.AIF

AUD 3 4

DLEDL: REEL:TAPENAME TAPENAMEEVERYLONG
```

Simple Video and Audio (2 Tracks - Stereo) EDL

```
TITLE: SIMPLE EDL WITH VIDEO AND 2 AUDIO TRACKS (2
TRACKS PER FILE)

FCM: DROP FRAME

001 TAPENAME AA/V C 10:00:00:00 10:00:05:00 00:00:30:00
00:00:35:00

* FROM CLIP NAME: TONE-8TRK-44KHZ.AIFF

DLEDL: START TC: 10;00;00;00

DLEDL: PATH: /CXFS1/PRODUCTION1/SHOW5

DLEDL: EDIT:0 FILENAME: INTRO.(010@240).dpx

DLEDL: EDIT:0 FILENAME: TONE_12.AIF

DLEDL: REEL:TAPENAME TAPENAMEEVERYLONG
```

Simple Video and Audio (4 Tracks - Stereo) EDL

```
TITLE: SIMPLE EDL WITH VIDEO AND 4 AUDIO TRACKS (2
TRACKS PER FILE)

FCM: DROP FRAME

001 TAPENAME AA/V C 10:00:00:00 10:00:05:00 00:00:30:00
00:00:35:00

* FROM CLIP NAME: TONE-8TRK-44KHZ.AIFF
```

```
DLEDL: START TC: 10;00;00;00
DLEDL: PATH: /CXFS1/PRODUCTION1/SHOW5
DLEDL: EDIT:0 FILENAME: INTRO.(010@240).dpx
DLEDL: EDIT:0 FILENAME: TONE_12.AIF
DLEDL: EDIT:0 FILENAME: TONE_34.AIF
AUD 3 4
DLEDL: REEL:TAPENAME TAPENAMEEVERYLONG
```

Saving EDLs and Tape Lists

You can save an EDL after you have made modifications to it. You can also save a tape list using the Save EDL menu. When you save a tape list, a tab-delimited ASCII file is created.

To save an EDL:

- 1 After modifying an EDL, click Save.
The Save EDL menu appears.

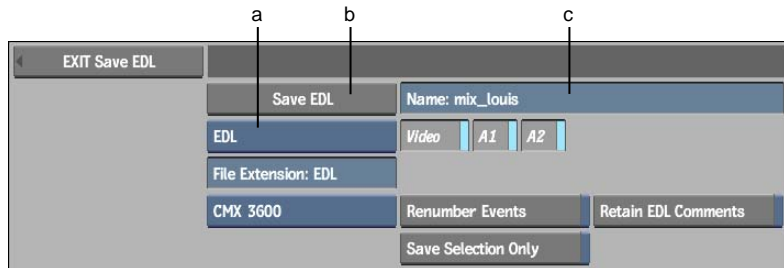

(a) EDL Format box (b) Save EDL button (c) Name field

- 2 Enter the name for the saved EDL in the Name field.
- 3 Select the EDL format from the EDL Format box.
- 4 Enable the tracks you want to include in the new EDL.
- 5 Enable Renumber Events to consecutively renumber events in the new EDL.

- 6 If you want to save only the selected portion of the current EDL, enable Save Selection Only.
- 7 Enable Retain EDL Comments if you want to keep the comments from the current EDL.
- 8 Click Save EDL.

To save a tape list:

- 1 In the Import EDL menu, click Save.
- 2 From the EDL Format box, select Tape List.
- 3 Enter a name for the tape list, and then click Save EDL.

Ensure that your file name does not contain any of the following characters: ` # ~ @ \$ % ^ & * () [] { } < > \ | / ! ? , ; : ' "

A Discreet Tape List (DTL) file is created. All information in the tape list, including timecode and keycode data, is saved. DTL files are ASCII files that can be opened in any text editor. DTL files can also be loaded in the EDL module to accompany EDLs.

Capturing and Importing Media Using EDLs

16

Topics in this chapter:

- [About Capturing and Importing Media Using EDL Files](#) on page 377
- [About the Auto-Capture Menu](#) on page 378
- [Capturing Clips Using an EDL](#) on page 380
- [Importing Files Using an EDL](#) on page 385
- [Assembling EDLs](#) on page 386
- [Viewing Captured and Assembled Material](#) on page 389

About Capturing and Importing Media Using EDL Files

Use an EDL to reconstruct a work session created in an offline editing system or to import image sequences from a standard filesystem.

Typically, when recreating a project from an EDL (referred to as conforming to an EDL), you import the file, capture the material or import the referenced files, and then assemble the captured or imported material into a clip on a destination library reel.

Using DLEDLs in your post-production workflow allows you to automate the import of media files (video and audio) residing in different locations. Instead of performing media import for each file separately, you can create a DLEDL and import all media files in a single operation, which allows you to significantly save processing time. See [Creating and Editing DLEDLs](#) on page 370.

Both FCP XML and AAF file formats are more modern EDL formats that support multiple layers of video and audio, as well as an expanded set of transitions and effects. See [Importing Final Cut Pro XML](#) on page 431 or [Importing AAF Files](#) on page 481.

You can use the telecine log to capture from tapes created during telecine sessions, and read the 2:3 pulldown removal information and keycode data contained in the files. See [2:3 Pulldown](#) on page 703.

About the Auto-Capture Menu

This is the Auto-Capture menu.

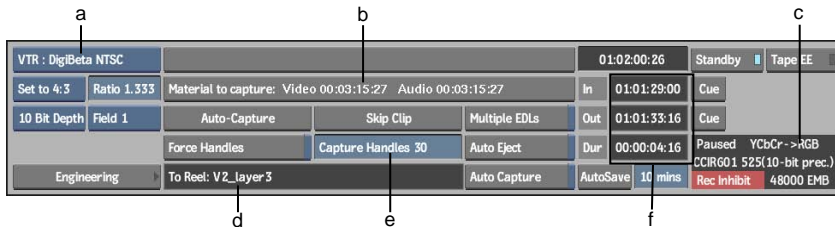

(a) Device Name box (b) Material to Capture status bar (c) VTR Status display area (d) Library Reel field (e) Capture Handles field (f) Timecode fields

Device Name box Select the device from which you will be capturing media.

Material to Capture status bar Displays the time remaining for capturing the selected video and audio.

Auto-Capture button Click to display the capture options. From the menu that appears, select the appropriate option for the capture.

Select:	To:
Capture This Tape	Capture clips on the currently loaded tape.
Skip This Tape	Skip the current cassette and proceed to the next tape.
Abort Capture	Abort the auto-capture.

Captured events are indicated in the event number column by an x sign.

NOTE If a clip for a selected event already exists in the clip library, it is not recaptured.

Skip Clip button Skips the clip being captured. The capture is aborted and the events are marked as “skipped.” The next time you click Auto-Capture, the capture is started at the first event following the skipped clip. To reset, exit and enter the Auto-Capture menu.

Multiple EDLs button Captures multiple EDLS.

VTR Status display area Displays the current status of the VTR. Different information is displayed under certain conditions. Depending on the model of the VTR, you may be able to change the Tape EE and Standby boxes. See [Verifying the VTR Status](#) on page 172.

Engineering button Click to display options for auto-capturing an EDL. See [Setting Video Input and Output Engineering Menu Controls](#) on page 175.

Library Reel field Displays the Library Reel.

Force Handles button Enable to ensure that the clip contains the number of handles that you want. The next time that you capture the EDL, the clips that do not have as many handles as defined in the Capture Handles field are recaptured. By default, clips are not recaptured if the specified material already exists on the reel, as defined in the Source In and Source Out entries of the EDL.

Capture Handles field Enter the number of extra frames to use as handles before and after the specified material. Capture handles are set by default based on the project frame code mode. If specifying more handles causes material to overlap, or if fewer than 10 frames separate events, the material is captured as a single clip.

When capturing using keycode data, if the keycode for the frames in the handles does not follow the keycode for the captured segment sequentially, then those handles are not captured.

Auto Capture button Enable to automatically begin capturing when you insert the tape into the VTR.

Auto Eject button Enable to automatically eject a tape after it has been captured. The last tape of a capture session is not ejected.

Capturing Clips Using an EDL

Use the Auto-Capture menu to load clips specified in an EDL. You can also use the multi-capture option to capture material from multiple EDLs.

Before a capture, the clip library reel specified in the Library Reel field is searched for clips that match those about to be captured. Only required clips are captured.

During auto-capture, the current position and in and out points are shown in the Timecode fields. Also, the remaining time in a capture session is displayed in the Time Remaining to Capture field.

Auto-Capturing an EDL

Before you auto-capture an EDL, make sure all the preferences are set correctly. Once you set the auto-capture options, you can capture the EDL.

To auto-capture an EDL:

- 1 From the clip library, click Import EDL.
- 2 From the Import EDL menu, click Load.
The EDL Load menu appears.
- 3 Select the EDLs that you want to load.
- 4 Optional: Enable Same Library Reel, if you want to load a series of EDLs and capture these open EDLs to the same reel in the clip library (using Multiple EDLs).
- 5 Click Load.
The selected EDLs are loaded into the Import EDL module.
- 6 Enter a name for the clip in the Name field.
- 7 Enter a library name in the Library Reel field.
- 8 In the EDL list, select the events that you want to capture. Do any of the following:
 - To select a single event, click the event number entry. Click the event number entry of another event to unselect the first entry.
 - To select a range of events, hold **Shift**, select an event, and click the last event in the range that you want to select. You can also click and drag to select a range of events.

- To add to a range of events, hold the **Ctrl** key or the pen button when you select an event.
- To select all events, use the Select All or Unselect All buttons.

NOTE When no event is selected, all events in the EDL are captured.

- 9 Optional: Use the Mark and Unmark buttons to keep track of events that you want to capture. See [Capture Group](#) on page 352.
- 10 Click Capture.
The Auto-Capture menu appears.
- 11 Ensure that the correct VTR is selected in the Device Name box.

NOTE Make sure the VTR is in Remote mode; otherwise, the clips will not be transferred. You can switch the VTR from Local to Remote mode only on the VTR panel. If the Local box in the menu is enabled, the VTR is in Local mode. See [Controlling a VTR](#) on page 171.

The frame at the current position of the selected device is displayed in the image window. You can use the controls below the image window to play all the clips on the selected device. See [Viewing Captured and Assembled Material](#) on page 389.

- 12 Specify any VTR options in the Engineering menu. See [Setting Video Input and Output Engineering Menu Controls](#) on page 175.
- 13 Optional: Set the value in the Capture Handles field.
If Force Handles is enabled, clips will be recaptured if they do not contain at least as many handles as specified in the Capture Handles field. See [Capture Group](#) on page 352.
- 14 To capture all open EDLs that share the same library reel, enable Multiple EDLs.

NOTE If you already have one EDL loaded, and then load another EDL with the Same Library Reel option enabled, both EDLs will be captured on the same reel in the clip library as long as Multiple EDLs is enabled in the Capture menu.

- 15 Set any options for audio sources. See [Defining Audio Tracks to be Captured](#) on page 383.

16 Click Auto-Capture.

If a tape is not already loaded, you are prompted to insert one into the VTR. The options for capture appear.

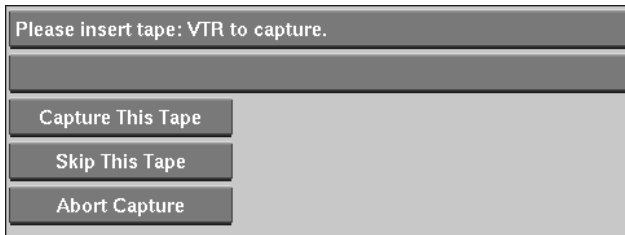

17 Click Capture This Tape to begin the auto-capture.

To minimize VTR transport, the clips are sorted according to their positions on the tape. Clips are always captured in C Mode, regardless of the display sort mode you selected.

18 When required, select a different tape to capture from in the Capture Order list.

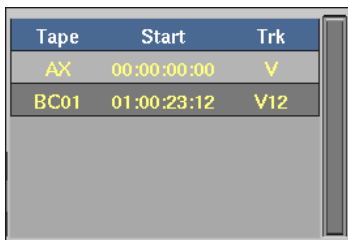

Tape	Start	Trk
AX	00:00:00:00	V
BC01	01:00:23:12	V12

You will need to repeat this for every tape that you are using during the auto-capture.

19 When the auto-capture is complete, click Exit Auto-Capture.

Each clip is named according to the event number or clip name comment, and is assigned in and out points set to the location used by the EDL at the time of capture. Tracks that are not used by the event are not assigned an output channel (denoted by "--").

20 Click Exit Import EDL.

The clips appear in the clip library on a reel specified in the Library Reel field.

Defining Audio Tracks to be Captured

You can define the number of audio tracks to be captured for all sources that have audio. By default, audio is captured for each event only as specified in the EDL. Using the All Audio option, you can capture more audio than is defined in the EDL. This is useful for EDLs that may have missing audio. If an event was mislabelled (on the audio side), you can modify the EDL to assemble other source track audio.

The All Audio button does not affect sources in the EDL that have no associated audio and it does not affect the EDL.

To define the number of audio tracks to be captured:

- 1 In the Auto-Capture menu, enable All Audio.

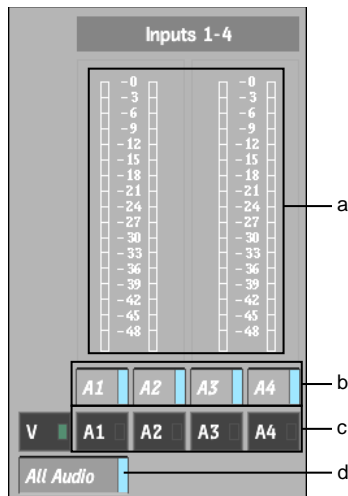

(a) Input Level meters (b) Enabled Audio Track buttons (c) Audio Track buttons (d) All Audio button

- 2 Enable the audio track buttons to define the number of audio tracks generated for all sources with audio. The first four audio tracks (A1 to A4) are captured by default.

Audio Track Patching

You can adjust the audio track patching for the capture session using the audio patch controls in the Engineering menu. Each audio channel has a separate control that contains the source channel and its mapped record channel. You can adjust the patching for up to eight audio channels. By default, audio channels A1-A8 on the source tapes map to audio channels A1-A8 in the captured clips.

To adjust audio patching for an EDL capture session:

- 1 In the Auto-Capture menu, click Engineering.

The Engineering menu appears.

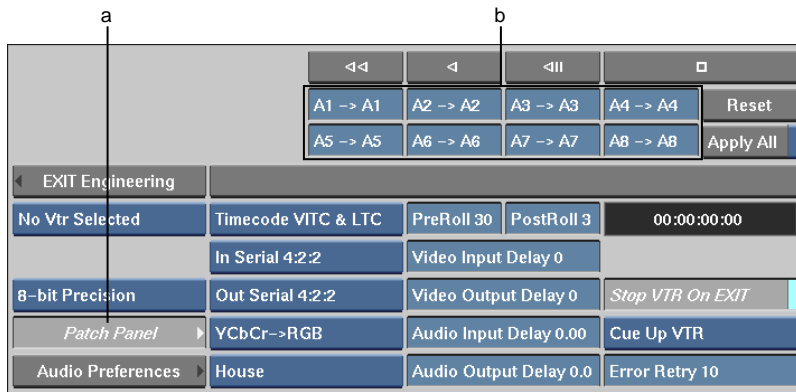

(a) Patch Panel button (b) Audio patch panel.

- 2 Click the Patch Panel button to display the audio patch panel.
- 3 Drag the audio field that corresponds to the channel that you want to patch.

The fields in the patch panel correspond to the recorded audio channels. Therefore, if you want to map source audio 3 & 4 to record audio 1 & 2, you set the first field (which corresponds to record A1) to A3->A1 and the second field (which corresponds to record A2) to A4->A2.

Importing Files Using an EDL

Use a file-based EDL to import (or soft import) files from a standard filesystem into Flame. These are usually OMF files, or EDLs that contain DLEDL flags in the event comments that reference the location and name of the files to import.

In the case of OMF files, this includes only audio media. Upon loading the OMF file into the EDL module, the embedded audio media is extracted from the OMF file and placed in a temporary location. Before assembling the EDL, you import the audio media references in the OMF file EDLs to create clips in the clip library.

To import files using a file-based EDL:

- 1 From the clip library, click Import EDL.
- 2 From the Import EDL menu, click Load.
The EDL Load menu appears.
- 3 Select the EDLs that you want to load.
- 4 Click Load.

The selected EDLs are loaded into the Import EDL module. The EDL contains events that point to the files on the filesystem. When you load a file-based EDL, Import is selected in the Capture/Import box.

- 5 Enter a name for the clip in the Name field.
- 6 Enter a library name in the Library Reel field.
- 7 In the EDL list, select the events that you want to import.

Do any of the following:

- To select a single event, click the event number entry. Click the event number entry of another event to unselect the first entry.
- To select a range of events, hold **Shift**, select an event, and click the last event in the range that you want to select. You can also click and drag to select a range of events.
- To add to a range of events, hold the **Ctrl** key or the pen button when you select an event.
- To select all events, use the Select All or Unselect All buttons.

NOTE When no event is selected, all events in the EDL are imported.

- Optional: If you need to soft-import the files, in the Preferences tab, enable Import As Soft Import to load the files.
Otherwise, the files are copied to the framestore.

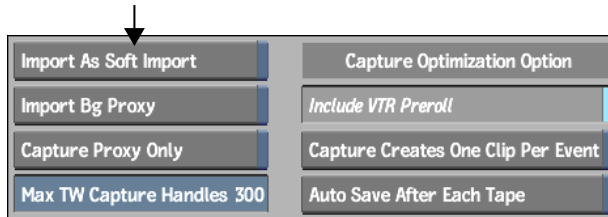

- Click Import.
The files are imported.

Assembling EDLs

Before assembling an EDL, make sure that you have auto-captured or imported the clips you want to use from the EDL. If you are assembling clips that have not been captured, they are replaced with either black frame elements or Unlink Media elements. See [Recapturing Media](#) on page 280.

Assembling a Single EDL

Once all the media is available on the system (for instance, after completing an auto-capture session and importing files) and the Assembly Options are set, you can assemble your EDL.

To assemble a single EDL:

- From the Import EDL menu, load the EDL that you want to assemble.
- Optional: Click Assembly Options and specify any assembly options that you want to use. See [Assembly Options Menu](#) on page 324.
- Enter the name for the assembled clip in the Name field.
- Specify the destination library reel.
- In the Assemble box, click Assemble.

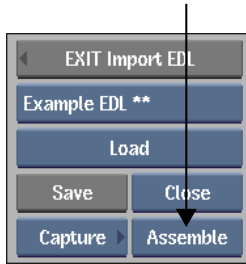

When the auto-assembly is complete, the assembled clip is saved in the specified clip library. The assembled clip is always the first clip on the reel.

You can use the Player to view the final assembled EDL result. See [Viewing Captured and Assembled Material](#) on page 389.

- 6 Click Exit EDL.

Assembling Multiple EDLs

If you have multiple EDLs, you can use Multi-assemble mode to combine all the EDLs into a multitrack. You can also use Multi-assemble mode to create a multilayer clip for vertical editing. When you multi-assemble EDLs, you select the EDLs in the order in which you want them to appear in the multitrack.

To multi-assemble clips:

- 1 In the Import EDL menu, load all the EDLs that you want to multi-assemble.
- 2 In the Assemble box, select and click M-Assemble.

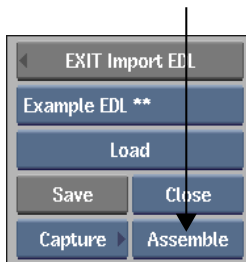

The Multi-Assemble menu appears.

- 3 Select EDLs in the order that you want them to appear in the multitrack by clicking the Track column.

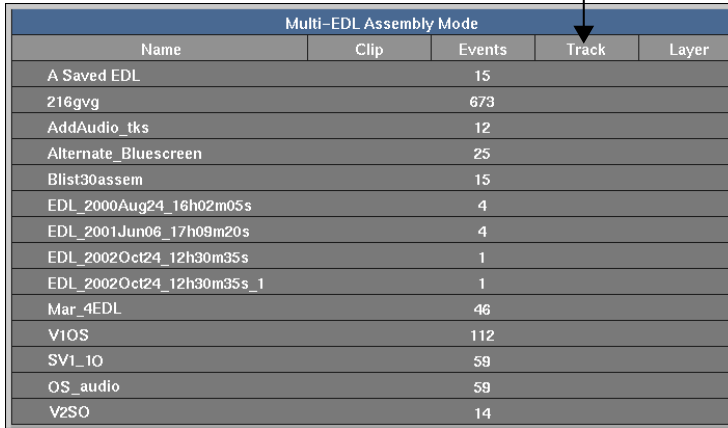

Multi-EDL Assembly Mode				
Name	Clip	Events	Track	Layer
A Saved EDL		15		
216gvg		673		
AddAudio_tks		12		
Alternate_Bluescreen		25		
Blist30assem		15		
EDL_2000Aug24_16h02m05s		4		
EDL_2001Jun06_17h09m20s		4		
EDL_2002Oct24_12h30m35s		1		
EDL_2002Oct24_12h30m35s_1		1		
Mar_4EDL		46		
V1OS		112		
SV1_1O		59		
OS_audio		59		
V2SO		14		

- 4 If you want to create a multilayer clip for vertical editing, you can change the layer assignment by clicking the Layer column.
You may need to deselect some entries, depending on the track to which you are trying to add additional layers.
- 5 Enter the name for the assembled clip in the Name field.
- 6 Specify the destination library reel.
- 7 Click Assemble Selected EDLs.
The assembled clip is created in the clip library.

Capturing and Assembling Multiple EDLs into Acts

You can assemble more than one EDL onto the same video layer to create acts. For instance, if you have a show that you have edited in three separate blocks (with three different EDLs), you can assemble these EDLs back into one clip. If the EDLs have overlapping timecode, you have to manually adjust the timecode; otherwise, when you assemble the EDLs, there will be missing material in the assembled clip.

To capture and assemble multiple EDLs into acts:

- 1 From the Import EDL menu, click Load.

The EDL Load menu appears.

- 2 From the EDL Load menu, enable Same Library Reel.
- 3 Select the EDLs that you want to load, and then click Load.
The selected EDLs are loaded into the Import EDL module.
- 4 Switch between the opened EDLs to make sure that there is no overlapping timecode between the EDLs.
If there is, adjust the timecode manually. See [Editing an EDL](#) on page 361.
- 5 Enter a name for the clip in the Name field.
- 6 Click Capture.
The Auto-capture menu appears.
- 7 Enable Multiple EDLs.
- 8 Click Auto Capture.
All the material is captured.
- 9 Click Exit Auto Capture to return to the Import EDL module.
- 10 From the Assemble box, select M-Assemble.
The Multi-Assemble menu appears.
- 11 Click the Track column for the first EDL, then **Ctrl**-click the Layer column for each of the other EDLs that you want to add to the same track.
Refer to the Track and Layer column to make sure that all EDLs will be assembled on the same tracks/layers. For example, if you want to add three EDLs to track V1, all three EDLs should all be assigned to track V1 and layer L1.
If you want to add other EDLs as acts on another video track, click the Track column for the first EDL in the set. Next, **Ctrl**-click the Layer column for the other EDLs you want to add to the same track.
- 12 Click Assemble Selected EDLs.
The selected EDLs are assembled onto the specified library reel.

Viewing Captured and Assembled Material

Use the EDL Player to view source clips of a captured and assembled EDL. You can assemble all or part of the clip with the EDL Player. You can also make a

record clip and view the final material in the EDL Player. You can then modify the EDL, make a new record clip, and view your changes in the EDL Player without having to exit the EDL module.

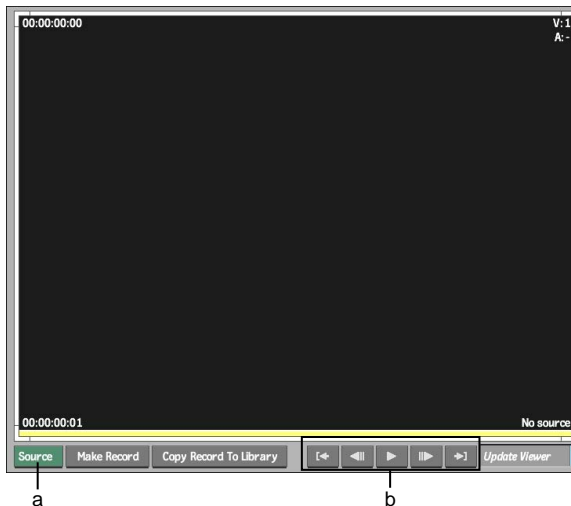

(a) Focus box (b) Player controls

To view captured material:

- 1 In the Import EDL menu, ensure that the Source option is selected in the Focus box.
- 2 Select an event in the EDL.
The first frame of the selected event appears in the EDL Player. You can also select the Source In or Record In entries in the EDL to do the same. Select the Source Out or Record Out entries in the EDL to display the last frame of the event in the EDL Player.
- 3 Use the EDL Player controls to view the clip.
- 4 To make a record of the current clip, click Make Record.
- 5 To copy the record clip to the library, click Copy Record To Library.

To view an assembled EDL:

- 1 Select the events that you want to assemble.
- 2 Click Make Record in the EDL Player.

A record clip is created and appears in the EDL Player.

- 3 Use the Player controls to view the clip.

You can modify the EDL and repeat these steps to view your changes. Once you have the result that you want, click the Copy Record To Library button to save the clip in the clip library.

Exporting EDLs

17

Topics in this chapter:

- [About Generating and Outputting EDLs](#) on page 393
- [About the Export EDL Menu](#) on page 394
- [Generating EDLs](#) on page 399
- [Outputting EDLs](#) on page 401

About Generating and Outputting EDLs

Use the Export EDL menu to save an EDL for any clips that you select in the clip library. When you save an EDL, you can use one of the following methods:

- Generate an EDL file and save it to the EDL directory.
- Output the EDL to a VTR using the Output options or as a clip in a clip library.

When you generate an EDL, you create an EDL from a clip in the clip library in any of the supported industry standard formats (such as CMX3600, Sony™ 9100, GVG). These files are made up of metadata only.

A clip may contain a number of audio tracks. However, this depends on the EDL format that you generate. When a format uses only two audio tracks, the other audio tracks are disabled.

In the process of outputting an EDL, you actually output the media used to build a clip to the clip library or to a VTR. This is useful for quickly dumping source clips onto a tape. You can also output an EDL in order to conform a program on another system to perform the final colour grading. In this case, after the colourist has completed work and created a new graded tape, you can recapture the graded material into a final colour-corrected clip using the output EDL.

About the Export EDL Menu

Use the Export EDL menu to save and export a clip as an EDL file or output a generated EDL to a VTR or clip library.

This menu consists of four main areas:

- Track table
- Clip list
- EDL Save Options group
- Output Options group

Additionally, there are a few important controls outside of these areas such as the Generate button and the Save Generated EDL button.

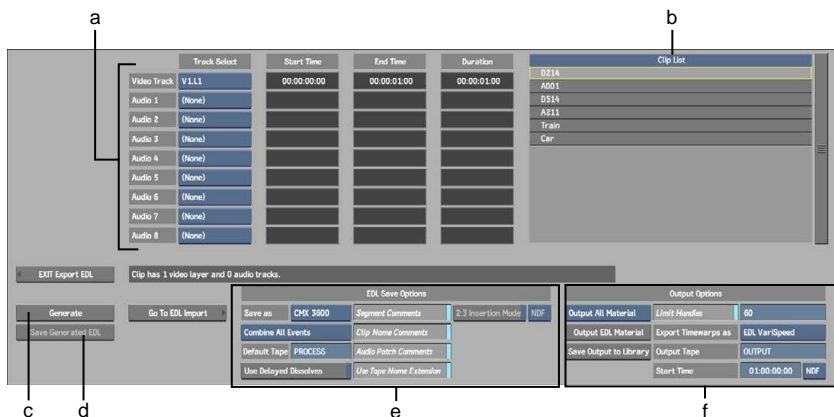

(a) Track table (b) Clip list (c) Generate button (d) Save Generated EDL button (e) EDL Save Options group (f) Output Options group

Generate button Generate the new EDL. This action activates the Save Generated EDL, Output EDL Material, and Save Output to Library buttons.

Save Generated EDL button Save the generated EDL as a file. Specify a file name and path for the saved EDL in the file browser that appears, and then click Save. Ensure that your file name does not contain any of the following characters: ` # ~ @ \$ % ^ & * () [] { } < > \ | / ! ? , ; : ' "

Track Table

The Track table shows the video and audio tracks that the EDL will be based on. The table is divided into five columns.

a

	Track Select	Start Time	End Time	Duration
Video Track	V1.L1	00:00:04:00	00:00:28:24	00:00:24:24
Audio 1	A1	00:00:04:00	00:00:27:01	00:00:23:01
Audio 2	A2	00:00:04:00	00:00:27:01	00:00:23:01
Audio 3	(None)			
Audio 4	(None)			
Audio 5	(None)			
Audio 6	(None)			
Audio 7	(None)			
Audio 8	(None)			

(a) Track Type column

Track Type The first row specifies the video track and the remaining rows refer to the audio tracks.

Track Select The selected track's name and number. Use this display to select the tracks that the EDL is based on.

Start Time The track's start timecode.

End Time The track's end timecode.

Duration The track's duration.

EDL Save Options Group

When you generate an EDL, you can change the EDL format, how matching events are combined, and the default tape number. You set the appropriate options in the EDL Save Options area of the Export EDL menu.

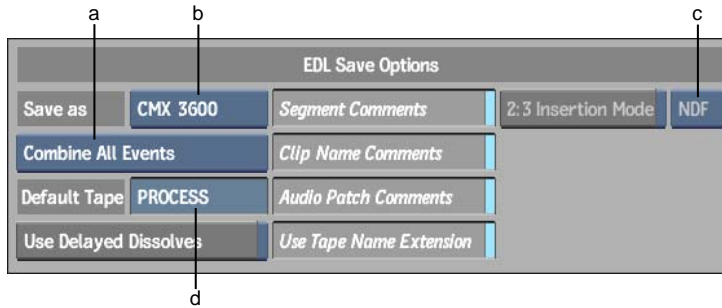

(a) EDL Event Combination box (b) EDL Format box (c) Frame Code Mode box
(d) Default Tape field

EDL Event Combination box Select an option to indicate how events with the same source timecodes, record timecodes, and tape ID are combined when the EDL is generated.

Select:	To use:
Combine All Events	A single entry for all video and audio events.
Combine Audio Events	One entry for audio events and a separate entry for video events.
Never Combine Events	A separate entry for each video and audio event.

EDL Format box Select the format of the generated EDL. You can save EDLs in any of the following formats:

- CMX 340
- CMX OMNI
- GVG 4 Plus (GVG v4.1 or higher)
- SONY 910
- SONY 9000
- SONY 9100
- CMX 3600
- GVG 4
- SONY 900
- SONY 5000
- SONY 9000 Plus (v2.21 or higher)

Segment Comments button Enable to allow comments added to the timeline to be included in the generated EDL.

Clip Name Comments button Enable to allow clip name comments to be included in the generated EDL.

2:3 Insertion Mode button Enable to convert the framerate of a 24p clip from 23.97 fps to 29.97 fps, and maintain 2:3 pulldown information for all in and out points (including cuts, wipes, dissolves, and timewarps). 2:3 pulldown data is important when master tapes are sent out for hardware-based tape-to-tape colour correction.

The EDL file will include explicit notification of hybrid splices as punctuation marks in the record in and out data.

A:	Indicates a:
period (.)	Regular splice record-in point for 29.97 fps non-drop frame timecode tapes.
comma (,)	Regular splice record-in point for 29.97 fps drop frame timecode tapes.
colon (:)	Hybrid splice record-in point for 29.97 fps non-drop frame timecode tapes.
semi-colon (;)	Hybrid splice record-in point for 29.97 fps drop frame timecode tapes.

This button is enabled by default when a 24p template is selected at project creation.

Frame Code Mode box Select the drop frame mode for the output material. Select DF (drop frame) or NDF (non-drop frame) format.

Use Delayed Dissolves button When enabled, delayed dissolves are included in the generated EDL.

Default Tape field Enter a tape name to override the default tape ID when saving an EDL. Source clips are assigned tape IDs when loaded using the Input Clip or Import EDL menu. For example, an edit that uses a clip created with the Colour Corrector does not have a tape ID. When the EDL is generated, the clip is given the tape ID in the Default Tape field.

Audio Patch Comments button Enable to allow clip audio patching comments to be included in the generated EDL.

Use Tape Name Extension button Enable to add a list to the end of the EDL that shows the relationship between the short tape name (8 characters, maximum) used in the EDL and the long tape name (52 characters, maximum) that you can set in the Import EDL menu.

Output Options Group

Before outputting an EDL, select the material that is output, the length of handles (if any), the method of exporting timewarps, the output tape ID, and the starting timecode.

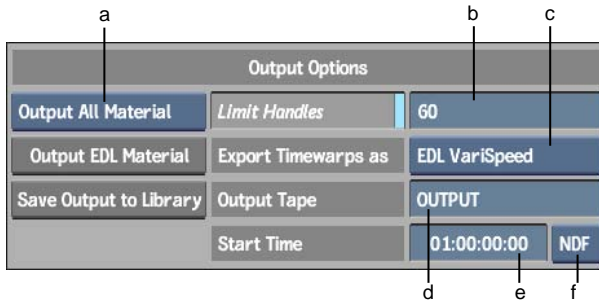

(a) Output Type box (b) Limit Handles field (c) Timewarp Mode box (d) Output Tape field (e) Start Timecode field (f) Frame Code Mode box

Output Type box Select the material to output to a VTR.

Select:	To:
Output All Material	Output all source clips and clips created in Flame.
Output Generated Only	Output only clips created in Flame.
No Output	Not output any clips. Only the EDL is generated.

Limit Handles button Enable to export the source clip with a specified maximum number of frames before and after.

Limit Handles field Enter a value for the number of frames used before and after the edit.

Timewarp Mode box Select how timewarps are output.

Select:	To:
EDL Varispeed	Create a timewarp command in the EDL that plays the clip at the timewarp speed.
Rendered Source	Render the timewarp before outputting the clip to the VTR. This creates a newly rendered clip and replaces the timewarp.

NOTE There is no standard EDL format that recognizes timewarps created using the Timewarp Editor. If you create a timewarp using a custom curve, you must use the Rendered Source option; otherwise, the timewarp curve is lost.

Output EDL Material button Output the EDL material to a VTR. The EDL Output module appears, which is comprised of the same controls as the Clip Output module.

Save Output to Library button Output the EDL material as a clip in the clip library. The EDL is output to the same library reel from which you originally accessed the Export EDL menu.

Output Tape field Enter a tape ID for the output material. The Output tape ID is used in the EDL to reference the destination of the material. Note that the edit's original tape ID is added to the Comment field. This is useful if you want to trace an element to its original source.

Start Timecode field Enter a value to specify the start timecode for the output material. If the start timecode is 01:00:00:00, the clip with all the material begins at 01:00:00:00. The start timecode is used in the EDL to reference the location of material.

Frame Code Mode box Select the drop frame mode for the output material. Select DF (drop frame) or NDF (non-drop frame) format.

Generating EDLs

You can generate an industry-standard EDL containing the metadata needed to recreate a clip that consists of one video track and up to eight audio tracks (depending on the EDL format). For clips that contain more than one video track or eight audio tracks, you must generate multiple EDLs.

In addition to source/record timecode for video and audio tracks, you can include clip name comments, audio patching information, and the reel name in the generated EDL. This information can be useful in helping to recreate a timeline clip on another system.

To generate and save an EDL:

- 1 In a clip library select the clips that you want to export.
- 2 Click Export EDL.

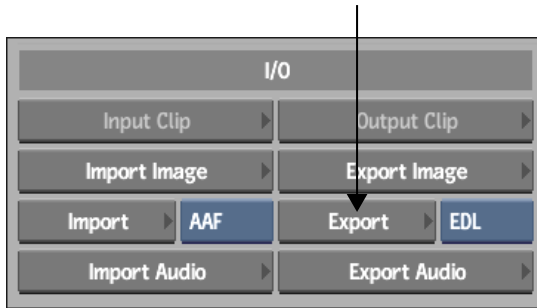

The Export EDL menu appears.

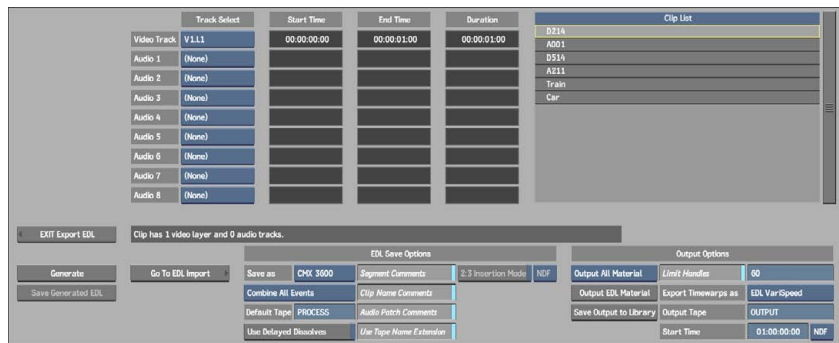

- 3 In the Clip list, select the clip that you want to export.
- 4 In the Track table, select video and audio tracks to include in the EDL.
- 5 Specify any EDL Save options. See [EDL Save Options Group](#) on page 395.
- 6 In the Output Options group, from the Output Type box, select No Output.
- 7 Click Generate.
The EDL is generated and the Save Generated EDL button becomes active.
- 8 Click Save Generated EDL.
The file browser appears.
- 9 Specify the location of the exported file and the file name, and then click Save.

Ensure that your file name does not contain any of the following characters: ` # ~ @ \$ % ^ & * () [] { } < > \ | / ! ? , ; : ' "

The EDL is exported to the specified location.

Outputting EDLs

You can output an EDL as a clip in the clip library or to a VTR. This is an alternate method of archiving a project that, along with an EDL, provides a backup mechanism for restoring both project metadata and media.

When you output a clip, the original start and end timecodes are added to the Comment field of the generated EDL along with the tape ID. This is useful if you want to trace the material referenced in the generated EDL to its location on the original source tape.

To output an EDL to a VTR or a clip library:

- 1 In the clip library, select the clips that you want to output.
- 2 Click Export EDL.

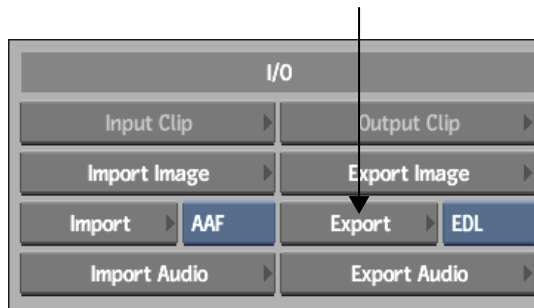

The Export EDL menu appears.

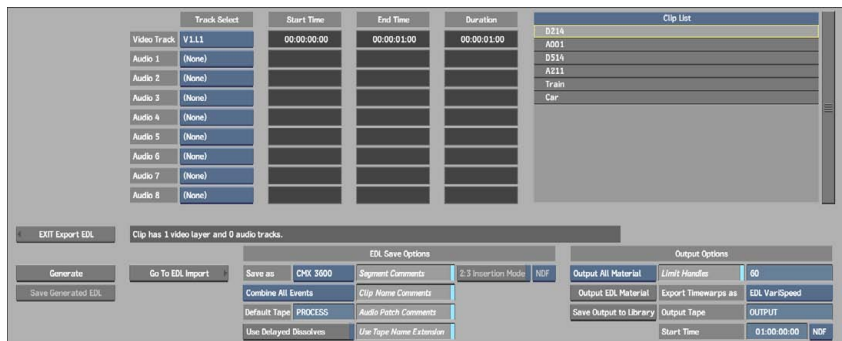

- 3 In the Clip list, select the clip that you want to export.
- 4 In the Track table, select tracks video and audio tracks to include in the EDL.

- 5 Specify any EDL Save options. See [EDL Save Options Group](#) on page 395.
- 6 In the Output Options group, from the Output Type box, select either Output All Material or Output Generated.
- 7 Specify any Output options. See [Output Options Group](#) on page 398.
- 8 Click Generate.
The EDL is generated and the Save Generated EDL, Output EDL Material, and Save Output to Library buttons become active.
- 9 Do one of the following:
 - Click the Output EDL Material button to output the EDL material to a VTR. The EDL Output module appears, which is comprised of the same controls as the Clip Output module.
 - Click the Save Output to Library button to output the EDL material as a clip in the clip library. The EDL is output to the same library reel from which you originally accessed the Export EDL menu.

Timecode and Keycode

18

Topics in this chapter:

- [About Timecode and Keycode](#) on page 403
- [Displaying Timecode and Keycode](#) on page 405
- [About the Timecode Calculator](#) on page 409
- [About the Keycode Calculator](#) on page 410
- [About the Change TC/KC/Rate Tools](#) on page 413
- [Changing Timecode](#) on page 418
- [Changing Keycode](#) on page 419
- [Copying Keycode](#) on page 421
- [Changing Frame Code Mode](#) on page 421
- [Manually Assigning Timecode and Keycode on Import](#) on page 423
- [Removing Conflicts Between Clips in Timecode or Keycode](#) on page 424
- [About the Burn In Menu](#) on page 425
- [Burning-in Clip Information](#) on page 428

About Timecode and Keycode

Timecode and keycode are essential tools for working with EDLs, or for conform and recapture. They are the identification markers by which your media is referenced in an EDL. Timecode and keycode can be imported with the media, assigned, changed, burned-in, or removed.

Timecode is a form of media metadata that labels individual frames of video or film. Timecode contains binary-coded-decimal hour, minute, second, and frame identification. Timecode is used in film, video, or audio material to provide a time reference for editing, synchronisation, and identification. The invention of timecode made modern videotape editing possible, and led to the creation of non-linear editing systems. Timecode is defined in the SMPTE 12M specification.

Keycode (also known as edge code) tracks frames of film from source reels through the post-production pipeline using code. Keycode is a variation of timecode designed to uniquely identify frames in filmstock. Keycode is a valuable tool for any project that originates on film, evolves through digital post production, and eventually references the original film material for final image capture. Keycode is printed on film in both a human-readable and machine-readable form. It indicates the manufacturer and film emulsion, a unique identification for each reel, as well as the footage and frame number.

Keycode appears in a varying number of increments along the film strip depending on the film gauge. For example, on 35 mm film, keycode appears every foot, which translates to every 16 frames of film.

Ways that Timecode and Keycode is Preserved or Destroyed

Depending on how you work with a clip, the timecode and keycode it contains can be either preserved or destroyed.

Timecode and keycode data is preserved in the following circumstances:

- When you edit clips in the timeline.
- When you commit or merge layers in the timeline for a clip from a single source.
- When you commit or merge layers in the timeline for a single-frame virtual clip.
- When you load a single clip into a module and then process, the timecode and keycode is preserved in the result clip.
- When you load multiple clips into a module and then process, the timecode and keycode contained in the back clip is preserved in the result clip.
- When you export or publish a source in the DPX format.

Timecode and keycode data is destroyed in the following circumstances:

- When you load multiple clips into a module, the result clip inherits the timecode and keycode of the back clip. Timecode and keycode for clips other than the back clip is destroyed.
- When you load a clip into Batch, its keycode is disregarded. Any results processed from Batch do not have keycode.

NOTE In Batch, you can use the Burn-In Timecode node to burn-in timecode and keycode. See [Burning-in Clip Information](#) on page 428.

- When you edit a clip and export as a DPX file.

TIP If you are using Clip History, you can retrieve timecode and keycode data from the original source clips.

Displaying Timecode and Keycode

Timecode and keycode can be displayed and monitored in the following user interface areas:

- Clip proxies
- Player
- Clip information overlay
- Timeline
- List View

When ranges of timecode or keycode are displayed, for example, in a Timeline or List view, the range is inclusive. The out value shows the timecode or keycode for the last frame of the element.

Displaying Timecode and Keycode on Clip Proxies

Keycode can be displayed on clip proxies on the desktop and in the clip library.

Timecode and keycode are displayed in clips as follows.

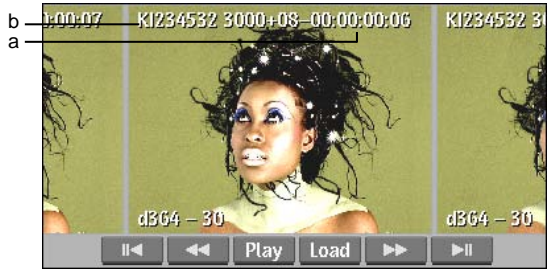

(a) Timecode for the current frame (b) Keycode for the current frame
Image courtesy of The House

To display timecode and keycode on proxies in the clip library:

- 1 In the clip library, ensure that View Mode is set to Proxies.

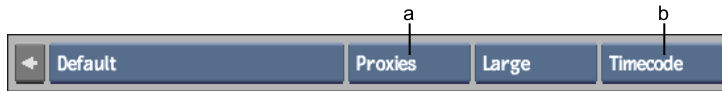

(a) View Mode box (b) Information box

- 2 From the Information box, select any option except No Display.

To display timecode and keycode on proxies on the desktop:

- 1 On the desktop, click Preferences.
- 2 In the Preferences menu, click the Desktop tab.
- 3 In the Clips group, from the Frame ID box, select an option that includes framecode/keycode.

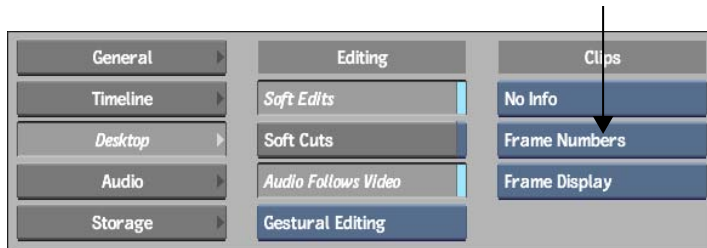

Select:	To display:
KC and Rec TC	Keycode and Record Timecode.

Select:	To display:
Src and Rec TC	Source Timecode and Record Timecode.
Record Time-Code	Record Timecode only.
Keycode	Keycode only.
Source Time-Code	Source Timecode only.

These settings are applied to the proxies on the desktop.

Displaying Timecode and Keycode in the Player

You can see the keycode and timecode of a source clip in the Player.



(a) Keycode Display field in the Player (b) Timecode Display field in the Player

To display timecode in the Player:

- 1 In the Player, from the Clip Information box, select either Source or Record to display the start and end timecode.



Select:	To display:
Source	The start and end source keycode only.
Record	The start and end record timecode only.

Displaying Timecode and Keycode in the Clip Information Overlay

You can see the timecode and keycode of a source clip by ALT-clicking it on the Desktop.

Timecode and keycode are displayed in the clip information overlay as follows.



(a) Start keycode for the clip (b) Start Source Timecode for the clip (c) Start Record Timecode for the clip (d) End Record Timecode for the clip (e) End Source Timecode for the clip (f) End keycode for the clip

Image courtesy of The House

Displaying Timecode and Keycode in the Timeline

To display the timecode and keycode data for each timeline segment of a clip, expand the timeline segment.

Timecode and keycode is displayed in the timeline as follows.

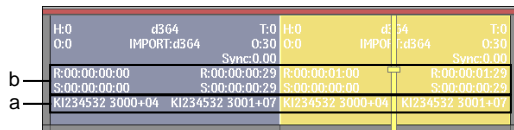

(a) Keycode (b) Timecode

Displaying Timecode and Keycode in the List View

You can see timecode and keycode data in the List View of the file browser for source clips.

Set	Location	Clip Name	TC In	TC Out	Duration	Frames	KC In	KC Out	Type	V	A	Width	Height	Bit	SH	P	U	E	Created	Archived	
		K-REC-191	00:00:00+00	00:00:00+00	13	13	KI120863 7638+07	KI120863 7638+07	IMPORT	1	0	1024	778	10	P	V			1	2004/12/03	
		REC-19113	00:12:44+13	00:12:44+13	1	1	KI120863 7637+12	KI120863 7638+04	IMPORT	1	0	1024	778	10	P	V			1	08:22	
		19113	00:12:44+13	00:12:44+13	1	1	KI120863 7637+12	KI120863 7637+12	IMPORT	1	0	1024	778	12	P	V			1	2004/12/03	
		19114	00:12:44+14	00:12:44+14	1	1	KI120863 7637+13	KI120863 7637+13	IMPORT	1	0	1024	778	12	P	V			1	2004/12/03	
		19115	00:12:44+15	00:12:44+15	1	1	KI120863 7637+14	KI120863 7637+14	IMPORT	1	0	1024	778	12	P	V			1	2004/12/03	
		19116	00:12:44+16	00:12:44+16	1	1	KI120863 7637+15	KI120863 7637+15	IMPORT	1	0	1024	778	12	P	V			1	2004/12/03	
		19117	00:12:44+17	00:12:44+17	1	1	KI120863 7638+00	KI120863 7638+00	IMPORT	1	0	1024	778	12	P	V			1	2004/12/03	
		19118	00:12:44+18	00:12:44+18	1	1	KI120863 7638+01	KI120863 7638+01	IMPORT	1	0	1024	778	12	P	V			1	2004/12/03	
		19119	00:12:44+19	00:12:44+19	1	1	KI120863 7638+02	KI120863 7638+02	IMPORT	1	0	1024	778	12	P	V			1	2004/12/03	
		19120	00:12:44+20	00:12:44+20	1	1	KI120863 7638+03	KI120863 7638+03	IMPORT	1	0	1024	778	12	P	V			1	2004/12/03	
		19121	00:12:44+21	00:12:44+21	1	1	KI120863 7638+04	KI120863 7638+04	IMPORT	1	0	1024	778	12	P	V			1	2004/12/03	
		19122	00:12:44+22	00:12:44+22	1	1	KI120863 7638+05	KI120863 7638+05	IMPORT	1	0	1024	778	12	P	V			1	2004/12/03	
		19123	00:12:44+23	00:12:44+23	1	1	KI120863 7638+06	KI120863 7638+06	IMPORT	1	0	1024	778	12	P	V			1	2004/12/03	
		19125	00:12:45+00	00:12:45+00	1	1	KI120863 7638+08	KI120863 7638+08	IMPORT	1	0	1024	778	12	P	V			1	2004/12/03	
		19113	00:12:44+13	00:12:45+01	13	13	KI120863 7637+12	KI120863 7638+04	IMPORT	1	0	1024	778	10	P	V			1	2004/12/03	
		19113	00:12:44+13	00:12:45+01	13	13	KI120863 7637+12	KI120863 7638+08	IMPORT	1	0	1024	778	10	P	V			1	2004/12/03	
		19113	00:12:44+13	00:12:45+01	13	13	KI120863 7637+12	KI120863 7638+00	IMPORT	1	0	1024	778	10	P	V			1	2004/12/03	
		K-REC-1911	00:12:44+13	00:12:45+01	13	26	KI120863 7637+12	KI120863 7638+00	IMPORT	1	0	1024	778	10	P	V			1	08:27	
		REC-19113	00:12:44+13	00:12:45+01	13	26	KI120863 7637+12	KI120863 7638+00	IMPORT	1	0	1024	778	10	P	V			1	08:21	
		reed003_cjh	01:22:05+21	01:22:06+14	18	18	KI000120 0004+04	KI000120 0004+21	IMPORT	1	0	2048	1556	10	P	V			1	2004/12/03	

(a) Timecode In column (b) Timecode Out column (c) Keycode In column (d) Keycode Out column

About the Timecode Calculator

You can use the numeric keypad to work with timecode. When you click a timecode field, the numeric keypad appears with the full timecode.

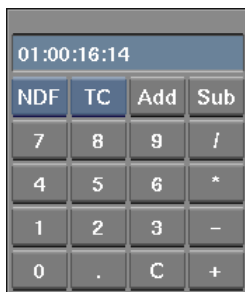

Use the numeric keypad to do the following:

- Go to the frame with a specific timecode.
- Calculate timecode from frame counts, and vice versa.
- Switch between drop and non-drop timecode (NTSC only).

- Convert drop timecode to non-drop timecode, and vice versa (NTSC only).

When you use the numeric keypad as a timecode calculator, some keys have a different function.

Click:	To:
Period	Insert two zeros.
TC/FRM	Switch, or show conversion, between frames and timecode.
DF/NDF	Switch between Drop Frame mode and Non-Drop Frame mode. If you are in PAL video, this button does not appear.

About the Keycode Calculator

When typing keycode values directly into the Keycode field, you use the keycode calculator.

You can select the film manufacturer and emulsion in the keycode calculator to determine the first two values of the keycode.

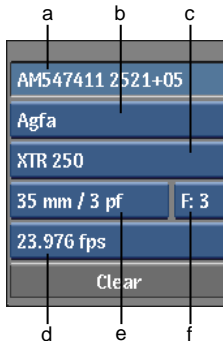

- (a) Keycode field (b) Film Manufacturer box (c) Film Emulsion box (d) Framerate box (e) Film Gauge box (f) Reference Foot box

Keycode field Indicates the keycode value for a frame or for the first frame of a sequence. Click to enter a new keycode value. Subsequent frames are assigned a keycode value incremented from this value in relation to the settings in the Film Gauge box, and optionally, the Reference Foot box when using 3-perf 35 mm film.

NOTE Although you can enter any two letters in the Keycode field to begin a keycode value, only those corresponding to an actual manufacturer and film emulsion populate the Film Manufacturer and Film Emulsion fields.

Film Manufacturer box Select the manufacturer of a source film reel. If you type a value in the Keycode field, the corresponding manufacturer is automatically selected in this box: the first letter of the keycode value indicates the manufacturer.

Film Emulsion box Select the emulsion of a source film reel. If you type a value in the Keycode field, the corresponding manufacturer is automatically selected in this box: the second letter of the keycode value indicates the film's emulsion. Only the film emulsions that correspond to the film manufacturer selected in the Film Manufacturer field appear.

Framerate box Select the framerate used when importing files that retain keycode. This value should be set at the framerate at which the film was transferred to video.

Film Gauge box Select the type of source film from which the frames originated. This is used to assign keycode to a sequence of frames starting with the value entered in the Keycode field.

Reference Foot box Select the reference foot for 35 mm / 3 perf film. Reference Foot is only active when Film Gauge is set to 35 mm / 3 perf. This number is necessary because 3-perf 35 mm film has a different number of frames in each foot of a 3-foot repeating sequence.

Keycode Syntax

Keycode in Autodesk Visual Effects and Finishing applications uses the following syntax:

KQ123456 7890+12

Where:

- K is the film manufacturer.
- Q is the film emulsion.
- 123456 (6 digits) is the film reel unique identifier.
- 7890 (4 digits) is the footage number.
- 12 (2 digits) is the frame number.

In 35mm / 3 perf keycode, a reference foot value is also set. The value can be 1, 2, or 3 between parenthesis:

KQ123456 1234+00(1)

Supported Film Emulsions

The available film emulsions are supported in keycode in Autodesk Visual Effects and Finishing applications as follows.

Kodak

- 5274/7274 Vision 200T
- 5277/7277 Vision 320T
- 5231/7231
- 5620/7620 Primetime 640T
- 5600/7600 Primetime
- 5294/7294
- SFX 200T
- 5249/7249
- 5295/7295
- 5287/7287 EXR Ultra Lat
- 5292/7292
- 5222/7222
- 5244/7244
- 5248/7248
- 5234/7234
- 5279/7279 Vision 500T
- 5293/7293
- 5297/7297
- 5298/7298
- 5245/7245
- 5247/7247
- 5272/7272
- 5296/7296
- 5243/7243
- 5289/7289 Vision 800T
- 5246/7246 Vision 250D

Fuji

- VELVIA col rev 8540
- F-64D/125/250D/500
- FCI

Eastman

- 5242/7242 Vision Color I
- 5299/7299 Vision2 HD
- 7265 PLUS-X
- 5205/7205 Vision2 250D
- 5218/7218 Vision2 500T
- 5229/7229 Vision2 Exp 500T
- 5212/7212 Vision2 100T
- 5284/7284 Vision Exp 500T
- 5285/7285 Ektachrome 100D
- 5217/7217 Vision2 200T
- 5263/7263 Vision 500T
- 7266 TRI-X
- 5201/7201 Vision2 50D

Agfa

- XTS 400
- XT 100
- XTR 250
- XT 320

Supported Film Gauges

The following film gauges are supported in keycode for Autodesk Visual Effects and Finishing applications:

- 16 mm and Super 16 mm / 1 perf
- 35mm / 3 perf
- 35mm / 4 perf
- 65mm / 5 perf

The increment offset of a particular frame from the keycode dot (which indicates the zero offset point on the film) can be recorded in one of two modes: frame offset and perforation offset. In general, film scanners can write keycode in either of these two modes.

For 35 mm / 3 perf and 35 mm / 4 perf film, both frame and perforation offset keycode are supported when importing files. For all other gauges, only frame offset mode is supported. In these latter cases, set the telecine to use frame offset keycode when you are scanning.

About the Change TC/KC/Rate Tools

The tools used to change timecode, keycode, or frame code mode are accessible in a number of ways from your Autodesk Visual Effects and Finishing application for your convenience. For this reason, the menus may look slightly different, but the functionality remains the same.

The Change Timecode Tool

The Change Timecode tool can be accessed as follows:

- In the clip library, from the Tools box, via the Change TC/KC option, when you select Timecode.

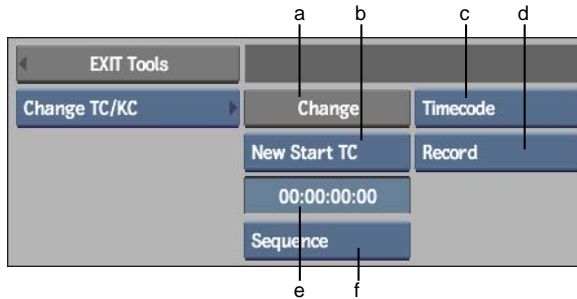

- From the Format menu, via the Change TC/KC/Rate option, when you select Timecode.

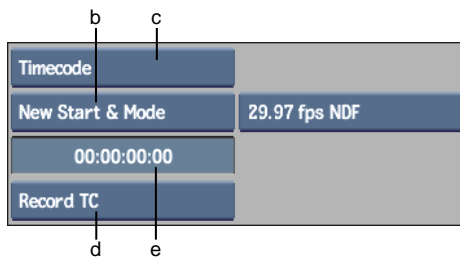

- (a) Change button (b) Change option box (c) Timecode/Keycode/Mode box (d) Change Target box (e) Start Timecode field (f) Timecode option box

The Change Timecode tool options are described as follows.

Change button Click to confirm values entered and apply them to the selected clip.

Change option box Select whether the start timecode and frame code mode will change.

Select:	To:
New Start & Mode	Change the start timecode and frame code mode (framerate and drop frame mode).
New TC Mode	Change only the frame code mode (framerate and drop frame mode).
New Start TC	Change only the start timecode.

Timecode/Keycode/Mode box Select whether timecode, keycode, or frame code mode will be changed.

Change Target box Select whether the source timecode, record timecode, or both source and record timecode will change.

Start Timecode field Enter the start timecode of a single selected clip or the first clip in a multi-clip selection.

Timecode option box Select the timecode relationship between multiple selected clips. The Timecode option box is enabled only for Change TC/KC when the Change option box is set to New Start & Mode or New Start TC.

Select:	To:
Step	Step the start timecode of multiple selected clips by the duration specified in the Step Timecode field.
Same TC	Assign the same start timecode to all clips.
Sequence	Assign a start timecode sequentially to each clip so that the clips follow each other immediately but do not overlap.

The Change Keycode Tool

The Change Keycode tool can be accessed as follows:

- In the clip library, from the Tools box, via the Change TC/KC option, when you select Keycode.

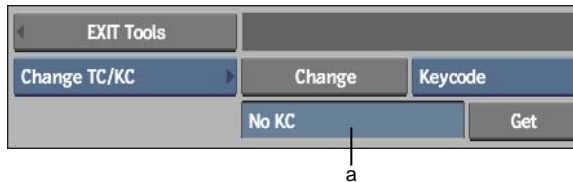

- From the Format menu, via the Change TC/KC/Rate option, when you select Keycode.

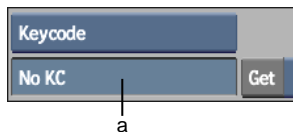

(a) Keycode field

The Change Keycode tool options are described as follows. Only those options that are unique to Keycode and not already described for Timecode are included here.

Keycode field Enter the start keycode of a single selected clip or the first clip in a multi-clip selection.

Get button Click and then select a clip to load the Keycode of that clip.

The Change Frame Code Mode Tool

The Change Frame Code Mode tool allows you to change the framerate and drop frame mode. The Change Frame Code Mode tool can be accessed as follows:

- In the clip library, from the Tools box, via the Change TC/KC option, when you select Timecode and New TC Mode (or New Start & Mode).

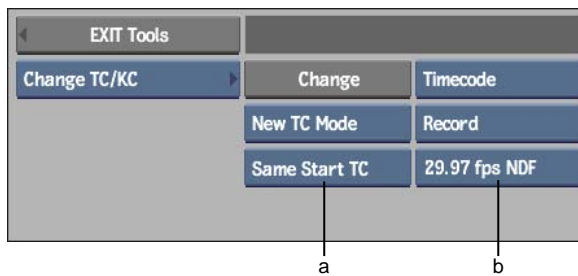

- From the Format menu, via the Change TC/KC/Rate option, when you select Rate.

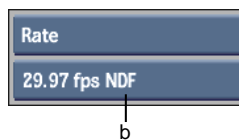

- From the Format menu, via the Change TC/KC/Rate option, when you select Timecode and then New TC Mode (or New Start & Mode).

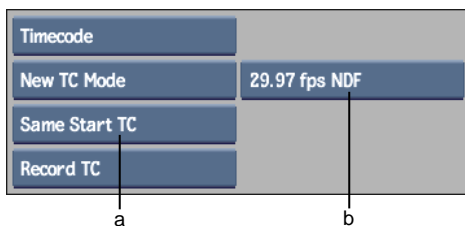

(a) Same Start TC/Frame box (b) Frame Code Mode box

The Change Frame Code Mode tool options are described as follows. Only those options that are unique to Frame Code Mode and not already described for Timecode are included here.

Same Start TC/Frame box Select a start option. The Same Start TC/Frame box is active only when New TC Mode is enabled.

Select:	To:
Same Start TC	Start with the timecode that matches the corresponding timecode in the new mode—calculated by the number of frames that correspond to the original timecode, starting from 00:00:00.
Same Start Frame	Start with the same timecode as the one used in the old mode.

Frame Code Mode box Select the framerate and drop frame mode for the selected clips. The Frame Code Mode box is enabled only when the Change option box is set to New Start & Mode or New TC Mode.

Select:	To apply:	TC Format:
23.976 fps	23.976 frames per second timecode. This frame rate is used for NTSC DVD playback.	00:00:00+00
24 fps	24 frames per second timecode. Used to transfer a video signal to film.	00:00:00+00
25 fps	25 frames per second timecode. Good for LCD monitors or display formats that are not interlaced.	00:00:00:00
29.97 fps NDF	29.97 frames per second Non-Drop Frame timecode (frame rate for colour NTSC). If you use 29.97 fps NDF, its indicated timings will not accurately correspond with real time.	00:00:00:00

Select:	To apply:	TC Format:
29.97 fps DF	29.97 frames per second Drop-Frame timecode (frame rate for colour NTSC). This times the video accurately with real time by dropping the extra frames in the count.	00:00:00:00
30 fps	30 frames per second timecode. Mimics a film camera's frame-by-frame image capture.	00:00:00:00
50 fps	50 frames per second timecode. Standard for PAL.	00:00:00:00
59.94 fps NDF	59.94 frames per second, Non-Drop Frame timecode (standard rate for NTSC). If you use 59.94 fps NDF, its indicated timings will not accurately correspond with real time.	00:00:00:00
59.94 fps DF	59.94 frames per second, Drop-Frame timecode (standard rate for NTSC). This times the video accurately with real time by dropping the extra frames in the count.	00:00:00:00
60 fps	60 frames per second timecode. Used for NTSC video.	00:00:00:00

NOTE If you change the frame code mode of a clip, timewarps will automatically be applied to the audio or video tracks to maintain the audio and video sync.

Changing Timecode

You can change the start timecode of a clip for the record timecode, source timecode, or both.

If you are mixing clips that originate from formats that use different timecode, you may want to change their timecode. Use the Change Timecode tool to change the start timecode for a clip and manage source clips with different timecode formats.

To change the timecode of a clip:

- 1 Access the Change Timecode tool in one of the following ways:
 - From the Format menu, select Change TC/KC/Rate, and then click Timecode.

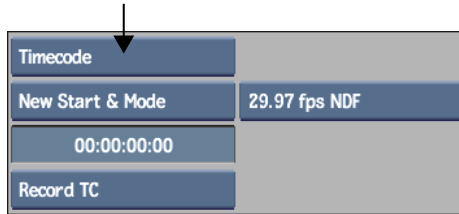

- In the Clip Library, click Tools, and then from the Tools box, select Change TC/KC, and click Timecode.

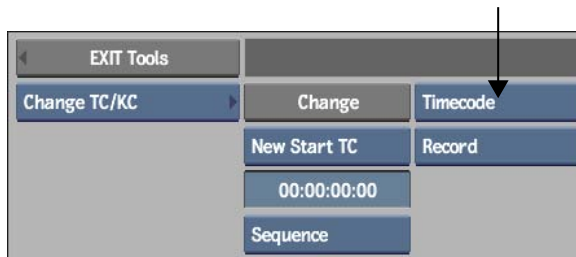

- 2 In the Timecode field, enter the timecode value that you want to apply to the frames of a clip.
- 3 Select other timecode options, such as applying to source, record, or both. See [The Change Timecode Tool](#) on page 413.
- 4 Do one of the following:
 - Click a clip to which you want to apply the timecode value. The value is incremented for each frame of the clip according to the values you set. If you are applying timecode to a clip on the desktop and you select any frame, the timecode value you entered is applied to the frame and is incremented positively forward and negatively backward for the rest of the frames of the clip.
 - If you are using the Change TC/KC tool, select the clip to which you want to apply timecode, and then click Change.

Changing Keycode

You can change or add keycode to a sequence. You might do this, for example, if the keycode data was corrupted when written by the telecine, or if you

entered wrong keycode values when using a third-party application to write keycode to an exported sequence.

NOTE You cannot apply keycode to audio files.

To change the keycode of a clip:

- 1 Access the Change Keycode tool in one of the following ways:
 - From the Format menu, select Change TC/KC/Rate, and then click Keycode.

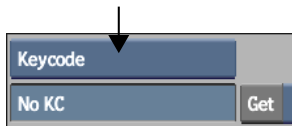

- In the Clip Library, click Tools, and then from the Tools box, select Change TC/KC, and click Keycode.



- 2 In the Keycode field, enter the keycode value that you want to apply to the frames of a clip.
Ensure that you enter a keycode value according to the proper syntax. See [Keycode Syntax](#) on page 411.
- 3 Optional: To load the keycode of another clip, click the Get button next to the Keycode field, and select the clip.
The keycode value of the current frame of the selected clip is loaded into the Keycode field. You can then edit this value with the keycode calculator, or apply this keycode to other clips by selecting them.
- 4 Do one of the following:
 - Click a clip to which you want to apply the keycode value.
The value is incremented for each frame of the clip according to the values you set. If you are applying keycode to a clip on the desktop and you select any frame, the keycode value you entered is applied to the frame and is incremented positively forward and negatively backward for the rest of the frames of the clip.

- If you are using the Change TC/KC tool, select the clip to which you want to apply keycode, and then click Change.

Copying Keycode

You can copy keycode from one clip to another using the Copy tool.

To copy keycode from one clip to another:

- 1 From the desktop, click Copy.
- 2 From the Copy Mode box, select Keycode.

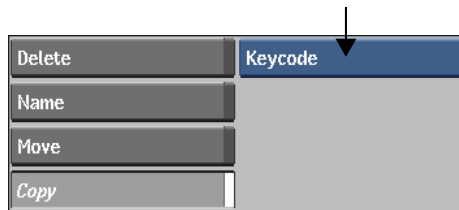

- 3 With the red arrow cursor, select the clip with the keycode that you want to copy.
- 4 With the white arrow cursor, select the clip to which you want to copy the keycode.

The keycode is copied to the clip.

NOTE Keycode data is always applied starting from the first frame of the clip, regardless of which frame you select.

Changing Frame Code Mode

The Frame Code Mode tool allows you to select the framerate and drop frame mode for your clip. You can convert the framerate and drop frame mode on the video and the audio clip. However, when you convert a clip's rate, its playback speed can be affected (both video and audio).

Also, if you change the frame code mode of a clip, timewarps will automatically be applied to the audio or video tracks to maintain the audio and video sync.

To change the frame code mode of a clip:

- 1 Access the Change Timecode tool in one of the following ways:
 - From the Format menu, select Change TC/KC/Rate, and then click Rate.

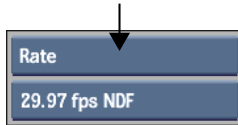

- From the Format menu, select Change TC/KC/Rate, then select Timecode and then click New TC Mode (or New Start & Mode).

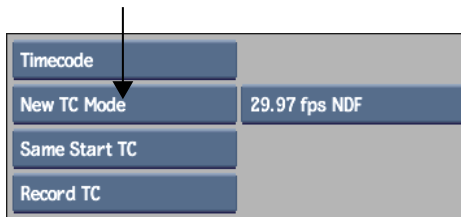

- In the Clip Library, click Tools, then from the Tools box, select Change TC/KC, select Timecode, and then click New TC Mode (or New Start & Mode).

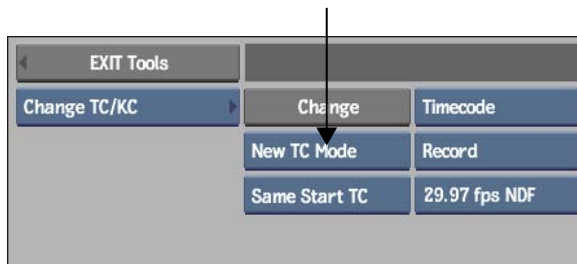

- 2 Select the desired framerate, drop frame mode, and start option. See [The Change Frame Code Mode Tool](#) on page 416.
- 3 Do one of the following:
 - Click a clip to which you want to apply the frame code mode value.
 - If you are using the Change TC/KC tool, select the clip to which you want to apply the frame code mode, and then click Change.

Manually Assigning Timecode and Keycode on Import

When importing sequences composed of any type of image file format, you can manually set the timecode, keycode, and frame code mode for the resulting clip. By setting keycode you also set the film gauge used for the clip. The film gauge defines how the keycode data is calculated.

To manually assign timecode and keycode data to image files on import:

- 1 Follow the general procedure for importing an image file, and stop at the point where you adjust Clip Metadata properties. See [Importing and Soft-Importing Image Files](#) on page 210.
- 2 From the Timecode box, select Enter Timecode.



Clip Metadata		
Enter Tape	Enter Timecode	Enter Keycode
IMPORT	Start 00:00:00:00	KB501776 4321+12
Up 1 level	29.97 NDF	35 mm / 4 perf
Name:	Scan First File	

Any embedded timecode data is ignored and replaced with the value that you enter directly in the Timecode field.

- 3 In the Timecode field, enter a Timecode value using the timecode calculator. See [About the Timecode Calculator](#) on page 409.



Clip Metadata		
Enter Tape	Enter Timecode	Enter Keycode
IMPORT	Start 00:00:00:00	KB501776 4321+12
Up 1 level	29.97 NDF	35 mm / 4 perf
Name:	Scan First File	

After entering a timecode value and closing the timecode calculator, the value appears in the Timecode field.

- 4 From the Keycode box, select Enter Keycode.

Clip Metadata		
Enter Tape	Enter Timecode	Enter Keycode
IMPORT	Start 00:00:00:00	KB501776 4321+12
Up 1 level	29.97 NDF	35 mm / 4 perf
Name:	Scan First File	

Any embedded keycode data is ignored and replaced with the value that you enter directly in the Keycode field.

- 5 In the Keycode field, enter a valid keycode value using the keycode calculator. See [About the Keycode Calculator](#) on page 410.

Clip Metadata		
Enter Tape	Enter Timecode	Enter Keycode
IMPORT	Start 00:00:00:00	KB501776 4321+12
Up 1 level	29.97 NDF	35 mm / 4 perf
Name:	Scan First File	

After entering a keycode value and closing the keycode calculator, the value appears in the Keycode field. As well, the film gauge that you set in the keycode calculator is inherited by the Film Gauge box in the Image Import menu.

TIP If you want to change the film gauge, including the reference foot for 35 mm / 3 perf film, you have to access the keycode calculator again by clicking the Keycode field.

- 6 Continue the procedure for importing an image file.
Your new timecode and keycode values are set.

Removing Conflicts Between Clips in Timecode or Keycode

When outputting a reel of clips in a single pass, you may need to change the timecode or keycode of the clips so they do not overlap. If your timecode or

keycode overlap when you attempt to output a reel of clips, you will receive an error message.

To remove conflicts in timecode between clips:

- 1 In the clip library, select a single clip or press **Ctrl** and select multiple clips.

NOTE Clips are sequential, based on the order of selection in the clip library.

- 2 From the Tools menu, select Change TC/KC.
- 3 From the Change option box, select New Start & Mode.
- 4 In the Change Target box, specify whether you are modifying the source timecode, the record timecode, or both. See [The Change Timecode Tool](#) on page 413.
- 5 In the Start Timecode field, enter the start timecode for the first clip.
- 6 From the Timecode option box, select Sequence.
This ensures that clip timecode does not overlap.
- 7 Click Change and confirm the operation.
Timecode is changed accordingly.

About the Burn In Menu

Use the Burn In menu to burn-in clip information such as keycode, timecode, date, and frame numbers.

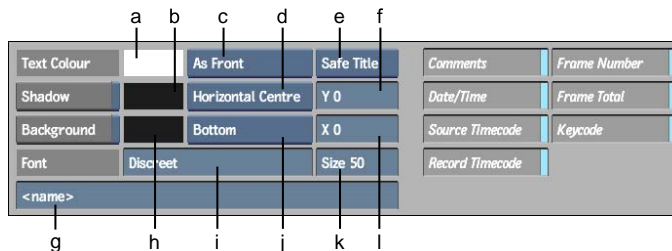

(a) Text Colour pot (b) Shadow Colour pot (c) Scan Format box (d) Horizontal Position box (e) Offset box (f) Horizontal Position field (g) Name field (h) Background Colour pot (i) Font box (j) Vertical Position box (k) Size field (l) Vertical Position field

Use the Burn-In Timecode menu in Batch to burn-in clip information such as keycode, timecode, date, and frame numbers.

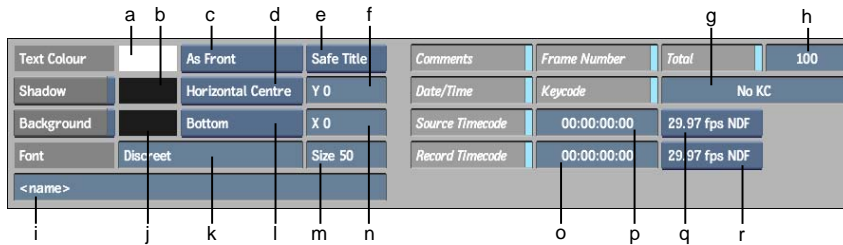

(a) Text Colour pot (b) Shadow Colour pot (c) Scan Format box (d) Horizontal Position box (e) Offset box (f) Horizontal Position field (g) Keycode field (h) Total Frames field (i) Name field (j) Background Colour pot (k) Font box (l) Vertical Position box (m) Size field (n) Vertical Position field (o) Source TC field (p) Record TC field (q) Source TC Frame Mode box (r) Record TC Frame Mode box

Shadow button Enable if you want the burned-in information to have a drop shadow. To change the colour of the shadow, use the Shadow Colour pot.

Text Colour pot Click to display the colour palette and select a text colour.

Shadow Colour pot Click to display the colour palette and select a shadow colour.

Scan Format box Select the scan format.

Select:	To:
Interlaced	Scan a frame-based clip with interlacing.
Progressive	Scan a frame-based clip with no interlacing.
As Front	Use the Scan format used on the front clip.

Horizontal Position box Select a horizontal position.

Select:	To position:
Horizontal Center	The burned-in text in the horizontal centre.
Right	The burned-in text to the right of the frame.
Left	The burned-in text to the left of the frame.

Offset box Select the appropriate offset option to account for the Safe Action or Safe Title area. This option only functions when the position is set

using the Horizontal and Vertical Position boxes, and not when using the Position fields.

Select:	To orient:
Full	The burned-in text within the full frame.
Safe Action	The burned-in text within the safe action area.
Safe Title	The burned-in text within the safe title area.

Horizontal Position field Drag left or right, or click to enter a horizontal position value that offsets the selected option in the Offset box.

Comments button Enable to burn-in a comment that you specify in the Name field.

Date/Time button Enable to burn-in date and time.

Source TC button Enable to burn-in the source timecode.

Name field Displays the current clip name. Click to enter another name or comment to be burned-in. The Name field is active when Comment is enabled.

Background button Enable if you want a colour box behind the text. To change the colour of the background, use the Background Colour pot.

Background Colour pot Click to display the colour palette and select a background colour.

Font box Click to select a font from the browser.

Vertical Position box Select a vertical position.

Select:	To position:
Vertical Center	The burned-in text in the vertical centre.
Top	The burned-in text to the top of the frame.
Bottom	The burned-in text to the bottom of the frame.

Size field Drag left or right, or click to enter the font size of the burned-in clip information.

Vertical Position field Drag left or right, or click to enter a vertical position value that offsets the selected option in the Offset box.

Keycode button Enable to burn-in the keycode.

- Frame Number button** Enable to burn-in the current frame number.
- Record Timecode button** Enable to burn-in the record timecode.
- Total Frames button** Enable to burn-in the total frame number.
- Source TC field** Click to enter a new source timecode value.
- Record TC field** Click to enter a new record timecode value.
- Keycode field** Click to enter a new keycode value.
- Source TC Frame Mode box** Select a frame code mode for the source clip.
- Record TC Frame Mode box** Select a frame code mode for the record clip.
- Total Frames field** Click to enter a value for the total number of frames.

Burning-in Clip Information

Use the Burn In tools to burn-in clip information such as timecode, keycode, and frame numbers. The information appears as text on your clip for your reference.

If you are mixing clips that originate from formats that use different timecode, you may want to burn-in information on a clip to keep a timecode reference clip.

NOTE Burn In settings are saved from session to session. You can reset them to the factory defaults by clicking Reset.

Burn-in the clip's keycode data with the Burn In tool. This ensures that keycode data is not lost as frames progress through the work pipeline of your Autodesk Visual Effects and Finishing application, and possibly through other applications. See [Ways that Timecode and Keycode is Preserved or Destroyed](#) on page 404.

You can also use the Burn-In Timecode node in Batch to burn-in keycode. Either enter a keycode value using the keycode calculator or use the keycode data contained in the clip.

To burn-in clip information from the Burn In menu:

- 1 In the Main menu, click Format.
- 2 In the Format menu, click Burn In.

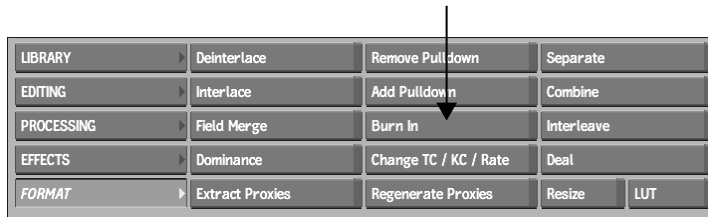

- 3 Enable the buttons for the clip information that you want to burn into the clip, such as Comments, Source Timecode, Keycode, and Date/Time. The selected information on the clip is shown in the sample frame. See [About the Burn In Menu](#) on page 425.

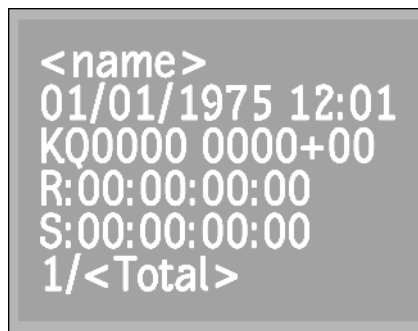

- 4 Click to edit any of the timecode or keycode fields.
- 5 Click Burn In.
- 6 Select the clip into which you want to burn in the clip information.
- 7 Select the destination for the result clip.
The result clip appears in the selected destination.

To burn-in clip information from the Burn-In Timecode node in Batch:

- 1 Add a Burn-In Timecode node to the schematic.

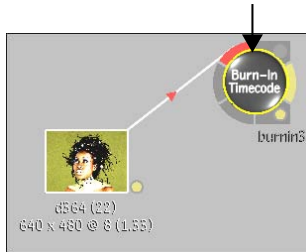

Image courtesy of The House

- 2 Select the Burn-In Timecode node to display its menu.

Text Colour	<input type="text" value=""/>	As Front	Safe Title	Comments	Frame Number	Total	100
Shadow	<input type="text" value=""/>	Horizontal Centre	Y 0	Date/Time	Keycode	No KC	
Background	<input type="text" value=""/>	Bottom	X 0	Source Timecode	00:00:00:00	29.97 fps NDF	
Font	Discreet		Size 50	Record Timecode	00:00:00:00	29.97 fps NDF	
<input type="text" value="<name>"/>							

- 3 Enable the buttons for the clip information that you want to burn into the clip, such as Comments, Source Timecode, Keycode, and Date/Time.
- 4 Click to edit any of the timecode or keycode fields.
- 5 To use the keycode data embedded in the clip, with the Burn-In node selected in the schematic, hold **T** while clicking the clip whose keycode you want to burn-in.

The keycode from the clip appears in the Keycode field of the Burn In menu.

NOTE Although you can burn-in the keycode onto the image, clips processed from Batch do not contain embedded keycode.

- 6 Continue working on your clip in Batch.

Importing Final Cut Pro XML

19

Topics in this chapter:

- [About Importing XML from Final Cut Pro](#) on page 431
- [Workflow](#) on page 432
- [Logging and Capturing from Tape in Final Cut Pro](#) on page 433
- [Exporting Sequences from Final Cut Pro](#) on page 433
- [Importing Final Cut Pro XML](#) on page 436
- [Relinking to File-based Media](#) on page 439
- [Recapturing Media From Tape](#) on page 440
- [Optimizing the Recapture of Footage Referenced in XML Files](#) on page 442
- [Supported and Unsupported Effects](#) on page 443

About Importing XML from Final Cut Pro

Flame allows you to import multi-track compositions from Apple® Final Cut Pro® (FCP) running on both PowerPC™ and X86 (Intel®) platforms. Flame reads XML exported from FCP (version 4.1 and up, exported as XML version 2.0) and assembles a timeline accordingly. Media used during the offline edit in FCP (such as QuickTime files, VTR captures, or image sequences) needs to be recaptured from the source tapes or relinked from files in Flame. XML exported

from FCP supports multiple tracks of video and audio effects and transitions in a single XML file. As well, more effects and transitions can be transferred between FCP and Flame. Only select effects are supported when transferring sequences between FCP and Flame.

When transferring projects between FCP and Flame, you are only transferring the metadata between the applications, as contained in the XML, and not the media itself. You need to import or soft-import the media in a separate procedure.

It is possible for FCP to export XML containing multiple timelines. However, Flame only supports XML containing a single timeline and cannot read XML files with multiple timelines. Ensure that the FCP editor exports only one timeline per XML file.

You can also load FCP XML linked to media shot on a Varicam.

Workflow

To provide a smooth transition when importing FCP XML files into Flame, follow these steps.

- 1 Prepare the sequences in FCP that will be exported as XML. Do one of the following:
 - If you are editing from tape, perform logging and capture from a VTR in FCP. See [Logging and Capturing from Tape in Final Cut Pro](#) on page 433.
 - If you are editing from files, verify that the supported media specifications and network configuration links are still valid for accessing the file-based media.
- 2 Edit and add effects and transitions in FCP. See [Supported and Unsupported Effects](#) on page 443.
- 3 Export XML sequences from FCP. See [Exporting Sequences from Final Cut Pro](#) on page 433.
- 4 Import the FCP XML, and then recapture or relink the media. See [Importing Final Cut Pro XML](#) on page 436.
- 5 Work on the recaptured project and finish it for final output.

Logging and Capturing from Tape in Final Cut Pro

If you are working from tapes, log and capture to FCP in a manner that allows the online editor to easily recapture media in Flame. You can also edit in FCP using file-based media. You can use both tape-based and file-based media in the same FCP project, and the media can be recaptured and relinked later in Flame.

You load XML files and either capture the source material from tape or relink the media to files.

When capturing clips for offline edit sessions in FCP, you enter the tape name in the Reel field of the Log and Capture dialog box. After importing the FCP XML in Flame, you recapture all the media from tape. It is this tape name, as entered in the Reel field in FCP, that indicates which tapes to use.

NOTE Other logging data entered for clips in the FCP Log and Capture dialog box can be imported into Flame. See [FCP to Flame: Data](#) on page 443.

The following resolution/framerates are supported for footage destined for Flame:

- NTSC@29.97
- PAL@25
- 720p24@23.976
- 720p30@29.97
- 720p60@59.94
- 1080i50@25
- 1080i60@29.97

The NTSC@24 (Advanced pulldown) framerate is not supported for footage destined for Flame.

Exporting Sequences from Final Cut Pro

When you are ready to export projects from FCP, you must export each sequence separately as an XML file, since Flame does not support Bins or Batch lists.

You can, however, export sequences which contain nested sequences and the nested sequences will be translated into containers in Flame.

Use the Final Cut Pro File menu to export FCP XML interchange format documents.

If you are exporting file-based XML, as opposed to tape, then you need to ensure that the following guidelines are met:

- Audio bit depth should be set to 16 bits.
- Capture audio by linking two channels to a single audio track.
- Use FCP's Media Manager to copy and recompress the files.

To move and recompress media using FCP Media Manager:

- 1 Select a sequence in the Browser window that you want to move and recompress, in preparation for export to Flame.

NOTE If nothing is selected, the entire contents of the Browser are exported. However, Flame only supports XML files with a single sequence of edited clips.

- 2 Choose File | Media Manager.

The Media Manager appears.

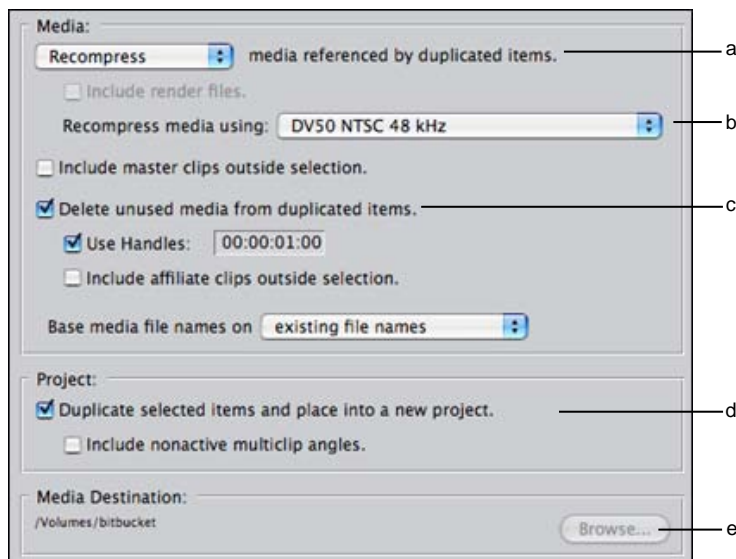

- (a) Media referenced by duplicated items box (b) Recompress media using box (c) Delete unused media from duplicated items checkbox (d) Duplicate selected items and place into a new project checkbox (e) Browse button

- 3 In the Media group, from the Media referenced by duplicated items box, select Recompress.
- 4 From the Recompress media using box, select a codec that is supported by Flame.
- 5 Ensure that the Delete unused media from duplicated items checkbox is set.
This option consolidates the media and ensures that Flame does not capture unnecessary footage.
- 6 In the Projects group, enable the Duplicate selected items and place into a new project checkbox.
This ensures that all media is placed in the same folder.
- 7 In the Media Destination group, click Browse to select a location for the media and project that is accessible by Flame.
- 8 Click OK.

To export XML from FCP:

- 1 Select a sequence in the Browser window that you want to export in an interchange format document.

NOTE If nothing is selected, the entire contents of the Browser are exported. However, Flame only supports XML files with a single sequence of edited clips.

- 2 Choose File | Export | XML.
- 3 In the Export XML dialog box, do the following:

- From the XML Format box, select Apple XML Interchange Format, version 2.

NOTE If you are exporting XML from an FCP version prior to 5, only version 1 of the XML Interchange Format version is available. In general, there is parity between both XML Interchange Format versions concerning supported effects in Flame. Features specific to FCP 5 will only appear in version 2 of FCP's XML Interchange Format.

- Ensure that the Include master clips outside selection checkbox is not enabled.

- 4 Click OK.
- 5 In the Save dialog box that appears, save the XML file to an accessible location.

Importing Final Cut Pro XML

Each XML file corresponds to an FCP sequence, including video, audio, and select transitions and effects, that can be opened in the timeline. Some unsupported effects are marked with comments indicating what you have to rebuild in Flame based on the original offline edit.

FCP XML can support 720/24p, 720/30p, and 720/60p output from Varicam to create XML files. The timecode of the source is always 59.94, but the timelines can be 24p, 30p, or 60p.

Flame has the ability to conform XML (23.976/29.97/59.94) from Varicam material (23.976/29.97/30/59.94/60). Flame can also remove non-active frames when capturing Varicam media. The source material must be at the same framerate as the sequence (for example 23.97 in a 23.97 sequence).

Before importing XML that contains any MXF P2 content, ensure that the P2 recording devices that are used are set to record clip metadata in Type 2. This allows important metadata, such as the User Clip Name, to be assigned properly in the XML file.

When importing FCP XML files that were created in SD resolution and that need to be conformed in HD, you will need to reformat the clips. See [Reformatting Clips](#) on page 273.

After importing an XML file, you recapture the footage from the original tapes using the Recapture tool. You can also reload file-based media. Once all the media is captured, imported, or soft-imported, you can relink it to the sequence.

To import or soft-import an FCP XML file:

- 1 In the clip library, from the Interchange Format box, select XML.

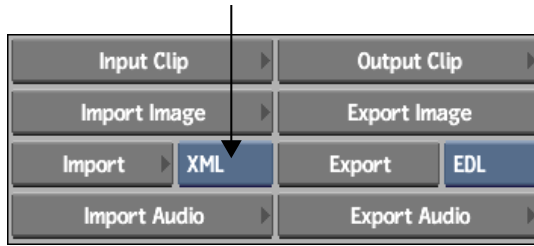

- 2 Click Import.
- 3 In the file browser, navigate to an XML file exported from FCP.
- 4 If you are importing FCP XML that contains media files, and your files are stored on other computers, you can use Wiretap to access them. Enter the host or group name, as configured in the *sw_wiretap_path_translation_db.xml* file.

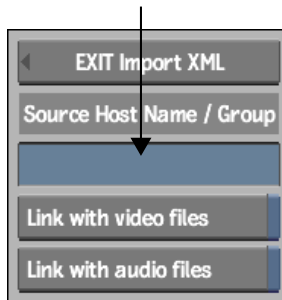

The Wiretap Server must be configured properly to recognize the different hosts that you want to retrieve media from. See the *Autodesk Stone and Wire Filesystem and Networking Guide* or contact your system administrator.

If you do not enter a value in the Source Host Name / Group field, any paths contained in the FCP XML file will be interpreted as pointing to your Flame workstation. You can change the path in the Recapture dialog when relinking.

- 5 If you are importing FCP XML that contains media files, you must enable Link with video files and/or Link with audio files.

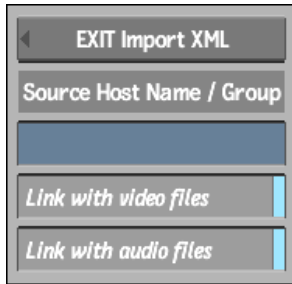

- Click Load.
The Recapture menu appears.

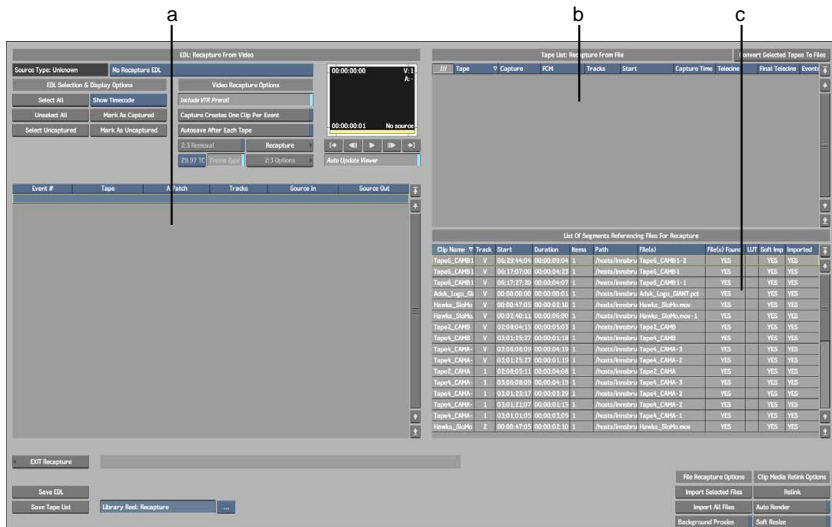

(a) Clip List: List of Clips on Tape (b) Tape List: Recapture From File (c) List of Segments Referencing Files For Recapture

- If you are importing FCP XML that references media clips from tapes, a list of clips appears in the Clip List. A list of source tapes also appears in the Tape List. This is the same tape list as logged in FCP. See [Recapturing Media From Tape](#) on page 440.
- If you are importing FCP XML that contains media files, a list of files appears in the List of Segments. This is the list that you need to relink. See [Relinking to File-based Media](#) on page 439.

Relinking to File-based Media

If, in Final Cut Pro, you edited sequences using file-based media, such as QuickTime movies, you can then relink the exported XML to these files in Flame.

Verify that the files you are relinking to are supported in Flame. See [Supported File Formats](#) on page 194.

You can relink imported FCP XML files to file-based video or audio media.

If you are importing FCP XML with Varicam support, it will be identified as such in the Source Type box.

To relink FCP XML to file-based media:

- 1 Ensure that the path to your media files is correct. To change the path, drag to select the media segments in the list, and then click in the Path field.

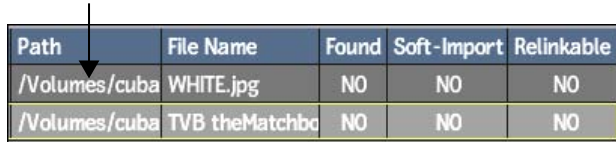

Path	File Name	Found	Soft-Import	Relinkable
/Volumes/cuba	WHITE.jpg	NO	NO	NO
/Volumes/cuba	TVB theMatchbc	NO	NO	NO

Once the path is correct, the Found field will display YES for each segment found.

- 2 If you want to soft-import the media files, drag to select the segments in the list and then, in the Soft-Import column, drag left or right to toggle between NO and YES.

Note that not all files can be soft-imported (for example, audio files at 44.1 kHz).

- 3 Click Import All Files.

All the files are now imported or soft-imported but not yet relinked. The Relinkable column displays whether the file is relinkable.

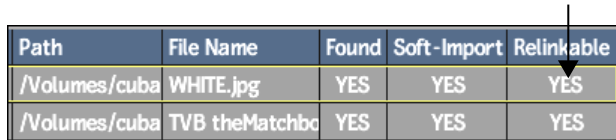

Path	File Name	Found	Soft-Import	Relinkable
/Volumes/cuba	WHITE.jpg	YES	YES	YES
/Volumes/cuba	TVB theMatchbc	YES	YES	YES

- 4 Ensure that all media files are relinkable. Click the Relinkable header to sort the list and group any NOs at the top.

Some files that are not relinkable may only need to be resized so as to be compatible. For example, the Soft Resize feature allows you to import Quicktime files, included with the FCP XML, at 720x480 instead of the usual NTSC 720x486.

- 5 Select the files that are not relinkable, enable Soft Resize, and then click Import Selected Files.

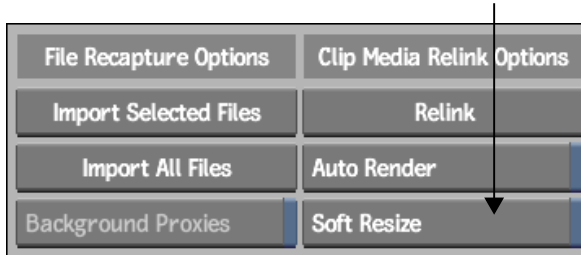

If the files are still not relinkable then they cannot be soft-imported. Try to import the files normally, or check with your system administrator.

- 6 Click Relink.
A new reel with the XML filename is created in the clip library for each imported XML file. The assembled clip in the new reel has the same name as the original FCP sequence.

Recapturing Media From Tape

After importing an XML file, you recapture the source material from the original tapes using the Recapture tool.

To recapture media from tape:

- 1 Recapture all the source material from the original sources as indicated in the tape list. See [Recapturing Media](#) on page 280.

NOTE If your assembled clip references media that has already been recaptured, the material does not have to be recaptured again. As well, it is recommended that you consolidate clips before recapturing. See [Optimizing the Recapture of Footage Referenced in XML Files](#) on page 442.

If you are using NTSC or PAL DV footage in FCP, the clips will be recaptured at a different resolution in Flame.

FCP Resolution	Recaptured Resolution in Flame
NTSC DV = 720 x 480	NTSC = 720 x 486
PAL DV = 720 x 576	PAL = 720 x 576
DVCPRO HD - 1080i50 = 1440 x 1080	HD 1080 = 1920x1080
DVCPRO HD - 1080i60 = 1280 x 1080	HD 1080 = 1920x1080
DVCPRO HD 720p24 = 960 x 720	HD 720 = 1280 x 720
DVCPRO HD 720p30 = 960 x 720	HD 720 = 1280 x 720
DVCPRO HD 720p60 = 960 x 720	HD 720 = 1280 x 720
HDV 1080i50 = 1440 x 1080	HD 1080 = 1920x1080
HDV 1080i60 = 1440 x 1080	HD 1080 = 1920x1080
HDV 720p30 = 1280 x 720	HD 720 = 1280 x 720
OfflineRT NTSC = 320 x 240	NTSC = 720 x 486
OfflineRT PAL = 320 x 240	PAL = 720 x 576

After recapturing and relinking the sequence, exit the Recapture menu to see the clip in the current clip library. A new reel appears in the library. This reel is named the same as the XML file with the added suffix *XML Import*. Within the reel, the clip assembled from the FCP XML is named the same as the sequence in FCP.

NOTE If you load XML files with the same name, the clips that are created from them are added to the same reel.

You can load the reassembled clip into the timeline and proceed to tweak the effects added in FCP.

Optimizing the Recapture of Footage Referenced in XML Files

There are two methods that can help you achieve a more efficient workflow as you import projects from FCP via XML. You can consolidate clips before recapturing to reduce the amount of extra footage, or you can relink clips to already captured media if multiple XML files use the same footage.

Consolidating Clips

After importing an XML file and prior to recapturing it, it is strongly recommended that you consolidate your clip in Flame. This ensures that you do not capture all the extra media that was likely captured during the offline edit. This step should be performed even if a similar process was performed in FCP.

You can consolidate clips in the clip library. See [Consolidating Clips](#) on page 311.

In general, it is recommended that you use the All Tracks option, available from the Consolidate option box, to consolidate all segments of an unlinked clip. See [About Managing Media on the Timeline](#) on page 1179.

Relinking to Already Captured Material

If you import multiple XML files that reference the same footage, you do not have to recapture the footage each time. Instead, you can relink the clip to media on the same reel.

To relink an imported FCP XML file to already recaptured clips:

- 1 After importing an FCP XML file, change the Library Reel to the reel where the media is located.



- 2 Click Relink.

The clip is linked to media on the reel that is referenced in the XML file.

- 3 If necessary, recapture any missing media. See [Recapturing Media](#) on page 280.

Supported and Unsupported Effects

The information in this section indicates how FCP data and effects map to Flame data, transitions, and Batch FX. Unsupported transitions and effects are indicated as not supported.

In some cases, a comment indicates how an unsupported effect is translated in Flame. For example, the FCP colour Tint Video Filter (QuickTime) is not supported in Flame. It is replaced by a Colour Correction soft effect, from which the colour tint effect can be rebuilt. A comment is added to indicate the name of the original FCP effect.

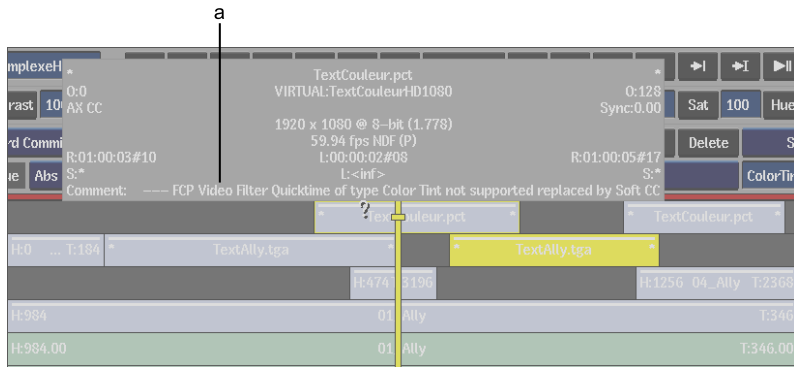

(a) comment

Keyframe animation applied to effect parameters from FCP is mapped to Flame.

FCP to Flame: Data

The following tables describe the data that is output from FCP and input into Flame.

General Data

FCP composition(s) data maps to Flame timeline data.

Final Cut Pro	Flame
Name	Name
Framerate	Framerate
Duration	Duration

Editorial Data

FCP Source media data and Record side data maps to Autodesk source clip and record clip data.

Final Cut Pro	Flame
Source media data: <ul style="list-style-type: none">■ Tape name■ Source TC in/out■ Edge code■ Log notes■ Aspect ratio■ Comments	Source clips: <ul style="list-style-type: none">■ Tape name■ Source TC in/out■ Keycode■ Elements comments■ Aspect ratio■ Elements Comments
Record side data: <ul style="list-style-type: none">■ In/Out■ Transition type■ Number of video tracks■ Number of audio tracks■ Marker■ In/Out marker	Record clip: <ul style="list-style-type: none">■ Segment■ Cut/Dissolve/Wipe/Axis■ Video layers■ Audio tracks■ Track marks■ In/Out marks

Effect Data

FCP transitions map to Flame transitions, while FCP Filter effects and FX Script data map to Flame soft effects.

Final Cut Pro	Flame
Filter effects	Soft effects
Transitions	Transitions

FCP to Flame: Animation

The following table describes how animation from FCP is mapped to Flame animation.

Animation Interpolation Types

FCP animation interpolation maps to Autodesk interpolation.

Final Cut Pro	Flame
Corner	Linear
Smooth	Hermite

FCP to Flame: Motion

The following table describes how motion from FCP is mapped to Flame Axis soft effect parameters.

Motion

FCP motion maps to Autodesk Axis soft effect parameters.

Final Cut Pro	Flame
Basic Motion	Axis Axis
Crop	Axis Edges
Distort	Axis Surface
Opacity	Axis Transparency (partially supported)

Final Cut Pro	Flame
Drop Shadow	Axis Shadow
Motion Blur	Not supported
Time Remap	Timewarp (see below)

About Time Remap to Timewarp

FCP Time Remap, both constant and variable, is translated into constant and variable timewarps with keyframes in Flame, except for the following:

- Frame blending used with this effect is not translated.
- Negative constant timewarp speeds are not applied to the audio tracks of the segment being timewarped.
- Variable timewarps are not applied to the audio tracks of the segment being timewarped.

FCP to Flame: Video Transitions

The names of FCP transitions are preserved in Flame and are visible in the timeline.

3D Simulation

Final Cut Pro	Flame
Cross Zoom	Dissolve (partially supported)
Cube Spin	Dissolve (partially supported)
Spin 3D	Axis transition (partially supported)
Spinback 3D	Not supported; replaced by Dissolve
Swing	Axis transition (partially supported)
Zoom	Axis transition (partially supported)

Dissolve

Final Cut Pro	Flame
Additive Dissolve	Not supported; replaced by Dissolve
Cross Dissolve	Dissolve Additive
Dip to colour Dissolve	Dissolve To/From colour (partially supported)
Dither Dissolve	Not supported; replaced by Dissolve
Fade in/fade out Dissolve	Dissolve To/From Black (partially supported)
Non-Additive Dissolve	Dissolve Non-Additive
Ripple Dissolve	Not supported; replaced by Dissolve

Iris

Final Cut Pro	Flame
Cross Iris	SMPTE 007 (partially supported)
Diamond Iris	SMPTE 102 (partially supported)
Oval Iris	SMPTE 119, 120, or 121 (partially supported)
Point Iris	SMPTE 047 (partially supported)
Rectangle Iris	SMPTE 101 (partially supported)
Star Iris	SMPTE 127, 128, or 129 (partially supported)

Map

Final Cut Pro	Flame
Channel Map	Not supported; replaced by Dissolve
Luminance Map	Not supported; replaced by Dissolve

Page Peel

Final Cut Pro	Flame
Page Peel	Not supported; replaced by Dissolve

QuickTime

Final Cut Pro	Flame
Channel Compositor	Not supported; replaced by Dissolve
Chroma Key	Not supported; replaced by Dissolve
Explode	Not supported; replaced by Dissolve
Gradient Wipe	Not supported; replaced by SMPTE 002 without Softness
Implode	Not supported; replaced by Axis transition
Iris	<p>SMPTE Wipes (partially supported):</p> <ul style="list-style-type: none">■ Rectangle = SMPTE 101■ Diamond = SMPTE 102■ Triangle = SMPTE 103■ Triangle Right = SMPTE 104■ Triangle Upside Down = SMPTE 105■ Triangle Left = SMPTE 106■ Arrowhead = SMPTE 107■ Arrowhead Right = SMPTE 108■ Arrowhead Upside Down = SMPTE 109■ Arrowhead Left = SMPTE 110■ Pentagon = SMPTE 111■ Pentagon Upside Down = SMPTE 112■ Hexagon = SMPTE 113■ Hexagon Side= SMPTE 114■ Circle = SMPTE 119■ Oval = SMPTE 120■ Oval Side = SMPTE 121■ Cat Eye = SMPTE 122■ Cat Eye Side = SMPTE 123■ Round Rect = SMPTE 124■ Round Rect Side = SMPTE 125■ 4 Point Star = SMPTE 127■ 5 Point Star = SMPTE 128

Final Cut Pro	Flame
	<ul style="list-style-type: none"> ■ 6 Point Star = SMPTE 129 ■ Heart = SMPTE 130 ■ Keyhole = SMPTE 131
Matrix Wipe	Not supported; replaced by SPMTE 001 with a comment indicating the type of FCP Matrix Wipe that had been at this mark
Push	Not supported; replaced by Dissolve
Radial	<p>SMPTE Wipes (partially supported):</p> <ul style="list-style-type: none"> ■ Rotating Top = SMPTE 201 ■ Rotating Right = SMPTE 202 ■ Rotating Bottom = SMPTE 203 ■ Rotating Left = SMPTE 204 ■ Rotating Left Bottom = SMPTE 205 ■ Rotating Left Right = SMPTE 206 ■ Rotating Quadrant = SMPTE 207 ■ Top to Bottom 180 degree = SMPTE 211 ■ Right to Left 180 degree = SMPTE 212 ■ Top to Bottom 90 degree = SMPTE 213 ■ Right to Left 90 degree = SMPTE 214 ■ Top 180 Degree = SMPTE 221 ■ Right 180 Degree = SMPTE 222 ■ Bottom 180 Degree = SMPTE 223 ■ Left 180 Degree = SMPTE 224 ■ Counter Rotating Top Bottom = SMPTE 225 ■ Counter Rotating Left Right = SMPTE 226 ■ Double Rotating Top Bottom = SMPTE 227 ■ Double Rotating Left Right = SMPTE 228 ■ V Open Top = SMPTE 231 ■ V Open Right = SMPTE 232 ■ V Open Bottom = SMPTE 233 ■ V Open Left = SMPTE 234

Final Cut Pro	Flame
	<ul style="list-style-type: none"> ■ V Open Top Bottom = not supported; replaced by SMPTE 001 ■ V Open Left Right = not supported; replaced by SMPTE 001 ■ Rotating Top Left = SMPTE 241 ■ Rotating Bottom Left = SMPTE 242 ■ Rotating Bottom Right = SMPTE 243 ■ Rotating Top Right = SMPTE 244 ■ Rotating Top Left Bottom Right = SMPTE 245 ■ Rotating Bottom Left to Top Right = SMPTE 246 ■ Rotating Top Left Right = SMPTE 251 ■ Rotating Left Top Bottom = SMPTE 252 ■ Rotating Bottom Left Right = SMPTE 253 ■ Rotating Right Top Bottom = SMPTE 254 ■ Rotating Double Center Right = not supported; replaced by SMPTE 001 ■ Rotating Double Center Top = not supported; replaced by SMPTE 001 ■ Rotating Double Center Top Bottom = not supported; replaced by SMPTE 001) ■ Rotating Double Center Left Right = not supported; replaced by SMPTE 001
Slide	Axis transition
Wipe	SMPTE Wipes (various partially supported): <ul style="list-style-type: none"> ■ Slide Horizontal = SMPTE 001 ■ Slide Vertical = SMPTE 002 ■ Top Left = SMPTE 003 ■ Top Right = SMPTE 004 ■ Bottom Right = SMPTE 005 ■ Bottom Left = SMPTE 006 ■ Four Corner = SMPTE 007 ■ Four Box = SMPTE 008

Final Cut Pro	Flame
	<ul style="list-style-type: none"> ■ Barn Vertical = SMPTE 021 ■ Barn Horizontal = SMPTE 022 ■ Top Center = SMPTE 023 ■ Right Center = SMPTE 024 ■ Bottom Center = SMPTE 025 ■ Left Center = SMPTE 026 ■ Diagonal Left Down = SMPTE 041 ■ Diagonal Right Down = SMPTE 042 ■ Vertical Bow Tie = SMPTE 043 ■ Horizontal Bow Tie = SMPTE 044 ■ Diagonal Left Out = SMPTE 045 ■ Diagonal Right Out = SMPTE 046 ■ Diagonal Cross = SMPTE 047 ■ Diagonal Box = SMPTE 048 ■ Filled V = SMPTE 061 ■ Filled V Right = SMPTE 062 ■ Filled V Bottom = SMPTE 063 ■ Filled V Left = SMPTE =064 ■ Hollow V = SMPTE 065 ■ Hollow V Right = SMPTE 066 ■ Hollow V Bottom = SMPTE 067 ■ Hollow V Left = SMPTE 068 ■ Vertical Zig Zag = SMPTE 071 ■ Horizontal Zig Zag = SMPTE 072 ■ Vertical Barn Zig Zag = SMPTE 073 ■ Horizontal Barn Zig Zag = SMPTE 074
Zoom	Axis transition (partially supported)

Slide

Final Cut Pro	Flame
Band Slide	Not supported; replaced by Dissolve
Box Slide	Not supported; replaced by Dissolve
Center Split Slide	Not supported; replaced by Dissolve
Multi Spin Slide	Not supported; replaced by Dissolve
Push Slide	Not supported; replaced by Dissolve
Spin Slide	Not supported; replaced by Dissolve
Split Slide	Not supported; replaced by Dissolve
Swap Slide	Not supported; replaced by Dissolve

Stretch

Final Cut Pro	Flame
Cross Stretch	Not supported; replaced by Dissolve
Squeeze	Axis transition (partially supported)
Squeeze and Stretch	Not supported; replaced by Axis Transition
Stretch	Axis transition (partially supported)

Wipe

Final Cut Pro	Flame
Band	Not supported
Center Wipe	SMPTE 021 (partially supported)
Checker Wipe	Not supported
Checkerboard Wipe	Not supported
Clock Wipe	SMPTE 201 (partially supported)
Edge Wipe	SMPTE 001 (partially supported)

Final Cut Pro	Flame
Gradient Wipe	Not supported
Inset Wipe	<ul style="list-style-type: none"> ■ Upper Left = SMPTE 003 (partially supported) ■ Top = SMPTE 023 ■ Upper Right = SMPTE 004 ■ Right = SMPTE 024 ■ Lower Right = SMPTE 005 (reverse) ■ Bottom = SMPTE 025 ■ Lower Left = SMPTE 006 (reverse) ■ Left = SMPTE 026
Jaws Wipe	SMPTE 073 (partially supported, FCP's is smaller than Flame's)
Random Edge Wipe	Not supported; replaced by Wipe 001 transition
V Wipe	<ul style="list-style-type: none"> ■ Right = SMPTE 064 (partially supported) ■ Down = SMPTE 61 ■ Left = SMPTE 62 ■ Up = SMPTE 63
Venetian Blind Wipe	Not supported; replaced by SMPTE 001
Wrap Wipe	Not supported; replaced by SMPTE 001
Zig-Zag Wipe	Not supported; replaced by SMPTE 001

FCP to Flame:Video Filters

Blur

The following tables describe how video filter effects from FCP are mapped to Flame.

Final Cut Pro	Flame
Gaussian Blur	Axis Surface + Axis (partially supported)

Final Cut Pro	Flame
Radial Blur	Not supported
Wind Blur	Not supported
Zoom Blur	Not supported
Border	
Final Cut Pro	Flame
Basic Border	Soft Resize
Bevel	Not supported
Channel	
Final Cut Pro	Flame
Arithmetic	Not supported
Channel Blur	Not supported
Channel Offset	Not supported
Colour Offset	Soft CC (partially supported)
Compound Arithmetic	Not supported
Invert	Soft CC Basics (partially supported)
Colour Correction	
Final Cut Pro	Flame
Broadcast Safe	Not supported
Colour Correction	Not supported; replaced by Soft CC
Colour Correction 3-way	Not supported; replaced by Soft CC
Desaturate Highlights	Not supported
Desaturate Lows	Not supported
RGB Balance	Not supported; replaced by Soft CC

Distort

Final Cut Pro	Flame
Bumpmap	Not supported
Cylinder	Not supported
Displace	Not supported
Fisheye	Not supported
Pond Ripple	Not supported
Ripple	Not supported
Wave	Not supported
Whirlpool	Not supported

Image Control

Final Cut Pro	Flame
Brightness & Contrast (Bezier)	Not supported; replaced by Soft CW
Colour Balance	Not supported; replaced by Soft CC
Desaturate	Soft CC
Gamma Correction	Not supported; replaced by Soft CW
Levels	Not supported
Proc Amp	Not supported; replaced by Soft CC
Sepia	Not supported; replaced by Soft CC
Tint	Not supported

Key

Final Cut Pro	Flame
Blue and Green screen	Not supported

Final Cut Pro	Flame
Chroma Keyer	Not supported; replaced by Soft Axis
Colour Smoothing 4:1:1	Not supported
Colour Smoothing 4:2:2	Not supported
Colour Key	Not supported; replaced by Soft Axis
Difference Matte	Not supported
Luma Key	Not supported
Spill Suppressor - Blue	Not supported; replaced by Soft Axis
Spill Suppressor - Green	Not supported; replaced by Soft Axis

Matte

Final Cut Pro	Flame
8-Point Garbage Mask	Not supported; replaced by Soft Axis
Extract	Not supported
4-Point Garbage Mask	Not supported; replaced by Soft Axis
Image Mask	Not supported; replaced by Soft Axis
Mask Feather	Not supported
Mask Shape	Soft Axis (partially supported)
Matte Choker	Not supported; replaced by Soft Axis
Soft Edges	Not supported; replaced by Soft Axis
Widescreen	Soft Resize (partially supported)

Perspective

Final Cut Pro	Flame
Basic 3D	Soft Axis Axis (partially supported)
Curl	Not supported

Final Cut Pro	Flame
Flop	Soft Axis Axis
Mirror	Not supported
Rotate	Soft Axis Axis

QuickTime

Final Cut Pro	Flame
Gaussian Blur	Soft Axis Axis
Brightness/Contrast	Not supported; replaced by Soft CC
Colour Style	Not supported
Colour Tint	Soft CC (partially supported)
Colour Sync	Not supported
Edge Detection	Not supported
Emboss	Not supported
General Convolution	Not supported
HSL Balance	Not supported; replaced by Soft CC
Lens Flare	Not supported
RGB Balance	Not supported; replaced by Soft CC
Sharpen	Not supported

Sharpen

Final Cut Pro	Flame
Sharpen	Not supported
Unsharp Mask	Not supported

Stylize

Final Cut Pro	Flame
Anti-Alias	Not supported
Diffuse	Not supported
Emboss	Not supported
Find Edges	Not supported
Posterize	Not supported
Replicate	Not supported
Solarize	Not supported

Video

Final Cut Pro	Flame
Blink	Soft Axis
De-Interlace	Soft Resize (partially supported)
Flicker Filter	Not supported
Image Stabilizer	Not supported; replaced by Axis Stabilizer
Stop Motion Blur	Not supported
Strobe	Timewarp Strobe
Timecode Generator	Not supported
Timecode Reader	Not supported
Viewfinder	Not supported

FCP to Flame: Video Generator

The following tables describe generated effects that are translated into equivalent effects in Flame.

Once imported into Flame, effects created with the FCP video generator use the project's default resolution, regardless of their original resolution in FCP. This matches the behaviour of FCP: XML files with these effects that are reimported into FCP projects with different resolutions similarly inherit the project's resolution.

Video Generator

Final Cut Pro	Flame
Bars and Tone HD108060i	Colour Source SMPTE Bars (partially supported)
Bars and Tone HD720p60	Colour Source SMPTE Bars (partially supported)
Bars and Tone (NTSC)	Colour Source SMPTE Bars (partially supported)
Bars and Tone (PAL)	Colour Source SMPTE Bars (partially supported)
Slug	Black colour Source SMPTE Bars (partially supported)

Matte

Final Cut Pro	Flame
Colour	Colour Source (Fill Colour): <ul style="list-style-type: none"> ■ R = 0-255 ■ G = 0-255 ■ B = 0-255

Others

Final Cut Pro	Flame
More Bars and Signals	Not supported

Render

Final Cut Pro	Flame
Custom Gradient	Not supported
Gradient	Not supported
Highlight	Not supported

Final Cut Pro	Flame
Noise	Colour Source Noise
Particle Noise	Not supported

Shapes

Final Cut Pro	Flame
Circle	Not supported
Oval	Not supported
Rectangle	Not supported
Square	Not supported

Text

Final Cut Pro	Flame
Crawl	Soft Text (partially supported)
Lower 3rd	Soft Text (partially supported)
Outline Text	Soft Text (partially supported)
Scrolling Text	Soft Text (partially supported)
Text	Soft Text (partially supported)
Typewriter	Not supported; replaced by Colour Source

FCP to Flame:Audio

Some FCP audio elements are mapped to Flame equivalents.

Audio Transitions

Final Cut Pro	Flame
Cross Fade (0dB)	Audio fade (partially supported)
Cross Fade (+3dB)	Not supported; replaced by Audio Fade

Audio Controls

Final Cut Pro	Flame
Stereo	Audio Gain (partially supported)

Apple

Final Cut Pro	Flame
AuBandPass	Not supported
AuDelay	Not supported
AuDynamicProcessor	Not supported
AuGraphicsEQ	Not supported
AuHighShelfFilter	Not supported
AuHighPass	Not supported
AuLowPass	Not supported
AuLowShelfFilter	Not supported
AuMultibandCompress	Not supported
AuParametricEQ	Not supported
AuPeakLimiter	Not supported

Final Cut Pro HD

Final Cut Pro	Flame
3 Band Equalizer	Not supported
Band Pass Filter	Not supported
Compressor/Limiter	Not supported
DC Notch	Not supported
Echo	Not supported
Expander/Noise Gate	Not supported

Final Cut Pro	Flame
High Pass Filter	Not supported
High Shelf Filter	Not supported
Hum Remover	Not supported
Low Pass Filter	Not supported
Low Shelf Filter	Not supported
Notch Filter	Not supported
Parametric Equalizer	Not supported
Reverberation	Not supported
Vocal DeEsser	Not supported
Vocal DePopper	Not supported

FCP to Flame: Composite Mode

Some FCP composite modes are mapped to Flame Axis surface blend modes.

Composite Modes

Final Cut Pro	Flame
Modify	<ul style="list-style-type: none"> ■ Add = Add (partially supported) ■ Subtract = Subtract ■ Difference = Negate ■ Multiply = Multiply ■ Screen = Screen ■ Overlay = not supported ■ Hard Light = not supported ■ Soft Light = not supported ■ Darken = Min ■ Lighten = Max ■ Travel Matte - Alpha = not supported

Final Cut Pro**Flame**

- Travel Matte - Luma = not supported
 - Normal = not supported
-

Importing Subtitle XML

20

Topics in this chapter:

- [About Subtitle XML](#) on page 465
- [Workflow](#) on page 466
- [Importing Subtitle XML Files](#) on page 466
- [Adding Subtitle XML Files to the Timeline](#) on page 468
- [Editing Subtitle XML Files](#) on page 469
- [Subtitle XML Syntax](#) on page 470

About Subtitle XML

Subtitle XML allows you to easily add subtitles to a timeline. Subtitle XML can contain multiple versions of the text, for example, in different languages. Subtitle XML files are human-readable text files that can be edited in any text editor.

You can import a Subtitle XML file from the Interchange menu, similar to a Final Cut Pro XML file.

The Subtitle XML file is imported as a single-layer clip with Text Soft effects applied as Gap effects at each subtitle interval. You can then add the clip to an

existing timeline to apply the subtitles to it. Each of the Text Soft effects contained in the Subtitle XML clip are editable.

To learn more about:	See:
Soft Effects	Soft Effects on page 1111.
Gap Effects	Creating Gap Effects on page 1145.

Workflow

To use Subtitle XML, you need to import it and then add it to your timeline.

- 1 Import Subtitle XML from the Interchange menu. See [Importing Subtitle XML Files](#) on page 466.
- 2 Add the Subtitle XML clip to the timeline you are working on. See [Adding Subtitle XML Files to the Timeline](#) on page 468.
- 3 Other things you can do:
 - Create different versions of your clip for different audiences by working with multiple Subtitle XML layers. See [Working with Multiple Subtitle XML Files for Clip Versioning](#) on page 468.
 - Edit a Subtitle XML file in a text editor. See [Editing Subtitle XML Files](#) on page 469.

Importing Subtitle XML Files

You can import Subtitle XML files from the Interchange menu.

To import a Subtitle XML file:

- 1 In the clip library, from the Interchange Format box, select XML.

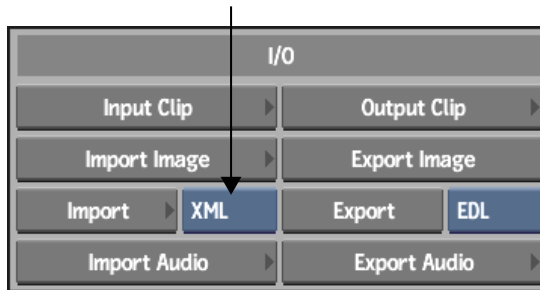

- 2 Click Import.
- 3 In the file browser, navigate to a Subtitle XML file, then select it.

TIP You can select multiple XML files to import.

- 4 Click Load.
The Recapture menu appears.

- 5 Click Exit Recapture.

A new reel appears with an unrendered clip containing the Subtitle XML file. The reel's name is the same as the Subtitle XML filename. The clip's name is retrieved from the name element in the XML code. See [Basic Elements](#) on page 471.

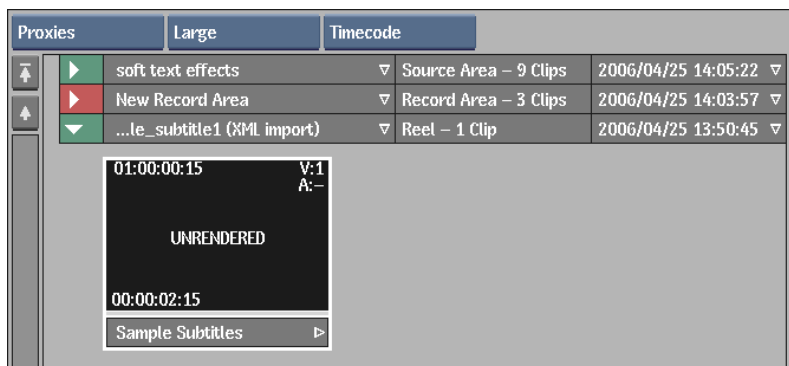

- 6 Do one of the following:
 - To see the Subtitles in the clip library, use the clip library tools to render the clip. See [Processing Clips and Proxies](#) on page 305.
 - To load the clip to the Desktop, select it, then click Load.

- Add the Subtitle XML file to the timeline. See [Adding Subtitle XML Files to the Timeline](#) on page 468.

Adding Subtitle XML Files to the Timeline

Add the Subtitle XML clip to a timeline. Soft Text effects appear (applied to gaps) on the layer at intervals as indicated in the Subtitle XML clip.

You can also correct timing discrepancies by moving the gap (which has the Soft Text effect applied) in the timeline.

To add a Subtitle XML layer to the timeline:

- 1 Add a layer to the timeline.
- 2 Move the positioner's focus point to the beginning of the new track where you want to add the Subtitle XML clip.
- 3 Select the Subtitle XML clip on the Desktop.
- 4 Press Insert (**G**) or Overwrite (**H**).

The Subtitle XML clip is added to the timeline. Soft Text effects appear on gaps at the intervals indicated in the Subtitle XML.

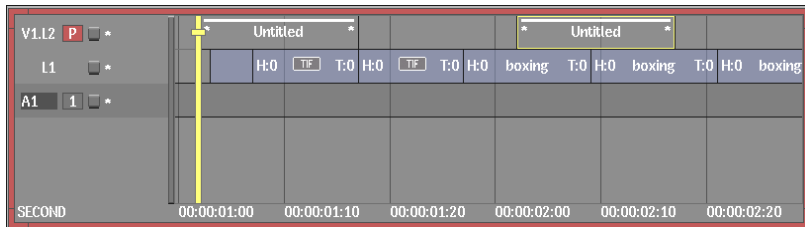

Working with Multiple Subtitle XML Files for Clip Versioning

You can add multiple Subtitle XML clips to a timeline, then mute all but the layer you want to process. With this method you can quickly version a clip.

To work with multiple Subtitle XML layers in the timeline:

- 1 Stack multiple Subtitle XML clips onto layers of a timeline.

- 2 Hold **Ctrl** and click the track identifier on all the layers you want to mute.

NOTE A muted layer has a yellow track indicator.

- 3 Drag the timeline onto the Clip Library box to save the clip. The clip is saved with only the selected subtitles appearing.
- 4 Repeat steps 2 and 3, alternating the subtitles that appear. To show a muted layer, hold **Ctrl** and click its track identifier again.

TIP The top layer cannot be muted.

Editing Subtitle XML Files

You can edit Subtitle XML files in any text editor. This is especially convenient for making multiple versions of the text, for example, in different languages, and not having to do so on the Flame workstation.

To edit a Subtitle XML file in a text editor:

- 1 Open a Subtitle XML file in a text editor such as kedit on Linux, Notepad on Windows, or TextEdit on Macintosh.

TIP Sample Subtitle XML files are available in */usr/discreet/xml/<version>/samples*.

- 2 Edit the file using the proper Subtitle XML syntax. See [Subtitle XML Syntax](#) on page 470.
- 3 Save the Subtitle XML file. Make sure the file maintains the *.xml* file extension to be read properly in Flame.
- 4 If necessary, check the validity of the Subtitle XML file. You can now import the Subtitle XML file from the Interchange menu. See [Importing Subtitle XML Files](#) on page 466.

To check if the Subtitle XML file is valid:

- 1 Open up the Subtitle XML file in an application that reads XML files, for example, Internet Explorer.

In Internet Explorer, you can collapse or expand each element, and easily see if there are mistakes in the structure of the XML, since it is colour coded.

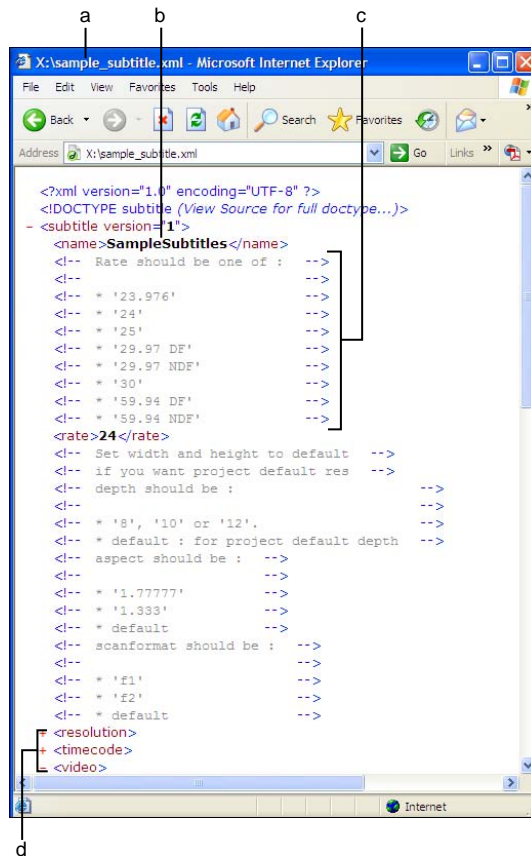

(a) Subtitle XML file in Internet Explorer (b) Name of Subtitle XML file in <name> element (c) Commented values for Rate element (d) Elements can be collapsed or expanded by clicking + or -

Subtitle XML Syntax

Subtitle XML files are human-readable, editable text files. Use the following syntax to work with Subtitle XML files external to the Flame workstation.

Basic Elements

The basic elements define the name, timecode, and body (as indicated by the <video> element) of the Subtitle XML file.

<name></name>

Description An element that defines the name of the Subtitle XML file. This name appears as the name of the clip which is created when importing a Subtitle XML file.

Attributes none

Sample <name>French version: Day at the Races</name>

<rate></rate>

Description A format element that describes the framerate of the Subtitle XML clip that appears in Flame after importing the Subtitle XML file.

Attributes none

Sample <rate>59.94 NDF</rate>

<resolution></resolution>

Description A format element that wraps around all of the attributes determining the format of the clip when importing a Subtitle XML file. This clip can then be resized within Flame like any other clip, if necessary.

Attributes <width></width>
The width of the imported Subtitle XML clip.
<height></height>
The height of the imported Subtitle XML clip.
<depth></depth>
The bit depth of the imported Subtitle XML clip.
<aspect></aspect>
The aspect ratio of the imported Subtitle XML clip.
<scanformat></scanformat>
The scanformat of the imported Subtitle XML clip.

Sample <resolution>
<width>1920</width>

```
<height>1080</height>
<depth>8</depth>
<aspect>1.778</aspect>
<scanformat>default</scanformat>
</resolution>
```

<timecode></timecode>

Description An element that defines the timecode in and out points during which the subtitles occur. All the titles in the Subtitle XML file will occur during the timecode indicated here, with each title also having its own start and end point indicated within the title elements. See [Title Elements](#) on page 473.

Attributes `<start></start>`
The start timecode of the subtitle sequence.
`<end></end>`
The end timecode of the subtitle sequence.

Sample `<timecode>`
`<start>01:00:00;00</start>`
`<end>01:00:08;00</end>`
`</timecode>`

<video></video>

Description The `<video>` element wraps around all of the `<title>` elements, which in turn contain the text and attributes of individual subtitles. See [Title Elements](#) on page 473.

Attributes `<title></title>`
The `<title>` element wraps around each subtitle, with its associated start and end time, text, and font style and position parameters. See [Title Elements](#) on page 473.

Sample `<video>`
`<title>`
`<start>01:00:01;00</start>`
`<end>01:00:02;00</end>`
`<text>This is a subtitle string</text>`
`Garamond`
`<size>20</size>`
`<fontcolor>`

```
<alpha>255</alpha>
<red>255</red>
<green>255</green>
<blue>255</blue>
</fontcolor>
<vertical>0</vertical>
<horizontal>0</horizontal>
<setup>/usr/discreet/pro-
ject/test/text/paz.ttg</setup>
</title>
<title>
</title>
</video>
```

Title Elements

Each `<title></title>` element defines a single subtitle which will appear as a Soft Text effect applied to a gap once imported into Flame, and added to a timeline.

The font style, colour, size, and position parameters are overridden if a valid text setup file is referenced within the `<title>` element.

`<start></start>`

Description The start timecode of the current subtitle

Attributes none

Sample `<start>01:00:01;00</start>`

`<end></end>`

Description The end timecode of the current subtitle

Attributes none

Sample `<end>01:00:02;00</end>`

`<text></text>`

Description The text of the current subtitle

Attributes none

Sample `<text>This is a subtitle string</text>`

``

Description The font of the current subtitle. This value is overridden if a valid text setup file is referenced in the `<setup>` element.

Attributes none

Sample `Garamond`

`<size></size>`

Description The font size of the current subtitle. This value is overridden if a valid text setup file is referenced in the `<setup>` element.

Attributes none

Sample `<size>20</size>`

`<fontcolor></fontcolor>`

Description This element wraps around the font colour elements (`<alpha>`, `<red>`, `<blue>`, `<green>`) of the current subtitle. This value is overridden if a valid text setup file is referenced in the `<setup>` element.

Attributes `<alpha></alpha>`
The `<alpha>` colour component of the font of the current subtitle. This value is overridden if a valid text setup file is referenced in the `<setup>` element.
`<red></red>`
The `<red>` colour component of the font of the current subtitle. This value is overridden if a valid text setup file is referenced in the `<setup>` element.
`<green></green>`
The `<green>` colour component of the font of the current subtitle. This value is overridden if a valid text setup file is referenced in the `<setup>` element.
`<blue></blue>`

The `<blue>` colour component of the font of the current subtitle. This value is overridden if a valid text setup file is referenced in the `<setup>` element.

Sample	<pre><fontcolor> <alpha>255</alpha> <red>255</red> <green>255</green> <blue>255</blue> </fontcolor></pre>
--------	-------------------------------------------------------------------------------------------------------------------------------------------------------------------------------

`<vertical></vertical>`

Description	The vertical text position of the current subtitle. This value is overridden if a valid text setup file is referenced in the <code><setup></code> element.
-------------	------------------------------------------------------------------------------------------------------------------------------------------------------------------

Attributes	none
------------	------

Sample	<pre><vertical>0</vertical></pre>
--------	-----------------------------------------------

`<horizontal></horizontal>`

Description	The horizontal text position of the current subtitle. This value is overridden if a valid text setup file is referenced in the <code><setup></code> element.
-------------	--------------------------------------------------------------------------------------------------------------------------------------------------------------------

Attributes	none
------------	------

Sample	<pre><horizontal>0</horizontal></pre>
--------	---------------------------------------------------

`<setup></setup>`

Description	The <code><setup></code> element can point to a text setup file from which font style and position parameters will be used. The parameters from the text setup file override corresponding elements within the current <code><title></code> element.
-------------	------------------------------------------------------------------------------------------------------------------------------------------------------------------------------------------------------------------------------------------------------------------

Attributes	none
------------	------

Sample	<pre><setup>/usr/discreet/pro- ject/test/text/paz.ttg</setup></pre>
--------	---------------------------------------------------------------------------------

Sample Code

The following is an example of Subtitle XML which creates three Soft Text effects applied to gaps at these timecodes:

- 01:00:01;00 until 01:00:02;00
- 01:00:03;00 until 01:00:04;00
- 01:00:05;00 until 01:00:06;02

```

<?xml version="1.0" encoding="UTF-8"?>
<!DOCTYPE subtitle>
<subtitle version="1">
  <name>SampleSubtitles</name>
  <!-- Rate should be one of : -->
  <!-- -->
  <!-- * '23.976'-->
  <!-- * '24'-->
  <!-- * '25'-->
  <!-- * '29.97 DF'-->
  <!-- * '29.97 NDF' -->
  <!-- * '30'-->
  <!-- * '59.94 DF'-->
  <!-- * '59.94 NDF' -->
  <rate>24</rate>
  <!-- Set width and height to default -->
  <!-- if you want project default res -->
  <!-- depth should be : -->
  <!-- -->
  <!-- * '8', '10' or '12'.-->
  <!-- * default : for project default depth -->
  <!-- aspect should be : -->
  <!------>
  <!-- * '1.77777'-->
  <!-- * '1.333'-->
  <!-- * default-->
  <!-- scanformat should be : -->
  <!------>
  <!-- * 'f1' -->
  <!-- * 'f2' -->
  <!-- * default-->
  <resolution>
    <width>1920</width>
    <height>1080</height>
    <depth>8</depth>
    <aspect>1.778</aspect>
    <scanformat>default</scanformat>
  </resolution>
  <timecode>
    <start>01:00:00;00</start>
    <end>01:00:08;00</end>
  </timecode>
</video>

```

```

<title>
  <start>01:00:01;00</start>
  <end>01:00:02;00</end>
  <text>This is a subtitle string</text>
  <font>Garamond</font>
  <size>20</size>
  <fontcolor>
    <alpha>255</alpha>
    <red>255</red>
    <green>255</green>
    <blue>255</blue>
  </fontcolor>
  <vertical>0</vertical>
  <horizontal>0</horizontal>
  <setup>/usr/discreet/project/test/text/paz.ttg</setup>
</title>
<title>
  <start>01:00:03;00</start>
  <end>01:00:04;00</end>
  <text>This is another subtitle string</text>
  <font>Garamond</font>
  <size>20</size>
  <fontcolor>
    <alpha>255</alpha>
    <red>255</red>
    <green>255</green>
    <blue>255</blue>
  </fontcolor>
  <vertical>100</vertical>
  <horizontal>100</horizontal>
  <setup>/usr/discreet/project/test/text/paz.ttg</setup>
</title>
<title>
  <start>01:00:05;00</start>
  <end>01:00:06;02</end>
  <text>This is a third subtitle string</text>
  <font>Garamond</font>
  <size>20</size>
  <fontcolor>
    <alpha>255</alpha>
    <red>255</red>
    <green>255</green>
    <blue>255</blue>

```

```
</fontcolor>
<vertical>-100</vertical>
<horizontal>-200</horizontal>
<setup>/usr/discreet/project/test/text/paz.ttg</setup>
</title>
</video>
</subtitle>
```

Importing AAF Files

21

Topics in this chapter:

- [About Importing Advanced Authoring Format Files](#) on page 481
- [Workflow](#) on page 482
- [Preparing Sequences Cut in Avid for AAF Import](#) on page 482
- [Importing AAF Files](#) on page 484
- [Relinking to File-based Media](#) on page 486
- [Optimizing the Recapture of Footage Referenced in AAF Files](#) on page 488
- [Supported and Unsupported Transitions and Effects](#) on page 489

About Importing Advanced Authoring Format Files

The Advanced Authoring Format (AAF) is a file format that represents a multi-layered timeline complete with transitions, as well as video and audio effects.

AAF files are similar to traditional EDLs, only they are more powerful because of their multi-layer support. AAF files, therefore, are even closer in composition to Final Cut Pro XML files.

Only AAF files exported from Avid editing applications are supported for import into Flame. As well, only the metadata in AAF files can be transferred, not the media itself. Media can be recaptured and/or relinked from the imported AAF file.

Additionally, only select transitions and effects are supported when importing an AAF file to Flame.

You can also load AAF made from Varicam content.

Workflow

First, prepare the sequences in your Avid application that will be exported as AAF. These sequences are then imported into Flame to be worked on in a timeline.

- 1 Do one of the following:
 - If you are editing from tape, perform logging and capture from a VTR in the Avid application. See [Logging and Capturing from Tape in Avid](#) on page 483.
 - If you are editing from files, verify that the supported media specifications and network configuration links are still valid for accessing the file-based media. See [Relinking to File-based Media](#) on page 486.
- 2 Edit and add effects/transitions in your Avid application. See [Supported and Unsupported Transitions and Effects](#) on page 489.
- 3 Export AAF sequences from Avid applications. See [Exporting Sequences from Avid](#) on page 483.
- 4 Import AAF from the Interchange menu, then recapture or relink the media. See [Importing AAF Files](#) on page 484.
- 5 Work on the recaptured project and/or finish it for final output.

Preparing Sequences Cut in Avid for AAF Import

Prepare sequences in your Avid application before exporting them as AAF files. If you are working from tapes, log and capture to Avid in a manner that will allow the online editor to easily recapture media in Flame. You should also be able to edit in Avid using file-based media.

TIP You can use both tape-based and file-based media in the same Avid project, and the media can be recaptured and relinked later in Flame.

You can load AAF files using the Interchange commands and either capture the source material from tape or relink the media to files.

Logging and Capturing from Tape in Avid

When capturing clips for offline edit sessions in Avid applications, you enter the tape name in the Tape Name field of the Capture Tool box. After importing the AAF in Flame, you recapture all the media from tape. It is this tape name, as entered in the Tape Name in Avid, that will indicate which tapes to use.

The following resolutions/framerates are supported for footage destined for Flame:

- | | | |
|----------------|------------------|-----------------|
| ■ NTSC@23.976 | ■ NTSC@29.97 | ■ PAL@24 |
| ■ PAL@25 | ■ 720p24@23.976 | ■ 720p60@29.97 |
| ■ 720p60@59.94 | ■ 1080p24@23.976 | ■ 1080p24@24 |
| ■ 1080p25@25 | ■ 1080i50@50 | ■ 1080i60@59.94 |

Exporting Sequences from Avid

When you are ready to export projects from the Avid application, you must export each sequence separately as an AAF file, since Flame does not support Bins or Batch lists.

You can, however, export sequences which contain nested sequences and the nested sequences will be translated into containers in Flame.

Use commands in the Avid File menu to export AAF Interchange Format documents.

To export AAF from Avid:

- 1 Select a sequence in the Browser window that you want to export in an interchange format document.

NOTE If nothing is selected, the entire contents of the Browser are exported. However, Flame only supports AAF files with a single sequence of edited clips.

- 2 Choose File | Export | AAF.
- 3 In the Export As dialog box, click Options.

- 4 In the Options dialog box, click Export As and, from the drop-down list, select AAF.
- 5 Click Save.
- 6 In the Export As dialog box, click Save.

Importing AAF Files

Import AAF sequences from Avid in the same way that you import an EDL. Each AAF file corresponds to a sequence that can be opened in the timeline, including video and audio layers, and select transitions and effects. Some unsupported effects are marked with comments indicating what you have to rebuild in Flame based on the original offline edit.

Avid can support 720/24p, 720/30p, and 720/60p output from Varicam to create AAF files. The timecode of the source is always 59.94 but the timelines can be 24p, 30p, or 60p.

Flame has the ability to conform AAF (23.976/29.97/59.94) from Varicam material (23.976/29.97/30/59.94/60). Flame can also remove non-active frames when capturing Varicam media. The source material must be at the same framerate as the sequence (for example, 23.97 in a 23.97 sequence).

After importing an AAF file, you recapture the footage from the original tapes using the Recapture tool. You can also reload file-based media. Once all the media is captured or reloaded, it is relinked to the sequence.

When importing AAF files that were created in SD resolution and that need to be conformed in HD, you will need to reformat the clips. See [Reformatting Clips](#) on page 273.

A new reel with the AAF filename is created in the clip library for each imported AAF file. The assembled clip in the new reel has the same name as the original AAF sequence.

To import an AAF file:

- 1 In the Clip Library menu, from the Interchange Format box, select AAF.

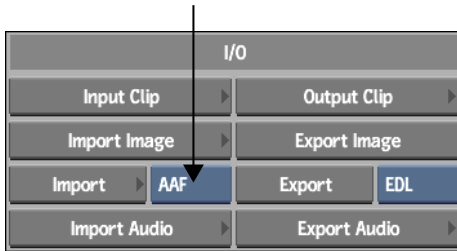

- 2 Click Import.
 - 3 In the file browser, navigate to an AAF file exported from an Avid application.
 - 4 Click Load.
- The Recapture menu appears.

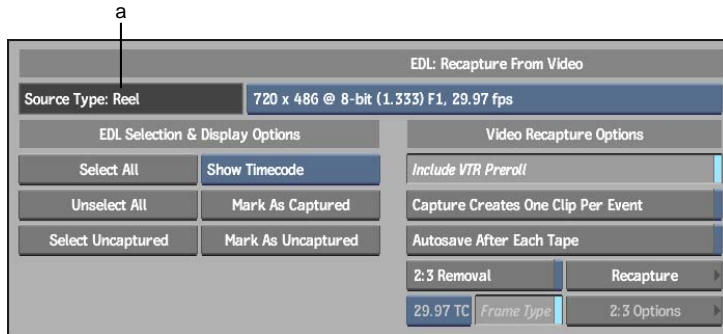

(a) Source Type box

If you edited with tapes in Avid, a list of source tapes in the tape list as previously logged, is displayed. In this case, the tape names correspond to the original names you entered in the Reel field for each clip.

If you edited with files in Avid, a list of files also appears in the Relink area of the Recapture menu. See [Relinking to File-based Media](#) on page 486.

If you are importing an AAF file with Varicam support, it will be identified as such in the Source Type box.

To recapture media from tape:

- 1 Recapture all the source material from the original sources as indicated in the tape list. For the necessary procedures, see [Recapturing Media](#) on page 280.

NOTE If your assembled clip references media that has already been recaptured, the material does not have to be recaptured again. As well, it is recommended to consolidate clips before recapturing. See [Optimizing the Recapture of Footage Referenced in AAF Files](#) on page 488.

After recapturing and relinking the sequence, exit the Recapture module to see the clip in the current clip library. A new reel appears in the library. This reel is named the same as the AAF file with the added suffix *AAF Import*. Within the reel, the clip assembled from the AAF is named the same as the sequence in Avid.

NOTE If you load AAF files with the same name, the clips that are created from them are added to the same reel.

You can load the reassembled clip into the timeline and proceed to tweak the effects added in the Avid application.

Relinking to File-based Media

If you edited sequences using file-based media, such as QuickTime movies, then you can relink the exported AAF to these files in Flame.

The files can be on local or remote storage. You can use Wiretap to relink the imported AAF file to media stored on different filesystems as long as they are accessible on the network.

Verify that the media files you are relinking to are supported in Flame. See [Supported File Formats](#) on page 194.

Relinking to Files on Different Computers Using Wiretap

When loading AAF files that you want to relink to file-based media, you can use Wiretap to access these files if they are stored on different computers.

The Wiretap Server must be configured properly to recognize the different hosts that you want to retrieve media from.

To relink to files using Wiretap:

- 1 In the Clip Library menu, from the Interchange Format box, select AAF, and click Import.
- 2 Enter the host or group name, as configured in the *sw_wiretap_path_translation_db.xml* file.

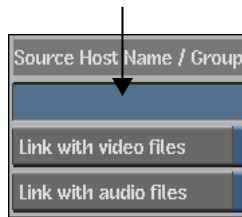

When loading AAF files, the file-based media can be retrieved from the host or group you indicate. The host or group name is resolved from the configuration in the *sw_wiretap_path_translation_db.xml* file. See the *Autodesk Stone and Wire Filesystem and Networking Guide* or contact your Wiretap administrator.

- 3 Load the AAF file, then relink to media files. See [Relinking to File-based Video or Audio Media](#) on page 487.

If you do not enter a value in the Source Host Name / Group field, any paths contained in the AAF file will be interpreted as pointing to your Flame workstation rather than the correct location on another computer.

Relinking to File-based Video or Audio Media

You can relink imported AAF files to file-based video or audio media that have the same resolution as the sequence to relink.

To relink AAF files to file-based media:

- 1 In the Clip Library menu, from the Interchange Format box, select AAF, and click Import.
- 2 Enable the Link with video files and/or Link with audio files buttons.

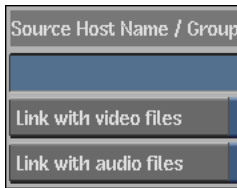

3 Click Load.

The Recapture menu appears with a list of files and paths in the Relink area.

If there are segments in the AAF file that were captured from tape, these also appear in the Tape List.

If you are importing AAF with Varicam support it will be identified as such in the Source Type box.

4 Reload the file-based media to the imported AAF file. See [Reloading Imported Files](#) on page 284.

Optimizing the Recapture of Footage Referenced in AAF Files

There are two methods that can help you achieve a more efficient workflow as you import projects from third parties via AAF. You can consolidate clips before recapturing to reduce the amount of extra footage, or you can relink clips to already captured media if multiple AAF files use the same footage.

Consolidating Clips in Flame

After importing an AAF file and prior to recapturing it, it is strongly recommended to consolidate your clip in Flame. This ensures that you do not capture all the extra media that was likely captured during the offline edit. This step should be performed even if a similar process was performed in the Avid application.

You can consolidate clips in the clip library. See [Consolidating Clips](#) on page 311.

In general, it is recommended to use the All Tracks option, available from the Consolidate option box, to consolidate all segments of an unlinked clip.

Relinking to Already Captured Material

If you import multiple AAF files that reference the same footage, you do not have to recapture the footage each time. Instead, you can relink the clip to media on the same reel.

To relink an imported AAF file to already recaptured clips:

- 1 After importing an AAF file, change the Library Reel to the reel where the media is located.

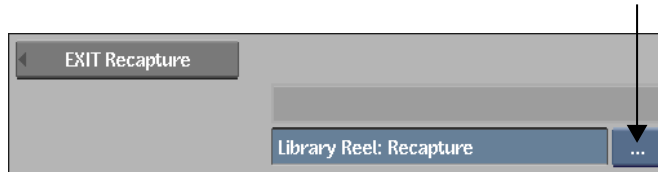

- 2 Click Relink.
The clip is linked to media on the reel that is referenced in the AAF file.
- 3 If necessary, recapture any missing media. See [Recapturing Media](#) on page 280.

Supported and Unsupported Transitions and Effects

The information in this section indicates how AAF data, transitions, and effects map to Flame data, transitions, and effects. There are three levels of support that can be indicated for each:

- **Translated:** Parameters from the AAF file are read and translated as Flame Soft Effect Parameters.
- **Converted:** The effect type is converted without parameters from the AAF file to a Flame Soft Effect or Transition. Some effects are recreated with a similar effect. Some are only recreated as an empty effect.
- **Not supported:** The effect is not supported and replaced by a comment or by a default transition or effect.

In addition, the following restrictions must also be taken into account:

- Only flattened Photoshop (.psd) files are supported (layered files will be imported as flattened in Flame).

- Only RGB material is supported, not RGBA.
- Graphics files of resolutions bigger or smaller than the timeline are imported as Center/Crop mode only.
- AAF files that contain MP3 media files cannot be relinked on Flame for Linux, since the MP3 file format is not supported on Linux.
- Nested effects are not supported.
- All video and audio tracks for each sequence must be imported.

General

The following tables describe how metadata and media are supported in Flame.

Metadata

Avid	Flame
All Video / Audio tracks	All Video / Audio tracks
Tape name	Tape name data
Source / Record Timecode	Source / Record Timecode
Drop / Non-Drop Timecode	Drop-Frame / Non-Drop-Frame
Mark In / Out	Not supported
Keycode	Supported
Video locator	Cue mark with locator text (no text data is translated)
23.976 / 29.97 timecode	23.976 / 29.97 timecode data provided (24p sequences are 23.976 for REC and 29.97 for SRC)

Media Import

Avid	Flame
Video media (JPEG, TIFF, etc.)	Paths and filenames translated
Audio media (WAV, AIFF)	Paths and filenames translated

Avid	Flame
Embedded/Linked Video media data (OMF, MXF)	Not supported
Embedded/Linked Audio media data (WAV, AIFF)	Not supported

Media Export

Avid	Flame
Video media (OMF, MXF)	Not supported
Audio media (WAV, AIFF)	Not supported

Sequence

Avid	Flame
Video only	Video-only sequence
Audio only	Audio-only sequence
Video and audio	Video and Audio sequence

Video and Audio Transitions

The following tables describe how transitions are supported in Flame.

Transitions marked with an * are also supported with the “Inverse” option set.

Blend

Avid	Flame
Dip to colour	Translated to Dissolve with colour data value
Dissolve	Converted to Dissolve (linear animation)
Fade from colour	Not supported; replaced by Dissolve + cue mark
Fade to colour	Not supported; replaced by Dissolve + cue mark

Avid	Flame
Picture-in-picture	Not supported; replaced by Dissolve + cue mark

Film	
Avid	Flame
Film dissolve	Converted to Dissolve (hermite animation)
Film fade	Converted to Dissolve (linear animation)

Box wipe	
Avid	Flame
Bottom box*	Converted to SMPTE 025
Bottom left to top right*	Converted to SMPTE 006
Bottom right to top left*	Converted to SMPTE 005
Left box*	Converted to SMPTE 026
Right box*	Converted to SMPTE 024
Top box*	Converted to SMPTE 023
Top left to bottom right*	Converted to SMPTE 003
Top right to bottom left*	Converted to SMPTE 004

Edge Wipe	
Avid	Flame
Horizontal*	Converted to SMPTE 001
Horz open*	Converted to SMPTE 021
Bottom left diagonal*	Converted to SMPTE 042 (animation is inverted)
Bottom right diagonal*	Converted to SMPTE 041 (animation is inverted)
Upper left diagonal*	Converted to SMPTE 041
Upper right diagonal*	Converted to SMPTE 042

Avid	Flame
Vert open*	Converted to SMPTE 022
Vertical*	Converted to SMPTE 002

Shape Wipe

Avid	Flame
4 corners*	Converted to SMPTE 007
Horizontal bands	Not supported; replaced by Dissolve + cue mark
Horizontal blinds	Not supported; replaced by Dissolve + cue mark
Vertical blinds	Not supported; replaced by Dissolve + cue mark
Center box*	Converted to SMPTE 101
Circle*	Converted to SMPTE 119
Ellipse*	Converted to SMPTE 120
Clock*	Converted to SMPTE 201
Diamond*	Converted to SMPTE 102

Sawtooth Wipe

Avid	Flame
Horizontal sawtooth*	Converted to SMPTE 071
Horz open sawtooth*	Converted to SMPTE 073
Vert open sawtooth*	Converted to SMPTE 074
Vertical sawtooth*	Converted to SMPTE 072

Matrix Wipe

Avid	Flame
Grid*	Not supported; replaced by SMPTE 008
One-way row	Not supported; replaced by SMPTE 001 + comment

Avid	Flame
Speckle	Not supported; replaced by SMPTE 001 + comment
Spiral	Not supported; replaced by SMPTE 001 + comment
Zig-zag	Not supported; replaced by Cue mark

Xpress 3D Effect

Avid	Flame
3D ball	Not supported; replaced by Cue mark
3D page fold	Not supported; replaced by Cue mark
3D slats	Not supported; replaced by Cue mark
3D PIP	Translated to Soft Axis (Position / Scaling (ISO, Softness / Crop))

Miscellaneous

Avid	Flame
Conceal	Converted to Soft Axis (Conceal effect)
L-Conceal	Converted to Soft Axis (L-Conceal effect)
Squeeze	Converted to Soft Axis (Squeeze effect)
Peel	Not supported; replaced by Dissolve + cue mark
Push	Not supported; replaced by Dissolve + cue mark
Spin	Not supported; replaced by Dissolve + cue mark
Video gap	Video gap
Video filler	Video gap
Video match frame edit	Match frame

Video and Audio Effects

The following tables describe how effects are supported in Flame.

Blend

Avid	Flame
Picture-in-picture	Translated to Soft Axis (Position / Scaling (ISO*))
Superimpose	Translated to Soft Blend (transparency value is translated)

NOTE Scaling in AAF can be X and Y. Flame only supports one value (X or Y) for both.

Film

Avid	Flame
1.66 mask	Not supported; replaced by Cue mark
1.85 mask	Not supported; replaced by Cue mark
16:9 mask	Not supported; replaced by Cue mark
Anamorphic mask	Not supported; replaced by Cue mark
Blowup	Not supported; replaced by Cue mark

AVX Plugin

Avid	Flame
Illusion FX	Not supported; replaced by Cue mark
AVX Plugins	Not supported; replaced by Cue mark

Image

Avid	Flame
Avid Pan and Zoom	Not supported; replaced by Cue mark
Blur effect	Not supported; replaced by Cue mark
colour Correction	Converted to Soft CC (empty) + cue mark

Avid	Flame
colour Effect	Converted to Soft CC (empty) + cue mark
Flip	Converted to Soft Axis (Flip effect)
Flip-flop	Converted to Soft Axis (Flip-flop effect)
Flop	Converted to Soft Axis (Flop effect)
Mask	Not supported; replaced by Cue mark
Reformat	Not supported; replaced by Cue mark
Resize	Translated to Soft Axis (Position / Scale values are translated)
Scratch removal	Not supported; replaced by Cue mark
Submaster	Converted to Container
Key	
Avid	Flame
Animate	Not supported; replaced by Cue mark
Chroma key	Converted to Soft Axis (empty)
Luma key	Converted to Soft Axis (empty)
Matte key	Converted to Soft Axis (empty)
RGB keyer	Not supported; replaced by Cue mark
Miscellaneous	
Avid	Flame
Timewarp	Converted to Soft TW (no keyframe data, but the In/Out and duration are correct; recreate the animated timewarp)
Motion Effect	Translated to Soft TW (Constant speed)
3D PIP	Translated to Soft Axis (Position / Scaling (ISO, Softness / Crop))

Avid	Flame
Peel	Not supported; replaced by Dissolve + cue mark
Push	Not supported; replaced by Dissolve + cue mark
Spin	Not supported; replaced by Dissolve + cue mark
Squeeze	Not supported; replaced by Dissolve + cue mark
Text tool	Not supported; replaced by a Virtual source for the duration of the effect + Cue mark
Video gap	Video gap
Video filler	Video gap
Video match frame edit	Match frame

General Audio

Avid	Flame
Audio level	Audio gain
Audio dissolve	Audio dissolve
Audio fade in	Audio dissolve
Audio fade out	Audio dissolve
Audio gap	Audio gap
Audio filler	Audio gap
Audio match frame edit	Match frame splice

Audio Suite Plugin

Avid	Flame
Chorus	Not supported; replaced by Cue mark
D-verb	Not supported; replaced by Cue mark
Compressor	Not supported; replaced by Cue mark

Avid	Flame
Limiter	Not supported; replaced by Cue mark
Expander-gate	Not supported; replaced by Cue mark
Gate	Not supported; replaced by Cue mark
DeEsser	Not supported; replaced by Cue mark
1-band EQII	Not supported; replaced by Cue mark
4-band EQII	Not supported; replaced by Cue mark
Flanger	Not supported; replaced by Cue mark
Invert	Not supported; replaced by Cue mark
Duplicate	Not supported; replaced by Cue mark
Delay	Not supported; replaced by Cue mark
Multi-tap delay	Not supported; replaced by Cue mark
Normalize	Not supported; replaced by Cue mark
Gain	Not supported; replaced by Cue mark
Ping-pong delay	Not supported; replaced by Cue mark
Reverse	Not supported; replaced by Cue mark
DC offset removal	Not supported; replaced by Cue mark
Signal generator	Not supported; replaced by Cue mark
Time compression exp	Not supported; replaced by Cue mark
Pitch shift	Not supported; replaced by Cue mark

Importing and Exporting OMF Files

22

Topics in this chapter:

- [About OMF Files](#) on page 499
- [OMF Project Workflow](#) on page 500
- [Importing OMF Files](#) on page 500
- [Exporting OMF Files](#) on page 502
- [Supported and Unsupported Transitions and Effects](#) on page 504

About OMF Files

Open Media Framework® (OMF®) Interchange® files make it possible to move projects with multiple video and audio tracks between systems. You can even include embedded audio media in the OMF file to facilitate the process of restoring a project on another system.

An OMF file is like an EDL with expanded capabilities. Essentially, you use an OMF file to recreate a timeline with all the tracks, effects, and events intact.

Without the benefit of an OMF file, moving a project can be a difficult process, particularly between different editing systems. For instance, when using EDLs to recreate your editing decisions, most formats support only one video track and up to four audio tracks per EDL. If your project contains multiple video

and audio tracks, you must create several sets of EDLs, and label each carefully to ensure that they are reassembled in the right order. Information about effects must be manually entered to be included in the EDL.

However, with OMF files, the timeline track and event structure is stored so that it can be rebuilt on another system. The audio media itself can even be included in the OMF file.

When you want to move a project with multiple tracks and effects, use the OMF import or export tools.

OMF Project Workflow

The following typical workflow illustrates how OMF files are used to move timeline metadata and audio media between systems at various stages in the post-production process.

- 1 Create an offline editing project using any Avid® offline editing application and export an OMF file with included audio media.
- 2 Import the OMF file into Flame and recapture the media.
- 3 Finish in Flame and perform any sound mixing.
- 4 If you want to use another audio tool such as Pro Tools® to complete the audio mix, then do the following:
 - Export the final timeline as an OMF file (with audio media).
 - Import the new OMF file into Digidesign Pro Tools® and complete the audio mix.
 - From Pro Tools, export the finished audio as WAV or AIFF.
 - Import the finished audio into Flame and recombine it in the final timeline.
- 5 From Flame, output to tape or export to another format.

Importing OMF Files

You can import an OMF file to the Desktop to recreate the original video and audio track structure. Audio files embedded in the OMF file are imported into Flame as clips. The audio does not need to be recaptured.

OMF files from the following applications are supported:

- Avid® Media Composer®
- Avid Symphony™
- Avid Xpress® PRO
- Avid Xpress DV

Only the EDL information (such as dissolve, timecode, tape name) and the audio media is supported (AIFF-C and WAV). No audio effects are translated (for example, audio gain, plug-ins).

When you import an OMF file with embedded audio media, the extracted audio files are saved in a new folder (with the OMF file name) located in the project EDL folder. Because audio media can take up a lot of space on the system drive, make sure that you manage the audio files and remove them after the project is done. The clips can be unlinked and relinked.

When importing OMF files created by third-party applications, the supported embedded sampling rates are 44.1 KHz and 48 KHz. Other sampling rates must be converted before the OMF file is created.

The supported resolution / framerates are NTSC 29.97 and PAL 25.

Source clips without tape names will be assigned IMPORT as a tape name.

To import an OMF file:

- 1 In the Clip Library menu, from the Interchange Format box, select OMF.

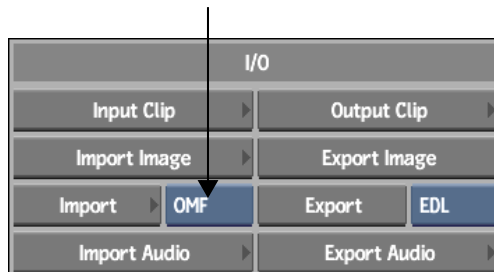

- 2 Click Import.
- 3 In the file browser, navigate to the OMF file.
- 4 Click Load.

The OMF file is loaded to the EDL module. EDLs are created for each track and layer in the OMF file. In addition, the audio media is extracted from

the OMF file and placed in a temporary location. See [About the Import EDL Menu](#) on page 322.

- 5 Select the events in the EDL module that reference audio media and click Import.

The audio media is imported as clips in the clip library.

Once the EDLs are in the EDL module, you assemble the EDLs as you would any other EDL. See [Assembling EDLs](#) on page 386.

Exporting OMF Files

When you export a clip as an OMF file, the file is saved in a directory in the filesystem. You can load an OMF file from the directory into another application, or transfer it to another platform.

To complete a project, you can also export an edited clip to an OMF file with embedded audio media. That way, any audio finishing systems supporting OMF format can read the file. Audio-only information and audio media is exported. You should limit the size of an exported file to 2 gigabytes.

The following applications can read an OMF file exported from Flame:

- Avid Media Composer
- Avid Xpress DV
- Digidesign® Pro Tools
- Fairlight AV Transfer
- Neve AMS
- Avid Symphony
- Avid Xpress PRO
- Steinberg Nuendo
- Cubase™
- Merging Pyramix

The following information is exported:

- Clips with multiple audio tracks
- Cuts and linear dissolves
- Up to 8 audio tracks per file
- Audio patching information

The following information is not exported:

- Video tracks
- Audio soft effects
- EQ Desk settings
- Audio animation
- AudioDesk settings
- Audio timestretch

In addition, the following restrictions must also be taken into account:

- Before exporting, make sure that the source tape name or timecode is unique.
- Subframe editing is not supported. Subframes will create offsets in the exported OMF files.

To export an OMF file:

- 1 In the clip library, select the clip or clips that you want to export.
- 2 In the Clip Library menu, from the Export Interchange Format box, select OMF.



- 3 Click Export.
The Export EDL menu appears.



(a) Track table (b) Clip List (c) Audio Sample Rate box (d) Limit Handles field

- 4 Select the clip to export in the Clip List.

- 5 Enable the tracks to export in the Track table. See [Track Table](#) on page 395.
- 6 Optional: enable Generate Audio Media.
The audio is saved as a separate file.
- 7 Optional: enable Limit Handles to export the source clip with a specified maximum number of frames before and after the edit.
Enter a value for the number of frames used before and after the edit in the Limit Handles field.
- 8 Click Generate.
The file browser appears.
- 9 Specify the location of the exported file and the filename, and then click Save.

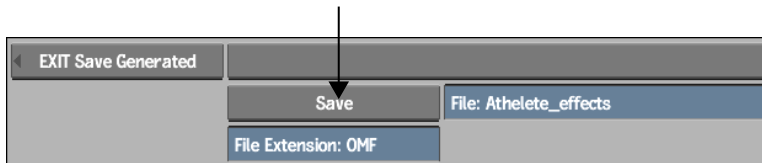

NOTE To avoid file name compatibility issues upon export, underscores will be substituted in your file name in place of any of the following characters:
` # ~ @ \$ % ^ & * () [] { } < > \ | / ! ? , ; : ' " "

The OMF file is exported to the specified location.

Supported and Unsupported Transitions and Effects

The following sections describe how Flame translates the video contents of an imported OMF file into clips.

Supported Decisions and Transitions

The OMF Converter Utility translates the following information:

- Clips on multiple video and audio tracks
- Cuts and dissolves
- Speed changes

- Clip and subclip names
- Audio patching information
- Wipe transitions (As available in Flame. See [Transitions Translation](#) on page 505.)
- Wipe effects (As available in Flame. See [Effects Translation](#) on page 510.)

The information in this section describes how OMF transitions and effects map to Flame transitions and effects. There are two levels of support that can be indicated for each:

- The effects are translated without effect parameters. A default effect is applied.
- The effects are ignored if they cannot be translated into Flame.

Transitions Translation

Avid transitions are translated as follows when importing an OMF file into Flame.

Blend

Avid	Flame
Dip to Color	Dissolve (no colour information)
Dissolve	Dissolve
Fade From Color	Dissolve (no colour information)
Fade to Color	Dissolve (no colour information)
Picture-in-Picture	Not supported
Superimpose	Not supported; replace by SMPTE WIPE 001

Box Wipes

Avid	Flame
Bottom Box	SMPTE WIPE 025

Avid	Flame
Bottom Left to Top Right	SMPTE WIPE 006
Bottom Right to Top Left	SMPTE WIPE 005
Left Box	SMPTE WIPE 026
Right Box	SMPTE WIPE 024
Top Box	SMPTE WIPE 023
Top Left to Bottom Right	SMPTE WIPE 003
Top Right to Bottom Left	SMPTE WIPE 004

Conceal

Avid	Flame
Bottom Left to Top Right	Not supported; replace by SMPTE WIPE 001
Bottom Right to Top Left	Not supported; replace by SMPTE WIPE 001
Bottom to Top	Not supported; replace by SMPTE WIPE 001
Left to Right	Not supported; replace by SMPTE WIPE 001
Right to Left	Not supported; replace by SMPTE WIPE 001
Top Left to Bottom Right	Not supported; replace by SMPTE WIPE 001
Top Right to Bottom Left	Not supported; replace by SMPTE WIPE 001
Top to Bottom	Not supported; replace by SMPTE WIPE 001

Edge Wipes

Avid	Flame
Horizontal	SMPTE WIPE 002
Horizontal Open	SMPTE WIPE 022
Lower Left Diagonal	SMPTE WIPE 042
Lower Right Diagonal	SMPTE WIPE 041

Avid	Flame
Upper Left Diagonal	SMPTE WIPE 041
Upper Right Diagonal	SMPTE WIPE 042
Vert Open	SMPTE WIPE 021
Vertical	SMPTE WIPE 001

L-Conceal

Avid	Flame
Bottom Left	Not supported; replace by SMPTE WIPE 001
Bottom Right	Not supported; replace by SMPTE WIPE 001
Top Left	Not supported; replace by SMPTE WIPE 001
Top Right	Not supported; replace by SMPTE WIPE 001

Matrix Wipes

Avid	Flame
Grid	SMPTE WIPE 008
One-Way-Row	Not supported; replace by SMPTE WIPE 001
Speckle	Not supported; replace by SMPTE WIPE 001
Spiral	Not supported; replace by SMPTE WIPE 001
Zig Zag	Not supported; replace by SMPTE WIPE 001

Peel

Avid	Flame
Bottom Left Corner	Not supported; replace by SMPTE WIPE 001
Bottom Right Corner	Not supported; replace by SMPTE WIPE 001
Left To Right	Not supported; replace by SMPTE WIPE 001
Right to Left	Not supported; replace by SMPTE WIPE 001

Avid	Flame
Top Left Corner	Not supported; replace by SMPTE WIPE 001
Top Right Corner	Not supported; replace by SMPTE WIPE 001
Top to Bottom	Not supported; replace by SMPTE WIPE 001

Push

Avid	Flame
Bottom Left to Top Right	Not supported; replace by SMPTE WIPE 001
Bottom Right to Top Left	Not supported; replace by SMPTE WIPE 001
Bottom to Top	Not supported; replace by SMPTE WIPE 001
Left to Right	Not supported; replace by SMPTE WIPE 001
Right to Left	Not supported; replace by SMPTE WIPE 001
Top Left to Bottom Right	Not supported; replace by SMPTE WIPE 001
Top Right to Bottom Left	Not supported; replace by SMPTE WIPE 001
Top to Bottom	Not supported; replace by SMPTE WIPE 001

Sawtooth Wipes Transitions

Avid	Flame
Horizontal Sawtooth	SMPTE WIPE 074
Horizontal Open Sawtooth	SMPTE WIPE 072
Vertical Open Sawtooth	SMPTE WIPE 071
Vertical Sawtooth	SMPTE WIPE 073

Shape Wipes Transitions

Avid	Flame
4 Corners	SMPTE WIPE 007
Center Box	SMPTE WIPE 101

Avid	Flame
Circle	SMPTE WIPE 119
Clock	SMPTE WIPE 201
Diamond	SMPTE WIPE 102
Ellipse	SMPTE WIPE 120
Horizontal Bands	Not supported; replace by SMPTE WIPE 001
Horizontal Blinds	Not supported; replace by SMPTE WIPE 001
Vertical Blinds	Not supported; replace by SMPTE WIPE 001

Spin Transitions

Avid	Flame
X Spin	Not supported; replace by SMPTE WIPE 001
Y Spin	Not supported; replace by SMPTE WIPE 001
Z spin	Soft Axis (Z spin Effect)

Squeeze Transitions

Avid	Flame
Bottom Centered	Not supported; replace by SMPTE WIPE 001
Bottom Left	Not supported; replace by SMPTE WIPE 001
Bottom Right	Not supported; replace by SMPTE WIPE 001
Bottom to Top	Not supported; replace by SMPTE WIPE 001
Centered Zoom	Not supported; replace by SMPTE WIPE 001
Horizontal Centered	Not supported; replace by SMPTE WIPE 001
Left To Right	Not supported; replace by SMPTE WIPE 001
Right Centered	Not supported; replace by SMPTE WIPE 001
Right to Left	Not supported; replace by SMPTE WIPE 001

Avid	Flame
Top Centered	Not supported; replace by SMPTE WIPE 001
Top Left	Not supported; replace by SMPTE WIPE 001
Top Right	Not supported; replace by SMPTE WIPE 001
Top to Bottom	Not supported; replace by SMPTE WIPE 001
Vertical Centered	Not supported; replace by SMPTE WIPE 001

Effects Translation

Flame does not support Timewarp effects in OMF files. These effects are converted to a linear Timewarp. The resulting timeline will have the correct duration with the correct Source In/Out timecode, but the speed will be incorrect. You will need to manually replicate the animation Timewarp effect.

Audio EQ is not supported if you import an OMF file with EQ. The audio clip on which the EQ effect was applied will be replaced with a gap. The remainder of the OMF file will be loaded correctly.

Wipes imported through OMF as effects are always animated.

Avid effects are translated as follows when importing an OMF file into Flame.

Blend

Avid	Flame
Picture-in-Picture	Soft Axis (50% scale down)
Superimpose	Soft Blend (50% blend)

Box Wipes

Avid	Flame
Bottom Box	Not supported; replace by SMPTE WIPE 001
Bottom Left to Top Right	Not supported; replace by SMPTE WIPE 001
Bottom Right to Top Left	Not supported; replace by SMPTE WIPE 001
Left Box	Not supported; replace by SMPTE WIPE 001

Avid	Flame
Right Box	Not supported; replace by SMPTE WIPE 001
Top Box	Not supported; replace by SMPTE WIPE 001
Top Left to Bottom Right	Not supported; replace by SMPTE WIPE 001
Top Right to Bottom Left	Not supported; replace by SMPTE WIPE 001

Conceal

Avid	Flame
Bottom Left to Top Right	Soft Axis (Bottom Left to Top Right)
Bottom Right to Top Left	Soft Axis (Bottom Right to Top Left)
Bottom to Top	Soft Axis (Bottom to Top)
Left to Right	Soft Axis (Left to Right)
Right to Left	Soft Axis (Right to Left)
Top Left to Bottom Right	Soft Axis (Top Left to Bottom Right)
Top Right to Bottom Left	Soft Axis (Top Right to Bottom Left)
Top to Bottom	Soft Axis (Top to Bottom)

Edge Wipes

Avid	Flame
Horizontal	SMPTE WIPE 001
Horizontal Open	SMPTE WIPE 021
Lower Left Diagonal	SMPTE WIPE 041
Lower Right Diagonal	SMPTE WIPE 042
Upper Left Diagonal	SMPTE WIPE 041
Upper Right Diagonal	SMPTE WIPE 042
Vert Open	Not supported; replace by SMPTE WIPE 001

Avid	Flame
Vertical	SMPTE WIPE 002

Film	
Avid	Flame
1:1.66 Mask	Soft Resize (1.66 Mask)
1:1.85 Mask	Soft Resize (1.85 Mask)
1:2.35 Mask	Soft Resize (2.35 Mask)
16 x 9 Mask	Soft Resize (1.77 Mask)
Blowup	Soft Resize (125% blowup)
Film Dissolve	Dissolve
Film Fade	Dissolve
MASK	Soft Axis (Default values)

Image	
Avid	Flame
Avid Pan & Zoom	Not supported
Color Correction	Not supported
Color Effect	Soft CC (Default Values)
Flip	Soft Axis (Flip effect)
Flip-Flop	Soft Axis (Flip-Flop effect)
Flop	Soft Axis (Flop effect)
Mask	Soft Resize
Region Stabilize	Unsupported
Resize	Soft Resize
Submaster	Container with Soft Effects

Key

Avid	Flame
AnimAtte	Not supported
Chroma Key	Soft Axis (Default RGB Key)
Luma Key	Soft Axis (Default LUM Key)
Matte Key	Soft Axis (Default Value)
RGB Keyer	Not supported

L-Conceal

Avid	Flame
Bottom Left	Not supported; replace by SMPTE WIPE 001
Bottom Right	Not supported; replace by SMPTE WIPE 001
Top Left	Not supported; replace by SMPTE WIPE 001
Top Right	Not supported; replace by SMPTE WIPE 001

Matrix Wipes

Avid	Flame
Grid	SMPTE WIPE 008
One-Way-Row	Not supported; replace by SMPTE WIPE 001
Speckle	Not supported; replace by SMPTE WIPE 001
Spiral	Not supported; replace by SMPTE WIPE 001
Zig Zag	Not supported; replace by SMPTE WIPE 001

Motion

Avid	Flame
0% to 100%	Not supported; replaced by a fit-to-fill soft TW from in & out material

Avid	Flame
100% to 0%	Not supported; replaced by a fit-to-fill soft TW from in & out material
Pulldown Insertion	Not supported; replaced by a fit-to-fill soft TW from in & out material
Pulldown Removal	Not supported; replaced by a fit-to-fill soft TW from in & out material
Reverse Motion	Not supported; replaced by a fit-to-fill soft TW from in & out material
Speed Boost	Not supported; replaced by a fit-to-fill soft TW from in & out material
Speed Bump	Not supported; replaced by a fit-to-fill soft TW from in & out material
Timewarp	Not supported; replaced by a fit-to-fill soft TW from in & out material

Peel

Avid	Flame
Bottom Left Corner	Not supported; replace by SMPTE WIPE 001
Bottom Right Corner	Not supported; replace by SMPTE WIPE 001
Left To Right	Not supported; replace by SMPTE WIPE 001
Right to Left	Not supported; replace by SMPTE WIPE 001
Top Left Corner	Not supported; replace by SMPTE WIPE 001
Top Right Corner	Not supported; replace by SMPTE WIPE 001
Top to Bottom	Not supported; replace by SMPTE WIPE 001

Push

Avid	Flame
Bottom Left to Top Right	Not supported; replace by SMPTE WIPE 001

Avid	Flame
Bottom Right to Top Left	Not supported; replace by SMPTE WIPE 001
Bottom to Top	Not supported; replace by SMPTE WIPE 001
Left to Right	Not supported; replace by SMPTE WIPE 001
Right to Left	Not supported; replace by SMPTE WIPE 001
Top Left to Bottom Right	Not supported; replace by SMPTE WIPE 001
Top Right to Bottom Left	Not supported; replace by SMPTE WIPE 001
Top to Bottom	Not supported; replace by SMPTE WIPE 001

Sawtooth Wipes

Avid	Flame
Horizontal Sawtooth	SMPTE WIPE 071
Horizontal Open Sawtooth	SMPTE WIPE 021
Vertical Open Sawtooth	Not supported; replace by SMPTE WIPE 001
Vertical Sawtooth	SMPTE WIPE 072

Shape Wipes

Avid	Flame
4 Corners	SMPTE WIPE 007
Center Box	SMPTE WIPE 101
Circle	SMPTE WIPE 119
Clock	SMPTE WIPE 201
Diamond	SMPTE WIPE 102
Ellipse	SMPTE WIPE 120
Horizontal Bands	Not supported; replace by SMPTE WIPE 001
Horizontal Blinds	Not supported; replace by SMPTE WIPE 001

Avid	Flame
Vertical Blinds	Not supported; replace by SMPTE WIPE 001

Spin	
Avid	Flame
X Spin	Not supported; replace by SMPTE WIPE 001
Y Spin	Not supported; replace by SMPTE WIPE 001
Z spin	Soft Axis (Z spin Effect)

Squeeze	
Avid	Flame
Bottom Centered	Soft Axis (Squeeze Bottom Centered)
Bottom Left	Soft Axis (Squeeze Bottom Left)
Bottom Right	Soft Axis (Squeeze Bottom Right)
Bottom to Top	Soft Axis (Squeeze Bottom to Top)
Centered Zoom	Soft Axis (Squeeze Centered Zoom)
Horizontal Centered	Soft Axis (Squeeze Horizontal Centered)
Left To Right	Soft Axis (Squeeze Left To Right)
Right Centered	Soft Axis (Squeeze Right Centered)
Right to Left	Soft Axis (Squeeze Right to Left)
Top Centered	Soft Axis (Squeeze Top Centered)
Top Left	Soft Axis (Squeeze Top Left)
Top Right	Soft Axis (Squeeze Top Right)
Top to Bottom	Soft Axis (Squeeze Top to Bottom)
Vertical Centered	Soft Axis (Squeeze Vertical Centered)

Text Tool

Text is unsupported. Text is replaced on the timeline by comments.

Part 5: Project and Media Management

Part 5 includes these chapters:

- [Managing Projects and Users](#) on page 521
- [Clip Libraries](#) on page 555
- [Archiving](#) on page 603



Image courtesy of Absolute Post

Managing Projects and Users

23

Topics in this chapter:

- [About Projects and Users](#) on page 521
- [Selecting a Project and User on Start-up](#) on page 525
- [Creating a Project](#) on page 526
- [Modifying a Project](#) on page 538
- [Deleting a Project](#) on page 539
- [Managing Proxies](#) on page 541
- [Auto-Connecting Clip Libraries Belonging to Other Projects](#) on page 545
- [Creating and Loading a User and Sharing User Preferences](#) on page 545
- [Modifying a User](#) on page 548
- [Deleting a User](#) on page 549
- [Loading Different Projects and Users during a Work Session](#) on page 551
- [About Multi-Format Projects](#) on page 552
- [Working with Remote Framestores](#) on page 552

About Projects and Users

Create projects and users to define your working environment in Flame. Projects define the display environment and provide a home directory where you keep

effects setups and other resources. Also, clip libraries, where clips are stored, are associated with projects.

Typically, each job you work on, you create a project. A project provides an organizational framework in which you can define graphics display parameters, manage media in clip libraries, and save and load file-based resources such as effects setups, EDLs, and LUTs.

For each person working on your system, you can also create a user. A user is a profile that maintains user interface preferences such as desktop layout and display options, pen and tablet preferences, as well as a personalized set of hot keys based on the default set.

Projects

In Flame, a project is a job-based working environment that provides:

- A Desktop and the means of creating clip libraries for media management
- Proxy management settings to store low-resolution proxies for high-resolution clips
- A display environment for playing back clips
- A filesystem environment (home directory) for managing resources such as LUTs, EDLs, and setups

You can edit a project's settings through the course of your job. A project is associated with a default resolution that incorporates frame width and height, aspect ratio, scan mode, and bit depth. Although the default resolution in no way restricts you from working with other resolutions, it does define default settings such as:

- The default resolution for the processing of coloured frames (for example, black frames, colour bars, and colour noise)
- The default destination resolution for all resize settings
- The default resolution for entering Paint or Text with the None option
- The default resolution for the processed result of Action composites, independent of the resolution of clips you use as media and as the background

When you set a default resolution, you usually select a project configuration template file that corresponds to that resolution. For example, if you set your

project's default resolution to NTSC, the *ntsc.cfg* project configuration template is usually used to create the configuration file for your project. The project configuration file sets environment display parameters such as monitor refresh rate and default timecode for clips.

This chapter describes how to select a default resolution and select a project configuration template. Remember, however, that all the parameters associated with a project's default resolution in no way restrict you from working with other resolutions. To learn about creating a project for use with clips of different resolutions, see [Working with Multi-Format Input and Output](#) on page 164.

Projects also provide a home directory on the system disk that contains sample setups and LUTs. These sample resources are situated in subdirectories for each module. Through the course of your project, you can save setups, EDLs, custom LUTs, and any other file-based resources in these directories. Because these directories are the default path for saving and loading resources such as effects setups, keeping files here accelerates your work.

Accessing Projects on Remote Framestores

You can access an Autodesk Visual Effects and Finishing project on a remote framestore from Flame. This is useful if you want to prepare a project already created in an Visual Effects and Finishing application for finishing but do not want to tie up system resources.

You can only access a remote framestore on start-up. If you try to access a remote project that is already open in Smoke, you will not have access to the project's Desktop, only to the project's clip library. This way you do not run the risk of overwriting someone's work or losing your own. Although the clip library will be read-only, you can navigate to other clip libraries belonging to the project and perform clip management operations.

NOTE It is important to understand that this functionality is not intended to allow collaborative and concurrent access to a central project from several remote workstations. A project remains tied to the workstation it is created on, and is meant for single-user access.

Sharing Projects between Autodesk Products

You can open projects created in Flame in other Autodesk Visual Effects and Finishing applications installed on your workstation. Projects created in all products are stored in a single directory — */usr/discreet/project*. The Project box in the start-up screen and in the Preferences menu list projects from both

product sets. The default project that appears in the list is the last one opened in either product type.

You can load and use projects in all products transparently with the exception of the clips on the EditDesk and desktop. When you use a project in both product sets, a separate desktop and EditDesk is stored for each. Therefore, the clips that you leave on the desktop in Inferno, Flame, or Flint for example, will not be accessible on the EditDesk when you load the project in Smoke or Backdraft Conform.

Users

A user is a profile that provides:

- Desktop display preferences
- Module preferences
- Hot key assignments for user interface controls
- A filesystem environment (home directory) for managing preferences

Your user profile is saved every time you switch to another user or exit Flame. User preferences are maintained independently of the projects that you are working on. By managing your own user, you can:

- Save Desktop preferences such as user interface, the number and orientation of desktop reels, as well as clip information display options. See [Setting Preferences](#) on page 827.
- Customize pen and tablet preferences such as pressure sensitivity and tablet margins. See [User Interface Preferences](#) on page 831.
- Modify default hot keys and create new ones using the Hot Key Editor. See [Managing Hot Keys](#) on page 863.
- Customize grids and guides for the Player and image window. See [Working with Grids and Guides](#) on page 116.
- Customize module-based preferences such as the colour of the crop box and object icon transparency to set up modules how you want. See [Saving Setups and Preferences](#) on page 799.

User preferences are maintained in the user home directory on the system disk.

Selecting a Project and User on Start-up

When you start Flame, the Project Management menu appears. Use the Project Management menu to select an existing project and user for the current session, to create new projects and users, or to manage existing projects and users. You can work with projects on the current framestore or on a remote framestore. If multiple partitions are available, you can select which one to use. For information on creating partitions, see the *Autodesk Stone and Wire Filesystem and Networking Guide*.

To select a project and user on start-up:

- 1 Log in to the Flame account and then double-click its icon on the desktop. After a few moments, the Project Management menu appears. The framestore, project, and user that were selected for the previous session appear in their respective boxes.

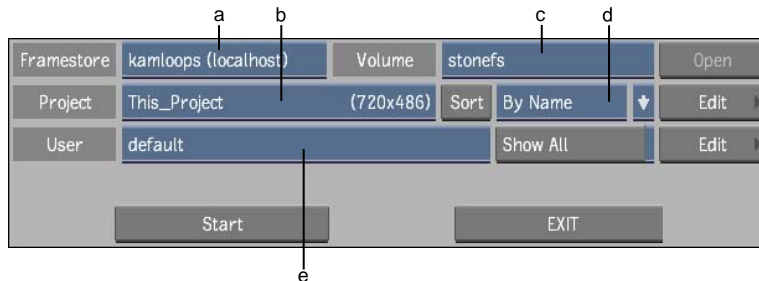

(a) Framestore box (b) Project box (c) Volume box (d) Sort Order box (e) User box

-
- 2 **NOTE** If this is the first time you are starting Flame, there are no existing projects (<new> is the only option), and the only user available is the default user.
-
- 3 Do one of the following:
 - To open a project from the current framestore, select a project from the Project box.
 - To open a project on a remote framestore, select the framestore from the Framestore box. If the framestore has more than one volume, select a volume from Volume box. Click Open, and then select a project from the Project box.

NOTE If you have a long list of projects to sort through, you can use the Sort Order box and arrow to sort the projects by frame resolution, name, or creation date, in descending or ascending order.

If you have not yet created a project for the current job, see [Creating a Project](#) on page 526.

- 4 From the User box, select your user profile.

If you have not yet created a user and do not want to use the default user, see [Creating and Loading a User and Sharing User Preferences](#) on page 545.

- 5 Click Start.

The project's Desktop appears. If you try to access a Smoke project that is already open on a remote framestore, an error message appears and you are asked to confirm whether you want to go into that project's clip library.

When the project loads, Flame attempts to select a VTR whose timing matches that of the project. The VTR devices available depend on the VTR keyword lines uncommented in the software initialisation configuration file. If multiple VTR matches are found in the list, Flame selects the first match. If no match is found, VTR selection reverts to "No VTR selected" with the appropriate timing. See [Flame Detection of Sync and Timing](#) on page 165.

Creating a Project

You can create a project on start-up from the Project Management menu or during a session from the Preferences menu.

To create a project:

- 1 Do one of the following:
 - If you are creating a project on start-up, select <new> from the Project box. (If you are starting Flame for the first time, <new> is the only option.)
To create a project on a remote framestore, select the framestore from the Framestore box. If the framestore has more than one volume, select a volume from the Volume box. Click Open, and then select <new> from the Project box.

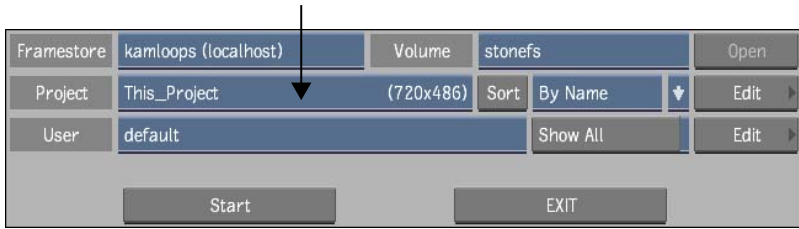

- If you are creating a project in the middle of a session (you are already on the Flame desktop), click Preferences and then select <new> from the Project box in the Project Management section of the Preferences menu.



The Create Project menu appears.

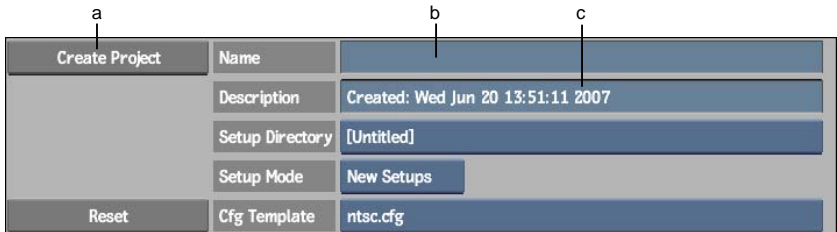

(a) Create Project button (b) Name field (c) Description field

- 2 In the Name field, enter a name for the new project. Names can be up to 120 characters long.
- 3 In the Description field, enter a description of the project.

TIP By default, the creation date is displayed in this field. Click the field to activate the text cursor, press **Esc** to clear the contents of the field, and then type the description that you want to use.

- 4 Set the home directory for the project. See [Setting a Project's Home Directory](#) on page 528.

- 5 Set the default resolution for the project. See [Setting the Default Resolution](#) on page 531.
- 6 Set proxy management options for the project. See [Setting Proxy Management Options](#) on page 532.
- 7 Set the scan mode for the project. See [Changing the Scan Mode of a Project](#) on page 721.
- 8 Select the graphics processing bit depth for the project, if applicable. See [Setting the Graphics Processing Bit Depth](#) on page 536.
- 9 Select a project configuration template for the project. See [Selecting the Project Configuration Template](#) on page 537.
- 10 To reset project settings, click Reset. You can edit a project's settings at any time.
- 11 When you are satisfied with project settings, click Create Project.
The project is created, and you are returned to the Project Management or Preferences menu.

TIP To exit the Create Project menu at any time without creating a project, click Exit Project.

Setting a Project's Home Directory

When you create a project, a project home directory is created on the system disk in the `/usr/discreet/project/` directory. File-based resources such as effects setups, EDLs, and LUTs are usually managed in a set of subdirectories in this home directory, by module.

For example, when you save an effects setup, the file browser opens by default to a subdirectory of the project home directory for setups related to the current module. You are not obliged to save setups in this directory, but doing so can help you better manage the resources you need by saving them to a consistent location. Similarly, when you load a setup, the file browser opens by default to the project's setup directory for the current module. For details on saving and loading setups into modules, see [Saving Setups and Preferences](#) on page 799.

You are not restricted to these directories when you load or save setups. You can use the file browser to locate a different directory, or use project shortcuts to browse the setup directories of other projects on the same system.

When you create a project, the project's home directory path appears in the Setup Directory box.



Create Project	Name	
	Description	Created: Wed Jun 20 13:51:11 2007
	Setup Directory	[Untitled]
	Setup Mode	New Setups
Reset	Cfg Template	rtsc.cfg

(a) Setup Directory box

You have two options, however, that override the default home directory:

- You can share the project home directory with an existing project, allowing you to share setups between the two projects.
- You can create a custom path for the project home directory.

You can also copy the setups of another project into the subdirectories of the project you are creating.

NOTE You can copy setups from a project created in a previous versions of Autodesk products to the new project — old projects are listed in the Copy From project list. However, you cannot share them.

To share the project home directory with an existing project:

- 1 From the Setup Directory box, select the existing project's home directory that you want to share.
Any setups already saved to the existing project are made available to the new project.

To create a custom path for the project's home directory:

- 1 From the Setup Directory box, select <new>.
- 2 In the file browser that appears, navigate to the directory where you want the project home directory created.
- 3 Make sure that the permissions in this directory are set so Flame (or the account into which you are logged in and from which you launched Flame) has read/write privileges.

- 4 Click New Directory.

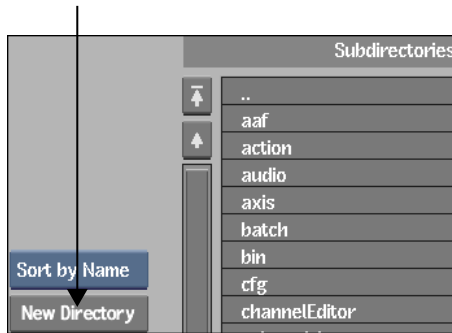

- 5 In the keyboard that appears, type the name of the project home directory in which you want Flame to create setup subdirectories and press **Enter**. It is recommended to give this directory the same name as the project.
If the directory is not created, you may not have the access privileges to create directories in the current location.
- 6 Click Set Directory.

The new directory name appears in the Setup Directory box of the Create Project menu.

To copy setups from an existing project:

- 1 From the Setup Mode box, select Copy From.

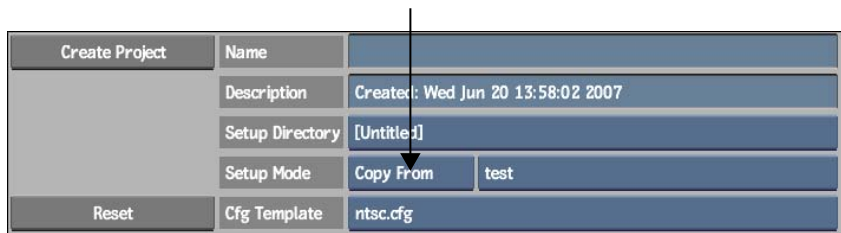

- 2 From the Projects box that appears to the right of the Setup Mode box, select the existing project from which you want to copy the setups.

Setting the Default Resolution

Setting the default resolution of a project involves selecting frame resolution, aspect ratio, bit depth, and scan mode.

NOTE IBM 6224 systems support a bit depth of 8 bits only.

To set the default resolution of the project:

- 1 From the Resolution Presets box, select an option.

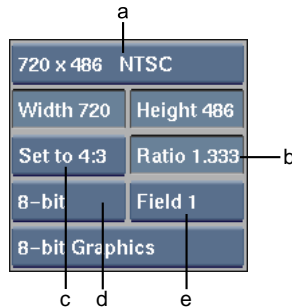

(a) Resolution Presets box (b) Aspect Ratio field (c) Aspect Ratio Presets box
(d) Bit Depth box (e) Scan Mode box

Alternatively you can set a custom resolution for the project by entering values in the Width and Height fields.

TIP When you select a resolution preset or enter a custom resolution, the Frames Free field is updated, indicating how many frames of the current resolution can be stored on the current framestore volume.

Although Flame supports mixed resolutions in each project, very large resolutions can only be manipulated on systems configured with at least 3.5 GB RAM. Exceeding this image size is possible but not recommended.

See the *Autodesk Visual Effects and Finishing Software Installation Guide* for minimum RAM recommendations for your workstation. If your system performs sluggishly when working with higher resolution images, consider installing more RAM.

Other resolution restrictions are as follows:

- At 8 bits, image width must be a multiple of four.
- At 10 bits or 12 bits, image width must be a multiple of two.

- The minimum image height is 24 pixels.

2 From the Aspect Ratio Presets box, select an option.

Select: **To:**

Set to w:h	Set the frame aspect ratio to match its width:height ratio. This option should be selected for square pixel formats. These formats include most film formats.
---------------	---------------------------------------------------------------------------------------------------------------------------------------------------------------

Set to 16:9	Set the frame aspect ratio to 16:9 (1.777). This option is used with most HD video formats, but occasionally with NTSC and PAL.
----------------	---------------------------------------------------------------------------------------------------------------------------------

Set to 4:3	Set the frame aspect ratio to 4:3 (1.333). This option is often used with NTSC and PAL.
---------------	-----------------------------------------------------------------------------------------

Alternatively you can set a custom aspect ratio by entering the decimal value for the ratio in the Aspect Ratio field. For example, enter 2.35 to set an environment for working with anamorphic film resolution images.

TIP When you select a Resolution preset, the aspect ratio is often updated with the setting that corresponds to the selected resolution.

3 Select a bit depth option from the Bit Depth box.

If you select 12-bit, each pixel occupies 36 bits on the framestore and requires processing to pack and unpack images as they move between memory and disk.

If you select 12-bit u (for 12-bit unpacked), each pixel occupies 48 bits on the framestore. Storage requirements are greater, but no processing is required as images move between memory and disk.

4 From the Scan Mode box, select Field 1, Field 2, or Progressive.

Flame supports clips with differing scan modes. This parameter sets the default project scan mode, which appears in various menus (for example, Resize) and is applied to newly processed clips. This setting affects interlaced display on a broadcast monitor and field-based render processes.

Setting Proxy Management Options

Proxies are low-resolution copies of high-resolution images, one for each frame. Set proxy management options to specify how and when proxies are generated for clips used in the project.

To set proxy management options:

- 1 From the Proxy Management option box, select an option.

TIP To change proxy management options for a current project, you must access the Project Management menu from the Preferences menu.

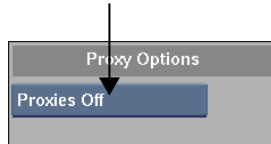

Select:	To store:
Proxies Off	No proxies, no matter what resolution clips you work with.
Proxies On	Proxies for all clips larger than the proxy width you set for all proxies.
Conditional	Proxies only for clips that meet conditional criteria, for example, clips that exceed a width of 1000 pixels.

- 2 If you selected Proxies On or Conditional, specify the proxy size by doing one of the following:
 - Select Fixed Width from the Proxy Size box and then enter a value in the Proxy Width field beside the Proxy Size box. For example, enter 720 to create and store proxies 720 pixels wide. Proxy height is determined by the clip's aspect ratio, relative to the proxy width that you set.

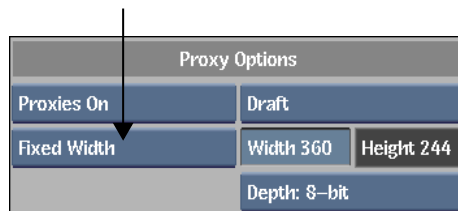

TIP When the proxy and full resolution clip have the same bit depth, proxies are not stored for clips that are the same width as the proxy width. For example, if you set proxy width to 720, your project will not store proxies for NTSC clips (720x486). If the bit depth of the full resolution clip is greater than that of the proxy, proxies are stored for clips with the same width as the proxy.

- Select Frame Percentage from the Proxy Size box and then enter a value in the Scale field. For example, enter 0.50 to create and store proxies that are 50% of the clip resolution.

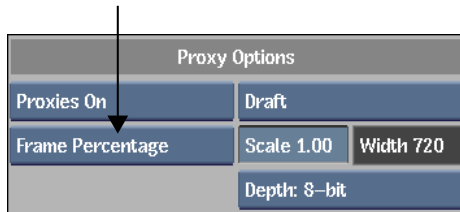

Proxies always have the same aspect ratio as the full-resolution clip. The width of proxies for clips with the default resolution corresponding to the scale value you set is displayed in the Width field.

- 3 If you selected Proxies Conditional, set your conditional criteria:

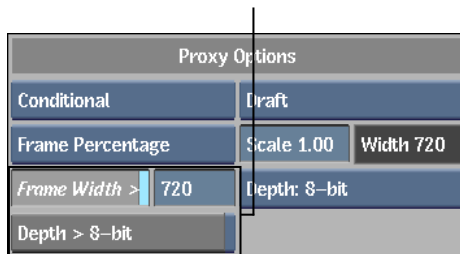

- To store proxies for all clips of a certain width and greater, enable Frame Width > and then enter a value in the adjacent field. For example, enter 1000 to store proxies for all clips wider than 1000 pixels.
- To store proxies only for 10-bit, 12-bit, or 12-bit unpacked clips, enable Depth > 8-bit.

NOTE These two settings are not mutually exclusive. For example, if you enter a value of 1000 in the Frame Width field and enable Depth > 8-bit, a 12-bit clip with a width of 720 will get proxies as long as the project proxy width is less than 720.

- 4 From the Proxy Quality box, set the quality of the proxy image for viewing purposes.



Proxy quality affects processing and proxy generation duration since lower qualities are faster to calculate. However, the quality does not affect the amount of framestore space required for proxies.

Select:	To specify:
Draft	The lowest possible quality. This is the quality used when proxies are generated automatically following video I/O.
Coarse	The next highest quality after Draft.
Medium	The next highest quality after Coarse.
Quality	The next highest quality after Medium.
Bicubic	The highest possible quality.

- 5 From the Proxy Bit Depth box, select the bit depth for proxies.



Select:	To set:
Depth: 8-bit	The proxy bit depth to 8 bits.
Depth: Full Res	The proxy bit depth to be the same bit depth as that of the clip.

Setting the Graphics Processing Bit Depth

Depending on your system, you can specify the bit depth for images that are processed using the frame buffer in the graphics card. The bit depth affects the quality of the resulting clip. Images can be processed with 8-bit or 16-bit FP precision.

As a rule, if you are working with mixed resolutions and some clips are higher than 8-bit, you should select 16-bit FP graphics display. Even if you work only with 8-bit images, you can get better processed results with 16-bit FP graphics processing when transparencies, blending, and gradients are part of your effect. 16-bit FP graphics processing produces better results but takes longer.

Projects from previous versions of the application with a graphics bit depth higher than 8-bit are mapped to 16-bit FP in the 2009 release.

Also, if your output is ultimately an 8-bit format, having the best possible quality immediately prior to output produces the best results.

To set the graphics processing bit depth:

- 1 Select an option from the Graphics Processing box.

720 x 486	NTSC
Width 720	Height 486
Set to 4:3	Ratio 1.333
8-bit	Field 1
8-bit Graphics	

Selecting the Project Configuration Template

Each project has an associated project configuration file. When you load a project, its project configuration file is parsed. Information in the project configuration file determines project environment settings such as graphics monitor refresh rate, default timecode for clips, and default framerate for clip playback.

A project's configuration file is created based on a project configuration file template. The template specifies project settings typically associated with the project's default resolution.

When you select a resolution preset (see [Setting the Default Resolution](#) on page 531), a project configuration template appears in the Configuration Template box.

Create Project	Name		
	Description	Created: Wed Jun 20 13:58:02 2007	
	Setup Directory	[Untitled]	
	Setup Mode	Copy From	test
Reset	Cfg Template	ntsc.cfg	

a

(a) Configuration Template box

This template corresponds to the selected resolution preset. However, you can select another option from the Configuration Template box, which lists all templates supported by the current workstation. Custom template names end in *_custom.cfg*.

The project configuration file primarily defines the display environment, and in no way restricts you from working with clips of another resolution. Furthermore, you can modify a project at any time.

For more information on project configuration file templates, refer to the *Autodesk Visual Effects and Finishing Configuration File Reference Guide*.

Modifying a Project

You can modify any project that appears in the Project box on start-up or during a session as long as it is not currently in use.

If you want to modify proxy management options, you can only modify the currently loaded project and only in mid-session (from the Preferences menu). The currently loaded project is indicated in the Project box in the Preferences menu by a light blue LED to the left of its name.

To modify a project:

- 1 Do one of the following:
 - If you are modifying a project on start-up, select the project you want to edit from the Project box and then click Edit. If the project exists on a remote framestore, select the framestore and volume (if applicable) and click Open. Then select the project and click Edit.



- If you are modifying a project in the middle of a session (you are already on the Flame desktop, click Preferences, select the project you want to modify from the Project box in the Project Management section of the Preferences menu, and then click Edit.



NOTE If you have a long list of projects to sort through, you can use the Sort Order box and arrow to sort the projects by frame resolution, name, or creation date, in descending or ascending order.

The Project menu appears.

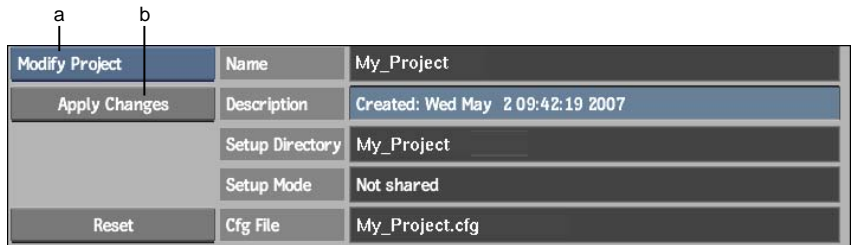

Modify Project	Name	My_Project
Apply Changes	Description	Created: Wed May 2 09:42:19 2007
	Setup Directory	My_Project
	Setup Mode	Not shared
Reset	Cfg File	My_Project.cfg

(a) Project Edit box (b) Apply Changes button

- 2 Modify the project parameters as required. See:
 - [Setting the Default Resolution](#) on page 531
 - [Setting Proxy Management Options](#) on page 532
 - [Setting the Graphics Processing Bit Depth](#) on page 536
- 3 When you are satisfied with your modifications, make sure Modify Project is selected from the Project Edit box, click Apply Changes, and confirm. You are returned to the Project Management or Preferences menu.

TIP To restore the project's current settings at any time, click Reset.

Deleting a Project

Projects are associated with setups and clips. You can delete a project, its setups, or its clips. When you delete a project, all its clips are deleted. Its setups are also deleted as long as they are not shared with a project already in use.

NOTE You can delete the setups and clips of any project. However, you cannot delete a project that is currently loaded or in use by a remote framestore.

To delete a project, its setups, or its clips:

- 1 If you are deleting a project, make sure it is not the currently loaded project—load a different project if needed. The currently loaded project is indicated in the Project box by a light blue LED to the left of its name.
- 2 Display the Project menu by doing one of the following:
 - On start-up, select the project you want to delete from the Project box and then click Edit. If the project exists on a remote framestore, select the framestore and volume (if applicable) and click Open. Then select the project and click Edit.



- If you are modifying a project in the middle of a session (you are already on the Flame desktop), click Preferences, select the project you want to delete from the Project box in the Project Management section of the Preferences menu, and then click Edit.



- 3 In the Project menu that appears, select an option from the Project Edit box.

Modify Project	Name	This_Project
Apply Changes	Description	Created: Wed Jun 27 16:39:10 2007
	Setup Directory	This_Project
	Setup Mode	Not shared
Reset	Cfg File	This_Project.cfg

Select:

To delete:

Delete Setups All the setups, but keep the project and the clips.

Delete Clips All the clips, but keep the project and the setups.

Delete Project A project entirely.

WARNING When you delete a project's setups, the setups for all projects that share the same setups are also deleted as long as the projects are not in use. The Setup Mode box indicates whether or not setups are shared.

4 Complete the deletion:

- If you selected Delete Setups, click Delete Setups and confirm.
- If you selected Delete Clips, click Delete Clips and confirm.
- If you selected Delete Project, click Delete Project, confirm, and then confirm a second time.

You are returned to the Preferences menu.

TIP To exit the Project menu without deleting the project, click Exit Project.

Managing Proxies

Proxies are low-resolution copies of high-resolution images, one for each frame. Proxies are used to provide:

- Real-time playback of processed results (where the full-resolution clips are too big to play back in real time).
- Low-resolution stand-in clips in a compositing environment (Action or Batch) so you can create composites more quickly.

- A fast render preview in some modules, such as Action, and for soft effects and transitions in soft-edited clips on the Desktop.
- A fast work environment for a project when using proxies without the original media. You can capture proxies only or remove media from clip metadata while retaining proxies. The original media is recaptured and relinked to the clip metadata prior to output.

Proxies can be regenerated at any time, and you can even extract proxies from a clip. Extracting proxies is a quick way to deliver a review version of a high-resolution clip.

Proxy Playback

A proxy is stored for every processed clip, provided proxy management options are enabled and the clip meets any conditional proxy generation criteria (see [Setting Proxy Management Options](#) on page 532). Because high-resolution images cannot always be played back in real-time, you can set the Player to play back proxies. Image quality is reduced, but real-time playback ensures you get a more accurate playback context.

To enable proxy playback:

- 1 Load a high-resolution clip with proxies in the Player.

TIP Alt-click clips on the Desktop or in the clip library to verify whether or not a clip has proxies, and what the proxy resolution is.

- 2 From the Play Resolution box, select Proxies.



NOTE If the Proxies option does not appear in the Play Resolution box, the current clip does not have proxies associated with it..

Proxy Processing

If you are creating a composite of high-resolution images in Action or Batch, you can enable proxy processing options. In this case, you work with proxies to create your composite, thereby demanding less of Flame in terms of memory management and intermediate processing (such as previewing results in-progress). You can also process proxies for soft effects on the timeline.

When you are satisfied with your result, switch to full-resolution processing, fine-tune settings to account for changes introduced by the higher resolution clips, and then process the result. This workflow can greatly accelerate your work.

- For information on proxy processing in Action, see the following sections in [Action: Basics](#) on page 2087:
 - [Resolution Settings](#) on page 2116
 - [Miscellaneous Settings](#) on page 2121
 - [Schematic Settings](#) on page 2125
- For information on proxy processing in Batch, see [Using Proxies in Batch](#) on page 1286.

Regenerating Proxies

If the current project is set to store proxies, you can regenerate proxies at any time. Regenerate proxies if you want to change the proxy quality.

Do not regenerate proxies if your project contains clips unlinked with the Unlink Hires option, and you are working on proxies only. After regeneration, these clips will be left with clip metadata that has neither the original media nor proxies linked to it. If this occurs, you will not be able to continue working on the clips without recapturing and relinking the media to them.

To regenerate proxies:

- 1 In the Main menu, click Format.
- 2 Click Regenerate Proxies.

LIBRARY	▶ Deinterlace	Remove Pulldown
EDITING	▶ Interlace	Add Pulldown
PROCESSING	▶ Field Merge	Burn In
EFFECTS	▶ Dominance	Change TC / KC / Rate
FORMAT	▶ Extract Proxies	Regenerate Proxies

3 From the Filter box, select an option.

Proxy Width 1024
8-bit
Draft
Clip

4 From the Apply To box, select an option.

Proxy Width 1024
8-bit
Draft
Clip

Select:	To regenerate:
Clip	Proxies for the selected clip.
Reel	Proxies for all clips on the reel to which the selected clip belongs.
Desktop	All clips on the desktop.

5 Select the clip and then confirm to regenerate its proxies.

Extracting Proxies

You can extract proxies from high-resolution clips to create a new clip. Extracting proxies can be a quick way to produce a low-resolution version of

a high-resolution clip for intermediate review. The advantage of extracting a proxy rather than, for example, resizing the high-resolution clip, is that the process is instantaneous and there are no increases to storage requirements because the media has already been generated.

To extract proxies:

- 1 In the Main menu, click Format.
- 2 Click Extract Proxies.

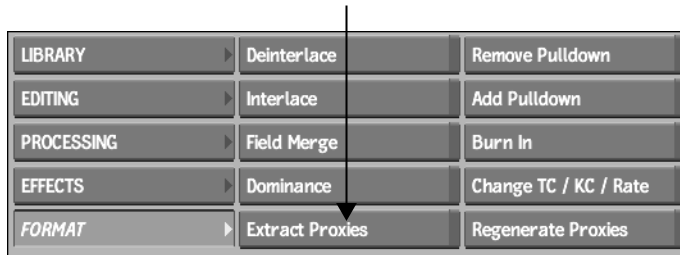

- 3 Select the clip on the desktop that has the proxies that you want to extract, and then select a destination reel.

Auto-Connecting Clip Libraries Belonging to Other Projects

Although projects are associated with their own clip libraries and clips, you can use Flame to share clip libraries and clips belonging to other projects on the local system, or over the Wire network. Shared libraries can be set up on a session-to-session basis, or you can auto-connect shared libraries so that they automatically appear in the clip library box of the current project on start-up. See [Selecting Clip Libraries in Local or Remote Projects](#) on page 597.

Creating and Loading a User and Sharing User Preferences

Create a user to manage your own preferences. Flame also provides tools to share preferences between users.

Users do not persist when upgrading from one version of Flame to another. You need to create new users for the new version. Also, users are not shared

between Autodesk Visual Effects and Finishing products. To see the list of users that are no longer compatible with the current version, enable Show All in the Project Management menu. All incompatible users are identified as such in the User box.

Creating a User

You can create a user on start-up from the Project Management menu or during a session from the Preferences menu. By default, a user's preferences directories are created in the directory `/usr/discreet/user/effects/<user name>`. However, you can override this default path and select a custom path. You can also copy preferences from an existing user to a new user.

To create and load a user:

- 1 Do one of the following:
 - If you are creating a user on start-up, select <new> from the User box in the Project Management menu.

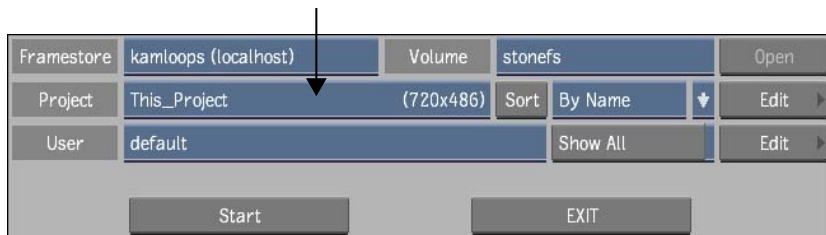

- If you are creating a user in the middle of a session, select <new> from the User box in the Preferences menu.



The Create User menu appears.

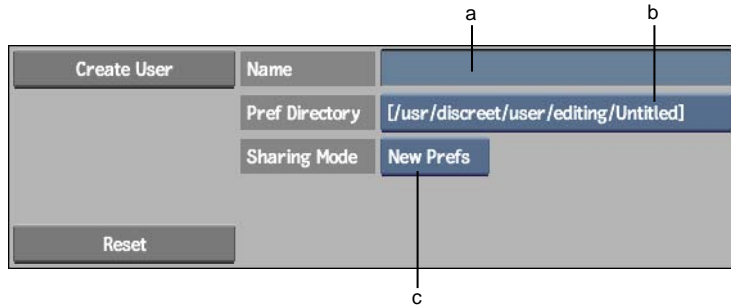

(a) Name field (b) Preferences Directory box (c) Sharing Mode box

- 2 In the Name field, type a name for the user.
- 3 The user's default home directory appears in the Preferences Directory box. To set a custom directory path for your preferences directories, select <new> from the Preferences Directory box and then use the file browser to set the user's home directory.
- 4 By default, the sharing mode for the new user is set to New Prefs. To copy the preferences of an existing user, select Copy From in the Sharing Mode box. Then select the user whose preferences you want to copy from the box that appears adjacent the Sharing Mode box.
- 5 To create the user according to the current settings, click Create User. The user is created, and you are returned to the Project Management or Preferences menu.

TIP To reset all user settings to their default values at any time, click Reset. To exit the Create User menu without creating a user, click Exit User.

- 6 To load the user into the current work session, click Load from the Preferences menu.

Saving and Loading Module Preferences

Desktop and module preferences are saved either when you exit the application or load another user. However, you may have other preferences that you want to set up for different kinds of work in the same module.

An easy way to keep several sets of preferences for a module is to save module preferences to your user's home directory. You can even copy these preference

resource files to a networked location or to a portable medium and load them on other systems. You can also load the module preferences of another user at any time. See [Saving, Loading, and Deleting Items](#) on page 802.

Modifying a User

You can modify the name of an existing user. You cannot change the preferences directory or sharing mode of a user.

To modify a user's name:

- 1 Do one of the following:
 - If you are modifying a user on start-up, select the user you want to edit from the User box and then click Edit.



- If you are modifying a user in the middle of a session, click Preferences in the Main menu, select the user you want to modify from the User box, and then click Edit.



The Modify User menu appears.

Modify User	Name	David
Modify User	Pref Directory	/usr/discreet/user/editing/David
	Sharing Mode	Not shared
Reset		

(a) User Edit box (b) Name field

- 2 To change the name of the user, enter a new name in the Name field.

- 3 **TIP** To restore the user's current settings at any time, click Reset. To exit the User menu without modifying the user, click Exit User.

- 4 Once you are satisfied with your modifications, make sure Modify User is selected from the User Edit box, click Modify User, and confirm.
You are returned to the Project Management or Preferences menu.

Deleting a User

You can delete a user when you no longer need the associated preferences. You can delete users from previous versions.

NOTE You cannot delete the currently loaded user. The currently loaded user is indicated in the User box in the Preferences menu by a light blue LED to the left of its name.

To delete a user:

- 1 Display the User menu by doing one of the following:
 - On start-up, select the user you want to delete from the User box and then click Edit.



- In the middle of a session, click Preferences in the Main menu, select the user you want to delete from the User box, and then click Edit.



NOTE To see the list of users that are no longer compatible with the current version, enable Show All. All incompatible users are identified as such in the User box.

- 2 Select Delete User from the User Edit box.



If you delete a user that has shared preferences, the preferences directory is not deleted from the filesystem. The preferences directory is deleted only if no other user shares the preferences.

TIP To exit the User menu without deleting the user, click Exit User.

- 3 Click Delete User and confirm.
You are returned to the Project Management or Preferences menu.

Loading Different Projects and Users during a Work Session

During a work session, you can load other projects and users.

Loading a Different Project

During a work session, you can load any another project. Doing so changes the display environment according to the configuration of the project you choose to load. If you are on a remote framestore, you cannot load a project that is already in use.

To load another project:

- 1 In the Main menu, click Preferences.

The Preferences menu appears.



(a) Project box (b) Load button

- 2 From the Project box, select the project you want to load.

TIP The currently loaded project is indicated by a light blue LED to the left of its name.

- 3 Click Load.

The graphics monitor switches to the new display settings, and after a few moments, the new project is loaded.

Loading a Different User

During a work session, you can load any other user.

To load another user:

- 1 In the Main menu, click Preferences.
The Preferences menu appears.



(a) User box (b) Load button

- 2 From the User box, select the user you want to load.

TIP The currently loaded user is indicated by a light blue LED to the left of its name.

- 3 Click Load.

NOTE Any changes to preferences made in the current session are saved when you load another user.

About Multi-Format Projects

You can work with clips of any resolution in your project. You can process images of differing resolutions in Flame. The video I/O procedures that you use to input and output clips to and from Flame using a VTR, as well as capture and assemble EDLs, are not restricted to your project's default resolution. You can input and output clips of another video resolution to and from your project. See [Working with Multi-Format Input and Output](#) on page 164.

Working with Remote Framestores

You can use a remote (network-accessed) framestore to store clips with Flame. This allows you to use Flame without local storage.

This functionality is not intended to allow collaborative and concurrent access to a central project from several remote workstations. A project remains tied to the workstation it is created on, and is meant for single-user access.

The remote framestore used is specified at startup. See [Start-up Options](#) on page 920.

Topics in this chapter:

- [About Clip Libraries](#) on page 555
- [Creating Clip Libraries](#) on page 557
- [Opening Clip Libraries](#) on page 558
- [Using the Dual Library View](#) on page 559
- [Saving to Clip Libraries](#) on page 561
- [Viewing Entries in Clip Libraries](#) on page 564
- [Selecting Entries](#) on page 580
- [Searching for Clips](#) on page 582
- [Organizing Clips](#) on page 584
- [Loading Clips to the Desktop](#) on page 591
- [Copying Local and Remote Clip Libraries to Your Current Project](#) on page 593
- [Troubleshooting Lock Files](#) on page 600

About Clip Libraries

Use clip libraries to store and organize the clips in your project. You can save individual clips, all clips on a reel, or all clips on the desktop to a clip library. You can also load any clip, reel, or desktop for use in the current work session. You can delete saved items you no longer need from a clip library.

For each project, a clip library named *Default* is created. You can use the Default clip library or create your own. You can create one or multiple clip libraries per project. For example, create one clip library to save the clips used for a commercial spot and another to save all the clips used to produce an effect such as a warp. Each clip library you create is stored in the current project. Clip libraries support clips of any resolution.

Clip libraries can be displayed in two modes, SingleView and Dual View. Single view is the default view and displays the contents of one clip library. Dual View displays the contents of two clip libraries, each in its own panel. Dual View allows you to use drag and drop functionality to copy and move clips, reels, and projects.

You can access clip libraries in other projects (either local or remote). To access projects on remote machines, you must have Wire. See [Copying Local and Remote Clip Libraries to Your Current Project](#) on page 593. You can also access clip libraries on a standard filesystem. See [Importing and Soft-Importing Image Files](#) on page 210.

Clip metadata is stored in clip libraries on your computer's hard disk in `/usr/discreet/clip/<volume name>/<project name>`. The actual frames are stored either on the framestore or on the standard filesystem. Media that is soft-imported is not written to the framestore.

Clip metadata comprises various characteristics on the clip, including:

- A clip ID that is used by setups to retrieve associated clips and to optimize archiving processes
- Frame IDs that refer to the frames on the framestore or standard filesystem
- Timecode, keycode, and video or audio track numbers
- Audio tracks, if they have been linked to the clip
- Other metadata such as aspect ratio and scan mode

Each frame consists of:

- The image, which is composed of pixels
- A frame ID

You can load the same clip from a clip library multiple times onto the Desktop. This repetition of the original frames does not take up space on the framestore because what you actually load are references to the original frames. However, if you create an effect such as colour correction and then process new frames,

the frames will be stored on the framestore. Information about current framestore usage is provided in the message bar. You can also load a clip from the standard filesystem. This clip does not occupy space on your framestore until you write the clip to the filesystem.

Creating Clip Libraries

You can organize projects by creating clip libraries and using them to store related desktops, reels, and clips together. It is recommended that you use several small clip libraries instead of one large one. This helps to keep your projects organized, allows for more efficient transfers of data, and streamlines clip library performance.

NOTE For optimum performance, ensure that the `MaxLibrarySize` token in the `init.cfg` configuration file is set properly. Refer to the *Autodesk Visual Effects and Finishing Configuration File Reference Guide*.

Use the Clip Library box on the Desktop to create clip libraries.

To create a clip library:

- 1 Select <new> from the Clip Library box.

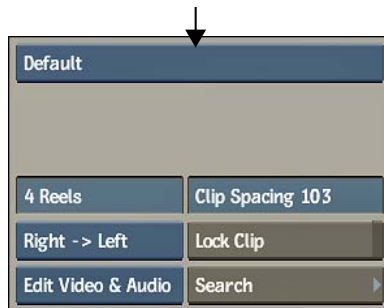

The keyboard appears.

- 2 Enter a name for the new clip library. Use only alphanumeric characters, single spaces, and underscores. Click Enter on the on-screen keyboard (or press **Enter**).

The clip library is created and appears in the Clip Library box.

Opening Clip Libraries

The Clip Library box contains a list of all available clip libraries. The clip library displayed on the box label is the currently selected clip library. You can open the current clip library or select and open another clip library. You can also view the contents of two separate clip libraries at the same time. See [Using the Dual Library View](#) on page 559.

Use the Clip Library box to open a clip library.

To open a clip library:

- 1 From the Clip Library box, select the clip library you want to open.

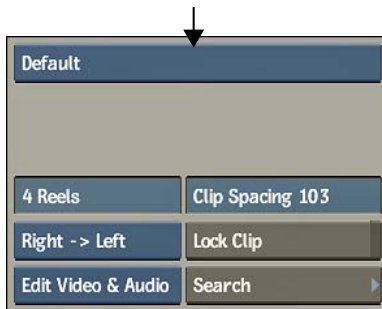

NOTE If the list of clip libraries is too long to display all libraries, move the cursor onto the scroll arrow on the last visible clip library in the list. The list will scroll down.

- 2 Do one of the following:
 - In the Main menu, click Library, click Load, and then select a destination.
 - Click Load on the reel to which you want to load clips.

The clip library opens.

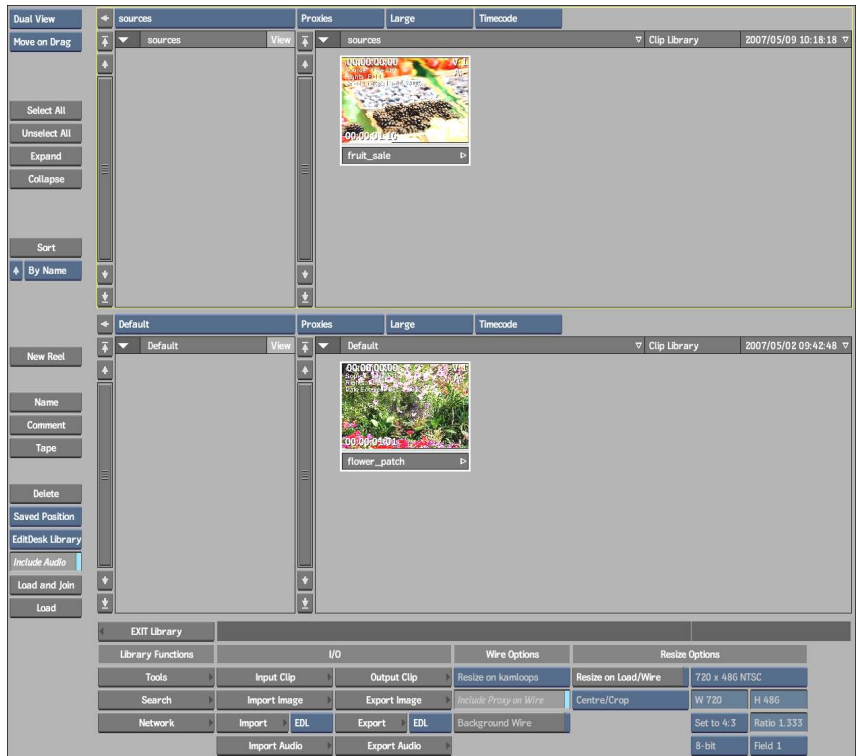

TIP You can also create new clip libraries and switch clip libraries using the Clip Library box in the current clip library.

To exit a clip library without loading any clips, click the EXIT Load button. See [Loading Clips to the Desktop](#) on page 591.

Using the Dual Library View

The Dual Library View allows you to open, view, and work with two separate clip libraries at the same time. With Dual View you can:

- Copy and move clips between libraries.
- Copy and move clips between local or remote projects while maintaining the project's structure.
- Copy clip libraries between workstations.

To display the Dual Library View:

- 1 Open a clip library.
- 2 Click the Library View Mode button located at the top-left portion of the screen.

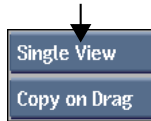

The Dual Library View appears.

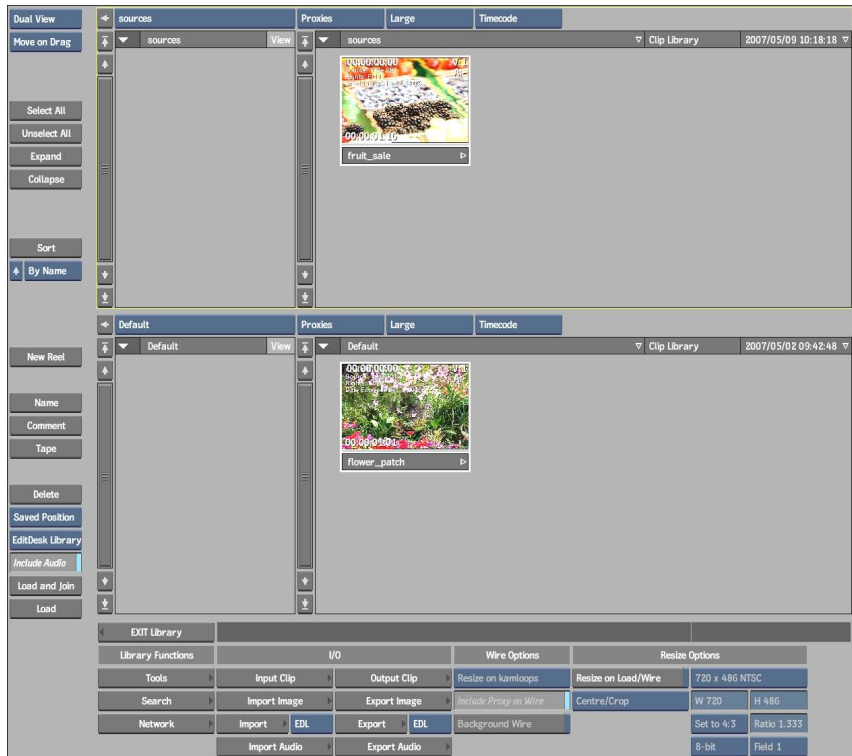

When working in Dual Library View, you make a library active by clicking it. The active library is surrounded by a yellow box.

NOTE When switching between views, the currently selected library remains active. For example, the active library in Dual View will appear when you switch to Single View.

Saving to Clip Libraries

Use the Save command in the Library menu to save a clip, reel, or desktop to the current clip library.

NOTE You cannot save clips, reels, or desktops to read-only clip libraries.

To save a clip, reel, or desktop to a clip library:

- 1 In the Main menu, click Library.
- 2 From the Clip Library box on the desktop, select the clip library where you want to save the item.
- 3 Click Save in the Library menu.
The cursor changes to a red selection arrow and the Media Type box appears.
- 4 Select an option from the Media Type box.

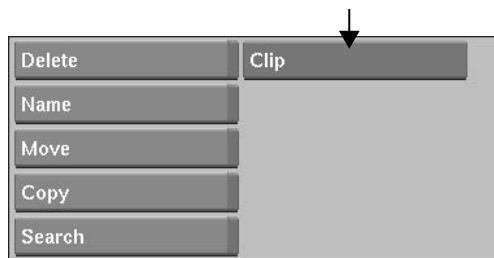

Select:	To save:
Clip	A clip or soft edit to the current clip library.
Reel	A reel to the current clip library.
Desktop	The desktop to the current clip library.

When you select Clip or Reel, the selection cursor remains. When you select Desktop, a Confirm button appears.

- 5 Do one of the following:
 - To save a clip, click in its upper-left corner.

If the clip has a resolution that does not match the project resolution, the timecodes or frame numbers that appear on the clip on the desktop and in the clip library are light blue.

- To save a reel, select any clip on the reel.
- To save a desktop, click Confirm. To cancel, click in a grey area of the menu.

The on-screen keyboard appears.

- 6 Type a name for the clip, reel, or desktop and press **Enter**.

If the clip, reel, or desktop already has a name, the name appears in the Name Entry field. You can change the name, or press **Enter** to accept the existing one.

- 7 If there are already one or more entries in the clip library with the same name and of the same type that you are saving, a warning message states that an entry with the same name already exists and the Add, Replace, and Rename buttons appear.



Click: **To:**

Add Add the clip, reel, or desktop to the clip library. You will have two entries with the same name in the clip library.

Replace Replace the existing entry or entries with the clip, reel, or desktop you are saving.

Rename Enter a different name for the clip, reel, or desktop you are saving.

To cancel the operation, click elsewhere in the menu.

Shortcut for Saving Reels and Desktops

You can use the Save buttons to save a reel or desktop to a clip library. Use the Save Reel button to save all the clips in a particular reel to the current clip library. Use the Save Desktop button to save all the clips on the desktop.

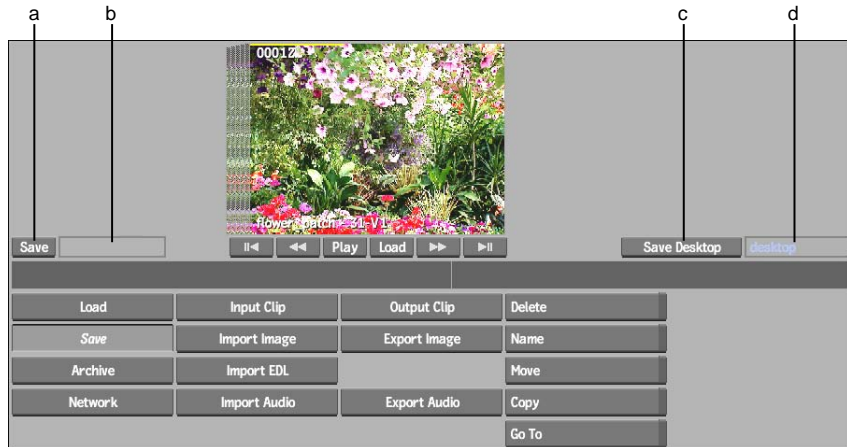

(a) Save Reel button (b) Reel Name field (c) Save Desktop button (d) Desktop Name field

To save a reel or desktop:

- 1 From the Clip Library box on the desktop, select the clip library where you want to save the reel or desktop.
- 2 Click the Save Reel or Save Desktop button.
The on-screen keyboard appears. If the reel or desktop already has a name, it is displayed in the Name Entry field; otherwise, the field is blank.
- 3 Type a new name or accept the existing one and click Enter.
The reel or desktop is saved to the current clip library. If a clip on the reel or desktop has a resolution that does not match the project resolution, the timecodes or frame numbers that appear on the clip on the desktop and in the clip library are light blue.

Viewing Entries in Clip Libraries

The contents of clip libraries can be displayed in two panels: the Reels panel on the left, which displays the reels in the library, and the Clips panel on the right, which displays the clips associated with the selected reel.

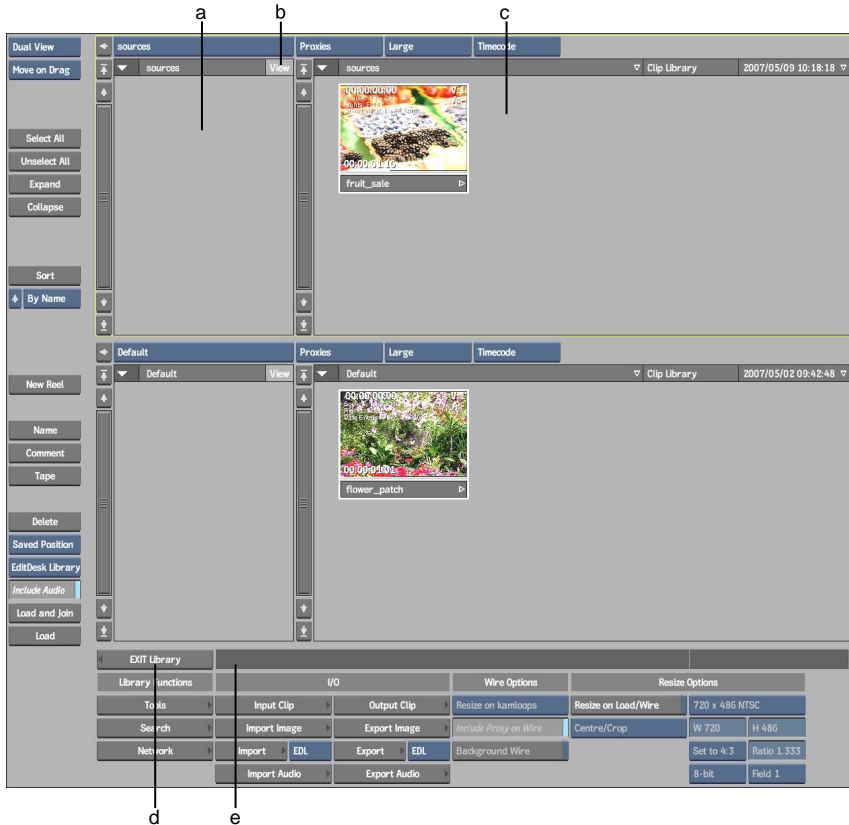

(a) Reels panel (b) View Reels control (c) Clips panel (d) Exit Library button (e) Message bar

You can display proxies (pictures) of the clips, or you can choose to display just the titles of the clips. You can scroll entries in a clip library and expand, collapse, and sort entries. You can also rename the tape, and add comments.

You can view clip information by pressing **Alt** and placing the mouse cursor over a clip entry. The clip name, resolution, aspect ratio, and proxy status appear in the message bar.

Clips that have a resolution that differs from the project default resolution are identified by a blue timecode or frame number display. When a clip contains segments of different resolutions, a “MIXRES” label appears on the clip proxy.

Expanding and Collapsing the Reels Panel

The Reels panel of the clip library window displays the reels associated with a library. You may find it useful to display the Reels panel if you have many reels in your library. You use the Expand and Collapse arrows to expand and collapse the Reels panel.

To expand and collapse the Reels panel:

- 1 With the Reels panel collapsed, click the Expand arrow.



The Reels panel appears displaying all of the reels in the library. When you double-click on a reel, the clips associated with it appear in the Clips panel to the right of the reel.

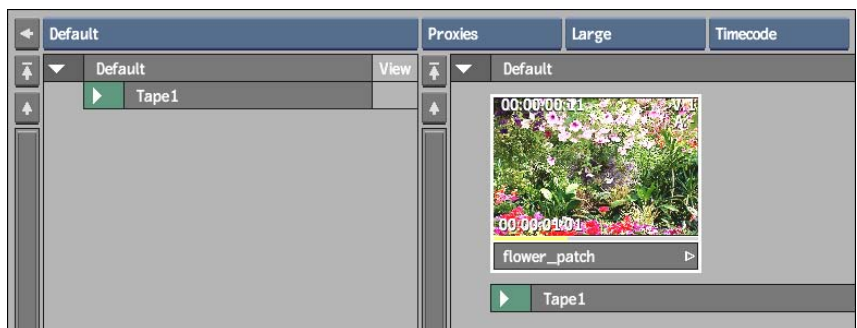

- 2 With the reels section expanded, click the Collapse arrow.
The Reels panel collapses and all of the reels and clips in the library are displayed.

Viewing the Contents of a Specific Reel

You can view the contents of specific reels in the library.

To view the contents of a specific reel:

- 1 Display the Reels panel.
- 2 Click the View Reels control.

The contents of the reel you selected are displayed.

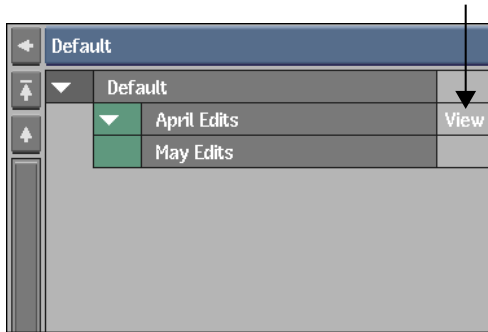

NOTE To display the contents of numerous reels, use **SHIFT**-click to select them.



Scrolling a Clip Library

Scroll the contents of the current clip library using the scroll bar. You can also press the **up arrow** or **down arrow** key to scroll. The scroll bar buttons are described as follows.

Click: **To:**



Scroll up a page.

Click:	To:
	Scroll up by one entry.
	Scroll down by one entry.
	Scroll down a page.

Changing the View Mode

You can view clip libraries in either Single, or Dual View mode. The libraries' contents can be viewed in Proxies, Titles, or List View mode. Switch modes by selecting a view in the View Mode box or by pressing **P** (Proxies), **T** (Titles), or **Ctrl-L** (List View).

NOTE To switch to List View mode, you must use the View Mode box.

Viewing Clips in Titles Mode

Use Titles mode to view all the entries in a clip library by name.

To view titles:

- 1 Do one of the following:
 - From the View Mode box, select Titles.
 - Press **T**.

In Titles mode, entries are presented as a series of horizontal bars.

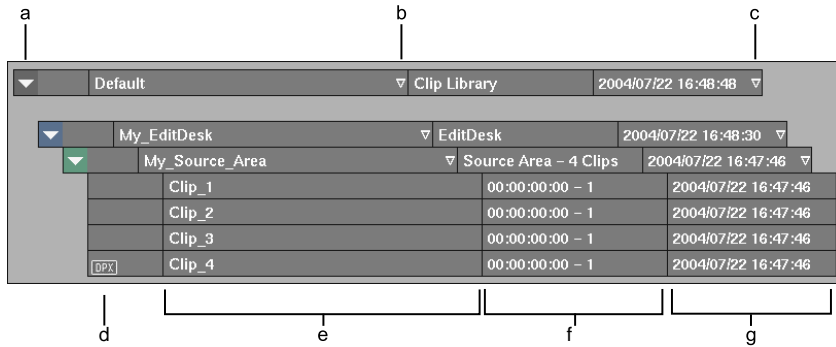

(a) Collapse arrow (b) Name Sort arrow (c) Date Sort arrow (d) Soft-import indicator (e) Name (f) Description (g) Creation Date field

The bars consist of the following arrow buttons and fields.

Expand or Collapse arrow Click the Expand or Collapse arrow to expand or collapse entries. See [Expanding and Collapsing Entries in Titles and Proxies Mode](#) on page 573.

The colour of the box surrounding the arrow indicates the type of entry. The colour of the arrow indicates whether contained entries are selected. See [Entry Colours](#) on page 575.

Name field Contains the entry's name. If a name is not specified when an entry is saved, this field is labelled *<untitled>*. See [Renaming Entries](#) on page 588.

Name Sort arrow Click to alphabetically sort entries by name. See [Sorting Entries in Titles and Proxies Mode](#) on page 572.

Description field Contains a brief description of the entry. For example, a reel is described as "Reel - *n* Clips" where *n* is the number of clips in the reel.

Creation Date field Provides the date and time the entry was created.

Date Sort arrow Click to sort entries by creation date. See [Sorting Entries in Titles and Proxies Mode](#) on page 572.

Viewing Proxies

Use Proxies mode to view the clips and soft edits in a clip library as proxy images. Clips only appear in Proxies mode if the entry that contains them is expanded. All other entries are listed as titles.

To view proxies:

- 1 Do one of the following:
 - From the View Mode box, select Proxies.
 - Press **P**.

The Proxy Size box and Information box appear.

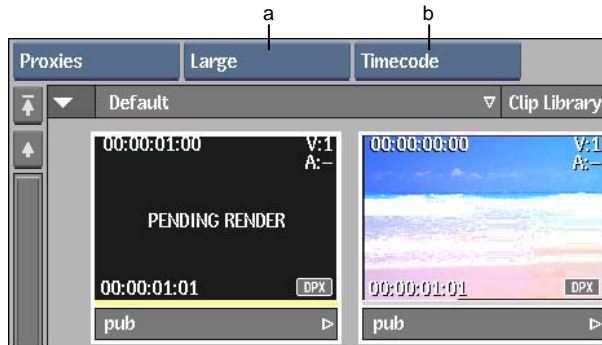

(a) Proxy Size box (b) Information box

- 2 From the Proxy Size box, set the size of the proxies to large, medium, or small.
- 3 From the Information box, select one of the following options.

Select:	To:
No Display	Disable the display of information on clips.
TC + Res	Display current timecode, duration, clip dimensions, bit depth, and aspect ratio.
Frame + Res	Display current frame number, duration, clip dimensions, bit depth, and aspect ratio.
Timecode	Display current timecode and duration.
Frame	Display current frame number and duration.

NOTE Keycode is displayed for all options except No Display. See [Displaying Timecode and Keycode](#) on page 405.

The selected information is displayed on the proxy.

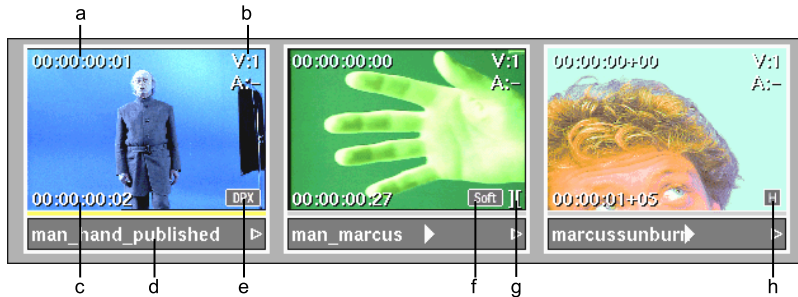

(a) Current timecode; keycode is also displayed if present (b) Number of video and audio tracks (c) Clip duration (d) Name bar (e) Soft-import indicator (for a clip that is not a hybrid) (f) Soft-import indicator (for a hybrid clip) (g) Soft Edits label (h) Clip History indicator

Left image courtesy of Behavior Communications Inc.

Clip History indicator Clips that have clip history have an indicator. See [About Clip History](#) on page 807.

Soft-import indicator Clips that are soft-imported have an indicator, the type of indicator depends on whether the clip is a hybrid clip or a completely soft-imported clip. A hybrid clip has some frames that are soft-imported and some that are not. See [Importing and Soft-Importing Image Files](#) on page 210.

NOTE If you do not have read- and write-access to the clip, the resulting soft-imported clip will be black with a grey bar.

Proxies for Soft Edits Proxies for clips with soft edits (such as uncommitted cuts, dissolves, or splices) have a “]” label. If the clip has source clips, the proxy also has an Expand/Collapse arrow. Click the arrow to display or hide the source clips. The source clips are slightly smaller to distinguish them at a glance from other types of clips.

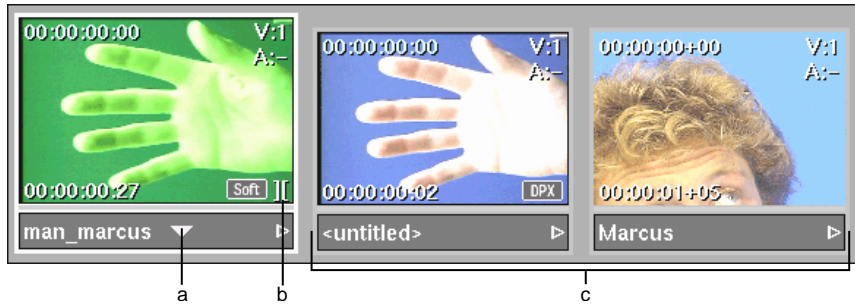

(a) Collapse arrow (b) Indicates a soft edit (c) Source clips

Proxies for source clips are identified by a dark grey border (proxies for regular clips have a light grey border).

NOTE If a portion of a soft clip resides in another project, a black proxy appears with the text “Not Transferred”. You must load the clip to the local project to view it in the library.

Jogging a Proxy You can view the contents of the clip by clicking the proxy in the jogging area and dragging left or right. A yellow indicator under the image shows the approximate position of the frame being shown.



(a) Image area (b) Jogging area

Viewing Clips in List View Mode

Use List View mode to view the clips and soft edits in a clip library in a list.

You can select, load, and rename entries from List View. However, you cannot perform drag and drop operations such as moving or copying entries.

To view List View Mode:

- 1 In the View Mode box, select List View.
See [Listing Clip Information](#) on page 575.

Sorting Entries in Titles and Proxies Mode

You can sort entries in clip libraries in Titles and Proxies mode using the Sort button or the Name and Date Sort arrows. Sorted entries of the same type are grouped together. For example, clips are grouped together and desktops are grouped together. You can sort all entries or top-level entries only. See [Sorting Clips in List View](#) on page 577.

To sort entries using the Sort button:

- 1 From the Sort box, specify whether you want to sort the entries by name or by date.

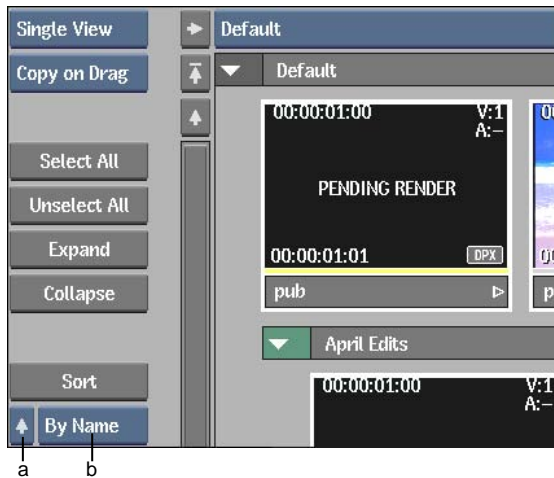

(a) Sort arrow (b) Sort box

Select:	To:
By Name	List entries of the same type in alphabetical order. Entries that begin with upper-case letters are grouped alphabetically before entries with lower-case letters.
By Date	List entries of the same type according to the date they were created. The most recent entry appears first.

- 2 Click the Sort arrow to determine whether the sort will be ascending or descending.
- 3 Click Sort.

All top-level desktops, reels, and clips are sorted.

- 4 To sort all entries, hold **Ctrl** and click Sort.

To sort using the Name Sort and Date Sort arrows:

- 1 Do one of the following:
 - To sort top-level entries alphabetically by name, click the Name Sort arrow.
 - To sort top-level entries by creation date, click the Date Sort arrow.
 - To sort all entries, **Ctrl**-click the Name Sort or Date Sort arrow.



(a) Name Sort arrow (b) Date Sort arrow

Expanding and Collapsing Entries in Titles and Proxies Mode

You can expand and collapse clip libraries, desktops, reels, and soft edits in the clip library. Clip libraries can contain desktops, reels, and clips. Desktops contain reels, and reels contain clips and soft edits. Clips and soft edits can be saved directly in the clip library or under a desktop or reel. You can also expand soft edits to view the source clips that were used during the creation of the soft edit.

When you view clip libraries in Titles or Proxies mode, the hierarchical structure is represented using indentation and Expand/Collapse arrows.

For example, if you save a reel, its clips are shown within a reel entry. The following figures show the result of saving a reel to a clip library.

The reel (named "Talent") with three clips



The “Talent” reel saved in a clip library

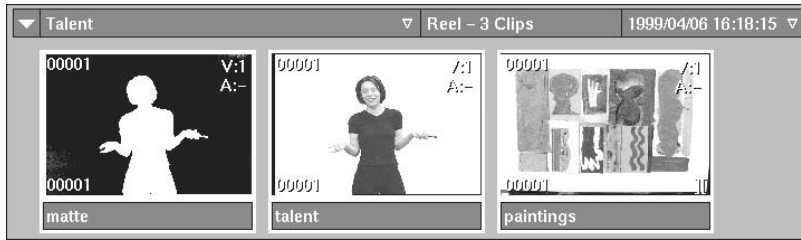

Use the Expand and Collapse buttons or the Expand and Collapse arrows to expand and collapse entries in the clip library. You can also use the hot keys **E** (expand) and **C** (collapse) for selected entries.

Click the Expand button to expand all selected parent entries except for soft edit entries. Soft edits are expanded separately using an Expand arrow that appears on the soft edit entry itself. Click the Collapse button to collapse all selected parent entries, including soft edits.

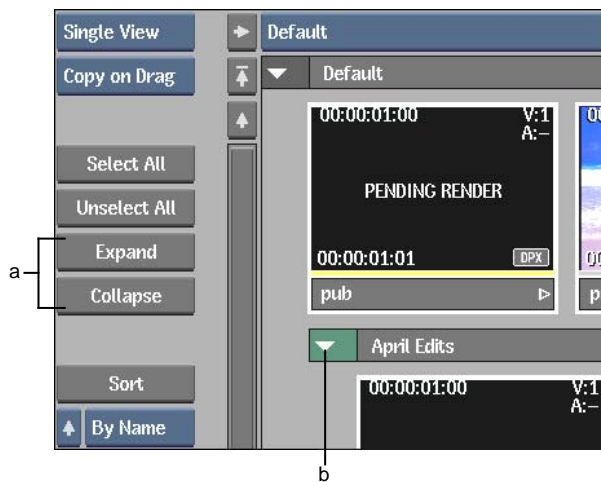

(a) Expand & Collapse buttons (b) Collapse arrow

Click the Expand and Collapse arrows to the left of a parent entry to expand or collapse it. When an entry is collapsed, the Expand arrow points to the right; when it is expanded, the Collapse arrow points down.

To expand or collapse all contained entries, **Ctrl**-click the arrow.

Entry Colours

Each type of entry uses a different colour in the box at the left of the entry. This box also contains the Expand or Collapse arrow.

This colour:	Represents:
<input type="checkbox"/> Dark Grey	Clip libraries.
<input type="checkbox"/> Blue	Desktop.
<input checked="" type="checkbox"/> Green	Reels and Source Areas (from Finishing products).
<input checked="" type="checkbox"/> Red	Record Areas (from Finishing products).
<input type="checkbox"/> Medium Grey	Clips and soft edits.
<input type="checkbox"/> Dark Grey	Clips from Finishing products.

Listing Clip Information

List View mode displays entries in the clip library as a list of clips. The list gives information about each clip, such as start and end timecode and keycode, clip duration, archive flag, and tape name.

Clip Information in List View

The following information is provided in List View.

Column:	Displays:
Sel	The order in which clips were selected.
Soft-import	Soft-import indicator if the media was soft-imported.
H	History indicator for clips containing history.
Location	Path of the parent entries in which the clip is located.
Clip Name	Name of the clip.
TC In	Start record timecode of the clip. If Frame is selected in the Information box, the equivalent frame number is displayed.

Column:	Displays:
TC Out	End record timecode of the clip. If Frame is selected in the Information box, the equivalent frame number is displayed.
Duration	Duration of the clip in timecode or frames.
Frames	Number of frames referenced by a clip.
KC In	Start keycode for the clip.
KC Out	End keycode for the clip.
Tape	Name of the associated tape. <N/A> indicates that the tape cannot be renamed. See Renaming a Clip's Tape in List View on page 578 and Editing an EDL on page 361.
V	Number of video tracks.
A	Number of audio tracks.
Width	Pixel width.
Height	Pixel height.
Bts	Bit depth.
SM (Scan Mode)	Whether the clip is field 1 or 2 dominant or is progressive.
P (Proxies)	Whether a proxy exists for the clip.
U (Unlinked)	Whether the media associated with the clip — video (V), audio (A), video and audio (V/A), or high-resolution media (HR) — has been unlinked.
E	Number of editing elements of the clip.
Created	Creation date and time of the clip.
Archived	Date the last time the clip was saved to an archive tape.
Comment	Comment for the selected clip.

Information Box

When you select List View, the Information box appears. Use this box to display the clip length in frames or timecode. To display frames, select either Frame, Frame + Res, or No Display. To display timecode, select Timecode or Timecode + Res.

NOTE Keycode is displayed for all options except No Display. See [Displaying Timecode and Keycode](#) on page 405.



(a) Information box

Sorting Clips in List View

In List View, you can sort on any field. Simply click the label of any field to sort by that field. The sort field is highlighted and contains a sort arrow at the right end of the label.



(a) Clip field (b) Sort arrow

The sort can be either in ascending or descending order. The arrow points down for an ascending alphanumeric sort and up for a descending sort. To toggle between ascending and descending sort, click the field label a second time.

Secondary Sorts

When you perform a sort on any field other than the Clip field, you automatically get a secondary sort on the Clip field. This means that you can sort by one field—the primary sort—and get a sort of the clip names within the other field—the secondary sort. For example, if you sort by the Location

field, you get a secondary sort by the clip name. Clips would then be sorted within their parent entries. Any field can act as a primary sort field, but only the Clip field can be the secondary sort field.

NOTE The default sort when you display List View is a primary sort on Location and a secondary sort on Clip.

To perform a secondary sort:

- 1 Click the Clip field for an ascending sort. Click it a second time for a descending sort.
 - 2 Click the field within which you want clip names to be sorted.
- A sort arrow appears on both the fields. The last field you clicked is highlighted, indicating this is the primary sort field.

Default						List View
Sel	H	Location	Clip Name	TC In	TC Out	Duration
		May Edits				
		April Edits				
2	DPX		Girl_published	00:00:00:00	00:00:01:00	31
1	DPX		Girl_published	00:00:00:00	00:00:01:00	31
3	DPX	May Edits	Girl_published	00:00:00:00	00:00:01:00	31
4	DPX		Girl_published	00:00:00:00	00:00:01:00	31
7		April Edits	output 11	00:00:00+00	00:00:02+13	62
6			Audio Track	00:00:00:00	00:00:29:29	900
5	AIF		Audio_Track	00:00:00:00	00:00:29:29	900

(a) Primary sort on Clip Name field (b) Secondary sort on Created field

List View is useful if you have clips with long clip names because you can resize any column to display more or less information. Place the cursor between any two columns in the column name area to display the column resize cursor. Drag the cursor to resize the column.

Renaming a Clip's Tape in List View

You can name or rename the tape of a captured clip or a source clip (such as a clip rendered in Flame) in List View. This is useful when a manually captured clip has been given the wrong tape name.

You cannot rename the tape for a clip in the clip library if <n/a> appears in the Tape column. The structure of the clip must resemble that of a captured

clip so that it can be associated with the EDL. Use the following guidelines to determine whether you can assign the tape name to a particular clip.

Video clip with no audio The clip can be a captured clip or a pure source clip (a clip rendered in Flame). Virtual source clips (for example, an uncommitted colour clip created with the Colour Source tool or a multitrack containing a virtual source) cannot be assigned a tape name.

Video clip with audio The start and end timecode of the audio and video must be the same. The video tracks must have the same source timecode and the same tape name. Also, if the video *or* audio has been rendered/mixed down, the clip cannot be assigned a tape name. However, if *both* video and audio have been rendered/mixed down, the clip can be assigned a tape name.

To name or rename the tape for one or more clips:

- 1 In the clip library, select List View from the View Mode box.



- 2 Select the clip(s). See [Selecting Entries](#) on page 580.
- 3 Click the Tape button and then click Confirm.
The on-screen keyboard appears; the Keyboard field contains the existing tape name.
- 4 Enter a name in the Keyboard field and press **Enter**.

NOTE The name can be up to 52 characters.

The name is applied to all selected clips. If there are clips in the selection that do not conform to the requirements for renaming the tape, they are not renamed. A message informs you of how many clips were renamed.

NOTE You can also rename the tape from Proxies or Titles view, but since there is no Tape field in these views, you cannot see the result.

Adding a Comment to a Clip

You can add a comment to a clip, for example, to remind you that the clip is part of a particular project.

To add a comment to a clip:

- 1 In the clip library, select List View from the View Mode box.
- 2 Click Comment to the left of the list.
The on-screen keyboard appears.
- 3 Type a comment and then press **Enter**.
The comment appears in the Comment column for the selected clip.

Selecting Entries

There are several methods for selecting and deselecting entries.

Select a single entry Click anywhere on the entry except on the Expand/Collapse arrow and Sort buttons. If the entry contains other entries, they are all selected.

In Titles and List View mode, a selected entry is light grey. On proxies, the name bar is yellow.

When an entry contains some selected entries, but not all of them, its Expand or Collapse arrow is yellow. When all of an entry's contained entries are selected, its Expand or Collapse arrow is green.

Select all entries contained in an entry Click the top-level entry.

Select a top-level entry only **Alt**-click the top-level entry. When you **Alt**-click the entry, its contained entries are not selected.

Selecting an entry without its contained entries is useful when you want to transfer entries between libraries using Wire. The library structure can be preserved without transferring clips.

Deselect one or more entries **Ctrl**-click a selected entry.

Add more entries to a selection **Ctrl**-click the entries you want to add.

NOTE If you **Ctrl**-click a collapsed entry, all contained entries are selected. To select certain entries under the parent entry, expand the parent entry and then **Ctrl**-click the entries.

Select a range of entries In Titles and Proxies modes, click the first entry in the range, then press **Shift** and click the last entry in the range.

In List View, you can also drag the cursor over the range of entries or **Shift**-click the first and last entry in the range.

Add a range of entries **Ctrl**-click the first entry in the range you want to add to your current selection. **Ctrl+Shift**-click the last entry in the range you want to add.

In List View, **Ctrl**-drag to select more entries.

Select all entries in the clip library Click the Select All button in the Library Management menu. Alternatively, click the clip library entry.

Deselect all entries Click the Unselect All button in the Library Management menu. Alternatively, click anywhere within the solid grey area of the clip library.

Selection Order

When you select several desktops, reels, and clips at once, the order in which they are selected is indicated by a number in the entry. The display of the selection order is useful when selecting multiple clips to perform a particular task. You can use the selection order numbers when changing the timecode of multiple clips with the Tools menu.

In Proxies and Titles modes, the selection order number is preceded by the number sign (#). In Proxies mode, the selection order number appears in the upper-right corner of the proxy below the video and audio track numbers, and to the left of the Name Sort arrow for desktop and reel entries.

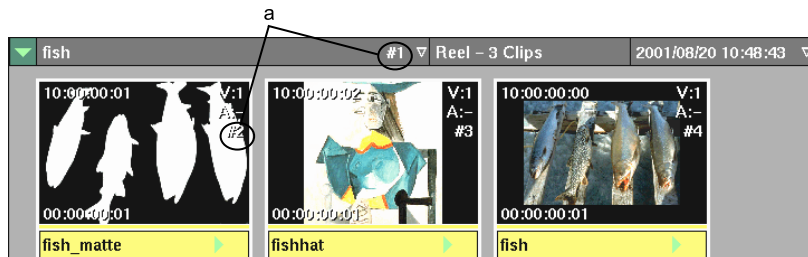

(a) Selection Order number in Proxies mode

In Titles mode, the selection order number appears to the left of the Name Sort arrow.

fish	#1	Reel - 3 Clips	2001/08/20 10:48:43
fish_matte	#2	10:00:00:01 - 1	2001/08/20 10:45:16
fishhat	#3	10:00:00:02 - 1	2001/08/20 10:45:16
fish	#4	10:00:00:00 - 1	2001/08/20 10:45:15

a

(a) Selection Order number in Titles mode

In List View mode, the selection order number appears in the Sel column.

Sel	Location	Clip Name
		COL_NOISE
1	DPX	kodak_girl
		The_Future_192_kbs.
2		YELLOW

(a) Selection Order number in List View mode

Searching for Clips

Use the Search menu to find a clip or a set of clips in the current clip library.

To search for a clip:

- 1 From the Clip Library menu, click Search.

The Search menu appears.

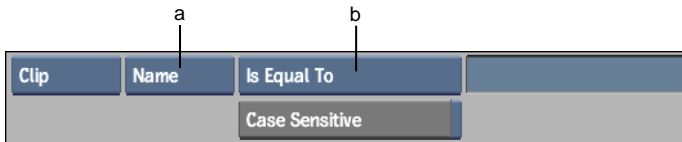

(a) Search option box (b) Argument option box

- 2 Select an option from the Search option box and use the Argument option box and field to supply the necessary arguments for that option.

Criteria Option	Specify	Possible Arguments
Name	A clip name	Is Equal To; Is Not Equal To; Contains; Does Not Contain; Is Less Than; Is Greater Than; Matches Pattern

Criteria Option	Specify	Possible Arguments
Soft-import	n/a	Contains; Does Not Contain
Clip History	n/a	Contains; Does Not Contain; Intermediates; Intermediates+Src; Sources—When using Intermediates, Intermediates+Src, and Sources, select a result clip that has clip history. The clips that are found are the intermediates and/or source clips associated with the selected clip.
SrcTC	A source time-code	Is Equal To; Is Not Equal To; Is Less Than; Is Greater Than; Contains; Does Not Contain
RecTC	A record time-code	Is Equal To; Is Not Equal To; Is Less Than; Is Greater Than; Contains; Does Not Contain
Date	The date the clip was last modified	Is Equal To; Is Not Equal To; Is Earlier Than; Is Later Than
Duration	The length of time of a clip	Is Equal To; Is Not Equal To; Is Greater Than; Is Less Than
Audio	n/a	Contains; Does Not Contain
Resolution	The clip's size, depth, aspect, or scan format	Is Equal To; Is Not Equal To; Is Less Than; Is Greater Than; Is Less Or Equal; Is Greater Or Equal
Soft Edit	n/a	Contains; Does not contain
Archive Date	A date and time the clip was archived	Is Equal To; Is Not Equal To; Is Earlier Than; Is Later Than; Whenever; Never
Tape	A tape name or number	Is Equal To; Is Not Equal To; Contains; Does Not Contain; Is Less Than; Is Greater Than; Matches Pattern
Comment	A comment made about the clip	Is Equal To; Is Not Equal To; Contains; Does Not Contain; Is Less Than; Is Greater Than; Matches Pattern

- 3 Optional: Enable Select Hierarchy if you want your search results to include the reel or Desktop for the clips which match your criteria.

TIP The Select Hierarchy option is useful when you archive in two passes. For example, if you archive all video material to a video archiving device and then all non-standard resolution material to another device, the structure (reels and Desktops) between archives is preserved.

- 4 Click Search to perform the search.
If a clip is found, the clip is automatically selected in the Search module. If a match is not found, the message “No matches” appears in the message bar.
- 5 Click Load to load the selected clips to the Desktop.

Organizing Clips

As clips accumulate in a clip library, you can organize them according to your needs. You can:

- Create new clip libraries. See [Creating Clip Libraries](#) on page 557.
- Create new desktop or library reels from a clip library and then move clips or other entries into the new reels.
- Sort the entire clip library, or selected entries, by name or by creation date. See [Sorting Entries in Titles and Proxies Mode](#) on page 572.
- Move entries within or between clip libraries.
- Copy entries.
- Name and rename entries.
- Delete clips and other entries that are no longer needed.
- Delete clip libraries that are no longer needed.

To organize clips, use the Library Management menu, the Dual View mode, the Clip Library box, and the Clip Library menu, as well as drag and drop functionality.

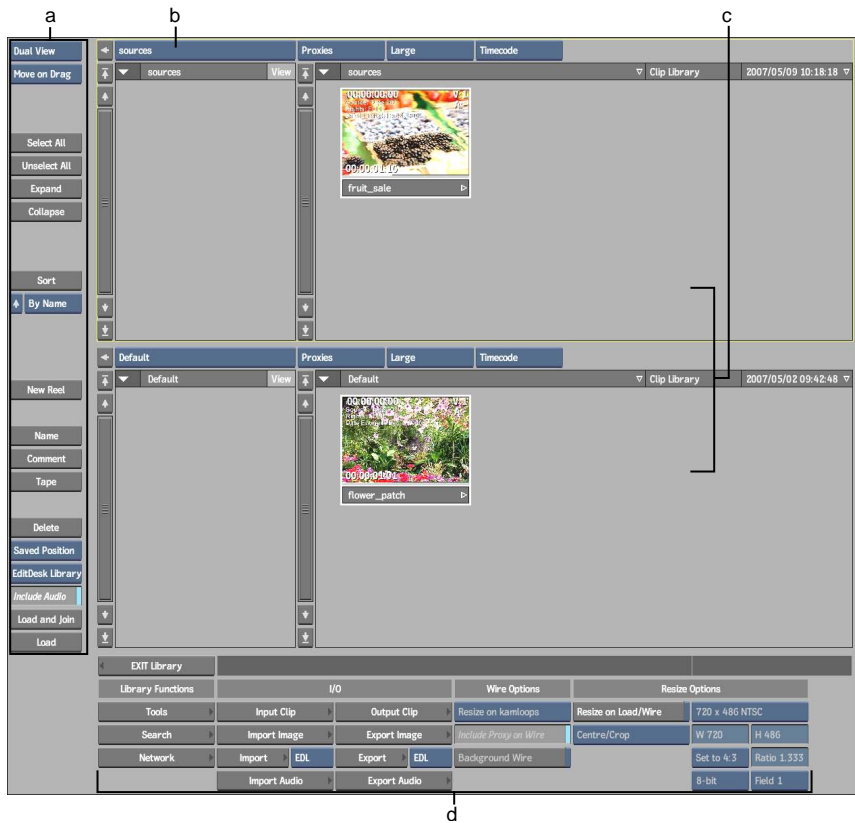

(a) Library Management menu (b) Clip Library box (c) Dual view (d) Clip Library menu

Adding Library Reels and Desktop Entries

You can add library reels or desktop entries to a clip library to use as containers when you organize clips.

To add a new library reel or desktop entry to a clip library:

- 1 From the Clip Library box, select a clip library.
- 2 In the Library Management menu, click New Reel or New Desktop. The on-screen keyboard appears.
- 3 Type a name for the new entry and press **Enter**. The entry is added to the current clip library.

Moving Entries

You can move clip library entries within a clip library, or using the Dual Library View, between clip libraries. Entries are moved using drag and drop functionality in either Titles or Proxies mode. Drag and drop a single entry or multiple entries with the left mouse button or the pen.

You can move any entry to another location as long as the library's hierarchal structure is maintained. For example, you can move a reel entry into a desktop entry, but not a desktop entry into a reel entry.

To move an entry:

- 1 In the Library Management menu, click Move on Drag.

NOTE If you press Spacebar before you select the clip, this will create a copy of the clip rather than simply moving the clip (see the “To copy an entry:” procedure in [Copying Entries](#) on page 587).

- 2 Select the clip's title bar (in Titles mode) or the name bar of the clip's proxy (in Proxies mode) and drag the entry over the new position. To select multiple clips, hold **Ctrl** while selecting the clips.

The cursor changes to a white or green four-headed arrow. When the cursor is green, the clip is in a location where you can successfully drop it. When the cursor is white, you cannot drop it at the current location. You need to move it closer to the destination.

- 3 To move a clip to a location in a library currently not displayed, hold the selected clip over the scroll arrow buttons. Alternatively, select a clip and use the keyboard arrow keys to scroll to a new location in the clip library.
- 4 Release the cursor to drop the entry. In Titles mode, the dropped clip is placed above the nearest clip. In Proxies mode, the dropped clip is placed to the left of the nearest clip. This is illustrated in the following example.

Before

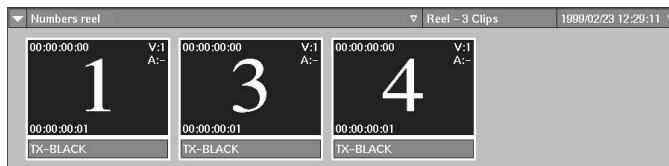

Placing the clip

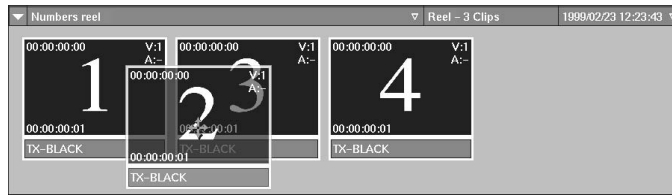

After: The clip is placed to the left of the nearest clip

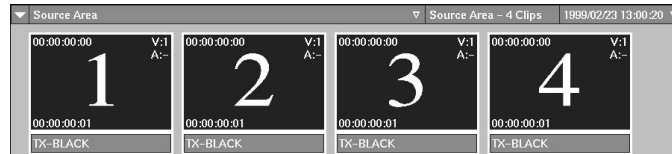

Copying Entries

You can copy clip library entries within a clip library, or using the Dual Library View, between clip libraries. Entries are copied using drag and drop functionality in either Titles or Proxies mode.

To copy an entry:

- 1 In the Library Management menu, click Copy on Drag.
- 2 Position the cursor over the entry you want to copy. When copying a clip displayed as a proxy, position the cursor over the proxy name bar.

TIP To copy multiple entries, hold **Ctrl** and select the entries.

- 3 Drag the cursor away from the original entry.
The original remains in the clip library and a copy appears under the cursor.
- 4 Drag the copy to the desired location and release the mouse button. If you have problems dropping the copy, see [Moving Entries](#) on page 586.

Renaming Entries

You can rename an entry—a clip, a reel, a desktop, or the clip library itself.

To rename an entry:

- 1 In a clip library, select the entry you want to rename.
- 2 In the Library Management menu, click Name.
The on-screen keyboard appears.
- 3 Type a name for the entry and press **Enter**.

Renaming Reels in a Clip Library

If you rename a reel in a clip library, the reel is not renamed on the desktop.

Renaming Clips in a Clip Library

If you rename a clip in a clip library and the same clip is on the desktop or elsewhere in the same clip library, the name is changed in both places. However, if you created a copy of the clip on the desktop, the name of the copy is not changed.

Renaming Clips on the Desktop

When you rename clips on the desktop, they are not renamed in the clip library unless you explicitly save the clip. For example, Clip A appears in a clip library and on the desktop. You rename Clip A to Clip B on the desktop. When you open the clip library containing Clip A, the clip retains its original name.

NOTE You cannot load a clip from a clip library to the desktop if the same clip already appears there, regardless of clip name differences. Using the previous example, if you try to load Clip A from the clip library to a reel on the desktop (where Clip B already exists), Clip B would be moved to the reel instead.

Deleting Entries from a Clip Library

Use the Delete button to delete desktops, reels, or clip entries from either a local or remote clip library.

Alternatively, you can use drag and drop operations to delete an entry.

If there are copies of a clip in the clip library, or if the clip is used in other projects that have the media stored on the same volume, the media for the clip is stored only once on the framestore, and each copy of the clip references that media. In these cases, when you delete a copy of the clip, the media is not deleted from the framestore. The media is only deleted when no other clip is referencing it.

When you delete a soft-imported clip from Autodesk storage, the media that is associated with the soft-imported clip in the shared storage area is not deleted. Conversely, if you delete media in the shared storage area, it is permanently deleted. This means that if you have a soft-imported clip in Autodesk storage that refers to media that is deleted in the shared storage area, your soft-imported clip will no longer contain media and will display as a checkerboard pattern. See [Importing and Soft-Importing Image Files](#) on page 210.

To delete selected entries:

- 1 From the Clip Library box, select the clip library from which you want to delete entries.

WARNING Do not delete the `_Edited_` clip library or any of its clips unless you are sure you no longer need your Batch setups. See [Managing Edited Clips in Batch](#) on page 1188.

- 2 In the clip library, select the entries you want to delete.

TIP If you want to select multiple entries not in a row, hold **Ctrl** while you select them. To select a range of entries, hold **Shift**. See [Selecting Entries](#) on page 580.

WARNING The following step permanently deletes the selected entries from the clip library. There is no undo function.

- 3 Click Delete, then click Confirm.
The selected entries are deleted from the clip library.

To delete an entry using drag and drop operations:

- 1 From a clip library, drag an entry to the bottom of the screen. When the green recycling cursor appears, drop the entry by releasing the pen or mouse button.

TIP You can also delete multiple entries at once with a drag and drop operation.

- 2 Click Confirm.

Deleting Clip Libraries

You can delete either a local or remote clip library using the Delete button in the Clip Library menu.

If the media associated with the clips in the library you are deleting is referenced by any clips located in other libraries, it is not deleted from the framestore. The media is only deleted when there are no other clips referencing it.

NOTE You cannot delete a clip library if it is the only one in the project. You cannot delete a library if you have read-only privileges.

To delete a clip library:

- 1 From the Clip Library box, select the clip library you want to delete.

WARNING Do not delete the `_Edited_` clip library or any of its clips unless you are sure you no longer need your Batch setups. See [Managing Edited Clips in Batch](#) on page 1188.

- 2 In the clip library, select the clip library entry. The clip library entry is the first entry. See [Selecting Entries](#) on page 580.

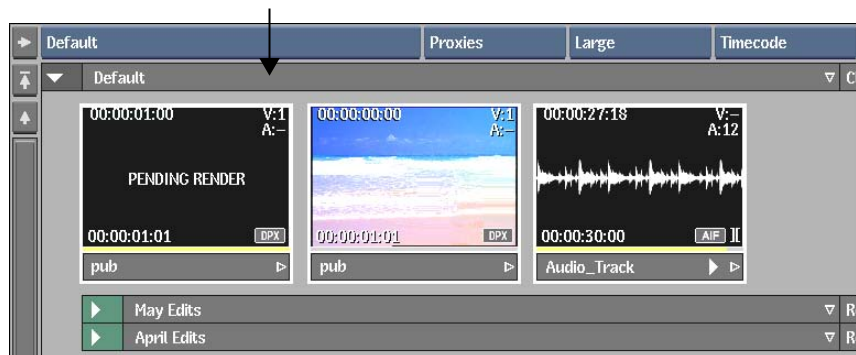

WARNING The following step permanently deletes the clip library. There is no undo function.

- 3 Click Delete, then click Confirm.
The clip library and all its entries are deleted from the framestore.

Loading Clips to the Desktop

You can load entries from a clip library to the desktop. If a clip contains audio, you can load it with its audio tracks or as video only. You can load clips from clip libraries in the current project or in other local projects. If you have Wire, you can load clips from remote projects. See [Copying Local and Remote Clip Libraries to Your Current Project](#) on page 593.

To load entries from a clip library:

- 1 In the Clip Library box on the desktop, select the clip library containing the entries you want to load.
- 2 Click Load in the Library menu.
- 3 Select a destination.

TIP A shorter method is to click the Load button of the reel you want to use as the destination.

The current clip library appears. You can change the current clip library at any time using the Clip Library box.

- 4 Select the entries you want to load to the desktop. See [Selecting Entries](#) on page 580.

The type of entry you select determines where the entry is loaded.

Select:	To:
Desktop	Load each saved clip to the same desktop reel that it was on when the desktop was saved. The destination reel is ignored. Any clips that are on the desktop when you load a saved desktop are retained.
Reel	Load all clips associated with the reel on the destination reel.
Clip	Load the clip on the destination reel.

TIP You can load entire library reels or selected source clips within soft edits. You may have to expand some parent entries to find the entries you are looking for. It is also possible to load desktops containing up to eight reels, even if the current desktop is set to fewer. The clips are loaded, but cannot be accessed unless the number of reels is increased in the Systems Preferences >Desktop Preferences menu. Load multiple entries by holding **Ctrl** and selecting the entries.

- 5 To resize the clips before loading them to the Desktop, enable Resize and set resizing parameters. See [Resizing on Import, Export, or in a Clip Library](#) on page 665.
- 6 If the clip contains audio tracks and you only want to load the video, disable Include Audio.
- 7 Click Load.
The desktop reappears with the selected entries loaded.

NOTE If a clip has proxies that do not match the project resolution, you are prompted to regenerate them. If you confirm, proxies are generated and the clip is loaded. If you abort, only clips with proxies that match the project resolution are loaded.

Clearing Desktop Reels Before Loading Clips

Use the Clear/Load button in the Clip Library menu to delete the destination before loading the selected entry. For example, if you are loading a reel entry, the destination reel is deleted before the reel is loaded.

WARNING Since the Clear/Load command will delete the desktop, use this command with caution.

To clear the desktop or a reel when you load clips:

- 1 In the Library menu, click Load, and select a destination reel.
- 2 In the clip library that appears, select the clip, reel, or desktop that you want to load.
- 3 Click Clear/Load.

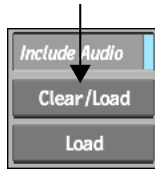

The clips are loaded to the desktop. If you loaded a desktop, the clips that were previously on the desktop are cleared and the selected clips are loaded to the desktop. If you loaded a clip or reel, the reel you selected is cleared and the selected clips are loaded to a reel.

Loading and Resizing Clips

When you load clips to the Desktop, you can change their resolution, bit depth, aspect ratio, and positioning using the Resize tool in the Clip Library menu. You can resize clips from clip libraries in the current project or from clip libraries in other projects.

To load and resize clips:

- 1 Enable Resize in the Clip Library menu.
- 2 Use the Resize options in the Resize menu to resize your clips. See [Resizing on Import, Export, or in a Clip Library](#) on page 665.
- 3 Click Load.

The Desktop appears with the selected entries resized and loaded.

Copying Local and Remote Clip Libraries to Your Current Project

You can access the clip libraries residing in local or remote projects in order to share clips. When you want to use clips belonging to another project, copy and save them to a library belonging to the current project.

Use the network library to select the clip libraries that you want to access (that is, the clip libraries you want to appear in the Clip Library box on the Desktop). You can access the clip libraries of any project on any local volume (such as `stonefs` and `stonefs1`), and, if you have Wire, you can access projects on remote framestores. All available framestores are listed in the network library in alphabetical order, following the host machine.

When you load clips from another project, the clip metadata is always copied to the current project. The media itself is not copied if it is located on the same volume as the current project. In this case the media is shared between the two projects. Media is only copied when you are loading from:

- Another volume on the same framestore or from another framestore.
- A project created in an older version of an Autodesk product for which the clip format is incompatible. See [Upgrade Compatibility](#) on page 10.

WARNING If a remote framestore is shut down while you are accessing it, you will lose access to the libraries on the remote framestore and your system may freeze. Clips loaded from the remote framestore are unaffected when the remote framestore is shut down.

To access the network library:

- 1 In the Main menu, click Library.
- 2 In the Clip Library menu, click Network.

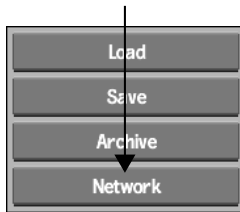

The network library appears.

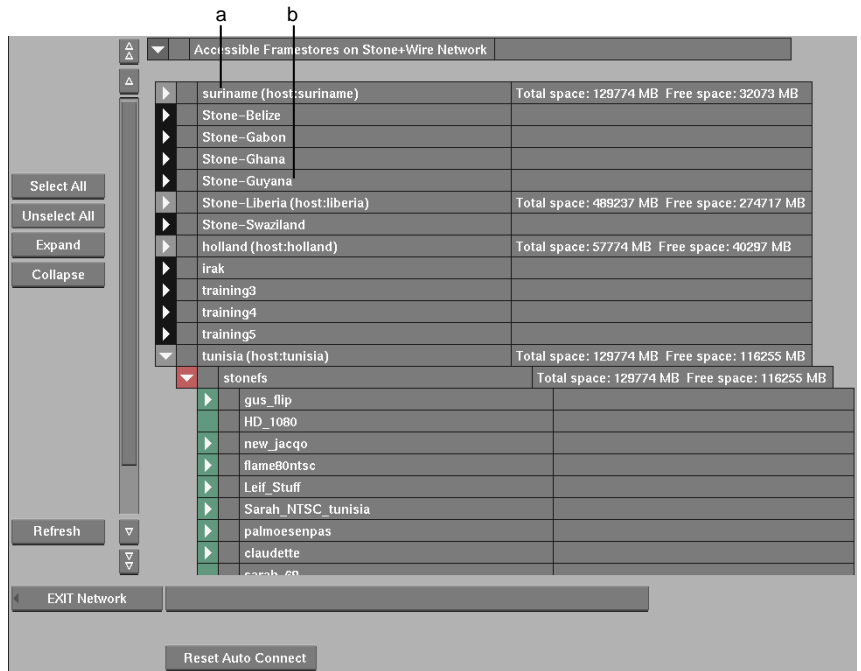

(a) Local system (b) Remote system

The local system is listed at the top of the network library. Remote systems follow in alphabetical order.

The network library controls are described as follows.

Select All and Unselect All buttons Click Select All to select all entries in the network library. Click Unselect All to unselect all entries.

Expand and Collapse buttons Click Expand to expand selected entries. Click Collapse to collapse selected entries. When you click the Expand button beside a framestore entry, the host machine is shown in parenthesis.

TIP You can also click the Expand and Collapse arrows at the left of an entry to expand and collapse it.

Refresh button Updates the list of systems by probing all systems in the list to see if they are still accessible, and selected systems only to check if clip libraries have been added or deleted from other workstations.

NOTE Systems are automatically refreshed when you expand an entry.

Reset Auto Connect button Disconnects all entries set for auto-connection.

Network Library Structure

The network library has a similar structure to a clip library. For example, the hierarchical relationship among groups of available remote systems, projects, and clip libraries is represented using indentation. All available framestores are listed alphabetically with the exception of the local framestore, which appears first.

Network Library Entries

The network library can contain the following entries.

Entry:	Contains:
Framestore (local or remote)	An entry for each volume on the framestore. When you expand a framestore entry in the network library, all its volumes are queried and the name of the host machine appears in parenthesis to the right of the framestore name.
Volume	An entry for each project in the volume.
Project	An entry for each clip library in the project.
Clip Library	No child entries.

The colour of the box at the far left of the entry indicates the type of entry.

The colour:	Represents:
Black	Framestore.
Light Grey	Accessed framestore.
Red	Framestore volumes.
Green	Projects.
Dark Grey	Clip libraries.

Selecting Clip Libraries in Local or Remote Projects

To make a clip library in a local or remote project accessible, select it in the network library. You can make local or remote clip libraries available for the current work session only, or each time you load the application.

To select a clip library in a local or remote project:

- 1 Display the Network Library menu.
- 2 Click Refresh.
All accessible projects are searched for on local and remote framestores.
- 3 Expand entries as needed to see the available projects or clip libraries. To view all entries, click Select All, then Expand. Next, click Unselect All and make individual selections.
All accessible remote clip libraries appear.
- 4 Select the clip libraries you want to access. The procedure for selecting entries is the same as that used in clip libraries. See [Selecting Entries](#) on page 580.
Selected entries are light grey.

TIP Select a framestore entry to access all libraries on the remote system; select a project entry to access all libraries in that project.

- 5 To automatically reconnect to a framestore, volume, project, or clip library when you restart the application, click the grey box to the left of the entry.
The letters AC appear in the box, indicating the entry is set to be reconnected. All entries belonging to the entry are also set. When you restart the application and load the project, the specified entries are connected and the associated clip libraries are available in the Clip Library box.

NOTE A green AC indicates that the entry and all subentries are set for auto-connection; a yellow AC indicates that some but not all subentries are set for auto-connection.

- 6 If you want to stop automatically reconnecting to the clip libraries associated with an entry, click the grey box next to the entry again. To disconnect all entries set for auto-connection, click Reset Auto Connect. The AC indicator disappears.

- 7 Exit the Network Library menu.

All the clip libraries you selected in the network library are listed in the Clip Library box along with the project's clip libraries. All clip libraries set for auto-connection will be available when you restart the application.

Disabling Auto-Connect from Outside the Application

Occasionally, a problem with a remote system that is auto-connected to your project can prevent Flame from loading. When this happens, the local system will freeze as you try to launch it and a message will appear in the shell indicating which remote system is unreachable. If this occurs, you can kill the application and then temporarily disable auto-connect using the following procedure.

To temporarily disable auto-connect:

- 1 In a command shell, where you plan to launch the application, type:

```
setenv DL_NETWORK_NO_AUTO_REIMPORT
```

When you launch the application, the current configuration of auto-connected remote systems is not loaded.

NOTE The next time you launch the application without using this environment variable, the auto-connected remote system is once again loaded.

Copying Clips from Other Projects

You can copy clips to your project from other projects on the same system or from projects on other systems. When you copy clips from projects on other systems you use Wire.

As you copy clips from other projects on other systems, you can:

- Copy proxies from the source project into the destination project. Proxies can be copied if both the source and the destination projects have the same proxy settings. This relieves the destination system of having to generate proxies. In most cases, transferring proxies using Wire is significantly faster than generating them.
- Resize the clips on the source or destination system.

- Perform all tasks in the background so that you can continue to work in your application while the clips are copied.
Background Wire transfers are managed by Backburner. Before you can transfer clips in the background, edit the *manager.hostfile* located in `/usr/discreet/backburner/cfg`. You must also edit the Backburner hostname, priority, and group keywords in the *init.cfg* file. Refer to the *Autodesk Visual Effects and Finishing Configuration File Reference Guide* for details on editing the *init.cfg* file.

To copy clips from projects on the same system:

- 1 Open the clip library in Dual Library View.
- 2 In one view, navigate to the project that contains the clips you want to copy.
- 3 In the other view, open the clip library where you want to copy the clips to.
- 4 Drag and drop the clips you want to copy into the destination project.
The clips are copied to the destination system.

To copy clips from projects on other systems:

- 1 Open the clip library in Dual Library View.
- 2 In one view, navigate to the remote framestore and display the clips that you want to copy.
- 3 In the other view, open the clip library where you want to copy the clips to.

In the Wire Options area, several buttons become active, depending on your setup.

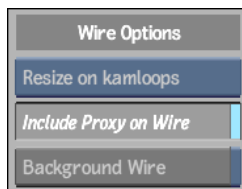

- 4 If you have Backburner set up, decide if you want to perform tasks in the background.
 - To perform tasks in the background so that you can continue working in the application, enable the Background Wire button.

- To perform tasks in the foreground, disable the Background Wire button.
- 5 Decide if you want to perform the resize on the destination or source system.
 - To perform the resize on the source system, disable the Resize button.
 - To perform the resize on the destination system, enable Resize.
 - 6 Decide how you will handle proxies. Do one of the following:
 - To transfer proxies using Wire, enable the Include Proxy on Wire button.
 - To generate proxies on the destination system, disable the Include Proxy on Wire button.
 - 7 Drag and drop the clips you want to copy into the destination project. The clips are copied to the destination system.

If you chose to copy your clips as a background task, you can monitor the progress of your transfer. Press **F11**. The Background I/O window appears. You can also use Backburner Web or Windows monitor to track the progress.

Aborting a Wire Transfer

To abort a transfer of video or audio clips using Wire, click the mouse button or tap the pen on the tablet and click Confirm.

WARNING If you interrupt a load or save operation with the abort command, clips that have already been transferred remain transferred; clips that have not been transferred are not.

Troubleshooting Lock Files

When a process accesses a file, it attempts to get a lock on the file so that it can have Write, as well as Read, access. (A process can be your Visual Effects and Finishing application or a remote application transferring media over Wire.) When a file is locked by one process, no other process can write to that file, which ensures that files do not get corrupted or accidentally overwritten by multiple users.

When a process finishes working on a file, it releases the lock so that other processes can get Write access. However, if the process is unable to release the file because of a problem, that lock file will remain and will prohibit other processes from getting a lock, even if the process is not using the file.

If you can't get Write access to a file, use the following procedure to locate the lock file and check to see if the file is legitimately locked. If the file is not locked by an active process, you can delete the lock file so that another process can get Write access.

To evaluate lock files:

- 1 Open the clip directory */usr/discreet/clip* and locate the lock files:

```
find . -name '*-lock'
```

The command returns results similar to the following example:

```
./burnBat/SNA.clib-lock  
./wiretap/Default.clib-lock
```

This example indicates that there are two lock files.

- 2 Determine what processes have locked the files. Type:

```
ls -l ./burnBat/SNA.clib-lock
```

This command returns results similar to the following:

```
lrwxrwxrwx 1 root users 19 Jun 15 09:14 ./burnBat/SNA.clib-lock ->  
172.16.129.53:16488
```

In this example, the IP address of the machine that is running the process and the ID of the process are provided at the end of the line. In this example, the IP address is 172.16.129.53 and the process ID is 16488.

- 3 To determine if that process is still running, log in to the machine where the process was running. Then use the ID to determine if the process is running. Type:

```
ps -e | grep <process_ID>
```

Using the process ID from the previous example, this command would look like:

```
ps -e | grep 16488
```

This command has two possible results:

- If the command returns nothing, it indicates that the process is not running and the lock file is not necessary.

After you have determined that no process has locked a file, you can delete the lock file.

- If the command returns a process name, you know that a process is running and has locked the file. You can't delete the lock file without jeopardizing someone else's work.

Topics in this chapter:

- [About Archiving](#) on page 604
- [Choosing a Medium for Archiving](#) on page 604
- [Supplementing Archives with System Drive Backups](#) on page 606
- [Archiving and Restoring Mixed Resolution Projects](#) on page 608
- [Media Archiving Workflow](#) on page 609
- [Project Setup Archiving Workflow](#) on page 610
- [Configuring Hardware](#) on page 610
- [Configuring Software](#) on page 612
- [Accessing the Archive Menu](#) on page 613
- [Estimating Archive Size](#) on page 615
- [Creating a VTR Archive](#) on page 618
- [Creating a Tape Archive](#) on page 625
- [Creating a File Archive](#) on page 627
- [Archiving Soft-Imported Clips](#) on page 629
- [Archiving to Multiple Tapes](#) on page 630
- [Opening an Archive](#) on page 631
- [Saving to an Archive](#) on page 634
- [Closing an Archive](#) on page 640
- [Managing Archives](#) on page 641
- [Browsing an Archive](#) on page 642
- [Searching in an Archive](#) on page 647
- [Appending Entries to an Existing Archive](#) on page 648
- [Deleting Entries from an Archive](#) on page 649

- [Archive Compatibility](#) on page 649
- [Setting Preferences When Restoring Archives from Previous Versions](#) on page 650
- [Recovering an Archive](#) on page 653
- [Archiving and Restoring Setups](#) on page 655
- [Optimizing Archiving Operations](#) on page 657

About Archiving

Archiving in Flame provides an efficient way to save your media and project setups on external storage devices or in a filesystem. This frees up space for new projects. It is also a convenient way to store your projects offline in a fully restorable form, both long- and short-term.

Archive complete projects including project settings, configuration files, setups, and libraries (all the items that are stored in the project directory). In addition to archiving complete projects, you can archive clip libraries and individual elements of clip libraries.

Choosing a Medium for Archiving

Choosing a medium or device for your archiving needs largely depends on your technical resources and overall needs. There are certain advantages and disadvantages to using each medium/device.

There are three basic types of archiving devices/media supported in Flame: VTRs, tape drives, and file systems.

VTRs

Using a VTR to archive your material is an inexpensive and accessible way of storing archives. VTRs are easy to patch and tapes can store large amounts of media, and VTR archives are viewable outside of Autodesk Visual Effects and Finishing applications. However, you can only archive clips whose format matches that of the VTR, and you cannot archive 12-bit material. As a long-term archiving medium, VTR tapes are subject to physical deterioration and format obsolescence.

You can use the following VTRs for archiving your material in Flame:

- Uncompressed SD VTRs such as D-1 or lightly compressed SD VTRs such as Digital Betacam
- Uncompressed HD VTRs or lightly compressed HD VTRs such as Sony HDCAM SR or Panasonic HD D5
- Compressed HD VTRs such as Sony HDCAM (using "HDCAM" rather than "VTR" as the archive device type)

Tape Drives

Using a tape device for archiving purposes allows for fast archiving and restoring. Tape drives are inexpensive and readily available. Tape provides fast and reliable read and write performance. However, data archives (tape archives) can only be restored to a Visual Effects and Finishing workstation and are unreadable by other applications. Also, magnetic tape is a delicate media and is greatly affected by environmental conditions that cause its deterioration. The procedure of archiving to a tape device is similar to archiving to file.

Visual Effects and Finishing workstations only support DTF2 fibre channel tape devices connected to ports 1 or 4 of a four-port fibre channel adapter.

NOTE When archiving with the Sony DTF2, use firmware version 1.41.

Other fibre channel devices that may work are those for which the vendor confirms that:

- The device driver is compliant with standard UNIX tape device calls.
- The specific version of your operating system and kernel is supported.

While Autodesk Media & Entertainment makes no certification statement about any device, the following SCSI devices have been tested and found to be reliable when connected using an ATTO Fibre Channel to SCSI Bridge 2390:

- Quantum LT03
- Quantum DLT8000
- Quantum DLT7000
- Sony AIT3 SDX-D700C
- Sony AIT2

The initialization file (*init.cfg*) for your Visual Effects and Finishing 2007 application contains examples of the ClipMgtDevice Tape keyword to help you set up the appropriate block size value for your tape device and define a text label to identify the device in the Archiving module. Please refer to the documentation from your archiving device vendor for guidelines on the actual block size to use.

File Systems

Using a file system to archive your material provides the quickest method of archiving and restoring your material, and offers full support for mixed-resolution projects. However, archiving large projects may require a significant amount of local or networked storage hardware. As the storage hardware features and capabilities evolve, using external USB 2.0/FireWire® (IEEE 1394) hard drives offers a cheap alternative for archiving smaller projects or projects that require portability. These devices can be formatted as ext2, ext3, or Mac® file systems. NTFS is not supported. External USB 2.0/FireWire® devices can be used.

Supplementing Archives with System Drive Backups

The recommended backup strategy for your Visual Effects and Finishing workstation is to archive project media and setups to a Video device, or as a data file that can be saved to a remote file server or storage device. Do this as often as necessary to protect your media from unlikely storage or system failure.

The archiving approach, however, does not protect the data contained on your workstation's system drive, nor does any other tool provided by Autodesk Media & Entertainment. The system drive does not contain any media data, but it does include important project management data. In the event of hardware failure without a system drive backup, you will need to recreate this project data for each archive you restore. This can be a time-consuming and frustrating process, and is a significant issue in large SAN environments, where large quantities of media files are referenced from a shared standard FS volume. In such environments, consider using the data backup method of your choice to save key system drive information. This will facilitate restoration of multiple project archives.

Even with a system drive backup, you will still need to reinstall your Visual Effects and Finishing application and restore archived projects in the event of a system drive failure.

There are several methods and commercial tools available for backing up system drives. Choose the method and tool that is right for you. Autodesk does not recommend any particular method or tool, and only presents the directories of note that you should consider backing up. Depending on your requirements and available tools, you may decide to back up your full system drive or only the following critical files or directories.

File/directory	Purpose	Consequence of failure if system drive is not backed up
/usr/discreet/clip	Contains all clip metadata.	Metadata will have to be recreated for each valid archive that is restored.
/usr/discreet/project	Contains full project structures, including settings such as names, resolutions, user information, and so on.	Project settings will have to be recreated for each valid archive that is restored.
/usr/discreet/sw/swdb	Contains the standard FS links database.	Media on a shared SAN volume will have to be re-imported.
/usr/discreet/sw	Contains all Stone and Wire software and configuration files, including the preceding directory, swdb.	Storage and Wire settings will have to be reconfigured after installation.
/usr/discreet	Contains your Visual Effects and Finishing software, as well as all other directories described in this table.	See consequences for all previous items. Back up this directory if you want to be sure to restore all critical data, and do not mind including some superfluous files (such as old unused versions of the application.)

WARNING In addition to backing up the preceding directories, you must also regularly archive your material. In other words, even if you back up the preceding critical directories, you will not be able to restore your projects unless you previously archived them. Without project archives, all media and projects will be lost in the event of a system drive failure.

The backup strategy suggested here only covers files that are critical to your Visual Effects and Finishing application. For information on backing up the Linux operating system, see your Redhat documentation, or contact Redhat technical support.

To backup critical Visual Effects and Finishing files from your system drive:

- 1 Close your Effects or Finishing application.
- 2 Stop Stone and Wire. Type:
`# /etc/init.d/stone+wire stop`
- 3 Back up some or all of the directories listed in the preceding table using the method and tool of your choice.
- 4 Start Stone and Wire. Type:
`# /etc/init.d/stone+wire start`

Archiving and Restoring Mixed Resolution Projects

Generally, archiving to data tape or filesystem are easier ways for archiving mixed-resolution projects, as clips of any resolution can be archived on the same medium. It is also possible to archive multiple-resolution projects to a VTR. This operation, however, may require multiple tapes with different timing corresponding to each segment resolution. Alternatively, you can use the Unlink tool to unlink media from clips of any resolution, archive unlinked clips, and then relink the media at restore time. See [Unlinking Media from Clips in the Clip Library](#) on page 270.

NOTE Before starting to archive a mixed-resolution project to a VTR, make sure you have enough tapes matching each resolution used in your project.

Archiving Clips Containing Sources with Different Bit Depths

If you want to archive a clip that contains sources with different bit depths, archive the clip to file or data tape. To archive the clip to a VTR, you must convert all sources to the same bit depth (less than 12).

NOTE IBM 6224 systems support a bit depth of 8 bits only.

8- and 10-bit VTR Archiving

A VTR archive can contain 8- or 10-bit clips—although all clips in the archive must have the same bit depth. When archiving 8-bit material to 8- or 10-bit VTRs, the clip metadata remains in an 8-bit format.

You can archive 10-bit material to 8- or 10-bit VTRs. However, when archiving 10-bit material to an 8-bit VTR, you reduce the quality of the archived material. A warning message appears notifying you of the downgrade. 10-bit clips archived to 8-bit format are flagged as such in the archive. Similarly, when archiving 12-bit material to 8- and 10-bit VTRs, a warning message appears, and the 12-bit clips are flagged in the archive. You cannot restore downgraded clips to their original bit depth.

Before archiving to any device in Flame, you can perform archive size estimation. See [Estimating Archive Size](#) on page 615. Before proceeding, make sure you have enough tapes ready. You can perform size estimation before archiving to a filesystem to make sure you have enough space on disk.

Media Archiving Workflow

There are several ways to archive. Depending on the archiving device that you choose, the steps might differ slightly. The basic workflow is as follows.

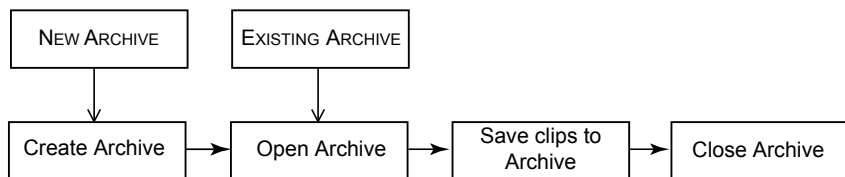

To archive a project:

- 1 Make sure all hardware devices involved in the archiving process are properly configured. See [Configuring Hardware](#) on page 610.
- 2 Make sure keywords related to the archiving process are properly configured. See [Configuring Software](#) on page 612.
- 3 Access the Archive menu. See [Accessing the Archive Menu](#) on page 613.
- 4 Create an archive. See [Creating a VTR Archive](#) on page 618.
- 5 Open the archive. See [Opening an Archive](#) on page 631.
- 6 Save clips to the archive. See [Saving to an Archive](#) on page 634.

- 7 Close the archive. See [Closing an Archive](#) on page 640.

Project Setup Archiving Workflow

You can archive project setups to the filesystem. This procedure requires no dedicated hardware—but only a filesystem destination for a *.tar* file. When you archive setups, your project home directory, including images and audio files in the *images* and *audio* directories, are saved.

To archive a project setup:

- 1 Make sure keywords related to the archiving process are properly configured. See [Configuring Software](#) on page 612.
- 2 Access the Setups Archive menu. See [Accessing the Archive Menu](#) on page 613.
- 3 Save setups to the archive. See [Saving to an Archive](#) on page 634, and [Archiving and Restoring Setups](#) on page 655.

Configuring Hardware

Many problems encountered during archiving processes are caused by improper hardware configuration. Before you proceed archiving your project, make sure you have performed all the initial steps to set up and configure your hardware.

Configuring a VTR for Archiving

Before you start archiving to a VTR, make sure that:

- Your VTR device is properly connected to video and audio sources and RS-422.
- The sync is properly set up.

Configuring Tape Devices for Archiving

When archiving to tape devices, you must perform certain steps to ensure smooth operation.

Setting the Block Size for a New Tape Archive

When you enter the Archive menu and format a new tape archive, the default block size matches the value in the Block Size field in the Format menu. Keep track of the block size value for each tape in case you need to reset the block size at a later time.

To verify the block size of your tape device:

- 1 In a command shell, log in as root.
- 2 Verify the block size of your tape device by typing:
`mt -f /dev/st<archive device number> status`

Example:

```
mt -f /dev/st0 status
```

This command provides feedback similar to the following:

```
SCSI 2 tape drive:
File number=0, block number=0, partition=0.
Tape block size 65536 bytes.
Density code 0x40 (DLT1 40 GB, or Ultrium).
Soft error count since last status=0
General status bits on (41010000):
BOT ONLINE IM_REP_EN
```

Determining the Device Number for the Archive Device

If you receive an error message when verifying the block size, you may not be using the correct archive device number. Look in the software initialization configuration file to determine the correct number.

To determine the archive device number:

- 1 In a terminal, type:
`dlcfg`
- 2 Look for the line that begins with the following:
`ClipMgtDeviceTape, /dev/st<archive device number>`

The archive device number should be listed on this line. If it is not, or appears to be incorrect, consult the administrator for your system.

Resetting the Block Size for an Existing Tape Archive

If you rebooted the machine or reformatted another archive with a different block size, you must reset the block size for your archive in the command shell.

To reset the block size of your tape:

- 1 In the command shell, log in as root.
- 2 Set the correct block size by typing:

```
mt -f /dev/st<archive device number> defblksize  
<block size of your tape device>
```

Example:

```
mt -f /dev/st0 defblksize 4096
```

The block size for your tape is reset and you can continue to archive to this tape.

Configuring Software

Before you start Flame to perform archiving, edit the software initialization configuration file to enable VTR, data tape, or file archive devices in the CLIPMGTDVICE keyword section. You must also enable any VTRs that you plan to use in the VTR keyword section.

The devices that you enable in the software initialization configuration file will be available in Flame when you start the application. See the *Autodesk Visual Effects and Finishing Configuration File Reference Guide*.

To properly configure your software for archiving, follow the instructions in the following sections of the software initialization configuration file:

- VIDEO KEYWORD
- VTR KEYWORD
- CLIPMGTDVICE KEYWORD
- MAXLIBRARYSIZE KEYWORD
- ARCHIVELIBRARY KEYWORD

- SETUPARCHIVETAPE KEYWORD

Accessing the Archive Menu

You can use the Archive menu to:

- Select an archiving device.
- Format an archive.
- Open an archive to save or restore clips or setups.

To access the Archive menu:

- 1 In the Main menu, click Library.
- 2 In the Library menu, click Archive.

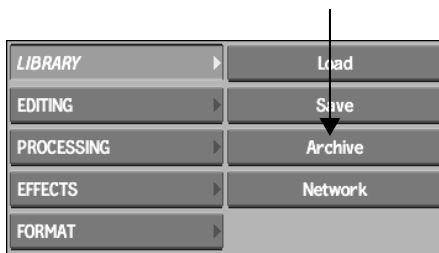

The Archive menu appears.



(a) Archive Device box (b) Size Estimate button (c) Device Name box

Archive Device box Lists all available types of archive device. If the device type you want to use is not listed, uncomment the appropriate line in the

software initialization configuration file in the CLIPMGTDDEVICE KEYWORD section. See the *Autodesk Visual Effects and Finishing Configuration File Reference Guide*.

Device Name box Lists all archive devices of the type specified in the Archive Device box. This box is displayed for VTR and Tape devices other than DST. It is not displayed when only one device of a given type can be specified in the software initialization configuration file.

Size Estimate button Click to get an approximate size of entries to be archived. The resulting value appears in the Size Estimate field.

Archive Structure

The first entry of an archive is the archive itself. The archive entry is the parent entry for all other entries. Entries within the archive are structured in the same way as entries in a clip library. Indentation is used to indicate the parent and child relationship among the entries.

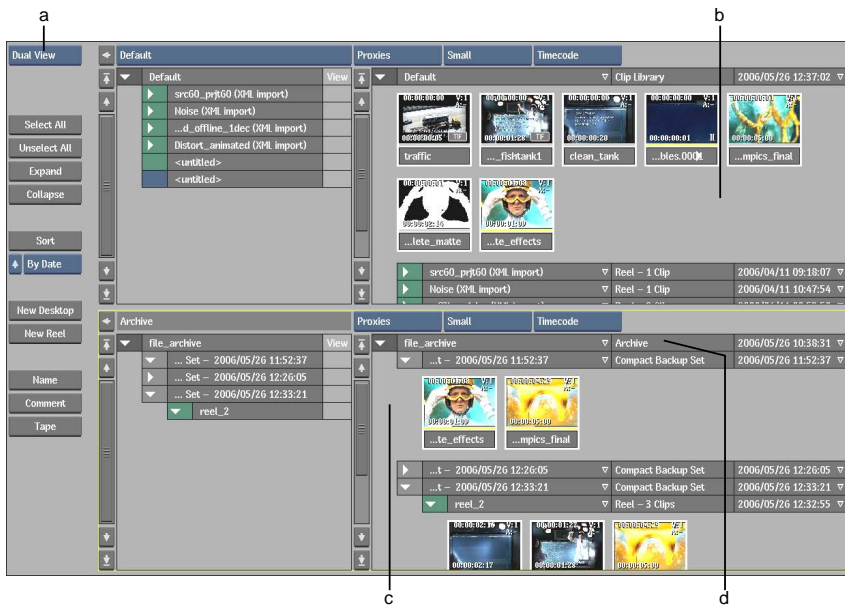

(a) Library View Mode button (b) Clip Library area (c) Archive area (d) Archive entry

Images courtesy of Technicolor (formerly Toybox) and Das Werk

Similar to a clip library, you can select, expand, and collapse entries in an archive. See [Viewing Entries in Clip Libraries](#) on page 564. Click the Library View Mode button to toggle between single and dual view. Dual view allows you to view your archive alongside any of your clip libraries. You cannot, however, move entries between clip libraries and archives, as you would between two clip libraries.

Estimating Archive Size

You can display an estimate of the media space needed to archive selected material. The size estimation display for archiving or restoring procedures shows the file size in bytes, megabytes, gigabytes, or terabytes, depending on the file size. The space required is displayed in units appropriate for the archiving device. For example, when archiving to a VTR, the archive size is estimated both in VTR time (hh:mm:ss:ff) and in the most appropriate file measurement units (megabytes, gigabytes, or terabytes). When archiving to file or a tape device, file size in VTR time is not displayed. The size estimate takes header information into account.

The space required to archive material varies by archiving device. The following factors also influence the amount of space required for an archive:

- Storing clip history with the archived clip increases the amount of required space.
- Including audio and metadata with your archive increases the amount of required space.
- Selecting Compact archives reduces the amount of required space compared to Normal archives.

There are two types of size estimation, differing in the level of detail. When you wish to get a rough estimate of the size of your material and space required for its archiving, you can perform the following procedure.

To estimate archive size:

- 1 In the Library menu, click Archive.
- 2 In the Archive menu, select the device type from the Archive Device box.
- 3 If your selected device is a tape device or VTR, from the Device Name box, select the corresponding device.
- 4 Click Size Estimate.



The clip library appears.

- 5 Select one or more clips in the clip library.
- 6 Click Size Estimate near the bottom of the screen, to the right of the search controls.

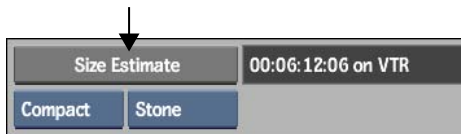

The estimate appears in the field next to the button in VTR time or in the most appropriate file measurement units.

NOTE The VTR size estimate includes a reservation of one minute for both the header data and slates. It reserves 5400 frames (3 NTSC minutes) for the header data and slates, as well as the gap between the header data and the archive, which results in at least five additional minutes.

Once you open an archive or create a new one, you can use another archive size estimation method, which provides a variety of controls to perform a more accurate file size estimation procedure.

To estimate archive size from the Desktop:

- 1 Open an existing archive or create an archive.
The Archive menu appears.

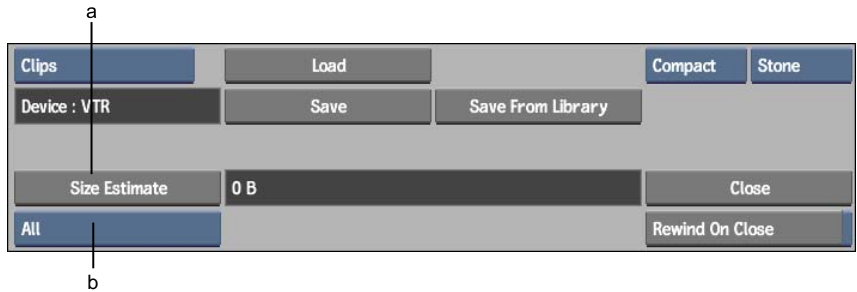

(a) Size Estimate button (b) Clip Element box

2 From the Clip Element box, select the required option.

Select:	To estimate the size of:
All	Metadata, audio, and video
Metadata	Metadata only (including history and settings)
Audio	Audio only
Video	Video only

3 Click Size Estimate.

The cursor turns into a red arrow and the Entry Type box appears.

4 From the Entry Type box, select the required option.



Select:	To estimate the size of:
Project + Shared	Project Desktop, setup directory, clip libraries, shared clip libraries, and metadata
Project	Project Desktop, setup directory, clip libraries, and metadata

Select:	To estimate the size of:
Project Libraries	Current project clip libraries
Project Libraries + Shared	Current project clip libraries and imported (shared) clip libraries
Clip Library	Current project clip library
Desktop	Current Desktop
Reel	Selected reel
Clip	Selected clip

The resulting size estimation value appears in the field next to the Size Estimate button.

- 5 If you selected reel or clip, the cursor turns into an arrow.
- 6 Click on the desired reel or clip and read the resulting size estimation value.

Creating a VTR Archive

You can create a VTR archive for clips of any resolution supported by your video board and VTR device. To archive and restore at a particular resolution, you must specify the appropriate video timing, which sets the resolution and framerate for the video board. When you change projects without exiting Flame, the video timing selected at start-up applies to the project you are switching to.

Archives must be written to tapes striped with non-drop-frame timecode. However, media with drop-frame timecode can be written to non-drop-frame timecode tapes, as long as the framerate of the timecodes match.

Before You Begin

Perform the following preparatory steps:

- Prepare striped tapes for each resolution. The tapes must be striped continuous non-drop-frame timecode.

- If the tapes already have material on them, figure out the start timecode for the archive.
- Determine if your archive requires multiple tapes.
- Make sure your VTR is in TC (Time Code) timer mode.

Selecting a Device

Only those VTRs with a timing that matches the video timing are available for use in the Archiving menu. When you want to archive or restore clips of multiple resolutions in one project, enable the VTR lines in the VTR keyword of the configuration file for all the resolutions you use on the project. This way, each time you change the video timing for archiving, the compatible VTRs are available in the Archiving menu.

When you archive to a VTR, only clips with a resolution compatible with the selected VTR device are archived. If you select a set of clips of differing resolutions, only the compatible clips are archived. Clips that are not compatible are greyed out in the library.

HD Board 1080 Line Video Timings (HD Configurations Only)

If you are working with an HD board and you selected the 1920x1080 video timing option in the Video Timing box when you started your project, you should specify the exact 1080 line video timing (including framerate) that you are using in the 1080 Video Timing box in the Engineering menu. See [Setting Video Input and Output Engineering Menu Controls](#) on page 175.

NOTE If you selected “No VTR Selected” in the Video Timing box, you must specify the video timing using the 1080 Video Timing box.

Archiving to the HDCAM SR device

The HDCAM SR device supports 4:2:2 and 4:4:4 archiving. The options required in the Engineering menu are as follows.

Input and Output Connection	Colourspace
In Serial 4:2:2 / Out Serial 4:2:2	YCrCb-->RGB

Input and Output Connection	Colourspace
In Serial Dual 4:4:4 / Out serial Dual 4:4:4	No Conversion

When you switch between 4:2:2 and 4:4:4 options, the Colourspace option changes automatically to ensure the proper settings.

Archiving to a Tape Containing Material

You can create a VTR archive on a tape that already contains material or add material to an archive on a tape. For example, on a 60-minute tape, you could allocate 20 minutes to an archive by setting its start timecode at 01:00:00:00 and defining the length of the archive as 20 minutes in the Length field. See [Creating a VTR Archive](#) on page 618. You can then add any material, starting after 01:20:00:00.

Header Information Slate

All VTR archives contain a Header Info Slate, which is a single frame providing information about the archive. Located in the archive before the table of contents, the Header Info Slate provides information such as:

- Name of the archive
- Name of the OTOC
- Name of the workstation where the archive was created and name and version of the Autodesk application used for archive creation
- Start timecode
- Creation date and time
- Modification date and time
- Minimum size of the clip library buffer (in MB) required to restore the archive

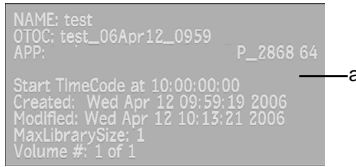

(a) Header Info Slate example

To create a VTR archive:

- 1 Open the Archive menu.
- 2 In the Archive menu, select VTR from the Archive Device box.
The options for archiving to a VTR device appear.

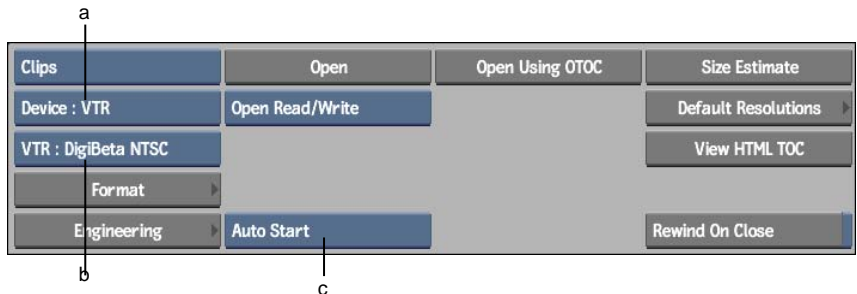

(a) Archive Device box (b) Device Name box (c) Auto/Manual Start button

- 3 Select a VTR device from the Device Name box.
- 4 Insert a striped tape with continuous non-drop-frame timecode in the VTR.
- 5 Click Engineering and set Engineering options, then return to the Archive menu. See [Tips for Better VTR Archiving](#) on page 623.

NOTE When you open an archive in read/write mode, play delay and pre- and postroll values are verified and set in the auto test run before archiving begins. Therefore, you do not need to set these options.

- 6 If you want to set the start timecode for the archive, toggle the Auto/Manual Start button to Manual Start and enter a timecode.
The start timecode that appears by default is set in the software initialization configuration file.

7 If the tape already contains material, determine the start timecode for the archive by playing the tape in the Input Clip module. See [Using the VTR Transport Controls](#) on page 173.

8 Click Format.

The Format menu appears.

Format	Name: My_Archive
	Comment:
	Length 34 mins
Manual Start	01:00:00:00

(a) Name field (b) Length field (c) Comment field

9 Enter the name for the archive entry and any additional comments in the Name and Comments fields.

10 Enter the available space after the Start Time Code in the Length field. Enter the length in minutes.

NOTE If you create the archive on a tape that already contains material, make sure you define the length of the archive as the space you want the archive to use, not the length of the tape.

11 Click Format and then Confirm to continue.

The new archive is created on the VTR tape and opens automatically. Save the contents of the current project, clip libraries, Desktop, or reels. See [Saving to an Archive](#) on page 634.

TIP Write down the archive name and creation date on the tape label. This will help you to locate the appropriate table of contents file if you need to restore your archive.

Tips for Better VTR Archiving

Use the following tips to get better results when archiving to a VTR tape:

- Set the system reference of the VTR to External Analog.
- Track the VTR to get the best RF (Reference) value and error-rate level. If your VTR has an auto-tracking feature, disable it and track manually, or place it on “one shot.”
- Click the Engineering button and check the following Engineering menu settings:
 - Timecode type: Make sure the VITC & LTC timecodes are the same. If they are not, set timecode type to LTC.
 - Input format and sync: Make sure that input format and sync match the device.
 - Output format and sync: “House” is the recommended output sync.
 - The required Scan Mode option is F1.

See [Setting Video Input and Output Engineering Menu Controls](#) on page 175.

Creating an HDCAM Archive (HD Configurations Only)

You can create an HDCAM device archive. The material archived to HDCAM devices is compressed significantly. As a consequence of HDCAM compression, the quality of the material in the HDCAM archive may be reduced.

NOTE Archiving to tapes with drop-frame timecode is not supported.

To create an HDCAM archive:

- 1 In the Archive menu, select HDCAM from the Archive Device box.
The options for archiving to an HDCAM device appear.

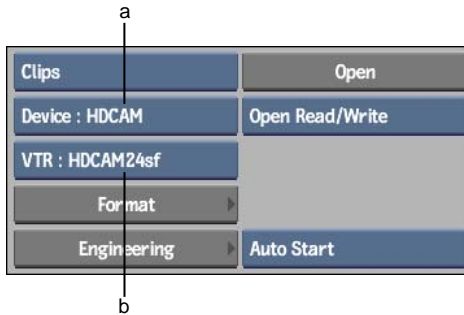

(a) Archive Device box (b) Device Name box

- 2 From the Device Name box, select an HDCAM device.
- 3 Insert a striped tape with continuous non-drop-frame timecode in the VTR.
- 4 Click Engineering and set the Engineering options, then return to the Archive menu. See [Setting Video Input and Output Engineering Menu Controls](#) on page 175.

NOTE The recommended Timecode Source for archiving is LTC. Additionally, if you open an archive in read/write mode, play delay and pre- and post-roll values are verified and set in the auto test run before archiving begins. Therefore, you do not need to set these options.

- 5 If you want to set the start timecode for the archive, select the Manual Start option and enter a timecode.
The start timecode that appears by default is set in the software initialization configuration file.
- 6 If the tape already contains material, determine the start timecode for the archive by playing the tape in the Input Clip menu. See [Controlling a VTR](#) on page 171.
- 7 Click Format.
The Format menu appears.

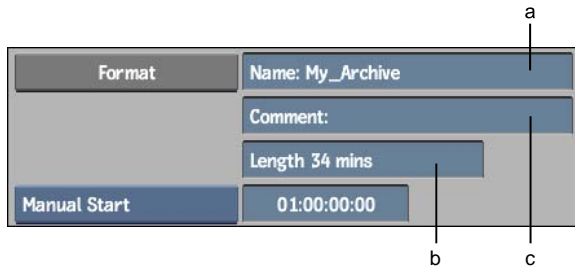

(a) Name field (b) Length field (c) Comment field

- 8 Enter the name for the archive entry and any additional comments in the Name and Comments fields.
- 9 Enter the available space after the Start Time Code in the Length field. Enter the length in minutes.

NOTE If you are creating the archive on a tape that already contains material, make sure you define the length of the archive as the space you want the archive to use, not the total length of the tape.

- 10 Click Format and then Confirm to continue.

The new archive is created on the HDCAM VTR tape and is opened. Save the contents of the current project, clip libraries, Desktop, or reels. See [Saving to an Archive](#) on page 634.

TIP Write down the archive name and creation date on the tape label. This will help you select the appropriate table of contents file if you need to restore your archive.

Creating a Tape Archive

Before archiving to a tape device, make sure:

- The selected device is a fixed, block-size device.
- The tape device is declared in the CLIPMGTDVICE KEYWORD section of the software initialization configuration file.

- A tape is in the tape device. Some devices are unavailable for several minutes after a tape is inserted, so it is best to do this before opening the tape archive module.

To create a tape archive:

- 1 Open the Archive menu.
- 2 From the Archive Device box, select Tape as your archiving device. Options specific to the tape device appear.

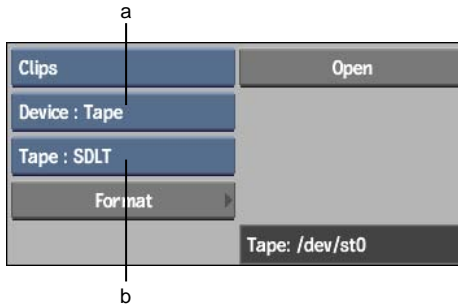

(a) Archive Device box (b) Device Name box

- 3 If necessary, select a tape device from the Device Name box.

NOTE Tape devices are detected automatically when you first enter the Archive menu.

- 4 Click Format. The Format menu appears.

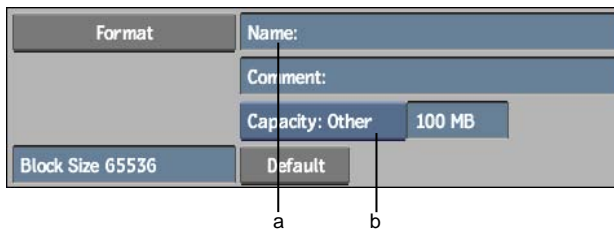

(a) Tape Archive Name field (b) Capacity box

- 5 Enter the name for the archive entry and any additional comments in the Name and Comment fields.
- 6 Select the capacity of the tape from the Capacity box.
The Capacity box displays tape sizes that correspond to tapes generally used by the selected device. If you cannot find the description of the tape, select Capacity: Other and use the adjacent field to enter the capacity of the tape in MB.
- 7 Select Default from the Block Size box to use the default value from the software initialization configuration file. Alternatively, specify an appropriate block size in the adjacent field.
- 8 Click Format and then Confirm to continue.
A new archive is created on the tape, and is opened. Save the current project, clip libraries, Desktops, reels, soft edits, or individual clips. See [Saving to an Archive](#) on page 634.

NOTE Write down the archive name and creation date on the tape label. This will help you to select the appropriate OTOC if you need to restore the archive.

Creating a File Archive

You can create a file archive on any supported filesystem. When you format the archive, Flame determines the available space and creates a table of contents file where this information is recorded. When you reformat an archive, you lose all previously archived entries within it. The archive itself is in a separate file.

NOTE The table of contents and archive files are both given the name you specify when you create the file, but the archive file has the extension `.seg`.

To create a file archive:

- 1 In the Archive menu, select File from the Archive Device box.
By default, the File Path field shows the path of the archive file declared using the ClipMgtDevice File token in the software initialization configuration file.

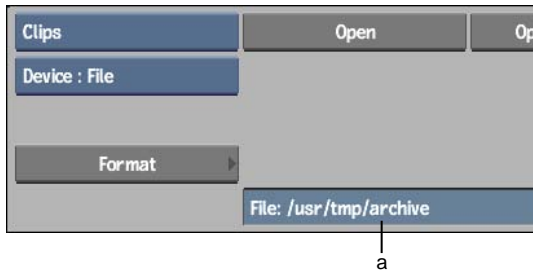

(a) File Path field

- 2 To use the default archive file “archive” in the */usr/tmp* directory, go to step 4. Make sure there is no previously archived material in it before formatting. To create an archive file or select an existing one, go to step 3.
- 3 To change the archive file path, click the File Path field. The file browser appears. Change the directory, and then either:
 - Use the keyboard to enter a name for a new archive file and click Enter.
 - Select an existing archive file.

The Archive menu appears and the name and path of the new or selected archive file appears in the File Path field.

- 4 Click Format.
The Format menu appears.

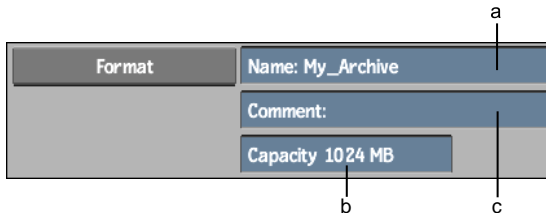

(a) Name field (b) Capacity field (c) Comment field

- 5 Use the Name and Comment fields to enter a name for the archive entry and any additional comments. (Each archive file contains one archive entry within which all other archived entries are saved.)

- 6 Set the capacity of the file archive by entering a value in the Capacity field.

WARNING If you selected an existing archive, any material within it will be deleted when you reformat it in the following step.

- 7 Click Format.

The procedure for creating an archive on external USB and FireWire (IEEE 1394) storage devices is similar to creating a file archive. Before saving files to an archive, browse to the USB or FireWire device filesystem mount point.

Archiving Soft-Imported Clips

There are two ways to archive soft-imported clips:

- **Stone mode:** the media is automatically written to the archive and is no longer soft-imported. This ensures that material will not be overwritten accidentally in the shared storage when you restore the media. When you restore the media, the clips will reside on the local framestore (stonefs) as stonefs frames. To make these clips accessible from the shared storage again, you must publish them.
- **Linked mode:** Only the path to the media is archived. You can later restore the media in the original form as soft-imported frames, provided the media resides at the original paths saved with the archive. If the source clip is not found at restore time, it is displayed as a checkerboard pattern image.

Archiving files using the linked option significantly reduces the amount of space required for your archived clips. It also alleviates bandwidth when archiving to a VTR. Using Linked mode, you can archive both video and audio files. An archived soft-imported clip has an attached soft-import icon corresponding to the file extension.

To archive a soft-imported clip:

- 1 From a clip library, select a soft-imported clip to be archived.

TIP You can use the Search feature to easily locate all the soft-imported clips in your library. See [Searching in an Archive](#) on page 647.

- 2 Create an archive or open an existing archive.



(a) Backup Set box (b) Archiving Mode box

- 3 If necessary, click Size Estimate to determine the size of material to be archived.
- 4 From the Archiving Mode box, select the archiving mode.

Select:	To:
Stone	Write clip to the framestore and archive the content of the media file.
Linked	Archive only the path to the media file.

- 5 From the Backup Set box, select the backup set.

Select:	To:
Compact	Maintain a highly organized archive and save space on the device.
Normal	Archive without using a backup set. Entries are archived directly to the table of contents. Source clips remain in play order on tape.

- 6 Click Save.

Archiving to Multiple Tapes

If the items you select for archiving exceed the capacity of the archiving device (such as a VTR tape, data tape, or a filesystem), you can split the archive across multiple tapes, disks, or files. The splitting of archives is seamless and virtually transparent to the archiving process.

The procedure for creating a multiple tape archive (an archive that is too large for a single tape) is almost the same as for creating an archive on a single tape. If the entries selected for archiving exceed the capacity of the tape, a message

appears indicating that the archive requires multiple tapes. The archiving process begins for the first tape. When the first tape is full, you are prompted to insert a second tape. Insert and format this tape and continue with the archiving. This process continues for as many tapes as are required.

For instructions on how to open a multiple tape archive, see [Opening Multiple Tape Archives](#) on page 633.

Opening an Archive

Once you create an archive, you can add entries to it at any time. For example, you can save entries to an archive after you create it, close it, and open the same archive later to add new entries.

Flame creates an HTML/XML and ASCII table of contents for any archive that you open, including archives created in older versions of the application. To open an archive, use either the table of contents on the medium or the OTOC. Opening an archive with the OTOC is faster because the information is read from the hard drive of the computer rather than from the tape. You load entries from an archive using the OTOC. With VTR archives, you can also save and delete entries.

When you open a VTR archive in read/write mode, Flame performs an auto-test. The auto-test involves checking whether it can write, read, and verify the integrity of the archived material. This auto-test also scans binary and play/record delay information to verify the quality and accuracy of the video signal.

To open a VTR archive:

- 1 In the Archive menu, select VTR from the Archive Device box.
- 2 Select the VTR device.
- 3 Insert the archive tape in the VTR.
- 4 Select the start timecode by doing one of the following:
 - Select Autostart if you selected this option when you created the archive (the archive rewinds the tape to find the start timecode).
 - Select Manual Start and enter the appropriate timecode if you selected this option when you created the archive.

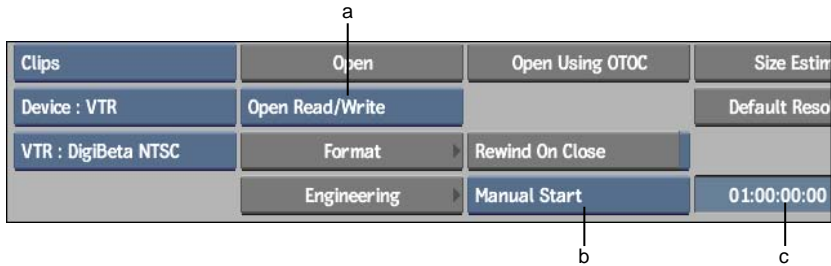

(a) Open Mode box (b) Auto/Manual Start button (c) Time Code field

5 Do one of the following:

- To use the table of contents on the tape, click Open. Select Open Read/Write or Open Read Only from the Open Mode box.

NOTE When you try to open a VTR archive in read/write mode, Flame automatically checks for machine errors (for example, dirty heads). If any problem is detected, the archive does not open. If the tape is write-protected, the archive opens in read-only mode.

- To use the OTOC, click the Open Using OTOC button and select the OTOC in the file browser. You are given the option to read slates from the tape. Answer 'Y' if you wish to see clip proxies.

To open a tape archive:

- 1 Make sure the tape is in the device.
- 2 In the Archive menu, select Tape from the Archive Device box.
- 3 Select the tape device.
- 4 Insert the archive tape in the tape device.
- 5 Do one of the following:
 - To use the table of contents on the tape, click Open.
 - To use the OTOC, click the Open Using OTOC button and select the online table of contents in the file browser. The OTOC does not contain slates, so archive proxies show up as black.

To open a file archive:

- 1 In the Archive menu, select File from the Archive Device box.
- 2 Select the file archive.
- 3 Do one of the following:
 - To use the table of contents in the archive, click Open.
 - To use the OTOC, click the Open Using OTOC button and select the OTOC in the file browser.

NOTE Use the OTOC if the archive table of contents is corrupted or if you want to use a shortcut. See [Recovering an Archive](#) on page 653.

Opening Multiple Tape Archives

When you are creating large archives, you may want to use multiple tapes to store one archive. By splitting the contents of one archive onto separate tapes, you can keep similar types of material together in the same archive.

You can open material on any tape in a multiple tape archive but you will always need the last tape in the multiple tape archive sequence. The last tape contains necessary header information for locating the material you want to restore.

TIP Keep tapes organized and labeled so that you can easily keep track of all the tapes in the same archive.

To open material from a multiple tape device or VTR archive:

- 1 Insert the last tape in the tape device or VTR.
- 2 Click Open.

Flame reads the header information to ensure that the tape is actually the last tape in the sequence. If the incorrect tape is placed in the tape device or VTR, a corresponding error message appears.
- 3 Follow the instruction and then click Continue to proceed.

TIP Click Abort Loading at any time during this procedure to abort the restore procedure.

- 4 Select the backup set that you want to open.
- 5 If the material that you want to open is not on the last tape in the sequence, you are prompted to place the correct tape in the tape device or VTR.
- 6 Place the correct tape in the VTR or tape device and click Continue.
- 7 Click Close when you have finished restoring from the multiple tape sequence.

Saving to an Archive

To save clips to an archive, you must open the archive using the table of contents on the medium. You can save entries from a clip library or from the desktop. For VTR archives, you can also save clips using the OTOC. You can save material to multiple files, device tapes, or VTR tapes.

Archiving Entries

Autodesk recommends archiving directly from a clip library. It allows you to organize your library entries in a clip library in advance. You can also archive from the desktop, but this method gives you less control over the organization of your entries before they are archived.

You can archive entries from any local or shared clip library.

When you save from a clip library, there are two methods for organizing the entries: Normal and Compact. Both methods perform some optimization to save space in the archive. The Compact method creates a backup set, which acts like a container that holds the archived material. It appears in the archive as an entry called Backup Set, and all selected entries are within it. Each time you use Compact, a new backup set is created. When entries are archived using the Normal option, the entries appear directly in the archive.

Normal Archives

With Normal archives, if a frame appears more than once in a source clip, the frame is archived only once. This saves space on the archive and is most noticeable if your clips contain many still shots.

NOTE If the same frame appears in two source clips, the frame will be archived twice.

In a Normal archive, each source clip is archived individually, making restoring individual clips easier and faster and ensuring that frames are output to tape in play order. This makes clips viewable on a VTR archive.

Compact Archives

Compact archives optimize archiving. If a frame appears more than once in *any clip* being archived, the frame is archived only once. No image data for duplicate frames is archived. This saves a significant amount of space on the archive if your clips contain a lot of duplicate frames.

When you create a Compact archive, the archived material is stored in a backup set. You can expand the backup set in the archive library to view and select the clips. You can restore selected clips from a Compact backup set without having to restore the entire archive.

Compact archives are the recommended archive type for Autodesk Smoke and Backdraft Conform projects since they are usually archived as a whole.

NOTE When you open an archive, all entries appear exactly as they did when you selected them, even if entire clips were composed of duplicate frames and not archived. The optimization occurs on the tape, and references to all original clips are kept so that the clips can be restored.

To archive entries from a clip library:

- 1 Open the archive. See [Opening an Archive](#) on page 631.
- 2 Enable Include Audio if you want audio data to be archived with the clips.

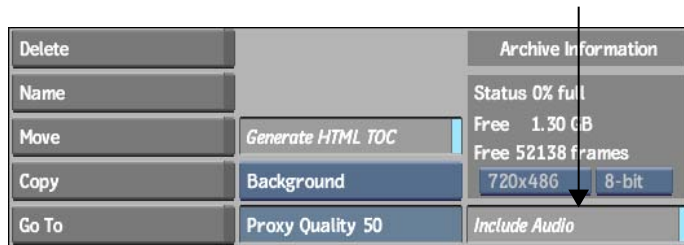

NOTE If you disable the Include Audio button when archiving, the audio track information and audio data will be lost when you restore the clips.

- 3 The Archive Information displays the percentage of space used on the medium and how much space is available for archiving, in both megabytes and frames.

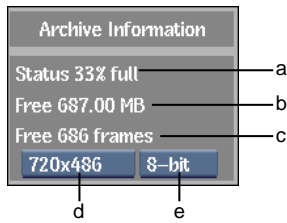

(a) Percentage of space used (b) Available space in MB (c) Available space in frames (d) Resolution box (e) Bit Depth box

- If needed, change the resolution, bit depth, or both to see how many frames of the specified dimensions can be archived.

NOTE When archiving to a VTR, you can only archive clips of the resolution supported by the VTR, therefore the Resolution box is greyed out and displays the resolution of the currently selected VTR.

- Click Save From Library.
The current clip library appears.

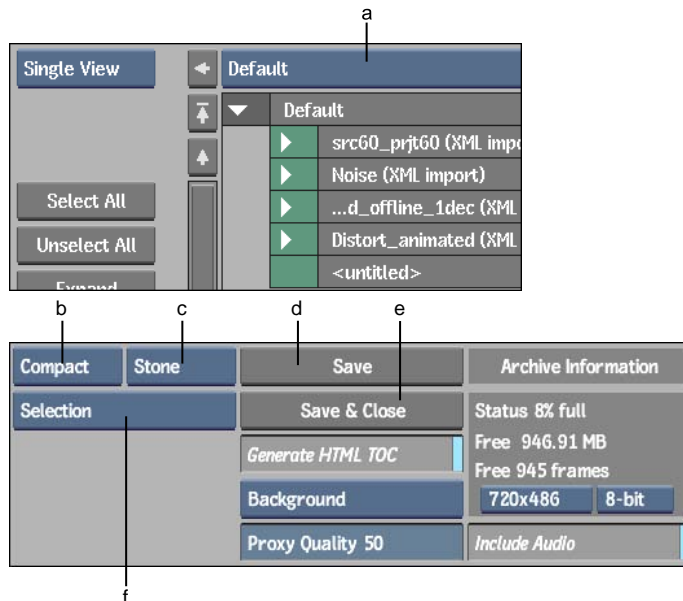

(a) Clip Library box (b) Backup Set box (c) Archiving Mode box (d) Save button (e) Save & Close button (f) Entry Type box

6 From the Clip Library box, select the required clip library.

7 From the Backup Set box, select the backup set.

Select:	To:
Compact	Maintain a highly organized archive and save space on the device.
Normal	Archive without using a backup set. Entries are archived directly to the table of contents. Source clips remain in play order on tape.

8 If archiving soft-imported clips, select the archiving mode from the Archiving Mode box.

Select:	To:
Stone	Write the clip to the framestore and archive the content of the media file.
Linked	Archive only the path to the media file.

9 From the Entry Type box, select the entries that you want to archive.

Select:	To archive:
Project + Shared	Project Desktop, setup directory, clip libraries, shared clip libraries, and metadata
Project	Project Desktop, setup directory, clip libraries, and metadata
Project Libraries	Current project clip libraries
Project Libraries + Shared	Current project clip libraries and imported (shared) clip libraries
Project Libraries	Current project clip libraries
Selection	Selected entries

10 Do one of the following:

- Click Save if you want to add additional items to the archive. You are returned to the desktop. Follow steps 5 to 10. When finished, click Close.
- Click Save & Close to archive selected entries and close the archive immediately.

Additional Optimization

Both Normal and Compact archives add a second level of optimization by saving only one copy of clips. If a clip appears more than once in the archive, the clip is archived only once. Also, if you append to an archive and a clip already exists in the archive, the clip is not added to the archive—that is, no image data for the duplicate clip is archived.

Archiving Entries from the Desktop

You can save a project, clip library, desktop, reel, soft clip, or clip to the selected archive.

To save entries from the desktop:

- 1 Open the archive. See [Opening an Archive](#) on page 631.
- 2 Enable Include Audio if you want audio data to be archived with the clips.

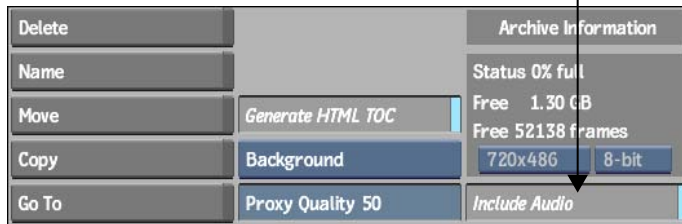

NOTE If you disable the Include Audio button when archiving, the audio track information and the audio data will be lost when you restore the clips.

- 3 The Archive Information displays the percentage of space used on the medium and how much space is available for archiving, in both MB and frames.

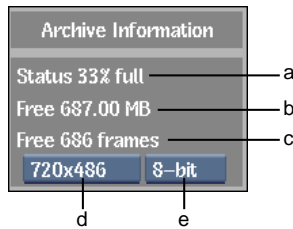

(a) Percentage used (b) Available space in MB (c) Available space in frames
(d) Resolution box (e) Frame Depth box

If needed, change the resolution and/or frame depth to see how many frames of the specified dimensions can be archived.

NOTE When archiving to a VTR, you can only archive clips of the resolution supported by the VTR, therefore the Resolution box is greyed out and displays the resolution of the currently selected VTR. Also, you can only archive 24-bit clips to a VTR.

- 4 Click Save in the Archive menu.
- 5 Select an option from the Entry Type box that appears.



Select:	To:
Project + Import	Save the Desktop, all clip libraries, and imported media to the archive.
Project	Save the Desktop and all clip libraries to the archive.
Clip Library	Save the current clip library to the archive. Before selecting this entry, make sure that you select the appropriate clip library using the Clip Library box in the Archive menu.
Desktop	Save the Desktop to the archive.

Select:	To:
Reel	Save a work reel to the archive.
Clip	Save a clip or soft edit to the archive.

- 6 Select the clip or reel to be saved, or click Save:
 - If you are saving a project, clip library, or desktop, a Save button automatically appears. Click Save to save the project, clip library, or desktop. Click elsewhere to cancel.
 - If you are saving a reel, select a clip on the reel that you want to save.
 - If you are saving a clip, select the clip that you want to save.

The keyboard appears.

- 7 If the entry that you are saving already has a name, the name appears in the Keyboard field. Otherwise, use the keyboard to enter a name for the entry.
- 8 Press Enter.

The project, clip library, desktop, reel, or clip is archived under the specified name. If necessary, the name of the clip, reel, or desktop is changed on the desktop.

NOTE Flame checks for space availability on the selected medium before beginning the archive. If there is insufficient space, an error message appears and the process is terminated.

A time estimate appears once Flame starts saving to the archive (for tape and VTR archives, the time estimate appears after the tape is rewound).

- 9 Repeat the procedure from step 4 for any other entries you want to save to the archive.
- 10 When you are finished, close the archive. See [Closing an Archive](#) on page 640.

Closing an Archive

When an archive is open, the Close button appears in the Archive menu. Click this button to update the table of contents, close the device, and eject the tape from the drive.

If you are archiving to a VTR, you can rewind to the beginning of the tape automatically when you exit the Archive menu. To do this, enable the Rewind On Close button.

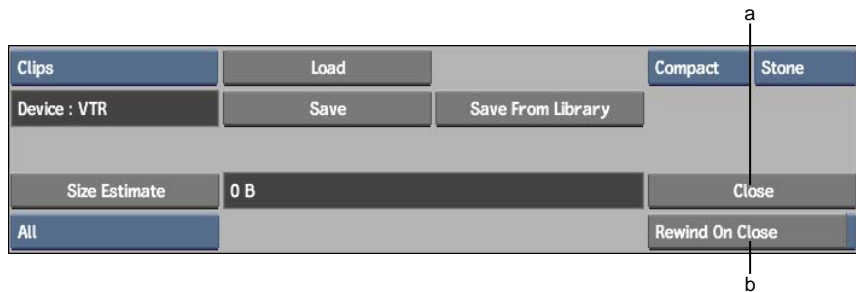

(a) Close button (b) Rewind On Close button

NOTE If you attempt to exit the Archive menu, you are prompted to close the device. Click Confirm to close the device, or click elsewhere to cancel.

Managing Archives

In most cases you maintain an archive over the course of a project, appending clips, deleting clips, and restoring archived clips. Typically, the following procedures are performed:

- [Browsing an Archive](#) on page 642
- [Searching in an Archive](#) on page 647
- [Appending Entries to an Existing Archive](#) on page 648
- [Deleting Entries from an Archive](#) on page 649
- [Setting Preferences When Restoring Archives from Previous Versions](#) on page 650
- [Recovering an Archive](#) on page 653
- [Deleting Tables of Contents](#) on page 647

Browsing an Archive

Each archive includes a header file, which is located at the beginning of the archive and contains the metadata necessary for properly restoring the archive. When you create an archive, a table of contents is also created on the archiving device in case the header information becomes corrupted.

You can view the table of contents with the ASCII or HTML TOC:

- To view the contents of your archive, open the ASCII TOC file in a text editor. See [Using an ASCII TOC to View an Archive](#) on page 643.
- To view proxies displaying the contents of the archive, open the HTML TOC in a Web browser. See [Using an HTML TOC to View an Archive](#) on page 643.

Online Tables of Contents (OTOCs)

The table of contents lists the contents of the archive, as well as information such as the order in which clips are assembled on the archive, clip IDs, transitions, and timecodes. When you restore an archive with the table of contents, Flame uses this information to restore the material.

A copy of the table of contents is saved in the filesystem. This copy is referred to as the Online Table of Contents (OTOC). You can open an archive in read-only mode using the OTOC. In read-only mode, you can load but not save or delete entries from the archive. With VTR archives, you can open an archive in read-write mode using the OTOC, and save and delete entries from the archive.

The OTOC is useful for:

- Recovering material in an archive when the table of contents on the medium is corrupted. See [Recovering an Archive](#) on page 653.
- Opening an archive quickly.

When an OTOC is created, Flame creates an ASCII text copy of it (ATOC) as well as an HTML and XML copy. Use the ASCII and HTML copies to view the contents of an archive without opening it. For example, use them to view the contents of a VTR archive without connecting to the VTR. You can also use the XML TOC to easily populate a database with information about your archives.

The OTOC, ATOC, HTML, and XML TOCs are saved to the path specified in the ArchiveLibrary token in the software initialization configuration file. If the ArchiveLibrary token is disabled, they are saved to `/usr/discreet/archive`. You can also define the ArchiveLibrary token in the project configuration file by adding the line:

```
ArchiveLibrary <directory>
```

where `<directory>` is replaced by the location for storing your archives.

The OTOC is updated each time you close the archive.

See [Using an ASCII TOC to View an Archive](#) on page 643 and [Using an HTML TOC to View an Archive](#) on page 643.

Using an ASCII TOC to View an Archive

Open the ASCII version of the table of contents using *nedit* to view the contents of an archive without opening it. ASCII TOC filenames have the following format:

```
<archive name>_<creation date>.atoc
```

By default, the files are stored in the `/archive` directory for your project. The contents of the ASCII files are labelled as follows.

Code	Meaning
P	Project
L	Clip library
D	Desktop
R	Reel
C	Clip/soft-edit
E	Source clip

Using an HTML TOC to View an Archive

To view the contents of an archive without opening it, open the HTML version of the table of contents using a Web browser.

NOTE You can use a Web browser other than the default specified in the DEFAULT WEB BROWSER section of the software initialization configuration file. The browser name must be in the environment path to avoid errors. If you cannot open an OTOC, specify Firefox as the default Web browser in the software initialization configuration file.

The HTML TOC is conveniently organized, displaying JPEG proxies for the first and last frame of each clip in the archive.

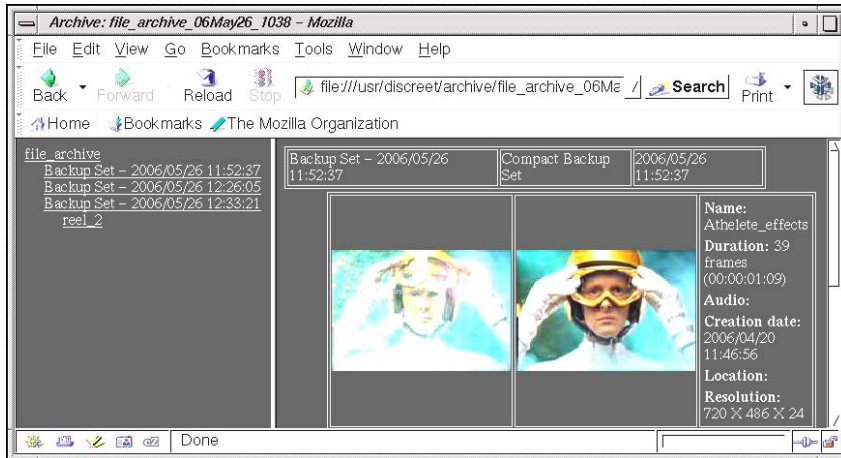
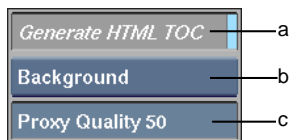

Image courtesy of Das Werk

To create an HTML TOC:

- 1 Open the archive. See [Opening an Archive](#) on page 631.



(a) Generate HTML TOC button (b) Proxy Generation box (c) Proxy Quality field

- 2 Enable Generate HTML TOC.

- 3 Determine how the JPEG proxies are generated by selecting an option from the Proxy Generation box.

Select:	To:
Background	Generate the JPEG proxies while the archive is being created.
Foreground	Generate the JPEG proxies after the archive has been created.

- 4 Set the JPEG quality setting using the Proxy Quality field.
An HTML TOC, along with JPEG proxies, is updated each time you close the archive.

NOTE The HTML TOC is generated from the XML TOC based on the HTML templates installed in `/usr/discreet/<product home>/templates`.

To view an HTML TOC:

- 1 Open the Archive menu.
- 2 Click View HTML TOC.

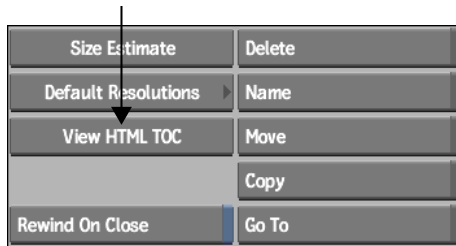

The file browser appears with the list of all HTML TOCs available.

- 3 From the list, select an HTML TOC to open and click Confirm.
A default Web browser opens and the available TOCs are listed under the "Table of Contents" heading.
- 4 Click the table of contents that you want to open.

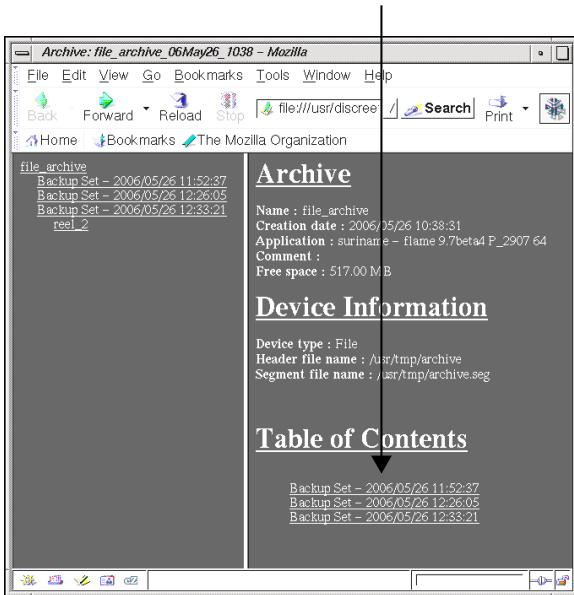

The contents of the archive appear.

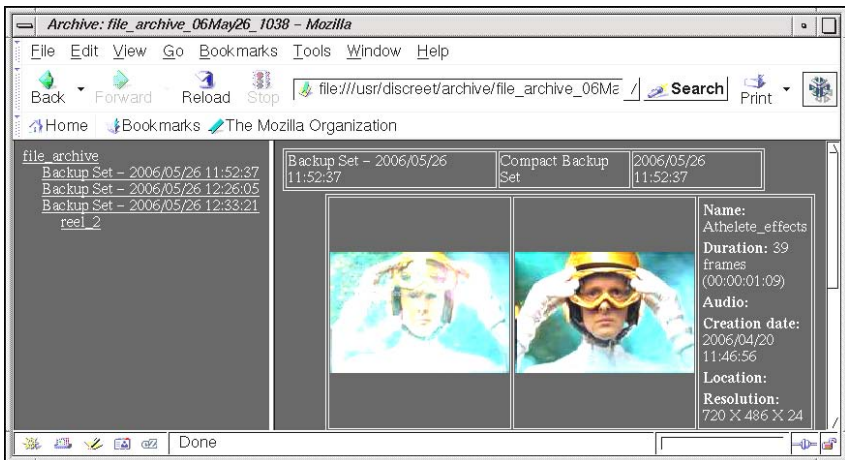

Image courtesy of Das Werk

Deleting Tables of Contents

To prevent the loss of important data, Flame never overwrites the previously created tables of contents. If the archive becomes obsolete or if you are sure that older versions of an archive OTOCs are obsolete, you can delete tables of contents. The following name formats are used for the tables of contents.

Type	Format
Online (two files)	<code><archive name>_<creation date>.otoc</code> <code><archive name>_<creation date>.otocx</code>
ASCII	<code><archive name>_<creation date>.atoc</code>
XML	<code><archive name>_<creation_date>.xml</code>
HTML (two or more files)	<code><archive name>_<creation_date>.html</code> <code><archive name>_<creation_date>/*</code>

where `<archive name>` is the name that you type in the Name field when you create the archive.

You can use the **rm** command to delete a table of contents.

To delete tables of contents:

- 1 Make a backup copy of the tables of contents you want to delete, or use your usual method for backing up files.
- 2 Use the **cd** command to go to the directory where the tables of contents are stored. By default, it is the `/usr/discreet/archive` directory.
- 3 Enter the command **rm** `< name of archive >`.

Searching in an Archive

You can use the Search menu to perform clip searches in an archive.

To open the archive Search menu:

- 1 Open the archive. See [Opening an Archive](#) on page 631.
- 2 Click Save From Library.
- 3 Click Search to display the Search menu.

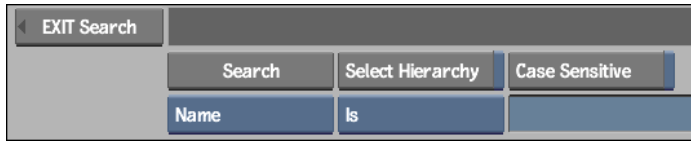

The search tool can be useful, for example, when you need to identify clips of a certain resolution in an archive containing clips of multiple resolutions. You can do this by selecting the corresponding criterion (Resolution) and setting the required arguments in the related fields (Specific Width, Specific High, and Aspect Ratio) as shown in the following illustration.

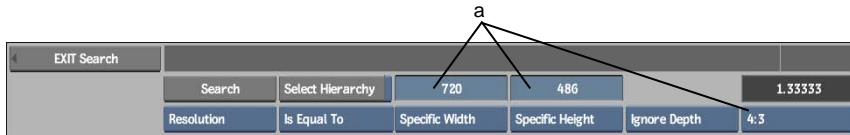

(a) Search criteria specified in the Specific Width/Height fields and the Aspect Ratio box

The search controls and available options are similar to those found in a clip library. See [Searching for Clips](#) on page 582.

Appending Entries to an Existing Archive

You can add new material to an existing archive as long as there is space on the archiving medium. When opening an archive to add entries, use the table of contents on the archive. For VTR archives, use the OTOC to add entries.

NOTE If you want to open an archive using the OTOC on a machine other than the one on which it was created, copy the OTOC to the new machine.

To append entries to an existing archive:

- 1 Open the archive. See [Opening an Archive](#) on page 631.

The Archive menu appears.

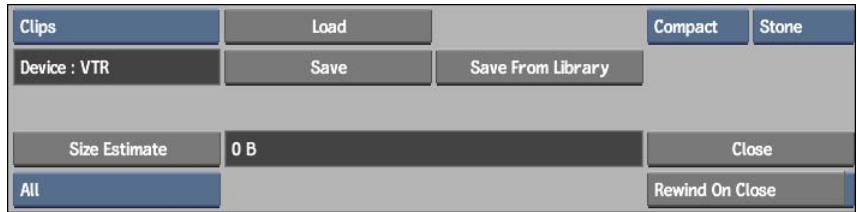

2 Do one of the following.

Click:	To:
Save	Select clips to archive from the Desktop.
Save from Library	Select clips to archive from the clip library.

3 Select the backup set from the Backup Set box.

4 Select the entries you want to add to the archive.

5 When archiving from the clip library, after selecting the clips, do one of the following.

Click:	To:
Save	Save the selected clips to the archive.
Save & Close	Save the selected clips to the archive, and then close the archive.

NOTE You can exit from the Save Clip from Library menu to continue adding clips from the desktop to the archive.

6 If you have not already done so, close the archive.

Deleting Entries from an Archive

To ensure data integrity and prevent archive corruption, deleting entries from an archive is not allowed.

Archive Compatibility

Archives created using any current Autodesk Visual Effects and Finishing application are fully compatible with all other current Autodesk Visual Effects

and Finishing applications. These archives cannot be restored to earlier versions of Visual Effects and Finishing applications.

Archives created using earlier versions of Visual Effects and Finishing applications are read-only when restored to 2009 versions. That is, you can restore an older archive to a 2009 application, but you cannot append material to the archive (you must create a new archive to do this).

There are some differences in how 2009 Visual Effects and Finishing applications restore archives. The following table summarizes these differences.

Archive Type	Behaviour when restoring to Inferno, Flame, and Flint	Behaviour when restoring to Smoke and Backdraft Conform
Selection (Part of a Project)	Archives can be restored to the Desktop or to the clip library.	Archives can only be restored to the clip library.
Whole Project	The Desktop is restored as a reel in a new library.	The EditDesk is restored as a reel in a new library.

12-bit clips cannot be archived on VTRs. Tape devices support archival of all bit depths.

Setting Preferences When Restoring Archives from Previous Versions

In versions earlier than 8.5, archives did not include all the metadata information that version 2009 needs to restore archives with the correct scan mode and aspect ratio. The Default Resolutions menu makes it possible to assign the scan mode and aspect ratio preferences to older archives. The information you need to assign depends on the software version in which the archive was created. Assign the information using the Default Resolutions menu. Use the following table to determine which information you need to assign to your old archive.

Archived clips prior to:	Information you must assign:
Smoke 6.0, Fire® 6.0, Inferno 5.5, Flame 8.5, Flint 8.5, and Backdraft 5.5	Scan mode
Smoke 5.2, Fire 5.2, Inferno 5.0, Flame 8.0, Flint 8.0, and Backdraft 5.0	Scan mode and aspect ratio

The parameters listed in the Default Resolutions menu act as default values for all listed resolutions. For example, if you want to change the default values for PAL clips, you must change the values for the PAL entry, which is the entry that has a width value of 720 and a height value of 576. If you are working with a PAL archive created in an earlier version, the aspect ratio would have automatically been set to 1.3333, but you may want to restore all your PAL archives with 16:9 aspect ratio. You can change this setting by changing the aspect ratio to 16:9 for the PAL entry.

NOTE You should only restore an old clip at one resolution. If you restore versions of the same clip at different resolutions, you may encounter problems with the clip.

To add an archiving preference:

- 1 In the Archive menu, click Default Resolutions.

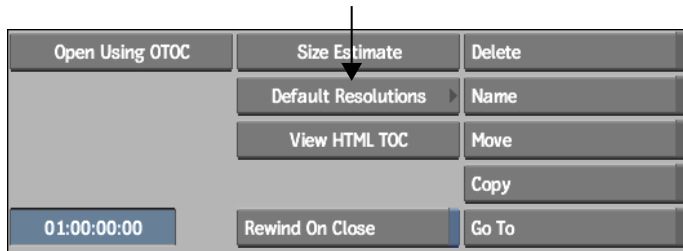

The Default Resolutions list and menu are displayed.

Width	Height	Aspect Ratio	Scan Mode	Frame Rate
640	480	1.333333	P	Undefined fps
720	486	1.333330	F1	29.97 fps
720	576	1.333333	F1	25 fps
1280	720	1.777778	P	59.94 fps
1828	1332	1.372372	P	24 fps

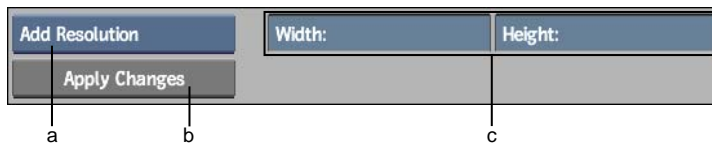

(a) Add Resolution box (b) Apply Changes button (c) Width and Height fields



(d) Aspect Ratio field (e) Aspect Ratio box (f) Scan Mode box (g) Framerate box

- 2 Enter values in the Width and Height fields.
- 3 Select a default aspect ratio value from the Aspect Ratio box or enter a custom value in the Aspect Ratio field. Specifying a unique aspect ratio causes the Aspect Ratio box to show Custom automatically.
- 4 From the Scan Mode box, select Progressive, Field 1, or Field 2 to determine how the lines of the contents of the archive are scanned.
- 5 From the Framerate box, select a framerate.
- 6 Click Add Resolution.
- 7 Click Apply Changes.
The new archive preference is added to the list.

To open an archive using a selected archive preference:

- 1 In the Archive menu, click Default Resolutions to display the Default Resolutions menu.
- 2 Add new preferences to correspond to a specific clip resolution contained in the archive that you plan to open.
- 3 Open the archive created in an earlier version.

TIP It is recommended that you open the archive with Open Read Only selected since you are opening an archive created in an earlier version. When you open in Read-Only mode, an auto test is not executed.

- 4 In the Archive menu, click Load.
- 5 Select the clips to be loaded from the archive.
- 6 If you want to see the preference that is applied to the clip, press **Alt** as you drag over the clip.
The applied preference appears in the message bar as you drag over the clip.
- 7 Continue restoring the archive.

To edit an existing preference:

- 1 In the Archive menu, click Default Resolutions.
- 2 In the Default Resolutions list, select the entry you want to modify.
- 3 Modify the values and press **Enter** after each change.
- 4 Select Edit Resolution.
- 5 Click Apply Changes.
The changes are applied to the selected preferences.

To delete an existing preference:

- 1 In the Archive menu, click Default Resolutions.
- 2 In the Default Resolutions list, select the entry you want to delete.
- 3 Select Remove Resolution.
- 4 Click Apply Changes.
The selected resolution is removed.

Recovering an Archive

If the table of contents of an archive on tape is corrupted, Flame may not be able to read it. If this happens, open the archive using the OTOC.

Once you open the archive, you can restore the entire contents of the archive and save it to a new tape. Do this, for example, if the tape has been damaged.

For VTR archives, you can also overwrite the corrupted table of contents by saving a single frame to the archive. If the table of contents is successfully overwritten, you can open the archive using the Open button.

To restore the archive:

- 1 Open the archive. See [Opening an Archive](#) on page 631.
If the table of contents is corrupted, the following message appears:

```
CLIP MGT: Warning! Cannot read archive header.  
Select online TOC?
```
- 2 Click Confirm to open the OTOC.
The file browser appears.

- 3 Select the OTOC for the archive you are trying to open and click Confirm.
- 4 If the archive is on a VTR, a prompt asks if you wish to retrieve the slates (proxies). Press Y to see proxies in the archive or N to have no proxy images.

After a moment, the archive appears.

NOTE When you open an archive with the OTOC, proxies only appear if the archive is on a VTR, and you answered Yes to the prompt. For all other types of archives, proxies appear as black images.

- 5 Select the entire contents of the archive. Make sure you have sufficient space on the framestore for the contents of the archive.
- 6 Click Restore.
- 7 When the restore is complete, click Close.
The restored clips appear in the selected clip library.
- 8 Re-archive the material onto a new tape as described in [Archiving Entries](#) on page 634.

To overwrite a corrupted table of contents (VTR only):

- 1 In the Archive menu, click Open. See [Opening an Archive](#) on page 631.

If the table of contents is corrupted, the following message appears:

```
CLIP MGT: Warning! Cannot read archive header.  
Select online TOC?
```

- 2 Click Confirm to open the OTOC.
The file browser appears.
- 3 Select the OTOC for the archive you are trying to open and click Confirm.
A prompt asks if you wish to retrieve the slates (proxies).
- 4 Click Y to see proxies in the archive or N to have no proxy images.
After a moment, the archive appears.

NOTE When you open an archive using the OTOC, proxies appear only in a VTR archive, and if you selected Yes in the previous prompt. For all other types of archives, proxies appear as black images.

- 5 From the Library Type box, select a clip library.

- 6 Select a reel entry by **Alt**-clicking the reel and then click Archive.

NOTE When you select a reel, no media is appended to the archive but the header is still forced to update.

- 7 Click Close to close the archive.
- 8 Click Open to open the archive.

Archiving and Restoring Setups

When you archive a project setup, you create a file archive of all setup, resource, and media files in your home directory of your project. If your project is primarily one resolution with a few custom resolution plates, consider exporting them to the images directory. Archive the standard-resolution material to VTR. Of course, you cannot export files and conserve potentially valuable metadata.

You can archive and restore setups previously saved in any Flame module. When you save setups as you work in different modules, they are saved by default in the current project. When you archive setups, they are archived in the current project. Before archiving setups, make sure you have:

- Saved your setups. See [Saving Setups and Preferences](#) on page 799.
- Defined your project. See [Managing Projects and Users](#) on page 521.
- Achieved the desired effect(in the modules.

NOTE You can archive setups to a file, to tape devices, or an external USB/FireWire Drive.

Archive setups using the Archive Setups menu.

To access the Archive Setups menu:

- 1 Open an existing archive or create a new archive to display the Archive menu.
- 2 In the Archive Type box, select Setups.
The Archive Setups menu appears.

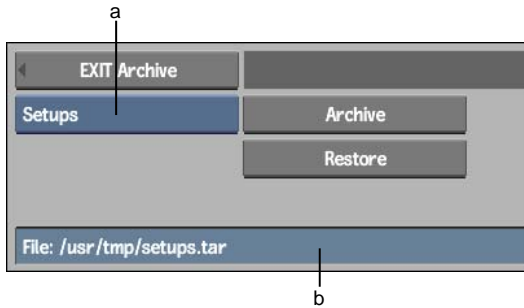

(a) Archive Type box (b) Setup Archive Name field

To archive project setups:

- 1 The Setup Archive Name field contains the default path for the archive file, as specified in the `SETUPARCHIVETAPE` `KEYWORD` section of the software initialization configuration file. If you want to change the path, click the Setup Archive Name field; otherwise, go to step 4.
The file browser and on-screen keyboard appear.

NOTE Only one device can be specified at a time.

- 2 If needed, select another directory using the file browser.
- 3 Type a new filename using the on-screen keyboard, and click Enter.
The file browser closes and the Archive Setups menu reappears. The new path appears in the Setup Archive Name field.
- 4 Click Archive, then click Confirm.
An archive file for your current project setups is created. It includes all setups you saved in your modules.
- 5 Click EXIT Archive.

To restore project setups:

- 1 Display the Archive Setups menu.
- 2 The Setup Archive Name field displays the last saved archive. If you want to select a different archive, click the Setup Archive Name field; otherwise, go to step 4.
The file browser appears.

- 3 If needed, select another directory using the file browser.
- 4 Select the archive you want to restore by clicking on it.
The file browser closes and the Archive Setups menu reappears.
- 5 Click Restore, then click Confirm.
The archive file containing your project setups is restored into the current project. That is, all the setups you saved in your modules are loaded into the appropriate modules.

Optimizing Archiving Operations

Optimize archiving operations with the following guidelines.

Organizing Archives

Although the way you organize your archives is a matter of personal preference, the following guidelines may be helpful:

- After you have processed a clip, remove any material that you are no longer using before you create your archive.
- Try to keep your libraries clean at all times. Remove clips that are no longer being used or earlier unused versions of your work.
- Use a consistent and clear naming technique so that you can easily find your material when you want to create or open an archive.
- Consolidate and compact clips before archiving in order to save space. See [Consolidating Clips](#) on page 311 and [Compacting Clips](#) on page 313.

Tips and Troubleshooting

The following tips may help avoid some common archiving problems:

- Do not attempt to archive material captured with Headroom as the Output mode. Such material cannot be archived.
- Check the scan mode of Flame and make it consistent with your VTR and VCP settings. Use the F1 Scan mode in the Engineering menu. You cannot create an archive on a VTR when the Scan Mode option in the Engineering menu is set to F2.

- Ensure that you are using a non-drop-frame timecode tape. You cannot create an archive on a drop-frame timecode tape.
- With an Ampex DCT D1 deck, the VTR cues to the wrong timecode (the next ascending minute) when archiving. To work around this problem, select the Manual Start option and enter the desired timecode.
- Ensure that you have version 3.1.2 (or later) of the DST driver to use the DST tape drive with Flame.

Forcing an Archive To a Single Tape

In some cases, an archive on a single tape may be accidentally tagged as a multi-tape archive. This results in the application prompt to insert a second tape when there is no need for it.

To fix this problem, use the following environment variables to identify archives that are not tagged correctly, and then to force the archive to register as a single tape:

DL_DUMP_ARCHIVE_TOC

DL_ARCH_FORCED_NB_VOLUMES

WARNING Autodesk recommends the following procedures only if you are a specialist. Otherwise, please contact Autodesk Media and Entertainment Customer Support for help at <http://www.autodesk.com/support>.

To identify archives mistakenly tagged as multi-tape:

- 1 In a command shell, type `setenv DL_DUMP_ARCHIVE_TOC`.
- 2 Launch Flame from the shell.
- 3 Open an archive from the Archive menu.
- 4 Examine the feedback in the shell: scroll down past the list of segments and look for “volume=<# of volumes for archive>”.
The number of volumes indicates how many tapes the application registers as being used for the archive. If the number of volumes is more than one and the archive is on a single tape (the line would read “volume=2”) proceed with the following steps.

To force an archive to a specific number of tapes:

- 1 If necessary, quit Flame.
- 2 In command shell, type the following to force the archive to a single tape:

```
setenv DL_ARCH_FORCED_NB_VOLUMES 1
```

- 3 Relaunch Flame from the same shell and proceed to restore the archive from tape.

Mistakenly changing the number of tapes for an archive results in corrupted clips. It can happen, for example, if the archive is spread over two tapes and you force it to one tape. However, the source material on the tape is not corrupted. If you have corrupted clips, try starting another session of Flame without using the *DL_ARCH_FORCED_NB_VOLUMES* environment variable.

Part 6: Pre-processing

Part 6 includes these chapters:

- [Resize](#) on page 663
- [2:3 Pulldown](#) on page 703
- [Video Field Management](#) on page 719
- [Colour Management with LUTs](#) on page 729
- [Adding and Removing Film Grain](#) on page 773



Image courtesy of Fischer Edit

Topics in this chapter:

- [About Resize](#) on page 664
- [Resizing on Import, Export, or in a Clip Library](#) on page 665
- [Resizing in the Resize Module](#) on page 667
- [Resizing in Batch](#) on page 668
- [Soft Resizing a Clip](#) on page 678
- [Changing Views in Resize and in Batch](#) on page 679
- [Resize Settings](#) on page 681
- [Resizing from Source Using the Crop Box](#) on page 685
- [Resizing to Destination Using the Crop Box](#) on page 687
- [Animating Resize Settings](#) on page 688
- [Saving and Loading Resize Setups](#) on page 689
- [Getting Dynamic Feedback in Result View](#) on page 693
- [Processing Clip Handles When Working with Soft Clips](#) on page 694
- [Resetting All Resize Settings to Default Values](#) on page 695
- [Changing the Appearance of the Crop Box](#) on page 696
- [Changing the Padding Colour](#) on page 697
- [Setting Default Image Resolution Characteristics on Import](#) on page 698

About Resize

When working with clips of different resolutions, you will sometimes need to resize clips. Use **Resize** to change the resolution of a clip and its frame bit depth. Typically, you resize clips in these cases:

- If you want to load mixed resolution clips into a module (as front, back, and matte clips), you must use **Resize** to make them the same resolution or the module will not accept the input clip selection.
- If you want to load a front and matte clip that are not the same resolution as Action media, you must use **Resize** to make them the same resolution or Action will not accept the input clip selection. Different Action media can be of different sizes—only the front and matte of each media must be the same size. You can get the best results by keeping the original resolution of all clips in Action and then resizing them using Action's axis transforms.
- If you have a master clip of your project's default resolution, you can resize the master to deliver to other resolutions.

Resize includes a crop box that you use to define the region of the source clip from which the resize sample is taken. Use the crop box to pan and scan 16:9 masters to a 4:3 delivery format.

You can animate the frame size of a clip, provided the result is used as an intermediate process in Batch. For example, you can animate the frame size of a clip and feed the result into Action media. You cannot output a clip that has anything other than a constant frame size from frame to frame.

Accessing Resize and Resize Settings

Flame provides clip resize settings in many locations to suit the mixed resolution workflow needs of your project. You can access resize settings from the following locations:

- The Import Image menu, the Export Image menu, or the Clip Library menu. See [Resizing on Import, Export, or in a Clip Library](#) on page 665.
- The timeline, using a **Resize** soft effect. See [Soft Resizing a Clip](#) on page 678.
- The **Resize** module from the desktop. See [Resizing in the Resize Module](#) on page 667.

- In Batch from clip nodes, the Resize node, the Export node, the Output node, and the Batch FX Output node. See [Resizing in Batch](#) on page 668.
- In Flame, when setting the output resolution. See [Rendering Settings](#) on page 2118.

Resizing on Import, Export, or in a Clip Library

You can resize clips when you load them from a clip library or when you input them from the Import Image menu. In this case, you cannot preview the resized result.

The clip library provides access to clips of all sizes on local and remote framestores. When you resize a clip while loading it from a clip library, you create a new clip. You may want to save the resized result to another clip library.

Although you can resize images on import, it is a good idea to import an image without changing its size. Doing so preserves the source resolution, and this in turn gives you more options to use the image. For example, if you resize an HD image to NTSC on import, you cannot restore the image information lost by the resize process.

However, because file-based images have square pixels, it is recommended that you set resize settings to assign the proper frame aspect ratio on import when importing images that originate from formats that use non-square pixels.

In some cases, for example, with NTSC and PAL images, Flame detects the image frame size (720x486 or 720x576) and from this suggests that you resize the image by using a frame aspect ratio of 1.333 (4:3). If you are working with 1.778 (16:9) NTSC or PAL, you should override this setting.

With other non-square pixel images, such as those originating from anamorphic film formats, you must manually specify the frame ratio that corresponds to the image (for example, 2.35); otherwise, the images are imported assuming square pixels.

To access the resize settings from a clip library:

- 1 In the Main menu, click Library.
- 2 Click Load and then select a destination reel.
- 3 From the clip library, select the clips that you want to load from the clip library.

- To resize the clip while loading it, enable **Resize**.
The **resize settings** are enabled.



- Set the **resize settings**. See [Resize Settings](#) on page 681.
- Click **Load**.

To access the resize settings on import:

- In the **Library** menu, click **Import Image** and select a destination reel.
The **Import Image** menu appears.
- Browse to and select the images that you want to import.

TIP You can select multiple images and image sequences for a single import. However, when you **resize on import**, the same **resize settings** are applied to the entire selection. Make sure your **resize settings** correspond to the selection of images.

- To **resize clips on import**, enable **Resize**.

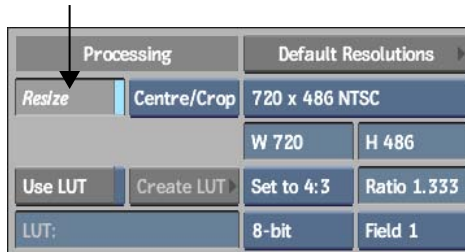

- Set the **resize settings**. See [Resize Settings](#) on page 681.

To access the resize settings on export:

- Open the clip library containing the clip that you want to export.

- 2 Select the clip.

TIP You can select multiple images and image sequences for a single export. However, when you resize on export, the same resize settings are applied to the entire selection. Make sure your resize settings correspond to the selection of images.

- 3 Click Export Image.
- 4 Set the resize settings. See [Resize Settings](#) on page 681.

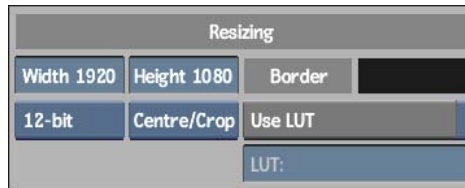

Resizing in the Resize Module

All clips on the desktop can be resized at any time using the Resize module.

To access the Resize module:

- 1 In the Main menu, click Format.
- 2 In the Format menu, click Resize.



- 3 Select the clip that you want to resize.
- 4 Select a destination reel.
The Resize module opens.

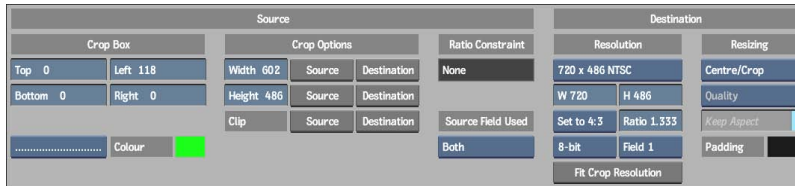

5 Set the resize settings. See:

- [Resizing from Source Using the Crop Box](#) on page 685
- [Resizing to Destination Using the Crop Box](#) on page 687
- [Animating Resize Settings](#) on page 688

Resizing in Batch

Resizing in Batch is advantageous because you only commit the resize on output. You can resize clips in Batch in the following ways:

- From an Import node
- From a clip
- From a Resize node
- From an Output node
- From a Batch FX Output node
- From an Export node

In all cases, using resize settings in Batch provides dynamic feedback as you make changes.

If you are working with a complex process pipeline, track your resize operations relative to other nodes in the process pipeline. If you resize a clip, you may invalidate the inputs of a node further downstream because the input sources are no longer the same size.

NOTE Resize settings in all nodes in the processing pipeline are disabled when you work with proxies. See [Using Proxies in Batch](#) on page 1286.

Resizing from an Import Node

When you import images to the Batch schematic, the Import node includes resize settings. Using these resize settings:

- You define resize settings at the very start of the processing pipeline.
- Unlike using resize settings from the Import Image menu, you have access to the crop box and you can animate resize settings.
- You can lock the resize result to the crop box to animate the frame size.
- You can toggle the resize settings on and off.

To access resize settings from an Import node:

- 1 Drag an Import node to the Batch schematic.
The file browser appears.
- 2 Use the file browser to select the image sequence that you want to import.
- 3 Click Load.



A clip node appears on the Batch schematic.

- 4 Select the clip to view its menu.
- 5 Select Resize.

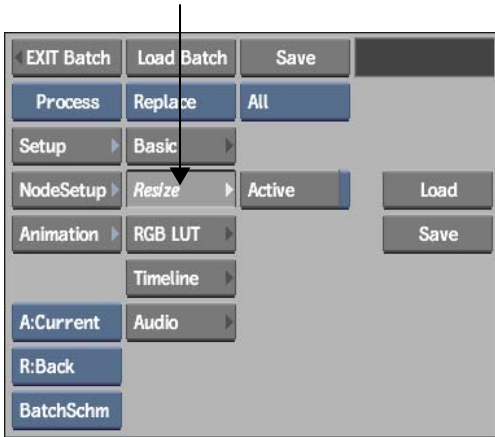

The Resize menu appears.



By default, it is set to resize the clip to the project's default resolution.

6 Enable Active.

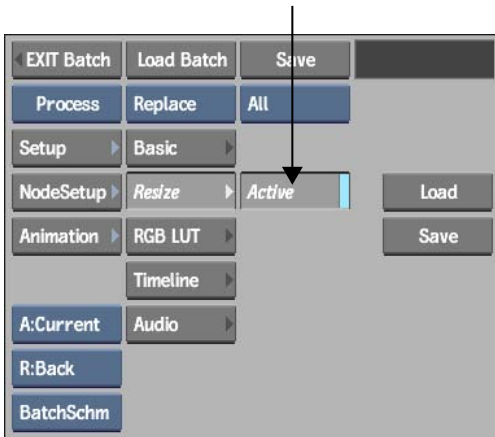

- 7 Set the resize settings. See:
 - [Resizing from Source Using the Crop Box](#) on page 685
 - [Resizing to Destination Using the Crop Box](#) on page 687
 - [Animating Resize Settings](#) on page 688

Resizing from a Clip

When you add clips to the Batch schematic, the clip's menu includes resize settings. Using the clip menu's resize settings:

- You define resize settings at the very start of the processing pipeline.
- Unlike using resize settings from the Clip Library menu, you have access to the crop box and you can animate resize settings.
- You can lock the resize result to the crop box to animate the frame size.
- You can toggle the resize settings on and off.

To access resize settings from a clip:

- 1 Drag a Desk or Library node to the Batch schematic.
- 2 Select the clip that you want to work with in Batch.
- 3 Load the clip:
 - If you are selecting clips on the desktop, click EXIT Clip Select.
 - If you are selecting clips in a clip library, click Load.

The selected clip appears on the Batch schematic.

- 4 Select the clip to view its menu.
- 5 Select Resize.

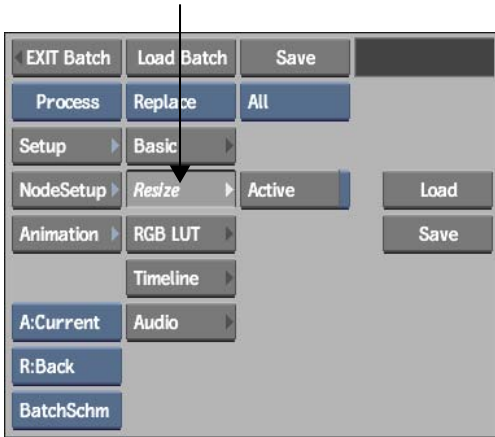

The Resize menu appears.

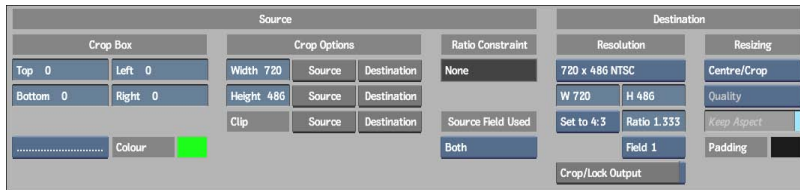

By default, it is set to resize the clip to the project's default resolution.

6 Enable Active.

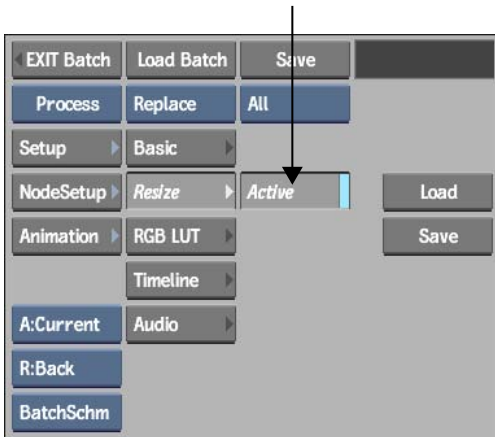

- 7 Set the resize settings. See:
 - [Resizing from Source Using the Crop Box](#) on page 685
 - [Resizing to Destination Using the Crop Box](#) on page 687
 - [Animating Resize Settings](#) on page 688

Resizing from a Resize Node

If you want to perform some processes on a clip at full resolution and resize the output of those processes further down the processing pipeline, use the Resize node. Using the Resize node's settings:

- You have access to the same resize settings as you do when you use the Resize module.
- You define resize settings at any point in the processing pipeline.
- You have access to the crop box and you can animate resize settings.
- You can lock the resize result to the crop box to animate the frame size.

To access resize settings from a Resize node:

- 1 Drag a Resize node to the Batch schematic.
- 2 Parent the output of any node whose result you want to resize to the front clip input socket of the Resize node.

NOTE A Resize node accepts only a single (front) input.

- 3 Select the Resize node.

The Resize menu appears. By default, it is set to resize the clip to the project's default resolution.



- 4 Set the resize settings. See:
 - [Resizing from Source Using the Crop Box](#) on page 685
 - [Resizing to Destination Using the Crop Box](#) on page 687
 - [Animating Resize Settings](#) on page 688

Resizing from an Output Node

Use the resize settings in the Output node to resize the result of the processing pipeline to the destination reel on the desktop or to a clip library. Resizing from the Output node can be a good way to deliver to multiple formats and resolutions. Add an Output node for each resolution that you want to deliver to, and set the options accordingly. Using the resize settings from the Output node:

- You define resize settings of result clips as they are processed to the destination reel on the desktop or to a clip library.
- You have access to the crop box and you can animate resize settings.
- You can toggle the resize settings on and off.

To access resize settings from an Output node:

- 1 Drag an Output node to the Batch schematic.
- 2 Parent the output of any node whose result you want to resize to the front clip input socket of the Output node.
- 3 Select the Output node to view its menu.
- 4 Select Resize.

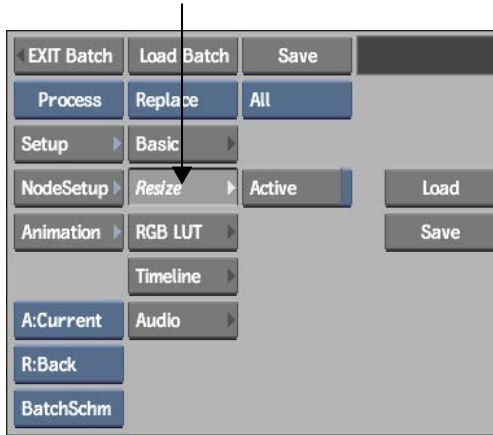

The Resize menu appears. By default, it is set to resize the clip to the project's default resolution.

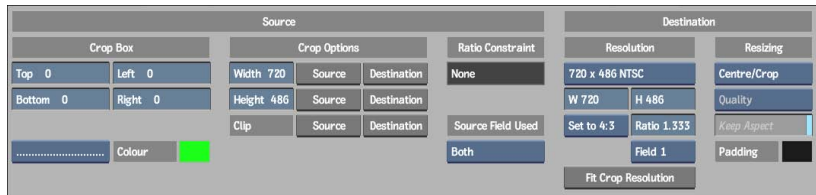

5 Enable Active.

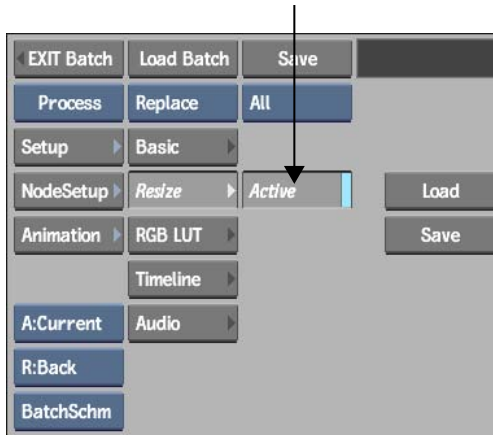

- 6 Set the resize settings. See:
 - [Resizing from Source Using the Crop Box](#) on page 685
 - [Resizing to Destination Using the Crop Box](#) on page 687
 - [Animating Resize Settings](#) on page 688

Resizing from an Export Node

Use the resize settings in the Export node to resize the result of the processing pipeline when exporting to the filesystem. Resizing from the Export node can be a good way to deliver to multiple formats and resolutions. Add an Export node for each resolution you want to deliver to, and set the resize settings accordingly. Using the resize settings from the Export node:

- You define resize settings of result clips as they are processed to the destination reel on the desktop or to a clip library.
- You have access to the crop box and you can animate resize settings.
- You can toggle the resize settings on and off.

To access resize settings from an Export node:

- 1 Drag an Export node to the Batch schematic.
- 2 Parent the output of any node whose result you want to resize to the front clip input socket of the Export node.
- 3 Select the Export node to view its menu.
- 4 Select Resize.

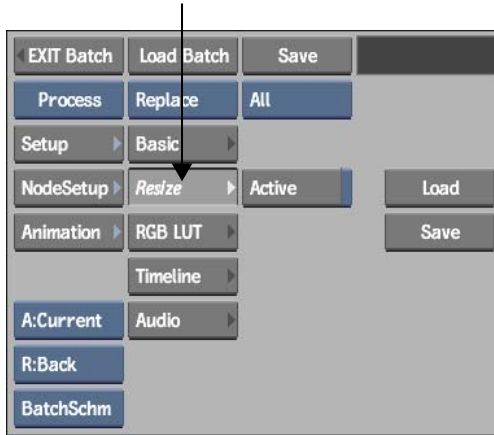

The Resize menu appears. By default, it is set to resize the clip to the project's default resolution.

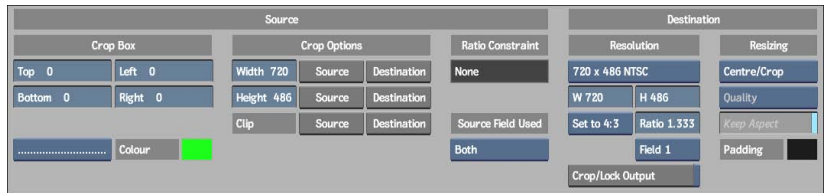

5 Enable Active.

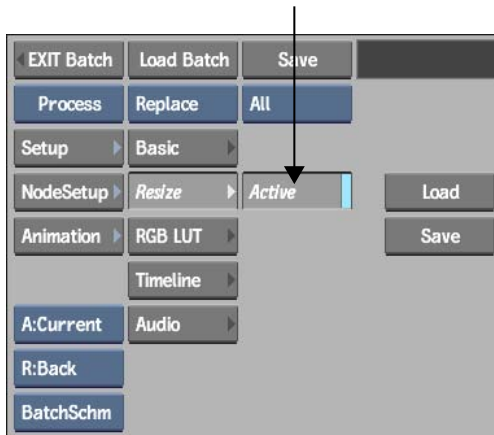

- 6 Set the resize settings. See:
 - [Resizing from Source Using the Crop Box](#) on page 685
 - [Resizing to Destination Using the Crop Box](#) on page 687
 - [Animating Resize Settings](#) on page 688

Soft Resizing a Clip

Use the Resize soft effect to change an element's resolution and bit depth directly on the timeline. This is especially useful when you want to, for example, resize a PAL clip to fit with your NTSC project. This soft effect is automatically applied to clips added to the timeline that do not have the same resolution or scan mode as the current clip.

When you mix clips of different resolution on the timeline, Flame automatically applies a soft Resize using the following attributes:

- Resolution
- Bit depth
- Scan mode (field 1 and field 2 only)

Like any other soft effect, a soft Resize can be applied to a same-resolution segment of the timeline and used to correct blanking problems and even add a “soft” letterbox (this is much faster than using the Axis soft effect). You can also use a soft Resize to apply a border on a clip or to perform a pan and scan and animate the image position to achieve optimal resizing.

Applying a Soft Resize

All clips on the timeline can be resized using a soft Resize. Flame automatically adds or removes a soft Resize when performing mixed-resolution editing. For example, if you created an NTSC clip containing HDTV sources and, later, take the NTSC montage and insert it in an HDTV clip, the HDTV material will no longer have a soft Resize, but the NTSC version will.

To apply a soft Resize on a clip:

- 1 Select the element you want to resize from the timeline.
- 2 Click **Resize** to enable a resize on the selected element.

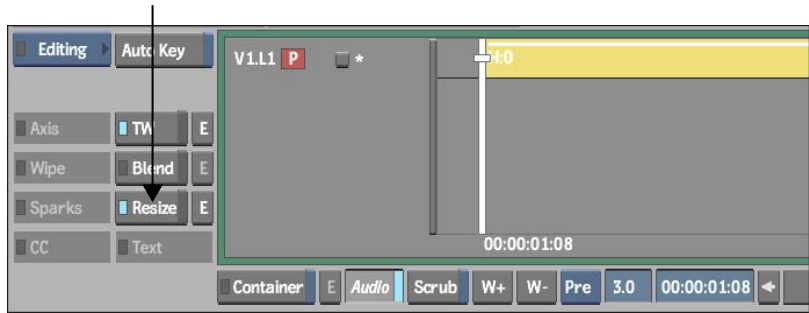

NOTE You cannot mute a Matte container that has a soft Resize.

- 3 Click the E button to display the Resize Editor.

The Resize Editor has a two-player display: source resolution (left) and destination resolution (right). This interface layout is useful for performing a pan and scan resizing. By pressing **Ctrl+Alt+M** on any of the Players, you can “lock” the view on the broadcast monitor. Using the lock feature can let a client monitor the final framing while you continue working on the source image.

TIP You can also apply a soft Resize by pressing **Alt+7**.

Changing Views in Resize and in Batch

When accessed from the desktop or from soft effects, Resize includes a crop box that you use to define the region of the source clip from which the resize sample is taken.

You view the crop box with Front view selected, and the resized result with Result view selected. The most efficient way to work is to set up two viewports for a split view of the front and result views.

To monitor a Split view in Resize:

- 1 Load a clip into Resize or display the soft Resize settings if you are working on the timeline.

With Split view enabled, the viewport on the left displays the front clip and the viewport on the right displays the result clip.



(a) Front clip and crop box (b) Result clip

- 2 To change the view of the active viewport (the active viewport is indicated by a yellow border), select an option from the View box.

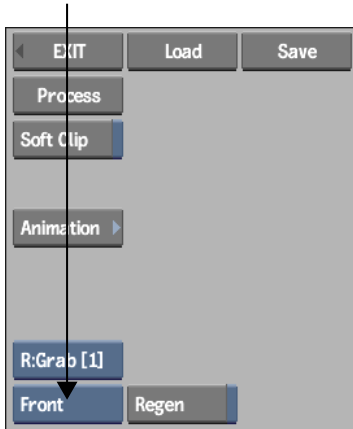

Select:	To view:
Front (or press F1)	The front clip and crop box.
Result (or press F4)	The result clip.
Channels (or press F5)	The Channel Editor.

Select:	To view:
Tracks	The Channel Editor (set to Track view mode). Press F5 to cycle between the Channel Editor view options.
Info	The Channel Editor (set to the Channel Information view mode). Press F5 to cycle between the Channel Editor view options.

Resize Settings

Illustrations in the following sections show the resize settings available in Resize and Resize nodes in Batch. Note the following:

- The crop box settings are not available when you access resize settings from the Import Image, Export Image, or Clip Library menu.
- The destination settings are available in all resize procedures; however, the layout of these controls may change and some options are not available in some cases.

Source Settings

The settings in the Crop Box area are only available when you access resize settings in the Resize module from the desktop or from Batch. Use them to set or animate the position and size of the crop box.

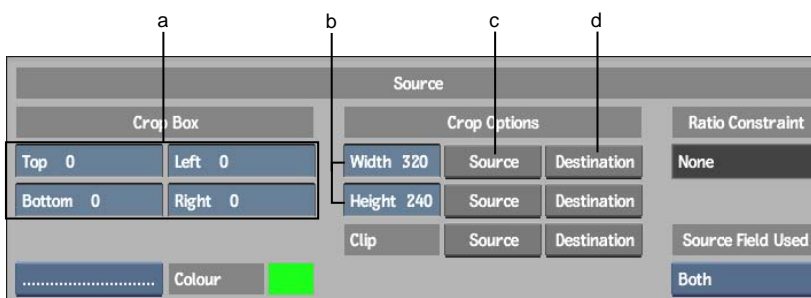

(a) Top, Bottom, Left, Right, Crop fields (b) Crop Box Width/Height fields (c) Source Frame Crop Box button (d) Destination Frame Crop Box button

Ratio Constraint label This locked field indicates the aspect ratio constraint applied while interacting with the crop box:

- If you resize the crop box while pressing **Shift**, the field displays **Proportional**, meaning the crop box retains the aspect ratio it had when you started resizing it.
- If you resize the crop box while pressing **Shift+S**, the field displays **Source**, meaning the crop box locks to the aspect ratio of the source clip.
- If you resize the crop box while pressing **Shift+D**, the field displays **Destination**, meaning the crop box locks to the aspect ratio of the destination format.

Top/Bottom/Left/Right Crop fields Use these fields to enter offsets from the left, top, right, and bottom edges of the source frame.

Crop Box Width/Height fields Use these fields to enter the width and height of the crop box.

Source buttons Click to fit the crop box width or height to the source frame.

Destination buttons Click to fit the crop box width or height to the destination resolution.

Source Field Used box Select an option from **Both**, **Field 1**, **Field 2**, or **Field Merge** to use for the resize operation. This option can be used to improve material that is being converted from an interlaced to a progressive format. If both source and destination formats are interlaced, or if both are progressive, the **Both** option produces the best results.

Destination Settings

The destination settings appear in all resize procedures. These settings define the destination format into which the source sample is fit. The layout of these settings and the availability of some options depends on where you access the resize settings.

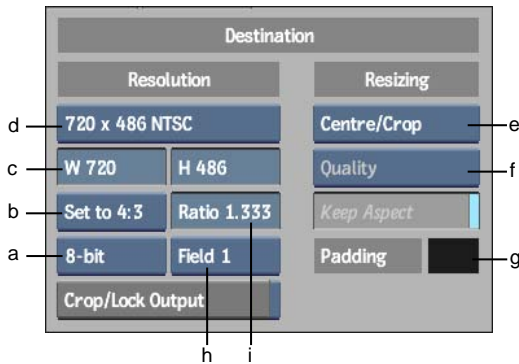

(a) Frame Depth box (b) Resolution Presets box (c) W/H fields (d) Frame Aspect Ratio Presets box (e) Fit Method box (f) Filter box (g) Padding colour pot (h) Scan Mode box (i) Ratio field

Crop/Lock Output button Enable to lock the destination resolution per-frame to match the crop box. Use this option to animate the resolution of a clip. This option is only available when you access resize settings from Clip nodes and the Resize node in Batch. See [Animating Resize Settings](#) on page 688.

Frame Depth box Provides five frame depth options: 8 bit, 10 bit, 12 bit u, 12 bit, or 16 bit fp.

Resolution Presets box Provides options for many standard resolutions, as well as a Custom option that you can use to specify non-standard resolutions.

W/H fields Display the frame width and height of the selected resolution preset. If you select Custom from the Resolution Presets box, use these fields to enter the frame width and height values you want to use.

Frame Aspect Ratio Presets box Provides standard frame aspect ratio options as well as a w:h option to set the clip to use square pixels. Also provides a Custom option so you can enter a custom frame aspect ratio in the Ratio field.

Fit Method box Provides four fit methods.

Select: **To:**

Centre/Crop Fit the source image, centred, over the destination resolution frame. If the source is larger than the destination, it is cropped. If the source is smaller than the destination, it is surrounded by a black border.

Select:	To:
Crop Edges	Fit one edge of the source into the destination resolution frame without stretching or squashing the frame. Excess parts of the source frame after resizing are cropped. If the source—after the one edge is resized—is wider than the destination, its overhanging left and right edges are cropped. If the source is taller than the destination, the upper and lower edges are cropped.
Fill	Fit the source, width and height, into the destination resolution frame. This process, if the source and destination resolutions do not have the same aspect ratio, can distort the image.
Letterbox	Fit the source to the destination resolution frame without squashing or stretching it, and without cropping the source. If the source is wider than the destination, black bars fill the top and bottom of the destination frame. If the source is narrower than the destination, black bars fill the right and left sides of the frame. In all cases, the entire source frame is fit in the destination frame.

Filter box Provides five resizing filters. This box does not appear if you selected the Centre/Crop Fit method.

Select:	To:
Coarse	Get the poorest results in the least amount of processing time. A segment with a soft Resize can be played back in real time when using the Coarse resizing filter. Other options may require rendering.
Medium	Get moderate results. Processing time is increased compared to Coarse.
Quality	Get very good results when resizing a clip to a lower resolution. Processing time is increased compared to Medium.
Bicubic	Get the best results when resizing a clip to a higher resolution. Processing time is increased compared to Medium, but decreased compared to Quality.
Lanczos	Get the best results when resizing a clip to a lower resolution. It uses the Lanczos algorithm, which is an iterative algorithm particularly useful for finding decompositions of very large sparse matrices.

NOTE Defining a filter method in a resize menu will override the default setting specified in the Preferences menu.

Keep Aspect button Enable to maintain non-square pixel formats. This button only appears if you selected the Crop Edges or Letterbox methods.

Padding colour pot Select a colour to use for padding out the frame when centre-cropping, cropping edges, or letterboxing. The default padding colour is black.

Scan Mode box Provides four Scan Mode options.

Select:	To resize:
Progressive	A frame-based clip to another frame-based clip.
Field 1	A clip by drawing Field 1 followed by Field 2.
Field 2	A clip by drawing Field 2 followed by Field 1.
Field Merge	A clip by fully merging both fields in each frame.

For interlaced material, you can specify whether the resize needs to be done from both fields or just from one of the two. In the latter case, the result is going to be a progressive clip made from the same two fields.

Use Field Merge to remove the effects caused by field jitters.

Ratio field Enter a custom frame aspect ratio in this field, if necessary.

Resizing from Source Using the Crop Box

Using the more complete resize settings in Resize, Resize nodes in Batch, or in the Resize soft effect, you can set or animate the position and size of the crop box and have a dynamic preview from which to view results while setting the resize settings.

In this section, you resize the entire source frame to the destination resolution using the Fill and Letterbox fit methods:

- The Fill fit method produces the best results when the source and destination resolutions are the same aspect ratio, such as when resizing from NTSC to PAL, or from any of the 4:3 full-aperture flat film formats (2048x1536) to NTSC/PAL.
- The Letterbox fit method is good for resizing a 16:9 clip to a 4:3 clip without losing any of the 16:9 original.

To resize a clip using the Fill fit method:

- 1 Access the Resize module for a clip on the desktop, in Batch, or from soft effects if you are working on the timeline.
- 2 To fit the entire source frame into the destination frame, the crop box must be the same size as the source frame and aligned along its edges. Do one of the following:
 - In the Width and Height fields, enter the source frame resolution values. Make sure the crop box is centred over the front clip.
 - Click the Source button next to the Clip label to match the crop box width and height to the source clip.
- 3 From the Resolution Presets box, select the destination resolution. You can also select Custom and then enter width and height values in the W and H fields.

The destination resolution should be the same aspect ratio as the source. If not, the resize process (using the Fill fit method) will stretch or squash the clip.

NOTE You are not able to define the output resolution in the Soft Resize menu. The output resolution is determined by the project's resolution.

- 4 From the Fit Method box, select Fill to fit the source, width, and height to the destination resolution.
- 5 From the Filter box, select a filter option. See [Destination Settings](#) on page 682.
- 6 Depending on the source and destination resolutions, select a scan mode from the Scan Mode box. See [Destination Settings](#) on page 682.
- 7 Process the result.

To resize a 16:9 source clip to a 4:3 destination resolution using the Letterbox fit method:

- 1 Access the Resize module for a 16:9 clip on the desktop, in Batch, or from soft effects if you are working on the timeline.
- 2 Click the Source button next to the Clip label to make the crop box the same size as the source frame.
- 3 From the Resolution Presets box, select a 4:3 destination resolution. You can also set custom width and height in the W and H fields.

- 4 From the Fit Method box, select Letterbox.
Black bars appear above and below the source frame, which itself is resized to fit the destination frame.
- 5 From the Filter box, select a filter option. See [Destination Settings](#) on page 682.
- 6 Depending on the source and destination resolutions, select a scan mode from the Scan Mode box. See [Destination Settings](#) on page 682.
- 7 Process the result.

Resizing to Destination Using the Crop Box

Using the more complete resize settings in Resize, or the Resize nodes in Batch, you have a dynamic preview from which to view results while setting the resize settings.

In this section, learn to resize to destination. In the first procedure, extract a 4:3 cutout from a 16:9 clip. In the second procedure, extract a custom cutout from a source clip.

To extract a 4:3 cutout from a 16:9 clip:

- 1 Access the Resize module for a 16:9 clip on the desktop, in Batch, or from soft effects if you are working on the timeline.
- 2 Click the Source button next to the Clip label to make the crop box the same size as the source frame.
- 3 Make sure Regen is enabled to get dynamic visual feedback of the result clip in the viewport on the right. See [Getting Dynamic Feedback in Result View](#) on page 693.
- 4 From the Resolution Presets box, select the 4:3 resolution to which you want to resize the source.
- 5 Make sure Keep Aspect is enabled.
- 6 From the Fit Method box, select Crop Edges.
- 7 Depending on the source and destination resolutions, select a scan mode from the Scan Mode box. See [Destination Settings](#) on page 682.
- 8 Process the result.

To extract a custom cutout from a source clip:

- 1 Access the Resize module for a 16:9 clip on the desktop, in Batch, or from soft effects if you are working on the timeline.
- 2 From the Resolution Presets box, select the 4:3 resolution to which you want to resize the source.
- 3 Click the Destination button next to the Clip label to make the crop box the same size as the destination frame.
By default, the crop box is centred.
- 4 To make an off-centre cutout, drag the crop box to another position.
- 5 From the Fit Method box, select Centre/Crop.
- 6 Depending on the source and destination resolutions, select a scan mode from the Scan Mode box. See [Destination Settings](#) on page 682.
- 7 Process the result.

Animating Resize Settings

You can animate the position of the crop box to pan and scan a 16:9 clip to a 4:3 format. Pan and scan is a technique widely used for resizing 16:9 clips to a 4:3 resolution when the area of interest in the shots is to one side of the 16:9 frame. You can follow the area of interest in the shot by animating the crop box along the X-axis.

You can also animate the size of the crop box and lock the output to the crop box. This animates the resolution of the clip, meaning that the second frame of the clip is different from the first. You can do this only in Batch.

To pan and scan a 16:9 clip to a 4:3 clip:

- 1 Access the Resize module for a 16:9 clip on the desktop, in Batch, or from soft effects if you are working on the timeline.
- 2 Make sure Regen is enabled to get dynamic visual feedback of the result clip in the viewport on the right. See [Getting Dynamic Feedback in Result View](#) on page 693.
- 3 From the Resolution Presets box, select the 4:3 resolution to which you want to resize the source.
- 4 From the Fit Method box, select Crop Edges.

- 5 Click the Source button next to the Clip label to make the crop box the same size as the source frame.
- 6 Depending on the source and destination resolutions, select a scan mode from the Scan Mode box. See [Destination Settings](#) on page 682.
- 7 Go to the first frame.
- 8 Make sure Autokey is enabled so you can create position keyframes for the crop box automatically.
- 9 Scrub through the clip to identify areas where the area of interest includes the left and right edges of the clip outside the crop box.
- 10 Animate the position of the crop box accordingly by dragging the crop box. Press **Shift** while dragging the crop box to constrain changes in position to the X-axis:
 - If the area of interest changes suddenly following a splice between clips, add a keyframe for the X-position of the crop box at the last frame of the outgoing shot, and then add another keyframe at the first frame of the incoming shot.
 - If the area of interest changes with camera movement, create a linear or hermite animation to change the X-position of the crop box gradually.
- 11 Depending on the source and destination resolutions, select a scan mode from the Scan Mode box. See [Destination Settings](#) on page 682.
- 12 Process the result.

Saving and Loading Resize Setups

If you are working in Resize, Resize nodes in Batch, or with the soft Resize settings, you can save resize setups and load them for use with other clips.

To save a setup in Resize:

- 1 In Resize, click Save.

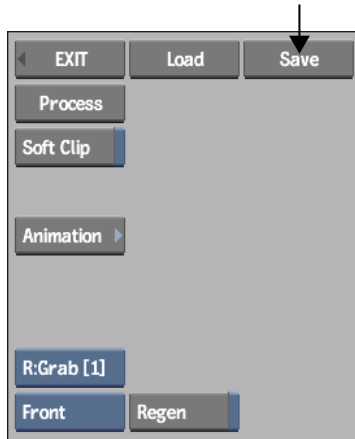

The file browser appears.

- 2 Enter a name for the setup file and then click Save.

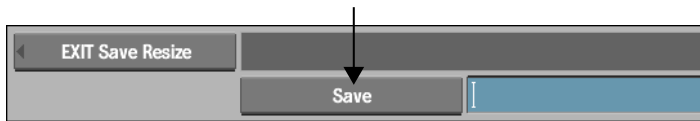

TIP By default, setups are saved to the *resize* directory in your project's home directory.

- 3 Click EXIT Save Resize.
You are returned to the Resize menu, and the setup name appears in the upper-left corner of the menu area, in a black uneditable field.
- 4 Once you save a setup, you can continue modifying the resize settings. To update the most recently saved setup with your most recent changes, click Save, next to the setup name, and then Confirm.

To save a resize setup in Batch:

- 1 Display the Resize menu:
 - If you are saving the setup for a Resize node, select the node.
 - If you are saving the setup for a clip, select the clip and then select Resize from the Edit box.
- 2 Click Save.

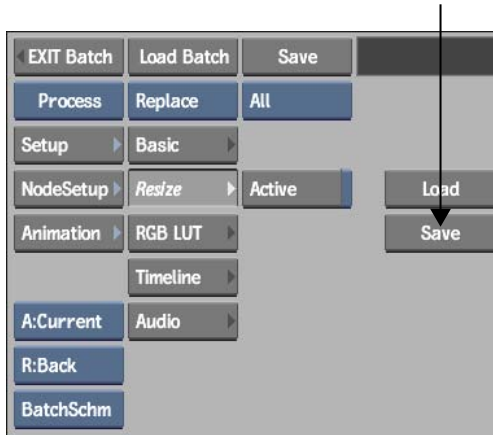

- 3 Enter a name for the setup file and then click Save.

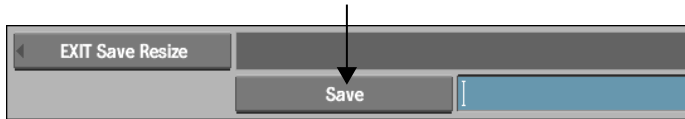

TIP By default, setups are saved to the *resize* directory in your project's home directory.

- 4 Click EXIT Save Resize.
You are returned to the Resize menu, and the setup name appears in the upper-left corner of the menu area, in a black uneditable field.

To load a setup in Resize:

- 1 In Resize, click Load.

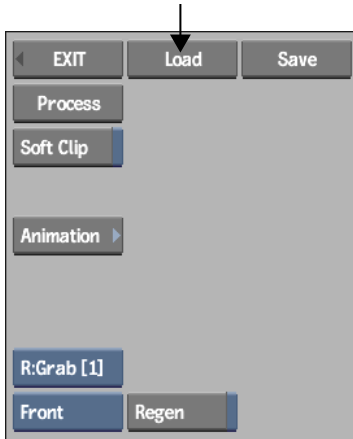

The file browser appears.

- 2 Locate the setup file that you want to load, select the file, and then click Load.

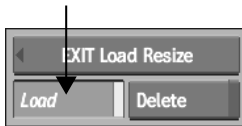

To load a resize setup in Batch:

- 1 Display the Resize menu:
 - If you are saving the setup for a Resize node, select the node.
 - If you are saving the setup for a clip, select the clip and then select Resize from the Edit box.
- 2 Click Load.

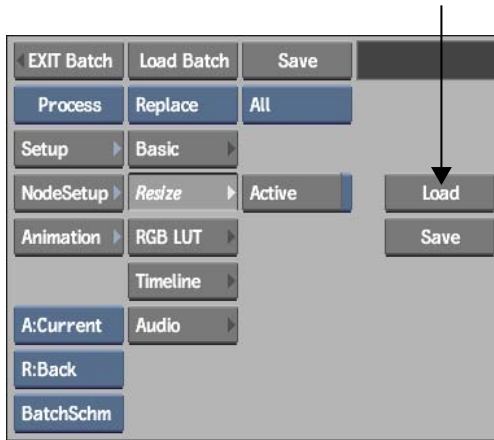

The file browser appears.

- 3 Locate the setup file that you want to load, select the file, and then click Load.

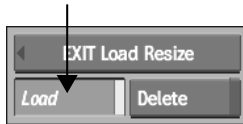

Getting Dynamic Feedback in Result View

You can view the effects of resize settings dynamically in Result view. This option is available only in the Resize menu accessed from the desktop.

To get dynamic feedback in Result view:

- 1 Enable Regen.

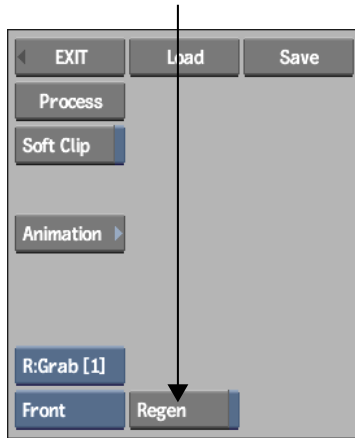

TIP When you resize clips in Batch, dynamic feedback is always provided.

Processing Clip Handles When Working with Soft Clips

When you resize clips on the Desktop that have soft edits such as dissolves, you can process all frames that are part of the dissolve and keep the soft edits intact. That way, if you want to change the dissolve, resized handle frames are available.

To process all frames associated with a soft clip:

- 1 Enable Soft Clip.

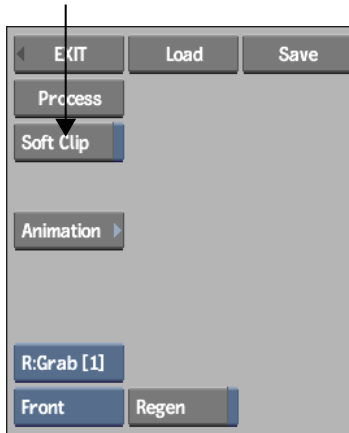

NOTE You can only process clip handles if you do not animate the crop box. If you animate the crop box, the Soft Clip button is inactive.

Resetting All Resize Settings to Default Values

You can reset resize settings to their default values in Resize and the Resize nodes in Batch.

To reset all settings in Resize to the default values:

- 1 In Resize, click Reset All.



- 2 Click Confirm to reset all resize values.

TIP You can also click Reset All in the Animation menu. Doing so resets only animatable values. Other settings such as the fit method, scan mode, and other non-animatable settings remain unchanged.

To reset all settings of a Resize node in Batch to the default values:

- 1 Select the clip or node on the Batch schematic.
- 2 From the Resize menu, click Reset.



The clip's resize settings are reset. Basic settings, as well as settings for LUTs and the editing timeline, are unaffected.

Changing the Appearance of the Crop Box

By default, the crop box is green. If there is a lot of green in the clip you are resizing, you may want to change the colour of the crop box to see it better. You can also change the line type with which the crop box is drawn.

To change the appearance of the crop box:

- 1 Click the colour pot to display the colour picker.

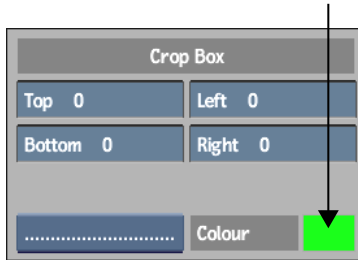

- 2 Use the colour picker to set the colour of the crop box.
- 3 To change the line type of the crop box, select an option from the Line Type box.

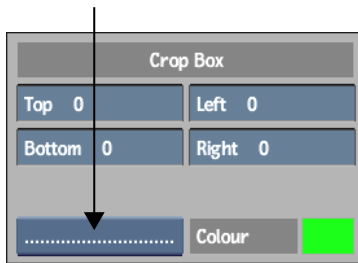

Changing the Padding Colour

The default padding colour when centre-cropping, cropping edges, or letterboxing, is black. You can set the padding to any other colour.

To change the padding colour:

- 1 Click the colour pot beside the Padding title to display the colour picker.

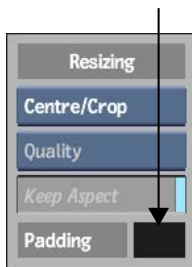

- 2 Use the colour picker to set the colour of the letterbox padding.



Setting Default Image Resolution Characteristics on Import

You can force a common aspect ratio, scan mode, and frame rate for all images selected for import.

Alternatively, you can use the Default Resolutions list to set the aspect ratio, scan mode, and frame rate for the import based on the width and height of the individual image. This is useful when you want to import multiple images of varying dimensions.

To force a common aspect ratio, scan mode, and frame rate:

- 1 In the Import Image menu, disable Resize.

Only the Aspect Ratio box and the Aspect Ratio field remain enabled in the Resize options.

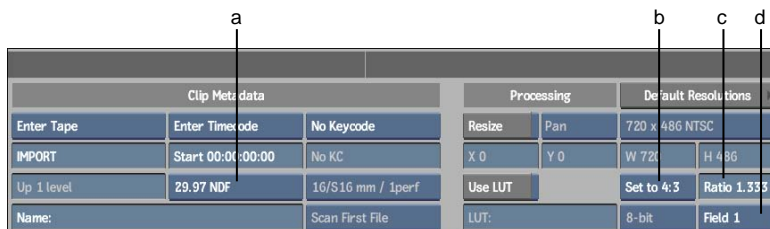

(a) Framerate box (b) Aspect Ratio box (c) Aspect Ratio field (d) Field Dominance box

- 2 Select a value from the Aspect Ratio box or enter a value in the Aspect Ratio field.
 Specifying a unique aspect ratio in the Aspect Ratio field causes the Aspect Ratio box to show Custom automatically.
 Specifying Default allows you to apply a preset resolution from the Default Resolutions list.
- 3 Use the Field Dominance box and the Framerate box to set the scan mode and frame rate, respectively, for all the selected images.

To use the Default Resolutions list to determine aspect ratio, scan mode, and frame rate:

- 1 In the Aspect Ratio box, select Default.
- 2 To view/edit the Default Resolutions list, click Default Resolutions. See [Default Resolutions List](#) on page 699.

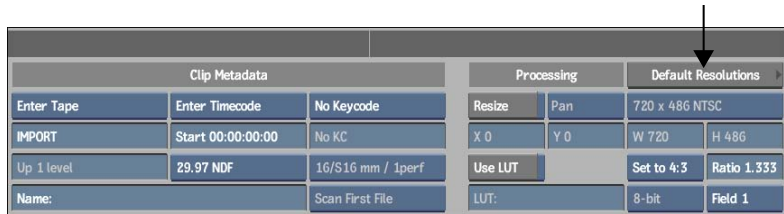

Clip Metadata			Processing		Default Resolutions	
Enter Tape	Enter Timecode	No Keycode	Resize	Pan	720 x 486 NTSC	
IMPORT	Start 00:00:00:00	No KC	X 0	Y 0	W 720	H 486
Up 1 level	29.97 NDF	16/S16 mm / 1perf	Use LUT		Set to 4:3	Ratio 1.333
Name:		Scan First File	LUT:		8-bit	Field 1

Default Resolutions List

The Default Resolutions list determines the aspect ratio, scan mode, and frame rate to apply to an image with a specific width and height. It is consulted during import when you select Default in the Aspect Ratio box of the Import Image menu.



(a) Edit Mode box (b) Current project resolution (c) Edit controls

The list displays the contents of the `/usr/discreet/cfg/legacy.res.cfg` file. If this file does not exist, the system defaults for each resolution are used, such as 1.33 for NTSC and PAL.

The default resolution of the current project appears in red. You can edit any item in the list, as well as add or remove items. If you edit the default resolution of the current project, the edit is in effect only for the current session. The next time you open the project, the resolution reverts to that stored with the project.

To display the Default Resolutions list:

- 1 In the Import Image menu, click Default Resolutions.

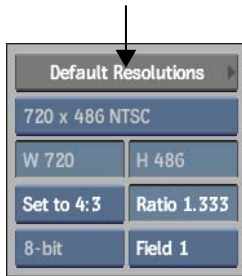

The Default Resolution list appears.

To add a resolution to the list:

- 1 In the Edit Mode box, select Add Resolution.
- 2 Use the Edit controls to enter the width, height, aspect ratio, scan mode, and frame rate for the new resolution.
- 3 Click Apply Changes.

To edit a resolution:

- 1 In the Edit Mode box, select Edit Resolution.
- 2 In the Default Resolutions list, select the resolution you want to edit.
- 3 Use the Edit controls to adjust any of the following: width, height, aspect ratio, scan mode, or frame rate.
- 4 Click Apply Changes.

To remove a resolution:

- 1 In the Edit Mode box, select Remove Resolution.
- 2 In the Default Resolutions list, select the resolution you want to remove.
- 3 Click Apply Changes.
You are prompted to confirm the deletion.
- 4 Click Confirm to delete the selected resolution from the list.

2:3 Pulldown

27

Topics in this chapter:

- [About 2:3 Pulldown](#) on page 703
- [Capturing Film-Based Media with 2:3 Pulldown Removal](#) on page 705
- [Capturing Film-Based Media with 2:3 Pulldown Using EDLs](#) on page 708
- [Saving and Loading the Tape List](#) on page 710
- [Removing and Inserting Pulldown on the Desktop](#) on page 712
- [Monitoring Dual Timecodes and 2:3 Pulldown](#) on page 715
- [Outputting a Clip to Tape with 2:3 Pulldown Insertion](#) on page 717
- [Exporting EDLs with 2:3 Pulldown Insertion](#) on page 718

About 2:3 Pulldown

2:3 Pulldown is added when 24 fps film material is transferred to 60i tapes using the telecine method. The same images that made up 24 frames of film must now make up 30 frames of video. In other words, for every 24 film frames six “new” video frames must be added. To accomplish this, the film frames are first divided into fields. The fields are then distributed across frames in a regular pattern to create the new frames with the smoothest results and least disturbance of the original material.

There are two kinds of pulldown:

- In 2:3 pulldown, the first frame of film is used in two fields of video, while the second is used in three.
- In 3:2 pulldown, it is the first frame that becomes three fields, while the second becomes just two.

Regardless of the kind of pulldown used, the resulting pattern is the same. The converted video consists of sequences of three intact film frames separated by two hybrid frames.

While the intact frames are identical to their sources, the hybrids consist of fields from two different film frames. If viewed as stills, the hybrid frames appear jittery—because the fields do not originate from the same moment in time. (When played back in the full sequence, the jitter is virtually imperceptible.) When working with 24p sources in Flame, it is important to keep the jitter frames in mind. These are the markers for setting up the automatic pulldown removal on capture.

NOTE The procedures in this chapter refer to 2:3 pulldown, but apply equally to 3:2 pulldown. Where necessary, the distinction between the two is made explicitly.

The pulldown transfer process is as follows:

- 1 The process begins with four frames of film.



- 2 The four frames are divided into fields.

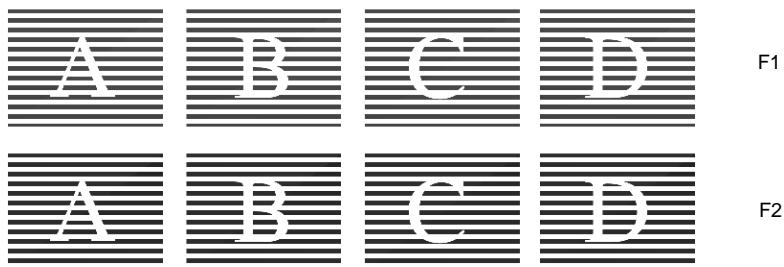

- 3 The fields are resequenced using 2:3 or 3:2 pulldown and recorded to the 60i tape.
 - 2:3 pulldown



- 3:2 pulldown



2:3 Pulldown Tools

Flame includes the following 2:3 pulldown tools and features:

- Real-time pulldown removal on video capture
- Auto-capture from EDLs with automatic, real-time pulldown removal
- Real-time pulldown insertion during playback
- Dual timecode display on the Player
- Real-time pulldown insertion on video output
- Exporting of EDLs from 24p masters as 60i with field-based accuracy for final tape-to-tape colour grading

Capturing Film-Based Media with 2:3 Pulldown Removal

Using the Input Clip menu, you can capture 30 fps film-based material and convert it to 24 fps material in real time as you capture. The procedure for enabling automatic 2:3 removal differs depending on whether your tape uses non-drop or drop 60i timecode.

To capture material with 2:3 pulldown removal:

- 1 Open the clip library to where you want to store the clips that you are importing.
- 2 Click Input Clip.
- 3 In the Input Clip menu, select a VTR from the Device Name box.

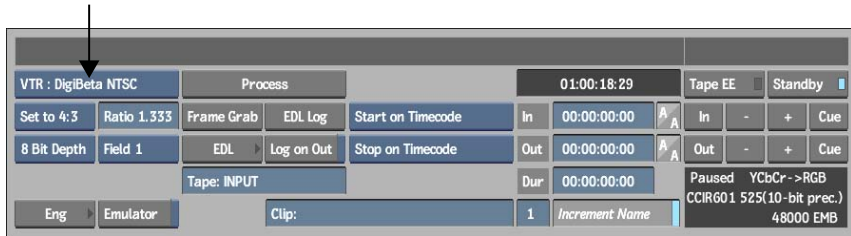

- 4 Enable the channels that you want to capture. See [Capturing Single Clips](#) on page 152.
- 5 Name the tape and the clip you are about to capture. See [Naming Tapes and Clips](#) on page 150.
- 6 Click Eng.

The Engineering menu appears. It contains options for removing 2:3 pulldown in real time while capturing.

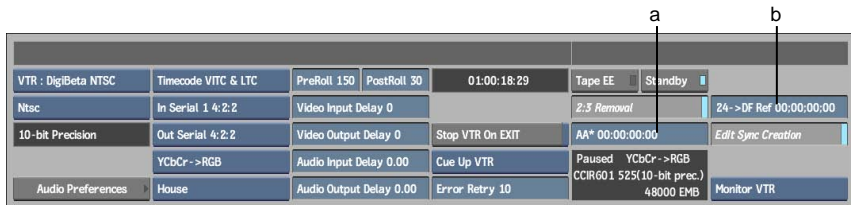

(a) AA Reference field (b) 24>DF Reference field

- 7 Enable 2:3 Removal.
- 8 In the AA Reference field, enter a timecode that corresponds with an AA frame on the tape that is currently in the VTR.

TIP To determine an AA frame, frame-step (**right arrow**) the tape and look closely at each frame. In 2:3 pulldown, two jitter frames with field artefacts are followed by three normal frames. The second frame after the two jitter frames is an AA frame. Many VTRs display fields instead of frames, so you will not see any jitter. In this case you can see that field A appears 2 times, followed by field B appearing 3 times, field C appearing 2 times, field D appearing 3 times, and so on.

- 9 When you capture material from a tape that uses 30 fps drop-frame timecode with 2:3 removal enabled, a slight discrepancy between timecodes is introduced due to the reference timecode used to determine the 30 drop frame to 24 timecode conversion. To optimize correspondence between the timecodes, enter the timecode in the 24 >DF Reference field that matches the start reel timecode for the tape.

TIP The start clip timecode can be deduced from the hour-mark of the timecode used by your clips. For example, 1;00;00;00 drop-frame would require a 1;00;00;00 value in the 24p>DF reference field to get a clip starting at 01;00;00+00.

- 10 Click EXIT to return to the Input Clip menu.
- 11 Using the In and Out timecode fields, set the in and out points for the capture session.

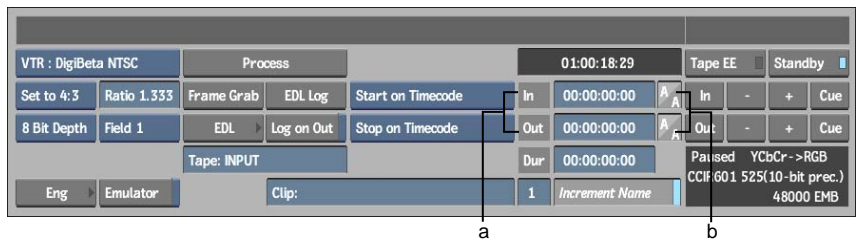

(a) In and Out timecode fields (b) 2:3 In and Out pulldown display

With the in and out timecodes set, the corresponding 2:3 pulldown frame is indicated in the In and Out 2:3 pulldown display. Use the 2:3 pulldown display to determine the 24 fps result in and out frames.

- 12 Click Process to capture the material with 2:3 pulldown removal.

Capturing Material from Tapes with Inconsistent 2:3 Pulldown

If a 60i tape contains film-based material that was transferred to the tape in different sessions, it is possible that the 2:3 pulldown from one session to the next is not consistent. If your 30 fps EDL refers to material across different sections of the tape with different 2:3 pulldown, you will be unable to capture with automatic 2:3 removal configured for the entire tape. Setting a reference frame for the tape would properly capture the section you referenced, but not others. Instead, you can capture the clips as is, then remove the pulldown on the Desktop. See [Removing and Inserting Pulldown on the Desktop](#) on page 712. You can also change the reference frame at each capture, and capture multiple times.

Capturing Film-Based Media with 2:3 Pulldown Using EDLs

Most offline editing of film-based material transferred to 60i tape results in a 30 fps EDL. You can set up an auto-capture session using the 30 fps EDLs, applying 2:3 pulldown removal to both the EDLs and the captured clips.

By previewing the 30 fps EDL converted to 24 fps, you can identify splices that fall on hybrid frames—the result of the 60i offline edit—and, if necessary, edit the EDL prior to auto-capture.

Importing EDLs With 2:3 Pulldown

Before you begin importing EDLs with 2:3 pulldown, you should put all the EDLs that you want to import into a single directory on the filesystem accessible from Flame.

Ensure that you have a list of 2:3 pulldown reference frames for all tapes to which the EDLs refer. If you do not know the 2:3 pulldown on your tapes, load the tapes into your VTR and then open the Input Clip menu. Frame-step (**right arrow** and **left arrow**) through the tape to take note of the reference frame and type (AA/BB/BC/CC/DD).

This section covers the Import EDL menu only in terms of conforming 30 fps EDLs with automatic 2:3 removal. For complete information on the Import EDL menu, see [Importing EDL Files](#) on page 321.

To import an EDL file with 2:3 pulldown removal:

- 1 Follow the general procedure for importing an EDL file, and stop at the point where you can set any options in the Import EDL menu. See [Importing EDLs](#) on page 335.
- 2 Enable 2:3 Removal Mode.
- 3 From the Frame Code Mode box, select the option that corresponds to the EDLs you are loading.
When 2:3 Removal Mode is enabled, the only options are 29.97 fps and 30 fps. If you are loading multiple EDLs, the same frame code mode is used for all of them.
- 4 To ensure match frames on timewarped elements are maintained, enable Fix TW Match Frames.
- 5 Continue the procedure for importing an EDL file.
Your EDL file is imported with 2:3 pulldown.

Setting Default 2:3 Pulldown Configuration Options

You can set default 2:3 pulldown sequence reference frames for all tapes and record clips. In cases where you frequently receive tapes that require 2:3 removal, it is a good idea to communicate with your client so 2:3 sequence is inserted consistently for all tapes. That way, your default settings configure an accurate 2:3 removal process without you having to manually enter reference frames tape-to-tape.

You can also set preferences to highlight and correct hybrid frames, and to apply a timewarp fit to native 30 fps interlaced material referenced by EDLs for which 2:3 removal is disabled. That way, native 30 fps material can be integrated in 24 fps timelines more easily. See [2:3 Pulldown Options Menu](#) on page 333.

To set the default source 2:3 pulldown (for material on tapes provided to you), select a frame type. You do not have to enter a reference timecode.

- If the lowest timecode referenced for a tape by an EDL is an even hour (for example, 01:00:00:00), the reference frame is applied to that frame.
- If the lowest timecode referenced for a tape by an EDL is not an even hour (for example 01:00:01:22), the reference frame is applied to the next even-hour downward (for example, 01:00:00:00).

You can override these default settings on a tape-to-tape basis. See [Overriding Default 2:3 Pulldown Configuration Tape-to-Tape](#) on page 710.

Overriding Default 2:3 Pulldown Configuration Tape-to-Tape

You can override default 2:3 pulldown configuration options on a tape-to-tape basis. Do so when you are provided with tapes that have a 2:3 pulldown sequence that does not match the default settings, or to disable 2:3 removal for tapes that contain native 30 fps material.

To override default 2:3 pulldown configuration tape-to-tape:

- 1 In the Import EDL menu, enable View Tape List.
The tape list displays information about each tape referenced by currently loaded EDLs.
- 2 To view 2:3 pulldown configuration information, click the triangle on the left of the tape entry to expand its contents.
Columns indicate whether 2:3 removal is enabled, and, if it is, the reference frame and type for the 2:3 sequence on the tape.

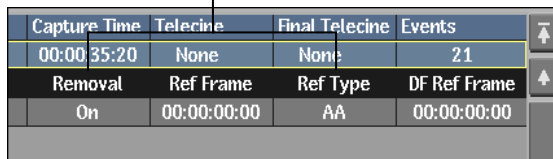

Capture Time	Telecine	Final Telecine	Events
00:00:35:20	None	None	21
Removal	Ref Frame	Ref Type	DF Ref Frame
On	00:00:00:00	AA	00:00:00:00

- 3 Drag over the entry in the 2:3 Removal column to turn 2:3 removal on or off.
- 4 To set the reference frame, enter a timecode in the Ref Frame column.
- 5 To set the reference frame type, drag over the Ref Type column.

Saving and Loading the Tape List

In cases where you may want to recapture or reassemble clips from EDLs more than once, it is a good idea to save the tape list (which stores the 2:3 pulldown configuration for each tape) so you can load it later. You can also use an R23

file to keep track of the key frames for all start frames of all the tapes referenced in an EDL. R23 files are accessible via the Import and Export EDL menus.

To save a tape list:

- 1 In the Import EDL menu, click Save.
- 2 In the Save EDL menu, select Tape List from the Save Option box.



- 3 Use the file browser to set the destination for the saved file.
By default the tape list is saved in your project's `~/edl` directory.
- 4 In the Name field, enter a name for the tape list.
By default the tape list is saved with the `.dtl` extension.
- 5 Click Save.

To load a tape list:

- 1 In the Import EDL menu, click Load.
- 2 In the Load EDL menu, select DTL (Discreet Tape List) from the File Extension box.

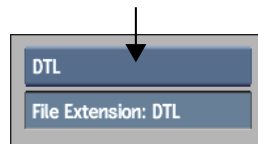

- 3 Use the file browser to locate and select the tape list.
- 4 Click Load.

Removing and Inserting Pulldown on the Desktop

Although 24p projects allow you to remove 2:3 or 3:2 pulldown from film-based sources on 60i tapes during the capture process, you can also capture the 60i sources as is, and then remove pulldown on the Desktop.

Desktop-based removal and insertion is also useful if your clips originate from the filesystem and were imported rather than captured from tape. Image import and export does not support automatic pulldown removal.

To remove pulldown on the desktop:

- 1 In the Main menu, click Format.

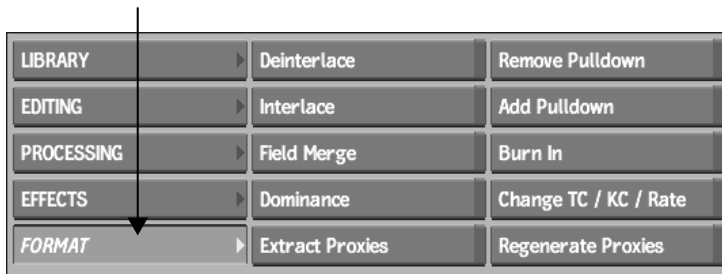

- 2 In the Format menu, click Remove Pulldown.

The pulldown options appear to the right of the menu panel.



(a) Timecode Mode box (b) Start TC Mode box

- 3 From the Timecode Mode box, select an option.

Select:	To:
Keep TC Mode	Keep the 29.97 fps timecode of the clip from which you want to remove pulldown.
Change TC Mode	Change the 29.97 fps timecode to 23.97 fps timecode.

- 4 If you selected Change TC Mode, select an option from the Start TC Mode box.

Select:	To:
Same Start Time	Use the 29.97 fps start timecode of the clip as the 23.97 fps start timecode of the result clip without converting it.
Same Start Frame	Convert the 29.97 fps start timecode of the clip to 23.97 fps and then use the result timecode as the start timecode for the result clip.

- 5 On the desktop reels, expand the clip from which you want to remove 2:3 pulldown: hold the cursor over the clip and press **C**.
- 6 Look closely at the clip. Three smooth frames are followed by two jittery frames. Find a frame that lies immediately to the left of two jitter frames.



NOTE By default, desktop reels are set to play left-to-right. If your desktop preferences are set to play reels right-to-left, click a frame that lies immediately to the right of the two jitter frames.

- 7 To remove the pulldown, click the upper-left corner of that frame.
- 8 Select a destination reel for the processed result.
The new clip with only the original 24 film frames is processed and appears on the destination reel.
- 9 Continue removing 2:3 pulldown from other clips or click the grey area in the menu area below the reels to deactivate the Film Compress command.

To insert pulldown on the desktop:

- 1 In the Format menu, click Film Expand.
Pulldown options appear to the right of the Format menu.

Remove Pulldown	Separate	Delete	Change TC Mode
Add Pulldown	Combine	Name	Same Start Time
Burn In	Interleave	Move	29.97 fps NDF
Change TC / KC / Rate	Deal	Copy	Select position before first
Regenerate Proxies	Resize	LUT	Go To

(a) Timecode Mode box (b) Start TC Mode box (c) Destination Timecode box

2 From the Timecode Mode box, select an option.

Select:	To:
Keep TC Mode	Keep the 23.97 fps timecode of the clip from which you want to insert pulldown.
Change TC Mode	Change the 23.97 fps timecode to 29.97 fps timecode.

3 If you selected Change TC Mode, select an option from the Start Mode box.

Select:	To:
Same Start Time	Use the 23.97 fps start timecode of the clip as the 29.97 fps start timecode of the result clip without converting it.
Same Start Frame	Convert the 23.97 fps start timecode of the clip to 29.97 fps and then use the result timecode as the start timecode for the result clip.

4 From the Destination Timecode box, select the desired timecode for your destination clip.

Select:	To output with:
Auto	29.97 fps drop-frame or non-drop-frame timecode
30 fps	30 fps timecode
29.97 fps DF	29.97 fps drop-frame timecode
29.97 fps NDF	29.97 fps non-drop-frame timecode

- 5 Click the upper-left corner of the clip in which you want to insert pulldown.
- 6 Select a destination frame for the processed result.

Select:	To:
The first frame	Insert 2:3 pulldown. The result clip has the following sequence: AA, BB, BC, CD, DD.
The second frame	Insert 3:2 pulldown. The result clip has the following sequence: AA, AB, BC, CC, DD.

- 7 Select a destination reel for the processed result.
- 8 Continue inserting 2:3 pulldown into other clips or click the grey area in the menu area below the reels to deactivate the Film Expand command.

Monitoring Dual Timecodes and 2:3 Pulldown

When you load 24p clips into the Player, the dual timecode and 2:3 pulldown monitoring options are enabled.

To monitor dual timecodes and 2:3 pulldown:

- 1 Load a 23.97 fps clip into the Player.
The playback rate is set to 23.97 fps. A pulldown frame type display indicates the corresponding pulldown frame type for the clip following pulldown insertion.

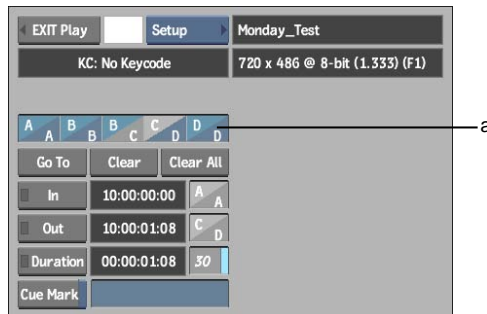

(a) Pulldown frame type display

The pulldown frame type display allows you to keep track of which transitions fall on jitter frames (video frames composed of two different film-based frames). 23.97 fps timecode uses a plus sign for the last punctuation mark, while 29.97 fps timecode uses a colon in non-drop frame mode, or a semi-colon in drop frame mode.

The pulldown frame type display also appears in the Basic menu for all clip nodes in Batch that use 23.97 fps timecode.

- 2 To view the 29.97 fps timecode that corresponds with each frame in the 23.97 fps clip following pulldown insertion, enable 30.

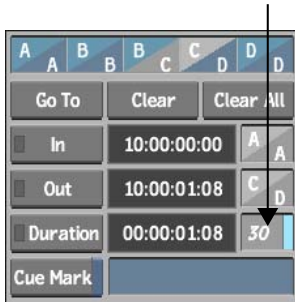

NOTE Timecode 00:00:00:00 on the timeline is always an A-frame, both when you work on the timeline and when you output the final project. This is the reference used to calculate 2:3 insertion when recording to tape.

- 3 To enable real-time 2:3 insertion while playing the 23.97 fps clip, in the Player Menu, enable 2:3 Insert.

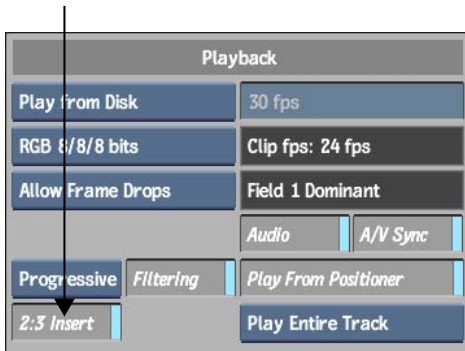

Outputting a Clip to Tape with 2:3 Pulldown Insertion

To output a 24p master to tape in the 60i format from which the material originated, enable 2:3 insertion on output.

To output a 24p clip with 2:3 insertion:

- 1 Follow the general procedure for outputting a clip, and stop before you click the Process button. See [Outputting Clips To a VTR](#) on page 153.
- 2 Click the Eng button.

The Engineering menu appears.

VTR : DigiBeta NTSC	Timecode VITC & LTC	PreRoll 150	PostRoll 30	01:00:19:12	Tape EE	Standby	
Ntsc	In Serial 1 4:2:2	Video Input Delay 0			2:3 Insertion		24->DF Ref 00:00:00:00
10-bit Precision	Out Serial 4:2:2	Video Output Delay 0	Stop VTR On EXIT	AA* 00:00:00:00	Paused	YCbCr->RGB	Edit-Sync Creation
	YCbCr->RGB	Audio Input Delay 0.00	Cue Up VTR	CCIRG01 525(10-bit prec.)		48000 EMB	Monitor VTR
Audio Preferences	House	Audio Output Delay 0.00	Error Retry 10				

(a) AA Reference field (b) 24>DF Reference field

- 3 Enable 2:3 Insertion.
- 4 In the AA Reference field, enter a timecode on the tape that corresponds to an AA frame.
- 5 If the tape is drop frame, in the 24>DF Reference field, enter the drop frame reference timecode.

If you output a 24 fps clip to a drop frame tape, and you want to output to the same spot on the tape, use the same reference timecode that was used when you input the clip. The Drop Frame Reference Timecode field is used to calculate the correct in point on the drop frame tape. When you set the reference timecode in this field, note that the in point timecode field is updated accordingly.

- 6 Return to the Output Clip menu and set the In and Out timecodes. When outputting with 2:3 insertion, the Duration field is automatically adjusted to display the total number of frames after insertion.

In and out 2:3 pulldown frames appear when 2:3 Insertion is enabled in the Engineering menu. They indicate which type of inserted frame falls at the specified in- and out-timecode. When outputting clips:

- The in point can occur at any 2:3 pulldown frame except D/D.
- The out point can occur at any 2:3 pulldown frame except B/C.

This ensures the integrity of the output material on the tape.

- 7 Continue the procedure for outputting a clip.
The new clip is outputted to tape with 2:3 pulldown insertion.

Exporting EDLs with 2:3 Pulldown Insertion

You can export an EDL for a 24p clip that converts the 23.97 fps information to 29.97 fps information and maintains 2:3 pulldown information for all in and out points (including cuts, wipes, dissolves and timewarps). 2:3 pulldown information is important when master tapes are to be sent out for hardware-based tape-to-tape colour correction.

When exporting the EDL, the 2:3 Insertion Mode button must be enabled. It is enabled by default when a 24p template is selected at project creation.

To export an EDL with 2:3 pulldown:

- 1 Follow the general procedure for exporting an EDL, and stop at the point where you specify EDL Save options. See [Generating EDLs](#) on page 399.
- 2 In the EDL Save Options group, enable 2:3 Insertion Mode.

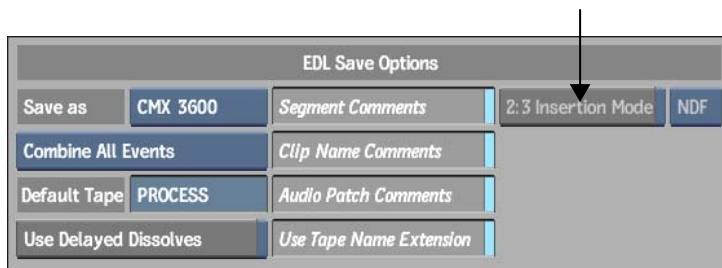

- 3 Continue the procedure for exporting an EDL.
The new EDL is generated with 2:3 pulldown information inserted.

Topics in this chapter:

- [About Interlaced Video](#) on page 719
- [Accessing the Video Menu](#) on page 720
- [Managing Field Dominance](#) on page 720
- [Deinterlacing and Interlacing Clips](#) on page 725
- [Merging Fields](#) on page 727

About Interlaced Video

Interlaced video formats divide frames into two line-based fields. One field consists of the first and subsequent odd lines in the frame, and the other field consists of the second and subsequent even lines in the frame. During the recording process, the two fields are recorded at slightly different moments. For example, when recording NTSC using field 1 dominance, field 1 is recorded 1/60th of a second before field 2.

As a result, video frames can betray the slight time difference between fields with jitter, particularly when they contain fast motion. When broadcast, the fields are displayed on-screen with the corresponding temporal offset. Interlaced video broadcasting is, from the human perceptual perspective, relatively seamless.

Not all interlaced video formats interlace frames in the same way. If you need to mix different interlaced video formats, you may need to change the field

dominance of your clips. To work with field-based clips in Flame, use video field management tools to make sure results do not introduce interlacing artefacts or field-dominance jitter.

By default, when you edit or composite clips that have conflicting scan formats, Flame displays warning messages and requires you to confirm potentially problematic operations. If you are comfortable working with clips that have different scan formats, you can disable these warnings by enabling Ignore Scan Format in the Modules section of the General Preferences menu. See [General Preferences](#) on page 836.

Accessing the Video Menu

Most video field management commands appear on the desktop in the Format menu. To access the Format menu, click Format in the Main menu.

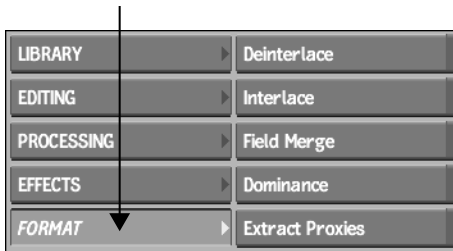

You can also access these commands in Batch.

Managing Field Dominance

Other than a few non-standard exceptions, all interlaced video formats are field 1 dominant. This means that for a given frame, field 1 (F1) is recorded earlier in time, and therefore should be displayed first during broadcast. Field 2 (F2) is recorded after F1 and is therefore displayed after F1 during broadcast.

Where interlaced video formats differ, however, is in the first active line. The first active line is the uppermost line in the frame: in some interlaced video formats, this uppermost line belongs to F1; in others, it belongs to F2.

Format:	First active line belongs to:
NTSC	F2
PAL	F1

Format:	First active line belongs to:
HD (interlaced)	F1

With mixed-resolution projects, you can mix interlaced video formats that have different first active line properties. However, you must account for the differences between the two formats. Otherwise, you risk outputting a result that displays one of the interlaced video formats improperly—introducing noticeable jitter as the field that was recorded earlier in time is displayed after the field that was recorded later in time.

You can mix clips with differing interlaced video formats in a project by reversing the field dominance of clips that do not correspond with your project's default resolution interlacing properties. For example, if you bring a PAL clip into an NTSC project whose material is F2 dominant, you should reverse the field dominance of the PAL clip.

When working with clips that have conflicting field dominance, you can:

- Change the scan mode of the project for the current session. Use this procedure to preview material with incorrect field dominance.
- Reverse the field dominance of a clip so it matches the rest of your material. Use this procedure, for example, to allow an F1 PAL clip to mix properly with an F2 NTSC clip.

NOTE The effects of both these procedures are only apparent on an interlaced broadcast monitor.

All clips in Flame have a metadata tag for scan mode. This tag is assigned when the material is first brought in. If the tag scan mode is incorrect, you can change it to match the actual scan mode of the clip.

Changing the Scan Mode of a Project

The project scan mode dictates how interlaced video formats are captured from tape, sent to the broadcast monitor in-session, and output to tape. The project scan mode also determines field-based processing.

You can change the scan mode of your project by selecting an alternative scan mode option. Do this, for example, to view a PAL clip in an NTSC project properly before reversing its field dominance. Generally, changing the scan mode of a project is a temporary measure performed only to allow for the

monitoring of clips whose format does not match the scan mode of the current project.

To change the scan mode of a project:

- 1 In the Project Management section of the Preferences menu, click the project Edit button.



- 2 From the Scan Mode box, select Field 1 or Field 2.

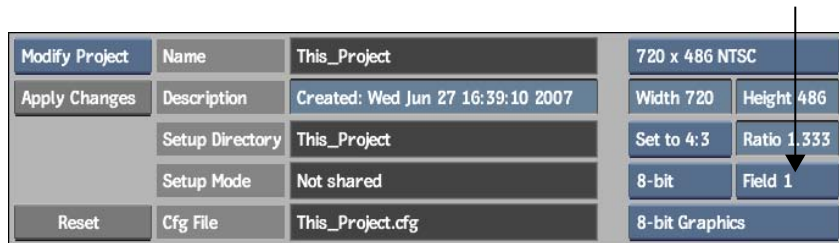

- 3 Confirm that Modify Project is selected in the Project Edit box, click Apply Changes, and then Confirm.

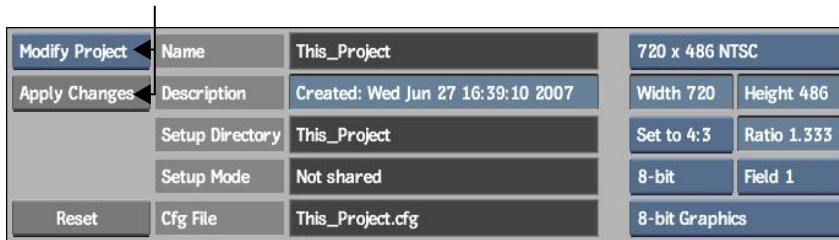

NOTE The effects of switching the scan mode of a project between field 1 and field 2 are only visible on an interlaced broadcast monitor (which accounts for the slight flicker when you pause on an interlaced video frame). The graphics monitor displays both fields at the same time.

Reversing Field Dominance

When working in a project that uses clips originating from different interlaced video formats, you may have to reverse the field dominance of clips that do not correspond with the project's interlacing properties.

You can reverse the dominance of clips on the Desktop using the Dominance command in the Format menu. When you do so, the first and last fields of the clip are dropped to account for the offsetting required to reverse the field dominance: the result clip is one frame shorter. It is a good idea to capture enough head and tail frames so that the fields dropped on both ends do not affect the frames you want to use.

Both the media and the scan mode metadata tag are changed by this process.

To reverse the dominance of clips:

- 1 In the Format menu, click Dominance.

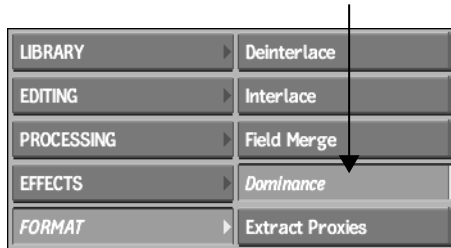

- 2 From the Scan Mode Tools box, select Reverse Dominance.

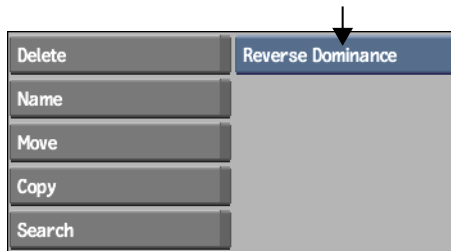

- 3 Select the clip to which you want to apply the process.
- 4 Select the destination reel.
The field dominance of the clip is reversed.

Changing the Scan Mode Metadata Tag of a Clip

When material is brought into Flame, it is assigned a particular scan mode that becomes part of the clip metadata. When you view clip information, the scan mode displayed is from the clip metadata tag. The scan mode metadata tag for a clip may be wrong, for example, if you specified the scan mode as being field 1 when importing it, and it was actually field 2.

You can correct this problem using the Change Dominance option of the Dominance tool in the Video menu. This option changes the scan mode metadata tag for a clip without changing the actual scan mode of the media on the framestore.

To change the scan mode metadata tag for a clip:

- 1 In the Format menu, click Dominance.

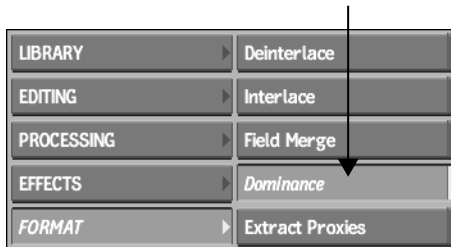

- 2 From the Scan Mode Tools box, select Change Scan Mode.

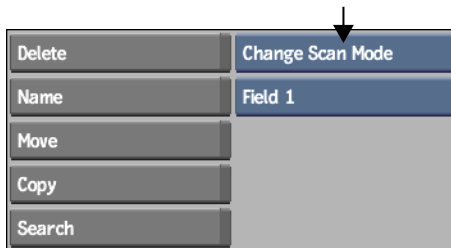

- 3 From the Scan Mode box, select the scan mode metadata tag that you want to assign to the clip.
- 4 Select the source clip.
- 5 Specify the destination.
A new clip with the specified metadata tag is processed.

You can also do this from the clip library Tools menu.

To change the scan mode metadata tag for clips from the clip library Tools menu:

- 1 Select a single clip or hold **Ctrl** and select multiple clips in the clip library.
- 2 Click Tools.



- 3 From the Tools menu that appears, choose Dominance. The Change Dominance controls appear.

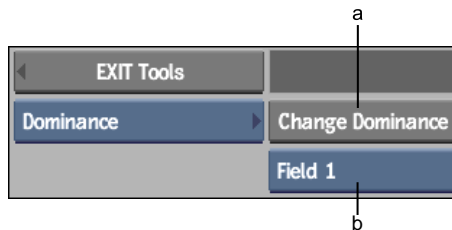

(a) Change Dominance button (b) Scan Mode box

- 4 From the Scan Mode box, select the scan mode metadata tag that you want to assign to the selected clips.
- 5 Click Change Dominance and confirm the operation. The scan mode metadata tag of the selected clips is changed.

Deinterlacing and Interlacing Clips

Deinterlacing and interlacing are used primarily to aid in the rotoscoping of field-based material, or in the application of filters to field-based material. Deinterlacing and interlacing are not necessary for processes that support field-based rendering.

Because there is a line-based difference in time per frame of interlaced video, if you paint or filter field-based frames, artefacts can be introduced. For example, if you blur over fields, colour information from pixels on the F1 field is smudged into the pixels on the F2 field.

Deinterlacing clips prior to painting or filtering separates each field, allowing you to work on separate fields and achieve better results. Once the effects have been added, re-interlace the clip.

Deinterlacing Clips

Deinterlace clips to separate each field to its own frame. The result clip is twice as long as the original.

To deinterlace clips:

- 1 In the Format menu, click Deinterlace.
- 2 If necessary, select Field 1 or Field 2 from the Field Dominance box. By default, Field Dominance is set to Auto, which automatically determines whether the clip is Field 1 or 2 dominant. The other settings are available if Auto does not return the desired result.



- 3 From the Interpolation box, turn Interpolation on or off.

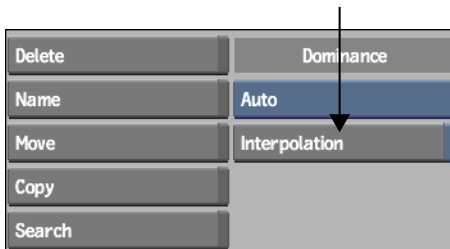

- If you deinterlace clips with interpolation off, the process repeats each isolated line to fill in the scan lines that would otherwise be vacant in the resulting clip's frames.

- If you deinterlace clips with interpolation on, the process interpolates a blend between adjacent lines to fill in the isolated scan lines. This option reduces interlacing artifacts.
- 4 Select the clip that you want to deinterlace.
 - 5 Select the destination reel.
The result clip—twice as long as the original clip—appears.

Interlacing Clips

Interlace clips to restore deinterlaced fields to interlaced frames. The result clip is half as long as the original.

To interlace clips:

- 1 In the Format menu, click Interlace.
- 2 From the Field Dominance box, select Field 1 or Field 2.



- 3 Select the clip that you want to interlace.
- 4 Select the destination reel.
The result clip—half as long as the original clip—appears.

Merging Fields

Merging fields blends pixels in neighbouring field lines to reduce artefacts caused by motion jitter. Merge fields when you have interlaced material that you want to output to a progressive scan format.

To merge fields:

- 1 In the Format menu, click Field Merge.
- 2 Enter the percentage of blending between fields in the Level field.

LIBRARY	Deinterlace	Remove Pulldown	Separate	Delete	Level 100%
EDITING	Interlace	Add Pulldown	Combine	Name	
PROCESSING	Field Merge	Burn In	Interleave	Move	
EFFECTS	Dominance	Change TC / KC / Rate	Deal	Copy	
FORMAT	Extract Proxies	Regenerate Proxies	Resize	LUT	Search

Value	Result
100%	The average pixel value is replicated to both fields in an F1/F2 merge-pair, resulting in total field merging.
50%	Pixels on each line in an F1/F2 merge-pair are replaced by pixels defined by 50% of their original value and 50% of the blend, or field merge result.
0%	No change is applied to the clip.

- 3 Select the clip that you want to process.
- 4 Select the destination reel.
After a short time, the result clip appears.

Colour Management with LUTs

29

Topics in this chapter:

- [About Colour Management](#) on page 729
- [General Workflow for LUTs](#) on page 732
- [Workflow for Custom 1D LUTs](#) on page 733
- [Using LUTs Created Outside of Flame](#) on page 733
- [Viewing Clips with 3D LUTs](#) on page 738
- [Processing Clips with 3D LUTs](#) on page 742
- [Applying a LUT on Import or Export](#) on page 744
- [Accessing the LUT Editor](#) on page 745
- [Creating Custom 1D LUTs](#) on page 749
- [Saving LUT Editor Setups](#) on page 766
- [Loading LUT Editor Setups](#) on page 767
- [Exporting LUTs](#) on page 768
- [Converting OpenEXR Images](#) on page 770

About Colour Management

Digitized film images originating from a datacine conversion process are high-resolution scans that preserve much of a film's resolution and colour depth.

In Flame, a lookup table (LUT) is the primary colour management tool available to deal with different colour spaces. A LUT is an ASCII file used to map pixels or pixel components from one colour to another. To display logarithmic film scans properly, such as Cineon files in the linear colour space native to Flame, you can work with monitor, display, and image conversion LUTs. You can use one of two kinds of LUTs: 1D LUTs and 3D LUTs.

Digital film scans often consist of logarithmic data rather than linear data. Linear data maps the luma range in equal intervals from black to white. Logarithmic data allows for more subtlety in the lower luma ranges of an image. In Flame, you can work with either logarithmic or linear data.

When you want to work with linear data, you can use an image conversion LUT on input to convert the logarithmic data to linear data. Since Flame assumes that input data is linear, it behaves more predictably when you work with linear data than when you work with logarithmic data.

When you want to preserve the image data contained in logarithmic film scans and do not want to apply an image conversion LUT, you can work directly with logarithmic clips. Working with logarithmic clips prevents any data loss that could occur during the image conversion process. When you work with logarithmic clips, however, apply a LUT for display purposes. Display LUTs affect transient data only — no data conversion is committed to the clip.

1D LUTs

A 1D LUT is generated from one measure of gamma (white, grey, and black) or a series of progressive measures for each colour channel. 1D LUTs are created and edited in Flame and other applications. They are used as image conversion LUTs when you import and export clips and as monitor LUTs. Monitor LUTs ensure the image seen on the monitor resembles the final output without modifying the image data. Image conversion LUTs are typically used to convert between the logarithmic data contained in film scans and the linear data used in Flame. The procedures in this chapter describe how to use image conversion LUTs.

You can apply an image conversion LUT when importing a logarithmic film scan, and then apply the inverse LUT to convert the image data back to log data when exporting the final output. For example, you can use an import LUT to convert 10-bit logarithmic film images to 8-, 10-, or 12-bit linear images for manipulation in Flame. When you finish modifying the image and ready to export it, you can apply the inverse LUT to restore the 10-bit logarithmic data, ensuring that the modified film print matches the original shot.

Flame provides some ways to work with image conversion LUTs. You can use the predefined LUTs, which are the simplest mechanisms for file conversion. You can create customized LUTs that meet your needs more precisely. You can also use a 1D LUT created outside of Flame as long as it matches the LUT format that Flame uses. In most cases, you want to modify the LUT to maximize the range of data used. Because you are fitting 10-bit log data into 12-bit linear data, select the range in an image which produces the most accurate results with minimal loss of precision. The following illustration shows the histogram of a 10-bit logarithmic image with a modified LUT curve that produces the accurate results.

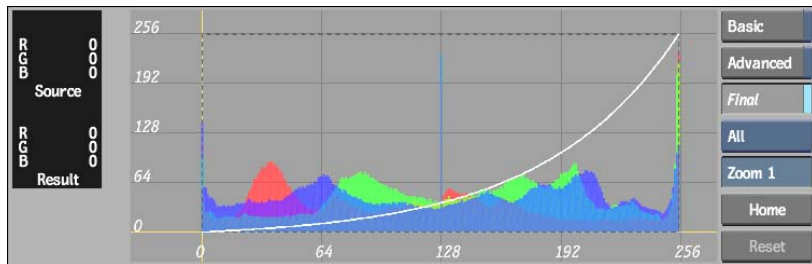

Monitor LUTs affect the way images display on the monitor without altering the underlying image data. If you import logarithmic film scans without conversion, you can use a monitor LUT (or a 3D LUT) to display the images correctly. Even when you apply an image conversion LUT to film scans on import, you still require a monitor LUT to reproduce the gamma qualities of film.

3D LUTs

3D LUTs are used for advanced film colour management in Flame and provide a superior alternative to 1D LUTs. 3D LUTs are primarily used for display purposes and are the most accurate means of displaying logarithmic film scans on a graphics monitor. Since 3D LUTs often set up the proper display environment for your film clips, they are only applied to the Player or one or more viewers, rather than the entire monitor.

3D LUTs are always created outside of Flame, and they are uneditable once imported. Instead, you can work with outside hardware and software, such as the Kodak™ Display Management system, to generate a 3D LUT for your needs. While there are generic 3D LUTs that are interchangeable between different systems, these generally provide less accurate results since they can only approximate the current viewing conditions.

3D LUTs place higher processing demands on your system than 1D LUTs. As such, interaction speed can slow down. To offset these demands and view clips in real time, you can process them with the 3D LUT.

If you are outputting footage destined for film, but require an intermediate video version, you can also process clips with 3D LUTs. You can process the footage with a 3D LUT, committing the log-to-linear data conversion to a video clip that will be viewed at another location. While this process produces footage with the closest accuracy to film look, its accuracy cannot match how the clip appears on your calibrated Flame system. You cannot use a 3D LUT to convert linear data back to log data.

Clips are processed with 3D LUTs on the desktop using the LUT module (accessible from the Format menu) or in the LUT Editor when accessed from the following nodes in Batch: LUT Editor, Import, Export, Segment FX, and Output nodes. They are not processed when importing or exporting from the desktop.

General Workflow for LUTs

The following table shows the workflow when working with a LUT that has already been created, whether it is a 1D or 3D LUT.

NOTE Flame includes some predefined 1D LUTs.

Depending on whether you are using 1D or 3D LUTs, whether you are processing your clips with the LUTs or just using them for viewing purposes, you perform one or more of the following steps.

Step:	Refer to:
1. Import a 1D LUT or 3D LUT created in an outside application.	Using LUTs Created Outside of Flame on page 733
2. In Flame, you can apply a 3D LUT to the Player or to a viewport, for viewing purposes.	One of the following: <ul style="list-style-type: none">■ Applying 3D LUTs to the Player on page 738■ Applying 3D LUTs to the Image Window on page 739
3. Process clips with 1D LUTs on import or export.	Applying a LUT on Import or Export on page 744

Step:	Refer to:
4. Process clips with 1D or 3D LUTs from the LUT Editor accessed from the Desktop or in Batch.	One of the following: <ul style="list-style-type: none"> ■ Accessing the LUT Editor on page 745 ■ Accessing the LUT Editor in Batch on page 748 ■ Processing Clips with 3D LUTs on page 742

Workflow for Custom 1D LUTs

The following table shows the workflow for creating a custom LUT.

Step:	Refer to:
1. Open the LUT Editor.	Accessing the LUT Editor on page 745
2. Select a basic conversion LUT type.	Defining a Basic LUT Type on page 752
3. Change the basic conversion curve.	Modifying Basic Conversion LUT Curves on page 754
4. Fine-tune the final conversion LUT.	Advanced Editing of the Conversion LUT Curve on page 762
5. Use colour patches to sample and compare corresponding colours in the source, reference, and result clips.	Comparing Colour Values Using Colour Patches on page 765
6. Save your work: <ul style="list-style-type: none"> ■ Save the LUT Editor setup to preserve its settings. ■ Export the LUT to modify its bit depth or create a new basic LUT type. 	Saving LUT Editor Setups on page 766 or Exporting LUTs on page 768

Using LUTs Created Outside of Flame

Although Flame provides a LUT Editor for creating 1D LUTs interactively, you can use 1D LUTs created outside the Flame environment. You can also use 3D LUTs, which are always created outside Flame.

To recognize LUTs, the 1D or 3D LUT file must follow the correct format, have the correct name, and be in the correct directory location. Comment lines are permitted.

Configuring Flame to Use 1D LUTs

You can use LUTs created in other Autodesk applications, such as Combustion, as well as share LUTs between Autodesk Visual Effects and Finishing products. You can also use LUTs created in third-party applications as long as they are in the recognized format.

All 1D LUT files must have the *.lut* extension.

Save all LUTs in the project LUT directory, *~/lut* by default, for ease of use, and so that the project archives the LUTs with the project setups.

You can access LUTs from anywhere on your network using the file browser. This can be useful if you are sharing the same LUT between multiple applications.

1D LUT Format

The LUT file begins with a declaration of the number of tables and the number of entries per table:

```
LUT: <number of tables> <number of entries per table>
```

The number of tables in the file depends on the channel-resolution required. For a LUT in which all three RGB channels are converted using the same values, just one table is required. To convert the three channels using different values, use three tables. For three channels plus alpha, use four tables. The number of entries in each table corresponds to the bit depth of the source file: 256 entries for 8-bit resolution, 1024 for 10-bit and 4096 for 12-bit. For example, a LUT operating on three 8-bit channels independently would have the following declaration:

```
LUT: 3 256
```

Each line following the header contains a single entry indicating the value to which the source is converted. For example, a table converting 10-bit logarithmic values to 8-bit linear would contain 1024 entries, corresponding to the 0-1023 intensity range of pixels in the source file. Each of these entries would be in the range of 0-255, corresponding to the intensity range in the

destination. The following table shows the first and last few entries for a sample LUT of this type.

Entry	Value	Meaning
0	0	10-bit 0 is converted to 8-bit 0
1	0	10-bit 1 is converted to 8-bit 0
2	0	10-bit 2 is converted to 8-bit 0
3	1	10-bit 3 is converted to 8-bit 1
4	1	10-bit 4 is converted to 8-bit 1
5	2	10-bit 5 is converted to 8-bit 2
6	2	10-bit 6 is converted to 8-bit 2
...		
1021	255	10-bit 1021 is converted to 8-bit 255
1022	255	10-bit 1022 is converted to 8-bit 255
1023	255	10-bit 1023 is converted to 8-bit 255

Blank lines and comment lines (starting with a number sign [#]) are ignored by Flame. Comment lines are useful in indicating the end of one table and the beginning of another, or for describing how your script or program works.

Configuring Flame to Use 3D LUTs

After you perform basic monitor calibration and take calibration measurements using the appropriate calibration device, you can work with your film lab to generate a 3D LUT file to account for both the characteristics of the monitor and the characteristics of the film stock you are using. Ideally, 3D LUTs should be developed for a particular monitor and a particular film stock.

All standard 3D LUT files must have the *.3dl* extension; encrypted 3D LUTs must have the *.e3dl* extension. Encrypted 3D LUTs can be created using the Kodak Display Management system and can only be used on the system on which they were created.

You can share 3D LUTs between Autodesk Visual Effects and Finishing products. You can use 3D LUTs from Lustre that have the *.3dl* extension. You can also use LUTs created in third-party applications as long as they are in the recognized format.

For ease of use, it is recommended that you save all 3D LUTs in the project's LUT directory, called *~/lut* by default. In this case, they will be archived with the setups of the project.

To have Flame recognize particular 3D LUTs at start-up, you must import them into the 3D LUT list. See [LUT Preferences](#) on page 861.

You can access 3D LUTs for the 3D LUT list from anywhere on your network using the file browser. This can be useful if you are sharing 3D LUTs between multiple applications.

You want Flame to recognize these 3D LUTs for the following reasons:

- So the 3D LUT is accessible from the 3D LUT box in the Player menu for viewing purposes. See [Applying 3D LUTs to the Player](#) on page 738.
- So the 3D LUT is accessible from the Reference Buffer box in the View menu to apply to the frames displayed in the reference buffer overlay. See [Applying 3D LUTs to the Reference Area and Overlay](#) on page 741.
- So the 3D LUT can be applied to a viewport. See [Applying 3D LUTs to the Image Window](#) on page 739.

3D LUT Format

A 3D LUT represents a colour conversion from one colour space to another. It applies a transformation on each value of a colour cube in RGB space. However, 3D LUTs use a more sophisticated method of mapping colour values between different colour spaces than 1D LUTs. Where 1D LUTs represent a transformation in which each colour channel (red, blue, and green) is independently mapped, 3D LUTs represent a transformation in which each colour channel is affected by the other two channels. For example, a highly saturated blue on film will also have an effect on the red and green channels, which 3D LUTs take into account. 3D LUTs can take into account the characteristics of both your monitor and the film stock you are using.

A colour cube can be subdivided into any number of vertices ($N \times N \times N$), where each vertex corresponds to an RGB value. You can apply a 3D translation to any of these values (dR,dG,dB) to map equivalent colours between colour spaces. Each RGB value, then, would have an equivalent transformed RGB value (R',G',B'). A 3D LUT maps these equivalents.

The first line of a 3D LUT file determines the level of segmentation of the colour cube, which determines how many vertices there are to assign values to. While each colour channel could be segmented differently, Flame support a uniform RGB segmentation of 17. The first line of the 3D LUT indicates at what 17 intervals input and output values are matched. All RGB values are represented in the 10-bit colour space. So, the first line of a 3D LUT indicates the 17 sampling intervals in the 10-bit space:

**0 64 128 192 256 320 384 448 512 576 640 704 768 832
896 960 1023**

The RGB colour cube, then, is divided by 17 vertices on each of the R G and B axes corresponding to these values, resulting in 17x17x17 RGB values. This is the same number and ratio of vertices that are output in the 3D LUT files created by the Kodak Display Manager.

The 3D LUT file then lists transformed RGB colour output values for each input colour value.

The 3D LUT list assigns a colour value for every vertex. The RGB values on the first line in the list are for (0,0,0), those on the second line are for (0,0,1), and those on the third line are for (0,0,2). Values for the blue index are incremented first, followed by the green index, followed by the red index, until the whole list of 17x17x17 is complete.

The vertex ordering is represented by the following:

0,0,0
0,0,1
0,0,2
...
0,0,16
0,1,0
0,1,1
0,1,2
...
0,1,16
0,2,0
0,2,1
...

...
0,16,16
1,0,0
...
...
16,16,16

For example, suppose the third line of the vertex list in a 3D LUT file is:

12 30 141

The third line in the list corresponds to the vertex in the 3D colour cube at the following coordinates: (0,0,2). Using the 17x17x17 subdivided colour cube, and the intervals indicated in the first line of the file, these coordinates correspond to the input colour (R=0, G=0, B=128).

That means that the input colour (0,0,128) will be mapped to the output colour (12,30,141).

Since most input colour values fall between the RGB values corresponding to the 17 sampling intervals, output colour values often result from an interpolation between the surrounding vertices.

Viewing Clips with 3D LUTs

You can use 3D LUTs to accurately display film clips on the graphics monitor. 3D LUTs are applied to the Player and image window, rather than to the entire monitor.

By default, the graphics monitor (and therefore the Player and image window) displays images using the default LUT defined in the 3D LUT list.

However, if you have also configured Flame to detect one or more 3D LUTs, you can toggle the Player and image window to use 3D LUT display mode instead. The clip itself is not affected: the 3D LUT only affects the display.

To configure Flame to use 3D LUTs, see [Configuring Flame to Use 3D LUTs](#) on page 735.

Applying 3D LUTs to the Player

In the Player, you can switch to 3D LUT display mode, and then select the 3D LUT you want to use to accurately display film clips.

To apply a 3D LUT to a clip in the Player:

- 1 Click the Clip & Setup tab.
- 2 Enable 3D LUT or press **Ctrl+Shift+~**.

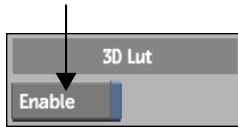

NOTE If the 3D LUT button is inactive, you have not configured the 3D LUT list. See [LUT Preferences](#) on page 861.

The 3D LUT box appears, indicating which 3D LUT is currently being applied to the Player.

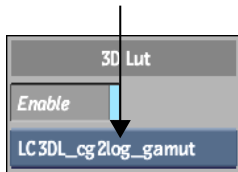

- 3 To change 3D LUTs, do one of the following:
 - Select the 3D LUT that you want to apply from the 3D LUT box.
 - Select the 3D LUT that you want to apply by pressing its corresponding hot key **Ctrl+Shift+(1-0)**.
- 4 To turn off 3D LUT processing, disable 3D LUT or press **Ctrl+Shift+~**.

Applying 3D LUTs to the Image Window

To accurately display film clips, you can apply 3D LUTs to the image window, including the reference area and the reference overlay.

3D LUT display in the image window is only supported in modules that also support multiple viewports: Resize, the Colour Corrector (including the Colour Warper), the Modular Keyer, Distort, Batch, and Action. See [Previewing Results for Processing Commands](#) on page 1427 and [Previewing Results for Format Commands](#) on page 1446.

When you are working with multiple viewports, you can apply different 3D LUTs to each viewport independently.

To apply a 3D LUT to a clip in the image window:

- 1 With a clip in the current viewport set to Front, Back, or Result view, enable Use 3D LUT (**Ctrl+Shift+~**) to enable 3D LUT display mode. The 3D LUT displayed in the 3D LUT list is applied by default to the viewport. Its name appears in the lower-right corner of the viewport.

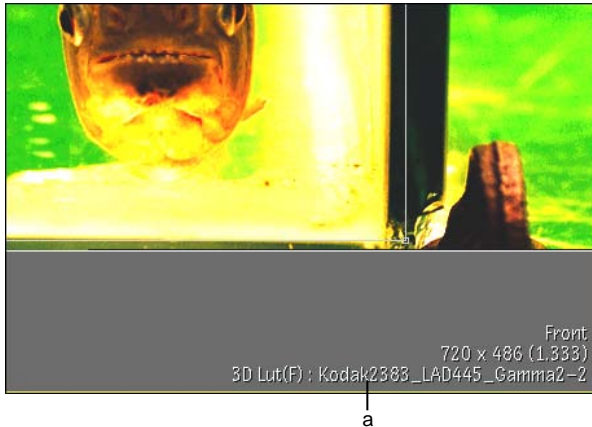

(a) 3D LUT name in the viewport

Image courtesy of Technicolor (formerly Toybox)

- 2 To change 3D LUTs, do one of the following:
 - In the View menu, select the 3D LUT from the list in the Current Viewport box.

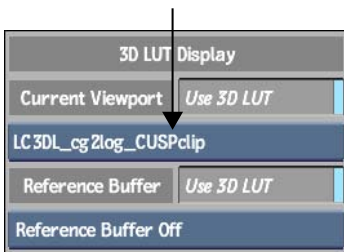

- Use hot keys to switch between 3D LUTs defined in the 3D LUT list.

Press:	To apply:
Ctrl+Shift+1	The first 3D LUT defined in the 3D LUT list.

Press:	To apply:
Ctrl+Shift+[2-9]	The second through ninth 3D LUT defined in the 3D LUT list.
Ctrl+Shift+0	The tenth 3D LUT defined in the 3D LUT list.

- To toggle the current 3D LUT on and off, press its associated hot key (**Ctrl+Shift+[1-0]**).
When the 3D LUT is on, its name is in light blue. When it is off, its name is in black.
- To disable 3D LUT display mode, press **Ctrl+Shift+~**.

Applying 3D LUTs to the Reference Area and Overlay

You can enable 3D LUT display mode, and then apply 3D LUTs to the frames displayed when using the reference overlay.

To apply 3D LUTs to the reference overlay:

- In the View menu, enable Split Bar to display the overlay in the viewport.
- Enable Use 3D LUT display mode for the reference buffer.
- Select a LUT from the 3D LUT List box.

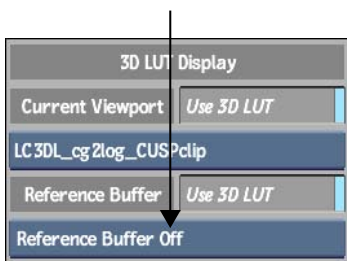

- To disable 3D LUT display mode for the reference overlay, select Reference Buffer Off option.

Working with Multiple Views and 3D LUTs

When you are working in a module that supports multiple views, you can apply different 3D LUTs to each viewport independently.

To apply 3D LUTs when working with multiple viewports:

- 1 Click a viewport to make it current.
- 2 Press **Ctrl+Shift+~** to enable 3D LUT processing.
The name of the current 3D LUT appears in the lower-right corner of the current viewport.

NOTE In cases where a viewport is small, there may not be enough room to display the 3D LUT's name.

- 3 Click another viewport to make it current (a yellow border indicates the current viewport).
- 4 Select a 3D LUT from the Viewport box, or press **Ctrl+Shift+[1-0]** to enable the corresponding 3D LUT in the 3D LUT list.

Processing Clips with 3D LUTs

You can process clips with a 3D LUT to commit the colour conversion to the clip. There is no way to restore logarithmic data once you have processed a clip with a 3D LUT. Typically, you do this to release a film clip for review on video, or to guarantee real-time playback which may not be possible in 3D LUT display mode.

While this process produces footage with the closest accuracy to film look, its accuracy cannot match how the clip appears on your calibrated Flame system. Furthermore, you cannot use a 3D LUT to convert linear data back to logarithmic data.

You import a 3D LUT to process clips using the LUT Editor when it is accessed from the Desktop or Batch. The LUT Editor is accessible from Batch clips and the following nodes in Batch: LUT Editor, Import, Export, Library, Batch FX Output, and Output.

To process a clip with a 3D LUT:

- 1 Do one of the following:
 - Access the LUT Editor in Batch from a Batch clip or a LUT Editor, Import, Export, Library, or Output node. See [Accessing the LUT Editor in Batch](#) on page 748.
 - Access the LUT Editor from the desktop. See [Accessing the LUT Editor](#) on page 745.

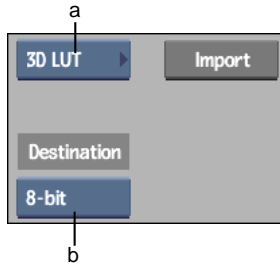

(a) Conversion LUT Type box (b) Destination box

- 2 From the Conversion LUT Type box, select 3D LUT.
- 3 Click Import LUT.
The file browser appears.
- 4 Navigate to the 3D LUT file you want to use, select it, then click Load.
You return to the LUT Editor, and the 3D LUT is applied to the clip in the image window. The 3D LUT name appears in the field next to the Import LUT button.
- 5 Select an output bit-depth option from the Destination box.

Select:	To:
8-bit	Output 8 bits per channel.
10-bit	Output 10 bits per channel.
12-bit	Output 12 bits per channel.
12-bit Unpacked	Output 12 bits per channel, unpacked.
16-bit float	Output 16 bits per channel, floating point data.

- 6 Click Process.
The clip is processed with the 3D LUT to the destination you selected.

Applying a LUT on Import or Export

Applying a LUT to a film clip on import or export converts the clip's images according to the contents of the LUT. You can only apply 1D LUTs on import or export.

A typical workflow when using 1D LUTs would be to apply the **10logto12** import LUT provided, converting 10-bit logarithmic image data to 12-bit linear image data. After working with the images in Flame, you would then export the clip using the inverse of the LUT, **12to10log**. This restores its logarithmic values, in preparation for film printing.

Sample 1D LUTs have been provided that cover the most common conversion processes, and use standard data for Cineon digital negatives (normal exposure). If these LUTs do not give the desired results, you can use them to create a custom LUT. Often, a minor adjustment is all that is required. See [Creating Custom 1D LUTs](#) on page 749.

NOTE You can create custom LUTs using the Import Image menu. You cannot create custom LUTs when exporting from the desktop—you must use an existing LUT. You can create a custom LUT when exporting using the LUT Editor. You must export the clip from Batch using an Export node. See [Accessing the LUT Editor in Batch](#) on page 748.

To apply a LUT on image import or export from the Desktop:

- 1 In the Main menu, click Library.
- 2 In the Library menu, click Import Image or Export Image.
 - If you clicked Import Image, select a destination reel for the imported images.
 - If you clicked Export Image, select the clip that you want to export.
- 3 Enable Use LUT.

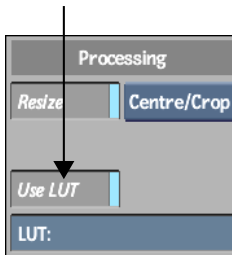

4 Click the LUT field.

The file browser appears. The Files list contains the LUTs currently residing in your project's `~/lut` directory. These include the samples provided with Flame, as well as any LUTs you may have saved or exported to this directory.

Sample 1D LUTs include the following.

LUT File Name	Conversion Process
10logto12	Converts a 10-bit logarithmic image to a 12-bit linear image.
10logto8	Converts a 10-bit logarithmic image to an 8-bit linear image.
8to10log	Converts an 8-bit linear image to a 10-bit logarithmic image.
12to10log	Converts a 12-bit linear image to a 10-bit logarithmic image.
invertRGB	Inverts the RGB values of the image.
oxberry12to8	Converts a 16-bit SGI image file created by the Oxberry film scanner to an 8-bit image file. Note that these SGI image files contain 12 bits of data scaled in a non-standard way.
oxberry12to12	Converts a 16-bit SGI image file created by the Oxberry film scanner to a 12-bit image file. Note that these SGI image files contain 12 bits of data scaled in a non-standard way.

5 Select a LUT in the Files list.

The Import Image or Export Image menu reappears. The LUT field displays the name of the new LUT. It will be applied to the clip you import or export.

Accessing the LUT Editor

Access the LUT Editor to create custom 1D LUTs or tailor existing ones.

You can access the LUT Editor from:

- The Desktop.
- The Import Image menu, by clicking Create LUT.

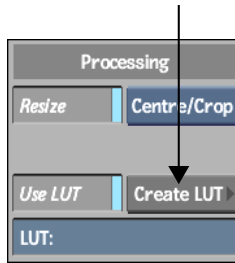

NOTE You cannot import 3D LUTs from the LUT Editor when it is accessed from the Import Image menu.

- The Batch schematic using a LUT Editor node, or from a Desk, Library, Export, Output, or Batch FX Output node via any one of these nodes' RGB LUT menus.
- The Batch clip via its RGB LUT menu.

You can also access the LUT Editor to process clips with 3D LUTs. See [Processing Clips with 3D LUTs](#) on page 742.

Once the LUT Editor is open, you can define a basic conversion LUT type—logarithmic to linear, vice versa, or custom. Or, you can use an existing LUT Editor setup as a starting point for creating the new LUT. A setup preserves certain useful menu settings.

To access the LUT Editor from the Desktop:

- 1 From the Format menu, click LUT.
- 2 Select a clip.
- 3 Select a destination reel.
The LUT Editor appears.
- 4 Click LUT Editor, select a clip, and then select the destination for the processed clip.
The LUT Editor appears, loaded with the current frame of the clip.
- 5 Define a basic LUT type, or load a LUT Editor setup to begin customizing the LUT. You can also load a 3D LUT with which to process the clip. See:
 - [Defining a Basic LUT Type](#) on page 752
 - [Saving LUT Editor Setups](#) on page 766

Accessing the LUT Editor from the Import Image Menu

Access the LUT Editor from the Import Image menu.

To access the LUT Editor from the Import Image menu:

- 1 In the Main menu, click Library.
- 2 In the Library menu, click Import Image.
- 3 Select a destination reel.
The Import Image menu appears.
- 4 Use the file browser to locate the image you want to import.
- 5 Enable Use LUT.
The LUT field and Create LUT buttons appear.

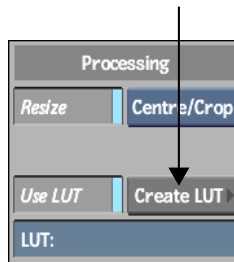

- 6 Click Create LUT.
- 7 Using the file browser, select a reference image.
When selecting a reference image, you load only a single frame (the first, by default). To select a different frame, switch to Proxies view mode and expand the image sequence by clicking on the proxy's expansion arrow.
The LUT Editor appears. When loading a large image, such as a 2K Cineon image, this can take a few moments.
- 8 Define a basic LUT type, or load a LUT Editor setup to begin customizing the LUT. See [Defining a Basic LUT Type](#) on page 752 and [Saving LUT Editor Setups](#) on page 766.

NOTE 3D LUTs cannot be accessed via the Import Image menu.

Accessing the LUT Editor in Batch

You can drag a LUT Editor node to the Batch desktop.

You can use the LUT Editor from any LUT Editor, Import, Output, Batch FX Output, or Export node to create or import a 1D LUT, or to import a 3D LUT. Clips are then processed through the LUT in the Batch process tree.

To access the LUT Editor using a LUT Editor node:

- 1 Drag a LUT Editor node to the Batch schematic.
- 2 Parent the output of another node to the front input socket of the LUT Editor node.



- 3 Select the LUT Editor node to view its menu.

To access the LUT Editor as an integrated part of clip input and output processes:

- 1 Select a Batch FX Output node or drag a Desk, Import, Output, or Export node to the Batch schematic.
- 2 Set up the node so the LUT you create is applied to the clip that you want to convert:
 - If you selected a Batch FX node or dragged a Desk node to the Batch schematic, you are ready to create the LUT or use the LUT Editor to import a 3D LUT.
 - If you dragged an Import node to the Batch schematic, use the file browser to locate the clip that you want to import.
 - If you dragged an Export or Output node to the Batch schematic, parent outputs from the process tree you are working on to the input socket(s) of the Export or Output nodes.

- 3 Select the clip.
- 4 Select the RGB LUT or Matte LUT menu.



TIP The Matte LUT menu appears in the Export node. You can create a LUT to remap luma for the alpha channel associated with the selected image on import, or remap the matte luma when exporting image formats that have an associated alpha channel.

- 5 Enable Active to apply the current LUT settings to the front clip.

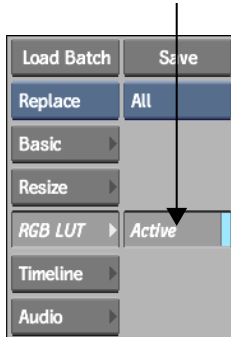

TIP The RGB LUT button in the Basic menu is linked to the Active button in the RGB LUT menu. Toggling either button enables the LUT.

Creating Custom ID LUTs

Because film prints vary greatly according to film stock, the sample 1D LUTs provided in Flame might not suit all needs. Similarly, because shooting can

occur under many conditions, the LUT you create to import one shot might not serve another, even within the same shoot or stock. With the LUT Editor, however, you can create a custom LUT.

Use the procedures in this section to create a custom LUT. When you create custom LUTs, the steps described in the custom 1D LUT workflow apply. See [Workflow for Custom 1D LUTs](#) on page 733.

Viewing Clips in the LUT Editor

Your view options depend on the location from which you access the LUT Editor. When accessed from the Import Image menu, you can view the current result and compare it with a reference clip.

When you access the LUT Editor from Batch, your view options are greater, based on the view options available to you in Batch. You can view the current result and compare it with a reference clip. You can also display the reference area to compare the results of one LUT Editor node with the results of another.

Viewing Clips in the LUT Editor in Batch

You can use the reference controls and the split bar to compare clips as you tweak the LUT in the LUT Editor in Batch.

For example, with a clip parented to a LUT Editor node in Batch, you can display the original clip under the split bar by selecting R:Front in the Reference box. This way, the applied LUT affects the result clip above the split bar, while the original clip is unaffected.

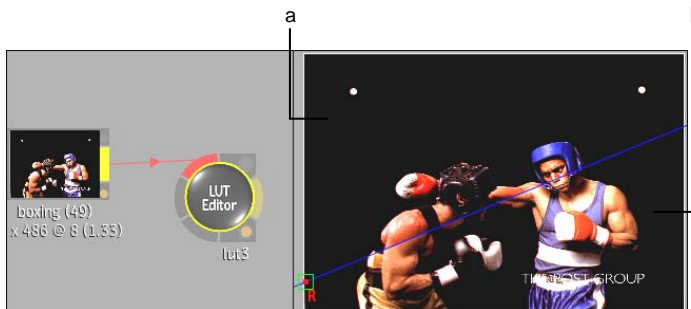

(a) Clip with LUT applied (b) Original clip without LUT

Image courtesy of The Post Group

You can set contexts to use as other reference clips or display reference frames stored in the buffer under the split bar. For more information on using references and the split bar, see [Displaying the Reference Area](#) on page 131.

You can also use multiple viewports in Batch to see the results of clips processed through different LUT Editor nodes. In addition to being able to use the LUT Editor's own reference controls, you can tweak the LUT parameters in different LUT Editor nodes to compare results. See [Displaying Multiple Views](#) on page 136.

To compare clips processed through different LUT Editor nodes:

- 1 In Batch, parent two clips to their own LUT Editor nodes.

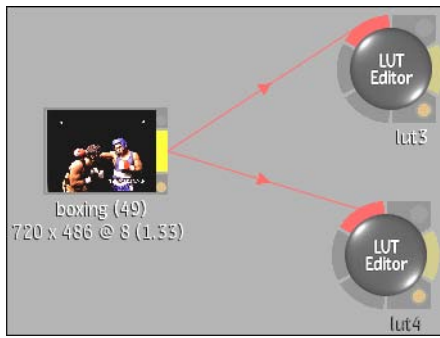

Image courtesy of The Post Group

- 2 Set one LUT Editor node as Context1 by selecting it and then clicking Set Context.
- 3 Set the other LUT Editor node as Context2 by selecting it and then clicking Set Context.
- 4 Press **Alt+3** to display the 3-Up view.
- 5 Arrange the three viewports to display the following views: Batch Schematic, Context1, and Context2.



Image courtesy of The Post Group

- 6 In the Batch schematic, double-click one of the LUT Editor nodes to display its menu, then adjust its properties.

The clip in the Context view corresponding to the LUT Editor node whose properties you adjusted is updated. You see your adjustments in relation to the clip affected by the other LUT Editor node.

NOTE While you can use this method to compare how clips will be processed by different 1D or 3D LUTs, if you are using 3D LUTs only for viewing purposes, just apply 3D LUTs to different viewports. This is possible only in the case of 3D LUTs since they can be applied per viewport. See [Applying 3D LUTs to the Image Window](#) on page 739.

- 7 If you want to see the original clip as a reference for the clips in the second and third viewport, do the following:
 - If necessary, enable Split Bar in the View menu.



- Select R:Front in the Reference box.

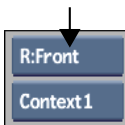

The split bar is displayed in both viewports containing the clips, with the original clip as a reference.

Defining a Basic LUT Type

One way to begin creating a custom LUT using the LUT Editor is by defining the type of LUT you want to use. You can choose from one of the presets for converting logarithmic data to linear data, linear to logarithmic, or for creating

a LUT to manipulate images that are already linear. Each of these selections sets up the appropriate conversion curve. It also includes selecting a bit-depth for the output. Alternatively, you can also choose to import a LUT as a starting point. Each of these techniques is discussed in this section.

Another way to create a custom LUT is to load a LUT Editor setup. See [Loading LUT Editor Setups](#) on page 767.

NOTE The procedures in this section do not apply to 3D LUTs.

To select a basic LUT type preset:

- 1 From the Conversion LUT Type box in the LUT Editor, select an option.



Select:	To:
Log to Lin	Begin with a standard curve for converting logarithmic data to linear data.
Lin to Log	Begin with a standard curve for converting linear data to logarithmic data.
Gamma	Begin with a standard curve for modifying linear data.
Import	Import a LUT to use its curve as a basic LUT. See the following procedure.
3D LUT	Import a 3D LUT. See Processing Clips with 3D LUTs on page 742.

The conversion curves for the basic LUT type you selected appear in the LUT Editor as the basic LUT.

- 2 Select an output bit-depth option from the Destination box. You can output 8 bits or 12 bits per channel.

Log to Lin	Ref White	170.748	170.748	170.748	Prop
	Ref Black	23.680	23.680	23.680	Prop
	Highlight	255.000	255.000	255.000	Prop
Destination	Shadow	0.000	0.000	0.000	Prop
8-bit	Custom	1.000	1.000	1.000	Prop
	Film Gamma	0.600	0.600	0.600	Prop
Export	Soft Clip	0.000	0.000	0.000	Prop

To import a LUT to use its curve as a basic LUT:

- 1 Select Import from the Conversion LUT Type box.



- 2 Click Import.
The file browser appears.
- 3 Locate and select the LUT that you want to import.

You are returned to the LUT Editor.

The LUT name appears in the field below the Import button. The imported LUT's conversion curves appear in the LUT Editor as the basic LUT.

NOTE When you import a LUT, advanced settings are merged into the basic settings. In order to access the settings used to create a LUT, you must load the LUT, not import it. See [Loading LUT Editor Setups](#) on page 767.

Modifying Basic Conversion LUT Curves

Once you define a basic LUT type, you can modify:

- The reference white and reference black values
- The highlights and shadows
- The gamma of the conversion curve

- The gamma of the incoming film negative
- The degree to which the shoulder at the upper end of the conversion curve is softened

When you modify these values, the basic LUT curves are updated to reflect the changes. For all procedures, you can monitor the R, G, and B channels independently while modifying the LUT.

NOTE The procedures in this section apply to predefined LUTs and LUTs that have been loaded. They neither apply to LUTs that have been imported nor 3D LUTs.

To monitor the R, G, and B channels independently:

- 1 From the Edit Curve box, select Red, Green, or Blue to monitor the red, green, or blue channels independently.

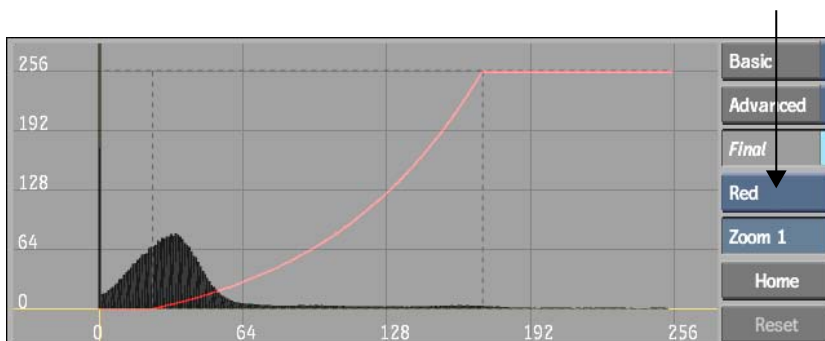

Modifying Reference White and Reference Black Values

The reference white and reference black values define the intensity levels at which incoming pixels are considered white or black respectively. For example, selecting a logarithmic-to-linear basic conversion LUT curve sets the reference white to 685 and the reference black to 95. (These have been shown to be good values for Kodak™ film stock.) As a result, source pixels with values from 685 and 1023 will produce white pixels, while those from 0 and 95 will be set to black.

Reference white and black are affected by the values assigned to highlights and shadows. White pixels are mapped to the value set for highlights, while black pixels are mapped to the value set for shadows. See [Modifying Highlights and Shadows](#) on page 757.

To modify reference white or black values using the Ref White and Ref Black fields:

- 1 Do one of the following:
 - To set proportional R, G, and B values, enable Prop and then enter the value in one of the (left-to-right) R, G, and B Ref White and Ref Black fields.
 - To set independent R, G, or B values, disable Prop and then enter the value in the corresponding (left-to-right) R, G, or B Ref White and Ref Black fields.

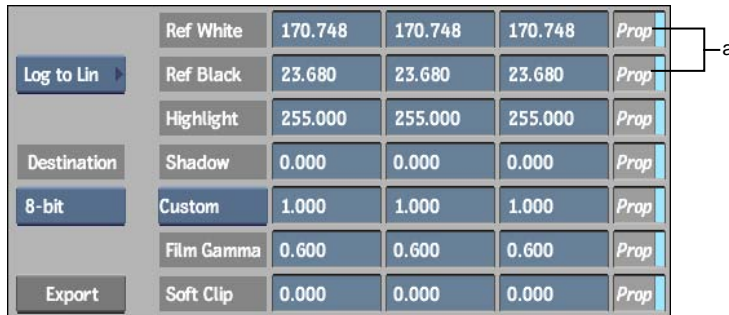

(a) Ref White/Black fields and Prop (Proportional) buttons

To modify reference white or black values using the LUT Editor graph:

- 1 Do one of the following:
 - To set proportional R, G, and B values, select All from the Edit Curve box, and then drag the vertical reference white or reference black line left or right.
 - To set independent R, G, or B values, select Red, Green, or Blue from the Edit Curve box, and then drag the vertical reference white or reference black line left or right.

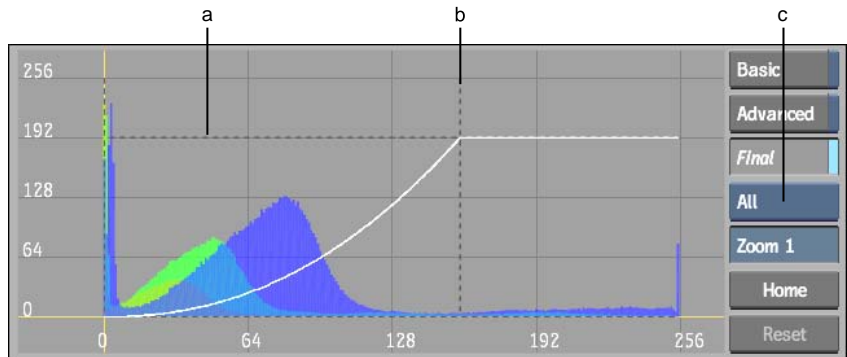

(a) Reference Black line (b) Reference White line (c) Edit Curve box

TIP If you already entered independent values and want to modify the R, G, and B values proportionally, you must drag the reference white or reference black line that corresponds to the corresponding channel. To view the selected R, G, or B luma values as a greyscale luma image in the Import Image menu, enable the Exclusive button.

Modifying Highlights and Shadows

Highlight and shadow values define the maximum and minimum values permitted for each channel. All values above the highlight are clamped down to it. Similarly, all values below the shadow are clamped up.

To modify highlight and shadow values using the Highlights and Shadows fields:

- 1 Do one of the following:
 - To set proportional R, G, and B values, enable Prop and enter a value in one of the (left-to-right) R, G, and B Highlights and Shadows fields.
 - To set independent R, G, or B values, disable Prop and enter the value in the corresponding (left-to-right) R, G, or B Highlights and Shadows fields.

	Ref White	170.748	170.748	170.748	Prop
Log to Lin ▾	Ref Black	23.680	23.680	23.680	Prop
	Highlight	255.000	255.000	255.000	Prop
Destination	Shadow	0.000	0.000	0.000	Prop
8-bit	Custom	1.000	1.000	1.000	Prop
	Film Gamma	0.600	0.600	0.600	Prop
Export	Soft Clip	0.000	0.000	0.000	Prop

(a) Highlight/Shadow fields

To modify highlight or shadow values using the LUT Editor graph:

- 1 Do one of the following:
 - To set proportional R, G, and B values, select All from the Edit Curve box, and then drag the horizontal highlight or shadow line up or down.
 - To set independent R, G, or B values, select Red, Green, or Blue from the Edit Curve box, and then drag the horizontal highlight or shadow line up or down.

Modifying the Gamma of the Conversion Curve

Set the gamma correction value to correspond to the display gamma you set your system to use. You can select a preset from the Gamma Correction box or enter a custom value.

To modify the gamma correction curve using the Gamma Correction fields:

- 1 Select an option from the Gamma Correction box.



(a) Gamma Correction fields (b) Gamma Correction box

Select:	To:
Video Display	Set video gamma correction presets.
Custom	Enter custom gamma values.

2 If you selected Custom, do one of the following:

- To set proportional custom R, G, and B gamma correction values, enable Prop, and then enter the value in one of the (left-to-right) R, G, and B Gamma Correction fields.
- To set independent custom R, G, or B gamma correction values, disable Prop, and then enter the value in the corresponding (left-to-right) R, G, or B Gamma Correction field.

To modify the gamma correction curve using the LUT Editor graph:

1 Do one of the following:

- To modify the combined R, G, and B gamma correction curves proportionally, select All from the Edit Curve box, and then drag the gamma correction curve left or right.
- To set independent R, G, or B values, select Red, Green, or Blue from the Edit Curve box, and then drag the gamma correction curve left or right.

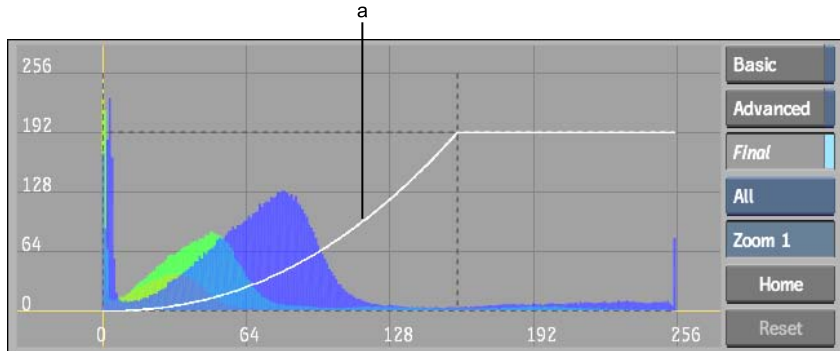

(a) Gamma correction curve

Modifying the Gamma of the Incoming Film Negative

The values in the Film Gamma fields affect the gamma correction curve inversely to the Gamma Correction fields. This is because the gamma correction performed using these controls is based on the gamma of the original film negative. Typically, the gamma of a film negative is 0.6. Only adjust this value if your film negative is of a non-standard gamma. You should not have to modify this value by very much.

NOTE Film Gamma fields are not available if you are using the LUT Editor node in Batch because in the middle of a process pipeline you typically input a source that has already been gamma corrected for your display environment. In this case, you generally use the LUT Editor to apply a static colour correction.

To modify the gamma correction curve using the Film Gamma fields:

- 1 Do one of the following:
 - To set proportional custom R, G, and B gamma correction values, enable Prop and then enter the value in one of the (left-to-right) R, G, and B Film Gamma fields.
 - To set independent custom R, G, or B gamma correction values, disable Prop and then enter the value in the corresponding (left-to-right) R, G, or B Film Gamma field.

	Ref White	170.748	170.748	170.748	Prop
Log to Lin ▾	Ref Black	23.680	23.680	23.680	Prop
	Highlight	255.000	255.000	255.000	Prop
Destination	Shadow	0.000	0.000	0.000	Prop
8-bit	Custom	1.000	1.000	1.000	Prop
	Film Gamma	0.600	0.600	0.600	Prop
Export	Soft Clip	0.000	0.000	0.000	Prop

(a) Film Gamma fields

Adjusting the Softclip Values

You can soften the shoulder of the gamma correction curve by adjusting the Softclip values. When you soften the shoulder of the conversion curve, you soften the transition of colours toward the reference white value. This results in less harsh highlights in your clip.

To soften the shoulder of the gamma correction curve using the Softclip fields:

- Do one of the following:
 - To set proportional custom R, G, and B gamma correction values, enable Prop, and then enter the value in one of the (left-to-right) R, G, and B Softclip fields.
 - To set independent custom R, G, or B gamma correction values, disable Prop, and then enter the value in the corresponding (left-to-right) R, G, or B Softclip field.

	Ref White	170.748	170.748	170.748	Prop
Log to Lin ▾	Ref Black	23.680	23.680	23.680	Prop
	Highlight	255.000	255.000	255.000	Prop
Destination	Shadow	0.000	0.000	0.000	Prop
8-bit	Custom	1.000	1.000	1.000	Prop
	Film Gamma	0.600	0.600	0.600	Prop
Export	Soft Clip	0.000	0.000	0.000	Prop

(a) Soft Clip fields

To soften the shoulder of the gamma correction curve using the LUT Editor graph:

- 1 Do one of the following:
 - To soften the shoulder of the combined R, G, and B gamma correction curves proportionally, select All from the Edit Curve box, and then **Shift-drag** the gamma correction curve left or right.
 - To soften the shoulder of the R, G, or B curves separately, select Red, Green, or Blue from the Edit Curve box, and then **Shift-drag** the gamma correction curve left or right.

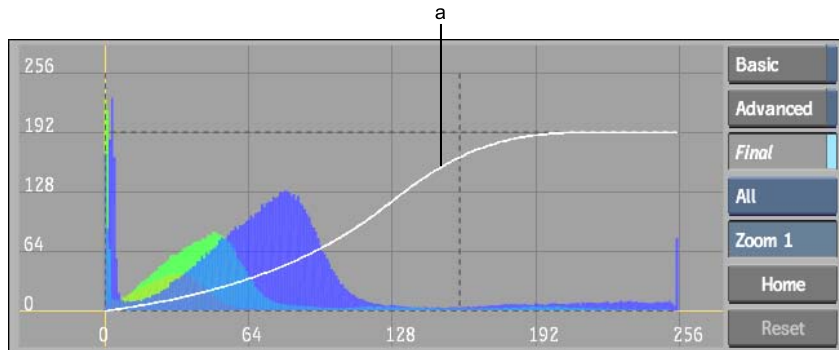

(a) Softened shoulder

Advanced Editing of the Conversion LUT Curve

After you modify the basic conversion LUT curves, you may want to further refine the final result. To do so, you can use advanced editing tools. With advanced editing, you modify additional curves for the red, green, and blue channels to fine-tune the final conversion LUT and bring out or hide detail in specific areas. These curves have editable points, adding flexibility in how they affect each channel in the final conversion LUT.

You can modify the shape of each advanced editing curve using control points. Modifications you make to these curves influence the curve of corresponding channels in the final conversion LUT. For example, you can add points to the advanced editing curve for the red channel, and by dragging the points, affect the slope of the red channel's final conversion LUT curve.

The modifications you make to the basic conversion LUT curves and the advanced editing curves are independent. The final LUT that you generate, however, is a single curve (or set of R, G, and B curves) that consists of basic LUT curves and adjustments you make with advanced editing curves.

NOTE The procedure in this section does not apply to 3D LUTs.

To perform advanced editing of the conversion LUT curve:

- 1 In the LUT Editor, click Advanced.

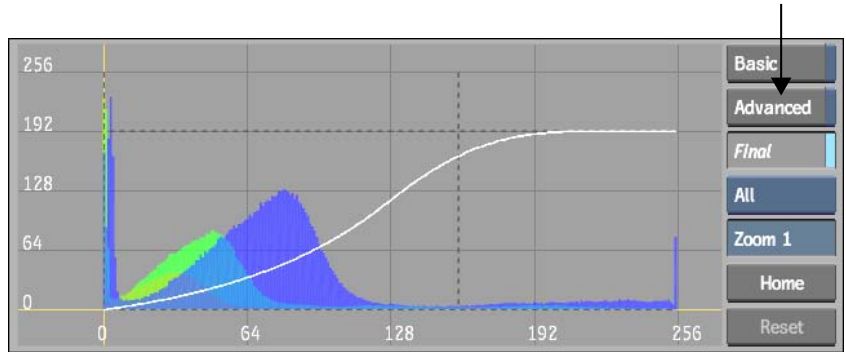

Additional advanced editing curves appear for the red, green, and blue channels. RGB curves use blending to distinguish overlapping curves. For example, when all RGB curves overlap, a white curve is produced, whereas green and blue overlapping curves produce a cyan curve.

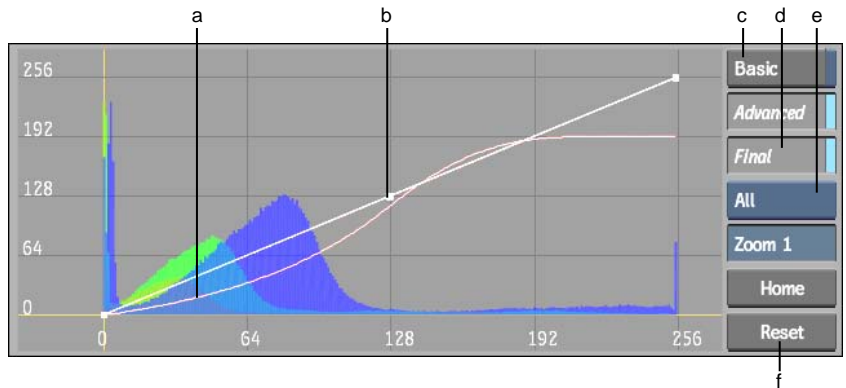

(a) Red, blue and green overlapping advanced editing curves (b) Control point (c) Basic button (d) Final button (e) Edit Curve box (f) Reset button

- 2 To adjust the R, G, and B curves more easily, select one of the channels from the Edit Curve box.

The corresponding channel's basic and advanced editing curves are displayed. The histogram only displays values for the selected channel.

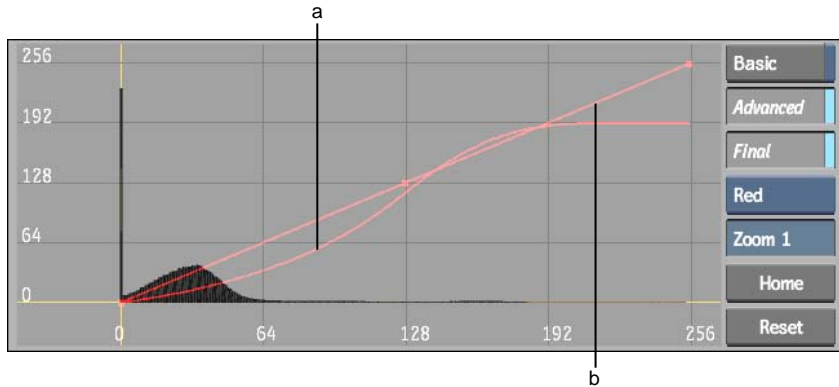

(a) Color channel selected in Edit Curves box (b) Color channel's advanced editing curve

- 3 To modify the advanced editing curves, use the Edit Mode box.

Select:	To:
Add	Add control points to an advanced editing curve. With Add selected, click either the red, green, or blue advanced editing curve.
Delete	Delete control points from an advanced editing curve. With Delete selected, click a point on the red, green or blue advanced editing curve.
Move	Move control points. With Move selected, drag the points, or press Ctrl -drag to select multiple points.
<p>TIP Since the advanced editing curves use B-spline interpolation, the control points you manipulate will not necessarily rest on the curve itself. Points have a weighted influence on the curve depending on the position of the other points on the curve.</p>	
Zoom	Zoom in on the curves. With Zoom selected, drag over the curves right or left to zoom in or out.

Select:	To:
Rect Zoom	Zoom in on a section of the curves. With Rect Zoom selected, drag a selection box to zoom in on the area of the curves contained by the selection box.
Pan	Pan the curves. With Pan selected, drag over the curves to pan the curves in any direction.

Dragging control points of advanced editing curves affects the basic curves and the colour effect is immediately reflected in the clip.

- To view the basic and final conversion LUT curves, toggle the Basic LUT and Final LUT buttons.
- To reset the advanced editing curves only, click Reset.

Comparing Colour Values Using Colour Patches

While creating the LUT, you may want to sample image channel values in the source, result, and reference clips to compare values of similar colours, or even corresponding pixels. The colour patches appear to the right of the LUT Editor graph.

NOTE The procedures in this section do not apply to 3D LUTs.

To sample colours in the LUT Editor accessed from the Import Image menu:

- Click the Source or Result colour patch.

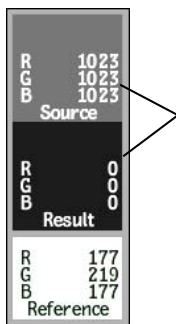

The cursor changes to a colour picker.

- 2 Click the image.

Both source and result colours are sampled simultaneously. The RGB values for the selected pixel are displayed, and the sampling boxes take on the corresponding colour.

- 3 To sample a set of reference values, click the Reference sampling box and use the colour picker to sample the image.

The values are taken from either the result or reference image, depending on which clip display option is currently selected.

To use colour patches in the LUT Editor menu in Batch:

- 1 Click the Source or Result sampling box.

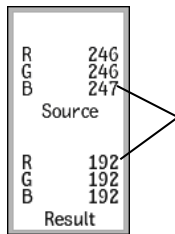

The cursor changes to a colour picker.

- 2 Click the image.

Both source and result colours are sampled simultaneously. The RGB values for the selected pixel are displayed, and the sampling boxes take on the corresponding colour.

Saving LUT Editor Setups

If you will be importing a series of clips from the same shoot or stock, consider using a LUT Editor setup. LUT setups retain all menu settings for the basic conversion LUT curve as well as those created when performing advanced editing. Because a LUT setup preserves the distinction between settings in the LUT Editor menu and adjustments made with the advanced editing curves, it is easier to fine-tune the LUT for specific clips. When importing multiple clips from the same shoot or film stock, later clips may require fine-tuning using the advanced editing curves, but much of the initial work will have been done in the menu.

A LUT setup is simply a 1D LUT that has been saved, rather than exported—saving preserves menu settings; exporting does not. When you re-load a saved LUT, menu settings and advanced editing curve values are restored, and you can adjust basic and advanced editing curves independently. In addition, saving automatically creates an inverse LUT.

When working with film, you normally apply the LUT you created when importing the clip, and the inverse LUT—created automatically upon saving—when exporting your finished work. Applying the export LUT restores the clip's logarithmic data in preparation for the film print. In addition, Flame adds the correct *.lut* extension, and for the inverse LUT, adds the *_inv* suffix to the filename.

To save a LUT Editor setup:

- 1 Access the LUT Editor.
- 2 Click Save.

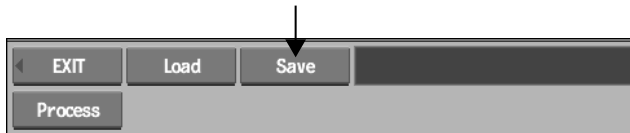

The file browser appears.

- 3 Set a location for the LUT.
- 4 Type a name for the LUT in the Save field.
- 5 If you accessed the LUT Editor in Batch or from the Desktop, select Setup from the Save option box.
- 6 Click Save.

The LUT and an inverse LUT are saved in the specified location.

Loading LUT Editor Setups

Loading a LUT Editor setup gives you access to the menu properties and advanced editing curves used to create the LUT.

You can load setups on image import from the Desktop and from the LUT Editor associated with any node in Batch.

To load a LUT Editor setup while importing images from the Desktop:

- 1 Access the LUT Editor.
- 2 Click Load.



The file browser appears.

- 3 Select the LUT Editor setup that you want to load.
You are returned to the LUT Editor and the setup is loaded.

To load a setup in the LUT Editor in Batch:

- 1 Access the LUT Editor.
- 2 Click Load.

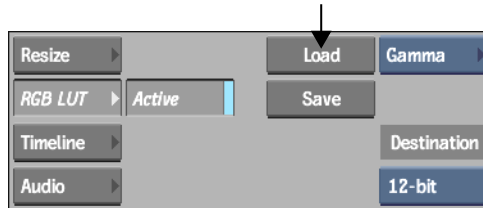

The file browser appears.

- 3 Locate and select the LUT Editor setup that you want to load.
You are returned to the LUT Editor and the setup file is loaded.

Exporting LUTs

Once you complete your custom LUT, you can use it to convert images. To do so, you must first save or export it. Saving a LUT preserves its menu settings and automatically creates an invert LUT. A LUT's menu settings include values for its basic curves, as well as its advanced editing curves. Exporting combines the basic curves and the advanced editing curves into a single set of curves. However, exporting provides the opportunity to change the bit depth of the

LUT. Both saved and exported LUTs are applied to an image sequence or a clip in Batch in the same manner.

When you export a LUT, the settings that correlate with the basic curves and the advanced editing curves are merged to create a single set of RGB conversion curves and the independence of these settings is lost. Whether you load or import the LUT afterwards, it appears as a basic conversion curve only. However, like all basic LUT types, you can then alter it, for example, by using the advanced editing curves.

Exported LUTs serve as a good interchange format for colour consistency between Autodesk and non-Autodesk products.

Exporting is useful when you want to change a LUT's bit depth. If you develop a LUT for importing 10-bit logarithmic film data, for example, you can easily convert it to work for 12-bit logarithmic data. When exporting a LUT, you can scale both the input and output bit depths.

To export a LUT:

- 1 Access the LUT Editor.

If you accessed the LUT Editor from a node in Batch, select the node and display the LUT editing menu with which you created the LUT.

- 2 Click Export.

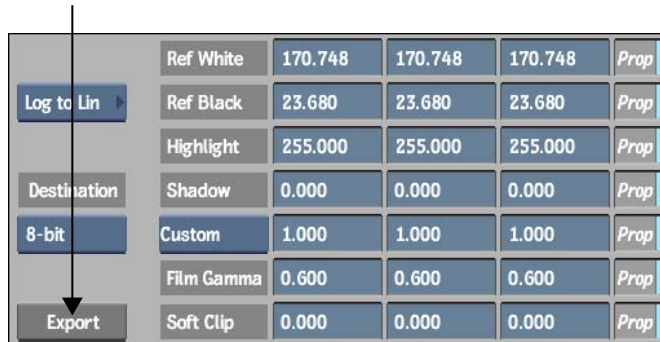

The Export LUT menu appears.

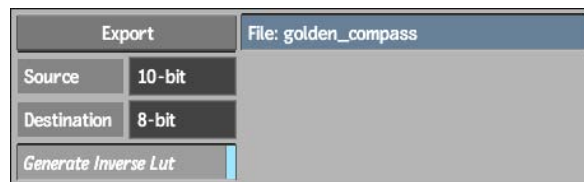

- 3 Set a location for the LUT.
- 4 Select the source and destination bit depths for the exported LUT.
- 5 Enable Generate Inverse LUT to create an inverse LUT along with the normal lut. You can apply an Inverse LUT to restore original LUT settings.
- 6 Click Export.

The LUT is exported to the specified location.

Converting OpenEXR Images

Flame supports the OpenEXR file format. This file format stores 16- or 32-bit floating-point image data. Advantages of the OpenEXR format include a high dynamic range, high-quality colour resolution, and portability.

From the Desktop or Batch, you can convert OpenEXR files using the LUT Editor. You can alter image channel values (such as the luminance) using the viewer's conversion controls, however, you cannot alter the original file.

You can convert the output of an OpenEXR image to an integer image with a bit depth of 8, 10, or 12 bits. At a destination bit depth of 12 bits, you can store packed data (which requires less space on the framestore) or unpacked data (which results in faster retrieval times). You still have the option of exporting to a new 16-bit floating point image.

The following steps are the suggested workflow when working with OpenEXR images.

Step:	Refer to:
1. Import the image.	Importing OpenEXR Files on page 218.
2. Work only with nodes, modules, and operations that support the OpenEXR image format (optional).	Accessing the Editing Menu on page 937 and Supporting Floating-point Images on page 1332.
3. Convert the image.	Converting an OpenEXR Image in the LUT Editor on page 771 and Using OpenEXR Images in Batch on page 1287.
4. Convert the image and make changes to the basic conversion curve and editing parameters, similarly to a 1D LUT. Export an 8-, 10-, or 12-bit	Converting an OpenEXR Image in the LUT Editor on page 771.

Step:**Refer to:**

integer image from the OpenEXR image.

To access EXR Display, open the LUT Editor from:

- The desktop LUT module
- A LUT Editor node
- In Batch, an OpenEXR-formatted clip

Converting an OpenEXR Image in the LUT Editor

You can convert the output of an OpenEXR image by accessing EXR Display controls in the LUT Editor.

To convert an OpenEXR file:

- 1 Access the LUT Editor. See [Accessing the LUT Editor](#) on page 745.
- 2 From the Conversion LUT Type box, select EXR Display.



The EXR Display controls appear.

Exposure Enter the display image exposure. Editing this value lightens or darkens the display image, revealing detail in the high or low range of luminance.

Defog Subtract from pixel values to reduce fogging of the image.

Knee Low Set the lower limit of a compressed pixel range. The knee function determines the white point and middle grey values of the image.

Knee High Set the upper limit of a compressed pixel range. The knee function determines the white point and middle grey values of the image.

Gamma Enter the gamma correction values for your screen setup.

P (Proportional) Enable to change remaining channel values proportionally with respect to a selected value.

- 3 In the Destination menu, select the output bit depth.

Adding and Removing Film Grain

30

Topics in this chapter:

- [About Film Grain](#) on page 773
- [Removing Grain from a Clip](#) on page 774
- [Adding Grain to a Clip](#) on page 779
- [Matching Grain between Clips](#) on page 788
- [Adding Grain with a Matte](#) on page 792
- [Defining the DeGrain and ReGrain Area](#) on page 794
- [Saving and Loading Grain Management Setups](#) on page 795

About Film Grain

Grain is a basic characteristic of film that is derived from the individual silver halide crystals randomly distributed across an image. The random distribution of these crystals creates the visual impression of graininess, which adds a distinctive look to film. In addition, different film stocks have different grain signatures.

You can use grain management tools to create convincing composites between video, or CG-generated elements, and film material. The DeGrain and ReGrain tools are useful in a number of scenarios. For example:

- If you are pulling keys from key-in film clips, film grain can make generating a clean matte more difficult. Using the DeGrain tool, you can remove the grain from the key-in clip, generate the matte from that clip, and apply the matte to the original grainy key-in clip. The result is a clean, precise matte applied to a properly grainy film clip.
- If you are mixing film clips originating from different film stocks, you can match the grain in the clips to make the grain in your results look consistent.
- If you are working with footage originally shot on film and transferred to video, you can remove the grain and match the film material with video material.
- If you are working with video material or CG-generated elements, you may want to add grain to the clips to result in a film look.
- You can use DeGrain tools to remove grain from film clips before performing any image processes. After you are finished, you can use ReGrain tools to restore the film grain to the final result.

Grain management workflow, much like working with LUTs, depends heavily on the specific qualities of the media you are working with. Use the procedures described in the following sections to put together the processing steps that you need to get the results that you want.

Removing Grain from a Clip

Use the DeGrain command to remove grain from a clip. DeGrain applies a noise reduction algorithm that consists of two filters:

- An RGB-averaging filter that removes noise and softens the image.
- An RGB-sharpening filter that adaptively restores the sharp details of an image.

When you remove grain from a clip, you start with the default values for these filters and adjust them to produce the degrained result that you need.

Because grain varies according to film stock, lighting conditions, colour, and resolution, it is advisable to create a DeGrain setup for each clip from which you want to remove grain.

To access DeGrain from the Desktop:

- 1 From the Main menu, click Processing, then click DeGrain.

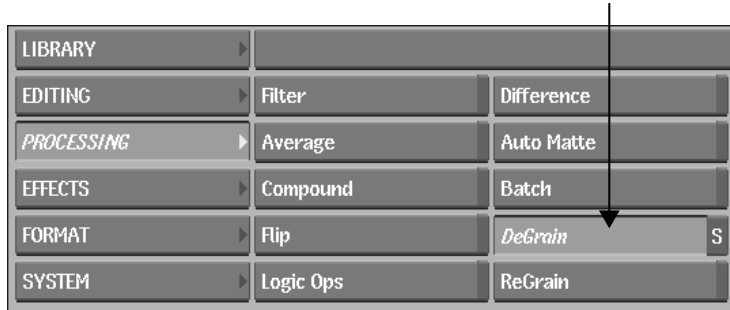

- 2 Select the clip from which you want to remove grain, and then select a destination reel.

The DeGrain menu appears.

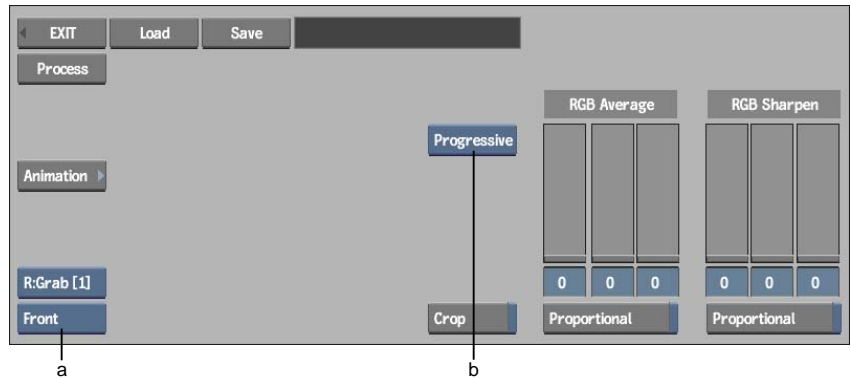

(a) View box (b) Render Method box

- 3 Optional: Click Reset All, and then Confirm, to reset DeGrain to the default settings.



- 4 By default, the result clip appears. You can also view the front clip by selecting Front from the View box.
- 5 To view the front and result clips simultaneously, and to speed up interactivity while defining the DeGrain parameters, enable the Crop button and use the crop box. See [Defining the DeGrain and ReGrain Area](#) on page 794.

To access DeGrain from Batch:

- 1 Drag a DeGrain node to the Batch desktop.
- 2 Parent the output from which you want to remove grain to the front clip input socket of the DeGrain node.
- 3 Select the DeGrain node.
The DeGrain menu appears.

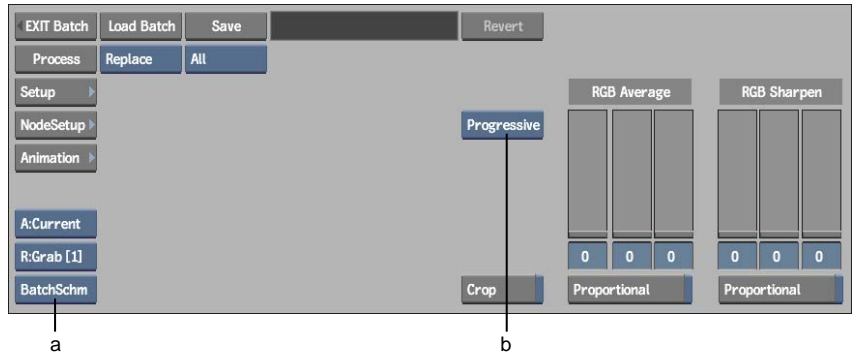

(a) View box (b) Render Method box

- 4 Press **Alt+2** to select the 2-Up viewport layout. With the viewport on the left set to display the front clip and the viewport on the right set to display the result clip, you can better track the effects of your changes against the front clip.
- 5 You can also use the crop box to view the front and results clips simultaneously, and to speed up interactivity. See [Defining the DeGrain and ReGrain Area](#) on page 794.
- 6 Use the reference buffer to store intermediate results as you set the grain removal parameters. See [Storing Reference Frames in the Reference Buffer](#) on page 133.

To remove grain from a clip:

- 1 Select an option from the Render Method box.

Select:	To:
Progressive	Remove grain from frame-based material, including film-based material transferred either to PAL without field interpolation, or to 30 fps field-based formats, provided 2:3 sequence has been removed.
Interlaced	Remove grain from field-based video, thus compensating for temporal jitter between fields in each frame.

- 2 Enable View.



- 3 In the View menu, use the R, G, and B buttons to control the display of the corresponding channels in the image window. You can also use the corresponding hot keys (**Shift+R**, **Shift+G**, or **Shift+B**) in the DeGrain menu. Enable Excl and then click R, G, or B to view each channel exclusively as a greyscale representation. You can also use the **Shift+X** hot key combination in the DeGrain menu to enable Excl. Use **Shift+Z** to restore the RGB view.

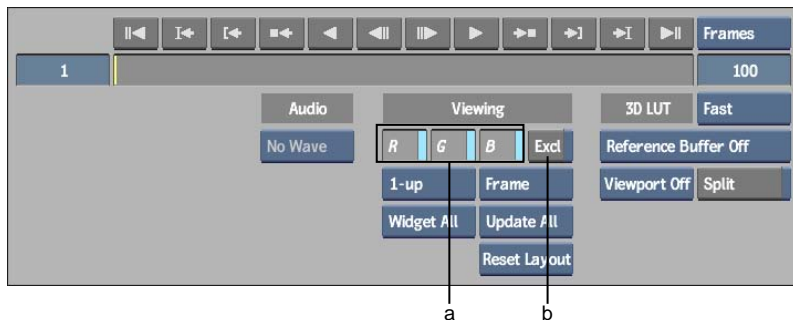

(a) Channel Display buttons (b) Exclusive button

- 4 Set the RGB Average Blur radius to remove the grain from the clip:
 - Enable Proportional and drag the sliders in the RGB Average group to average RGB globally. This is usually a good initial step.
 - Disable Proportional and adjust the R, G, and B sliders independently. Because film grain is not usually uniform through the R, G, and B channels, this is often a required step for fine-tuning the RGB Average.

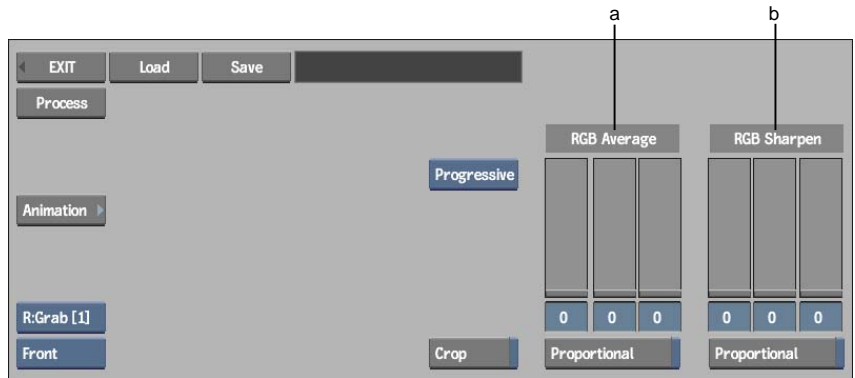

(a) RGB Average Blur controls (b) RGB Adaptive Sharpness controls

- 5 Set the RGB Adaptive Sharpness radius to restore sharpness where it is needed:
 - Enable Proportional and drag the sliders in the RGB Sharpness group to set RGB sharpness globally.
 - Disable Proportional and adjust the R, G, and B sliders independently.
- 6 When you are satisfied with the result, click Process to remove grain from the clip or continue building your processing pipeline, if you are in Batch.

Adding Grain to a Clip

Use the ReGrain command to restore the film grain on a clip that had been degraded, or to add grain to a clip originating on video or CG so as to make it look like film.

ReGrain synthesizes preset or custom grain signatures by modulating noise according to the luma of the image. This modulation is defined by granularity curves that specify the gain for the luma values of each channel.

- When you use a preset grain signature, these curves are implicit in the menu controls.
- When you define a custom grain signature, you work with these curves directly.

TIP If you want to colour correct a clip to which you are planning to add grain, you usually get better results when you colour correct the clip first, and then add the grain.

To access ReGrain from the Desktop:

- 1 From the Main menu, click Processing, then click ReGrain.

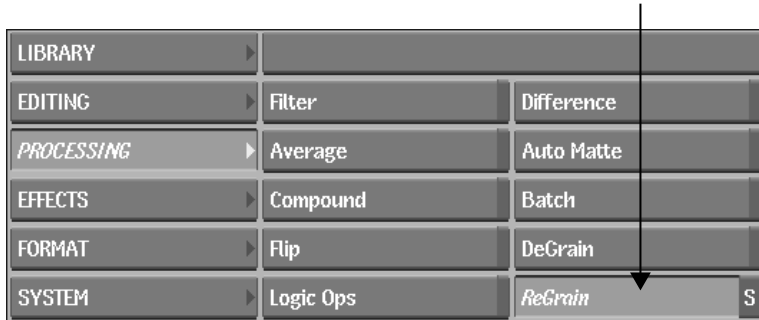

- 2 From the Input Mode box that appears, select Front.
- 3 Select the clip to which you want to add grain, and then select the destination reel for the processed clip.

The ReGrain menu appears.

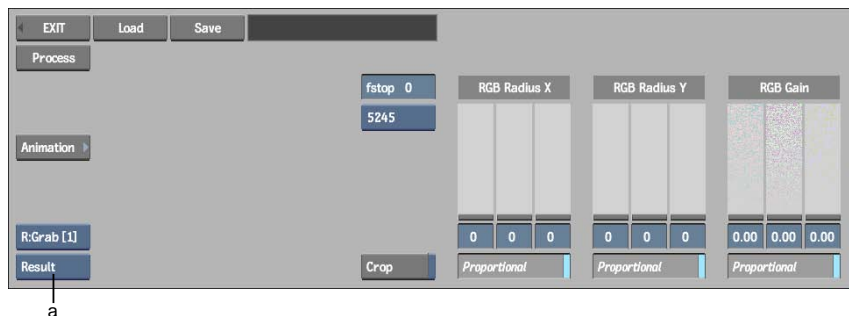

(a) View box

- 4 Optional: Click Reset All, and then Confirm to reset ReGrain to the default settings.



- 5 By default, the result clip appears. You can also view the front clip by selecting Front from the View box.
- 6 To view the front and result clips simultaneously, and to speed up interactivity while defining the ReGrain parameters, use the crop box. See [Defining the DeGrain and ReGrain Area](#) on page 794.

To access ReGrain from Batch:

- 1 Drag a ReGrain node to the Batch desktop.
- 2 Parent the output to which you want to add grain to the front clip input socket of the ReGrain node.
- 3 Select the ReGrain node.
The ReGrain menu appears.

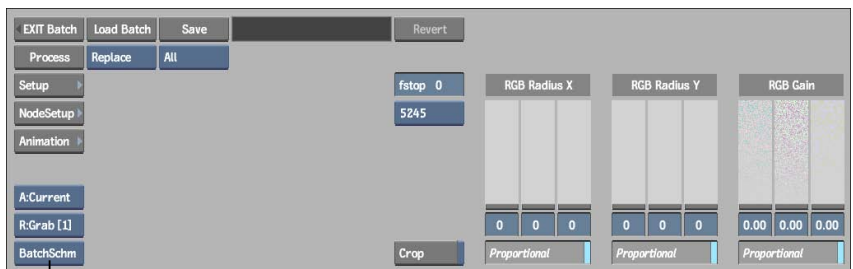

(a) View box

- 4 Press **Alt+2** to select the 2-Up viewport layout.

With the viewport on the left set to display the front clip and the viewport on the right set to display the result clip, you can better track the effects of your changes against the front clip.

- 5 You can also use the crop box to view the front and results clips simultaneously, and to speed up interactivity. See [Defining the DeGrain and ReGrain Area](#) on page 794.
- 6 Lastly, use the reference buffer to store intermediate results as you set the grain parameters. See [Storing Reference Frames in the Reference Buffer](#) on page 133.

Adding Grain Using a Preset Grain Signature

The easiest way to add grain to a clip is to select a preset grain signature, add and fine-tune the grain, and then adjust the radius until you get the result you are looking for.

To add grain using a preset grain signature:

- 1 Enable View to see the View menu.

Disable View to return to the ReGrain menu.



- 2 In the View menu, use the R, G, and B buttons to control the display of the corresponding channels in the image window. You can also use the corresponding hot keys (**Shift+R**, **Shift+G**, or **Shift+B**) in the ReGrain menu. Enable Excl and then click R, G, or B to view each channel

exclusively as a greyscale representation. You can also use the **Shift+X** hot key combination in the ReGrain menu to enable Excl. Use **Shift+Z** to restore the RGB view.

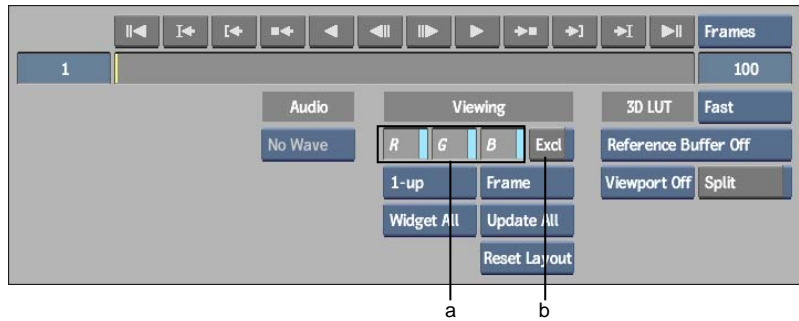

(a) Channel Display buttons (b) Exclusive button

- 3 In the ReGrain menu, from the Grain Signature box, select the preset option corresponding to the grain signature that you want to add. Grain signature presets are indicated by four-digit names that correspond to the film stock from which their grain signature is derived. These signatures are based on a colour noise filter.

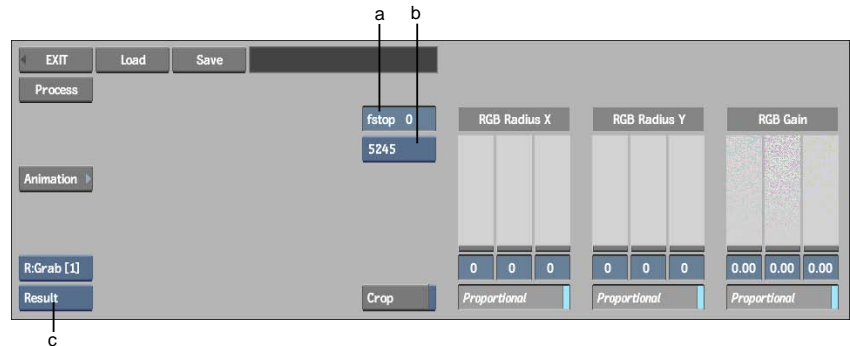

(a) fstop field (b) Grain Signature box (c) View box

- 4 To add grain to the clip, adjust the RGB Gain sliders:
 - Enable Proportional and drag the RGB Gain sliders to add grain proportionately to the Red, Green, and Blue channels.
 - Disable Proportional and adjust the R, G, and B channels independently to fine-tune the grain.

- 5 To compensate for under or overexposure, set the relative exposure offset by entering a value in the fstop field.
The range of permissible fstop values is from -3 to 3. Set a positive value to compensate for overexposure or a negative value to compensate for underexposure. Values entered must be integers.
- 6 To adjust the radius of the grain along the X-axis, drag the RGB Radius X sliders:
 - Enable Proportional and drag the RGB Radius X sliders to add grain proportionately to the R, G, and B channels.
 - Disable Proportional and adjust the R, G, and B channels independently to fine-tune the grain radius.
- 7 To adjust the radius of the grain along the Y-axis, drag the RGB Radius Y sliders:
 - Enable Proportional and drag the RGB Radius Y sliders to add grain proportionately to the R, G, and B channels.
 - Disable Proportional and adjust the R, G, and B channels independently to fine-tune the grain radius.
- 8 When you are satisfied with the result, click Process to add grain to the clip or continue building your processing pipeline in Batch.

Adding Monochrome Grain

Using the preset B/W grain signature option, you can also add grain generated by a monochrome noise filter. This option is useful if you are adding grain to monochrome clips.

Monochrome noise does not have to be black and white noise. You can adjust the RGB Gain sliders to tint the grain in cases where you are adding grain, for example, to sepia monochrome clips.

To add monochrome grain using the B/W option:

- 1 From the Grain Signature box, click B/W.

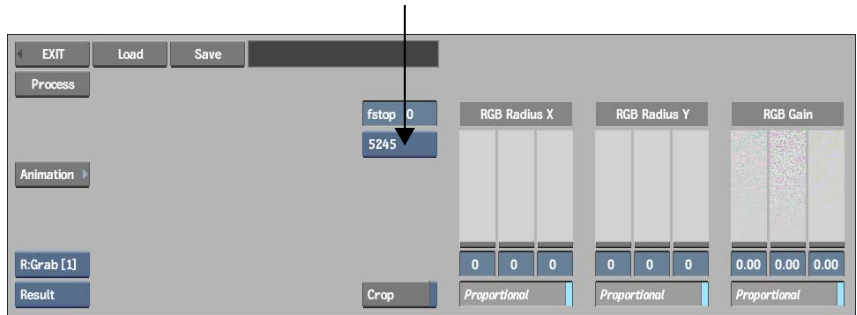

The B/W option applies grain with a preset gain algorithm.

- 2 To add grain to the clip, adjust the RGB Gain sliders:
 - Enable Proportional and drag the RGB Gain sliders to add grain proportionately to the R, G, and B channels.
 - Disable Proportional and adjust the R, G, and B channels independently to fine-tune the grain. This step is required if you want to tint the monochrome grain.
- 3 To compensate for under or overexposure, set the relative exposure offset by entering a value in the fstop field.
The range of permissible fstop values is from -3 to 3. Values entered must be integers.
- 4 To adjust the radius of the grain along the X-axis, drag the RGB Radius X sliders:
 - Enable Proportional and drag the RGB Radius X sliders to add grain proportionately to the R, G, and B channels.
 - Disable Proportional and adjust the R, G, and B channels independently to fine-tune the grain radius.
- 5 To adjust the radius of the grain along the Y-axis, drag the RGB Radius Y sliders:
 - Enable Proportional and drag the RGB Radius Y sliders to add grain proportionately to the R, G, and B channels.
 - Disable Proportional and adjust the R, G, and B channels independently to fine-tune the grain radius.
- 6 When you are satisfied with the result, click Process to add grain to the clip or continue building your processing pipeline in Batch.

Adding Grain Using a Custom or Monochrome Grain Signature

Use the Custom option to define Red, Green, and Blue Gain curves that are used to generate the grain signature.

Using the Mono option, you can also apply custom monochrome noise, an option that is useful if you are adding grain to monochrome clips. Monochrome noise does not have to be black and white noise. You can adjust the Red, Green, and Blue curves to tint the grain in cases where you are adding grain to, for example, sepia monochrome clips.

To add grain by defining a custom colour or monochrome grain signature:

- 1 From the Grain Signature box, click Custom or Mono.

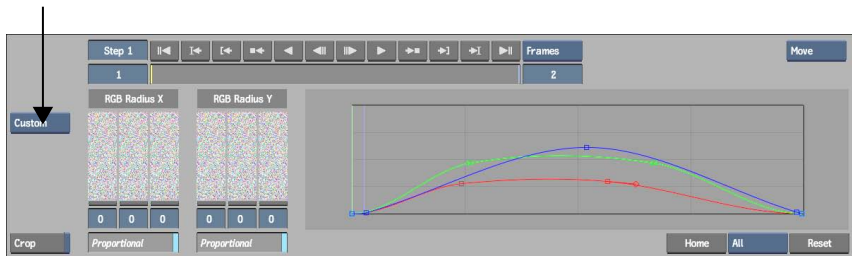

Instead of RGB sliders, the Custom option provides Red, Green, and Blue Gain curves for each channel that you can edit to produce the grain signature that you need:

- If you select Custom, the noise associated with the grain signature is colour noise.
 - If you select Mono, the noise is monochrome, though not necessarily black and white. You can tint the grain you add by adjusting the Red, Green, and Blue Gain curves.
- 2 To add grain to the clip, adjust the Red, Green, and Blue Gain curves. The Red, Green, and Blue Gain curves represent the degree of grain added along the vertical axis, and the corresponding luma value of the selected channel on the horizontal axis. For example, to add grain primarily at the higher luma range of the red channel, drag the right-most control point of the red curve upward.

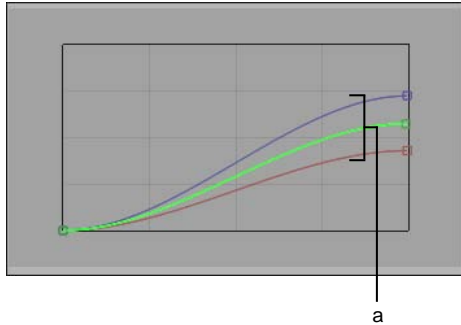

(a) Gain curves

The Red, Green, and Blue Gain graph provides a thorough set of controls that you can use to modify the Red, Green, and Blue Gain curves as needed:

- Select the curve that you want to modify by selecting the corresponding option from the Channel box below the RGB Gain graph.
 - To modify the shape of the selected curve, press **M** to select Move edit mode and then drag its control points.
 - To add control points to the selected curve, press **A** to select Add edit mode and then click the curve at the location where you want to add the control point.
 - To delete control points from the selected curve, press **D** to select Delete edit mode and then click the control point that you want to delete.
 - Use the other edit mode options as needed. Editing these curves and the options you can use are similar to editing animation curves. See [Editing Keyframes](#) on page 2001.
 - To undo the previous modification, click Undo.
 - To reset the RGB Gain curves, click Reset.
- 3 To adjust the radius of the grain along the X-axis, drag the RGB Radius X sliders:
- Enable Proportional and drag the RGB Gain sliders to add grain proportionately to the R, G, and B channels.

- Disable Proportional and adjust the R, G, and B channels independently to fine-tune the grain radius.
- 4 To adjust the radius of the grain along the Y-axis, drag the RGB Radius Y sliders:
 - Enable Proportional and drag the R, G, and B Gain sliders to add grain proportionately to the R, G, and B channels.
 - Disable Proportional and adjust the R, G, and B channels independently to fine-tune the grain radius.
 - 5 When you are satisfied with the result, click Process to add grain to the clip or continue building your processing pipeline in Batch.

Matching Grain between Clips

If you removed grain from a clip, for example, to perform rotoscoping, and you want to restore the original film grain, you can do so by analysing the grain signature of the original clip and applying it to the retouched clip.

Another grain-matching scenario is where you want to mix film clips that have different grain signatures. In this case, remove the grain from one of the clips and then analyse the grain of the other to apply it to the degrained clip.

To match grain between clips, you use the Front Back Matte input mode. Load the clip to which you want to add grain as the front clip, and the clip from which you want to analyse grain as the back clip.

When you match grain using clips on the desktop, you must also select a matte clip. See [Adding Grain with a Matte](#) on page 792. If you do not want to use the matte, simply turn it off.

To access ReGrain with Front Back Matte from the Desktop:

- 1 From the Main menu, click Processing, then click ReGrain.

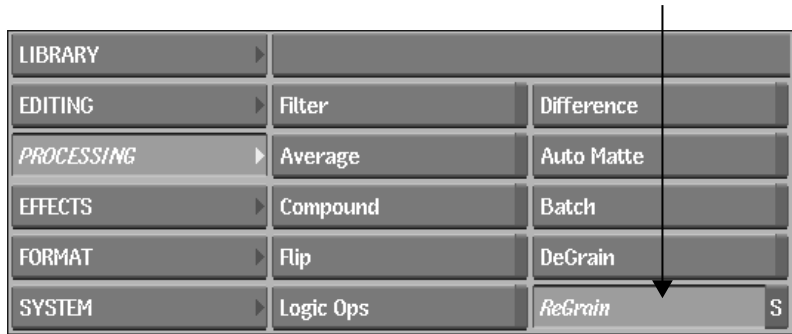

- 2 From the Input Mode box that appears, select Front Back Matte, and then do the following:
 - Select the clip to which you want to add grain as the front clip.
 - Select the clip from which you want to analyse the grain signature to match as the back clip.
 - If you want to add grain using a matte, select the matte that you want to use. See [Adding Grain with a Matte](#) on page 792. If you do not want to use a matte, select any clip and then turn the matte off.

The ReGrain menu appears.

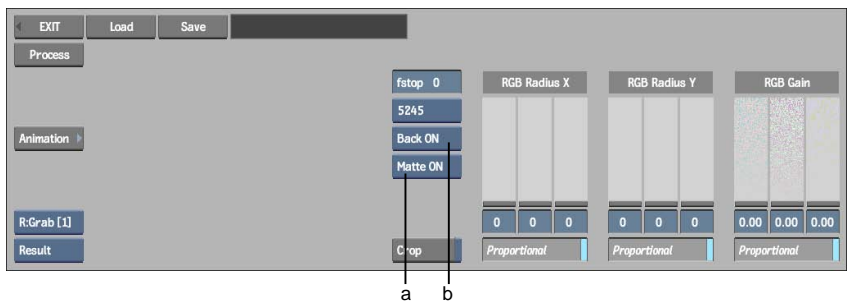

(a) Matte box (b) Back box

- 3 Optional: Click Reset All, and then Confirm to reset ReGrain to the default settings.
- 4 By default, the result clip appears. You can also view the front, back, and matte clips by selecting the corresponding option from the View box.

- To view the front and result clips simultaneously, and to speed up interactivity while defining the ReGrain parameters, use the crop box. See [Defining the DeGrain and ReGrain Area](#) on page 794.

You are now ready to analyse the grain in the back clip. See [Analysing the Grain in the Back Clip](#) on page 791.

To access ReGrain with Front Back Matte from Batch:

- Drag a ReGrain node to the Batch desktop.
- Parent the outputs for the grain matching process:
 - Parent the output to which you want to apply grain to the front input socket.
 - Parent the output from which you want to analyse the grain signature to match to the back input socket.
 - If you want to add grain using a matte, parent the output that you want to use as the matte to the matte input socket. If you do not want to use a matte, leave the matte input socket empty.
- Select the ReGrain node to view its menu.

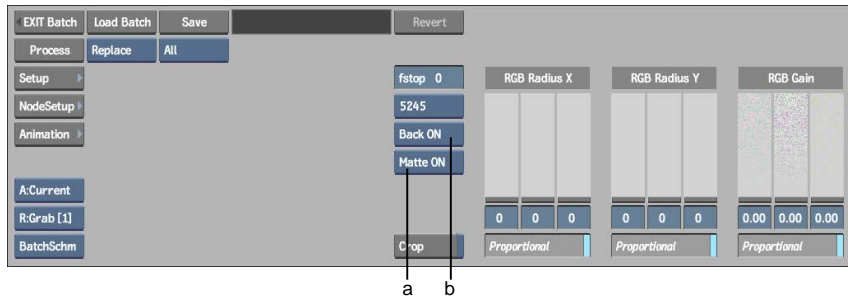

(a) Matte box (b) Back box

- Press **Alt+3** to select the 3-Up viewport layout. With the upper viewport set to display the result clip, the lower-left viewport set to display the front clip and the lower-right viewport set to display the back clip, you can better track your grain matching progress.
- You can also use the crop box to view the front and results clips simultaneously, and to speed up interactivity. See [Defining the DeGrain and ReGrain Area](#) on page 794.

- 6 Use the reference buffer to store intermediate results as you set the grain removal parameters. See [Storing Reference Frames in the Reference Buffer](#) on page 133.

Analysing the Grain in the Back Clip

Select the Custom option to analyse grain in the back clip.

To analyse the grain in the back clip:

- 1 From the Grain Signature box, select Custom.

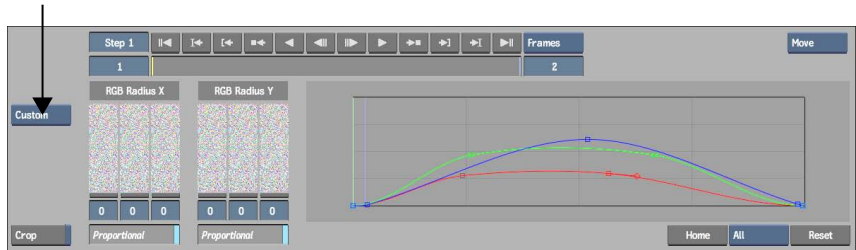

- 2 Look closely at the image and try to find three patches that best represent areas of shadow, midtone, and highlight. You will create control points for these on the curves for each of the red, green, and blue channels.
- 3 To analyse the grain for the red channel, go into the View menu, then enable Excl and the R button.
- 4 Viewing the back clip, press **Ctrl** and drag a selection box over an area in the back clip that is relatively uniform and predominantly red.
Control points appear for the red channel modifying the shape of the red curve based on the analysed sample.
- 5 Repeat steps 3 and 4 to analyse the grain in the green and blue channels.
- 6 For even more precise grain matching, repeat steps 3 and 4 for different luma ranges of the red, green, and blue channels.
The results produced by grain analysis may not be exactly what you want. If this is the case, you can modify the RGB Gain curves and adjust the size of the grain using the RGB X Radius and RGB Y Radius sliders.

Modifying the Results of the Analysis

Once you generate a match using the analysis technique, you can modify the result curve using the editing tools in the RGB Gain graph. See [Adding Grain Using a Custom or Monochrome Grain Signature](#) on page 786.

Adjusting the Grain Size

You can adjust the grain size if the grain match is not quite what you want. When you adjust the grain size, especially when trying to match grain, look at an area of intermediate brightness. The grain in dark areas sometimes appears larger than in bright areas because it is more difficult to distinguish between dark pixels.

To adjust the grain size:

- 1 To adjust the radius of the grain along the X-axis, drag the RGB X Radius sliders:
 - Enable Proportional and drag the RGB Gain sliders to add grain proportionately to the R, G, and B channels.
 - Disable Proportional and adjust the R, G, and B channels independently to fine-tune the grain radius.
- 2 To adjust the radius of the grain along the Y-axis, drag the RGB Y Radius sliders:
 - With Proportional enabled, drag the RGB Gain sliders to add grain proportionately to the R, G, and B channels.
 - Disable Proportional and then adjust the R, G, and B channels independently to fine-tune the grain radius.
- 3 When you are satisfied with the result, click Process to add grain to the clip or continue building your processing pipeline in Batch.

Adding Grain with a Matte

You can add grain using a matte, in which case grain is added to the clip only through the white or black areas of the matte, depending on which Matte option you select.

To add grain using a matte:

- 1 Load a matte clip into ReGrain:
 - If you are accessing ReGrain from the desktop, click ReGrain, select Front Back Matte from the Input Mode box, and then select the front, back, and matte clips that you want to load.

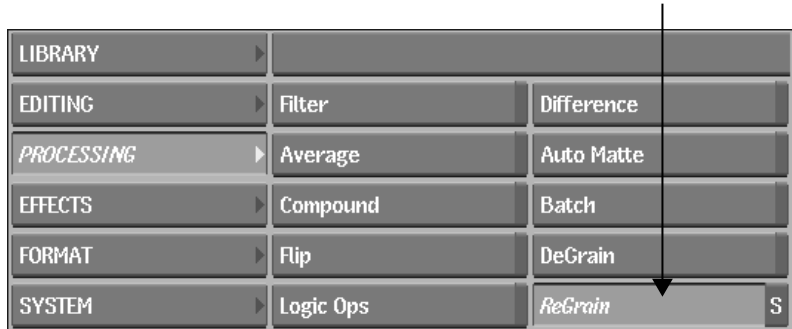

- If you are accessing ReGrain in Batch, parent the output that you want to use as the matte to the matte input socket.
- 2 Select an option from the Matte box.

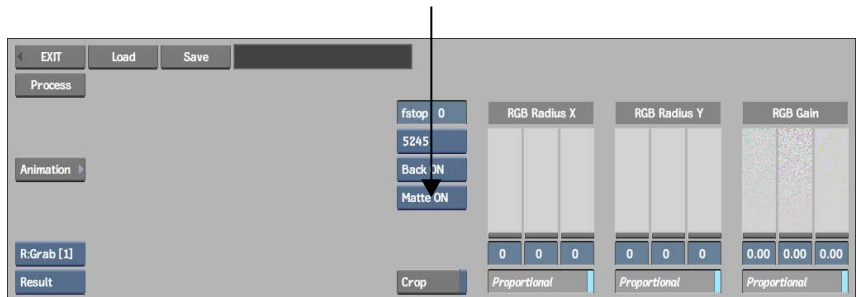

Select:	To:
Matte On	Add grain to part of the image corresponding to the white part of the matte.
Matte In-vert	Add grain to part of the image corresponding to the black part of the matte.
Matte Off	Add grain to the entire front clip.

TIP You can also turn off the Back clip by selecting Back Off from the Back button.

- 3 If you accessed ReGrain in Batch, unparent the matte clip to disable it.

TIP To invert the matte, use a Negative node or select Matte INV.

Defining the DeGrain and ReGrain Area

You can use a crop box to apply DeGrain and ReGrain processes to a specific region of the front clip rather than the entire clip. Because grain management is typically performed when you work with high-resolution film clips, using the crop box can greatly increase interactivity while setting DeGrain and ReGrain parameters.

To define the DeGrain and ReGrain area:

- 1 In the DeGrain or ReGrain menu, enable Crop.

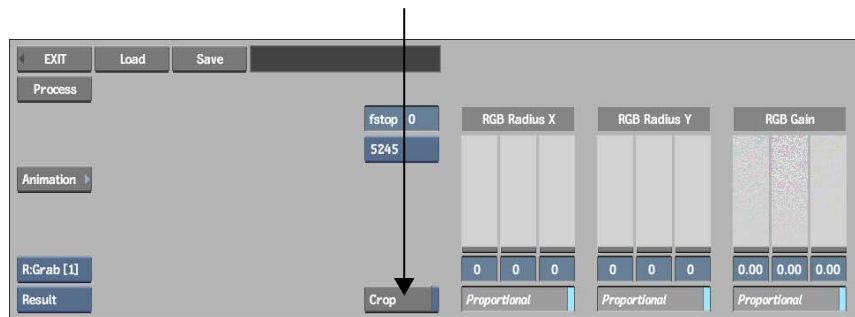

- 2 Drag a selection box over the image to define the specific region inside which you want the DeGrain or ReGrain process to be applied.
- 3 To change the position or size of the crop box, drag a new selection box. The new crop box replaces the previous one. The clip can now be processed from Batch (the crop box does not affect clip processing from the desktop).

NOTE To apply the DeGrain or ReGrain process to the entire clip, disable Crop.

Saving and Loading Grain Management Setups

If you have a series of clips originating from the same shoot from which you want to remove grain or to which you want to add grain, saving and loading setups greatly accelerates the process. Although the current clip may require particular tweaks from a setup that was created for another clip, loading the initial setup takes care of the preliminary steps and gives you a good starting point.

By default, DeGrain setups are saved in your project's `~/degrain` directory and use the `.degrain` extension. ReGrain setups are saved in your project's `~/regrain` directory and use the `.regrain` extension.

To save setups in DeGrain or ReGrain:

- 1 In the DeGrain or ReGrain menu, click Save.

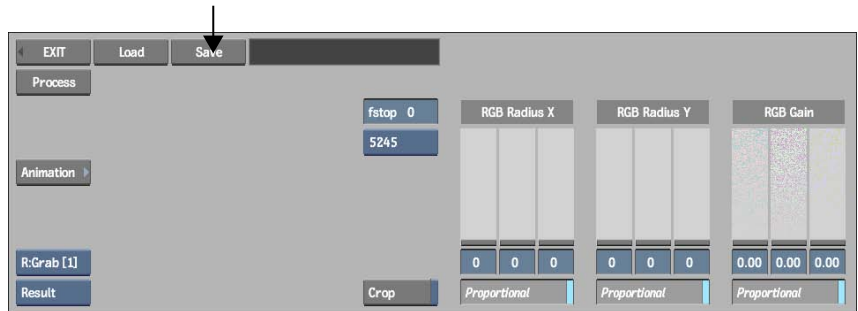

The file browser appears.

- 2 Set a location for the setup file, enter a name, select Setup from the Save Mode box, and then click Save.

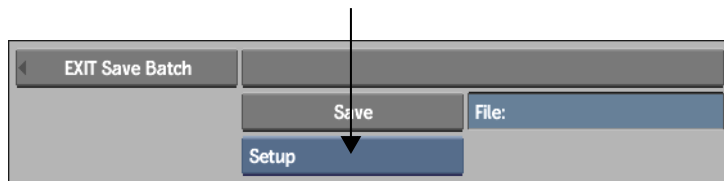

NOTE To avoid file compatibility issues between platforms, ensure that your file name does not contain any of the following characters: ` # ~ @ \$ % ^ & * () [] { } < > \ | / ! ? , ; ' "

To load setups in DeGrain or ReGrain:

- 1 In the DeGrain or ReGrain menu, click Load.

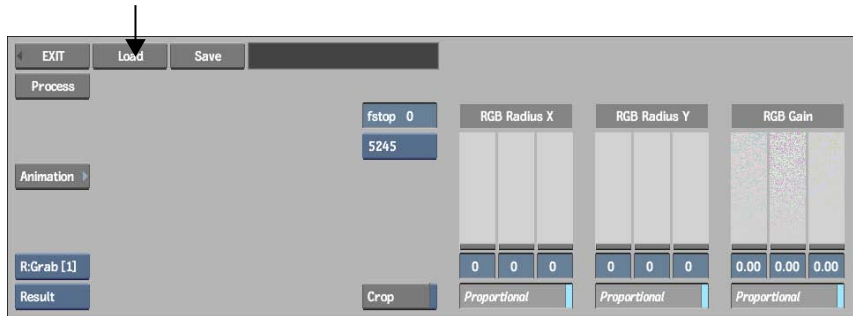

If you are in Batch, click Load Batch.

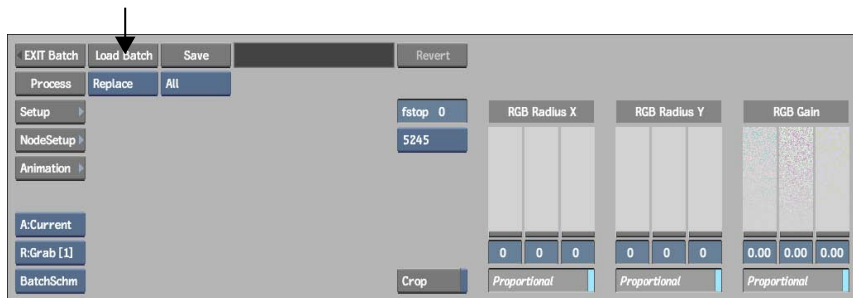

The file browser appears.

- 2 From the Load Mode box, select Setup, locate the setup file that you want to load, and then click Load.

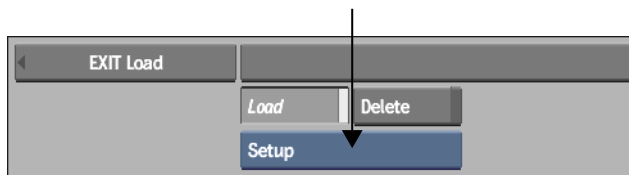

Part 7: Managing Your Work Environment

Part 7 includes these chapters:

- [Saving Setups and Preferences](#) on page 799
- [Clip History](#) on page 807
- [Setting Preferences](#) on page 827
- [Managing Hot Keys](#) on page 863
- [Installing Fonts](#) on page 873
- [Utilities](#) on page 877
- [Command Line Start-up and Exit Options](#) on page 919



Image courtesy of The Syndicate

Saving Setups and Preferences

31

Topics in this chapter:

- [About Setups and Preferences](#) on page 799
- [Accessing Directories](#) on page 800
- [Saving, Loading, and Deleting Items](#) on page 802
- [Setting the Default Preferences](#) on page 805

About Setups and Preferences

In all Flame modules, you can save the changes made to a clip (setups). In most modules, you can save settings and user preferences to customize the way a module works (preferences). You can then retrieve and use the setups and preferences in a later work session.

Setups

A setup is a file that contains a record of all changes you make to a clip in a particular module. This record includes references to clips used—not the clips themselves. Setups let you save your work separately from clips, so you can load and work on the setup at anytime or apply the setup to other clips. You can

create different setups during a single work session, including text setups, key setups, custom filters, and images. For example, when you save an Action setup, all menu parameters, layers, clip references—everything you need to rebuild the scene—are saved in the setup.

When you save a process tree in Batch, the settings and clip references for the various nodes contained in a process tree are saved in the Batch setup. When you load a setup from another project, you will not have access to the referenced clips unless you enable the associated clip libraries in the Network menu or copy the clips over to the current project.

NOTE Only Batch and Action setups include clip references.

By default, each type of setup is stored in a separate directory. For example, the *resize* directory stores resize setups, the *picture* directory in Paint stores single images, and the *correct* directory stores colour correction setups.

You can also archive setups. See [Archiving and Restoring Setups](#) on page 655.

Preferences

Preferences are settings that let you customize the display or functioning of some module elements, hot keys, the Desktop, pen and tablet, and audio. You can save preferences to a file and retrieve them at a later time. Examples of preferences are the Auto Key setting in many modules and the Texture option in the Action Setup menu. Like setups, each type of preference is stored in a separate directory.

You set module preferences in the Setup menu of each module, hot key preferences in the Hot Key Editor, and system-level preferences in the Preferences menu. System-level preferences (Desktop, pen and tablet, and audio) are saved for each user when you exit Flame, and are retained for future Flame sessions. You must save module preferences if you wish them to be available for future sessions.

Accessing Directories

When you save a setup or preference in a directory, it is saved as a file in a directory in the filesystem. Each file and subdirectory in the filesystem has a path—a series of parent directory names separated by slashes (/)—that the operating system uses to locate the file or subdirectory. Each type of setup and preference has a different default directory, and therefore a different path.

The default directory is accessed when you save or load setups and preferences. You specify the default location for your setup directories when you create your project, and the default location for your preference directories when you create a new user. The default path for setups is listed in the Environment Directory Pathnames section of the project configuration file.

All modules contain a Save As button and a Load button for saving and loading setups and preferences, found in the module's Setup menu.

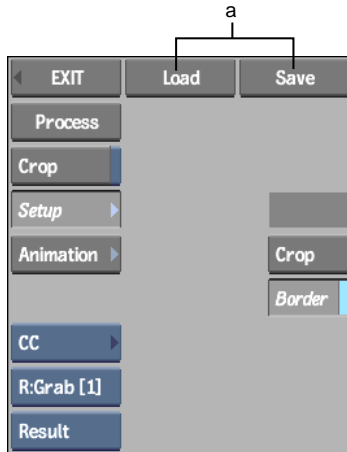

(a) Save and Load buttons

Use these buttons to save, load, and delete setups and preferences from the directories. For example, in the Colour Corrector Setup menu, you can use the Save As button to save setups to the Colour Corrector setup directory and the Load button to load a previously saved setup.

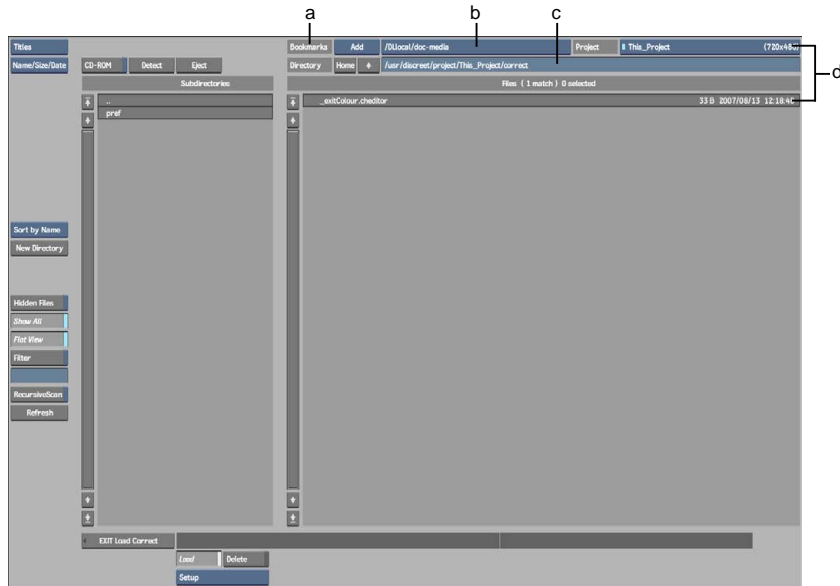

(a) Add/Delete Bookmarks box (b) Bookmarks list (c) Setups directory (d) Previously saved setups

TIP Select Add in the Add/Delete Bookmarks box to add a bookmark to a frequently referenced path. To later recall the bookmark, select the bookmark from the Bookmarks list.

When you open a directory, all the setups or preferences of the item type selected in the Load option box appear in the file browser. Use the file browser to select the setup or preference you want to save or load.

NOTE By default, only items of the current item type are displayed in the directory.

Saving, Loading, and Deleting Items

You can save, load, and delete setups and preferences from directories. When you load setups that were created using a project whose resolution is different from the resolution of the current project, the setups are often scaled to conform to the resolution of the current project. In instances where the setup is not scaled automatically, a Scale Setup button appears in the Setup menu of the module. See [Loading Garbage Mask Setups](#) on page 1758.

NOTE The Paint module has additional features you can use when saving setups. See [Paint: Setups](#) on page 2523.

To save an item to a directory:

- 1 In the Setup menu of a module, click Save.

The file browser appears in the upper part of the screen and the Save menu appears in the lower part. The file browser points to the default directory for the item type currently selected in the Save option box.

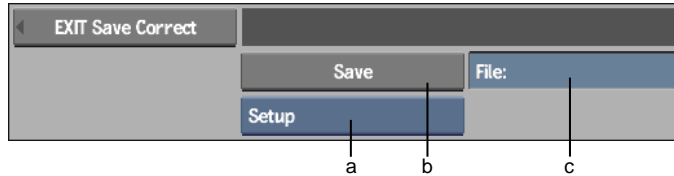

(a) Save option box (b) Save button (c) Filename field

- 2 Select the type of item you want to save, if there is a Save option box. (If there is no Save option box, you can only save one type of item, the setup file for the module.)
- 3 In the Filename field, enter a name for the item you are saving and press **Enter**. When resaving an item, simply click Save.

The item is saved and you are returned to the previous menu.

NOTE If the directory already contains an item with the same name, a warning message appears in the message bar, as well as a Confirm button. Click the Confirm button (or press **Enter**) to overwrite the file, or click elsewhere to cancel the command. To bypass the Confirm button when resaving items, press **Alt+Enter**.

To load an item from a directory:

- 1 In the Setup menu of a module, click Load.

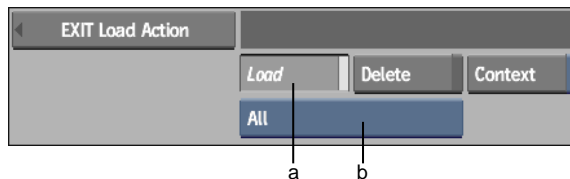

(a) Load button (b) Load option box

The file browser appears in the upper part of the screen, and the Load menu appears in the lower-left corner. The file browser points to the default directory for the option currently selected in the Load option box.

- 2 Select the type of item you want to load, if there is a Load option box. (If there is no Load option box, you can only load one type of item, a setup file for the module.)

The directory for the selected option appears.

- 3 If the setup you want to load is located in a different directory, use the file browser to change directories. To load a setup from a different project, select the project from the Project box.

For information on using the file browser, see [Navigating the Filesystem](#) on page 82.

- 4 Select the title (or proxy) of the item you want to load.

The item is loaded, and you are returned to the previous menu.

To delete an item from a directory:

- 1 In the Setup menu of a module, click Load.

The file browser appears in the top part of the screen, and the Load menu appears in the lower-left corner. The file browser points to the default directory for the option currently selected in the Load option box.

- 2 Select the type of item you want to load, if there is a Load option box. (If there is no Load option box, you can only load one type of item, a setup file for the module.)

The directory for the selected option appears.

- 3 If the setup you want to delete is located in a different directory, use the file browser to change directories. To delete a setup from a different project, select the project from the Project box.

- 4 Click Delete.

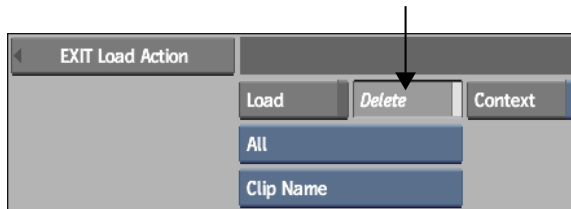

- 5 In the file browser, select the title (or proxy) of the item you want to delete.
A Confirm button appears in the menu.
- 6 Click Confirm or press **Enter** to confirm your selection.
The selected item is deleted from the directory and you are returned to the previous menu.

TIP To bypass the Confirm button when removing items, press **Alt** as you select an item to remove. To cancel the command, click elsewhere.

Deleting Multiple Items

To delete more than one item at a time, press **Ctrl+Alt** as you click the items you are deleting. Items are deleted with no Confirm message, and you remain in the Load menu. Click the Exit Load button to return to the previous menu.

Remaining in the File Browser

You can stay in the file browser by pressing and holding the **Ctrl** key when saving, loading, or removing items:

- When saving an item, press **Ctrl** as you click Save.
- When loading an item, press **Ctrl** as you click the item.
- When deleting items, press **Ctrl** as you click Confirm.

Setting the Default Preferences

In any module where preferences can be saved, you can save your preferences as the default so that they will be loaded each time you use the module. Each defined user can save default preferences. You can also return the default preferences to those that came with Flame.

The preferences directory is set to `/usr/discreet/<home>/correct/pref`. All the factory preferences are automatically copied to the new user. To change the default preferences directory, select `<new>` from the Preferences Directory box and use the file browser to create or select a new directory. See [Modifying a User](#) on page 548.

To save your preferences as the default:

- 1 In a module where preferences can be saved, set the preferences the way you want.
- 2 Display the Save menu.
- 3 Select Defaults from the Save option box. If the Confirm prompt appears, confirm the save.
The defaults are saved and you are returned to the previous menu.

To reset the defaults to the factory setting:

- 1 Display the Load menu.
- 2 Select Factory Defaults from the Load option box and Confirm.
The factory defaults are loaded, and you are returned to the previous menu.

NOTE When you load the factory defaults, the current default preferences are saved to a backup file that you can reload from the user's preference directory if needed.

Topics in this chapter:

- [About Clip History](#) on page 807
- [Modifying a Clip in its Last Module](#) on page 809
- [Modifying Clip History in Batch](#) on page 810
- [Managing Clips with Clip History](#) on page 813
- [Saving and Archiving Clips with Clip History](#) on page 818
- [Compatibility between Autodesk Products](#) on page 818
- [Clip History Functionality](#) on page 823
- [Clip History Features Per Product](#) on page 824

About Clip History

The Clip History feature tracks and updates operations you have applied to a clip or clip segment. It expands the clip, providing a view of your operations. To easily see all of a clip's operations, you can display the clip history in the Batch schematic. You can then use the clip history in Batch as an access point for modifying clips. You can modify a clip at any point in its history.

Clips that have a clip history contain sources and intermediates. Sources are any of the original clips used to build an effect, for example, clips captured using an EDL. Intermediates are clips that are created when building a clip that uses multiple effects or operations.

There are three ways that you can modify a clip using its clip history:

- The simplest way of using clip history is to load a processed clip back into the last module that was used to create the clip. For instance, you load a clip into the Colour Corrector, modify the colour, and process a new clip. You decide that you want to change the colour slightly, so you double-click the “H” icon of the new clip to go back into the Colour Corrector with the settings restored. You tweak the values slightly, and then process another clip (which has its own clip history).
- If multiple modules were used to create a clip, you can load them all into a Batch setup and make modifications at any point in the process tree. For instance, you may have created a composite by bringing a colour-corrected back layer into the Master Keyer with a front and key-in layer that may also have been modified (for example, with a Flip). By loading the resulting clip into Batch, you can modify it at any point in the process tree, and then process a new clip.
- If you edit together clips to create a clip with soft edits, and at least one of the clips has clip history, you can modify its segment in the Batch timeline. With this method, you access the Batch timeline, select the segment, and then expand it into a Batch process tree. You can then make changes to any of the nodes or clips. When outputting these modified clips, you have the choice of processing the entire clip, or a modified segment only.

If you expand a clip history with an Action module, only the Action media that contain clips with history will be expanded. Media without history are simply loaded as Action media.

Clips with history are indicated by the letter “H”. Edited soft clips with at least one segment with history are denoted by “h”.

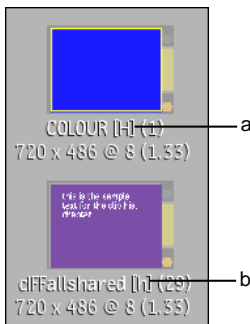

(a) Clip with history (b) Soft clip with history

NOTE For clip history to be created, you need to enable the Clip History preference in the Preferences menu.

Modifying a Clip in its Last Module

You can load a clip with clip history back into the most recent module that you used to process the clip. For instance, you bring clip A into the Colour Corrector, adjust its hue, and then process clip B. Clip B has clip history. You can double-click clip B's "H" icon to load it back into the Colour Corrector. The Colour Corrector opens displaying clip A and the corresponding adjustment to the hue value.

You can then make further adjustments to the colour values and process clip C, which in turn has its own clip history.

To edit the last operation applied to a clip on the desktop:

- 1 On the desktop, double-click the "H" icon of the clip you want to edit.

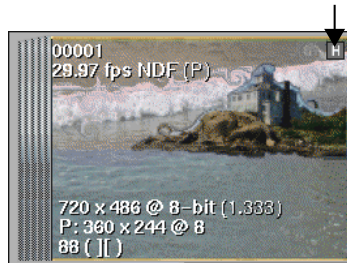

The menu corresponding to the last used module appears with the clips and parameters from the previous session.

- 2 Edit the module's settings as needed.
- 3 Click Process.
A new clip is created on the desktop with its own clip history.

Viewing Effect Information for Clips with History

You can view the name of the last module that was used to create a clip with history.

To view clip effect information:

- 1 Hold down **Alt** and then click the clip on the desktop.
The last used module name appears in the clip information.

Modifying Clip History in Batch

For some clips, you may have to modify their clip history in Batch. This is the case for any clip that you created using more than one effect or operation. To gain access to the original sources and effects settings, you expand the clip into a Batch process tree.

Also, if you edited clips together, and at least one of the clips has uncommitted clip history, you can only access that clip's history using the Batch timeline. The clip history for a segment can also be expanded into a Batch process tree.

Some nodes in a clip history tree appear as blank nodes. These wildcard nodes represent an effect that was applied to a clip that does not have an equivalent Batch node (Warper, for example). They are named after the module used to create them. You can disconnect or connect these nodes, but you cannot modify their values. They contain frames rendered at their position in the process tree.

Because wildcard node frames are rendered, changes made upstream do not propagate downstream. If you need to make upstream changes, you will have to recreate the effect. To do so, you exit Batch and rebuild the effect in the module originally used to create it.

NOTE If you flush the cache of a wildcard node, you lose the rendered frames, which results in a useless node. If you do this, you cannot process a new clip without first recreating the wildcard node effect outside of Batch and importing it to the process tree as a new clip.

Naming Nodes

When expanding a clip's history, a node will adopt the intermediate clip's name. For untitled clips, the node will take a generic name (CC4, for example). You can also manually name the nodes.

NOTE Names cannot begin with a space, #, or other special character.

To name a node:

- 1 In Batch, select the node that you want to name.
- 2 Select the Name field, type the new name, and then press **Enter**.



The node is renamed.

Expanding Clip History in Batch

You can load a clip with clip history into Batch to display a process tree that recreates the clip from its original sources, through all operations and effects, to its final output. You can then modify the process tree at any point. Once you have modified a clip, you can process it to create new clips, which, in turn, also have their own history.

To expand a clip's history in Batch:

- 1 From the Main menu, click Processing.
- 2 Click Batch, and then select a destination reel.
- 3 Click Setup, and then enable Fill with Intermediates.

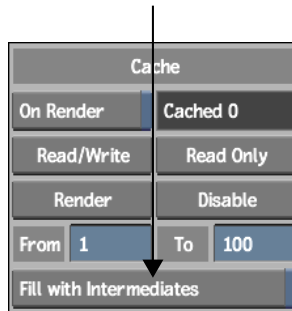

Each node's cache is filled with the intermediate clips contained in the history. Filling a Batch history tree's cache increases interaction speed and avoids the need to reprocess effects that were already rendered.

NOTE If an intermediate clip corresponding to a step in the history is deleted, the cache for that particular node is not filled.

- 4 Drag a Desk node to the Batch schematic.
The Desktop appears.
- 5 Select the clip with clip history and click Exit Clip Select.
- 6 Double-click the clip in the Batch schematic.
- 7 Click Basic.

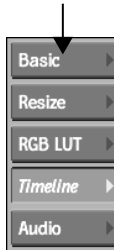

- 8 Do one of the following:

Click:	To expand:
Expand Hist	The entire clip history into a Batch process tree.
Expand One	The most recent step of the selected clip's history. If the input clip to the last node also contains history (denoted by "H" in the clip name), you can also expand the history for that clip.

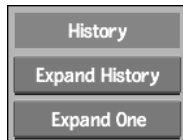

NOTE Using Expand One to display a clip's history will not display any Action media. If you want to expand the history of clips on any media, you have to convert the media into Batch Action media, and then expand the history for that clip.

- 9 Edit, add, or remove nodes, or connect and disconnect nodes and clips as you would in any Batch structure. See [Batch Processing](#) on page 1283.
- 10 Add an Output node to the process tree, set the processing options, and then click Process to render the Batch tree. See [Outputting and Exporting Batch Results](#) on page 1322.

The new clip is added to the specified destination. The original clip remains unchanged.

Managing Clips with Clip History

When creating clips with clip history, you can keep track of the sources used as well as the intermediates used to build the final clips.

Sources are any of the original clips that you use to build an effect, for example, clips that you captured using an EDL. Intermediates are clips that are created when building a clip that uses multiple effects or operations. For instance, you may need to resize or colour correct a clip before bringing it into the Keyer. The clip you process from the Keyer is the final clip, but the clip processed from the Resize module is an intermediate.

There are a number of tools you can use to keep track of the sources and intermediates used. Use the Search tool to find clips with history or clips that were used to create a clip with history. Use the Delete tool to delete sources or intermediates for a selected clip with clip history. Use the Commit tool to commit a clip with history just as you would any other clip.

Managing Sources and Intermediates

When working with a clip's history, you can use one of three options: Keep Intermediates and Sources, Keep Sources, or Keep None. When you use Keep Intermediates and Sources, source and intermediate clips are embedded inside the clip history. This means that the frames used in the clip history are stored even if the intermediate clip (on the desktop or in the clip library) is deleted. If this option is not selected, frames referenced by the clip history are deleted when the intermediate clip is deleted.

When you use the Keep Sources option, sources are embedded in the resulting clip with clip history but intermediates are not. Intermediates will no longer be available for clip history if you delete them. When intermediate clips are not available (either in the resulting clip with clip history, on the desktop, or in the library), you cannot modify the clip's history using the Expand One button in Batch —intermediates are needed with this option. Instead, you use the Expand History button in Batch to expand the entire clip history back to the source clips. With Expand History, you modify the nodes corresponding to the intermediate processes rather than the intermediates themselves. See [Expanding Clip History in Batch](#) on page 811.

NOTE If you use Modular Keyer, Compositor, Paint, the Warper, or the Stabilizer to create an intermediate, you must save and archive the resulting clip because it is needed when you expand clip history in Batch.

When you use the Keep None option, neither source nor intermediate clips are embedded in clip history. See [History](#) on page 837.

WARNING If the sources are no longer available to recreate clips with history, you will have to recapture these sources in order to edit the history of any clips using them.

Searching for Clips with History

You can search for clips with history on the Desktop or in the clip library. The Search tool provides an easy way to organize clip history sources and intermediates.

To search for clips with history:

- 1 From the desktop, click Search.

The Search controls appear.

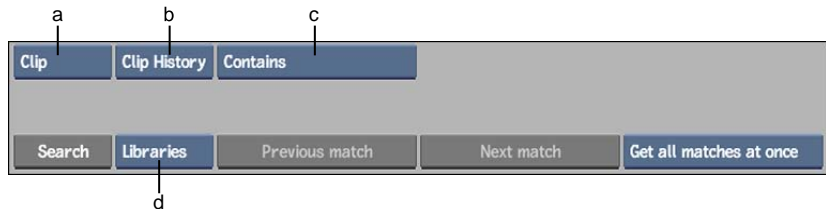

(a) Search Mode box (b) Match Criteria box (c) Clip History Search options
(d) Range box

- 2 In the Search Mode box, select Clip.
- 3 In the Match Criteria box, select Clip History.
- 4 In the Clip History Search option box, select one of the following.

Select:	To:
Contains	Search for clips that contain clip history.
Does Not Contain	Search for clips that do not contain clip history.

Select:	To:
Sources	Search for sources that were used in a selected clip's history.
Intermediates	Search for intermediates that were used in a selected clip's history.
Intermediates + Src	Search for sources and intermediates that were used in a selected clip's history.

- 5 In the Range box, select Desktop or Library.
- 6 Click Search, and then select a clip (if needed).

NOTE You need to select a clip when searching for sources or intermediates.

A message appears in the message bar indicating if any matches were found.

- 7 If there are matches, click a destination reel.
The matched clips are moved (if found on the desktop) or loaded (if found in the clip library) to the destination reel.

Deleting Sources and Intermediates

When you want to free up disk space or shorten the time it takes to perform a wire transfer or archive clips that have clip history, you can delete the sources or intermediates used to create the final processed clip. To delete intermediates that are used in multiple clips with clip history, you must delete them from all clips at the same time. You can do this from the Desktop or a clip library.

To delete sources or intermediates from the desktop:

- 1 In the Main menu, click Library.
- 2 Click Delete.
The Delete controls appear.

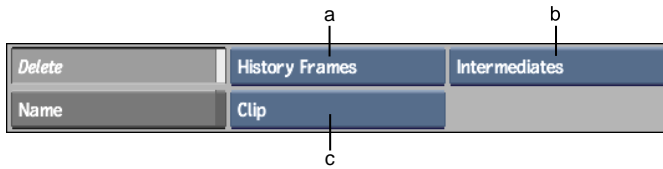

(a) Delete option box (b) Delete History options (c) Delete Mode box

- 3 From the Delete option box, select History Frames.
- 4 Select an option from the Delete History option box corresponding to what you want to delete.

Select:	To:
Intermediates	Delete the intermediates used to create a selected clip.
Intermediates + Src	Delete the intermediates and sources used to create a selected clip.

- 5 From the Delete Mode box, select Clip, Reel, or Desktop.
 - If you select Desktop, you are prompted to confirm the deletion.
 - If you select Clip or Reel, you have to select the clip or reel to delete.

The sources or intermediates are deleted.

To delete sources or intermediates in a clip library:

- 1 In the clip library, click Tools.
- 2 From the Tools menu, select Consolidate.
The Consolidate controls appear.



(a) Delete History option box

- 3 Select an option from the Delete History option box.

Select:	To:
Intermediates	Delete the intermediates used to create a selected clip.
Intermediates + Src	Delete the intermediates and sources used to create a selected clip.

- 4 Click Delete History Frames.

Committing a Clip with History

You can commit a clip with a history, or a clip segment with a history just as you would any other clip. When doing so, you delete the clip history without removing the clip or segment's soft properties.

To commit a clip's history:

- 1 In the Main menu, click Editing.
- 2 Click Commit, and then select History from the Commit Type box.

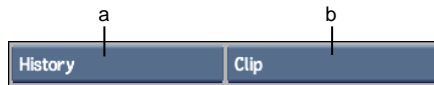

(a) Commit Type box (b) Commit Mode box

NOTE You can also commit using the Clip option. This commits both the history and the edits.

- 3 From the Commit Mode box, select whether you want to commit a clip, reel, or the entire desktop.
- 4 Click the clip with history that you want to commit.
The clip's history is committed.

Saving and Archiving Clips with Clip History

All clips are saved with their histories and setups embedded into them. A saved clip history includes the following attributes and parameters, which are available when a clip is restored:

- References to input clips
- Module names
- Setups

In most cases, you only need to save and archive original sources and the result clip when you save and archive clips with clip history. However, if you use an Autodesk Visual Effects and Finishing product to create an intermediate using Motion Estimation, Modular Keyer, Compositor, Paint, the Warper, or the Stabilizer, you must save and archive the resulting intermediate because it is needed to expand clip history.

Any clips in a library that have clip history are automatically saved or archived along with their history. Clip history media is stored on the media storage volume and metadata is stored on the system drive. If, for any reason, you need to access the metadata files, you can find them in the following folders:

- *usr/discreet/clip/<framestore volume>/<project name>/history*
- *usr/discreet/clip/<framestore volume>/<project name>/effects_history*
- *usr/discreet/clip/<framestore volume>/<project name>/<library name>_history*

Compatibility between Autodesk Products

Because clip history provides a record of most operations performed during a project, project collaboration is facilitated. Multiple users can work on a single clip and then use the clip history to navigate through changes made to a clip.

For instance, an Inferno, Flame, or Flint user could create a clip that included a colour correction and text effects. A Smoke user could then open the clip in Smoke on the EditDesk or in the Batch module, expand the history, and go directly to colour correction or text changes to make further modifications, regardless of the order in which the effects were created. The Inferno, Flame,

or Flint user could also open the modified clip and use the clip history as a navigation tool in the same way.

The Clip History feature exists in Inferno 6.0, Flame 9.0, and Flint 9.0 or later, and in Smoke 7.0 and Backdraft Conform 7.0 or later. In Smoke and Backdraft Conform, you can view clip history that was created in Inferno, Flame, or Flint and vice versa. However, there are limitations to what you can access.

You cannot access certain modules created in Inferno, Flint, or Flame when you are in Smoke or Backdraft Conform. For example, if you view clip history in Smoke that contains a Compositor module (a module in Inferno, Flame, and Flint but not in Smoke), you cannot open the Compositor module from the Smoke clip history. Additionally, you cannot access any module in the history that precedes an unsupported module. Using the same example, if a cross-product-compatible module such as the Colour Corrector appeared in the clip history before the Compositor module, you would not be able to access the Colour Corrector module from the clip history in Smoke. You cannot change the order of modules, add modules, or delete modules in the clip history in Smoke and Backdraft Conform.

The following sections contain some basic clip history examples.

For a complete list of clip history support based on product and feature, see [Clip History Features Per Product](#) on page 824.

Viewing Clip History from Smoke

The following sections illustrate clip histories that were created in Inferno, Flame, and Flint.

All Modules Supported in Smoke

The following illustration shows the original clip history as it appears in Inferno, Flame, and Flint.

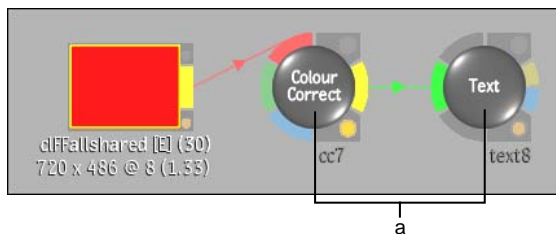

(a) Clip history in Inferno, Flame, and Flint

Smoke supports both the Colour Corrector and Text modules. Therefore, the clip history in Smoke has an icon for both the Colour Corrector and Text modules. You can access both modules from the clip history in Smoke.

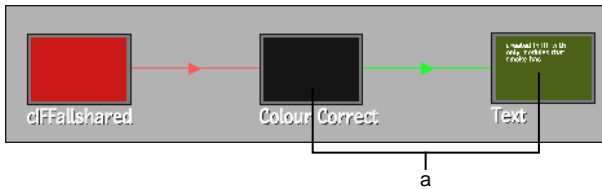

(a) Corresponding clip history in Smoke

Some Modules Supported in Smoke

The following clip was processed in the Colour Corrector. It was then processed in the Batch Module using the Average node. The resulting clip was processed in the desktop Text module.

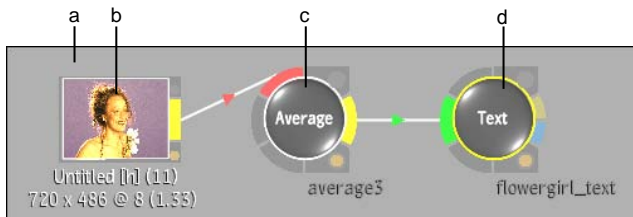

(a) Clip history in Inferno, Flame, and Flint (b) Clip with colour correction, supported in all products (c) Batch module operations supported in Inferno, Flame, and Flint only (d) Text supported in all products

Smoke supports the Colour Corrector and Text, but not the Batch module. The Colour Corrector is supported in Smoke, but it is not accessible because it precedes an unsupported module. An unsupported module blocks access to all previous modules in the clip history.

Smoke provides access to only the Text module. The grey icons act as placeholders in Smoke for the inaccessible portion of the clip history.

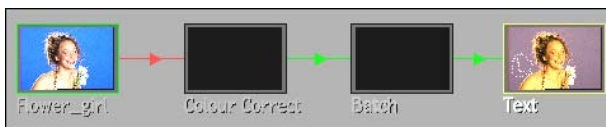

Batch icon stands as a placeholder for inaccessible clip history in Smoke

Viewing Clip History in Inferno, Flame, and Flint

The following sections illustrate clip histories that were created in Smoke.

All Modules Supported in Inferno, Flame and Flint

The following illustration shows the original clip history as it appears in Smoke.

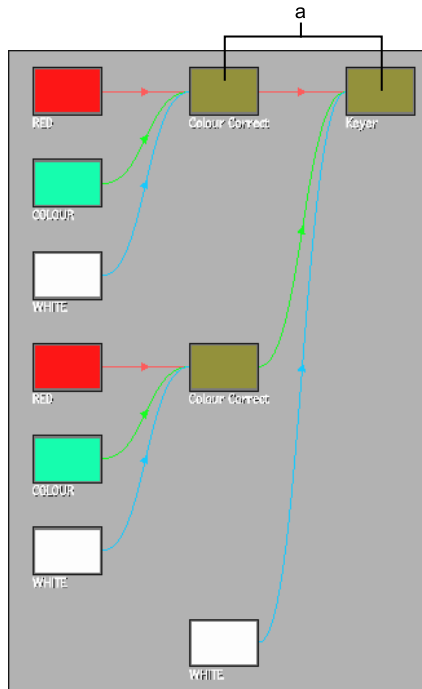

(a) Clip history in Smoke

Inferno, Flame and Flint support all modules created in Smoke. Therefore, the clip history in Inferno, Flame and Flint has a node for both the Colour Corrector and Keyer modules.

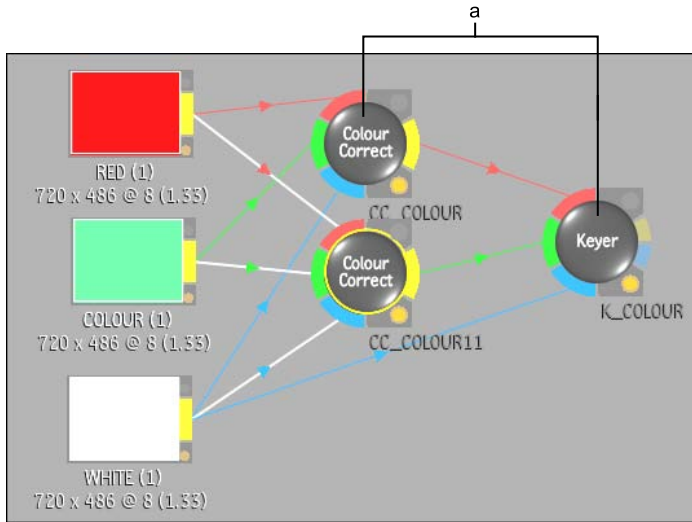

(a) Corresponding clip history in Inferno, Flame, and Flint

No Soft Effects Supported in Inferno, Flame, and Flint

The following illustration shows the original clip history in Smoke.

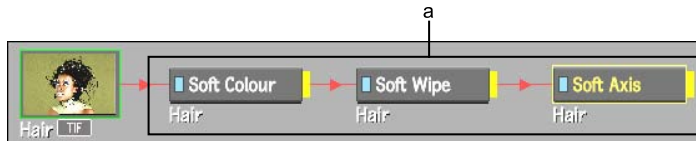

(a) Soft effects supported only in Smoke

Image courtesy of The House

Inferno, Flame and Flint do not support any soft effects in clip history. Therefore, when you bring the clip history into Inferno, Flame or Flint, you only see a placeholder icon representing the clip. This icon does not provide access to soft effects. You can modify soft effect using the clip's timeline.

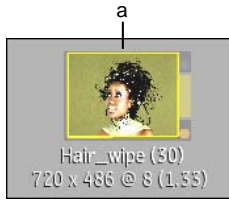

(a) Icon stands as placeholder for inaccessible clip history in Inferno, Flame, and Flint

Clip History Functionality

When using clip history, the following limitations apply:

- If you expand a clip with an Action module or node in Smoke, only features that are already available in Smoke are editable. If the clip is reopened in Inferno, Flame, or Flint, the features accessible in these products will be retained.
- If you have a Paint or Stabilizer element in your clip history, all modules that precede the Paint or Stabilizer module will not be editable. You can, however, modify the elements before the Paint or Stabilizer element by selecting the element immediately preceding the Paint or Stabilizer element in the history, and then pressing the **Match** hotkey to create a clip with the same history in the Source Area. You can then use the result clip from the match. The history is expandable and editable.
- The duration of a clip created in the Paint module is not retained. For example, enter the Paint module with None selected, and then in the Paint module create a scene that is 30 frames. Then go into a module such as Action and make some changes. When you view the clip history and click the Paint module element, the clip will contain one frame only.
- When you enter a module from clip history, in and out points mark the duration in the source clip that was used in the clip history (unless the entire clip was used). If you then make a modification and process the result, only the duration of the clip marked by in and out points is rendered, unless you park the cursor before the in point. If the cursor is parked before the in point, media is added to the head frames, starting from the cursor position.
- Always apply soft effects or Batch FX after you work in modules if you want to edit the soft effects from the clip history. If you process a clip in a module after a soft effect has been added to the clip history, you can no longer modify the preceding clip history. The clip name is also greyed out

to indicate that the preceding soft effects and modules are no longer editable. For example, if you add a timewarp to a clip and then go into the Colour Corrector module and process the clip, you will not be able to edit the timewarp in the History view. The timewarp will be greyed out in the clip history.

- When you process a clip or element starting at a frame other than the first, the leading unprocessed frames are padded with unrendered frames. Unrendered frames are put in the header of the clip, producing a soft clip with a specific number of heads. This is necessary in Inferno, Flame, and Flint so that when you expand clip history in Batch, the frame numbers match between all nodes in the Batch schematic. It is also necessary in Smoke so that you can trim the element and then access the clip history to render the missing media.

Clip History Features Per Product

The following tables summarize the modules that are accessible in the clip history by product. The features are listed in alphabetical order.

Clip History Accessibility

The following table summarizes the differences in module accessibility when a segment's history is expanded on the EditDesk in Smoke or Backdraft Conform, and in Batch in Inferno, Flame, or Flint. Certain modules have limited accessibility. See [Clip History Functionality](#) on page 823.

Feature	Inferno and Flame	Flint	Smoke	Backdraft Conform
Action	Yes	Yes	Yes	No
Auto Matte	Yes	Yes	Yes	No
Average	Yes	Yes	Yes	No
Burn-In Letterbox	Yes	Yes	Yes	No
Colour Corrector	Yes	Yes	Yes	No
Colour Warper™	Yes	Yes	Yes	No
Combine	Yes	Yes	Yes	No

Feature	Inferno and Flame	Flint	Smoke	Backdraft Conform
Compositor	Yes	Yes	No	No
Compound	Yes	Yes	Yes	No
Degrain	Yes	Yes	Yes	No
Difference	Yes	Yes	Yes	No
Distort	Yes	Yes	No	No
Filter	Yes	Yes	Yes	No
Flip	Yes	Yes	Yes	No
Keyer	Yes	Yes	Yes	No
Logic Ops	Yes	Yes	Yes	No
Modular Keyer	Yes	No	No	No
Negative	Yes	Yes	Yes	No
Optics	Yes	Yes	Yes	No
Paint	Yes	Yes	Yes	No
Posterise	Yes	Yes	Yes	No
Quick Composite	Yes	Yes	No	No
Regrain	Yes	Yes	Yes	No
Separate	Yes	Yes	Yes	No
Sparks®	Yes	Yes	Yes	No
Stabilizer	Yes	Yes	Yes	No
Text	Yes	Yes	Yes	No
Warper	Yes	Yes	No	No

Clip History Accessibility in Batch

The following table summarizes the differences in accessibility of Batch nodes in a segment's history by product. Certain nodes have limited accessibility. See [Clip History Functionality](#) on page 823.

Batch Node	Inferno and Flame	Flint	Smoke
3D Keyer	Yes	No	No
Action	Yes	Yes	Limited
Auto Stabilize	Yes	No	No
Distort	Yes	Yes	No
Glow	Yes	No	No
Lens Distort	Yes	Yes	No
Modular Keyer	Yes	No	No
Motion Analysis	Yes	Yes	No
Motion Blur	Yes	Yes	No
Vector Viewer	Yes	Yes	No

Setting Preferences

33

Topics in this chapter:

- [About Preferences](#) on page 827
- [Accessing the Preferences Menu](#) on page 828
- [Project Management Preferences](#) on page 828
- [Preview Preferences](#) on page 829
- [Pointer Preferences](#) on page 830
- [User Interface Preferences](#) on page 831
- [Documentation Preferences](#) on page 834
- [Tooltips Preferences](#) on page 835
- [Miscellaneous Preferences](#) on page 835
- [General Preferences](#) on page 836
- [Timeline Preferences](#) on page 841
- [Desktop Preferences](#) on page 848
- [Audio Preferences](#) on page 853
- [Storage Preferences](#) on page 860
- [LUT Preferences](#) on page 861

About Preferences

Use the Preferences menu to set up your work environment. Preferences that you set in the Preferences menu are either global preferences that apply no matter where you are in the application, or that are shared in two or more areas.

Preference settings are maintained from session to session for each user. For information on saving preferences, see [Saving Setups and Preferences](#) on page 799.

Accessing the Preferences Menu

Access the Preferences menu directly from the Desktop.

To access the Preferences menu:

- 1 Click Preferences on the Desktop.

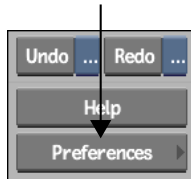

TIP You can also access the Preferences menu from anywhere in the application using the hot key **Ctrl+Alt+F6**. Depending on where you access the Preferences menu, some preferences may not be available to change.

- 2 To exit the Preferences menu, click EXIT Preferences or use the hot key **Ctrl+Alt+F6** to return to the previous menu.

Project Management Preferences

The Project Management preferences allow you to monitor or change the current project and user settings.



In this section of the Preferences menu, you can:

- Switch to a different project by selecting one from the Project box and clicking Load.

TIP Use the Sort box to sort the project list by name, date, or resolution.

- Switch to a different user by selecting one from the User box and clicking Load.
- Edit a project's settings by selecting one from the Project box and clicking Edit.
- Edit a user's settings by selecting one from the User box and clicking Edit.
- Create projects by selecting <new> from the Project box.
- Create users by selecting <new> from the User box.

See [Managing Projects and Users](#) on page 521.

NOTE When accessing the Preferences menu with the hot key **Ctrl+Alt+F6** from anywhere in the application other than the Desktop or the Clip Library, you are not able to edit the project's settings.

Preview Preferences

The Preview preferences allow you to change video timing and set your broadcast monitor settings.

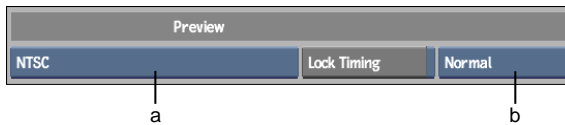

(a) Video Timing box (b) Broadcast Monitor box

Video I/O Timing Preferences

In the Video Timing box, you can set the video I/O timing to correspond to the video standard defined by the selected project's configuration file or another video standard.

It is a good idea to edit the software initialisation configuration file (by default, *init.cfg*) to uncomment all VTRs that you expect to use over the course of your project (or you can uncomment all VTRs). The video I/O timing setting for each session automatically ignores incompatible VTR devices. You can also lock the timing selection to the timing of the current project when switching between projects.

NOTE If the Video keyword is disabled in the software initialization configuration file, No Preview appears in the Video Timing box.

Broadcast Monitor Preferences

Use the Broadcast Monitor box to specify what you want to preview on your broadcast monitor.

Select:	To display:
Normal	The contents of an image viewer or Player.
Always ON	Whatever is displayed on your graphics monitor.
Always OFF	Nothing on the broadcast monitor.

This setting can be changed on-the-fly while you are working in Flame.

Pointer Preferences

You can adjust the sensitivity of the pen and other pointer preferences.

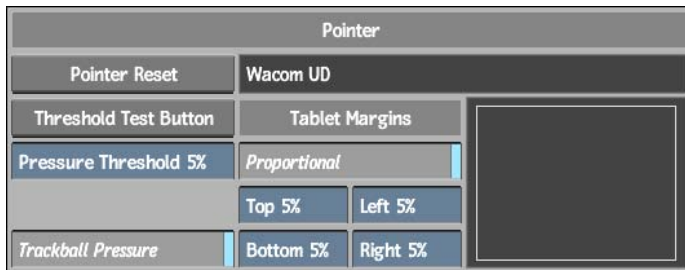

If you are using a mouse, or if the pen failed to initialise on start-up, the items in this menu do not appear. Instead, you see a fixed field indicating that you are in Mouse mode. To re-initialise the pen, press **Shift+T+Insert**.

Pointer Reset button Returns all pointer preferences to their default values.

Tablet Model box Displays the model of the currently installed tablet.

Threshold Test button Assesses the sensitivity of the pen interactively. Press the pen on the button and a sliding grey bar in the message bar displays the response to the amount of pressure applied.

Pressure Threshold field Sets the amount of pressure that you want to apply when using the pen. Use a higher value to decrease the sensitivity of the pen (more pressure required). A value of 5 works well.

Trackball Pressure Determines whether the trackballs respond to changes in the pressure applied when using the stylus. When enabled, increase pressure on a trackball to create a greater (faster) change; decrease pressure to create a more refined (slower) change.

Jitter Filter field Adjusts the amount of jitter if you are using an Intuos tablet (Wacom® GD- series). The cursor may jitter when the tablet is close to a source of magnetic fields, such as your monitor. You can adjust the Jitter Filter setting of the pen to compensate for this unwanted jitter. This value represents the minimal amount of pen movement needed to report a new coordinate on the screen.

Tablet Margins controls Adjust the left, right, top, and bottom boundary of the active area on the tablet. Use the Proportional button to make these four values change proportionally.

User Interface Preferences

The User Interface menu provides access to custom menu setups, and user interface settings.

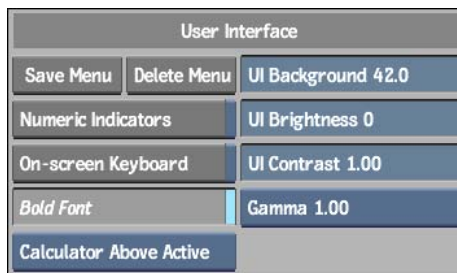

Numeric Indicators Use the Numeric Indicators button to enable or disable value indicators on numeric fields. See [Numeric Fields](#) on page 37.

On-screen Keyboard When you enter text in a field, you can choose to have the on-screen keyboard appear or just have editing access to the field. To use the on-screen keyboard, enable On-Screen Keyboard.

TIP You can also turn the keyboard on or off anywhere in Flame by pressing **Ctrl+Alt+K**.

Bold Font Toggle bold font for text on buttons on and off.

TIP You can also toggle the bold font on or off anywhere in Flame by pressing **Ctrl+Alt+B**.

Calculator Placement box The calculator appears when you click in a numeric field. Use the Calculator Placement box to determine where the calculator will appear.

Select:	To open the calculator:
Calculator Free Floating	In its most recent location.
Calculator Lower Right	In the lower-right corner of the user interface.
Calculator Beside Active	Right or left of the active numeric field.
Calculator Above Active	Above the active numeric field.

To move the calculator to a new location, click and drag on the top edge of the calculator. If Calculator Free Floating is selected, the calculator will open in the new location the next time a numeric field is activated.

UI Background Adjust the background brightness. 0 = black and 100 = white. The default value is 18. A darker background is suggested for film work, and a lighter background is suggested for video work.

UI Brightness Adjust the brightness of interface elements such as buttons and fields. The default value is 0. The image window, image proxies, and background are not affected by the UI Brightness setting.

UI Contrast Adjust the contrast of interface elements such as buttons and fields. The default value is 1.0. The image window, image proxies, and background are not affected by the UI Contrast settings.

Gamma Set the system gamma. The options in this box are defined by the Gamma keyword of the *init.cfg* configuration file.

Creating Custom Menus

You can create a custom menu setup by changing the size and location of buttons, fields, and boxes on the interface using the User Interface menu.

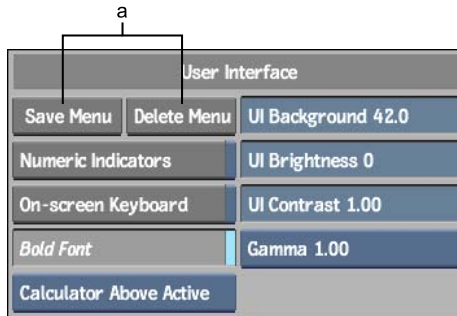

(a) Custom menu options

All interface items are aligned on a grid. To display the grid on the screen, press **Ctrl+Alt+F9**. Press **Ctrl+Alt+F9** a second time to hide the grid.

To select an interface item, click it using the left mouse button. To select a group of interface items, press and hold the **Ctrl** key while clicking each. Drag the control handles that appear on the selected items to change their size. To move a selected item, press and hold on the item and drag it to the desired location. To reposition the button title text, click the button with the centre mouse button and drag the text to the desired location.

WARNING There are a number of hidden buttons in the menus. Do not alter these buttons as you may affect the functionality of Flame.

Saving a Custom Menu Setup

After modifying the menu setup, you can save your custom setup to use in later work sessions.

To save a custom menu setup:

- 1 Make changes to the default menus in any location in Flame.
- 2 Open the Preferences menu (**Ctrl+Alt+F6**).
- 3 In the User Interface section, click Save Menu.
The file browser appears.
- 4 Click in the Filename field next to the Save button, enter a name for your menu setup files, and press **Enter**. (It is not necessary to specify a filename extension.)
The custom menu setup is saved.

Removing a Custom Menu Setup

You can remove custom menu setups that you no longer need.

To remove a custom menu setup:

- 1 In the User Interface menu, click Delete Menu.
The file browser appears.
- 2 Select the menu setup you want to remove.
- 3 Click the Confirm button that appears to remove the setup and return to the Preferences menu.

Loading a Custom Menu Setup

If you want to load a custom menu setup, you must do so when you start Flame.

To start Flame with a custom menu setup:

- 1 At the command line, type:
Flame -f <filename>
where <filename> is the name of the custom menu setup. (It is not necessary to specify a filename extension.)

Documentation Preferences

You can access PDF and HTML versions of the documentation for Flame.

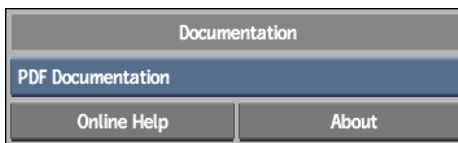

PDF Documentation Select a PDF document to open from the list.

Online Help Open the online help in a browser.

TIP You can also use the hot key **Ctrl+=** to display the online help from anywhere in the application.

About button Click to display licensing and copyright information about Flame.

Tooltips Preferences

Use the Tooltips preferences to set how tooltips are displayed. Tooltips display the keyboard shortcut and a brief description for objects (such as buttons and fields) on the user interface.

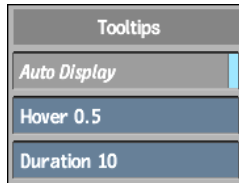

Auto Display button Enable or disable automatic tooltip display. If you disable automatic display of tooltips, you can still display them for selected buttons using the hot key **Ctrl+Alt+Spacebar**.

Hover field Change the amount of time you must position the mouse over the object before the tooltip displays (in seconds).

Duration field Change the amount of time that the tooltip is visible (in seconds).

Miscellaneous Preferences

Use these preferences to access the message history log and the Hot Key Editor.



Message History button Click (or press **Ctrl+Alt+F7** from anywhere in the application) to access a log of system messages at any time during the current session. If a message disappears too quickly from the message bar, you can view it from the message history log.

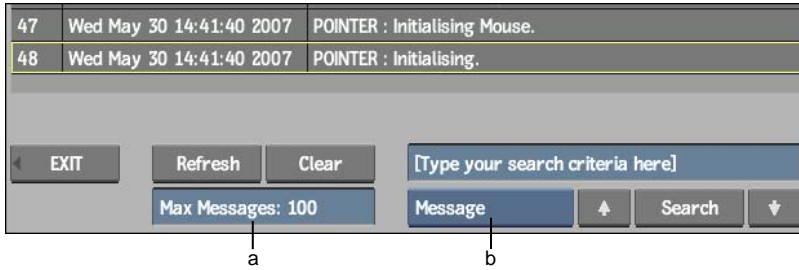

(a) Message Number field (b) Search Criteria box

The most recent message appears as message 1 in the # column. You can re-sort most of the columns by clicking the column heading. Identical and similar messages are identified in the Repeated column. You can set the number of messages saved, refresh or clear the message history, and do specific searches.

To search the message history log:

- 1 Set the search criteria. You can search by Message or Source keywords.
- 2 Enter your keywords in the Argument field.
- 3 Click Search.

All instances of your search are highlighted. Use the arrow keys to scroll through the results.

Hotkey Editor Click to enter the Hot Key Editor. For information on using the Hot Key Editor, see [Managing Hot Keys](#) on page 863.

General Preferences

Use the General preferences to control clip information, clip loading, clip history, dual timecode display, and setup scaling.

General

Display the project framerate.



Project Framerate box A locked field that display the framerate that correspond with the current project's default resolution.

Modules

These settings display the scan format and setup scaling.

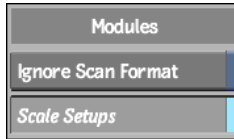

Ignore Scan Format button Enable the Ignore Scan Format button to:

- Ignore scan mode when determining whether or not a clip matches the project's default resolution. (For example, if you have a progressive NTSC-sized clip in an NTSC project, the clip's information will not appear cyan.)
- Disable warnings that are usually given when you load clips with different scan modes into a module.
- In Action, set all media to Progressive no matter what scan mode is used by the source clips.
- In Action and Batch, disregard scan mode when detecting mismatching resolutions.

Scale Setups button You can load setups (such as Text setups, Keyer setups, and colour correction setups) that were created in a resolution different from that of your current project. For the setups to work correctly in your current project, you must scale them when you load them. To scale setups when loading them, enable the Scale Setups button.

History

Use these preferences to enable or disable clip history.



Clip History button Enable to include a history of all operations performed on your clips. See [Clip History](#) on page 807.

Keep History Mode box Determines whether Sources or Intermediates and Sources appear on the desktop when working with clip history.

Select:	To:
Keep Sources	Keep only the sources (clips without a history).
Keep Intermediates + Src	Keep both sources and references to all intermediate clips.
Keep None	Not keep any frames. If the intermediates or sources are deleted from the desktop, they will be unavailable for the clip history as well.

Batch Editing

Use these preferences for saving source clips from Batch. See [Managing Edited Clips in Batch](#) on page 1188.



Untitled Clip Name

Set how untitled clip names are displayed in Flame.

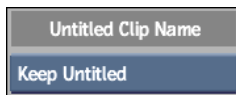

Untitled Clip Name box Use an automatic timestamp to rename untitled clips to make it easier to distinguish multiple <Untitled> clips.

Select:	To name your clip:
Keep Untitled	<Untitled>
Use Date & Time	yyyy/mm/dd hh:mm
Use Date	yyyy/mm/dd
Use Time	hh:mm

After you set this preference, any new untitled clips are renamed according to your selection.

NOTE When exporting a clip with a timestamp name, all unsupported characters (/, :, and spaces) are replaced by underscores.

Autosave

Use the Autosave fields to specify how often all clips currently loaded on the Desktop are saved. If your work session terminates due to a software or hardware failure, you can recover all the work done up to the last time an autosave was performed.

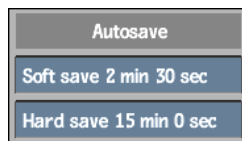

Soft Save field Set the time until a soft autosave performs. A small red icon appears indicating a two second delay before a soft autosave occurs. To abort this autosave, move anywhere within the application (in this case, the next autosave occurs at the interval you set in the Soft save field). The maximum interval is 30 minutes 0 seconds. The default value is 2 minutes 30 seconds. Enter a value of 0 minutes 0 seconds to disable the Autosave function.

Hard Save field Set the time until a hard autosave performs. A hard autosave occurs at the specified time regardless of any user intervention. If a soft autosave occurs, the hard autosave is also reset. The minimum interval for the hard autosave is the same as the time you enter for the soft autosave (in this case only hard autosaves occur). The maximum interval is 30 minutes 0

seconds. The default value is 15 minutes 0 seconds. Enter a value of 0 minutes 0 seconds to disable the Autosave function.

Undo

Use the Undo Levels field to specify how many levels of information are saved to the undo buffer (the default is 10 levels). This value determines the maximum number of actions you can undo when working on the Desktop. For example, if the Undo Levels value is set at 5 and you delete 6 clips from the Desktop, you can click Undo once for every clip you want to restore to the Desktop, except the first one. Since the Undo Levels value is set to 5, the first deleted file cannot be restored.

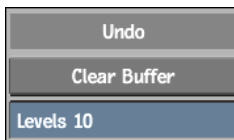

When you delete clips from the Desktop, they are temporarily stored in the undo buffer and occupy space in the framestore. To remove the clips from the undo buffer and free up disk space on the framestore, use Clear Buffer.

Burn Update Interval

Enter a value to set the interval between which the Burn background rendering queue is checked.



NOTE This option appears only if Burn is installed on your system.

Animation

Use the Animation area to set the default interpolation and extrapolation modes for setting keyframes. See [Setting Interpolation](#) on page 1980 and [Setting Extrapolation](#) on page 1983.

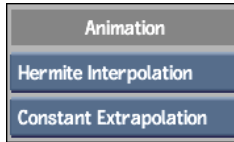

Default Interpolation box Set the default interpolation type to be Constant, Linear, Hermite, or Natural.

Default Extrapolation box Set the default extrapolation type to be Constant, Linear, Cycle, or Rev/Cycle.

Timeline Preferences

Use the preferences in the Timeline tab to customize the behaviour of various timeline controls and to control the information displayed on timeline elements.

Timeline

Set preferences for the Batch timeline.

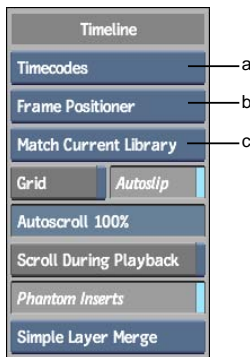

(a) Clip Information box (b) Frame Positioner box (c) Match box

Clip Information box Use to display either timecodes or frame numbers in the frame marking controls, on the scrub bar, on segments, and in the Duration and Current fields below the timeline.

TIP Press **Shift+T** to toggle between timecodes and frame numbers from the timeline.

Frame Positioner box You can set how the timeline positioner behaves when moved. When the Frame Positioner option is selected, the timeline positioner snaps from frame to frame as it is moved. When the Sub-frame Positioner option is selected, the timeline positioner snaps on a sub-frame (one-tenth of a frame) basis. Use the Sub-frame Positioner setting for sub-frame editing of audio tracks.

Match box Use the Match options to set the location where the application searches for source clips when matching timeline elements.

Select:	To look:
Match All Libraries	In all clip libraries for the matching source clip.
Match Current Library	In the current clip library for the matching source clip.
Match Segment	In the clip history for the matching source clip. (The application keeps a history of all clips used to create clips and edit sequences and always finds a source clip in an edit sequence's history.)

Grid button Use to control the display of grid lines on the timeline:

- When this button is enabled, a grid line appears at every frame (except when zooming out to a point where the display does not permit that level of detail).
- When this button is disabled, a grid line appears at every frame, 10 frames, second, 10 seconds, or minute, depending on the horizontal zoom setting.

Grid lines are for visual reference only—they do not affect segments in any way.

Autoslip button Use to control the frame numbering of material that you copy, extract, or lift from the timeline to the Batch schematic. Autoslip affects these edits when they are performed gesturally and with hot keys.

- Enable Autoslip to maintain the frame numbering of the frames in the original segment. For example, if you extract frames 5 to 10, the extracted, copied, or lifted material starts at frame 5, and the new clip has a slip value of -4. The slip value is displayed in the Basic menu, and you can modify it if needed.
- Disable Autoslip to start the extracted, copied, or lifted material at frame 1.

NOTE Matched segments are not autoslipped.

Auto Scroll field When you gesturally try to move a segment past the displayed timeline area, the timeline scrolls to accommodate the move. Use this preference to set the speed at which the timeline scrolls. The default speed is 100%.

Scroll During Playback button Enable to scroll the timeline during playback to keep the frame positioner visible.

Phantom Inserts button Enable to see a pink preview of a segment when you insert edits on the timeline, so you can preview where your edit will go (enabled by default).

Merge Layers Mode box Defines how a timeline will be 'flattened' when using the Merge Layers tool. This tool is used to create a one-layer version of a multilayer video track.

Select:	To merge layers by:
Simple Layer Merge	Hard committing all soft transitions. Cut points between elements are preserved; clip handles are not.
Complex Layer Merge	Hard committing soft transitions but creating separate elements with clip handles for each.
Committed Layer Merge	Preserving editable soft transitions and clip handles.

Timewarp

Set the following preferences for working with timewarps.

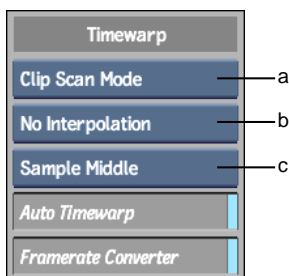

(a) Timewarp Render Mode box (b) Interpolation option box (c) Timewarp Sample box

Timewarp Render Mode box Set the render mode you want to use when you add a timewarp to a clip. You can select Interlaced, Progressive, or Clip Scan Mode. In Clip Scan Mode, Flame automatically sets the render mode to that of the clip (either progressive or interlaced).

Interpolation option box If you create an interlaced timewarp, select from the following interpolation options.

Select:	To:
No Interpolation	Create a timewarp with no field interpolation.
Half Interpolation	Create a timewarp in which interpolation only takes place on displaced fields.
Full Interpolation	Create a timewarp in which all fields are interpolated. Note that this option has the least aliasing, but you may notice some softening of the image due to the blending of the fields.
Shift Field Up	Shift the image up by a single line. This may help reduce artifacts that appear in reverse timewarps of 100%.
Shift Field Down	Shift the image down by a single line. This may help reduce artifacts that appear in reverse timewarps of 100%.

Timewarp Sample box Select whether the sampling of the timewarp will be done at the beginning, middle, or end of the timing curve for each frame or field. You can also change the Timewarp Sample option in the Timewarp Editor to override the default.

Select:	To sample the timewarp:
Sample Start	At the start of the frame.
Sample Middle	(Default) At the middle of the first frame. Generally, you should use this setting. Depending on the timewarp speed and how other editing systems create timewarps, you may need to change the sampling to fit what was done elsewhere.
Sample End	At the end of the frame.

Auto Timewarp button This option allows you to specify the behaviour of four-point replace and overwrite edits when they involve a differing number of frames between the in and out points on the source and record clips. These types of edits require that the record duration does not change.

Enable Auto Timewarp if you want to timewarp the inserted frames from the source clip. The actual frames between the in and out points on the source clip are used. See [Working with Implicit Timewarps in Batch](#) on page 1162.

Disable Auto Timewarp if you want excess source clip frames to be added to the edit as tail frames. The source clip selection begins at the in point, but if the length of the source selection exceeds the record selection, excess frames at the end of the source selection are not used. Instead, the excess frames are added as tail frames. If the length of the source selection is less than the record selection, the source selection overwrites the equivalent number of frames in the record clip. Essentially, a four-point edit is treated as a three-point edit.

Auto Timewarp is enabled by default.

Framerate Converter button Enable to format the source clip to the correct destination framerate by applying a video timewarp to the source clip.

Dissolve

Use these preferences when using dissolves.

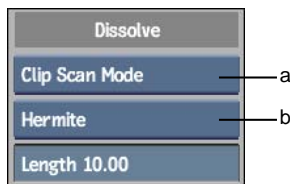

(a) Dissolve Render Mode box (b) Curve Type box

Dissolve Render Mode box Use to set the default rendering type for dissolves created in the timeline. Note that you can change this when you create a dissolve.

Curve Type box Select hermite or linear as the default curve type for dissolves.

Dissolve Duration field Set the default duration for dissolves.

Blend

Set the default for working with blends.

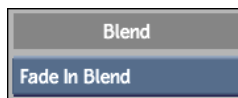

Default Blend Mode box You can set the default Blend mode when you create blending transitions.

Select:	To:
Fade In Blend	Create a mix curve that starts at 100% at the first frame and ends at 0% at the end of the clip.
Constant Blend	Create a constant mix value of 50% for the length of the blend.
Fade In/Out Blend	Fade in to the incoming clip for the first 0.5 seconds and fade out for the last 0.5 seconds. Clips shorter than 1 second fade in for the first 25% of the clip, and fade out for the last 25% of the clip.
Fade Out Blend	Create a mix curve that starts at 0% at the first frame and ends at 100% at the end of the clip.

Soft Resize

Use the Soft Resize area to set the default resize behaviour.



(a) Default Resize Method box (b) Resize Filter box

Default Resize Method box Select the default resize method Flame will use. You can select Letterbox, Centre/Crop, Crop Edges, or Fill.

Resize Filter box If you select a resize method, such as Fill, that requires image re-sampling, the Resize Filter box appears. You can choose from Coarse, Medium, Quality, or Bicubic to determine the quality of the resize. This setting can be overridden when executing a resize operation. This option is not available if the Centre/Crop resize method is selected.

Keep Aspect Ratio If you select Crop Edges or Letterbox as a resize method, the Keep Aspect button appears. Enable Keep Aspect to preserve the pixel aspect ratio of the source clip. This setting can be overridden when executing a resize operation. This option is not available when the Fill or Centre/Crop resize method is selected.

Soft Effects

Set the Preview FX preference when working with clips on the timeline.



Cache Preview FX button Enable to cache frames already rendered on the timeline when frame-stepping through effects.

Batch Mode

Set No Media options to determine how to interpret missing information before (Head), during (Gap), and after (Tail) a clip. See [Modifying Clips in Batch](#) on page 1288.

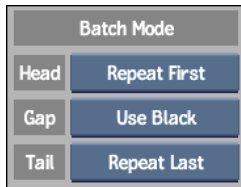

Select:	To:
Repeat First	Substitute each frame of missing media at the beginning of the clip with the first frame of media. Applies to the Head Media menu only.
No Media	Not substitute missing media. Display an error message that there is no media to be processed by the node.
Use Black	Substitute each frame of missing media with a black frame.
Repeat Last	Substitute each frame of missing media at the end of the clip with the last frame of media. Applies to the Tail Media menu only.

Batch FX

Use these preferences when working with Batch FX.

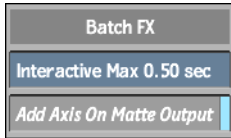

Interactive Max field Enter the number of seconds that you want the system to attempt a render when previewing Batch FX.

Add Axis On Matte Output button Enable to have an Axis soft effect automatically added to the timeline when you output a matte from the BFX output node to the timeline.

Desktop Preferences

Desktop preferences affect how your desktop looks and how you interact with it.

Editing

Use these preferences for desktop editing.

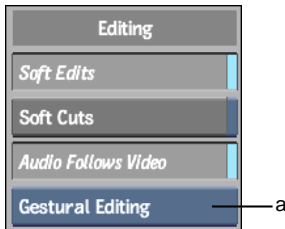

(a) Editing Option box

Soft Edits button Enable the Soft Edits button to enable the soft edit features of Flame. When this button is enabled, heads and tails are retained when editing clips together.

Soft Cuts button Enable the Soft Cuts button to preserve head and tail frames when you cut clips on the desktop.

Audio Follows Video button Use the Audio Follows Video button to specify how audio is edited when you gesturally edit clips. When this button is enabled, gestural edits such as cuts and splices are applied to both video and audio tracks. When it is disabled, gestural edits are applied to video elements

only. Many gestural editing options are affected by the status of this button. See [Cutting Audio Gesturally](#) on page 947.

Editing Option box Use to set the mode for editing clips.

Select:	To:
Drag & Drop	Enable drag and drop operations only (moving, copying, and deleting clips).
Gestural Editing	Enable drag and drop operations and gestural editing operations (cutting, copying, insert edits, replace edits).
Gest. Editing Off	Disable gestural editing and drag and drop operations.

See [Gestural Editing on the Desktop](#) on page 939.

Clips

In this area, set the preferences for clip information.



(a) Resolution/Frame Rate Display box (b) Frame ID box (c) Module Frame ID box

Resolution/Frame Rate Display box Use to show or hide the resolution and frame rate of clips on the desktop reels. The resolution appears in the lower-left corner of each frame. The frame rate appears in the upper-left corner.

Select:	To display:
Resolution and Rate	The clip's frame rate, dimensions, bit depth, aspect ratio, and proxy dimensions.
Size and Rate	The clip's frame rate, dimensions, and proxy dimensions.
Framerate	The clip's frame rate.
Resolution	The clip's dimensions, bit depth, aspect ratio, and proxy dimensions.

Select:	To display:
Size	Clip and proxy dimensions.
No Info	No information about resolution or frame rate.

NOTE 12-bit unpacked clips are displayed as 12u. 12-bit unpacked clips created on an IRIX system display as 12ub on a Linux system. Packed clips have no indicator.

Frame ID box Use to select the frame identification mode for all clips on the desktop reels.

Select:	To display:
Src and Rec TC	The source and record timecode.
KC and Rec TC	The keycode and record timecode.
Keycode	The keycode and frame numbers.
Record Timecode	The record timecode and frame numbers.
Source Timecode	The source timecode and frame numbers.
Frame Numbers	The frame number.
No Frame Display	No information about keycode, timecode and frame numbers.

If the clip has a resolution that does not match the project resolution, the timecode, keycode, or frame numbers that appear on the clip on the desktop and in the clip library are light blue.

The source timecode (on the left) is the timecode on a source clip that you load from a VTR or create in Flame. The record timecode (on the right) is the timecode on the soft edit.

Module Frame ID box Select an option to display the current frame and duration of clips in modules (viewing them in the image window).

Desktop Proxies

Use these preferences to set desktop proxy display options.

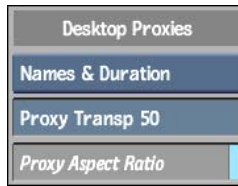

Names/Duration box Use to enable or disable the display of clip names or the durations for all clips. The duration is displayed in frames.

Select:	To:
Names & Duration	Display both the clip name and the duration for each clip.
Duration	Display the clip durations only.
Names	Display the clip names only.
No Name Display	Disable the display of clip names and clip durations.

You can change the name of a clip using the Name command. See [Naming Clips, Reels, and Desktops](#) on page 58.

Proxy Transp field Use to adjust the level of transparency on proxies during drag and drop operations on the desktop and in the clip library. A setting of 0 means the proxy has no transparency when it is dragged. A setting of 100 means the proxy is completely transparent when it is dragged. The default setting is 50.

Proxy Aspect Ratio button Enable to display proxies on the desktop using their format's pixel aspect ratio. Disable this button to display proxies as if all clips used square pixels.

Reels

Use these preferences to set desktop reel display options.

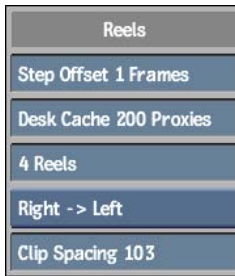

Step Offset field Use to set an offset value, in number of frames, for moving locked reels to the left or right. You move the clips on locked reels by the specified offset by placing the cursor over the clip you want to move and pressing the **left arrow** and **right arrow** hot keys. For more information, see [Locking and Unlocking Reels](#) on page 55.

Desk Cache field Use to set the number of proxies you want to be able to store in RAM. Higher values improve desktop performance by reducing the need to access the proxies on the framestore.

Reels field Use to change the number of reels that are visible on the desktop. You can choose between four and eight reels. The reels automatically scale to fit the desktop as you change the number of reels.

NOTE If you reduce the number of reels that are visible on the desktop when there are clips on all reels, the clips remain on the hidden reels. If you save the desktop, all reels including the hidden ones are saved.

Reel Direction box Use to change the orientation (horizontal or vertical) and direction of the reels on the desktop. The direction of the reels determines which way the frame numbers increment in a clip. The following options are available:

- Right → Left
- Left → Right
- Bottom → Top
- Top → Bottom

NOTE The default orientation and direction is Right → Left.

Clip Spacing field Use to set the amount of space between clips in reels on the desktop.

Audio Preferences

The Audio Preferences menu provides controls for synchronizing audio playback, setting audio I/O, controlling the Lucid ADAT converter (if applicable), and enabling audio waveforms.

Accessing the Audio Preferences Menu

You can access the Audio Preferences from the Desktop (or by pressing **Ctrl+Alt+F6** from anywhere in the application) as part of the overall Preferences menu. You can also access Audio Preferences from the AudioDesk and from the Engineering menu in the Input and Output Clip menus.

To access audio preferences from the Engineering menu:

- 1 From the clip library, click Input Clip or Output Clip.

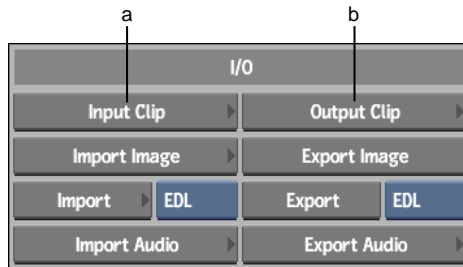

(a) Input Clip button (b) Output Clip button

- 2 In the Input Clip or Output Clip menu, click Eng to display the Engineering menu.

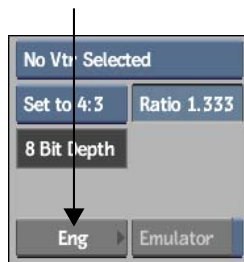

- 3 Click Audio Preferences to display the Audio Preferences menu.

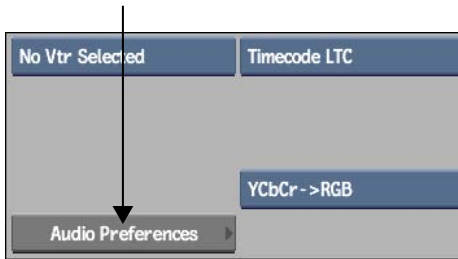

To access the Audio Preferences menu from the AudioDesk:

- 1 Load a clip into the Player.
- 2 From the Player Menu box, select AudioDesk.



- 3 Click Audio Preferences to display the Audio Preferences menu.

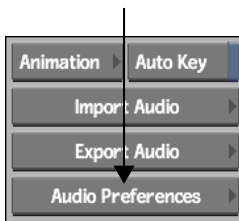

Player

The Player area contains settings to define audio sync during playback.

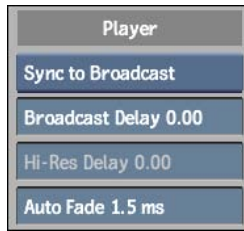

Monitor Sync box Indicates which monitor will have audio sync when you play back a clip—the broadcast monitor or the high-resolution monitor. Use this box to compensate for audio sync differentials between the two monitors. If necessary, specify the audio delay in the corresponding broadcast or high-resolution monitor.

When the Sync to Broadcast option is selected, audio is synchronized to the broadcast monitor during playback. When the Sync to Hi-Res option is selected, audio is synchronized to the high-resolution monitor during playback.

Broadcast Delay field Sets the number of frames (-30.00 to 30.00) to delay the audio signal when syncing to the broadcast monitor. If your hardware setup includes the DVI Ramp 2 and AJA cards, and you are working in 720p, set the delay to -3.5.

Hi-Res Delay field Sets the number of frames (-30.00 to 30.00) to delay the audio signal when syncing to the graphics monitor. If your hardware setup includes the DVI Ramp 2 and AJA cards, and you are working in 720p, set the delay to -3.5.

Auto Fade field Sets the amount of time (0 to 10 ms) that a fade is added to the start and end of each audio segment. Use this setting to avoid audible clicks between audio sources.

The fade is centered on the audio segment boundaries (provided that the segment has enough head and tail frames). If there are not enough head or tail frames in the audio segment, the fade is applied within the segment.

Meters

The Meters area of the Audio Preferences menu provides controls to configure the audio meters in the AudioDesk that you use to monitor inputs and outputs and ensure that audio does not exceed peaks.



Fader meters Use the Fader Meter fields to specify the meter settings for the faders on the AudioDesk. Use the fader meters with the peak meter indicators to ensure clean audio when you output a clip.

Use this field:	To:
Meter Range	Specify the overall scale for the fader meters (12 - 144 db).
Meter Green	Specify the green meter range (-144 - 0 db).
Meter Yellow	Specify the yellow meter range (-144 - 0 dB).
Meter Step	Specify the step value (2 - 9 dB) for the meters. Enter a lower value to view a more detailed meter.

Meter Units box You can change the meters to display either digital or analog units with the Meter Units box.

Select:	To:
Digital PPM (dB)	View the meter in dB.
Analog (VU)	View the meter in VU.

Reset button Resets the meter settings to their default values.

Waveforms

The Waveforms area contains settings you can use to enable waveforms for display in the timeline.

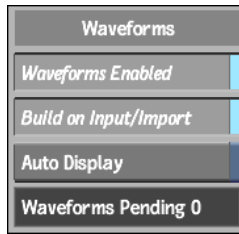

Waveforms Enabled button Enables or disables waveform display.

Build on Import/Input button Enables or disables automatic waveform building on import from file or input from tape.

Auto Display button Enable to display waveforms on all audio timeline segments by default.

Waveforms Pending field If you captured a lot of audio and Build on Import/Input is enabled, waveforms may take time to process. In this case, use this locked field to determine how many clips have not yet had their waveforms built.

Tone

The Tone area allows you to set a default for creating an audio tone clip.



Audio Tone box Sets the default audio tone for Flame. Select SMPTE (US), EBU (Europe), or Custom.

Reference Level field If you select a custom audio tone, set the reference level (from -96 dBFS to 0 dBFS).

General

Use these preferences to set audio head and tail behaviour, and to display supported audio tracks.

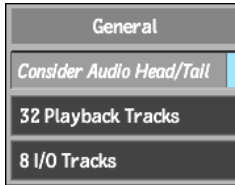

Consider Audio Head/Tail button Enable to include audio that extends before or after video when committing, playing, or exporting movie files. Black video frames are displayed for any sections where audio exceeds video. When disabled, audio is truncated to the same length as the video.

Supported Tracks These locked fields indicate how many audio tracks are supported for input and output operations.

Inputs/Outputs

Depending on how your audio is set up, different input and output settings appear.

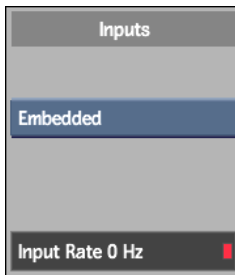

Input Source box Use this box to select AES-BNC, AES-XLR, or Embedded. AES uses the device connected to the AES connection on the video I/O board (BNC or XLR). Embedded extracts the audio tracks from the video signal.

Input Sampling Rate field This locked field displays the current input sampling rate.

Output Source field This locked field displays all current outputs.

Output Sampling Rate field This locked field displays the current output sampling rate.

ADAT Converter

The ADAT Converter area provides settings to configure the ADAT converter for audio I/O and monitoring. The ADAT Converter area and controls only appear if remote control of the ADAT converter is enabled in the software initialisation configuration file.

ADAT Converter	
Input	AES
Rate	48000 Hz
Meters	Analog Out
Analog Inputs	0.0 dB
Analog Outputs	+4 dBu
S.Clip	Lock
	Reset

Lucid ADA 88192 Converter settings

ADAT Converter	
Input	AES
Dig 1-2	AES (XLR)
A/D Sync	AES 1-2
Meters	Digital Out
Analog Inputs	0 dB
Analog Outputs	0 dB

Lucid ADA 8824 Converter settings

NOTE Depending on the model of your ADAT converter, these controls may differ or provide slightly different functionality.

Input box Select either AES or Analog, depending on the Audio I/O device you are using.

Dig 1-2 box Select the type of I/O connection used for I/O channels 1 and 2: AES (XLR) or SPDIF (RCA).

A/D Sync box Select the sync source used by the ADAT converter for analog/digital conversion.

Meters box Select the signal that you want the LED meters on the ADAT to display.

Analog Inputs field Enter an analog input value.

Analog Outputs field Enter an analog output value.

NOTE With the Lucid 88192 ADAT converter, you have the choice of -10 dBV or +4 dBu as analog output values.

S.Clip box Enable to reset the peaking indication on the ADAT display. Peaks occur when the input signal is too hot for the ADAT converter.

Lock box Enable to prevent modifications of the ADAT converter from its front panel.

Reset button Resets ADAT converter parameters to their default values.

Storage Preferences

Storage preferences allow you to test disks, view volume statistics, and calculate available space.

Space Calculation

Use these preferences to view free space and volume statistics.

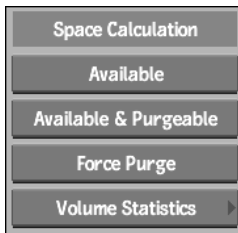

Available box Click to display all available frames in the message bar.

Available & Purgeable box Click to display all available frames, as well as all purgeable frames in the message bar.

Force Purge box Click to purge frames before making the space calculation. Purged frames cannot be recovered.

The amount of available space on your storage device is displayed on the message bar, and is refreshed when an AutoSave occurs. If you turn AutoSave off, then the duration between storage space checks will occur according to the value set for the **DL_CHECKSPACE_DELAY** environment variable.

For example, to set the interval of the space check to 150 seconds, enter the following in the *.cshrc* file: **setenv DL_CHECKSPACE_DELAY 150**

NOTE You can also type the environment variable in a shell before launching Flame to set the value for the current session only.

Volume Statistics button The Volume Statistics utility is a quick way to review the clip libraries on your framestore and identify which ones contain

the most clips. This can be useful when you are housecleaning and need to figure out which clip libraries are likely candidates for freeing up space.

When you click the Volume Statistics button, the Volume Statistics table appears after a few moments. It lists the number of frames, proxies, and audio sources stored in the clip libraries, desktops, and EditDesks of each project. You can also see the total percentage of storage used by each clip library.

Framestore

You can test the disk speed to verify the rate at which the framestore can read data.



Test Disks button When you click the Test Disks button, a message appears in the message bar indicating: the number of frames read per second; the number of seconds required to read a single frame; and the amount of data, in megabytes, read per second.

For example: "TEST DISKS: Sequential Frame Read. 289.09 fps 0.14 spf 289.12 MBps."

The frame used in the calculations is the frame defined by the current project's default resolution.

NOTE Click anywhere to abort the process.

LUT Preferences

Use the LUT preferences to import and list the 3D LUTs you can use in Flame. For more information on using 3D LUTs, see [Viewing Clips with 3D LUTs](#) on page 738.



3D LUT list Displays the list of 3D LUTs that you imported for use in Flame.

TIP You can use a hot key to switch between the first ten 3D LUTs in the list. Press **Shift+Ctrl+1** for the first LUT, **Shift+Ctrl+2** for the second LUT, and **Shift+Ctrl+0** for the tenth LUT in the list.

Import button Opens the Import LUT browser. Navigate to the 3D LUT file you want to use, and select it to load it to the 3D LUT list.

Delete button Deletes the selected LUT from the 3D LUT list.

Delete All button Deletes all LUTs from the 3D LUT list.

Managing Hot Keys

34

Topics in this chapter:

- [About the Hot Key Editor](#) on page 863
- [Determining a Button's Current Hot Key](#) on page 865
- [Hot Key Errors](#) on page 865
- [Accessing the Hot Key Editor](#) on page 865
- [Searching the Hot Key Catalogue](#) on page 868
- [Editing Hot Keys](#) on page 868
- [Creating New Local Hot Keys](#) on page 870
- [Managing Hot Keys](#) on page 870

About the Hot Key Editor

Use the Hot Key Editor to manage hot keys (keyboard shortcuts). The Hot Key Editor allows you to view listings of the current hot keys. You can also modify existing hot keys or create new ones. New and modified hot keys are saved as a user preference.

Map-to-Button and Functional Hot Keys

There are two types of hot keys: *map-to-button* and *functional* hot keys.

Map-to-button hot keys are keystroke sequences that are mapped to a button or a field on the current menu. You can create and edit as many map-to-button hot keys as you like. You can even assign a hot key to options in a pop-up menu.

Functional hot keys are predefined hot keys for specific functions. You cannot create new functional hot keys, but you can redefine and remap the ones provided with the system.

Hot Key Domains

There are three hot key domains: global, shared, and local.

Domain:	Used for:
Local	Hot keys that are available only from a specific module.
Shared	Hot keys that are available from several modules.
Global	Hot keys that are available from anywhere within the system.

Keystroke Conventions

When creating and editing hot keys, the following keystroke conventions apply:

- You are limited to four keystrokes per hot key operation.
- Keystrokes in a hot key operation are pressed at the same time.
- You cannot use a combination of keystrokes more than once.

Logical Ordering

Logical ordering means that the keystrokes in a hot key combination are organized to conform to conventions, regardless of the order in which you enter them. Keys are saved in alphanumeric order except for the following:

- **Alt, Shift, Ctrl** are always saved in that order, regardless of the order in which you enter them.
- **Alt, Shift, Ctrl** are always forced to the beginning of a keystroke sequence.
- **Del, Ins, Home, PgUp, End, PgDn** are always forced to the end of a keystroke sequence.

Since logical ordering is applied to hot key combinations, you cannot use a combination of keystrokes more than once.

Determining a Button's Current Hot Key

You can determine the hot key assigned to a button from anywhere within Flame.

To determine the hot key for a button:

- 1 If auto display of tooltips is enabled in the Preferences menu, hover over the button for which you want to determine the assigned hot key. If you have disabled the auto display of tooltips, press and hold **Alt+Ctrl+spacebar** and hover over the button.

If a hot key exists for the button, it is displayed in the tooltip.

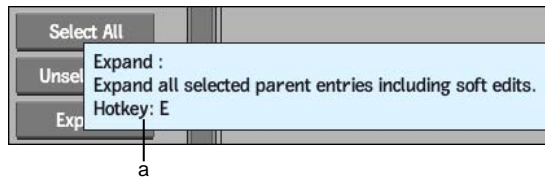

(a) Current hot key message

Hot Key Errors

When you press a hot key, a white keyboard appears in the lower-right corner of the Desktop. If a hot key becomes stuck at any time, the white keyboard remains until you unstick the hot key by pressing it. Click the white keyboard to display the name of the problematic hot key in the message bar.

Accessing the Hot Key Editor

Use the Hot Key Editor to view, modify, and create hot keys.

To access the Hot Key Editor:

- 1 Do one of the following:
 - In the Miscellaneous section of the Preferences menu, click Hotkey Editor.
 - On the Desktop or in any module, press **Alt+Ctrl+F8**.

To exit the Hot Key Editor:

- 1 Do one of the following:
 - If you entered the Hot Key Editor from the Preferences menu, click EXIT.
 - If you entered the Hot Key Editor from the Desktop or any module, press **Alt+Ctrl+F8** again.

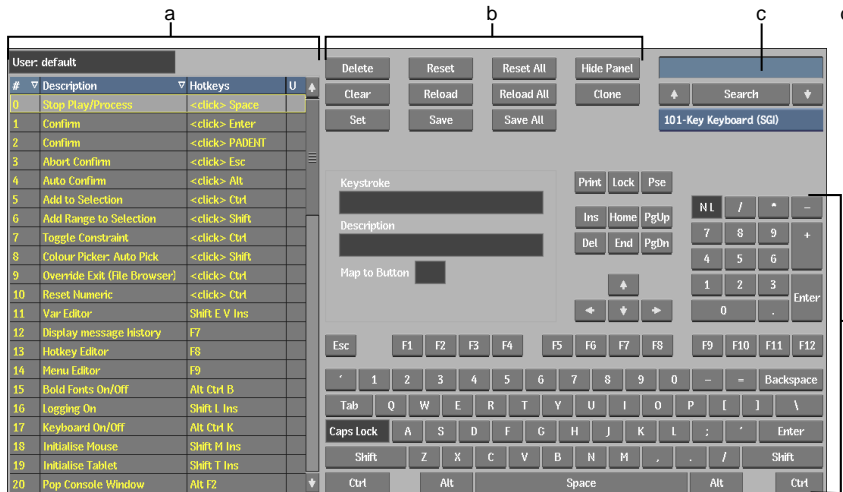

(a) Hot Key Catalogue (b) Hot Key Manager (c) Search Field (d) Keystroke Editor

Hot Key Catalogue

A catalogue of hot keys is maintained for every user. If the user profile was created in the default home directory, the catalogue is found in */usr/discreet/user/effects/<username>/hotkey*. If the user profile was created

elsewhere, the catalogue is found in `<user home directory>/hotkey`. The hot keys in the hot key catalogue are stored in the following formats:

- `default.<component>.butt.hotkey`
- `default.<component>.func.hotkey`
- `factory.<component>.butt.hotkey`
- `factory.<component>.func.hotkey`

Where:	Means:
<code><component></code>	The module containing the hot key.
<code>default</code>	The keystroke that is currently in use.
<code>factory</code>	The Autodesk factory default.
<code>butt</code>	A button hot key.
<code>func</code>	A non-button function hot key.

User-modified hot keys are stored in a separate file:

`default.<component>.butt.hotkey.user`. This file is loaded after the system hot key file, `default.<component>.butt.hotkey`. Entries in the user-modified hot key file replace the system hot key entries, with the exception of cloned hot keys, which are duplicated.

TIP You can use user-modified hot key files to keep your customized hot keys when working on other machines. In a shell, manually copy the `default.<component>.butt.hotkey.user` file to the hot key directory on the new system.

Selecting Your Keyboard Type

In the Hot Key Editor you can select the type of keyboard you are using to take advantage of extra keys on certain keyboards.

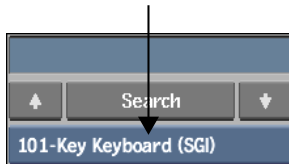

You have the choice of the following keyboards:

- **107-Key Keyboard (Autodesk)** The extra keys available are the Smoke key, the Fire key, the Blank key (beside the Fire key), and the F13, F14, and F15 keys.
- **104-Key Keyboard (PC)** The extra keys available are the left and right Windows key, and the right Menu key.
- **101-Key Keyboard (SGI)** This keyboard has no extra keys available.

When you select your keyboard, the onscreen keyboard is changed to reflect your choice, and entries in the Hot Key Catalogue are updated accordingly.

NOTE If a hot key is set on a key not available for the keyboard selected, the Hot Key Catalogue displays the entry in black.

Searching the Hot Key Catalogue

You can search the Hot Key catalogue to find hot keys whose description match your search criteria.

To search the Hot Key catalogue:

- 1 In the Search field, enter the characters you want to search for.
- 2 Click Search.
The catalogue is searched and the hot keys whose description match your search criteria are highlighted.
- 3 If more than one hot key is highlighted, use the previous and next buttons located next to the Search field to move through the list of search results.

Editing Hot Keys

The Hot Key catalogue shows the global, shared, and local hot keys for the current module.

Editing Local Hot Keys

Almost every module has its own catalogue of hot keys. The hot keys listed in white are local hot keys, and can be customized to suit your needs without affecting other modules. Modified hot keys are saved as a user preference.

To edit a local hot key:

- 1 In the module where you want to use the new hot keys, access the Hot Key Editor (**Alt+Ctrl+F8**).
- 2 Select the hot key in the Hot Key catalogue.
The keystroke sequence and its description appear in the Keystroke Editor fields. If you select a map-to-button hot key, the word “Yes” appears in the Map-to-Button field.
- 3 Click Clear in the Hot Key Manager area to clear the existing keystroke sequence.
- 4 Enter the new keystroke sequence by clicking keys in the Keystroke Editor or by pressing keys on your computer's keyboard.
- 5 Click Set in the Hot Key Manager area.
- 6 Click Save to save the changes to the current user's Hot Key catalogue.
The edited hot key is marked in the catalogue with a “Y” to show that it is user-modified.

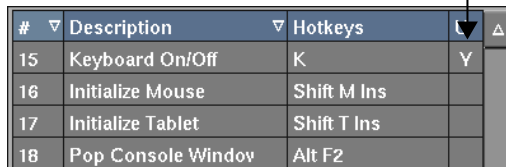

#	Description	Hotkeys		
15	Keyboard On/Off	K	Y	
16	Initialize Mouse	Shift M Ins		
17	Initialize Tablet	Shift T Ins		
18	Pop Console Window	Alt F2		

NOTE If you enter a keystroke sequence that is already in use, an error message is displayed.

Editing Global and Shared Hot Keys

You can edit global and shared hot keys wherever the Hot Key Editor is available. When you access the Hot Key Editor through the Preferences menu,

click Global or Shared to view all current global or shared hot keys, respectively. In this menu, the names of these keys appear in yellow.

In other modules, the global and shared hot keys appear in yellow in the Hot Key catalogue. When changing a global or shared hot key, you are warned that the change will affect all modules, and are asked to confirm the action.

Creating New Local Hot Keys

You can create new map-to-button hot keys only. You cannot create new functional hot keys. New hot keys are saved as a user preference.

To create a map-to-button hot key:

- 1 With the Hot Key Editor open, click the menu button for which you want to create the hot key.

NOTE If the button you want to click is hidden by the Hot Key Editor, click the Hide Panel button.

The name of the menu button appears in the Description field.

- 2 Enter the new keystroke sequence by clicking keys in the Keystroke Editor (or your computer's keyboard).
- 3 Click Set in the Hot Key Manager area.
- 4 Click Save to save the changes to the current user's Hot Key catalogue.

Managing Hot Keys

Use the Hot Key Manager area of the Hot Key Editor to manage the Hot Key catalogues.



Delete Removes a hot key from the current Hot Key catalogue. Select the hot key in the catalogue and click Delete and then click Confirm. You must use Save to make the change permanent.

Clear Clears the contents of the Keystroke field in the Keystroke Editor before you enter a new keystroke sequence.

Set Is the second-to-final step when assigning a keystroke sequence to a button or function. You must use Save as the final step to make the change permanent. See [Editing Hot Keys](#) on page 868 and [Creating New Local Hot Keys](#) on page 870.

Reset Resets the current local hot keys to their default settings.

Reload Reloads the current catalogue of hot keys. This is useful if you made a change but have not yet saved it, and you wish to discard the change.

Save Saves the current hot keys to the current user's Hot Key catalogue.

Reset All Resets all hot keys to their default settings.

Reload All Reloads all hot keys from the current user's Hot Key catalogue.

Save All Saves all hot keys to the current user's Hot Key catalogue.

Hide Panel Hides the Hot Key Editor panel when you want to select a menu button otherwise hidden by the panel. The panel reappears when you select a menu button. Alternatively, click in an open area to return to the Hot Key Editor panel without selecting anything.

NOTE This button is only available when accessing the Hot Key Editor from a module.

Clone Used to assign a regular keyboard keystroke sequence to a single button, field, or function. You can use Clone to map multiple keystroke sequences to a single button, field, or function using the regular system keyboard. This feature does not provide macro functionality.

To clone a button, field, or function:

- 1 Select a button, field, or function in the Hot Key catalogue.
- 2 Click Clone in the Hot Key Manager area to create a second entry for this button, field, or function.
A “Y” appears in the Hot Key catalogue indicating that the cloned hot key is user-modified.
- 3 Activate a control or enter a keystroke sequence on the system keyboard).

NOTE You must enter a keystroke sequence that is not in use. Otherwise, an error message appears.

- 4 Click Set in the Hot Key Manager area of the Hot Key Editor.
- 5 Click Save to save the changes to the current user catalogue.

Topics in this chapter:

- [About Fonts in Flame](#) on page 873
- [Installing Adobe Postscript Type 1 Fonts](#) on page 875
- [Installing Other Supported Fonts](#) on page 876

About Fonts in Flame

A few basic fonts are available the first time you start Flame. Other fonts must be installed. If you are transferring fonts from a Windows or Macintosh machine, there are special considerations, particularly for Adobe Postscript Type 1 fonts.

Supported Fonts

The following font types are supported:

- Adobe Postscript Type 1 fonts: A single-byte font type designed for Roman language fonts; one of the earliest cross-platform (Macintosh and Windows) fonts. These fonts consist of an outline font file and an Adobe font metrics (AFM) file. On Linux systems, the outline file must be a printer font ascii (*.pfa*) file, not a printer font binary (*.pfb*) file as on Windows machines.

- TrueType fonts: A widely used cross-platform font format, easily installed on Linux systems.
- CID (Character ID) fonts: A multi-byte adaptation of Adobe Postscript® Type 1 fonts, well-suited to representing the large character sets of Asian languages such as Japanese, Korean, and Chinese.
- OpenType® fonts: A cross-platform font developed jointly by Adobe and Microsoft®, supporting expanded character sets and layout features such as the euro currency symbol and the broad range of accented characters required by eastern European languages.

Fonts Requiring Additional Work

The following font types require additional work before integration into Flame:

- TrueType Collection (.ttc) fonts: These must be converted to (non-compressed) TrueType font (.ttf) files. Their conversion is beyond the scope of this document.
- FontMonger fonts: These are not Adobe Postscript Type 1 fonts. They can be used in Flame, but must be converted first. See [Installing Adobe Postscript Type 1 Fonts](#) on page 875.

Font Locations

The following directories are used for fonts.

Directory	Purpose
<i>/usr/lib/X11/fonts/Type1</i>	Contains the outline files for Adobe Postscript Type 1 fonts installed with the system or supplied by Autodesk. These files have the extension .pfb.
<i>/usr/lib/X11/fonts/Type1</i>	Contains the Adobe font metrics (AFM) file for Adobe Postscript Type 1 fonts installed with the system or supplied by Autodesk. These files have the extension .afm.
<i>/usr/discreet/font</i>	Contains TrueType (.ttf) files.

Directory	Purpose
Other directories	Can be used to store supported fonts as desired, and are loaded into Flame using the font file browser.

Installing Adobe Postscript Type 1 Fonts

When installing Windows and Macintosh Adobe Postscript Type 1 fonts in Flame, you must first transfer the font files to the Flame system. Then you convert them into a format recognizable by the software. The converter used depends on the source of the font (Windows or Macintosh).

An Adobe Postscript Type 1 font consists of two files. The *.pfb* file contains the outlines for each character. The *.afm* file contains the Adobe font metrics. If the AFM file is not present, you can still use the font in Flame; however, it is preferable to have the AFM file, since it supplies Linux with additional font information, including kerning-pair data.

You can transfer the font files using an NFS or FTP utility. For fonts transferred from a Windows system to a Linux system, you can then use the *pfbtopfa* utility to convert the Windows printer font binary (*.pfb*) file to a Linux-friendly outline font (*.pfa*) file. The AFM file does not require conversion.

For Adobe Postscript Type 1 fonts transferred from a Macintosh to a Linux system, you must install a font-conversion utility, such as *t1utils*.

To use Adobe Postscript Type 1 fonts:

- 1 Use FTP Explorer or a similar file transfer utility to move the fonts from the Windows or Macintosh machine.
- 2 In the transfer utility, set the transfer format to *binary* mode.

NOTE In Mac OS 9 (and earlier) TCP programs, select the *MacBinary* option. In OS X, you will need to install a utility, such as BinJuggler, to encode the files before transferring.

- 3 Transfer the font files to the directory of your choice on the Linux system, keeping the outline file and AFM file together.
- 4 On the Linux system, go to the directory where you transferred the font files.

- 5 For files transferred from a Windows machine, convert the outline file from a printer font binary (*.pfb*) file to a printer font ascii (*.pfa*) file using the *pfbtopyfa* utility:
pfbtopyfa .bin
For example, to convert the Myriad font, type:
pfbtopyfa myriad.bin
- 6 For files transferred from a Macintosh, use a font-conversion utility (such as *t1utils*) to convert the font files.
- 7 After converting the font, clean up the directory by deleting the *.bin* files.
- 8 The next time you start Flame, you can load and select the fonts.

Installing Other Supported Fonts

Most TrueType, CID, and OpenType fonts that you use on a Windows or Macintosh system can be copied to the Linux system for use with Flame.

NOTE TrueType Collection (*.ttc*) fonts are not supported directly. These must be converted to (non-compressed) TrueType font (*.ttf*) files. Their conversion is beyond the scope of this document.

To install other supported fonts:

- 1 Using an FTP or other file transfer utility, copy the fonts from the Windows or Macintosh system to the Linux system.
- 2 In the transfer utility, set the transfer format to *binary* mode.

NOTE In Mac OS 9 (and earlier) TCP programs, select the *MacBinary* option. In OS X, you will need to install a utility, such as BinJuggler, to encode the files before transferring.

- 3 Log in to your Linux system as *root*.
- 4 If necessary, in a terminal, copy the fonts to the directory of your choice.
- 5 The next time you start Flame, you can load and select the fonts.

Topics in this chapter:

- [About Utilities](#) on page 878
- [Volume Integrity Check](#) on page 879
- [Finding and Deleting Invalid Frames](#) on page 880
- [Disk Testing Utility](#) on page 882
- [Log Files](#) on page 882
- [Getting Started with the Command Line Utilities](#) on page 885
- [Command Line Parameters](#) on page 887
- [cmtree](#) on page 890
- [dlfsdump -fs](#) on page 894
- [list_framestore](#) on page 895
- [to_framestore](#) on page 896
- [from_framestore](#) on page 899
- [imcopy](#) on page 901
- [iminfo](#) on page 911
- [fcof](#) on page 912
- [publishTool](#) on page 913
- [stonifiseTool](#) on page 915
- [vstat](#) on page 916
- [vic](#) on page 917

About Utilities

This chapter presents the two types of utilities: a disk testing utility, accessed from the application, and command line utilities, accessed from a shell. In addition, the chapter discusses the volume integrity check and how to find and delete invalid frames.

Disk Testing Utility

Use the disk testing utility, Test Disks, to test your framestore bandwidth.

Command Line Utilities

Use the command line utilities, also known as the DL Tools, from a shell to move clips between files stored on local or remote filesystems and clip libraries stored on your framestore. The command line utilities can be used in the background without affecting the normal operation of Flame.

The following table summarizes the command line utilities.

Utility	Purpose
<i>cmtool</i>	Provides a suite of tools for working with the contents of your volumes. Perform tasks such as adding and deleting clips, libraries, and projects.
<i>dlfsdump -fs</i>	Lists the contents of the specified framestore.
<i>imcopy</i>	Imports, exports, and copies images while performing operations such as cropping, resizing, and format conversion. The Network Filesystem (NFS) must be installed and configured in order to access images on remote systems.
<i>iminfo</i>	Lists clip information.
<i>list_framestore</i>	Lists the contents of the specified project or clip library.
<i>from_framestore</i>	Exports a clip stored in a clip library on the framestore of the local machine to a sequence of SGI image files in a filesystem on a local or remote system.
<i>to_framestore</i>	Imports uncompressed SGI image files from a local or remote filesystem to the framestore of the local machine.

Utility	Purpose
<i>fcof</i>	Finds all clips using the specified frame—find-clip-of-frame (fcof).
<i>publishTool</i>	Publishes clips to the specified directory.
<i>stonifiseTool</i>	Writes clips to the framestore.
<i>vstat</i>	Provides statistics on usage of storage.
<i>vic</i>	(Volume integrity check) Corrects media referencing errors on the framestore.

Volume Integrity Check

When you start Flame, a volume integrity check is performed automatically if a previous crash is detected. This check determines if there are any inconsistencies between the clip metadata stored on the system disk and the frames on the framestore and, when possible, repairs any problems that are found. Inconsistencies can occur if the application crashes before the metadata associated with a clip has been saved to the clip library on the system disk. Metadata for clips on the Desktop is saved by the autosave process, while metadata for clips in the clip library is saved following various operations such as opening a new clip library.

How It Works

The volume integrity check compiles a list of all frame IDs in the clip libraries on the system disk. It then queries the framestore to verify the status of each frame, and compares it to the frame ID data in the list. Each frame on the framestore has one of three statuses—used, unused or free.

Used The frame is used in a clip.

Unused The frame has been deleted in the application (though it still physically exists on the framestore until that area of the framestore is needed for another frame).

Free The storage associated with the frame ID is no longer available (the frame is no longer recoverable).

If the integrity check detects frames that have IDs in the library but have a status of unused on the framestore, it fixes them by changing their status to used.

Also, if the check finds any frames that are used in the framestore but are not listed in the compiled library list, it creates a clip out of them, which it places in the Lost+Found clip library. The order of these frames will be the order in which they were created.

NOTE If the integrity check discovers empty soft partitions, they are automatically removed.

Lastly, if the check finds frame IDs in the library list for which there are no corresponding frames on the framestore, it reports them as invalid frames in an error message displayed at the end of the check. Invalid frames occur if Stone and Wire was prevented from writing new frames to the framestore during a work session, for example, because of a system failure or power failure. By default, Stone and Wire updates itself every 300 seconds or after 2000 changes occur, whichever comes first. A change includes the creation of a new frame or any change made to an existing frame. Therefore the maximum amount of work that could be lost from this situation is 300 seconds, or 5 minutes of work.

Forcing a Volume Integrity Check

You can force a volume integrity check using an environment variable in the shell where you launch Flame or you can use the *vic* utility. See [vic](#) on page 917.

To force a volume integrity check on start-up:

- 1 In the shell where you plan to launch Flame, turn on the volume integrity check by typing:

```
setenv DL_FORCE_IC
```
- 2 Start Flame. See [Starting Flame](#) on page 919.
A volume integrity check is run before Flame starts.

Finding and Deleting Invalid Frames

When invalid frames exist on the Desktop or in a clip library, they appear as black or red frames. These frames are not recoverable. If you get a message stating that invalid frames exist, you should delete them because their presence slows system performance. You have the option of deleting the entire clip to which they belong or deleting just the invalid frames in the clip.

The *vic* utility identifies invalid frames and lists their IDs in the system console and SYSLOG. They can then be used as arguments to the *fcof* utility (find-clip-of-frame) to find which clip or clips use them.

You can also use the *vic* utility in repair mode (with the **-r** flag) to do this automatically. This option enables *vic* to search the media library and replace missing frame ids with a LOST frame label. In the library, the names of impacted clips appear red. When these clips are loaded into the record timeline, the names of the affected segments also appear red. Lost frames are displayed with the LOST label over them. The flag set on clips is not permanent, so resaving the clip will remove the red from the names.

The following procedure explains how to locate and delete invalid frames in clips located on the Desktop and in clip libraries.

To find and delete invalid frames:

- 1 Exit the application.
- 2 In the command shell where Flame was launched, make sure */usr/discreet/io/<version number>/bin* is in your path.
- 3 Start the utility by typing:

```
fcof <framestore volume> <frameId> [-v]
```

Option	Function
framestore volume	Specifies the volume to check (stonefs, stonefs1, stonefs2).
frameID	Specifies the frame's ID (0x1234abcd5678cdef).
-v	Enables additional verbosity.

fcof scans all the libraries on the specified volume searching for clips referencing the given frame. The output tells you which clips use the frame and where they are located. When a large list of invalid frames is detected, it is usually more efficient to find the clip for a given frame, delete it, and perform another integrity check before searching for the next invalid frames. Very often all invalid frames are in the same few clips so finding affected clips for each invalid frame is unnecessary.

Disk Testing Utility

A disk testing utility, Test Disks, is accessible from the User Interface. Use it to assess the framestore's performance.

To verify framestore performance:

- 1 In the Preferences menu, click the Storage button.
- 2 Under Framestore, click Test Disks.



The raw performance of the framestore appears in the message bar. The display includes:

- The number of frames read per second
- The number of seconds it takes to read one frame
- The average amount of data read in a second, in MB per second

For example:

TEST DISKS: Sequential Frame Read.289.33 fps 0.14 spf. 289.16 MBps.

Click anywhere to abort the process.

Log Files

You can access log files for Flame. Log files are useful for tracking the success or failure of operations. For example, you can use a log file to find a problem that occurred on a particular date with Flame.

Viewing Log File Messages

Use the following procedure to view the contents of a log file for Flame.

To view the contents of a log file:

- 1 Change to the log directory for the application by typing:
`cd /usr/discreet/log/`

- 2 When you are diagnosing when and why an error occurred, it can be useful to view the names of all the log files corresponding to a given application with the date that each log file was created.

View the log files corresponding to the application by typing:

```
ls -ltr /usr/discreet/log/<application>*
```

Where <application> is an application such as Flame.

The following is an example of feedback for Flame.

```
-rw-rw-r--1 root user  5785   Apr 5   09:52  flame2009_detroit_app.log.4
-rw-rw-r--1 root user 146977  Apr 5   14:54  flame2009_detroit_app.log.3
-rw-rw-r--1 root user  13765  Apr 7   10:15  flame2009_detroit_app.log.2
-rw-rw-r--1 root user   2732  Apr 8   14:59  flame2009_detroit_app.log.1
-rw-rw-r--1 root user   2732  Apr 8   15:54  flame2009_detroit_app.log
```

Where the `_app` suffix indicates the log file is an application log file. See [Types of Log Files](#) on page 884. The <number> suffix distinguishes log files for the same application.

- 3 View the contents of the application log file by typing:

```
keddit <application>.log.<log file number>
```

Where <application> and <log file number> vary depending on the file you want to view.

The following is an example of feedback from the `Flame2009.log.1` file.

```
# Discreet flame2009_detroit_app log file - 1.0
# Started - (EST) Mon Apr 19 13:56:52 2009
# Hostname - detroit
[notice] 2246 CoMsgLogger.C:86 06/19/09:13:56:51.978 Command line:
'flame2009_detroit_app'
[notice] 2246 log.C:235 06/19/09:13:56:52.070 Autodesk(r) Flame(r)
[notice] 2246 log.C:236 06/19/09:13:56:52.070 Version 2009
[notice] 2246 log.C:237 06/19/09:13:56:52.070 (c) Autodesk Canada Inc./Autodesk
Inc., 1997-2009. All rights reserved.
[notice] 2248 CoThreadLinux.C:145 06/19/09:13:56:52.077 Registered process 'logger'
[notice] 2249 CoThreadLinux.C:145 06/19/09:13:56:52.084 Registered process 'Remote
Command Server'
[notice] 2246 swClient.C:147 06/19/09:13:56:52.095 Using Stone+Wire API 2009.0.
```

[notice] 2246 swxStoneAdapter.C:798 06/19/09:13:56:52.220 Compatible S+W filesystem driver (1119) and S+W API (1126) versions detected.
[notice] 2246 swxStoneAdapter.C:855 06/19/09:13:56:52.222 Compatible SWR driver (1119) and S+W API (1126) versions detected.
[notice] 2246 SWCentralPath.C:40 06/19/09:13:56:52.222 Central path not specified.Using default: '/usr/discreet'.
[notice] 2246 swxStandardFSAdapter.C:428 06/19/09:13:56:53.532 Using StandardFS Path /usr/discreet/clip/standardfs.links.

Where [notice] indicates the type of log file entry. See [Interpreting Application and VIC Log File Messages](#) on page 884.

Types of Log Files

There are four types of log files that are generated for Flame.

Application Contains all types of messages associated with the current application. The application log file name has the following format:

<application name>_<build type>_<host>_app.log[.<index>]. For example, Flame2009_n32_detroit_app.log.1

Shell Contains all messages that appear in the start-up shell where you launched the application. The shell log file name has the following format:

<application name>_<host name>_<date application was launched (year:month:day)>_<time application was launched (00:00:00-hour:minute:second-24 hour clock)>_shell.log. For example, Flame2009_detroit_20090329_170238.log.1

Volume Integrity Check (VIC) Contains the volume integrity check messages. See [Volume Integrity Check](#) on page 879. The log file name is vic.log.<number>.

Flame error Contains all the error messages generated by Flame. The log file name is *ifffs.error.log*.

Interpreting Application and VIC Log File Messages

A log file is composed of separate entries. If the log file is an application or VIC log file, it contains a message level, time stamp, and a message. The

following example, taken from an application log file, is used to illustrate the contents of a log file entry.

```
[notice] 2246 swClient.C:147 04/19/09:13:56:52.095 Using Stone+Wire API 2009.0.
```

Message level Indicates the severity of the message, as described in the following table. In this example, [notice] is the message level.

Type of Message	Relays Information About	Example
User	An operation that was successful.	Setup loaded successfully
Error	An operation that was unsuccessful.	Cannot delete file '/tmp/image.jpg': Permission denied
Warning	An operation that was successful but had accompanying errors.	When you are loading a setup, you receive the following message: Cannot find clip: 'PAL BARS.'
Notice	An operation that was successful but completed slightly differently than expected.	Stone+Wire client connection successful on port 7002.

Time stamp Indicates the time the application was launched. Time, including the date, is tracked by the hardware timer to the nearest one thousandth of a second. In this example, the time value is 06/19/04:13:56:52.095.

Message Indicates the success or failure of operations performed by an application. In this example, the message is Using Stone+Wire API 3.0.

Getting Started with the Command Line Utilities

The command line utilities, DL Tools, can be found in *usr/discreet/io/<version number>/bin*. This path is added to your *.cshrc* file when you install Flame. You do not need to type the path name to execute the utilities.

NOTE *<version number>* is the version of DL Tool and not the software version number.

The command line utilities can be used in the background without affecting the normal operation of Flame.

Determining the Utilities Version

Since the command line utilities are stored in *usr/discreet/io/<version number>/bin*, it is useful to know what version has been installed.

To determine the utilities version:

- 1 Open a command shell.
- 2 Type:

```
versions -bn | grep -i dltools
```

This produces output in the following format:

```
I DLtools<version_nbr> <package_nbr> discreet tools,  
version <version_nbr>
```

In this output, the last four digits of the package number represent the build. This number can be useful when reporting to technicians during troubleshooting.

Example

The following represents a typical output of the **versions** and **grep** commands when used in the previous procedure:

```
I DLtools83 1658372105 discreet tools, version 8.3
```

In this case, the *<package_nbr>* is 1658372105, the build number is 2105, and the *<version_nbr>* is 8.3.

Gaining Access to the Remote Machine

The *.rhosts* file defines which remote hosts can invoke commands on the local machine without requiring a password. To use the *to_framestore* and *from_framestore* utilities successfully, you must add an entry to the remote machine's *.rhosts* file. Otherwise, you will be denied access to it.

To modify the *.rhosts* file:

- 1 On the remote machine, log in to the account from which you will be running Flame.
- 2 Open a command shell.
- 3 Change to the account's home directory by typing:
`cd ~`
- 4 Open the *.rhosts* file (or create one) using a text editor.
If it does not exist, create a new one.
- 5 Add the following line (if it is not already present):
`+ <host name>`
where *<host name>* is the name of the machine where you will be running the utilities.
- 6 Save the file and close the text editor.
- 7 For safety, ensure you are the only user that can write to the file:
`chmod 644 .rhosts`

Command Line Parameters

The following sections describe the parameters required in the *list_framestore*, *from_framestore*, *to_framestore*, and *imcopy*, utilities.

Clip Directory Pathname

To use the *list_framestore*, *from_framestore*, *to_framestore*, and *imcopy*, utilities, you need to provide a path to a framestore clip as the source or destination of the operation. The format of this path is the following:

```
/usr/discreet/clip/<volume>/<project>/<library>@<clip  
name>
```

where

- *<volume>* is the name of the volume you are using. The first volume on a system is *stonefs*. If you have multiple volumes on the system, you need to specify *stonefs1*, *stonefs2* to access additional *stonefs* volumes.

- `<project>` is the name of the project containing the library you want to access. The command: `ls -l /usr/discreet/clip/stonefs | grep "^d"` lists the projects currently in use on volume stonefs.
- `<library>` is the name of the library in that project. The command: `ls -l /usr/discreet/clip/stonefs/myproject/*.000.clip` lists all the libraries currently defined in *myproject*. Only the leading part of the library filename should be used as the `<library>` part of the path to the clip; you should not add the `.000.clip` to it. For instance, assuming you have a library file *BigLib.000.clip* in project NTSC on framestore stonefs, the clip path format would be:
`/usr/discreet/clip/stonefs/NTSC/BigLib@myclip`
- `<clip name>` specifies the name and location of the clip. See [Clip Name Format](#) on page 888.

Clip Name Format

The following clip naming formats are used to specify the location of clips in the *list_framestore*, *to_framestore*, *from_framestore*, and *imcopy*, utilities.

Absolute Paths

An initial `/` indicates that the path for the clip is anchored at the root of the library. The following three formats can be used to find or list clips:

`/Desktop1/Reel1/Clip1`

where Clip1 is on the reel named Reel1 on Desktop1.

`/Reel12/Clip2`

where Clip2 is on the reel named Reel2.

`/Clip3`

where Clip3 is located at the root of the library.

Relative Paths

If you do not know the absolute path, you can omit the initial `/` and Flame will search the library for the reel and/or clip. The following two formats can be used to find clips if you do not know the absolute path:

`Reel13/Clip3`

where Clip3 is on Reel13, which is located inside the library.

Clip4

where Clip4 is located inside the library.

Untitled Desktops, Reels, and Clips

Flame uses one or more / to refer to an unnamed clip, desktop, or reel.

/

is an unnamed clip in the library.

//

is an unnamed clip in an unnamed reel in the library.

///

is an unnamed clip in an unnamed reel in an unnamed desktop.

//Reel15/Clip5

Clip5 is on Reel5 in an unnamed desktop.

/Desktop6//Clip6

Clip6 is on an unnamed reel on Desktop6.

/Desktop7/Reel7/

is an unnamed clip on Reel7 which is located on Desktop7.

Duplicate Clip Names

If more than one clip has the same name, you can also specify the date and time of the particular clip to be chosen.

File Template

In the *from_framestore*, and *imcopy* utilities, you can use a file template to specify a pattern from which the name of each destination image file will be derived. Similarly, in the *to_framestore* utility, you can use a template to specify a sequence of source image files. In the *imcopy* utility, both the source and destination can be image sequences specified by a file template.

The *from_framestore* utility (as well as *imcopy* when used to export from a framestore clip) stores each frame of a clip as a separate image file in a local or remote filesystem.

Image files are numbered sequentially so that the order of frames in the clip can be maintained in transfers. Specify the filename and the numbering format for the image files with the following file template:

```
<clip name>%04d.sgi
```

The 4 instructs the utility to use four digits when numbering the files; the 0 instructs it to use leading zeros before the file number.

For example, if you use the file template *example%04d.sgi* in the *from_framestore* utility, the following image files are stored in the specified destination directory:

- *example0001.sgi*
- *example0002.sgi*
- *example0003.sgi*, etc.

The *to_framestore* utility looks for matching filenames in the specified source directory.

cmtool

The *cmtool* utility includes options that you can use to work with the contents of your volumes. Without entering the application, you can perform activities such as opening, closing, deleting, and renaming volumes, projects, partitions, archives, and libraries. Additionally, you can view the contents of volumes, projects, partitions, archives and libraries.

NOTE You can use *cmtool* to determine the unique ID (UID) of a clip. Both *publishTool* and *stonifiseTool* accept a UID instead of the name and creation date of a source clip. To determine the UID of a clip, list the contents of the library in which it resides, locate the clip, and find its UID in the clip ID column. A UID has the format H_0000000000_S_0000000000_U_000000.

To start *cmtool*:

- 1 Make sure that */usr/discreet/io/<version number>/bin* is in your path.
- 2 Type:
cmtool
The *>cmtool* prompt appears.

- 3 At the `>cmttool` prompt, type a *cmttool* option. See [cmttool Options](#) on page 891.

Example

```
open volume stonefs
```

To view the available *cmttool* options:

- 1 Make sure that `/usr/discreet/io/<version number>/bin` is in your path.
- 2 Type:
`cmttool`
- 3 Type:
`help`

cmttool Options

The following options may be used with *cmttool*.

Option	Function
<code>ls volume</code>	Lists the framestore, host name, amount of used and available frames, all partitions, and all projects for the current volume.
<code>ls project</code>	Lists the project management settings for the current project such as the resolution, aspect ratio, and scan mode. Additionally, all libraries are listed.
<code>ls library</code>	Lists the contents of the current library. You must open the volume, project, and library before you use this command.
<code>ls partition</code>	Lists the partition settings such as the address, size, percentage of the volume occupied, frame size, proxy depth, and aspect ratio.

Option	Function
ls archive	Lists device type, header name, segment file name, and all entries in the archive.
ls entry <entry index number>	Lists the entry name, its class and the date of creation.
delete <library name>	Deletes the library.
delete <project name>	Deletes the project.
delete <partition name>	Deletes the partition.
delete <entry index number>	Deletes the entry.
close volume <volume name>	Closes the volume.
close project <project name>	Closes the project.
close partition <partition name>	Closes the partition.
close archive <archive name>	Closes the archive.
close library <library name>	Closes the library.
close all	Closes all volumes.
open volume <volume name>	Opens the volume.
open project <project name>	Opens the project and sets it as the current project.
open partition <partition name>	Opens the partition and sets it as the current partition.
open library <library name>	Opens the library and sets it as the current library.

Option	Function
open archive -file <file name>	Opens the file archive.
open archive -tape <tape device name>	Opens the tape archive.
set volume <volume name>	Sets the volume as current.
set project <project name>	Sets the project as current.
set partition <partition name>	Sets the partition as current.
format archive -file <file name> <archive name> <capacity>	Formats the file archive. If a file archive exists with the same name, the contents are erased.
format archive -tape <tape device name> <archive name> <capacity> <block size>	Formats the tape archive. If a tape archive exists with the same name, the contents are erased.
format partition <partition name>	Formats the partition archive. If a partition exists with the same name, the contents are erased.
format project <project name>	Formats the project. If a project exists with the same name, the contents are erased.
rename partition <new partition name>	Renames the current partition.
generate <clip name> <number of frames> <frame width> <frame height>	Creates a clip within the current library.
generateTone <clip name> <number of frames> <number of tracks>	Creates an audio clip containing a tone within the current library.
importAudio <clip name> <file, file2,...>	Creates a clip and appends all the tracks specified by the list of audio files.

Option	Function
add library <library name>	Creates a library within the current project.
lock volume	Locks the current volume to prevent users on other hosts from accessing the volume.
get framestorename <host name>	Lists the name of the framestores.
show framestores	Lists the names of all framestores on the network.
quit	Exits the <i>cmttool</i> utility.

dlfsdump -fs

Use the *dlfsdump -fs* utility to obtain a list of the contents of a framestore. Some of the lists you can view include libraries, projects, tracks, and source clips.

Syntax

```
dlfsdump -fs <framestore name> <dlfsdump -fs option>
```

Where:

Is:

<framestore name>

The name of the framestore, for example, *stonefs*.

Example

```
dlfsdump -fs stonefs -projects
```

dlfsdump -fs Options

The following options may be used with *dlfsdump -fs*.

Option	Function
-projects	Lists all projects for the volume.

Option	Function
-libraries	Lists all libraries on the volume.
-path <path of project> -libraries	Lists all libraries in the project.
-libraries -desktoponly	Lists all Desktops in the project.
-path <path of project or library> -clips	Lists all clips in the project or library.
-tracks	Lists all tracks on the volume.
-sources	Lists all source clips on the volume.
-media	Lists all media on the volume.
-frameids	Lists all frame IDs for the frames on the volume.
-path <path of the pro- ject or library> -frameids	Lists all frames in the project or library.
-allids	Lists all IDs for libraries, Desktops, reels, and clips.
-id <clip ID> -frameids	Lists the frame IDs of the clip with the given clip ID.

list_framestore

The *list_framestore* utility lists the contents of each clip library that you create in a framestore project. You can use the *list_framestore* utility to list the contents of the framestore before using the *to_framestore*, *from_framestore*, or *imcopy*, utilities.

The listing shows the absolute path to the clip, the clip name, its creation date and time, and its description. For a source clip, the description is the timecode and the number of frames.

Syntax

```
list_framestore <clip directory pathname>
```

Where:

Is:

<clip directory
pathname>

The clip directory pathname of the clip library. For example: */usr/discreet/clip/stonefs/NTSC/paint*.

Example

The following command lists the contents of the framestore for a project called WARSHAW. It contains two libraries, the default, and *WARSHAW_ON_THE_MAIN*. Both libraries contain two clips:

```
list_framestore  
/usr/discreet/clip/stonefs/NTSC_50_FS0/NAB08_LYCOS  
  
LIBRARY  
/usr/discreet/clip/stonefs/NTSC_50_FS0/NAB08_LYCOS  
/LYCOS/LYCOS_MASTER/LYCOS/LYCOS_NATIONAL_FINAL  
/LYCOS-24P/3:2--0001/LYCOS-24P/FM-0001/LYCOS-24P/3:2--0003  
/LYCOS-24P/3:2--0004/LYCOS-24P/0005/LYCOS-24P/3:2--0006/LYCOS-24P/
```

Note the order of information in the output: the reel name, clip name, creation date, creation time, start timecode and length in frames. An “A” at the end of a line indicates an audio clip.

to_framestore

The *to_framestore* utility copies image files from the specified directory to the framestore.

Once the transfer is complete, the clip is available in the clip library. You can use the Load Clip command to load the clip to the Desktop reels. See [Loading Clips to the Desktop](#) on page 591.

Syntax

```
to_framestore [-v|w] [-f  
startframe]"<clip library pathname>@<clip name>" <hostname>:<directory
```

pathname>/<file template> [<starting frame number>[<ending frame number>]]

Where:	Is:
<clip library path-name>	The directory pathname of the clip library. This pathname is displayed in the LIBRARY line of the <i>list_framestore</i> listing. For example: <i>/usr/discreet/clip/stonefs/NTSC/paint</i> .
<clip name>	The name of the clip as shown in the first column of the <i>list_framestore</i> output.
<hostname>	The hostname of the local or remote machine where the destination filesystem resides.
<directory path-name>	The path of the destination directory on the local or remote machine.
<file template>	The template used to name and number the image files, for example, <i>example%04d.sgi</i> .
<starting frame number>	The number of the first frame in the clip that you want to copy (optional).
<ending frame number>	The number of the last frame in the clip that you want to copy (optional).

NOTE If the message `remuser too long` appears when you initiate *to_framestore*, the current user name exceeds eight characters. In this case, use the **su** (substitute user identity) command to switch to another user's identity with a user name of eight characters or less. Note that you must enter the corresponding user password.

to_framestore Options

The following options may be used with *to_framestore*.

Option	Function
-v	A flag that causes the utility to operate in verbose mode.
-l	A flag that overrides the default, when reading or writing 12-bit images, and causes the utility to use the 12 least significant bits. 12-bit images

Option	Function
	are stored in 16 bits. By default, image data is stored in the 12 most significant bits. This flag is used mainly when working with 16-bit SGI image files originating from an Oxberry film scanner.
-w	A flag that causes the utility to wait one second between reading each frame from the directory. This option applies to the <i>to_framestore</i> utility only.

Using 12-Bit Clips

You can use *to_framestore* with 12-bit clips. When importing 16-bit SGI image files, *to_framestore* expects to find the 12 bits of data in the 12 most significant bits of each colour component. You can use the `-l` command line option to tell it to look at the 12 least significant bits instead. These options are most commonly used when working with 16-bit SGI image files originating from an Oxberry film scanner. See [About Importing Media Files](#) on page 193.

Restrictions

The following restrictions apply to the *to_framestore* utility:

- Only RGB non-RLE encoded SGI images can be used. If you have SGI images that use RLE encoding, you can use the */usr/sbin/verbatim* utility to convert these to non-RLE encoding.
- The image files to be imported with *to_framestore* must be the same size as the default resolution for the project into which you will import the images.
- The *to_framestore* utility must be invoked from the machine on which the framestore resides.
- If you specify the name of an existing clip as the destination clip name, *to_framestore* will create a new clip with the same name. You cannot overwrite or replace an existing framestore clip. See [File Template](#) on page 889.

from_framestore

The *from_framestore* utility copies clip information files from the framestore on the local machine and saves them as image files in the specified destination directory.

If you transfer two or more clips with the same name, the most recent clip is used unless you specify otherwise.

Before using the *from_framestore* utility, make sure the clip has been saved in the clip library. See [Saving to Clip Libraries](#) on page 561.

Syntax

```
from_framestore [-v1]
"<clip library pathname>@<clip name>" <hostname>:<directory
pathname>/<file template> [<starting frame
number>[<ending frame number>]]
```

Where:	Is:
<clip library path- name>	The directory pathname of the clip library. This pathname is displayed in the LIBRARY line of the <i>list_framestore</i> listing. For example: <i>/usr/discreet/clip/stonefs/NTSC/paint</i> .
<clip name>	The name of the clip as shown in the first column of the <i>list_framestore</i> output.
<hostname>	The hostname of the local or remote machine where the destination filesystem resides.
<directory path- name>	The path of the destination directory on the local or remote machine.
<file template>	The template used to name and number the image files, for example, <i>example%04d.sgi</i> .
<starting frame number>	The number of the first frame in the clip that you want to copy (optional).
<ending frame num- ber>	The number of the last frame in the clip that you want to copy (optional).

NOTE If the message `remuser too long` appears when you initiate *from_framestore*, the current user name exceeds eight characters. In this case, use the **su** (substitute user identity) command to switch to another user's identity with a user name of eight characters or less. Note that you must enter the corresponding user password.

Example

```
from_framestore
/usr/discreet/clip/stonefs/NTSC/paint@jaune
sgi2:/usr/tmp/jaune%04d.sgi
```

This command retrieves the clip information for all frames in the clip *jaune* from the clip library */usr/discreet/clip/stonefs/NTSC/paint*, and creates the image files *jaune0001.sgi*, *jaune0002.sgi*, and so on in the directory */usr/tmp* on the remote machine *sgi2*.

from_framestore Options

The following options may be used with *from_framestore*.

Option	Function
-v	A flag that causes the utility to operate in verbose mode.
-l	A flag that overrides the default, when reading or writing 12-bit images, and causes the utility to use the 12 least significant bits. 12-bit images are stored in 16 bits. By default, image data is stored in the 12 most significant bits. This flag is used mainly when working with 16-bit SGI image files originating from an Oxberry film scanner.
-w	A flag that causes the utility to wait one second between reading each frame from the directory. This option applies to the <i>to_framestore</i> utility only.

Using 12-Bit Clips

You can use the *from_framestore* utility with 12-bit clips. By default, when exporting a 12-bit clip, *from_framestore* creates 16-bit SGI image files with the 12 bits of data from the framestore in the 12 most significant bits of each 16-bit colour component. You can override this behaviour with the `-l`

command line option, which forces the data to be stored in the 12 least significant bits of each 16-bit colour component.

Restrictions

The following restrictions apply to the *from_framestore* utility:

- Only RGB non-RLE encoded SGI images can be used. If you have SGI images that use RLE encoding, you can use the */usr/sbin/verbatim* utility to convert these to non-RLE encoding.
- The *from_framestore* utility must be invoked from the machine on which the framestore resides.

imcopy

imcopy is a powerful utility that lets you import and export images or image sequences from the framestore and convert them to any image format supported by Flame. It supports image operations such as cropping, scaling, and LUT conversion. In addition, *imcopy* allows you to select the output compression.

While *from_framestore* and *to_framestore* work with uncompressed SGI image files only, *imcopy* recognizes all the image file formats supported by Flame. However, unlike *from_framestore* and *to_framestore*, this utility must have direct access to the image files, whether on a local filesystem or on a remote host accessed via NFS.

Use *imcopy* to:

- Convert image formats supported by Flame. *imcopy* supports 8 bits per component or greater for image formats such as Cineon, SGI, Wavefront™, TIFF, Tdi/Maya, and DPX.
- Apply a LUT (Lookup Table) for linear-to-log conversion.
- Crop and resize images upon import/conversion.
- Extract the alpha channel from an RGBA image, and output it as a separate file.

To start imcopy:

- 1 Make sure that */usr/discreet/io/<version number>/bin* is in your path.

2 Type:

imcopy <imcopy options> <in file name and path> <out file name and path> <start index> <stop index>

Syntax

imcopy [-f] <format> [-c] <channel format> [-m] <output image compression> [-o] <origin of source> [-s] <source width and height> [-d] <width and height of destination image> [-t] <destination aspect ratio> [-l] <full path of input lut file> [-w] <full path of output lut> [-v] [-b] <r,g,b values of background> [-i] <bits per pixel in internal buffer> [-e] <bits per pixel of output image> [-u] [-k] <crop setting> [-q] <resize quality> [-D] <scan mode> [-F] <framecode mode of clip> [-j] <jpeg compression factor> [-a] [-A] <audio file name> [-x] [-M] [-n] <physical device> [-p] <image pan x,y values> [-P] [-T] <timecode> [-O] [-g] <proxy generation setting> <in file name and path> <out file name and path> <start index> <stop index> <step factor>

Where:	Is:
<in file name and path>	The name of the file that you are inputting.
<out file name and path>	The name of the file that you are outputting.
<start index>	The start frame of the file.
<stop index>	The end frame of the file.
<step factor>	The frames of the file that you are outputting.

Example

```
imcopy -k fitall -d 2048,1556 -q quality -f Cineon  
/usr/discreet/clip/stonefs/NTSC/video@clip_name  
/usr/tmp/clip_name.%04d.cineon
```

NOTE %04d means use 4 digits padded with zeroes; %d means do not use any padding for the numeric part of the name.

To view the available `imcopy` options:

- 1 Make sure that `/usr/discreet/io/<version number>/bin` is in your path.
- 2 Type:
`imcopy`

imcopy Options

The following options may be used with `imcopy`.

Option	Function	Default
-f	Sets output file format.	Same as source image
-c	Sets output channel format (BW, RGB, or RGBA).	Same as source image
-m	Sets output image compression (default, none, rle, lzw).	Same as source image
-o	Sets (x,y) source origin in <i>infile</i> .	0,0
-s	Sets source width and height in <i>infile</i> .	Whole file
-d	Sets destination image width and height.	Same as source image
-t	Sets the destination aspect ratio. Accepts floating point values; i.e. 4:3 as 1.33, 16:9 as 1.77, etc.	Same as source image
-l	Maps input pixels through LUTs in the <i>inlut</i> file. Specify the full path to the LUT file.	No mapping
-w	Maps output pixels through LUTs in the <i>outlut</i> file. Specify the full path to the LUT.	No mapping
-v	Specifies verbose reporting.	Non-verbose
-i	Sets bits per pixel (bit depth) in the internal buffer (8 or 12).	8

Option	Function	Default
-e	Sets bits per pixel in the output image (8, 10, 12 16).	8
-u	Stores 12-bit images in unpacked mode. By default, 12-bit images are stored using 12 bits of data. In unpacked mode, they are stored in 16 bits of data, the OpenGL® standard.	Packed
-b	Sets R,G,B, or a background colour between 0.0 and 1.0.	0.0, 0.0, 0.0, 0.0
-k	Sets cropping type (crop, fit, fitall, or fitboth): - <i>crop</i> centres and crops the image. - <i>fit</i> scales the longest edge to fit the frame size. - <i>fitall</i> scales the shortest edge to fit the frame size and crops the longest edge. - <i>fitboth</i> scales both X and Y to fit the new frame size and distorts the image. Use the -b option to specify the colour of the cropped part of the image (default is black).	crop
-q	Sets resize quality: coarse, medium, quality, bicubic.	quality
-D	Sets the scan mode for the media: F1, F2, or P.	None
-F	Sets clip frame code mode: 24, 25, 30, 30DF, 50, 60, 60DF.	30
-j	Sets JPEG compression factor (0-100).	75
-a	Combines alpha file: -a <file to go in alpha channel>.	None
-A	Specifies the audio files to add to the media. You can add more than one audio file by separating the audio file names with commas.	None
-x	"invert" or "noinvert", extracts alpha channel to <file-name>_alpha.	None
-M	Creates a matte container. You must use -x in conjunction with this command to create a matte.	None
-n	Sets which physical device the media was captured from. For example, you can specify a tape name.	Imported

Option	Function	Default
-P	Pans image by x and y.	0, 0
-P	Soft imports the media.	None
-T	Sets the start timecode of the media.	00:00:00:00
-O	Specifies an offset in the sequence of exported images.	Same as start index
-g	Generates proxies (first, all, or none): - <i>first</i> generates proxies for the first frame of the clip only. - <i>all</i> generates proxies for each frame.	None

Supported Formats (-f option)

The following formats are supported by *imcopy*.

Image Format	Default Extension
Alias	als
Cineon	(none)
DPX	(none)
Pixar	picio
Pict	pict
JPEG	jpeg
SGI	sgi
Softimage	pic
Targa	tga
TdiMaya	iff
Tiff	tif
Wavefront	rla

Converting File Formats

To convert an image from one format to another using *imcopy*, you must specify which file to convert, where the file is located, the format it should be converted to, and where to store the file on output.

Syntax

```
imcopy -f <output format> <in file name and path> <out  
file name and path> <start index> <stop index>
```

Where:	Is:
<output format>	The file type of the output file.
<in file name and path>	The name of the file that you are inputting.
<out file name and path>	The name of the file that you are outputting.
<start index>	The start frame of the file.
<stop index>	The end frame of the file.

Example

```
imcopy -f tiff /usr/tmp/SGI/source%04d.sgi  
/usr/tmp/TIFF/dest%04d.tif 1 100
```

This operation converts the SGI images into TIFF images.

Input	Output
/usr/tmp/SGI/source0001.sgi	/usr/tmp/TIFF/source/dest0001.tif
/usr/tmp/SGI/source0002.sgi	/usr/tmp/TIFF/source/dest0002.tif
/usr/tmp/SGI/source0100.sgi	/usr/tmp/TIFF/source/dest0100.tif

Converting 10-bit Cineon Images

Digital film scans often consist of logarithmic data. Because Flame algorithms are optimized for linear data, a LUT is often used on import to convert the gamma and correct the logarithmic data for a linear data environment. Since Cineon images contain 10-bit logarithmic data, you need to use a LUT to convert the 10-bit logarithmic data to 8-, 10- or 12-bit linear. You can use one

of the LUTs provided, or create a custom LUT and use it with *imcopy* to import Cineon files directly into the framestore. See [Colour Management with LUTs](#) on page 729.

Extracting an Alpha Channel from an RGBA Image

You can use the `-x` option to extract the alpha channel from your RGBA image. The RGBA infile will be split into two RGB outfile; the *destination_alpha_filename* file will contain only the alpha channel of the *inRGBA_file*, and the *outRGB_file* will contain only the RGB components of the *inRGBA_file*.

NOTE The `-x` option expects an additional parameter. “`-x noinvert`” means that the alpha component will be extracted as is. “`-x invert`” will extract and invert the alpha component.

Syntax

```
imcopy -x noinvert <in RGBA file> <destination for RGB  
and alpha files> <start index> <stop index>
```

Where:	Is:
<in RGBA file>	The name of the file that you are inputting.
<destination for RGB and alpha files>	The name of the file that you are outputting.
<start index>	The start frame of the file.
<stop index>	The end frame of the file.

Example

```
imcopy -x noinvert /usr/tmp/SGI/source%04d.sgi  
/usr/discreet/clip/stonefs/NTSC/MyLib@myclip 1 100
```

This example takes the SGI RGBA images in the sequence and creates two clips in the *MyLib* library on the NTSC project of the framestore *stonefs*.

Input	Output
/usr/tmp/SGI/source0001.sgi	RGB in frame 1 of <i>myclip</i> , Alpha in frame 1 of <i>myclip_alpha</i>

Input	Output
<code>/usr/tmp/SGI/source0002.sgi</code>	RGB in frame 2 of <i>myclip</i> , Alpha in frame 2 of <i>myclip_alpha</i>
<code>/usr/tmp/SGI/source0100.sgi</code>	RGB in frame 100 of <i>myclip</i> , Alpha in frame 100 of <i>myclip_alpha</i>

On output, the clip *myclip* contains the RGB image, and the clip *myclip_alpha* contains the alpha channel of the original image.

Integrating an Alpha Channel into an RGB Image

You can use the `-a` option to combine an alpha (matte) infile and an RGB infile to produce an RGBA outfile.

NOTE When reading a matte from the RGB framestore, *imcopy* will only take information from the image's red channel.

Syntax

```
imcopy -a <in matte file> <in RGB file> <out RGBA file>
```

Where:	Is:
<in matte file>	The name and path of the source matte file.
<in RGB file>	The name and path of the source RGB file.
<out RGBA file>	The name of the result RGBA file.

Example

```
imcopy -a
/usr/discreet/clip/stonefs/NTSC/MyLib@myclip_alpha
/usr/discreet/clip/stonefs/NTSC/MyLib@myclip
/usr/tmp/SGI/dest%04d.sgi 1 100
```

This example takes the RGB data from *myclip* in the *MyLib* clip library in project *NTSC* on framestore *stonefs*, combines it with the matte clip *myclip_alpha*, and generates an SGI RGBA for the first 100 frames.

Input	Output
RGB from frame 1 of <i>myclip</i> and Alpha from frame 1 of <i>myclip_alpha</i>	<code>/usr/tmp/SGI/dest0001.sgi</code>
RGB from frame 2 of <i>myclip</i> and Alpha from frame 2 of <i>myclip_alpha</i>	<code>/usr/tmp/SGI/dest0002.sgi</code>
RGB from frame 100 of <i>myclip</i> and Alpha from frame 100 of <i>myclip_alpha</i>	<code>/usr/tmp/SGI/dest0100.sgi</code>

Cropping an Image

If you want to import a section of your source image only, you can specify the origin of this section with the `-o` (x position, y position) option. You can specify the size of this section with the `-s` (width, height) option.

The size of the internal buffer is specified with the `-d` (width, height) option. By default, the size of the internal buffer is the same as the width and height of the source image. If the buffer size differs from the source image, resize the selected rectangle from the source image into the internal buffer size using the `-k` (cropping type) option.

The `-q` option can be used to specify the quality of resizing: coarse, medium, quality or bicubic.

NOTE If you are importing an image to the framestore, the specified width and height parameters of the framestore are used to define the destination size of your image.

Cropping the Frames

You can crop the source frames using the `-k` option. The available options are as follows.

Option	Function
<code>-k crop</code>	Centres and crops the image. <code>-b r, g, b, or a</code> can be used to specify the colour for the cropped part of the image (default is black).

Option	Function
-k fit	Scales the longest edge to fit the frame size. Unused parts of the frame are filled with black.
-k fit-all	Scales the shortest edge to fit the frame size and crops the longest edge. The frame will be filled and part of the original image will be missing.
-k fit-both	Stretches or squeezes the image to fill the new resolution. This option scales the X and Y dimensions of the image non-proportionately to make it fit in the current frame. This changes the aspect ratio, which results in a distorted image.

Adjusting Bit Depths

By default, the internal buffer has a depth of 8 bits. If your source image has a depth greater than 8 bits, you should specify an internal buffer depth of 12 bits using the `-i 12` option to avoid truncating data to 8 bits per component. This changes the buffer depth from 8 bits to 12 bits.

Once the desired area of the source image has been cropped and resized and the bit depth has been converted into the internal buffer, the image is written to the destination. If the destination is an image file, the image file format will be the same as the input format. You can use the `-f` (image format) option to specify a different image format. By default, *imcopy* outputs images with 8-bit depth. Use the `-e` (bit depth) option to override the default setting.

Source Image Bit Depth	Option Parameter
16-bit (TIFF, SGI, Wavefront, Tdi/Maya)	-e 16
10-bit (Cineon, DPX)	-e 10

NOTE By default, if you write an image file with more than 8 bits per component into an 8-bit internal buffer, *imcopy* will only preserve the 8 most significant bits. To avoid this, specify an input LUT with the `-l` option to convert the source image bit depth to the internal buffer bit depth. For example, if using the default 8-bit internal buffer depth (`-i 8`), you could use the **10logto8** LUT provided. Or, for a 12-bit internal buffer depth (`-i 12`), you could use the **10logto12** LUT provided. See [Colour Management with LUTs](#) on page 729.

iminfo

Use the *iminfo* utility to obtain image information. This is useful if you want to quickly check information about an image file without entering the application. The following information is listed for the file:

- Image format
- Width and height
- Channel type, such as RGB
- Bit depth
- Compression type
- Orientation, such as top-to-bottom, left-to-right
- Timecode
- Number of the clip within a sequence and the total length of the sequence

To list the image file information:

- 1 Make sure `/usr/discreet/io/<version number>/bin` is in your path.
- 2 Type:
`iminfo`

Syntax

```
iminfo [-f] <format> <file path and name>
```

Where:	Is:
<format>	The format of the clip for which you want the information. The format for the file can be Alias, Cineon, Dpx, Jpeg, Pict, Pixar, Sgi, Softimage, Targa, Maya, Tiff, Wavefront, or Photoshop. The utility will return the image information more quickly if you provide the format.
<file path and name>	The file path and name of the clip for which you want the information.

Example

```
iminfo -f Jpeg /usr/tmp/girl.jpg
```

fcof

The find-clip-of-frame (*fcof*) utility scans all the libraries on the specified volume searching for clips referencing a given frame. The output tells you which clips use the frame and where they are located. When a large list of invalid frames is detected, it is usually more efficient to find the clip for a given frame, delete it, and perform another integrity check before searching for the next invalid frames. Very often all invalid frames are in the same few clips so finding affected clips for each invalid frame is unnecessary.

Syntax

```
fcof <framestore volume> <frameId> [-v]
```

Where:

Is:

<framestore
volume>

The volume to check (stonefs, stonefs1, stonefs2).

<frameID>

The frame's ID (0x1234abcd5678cdef).

Example

```
fcof stonefs 0x1234abcd5678cdef
```

fcof Options

The following option may be used with *fcof*.

Option

Function

-v

Enables additional verbosity

publishTool

Use the *publishTool* utility to publish clips from the shell using the Complex publish feature. See [Types of Publishing](#) on page 292.

NOTE You cannot use the *publishTool* utility to perform a Simple or Flatten publish.

To start *publishTool*:

1 Make sure `/usr/discreet/io/<version number>/bin` is in your path.

2 Type:

```
publishTool <options> <source clip path>  
<destination library> <destination path>
```

Syntax

```
publishTool [-f <output file format>] [-m <output  
compression>] [-v] [-j <jpeg compression factor>] [-o  
<output file name format>] [-n <maximum number of source  
handles>] [-L] [-U <uid>] <source clip path>  
<destination library> <destination path>
```

<source clip path> has the syntax:

```
<project path>/<library name>@<desktop>/<reel>/<clip  
name>@<clip creation date>
```

<clip creation date> has the format "YYYY/MM/DD hh:mm:ss".

Examples

```
publishTool -f sgi -U H_0000054367_S_0000065473_U_00234  
/mnt/NAS/910/clip/stonefs/bluelune@mydesktop/myreel  
juneclips /usr/tmp
```

```
publishTool  
/usr/discreet/clip/stonefs/MyProject/MyLibrary@MyClip@"2009/01/01  
12:12:12" MyPublishedClips /usr/discreet/published
```

publishTool Options

The following options may be used with *publishTool*.

Option	Function	Default
-f	Sets the output file format. Possible values are Alias, Cineon, Dpx, Jpeg, Pict, Pixar, Sgi, Softimage, Targa, Maya, Tiff, Wavefront, Photoshop.	Dpx
-m	Sets the compression. Possible values are def (Default), none, rle (Runlength-encoded), and lzw (Lempel-Ziv & Welch).	None
-v	Turns verbose mode on.	Verbose mode is off.
-j	Sets the JPEG compression factor. Possible values are from 0 - 100.	50
-o	Sets the output file name format.	.%04d (where 4 means use 4 digits and 0 means use 0 as a placeholder where applicable)
-n	Sets the maximum number of handles for the source clip to keep.	60
-L	Creates soft links to the image files instead of making copies, if the media is already soft-imported and in the same file format.	Off
-U	Specifies the unique ID (UID) of the source clip. You can use this instead of the clip name and creation date to retrieve the source clip. This is useful when you need to distinguish between two or more source clips with the same name and creation date. Use <i>cmtool</i> to determine the UID of a clip; the UID appears in the clip ID column when you list the contents of a library. It has the format H_0000000000_S_0000000000_U_00000. If you use this option, you omit the <clip name> and <clip creation date> in the <source clip path>.	Off

stonifiseTool

Use the *stonifiseTool* utility to write clips to the framestore.

To start *stonifise*:

- 1 Make sure `/usr/discreet/io/<version number>/bin` is in your path.
- 2 Type:
stonifiseTool <option> <source clip path>
<destination library name>

Syntax

stonifiseTool [-v] [-U <uid>] <source clip path>
<destination library name>

<source clip path> has the syntax:

<project path>/<clip library name>@<clip name>@<clip
creation date>

<clip creation date> has the format "YYYY/MM/DD hh:mm:ss".

Examples

```
stonifiseTool -v  
/usr/discreet/clip/stonefs/experience/juneclips@flowers@"2009/07/06  
13:12:36" augustclips  
  
stonifiseTool -U H_0070054367_S_0008065473_U_00265  
/mnt/NAS/910/clip/stonefs/bluelune@mydesktop/myreel  
juneclips
```

stonifiseTool Options

The following option may be used with *stonifiseTool*.

Op- tion	Function	Default
-v	Turns on verbose mode.	Verbose mode is off.

Option	Function	Default
-U	Specifies the unique ID (UID) of the source clip. You can use this instead of the clip name and creation date to retrieve the source clip. This is useful when you need to distinguish between two or more source clips with the same name and creation date. Use <i>cmtool</i> to determine the UID of a clip; the UID appears in the clip ID column when you list the contents of a library. It has the format H_0000000000_S_0000000000_U_00000. If you use this option, you omit <clip name> and <clip creation date> in <source clip path>.	Off

vstat

The *vstat* utility provides statistics on usage of storage. It lists the projects, number of full resolution frames, number of proxy frames, and number of megabytes of audio. It also lists the size of the volume and the amount of space used and available.

Volume statistics are also available in Flame from the Preferences menu.

Syntax

```
vstat -v <volume> [-l] [-d] <verbose level>
```

Where:	Is:
<volume>	The name of the volume. For example: <i>stonefs</i> .
<verbose level>	Value for the reporting level.

Example

```
vstat -v stonefs -d 2
```

vstat Options

The following option may be used with *vstat*.

Option:	Function:	Default
-v	Determines the volume for which statistics are returned.	None
-l	Library mode. Displays the number of frames used per project and per library. If you add the number of frames for each library together, the total is usually less than the total number of frames per project. Each frame is counted for the project, but duplicate frames are only counted once for libraries.	None
-d	Sets the reporting level (0, 1, 2) where 0 provides essential information, 1 provides important information, and 2 provides informative information.	1

vic

Use *vic*, the command line integrity checking tool, to correct media referencing errors. For example, if a frame is used in two libraries, but it only has one reference count on the framestore, this is an error. The *vic* utility corrects the reference count.

Syntax

```
vic [-h]  
vic -v <volume> [-d <verbose level>] [-l] [-C] [-p  
<project name>] [-f] [-w]
```

Example

```
vic -v stonefs1 -d 2
```

vic Options

The following options may be used with *vic*.

Option	Function	Default
-h	Displays the usage syntax.	
-a	Checks all volumes currently available.	
-v	Specifies volume to check (stonefs, stonefs1, stonefs2).	
-d	Sets the verbosity or “reporting” level (0, 1, 2) where 0 provides essential information, 1 provides important information, and 2 provides informative information.	2
-l	“Lazy” mode. Will not decrement the reference count on a framestore.	
-C	Validates volume connections only. No content check is performed.	
-p	Specifies the project where Lost+_Found would be created, in case unreferenced frames are found.	
-f	Deletes unreferenced material; that is, it frees up material that would normally be placed in Lost+_Found. Use with caution.	
-w	Will skip integrity checking of audio waverforms.	
-r	Activates repair mode. This option enables vic to search the media library and replace missing frame ids with a LOST frame label. In the library, the names of impacted clips appear red. When these clips are loaded into the record timeline, the names of the affected segments also appear red. Lost frames are displayed with the LOST label over them. The flag set on clips is not permanent, so resaving the clip will remove the red from the names.	

Command Line Start-up and Exit Options

37

Topics in this chapter:

- [Starting Flame](#) on page 919
- [Exiting Flame](#) on page 923
- [Initialising the Tablet](#) on page 923
- [Killing Processes](#) on page 923

Starting Flame

If you are running Flame for the first time, make sure you have correctly installed and configured the application. There are several start-up options you can use to specify a particular setup or to enable a customized configuration.

To start Flame:

- 1 Log in to the *Flame* user account at your workstation.
- 2 Do one of the following:
 - To start Flame normally, double-click the application's icon on the workstation's desktop.

- To start Flame using start-up options, open a shell, and then type: **flame** - <option>. See [Start-up Options](#) on page 920.

After a few moments, the Project Management menu appears.

- 3 Select the project and user you want to use or create new ones. See [Managing Projects and Users](#) on page 521.
- 4 Click Start.

The application has finished loading when you see the yellow cross cursor, and the message “Startup Complete” appears.

NOTE Flame will not start if your system disk does not have enough space available. The system disk must have enough free space to accommodate the largest clip library plus an additional 10 MB.

- 5 Tap the pen, click the mouse, or press **Enter** to display the Desktop.

Start-up Options

There are a number of start-up options that you can use with the **flame** command under special circumstances. More than one start-up option can be specified on the command line. These start-up options are case-sensitive.

You can see an on-screen list of these start-up options by typing:

```
flame -H
```

NOTE The **flame -H** command does not launch the application.

Framestore-Related Start-up Options

WARNING When you use the **-v** option, all framestore data will be deleted with no possibility of recovery.

Type:	To:
flame -v	Initialise the framestore volume (all projects).
flame -H	Specify the remote host name.
flame -V	Specify the framestore name.
flame -i	Remove all clips from the project.

Type:	To:
flame -r	Initialise only the Desktop for the selected project.
flame --red-frames	Activate repair mode. This option enables vic to search the media library and replace missing frame ids with a LOST frame label. In the library, the names of impacted clips appear red. When these clips are loaded into the record timeline, the names of the affected segments also appear red. Lost frames are displayed with the LOST label over them. The flag set on clips is not permanent, so resaving the clip will remove the red from the names.

Audio sources are stored on the framestore, so initialising the framestore also removes all audio clips from the project.

Project Management-Related Start-up Options

Type:	To:
flame -c <file-name .cfg>	Use a configuration file other than the default, where <file-name .cfg> is the name of the file. The specified file supersedes the default configuration file. If you do not use the option, Flame looks first for <i>init.cfg</i> , and if that is not found, it looks for <i>flame.cfg</i> .
flame -J <project>	Define the project that appears in the Project Management menu when you start Flame, where <project> is the name of the project you want to use. If you start Flame with both the -J and -U options, Flame bypasses the Project Management menu.
flame -U <user>	Define the user that appears in the Project Management menu when you start Flame, where <user> is the name of the user you want to use. If you start Flame with both the -J and -U options, Flame bypasses the Project Management menu.

Miscellaneous Start-up Options

Type:	To:
flame -m	Initialise the mouse only (not the tablet and pen).
flame -F	Force Flame to install new fonts that you added to the directory <i>/usr/lib/DPS/outline/base</i> (and <i>/usr/lib/DPS/AFM</i> if you have also installed the corresponding font metric file). See Installing Fonts on page 873.

Type:	To:
flame -B	Prevent the broadcast monitor from blanking when an image viewer or Player is not displayed. The broadcast monitor then displays the screen content that is displayed in the corresponding region. This option is hardware dependent and may not work on all hardware configurations.
flame -L	Disable writing to the <i>.log</i> file. Flame keeps a log file of your actions in a text file (<i>.log</i>) in your Flame home directory. Usually this file is cleared and recreated every time Flame is started. (Note that the log file is useful when reporting problems to Customer Support.)
flame -l	Append the current session to the existing log file. (See description of the log file above.)
flame -M	Define the amount of memory assigned to frame buffering. This option overrides the default settings, or if it has been uncommen- ted, the value set by the MemoryApplication keyword in the file <i>init.cfg</i> .
flame -p <n>	On multi-processor machines, start Flame using less than the full array of processors, where <n> is the number of processors to be used. Normally, Flame uses all available processors.
flame -f <filename>	Use a custom menu file, where <filename> is the name of the menu file. For information on custom menus, see Creating Custom Menus on page 832.
flame -J <project> -U <user> -b <batch_setup> -N	Launch Flame and specify a Batch setup to render. Flame launches, renders the setup, and exits. Use the -N option only if you want to use Burn for rendering. To avoid corrupting the render, which uses the graphics hardware, you should not use the graphics console of the system (such as command shells) while the render is taking place.
flame -Z	Starts Flame and skips the integrity check.

Exiting Flame

Click the Exit command in the Preferences menu to exit the current work session and save the status of the Desktop and current menu preferences. Alternatively, press **Alt+F12** or **Shift+Insert** from any menu.

Initialising the Tablet

If you use the pen and tablet while the application is starting, the tablet will fail to initialise. Press **Shift+T+Insert** to initialise the tablet if it does not function during a work session.

Killing Processes

If Flame hangs but you can still interact with the operating system, you must use either the kill alias defined in the Flame `.cshrc` file or the `kill` command in conjunction with the individual process IDs.

WARNING These kill procedures should not be used to exit Flame unless the application is hung or otherwise not responding. Killing processes indiscriminately can cause system problems. Under normal conditions, you should use one of the exit procedures described in [Exiting Flame](#) on page 923.

Killing All Flame-Related Processes

The `.cshrc` file that comes with your Flame system contains the alias `kf` which can be used to kill all Flame processes at once.

To kill all Flame-related processes:

- 1 In a shell, type `kf`.

To verify that all Flame-related processes have been killed:

- 1 Type `ps -fu <flame account name>`.

This command displays information about all active processes, including the application with which each process is associated, and a process ID number. If all Flame processes have been successfully killed, this command should return no results.

Never restart Flame if there are still Flame processes left over from a previous session. If some Flame processes persist after using the kill alias, you must kill them independently.

Killing Processes Individually

Use the **kill** command to kill processes individually, using their process ID number.

To use the kill command to kill processes individually:

1 Press **Alt+F3** to send Flame to the background.

2 Open a shell.

3 At the command line in the shell, type:

```
ps -fu<flame account name>
```

This command displays information about all active processes, including the application with which each process is associated, and a process ID number.

4 Determine the process ID number for Flame.

5 At the command line, type:

```
kill <process number>
```

where <process number> is the process number you determined in step 4. This command terminates the Flame process that is currently executing.

NOTE There may be more than one Flame process running at any time. For example, there may be one process per CPU, plus some additional processes to manage the framestore. You should kill each of these processes.

You can now restart Flame.

Part 8: Editing

Part 8 includes these chapters:

- [Editing Essentials](#) on page 927
- [Editing on the Desktop](#) on page 935
- [Navigating the Timeline](#) on page 969
- [Editing to the Batch Timeline](#) on page 1015
- [Vertical Editing](#) on page 1035
- [Trimming Shots](#) on page 1045
- [Dissolves and Wipes](#) on page 1065
- [Soft Effects](#) on page 1111
- [Timewarps](#) on page 1153
- [Managing Timeline Media](#) on page 1179
- [Audio](#) on page 1195



Image courtesy of Creative Bubble

Topics in this chapter:

- [Introduction](#) on page 927
- [About Desktop Editing](#) on page 928
- [About Player Timeline Editing](#) on page 928
- [About Batch Timeline Editing](#) on page 928
- [Editing Operations Table](#) on page 929
- [Basic Editing Concepts](#) on page 930

Introduction

In Flame you can perform editing operations on the desktop and on the timeline in both the Player and Batch. Some operations can be performed in all three places—for example, creating a dissolve or adding a cut to a clip. Edits that you apply to a clip in one area can be modified in either of the other areas wherever the type of operation is supported. For example, a dissolve applied to clips on the desktop can be modified in the Batch timeline.

The area you select depends on the complexity of the required edit. This chapter provides guidelines on which area to use, and the types of operations you can perform in each area.

About Desktop Editing

Use the desktop to apply simple edits to clips on the desktop reels, such as cutting a clip into two clips or adding a timewarp to a clip. When editing on the desktop, you can use either commands in the Editing menu or gestural cursor movements. You can perform operations on single clips, such as reversing the order of frames in a clip, and on two clips, for example, splicing two clips together. The desktop is useful for quickly applying straightforward edits to clips.

See [Editing on the Desktop](#) on page 935.

About Player Timeline Editing

Like the desktop, the timeline in the Player is convenient for quickly performing simple edits. You can trim both video and audio as well as cut a clip in two. However, you can only bring a single clip, which may be composed of one or more shots, into the Player's timeline. You cannot perform any edits that involve combining two clips or inserting frames from one clip into another.

You can create and edit transitions on shots already on the timeline. You can also create soft effects from the Player timeline. You cannot create soft effects through desktop editing.

For information on basic timeline functionality, see [Navigating the Timeline](#) on page 969.

About Batch Timeline Editing

The timeline in Batch provides an integrated, visual environment where you can easily edit video and audio elements, and work with an edit sequence. The Batch timeline can have multiple video and audio tracks. You can use the timeline to edit single clips or to create edited sequences involving any number of source clips.

Use the Batch timeline in any of the following situations:

- You want to apply simple edits to individual clips that you will be using in a Batch process tree.
- You are creating effects for one or more shots that are part of a pre-assembled clip. Using the timeline, you can extract those shots, apply

the effects, then replace the original shots in the sequence with the new shots. See [Starting with an Assembled Clip](#) on page 1017.

- Your project involves assembling several shots together, adding transitions, and syncing video and audio. The timeline provides all the editing tools needed for such complex projects.
- You want to edit audio separately from video, or edit individual audio tracks.

See [Batch Timeline Workflow](#) on page 1016.

Editing Operations Table

The following table indicates the editing operations you can perform on the desktop, Player timeline, and Batch timeline.

Editing Operation	Desktop	Player Timeline	Batch Timeline
Cutting clips	X	X	X
Splicing two clips together	X		X
Inserting a complete or partial clip into another clip	X		X
Replacing frames in one clip with material from another clip	X		X
Replacing an entire shot with material from another clip	X		X
Trimming clips		X	X
Adding and modifying timewarps	X	X	X
Adding and editing soft effects		X	X
Adding and editing Batch FX			X
Adding and editing dissolves	X	X	X
Repeating one or more frames in a clip	X		
Reversing the order of frames in a clip	X		

Editing Operation	Desktop	Player Timeline	Batch Timeline
Matching a clip with its source clip(s)	X		X
Consolidating clips	X	X	X
Committing clips	X	X	X
Rendering clips	X	X	X

Basic Editing Concepts

This section explains key editing concepts that apply whether you are working on the desktop, the Player timeline, or the Batch timeline.

Soft Edits

When you apply an edit such as a splice or dissolve to a clip, you can modify the edit afterwards. A modifiable edit is referred to as a “soft edit,” and a clip containing one or more soft edits is referred to as a “soft clip.” You can modify a soft edit because the application retains information on the steps and source clips involved in its creation. For example, if you use the Dissolve command to dissolve between two source clips, the result is a soft edit. You can modify the parameters of the dissolve any time.

The Splice, Dissolve, Insert, Replace, and Timewarp commands of the Editing menu, as well as all gestural edits performed on the desktop or timelines, generate soft edits. In the timeline, all edits applied to clips are soft edits.

To create soft edits on the desktop, you must enable the Soft Edits button in the Desktop Editing section of the Preferences menu. If it is not enabled, the resulting edit will not be modifiable. On the desktop, soft edits are marked by a “[E]” label on the proxies. In Batch, clips in the schematic that contain soft edits applied in the timeline are indicated with “[E]” following the clip name.

There are four kinds of soft edits: soft cuts, soft transitions, soft timewarps, and soft cutouts.

Soft Cuts

A *cut* is an edit that divides one clip into two clips. On the desktop, the two new clips are referred to as *cutouts*. In the timeline, a cut divides a segment into two segments. When you split a clip in two using the Cut command in

the Editing menu, or gesturally, you have the option of retaining the frames cut from each clip as head and tail frames (creating soft cuts), or removing them. Enable the Soft Cuts button in the Desktop Editing section of the Preferences menu to keep the head and tail frames when you cut a clip.

NOTE You can only use the Soft Cuts option when the Soft Edit button is enabled.

Soft Transitions

When you perform an edit that involves joining two clips together, the resulting clip is composed of two *shots* (which were the original two clips before the edit) and a junction between the two shots, called a *transition*. Soft transitions include splices and dissolves. The shot before the transition is the outgoing shot and the shot after the transition is the incoming shot.

In a dissolve, the outgoing shot is the shot that fades out, and the incoming shot is the shot that fades in. The outgoing shot, incoming shot, and the blending transition are all elements of the edit sequence.

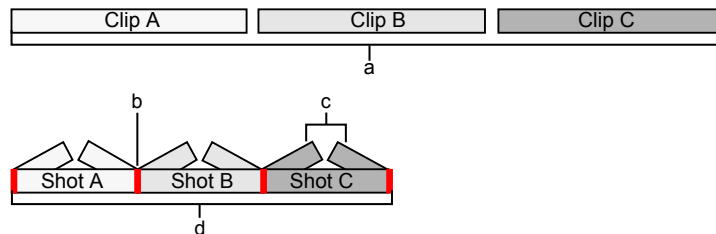

(a) Clips (b) Soft Transition (c) Head and tail frames (available for trimming) (d) Edit sequence

On the desktop, soft transitions in expanded clips are characterized by yellow transition handles that mark where the two clips have been joined, for example, splice, insert, and replace edits, or green brackets that delimit the frames in a transition, for example, a dissolve. On desktop clips containing dissolves, the label $D(n / m)$ is also displayed, where n is the frame's position in the dissolve and m is the length of the dissolve.

In the Batch and Player timeline, each shot, referred to as a *segment*, appears as a rectangle, and a selected splice between two segments appears as a vertical yellow bar. Transitions are indicated by icons. See [Creating Dissolves on the Timeline](#) on page 1078.

Soft Timewarps

A timewarp is a soft edit that changes the timing of a clip. Soft timewarps are created with the Timewarp command on the desktop, and in Batch and the

Player timeline using a keyboard command or soft effect button. On the desktop, all frames in a timewarped or reversed soft edit are identified with the “TW” label. In the Batch and Player timeline, the TW label appears in the segment information.

Soft Cutouts

On the desktop, soft cutouts are created by cutting a soft edit, and are identified by a “[” label. Like soft cuts, soft cutouts can be modified.

Committing Soft Clips

Once you have finished editing a clip, you can make the soft edits a permanent part of the clip so that they are no longer modifiable. This is referred to as *committing* the clip. If a clip contains several shots, the shots are permanently joined together. Dissolves are no longer modifiable and head and tail frames are removed. It is not necessary to commit a soft clip prior to outputting a clip using the Output Clip menu or before exporting it.

To commit soft clips on the desktop, use the Commit command in the Editing menu. In Batch, you can commit selected segments in the timeline or the entire timeline.

Source Clip

A source clip is either a clip loaded from a VTR or a clip created in Flame. It is the clip that provides source material to another clip in a two-clip editing operation.

Target Clip and Record Clip

In two-clip editing operations, *target clip* and *record clip* refer to the clip that receives material from a source clip. Target clip refers to a clip that receives material in operations that involve the creation of a third clip containing the result of the edit. The original two clips used in the operation are left intact. Many desktop editing commands use this method. A record clip, by comparison, is always the resulting soft clip. For example, when hot keys are used to perform insert or overwrite edits in the Batch timeline, the record clip receives material from the source clip, and becomes the new soft clip.

Timecode on Soft Clips

You can view two types of timecode on clips on the desktop, Player timeline and Batch timeline—source timecode and record timecode.

The timecode for the source clip is used in the soft edit. A source clip can be captured from a VTR, imported, or created in Flame. Source clips loaded from a VTR start with the timecode from the VTR tape. Source clips created in Flame or imported begin at timecode 00:00:00:00.

The record timecode is the timecode of the soft edit. When you use an editing command that creates a soft edit, the record timecode shows a new timecode renumbered starting at 00:00:00:00.

To view source and record timecode on the desktop, select Src and Rec Timecode from the Frame ID box in the Desktop Clips section of the Preferences menu. See [Desktop Preferences](#) on page 848. In the Batch or Player timeline, display the element information. See [Displaying Element Information](#) on page 987.

Keycode on Soft Clips

You can display keycode information on clips. See [Displaying Timecode and Keycode](#) on page 405.

Using Virtual Sources in the Timeline

When you create a clip using the Colour Source command or create a clip composed of identical frames using the Repeat command, you can use the clip as a virtual source in the timeline. A virtual source is a clip that has no real beginning or end, meaning that you can trim, slip or slide it to any extent. For example, if you insert a colour source clip consisting of 10 frames into the edit sequence, you can trim, slip or slide the clip by any number of frames.

Head and tail information for virtual sources is indicated by an asterisk (*).

Topics in this chapter:

- [About Editing on the Desktop](#) on page 935
- [Accessing the Editing Menu](#) on page 937
- [Gestural Editing on the Desktop](#) on page 939
- [Cutting Clips](#) on page 943
- [Splicing Clips](#) on page 948
- [Inserting Frames and Clips](#) on page 951
- [Replacing Frames and Clips](#) on page 954
- [Matching Soft Clips with Their Source Clips](#) on page 956
- [Repeating Frames in a Clip](#) on page 958
- [Reversing Frame Order in a Clip](#) on page 959
- [Swapping Shots](#) on page 961
- [Consolidating Clips](#) on page 963
- [Committing Soft Clips](#) on page 965
- [Force Rendering Clips](#) on page 966

About Editing on the Desktop

You can apply many types of edits to clips on the desktop—splitting clips, splicing clips together, adding dissolves and timewarps.

Editing functions such as splicing clips create soft edits, which you can modify any time until you commit them. Soft edits created on the desktop can be brought into the timeline in either the Player or Batch for further manipulation.

Some desktop editing operations can be accomplished in two ways—by using menu commands and by using drag and drop gestures with the mouse or stylus. For these cases, this chapter describes both methods.

Most desktop editing operations can be performed on either collapsed or uncollapsed clips. The procedures in this chapter are for uncollapsed clips. For collapsed clips, you must select your in point, out point, and target frames by scrubbing through the collapsed clip until the desired frame is visible. For information, see [Collapsing and Expanding Clips](#) on page 48.

You can also perform certain editing functions in the Player timeline and in the Batch timeline. For recommendations on which editing tool to use for different purposes, see [Editing Essentials](#) on page 927.

Editing Multiple-Resolution Clips

Editing operations that are performed on more than one clip, such as splicing two clips together, can only be done on clips of the same resolution, aspect ratio, and bit depth. For most editing operations involving two clips, if you attempt to use clips of differing resolutions, a menu appears that gives you the option of either resizing the source clip to the resolution of the destination clip or aborting the edit.



(a) Fit Method box

To resize a source clip to the destination clip resolution:

- 1 Select a Fit method. For information on Fit Method options, see [Destination Settings](#) on page 682.
- 2 Click Hard Resize or Soft Resize.

Accessing the Editing Menu

Desktop editing commands are found in the Editing menu. To access the Editing menu, click the Editing button in the Main menu.

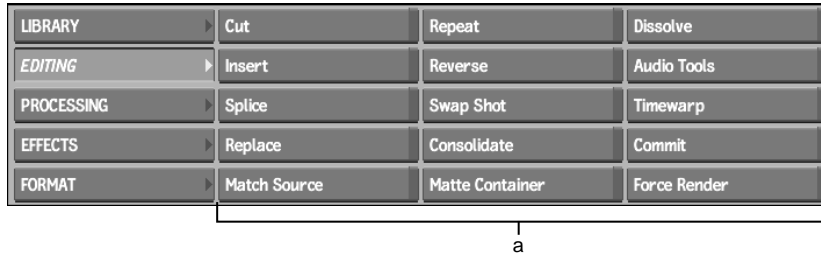

LIBRARY	Cut	Repeat	Dissolve
EDITING	Insert	Reverse	Audio Tools
PROCESSING	Splice	Swap Shot	Timewarp
EFFECTS	Replace	Consolidate	Commit
FORMAT	Match Source	Matte Container	Force Render

(a) Editing menu

The Editing commands are described as follows. They all support OpenEXR-formatted clips except Reverse, Matte Container, and Audio Tools.

NOTE All editing operations apply to audio as well as video unless otherwise noted.

Cut Divides a single clip into two or more clips. Select a frame in the source clip and the clip is cut after the selected frame. See [Cutting Clips](#) on page 943.

Insert Inserts a partial or complete source clip after a specified frame in the target clip. The Insert command creates a soft edit. See [Inserting Frames and Clips](#) on page 951.

Splice Splices two or more source clips together. Select the frames in the two source clips where the splice is made. The Splice command creates a soft edit. See [Splicing Clips](#) on page 948.

Replace Replaces frames in the target clip with a partial or complete source clip. The Replace command creates a soft edit. See [Replacing Frames and Clips](#) on page 954.

Match Source Finds matching frames in source clips or matches a soft clip with its source clip. See [Matching Soft Clips with Their Source Clips](#) on page 956.

Repeat Repeats a frame, a clip, or the frames in a clip any number of times. The repeated frames or clips are joined end to end to make a new clip. See [Repeating Frames in a Clip](#) on page 958.

Reverse Reverses the order of the frames in a clip. See [Reversing Frame Order in a Clip](#) on page 959.

Swap Shot Replaces a shot between two transitions, or between a transition and the start or end of a soft edit. See [Swapping Shots](#) on page 961.

Consolidate Removes head and tail frames (handles) from one or more clips. You can specify a number of handles to retain. See [Consolidating Clips](#) on page 963.

NOTE Consolidate does not apply to audio.

Matte Container Creates a container for a front and matte clip. You can choose to only contain the clips or to contain them and add an Axis, which adds transparency between the clips. You can edit the container directly in the timeline. See [Working with Containers](#) on page 1041.

Dissolve Fades between two source clips (dissolve or crossfade), or one source clip and a black source (fade-in or fade-out). You can also mix clips together. The Dissolve command creates a soft edit. See [Creating Dissolves on the Desktop](#) on page 1066. Dissolves can also be applied to audio.

Audio Tools Create a timewarp for audio or mix down audio. See [Audio](#) on page 1195.

Timewarp Changes the overall timing in a clip. You can create complex timing changes or add an image trail to a clip with the Timewarp Editor. The Timewarp command creates a soft edit. See [Creating Timewarps on the Desktop](#) on page 1154.

NOTE The Timewarp command does not apply to audio. To timewarp audio, use Audio Timestretch. See [Audio Timewarp](#) on page 1219.

Commit Commits a soft edit. See [Committing Soft Clips](#) on page 932.

Force Render Renders a clip, all the clips on a reel, or all the clips on the desktop. See [Force Rendering Clips](#) on page 966.

NOTE Force Render does not apply to audio.

Most editing commands remain in the command mode after performing the operation—allowing you to perform it again if needed. To cancel the mode, click anywhere in the grey area below the desktop reels, or click on any other menu option.

For information on the clip management commands (such as Copy, Name and Move) in the last column of the Editing menu, see [The Desktop](#) on page 31.

Gestural Editing on the Desktop





Gestural editing is a technique in which you use your mouse or stylus to move clips among reels on the desktop, and to perform cut, copy, insert, splice, and replace edits.

To edit gesturally, select Gestural Editing in the Desktop section of the Preferences menu.

Gestural Editing Cursors

When you drag a source clip over a target clip, the cursor changes as the source clip moves over different areas of the target clip. The type of cursor indicates the type of edit that occurs when you drop the source clip on that spot.

All gestural splices and insert and replace edits ripple the edit sequence, and may change the duration of the target clip. The exception to this rule is when you replace a clip with another clip of the same duration.

Cursor:	Appears when:	Use to:
 Insert	The source clip is positioned between frames on the target clip.	Perform an insert edit.
 Replace	The source clip is grabbed at any frame other than its first or last frame, and is positioned over a frame on the target clip.	Perform a replace edit. You cannot gesturally replace frames with a two-frame clip. However, you can perform this type of edit with a one-frame clip.
 Replace ahead	The source clip is grabbed at its first frame and is positioned directly over a frame on the target clip.	Perform a replace edit starting at the frame under the cursor and moving in the direction of the arrow.
 Replace back	The source clip is grabbed at its last frame and is positioned directly over a frame on the target clip.	Perform a replace edit starting at the frame under the cursor and moving in the direction of the arrow.

To perform a gestural insert or replace edit:

- 1 Drag the source clip over the frame in the target clip where you want to make the edit until you see the appropriate edit cursor.



- 2 Drop the source clip.

The clip is updated with the edit. The source clip replaces the frames of the target clip



Editing Video and Audio Simultaneously

When you edit a clip that has both video and audio tracks, you can specify if you want both the video and audio or just the video to be affected by the edit.

The following sections explain how to enable and disable the editing of audio simultaneously with video for both gestural and command-based editing, and the results with various types of edits.

Specifying Tracks for Gestural Editing

Many gestural edits can be applied to both video and audio. The desktop contains the Audio Follows Video box, which you use to specify whether you want the edit to be applied to video or both video and audio.



(a) Audio Follows Video box

To apply the edit only to video:

- 1 Select Edit Video from the Audio Follows Video box.
Only video is affected by the edit.

To apply the edit to video and audio:

- 1 Select Edit Video & Audio from the Audio Follows Video box.
The video and both audio tracks are edited simultaneously.

TIP Press **A** to temporarily change the status of the Audio Follows Video box for the current gestural edit.

You can also enable or disable Audio Follows Video in the Desktop Preferences menu.

The following table explains which editing functions are affected by the status of the Audio Follows Video button.

Function	Audio Follows Video Enabled	Audio Follows Video Disabled
Cut	Cuts are placed in audio tracks at the same location as the video track, and the same portions are removed.	Audio tracks are not cut and the complete audio tracks appear on both parts of the clip.
Splice	Splice points are created in audio tracks at the same location as in the video track. If the source clip does not contain audio, the target clip's audio is overwritten with silence.	Audio in the target clip is unaffected; audio on the source clip is ignored.
Insert	Splice points are created in audio tracks at the same location as in the video track. If the source clip does not contain audio, the target clip's audio is overwritten with silence.	Audio in the target clip is unaffected; audio on the source clip is ignored.
Replace	Splice points are created in audio tracks at the same location as in the video track. If the source clip does not contain audio, the target clip's audio is overwritten with silence.	Audio in the target clip is unaffected; audio on the source clip is ignored.

Specifying Tracks for Command-Based Editing

Many editing commands can be applied to both video and audio. The applicable menus contain an Video/Audio option box for specifying whether the command is applied to video or both video and audio.

To specify tracks for editing commands:

- 1 Select an option from the Video/Audio box.



The following table explains how editing functions are affected by the status of the Video/Audio box.

Function	Video & Audio Option Enabled	Video Option Enabled
Cut	Audio tracks are cut at the same location as the video.	Audio tracks and timing remain intact on both parts of the clip.
Insert	Insertion is performed in all tracks. If the source clip does not contain audio, the target clip's audio is overwritten with silence.	Audio in the target clip is unaffected; audio in the source clip is ignored.
Splice	Splice points are created in audio tracks at the same location as in the video track. If the source clip does not contain audio, the target clip's audio is overwritten with silence.	Audio in the outgoing clip is kept.
Replace	Splice points are created in audio tracks at the same location as in the video track. If the source clip does not contain audio, the target clip's audio is overwritten with silence.	Audio in the target clip is unaffected; audio in the source clip is ignored.
Swap Shot	The portion of audio intersecting the shot being swapped in is carried over.	Audio in the target clip is unaffected; audio in the source clip is ignored.

Function	Video & Audio Option Enabled	Video Option Enabled
Dissolve	Audio in the incoming and outgoing clips is dissolved in sync with video.	Audio in the outgoing clip is unaffected; audio in the incoming clip is ignored.
Copy (Range/Frame)	Only audio in the selected range is copied.	The complete audio tracks are copied regardless of the selected range.
Move (Range/Frame)	Only audio in the selected range is moved. Cuts are inserted on the source clip for video and audio tracks at the frames delimited by the range selection.	The complete audio tracks are moved, regardless of the selected range. The source clip is unaffected.
Delete (Range/Frame)	Only audio in the selected range is deleted.	All audio is deleted, regardless of the selected range.

Cutting Clips

You can split a clip into two or more clips using the Cut command. When you cut a clip, you can retain the cut frames as head and tail frames (handles) on each resulting clip, creating a soft clip, or you can discard the frames. To use this command, enable Soft Cuts in the Desktop Preferences menu.

In the Editing menu, click Cut to display the Cut menu.



(a) Cut Mode option box (b) Video/Audio box

The Cut Mode options are described as follows.

Select:	To cut the clip:
After Selected Frame	After the frame that you select when in Cut mode.
At Splices	At every soft splice that occurs on the clip.
Every Nth Frame	At the intervals that you specify in the numeric field that appears when you select this option.

To cut a clip after the selected frame:

- 1 Click Cut in the Editing menu.
- 2 Select After Selected Frame from the Cut Mode option box.
- 3 Select the frame before the place where you want to make the cut in the source clip.

The clip is divided into two cuts after the selected frame. The frames in the second clip are renumbered starting at frame number 00001.



Action: Select the source clip

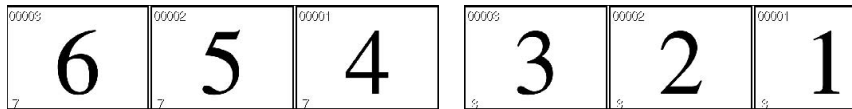

Result: The clip is cut between the third and fourth frames

To cut a clip at every Nth frame:

- 1 Click Cut in the Editing menu.
- 2 Select Every Nth Frame from the Cut Mode option box.
- 3 Enter the number of frames to be contained in each cut in the Frame Number field.
- 4 Select the source clip.

The clip is cut into segments of the selected number of frames.

To cut a clip at its splices:

- 1 Click Cut in the Editing menu.
- 2 Select At Splices from the Cut Mode option box.
- 3 Select the source clip.

The clip is cut into segments at every soft splice point. If the clip contained no soft splices, no cuts are made.

Cutting Dissolves and Timewarps

Performing a cut on an uncommitted dissolve or timewarp divides the soft edit into two soft cuts.

If the cut is performed on a frame within a dissolve, the dissolve is committed before the cut is made. The two resulting cuts are soft edits linked to the original source clips.

If the cut is performed on a frame within a timewarp, two clips with unrendered timewarps are created.

NOTE You should commit a soft cutout before saving it to the clip library or an archive to avoid saving the soft cutout's source clip. See [Committing Soft Clips](#) on page 965.

Cutting Clips with Audio Tracks

When you cut a clip with audio, use the Video/Audio box to specify how the audio is affected.



(a) Video/Audio box

Select:	To:
Video & Audio	Cut the audio tracks at the same location as the video.
Video	Include the entire audio tracks on both new clips. The audio tracks are not cut.

See [Editing Video and Audio Simultaneously](#) on page 940 for more information.

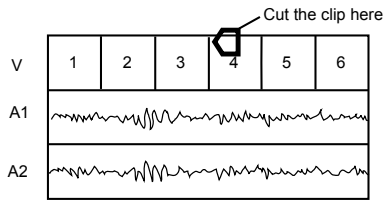

Video & Audio option selected

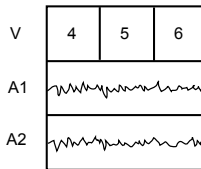
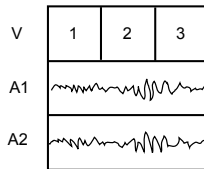

Video option selected

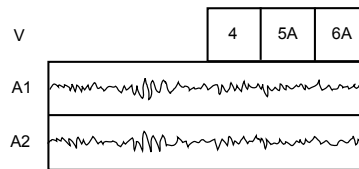
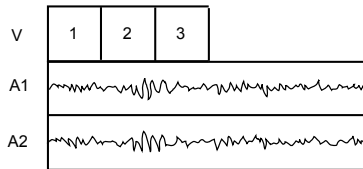

Cutting Clips Gesturally

When gestural editing is enabled, each frame in a clip contains two types of "hot spots". The Move Clip hot spot is the part of the clip that is used to move clips around on the desktop. The Cut Clip hot spots are the parts of the clips that are used to cut the clip.

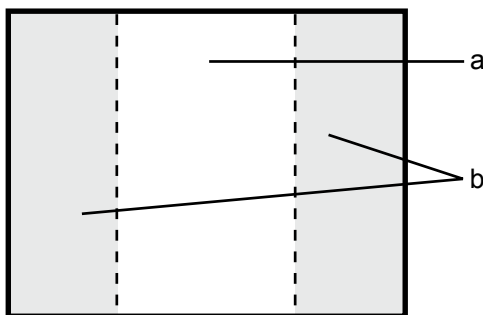

(a) Move Clip hot spot (b) Cut Clip hot spots

To cut a clip gesturally:

- 1 Position the cursor over the frame where you want to make the cut. Place the cursor in the Cut Clip hot spot on the frame edge closest to the cutting point.
- 2 Grab the frame and drag up or down to cut it from the clip.
- 3 Drop it in another location on a reel.

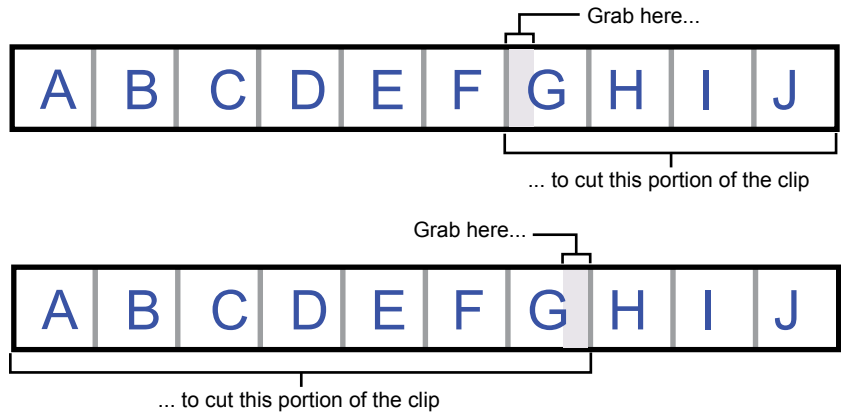

Cutting Audio Gesturally

When you gesturally cut a clip with audio, use the Audio Follows Video box to specify how audio is affected.

Select:	To:
Edit Video & Audio	Cut the audio tracks at the same location as the video.
Edit Video	Include the entire audio tracks on both new clips. The audio tracks are not cut.

The result is the same as cutting a clip from the Editing menu. See the illustration in [Cutting Clips with Audio Tracks](#) on page 945.

Splicing Clips

You can join together either two source clips or all the clips on a reel. This creates a single clip with a soft edit (a splice) at the location where the clips were joined.

To display the Splice menu, click Splice in the Editing menu.

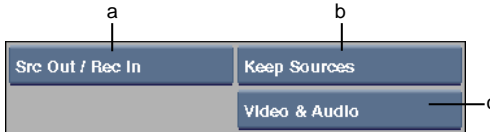

(a) Splice Type box (b) Sources box (c) Video/Audio box

To splice two clips together:

- 1 Click Splice in the Editing menu.
- 2 Select Src Out/Rec In from the Splice Type box.
- 3 From the Sources box, select Keep Sources to keep the source clips or select Delete Sources to remove them from the desktop after creating the splice.
- 4 Select Video & Audio or Video from the Video/Audio box. See [Splicing Clips with Audio](#) on page 950.
- 5 In the source clip, select the last frame before the splice. The frames from the beginning of the clip up to and including the selected frame will be contained in the new clip.
- 6 In the record clip, select the first frame after the splice. The frames from the selected frame up to the last frame in the clip will be contained in the new clip.
- 7 Select the destination reel.

The two clips are spliced together to form a clip that is added to the destination reel. A yellow transition handle indicates where the two clips were spliced together. To remove the yellow handle, commit the clip. See [Committing Soft Clips](#) on page 965.

If you are showing source and record timecode, the first timecode (left) is the original timecode of each source clip. The second timecode (right) is a new timecode for the splice starting at the record in timecode of the outgoing clip. For more information, see [Timecode on Soft Clips](#) on page 933.

After creating the splice, the cursor reverts to a red arrow so that you can repeat the Splice command using another set of clips.

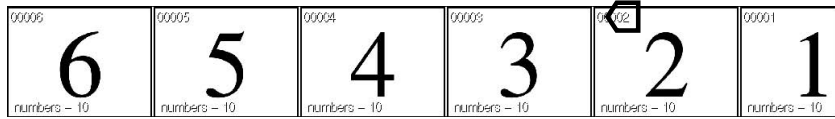

Action: In the source clip, select the last frame before the splice



Action: In the record clip, select the first frame after the splice



Result: The clips are spliced together

To splice together all clips on a reel:

- 1 Click Splice in the Editing menu.
- 2 Select Reel from the Splice Type box.
- 3 From the Sources box, select Keep Sources to keep the source clips or select Delete Sources to remove them from the desktop after creating the splice.
- 4 Select the reel containing the clips you want to splice together.
- 5 Select the destination reel.

All clips on the reel are spliced together into one clip and placed on the destination reel.

Yellow transition handles indicate where the clips were spliced together. To remove the yellow handle, commit the clip. See [Committing Soft Clips](#) on page 965.

Splicing Clips with Audio

When you splice two clips with audio, use the Video/Audio box to specify how the audio is affected.

Select:	To:
Video & Audio	Splice the audio at the same location as the video. If the source clip has no audio tracks, the target clip's audio tracks are overwritten with silence.
Video	Ignore the audio tracks in the source clip. The audio tracks on the target clip are unaffected.

See [Editing Video and Audio Simultaneously](#) on page 940 for more information.

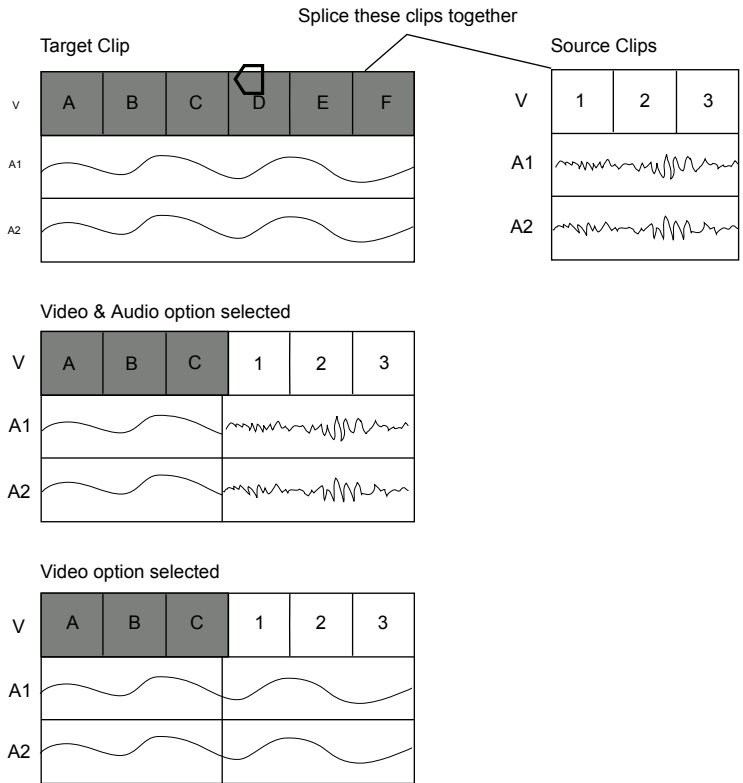

Inserting Frames and Clips

You can insert a source clip or a portion of a source clip after a frame in the target clip. The option you select in the Insert Mode option box determines whether you insert frames or clips.

To display the Insert menu, click Insert in the Editing menu.



(a) Insert Mode option box

Select:	To:
Src In/Out Rec In	Insert a portion of the source clip after the selected frame in the target clip. See Inserting Frames on page 951.
Clip	Insert the source clip after a selected frame in the target clip. This is the default mode, which is reset between Flame sessions. See Inserting Clips on page 952.

Inserting Frames

You can insert a portion of a source clip after a selected frame in the target clip.

To insert frames:

- 1 Click Insert in the Editing menu.
- 2 Select Src In/Out Rec In from the Insert Mode option box.
- 3 Select the in point of the source clip (the starting frame of the segment that you want to insert).
- 4 Select the out point of the source clip (the ending frame of the segment that you want to insert).
- 5 Select an in point frame in the target clip.

The frames between the in point and out point of the source clip are inserted after the selected frame (the in point) in the target clip. The remaining frames of the target clip are placed at the end of the inserted frames.

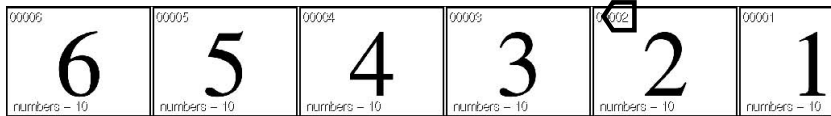

Action: Select the in point of the source clip

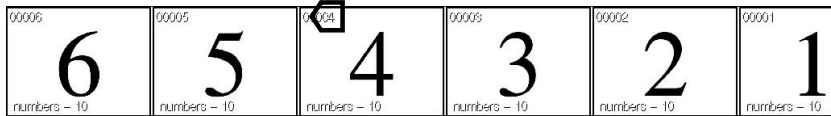

Action: Select the out point of the source clip

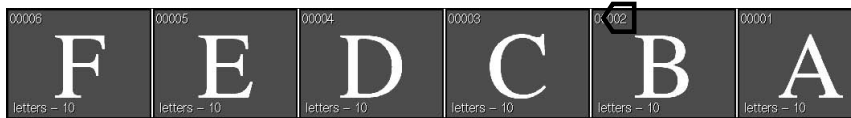

Action: Select an in point frame on the target clip

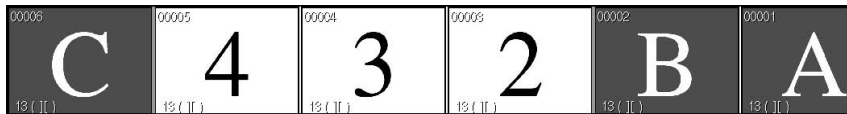

Result: The selected frames are inserted into the target clip

Inserting Clips

You can insert an entire clip after a selected frame in the target clip.

To insert a clip:

- 1 Click Insert in the Editing menu.
- 2 Select Clip from the Insert Mode option box.
- 3 Select the source clip.
- 4 Select an insertion-point frame in the target clip.

The source clip is inserted after the selected frame in the target clip. The remaining frames of the target clip are placed at the end of the inserted clip.

Inserting Clips with Audio

When you insert a clip with audio, use the Video/Audio box to specify how the audio is affected.

Select:	To:
Video & Audio	Insert the source audio tracks along with the video, overwriting the target audio tracks. If the source clip has no audio tracks, the portion of the audio tracks corresponding to the inserted frames on the target clip is overwritten with silence.
Video	Ignore the audio tracks in the source clip. The audio tracks on the target clip are unaffected.

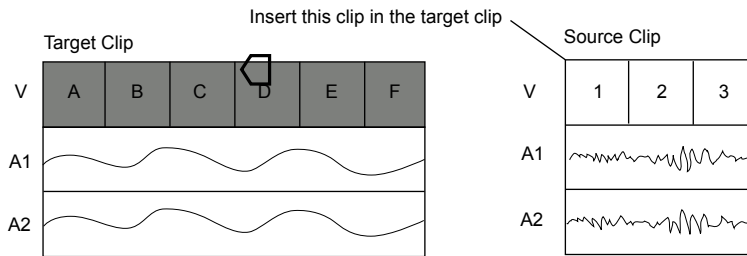

Video & Audio option selected

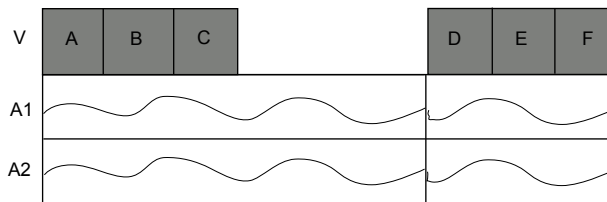

Video option selected

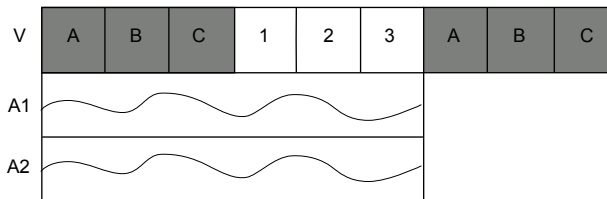

Replacing Frames and Clips

You can replace frames in the target clip with a source clip or with frames from a source clip. The option you select in the Replace Mode box determines whether you are replacing frames with a series of frames or an entire clip.

To display the Replace menu, click Replace in the Editing menu.



(a) Replace Mode box (b) Video/Audio box

Select:	To:
Src In/Out Rec In	Replace frames in the target clip with a portion of the source clip. See Replacing Frames on page 954.
Clip	Replace frames in the target clip with the source clip. This is the default mode, which is reset between Flame sessions. See Replacing Clips on page 955.

Replacing Frames

You can replace frames in a target clip with frames from a source clip.

To replace frames:

- 1 Click Replace in the Editing menu.
- 2 Select Src In/Out Rec In from the Replace Mode box that appears.
- 3 Select the in point of the source clip. The in point is the first frame of the segment that you want to insert.
- 4 Select the out point of the source clip. The out point is the last frame of the segment that you want to insert.
- 5 Select a frame in the target clip.

The frames after and including the selected frame in the target clip are replaced by the frames between the in point and out point of the source clip. An example is shown as follows.

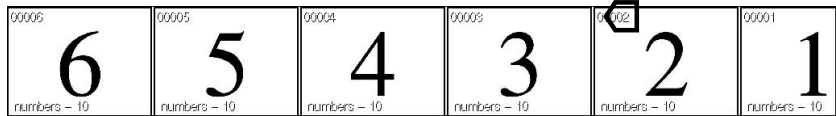

Action: Select the in point of the source clip

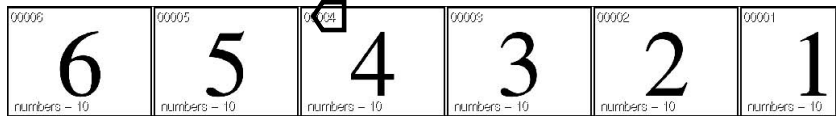

Action: Select the out point of the source clip



Action: Select an in point frame on the target clip

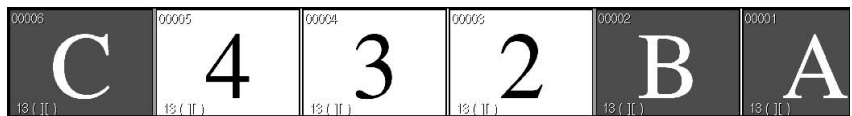

Result: The selected frames replace frames in the target clip

Replacing Clips

You can replace frames in a clip with an entire source clip.

To replace frames with a clip:

- 1 Click Replace in the Editing menu.
- 2 Select Clip from the Replace Mode box that appears.

- 3 Select an audio option.

Select:	To:
Video & Audio	Replace the audio in the specified frames in the target clip with audio from the source clip. If the source clip contains no audio tracks, the audio in the target clip is overwritten with silence.
Video	Retain the audio in the target clip.

- 4 Select the source clip.
- 5 Select a frame in the target clip.

The source clip replaces the frames after and including the selected frame in the target clip.

Matching Soft Clips with Their Source Clips

Matched sources are the original, untrimmed clips with their original names and timecode information. When working with soft clips, use the Match Source menu to:

- Create a copy on the desktop of the source clip(s) used to create a soft clip.
- Locate the original frame in a source clip for any frame in a soft edit.

Matching is possible because Flame keeps a history of all clips used to create a soft edit and is always able to find a source clip in a soft edit's history. You can specify if Flame will search the desktop and the clip library for the original source, or just the desktop when matching to the original source.

You specify an option using the Search Location box in the Match menu. To display the Match menu, click Match Source in the Editing menu.



(a) Search Location box (b) Match Type box

If you select Desktop, only clips on the desktop are searched. Limiting the search to the desktop is useful if you have many large local clip libraries as they may greatly increase the time taken to locate the original source clip. When matching frames, if the original source cannot be found, a new source

is created on the desktop that contains only the material for which you are searching. However, the newly created clip will not contain the original clip name or record timecode information.

If you select Desktop & Library, the desktop is searched first for the original source. If the original source is not found, all local clip libraries are searched. Searching both the desktop and the clip libraries increases the likelihood of finding the original source but may also result in longer search times with large clip libraries. If the original source is not found either on the desktop or in the clip library, a new source is created on the desktop that contains only the material for which you are searching. However, the newly created clip will not contain the original clip name or record timecode information.

If you are matching a single-element clip that has been trimmed, the Match Source will create a new clip on the desktop with no head and tail frames. The head and tail frames are instead included as part of the new clip. The new clip has the original name and record timecode information.

To create a copy of a soft clip's source clips on the desktop:

- 1 Click Match Source in the Editing menu.
- 2 Select either Desktop or Desktop & Library from the Search Location box.
- 3 Select Clip from the Match Type box.
- 4 Select the soft clip you want to match.

The desktop and history of the soft edit clip are searched to locate the original source for that frame and the cursor becomes a white arrow.

- 5 Select a destination reel.

A new copy of the source clip(s) appear, and a message indicates the name and location of the clip it matches. This clip is a copy of the original source, with its original name.

To match a frame in a soft clip:

- 1 Click Match Source in the Editing menu.
- 2 Select either Desktop or Desktop & Library from the Search Location box.
- 3 Select Element from the Match Type box.
- 4 Select the frame of the soft edit that you want to match.

The desktop and history of the soft edit clip are searched to locate the original source for that frame:

- If the source is on the desktop, it is centred on its reel, and a message indicates the location of the matched source.
- If the source is not on the desktop, the cursor becomes a white arrow.

5 If the cursor is a white arrow, select a destination reel.

A new clip appears, and a message indicates its name and location. This clip is a copy of the original source, with its original name.

Repeating Frames in a Clip

You can make copies of a single frame, an entire clip, or each frame in a selected clip, and join the repeated frames or clips end-to-end.

To repeat frames:

1 Click Repeat in the Editing menu.

The Repeat menu appears.

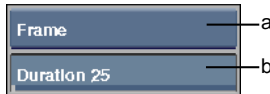

(a) Repeat Mode box (b) Repeat Number field

2 Select the type of item that you want to repeat from the Repeat Mode box.

Select:	To repeat:
Frame	A single frame. The frames are joined end-to-end to produce one new clip.
Clip	An entire clip. The clips are joined end-to-end to produce one new clip.
Frames in Clip	Each frame in a clip. For example, if you set the number of repetitions to three, the result clip contains the first frame repeated three times, followed by the second frame repeated three times, and so on.

- 3 Enter the number of times that you want to repeat the frame or clip in the Repeat Number field. For the following examples, the Repeat Number is set to 3.
- 4 Select either the clip or the frame that you want to repeat.
- 5 Select the destination reel.

A new clip containing the repeated frame(s) or clip appears and is added to the destination reel.

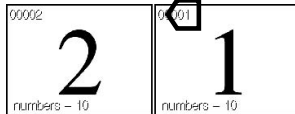

Action: Select the source clip or frame



Result: Repeating a frame

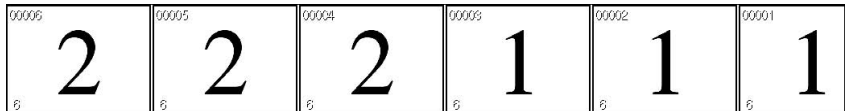

Result: Repeating the frames in a clip

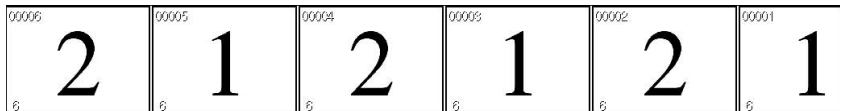

Result: Repeating the clip

Reversing Frame Order in a Clip

You can reverse the order of frames in a clip.

To reverse the order of frames in a clip:

- 1 Click Reverse in the Editing menu.



(a) **Soft Reverse** button (b) **Progressive/Interlaced** box (c) **Interpolation** box

- 2 If you want to save space on your framestore and only process later, enable Soft Reverse.
- 3 Select Progressive or Interlaced render from the Progressive/Interlaced box.
- 4 If you selected Interlaced, set the interpolation.

Select:	To:
No Interpolation	Create a clip with no field interpolation.
Half Interpolation	Create a clip in which interpolation only takes place on displaced fields.
Full Interpolation	Create a clip in which all fields are interpolated. Note that this option has the least aliasing, but you may notice some softening of the image due to the blending of the fields.
Shift Up	Shift the image up a single line. This may help reduce artefacts that can appear.
Shift Down	Shift the image down a single line. This may help reduce artefacts that can appear.

- 5 Select the source clip.
- 6 Select the destination reel.
A new clip in which the order of frames is reversed appears on the destination reel.

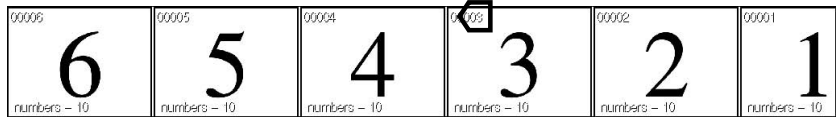

Action: Select the source clip (frame 3 in example)

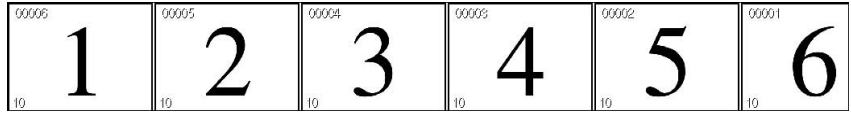

Result: The order of the frames is reversed

Swapping Shots

You can replace a shot between two soft edit transitions, or between a transition and the start or end of a soft edit.

To swap a shot in a soft edit:

- 1 Click Swap Shot in the Editing menu.
The Shot and Force Render boxes appear.



(a) Shot box (b) Force Render box (c) Video/Audio box

- 2 If you are swapping a shot in a dissolve, use the Shot box to select between swapping the outgoing or incoming shot when clicking on a frame in the dissolve.
- 3 Select the align frame in the source clip.
The align frame is used to align the source clip and shot being swapped.
- 4 Select the align frame in the shot that you want to swap.
The shot and source clip are lined up, using the align frames, then swapped. If there are not enough frames before or after the align frame in the source clip to fit before or after the align frame in the selected shot,

the error message “Selected Shot Does Not Fit at Destination” appears in the message bar.

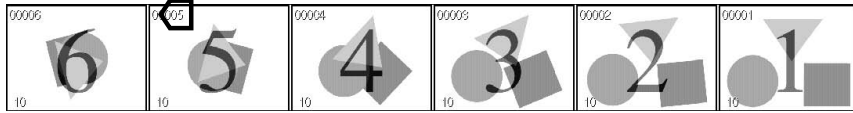

Action: Select the align frame in the source clip that will swap the shot (frame 5 in example)

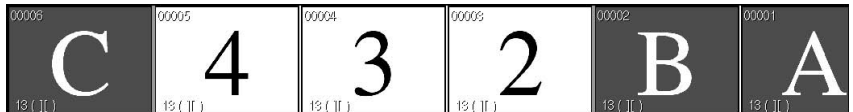

Action: Select the align frame in the shot you want to replace (frame 3 in example)

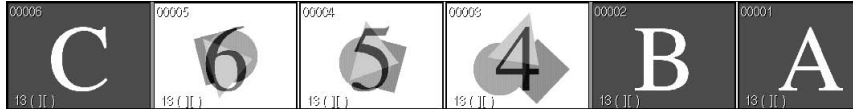

Result: The shot is swapped with the source clip

Swapping Shots with Audio

When you swap a clip with audio, use the Video/Audio box to specify how the audio is affected.

Select:	To:
Video & Audio	Overwrite the target audio tracks with the source audio tracks. If the source clip has no audio tracks, the target clip's audio tracks are overwritten with silence.
Video	Ignore the audio tracks in the source clip. The audio tracks on the target clip are unaffected.

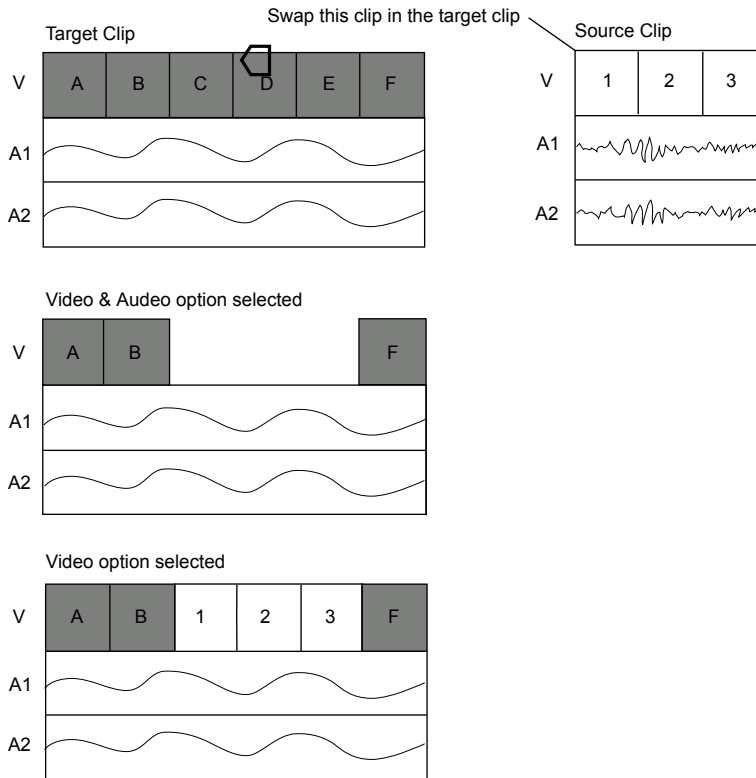

Consolidating Clips

Use the Consolidate menu to permanently remove head and tail frames (handles) from a clip—and from the framestore, freeing up space on it. You can keep a number of the existing handles by specifying an upper handles limit before consolidating the clip. For example, if you have a clip with 40 head frames and 10 tail frames, and you consolidate it with a value of 15, the resulting clip has 15 head frames and 10 tail frames.

TIP You can undo a Consolidate command but only prior to entering a module or the Player. For information on undoing commands on the desktop, see [Undoing and Redoing Operations](#) on page 68.

You may want to consolidate clips with a large number of heads and tails before archiving to avoid archiving unused material.

Use the Consolidate menu to consolidate:

- A clip
- All the clips on a reel
- All the clips on the desktop
- An element (soft edit) on a clip
- A range of elements on a clip

NOTE You can also consolidate clips from the clip library.

Consolidate does not apply to audio.

To remove head and tail frames from a clip:

- 1 Click Consolidate in the Editing menu.
The Consolidate menu appears.

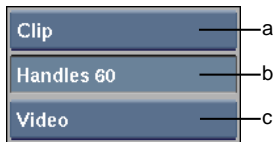

(a) Item Type box (b) Track box (c) Handles box

- 2 Select the type of item you want to consolidate from the Item Type box.
- 3 Enter the number of handles to keep in the Handles field.
- 4 Specify which tracks to consolidate in the Tracks box.
- 5 Select the item you are consolidating.

To select: **Click:**

A clip The clip with the red cursor that appears.

A reel Anywhere on the reel.

The desktop The Confirm button.

An element The frame immediately before the element.

To select:	Click:
A range	The start of the range with the red arrow cursor and the end of the range with the green arrow cursor.

Committing Soft Clips

Use the Commit command to convert a soft clip to a source clip. This removes the clip's soft properties, meaning it no longer “remembers” the source clips used to create it. When you commit a clip, head and tail frames are also removed. If elements such as timewarps or dissolves have not been rendered, they are automatically rendered before the commit.

Commit a soft clip when you archive the clip or when you have completed the edit. Using the Commit command you can commit:

- All the soft edits in a clip
- All the soft edits on a reel
- All the soft edits on the desktop
- All the soft edits in a range that you select
- Just the audio tracks

WARNING Once a soft edit is committed, its links to source clips cannot be re-established.

To commit one or more clips:

- 1 Click Commit in the Editing menu.
- 2 Select the type of item you want to commit from the Commit option box.

NOTE When you select Audio, you can specify if you want to commit the audio tracks on a selected clip, on all the clips on a reel, or on all the clips on the desktop.

3 Select the item you want to commit.

To select:	Click:
A clip	The clip with the red arrow cursor that appears.
A reel	Anywhere on the reel.
The desktop	The Confirm button.
An element	The frame immediately before the element.
A range	The start of the range with the red arrow cursor and the end of the range with the green arrow cursor.
Audio	The clip, reel, or Confirm button, depending on if you selected Clip, Reel or Desktop.

When the commit is complete, the cursor changes from the “busy” cursor to a red selection cursor, allowing you to select another clip to commit.

Force Rendering Clips

A soft edit may need to be rendered if it is the result of an aborted timewarp or dissolve. Soft edits that need to be rendered contain one or more frames displaying the message “Unrendered Frame”. You re-render, or force render, a clip using the Force Render command. You can force render clips that are locked.

Use the Force Render command to render:

- A range of transitions or timewarps in a soft edit
- A single transition or timewarp in a soft edit
- An entire soft edit
- All the soft edits on a reel
- All the soft edits on the desktop
- Dissolves created in Unrendered mode
- Unrendered Batch FX

Frames on the desktop containing unrendered Batch FX display the message “UNRENDERED FRAME Batch.” See [Managing Edited Clips in Batch](#) on page 1188.

Force Rendering a Range of Frames

You can force render all transitions or timewarps within a specified range of frames.

To force render a range of frames:

- 1 Click Force Render in the Editing menu.
- 2 Select Range from the Force Render option box that appears.
- 3 Select the starting frame in the soft edit.
- 4 Select the ending frame in the soft edit.

The transitions or timewarps within or which cross the selected range of frames are force rendered.

Force Rendering a Single Dissolve or Timewarp

You can force render a single dissolve or timewarp in a soft edit.

To force render a single dissolve or timewarp:

- 1 Click Force Render in the Editing menu.
- 2 Select Element from the Force Render option box that appears.
- 3 Select a frame within the dissolve or timewarp that you want to force render.

The selected dissolve or timewarp is force rendered.

Force Rendering Entire Soft Clips

You can force render an entire soft clip, all soft clips on a reel, or all soft clips on the desktop.

To force render entire soft clips:

- 1 Click Force Render in the Editing menu.
- 2 Select Clip, Reel, or Desktop from the Force Render option box that appears.
- 3 Select a clip, a clip on a reel, or any clip on the desktop.
The selected item is rendered.

Navigating the Timeline

40

Topics in this chapter:

- [About Timelines](#) on page 969
- [Accessing the Timeline](#) on page 970
- [Timeline Interface](#) on page 971
- [Manipulating the Timeline](#) on page 972
- [Playing the Timeline](#) on page 975
- [Track Basics](#) on page 978
- [Element Basics](#) on page 983
- [Searching for Timeline Elements](#) on page 989
- [Maintaining Sync between Elements](#) on page 992
- [Patching Video and Audio Channels](#) on page 997
- [Setting In Points and Out Points](#) on page 1003
- [Marking Frames of Interest](#) on page 1007
- [Creating a Cut](#) on page 1011
- [Swapping Batch Timeline Elements](#) on page 1012
- [Matching Elements with Their Source Clip](#) on page 1013

About Timelines

The timeline environment enhances the editing process by providing tools that allow you to work with all the video and audio elements of your sequence without leaving the Batch module.

When editing to the timeline, you are not restricted to using video or images of a particular frame rate or resolution. When you record a clip in a non-native project resolution to the timeline, the clip is automatically resized. You can continue to apply Resize options such as letterbox or cropping. When creating Batch FX, the output resolution is based on the timeline resolution and not the project resolution.

Also see [Working with Audio in the Timeline](#) on page 1204.

Accessing the Timeline

You can access the timeline of any clip brought into Batch using the Desk or Library node. Clips brought in using the Import node are not supported on the timeline.

From the main Batch timeline, you can access the timeline of individual clips to create Batch FX.

To access the timeline of a Batch clip:

- 1 Bring a clip into Batch.
- 2 If the node bin is displayed, double-click the clip. Otherwise, select the clip.

NOTE If you double-click a clip while the Clip Edit menus are displayed, you return to the desktop for clip selection.

- 3 Click Timeline.

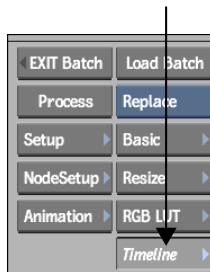

The selected clip's timeline appears.

Timeline Interface

Timelines can contain multiple video and audio tracks. An edit sequence on a track is made of segments and transitions. Video and audio segments appear as a series of rectangles on their associated tracks. Transitions appear as cuts or icons between segments.

Video tracks can be made up of multiple layers. Layers are used to stack video vertically to create composite effects and transitions. If you have more than one layer or track, the positioner's focus point indicates which one is current.

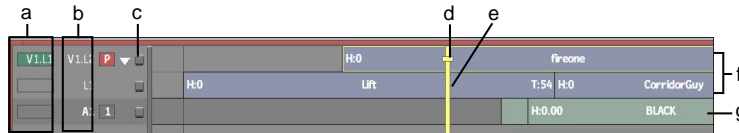

(a) Patch identifiers (b) Track identifiers (c) Selector icon (d) Focus point (e) Positioner (f) Video track made up of two layers (g) Audio track made up of one layer

Positioner Is the “playhead” for playing the clip. The frame directly beneath the positioner is displayed in the viewport or is the current location for an edit such as a dissolve or cut.

Focus point Indicates the current track. In vertical editing, the positioner's focus point indicates the top layer (focus layer) in the vertical edit.

Patch and track identifiers Indicate patching for video and audio tracks. See [Patching Video and Audio Channels](#) on page 997.

Selector icon Click to select a layer or track.

Track Contains the segments and transitions that you edit together.

Layer Used for vertical editing and timeline compositing. See [Vertical Editing](#) on page 1035.

Element Refers to the video segments, audio segments, and transitions that make up an edit sequence. Elements are colour coded to make them easier to identify, as illustrated in the following table. Coloured bars on top of the elements indicate their process and lock status. See [Identifying the Status of Timeline Effects](#) on page 1180.

This interface component: Is:



A video segment. By default, this segment is pale blue. It represents a video clip in the edit sequence.

This interface component: Is:



A container. By default, this element is dark blue. It represents a container in the edit sequence.



A matte container element. By default, this element is a purplish hue. It represents a container that holds a fill and matte.

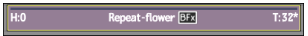

A segment containing a Batch setup. By default, this element is pale magenta.

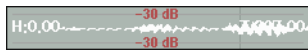

An audio segment. By default, this segment is pale green. It represents an audio clip in the edit sequence.



An element with unlinked audio.



A dissolve transition.



A wipe transition.



A custom transition.



An axis transition.

Manipulating the Timeline

As the complexity of your timeline increases, you may need to see some parts in more detail than others. You can control the area displayed by panning, zooming, and scrolling. As well, you can display an enlarged view of the timeline.

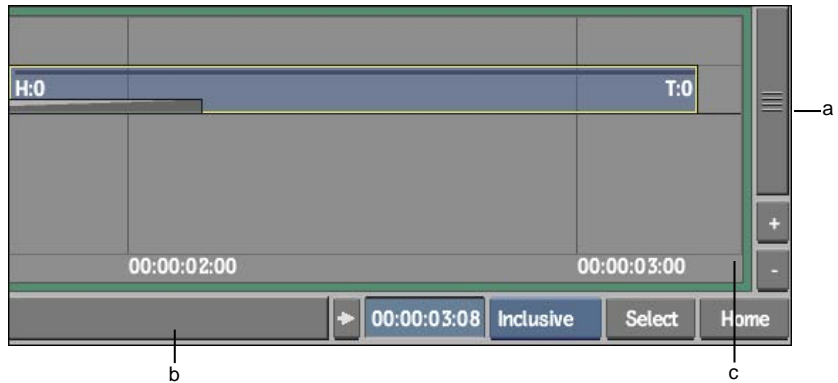

(a) Vertical scroll bar (b) Horizontal scroll bar (c) Right timeline viewing area

Moving the Timeline Display

Move to a particular area of the timeline by panning or scrolling.

To scroll left or right:

- 1 Do one of the following:
 - Drag the horizontal scroll bar in the direction you want to scroll.
 - Hold the positioner against the right or left side of the timeline viewing area.

TIP You can change the speed at which the timeline scrolls when you hold the positioner against either side of the timeline. See [Timeline](#) on page 841.

To scroll up or down:

- 1 Drag the vertical scroll bar in the direction you want to scroll.

To pan:

- 1 Hold down **spacebar**.
- 2 Drag the hand cursor in the direction you want to pan.

Zooming the Timeline

Zoom in or out of the timeline to control the level of detail displayed.

To zoom in horizontally:

- 1 Do one of the following:
 - Drag the horizontal scroll bar up.
 - Hold down **Shift+spacebar** and drag the magnifying glass cursor to the left.

To zoom in vertically:

- 1 Do one of the following:
 - Click the  zoom control.
 - Drag the vertical scroll bar to the left.

To zoom out horizontally:

- 1 Do one of the following:
 - Drag the horizontal scroll bar down.
 - Hold down **Shift+spacebar** and drag the magnifying glass cursor to the right.

To zoom out vertically:

- 1 Do one of the following:
 - Click the  zoom control.
 - Drag the vertical scroll bar to the right.

To zoom into a selected area:

- 1 Do one of the following:
 - Hold down **Ctrl+spacebar** and draw a box around the area of interest with the magnifying glass cursor.
The view zooms into the area inside the box.

- Select an area or move the positioner over the area you want to zoom and then click Select.
The view zooms in horizontally on the current selection.

TIP To return to the previous settings, click Select a second time.

To return to the default timeline coordinates:

- 1 Click Home.

TIP To return to the previous settings, click Home a second time.

Displaying a Large Timeline View

If you have more tracks or layers than can be displayed simultaneously, you can display a large view of the timeline.

To display a large view of the timeline:

- 1 Press **Ctrl** and swipe the bar at the bottom of the screen.



The schematic is resized to fit into the remaining space on the Batch desktop.

TIP To return to the regular timeline view, **Ctrl**-swipe again.

Playing the Timeline

You can control how the timeline plays back. For example, frame-step through a shot to isolate a frame or jump to the start of an element to play a specific shot. The image window updates as the positioner moves on the timeline.

If the Player is displayed, you can use any of the playback controls to move through the timeline. See [Controlling Playback in the Player](#) on page 96.

To play the timeline:

- 1 Press **enter**.

NOTE If you enabled Playback Scroll in the Timeline section of the Preferences menu, frames might be dropped.

To stop playback:

- 1 Press **spacebar**.

Scrubbing the Timeline

Use the scrub area to move quickly to any location on the timeline.

You can also scrub audio. See [Scrubbing Audio in the Timeline](#) on page 1205.

To scrub the timeline:

- 1 Drag left or right in the scrub area.

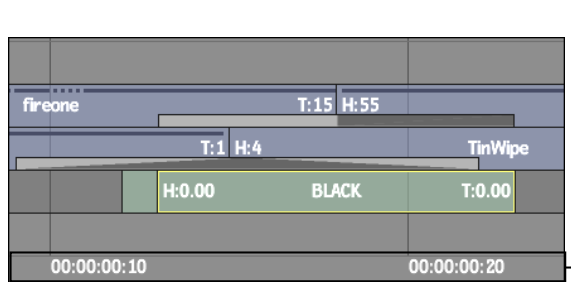

Jumping to a Particular Location

If you want to go to a particular timecode or frame, you can have the positioner jump to that location on the timeline.

To jump to a particular location:

- 1 Do one of the following:
 - Click the scrub bar at a particular location.

- Enter a value in the Current Timecode field.

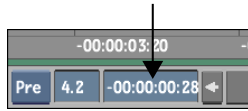

NOTE To enter a frame number instead of timecode, click the field to bring up the numeric keypad. Click TC to change to FRM, and then enter a frame number.

Jumping between Elements

You can jump from one cut to another on any layer or track.

To jump between elements:

- 1 Do any of the following.

To jump to:	Press:
The next transition on the current layer	N
The previous transition on the current layer	B
The next transition on any layer or track	Shift+N

Frame-Stepping the Timeline

To isolate a specific frame, move the positioner frame by frame through the timeline.

To frame-step the timeline:

- 1 Press the **left** or **right arrow** key.

Track Basics

The timeline supports multiple video and audio tracks. Having multiple video tracks on the same timeline is useful for quick access to different versions of your work.

For information on working with audio tracks, see [Working with Audio in the Timeline](#) on page 1204.

Adding Tracks



You can add as many audio and video tracks to a timeline as you want. Video tracks can have multiple layers.

To add a track to the timeline:

- 1 Select and enable Editing from the Menu Priority box.



- 2 Do one of the following:

- To add a video track above the current track, click .
- To add a video track below the current track, **Ctrl**+click .
- To add an audio track, click .

To remove a track from the timeline:

- 1 Click the Selector icon, drag it to the bottom of the screen and release when the cursor changes to a green recycling icon.

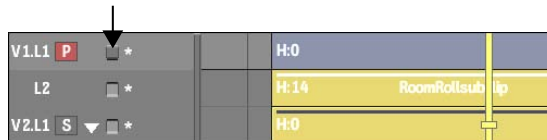

To move a track to another location on the timeline:

- 1 Drag the Selector icon to a new location on the timeline.

Activating a Track's Output

Although you can add as many audio and video tracks as you want, only 1 video track can have an active output channel, and up to 32 audio tracks can be mapped to input strips on the AudioDesk.

To activate a track's output:

- 1 Click the respective track's output indicator.

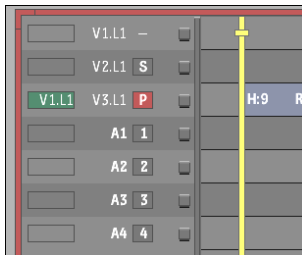

The inactive symbol (--) changes as follows:

- If you activated a video output channel, a “P” appears indicating it is the Primary video track. The previously active video output channel is deactivated.
- If you activated an audio track's output indicator, a number between 1 and 32 appears. You can assign an audio track to any of the 32 input strips on the AudioDesk by clicking the indicator and dragging left or right.

Changing the Current Track

Editing operations are performed on the current track. The current track is indicated by the positioner's focus point and by patch identifiers.

If you do not see the output of the correct track, you may need to reassign the track as the primary track.

For information on patch identifiers, see [Patching Video and Audio Channels](#) on page 997.

To change the current track:

- 1 Use the **Up Arrow** or **Down Arrow** to move the focus point to the track you want to edit.

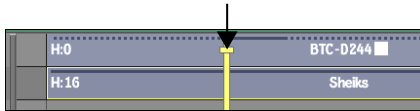

- 2 If you do not see the output of the track, click the track's channel indicator.

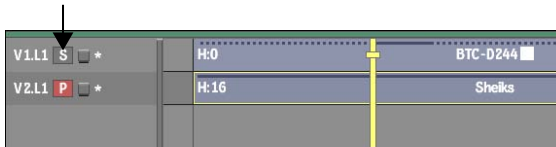

The channel indicator changes to P indicating it is the primary track, and the result clip is displayed in the viewport.



(a) Primary track channel indicator

Selecting Tracks

You can select one track at a time, multiple tracks, or all tracks. Selected tracks are yellow and their associated Selector icon appears recessed.

To select a track:

- 1 Do one of the following:
 - If the track has only one layer, click the Selector icon.
 - If the track has multiple layers, click the Collapse arrow and then click the Selector icon, or **Ctrl-click** each layer's icon.



(a) Collapse arrow (b) Selector icon for V1.L1

To select multiple tracks:

- 1 Do one of the following:
 - To select a range of tracks, **Shift**-click the Selector icon of the first and last tracks.
 - To select individual tracks, **Ctrl**-click the Selector icon of each layer.

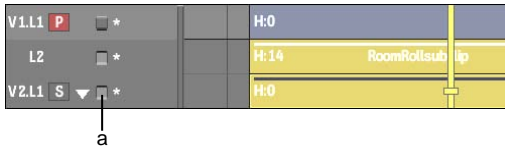

(a) Selector icon for V2.L1

To select all tracks:

- 1 Click the element selection hot spot.

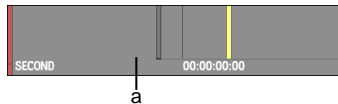

(a) Element selection hot spot

To deselect tracks:

- 1 Do any of the following:
 - **Alt**-click the element selection hot spot.
 - Click in the empty space of the timeline to the right of the slider bar.

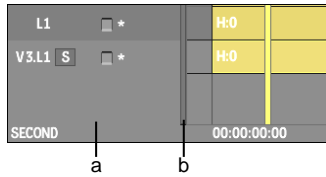

(a) Element selection hot spot (b) Slider bar

Locking Tracks

Lock tracks to prevent further editing operations from being performed on them.

To lock a track:

- 1 Click the track identifier.

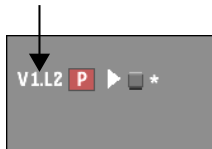

The track identifier turns black.

To unlock a track:

- 1 Click the track identifier.
The track identifier turns white.

Resizing Tracks

Resize tracks to display additional information about its elements.

To resize a track:

- 1 Drag the track identifier down to increase the height of the track or up to decrease its height.

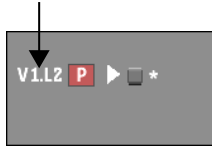

Naming Tracks

You can name any track on the timeline. Tracks are named * by default.

To name a track:

- 1 Place the focus point on the track you want to name.
- 2 Select Name Layer from the Item box, type a name in the Name field, and press **Enter**.



(a) Item box and Name field

The default track name is replaced by the one entered in the Name field.

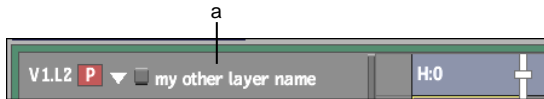

(a) Track name

NOTE If you cannot see the complete track name, drag the slider bar to the right.

Element Basics

Video segments, audio segments, and transitions all make up the elements of a timeline sequence. You can easily control how you work with any of these elements.

Selecting Elements

You can select a single element or any number of elements.

To select elements on the timeline:

- 1 Do any of the following.

To select:	Do this:
An element	Click the element.
Multiple elements	Press Ctrl while clicking each element. To add or subtract from multiple selections, hold Ctrl and select the element to be added or removed.
A range of elements on a layer or track	Click the first element, hold Shift and click the last element. All elements between the elements you clicked are selected.
A range of frames on the current track	Hold Ctrl and drag the positioner. The frames on all layers of a track that the positioner passes over are selected.
A range of frames on all tracks	Hold Shift and drag the positioner. The frames on all layers of each track that the positioner passes over are selected.
All elements	Click the element selection hot spot or press / on the numeric keypad.
Any range of frames or elements	Select an option from the Selection Method box (see step 2) and then drag to draw a rectangle or bounding box around the elements that you want to select.

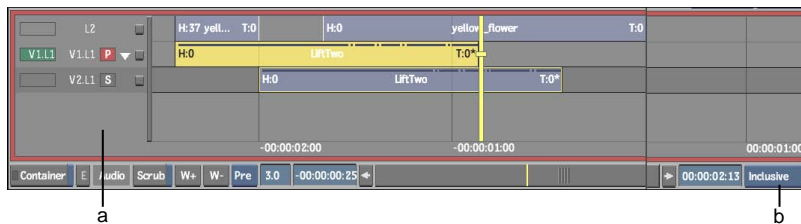

(a) Element selection hot spot (b) Selection Method box

- If you want to use the cursor to draw a rectangle or bounding box, select which elements to include in the selection from the Selection Method box.

Select:	To select:
Inclusive	All elements that are partially or entirely included in the bounding box.
Partial	Only the portions of the elements that fall within the bounding box. Audio is selected on a sub-frame basis if Sub-frame Positioner is selected in the Timeline section of the Preferences menu.
Partial A/V	Only the portions of the elements that fall within the bounding box. Audio is selected on a frame basis even if Sub-frame Positioner is selected in the Timeline section of the Preferences menu.
Bounded	Only elements that are fully in the bounding box.

NOTE More than half the height of an element must be included in the bounding box for the element to be selected. If elements are so tightly spaced that you cannot draw a bounding box without selecting an unwanted element, press **Alt+W** before drawing the rectangle.

To deselect elements on the timeline:

- Do any of the following:
 - **Alt**-click the element selection hot spot.
 - Click in the empty space of the timeline to the right of the slider bar.

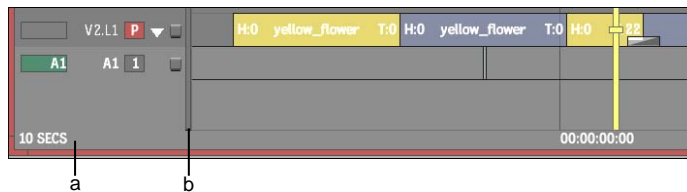

(a) Element selection hot spot (b) Slider bar

Naming Elements

You can name video elements, audio elements, and transitions.

To name an element:

- 1 Select a timeline element.
- 2 Select Name Element from the Item box, type a name in the Name field and press **Enter**.



(a) Item box and Name field

The element on the timeline is updated with the new name. Its original source name is displayed on the bottom, and its new name is displayed above the source name.

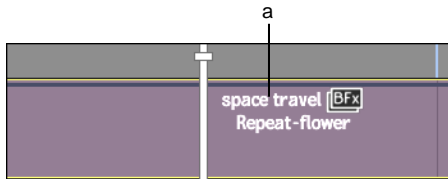

(a) Renamed element

NOTE If you do not see the name on the element, drag its track identifier down.

Adding Comments to Elements

You can add comments to the individual elements that make up a clip.

To add a comment to an element:

- 1 Select an element on the timeline.
- 2 Select Element Comment from the Item box, type a comment in the Name field and press **Enter**.

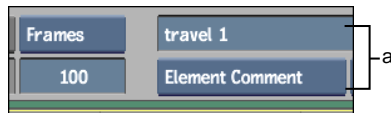

(a) Item box and Name field

The comment is added to the timeline element.



(a) Comment

Displaying Element Information

You can display information about elements on the timeline by resizing tracks or by displaying a clip information overlay.

The information displayed when resizing tracks depends on the settings in the Preferences menu (see [Clips](#) on page 849). When you display a clip information overlay of video or audio segments, the following information appears:

- The number of heads and tails associated with the element
- The source name and offsets
- The Sync Offset
- The record in/out points
- The source in/out points
- The type of soft effects applied to the element
- A BFX indicator if the segment contains any Batch FX
- The audio gain status and frame code mode on audio elements
- Element length (appears between source in and out points)

- Comments
- A clip proxy that displays the source media of the first frame used in the segment.

To display element information:

- 1 Do one of the following:
 - To increase the size of a track, drag the track identifier down or drag the vertical scroll bar towards the left.
Information about each element on a track appears.

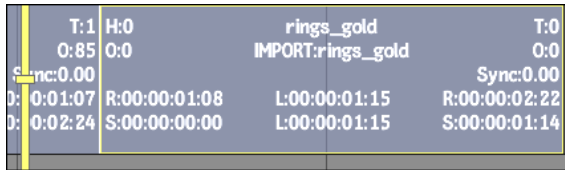

- To display a clip information overlay, **Alt**-click an element, transition, or cue mark.
An overlay of the selected element containing element information and the clip proxy appears.



Removing Elements from the Timeline

You can remove elements from the timeline without removing their track.

To remove elements from the timeline:

- 1 Select the elements, drag them to the bottom of the screen and release when the cursor changes to a green recycling icon.
The selected elements are deleted. Unselected elements remain on the track.

Searching for Timeline Elements

Although you can search for elements by scrolling the timeline and displaying information about each element, Filter Select options make it easier to find specific elements. You can also refine your search when searching specifically on segments.

To search for video elements:

- 1 Select and enable Filter from the Menu Priority box and then select Video.

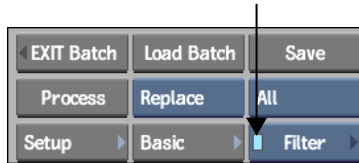

- 2 Enable any of the following filter options.

Enable:	To select:
Mark	Cue marks.
Gap	The gaps that exist between elements. You can then choose to filter only gaps, only gap effects, or both gaps and gap effects.
Cont	Container elements.
Pale grey BFX icon	Clips brought into a BFX level with the Pre option.
Black BFX icon	Clips brought into a BFX level with the Post option.
All Segs	The clip elements (regular audio or video frames).
Axis	Elements with Axis soft effects.
Wipe	Elements with Wipe soft effects.
Spark	Elements with Sparks soft effects.
CC	Elements with Colour Correction soft effects.
TW	Elements with Timewarp soft effects.
Blend	Elements with Blend soft effects.

Enable:	To select:
Resize	Elements with Resize soft effects.
Text	Elements with Text soft effects.
Cut	Cuts.
Dissolve	Dissolves.
WipeTn	Wipe transitions.
AxisTn	Axis transitions.

If you selected an option that searches segments, the following segment filter options appear.

This option:	Filters segment with:
Tape	The tape name you specify.
Source Clip	The source name you specify.
Element	The element name you specify.
Comment	The comment you specify.
From/To	The source or record timecode you specify.
MixedRes Seg	Sources not of the same resolution as the master clip.
MixedRes Hist	Sources not of the same resolution as the master clip in their history.
Soft-Import	Soft imports.
Has History	Clip history.
Unlinked	Unlinked media.
Locked	Locked soft effects.

- 3 To filter only on segment selections, enable the appropriate filter option and enter filtering information in the associated field. For the Tape, Source Clip, Element, and Comment fields, enter wildcards such as * to match any number of characters before or after the string. Enter ? to replace a specific character.

For example, to search for all clips whose names end with *rings* such as *blue_rings* and *red_rings*, you would enter **rings* in the Source Clip field. To search for all clips whose names end in a different letter such as *clipA* and *clipB*, you would enter *clip?* in the Source Clip field.

- 4 Draw a bounding box around elements on the timeline, click the element selection hot spot, or press / on the numeric keypad.

The specified elements are selected.

If you disabled Dissolve and Wipe, you can select a group of elements excluding the transitions that occur within the selection. Similarly, if you disabled Gap, you can select a group of elements excluding any gaps between them. For example, if you move a selection of elements from one track and use them to overwrite the elements in another track, the space between the incoming elements does not overwrite the material where it is placed. If Gap is enabled, the original material is overwritten with the gaps.

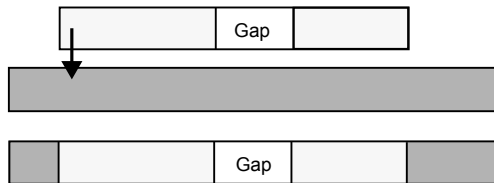

Result

If Gaps is disabled, the original material is not overwritten, as shown in the following illustration.

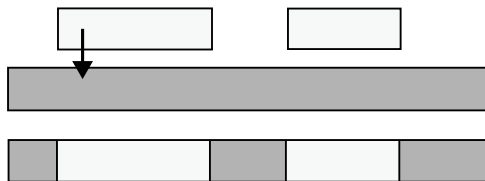

Result

To search for timeline audio elements:

- 1 Select and enable Filter from the Menu Priority box and then select Audio.



- 2 Enable any of the audio filter options that appear.
- 3 To filter only on segment selections, enter filtering information in the associated fields that appear.
- 4 Draw a bounding box around elements on the timeline, click the element selection hot spot, or press / on the numeric keypad.
The specified elements are selected.

Maintaining Sync between Elements

Create edit sync groups to preserve the relationship between video and audio elements. For example, if you have a video clip with two tracks of audio, you can create an edit sync group for all tracks. When you edit one segment that is part of an edit sync group, all segments in the group are edited in the same way.

You can also create an edit sync group to maintain the timing for multiple video elements. For example, if you have a multitrack that contains front and matte elements, you can create an edit sync group for all related elements so that the sync relationship between front and matte is maintained if you trim or slip one of the elements.

When you create an edit sync group, you define a master element and all child elements to include in the edit sync group. The master element is the reference element that defines the original sync.

When the edit sync group is enabled, any edit you perform to any element in an edit sync group affects all elements within that group. When the group is disabled, you can edit all tracks independently, regardless of the edit sync group.

Elements in an edit sync group have one of the following symbols.

Symbol	Description
m	This is the master element of the edit sync group.

Symbol	Description
=	This is a child of the master element and it is in sync.
+	This is a child of the master element and it has lost sync to the right. To regain sync, edit the element until the = sign appears, or use the Resync option.
-	This is a child of the master element and it has lost sync to the left. To regain sync, edit the element until the = sign appears, or use the Resync option.

To create an edit sync group:

- 1 Select the video or audio elements to include in the edit sync group. The first element you select is the master sync element; the others are children.

- 2 Press **Ctrl+E**.

The edit sync group is created.

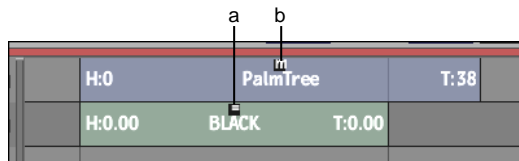

(a) Child sync element in sync with master element (b) Master sync element

To work with an edit sync group:

- 1 Enable Sync.



- 2 Select any element in the edit sync group.

All elements in the edit sync group are selected.

- 3 Edit the element.

All elements in the edit sync group are edited by the same amount.

Regaining and Resetting Sync

If an editing operation removes the sync for a track in an edit sync group, a red plus (+) or minus (-) symbol appears in the element and the Sync offset appears on the element.

You can either resync the elements or reset the offsets, creating a new sync relationship based on the current position of the segments.

To regain sync:

- 1 Select the element that is out of sync.

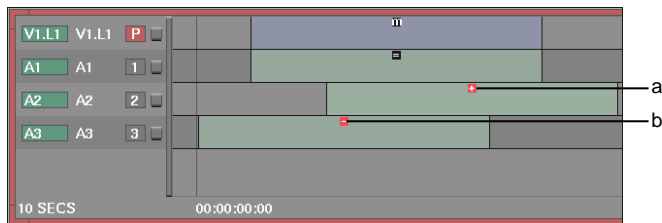

(a) Child out of sync to the right (b) Child out of sync to the left

- 2 Press **Ctrl+Shift+E**.

The element is re-synced, if possible, and the out-of-sync symbol turns to an “=” sign.

To reset sync offsets:

- 1 Select any element in the edit sync group.
- 2 Press **Shift+E**.

The segments remain in their current positions. The sync offsets are removed creating a new edit sync group.

Creating Edit Sync Groups for Multiple Video Tracks

You can include elements from multiple video tracks in an edit sync group. The following illustration shows a multitrack that includes front and matte elements for two layers and a background. Create an edit sync group for both layers so that any edit you perform to a front, for example, does not throw off the timing of the corresponding matte. By creating an edit sync group for

V1, V2, V3, and V4, you maintain the timing for the front and matte layers while working on the timeline.



If you are manually creating edit sync groups, the first element you select becomes the master sync element. If the edit sync groups were created automatically during input, the element used as the master sync element depends on the assignment of Primary and Secondary video tracks:

- If a track to be included in the edit sync group is assigned as the Primary video track, the first element on the Primary video track automatically becomes the master sync element for the edit sync group.
- If a track to be included in the edit sync group is assigned as the Secondary video track, and no other track is assigned as the Primary video track, the first element on the Secondary video track automatically becomes the master sync element.
- If no tracks to be included in the edit sync group are assigned as either Primary or Secondary video tracks, the first element on the highest video track in the stack becomes the master sync element.

To create an edit sync group with multiple video tracks:

- 1 Select the element you want to use as the master sync element.
- 2 Hold down **Ctrl** and click the other video elements that you want to include in the sync group.
- 3 Press **Ctrl+E**.
The sync group is created.

Using Edit Sync for Insert and Overwrite Edits

Edit sync groups can also maintain video and audio sync while you perform insert and overwrite edits. When the Sync button is enabled, you can perform any insert or overwrite edit without removing the sync for the video and audio

tracks. When the Sync button is disabled, insert and overwrite edits remove the sync for video and audio tracks.

The following example illustrates what happens when you insert a video clip onto the timeline with Sync disabled.

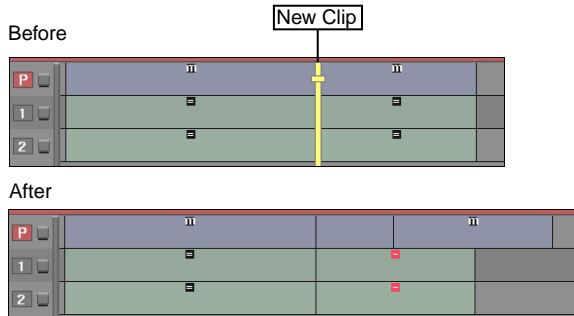

The following example shows what happens when you insert a video clip onto the timeline with Sync enabled.

NOTE A cut is placed on A1 and A2 to maintain sync.

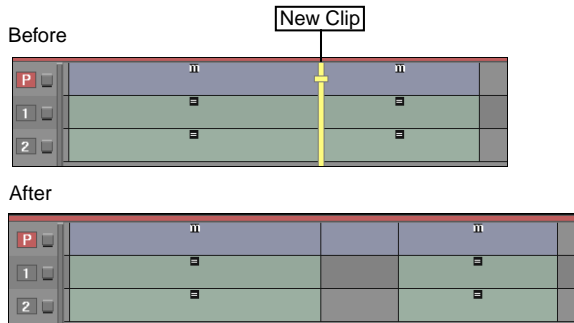

Deleting and Disabling Edit Sync Groups

When you delete an edit sync group, the sync is removed from all elements that were part of the edit sync group. You can also temporarily disable an edit sync group.

To delete an edit sync group:

- 1 Select one of the elements that make up the edit sync group.
All edit sync group elements are selected.

- 2 Press **E+spacebar**.

To temporarily remove edit sync:

- 1 Disable Sync.
- 2 Select an element in the edit sync group.
No other elements in the edit sync group are selected.
- 3 Edit the selected element.
No other elements in the edit sync group are affected. A red plus (+) or minus (-) symbol appears on every element that is out of sync with the master sync element.

Patching Video and Audio Channels

When you set record and source clips, you have to decide what source clip channels you want to use, and to which tracks you want to record them. To connect the source channels to the timeline tracks, you use patching. You can use the patch identifiers on the timeline or you can use the patch panel.

For instance, assume you have a source clip with one video channel and two audio channels. You want to record it to a timeline that has two video tracks and eight audio tracks. Use patching to point the source channels to the destination timeline tracks. Perhaps you usually insert video on track V1 and audio on tracks A1 and A2, but now you want to switch destination tracks to V2, A3, and A4. Patching allows you to do this.



Source patched to V1, A1, and A2.



Source patched to V2, A3, and A4.

When you use the patch identifiers, patching information is kept with the record clip. If you patch a source clip, then add a new layer to the timeline, the source clip follows the track to which it was originally patched. This allows for a natural workflow of setting up the patch for a source clip, adding a new layer, then setting up the patching for another source clip. For a protocol in which the source does not move with its destination track, use the patch panel instead.

Patching on the Timeline

Use the patch identifiers on the timeline to quickly and easily connect source channels to record tracks. When you select a source clip, patch identifiers indicate what channels you can record from the source to the timeline.

In the following example, a clip has one video track and two audio tracks. When you select the clip, green patch identifiers appear next to the V1.L1, A1, and A2 tracks on the timeline. If you record the selected clip to the timeline, it is edited to the indicated tracks.



(a) Patch identifiers (b) Track identifiers

You can adjust the patching to record the source audio channels to A3 and A4. You would then see the following patch identifiers. Empty grey patch identifiers next to a track indicate that nothing is patched to that track.



(a) Unpatched track

In the next example, the selected source clip has one video track (patched to V1.L1) and four audio tracks (patched to A1, A2, A3, and A4).



NOTE If the source clips have more tracks than the record clip, add video/audio tracks to the timeline to see the patching of the “hidden” source tracks.

If you disable source channels the disabled tracks appear in the patch identifiers as dark grey boxes. They show that the source contains channels, but these channels are not recorded to the timeline. Similarly, you can disable a track on the timeline so that a record operation does not affect the track.

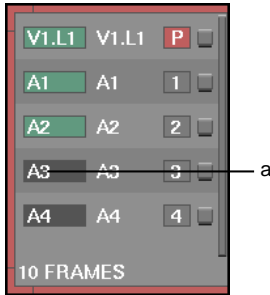

(a) Disabled source channel/disabled track

To patch a source channel to a record track:

- 1 Select a source in the schematic.

Source track patch identifiers appear in the timeline for each channel in the source.



(a) Source track patch identifiers

- 2 Create the patch:

- Drag left on the source track patch identifier to decrease the source track number, or drag right to increase it.
- Click a patch identifier to lock the patch; that is, to prevent the patch from occurring when you record the clip to the timeline.

- 3 Drag right on grey patch identifiers to record channels to unpatched tracks.

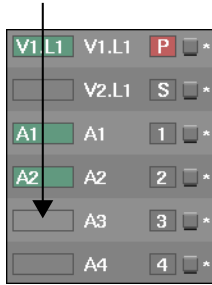

To disable a track:

- 1 Click the patch identifier.

The patch identifier turns black indicating you cannot record to it.

TIP Click again to enable the track.

Using the Patch Panel

Use the patch panel to “lock” video and audio signals between the source and record clips. Normally, when a source clip is used in an editing operation, the Primary video track in the source clip is applied to the Primary video track in the record clip; the first audio track in the source clip is applied to the first audio track in the record clip, and so on. You can change this default mapping in the patch panel.

The maximum number of audio tracks that you can patch simultaneously depends on your system configuration.

Each field in the patch panel shows the Source track and the Record track.

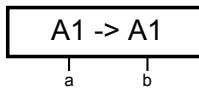

(a) Source output channel (b) Record output channel

Patch panel fields are colour coded according to the availability of tracks on the record clip.

Colour:	Indicates:
Light grey	The track does not exist.

Colour:	Indicates:
Dark grey	The track exists but is locked.
Blue	The track is unlocked.

To display the patch panel:

- 1 Select and enable Patch from the Menu Priority box.

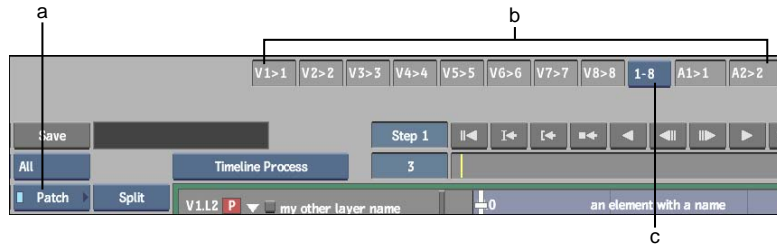

(a) Menu Priority box (b) Patch panel (c) Audio Track Selection box

To use the patch panel:

- 1 Display the patch panel.
- 2 Make sure the appropriate record tracks exist and are unlocked. For example, if you want to reassign source track A4 to record track A8, make sure the record clip has an A8 track, and it is unlocked.
- 3 Use the Audio Track Selection box to switch between the following groups of audio tracks:
 - 1-8
 - 9-16
 - 17-24
 - 25-32
- 4 Click the field that contains the track you want to change, and set the new path. Note that the corresponding field updates automatically.

NOTE Always modify the destination and not the source. For example, if you want to reassign A3->A4, click in the box that has A4 as the record and then drag until A3 is the source.

The following figure illustrates patching source track A3 to record track A4.

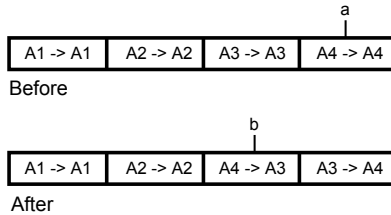

(a) Enter the new track in this field (b) Corresponding field updates

- 5 Insert or overwrite the source clip onto the record clip.

When you perform the edit, the video and audio signals are routed using the assignments in the patch panel.

NOTE Patch panel settings are global and not based on individual clips. When you reassign tracks using the patch panel, the new settings apply to all edits until the patch panel is reset. You can reset to the default assignments by clicking the Reset button. Keep in mind that resetting the patch panel does not affect clips with track assignments that have already been modified.

Setting In Points and Out Points

Use in points and out points to determine where and how edits are inserted on the record clip. In and out points also determine what part of a source clip is used when inserting or overwriting material.

For example, assume you have a 200-frame source clip, but are only interested in frames 50-125. By using these frames as your in points and out points, only the frames that lie between them are visible after making the edit. The remaining frames are still available as head and tail frames, which you can use to trim the edit or create a dissolve.

NOTE In and out points are used only in timeline editing.

In points and out points appear both on the timebar and on the timeline. An in point appears as a white left square bracket and an out point appears as a white right square bracket.

The timeline positioner acts as an implicit in point when performing overwrite and insert edits. If there is no in or out point in the record clip, the positioner

in the record clip is used as an implicit in point. The new material from the source clip is inserted at the frame where the positioner is located.

If there is no in point or out point in the source clip, the positioner in the source clip is used as an implicit in point. If there is an in point and/or an out point in the source clip, the positioner is ignored.

Marking In and Out Points

You mark in and out points directly in the timeline or on the clip itself using the frame marking controls found in the Player Setup menu and the Batch Basic menu.

In the frame marking controls, the timecode for the in and out points appears in the fields next to the In and Out buttons. The duration between the in and out points appears in the Duration field.

On the timeline, the material between the in and out points is highlighted.

To mark in points and out points on the timeline:

- 1 Display the frame where you want to insert the in or out point.
- 2 Do any of the following:
 - To mark an in point, press [
 - To mark an out point, press]

In points and out points appear on the timebar and on the timeline.

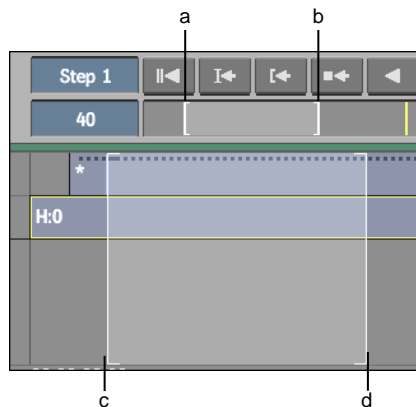

(a) In point in timebar (b) Out point in timebar (c) In point in timeline (d) Out point in timeline

TIP You can also add in points and out points while the clip is playing.

To mark in and out points based on the current timeline selection:

- 1 Make a selection on the timeline.
- 2 Press '!'.
The incoming frame of the selection is marked with an in point and the outgoing frame is marked with an out point.

To mark in points and out points using the frame marking controls:

- 1 Do one of the following:
 - In Batch, click Basic.
 - In the Player, click Clip & Setup.
- 2 Display the frame where you want to mark the in point.

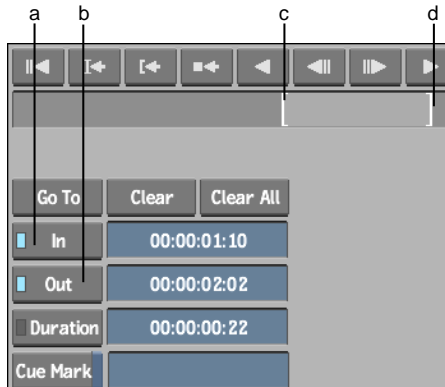

(a) In point button (b) Out point button (c) In point in timebar (d) Out point in timebar

- 3 Click In.
An in point is added at the current frame. The blue LED indicates that the field is constrained; the in point will not change regardless of any changes made to the out point or duration.
- 4 Display the frame where you want to mark the out point.
- 5 Click Out.

An out point is added at the current frame. The blue LED indicates that the field is constrained. You cannot change the duration now that both the in point and out point are constrained.

To toggle the constraint for any field on or off:

- 1 **Ctrl-click** the label.

NOTE The In and Out buttons can be constrained. When two of the three buttons are constrained, the unconstrained one cannot be modified. Constraining in points and out points is useful when creating timewarps.

To edit in and out points:

- 1 Do one of the following:
 - In the frame marking controls, drag the cursor in the In and Out fields to the right of the In and Out buttons.
 - In the frame marking controls, click the In, Out, or Duration field to open the numeric keypad and then enter a timecode.
 - On the timeline, move the positioner to a new location and then press [to move the in point or] to move the out point. The original in or out point is replaced by the one at the new location.

Deleting In Points and Out Points

You can delete in and out points individually or all at the same time.

To delete in or out points:

- 1 Do one of the following:
 - In the frame marking controls, click Clear and then click the In or Out button.
 - On the timeline, press **spacebar+[** to delete the in point or **spacebar+]** to delete the out point.

The in point or out point is deleted.

To delete in and out points:

- 1 Do one of the following:
 - In the frame marking controls, click Clear All and then click the In, Out, or Duration button.
 - On the timeline, press **spacebar**+ [+].
The in points and out points are deleted.

Marking Frames of Interest

Use cue marks to mark frames of interest on a clip. You can then quickly go to the marked frames. Cue marks are for reference purposes only; they do not affect the clip and are not used in any editing operations.

On the timeline, you can add a mark to all tracks (*cue mark*), or you can add a cue mark to a single track or layer (*segment mark*). Segment marks move on the timeline as you trim, slip, or slide a clip whereas cue marks stay at the same position on the timeline.

You can also add cue marks and cue mark comments using the frame marking controls in the Basic menu in Batch and the Setup menu in the Player. The following example shows the frame marking controls in the Batch Basic menu.

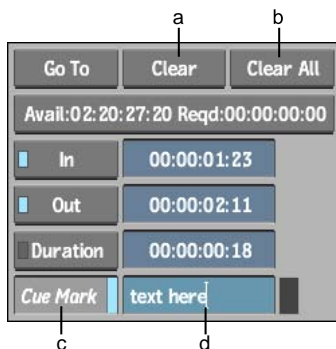

(a) Clear button (b) Clear All button (c) Cue Mark button (d) Comment field

To insert marks:

- 1 Go to the frame where you want to insert the cue mark.

- 2 Add a mark by doing one of the following:
 - Enable Cue Mark in the Player Setup menu or the Batch Basic menu to insert a cue mark on the clip.
 - Press **** to insert a cue mark on the entire timeline.
 - Press **Shift+** to insert a segment mark on the current track or layer.

Cue marks set on the entire timeline appear on the timebar and on the timeline. Segment marks set on a track or layer appear only on the timeline.



(a) Cue mark on entire timeline (b) Segment mark on V1.L2

NOTE You can add marks while the clip is playing.

To move between marks:

- 1 Do any of the following:
 - Press **Ctrl+** to move to the next cue mark on the clip.
 - Press **Alt+** to move to the previous cue mark on the clip.
 - Press **Ctrl+Shift+** to move to the next segment mark on the current track or layer.
 - Press **Alt+Shift+** to move to the previous segment mark on the current track or layer.

NOTE You can also use playback controls to move between marks.

To delete one cue mark:

- 1 Go to the marked frame.

- 2 Do any of the following:
 - In the timeline, press **spacebar+\<** to delete a cue mark from the entire timeline.
 - In the timeline, press **Shift+spacebar+\<** to delete a track mark from the current track.
 - In the Player Setup menu or the Batch Basic menu, disable Cue Mark to delete a cue mark from the clip.

NOTE You can also gesturally remove cue marks by dragging them to the bottom of the screen.

To delete all cue marks:

- 1 Do any of the following:
 - In the Player Setup menu or the Batch Basic menu, click Clear All and then disable Cue Mark.
 - In the timeline or the Batch Basic menu, press **Ctrl+spacebar+\<**. All cue marks and track marks are deleted.

Lifting Cue and Segment Marks

You can lift segment and cue marks with a clip. To lift cue marks, either select them or have an in or out point in the record clip before you perform the lift operation.

To lift marks:

- 1 Do one of the following:
 - To lift only segment marks, select the element you want to lift and press the Lift hot key (>).
 - To lift cue marks and segment marks, select the cue marks, select the element you want to lift, and then press the Lift hot key (>). Alternatively, set in and out points on the record clip.

Adding Comments to Cue and Segment Marks

You can add comments to cue marks and segment marks to provide yourself or another editor with notes about the clip. For example, add a comment about a shot that you want to insert at a particular frame.

To add comments to marks:

- 1 Go to the mark.
- 2 In the Player Setup menu or the Batch Basic menu, type a note in the Comments field and press **Enter**.



To view comments on marks:

- 1 Hold **Alt** and click the mark.

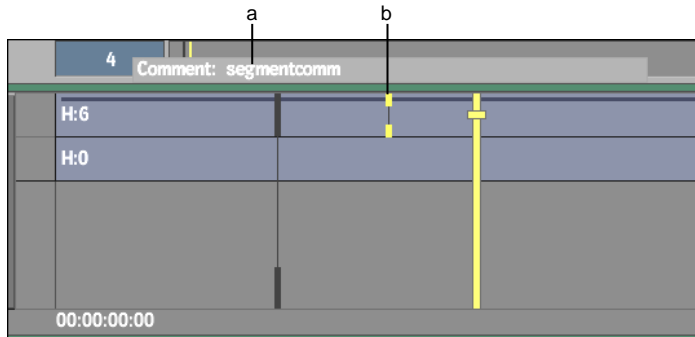

(a) Comment for selected segment mark (b) Segment mark

To remove comments from marks:

- 1 Go to the mark.
- 2 Erase the text in the Comments field in the Player Setup menu or the Batch Basic menu and press **enter**.

Creating a Cut

When you splice clips together, the location at which one clip changes to another is called a cut. A cut is useful when you want to extract part of an element or end a shot at a given frame.

You can make a cut at any point on a segment. A cut creates a transition with a head equivalent to the duration of the segment before the cut and a tail equivalent to the duration after the cut. For example, if you make a cut after the 5th frame in a 10-frame clip, the cut has a tail of 5 frames and a head of 5 frames.

In a match frame cut, the outgoing and incoming shots are from the same source and the outgoing and incoming frames are consecutive. Match frame cuts are indicated by an “=” on the cut point.

Image courtesy of Quietman

To add a cut on the timeline:

- 1 Move the positioner over the frame where you want to add a cut.
- 2 Make sure the focus point is over the appropriate track.
- 3 Press **Delete**.

A match frame cut is added at the specified location.

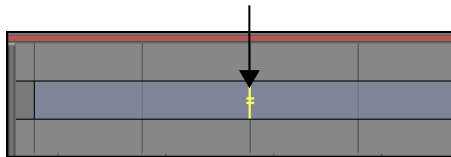

- 4 To add a cut to all tracks at the same frame, press **Shift+Delete**.

To remove a match frame cut:

- 1 Select the element on both sides of the match frame edit or select the cut.
- 2 Press **Ctrl+Delete**.
The cut is removed and the two elements are joined together.

Swapping Batch Timeline Elements

You can quickly swap elements on the Batch timeline. If segments contain timeline effects, they are swapped as well.

You can swap the following elements:

- Video segments
- Audio segments
- Contiguous sequences of elements
- Video transitions (unless they start or end a contiguous sequence of elements)
- Audio transitions

Elements must be compatible to be swapped. Compatible elements are:

- Video segments
- Audio segments
- Video transitions
- Audio transitions

The following elements cannot be swapped:

- Gaps (unless they are between elements in a contiguous sequence)
- Cuts
- Cue marks
- Individual soft effects

To swap Batch timeline elements:

- 1 Select two elements belonging to the same family.

A contiguous sequence of elements is treated as a single element as long as the transition between the elements is selected. A gap can be part of a contiguous element as long as it is not at the beginning or end of the sequence.

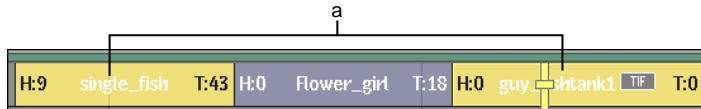

(a) Segments selected to be swapped

2 Press S.

The elements are swapped according to the ripple setting. If the segments contain any soft effects, they are swapped as well.

If Ripple is disabled, the segments are timewarped using a Constant Fit-to-Fill timewarp to fill each other's location. If there is already a timewarp on the segment, the timewarp is replaced by the Constant Fit-to-Fill timewarp. Contiguous sequences ripple regardless of Ripple status because they cannot be timewarped.

Transitions keep their alignment but their duration changes based on the head and tail frames of the destination segments.

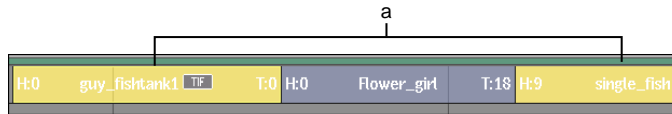

(a) Selected segments swapped according to Ripple setting

Matching Elements with Their Source Clip

You can match an element with its source clip. If a match is found, a copy of the clip is put in the Batch schematic.

In the Preferences menu, the Match option in the Timeline section determines where Flame looks for the source clip.

If the segment you are matching has head and tail frames, these frames are included in the copy that is created in the schematic. An in point and an out point are added to the copy, marking the portion of the clip that is used in the original segment. This allows you to overwrite the original segment with the matched segment such that the overwrite conforms exactly with the original. For example, you could apply an effect to the matched clip, process it, and overwrite the original.

If you are working with Batch setups, you can also match source clips used in any BFX level. See [Matching and Copying Sources from BFX View](#) on page 1413.

NOTE Flame has one level of Match. If you process a source clip, the new clip becomes the source clip, which can be found with the Match command. It is therefore a good idea to always keep a copy of the un-edited original material.

To match a clip with its source clip:

- 1 Select the elements that you want to match in the timeline.

TIP If you do not make a selection, the clip under the positioner's focus point is matched.

- 2 Do one of the following:
 - Press **Shift+M** to create a matching source clip with trimmed head and tail. The matching source clip appears in the schematic, including all handles. If your selection included transitions, the source clips and handles are included in the match results.
 - Press **Ctrl+M** to create a matching source clip with in and out points that mark the section of the source used in the timeline. The matching source clip appears in the schematic, without handles. If your selection included transitions, only those frames that are used by the transition are included in the match results.

Editing to the Batch Timeline

4 |

Topics in this chapter:

- [About Editing to the Timeline](#) on page 1015
- [Batch Timeline Workflow](#) on page 1016
- [Setting Record and Source Clips](#) on page 1019
- [Placing Shots Gesturally on the Timeline](#) on page 1021
- [Previewing the Placement of Shots on the Timeline](#) on page 1024
- [Inserting Clips into an Edit Sequence](#) on page 1025
- [Overwriting Clips in an Edit Sequence](#) on page 1027
- [Replacing Shots](#) on page 1028
- [Performing a Three-Point Edit](#) on page 1030
- [Performing a Four-Point Edit](#) on page 1031
- [Removing Elements from an Edit Sequence](#) on page 1032

About Editing to the Timeline

Editing clips to the Batch timeline allows you to stack video for vertical editing and apply effects to selected segments while continuing to work in a procedural environment. You can also create audio mixes where similar types of audio are grouped together by track. You can conform to an offline version as well as load

clips to and from other Visual Effects and Finishing products with all edits and effects preserved.

Each clip brought into Batch has an associated timeline. There are several ways to edit clips to the timeline. You can build a sequence by adding clips in the schematic to another clip's timeline. You can perform insert edits where the timeline changes length to accommodate new material. You can also overwrite existing material with new material such that the timeline duration does not change. You can edit entire clips as well as specific frames to any location on the timeline.

When you add other clips to a clip's timeline to create an edit sequence, the clip that you first selected is the “owner” of the timeline. When you make changes to a clip in the timeline, [E] appears after its name in the Batch schematic and the clip name is displayed in blue, indicating it is edited. This is the clip you select to again access the edit sequence.

You can edit clips to the timeline gesturally or using hot keys. When you use hot keys, the Ripple mode is implicit in the editing function. For example, the timeline will always ripple with the insert hot key (I) and will never ripple with the override hot key (O) regardless of the Ripple mode.

When you edit gesturally, note the following:

- The Ripple mode determines whether gestural edits are performed as inserts (Ripple button is enabled) or as overwrites (Ripple button is disabled).
- Edits that involve using in and out points such as three-point and four-point edits cannot be done with gestural editing.
- Patch panel settings are not observed when dragging to the timeline.
- You must use Snap options to align gestural edits on the timeline.

Batch Timeline Workflow

It is recommended that you edit clips in the timeline prior to creating Batch FX. If you perform operations such as trimming a clip or adding a timewarp after completing an effect, you risk affecting the timing of the effect or trimming out frames that were intended to be part of an effect. Also, by getting the edit as close to final as possible before doing effects, you avoid spending too much time rendering.

The following are suggested workflows for using the Batch timeline. Regardless of which workflow you use, you have the option of saving modified clips to

the desktop or to the _Edited library. See [Managing Edited Clips in Batch](#) on page 1188.

Starting with an Assembled Clip

This workflow describes how to apply an effect to a single segment within an existing sequence, such as an assembled clip.

Step:	Refer to:
1. Load and assemble material from EDL, AAF or XML files.	Importing AAF Files on page 481, Importing EDL Files on page 321, and Importing Final Cut Pro XML on page 431.
2. Bring the assembled clip into Batch.	Adding Clips to the Schematic on page 1285.
3. Tweak the edits in the timeline to conform the assembled clip to an offline version. For example, trim segments or adjust dissolves.	Editing Essentials on page 927, Trimming Shots on page 1045, and Creating Dissolves on the Timeline on page 1078.
4. Add Batch FX to the segments.	Soft Effects on page 1111 and Batch Processing on page 1283.
5. Process or commit the Batch timeline.	Managing Timeline Media on page 1179.

Timewarping Clips to Change the Timing

If you are working with clips in Batch that have multiple frame rates (for example, both NTSC and PAL clips), you can use the timeline to timewarp the video and audio to change the frame rate of the clips so that they match each other. See [Converting a Clip to a Standard Frame Rate](#) on page 1164.

Editing a Single Clip

You can perform edits on a single clip in the timeline prior to using the clip in a Batch process tree.

Step:	Refer to:
1. Load the clip into Batch.	Adding Clips to the Schematic on page 1285.
2. Access the timeline of the clip.	Accessing the Timeline on page 970.
3. Apply edits such as trimming or creating a timewarp.	Trimming Shots on page 1045 and Creating and Modifying Timewarps in the Timelines on page 1160.
4. Use the clip in a Batch process tree.	Batch Processing on page 1283.
5. Process the result with the Output node.	Outputting and Exporting Batch Results on page 1322.

Large Scale Project

If you are starting with several shots that require effects and the shots have not been pre-assembled, you may want to use the timeline to assemble a sequence of the shots once all the effects have been added and the shots have been processed. You can then add transitions between shots, sync the audio, and adjust the timing.

Step:	Refer to:
1. Create several Batch trees for single shot effects and apply effects. Do not use the timeline at this point except for trimming or syncing the audio.	Batch Processing on page 1283 and Maintaining Sync between Elements on page 992.
2. Process all the single shots.	Outputting and Exporting Batch Results on page 1322.
3. Bring the processed shots into a new Batch setup.	Adding Clips to the Schematic on page 1285.
4. Assemble all the shots into one timeline.	This chapter.

Step:	Refer to:
5. Apply dissolves, cuts, trims and other editing operations to complete the sequence.	Creating Dissolves on the Timeline on page 1078 and Trimming Shots on page 1045.
6. Apply global level effects such as degrain, regrain, or colour correction.	Batch Processing on page 1283.
7. Process the clip with the Output node.	Outputting and Exporting Batch Results on page 1322.

Setting Record and Source Clips

When editing material from one clip to another using keyboard commands, you first need to specify which clip will contain the resulting edit (the record clip) and which clip will provide the source material for the edit (the source clip). You can only specify one record clip and one source clip at any one time, and you must set the record clip before the source clip.

When editing part of a source clip into a record clip, the current time position of the source clip serves as an implicit in point. To help keep track of your edits, you can display both the source clip and the record clip in the viewports as you work.

When a record clip is selected, the Batch timeline positioner is red. When a source clip is selected, the Batch positioner is green. Otherwise, it is yellow.

To set the record clip:

- 1 Select a clip in the schematic and display its timeline.
- 2 **Ctrl**-click the Source TL button.

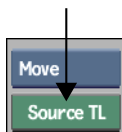

A red bar appears on the clip proxy in the schematic indicating it is the record clip. The Source TL button changes to Record TL indicating that the clip currently displayed in the timeline is the record clip. The timeline appears with a red border, and the Batch timeline positioner turns red.



(a) Batch timeline positioner (b) Record timeline border (c) Record TL button

To set the source clip:

- 1 Set the record clip.
- 2 Select a clip in the schematic.

The Record TL button changes to Source TL, indicating that the clip currently displayed in the timeline is the source clip. The timeline appears with a green border, and the Batch timeline positioner turns green.

A green bar appears on the clip proxy indicating it is the source clip.

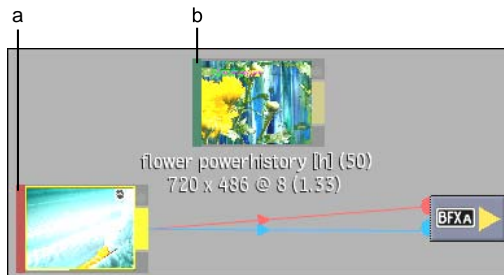

(a) Record clip (b) Source clip

To display the record and source clips in the viewports:

- 1 Change to 2-up view (press **Alt+2**).

NOTE These views are only available after you have set the record and source clips.

- 2 From one viewport, select Source Clip from the View box (or press **F7**).
- 3 From the other viewport, select Record Clip from the View box (or press **F8**).

To change the source clip:

- 1 Select another clip in the schematic.

To navigate between the source and record clip timelines:

- 1 Click the Record/Source TL button or select the clip in the schematic.

To change a record clip back to a source clip:

- 1 **Ctrl**-click the Record TL button.

The red and green borders are removed from the clip proxies, and the timelines of both clips appear with green borders indicating they are source clips.

Placing Shots Gesturally on the Timeline

When you drag a source clip to the timeline or move a segment to another location on the timeline, the shot is placed on the track directly beneath the cursor. If you drag a shot below the last track on the timeline, a new track is created. You can drag entire source clips as well as specific frames to any location on the timeline.

You control where your shot will be placed on the timeline using Snap options and whether your edit sequence changes duration by setting the Ripple mode.

Setting the Ripple Mode

When you gesturally insert new material into a timeline or overwrite existing material with new material, you determine what happens to your edit sequence with the Ripple mode.

When Ripple is on, the overall length of the edit sequence is affected when you add a clip to the edit sequence. The duration increases (“ripples”) to accommodate the added material.

When Ripple is off, the overall length is not affected when you add a clip to the edit sequence. The timecode and frame count are unaffected. Depending on the type of edit, the new clip either overwrites the underlying clip, or the new clip is timewarped (expands or contracts) to fill the same number of frames as the clip it is replacing.

The Ripple mode also affects what happens when you remove material from the edit sequence. When Ripple is on, the edit sequence collapses to fill the gap left by the removed clip. When Ripple is off, removing a clip leaves a gap.

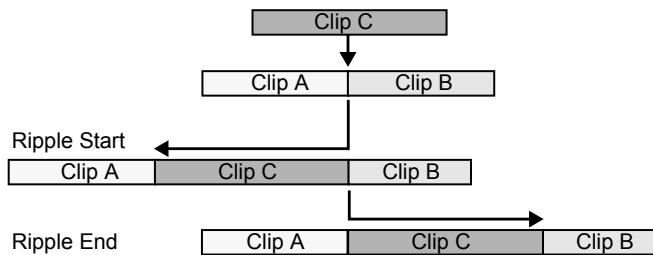

To enable Ripple mode:

- 1 Select Editing from the Menu Priority box and then enable Ripple.
- 2 Select an option from the Ripple Direction box.

Select:	To:
Start	Ripple all clips preceding the selected clip or transition. The clips following the selected clip or transition are unaffected.
End	Ripple all clips after the selected clip or transition. The clips preceding the selected clip or transition are unaffected.

NOTE You only need to enable Ripple mode when editing gesturally. If you edit using hot keys, the hot key determines whether your edit ripples (regardless of the status of the Ripple button).

Setting Snap Options

To properly align gestural edits on the timeline, you must select a Snap option.

To set up the alignment of shots on the timeline:

- 1 Select one of the following Snap options (or press **Alt+M** to cycle through the Snap options).



Select:	To snap:
Snap Closest	To the closest of the following: transition, positioner, in point, out point. The cursor must be within a given range of these elements on the timeline for this option to work.
Snap Marks	To the closest in or out point.
Snap Positioner	To the positioner.
Snap Transition	To the closest transition.

NOTE To drop the clip at the current location on the timeline, select Snap Off.

Dragging Shots to the Timeline

You can edit entire shots to the timeline as well as specific frames of a shot by setting in and out points on the source clip.

To drag a shot from the Batch schematic to the timeline:

- 1 Set a Ripple mode.
- 2 Select a Snap option.
- 3 Display the timeline into which you want to place the source clip.
- 4 Do one of the following:
 - To copy the source clip, press **Alt+Shift** and drag the copy of the source clip to the timeline.
 - To move the source clip, press **Ctrl+Shift** and drag the source clip to the timeline.
- 5 Release the cursor when it is over the appropriate location on the timeline. The source clip snaps to the specified location.

To drag specific frames of a shot from the schematic to the timeline:

- 1 Create a subclip by setting in and out points around the material in your source clip that you want to place on the timeline.
- 2 Display the subclip's timeline and then press **Ctrl+'** to select the material between in and out points.
- 3 Set a Ripple mode.
- 4 Select a Snap option.
- 5 Display the timeline into which you want to place the subclip.
- 6 Do one of the following:
 - To copy the subclip, press **Alt+Shift** and drag the copy from the schematic.
 - To move the subclip, press **Ctrl+Shift** and drag the subclip from the schematic.
- 7 Release the cursor when it is over the appropriate location on the timeline. The source clip snaps to the specified location. The material beyond the in and out points is also moved but as head and tail frames. These frames can be retrieved by trimming.

Previewing the Placement of Shots on the Timeline

When you drag a segment to another location on an existing track, you can preview where it will be placed by displaying a phantom segment. The phantom segment appears in all Snap modes including when Snap is off.

To preview the placement of shots:

- 1 In the Timeline section of the Preferences menu, enable Phantom Inserts in the Display group.
- 2 Select a segment on the timeline and drag until the cursor is close to where you want to make an insertion. The location of the cursor on the timeline determines whether your shot's head or tail snaps to the element. The segment turns pink as a preview of where it will go after you release the cursor.



(a) Tail of shot will snap to segment

- 3 Release the cursor when you are satisfied with the location of the phantom segment.

The timeline is updated with the new material.

Inserting Clips into an Edit Sequence

When you insert material between existing material in a record clip, the overall length of the record clip may be modified. The result of the insert depends on how you perform the edit. In the following illustration, New Clip is inserted gesturally at the transition between Clip A and Clip B. Everything after the transition is moved ahead in order to make room for New Clip.

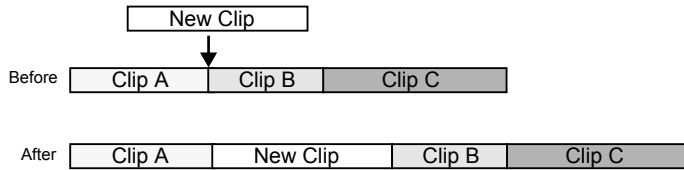

You can insert a source clip anywhere in a record clip—append it to the end of a clip or insert it at any frame of an element.

The following illustration demonstrates the result of inserting New Clip at a frame in the middle of Clip B. Every frame after the edit point is moved ahead to accommodate New Clip.

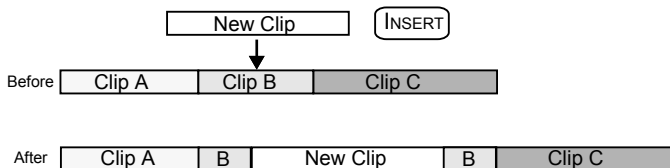

To insert a clip at a transition gesturally from the schematic:

- 1 Display the timeline for the edit sequence in which you want to insert a clip.
- 2 Enable Ripple and set the ripple direction.
- 3 Select a Snap option.
- 4 Press **Ctrl+Shift** and drag a source clip to the timeline.

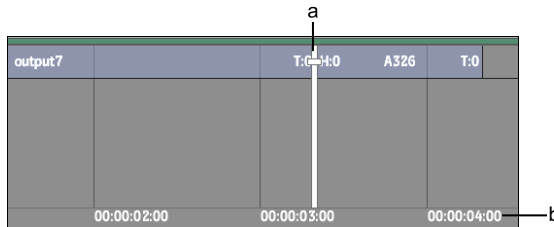

(a) Insert is set to snap to positioner (b) Duration of sequence before the insert

- 5 Drop the source clip at the transition where you want to insert it.

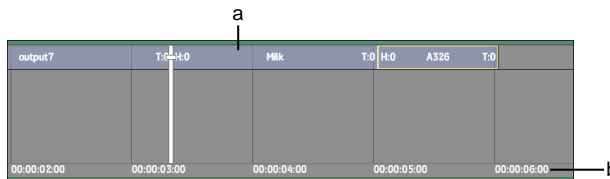

(a) Inserted source clip (b) Duration of sequence after the insert

To insert a clip in the schematic at a frame between transitions using the hot key:

- 1 Set the clip where you want to insert a clip as the record clip.
- 2 Set the clip that you want to insert as the source clip.

NOTE To insert the source clip starting at a specific frame, move the source timeline positioner to the frame that you want to use as the beginning of the insert.

- 3 Go to the frame in the record timeline where you want to insert the source clip.

- 4 Press **I**.

To insert a clip at the end of an edit sequence:

- 1 Set the record and source clips.

- 2 Press **A**.

The source clip is appended to the record clip.

Overwriting Clips in an Edit Sequence

When you overwrite existing material in the record clip with new material, the overall length of the record clip does not change. The result of the overwrite edit depends on how you perform the edit. In the following illustration, New Clip is edited gesturally at the transition between Clip A and Clip B. Clip B is overwritten. Clip A and Clip C are unaffected.

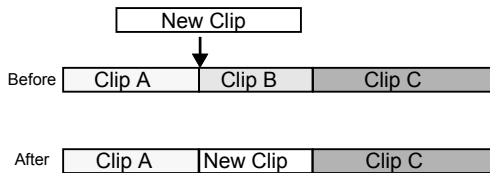

You can also edit a source clip into the record clip at any frame. The source will overwrite all existing material for its duration. In the following illustration, New Clip is edited into the record clip at a frame in Clip A. Frames after the insertion point are overwritten by New Clip. All of Clip B and some of Clip C are overwritten.

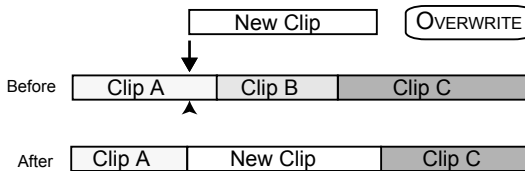

When you overwrite a section of the timeline with a source clip that contains gaps, there are two options:

- Press **O** to fill gaps in the source clip with the media already on the timeline.
- Press **Shift+O** to preserve the gaps in the source clip as gaps.

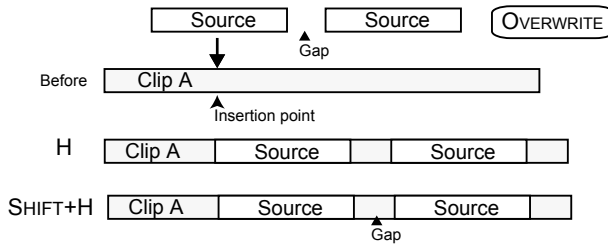

To overwrite a clip at a transition gesturally in the schematic:

- 1 Display the timeline for the edit sequence where you want to overwrite a clip.
- 2 Disable Ripple.
- 3 Select a Snap option.
- 4 Press **Ctrl+Shift** and drag the source clip to the timeline.
- 5 Drop the source clip where you want to make the overwrite.
The edit sequence does not change duration to accommodate the new clip.

To overwrite a clip at a frame between transitions using the hot key:

- 1 Set the clip where you want to make an overwrite as the record clip.
- 2 Set the clip that you want to use as the overwrite as the source clip.

NOTE To overwrite with material that starts at a specific frame, move the source timeline positioner to the frame that you want to use as the beginning of the overwrite.

- 3 Go to the frame in the record timeline where you want to make the overwrite.
- 4 Press **O**.

Replacing Shots

When you replace shots on the timeline, you decide whether the edit sequence changes duration if the shot being replaced is of a different duration than the shot replacing it.

You replace shots using hot keys.

Ripple Replace Edits

A ripple replace is an insert edit in which an element that lies between two transitions is “swapped” for the incoming source clip. As the name implies, ripple replace edits ripple, meaning the edit sequence changes duration if the source clip is of a different length than the element it replaces.

In the following illustration, New Clip replaces Clip B. As New Clip is longer than Clip B, everything after Clip B is moved ahead to accommodate the duration of New Clip.

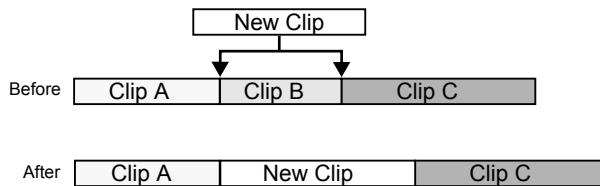

To ripple replace in the schematic:

- 1 Set the record and source clips.
- 2 In the record timeline, select the element you want to ripple replace, or place the positioner over the element.
- 3 Press **Shift+R**.

Replace Edits

Replace is an overwrite edit where the edit sequence does not ripple. If the source clip is a different length than the element it replaces, the source clip is shortened or lengthened proportionally to fit the duration of the replaced element. This creates a timewarp effect with a mix value of 0.

In the following illustration, New Clip replaces Clip B. Although New Clip is longer than Clip B, the overwrite operation does not change the duration of the record clip. Only the exact number of frames in New Clip that are needed to fill Clip B are used.

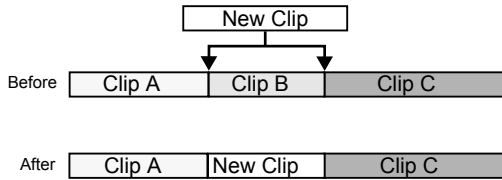

To replace in the schematic:

- 1 Set the record and source clips.
- 2 In the record timeline, select the element you want to replace, or place the positioner over the element.
- 3 Press **R**.

Performing a Three-Point Edit

A three-point edit is one in which a source clip is marked with both in and out points and a record clip is marked with either an in or out point. The points on the source clip mark the shot that is to be brought into the record clip, and the point on the record clip marks where it will go. The remaining material in the source clip is entered into the record clip as head and tail frames.

If you mark an in point on the record clip, the edit goes forward from that point. If you mark an out point on the record clip, the edit back-times from that point.

You can perform a three-point edit as either an insert or an overwrite edit.

You can also do a three-point edit with in and out points marked on the record clip, and either an in point or an out point marked on the source clip. In that case, the length of the source clip insert or overwrite is determined by the length between the in and out points on the record clip.

To perform a three-point edit:

- 1 Set the record and source clips.
- 2 Mark an in point and an out point on the source clip.
- 3 Mark an in point on the record clip for a forward-timed edit, or an out point for a back-timed edit.

NOTE Instead of marking an in point on the record clip, you can place the positioner at the frame where you want the forward edit to start.

4 Do one of the following:

- Press **I** for an insert.
- Press **O** for an overwrite.

The source clip is recorded to the timeline.

Performing a Four-Point Edit

In a four-point edit, in and out points are marked on both the source clip and the record clip. The in and out points on the source clip mark the material that will be used for the edit. The in and out points on the record clip mark where the source material will go.

You can perform a four-point edit as either an insert or an overwrite edit.

With an insert edit, if the source material differs in length from the marked duration of the record clip, the overall length of the record clip changes to accommodate the difference.

With an overwrite edit, the length of the record clip stays the same. The source material timewarps (expands or contracts) to fit into the space between the in and out points on the record clip.

If you do not want to create a timewarp when performing a four-point edit, disable the Auto Timewarp option in the Preferences menu. Excess source clip frames are brought in as head and tail frames. If there are fewer source clip frames, the source selection only overwrites the equivalent number of frames in the record clip, essentially treating the edit as a three-point edit.

When editing with audio, note the following:

- If the source clip has audio tracks, but the record clip does not, and you want to copy audio to the record clip, you must create empty audio tracks first.
- Audio track channel assignment is affected. For example, if you reassign the output of audio track 2 to track 1 in the source clip, that audio will be copied to track 1 in the record clip.
Refer to [Audio](#) on page 1195.

To perform a four-point edit:

- 1 Set the record and source clips.
- 2 Mark an in point and an out point on the source clip.
- 3 Mark an in point and an out point in the record clip.
- 4 Do one of the following:
 - To do a four-point insert edit, press **I**.

The material between the in point and the out point on the source clip is inserted and the edit sequence of the record clip changes length to accommodate any difference between the duration of the material between the source and record in and out points.

- To do a four-point overwrite edit, press **O**.

The material between the in point and the out point on the source clip is used in a fit-to-fill edit between the in and out points of the record clip. Also, a timewarp is applied if their lengths are different.

Removing Elements from an Edit Sequence

When you remove an element from an edit sequence gesturally, the effect depends on whether Ripple is on or off. When Ripple is off, you *lift* an element, leaving a gap in place of the lifted element.

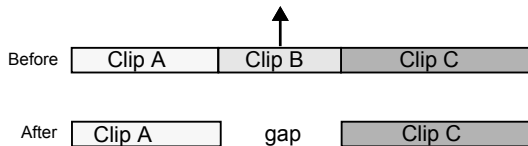

When Ripple is on, you *extract* an element, and the edit sequence collapses to fill the gap left by the extracted element.

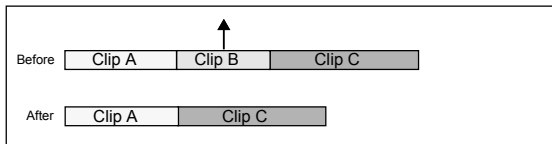

You can lift or extract elements from the timeline independently of the Ripple mode using hot keys.

To lift or extract an element from an edit sequence using hot keys:

- 1 Select the element you want to lift or extract or mark in and out points around the material.
- 2 Do one of the following:
 - Press **L** (period) to lift the element from the timeline, leaving a gap in place of the lifted element.
The lifted element is placed in the schematic.
 - Press **X** to extract the element from the timeline and ripple the remainder of the timeline to fill the gap.
The extracted element is placed in the schematic.

TIP To delete the element, hold down **Shift** when pressing the hot key.

To gesturally remove an element from an edit sequence:

- 1 Do one of the following:
 - Turn off Ripple to lift.
 - Turn on Ripple to extract.
- 2 Select the element that you want to lift or extract and drag it out of the timeline.

NOTE You can also lift or extract gaps on the timeline.

To gesturally copy an element to the schematic:

- 1 To copy the entire element, press **Alt+Shift** and drag the element to the schematic.
To copy the material between in and out points, press **Ctrl+'** to select the material and then press **Alt+Shift** and drag the element to the schematic.

Topics in this chapter:

- [About Vertical Editing](#) on page 1035
- [Vertical Editing Interface](#) on page 1036
- [Creating Layers](#) on page 1037
- [Layer Basics](#) on page 1038
- [Controlling the Transparency of Gaps](#) on page 1041
- [Working with Containers](#) on page 1041

About Vertical Editing

With vertical editing, you combine multiple stacked layers of one track into a single output. You can create complex effects using vertical transitions and soft effects.

All edits done with vertical editing are soft, so you can modify them at any time. By adding soft effects to your clips, you can create an entire edit without having to leave the timeline or process intermediate results.

Vertical editing can only be done between layers; it cannot be done between tracks.

If you import a multilayer clip from another Visual Effects and Finishing product, any compositing and soft effects between the layers are preserved. If you load

the clip back to another Visual Effects and Finishing product, all original edits are preserved as well as those from Flame.

Vertical Editing Interface

The following interface components are specific to working with layers for vertical editing. In this example, the clip is made up of three layers with various effects applied. All layers are on track V1.

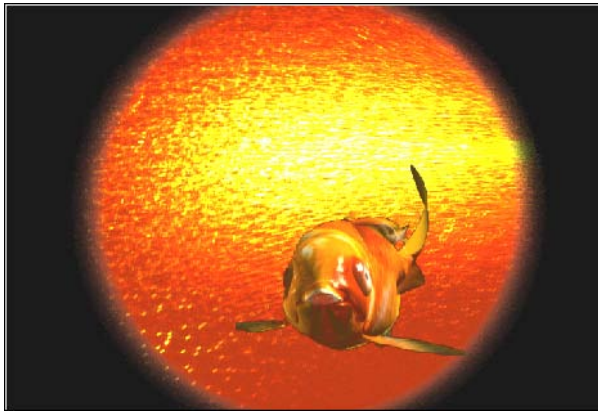

(a) Layer identifiers (b) Selector icons (c) Focus layer (d) Gap

Image courtesy of Quietman

Layer identifier Indicates the number of the layer and to which track it belongs.

Selector icon Selects a layer.

Focus layer Indicates the layer that has focus. All layers below the focus layer are included in the vertical edit. To change the focus layer, use the **Up Arrow** and **Down Arrow** to move the focus point.

Gap By default, all gaps are transparent, meaning clips on lower layers become visible in the edit. If you do not want to see through a gap, you can make it opaque. Opaque gaps are a light shade of grey.

Track shading To make it easier to identify groups of tracks and layers, the shading of tracks alternates between light and dark grey.

Creating Layers

Create as many layers as you need for vertical editing. Vertical editing works from the top layer to the bottom layer. Assign the topmost layer as the focus layer for it and all layers below it to be visible in the output.

To create a layer for vertical editing:

- 1 From a Batch timeline, do one of the following:
 - To add a layer above the current layer, click the L+ button.
 - To add a layer below the current layer, **Ctrl**-click the L+ button.

NOTE If you do not see the L+ button, make sure Editing is selected and enabled from the Menu Priority box.



An empty layer is created and it becomes the focus layer. Only the layers below it on the same track are visible in the output. In the following example, an empty layer is added above L2. Only the output below the new layer, L3, is visible in the output. The fish layer is not visible.

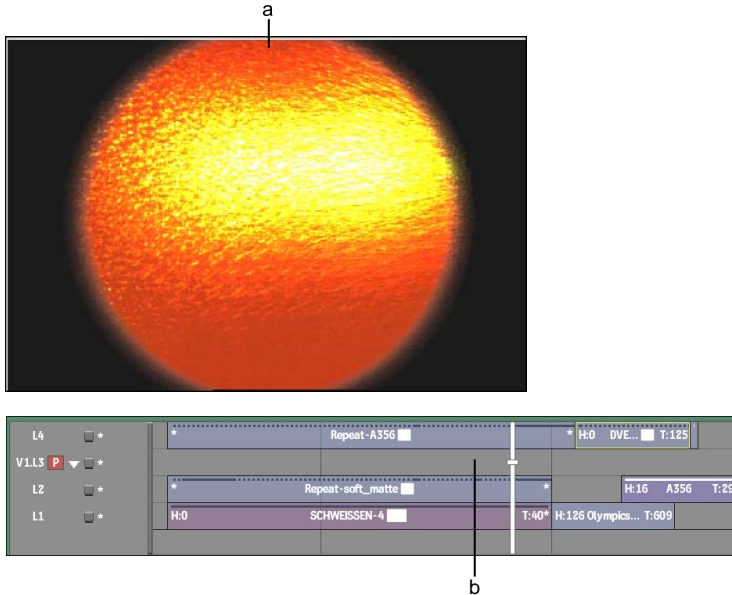

(a) Output of L1 and L2 (b) New layer

- 2 Add a clip or soft effects to the empty layer.
- 3 Press the **Up Arrow** to move the focus point to the topmost layer. The topmost layer becomes the focus layer, the channel indicator updates to the primary layer, and the image is updated.

Layer Basics

Collapse layers to help organize your timeline without affecting the results of your vertical edit. Mute layers to temporarily remove them from the vertical edit.

You can generate multilayer clips from EDLs as well as by importing AAF or FCP files created in third-party applications.

You make layers current as well as resize, select, name, and lock them in the same way as tracks. See [Track Basics](#) on page 978.

Collapsing Layers

If you have a track with more than one layer, collapse the layers into a single element to remove clutter from your timeline. You can still cycle through layers when they are collapsed.

You can also flatten timeline layers into a single committed layer that retains its soft properties (such as handles and dissolves). See [Merging Timeline Layers](#) on page 1183.

To collapse a group of layers:

- 1 Click the Collapse arrow.

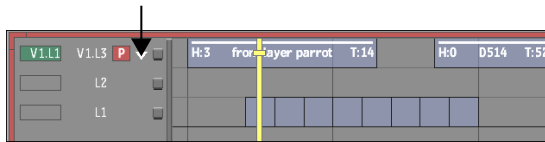

All layers are collapsed into a single track. The Collapse arrow changes to an Expand arrow to indicate the track contains collapsed layers.

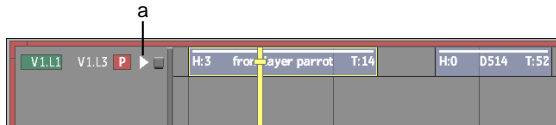

(a) Expand arrow

- 2 To cycle through each layer, click the Layer Selection icon to select all the layers and then press the **Up** or **Down Arrow** key.
The timeline and image window update to reflect the current layer.

NOTE To uncollapse the layers, click the Expand arrow.

Hiding Layers

Mute layers to temporarily hide them from the vertical edit. You can mute any layer except the topmost layer.

To mute a layer:

1 Do one of the following:

- To mute one layer, **Ctrl**-click the Layer identifier.
- To mute all layers in a track (except the topmost one), **Shift+Ctrl**-click a Layer identifier.

The identifiers of the muted layers turn yellow and the layers are removed from the output. In the following example, the output from L2 is muted, revealing the output from the next layer down—L1.

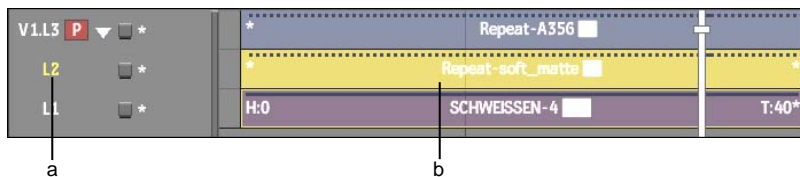

(a) Yellow identifier for muted layer (b) Layer hidden from output

Image courtesy of Quietman

-
- 2 **NOTE** To make layers visible again, **Ctrl**-click or **Shift+Ctrl**-click the Layer identifier.
-

Creating Multilayer Clips

You can automatically generate a multilayer clip using the multi-assemble options in the EDL module. You can load multiple EDLs and assign each EDL to a layer before assembly. See [Importing EDL Files](#) on page 321.

You can also create multilayer clips by importing AAF or FCP files from third-party applications. See [Importing AAF Files](#) on page 481 and [Importing Final Cut Pro XML](#) on page 431.

Controlling the Transparency of Gaps

Gaps are spaces in a layer that do not contain media. Create gaps to see through one layer to another or to apply soft effects to the layers below the gap. If a gap exists in a layer, the next layer that contains video media is included in the edit as long as it is also below the focus layer.

By default, all gaps are transparent. However, you can make a gap opaque if you do not want to see through to the next layer. You can only make gaps that do not contain soft effects opaque.

Also see [Creating Gap Effects](#) on page 1145.

To make a gap opaque:

- 1 Select the gap or move the positioner's focus point over the gap.
- 2 Enable Opaque.

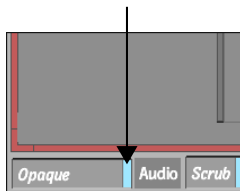

Working with Containers

Containers are a convenient way to group elements on the timeline and remove clutter from the timeline. The elements, which can come from different layers or tracks, are treated as one unit yet remain individually editable. Containers behave like any other element but they appear on a separate

timeline when you enter their editor. You can add an unlimited number of containers to a container.

You can add soft effects to an entire container or to any of its contents but not Batch FX. For example, create a container for a front and back clip and apply a soft text to the container. Within the container, colour correct the front and back clips individually.

Containers can also be used to take a clip and matte that are separate and add them to the timeline as a single element. See [Creating Matte Containers](#) on page 1123.

You can create containers directly inside of Batch or load clips with containers from another Visual Effects and Finishing product.

NOTE You cannot contain audio across tracks, but you can contain adjacent audio elements.

To create a container:

- 1 Select all the tracks or layers on the timeline that you want to collapse into the same container.

NOTE The bottom layer will always be trimmed out so that you can dissolve from an element to a container.

- 2 Enable Container.

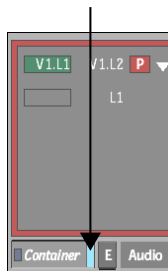

All the selected elements are collapsed into a container and the element changes to a dark blue. If you did not make any selections and you have in and out points, the container is created between the in and out points.

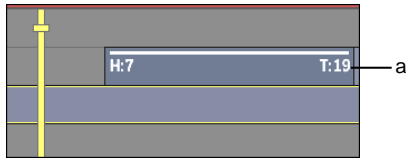

(a) Container

- 3 To edit the contents of the container individually, double-click the container, or click E beside the Container button.

TIP If you do not see the Container button, select the container.

The layers in the container appear on their own timeline. The duration of the container is indicated by yellow marks.

To edit or apply a soft effect to a layer, you must select the layer. Moving the focus point does not change the layer displayed in the viewport. Both layers are displayed as one element.

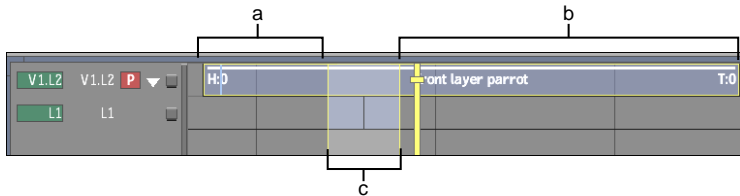

(a) Head frames of front layer (b) Tail frames of front layer (c) Duration of layers in container

To remove a container:

- 1 Select the container.
- 2 **Alt**-click the LED on the Container button.
The container is removed from the timeline and its contents are restored to the main timeline.

Trimming Shots

43

Topics in this chapter:

- [About Trimming](#) on page 1045
- [Trimming Examples](#) on page 1048
- [Head, Tail, and Offset Information](#) on page 1049
- [Using the Trim Cursors](#) on page 1051
- [Locking Segments While Trimming](#) on page 1051
- [Linking Transitions and Cuts](#) on page 1052
- [Keyboard Trimming](#) on page 1053
- [Trimming Segments Gesturally](#) on page 1054
- [Trimming Dissolves](#) on page 1058
- [Trimming Audio Tracks](#) on page 1059
- [Sliding a Segment](#) on page 1059
- [Slipping a Segment](#) on page 1062
- [Trim Cursor Review](#) on page 1063

About Trimming

Trimming is the process of adding or removing frames from the beginning or end of a clip in order to change its duration. Trimmed frames are not physically removed from the clip, but rather are stored in areas referred to as the head and the tail of the clip, where they can be reapplied to the clip by further trimming

at any time. Certain operations, however, such as consolidating or committing a clip, permanently remove head and tail frames from the framestore.

You can also slip and slide clips, and slide transitions. When you slip or slide a clip or slide a transition, you only modify the head or tail frames or the in and out points to change the frames that appear in the final edit. You do not change the duration.

You can trim clips in the timeline in the Player and in the timeline in Batch.

NOTE For recommendations on which editing tool to use for different purposes, see [Editing Essentials](#) on page 927.

Types of Trim Operations

When trimming, slipping and sliding clips, different cursors indicate the type of operation. Trim cursors appear on timeline elements when Trim mode is enabled. The following illustration shows the trim cursors and the locations on the frame where they appear.

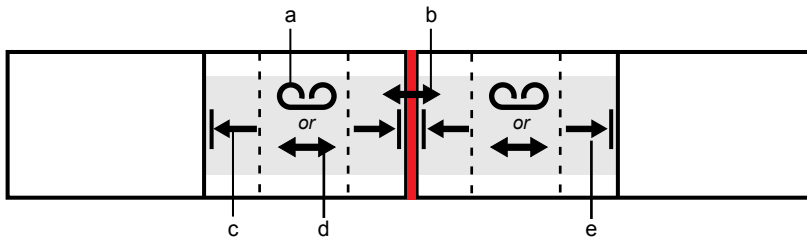

(a) Slip (b) Slide transition (c) Trim head (d) Slide shot (e) Trim tail

Name	Cursor	Description
Trim Head		Trims frames into or out of the head of the shot.
Trim Tail		Trims frames into or out of the tail of the shot.
Slide		Simultaneously trims frames into and out of the head and tail of shots or the head and tail on either side of transitions. When sliding shots, the length of the shot remains the same, but the head and tail frames used change, and adjacent shots get

Name	Cursor	Description
		trimmed. When sliding transitions, the location of the transition slides left or right.
Slip		Simultaneously trims frames into and out of the head and tail of shots. The transitions remain where they are, but the shot is slipped forward or backward, and remains the same length. To display the Slip cursor, when the Slide cursor is visible press Alt+.

Gestural and Hot Key Trimming

You can trim, slip, and slide video and audio elements in one or more tracks in the timeline. You can either trim elements gesturally or using keyboard hot keys. Gestural trimming can only take place when the Trim button is enabled. Keyboard trimming is available regardless of the status of the Trim button.

Effects of Trim Operations

The following illustration shows the effect of various trim operations. Note that these are conceptual representations of trimming operations and are not meant to be visual reproductions of the actual shots.

Before

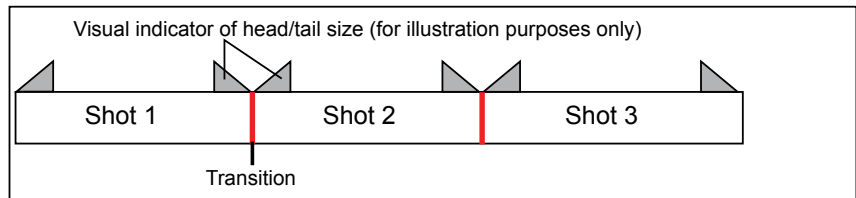

After

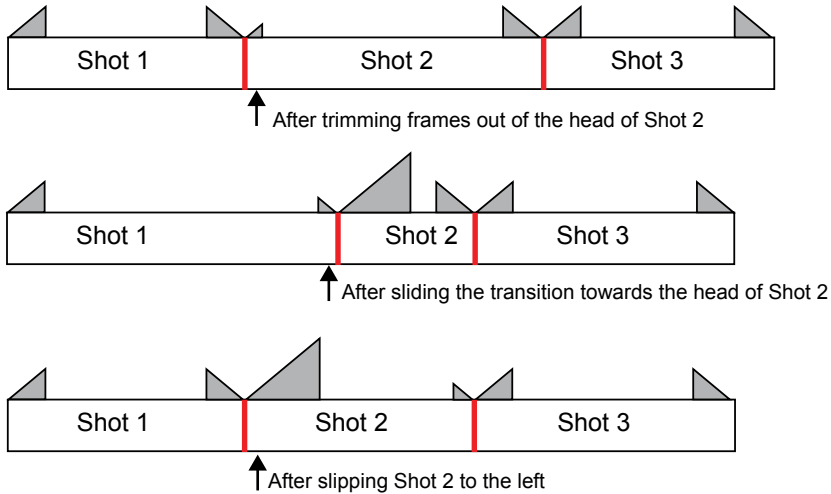

Trimming Examples

This section contains examples that illustrate the effects of various five-frame trim operations. The numbers in the illustrations refer to the number of frames in the segment's head and tail. Before trimming, the segments in the edit sequences are numbered "H:10 - T:10," indicating that each segment has a 10-frame head and a 10-frame tail. Changes to the head and tail count are underlined in the illustrations for emphasis. The visual indicators in the following screenshots are for illustration purposes only.

NOTE The illustrations in this section are conceptual representations of the timeline, and are not meant to be exact reproductions. Throughout this section, references are made to the video track, but the trim operations described also work on audio tracks.

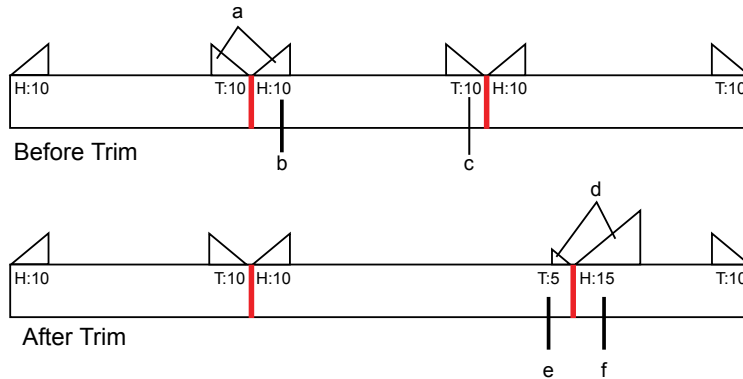

(a) Visual indicator of head/tail size (b) 10 frames are in the head (c) 10 frames are in the tail (d) Visual indicator of the change in head/tail size (e) Result of 5 tail frames trimmed into clip (f) Result of 5 frames trimmed out of clip and into the head

There are several variables that affect what happens when you perform trim operations, such as the status of Link Cut/Transition mode, Ripple mode, and Trim Lock mode. Most illustrations show the effect of the trim operation both when Ripple is on and off, and when Trim Lock is on and off. Not all Link status variations are illustrated. Unless otherwise noted, assume that Link Cut is enabled.

For information on:	Refer to:
Ripple Mode	Setting the Ripple Mode on page 1021.
Trim Lock mode	Locking Segments While Trimming on page 1051.
Link Cut/Transition mode	Linking Transitions and Cuts on page 1052.

Head, Tail, and Offset Information

Head, tail, and offset information of elements in the timeline is provided as illustrated. View this information by holding **Alt** and clicking an element. You can also expand the track in the timeline to see the track information.

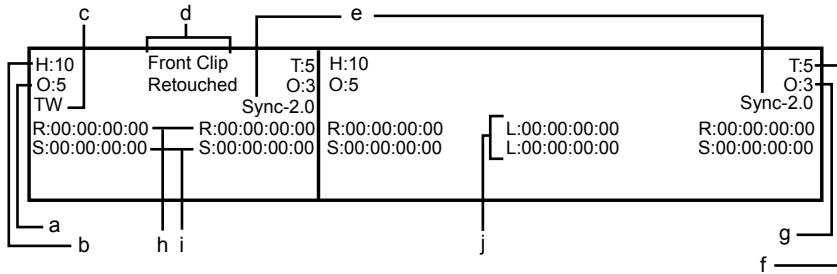

(a) Head offset (b) Head frame count (c) Timewarp (d) Clip/segment name (e) Edit sync offset (f) Tail frame count (g) Tail offset (h) Record timecode (head and tail) (i) Source timecode (head and tail) (j) Record and Source clip duration

Head and Tail Frames

Head and tail frames are soft properties of a segment. These frames are part of the original clip, but are not used in the current edit sequence. Blending transitions such as dissolves make use of head and tail frames for the extra frames required.

Offsets

Offsets are reference numbers that indicate the change, in frames, that takes place when you trim. Offsets are displayed at both the head and tail of each segment.

Trimming heads or tails towards the left on the timeline results in a negative offset and trimming towards the right results in a positive offset. Offsets are created as follows.

Offset	Action	Result Offset
Head Offsets	Trimming frames out of a segment's head	Negative
Head Offsets	Trimming frames into a segment's head	Positive
Tail Offsets	Trimming frames out of a segment's tail	Positive
Tail Offsets	Trimming frames into a segment's tail	Negative

For example, if you trim 10 frames out of a segment's head, the offset at the head of that segment is -10. If you trim 10 frames into a segment's head, the offset at the head of the segment is 10.

Using the Trim Cursors

In the timeline, the various trim cursors appear when the cursor is in an appropriate area for trimming. The following illustration shows the trim cursors and their locations.

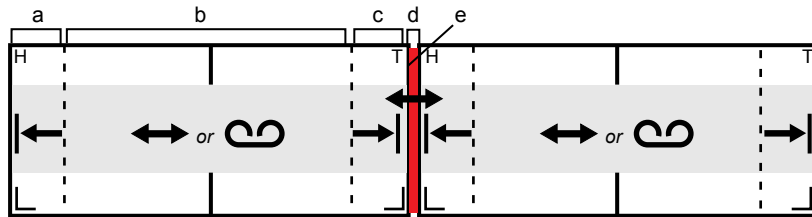

(a) Trim Head cursor (b) Slide or Slip cursor (c) Trim Tail cursor (d) Slide cursor (e) Transition

Note the following when using the Trim Head or Trim Tail cursors:

- Dragging in the direction of the arrow adds frames to the element.
- Dragging away from the direction of the arrow removes frames from the element.

Locking Segments While Trimming

Frames are added or removed from either the head or the tail of the segment, depending on the location of the cursor and whether Lock is enabled or disabled.



(a) Lock button

When Lock is enabled, the segment or transition under the cursor is locked to the cursor, so the trim occurs at the other end of the segment. Locking segments controls whether the head or tail frames are affected during trimming.

This is useful if you want to trim without affecting transitions such as dissolves. Clip information such as number of head and tail frames appears in black on selected segments.

Cursor	Effect of Using Trim Lock
Trim Tail	The tail is locked, so the head of the segment is trimmed.
Trim Head	The head is locked, so the tail of the segment is trimmed.
Slide	The head and tail of the segment being trimmed are locked, so the head and tail of the connecting segments are trimmed.
Slide Transition	The head and tail of the transition being trimmed are locked, so the head and tail of the connecting segments are trimmed.
Slip	No effect.

The effects of using Lock are illustrated in the trimming operations throughout this section.

NOTE When trimming timewarps, there is a third lock option—Both. See [Trimming a Timewarp](#) on page 1168.

Linking Transitions and Cuts

Use the Link buttons to affect how dissolves and cuts behave during slide and trim operations.

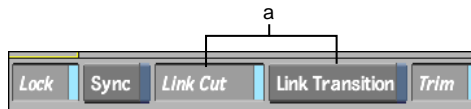

(a) Link buttons

Depending on the Link option that is enabled, the transition or cut is linked to the element being slid or trimmed. This is useful if you have transitions such as dissolves that you want to keep with the trimmed element. For examples of slide operations using Link Transition and Link Cut, see [Trimming Dissolves](#) on page 1058.

From the Batch timeline, the Link options also have an effect when copying and moving clips with dissolves to the Batch schematic:

- When Link Cut is enabled, or both options are disabled, the dissolve is not copied with the clip.
- When Link Transition is enabled, the dissolve is copied with the clip.

Keyboard Trimming

You can do most trimming operations with keyboard hot keys. Note that when trimming with keyboard hot keys, the Trim, Lock, Ripple, and Link settings have the same effect in keyboard trimming as in gestural trimming.

To trim a segment or transition with the keyboard:

- 1 Select the segment or transition you want to trim.
- 2 Press and hold the Trim Tail (.), Trim Head (,), Slide Element (/), Slide Transition (;) or Slip Element (**Alt**+/) key.
- 3 While holding the applicable trim key, press the **Left arrow** or **Right Arrow** key to add or subtract frames from the item being trimmed.

TIP You can hold the **arrow** key to continuously trim.

Trim to Mark

You can use a number of hot keys to trim or slide a segment to an in point, to an out point, or to the positioner.

To trim or slide to the positioner:

- 1 Select the element you want to trim or slide.
- 2 Move the positioner to the location where you want to trim or slide.
- 3 Use the trim hot key for the operation you want to perform:

To:	Press:
Trim the head to the positioner	,+Spacebar
Trim the tail to the positioner	.+Spacebar

To:	Press:
Slide a transition to the positioner	;+Spacebar

If the element has enough handles, it is trimmed or slid to the positioner. Otherwise, it is trimmed or slid as close to the specified frame as possible.

To trim or slide to an in or out point:

- 1 Select the element you want to trim or slide.
- 2 Set an in or out point at the location where you want to trim or slide.
- 3 Use the trim hot key for the operation you want to perform.

To:	Press:
Trim the head to the in point	,+[
Trim the head to the out point	,+]
Trim the tail to the in point	.+[
Trim the tail to the out point	.+]
Slide a transition to the in point	;+[
Slide a transition to the out point	;+]

If the element has enough handles, it is trimmed or slid to the in or out point. Otherwise, it is trimmed or slid as close to the specified frame as possible.

Trimming Segments Gesturally

You can use the Trim Tail and Trim Head cursors for gestural trimming.

NOTE To trim elements on a track, the track cannot be locked.

To trim five frames into a segment using the Trim Tail cursor:

- 1 Enable Trim.
- 2 Position the cursor at the tail of the segment.

The Trim Tail cursor appears.

3 Drag right five frames.

TIP Alternatively, with the segment selected and the trim cursor visible, press **Ctrl+Alt** and click the segment. The numeric keypad appears. Enter the number of frames by which you want to trim the tail. To increase the number of tail frames, enter a positive number, and to reduce the number of tail frames, enter a negative number.

The results, which vary according to how Lock and Ripple are set, are shown in the following illustration. Underlined numbers indicate trimmed heads and tails.

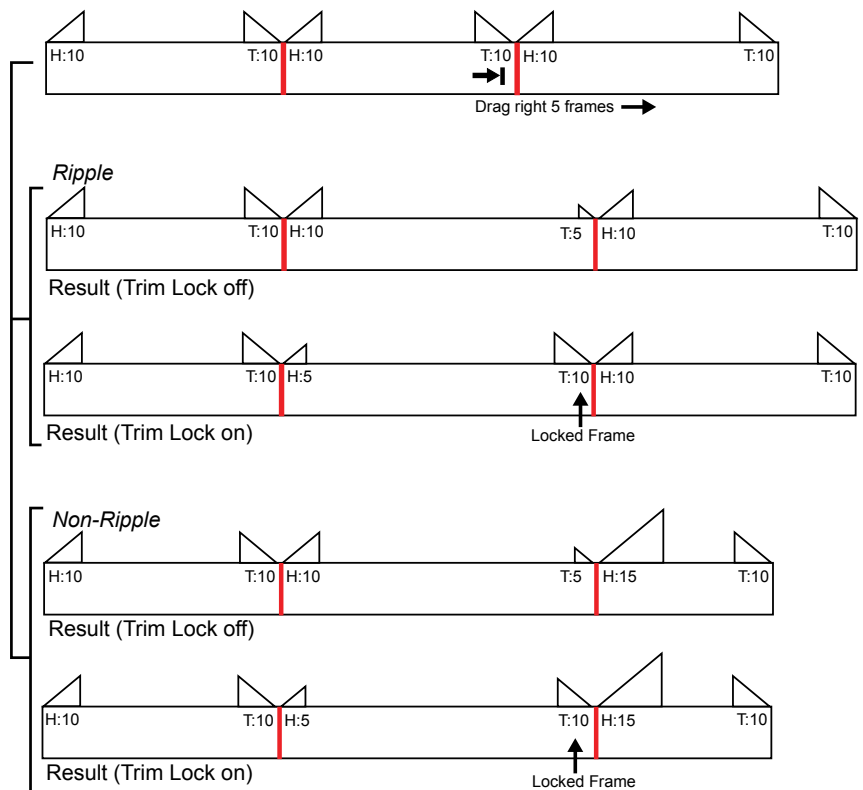

To trim five frames out of a segment using the Trim Tail cursor:

1 Enable Trim.

2 Position the cursor at the tail of the segment.

The Trim Tail cursor appears.

3 Drag left five frames.

The results, which vary according to how Trim Lock and Ripple are set, are shown in the following illustration. Underlined numbers indicate trimmed heads and tails.

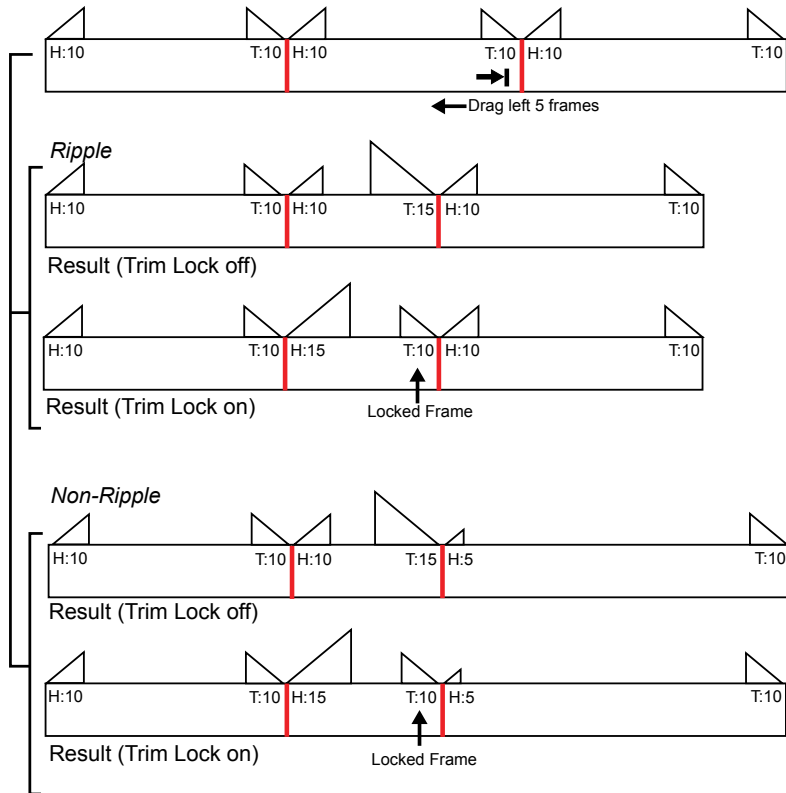

To trim five frames into a segment using the Trim Head cursor:

1 Enable Trim.

2 Position the cursor at the head of the segment.

The Trim Head cursor appears.

3 Drag left five frames.

The results, which vary according to how Trim Lock and Ripple are set, are shown in the following illustration. Underlined numbers indicate trimmed heads and tails.

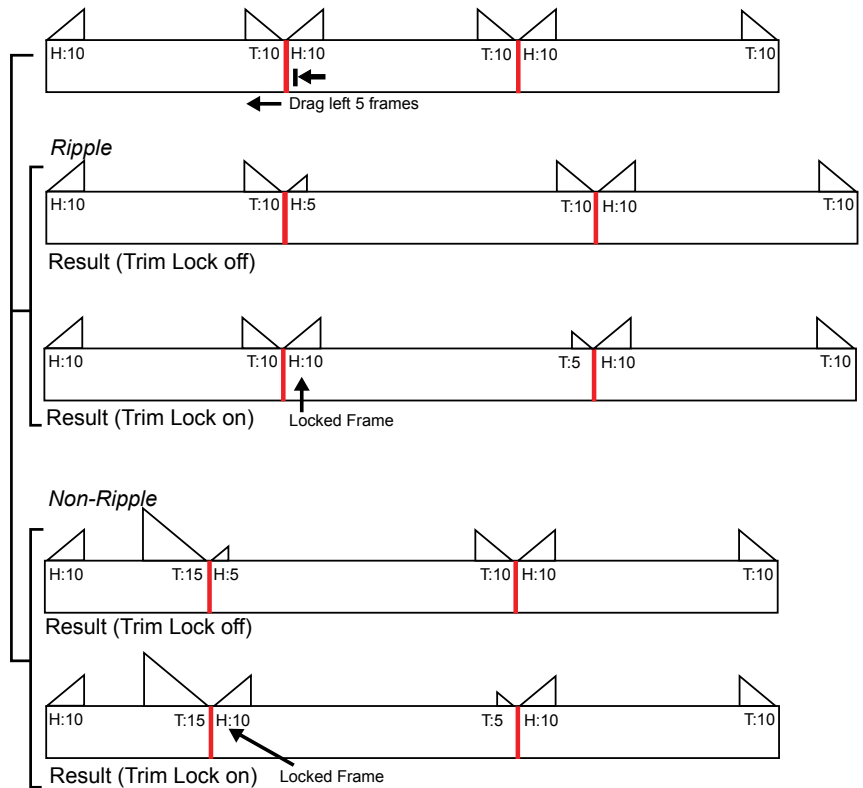

To trim five frames out of a segment using the Trim Head cursor:

- 1 Enable Trim.
- 2 Position the cursor at the head of the segment.
The Trim Head cursor appears.
- 3 Drag right five frames.

The results, which vary according to how Trim Lock and Ripple are set, are shown in the following illustration. Underlined numbers indicate trimmed heads and tails.

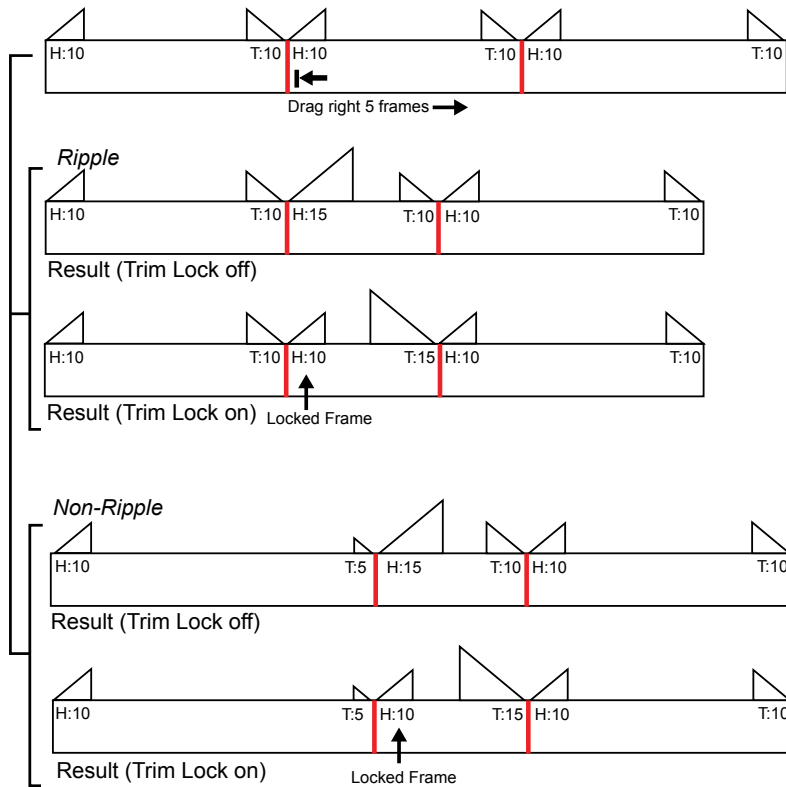

Trimming Dissolves

You can trim transitions containing dissolves. You can trim the segments on either side of the dissolve, and you can trim the dissolve itself (that is, increase or decrease the duration of the dissolve).

The following examples use the same three-segment sequence used throughout this section. In these cases, however, an eight-frame centred dissolve has been added to one of the transitions. As the dissolve uses four head and four tail frames, the head and tail on the surrounding segments in the “before” cases have been reduced from ten to six.

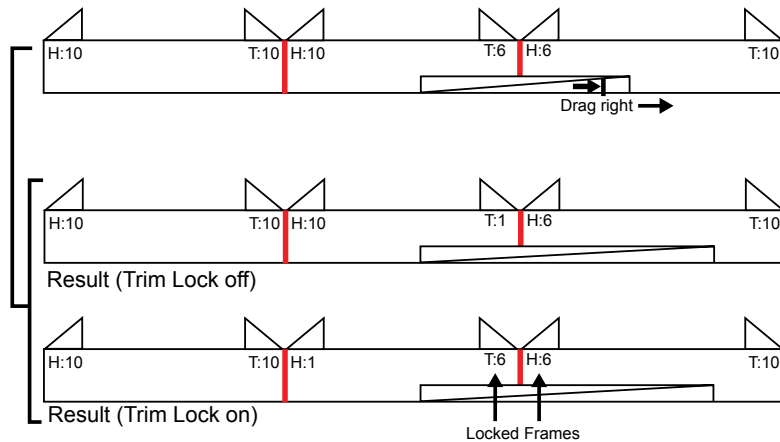

Edit sequence does not ripple when a transition is trimmed.
 Link Transition and Link Cut have no effect when trimming a transition.

Trimming Audio Tracks

You trim audio tracks in the same way as you trim video. You can trim any combination of audio and video segments.

Audio tracks are divided into subframes. There are 100 subframes of audio for every frame of video. When trimming audio tracks gesturally, you can trim on a subframe basis.

NOTE You cannot trim on a subframe level when simultaneously trimming audio and video tracks.

To trim audio on a subframe basis:

- 1 Select Sub-frame Pos in the Timeline preferences.
- 2 Hold down the **Shift** key while performing any of the trimming procedures described in [Trimming Segments Gesturally](#) on page 1054.

Sliding a Segment

Sliding changes a segment's position in the edit sequence. It simultaneously slides the segment under the cursor and trims the head and tail of the surrounding segments. With Trim Lock off, the head and tail of the slid

segment are trimmed. With Trim Lock on, the head and tail of the slid segment are not trimmed.

NOTE Sliding is a non-rippling action. The total length of the edit sequence does not change.

To slide a segment using the Slide cursor:

- 1 Enable Trim.
- 2 Position the cursor on the segment that you want to slide.
The Slide cursor appears.
- 3 Drag right or left.

TIP Alternatively, with the segment selected and the Slide cursor visible, press **Ctrl+Alt** and click the segment. The numeric keypad appears. Enter the number of frames by which you want to slide the segment. To slide the segment to the left, enter a negative number, and to slide it to the right, enter a positive number.

The results of dragging right, which vary according to how Trim Lock is set, are illustrated below. Underlined numbers indicate trimmed heads and tails. Dragging left produces similar (but inverse) results.

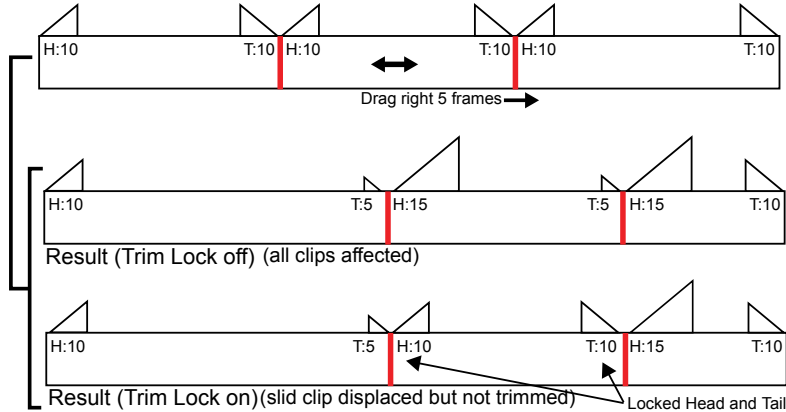

Sliding a Splice or Transition

When sliding a selected splice or transition in the timeline, the slide operation works on that splice or transition only. It does not affect the splices and transitions at either end of the segment.

To slide a splice or transition using the Slide cursor:

- 1 Enable Trim.
- 2 Position the cursor on the splice or transition that you want to slide.
The Slide cursor appears.
- 3 Drag right or left.

The results of dragging right, which vary according to how Trim Lock is set, are shown in the following illustration. In the illustration, a splice is slid five frames to the right when Trim Lock is on and off. Underlined numbers indicate trimmed heads and tails. Dragging left produces similar (but inverse) results.

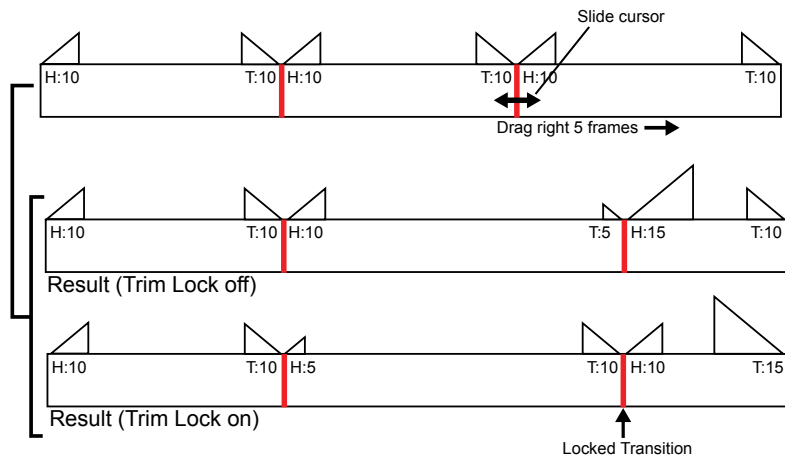

The following illustration shows the effect of sliding a dissolve five frames to the right. In this example, assume that both Ripple and Trim Lock are off. Use the results as a guide when trying other combinations.

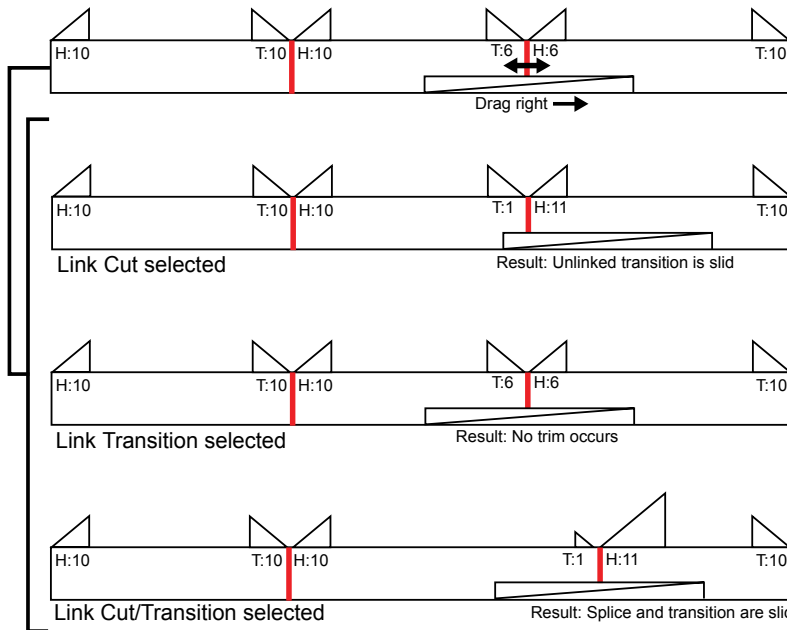

NOTE If you slide a dissolve or wipe with Ripple, Link Transition, and Link Cut all on, this combination of variables causes the same effect as a standard trim on the linked elements. The edit sequence ripples, as this is not a true dissolve or wipe slide.

Sliding Audio

You can slide audio segments in the timeline on a subframe basis by holding down the **spacebar** while sliding.

If you select a video segment with a group of audio subframes, you cannot slide on a subframe basis.

Slipping a Segment

Slipping simultaneously trims the head and tail of the segment without changing its position in the edit sequence. The duration of the segment is not altered. Other segments in the edit sequence are not affected and the total duration of the sequence does not change.

To access the Slip cursor, hold down **Alt+** when the Slide cursor is visible.

The following illustration shows the result of slipping a segment to the left and right. Note that the result is the same, regardless of the Trim Lock setting. In both cases, only the head and tail of the slipped segment are trimmed. The underlined frame numbers indicate where the trim has taken place.

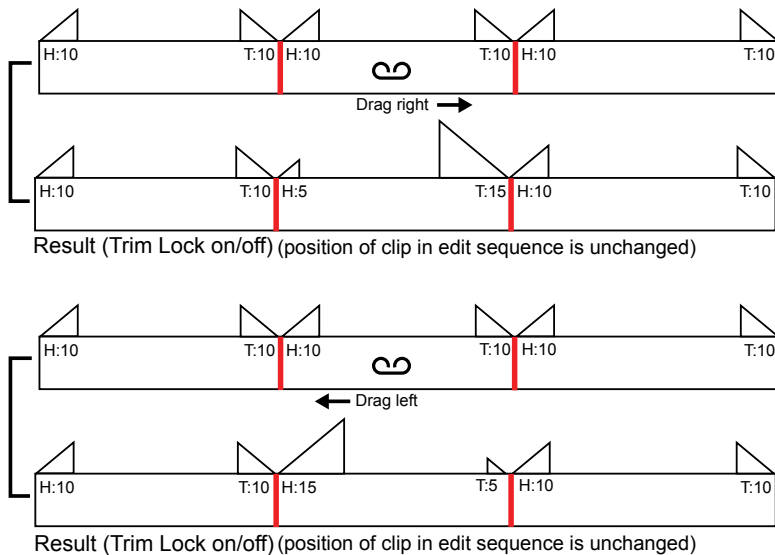

Slipping Audio





You can slip audio segments in the timeline on a subframe basis. To slip audio by subframes, hold the **Shift** key while you slip.

If you select a video segment with a group of audio subframes, you cannot slip on a subframe basis.

Trim Cursor Review

When Ripple is enabled, the following trim cursors are red. When Ripple is disabled, the trim cursors are green. The Slip trim cursor is the only one that remains green since slipping does not change the duration of the edit sequence.

Cursor	Action
	Drag right to add frames to the tail of a segment. Drag left to remove frames from the tail of a segment. (Locked) Drag right to add frames to the head of a segment.

Cursor	Action
 Trim Head	(Locked) Drag left to remove frames from the head of a segment.
 Slide	Drag right to slide a segment forward. Drag left to slide a segment backward.
 Slip	Drag right to slip a segment forward. Drag left to slip a segment backward. (Hold Alt+ when the Slide cursor is visible to see this cursor.)
 Symmetrical Trim	Drag left or right to trim the same amount from the head and tail. (Hold Shift+M to see this cursor.)

Topics in this chapter:

- [About Dissolves and Wipes](#) on page 1065
- [Creating Dissolves on the Desktop](#) on page 1066
- [Creating Dissolves on the Timeline](#) on page 1078
- [Creating Wipes](#) on page 1082
- [Using the Wipe Schematic](#) on page 1094
- [Using Templates for SMPTE Wipes](#) on page 1104
- [Creating an Axis Transition](#) on page 1107
- [Copying Transitions](#) on page 1109

About Dissolves and Wipes

Dissolves are blending transitions between timeline elements in which the first clip fades out at the same time as the second clip fades in. Wipes are non-blending transitions that use masks to hide or reveal the outgoing and incoming shots.

You can create several types of transitions, including SMPTE and axis transitions. To create a transition, you must have enough head and tail frames in the outgoing and incoming shots.

Create Wipes through the Batch or Player timeline. Create dissolves through:

- The Dissolve menu on the desktop
- The timeline in the Player
- The timeline in Batch

NOTE For recommendations on which editing tool to use for different purposes, see [Editing Essentials](#) on page 927.

Using the Dissolve Editor, you can vary the rate of the dissolve by modifying a curve. The Dissolve Editor is available from the Dissolve menu, Player timeline, and Batch timeline.

You can also create audio fades or crossfades. See [Creating Audio Fades in the Timeline](#) on page 1209. Audio dissolves are linear only so you cannot modify the rate using the Dissolve Editor.

Creating Dissolves on the Desktop

On the desktop, you can create a dissolve or crossfade between two source clips that are not spliced together. A crossfade is similar to a dissolve, but it allows you to specify the dissolve duration. The two source clips must be of the same resolution, bit depth, and aspect ratio. As well, you can create a fade-in or fade-out to black using one source clip.

Accessing the Desktop Dissolve Menu

You access the Dissolve menu before creating the dissolve.

To access the Dissolve menu:

- 1 In the Main menu, click Editing, and then click Dissolve.
The Dissolve menu appears.

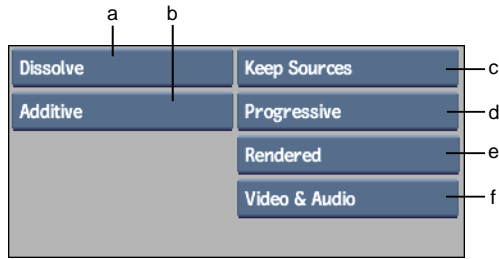

(a) Dissolve Type box (b) Dissolve Mode box (c) Keep/Delete Sources box
 (d) Render Type box (e) Render Mode box (f) Video/Audio option box

The Dissolve options are described as follows.

Dissolve Type box Select the type of dissolve you want to create. The Dissolve and Crossfade options both dissolve between two clips, but the Crossfade option gives you more control over the dissolve duration and selection criteria.

Select:	To:
Dissolve	Create a dissolve between two clips. The dissolve duration is based on the frame you select in the incoming clip. See Dissolving between Two Clips on page 1069.
CrossFade	Create a dissolve between two clips. You can choose the dissolve duration and the criteria used when selecting clips. See Crossfading between Two Clips on page 1071.
Fade In	Create a dissolve that fades from a black source to a clip. See Creating a Fade-in or Fade-out on page 1072.
Fade Out	Create a dissolve that fades from a clip to a black source. See Creating a Fade-in or Fade-out on page 1072.
Mix	Mix the pixels between two clips based on a percentage you specify in the Mix menu. See Mixing Source Clips on page 1075.

Render Type box Specify how to render the dissolve—in frames (Progressive) or fields (Interlaced).

Dissolve Mode box Specify how the pixels of the source clips are combined to produce the corresponding pixels of the new clip.

Select:	To:
Additive	Add the colour value of a pixel in the first source clip to the colour value of the corresponding pixel in the second source clip. This value is assigned to the pixel in the resulting dissolve.
Nonadditive	Evaluate corresponding pixels in the first and second source clips to determine which has the higher colour value. The pixel in the resulting dissolve is assigned the higher of the two values.
Inverse Non-additive	Evaluate corresponding pixels in the first and second source clips to determine which has the lower colour value. The pixel in the resulting dissolve is assigned the lower of the two values.

Dissolve Alignment box This box appears when you select CrossFade, Fade In, or Fade Out as the dissolve type. Select the alignment used when selecting the outgoing and incoming clips for the dissolve.

Select:	To use:
Start Point	The starting frame of the transition in both the outgoing and incoming clip.
Mid Point	The middle frame of the transition in both the outgoing and incoming clip.
End Point	The end frame of the transition in both the outgoing and incoming clip.

Dissolve Duration field This field appears when you select CrossFade, Fade In, or Fade Out as the dissolve type. Specify the number of frames over which the dissolve occurs. For example, if the dissolve duration is set to 10, the dissolve takes place over 10 frames.

Render Mode box Specify whether or not dissolves are rendered.

Select:	To:
Rendered	Render the dissolve.

Select:**To:**

Unrendered Not render the dissolve. Dissolves remain unprocessed until Force Render is selected. Select Unrendered if you want to edit the dissolve in the timeline without having to wait for it to be rendered.

When you select Unrendered, a black frame with the message “Unrendered Frame” is substituted for a rendered frame when a dissolve is created or when it is modified in the timeline.

If your system is capable of creating real-time dissolves and you are modifying a dissolve in Unrendered mode, the dissolve is shown in the image window when the clip is played. The dissolve is not shown on the timeline.

Keep/Delete Sources box Specify whether you want to keep the source clips or remove them from the desktop after creating the dissolve.

Video and Audio box If a clip has audio tracks, you can add a dissolve to both video and audio tracks at the same time. If you select the Video and Audio options when adding a dissolve, crossfade, or fade-in/out, the dissolve or fade is added to both video and audio tracks. If you select the Video option, the dissolve or fade is only added to the video track.

NOTE You cannot add a dissolve or fade to audio tracks independently of video tracks.

Dissolving between Two Clips

When you create a dissolve between two clips, the first source clip you select is the outgoing clip and the second source clip is the incoming clip.

The number of frames over which the dissolve occurs is specified by the dissolve duration. The dissolve duration is set when you select a frame in the incoming clip; the number of the selected frame relative to the first frame in the clip is used as the dissolve duration. For example, if you select frame 10, the dissolve duration will be 10 frames.

In the following example, the fourth frame in the incoming clip is selected. As a result, the dissolve duration is set to four.

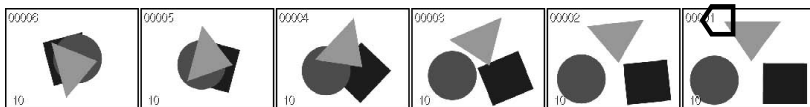

Action: Select the outgoing clip.

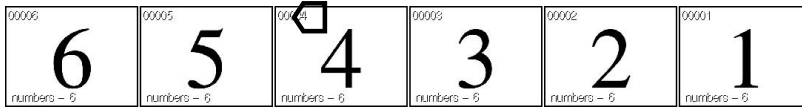

Action: Select the incoming clip. The dissolve duration is set to 4.

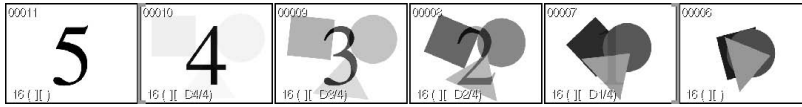

Result: The dissolve across four frames.

To create a dissolve:

- 1 Click Dissolve in the Editing menu.
- 2 Select Dissolve from the Dissolve Type box.
- 3 Set the dissolve options. See [Accessing the Desktop Dissolve Menu](#) on page 1066.
- 4 Select the first source clip. The first source clip is the outgoing clip.
- 5 Select the second source clip. The second source clip is the incoming clip. The number of the frame that you select in the incoming clip specifies the dissolve duration.

An “E” (for Editor) appears on the Dissolve button after you select the second clip. To use the Dissolve Editor, click the Dissolve button again. See [Creating Complex Dissolves with the Dissolve Editor](#) on page 1073.

- 6 Select a destination reel.

A new clip containing the dissolve appears on the destination reel. The length of the clip can be determined using the following equation:

$$(\text{length of outgoing clip}) + (\text{length of incoming clip}) - (\text{dissolve duration})$$

The dissolve is indicated on the proxy with the label D(n/m), where n is the frame's position in the dissolve and m is the length of the dissolve. For example, for a 10-frame dissolve, the first frame is labelled D(1/10) and the last, D(10/10).

Crossfading between Two Clips

A crossfade is the same as a dissolve but gives you more control over the duration of the dissolve and the portions of the clips that are used for the crossfade.

Examples of creating a crossfade using the start, middle, and end alignments are shown as follows.

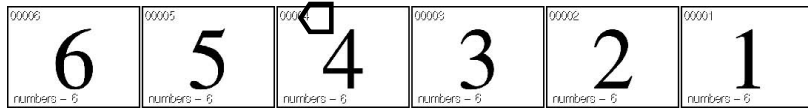

Action: Select the start, mid, or end point of the dissolve in the outgoing clip.



Action: Select the start, mid, or end point of the dissolve in the incoming clip.



Result: The dissolve using the start point. The dissolve duration was set to 4.



Result: The dissolve using the mid point. The dissolve duration was set to 4.



Result: The dissolve using the end point. The dissolve duration was set to 4.

To create a crossfade:

- 1 Click Dissolve in the Editing menu.
- 2 Select Crossfade from the Dissolve Type box.
The crossfade options appear.

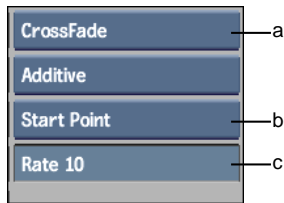

(a) Dissolve Type box (b) Dissolve Alignment box (c) Dissolve Duration field

- 3 Set the dissolve options. See [Accessing the Desktop Dissolve Menu](#) on page 1066.
- 4 Select the frame in the outgoing clip that will be the start, middle, or end of the dissolve.
- 5 Select the frame in the incoming clip that will be the start, middle, or end of the dissolve.

An “E” (for Editor) appears on the Dissolve button after you select the second clip. To use the Dissolve Editor, click the Dissolve button again. See [Creating Complex Dissolves with the Dissolve Editor](#) on page 1073.

- 6 Select the destination reel.
If the “E” button is enabled, the Dissolve Editor appears. Otherwise, the crossfade is added to the destination reel.

Creating a Fade-in or Fade-out

In a fade-in or fade-out, the outgoing clip (fade-in) or incoming clip (fade-out) is a black source.

To create a fade-to-black or fade-from-black:

- 1 Click Dissolve in the Editing menu.
- 2 Select either Fade In or Fade Out from the Dissolve Type box.
The fade options appear.

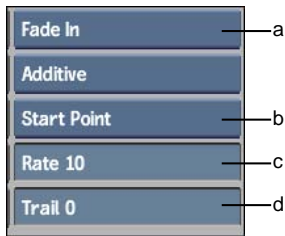

(a) Dissolve Type box (b) Dissolve Alignment box (c) Dissolve Duration field
(d) Trail field

- 3 Use the Trail field to enter the number of pure black frames to place before or after the fade-in or fade-out, respectively.
- 4 Set the dissolve options. See [Accessing the Desktop Dissolve Menu](#) on page 1066.
- 5 Select the frame in the source clip that will be the start, middle, or end of the fade-in or fade-out.
An “E” (for Editor) appears on the Dissolve button after you select the source clip. To use the Dissolve Editor, click the Dissolve button again. See [Creating Complex Dissolves with the Dissolve Editor](#) on page 1073.
- 6 Select the destination reel.
If the “E” button is enabled, the Dissolve Editor appears. Otherwise, the fade-in or fade-out is added to the destination reel.

Creating Complex Dissolves with the Dissolve Editor

Use the Dissolve Editor to create complex dissolves. For example, instead of having a gradual fade-in of the incoming clip, you can make your clip fade in, fade out, then fade in again.

NOTE The curve in the Dissolve Editor can be used only on video dissolves.

To create a complex dissolve:

- 1 Click Dissolve in the Editing menu and select the two source clips in the desktop reels.
An “E” (for Editor) appears on the Dissolve button.
- 2 Click Dissolve.

The “E” on the Dissolve button is highlighted.

3 Select the destination reel.

The Dissolve Editor appears.

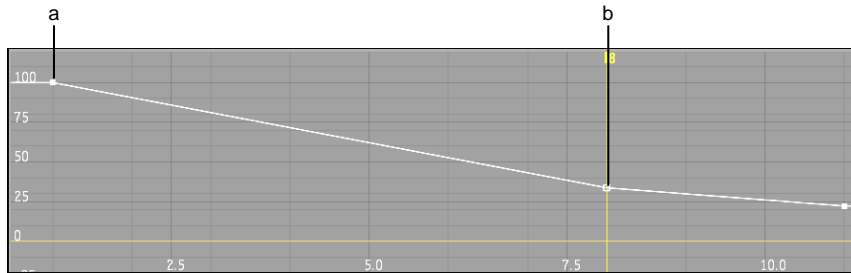

(a) Boundary key (b) Boundary key

The graph plots the frame number of the result clip (on the horizontal axis) against the mix percentage (on the vertical axis). The default linear curve represents a gradual dissolve across the number of frames specified by the dissolve duration.

4 The mix percentage values for one frame specify the amount of the incoming and outgoing clip used in the mix for that frame. For example, if you enter 90% in the Out Mix field, 90% of the outgoing clip and 10% of the incoming clip are used in that frame. The In value is calculated based on the Out value (to make 100%).

To edit the mix percentage in any frame, use one of the following methods:

- Add and move control points on the mix percentage curve using the Add and Move options in the Edit Mode box.
- Display the frame that you want to edit and change the value in the Out Mix field.

NOTE Auto Key must be enabled.

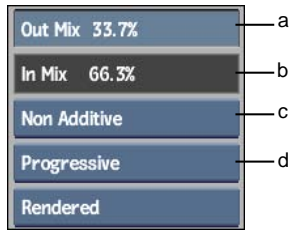

(a) Out Mix field (b) In Mix field (c) Dissolve Mode box (d) Render Type box

NOTE You can only add control points between the dissolve boundary keys (control points outside the boundary keys will not be processed). The boundary keys are located at the first and last frames in the dissolve. When you enter a new duration, the boundary keys are automatically updated.

- 5 Select processing in frames or fields from the Render Type box.
- 6 To load or save the mix curves, see [Saving, Loading, and Deleting Items](#) on page 802.
- 7 When you are satisfied with the results, click Exit.

Mixing Source Clips

You can generate a new clip from two source clips using the Mix menu. Each frame in the generated clip is the result of mixing an image in a frame of the first source clip with an image in the corresponding frame of the second source clip. You specify how the pixels of the source clips are combined to produce the corresponding pixels of the new clip.

To access the Mix menu:

- 1 Click Dissolve in the Editing menu.
- 2 Select Mix from the Dissolve Type box.
The Mix options appears.

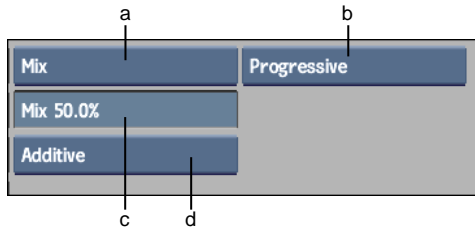

(a) Dissolve Type box (b) Render Type box (c) Mix Percentage field (d) Mix Mode box

Setting the Mix Percentage

The Mix Percentage value specifies how much of each clip will be used in the mix. For example, if the Mix Percentage is set to 80%, the resulting mix will contain 80% of the first source clip and 20% of the second source clip. If the Mix Percentage is set to 50%, the result clip will contain 50% of each source clip.



Action: Select the first source clip

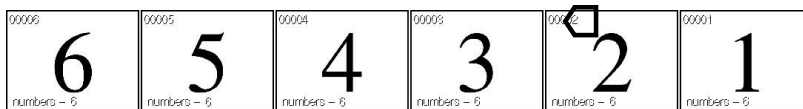

Action: Select the second source clip

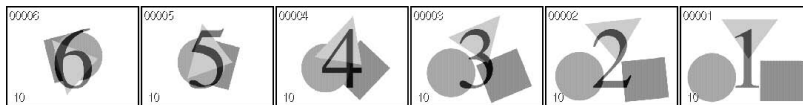

Result: The result clip contains 50% of each source clip

To create a clip that is a mix of two source clips:

- 1 Select Mix from the Dissolve Type box.
- 2 Enter a value in the Mix Percentage field.
- 3 From the Mix Mode box, select a mix mode.

- 4 Select the first source clip.
- 5 Select the second source clip.
- 6 Select the destination reel.
The mixed clip appears on the destination reel.

Modifying the Mix Percentage

You can modify the mix percentage across the length of the clip using the Mix Editor. For example, instead of having the same mix percentage across all frames in the clip, the mix percentage can be 50% in frames 1 through 5, 75% in frames 6 through 10, and 25% in frames 11 through 15.

To access the Mix Editor:

- 1 Select Mix from the Dissolve Type box.
An “E” (for Editor) appears on the Dissolve button.
- 2 Select the first and second source clips.
The “E” on the Dissolve button is highlighted.
- 3 Click Dissolve.
The “E” on the Dissolve button is highlighted.
- 4 Select a destination reel.
The Mix Editor appears.

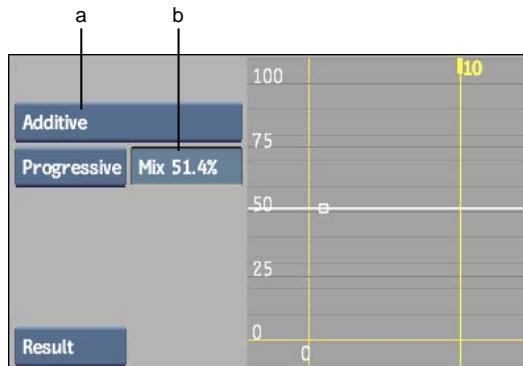

(a) Mix Mode box (b) Mix Percentage field

The graph plots the frame number (on the horizontal axis) against the mix percentage (on the vertical axis). The default curve is a straight line,

indicating that the mix percentage is the same (50%) in all frames of the clip.

To change the mix percentage in one or more frames of the clip:

- 1 Display the frame that you want to edit in the image window. This will allow you to see the result of changing the mix percentage value for that frame.
- 2 Select Add from the Edit Mode box.
- 3 Add a point on the curve for the frame that you want to edit.
- 4 Select Move from the Edit Mode box.
- 5 Move the new point up or down to the required mix percentage value.
- 6 Continue to add, move, or delete points on the curve until you achieve the required result.
- 7 Select processing in frames or fields from the Render Type box.
- 8 To load or save mix curves, see [Saving, Loading, and Deleting Items](#) on page 802.
- 9 Go to frame 1.
- 10 Click Process to process the clip. When you are finished editing and processing the clip, click Exit to return to the desktop reels.

Creating Dissolves on the Timeline

You can add dissolves to clips brought into the Player or Batch timeline. You use the Dissolve options to set the duration, mode, and other parameters of a dissolve. You can also access the Dissolve Editor from the timeline to modify the Mix Percentage curve.

You set default values for dissolves created on the timeline in the Timeline section of the Preferences menu. See [Dissolve](#) on page 845.

To create a dissolve on the timeline:

- 1 Do one of the following:
 - Bring the clip into the Player and click Timeline.
 - Bring the clip into Batch and click Timeline.

- 2 Select the cut or move the timeline positioner to the transition where you want to add the dissolve. Use the **B** and **N** hot keys to move between cuts.
- 3 Make sure there are enough heads and tails for the dissolve.
- 4 Click Dissolve or press **End**.



If the splice does not have sufficient handles to create a dissolve of the specified default duration, the dissolve will have the maximum duration possible.

- 5 Set the dissolve options.

Accessing the Dissolve Quick Menu

The dissolve options appear after you create a dissolve. The options are available from both the quick menu and the Dissolve Editor.

To access the Dissolve quick menu:

- 1 Select the dissolve on the timeline or place the positioner at the cut point.
- 2 Select Editing from the Menu Priority box.

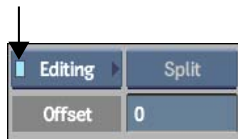

The Dissolve quick menu appears.

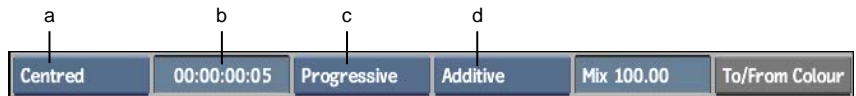

- (a) Dissolve Alignment box (b) Dissolve Duration field (c) Render Type box
(d) Dissolve Mode box

The Dissolve options are described as follows.

Dissolve Duration field Shows the present duration of the dissolve. Use this field to change the number of frames used in the dissolve.

Dissolve Mode box Affects how the pixels of the outgoing and incoming clips are combined to produce the corresponding pixels of the dissolve.

Select:	To:
Additive	Add the colour value of a pixel in the first source clip to the colour value of the corresponding pixel in the second source clip. This value is assigned to the pixel in the resulting dissolve.
NonAdd	Evaluate the corresponding pixels in the first and second source clips to determine which has the higher colour value. This value is assigned to the pixel in the resulting dissolve. Non-additive dissolves must be rendered in order to view them.
Inverse Non-Add	Evaluate the corresponding pixels in the outgoing and incoming source clips to determine which has the lower colour value. The pixel in the resulting dissolve is assigned the lower of the two values. Inverse non-additive dissolves must be rendered to view them.

Render Type box Specifies if the dissolve will be rendered as progressive or interlaced.

Dissolve Alignment box Specifies how the dissolve aligns with the cut.

Select:	To:
Up To Cut	Start the dissolve at the number of frames before the focus point that is specified by the dissolve duration. Thus, the dissolve ends at the focus point.
Centred	Centre the dissolve over the focus point with an equal number of dissolved frames before and after it. If the dissolve has an odd duration, the extra frame is always placed after the focus point.
From Cut	Start the dissolve at the focus point and have it proceed into the incoming clip by the number of frames indicated in the dissolve duration.
Custom	Create an asymmetric transition that can be offset from the cut point.

To/From Colour button Use to dissolve to or from a custom colour.

Creating a Dissolve on Multiple Timeline Tracks

You can create a dissolve on both audio and video tracks at the same cut point.

To create a dissolve on multiple tracks:

- 1 Make sure that a cut exists on all the tracks where you want the dissolve.

TIP To create a cut on all tracks, press **Shift+Del**.

- 2 Make sure that there are sufficient head and tails on all segments.
- 3 Place the positioner at the cut point by pressing **B** or **N**, or select all cut points.
- 4 Press **Shift+End** to create a dissolve on all the tracks.

Fading to Black or Fading from Black on the Timeline

You can create a fade from black (fade-in) by adding a dissolve at the beginning of the first segment on a track or at the beginning of a segment preceded by a gap. Likewise, you can create a fade to black (fade-out) at the end of the last segment on a track or at the end of a segment followed by a gap.

The following procedure shows how to create a fade from black. To create a fade to black, follow the same instructions but work at the end of the video clip instead of the beginning. Note that head and tail frames are not needed for fades, as the first frames of the segment are used.

To create a fade from black:

- 1 Move the positioner to the beginning of the timeline or to the beginning of a segment preceded by a gap.
- 2 Add a dissolve by pressing **End**.
A dissolve is added using the default duration. The alignment is set automatically to From Cut.
- 3 Adjust the dissolve duration, mix rate, and mode as needed.

Creating a Fade on Multiple Timeline Tracks

You can add a fade-in or fade-out to both video and audio tracks simultaneously on the timeline.

To create a fade on multiple tracks:

- 1 Place the positioner at the beginning or end of the Batch timeline.
- 2 Press **Shift+End**.
A fade-in or fade-out is created on each track.
- 3 Adjust the duration of the fade on each track as needed.

Accessing the Dissolve Editor

Use the Dissolve Editor to animate the blending effect of the dissolve over time. Dissolve curves are hermite by default. The Dissolve Editor is only available for video dissolves. You can access the Dissolve Editor from the Batch or Player timeline.

To access the Dissolve Editor:

- 1 Create a dissolve.
- 2 Click E beside the Dissolve button.
The Dissolve Editor appears.
- 3 Modify the dissolve curve to create a complex blending effect that changes over time. For information on using the Dissolve Editor, see [Animation](#) on page 1963.

Creating Wipes

Flame contains a number of predefined SMPTE wipe patterns. When creating a wipe, you can choose a wipe pattern from the file browser or enter the SMPTE pattern number in the Pattern Number field.

To add a SMPTE wipe:

- 1 Select the transition where you want to create the wipe.
- 2 Click Wipe.

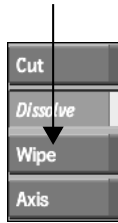

The wipe specified in the SMPTE Pattern Number field is added to the cut.



(a) Alignment box (b) Duration field (c) SMPTE Pattern Number field (d) Global Axis box

- 3 To change the wipe, click Pattern.

The file browser appears.

NOTE If you know the identification number of a specific SMPTE wipe, you can enter that number in the Pattern Number field to apply the wipe to the selected transition.

- 4 Select a pattern from the list of available SMPTE wipes. Selecting a pattern causes you to exit the file browser.
- 5 Select the alignment from the Alignment box.
- 6 Set the duration in the Duration field.

Adjusting the Global Axis of a SMPTE Wipe

After adding a wipe to the timeline, you can modify its position, rotation, scaling, and softness in its quick menu.

The global axis gives you control over all masks that are created for any given SMPTE wipe. If you create a wipe that requires two separate masks, you can adjust them both simultaneously in the viewport.

To adjust a wipe's global axis values from the Wipe quick menu:

- 1 Select the wipe icon on the timeline and display its quick menu.

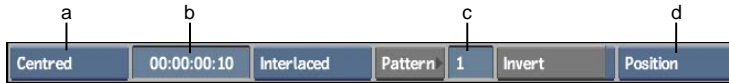

(a) Alignment box (b) Duration field (c) SMPTE Pattern Number field (d) Global Axis box

- 2 Select an option from the Global Axis box.

Select:	To adjust:
Position	The position of the SMPTE wipe.
Motion	The rotation of the SMPTE wipe.
Softness	The edge softness of the SMPTE wipe.
Options	The scaling and blending options of the SMPTE wipe.

Editing Wipes

If the preset SMPTE wipes do not offer enough flexibility, you can create customized wipes with the Wipe Editor. Starting from one or multiple garbage masks of any shape, create wipes that, for example, follow on-screen motion or mimic the shape of an object in a clip.

Use the Wipe Editor to:

- Create wipes that follow the motion of an object as it uncovers the incoming clip.
- Create wipes that resemble shapes in your frames.
- Create wipes that act as complex dissolves.
- Modify existing SMPTE wipes.

To create or modify a customized wipe:

- 1 Add a SMPTE wipe to a transition on the timeline.
- 2 Set the transition duration.
- 3 Set the alignment.

- 4 Select the SMPTE wipe icon on the timeline and then click E beside the Wipe button.

A garbage mask in the form of the SMPTE wipe pattern is displayed over the outgoing and incoming clips in the Wipe Editor.

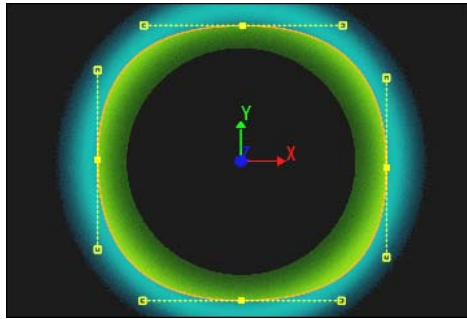

- 5 Modify the vertices of the garbage masks to change the wipe. See [Altering a Mask's Shape](#) on page 1088.
- 6 Click Exit Wipe to return to Batch.
- 7 Process the wipe.

Creating Customized Wipes with Garbage Masks

Use masks on the incoming clip to create a customized transition that wipes into the outgoing clip. Depending on the type of wipe you are creating, perform some or all of the following procedures:

- Set the mask drawing options. See [Setting the Mask Drawing Options](#) on page 1086.
- Draw the mask. See [Creating a Mask](#) on page 1086.
- Adjust the mask's shape. See [Altering a Mask's Shape](#) on page 1088.
- Set the mask effect. See [Controlling a Mask's Effect](#) on page 1088.
- Adjust the position, rotation, and scaling of the mask. See [Changing a Mask's Position, Rotation, and Scaling](#) on page 1091.
- Animate the mask parameters. See [Animating Masks](#) on page 1094. For more information about working with garbage masks, see [Garbage Masks](#) on page 1707.

Setting the Mask Drawing Options

Before you create a mask, set how the points of the mask are drawn.

To set the drawing options:

- 1 From the Wipe Editor, click Setup.
- 2 Specify the setup options.

Enable:	To:
Auto Tangents	Create tangents for every new point you set.
Show Border	View the border defined in the Offset field of the Shape menu. The colour pot next to the Show Border button defines the colour of the border.
Invert	Reverse your wipe. For instance, if you originally create an expanding box wipe, enabling Invert creates a shrinking box.
Spline Keyframing	Allow animation of points on the mask.

- 3 To change the colour of the mask's wireframe, colour points, or offset border, click a colour pot and pick a new colour.

Creating a Mask

Masks are controlled using the Wipe schematic. When you create a mask, an Axis node and Geom node are added to the schematic. The Axis node contains all the rotation, scaling, and position data, and the Geom node contains all the information about how the mask will affect the image (softness, opacity, alpha, axis offset).

To create a wipe mask:

- 1 From the Wipe Editor, click Mask.
- 2 Select Geometry from the Element box.

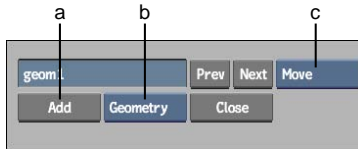

(a) Add button (b) Element box (c) Edit Mode box

- 3 Click Add, or select Create from the Edit Mode box.

TIP You may want to display the outgoing or incoming clip while drawing the mask since the composite is created in Result mode.

- 4 Click the image to create the first point.

NOTE If you are drawing a mask freehand, press **Shift** and then press down on the cursor to draw the mask. When you release the cursor, the mask closes automatically.

- 5 Click again to draw the second point.

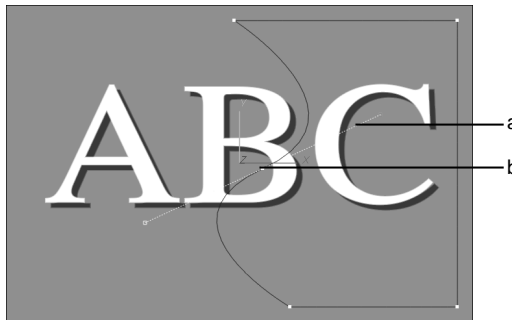

(a) Tangent (b) Vertex

NOTE If you are not in Auto Tangents mode, you can still create a tangent while setting a point by clicking and dragging the cursor.

- 6 To close the mask, click Close or click the first point.

Altering a Mask's Shape

You can manipulate points on a mask while displaying the incoming or outgoing clip.

Selecting Points

Select points using the Select option in the Edit Mode box. You can select individual points, individual tangents, or a group of points:

- To select a point or tangent, click it.
- To select additional points, press **Shift** and click the point. You can also press **Shift+Ctrl** and drag across a series of points.
- To select multiple points, press **Ctrl** and drag the selection box over a series of points.

Breaking Points

You can break or modify a tangent using the Break option in the Edit Mode box:

- Click a point to remove any tangents connected to that point.
- Click a tangent and hold down the cursor to edit it separately from its opposite tangent. You can also select the Move option to edit the tangent without editing its continuity. Click the tangent again and hold down the cursor to edit the continuity of the tangent. Click the tangent again and hold down the cursor to edit the continuity of both tangents.
- Click a point to remove any tangents connected to that point.

Calculating Tangents

Use the Auto option in the Edit Mode box to calculate the tangent for a point according to the curve the point is on. Select the Auto option and click a tangent.

Controlling a Mask's Effect

The Geom node contains all the information about how a mask affects the final transition. You can change this information in the Mask menu.

To control a mask's effect:

- 1 Select Matte or Result.
- 2 Select the mask in the image window.
- 3 Click Mask.
- 4 Set the mask opacity in the Opacity field.

The Opacity field defines the effect the mask has on the matte. A value of 100% means the inside of the mask is completely opaque. A value of 50% means the inside of the mask is 50% transparent. A value of 0% has no effect on the image.



(a) Colour and Opacity fields (b) Alpha and Offset fields (c) Axis Offset fields



Mask with 0% opacity



Mask with 100% opacity

- 5 Set the mask colour in the Colour field.

The Colour field defines the blend between the outgoing and incoming image inside the mask. A value of 50% is a 50/50 blend between the

outgoing and the incoming clip. A value of 100% displays only the outgoing clip. A value of 0% displays only the incoming clip.



Mask with 25% colour and 100% opacity



Mask with 75% colour and 100% opacity

- 6 Set the mask softness. See [Smoothing the Gradient of a Mask](#) on page 1090.
- 7 Set the axis offsets in the Axis Offset fields.
The Axis Offset fields defines how much a mask is offset from its axis.
- 8 Enable Outside if you want to apply the effect to the part of the image outside the mask shape.

Smoothing the Gradient of a Mask

You can adjust the softness gradient of a mask to smoothen the edges of your wipe. You can create a uniform gradient around the edge of the mask or use an advanced gradient to control the shape of the gradient at different parts of the mask.

To create a uniform gradient, you define how far you want the gradient to be offset from the edge of the mask and then set its transparency. To vary the shape of the gradient, you move vertices on inner and outer softness splines. The gradient will be based on how far each vertex point is offset from the mask.

For either type of gradient, you can smoothen the gradient towards the inside edge, the outside edge, as well as the area where the inside and outside adjustments have an effect.

To smoothen the gradient of a mask:

- 1 From the Wipe Editor, click Mask.

- 2 To create a uniform gradient around your mask, do the following:
 - If necessary, toggle the Advanced Gradient button to Softness.
 - Set the border of the softness gradient using the Offset field. Your gradient will be affected by how far the softness border is offset from the edge of the mask.
 - Set the transparency of the gradient using the Alpha field.
- 3 To change the shape of a gradient at different parts of the mask, do the following:
 - If necessary, toggle the Softness button to Advanced Gradient.
 - Adjust the distance of the inner and outer splines from the mask by adding and moving vertex points on the splines. If you do not see the inner and outer splines, enable Splines.
- 4 Use the Inner Edge field to smoothen the softness gradient towards the inside.
- 5 Use the Outer Edge field to smoothen the softness gradient towards the outside. Adjusting this value is especially noticeable if you are smoothening a transition from a black inside edge to a white outside edge.
- 6 Use the Distance field to modify the area over which the Inner and Outer Edge adjustments have an effect.

Changing a Mask's Position, Rotation, and Scaling

An Axis node contains all the rotation, scaling, and position data for the mask. You can change all this information in the Mask menu. The Axis controls are identical to those in the Action Axis menu. See [Action: Axis](#) on page 2169.

Tracking with Masks

You can track a point on your clip and apply that data to the axis of a piece of geometry or a hierarchy of objects. You can also track individual points on the mask. For information on tracking, see [Tracking and Stabilizing](#) on page 1781.

NOTE The points in the mask are not affected by the tracking data. The tracking data is applied to the entire mask.

To track the entire mask:

- 1 After creating a wipe, access the Wipe Editor and click Mask.
- 2 Select the wipe's mask axis.
- 3 Select Front or Back from the Layer box to specify whether you want to track on the outgoing clip (Front) or the incoming clip (Back).

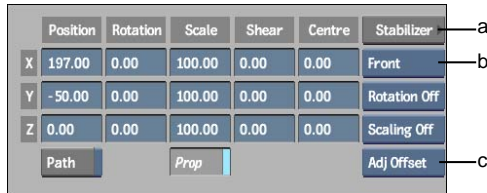

(a) S (Stabilizer) button (b) Layer box (c) Adjust option box

- 4 Select an option from the Adjust option box.
Select Adjust Offset if the selected mask is parented to one axis. Select Adjust Axis if the selected mask is parented to a hierarchy of objects.
- 5 Go to the first frame of the transition.
- 6 Click Stabilizer.
- 7 Set up the tracking point as needed.
- 8 Click Analyse.
Fine-tune your analysis if necessary.
- 9 Click Return.
The Wipe Editor reappears.

Tracking Individual Points on a Mask

You can also track individual points on a mask so that portions of the mask follow a point in the clip. Each point you select is assigned a tracker box in the Stabilizer. The points are repositioned according to the reference point you set in the Stabilizer. For more information on using the Stabilizer, see [Tracking and Stabilizing](#) on page 1781.

To track individual points on a mask:

- 1 After creating a wipe, access the Wipe Editor.

- 2 Select a vertex or a group of vertices on a wipe's mask.
- 3 Click Mask.

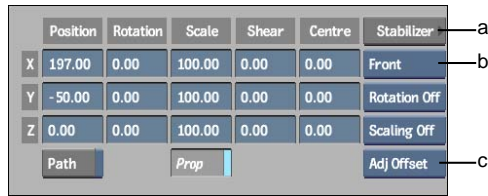

(a) S (Stabilizer) button (b) Layer box (c) Adjust option box

- 4 Select Front or Back from the Layer box to specify whether you want to track on the outgoing clip (Front) or the incoming clip (Back).
- 5 Select an option from the Adjust option box.
Select Adjust Tangents if you want the tangents for the selected points to be adjusted while the points are being tracked.
- 6 Go to the first frame of the transition.
- 7 Click Stabilizer.

The Stabilizer appears. A Tracker button appears for each selected vertex.

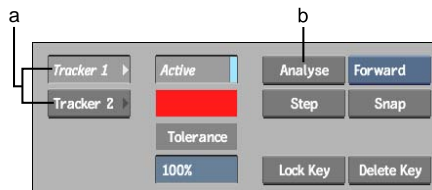

(a) Tracker buttons (b) Analyse button

- 8 Click Tracker 1, and then set up the first tracking point.
- 9 Click Tracker 2 to set up the second tracking point, and then continue setting up tracking points for all remaining vertices.
- 10 Click Analyse.
Fine-tune your analysis if necessary. For example, disable problem trackers and analyse again.
- 11 Click Return.
The Wipe Editor reappears.

12 Fine-tune your mask if necessary.

Animating Masks

You can animate the following mask properties:

- The characteristics of the camera in the scene
- The position, rotation, scaling, and shearing
- The mask shape
- The offset, border offset, border alpha, colour, and opacity

To display the Animation menu, click the Animation button.

Using the Wipe Schematic

The schematic uses nodes to represent the elements in the scene. The schematic also shows the relationship between a garbage mask and its axis.

Use the schematic, for example, to create new relationships between elements in complex animations.

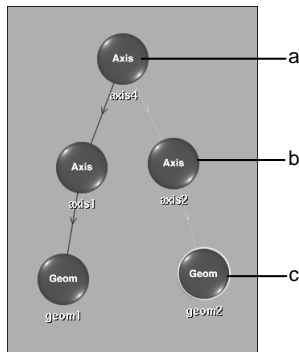

- (a) Axis4 is the parent of axis2 and geom2
- (b) Geom node represents a wipe mask
- (c) Axis for geom 2

To view the schematic:

- 1 Do one of the following:
 - Press **Esc**.

NOTE Pressing **Esc** a second time returns to the previous view.

- Select Schematic from the World View box.

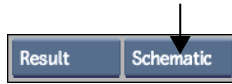

Nodes

In Schematic view, there is one node for each element in the scene.

Axis Nodes

Axis nodes are added to the scene when you create a garbage mask. These node types are used to control a mask's position, rotation, scaling, and shape, for example.

Geom Nodes

Geom nodes are added to the scene when you create a garbage mask. This type of node contains information about how the mask will affect the image (softness, opacity, alpha, and axis offset).

Adding Elements

You can add Axis nodes or Geom nodes.

To add an element to the wipe:

- 1 Select the type of element you want to add from the Element box.

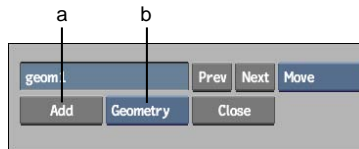

(a) Add button (b) Element box

You can add the following elements to the scene.

Select:	To add:
Geometry	A garbage mask to the scene.
Axis	An axis to the scene.

2 Click Add.

The element is added to the scene and a node representing the element is added to the schematic.

Selecting Elements

You must select an element before you can edit or animate it. Select an element in any of the following ways:

- Click the element in the scene.
- Go to Schematic view and click the node for the element.
- Display the Channel Editor and select the element's name or one of its channels.

You can also use the Prev and Next buttons to select the next or previous element.

Naming Elements

Each element you add to a wipe is automatically assigned a default name. The default name identifies the element and the order in which it was added. For example, axes are named axis1, axis2, axis3, and so on.

An element's name appears beneath its node in the schematic and as a folder in the Channel Editor. For example, if you add an axis to a wipe, its name appears both beneath the node in the schematic and in the Channel Editor.

You can assign more meaningful names to the elements using the Name field. If you rename an element, the schematic updates to show the new name. The element is also renamed in the Channel Editor.

To change the name of an element:

- 1 Select the element in the scene.
The current name for the element appears in the Name field.
- 2 Enter a new name in the Name field.

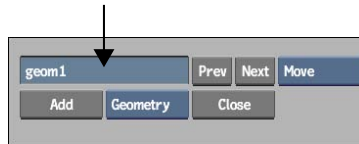

Modifying Elements in the Schematic

Select a mode from the Edit Mode box while in Schematic view to move, parent, unparent, or delete elements. The selected mode remains in effect until you select a different mode. The modes in this box may be used in other views in the Wipe Editor.

You can perform some types of edits in the schematic using hot keys regardless of the edit mode.

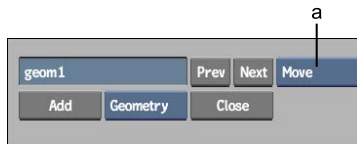

(a) Edit Mode box

Move Mode

Use Move mode to move nodes in the schematic. Moving nodes in Schematic view has no effect on the relationships between elements, nor does it affect the position of the elements in the scene.

To move a node in Schematic view:

- 1 Select Move in the Edit Mode box.
- 2 Click the node you want to move and drag it to a new position.
To move an element and its children, press and hold **Alt** while dragging the parent.

Deleting Elements

You can delete elements from an entire scene or just remove them from an existing branch.

To delete an element from an entire scene:

- 1 Do one of the following:
 - To maintain the links between other nodes in the branch, select the node and **Shift**-drag to the bottom of the screen.
 - To break the links between other nodes in the branch, select Delete in the Edit Mode box and click the node corresponding to the element you want to delete, or select the node and drag to the bottom of the screen.
The element is removed from the scene.

To remove an element from an existing branch:

- 1 Press **Ctrl+Alt** and drag the node away from the branch.
The node is removed from the branch but remains in the schematic.
Existing links between other nodes in the branch are maintained.

Parent and Cut Modes

There are two options in the Edit Mode box that you can use to change the relationship between nodes in the schematic:

- Use Parent to make one element the parent of another element.
- Use Cut to undo the parent/child relationship between two elements.

Copying Elements

Use the Copy button to copy an element or a branch (element and its children).

To copy a single element or branch:

- 1 Go to Schematic view.
- 2 Select the element you want to copy.
- 3 Select an option from the Selection box.

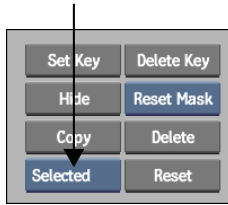

Select: **To:**

Selected Copy the currently selected element. For example, this option copies a geometry node without copying its parent axis, or an axis without copying its surface.

Branch Copy the selected element and all its children. To avoid copying elements by mistake, use the schematic to determine which elements you are copying.

NOTE The All Nodes option has no effect when copying. Use this option when hiding, deleting, or resetting elements.

4 Click Copy.

Hiding Elements

Use the Hide button to hide or unhide selected elements or branches. For example, when you are working on a specific surface, you may want to temporarily remove other elements from the scene without deleting them.

Hidden elements are marked “(hidden)” in Schematic view, and do not appear in the scene. For example, in the following *Before* schematic, both axis6 and

geom5 are shown in the scene. In the *After* schematic, geom5 is hidden and does not appear in the scene.



Before: geom5 is not hidden. It appears in the scene (below) as a wipe mask.

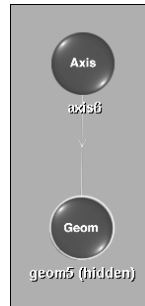

After: Geom5 is hidden. Its mask does not appear in the scene (below).



To hide a single element:

- 1 Go to Schematic view.
- 2 Select the element you want to hide.
- 3 Select Selected in the Selection box.
- 4 Click Hide.

To hide a branch:

- 1 Go to Schematic view.
- 2 Select the parent of the branch you want to hide.
- 3 Select Branch in the Selection box.

- 4 Click Hide.

To unhide an element or branch:

- 1 Select the hidden element or branch.
- 2 From the Selection box, select Branch if you are un hiding a branch or Selected if you are un hiding an element.
- 3 Click Hide.

Deleting Elements

Use the Delete button to delete elements from the scene.

To delete elements:

- 1 Select an option from the Selection box.

Select:	To delete:
Selected	The currently selected element. For example, this option deletes a geometry node without deleting its parent axis, or an axis without deleting its surface.
Branch	The selected element and all its children. To avoid deleting elements by mistake, use Schematic view to determine which elements you are deleting.
All Nodes	All elements in the scene.

- 2 Click Delete.

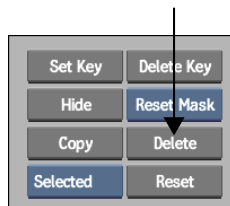

Creating Branches

With the Wipe Editor you can create complex animations where movements applied to one element are passed down to all connecting elements.

The relationship between elements is referred to as a *parent-to-child* relationship where the *parent* element passes its animations down to its child *element*. The structure of one parent and one or more child elements is referred to as a *branch*.

When you add certain elements to the scene, a parent-to-child relationship is created automatically. For example, when you add a surface to the scene, it is automatically parented by an axis.

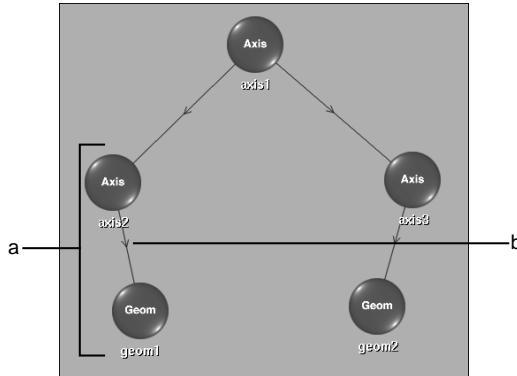

(a) When you add a wipe mask to the scene, an axis is automatically added and made the parent of the Geom node. (b) An arrowed line indicates that axis2 is the parent of geom1.

In the schematic, arrowed lines between elements indicate parent-to-child relationships.

NOTE You can use the Parent and Cut modes in Perspective, Top, Side, or Front view, but it is easier to use these modes in Schematic view.

Adding a Parent Axis

You can add an axis to the scene by itself, and then make it the parent of another element. Use this method of parenting additional axes to create complex wipes.

For example, you can create two masks that change shape and size independently but are parented to another axis translation in the same direction at a constant rate.

To create a branch:

- 1 Add an axis (axis2) to the scene.

- 2 In the World View box, select Schematic view. The Schematic view should be similar to the *Before* figure in step 4.
- 3 Select Parent in the Edit Mode box.
- 4 Drag the cursor from axis2 to axis1. Axis2 becomes the parent of axis1, as shown in the *After* figure.

TIP To add a node between two linked nodes, hold **Shift** and drag the node on top of the link. To link one node to another, select the node and **Shift**-drag so that it touches the other node. You can perform these actions regardless of the edit mode.

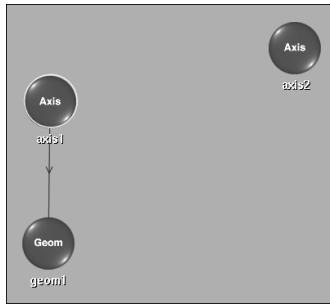

Before: The schematic shows axis1 as the parent of geom1.

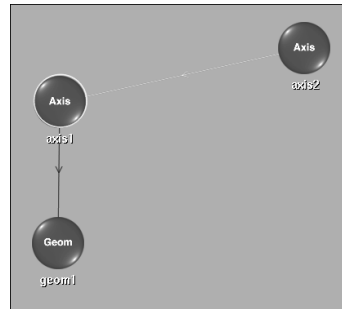

After: Axis2 is made the parent of Axis1 (and geom1) using Parent mode.

Any transformations applied to axis2 are applied to axis1 and its surface (image1). If axis1 has any transformations, they are added to the transformations from axis2. For example, if axis2 is set to 500, 100, 0 and axis1 is set to -50, 20, -30, the positions are accumulated and applied to the surface. In this case, image1 is positioned at 450, 120, -30.

Removing Branches

Use Cut or Parent mode to undo the relationship between elements.

To cut a parent-to-child relationship:

- 1 Select Cut or Parent in the Edit Mode box.

- 2 Go to Schematic view.
- 3 Drag the cursor across the arrowed line that joins the two nodes.
The connecting line is deleted, indicating that the relationship between the two nodes has been undone.

TIP You can also hold **Alt+Ctrl** and drag the object away from the link to remove an object between two linked nodes.

Using Templates for SMPTE Wipes

Templates are included with the preset SMPTE wipes that come with your application.

If you modify the start position or increase the duration for a SMPTE wipe, the interpolation for the transition may not be as even as it should be. For example, if you load a preset SMPTE pattern and change its default start position by a large number of frames, the transition may appear to jump at the last frame. Or, if you increase the duration of the transition by a large number of frames, the interpolation may also appear to jump between some frames. Use Adjust to fix this problem.

Adjusting a Preset SMPTE Wipe

If you modify the start position for the wipe, you can adjust the interpolation for the transition.

To adjust a preset SMPTE wipe:

- 1 Select the SMPTE wipe transition icon on the timeline and display its quick menu.



(a) Alignment box (b) Duration field (c) SMPTE Pattern Number field (d) Global Axis box

- 2 Click Pattern, and then select a wipe pattern in the file browser.
- 3 Move the positioner to the first frame of the transition.

- 4 Select Position from the Global Axis box, and then change the start position of the transition of the wipe using the X and Y Position fields. If you scrub the transition, you should see the wipe make a large jump at the last frame.
- 5 If the Adjust button is not greyed out, enable it.

NOTE If the Adjust button is greyed out, a template does not exist for the wipe and you must select a different pattern in order to use the Adjust feature.

The jump in the wipe should be gone and the interpolation for the wipe should be fairly even.

Adjusting a Custom Wipe

With custom wipes, you may need to create a template if:

- You intend to change the default start position for the wipe by using the X and Y Position fields in the Wipe quick menu.
- You intend to increase the duration of the transition by a large amount.
- You intend to use the custom wipe often.
- The custom wipe has no tracking data.

When you create a template, you must specify the default start position and then define an End Bias for all nine possible end positions. Once you create the template, you must enable the blue light on the Template button to make the Adjust option available.

To set the start position for a custom wipe:

- 1 Create your wipe. See [Creating Customized Wipes with Garbage Masks](#) on page 1085.
- 2 Select the transition on the timeline and click Pattern.
The file browser appears.
- 3 Select Custom in the SMPTE wipes box to view saved custom transitions.
- 4 Select the custom transition you want to use.
Your custom wipe is applied to the transition icon on the timeline.

- 5 Click E beside the Wipe button to enter the Wipe Editor.
- 6 Click Template to display the Template menu.
- 7 Enable the Template Mode button to view the template in the image window.

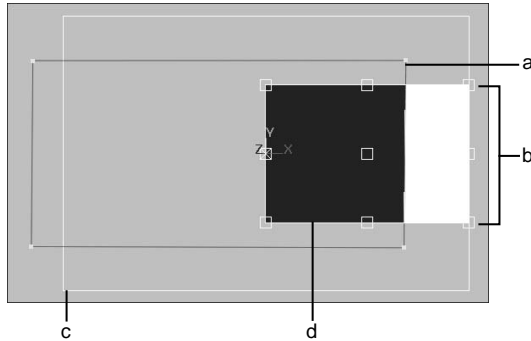

(a) Mask (b) Default start positions (c) Maximum Mask size box (d) Minimum Mask size box

- 8 Click Start Position.
- 9 Set the default start position by enabling a Start Position button, for example, Top Left.

To set the end bias for a transition:

- 1 Click End Bias.

The positioner goes to the last frame of the wipe.
- 2 Set the value in the currently enabled End Bias box to 0. (The currently enabled End Bias box should be the same as the default start position.)

On the last frame, the point closest to the centre of the axis should be just outside the image. This ensures that the mask fully covers the incoming image. If it does not, click the Mask button and proportionately increase the scale of the mask.
- 3 Set an End Bias for every End Bias position:
 - Click each End Bias box and drag the value until the mask is just large enough to encompass the entire image.

To adjust the custom wipe:

- 1 Enable Template.

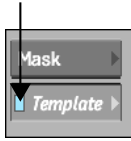

- 2 Exit the Wipe Editor.
- 3 Change the X and Y position for the wipe in the Wipe quick menu, or increase the duration of the transition.
- 4 Scrub the transition.
Notice how the interpolation causes the last frame of the wipe to jump.
- 5 Enable Adjust in the Wipe quick menu.
- 6 The interpolation of the transition should be much smoother.

Creating an Axis Transition

When you create an Axis transition, you modify the scaling, rotation, and position for the axis of one image to create the transition effect.

With an Axis transition, you can quickly swap the incoming and outgoing sources to reverse the animation. Swapping sources accommodates applications such as Apple® Final Cut Pro® and Avid® products, where the effect is applied to the outgoing source rather than the incoming one.

The Axis Transition menu is the same menu as the Axis Soft Effect menu, allowing you to add 3D text, and camera motion, as well as track any element within the image.

NOTE There is a palette of predefined Axis transitions located in `/usr/discreet/<product name>/setups_edm`. These setups fit the duration of the selected Axis transition.

To create an Axis transition:

- 1 Select a cut and then click Axis.
The Axis transition icon appears.
- 2 Display the Axis Transition quick menu and create the effect.

- 3 If you want more control over the transition, enter the Axis Editor by clicking E beside the Axis button. See [Creating Axis Soft Effects](#) on page 1122.

To reverse the animation using the swap source option:

- 1 Select a cut point between two video elements.
- 2 Apply a soft Axis transition.
- 3 Create the transition. For example:
 - At the first frame of the transition, set the Scale X and Y values to 0.
 - At the last frame of the transition, set the Scale X and Y values to 100.
- 4 Play the transition.

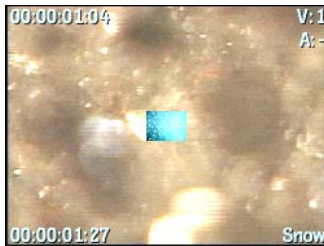

- 5 In the Axis Transition quick menu, enable Swap.



NOTE The Swap button in the Axis Transition Editor is called Swap Sources.

- 6 Play the transition again.
The incoming and outgoing sources are switched and the animation is reversed.

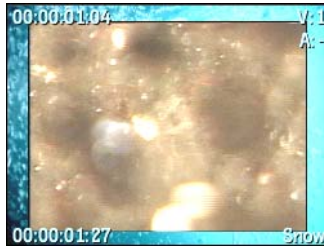

Copying Transitions

A transition can be copied to another cut on the Batch or Player timeline.

In Batch, the icon can also be lifted off the timeline and dragged to the Batch schematic. The resulting proxy can then be pasted onto a cut in the timeline.

To copy a transition using the Batch schematic:

- 1 Press **Alt+Shift** and drag the transition icon to the Batch schematic.
- 2 Set the clip where you want to copy the transition as the record clip and the dissolve in the schematic as the source clip.
- 3 Go to the cut in the record timeline where you want to copy the transition.
- 4 Press **I**.

To copy a transition to another cut on the timeline:

- 1 Press **Alt+Shift** and drag the icon to the other cut.

To remove a transition from the timeline:

- 1 Select the transition on the timeline.
- 2 Do one of the following:
 - Drag the icon off the timeline to the bottom of the screen and release the cursor.
 - Press **Delete** (or **Shift+Delete** for multiple tracks).

Topics in this chapter:

- [About Soft Effects](#) on page 1112
- [Processing Order of Soft Effects](#) on page 1112
- [Creating Soft Effects](#) on page 1115
- [Accessing the Soft Effect Editors](#) on page 1118
- [Creating Axis Soft Effects](#) on page 1122
- [Creating Wipe Soft Effects](#) on page 1132
- [Creating Sparks Soft Effects](#) on page 1133
- [Creating Colour Correction Soft Effects](#) on page 1134
- [Creating a Timewarp Soft Effect](#) on page 1135
- [Creating a Blend Soft Effect](#) on page 1136
- [Creating a Resize Soft Effect](#) on page 1137
- [Creating a Text Soft Effect](#) on page 1138
- [Trimming Animated Soft Effects](#) on page 1144
- [Creating Gap Effects](#) on page 1145
- [Linking Soft Effects](#) on page 1149
- [Copying Soft Effects](#) on page 1149
- [Muting Soft Effects](#) on page 1150
- [Deleting Soft Effects](#) on page 1151

About Soft Effects

Soft effects bring the power of the Flame effects module to the timeline. Unlike module effects, soft effects accelerate the creation and tweaking of effects because you apply the effect directly to the timeline. You can create soft effects on the Batch timeline as well as bring them in from Smoke. With the support of soft effects in Batch, clips are more compatible between products.

You apply soft effects to video and audio elements. You can also apply them to gaps in the timeline, including empty layers. Gap effects allow you to create an effect that spans more than one element.

If proxies have been enabled for your project, you can switch between full resolution and proxy mode in both the soft effects quick menus and the editors. Working with proxies speeds up processing time in projects with high-resolution images

If an interface element is not described in this chapter, refer to the corresponding effect in the module chapter. For information on audio soft effects, see [Working with Audio in the Timeline](#) on page 1204.

Processing Order of Soft Effects

Soft effects have a fixed pipeline. Regardless of the order in which you create them, they are always processed in the same order, from Text to Axis:

- Text
- Resize
- Blend
- Timewarp
- CC
- Sparks
- Wipe
- Axis

NOTE Not all soft effects can be added to a segment at the same time. For example, if you add an Axis soft effect to a segment with a Resize soft effect, the Resize effect is muted.

If you add both a Text and CC soft effect to the timeline, the soft Text is always affected by the soft CC regardless of the order in which they are added to the pipeline. An Axis soft effect is always processed last so it is not affected by other soft effects in the pipeline. This is illustrated in the following example.

First a Text soft effect is added to a segment.

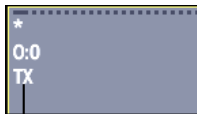

a
(a) Text soft effect indicator

Image courtesy of Technicolor (formerly Toybox)

Next a CC and Axis soft effect are added. The indicators are added to the timeline in the order in which the soft effects are processed. Because the soft Text is processed first, it is affected by both the soft CC and the soft Axis.

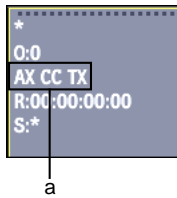

(a) Soft effect indicators listed in processing order
Image courtesy of Technicolor (formerly Toybox)

If you enter a BFX level and extract the soft effects, they are converted to nodes in the following order to maintain the same visual result.

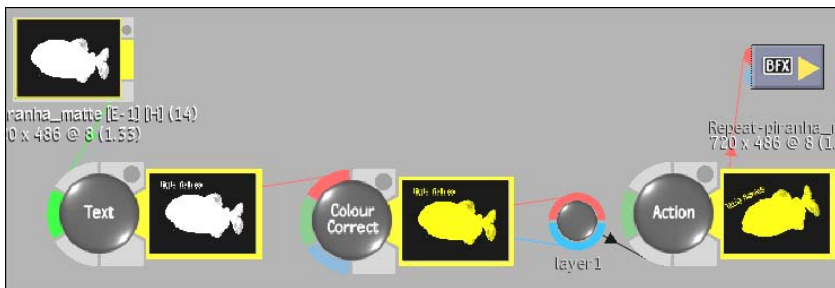

Because the BFX pipeline is not fixed, you have the flexibility of reordering nodes. In the following example, the Text and CC nodes are reordered. Because the CC node is processed first in the pipeline, the Text node is not affected by the CC node. For more information, see [Batch FX](#) on page 1375.

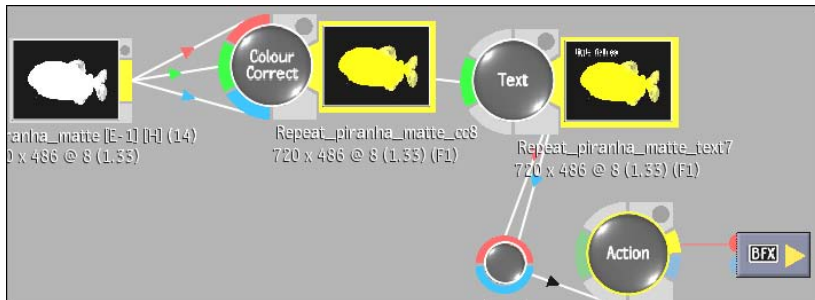

Image courtesy of Technicolor (formerly Toybox)

Creating Soft Effects

You apply soft effects to segments directly on a Batch timeline. You can apply soft effects to a clip either before or after Batch FX have been applied.

You create soft effects using either a soft effects quick menu or an editor. The quick menu provides access to the basic controls for each soft effect. For greater control and customization, use the editor.

To create a soft effect:

- 1 Display the Batch timeline of the segment where you want to add a soft effect.
- 2 Click the button for the soft effect you want to apply.

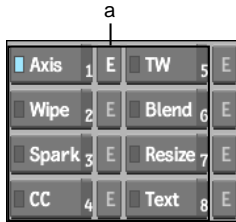

(a) Soft Effect buttons

Click:	To:
Axis	Work with the 3D X, Y, Z axis of layers and surfaces; create garbage masks, light sources, motion tracking, and 3D text. Also create chromo or self keys. See Creating Axis Soft Effects on page 1122.
Wipe	Add wipe effects to layers. The incoming and outgoing shots exist on different layers of the timeline. See Creating Wipe Soft Effects on page 1132.
Spark	Apply video Sparks to an element on the timeline. See Creating Sparks Soft Effects on page 1133.
CC	Perform colour correction and colour warping to elements directly on the timeline, which are animatable on a segment basis. See Creating Colour Correction Soft Effects on page 1134.
TW	Apply a timewarp to a clip on the timeline. See Creating a Timewarp Soft Effect on page 1135.
Blend	Control the transparency of a segment, which enables parts of the background to be exposed through overall transparency. The blend occurs between different layers of the timeline. See Creating a Blend Soft Effect on page 1136.
Resize	Edit a segment that was resized to fit the timeline resolution. Use Resize to correct blanking problems and add a soft letterbox. See Creating a Resize Soft Effect on page 1137.
Text	Add text to a video element. See Creating a Text Soft Effect on page 1138.

The soft effect quick menu is displayed, the LED on the soft effect button turns blue, and the soft effect indicator appears on the timeline segment.

NOTE If you do not see the quick menu, select and enable Editing in the Menu Priority box.

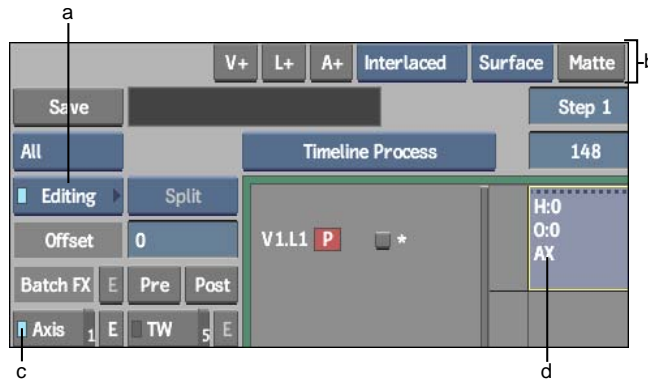

(a) Menu Priority box (b) Axis quick menu (c) Axis LED (d) Axis soft effect indicator

- 3 For more control of the soft effect, use the soft effect editor. See [Accessing the Soft Effect Editors](#) on page 1118.

Editing with Soft Effect Quick Menus

Access basic setups for a soft effect through its quick menu. If you applied the same soft effect to multiple elements, any changes you make to one element using the quick menu are applied to the other elements, as long as the elements are selected.

To reset quick menu values:

- 1 Click the name of the field or **Ctrl**-click inside a field.

To determine how soft effects are applied from the quick menu:

- 1 Select from the following options.

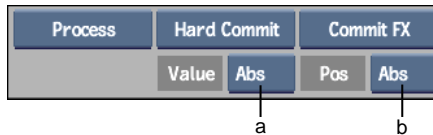

(a) Value box (b) Position box

Select:	To apply:
Value Abs	A value directly to all soft effects.
Value Rel	A relative change from the previous value. The change will apply to all soft effects.
Pos Abs	The change on all soft effects at the current position of the positioner.
Pos Rel	A change on all soft effects. The change is the frame difference from the start of the selected effect and the positioner. For example, if the positioner is at frame 10, all Resize soft effects will have a keyframe applied at frame 10.
Pos Prop	A change on all soft effects. The change is the proportional frame difference from the selected effect start and the positioner. For example, if the positioner is in the middle of the soft effect, all Resize soft effects will have a keyframe applied in their middle.

Accessing the Soft Effect Editors

Use the editors for greater control of soft effects. Soft effect editors are similar to those found in the full modules. For example, the Axis Editor is similar to Action but allows control of only one layer at a time.

For Axis, Sparks, and Resize, you must process the effect to see the final result in real time.

You can access a soft effect editor only after the corresponding soft effect has been applied to an element.

To access a soft effect editor:

- 1 Select an element on the timeline that has a soft effect applied to it.

- 2 Do one of the following:
 - Double-click the timeline element.
 - Click the Editor button (E) for the soft effect you want to modify.



Previewing in Soft Effect Editors

Within most soft effect editors, you can immediately see changes to the current frame by previewing your soft effects. Preview FX mode is useful if you have many unrendered soft effects or complex vertical edits that cause frames to be dropped during playback.

Most soft effect editors also provide a Context view so you can monitor the soft effect in the context of other timeline layers. With Context view, you are not restricted to monitoring layers at or below the current soft effect only. The focus point of the timeline positioner determines what layers are taken into account.

To use a soft effect editor's Context view:

- 1 Apply a soft effect to a timeline layer and then move the positioner's focus point to the topmost layer that you want to view from the editor.

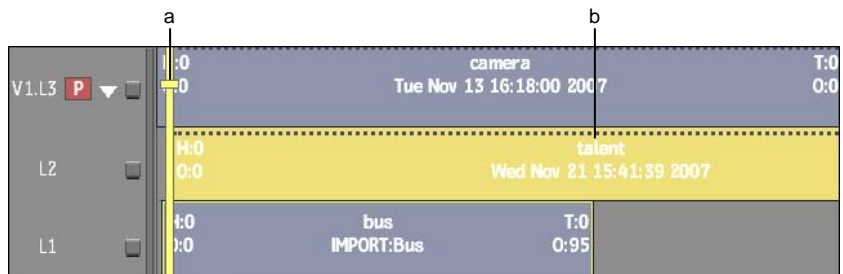

(a) Focus point (b) Layer with soft effect

- 2 Double-click the layer with the soft effect to access the soft effect editor. The following example displays the results of Preview FX mode, You see the output of L2 and L1. You do not see L3.



Image courtesy of Casablanca, Behavior Communications Inc.

- 3 From the soft effect editor, select Context from the Preview Options box.

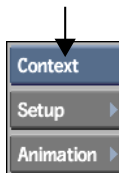

NOTE From the Blend, Timewarp, and CC editors in Batch, select Context from the View box in the lower-left corner. For Resize, enable the Context button.

All timeline layers, as indicated by the focus point of the timeline positioner, are displayed. In the following example, you now see the output of L3.



Image courtesy of Casablanca, Behavior Communications Inc.

TIP If you are in the Axis Editor, Context view disables the display of axis icons and control points, along with the ability to work with them gesturally. You can toggle between Preview FX and Context views to get the advantages of Context view without losing the interactivity with objects.

To preview a soft effect:

- 1 Select Preview FX from the Preview Options box.

Generating Clip Proxies

If proxies are set for your project, you can toggle between Proxies and Full Res mode from the soft effect editors.

You set proxies either when you create a project or from the Preference menu if you are in an existing project.

To generate clip proxies from soft effect editors:

- 1 From a soft effect editor, select Proxies from the Playback Resolution box, or press **Ctrl+P**.

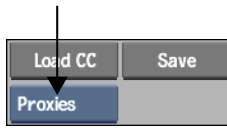

NOTE If the box does not appear, either proxies are not set for the project or proxies are set to conditional and there are none.

- 2 Toggle between Proxies and Full Res to view your results as you work.

Creating Axis Soft Effects

Use a soft Axis to create a single-layer effect directly on the timeline. For example, scale an element with a soft Axis to reveal an element on another layer. Adding a soft Axis to a soft Resize will mute the soft Resize.

To create a soft Axis:

- 1 Select an element on the timeline.
- 2 Move the focus point over the layer you want to use as the top of the vertical edit.
- 3 Click the Axis soft effect button.

The Axis quick menu appears.



(a) Rendering options (b) Layer Selection box

- 4 Set rendering options. You can set these options for both the result and the current clip. See [Axis Rendering Options](#) on page 1130.
- 5 To define surface attributes, select Surface from the Layer Selection box and then set the softness, position, scaling, and rotation for the surface.

- 6 To add a matte, select Surface or Matte from the Layer Selection box, click Matte and load a matte.

NOTE To temporarily turn off a matte as you work, select Matte from the Layer Selection box and then Off from the Matte box.

- 7 To add a shadow, select Shadow from the Layer Selection box, select On, and then set the position, scaling, and rotation for the shadow.

Creating Matte Containers

Containers are a convenient way to group elements on the timeline. The elements, which can come from different layers, can be edited as a unit yet remain individually editable. A matte container is a container with the RGB portion of an image on one track and its matte on another. If the matte for a clip exists separately from it, you can add the clip and its matte to the timeline as a single element by creating a matte container for them.

For single-frame mattes and virtual sources, there are special considerations. If the matte consists of a single frame, it is automatically repeated to match the duration of the front clip. If both the front and matte clips are virtual sources, the matte container is created as a virtual source. You can trim, slip or slide it to any extent.

You can create a matte container in the following ways:

- Using the Axis soft effect quick menu or editor.
- By importing the RGBA file directly into a matte container. See [Importing RGBA Files](#) on page 220. (This option does not repeat single-frame mattes to match the front clip.)

You can mute a matte from the timeline or from the Axis Editor.

NOTE For more information on containers, see [Working with Containers](#) on page 1041.

To create a matte container using the quick menu:

- 1 Load your fill to the timeline.
- 2 Select the fill on the timeline and apply a soft Axis.
- 3 In the quick menu, click Matte.

- 4 Select your external matte from the Desktop.

NOTE You cannot use a timeline element as your matte selection.

A matte container is created.

To create a matte container using the editor:

- 1 Load your fill to the timeline.
- 2 Select the fill on the timeline and apply a soft Axis.
- 3 Enter the Axis Editor.
- 4 Click Load Matte.

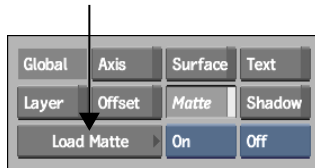

- 5 Select your external matte from the Desktop.

NOTE You cannot use a timeline element as your matte selection.

The matte container is created.

To enter a matte container:

- 1 Double-click the matte container or click E beside the Container button. The matte container contains two tracks: your fill on V1 and the external matte you selected on V2. You edit the contents of a matte container the same way as a normal container.

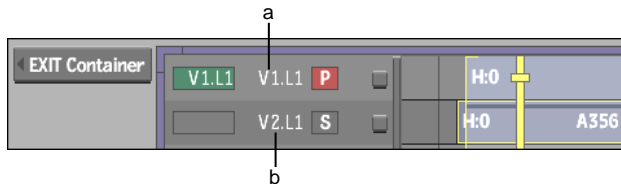

(a) Fill on V1 (b) External matte on V2

To mute a matte from the Axis Editor:

- 1 Select the matte container.
- 2 Enter the Axis Editor.
- 3 Select Off from the Matte box.
The matte is temporarily removed from the vertical edit.

To mute a matte from the timeline:

- 1 Click the Container button.
The LED turns yellow.

NOTE To unhide the matte, click the Container LED button so that it turns purple.

Axis Editor

Use the Axis Editor to create effects that include 3D text, motion tracking, and keyed components. The Axis Editor is similar to Action. However, you can only manipulate a single layer, and you cannot apply textures to 3D text.

This section discusses components specific to Axis soft effects. For complete information on menus and controls, see one of the Action chapters in this guide.

Settings defined in the Axis quick menu and Axis Editor are carried over to each other. For example, if you set Matte to On in the quick menu, it is set to On in the Axis Editor.

To use the Axis Editor:

- 1 Add a soft Axis to the element.
- 2 Double-click the element or click E beside the soft effect button.
The Axis Editor appears.

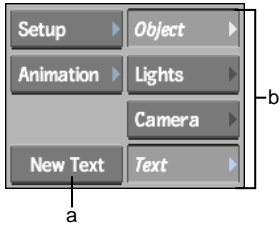

(a) New Text button (b) Axis menu buttons

3 Access any of the following Axis menus.

Menu	Description
Object	The Object attributes are similar to the corresponding attributes in Action. However, you cannot load additional layers from the editor; you can only transform the clip that has the Axis soft effect. As well, there is no 3D displacement.
Lights	The Lights attributes are identical to the corresponding attributes in Action. However, you only have access to one light from the editor.
Camera	The Camera attributes are identical to the corresponding attributes in Action. However, you only have access to one camera from the editor.
New Text	The Text attributes are identical to the corresponding attributes in Action with the exception of texture controls. To display the Text menu button, click the New Text button.

Working with Axis Soft Effect Layers

Working with global and axis transitions is different in the Axis Editor than in Action. Only one layer is available with the Axis soft effect.

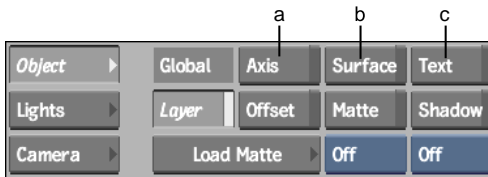

(a) Axis button (b) Surface button (c) Text button

To work with a specific axis:

- 1 Click Object.
- 2 Select the axis you want to modify, or click Surface, Text, or Axis.



(a) Text axis (b) Global axis (controls each axis in the scene) (c) Surface axis

- 3 Modify the attributes of the selected axis. You can modify attributes using the respective fields or select an option from the Edit Mode box and work directly in the image window.

To work with the layer:

- 1 Click Object.
- 2 Click Layer.
- 3 Click the border of the layer to select it.
- 4 Modify the layer attributes, You can modify attributes using the respective fields or select an option from the Edit Mode box and work directly in the image window.

Hiding Nodes

You can hide the current axis. For example, enter the Axis Editor with a black source and add 3D text. Then hide the black source so that the only element used in the soft effect is the 3D text.

To hide a node:

- 1 Select an element on the timeline.
- 2 Apply a soft Axis and enter the Axis Editor.
- 3 Click New Text.
- 4 Type a text string and click Enter.
- 5 Click Create.
- 6 Select the image by clicking its border.
- 7 Click Hide Node.

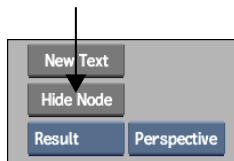

The image is hidden, and only the 3D text remains.

Axis Keyer

You can create chroma keys directly on the timeline using the Axis Keyer. When you enter the Axis Keyer, the clip loaded as the Front is the clip with the Axis soft effect, and the clip loaded as the Back is the next available layer on the timeline.

To use the Axis Keyer:

- 1 Build a multilayer timeline with a front layer and background.
- 2 Select the layer you want to key, and click Axis.
- 3 Double-click the element or click E beside the soft effect button.
- 4 In the Object menu, click Keyer.

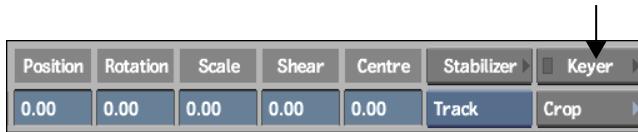

The Axis Keyer appears.

The Front clip is provided by the clip with the Axis soft effect, and the Back is provided from the next available clip in the multilayer timeline.

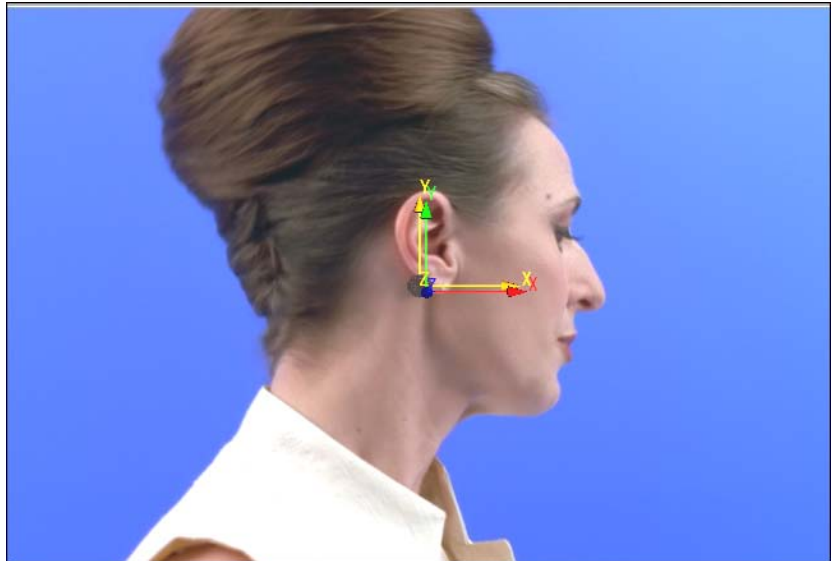

Image courtesy of Behavior Communications Inc.

- 5 Create the key. See [Keyer](#) on page 1545.



Image courtesy of Behavior Communications Inc.

Axis Rendering Options

When rendering a soft Axis, you can specify some render options for the image and others for surfaces in the Axis effect such as 3D text elements. You set these options from the Axis quick menu or from the Axis Editor.

To set the rendering options from the quick menu:

- 1 Select one of the following rendering options.

Select:	To render:
Interlaced	The surface and 3D text elements in fields.
Progressive	The surface and 3D text elements in frames.

To set the rendering options from the Axis Editor:

- 1 Click Setup.
- 2 Select one of the following rendering options.

Select:	To render:
Interlaced	The image in fields.
Progressive	The image in frames.

NOTE Each Axis soft effect can have its own rendering option.

Wireframe Mode

Use the Wireframe option in the Setup menu and in the Object menu to display a wireframe preview of your setup. You can also render a soft Axis in wireframe mode.

To render in wireframe mode:

- 1 Enter the Axis Editor.
- 2 Do one of the following:
 - To view only the image in wireframe mode, click Object and enable Wireframe.

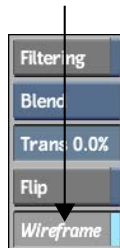

- To view the entire scene, including 3D text in wireframe mode, click Setup and enable Wireframe.
- 3 In the Setup menu, set the Resolution value for the wireframe.
 - 4 Click Process.

Creating Wipe Soft Effects

Use the Wipe soft effect to create a vertical wipe between layers on the timeline. For more control of the Wipe soft effect, use the Wipe Editor.

To create a Wipe soft effect:

- 1 Select the element you want to use as the incoming shot of the vertical wipe.
- 2 Set the focus layer by moving the focus point over the layer you want to use as the top of the vertical edit.
- 3 Click the Wipe soft effect button.
The Wipe quick menu appears.



(a) Pattern selection (b) Wipe options

- 4 Enter the wipe pattern number, or click Pattern and select an SMPTE wipe from the SMPTE wipe library.
- 5 Specify the wipe attributes for each option.

Select:	To adjust:
Position	The position of the SMPTE wipe.
Motion	The spin factor of the SMPTE wipe.
Softness	The edge softness of the SMPTE wipe.
Options	The scaling and blending options of the SMPTE wipe.

- 6 To access the Wipe Editor, double-click the element or click E beside the Wipe soft effect button. Edit the wipe as you would SMPTE wipe transitions. See [Editing Wipes](#) on page 1084.

Creating Sparks Soft Effects

Use the Sparks soft effect to apply video Sparks to video elements on the timeline. Sparks soft effects are applied below Axis and Wipe effects. If you want to apply a Sparks effect to an element that contains an Axis or a Wipe effect, you need to contain it first if the result of the Axis or Wipe effect is required by the Sparks. Or, you can apply the Sparks soft effect to a gap above the element containing an Axis or a Wipe effect.

You can use Sparks that require up to four inputs, but you cannot use desktop Sparks. With desktop Sparks, you do not enter a module to create the effect. For example, the SparkBroadcast Sparks that is shipped with the system does not have an editor. It applies the effect directly to a clip you select on the Desktop and therefore cannot be used as a Sparks soft effect.

To use a Sparks soft effect:

- 1 Select the element to which you want to apply the Sparks soft effect.
- 2 If the Sparks you are using requires a matte, click Matte in the Spark quick menu and load the matte.
A matte container is created.
- 3 Click the Spark button and load your Sparks.

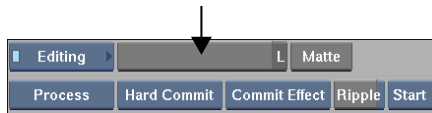

TIP To change a currently loaded Sparks, hold **Alt** when you click the Spark button.

- 4 Set the input for each layer.
- 5 Click the Spark button again, or the E button next to the Spark, to enter the Spark Editor.

Preview FX in the Spark Editor

The Preview FX option works the same in the Spark Editor as in every other editor and on the timeline. However, if the element to which you are applying the Sparks also has an Axis or a Wipe effect, you will not see the result of the Axis or Wipe effect in the Sparks module while using Preview FX because these

soft effects are upstream of the Sparks effect. If you want to preview all effects, you must exit the Spark Editor and use the Preview FX option in the Player.

Creating Colour Correction Soft Effects

Use the Colour Correction soft effect to add colour corrections to elements directly on the timeline. You can also colour correct segments on the timeline using the Colour Warper™ tool

To create a Colour Correction soft effect:

- 1 Select the element to which you want to apply the colour correction.
- 2 Click the CC soft effect button.
The Colour Correction quick menu appears.
- 3 Modify any of the values for contrast, offset, gain, saturation, or hue.
- 4 To display the Colour Warper quick menu, click CC.

Colour Correction Editor

If you want more control over the Colour Correction soft effect, use the Colour Correction Editor. The Colour Correction Editor is similar to the standard Colour Corrector; however, it does not accept a matte, background, or reference buffer. Only components specific to the Colour Correction soft effect are explained in this section.

To access the Colour Correction Editor:

- 1 Add a Colour Correction soft effect to the element.
- 2 Double-click the element or click E beside the soft effect button.
The Colour Correction Editor appears.

Creating Colour Warper Soft Effect

Use the Colour Warper soft effect to colour correct elements directly on the timeline.

You can apply colour corrections with the Colour Warper tool from the Colour Correction quick menu or the Colour Correction Editor. Access the Colour

Warper from the Colour Correction quick menu to make basic colour corrections. Access the Colour Warper from the Colour Correction Editor for more control over the Colour Correction soft effect.

With the soft effect preferences, you can also define which colour correction tool (Colour Corrector or Colour Warper) is applied by default. See [Colour Corrector](#) on page 1451.

To access the Colour Warper from the Colour Correction quick menu:

- 1 Select the element to which you want to apply the colour correction.
- 2 Click the CC soft effect button.
- 3 Click CC.
The Colour Warper quick menu appears.
- 4 Modify the values for black level, white level, hue, saturation, and gamma.

To access the Colour Warper soft effect from the Colour Correction Editor:

- 1 Select the element to which you want to apply the colour correction.
- 2 Click the CC soft effect button.
- 3 Double-click the element or click E beside the soft effect button.
The Colour Correction Editor appears.
- 4 Click CC.
The Colour Warper editor appears. In the Preferences menu, you can specify whether the Colour Corrector or the Colour Warper editor is shown by default in the Colour Corrector soft effect menu. Once a Colour Correction soft effect is applied, the selected menu will appear in the editor.
Use the Basics, Selective, and Subsetups menus to apply colour corrections to the selected element. See [Colour Warper](#) on page 1483.

Creating a Timewarp Soft Effect

If you edit a clip to the Batch timeline so that the overall duration of the timeline does not change, a Timewarp soft effect is automatically created. You can change the timewarp settings with the Timewarp Editor. You can also apply a Timewarp soft effect to create effects that change the speed or direction of a clip.

NOTE To have timewarps automatically created when the framerate of the clip you are adding to the timeline is different from the framerate of the timeline, enable Framerate Converter in the Timewarp section of the Timeline Preferences menu.

To create a Timewarp soft effect:

- 1 Select the segment to which you want to apply a Timewarp soft effect.
- 2 Click the TW soft effect button.
The TW quick menu appears.
- 3 Set the properties for the timewarp. See [Timewarps](#) on page 1153

Creating a Blend Soft Effect

Use Blend soft effects to adjust the transparency between layers on the timeline. Blend soft effects are similar to dissolve transitions except that the Blend soft effect occurs vertically across layers.

With Blend soft effects, intermediate clips are created. If you add a dissolve to a clip that has a Blend soft effect, the result of the blend will be used as the incoming source.

For more control of the Blend soft effect, use the Blend Editor. You can modify the shape of the blend curve for complex results.

To create a Blend soft effect:

- 1 Select the element you want to use as the incoming shot of the vertical blend.
- 2 Set the focus layer by moving the focus point over the layer you want to use as the top of the vertical edit.
- 3 Click the Blend soft effect button.
The Blend quick menu appears.
- 4 Select a Blend mode.

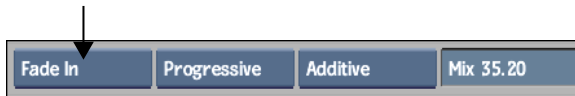

Select:	To:
Fade In	Create a mix curve that starts at 100% at the first frame and ends at 0% at the end of the clip.
Constant	Create a constant mix value of 50% for the length of the blend.
Fade In/Out	Fade in to the incoming clip for the first 0.5 seconds and fade out for the last 0.5 seconds. Clips shorter than 1 second fade in for the first 25% of the clip, and fade out for the last 25% of the clip.
Fade Out	Create a mix curve that starts at 0% at the first frame and ends at 100% at the end of the clip.

- 5 Set the rendering and mix options.
- 6 To access the Blend Editor, double-click the element or click E beside the Blend soft effect button. Modify the animation channel for the Mix value until you get the desired result. See [Creating Dissolves on the Timeline](#) on page 1078.

Creating a Resize Soft Effect

If you edit two clips of different resolutions together on the timeline, a Resize soft effect is automatically created.

You can also apply a Resize soft effect directly to a segment to create effects such as a letterbox or to animate image position.

To create a Resize soft effect:

- 1 Select the segment that you want to resize.
- 2 Click the Resize soft effect button.
The Resize quick menu appears. Set the resize settings. See [Resize](#) on page 663.

Soft Resize Editor

The Soft Resize Editor has a two-Player display: source resolution (left) and destination resolution (right). This interface layout is useful for performing pan and scan. Press **Ctrl+Alt+M** on either Player to lock the view on the broadcast monitor. Using the lock feature can let a client monitor the final framing while you continue working on the source image.

Creating a Text Soft Effect

Text soft effects are an easy, flexible way to add graphics to the timeline. Most Text soft effects can be previewed in real time. You can add several, stacked Text soft effects to a timeline without significantly affecting performance. Text soft effects differ from the regular Text module in a few ways. Soft Text includes:

- The ability to create a text layer with or without a matte
- The ability to create a matte key
- The ability to add text to a gap effect. See [Adding Soft Text to an Empty Layer](#) on page 1147.

NOTE Soft Text does not include logos. To work with logos, use the regular Text module.

You can also import XML files containing subtitles to a timeline, and edit attributes such as colour and font directly in the XML file. See [Importing Subtitle XML](#) on page 465.

For information on Text settings that are also available from the Text module, see [Text](#) on page 1909.

Accessing Soft Text Controls

Use the Text editor to create text. Use the Text quick menu for making minor changes.

To access the Soft Text quick menu:

- 1 Select an element on the timeline and then click the Text soft effect button.

- 2 Select an option from the Soft Text Quick Menu box.



Select:	To access controls for:
Basic	Changing text attributes such as font size, and to determine whether a matte is created.
Layer Axis	Changing the orientation of the text layer. If you are working in proxy mode, the values correspond to the proxy.
Fill/Under	Changing the fill or underline attributes for the text.
Out/Shad	Changing the outline and shadow of the text.

- 3 To access the soft Text editor, double-click the element or click E beside the soft effect button.

Creating Text Layers

You can create a text layer with or without a matte. A text layer with a matte can be used to place a layer of text on a background. Create text layers with mattes when you are planning to use the text with a soft effect that requires a matte to composite a foreground on a background. You use the composited text as an input for Sparks or when adding an axis.

The transparency of the text's fill attribute receives special treatment when creating a text layer with a matte. By default, the transparency value is transferred to the matte. In the composite, this yields an image in which the text has the expected transparency.

To create a text layer:

- 1 Add a Text soft effect to a front layer on the timeline.
- 2 Add a background layer to the timeline.
- 3 Create text in the Soft Text editor.

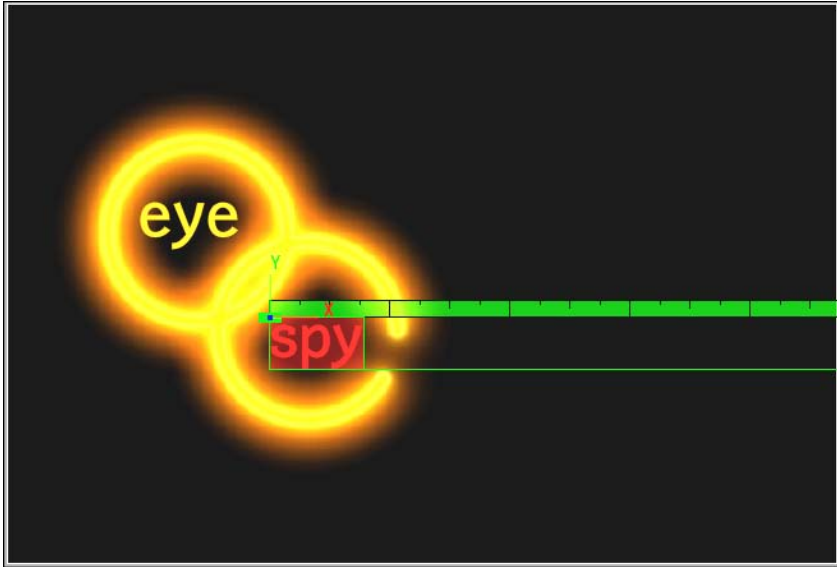
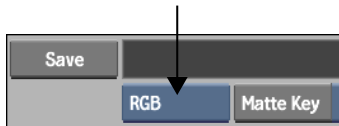

Image courtesy of Das Werk

- 4 Make a selection from the Alpha Processing Mode box to determine whether a matte is created from the text layer.



Select:	To:
RGB	Create a text layer that does not include a matte.
RGBA	Create a text layer that does include a matte.

- 5 Exit to the timeline and add an Axis key or Axis scale soft effect to the front layer.

In the following example, the text layer is created with the RGB option. The layer on which the text was created is output in the result, composited over a background layer.



Image courtesy of Casablanca, Das Werk

In the following example, the text layer is created with the RGBA option. Only the matte of the text layer itself is output in the result, composited over the background layer.



Image courtesy of Casablanca

TIP When you use the RGBA option with text to create a matte layer, select Context from the Preview Options box inside the Text editor to see the text layer with the matte.

Creating a Text Matte Key

A matte key allows you to create a text effect in which the text's fill is, in fact, a background clip. When used with an Axis effect (or a Sparks effect that takes a matte), it can be used to layer text made of one background on top of another background.

All static (non-animated) fill colours are set to a transparency of 0%.

In the following example, the front layer is used for the text's fill. The fill is then composited over the background layer with an Axis Key soft effect.

To create a text matte key:

- 1 Add two layers to the timeline.

- 2 Add a Text soft effect to the front layer and then create the text in the Soft Text editor.

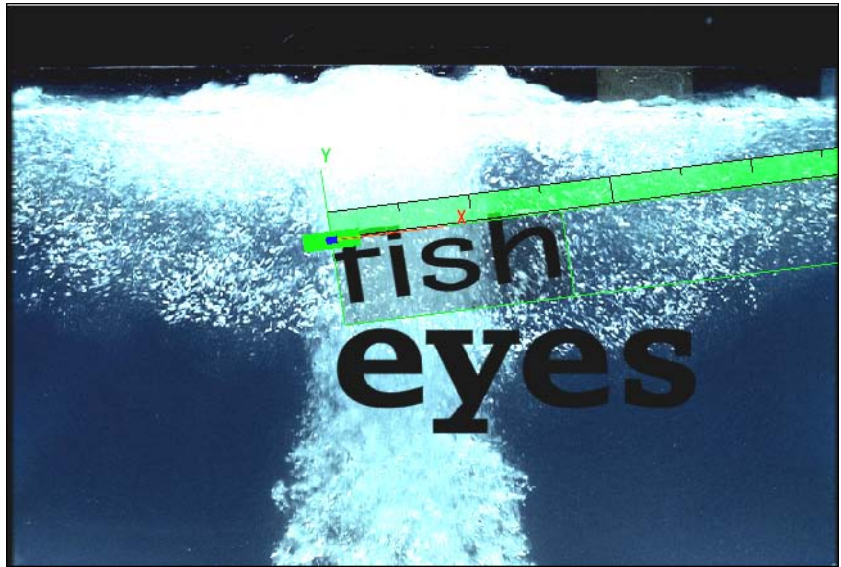

Image courtesy of Technicolor (formerly Toybox)

- 3 Enable the Matte Key button.



The Alpha Processing Mode box changes to RGBA and the Fill field resets to 0%.

- 4 Select Context from the Preview Options box to preview the effect.

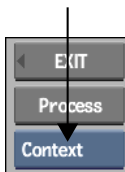

The text fill is composited over the background layer. This text layer is then applied to the timeline background layer.



Image courtesy of Quietman, Technicolor (formerly Toybox)

Trimming Animated Soft Effects

When you apply animated soft effects to timeline elements, you have three trimming options. Access these options from the soft effect's Channel box. The selected option applies to all soft effects unless they are locked.

NOTE The trimming options do not apply to Timewarp soft effects.



(a) Soft Effect Channel box

Resize Channel Locks the animation relative to the element's duration. If you change the duration of the element by trimming, the animation and all its keyframes scale to fit the duration of the element after trimming.

Link Channel Links the animation to the media. When you trim, slip, or slide the element to which the soft effect has been applied, the animation moves with the media. Keyframes move with the media as well.

Unlink Channel Unlinks the animation and the media. When you trim, slip, or slide the element to which the soft effect has been applied, the media moves relative to the animation. In this case, keyframes retain their position relative to the beginning of the element. They do not move with the media.

Creating Gap Effects

Gaps are the empty spaces between elements in an edit sequence. They can result from removing a portion of a clip with Ripple set to off, for example. To create a gap effect, apply a soft effect to a gap.

A gap effect is similar to a soft effect on an element with media. However, while a soft effect is restricted to the clip to which it is applied, gap effects are independent of all media. They affect the media under them. If you colour correct an empty layer, for example, the colour correction is seen on the layer beneath it. With gap effects, you can apply effects at a splice or transition, or add an effect to several clips at once. You can treat a gap effect like any other element, trimming and moving it, or copying it for use in another timeline.

NOTE Because a timewarp is closely tied to the media to which it is applied, you cannot apply a Timewarp soft effect to a gap.

Gaps can appear in different places in the timeline:

- The empty space between media elements on a video layer
- An empty video layer
- The space between splice points on an empty video layer. Splice points are useful for containing a gap effect applied to an empty video layer. The areas to either side of the splice points are also gaps.

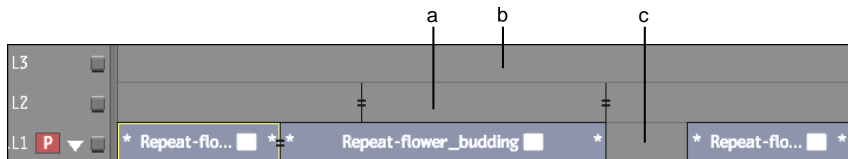

(a) Space between splice points (b) Empty layer (c) Empty space between elements

Because a gap effect is not restricted by in points, out points, splices and transitions, it is easily trimmed, moved and duplicated. You can trim a gap effect over the entire duration of the video track regardless of the underlying splice points.

You can also freely edit splices and transitions between elements on video layers under the gap effect. You can splice an element, add a transition at the splice point, and then replace the incoming element without affecting the gap effect. In addition, gap effects can be treated as clips. They can be copied and placed over different media in the timeline, or copied to the schematic for later use.

For information on creating gaps, see [Removing Elements from an Edit Sequence](#) on page 1032.

To apply a soft effect to a gap:

- 1 Determine the element to which you want to apply the soft effect. Do one of the following:
 - Move the positioner and its focus point over the gap.
 - Select the gap.
 - Select the entire video layer.
- 2 Click the appropriate soft effect button.

Creating a Soft CC over a Transition

Creating a gap effect over a transition has three advantages. First, like other gap effects, it keeps the effect separate from the underlying elements. You can modify the transition without interfering with the effect, and vice versa. Second, you only need to apply the effect once rather than to each element separately, greatly simplifying fine-tuning the effect. Finally, you can restrict the effect to just a portion of the underlying elements.

To apply a Soft CC to a gap over a transition:

- 1 Add an empty layer above a layer with a transition between two elements.
- 2 Move the focus point of the positioner to the empty layer.
- 3 Add splices before and after the start and end points of the transition.

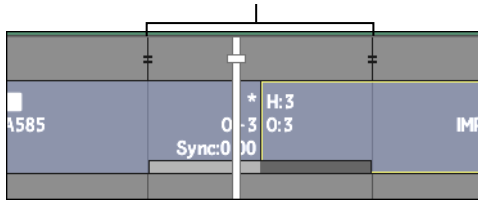

- 4 Select the gap and create a CC soft effect.

You can trim the gap effect independently of the transition, or edit the animation of the Soft CC effect without being restricted by the relative location of the cut point or the start and end frames of the transition.

Adding Soft Text to an Empty Layer

Soft Text adds text to elements in the timeline. Creating a Soft Text effect as a gap effect adds additional flexibility. Assume you want to add the same text to several clips. With a simple Soft Text effect, you would have to duplicate the effect on each clip. By creating a gap effect, you create the effect once, on an empty layer above the clips.

If you decide to put the text on a bicubic surface so that you can warp it, there is an additional consideration. To warp text, you must use the Axis soft effect, placing the text on a bicubic surface. By default, Axis soft effects use an RGB surface that contains the media of the current layer and all those beneath it. This is the case even when applying Soft Text as a gap effect. Thus, by default, warping the text will warp all the media beneath it. To restrict the warp, select the RGBA option. The RGBA option adds a matte to the gap effect, restricting the Axis effect to just the text.

To apply a Text soft effect to an empty layer:

- 1 Add an empty layer above the uppermost layer.
- 2 Select the layer and add a Text soft effect.
- 3 Enter the editor and create your text.

The text layer appears for the duration of the timeline. You can easily trim the gap effect or add fade-in and fade-out transitions. You can also edit the media elements below the gap effect without affecting the text layer.

- 4 Click outside the text layer to remove the focus.

- 5 Add an Axis soft effect so you can work with the text graphic as a 3D surface.
- 6 Enter the Axis Editor.

TIP If the Axis button is enabled, you can press ~ (**tilde**) to enter the Axis Editor.

- 7 From the Shape box, select Bicubic.



Four control points with tangent handles appear at the corners of the surface.

TIP If you do not see the control points and axis icons, select Preview FX from the Preview option box.

- 8 Use the control points to modify the shape of the surface.
By default, the Axis soft effect uses an RGB surface that contains the media of the current layer and all those beneath it. However, you only want to modify the shape of the text on top of the layers below it.
- 9 Exit the Axis Editor.
- 10 Enable Text to display the Soft Text quick menu.
- 11 From the Alpha Processing Mode box, select RGBA.

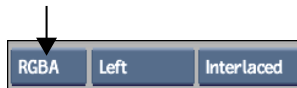

The RGBA option processes the Text soft effect using the text layers as an alpha channel. You can now modify and animate the text in 3D space independently of the video layers below it.

RGB option

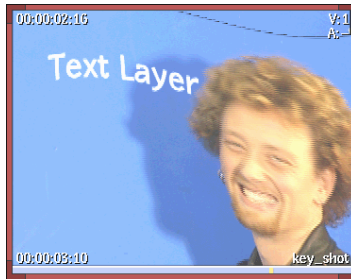

RGBA option

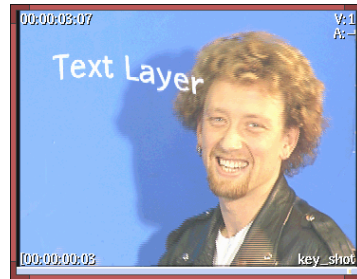

Linking Soft Effects

You can link multiple segments in order to apply or edit several segments at once. For example, if you apply the same CC soft effect to multiple segments, you can apply changes to the CC soft effect on one segment to the CC soft effect on the linked segments.

To link soft effects:

- 1 Select multiple segments on the timeline.
- 2 Add a soft effect.
- 3 Edit the settings for the entire selection using the soft effect quick menu.

Copying Soft Effects

If you want to reuse a soft effect, you can copy it from one timeline segment to another.

If you are in a BFX level, you can also copy a soft effect to a Batch setup. See [Copying Soft Effects to a Batch Setup](#) on page 1396.

To copy a soft effect:

- 1 Display the timeline of the segment with the soft effect that you want to copy.
- 2 Do one of the following:
 - Press **Ctrl** and drag the soft effect indicator to another segment.

- With the positioner over the segment with the soft effect that you want to copy, press **Ctrl** plus the number on the soft effect button, for example, press **Ctrl+5** to select the timewarp soft effect indicator. Then drag the indicator to the appropriate segment.

NOTE Soft effect indicators turn yellow when selected.

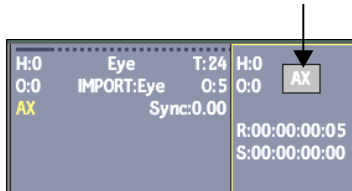

The soft effect is applied to the segment.

Muting Soft Effects

To temporarily remove a soft effect from the vertical edit, mute it. To put the soft effect back into the vertical edit, simply un-mute it. Muted soft effects are indicated by yellow LEDs on the soft effect button.

NOTE You cannot mute Timewarp soft effects regardless of where they were created.

To mute a soft effect:

- 1 Select the element that has the soft effect you want to mute.
- 2 Click the blue LED.

The LED turns yellow, and the soft effect is temporarily removed from the vertical edit.

To enable a muted soft effect:

- 1 Select the element that has the muted soft effect.
- 2 Click the yellow LED (or press the corresponding hot key number).

The LED turns blue, and the soft effect is reapplied to the vertical edit.

Deleting Soft Effects

You can delete any soft effect from the timeline.

To delete a soft effect:

- 1 Do one of the following:
 - **Alt**-click the blue LED on the left side of the soft effect button.
 - Resize the video track and **Ctrl**-drag the soft effect indicator to the bottom of the screen.
The soft effect is removed from the clip and the indicator from the segment.

Topics in this chapter:

- [About Timewarps](#) on page 1153
- [Creating Timewarps on the Desktop](#) on page 1154
- [Creating and Modifying Timewarps in the Timelines](#) on page 1160
- [Motion Estimation Using Batch Nodes](#) on page 1174

About Timewarps

A timewarp is an effect added to a clip to make the speed of the action taking place appear to go faster or slower than when it was originally recorded. This effect is created by increasing or decreasing the number of frames in the clip. Frames are duplicated or removed as needed and the action is interpolated over the new number of frames.

Create timewarps on the desktop, in the Batch or Player timeline, or using the Motion Blur node in Batch.

NOTE For recommendations on which editing tool to use for different purposes, see [Editing Essentials](#) on page 927.

You can timewarp audio using the Audio Timewarp feature. You can also apply a timewarp to audio segments on the Batch timeline. See [Applying an Audio Timewarp](#) on page 1251.

Creating Timewarps on the Desktop

Use the Timewarp command on the desktop to speed up or slow down the action in a clip by decreasing or increasing the number of frames. You can also use the timing curve in the Timewarp Editor to produce more complex timing effects. For example, reverse the action in a clip or vary the rate at which the action occurs.

From the desktop, you can create a timewarp by mixing frames together or by blending frames using an motion estimation option. For information on using motion estimation, see [Creating Motion Estimation Timewarps](#) on page 1172.

To create a timewarp by mixing frames:

- 1 In the Main menu, click Editing.
- 2 In the Editing menu, click Timewarp.
- 3 Select the source clip.

The Timewarp menu appears to the right of the Main menu.

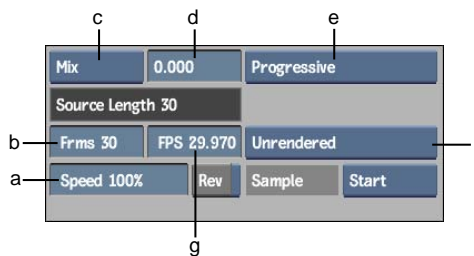

(a) Speed field (b) Frames field (c) Timewarp Processing option box (d) Mix Range field (e) Progressive/Interlaced option box (f) Render Mode box (g) FPS field

- 4 Select Mix from the Timewarp Processing option box.
- 5 Set the range for the mix in the Mix Range field.

In the timewarped clip, each frame is mixed with its preceding and succeeding frames and produces a trail effect. The Mix Range field specifies the range of frames to be used in the mix. Use a higher value to produce more of a trail effect.

The following examples illustrate the difference between mix values of 5 and 25.

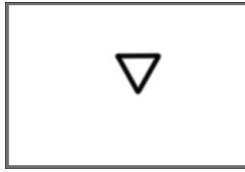

Triangle moves across the screen from left to right.



Same frame of animation with a mix value of 5.



Same frame of animation with a mix value of 25.

- 6 Set the length, frame rate, and speed of the timewarped clip by changing the values in one or more of the following fields. Changing a value in one field causes the other fields to update automatically.

To:	Enter:
Adjust the source clip to the specified number of frames	A number of frames in the Frames field.
Play the source clip at the specified frame rate	A frame rate in the FPS field.
Measure the timewarp as a percentage of the source clip	A percentage in the Speed field. A speed of 100% has no effect on the source, while a speed of 50% results in a timewarped clip that is twice as long as the source (and plays back half as fast).

- 7 To play the timewarp in reverse, enable Rev.
- 8 From the Progressive/Interlaced Render box, select to render in frames or fields.
- 9 If you selected Interlaced in the previous step, set an interpolation option. See [Timewarp](#) on page 843.
- 10 Use the Render Mode box to determine when timewarps are rendered.

Select:	To:
Rendered	Always render timewarps.
Unrendered	Never render timewarps. Timewarps will remain hidden until the clip is rendered using the Force Render command in the Editing menu. Select Unrendered if you want to edit the timewarp later in the Player or Batch timeline.

- 11 Select a sampling option. See [Timewarp](#) on page 843.
- 12 You can now create the timewarp according to the values you set or modify the values further in the Timewarp Editor:
 - To create the timewarp, select the destination reel.
 - To modify the timewarp values, click the Timewarp button. The “E” (Editor) button next to the Timewarp button is enabled. Select a destination reel. The Timewarp Editor appears. See [Modifying Timewarps with the Timewarp Editor](#) on page 1157.

Aborting Timewarps and Unrendered Frames

You can abort a timewarp as it is being generated by clicking anywhere on the screen. The frames that were not generated are replaced by frames with the message “Unrendered Frame”.

For example, if you abort a 10-frame timewarp after the first 5 frames, the first 5 frames of the timewarp are followed by 5 black frames with the message “Unrendered Frame.”

Frames with the “Unrendered Frame” message also occur when you lack framestore space. For example, when reprocessing a soft edit containing a timewarp, rather than changing the timing of the entire soft edit, “Unrendered” frames are substituted for the timewarped frames.

Modifying Timewarps with the Timewarp Editor

Use the Timewarp Editor to add complex timing effects to a clip. For example, make the action in a clip accelerate, decelerate, or move in reverse by modifying the timing curve.

To access the Timewarp Editor:

- 1 Click Timewarp.
- 2 Select the source clip.
An “E” (for Editor) appears on the Timewarp button.
- 3 Click Timewarp a second time.
- 4 Select the destination.
The Timewarp Editor appears.

Constant and Variable Timewarps

Constant timewarps have a continuous speed. In the Timewarp Editor, the timing curve for a constant timewarp is a straight line, containing one keyframe. When you modify the curve, the timewarp converts to a variable timewarp.

Constant timewarps can be edited by using the Speed field in the Timewarp menu.

Variable timewarps contain any number of keyframes. To edit the speed and curve of a variable timewarp, manipulate the speed channel. When you create a variable timewarp, a “*” appears in the timeline in place of the element's head and tail information.

Speed Curves and Timing Curves

Timewarps are created by modifying the timing of the source clip or by changing its playback speed. When you change a clip's timing, you are changing the time that it takes for a clip to reach a given frame. Take, for example, a 100-frame clip. You can adjust the timing so that only the 50th source frame is reached by the end of the clip's 100 frames. This effectively halves the clip's playback rate. A negative playback rate can be achieved by reversing a clip's timing curve (by changing the value at the last keyframe to the value of the first keyframe and the other way around).

In the Timing Curves window, a steeper timing curve results in a faster playback rate.

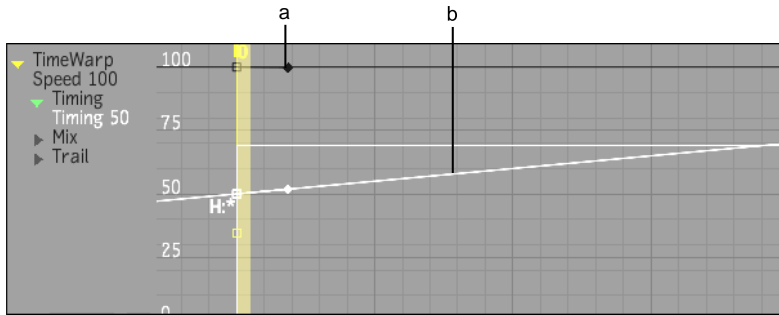

(a) Speed curve corresponding to a speed value of 100% (b) Timing curve corresponding to a speed value of 50%

Adjusting the clip's speed has different results. Setting the speed to 200% doubles the playback rate. A speed value of 50% plays the clip at half speed (or in slow motion). A negative speed value corresponds to playing the clip in reverse (where a -100% speed value creates a clip that plays back at the normal rate, but backward).

In the Timing Curves window, the speed curve and timing curve are, by definition, dependent on each other. You cannot change the speed without affecting the timing. Any action performed on one curve results in a corresponding action on the other. If you add a keyframe to the speed curve, a keyframe is automatically added to the timing curve at the same frame.

To modify a mixed frame timewarp with the Timewarp Editor:

- 1 Specify the number of frames in the new clip in the Total Frames field.
- 2 In the Progressive/Interlaced option box, select to render in frames or fields.
- 3 Set the range for the mix in the Mix Range field.
- 4 Use the Animation controls to modify the speed or timing curves by adding and moving keyframes. You can grab and drag the positioner to move to different positions in the timewarp.
- 5 Click Result to display the result clip in the image window. Click the  button to preview the result of applying the timing curve to the source clip.
- 6 When you are satisfied with the results, click Process to process the clip. The generated clip appears on the destination reel.

Adding a Trail to the Image

You can add a trail to the image that precedes and/or follows the moving object to increase the impression of speed:

- A pre trail mixes the frames that follow the current frame with the current frame.
- A post trail mixes the frames that precede the current frame with the current frame.

The number of frames used in the mix is set with the pre trail and post trail timing curves. Since you can change the shape of the timing curves, the Trail values can be varied in the clip. When you use a pre trail or a post trail, the Mix value is not used.

Setting the Fall-off for the Trail

There is one Weight field for each Pre trail and Post trail option. The Weight field specifies the fall-off for the image trail:

- When the Weight is set to 100%, there is no fall-off. The first image in the trail has the same intensity as the image in the current frame.
- When the Weight is set to 0%, the image in the current frame is at 100% intensity and the first image in the trail is at 0% intensity.

To add a pre trail or a post trail to the image:

- 1 In the Timewarp Editor, select Trail from the Timewarp Processing option box.



- 2 Adjust the Pre trail or Post trail value.
- 3 Use the Animation controls to set the timing curve for the trail by adding and moving points on the curve.

- 4 Set the fall-off value for the trail in its respective Weight field.
- 5 Click Result to display the result clip in the image window. Click the  button to preview the result of applying the timing curve to the source clip.
- 6 When you are satisfied with the results, click Process to process the clip. The generated clip appears on the destination reel.

Timewarp Editor Options

Use the desktop Timewarp Editor to set the following timewarp options.

Map Source button Determines which frame is displayed in the image window while in Source mode. The processed clip is not affected.

Do this:	To:
Enable Map Source	Interpret the current frame number as a position in the result clip. The window zoom value is scaled to display the corresponding frame in the source clip.
Do not enable Map Source	Interpret the current frame number directly as the frame number in the source clip.

Auto Key button Controls whether keyframes are set automatically by the system or explicitly by the user. To set keyframes automatically, enable Auto Key. To set keyframes manually, disable Auto Key and set the keyframes with the Set Key button in the Animation controls. This button is on the right side of the Editor. For more information, see [Accessing the Channel Editor](#) on page 1964.

Auto Scale button Automatically scales the timing curve to reflect changes to the timewarp duration.

Fit To Fill button If the source clip duration is shorter than the record clip duration, creates a fit-to-fill edit and the record clip is timewarped to fit the new duration. See [Working with Implicit Timewarps in Batch](#) on page 1162.

Creating and Modifying Timewarps in the Timelines

In the Batch and Player timelines, you can apply timewarps to video and audio segments. You can also modify the timewarp curves and create strobe effects in the Timewarp Editor.

For information on using the timeline in Batch, see [Navigating the Timeline](#) on page 969.

Constant and Variable Timewarps

Timewarp playback rates can be either constant or variable. A constant playback rate can be used, for instance, to play a clip in slow motion. A variable rate can be used to create an effect where a clip plays at its normal rate until a given action occurs, at which point the frame rate increases drastically until the action is finished, then returns to normal for the duration of the clip.

When you create a timewarp, head and tail handles are automatically created. The number of head and tail frames is determined by the speed and duration of the source. On variable speed timewarps, heads and tails are infinite (source frames are reused infinitely, as determined by the timing curve).

Because constant timewarps have a continuous speed, the curve for the timing channel in the Timewarp Editor is linear, containing one keyframe.

If you add keyframes and change the linear curve to hermite or natural, the timewarp converts to a variable timewarp. To edit the speed and curve of a variable timewarp, you can manipulate the timewarp channels and use trimming operations. A variable timewarp is identified in the timeline by a “*” in place of the element's head and tail information.

Explicit and Implicit Timewarps

Timewarps can be created in two ways in the timeline:

- Explicit timewarps are manually added to segments.
- In Batch, implicit timewarps are automatically added to the record clip when you perform an overwrite edit that would cause a difference in the record segment duration. The timewarp is added to maintain the segment duration.

NOTE You can opt to have tails added to the inserted clip rather than a timewarp. See [Timewarp](#) on page 843.

Implicit timewarps always take precedence over explicit timewarps. If you create an implicit timewarp on a source clip that has an explicit speed change specified, the explicit speed change is ignored.

Working with Implicit Timewarps in Batch

Implicit timewarps are added to the record clip when an edit causes a difference in source and record durations, and when Auto Timewarp is enabled (see [Timewarp](#) on page 843). For example, if you perform a four-point edit with ripple off and the source clip duration is shorter than the record clip duration, a fit-to-fill edit occurs and the clip is timewarped to fit the new duration.

A fit-to-fill timewarp occurs during a fit-to-fill edit (when both source in and out points, and record in and out points are specified). The speed change is automatically calculated based on source and record durations. A portion of the record clip is replaced by a portion of the source clip such that the source material is timewarped to fit the duration of the record material being replaced. The heads and tails of the source clip are retained.

NOTE A fit-to-fill edit with a negative speed change can be achieved by reversing the in and out points in the source clip, or by entering a negative value in the Speed field.

Creating Explicit Timewarps

You can create an explicit timewarp in the timeline by applying it to an existing segment.

To create an explicit timewarp:

- 1 Select the segment you want to timewarp.
- 2 Click the TW soft effect button or press **Ctrl+T**.

An unrendered timewarp for the clip is created and the Timewarp quick menu appears.



(a) Timewarp Type box (b) Speed field (c) Transition Render Mode box (d) Anchor box (e) Timewarp Processing option box

- 3 Set the Render mode to Progressive or Interlaced.
- 4 If you selected Interlaced, select an interpolation option. See [Timewarp](#) on page 843.
- 5 Select the type of timewarp—Variable Speed, Constant Speed, or Strobe. For information on creating strobe effects, see [Strobing a Clip](#) on page 1173.

- 6 Define the speed for the timewarp in the Speed field.
- 7 If you want to reverse all the frames in the segment, click Reverse.
The speed value changes to a negative number, indicating the frames are reversed.
- 8 If needed, enter a mix value in the Mix field.
You can also create a timewarp that uses a variable mix value in the Timewarp Editor. See [Creating Variable Speed Timewarps](#) on page 1167.

Editing a Constant Timewarp

When editing a constant timewarp, you can anchor a frame so that its timing is not affected. For example, to modify a timewarp without creating a bad match frame, anchor the in or out frame as you edit the timewarp.

To edit a constant timewarp:

- 1 Add a timewarp to a segment.

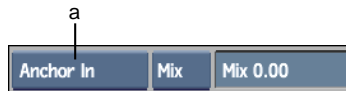

(a) Anchor box

- 2 Select an anchoring option from the Anchor option box.

Select:	To:
Anchor In	Keep the in frame from changing when modifying timewarps. The element's out frame is adjusted accordingly to conform to the playback speed specified by the timewarp.
Anchor Out	Keep the out frame from changing when modifying timewarps. The element's in frame is adjusted accordingly to conform to the playback speed specified by the timewarp.
Anchor Pos	Keep the frame at the positioner from moving when modifying timewarps. The element's in and out frames are adjusted to conform to the playback speed specified by the timewarp.

- 3 Modify the timewarp.

Converting a Clip to a Standard Frame Rate

You can add a timewarp to a clip to convert it to a different standard frame rate. For example, if you are working with PAL clips and have a few NTSC clips, you can convert them to 25 fps so that their frame rate conforms with the rest of your clips.

To convert a clip to an alternative standard frame rate:

- 1 Display the timeline for the clip.
- 2 Select the segment. If the clip has audio tracks associated with it, select all the tracks.
- 3 Press **Ctrl+T** to create a timewarp.
- 4 Change the speed percentage according to the following table.

For this frame rate conversion: Use this speed percentage:

PAL to NTSC	120%
PAL to 24p	96%
NTSC to PAL	83.33%
NTSC to 24p	80%
24p to NTSC	125%
24p to PAL	104.17%

NOTE The other timewarp parameters should use the default values, namely: Mix - 0.00, Timewarp Type - Constant Speed, Sample Options - Sample Middle, Render Type - Interlaced, No Interpolation.

- 5 Process the timewarp.

Resetting a Timewarp

Reset timewarp parameters to the default values using the Reset Timewarp box.

To reset a timewarp:

- 1 Do one of the following:
 - Select Rst Speed to reset the speed of a timewarp.
 - Select Rst All to reset all timewarp channels.

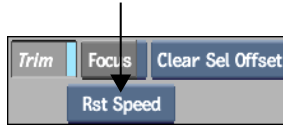

Removing a Timewarp

You can remove a timewarp from a segment in two ways:

- Select the segment with a timewarp and press **Ctrl+T**.
- Resize the segment, press **Ctrl** and drag the TW icon to the bottom of the screen.

Copying a Timewarp to Another Segment

As with any other soft effect, a timewarp effect can be lifted off the timeline and copied to the Batch schematic or to another segment on the Player or Batch timeline. See [Copying Soft Effects](#) on page 1149.

Editing Timewarps with the Channel Editor

Using the Channel Editor, you can:

- Create a variable speed timewarp by animating the speed channel.
- Change the duration by trimming the timewarp.
- Add a trail.
- Animate Mix, Trail and Timing values.
- Set the sampling option.

To access the Channel Editor:

- 1 Double-click a timewarped segment.

The speed and timing curves are shown in the Channel Editor of the Timewarp Editor.

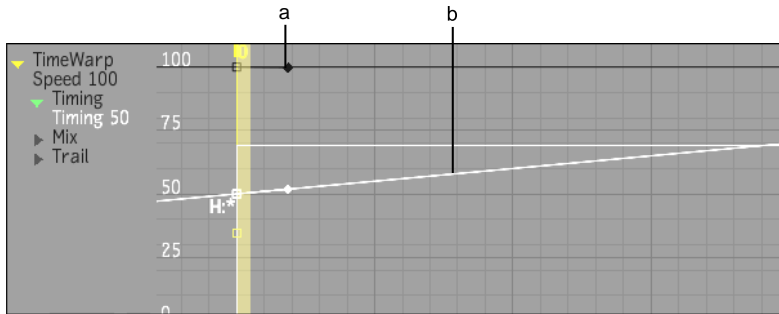

(a) Speed curve (b) Timing curve

For the timing curve, the source clip frame number is mapped along the X, or horizontal, axis. The range is from 0 at the origin to the total number of frames at the top of the graph. You cannot add frames to the source clip in the Channel Editor.

The result clip frame number is mapped along the Y, or vertical, axis. The range is from 0 at the origin to the total number of frames at the right of the graph. You can add frames to the trail of the timewarp.

Speed Curves and Timing Curves

Timewarps are created by modifying the timing of the source clip or by changing the playback speed of the source clip. When you change a clip's timing, you are essentially changing the time that it takes for a clip to reach a given frame. For example, in a 100-frame clip, you could adjust the timing so that only the 50th source frame is reached by the end of the clip's 100 frames. This effectively halves the clip's playback rate. A negative playback rate can be achieved by reversing a clip's timing curve (by changing the value at the last keyframe to the value of the first keyframe and the other way around).

A steeper timing curve results in a faster playback rate.

Adjusting the clip's speed has a different result. Setting the speed to 200% doubles the playback rate. A speed value of 50% plays the clip at half speed (or in slow motion). A negative speed value corresponds to playing the clip

in reverse (where a -100% speed value creates a clip that plays back at the normal rate, but backward).

In the Channel Editor, notice that the speed curve and timing curve are, by definition, dependent on each other. You cannot change the speed without affecting the timing. Any action performed on one curve results in a corresponding action on the other. If you add a keyframe to the speed curve, a keyframe is automatically added to the timing curve at the same frame.

Changing the Timing of a Timewarp

Edit the timing curve to adjust the timing of the timewarp. You can adjust the speed of the timewarp independently of its duration. For example, if you are satisfied with the duration of your edit and want to modify the speed of an element without changing the overall duration of your clip, adjust the timing curve without changing the position of the first and last keyframes. It is recommended to adjust either the timing curve or the speed curve for a given timewarp. It can be difficult to control the result when keyframing both curves.

The timewarp speed updates dynamically as you edit. Use the positioner to scrub the timewarp and see the results of your edits or click the  button in the playback controls.

Mix and trail values do not update dynamically.

Creating Variable Speed Timewarps

Variable speed timewarps contain animated speed and timing channels. You can create custom timewarp effects by adding and modifying keyframes for the timewarp.

To create a timewarp with a variable playback rate:

- 1 Select a segment in the timeline, then press **Ctrl+T** to create a timewarp.
- 2 Double-click the timewarped segment.
The Speed channel in the Timewarp Editor is automatically selected.
- 3 Move to the desired frame and set a keyframe.
- 4 Move the keyframe or adjust the value.

NOTE The timing curve also moves as you adjust the speed curve.

- 5 Set and adjust more speed channel keyframes as needed.

- 6 Click Return.

The timeline appears with the timewarp selected. The variable timewarp is identified in the timeline by a "*" in place of the segment's head and tail information.

- 7 Display Result view and click the  button to view the timewarp effect.

Trimming a Timewarp

Trim timewarps to change their length. This is useful if you change the speed of a timewarp and want a different length, in frame, or out frame.

You can trim timewarps in the timeline or in the Timewarp Editor. The Trim button in the Timewarp Editor is the same Trim button as in the Timeline menu. Its on or off state is carried over from one menu to the other, and it must be enabled to trim in either location.

Trimming timewarps is the same as trimming any element. If you cannot trim all the repeating frames out of a timewarp that has been reset, it is likely due to a Ripple setting constraint. Change the Ripple setting, if necessary, to trim out the unwanted frames.

NOTE Only the frames you see on a timewarp are rendered. Head and tail frames are not rendered. Use the Timeline Process option in the TL Utility box to render head and tail frames that you reveal when trimming a timewarp.

The Channel Editor also contains a Trim box for trimming timewarps.

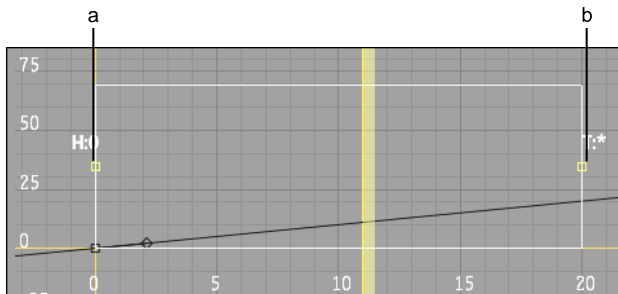

(a) Trim box in point (b) Trim box out point

The left and right borders of the Trim box represent the in point and the out point of the segment being timewarped. Head and tail frames appear outside the box.

Use the Trim box handles to trim the timewarp.

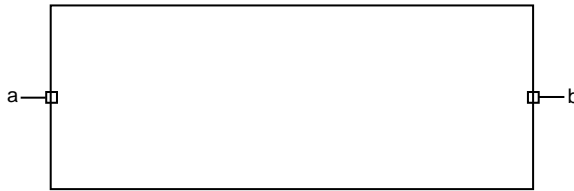

(a) Rec In handle (b) Rec Out handle

Use the Trim Lock box to determine the effect of trimming in the timeline and in the Timewarp Editor.

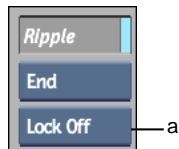

(a) Trim Lock box

Select: **To:**

Lock Off Trim the in point or out point of the timewarp without locking any frames in position.

Lock One Lock the frame on the current in point or out point when trimming a timewarp.

Lock Both Lock the frames on both transitions when trimming the in point or out point of the timewarp. This is useful for changing the speed and duration of a timewarp while respecting the in point and out point.

The following diagram shows the effect of trimming a timewarp's out point when the curve is locked and unlocked (using Lock).

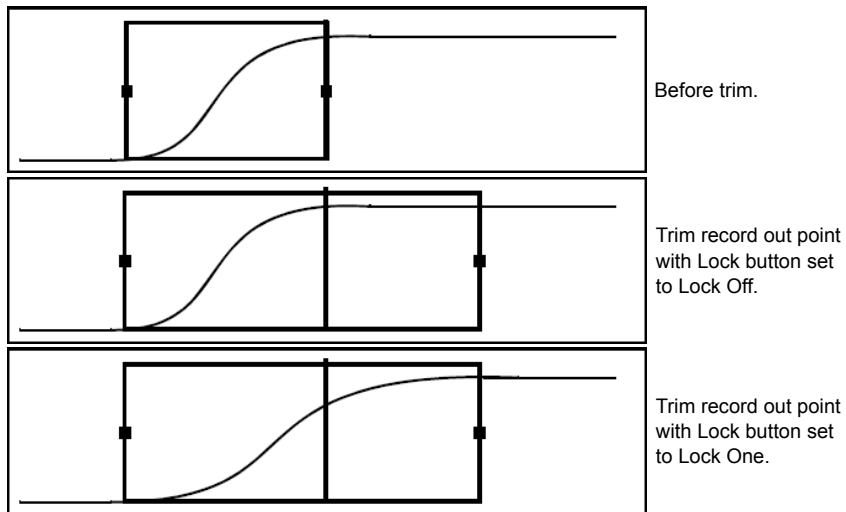

NOTE A freeze frame occurs if part of the timewarp curve is moved outside the source's in or out point while trimming or editing the timewarp curve. You can also move an entire timewarp curve outside the in and out points.

To trim a timewarp in the Timewarp Editor:

- 1 Expand the Timing channel to display the Trim box.
- 2 Enable Trim.
Trim handles appear on either side of the Trim box.
- 3 Set the Trim Lock box to Off, Lock, or Both.
- 4 Drag one of the Timewarp Trim box handles.

NOTE When timewarping a virtual source, there are no source limits.

Adding a Trail to the Image

You can add a trail to the image that precedes and/or follows the moving object:

- A pre trail mixes the frames that follow the current frame with the current frame. In the final clip, the image trail precedes the object.
- A post trail mixes the frames that precede the current frame with the current frame. In the final clip, the image trail follows the object.

The number of frames used in the mix is set with the pre trail and post trail timing curves. Since you can change the shape of the timing curves, the Trail values can be varied in the clip. When you use a pre trail or a post trail, the mix value is not used.

Setting the Fall-off for the Trail

The Weight field specifies the fall-off for the image trail. The Pre and Post field each have one Weight field.

- When the Weight is set to 100%, there is no fall-off. The first image in the trail has the same intensity as the image in the current frame.
- At 0%, the image in the current frame is at 100% intensity and the first image in the trail is at 0% intensity.

To add a constant pre trail or a post trail:

- 1 Select a segment in the timeline and then press **Ctrl+T** to create a timewarp.
- 2 Double-click the segment to access the Timewarp Editor.
- 3 If needed, adjust the speed of the timewarp using the Speed channel and the mix value in the Mix field.
- 4 Select Trail from the Timewarp Processing option box.

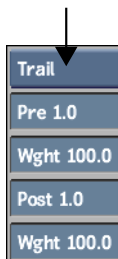

- 5 Set the pre trail value in the Pre field. Set the post trail value in the Post field.
- 6 Set the fall-off value for the trail in the respective Weight fields.

To add an animated pre trail or post trail to a segment:

- 1 Select a segment in the timeline and then press **Ctrl+T** to create a timewarp.

- 2 Double-click the segment to access the Timewarp Editor.
- 3 Enable Auto Key.
- 4 Select Trail from the Timewarp Processing option box.

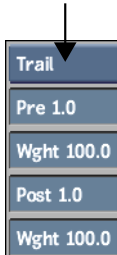

- 5 Set the pre trail value in the Pre field. Set the post trail value in the Post field.

NOTE You can also set these values in the Channel Editor.

- 6 In the Channel Editor, expand the Trail channel.
Curves for the pre trail and/or post trail appear for channels where a value was set.
- 7 Add keyframes to the curve(s) and move them to animate the effect.
- 8 Set the fall-off value for the trail in the Weight channel. Each Pre Trail and Post Trail channel has one Weight channel.
- 9 Animate the weight curves if needed.
- 10 Click the  button in the image window to preview the result of applying the trail curve to the source clip.
- 11 When you are satisfied with the results, click Return to return to the timeline.

Creating Motion Estimation Timewarps

Motion estimation analyses the pixels in each frame and interpolates the motion in the clip with sub-frame precision. Motion estimation is good for processing slow-motion constant or variable speed timewarps of interlaced and progressive material. Motion estimation is also good for material that

introduces artifacts or for which you cannot get satisfactory results using Trail or Mix values.

To process a timewarp using a motion estimation:

- 1 From the Timewarp Processing option box, select Motion.

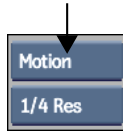

- 2 Select a Quality option.

Select:	To:
Full Res	Obtain the best results possible with pixel-accurate motion estimation.
1/2 Res to 1/16 Res	Increase processing speed by calculating motion estimation results based on progressively larger sample areas. The result is less accurate, but these options are useful for previewing purposes.

TIP In cases where your clips contain less motion, or the moving content contains little detail, the 1/2 Res or 1/4 Res Quality options may be sufficient to process the final result.

Strobing a Clip

Use the Strobe option to create a clip that repeats a specified number of frames or fields without changing the duration of the clip. The repeated frames or fields replace the original frames or fields in the clip and the timewarp curve is automatically modified with new keyframes based on the values you specify for the strobe.

The following shows a clip strobed by frames with a repeat value of 2.



Source clip (shown in frames)



Result clip (shown in frames)

The following shows a clip strobed by field 1 with a repeat value of 3.

Field 1 Field 2 Field 1 Field 2 Field 1 Field 2 Field 1 Field 2 Field 1 Field 2



Source clip (shown in fields)

Field 1 Field 2 Field 1 Field 2 Field 1 Field 2 Field 1 Field 2 Field 1 Field 2



Result clip (shown in fields)

To apply a strobe to a clip:

- 1 Select a segment in the timeline and then press **Ctrl+T** to create a timewarp.
- 2 Select an option from the Progressive/Interlaced option box.
- 3 Select Strobe from the Timewarp Type box.
- 4 Specify the number of frames or fields to repeat in the Repeat field.
- 5 To edit the Strobe curve in the Timewarp Editor, double-click the timewarped segment to access the Timewarp Editor.

Motion Estimation Using Batch Nodes

Use the Motion Analysis and Motion Blur nodes to estimate motion. The entire image is analysed and the motion between every two frames is detected. The motion can be analysed separately using a Motion Analysis node or when data is input into a Motion Blur node. You can input forward and backward

motion data into a Vector Viewer node to display the information as motion vectors. Motion vectors are displayed for each frame within an adjustable grid. They display the direction, amount, and speed of motion that occurs.

NOTE Use frame-based material when analysing motion. Because motion is estimated at every frame, you may get undesirable results if you used field-based material.

The following examples illustrate the basic principles of motion estimation. The source clip has vertical motion.



First frame



Second frame

Analysing the clip generates motion data that can be displayed as motion vectors that indicate pixel direction and speed.



First frame



Second frame

Increasing the timewarp percentage higher than 100% interpolates a frame for this sequence. This frame is interpolated by morphing the first and second original frames along the motion vectors.



First original frame



Interpolated frame



Second original frame

Motion Estimation Workflow

The following table outlines a typical workflow when using motion data in Batch.

Step:	Refer to:
1. Analyse image displacement in a clip.	Motion Analysis Node on page 1360.
2. Optionally, display external forward and backward motion data as motion vectors to verify the accuracy of motion analysis.	Applying External Motion Data to Batch Nodes on page 1176 and Vector Viewer Node on page 1373.
3. Input forward and backward motion data into the Motion Blur node.	Applying External Motion Data to Batch Nodes on page 1176.
4. Apply motion blur and timewarp settings.	Motion Blur Node on page 1362.

Applying External Motion Data to Batch Nodes

External motion data can be input into the Motion Blur and Vector Viewer nodes. For these nodes, the green tab accepts a 16-bit floating point image forward motion data and the blue tab accepts 16-bit floating point image backward motion data.

To create a motion-estimated motion blur and timewarp using external motion data:

- 1 Do one of the following:
 - Add two 16-bit OpenEXR-formatted clips with motion data to the schematic.
 - Add a Motion Analysis node to the schematic and connect a front clip to it.
- 2 Add a Motion Blur node to the schematic.
- 3 Add a front clip to the Motion Blur node.
- 4 Attach a clip containing forward motion data to the green tab.
- 5 Attach a clip containing backward motion data to the blue tab.

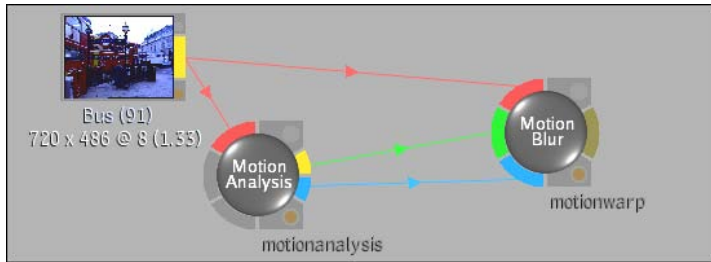

The Motion Blur nodes receives forward and backward motion input from a Motion Analysis node.

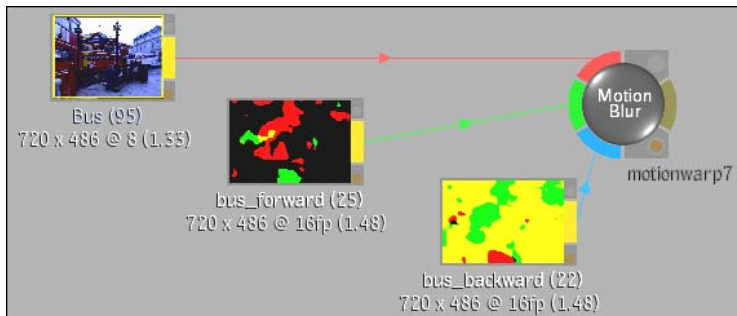

The Motion Blur node receives forward and backward motion input from 16-bit floating point clips.

- 6 Select the Motion Blur node.
The Motion Blur menu appears.



(a) The Quality option box is disabled when motion is analysed externally

- 7 Enter motion blur and timewarp settings. See [Motion Blur Node](#) on page 1362.
- 8 View the result.

To increase accuracy, increase the resolution of the backward and forward motion data. If you are using data from the Motion Analysis node, you can change the Quality setting.

To display motion analysis data as motion vectors:

- 1 Do one of the following:
 - Add two 16-bit OpenEXR-formatted clips with motion data to the schematic.
 - Add a Motion Analysis node to the schematic and connect a front clip to it.
- 2 Add a Vector Viewer node to the schematic.
- 3 Add a front clip to the Vector Viewer node.
- 4 Attach forward motion data to the green tab.
- 5 Attach backward motion data to the blue tab.

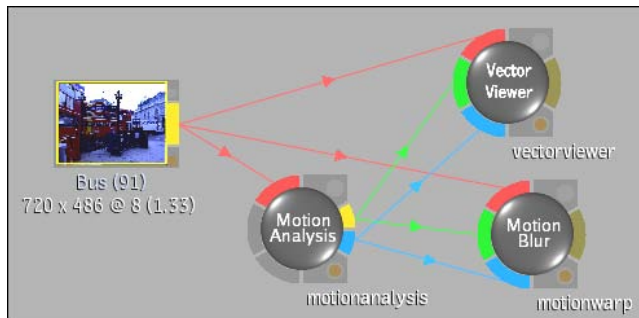

- 6 Verify the results in the Result view. You can view the vectors for forward and backward motion and modify their display for easier viewing.

To increase accuracy, increase the resolution of the backward and forward motion data. If you are using data from the Motion Analysis node, you can change the Quality setting.

Topics in this chapter:

- [About Managing Media on the Timeline](#) on page 1179
- [Identifying the Status of Timeline Elements](#) on page 1180
- [Consolidating Elements on the Timeline](#) on page 1181
- [Committing Clips on the Timeline](#) on page 1182
- [Hard Committing Specific Soft Effects](#) on page 1183
- [Merging Timeline Layers](#) on page 1183
- [Unlinking Clips on the Timeline](#) on page 1184
- [Locking Processed Timeline Elements](#) on page 1185
- [Compacting Soft Effects](#) on page 1186
- [Partial Processing of the Timeline](#) on page 1187
- [Managing Edited Clips in Batch](#) on page 1188

About Managing Media on the Timeline

During the editing process, you can manage your timeline media in various ways as you process depending on your needs. For example, to free up space on the framestore, remove unused frames by consolidating timeline elements. Or, prevent intermediate renders from occurring while you work on the timeline by compacting effects.

For information on processing from the timeline, see [Processing Soft Effects and Batch FX](#) on page 302. For information on processing Batch FX from the desktop, see [Processing Clips and Proxies](#) on page 305.

Identifying the Status of Timeline Elements

When you apply soft effects to timeline elements, colour bars appear at the top of the elements to show the process and lock status.

As you create timeline effects, you may need to process if the effect is complex or involves many layers.

NOTE Complex vertical edits that involve many layers or soft effects may require processing for real-time preview. If this occurs, black frames might be played back, or, in the viewport, frames might be dropped in order to maintain sync.

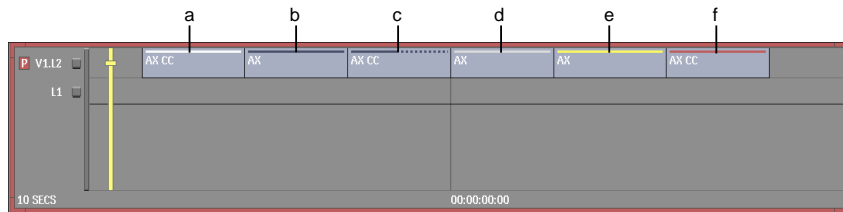

(a) Unprocessed element (b) Processed element (c) Partially processed element (d) Locked element (e) Locked element with invalidated media (f) Compacted element

Colour of Bar	Description
Black	Element is processed.
Solid and dotted black	Element is partially processed. Dotted line indicates how much of the element is unprocessed.
White	Element requires processing.
Grey	Element is processed and locked.
Dotted grey	Element is partially processed and locked.
Yellow	A locked effect with invalidated media.
Dotted yellow	Modified media under a partially processed locked element.
Red	Element contains a compact soft effect.

Colour of Bar	Description
Orange	Element is proxy processed.
Dotted orange	A partially processed proxy.
Dotted black and white	Element is sent to Burn.
Black and white checkered	Missing information; that is, processing submitted to Burn is incomplete.

Consolidating Elements on the Timeline

If you have video or audio elements on the timeline that have excessive handles, use the Consolidate option to remove head and tail frames. Consolidate your clip before archiving a project to avoid archiving a large number of unused frames. You can keep a specified number of head and tail frames when you consolidate. You can consolidate a single element or a selection of elements.

When you consolidate a container, all of its tracks are consolidated. You cannot consolidate a container composed of only one element. The length of the bottom layer of a container is used to determine the duration of the source clip. Elements on higher layers are consolidated, but not the element on the bottom layer.

To consolidate elements on the timeline:

- 1 Select the elements.
- 2 Select Consolidate from the Edit Mode box.



- 3 Enter the number of handles you want to keep in the calculator that appears.

The specified number of frames are kept; the remaining head and tail frames are removed from the selected segments.

Committing Clips on the Timeline

When you commit an edit sequence, it becomes one continuous clip. The soft properties of the sequence such as transitions, head and tail frames, and timewarp data are removed. The visual effects of the transitions and timewarps remain but you cannot edit them.

You can commit any selection of elements or tracks, or the entire timeline. It may be useful to commit a portion of an edited sequence prior to outputting your Batch setup to simplify a timeline that is too complex or to recoup disk space. Committing renders any unrendered frames on the selected elements.

You do not need to commit timeline effects to use the clip in a Batch process tree or prior to outputting the clip using the Output node. Outputting from Batch commits video effects but not audio effects.

You cannot recapture or reimport committed clips.

The result of a hard commit on adjacent elements on the timeline depends on the status of the Link Transition button. When Link Transition is enabled, adjacent elements are combined into a single element. When Link Transition is disabled, adjacent elements remain separate elements. The following rules apply to hard commits:

- Hard commits are permanent; however, they can be undone using the Undo button (as long as undos remain in the undo buffer). If you want to consolidate elements but have the ability to make changes at a later time, use containers.
- Hard commits cannot be restored—the commit is permanent.
- Hard commits force a render on the selected elements.

To commit an edit sequence:

- 1 Select the elements that you want to commit. If no elements are selected, the entire edit sequence is committed.
- 2 Select Hard Commit from the Edit Mode box.



The selected tracks or elements are committed.

Hard Committing Specific Soft Effects

You can selectively commit soft effects. Soft effects are committed in the following order:

- Axis
- Wipe
- Sparks
- CC
- TW
- Blend
- Resize
- Text

You can commit soft effects at the bottom of the list without committing soft effects above it. For example, if you have a segment with an Axis and a Colour Correction soft effect, and you commit the segment while the CC soft effect button is enabled, only the Colour Correction is committed.

You can commit the Resize soft effect without committing the Timewarp soft effect.

To selectively commit soft effects:

- 1 Select the element you want to commit.
- 2 Lock the soft effect button for the topmost effect you want to commit.
- 3 Select Commit FX from the Effect Operations box.



Merging Timeline Layers

Merging timeline layers is a quick way to generate a single layer from a multi-layer timeline.

Soft effects, including blends and wipes, are hard committed. You can then load the merged layer into Lustre, for example, and perform colour grading with the possibility of making editorial changes.

Depending on the option you select in the Preferences menu, soft transitions and clip handles may be preserved. See [Timeline Preferences](#) on page 841.

To merge layers:

- 1 Select the uppermost layer of the set of layers that you want to merge.

TIP If you make no selection, the layer set as the Primary video track is used as the uppermost layer.

- 2 From the Edit Mode box, select Merge Layers.



A new layer containing the merge layer result appears.

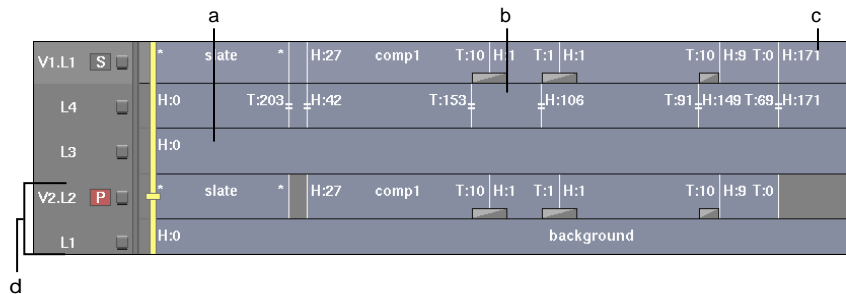

- (a) Simple Merge result (b) Complex Merge result (c) Committed Merge result
 (d) Merged layers

Unlinking Clips on the Timeline

Use the Unlink option to separate a clip's media from its metadata. This is useful when you need to free up space on the framestore. You can then delete the media if there is no other clip referencing this media. After unlinking, you can use Recapture to get back the media.



To unlink the media for a timeline element:

- 1 Select the timeline elements.
- 2 Select an Unlink option from the Edit Mode box.

Select:	To break the link:
Unlink	Between an element's metadata and media.
Unlink High Res	Between an element's metadata and the high-resolution media. You can continue to work with the proxies, but the proxies cannot be output to a VTR.

- 3 Confirm the action.
The selected clips are unlinked.

On the timeline, the element is greyed out as indicated in the following table.

Element Colour	Description
	Element with unlinked media
	Element with unlinked high-resolution media
	Element with unlinked audio

Locking Processed Timeline Elements

You can lock timeline elements so that they will not change even if you modify material on other layers. Locking elements creates a temporary soft clip that retains all material in that effect. The clip is not affected by editing operations you perform on the timeline. You can only lock processed timeline effects.

To update the timeline effect to new material or make changes in other layers, you must unlock the effect or force processing of the element.

Take care when processing and locking an effect that is part of a complex vertical. If the bottom part of the effect is moved, the effect will not be invalidated automatically. Nevertheless, the result may change once the effect is unlocked. In such cases, you can use the Timeline Force Process option.

To lock a timeline effect:

- 1 Make sure the effect you want to lock is processed.
- 2 With the positioner and focus point over the effect, or with the effect selected, select Lock FX from the Effect Operations box.



If a soft effect is locked, its corresponding quick menu is no longer displayed, even if Editing is selected from the Menu Priority box.

To unlock a timeline effect:

- 1 With the positioner and focus point over the locked effect, or with the locked effect selected, select Unlock FX from the Effect Operations box.

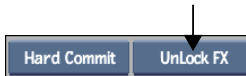

Compacting Soft Effects

Use the Compact FX option to remove intermediate renders resulting from soft effects. When you build a vertical edit and begin stacking many effects, intermediate rendered versions are created. This optimizes the workflow when entering soft effect editors and working on the timeline. You do not need to reprocess elements every time you make a change. However, intermediate renders take up additional space on the framestore and greatly increase the size of your archive. To avoid this, use the Compact FX option before archiving.

To have soft effects automatically compacted as you render, disable Fill with Intermediates in the Batch Setup menu.

To compact soft effects:

- 1 Select the timeline element.
- 2 Select Compact FX from the Edit Mode box.



Partial Processing of the Timeline

You can process selected frames of a video segment instead of the entire segment. When you later process the timeline, any frames already processed are not processed again.

If you use Preview FX mode to process soft effects of the current frame on-the-fly, any frames already processed are not processed again. The frames remain processed as long as you frame-step through the effects and do not drag the positioner. To process on the fly, make sure Cache Preview FX is enabled in the Rendering group of the Timeline Preferences menu.

To process selected frames of a timeline segment:

- 1 Place the timeline positioner at the frame where you want to start processing.
- 2 Do one of the following:
 - Select Partial from the Selection Method box, and then draw a bounding box around the frames that you want to process.

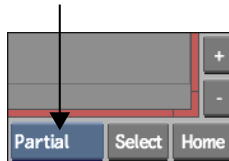

- **Shift-drag** the positioner over the frames that you want to process.

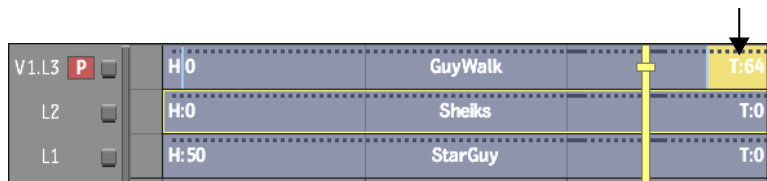

- 3 Select a Processing option.

The frames you selected are processed, indicated by a solid black line. Any previously unprocessed frames not part of your selection remain unprocessed, indicated by a dotted black line. If you processed frames that are part of a vertical edit, only the frames with soft effects that are below media with soft effects that have transparency are included in the processing. Soft effects that have transparency include Axis keying and scaling (created in Autodesk Smoke).

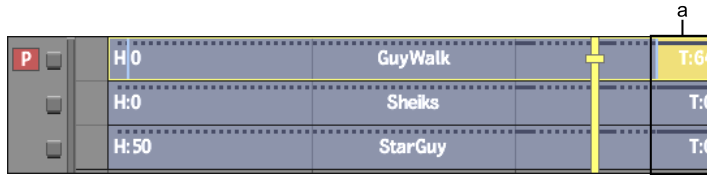

(a) Processed frames on 3 segments of a vertical edit

Managing Edited Clips in Batch

You have several options for managing edits of Batch clips. You can have edits automatically saved to a clip library or to the desktop. This option must be set before you enter Batch, and it remains in effect until the next time you start a Batch session.

If you have edited clips automatically saved to the desktop, you can either save the modified clip or a copy of the modified clip to the desktop.

If you have edited clips automatically saved to the clip library, the editing data is not saved in the setup itself, but rather as soft clips in a clip library that is created when you save the setup.

Saving to the desktop is more convenient if you plan to continue editing the clip.

Saving Edited Clips to the Desktop

When you choose to have edited clips automatically saved to the desktop, you can lock the clips to prevent the Batch setups from being accidentally deleted. All Batch clips saved to the desktop have a magenta outline. In addition, the frame number on locked clips appears in magenta.

Each time you exit a Batch session after having edited a clip, a number appears on the clip to help you keep track of versions. If the modified clip was saved to the desktop, the version number on the clip increments by one. If a copy of the modified clip was saved to the desktop, the number on each copy reflects the version.

To save an edited clip to the desktop:

- 1 In the General section of the Preferences menu, disable Use Edited Library.



NOTE You cannot change this preference when you are already in a Batch session.

- 2 If you do not want to accidentally delete edited clips that are saved to the desktop, enable Lock Edited Clips.
- 3 Select one of the following options from the Save Desktop Clips option box.

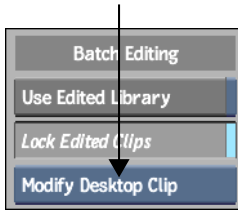

Select:	To save:
Modify Desktop Clip	The modified clip to the desktop.
Create Clip Copy for Edit	A copy of the modified clip to the desktop.

- 4 Bring a clip into Batch.
- 5 If you want to save edited clips to a specific reel other than the destination reel, in the Batch Setup menu, select Custom Reel and enter the reel number.

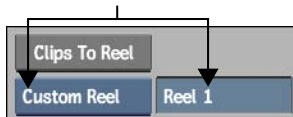

- 6 Perform editing operations on the Batch clip.
- 7 Exit back to the desktop.
The soft clip is saved to the desktop. A magenta outline indicates it is a Batch soft clip.

In the following example, the Modify Desktop Clip preference was selected. The clip was edited in five separate Batch sessions. Only the most recently modified clip appears on the desktop.

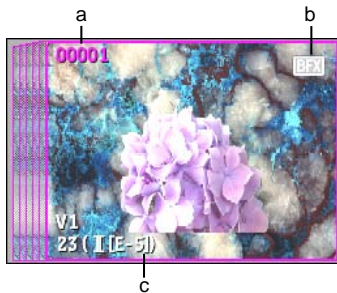

(a) Magenta frame number indicates locked clip (b) Modified soft clip with Batch FX (c) Version number of edited clip

To continue editing the Batch setup, load the soft clip back into Batch. When you exit back to the desktop, the newly modified clip will replace the one that was there previously. The version number will increment to 6.

In the following example, the clip was edited in six separate Batch sessions. The Create Clip Copy for Edit preference was selected. Each modified clip appears on the desktop with its version number.

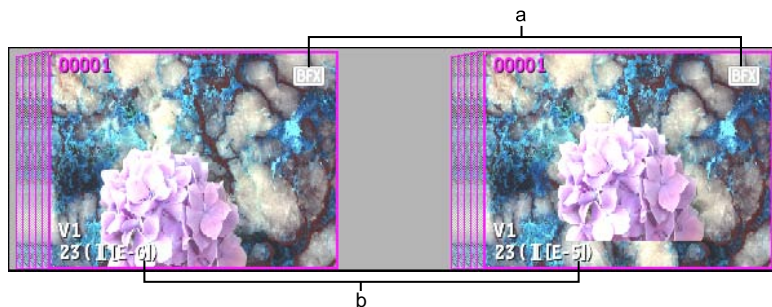

(a) Modified soft clips with Batch FX (b) Version numbers of last two edited clips

To continue editing the Batch setup, load one of the soft clips back into Batch. When you exit back to the desktop, a copy of the modified copy will appear with a magenta outline and its version number will have increased by one.

To unlock an edited clip saved to the desktop:

- 1 From the Main menu, click Lock Clip.



- 2 Select Clip from the Lock option box that appears.

NOTE If you select Reel or Desktop, all clips on the reel or all clips on the desktop will be unlocked.

- 3 Click the magenta frame number with the cursor that appears and then confirm that you want to unlock the Batch setup.

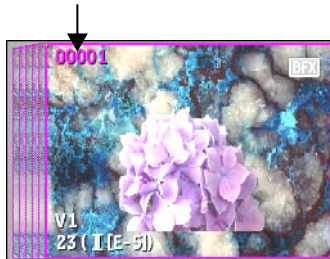

NOTE To bypass the need to confirm, **Alt**+click the magenta frame number.

The frame number turns white indicating the clip is unlocked.

Loading Batch Setups

If you saved a Batch setup with the Modify Desktop Clip preference enabled, you have two options when loading the setup. You can have Batch load any clip with the same name if it cannot find the modified clip. Or, you can have only the identical clip loaded.

The default preference is for Batch to look for any clip of the same name. To have only identical clips loaded with the setup, disable Search [E] Clips by Name in the Batch Editing section of the Preferences General menu.

With this preference disabled, the setup is loaded with a black clip icon if the clip is not found.

Saving Edited Clips to the Clip Library

When you have edited clips automatically saved to the library, they are saved to a library called *_Edited_*. The soft clips associated with the setup are saved in a reel in the *_Edited_* library. Their name is composed of the project name appended by the Batch setup name. When you load a Batch setup, the soft clips are loaded from this reel. Therefore, these soft clips comprise part of the data required to load your Batch setup.

WARNING Do not delete the *_Edited_* clip library or any of its clips unless you are sure that you no longer need your Batch setups or you have archived them.

To save an edited clip to the *_Edited_* library:

- 1 Click the General tab of the Preferences menu, and then enable Use Edited Library in the Batch Editing section.

NOTE You cannot change this preference when you are already in a Batch session.

- 2 Bring a clip into Batch and edit it.
- 3 Click Save.
- 4 Name the Batch setup and click Save again.
- 5 When you want to edit the Batch setup, go into Batch, click Load Batch, and load the setup.

NOTE You can also load the Batch setup by accessing the *_Edited_* library through the Library node.

Backups of Soft Clips

Changes you make to clips in the timeline are saved every time the Batch backup is performed. The soft clips are saved in the *_Edited_* clip library, in a reel name composed of the project name appended by *_session_*. These backed up clips remain in the reel until you start a new Batch session. When you start a session, the clips are deleted and a new *projectname_session* reel is started.

If the application crashes, when you re-start the application and enter Batch, you have the option of reloading the autosaved Batch setup. If you confirm, your edited clips are also reloaded from the *projectname_session* reel.

When a clip has been changed in the timeline, the clip proxy information in the Batch schematic changes. An [E] appears after the clip name and the clip name appears in blue rather than white. Once an edited clip has been autosaved to the _Edited_ library, it is no longer linked to the version of the clip on the desktop. Therefore, if you make changes to the desktop version, they will not be reflected in the clip in Batch.

Topics in this chapter:

- [About Working with Audio](#) on page 1195
- [About Working with Dolby E](#) on page 1198
- [Accessing the AudioDesk](#) on page 1200
- [About the AudioDesk Controls](#) on page 1201
- [Scrubbing Audio in the Player](#) on page 1203
- [Working with Audio in the Timeline](#) on page 1204
- [About Audio Soft Effects](#) on page 1214
- [Using Input Strips](#) on page 1221
- [About EQ Filter Effects](#) on page 1225
- [Adjusting EQ Settings on the EQ Desk](#) on page 1232
- [Animating AudioDesk Effects](#) on page 1239
- [About Auxiliary Effects](#) on page 1241
- [Adjusting Settings on the Auxiliary Effects Desk](#) on page 1245
- [Using Output Strips](#) on page 1246
- [Using the Audio Tools](#) on page 1248

About Working with Audio

Flame contains a number of powerful tools that allow you to edit, mix, and master your audio. You can perform many of the same editing operations that you use to edit video, such as cutting, trimming, and adding dissolves. A

comprehensive set of audio effects tools is available in the timeline, in Batch, and AudioDesk for mixing and mastering your audio.

When working with audio, you can:

- In the clip library, import and export audio files using a variety of formats. See [Supported Audio File Formats](#) on page 195 and [Supported Audio File Formats](#) on page 235.
- In the timeline, synchronize audio with video, and apply audio dissolves and fades. You can cut, trim, slip, and slide audio tracks separately from video. You can use a variety of audio soft effects such as Modulation, Delay, Reverb, Gain, EQ Filters, Compression, Noise Gate, and Audio Timewarp. You can edit these on the fly while the clip is playing. You can also assign input strips to output strips. You can also assign audio tracks to AudioDesk input strips.
- In Batch, you can import and export audio files from reels, and perform many of the audio functions available in the timeline.
- In the AudioDesk, import and export audio, adjust Gain, Pan, Mute, Phase Shift, and Solo settings for up to 32 individual input strips. You can apply these on the fly while the clip is playing. You can also assign input strips to output strips.
- In the EQ Desk, apply and adjust High Shelf, Mid Notch, Mid Presence, and Low Shelf filters to input strips.
- In the Auxiliary Effects Desk, adjust global settings for the Modulation, Delay, and Reverb Auxiliary Effects.
- In the AudioDesk, adjust the output Gain and Limiting for output strips.
- In most modules you can scrub audio and view the waveforms.

The Audio Path

In Flame, you can control the path for an audio signal and adjust audio parameters for the signal at various stages in the path. Along this path the audio signal picks up a few terms and definitions.

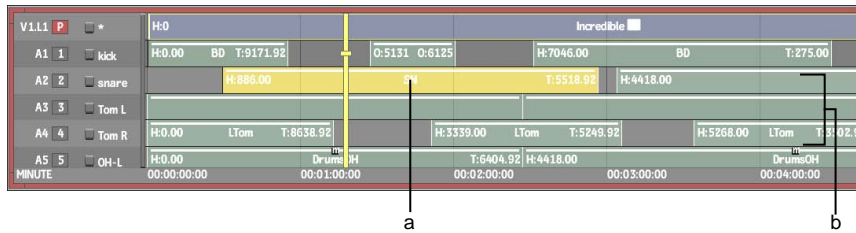

(a) Audio segment (b) Audio tracks

An *Audio Segment* refers to a discrete piece of audio. An *Audio Track* refers to a track on the timeline and may contain a number of audio segments. Audio tracks can be assigned to any of 32 *Input Strips* on the *AudioDesk*. Input strips can then be mixed down to a total of 8 *Output Strips* on the *AudioDesk*.

You can apply *Audio Soft Effects* on any audio segments in the timeline. You can also patch any number of audio segments to *Auxiliary Effects*, which are global effects modules that provide modulation, delay, and reverb audio effects for the entire sound mix. You can apply EQ effects as an audio soft effect on the audio segment or via the *EQ Desk* for an individual input strip.

The following figure illustrates a sample path for an audio signal.

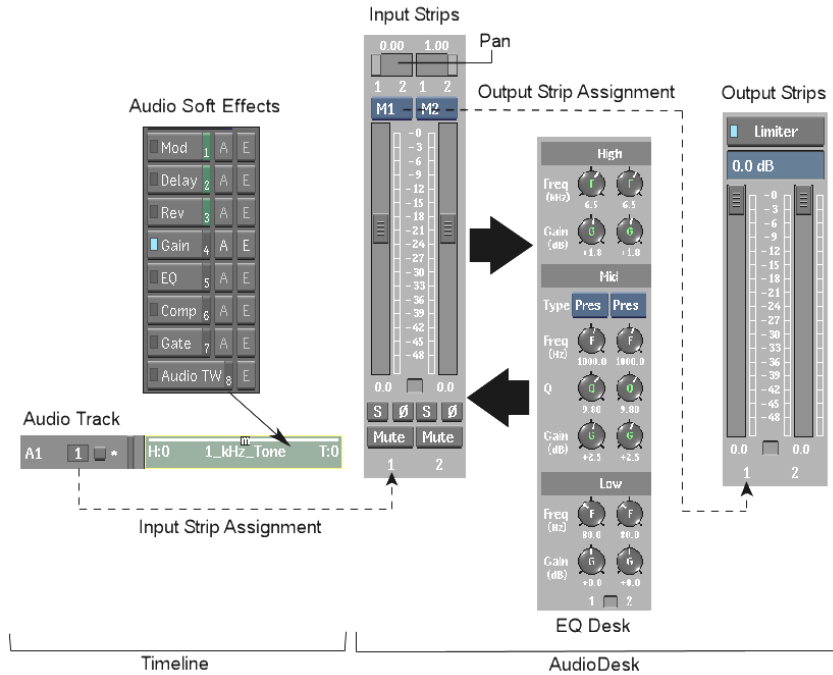

If you are using the Yamaha® O2R console, you can use it to manipulate all the audio controls on the AudioDesk, as well as assign any hot keys to the device. For complete information on obtaining and configuring the Yamaha O2R, refer to the installation guide for the respective device.

You must configure your audio system before you can use any audio features in Flame. See [Audio Preferences](#) on page 853.

About Working with Dolby E

Dolby E is a professional audio coding system, developed by Dolby Laboratories, that allows you to distribute 8 channels of high-quality digital audio (plus metadata) over existing two-channel audio infrastructures (AES-3 pairs). Post-production facilities are able to provide a variety of sound mixes, including foreign language tracks and discrete 5.1 audio over the same pair.

The frame rate of Dolby E encoded audio matches that of the accompanying video, allowing you to insert or assemble edits in Flame without audio pops or clicks and without having to use Dolby E encoders or decoders. This is very useful in cases where you need to modify a clip, for example to create a

different version or to reformat for TV broadcast, and put the clips back on tape. Dolby E works with standard PAL and NTSC video frame rates of 24 and 23.98 fps at a sample rate of 48 kHz. A DP571 Dolby E Encoder or a DP572 Dolby E Decoder is only necessary if you need to create original content with Dolby E encoded audio, or to monitor the encoded tracks.

What You Can Do with Dolby E

When working with Dolby E encoded audio tracks in Flame you can do the following:

- Play back Dolby E encoded audio from the timeline.
- Scrub Dolby E encoded audio from the timeline at standard playback speed.
- Create timelines with a mix of Dolby E encoded tracks and standard audio tracks.
- Edit Dolby E encoded audio at the frame level.
- Import Dolby E encoded audio as a file (such as AIFF 24-bits 48kHz or WAVE 24-bit 48kHz) without altering the Dolby E stream.
- Export Dolby E encoded audio as a file (such as AIFF 24-bit 48kHz or WAVE 24-bit 48kHz) without altering the Dolby E stream.
- Capture Dolby E encoded audio from a VTR while monitoring the decoded signal.
- Output Dolby E encoded audio to a VTR while monitoring the decoded signal.

Things to Consider When Working with Dolby E

When working with Dolby E encoded audio tracks in Flame you must take into account the following considerations:

- A Dolby E audio stream must not be altered in any way during capture, output, or in the timeline. For example, there can be no gain, EQ, phase, or soft-effects applied to the encoded audio tracks.
- There can be no gaps between Dolby E encoded audio segments.
- Sub-frame editing is not possible.

- Scrubbing of Dolby E-encoded audio is only possible at normal playback speed.
- When working with a mix of Dolby E tracks and standard audio tracks, you must ensure that the microfades between the audio segments in standard audio tracks are set to 10 microseconds or less. This will avoid transition pops from occurring in the standard audio tracks without breaking the Dolby E stream.
- The Dolby E DP-571 Encoder and DP-572 Decoder each have a 1-frame audio delay between input and output. Therefore, editing of the Dolby E stream must be done accordingly.

Accessing the AudioDesk

The AudioDesk includes a comprehensive set of audio tools for mixing and mastering audio. As part of the AudioDesk, the EQ Desk provides the tools for filtering audio. You can access the AudioDesk from the Player or from Batch.

To access AudioDesk from the Player:

- 1 On a desktop reel, centre a clip with audio tracks and click Play. Alternatively, place the cursor over the clip and press **Esc**.
The clip appears in the Player.
- 2 In the Player, select the Audio Desk tab.



The AudioDesk appears.

To access the AudioDesk in Batch:

- 1 Bring a clip containing audio into Batch. See [Adding Clips to the Schematic](#) on page 1285.
- 2 In the Batch schematic, select the clip.
- 3 From the Batch menu, select Audio.

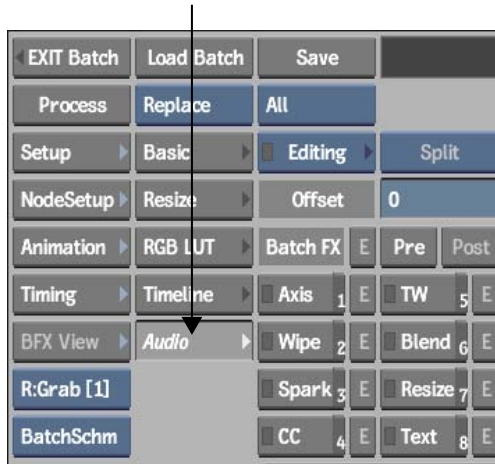

The AudioDesk appears.

About the AudioDesk Controls

The AudioDesk includes a comprehensive set of audio tools for mixing and mastering audio. The AudioDesk appears as follows.

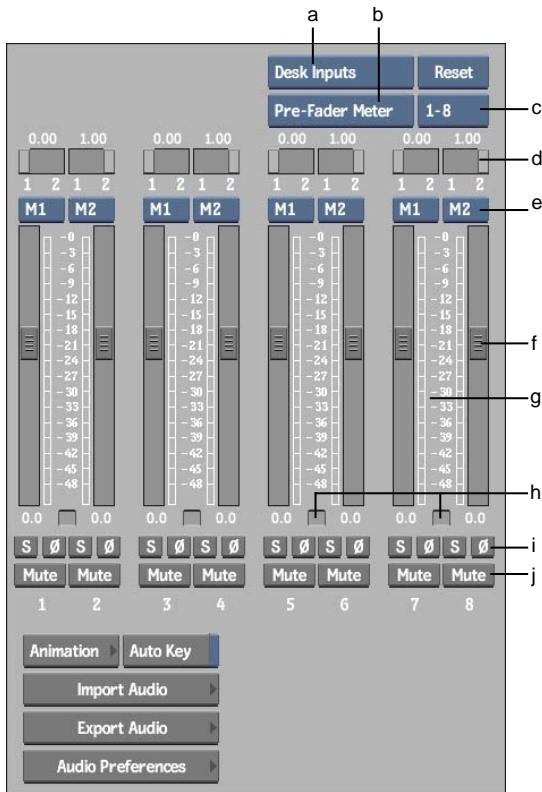

(a) Input/Output Strip option box (b) Pre-fader/Post-fader Meters option box (c) Input Strip Display selection box (d) Pan faders (e) Output Strip Assignment boxes (f) Gain Level faders (g) Input/Output Meters (h) Gain Fader Lock buttons (i) Solo and Phase buttons (j) Mute buttons

The AudioDesk controls are described as follows.

Input/Output Strip option box Toggles between Desk Inputs and Desk Outputs allowing you to see the AudioDesk input strips or the AudioDesk output strips.

Pre-fader/Post-fader Meters option box Toggles the faders to monitor audio prior to or following the application of AudioDesk and EQ Desk settings.

Input Strip Display selection box Select which set of Input Strips gets displayed.

Pan faders Pan the input strip signal between two output strips. You can adjust the pan values from 0.0 (left) to 1.0 (right).

Output Strip Assignment boxes Assign the audio signals from an input strip to an output fader. See [Using Output Strips](#) on page 1246.

Gain Level faders Control the gain for each strip.

Input/Output Meters Monitor the audio signal. For input strips, indicate the input level during recording or when in Monitor mode. When playing back a clip, the level meters indicate the playback level. For output strips, indicate playback volume. Adjust the percentage to control the volume when playing the audio track and when monitoring audio input before recording.

Gain Fader Lock buttons Move the faders individually or in pairs. See [Adjusting Gain for an Input Strip](#) on page 1221.

Solo button Temporarily mutes all input strips except the current one. See [Soloing an Input Strip](#) on page 1224.

Phase buttons Play the track with Phase inverted. For example, if phase errors are introduced, you can invert the phase for one track only. See [Phase-shifting an Input Strip](#) on page 1225.

Mute button Temporarily disables playback of the track. See [Muting an Input Strip](#) on page 1224.

Auto Key button Enables audio keyframe animation. See [Animating AudioDesk Effects](#) on page 1239.

Import Audio button Opens the Import Audio menu. See [Importing and Soft-Importing Audio Files](#) on page 229.

Export Audio button Opens the Export Audio menu. See [Exporting Audio Files](#) on page 259.

Animation button Displays the audio animation Channel Editor. See [Animating AudioDesk Effects](#) on page 1239.

Audio Preferences button Opens the Audio Preferences menu. See [Audio Preferences](#) on page 853.

Scrubbing Audio in the Player

You can scrub audio in the Player to accurately locate a precise position or a specific sound in the audio track using the positioner in the timebar. You can also scrub audio in the timeline (see [Scrubbing Audio in the Timeline](#) on page 1205).

You can perform a locked rate scrub or a free form scrub in the Player.

A Locked Rate scrub is used to scrub the audio at the normal speed of the audio or slower, depending on how quickly you drag the positioner. This is a standard audio scrub, useful for finding a precise location in the audio track.

A Free Form Scrub is used to scrub the audio according to the speed with which you drag the positioner. You will hear non-continuous synchronized audio, based on the current position. This is useful for quick interaction while dragging the positioner and to get audio feedback.

To perform a locked rate scrub in the Player:

- 1 While pressing **Ctrl+Shift**, drag the positioner in the timebar.
The audio scrubs at, or below, normal speed.

To perform a free form scrub in the Player:

- 1 While pressing **Ctrl**, drag the positioner in the timebar.
The audio scrubs with the video, and you hear the audio (synchronized with the video) intermittently.

Working with Audio in the Timeline

Once you load audio into the timeline in Flame, you can perform many of the same editing operations as you use to edit video. You can sync audio with video, cut and trim audio segments, and add fades and crossfades. You can assign audio tracks to input strips in AudioDesk. You can also apply audio soft effects and scrub, mute, and solo individual audio tracks. You can apply these on the fly while the clip is playing.

There are more ways that you can work with audio in the timeline, such as:

- You can edit your audio in the timeline. See [Editing to the Batch Timeline](#) on page 1015.
- You can create an edit sync group to keep audio and video in sync as you edit in the timeline. See [Maintaining Sync between Elements](#) on page 992.
- You can gesturally edit audio clips in the same way you gesturally edit video clips. See [Placing Shots Gesturally on the Timeline](#) on page 1021.
- You can trim audio tracks on a frame, or sub-frame basis. See [Trimming Segments Gesturally](#) on page 1054.

Assigning an Audio Track to an AudioDesk Input Strip

Assign an audio track on the timeline to an input strip on the AudioDesk to adjust audio levels and audio parameters as you edit clips on the timeline. You can assign only one track to each AudioDesk input strip.

To assign an audio track to an AudioDesk input strip:

- 1 In Timeline view, display the clip that you want to work with.

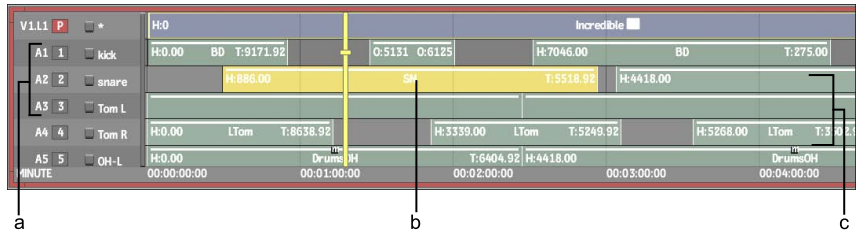

(a) AudioDesk input strip assignment (b) Audio segment (c) Audio tracks

- 2 Select the input strip in the input strip assignment beside the track identifier.

Select:	To:
Any number	Assign the audio track to an input strip.
—	Leave the audio track unassigned. (This track is not heard.)

For more information, see [Patching Video and Audio Channels](#) on page 997.

Scrubbing Audio in the Timeline

You can scrub audio at any speed between -100% and +100% of real time (locked rate scrub) or do a free form scrub. You can scrub a single audio track or all audio tracks.

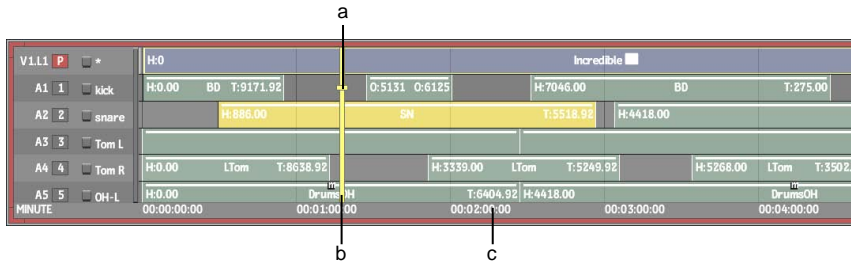

(a) Focus point (b) Positioner (c) Scrub bar

To scrub audio in the timeline:

- 1 Enable the Scrub Audio button.
- 2 Do one of the following:
 - To scrub all audio tracks, place the focus point on the video track.
 - To scrub a single track, place the focus point of the positioner on that track. See [Changing the Current Track](#) on page 979.
- 3 Click in the scrub bar at the location in the timeline where you want to scrub the audio. Continue to hold down the mouse button.
- 4 Do one of the following:
 - For a locked rate scrub, press **Ctrl+Shift** and drag the positioner left or right to scrub the audio. Dragging farther to the left or right increases the playback speed. You cannot scrub faster than real time.
 - For a free form scrub, press **Ctrl** and drag the positioner left or right to scrub the audio.

Dragging farther to the left or right increases the playback speed.

You can toggle between locked and unlocked scrub modes on the fly, by alternating between the **Ctrl** and **Ctrl+Shift** hot keys.

TIP You can quickly scrub a single track without moving the focus point by dragging the positioner with the cursor positioned over that track.

- 5 To scrub one frame at a time, press **Ctrl+Shift** and click the Back One Frame button in the player controls to go back one frame, and **Ctrl+Shift** and click the Forward One Frame button in the player controls to go forward one frame.

Viewing Audio Waveforms in the Timeline

You can view or hide audio waveforms as you work with audio in the timeline.

To view audio waveforms in the timeline:

- 1 Access the timeline for the clip you want to view.
- 2 To build waveforms for specific elements, select them. If you want to build waveforms for all audio segments, make sure that no audio elements are selected.
- 3 Click the W+ button.

The waveforms appear in the audio tracks.

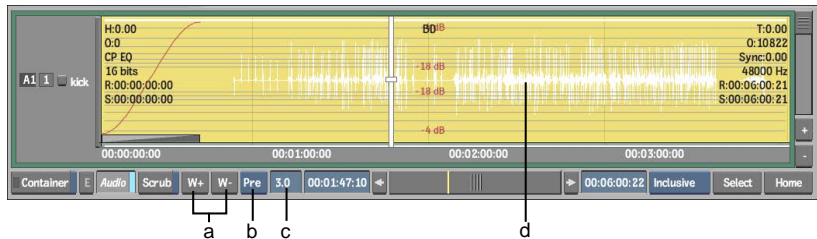

(a) W+ and W- buttons (b) Pre/Post button (c) Wave Zoom field (d) Waveform

- 4 To zoom the waveform, enter a value in the Wave Zoom field.
- 5 Toggle the Pre/Post button to see the waveform before or after applying the audio soft effects.
- 6 To turn off a waveform, select the element and click the W- button.

Applying Audio Soft Effects in the Timeline

You can apply audio soft effects to one or more audio segments in an audio track. To hear auxiliary send effects you need to mix down the audio prior to exporting the clip.

To apply an audio soft effect to an audio segment in the timeline:

- 1 Access the timeline of the clip with audio tracks. See [Accessing the Timeline](#) on page 970.
- 2 Select the audio segment to which you want to apply an effect.

- 3 Select an Audio Soft Effect that you want to apply to the audio segment.

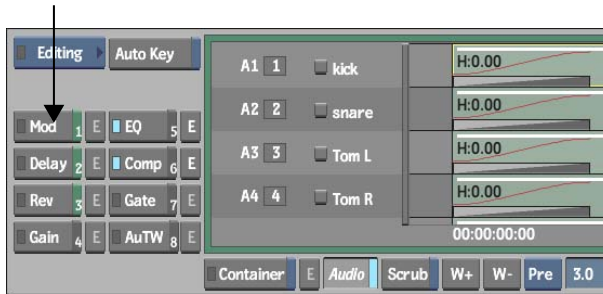

For information on how to use and adjust audio soft effects, see [About Audio Soft Effects](#) on page 1214.

Muting Audio Tracks in the Timeline

You can mute one or more audio tracks in the timeline.

To mute audio tracks in the timeline:

- 1 Hold **Ctrl** and click the track identifier for the audio track or tracks that you want to mute.

The track identifier turns yellow.

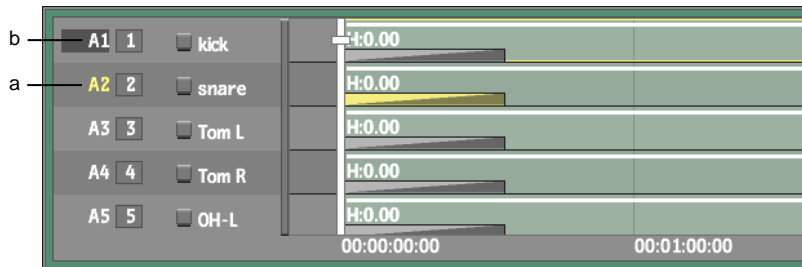

(a) This track is muted (b) Track Identifier

Soloing Audio Tracks in the Timeline

You can solo one or more audio tracks in the timeline.

To solo audio tracks in the timeline:

- 1 Hold **Ctrl+Shift** and click the track identifier for the audio track or tracks that you want to solo.

The track identifier turns red.

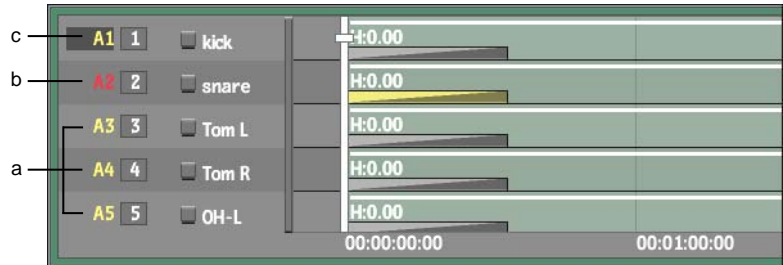

(a) These tracks are muted (b) This track is soloed (c) Track Identifier

Creating Audio Fades in the Timeline

You can create an audio fade or crossfade in the same way you add a dissolve to video elements. When creating an audio fade, you specify the duration of the fade, the interpolation for the fade-in and fade-out, and the rate of the fade.

You can also create an audio fade to or from silence.

To create an audio fade:

- 1 Select the cut where you want to add the fade.
- 2 Click Fade (or press **End**).

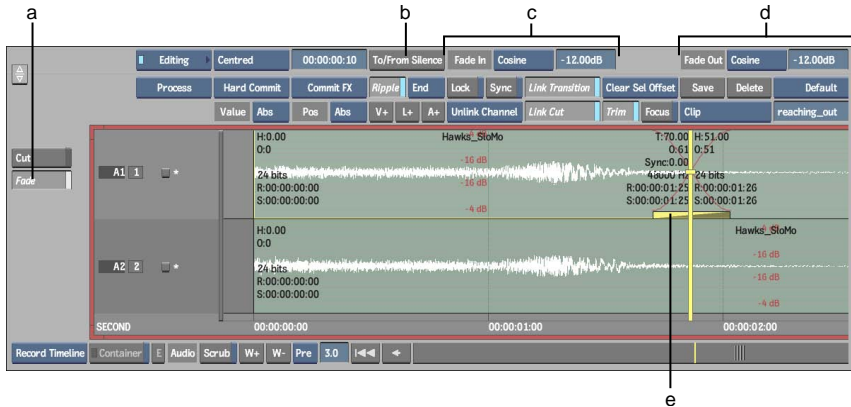

(a) Fade button (b) To/From Silence button (c) Fade In controls (d) Fade Out controls (e) Fade icon

A fade icon is added to the timeline. If you enabled waveforms, the interpolation curves appear on the audio elements.

- 3 Select and enable Editing in the Menu Priority box.
- 4 Select the alignment.
- 5 Set the transition duration.
- 6 To create a fade that dips to silence then back, click To/From Silence. The fade icon is split into two separate fades. One fade ends at the cut and the other starts at the cut. You can control these fades separately.
- 7 Use the Fade-out and Fade-in controls to select the interpolation and fade rate for the fade-out and fade-in.

Select:	To:
Linear	Create a linear fade. The slope of the fade curve is constant. See Linear Fades on page 1211.
Cosine	Create a a fade with a cosine curve. You can modify the shape of the curve by adjusting the Rate value. See Cosine Fades on page 1211.
Exponential	Create a fade with an exponential curve You can modify the shape of the curve by adjusting the Rate value. You can modify the direction of the curve by modifying the Alpha value. See Exponential Fades on page 1212.

Linear Fades

When you create a linear fade, the rate of the fade-in or fade-out is constant. This may make the fade sound abrupt because the human ear is very sensitive to changes in loudness level. If you want to make a fade sound more natural, try using a cosine curve instead.

You can view the curve by selecting the dissolve icon and clicking W+. The curve appears on the audio element.

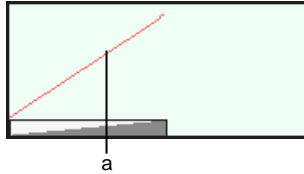

(a) Linear fade curve

Cosine Fades

When you create a cosine fade, the default rate of the fade-in or fade-out eases in and eases out. This gives a more natural sounding fade because the beginning and ending of the fade is not as noticeable to the human ear (the majority of the fade occurs at the middle of the curve.) You can view the curve by selecting the dissolve icon and clicking W+. The curve appears on the audio element.

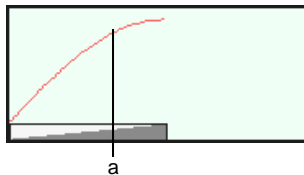

(a) Cosine fade curve

When you create a cosine fade, a Fade Curve Rate box appears in the Dissolve menu.



(a) Fade Curve Rate box

Use the Fade Curve Rate value to adjust the shape of the curve. The following illustrations show the difference between a cosine fade-in with a low curve rate, and a cosine fade-in with a high curve rate.

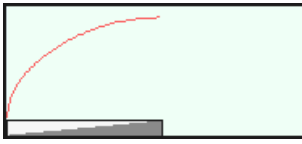

Fade Curve Rate = -0.01 dB

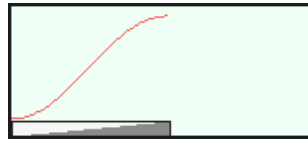

Fade Curve Rate = -12.00 dB

Exponential Fades

When you create an exponential fade, the default rate of the fade-in or fade-out is rapid at the beginning, and slows down at the end of the fade. You can view the curve by selecting the dissolve icon and clicking W+. The curve appears on the audio element.

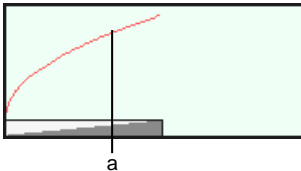

(a) Exponential fade curve

When you create an exponential fade-in, a Fade Curve Rate box and an Alpha box appear in the Dissolve menu.



(a) Alpha box

Use the Alpha value to adjust the shape of the curve. The following illustrations show the difference between an exponential fade-in with a negative alpha, and an exponential fade-in with a positive alpha.



Alpha = -1.00 dB

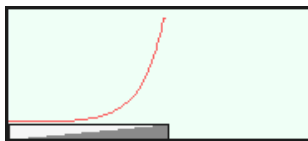

Alpha = 1.00 dB

Audio Crossfades

When you add a dissolve between two audio elements, you create a crossfade. When you add a crossfade, a Fade Curve Rate box and an Alpha box appear for both the fade-in and the fade-out. You can control the fade curve for each audio element independently.

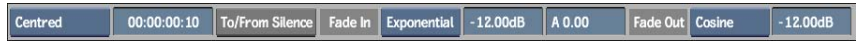

The following diagrams show a crossfade with an exponential fade-in and a cosine fade-out.

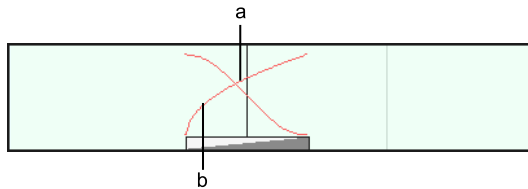

(a) Cosine fade-out (b) Exponential fade-in

Experiment with different fade-in and fade-out types to achieve the most natural sounding crossfade. For example, if the two audio elements are at noticeably different loudness levels, adjust the fade curves to get an even transition between the loudness levels.

Troubleshooting Audio Fades

Problem I can't create a multitrack audio fade-in at the start of the timeline.

Probable Cause Some of the selected tracks may not be starting at the same place at the beginning of the timeline.

Solution Because audio can be cut at the subframe level, an audio element that appears to be starting at the beginning of the timeline may actually be some fraction of a frame off (for instance, audio 2 may start a quarter of a frame after audio 1).

To fix audio fade-in problems:

- 1 Zoom in on the timeline until you can easily see each frame.
- 2 Make sure all selected tracks are lined up at the exact same place.
- 3 Trim the desired tracks until they all start at the same place, then re-apply the fade-in.

About Audio Soft Effects

Audio Soft Effects are effects that can be applied to audio segments in the timeline. All audio soft effects can be modified during playback and all audio soft effects, except Audio TimeWarp, are processed in real time. Audio soft effects can be animated. See [Animating AudioDesk Effects](#) on page 1239. Audio soft effects can also be searched for in the timeline using the Filter Select function. See [Searching for Timeline Elements](#) on page 989.

Modulation Send

Modulation Send is a soft effect that patches an audio segment to the Modulation Auxiliary Effect. All parameters for the Modulation Auxiliary Effect are set through the Auxiliary Effects panel (see [About Auxiliary Effects](#) on page 1241). You can route any number of audio segments through the Modulation Auxiliary Effect. The Modulation effect applies globally to the entire sound track and is output in stereo to a pair of output channels, combining the effect on all inputted audio segments. You can adjust the amount of modulation that can be applied to an individual segment by using the Mod Amount slider.

To apply the Modulation Send effect on a segment:

- 1 From the Record T/L, select the audio segment that you want to adjust.
- 2 From the Audio Soft-Effects menu, enable Mod.
- 3 Adjust the Mod Amount slider to any value between 0% to 100%.
This represents the percentage of the signal that will be split-off and routed to the Modulation Effect module.

Delay Send

Delay Send is a soft effect that patches an audio segment to the Delay Auxiliary Effect. All parameters for the Delay Auxiliary Effect are set through the Auxiliary Effects panel (see [About Auxiliary Effects](#) on page 1241). You can route any number of audio segments through the Delay Auxiliary Effect but the Delay effect is output in stereo to two separate output channels, combining the effect on all input segments. You can adjust the amount of delay that can be applied to an individual segment using the Delay Amount slider. You can also send the segment levels to the Left and Right Delay Channels independently using the Pan Delay slider.

To apply the Delay Send effect on a segment:

- 1 From the Record T/L, select the audio segment that you want to adjust.
- 2 From the Audio Soft-Effects menu, enable Delay.
- 3 Adjust the Delay Amount slider to any value between -96 dB and 24 dB.
This represents the amount of delay that will be applied to this segment.

Reverb Send

Reverb Send is a soft effect that patches an audio segment to the Reverb Auxiliary Effect. All parameters for the Reverb Auxiliary Effect are set through the Auxiliary Effects panel (see [About Auxiliary Effects](#) on page 1241). You can route any number of audio segments through the Reverb Auxiliary Effect but the Reverb effect is output in stereo to 2 separate output channels, combining the effect on all input segments. You can adjust the amount of reverberation that can be applied to an individual segment using the Reverb Amount slider.

To apply the Reverb Send effect on a segment:

- 1 From the Record T/L, select the audio segment that you want to adjust.
- 2 From the Audio Soft-Effects menu, enable Reverb.
- 3 Adjust the Reverb Amount slider to any value between -96 dB and 24 dB.
This represents the amount of reverb that will be applied to this segment.

Gain

Use the Gain soft effect to adjust the gain for individual segments in an audio track. Gain is the measure, in decibels, of how much a circuit amplifies a signal. You can adjust the gain for an individual segment in an audio track. You can set the segment gain to any value from -96.0 dB to +24.0 dB. The segment gain is combined with the input strip gain in the AudioDesk.

To adjust the segment gain:

- 1 From the Record T/L, select the audio segment that you want to adjust.
- 2 From the Audio Soft-Effects menu, enable Gain.

- 3 Enter the new gain level (from -96.0 dB to +24.0 dB) in the Segment Gain field that appears.

EQ

EQ is a soft effect that allows you to perform precise manipulation of the audio frequency content using the EQ Editor, which is based on a graphical display of EQ settings. For example, you can improve noisy audio tracks or enhance vocal tracks. The editor has six available filters: a High Shelf filter, a High Cut Filter, a Notch filter, a Presence filter, a Low Shelf filter, and a Low Cut filter. These filters can have a dramatic effect on the audio so they should be used sparingly.

To apply EQ effects on a segment:

- 1 From the Record T/L, select the audio segment that you want to adjust.
- 2 From the Audio Soft-Effects menu, enable EQ.
- 3 Click E.

The EQ Editor appears.

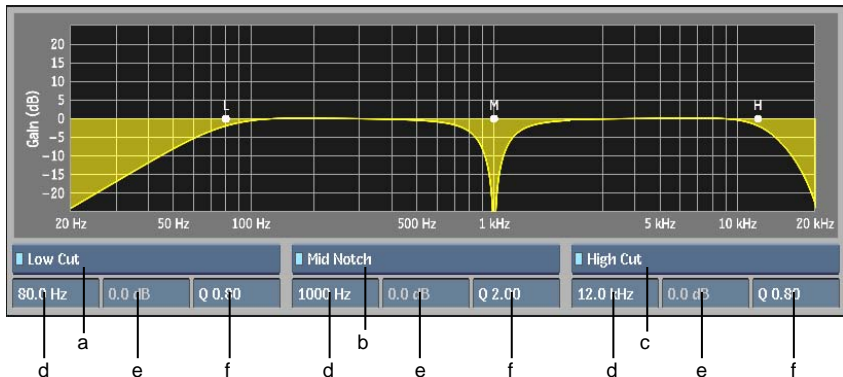

(a) Low Shelf/Cut select (b) Mid Notch/Presence select (c) High Cut/Shelf select
 (d) Frequency box (e) Gain box (f) Quality Factor box

- 4 Enable filters and make adjustments as necessary.

For information on how to set the different EQ filter effects, see [About EQ Filter Effects](#) on page 1225.

Compression

Compression is a soft effect that can be used to reduce the dynamic range of an audio signal from an audio segment. When you compress an audio signal, there is less of a difference between the lowest measured gain of the signal and the highest measured gain of the signal. Compression is useful if your audio signal has many different loudness levels that you want to play back at a similar perceived loudness level. For example, when recording voice-overs, you may want to maintain a constant perceived level of loudness in the actor's voice.

You can also compress an audio signal to attenuate portions of the signal that are too loud. For example, if your recording is at a consistent loudness level, but for some reason there is an unwanted peak in loudness level, you can compress the loud portion to give it the same perceived loudness as the rest of the recording.

Because compressing an audio signal could have a drastic effect on the overall dynamic range of the signal, it is not effective in every situation. For example, for a complex recording that has been mixed down from many other audio sources, such as a vocal track with music and sound effects, the audio signal might have complex differences in loudness levels. If you compress a master audio signal such as this, you will lose many of the original qualities of the audio signal. In such cases, it is advisable that you compress the source audio track before mixing down.

The Compression soft effect has the following controls.

Control	Values	Description
Threshold	-60 dB - 0 dB	Determines the level above which signals are affected by the compression. Signals below the Threshold are not compressed. Signals above the Threshold are compressed based on the Ratio setting.
Ratio	1:1 - 20:1	Defines the amount of gain reduction applied to the signal above the Threshold level. For example, a Ratio of 2:1 means that for every 2 dB the input signal increases, the output signal will only increase by 1 dB. Gain reduction is displayed on the compression meter.
Attack	0.1 ms - 100 ms	Defines the speed at which the compression is applied once the signal has reached the Threshold level. A fast attack rate means that most of the signal is compressed. A slow attack rate means the early part of the signal

Control	Values	Description
		will not be compressed. The result is more natural sounding than using a fast Attack.
Release	10 ms - 1000 ms or Auto	Defines the speed at which the compressed signal returns to its original value when the input signal level goes below the Threshold value. If Auto Release is enabled, the optimal value is automatically set.
Knee Width	0 dB - 40 dB	Defines the bend in the response curve. A low number gives a sharp angle and a high number gives a wider, rounded edge. A wider (or softer) knee width reduces the audible change from uncompressed to compressed. A higher knee width is most effective for higher ratios where the changeover is more noticeable.
Output Gain	-10dB - 24 dB	Defines the amount of gain to add to the output signal. For example, if you applied a lot of compression to the signal, you may want to add some output gain to set the output signal to its original overall loudness level.
Auto Release		When enabled, the optimal Release time is automatically set according to the input signal.
Peak Detection / RMS Detection		Select Peak Detection to compress the signal based on the peak levels. Select RMS Detection to compress the signal based on its average level.

Noise Gate

Noise Gate is a soft effect that can be used to lower or remove the perceptible level of noise in an audio signal from an audio segment. A noise gate does not remove noise from the audio signal.

A noise gate is commonly used when the level of the desired signal generally stays above the level of the noise. In this case, the threshold is set above the level of the noise. When the level of the signal remains above the threshold level, the gate is open and both the signal and the noise are allowed to pass through. When the level of the signal falls below the threshold level, the gate is closed and no signal is allowed to pass. In effect the perceptible noise is attenuated.

The Noise Gate soft effect has the following controls.

Control	Values	Description
Threshold	-96 dB - 0 dB	Determines the level at which the noise gate stays open. Signals exceeding the Threshold pass through unaffected. Signals not meeting the Threshold are attenuated based on the Ratio and Floor settings.
Ratio	1:1 - 20:1	Defines the amount of gain reduction applied to the signal below the Threshold level. For example, a Ratio of 2:1 means that for every 2 dB the input signal increases, the output signal will only increase by 1 dB.
Attack	0.01 ms - 10 ms	Defines the speed at which the gate will open when the audio level goes above the Threshold. A short attack rate means that the early part of the signal will not be attenuated. If the attack time is too short a click can be heard when the gate opens. A long attack rate means that most of the early part of the signal is attenuated. The result can be more natural sounding than using a short Attack.
Hold	0 ms - 1000 ms	Defines the minimum time that the gate will stay open. A longer hold time can help avoid chattering by preventing the gate from closing prematurely. For example when used with speech, the short pauses between words or sentences will not cause the gate to close.
Release	10 ms - 2000 ms or Auto	Defines how quickly the gate will close once the level has dropped below the threshold. A larger release value allows for a smooth decay rather than an abrupt cut when the gate closes.
Floor	-96 dB - 0 dB	Defines the amount of attenuation when the gate is closed.
Output Gain	-60dB - 24 dB	Defines the amount of gain to add to the output signal.

Audio Timewarp

Audio Timewarp is a soft effect used to timestretch an audio segment. With Audio Timewarp you can change the speed and duration or the pitch of the audio. Audio Timewarp uses the DIRAC Time Stretching and Pitch Shifting Technology developed by DSP Dimension (www.dspdimension.com).

Depending on the amount of timestretch applied, this soft effect may degrade the quality of the resulting audio.

To apply the Audio Timewarp effect on an audio segment:

- 1 From the Record T/L, select the audio segment that you want to adjust.
- 2 From the Audio Soft-Effects menu, enable AudioTW.
- 3 Adjust the Audio Timewarp parameters.

For information on how to set the various Audio Timewarp parameters, see [About EQ Filter Effects](#) on page 1225.

To set the Audio Timewarp parameters:

- 1 To set the speed and duration, do one of the following:
Define the timestretch parameters.

Use:	To:
Speed	Change the speed and duration of the audio clip based on a speed percentage. The values in the Time Ratio and Duration fields change automatically as you modify the speed percent.
Time Ratio	Change the speed and duration of the audio clip by setting a time ratio. This is the ratio of the number of samples in the result divided by the original number of samples. The values in the Speed and Duration fields change automatically as you modify the Time Ratio.
Duration	Change the speed and duration of the audio clip to create a destination clip with the required duration. The values in the Speed and Time Ratio fields change automatically as you modify the duration.
Pitch Shift	Change the pitch of the audio clip. Leave this option set to 1.00 X to keep the audio pitch constant when applying the timestretch. This is the ratio of the shifted frequency values divided by the original frequency values. (A Pitch shift value of 2 shifts one octave up; a Pitch shift value of 0.5 shifts one octave down.)
Quality Factor	Select the quality of the resulting audio. This can be set to Quick, Standard, or High Quality mode. Use a lower quality mode to experiment with different settings, and then use High Quality to process the final result.

Use:	To:
Time/Frequency Localization	<p>Select a time/frequency localization option that suits your audio material:</p> <p><i>Lambda1</i> - Ensures full time localization and is suitable for single-instrument tracks and voice-over.</p> <p><i>Lambda2</i> - Sets higher time localization and lower frequency localization. If applying <i>Lambda1</i> results in an echo effect, this could be a better option.</p> <p><i>Lambda3</i> - Sets the time/frequency localization in mid ranges of time and frequency domains. This is the best general-purpose setting.</p> <p><i>Lambda4</i> - Sets higher frequency localization and lower time localization.</p> <p><i>Lambda5</i> - Ensures full frequency localization and is suitable for multi-instrument tracks, such as classical music.</p>

Using Input Strips

Use the AudioDesk to adjust various audio settings of an input strip.

Adjusting Gain for an Input Strip

Use the gain faders in the AudioDesk to control the gain for an input strip. You can adjust the faders while playback is stopped, or during playback, to get a dynamic update of audio levels. Use the Gain Fader Lock buttons to specify if the faders move individually or in pairs. You can set the input strip gain to any value from $-\infty$ dB to +24.0 dB. If you define a gain level for individual segments in the audio tracks, those levels are combined with the levels defined by the input strip gain level.

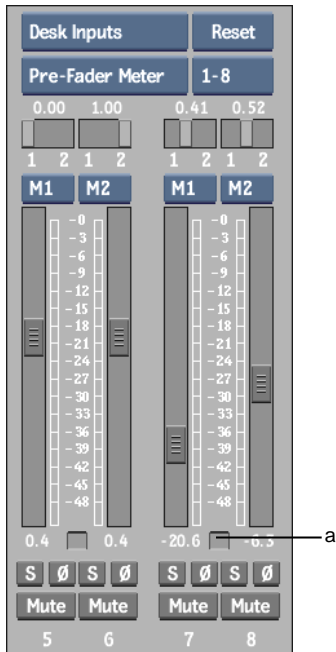

(a) Input Strip Gain display

To adjust input strip gain:

- 1 Ensure that each audio track that you want to work with is assigned to an AudioDesk input strip. See [Assigning an Audio Track to an AudioDesk Input Strip](#) on page 1205.
- 2 Play the clip. The current audio levels appear in the meters.
- 3 Do one of the following:
 - To adjust the input strip faders individually, disable the Gain Fader Lock buttons.
 - To adjust faders as a pair, enable the Gain Fader Lock button below the pair of faders.
- 4 Click the fader for the input strip you want to adjust and drag it to the new level.

The current gain level appears in the Input Strip Gain display below the selected channel. You can also adjust the levels with the playback stopped.

Assigning Audio Input Strips to Output Strips

Use the Output Strip assignment boxes to assign the audio signals from the AudioDesk input strips to different output strips. You can assign a signal from any input strip to any output strip. You can mix all signals from the track faders down to one output strip, or assign the signals to any combination of two output strips.

To assign audio to output strips:

- 1 Ensure that each audio track in the timeline that you want to work with is assigned to an AudioDesk input strip. See [Assigning an Audio Track to an AudioDesk Input Strip](#) on page 1205.
- 2 From the Output Strip assignment box for the input strip you want to assign, select the output strip you want. For example, to assign input strips 1 and 2 to output strips 2 and 5:

Set this input strip:	To this output strip:
1	M2
2	M5

You can monitor and play back audio in the Output Clip menu with any combination of audio pan and assignment settings.

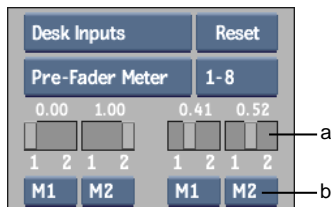

(a) Pan fader (b) Output Strip assignment box

Adjusting Pan Settings for an Input Strip

Once you assign the input strips to output strips, you can use the pan faders to pan the input strip audio signal between its own output strip and its paired output strip.

To pan the signal between left and right output strips:

- 1 Click the pan fader for the pair of output signals that you want to pan and drag left or right to slide the pan fader.

Drag:	To:
Left	Increase the amount of signal on the left output strip.
Right	Increase the amount of signal on the right output strip.
Centre	Send an equal amount of signal to the left and right output strips.

You can also specify numeric values in the pan fields to position the faders with precision.

Muting an Input Strip

You can mute an input strip. When you mute an input strip, it is not heard during playback, but its levels still appear on the pre-fader meters. You can also mute an input strip from the timeline.

To mute a strip:

- 1 Enable the Mute button for the input strip that you want to mute.

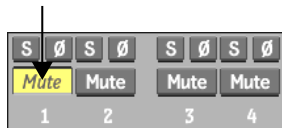

The strip is muted.

Soloing an Input Strip

You can solo an input strip. When you solo an audio track, all other tracks are muted and only the soloed tracks are played back. You can also solo an input strip from the timeline.

To solo a strip:

- 1 Enable the S button for the input strip that you want to solo.

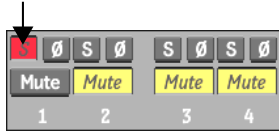

The strip is soloed.

Phase-shifting an Input Strip

You can phase-shift an input strip. Phase-shifting occurs when an audio waveform becomes displaced over time with other waveforms, causing a partial cancellation to result. If phase errors are introduced between a pair of input strips you can invert the phase for one strip to bring them back in phase.

To phase-shift a strip:

- 1 Enable the Ø button for the input strip that you want to phase shift.

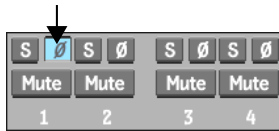

The strip is phase-shifted.

About EQ Filter Effects

EQ filter settings are used to precisely manipulate the audio frequency content. For example, use EQ filters to improve noisy audio tracks or to enhance vocal tracks. EQ Filters are accessible either from the EQ Desk to adjust input strips, or from the Audio Soft Effects menu to adjust individual audio segments. There are six available EQ filters: High Shelf, High Cut, Mid Presence, Mid Notch, Low Shelf, and Low Cut. Only the High Shelf, Mid Presence, Mid Notch, and Low Shelf filters are available on the EQ Desk.

Many filters use a quality factor, or “Q”, which affects the width of the bell curve applied on the EQ graph. A curve with a high Q covers a narrower bandwidth and means that only a few frequencies are affected. A curve with a low Q covers a wider bandwidth, affecting many frequencies.

Unless a particular effect is desired, EQ settings should be used sparingly. Almost all filters induce phase shift on the outgoing audio signal, which can

cause a problem in mixing. The higher the value of Q , the more this phase shifting occurs.

High Shelf Filter

The High Shelf filter works on the high frequencies of the audio signal (1 to 20 kHz). The High Shelf filter is useful for adding crispness to the sound. By specifying a frequency for the high EQ, you set the high shelf frequency. All frequencies above the specified frequency are boosted or attenuated, depending on the gain setting (-24 to +24 dB). The default high shelf frequency setting is 12 kHz with a gain of 0 dB.

The following diagram illustrates the result of boosting gain around the specified frequency of 10 kHz using the High Shelf filter.

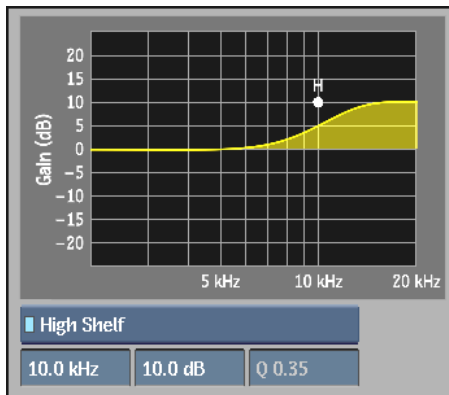

The following diagram illustrates the result of attenuating gain around the specified frequency of 10 kHz using the High Shelf filter.

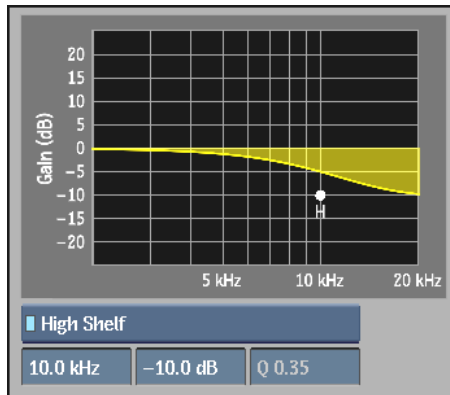

High Cut Filter

The High Cut filter (commonly known as a low-pass filter) works on the high frequencies of the audio signal (1 to 20 kHz). The High Cut filter is most commonly used to reduce noise and hiss, and to eliminate pops. By specifying a frequency for the high EQ, you set the cutoff frequency. Frequencies below the cutoff frequency pass through unaffected. Frequencies above the cutoff frequency are attenuated at a constant rate, depending on the Ratio setting. Adjust the Q curve to determine the range of frequencies affected. The default cutoff frequency setting is 12 kHz with a Q value of 0.71.

The following diagram illustrates the result of attenuating gain around the frequency of 10 kHz using a High Cut filter with a lower Q setting of 0.35.

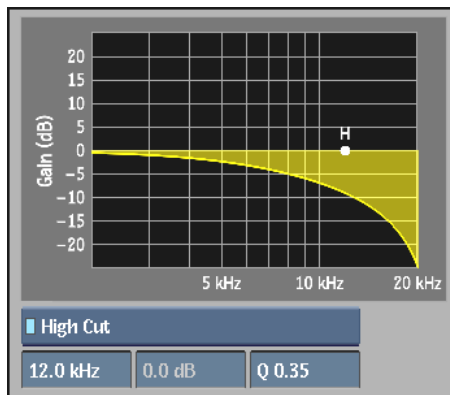

The following diagram illustrates the result of attenuating gain around the frequency of 10 kHz using a High Cut filter with a higher Q setting of 0.80.

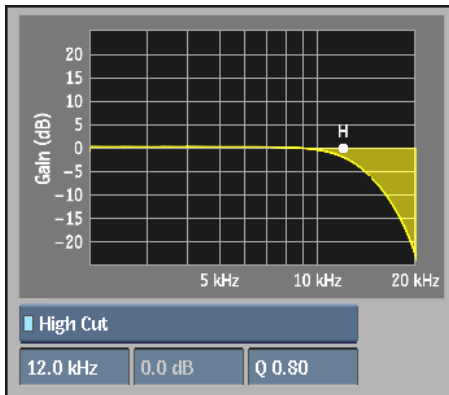

Mid Presence Filter

The Mid Presence filter is a parametric mid filter that can work on any frequency of the audio signal (20 Hz to 20 kHz). A presence filter is typically used for isolating and boosting or limiting a specific portion of the audio signal, such as a voice or an instrument. It is useful for removing background hiss or to dampen sibilance from poorly recorded vocals. By specifying a frequency for the mid EQ you can set the target frequency. Adjust the Q curve to determine the range of frequencies affected by the gain setting (-24 to +24 dB). For example, by isolating a specific frequency of a voice, you can boost or limit its gain while adjusting the Q value to prevent other portions of the audio signal from being affected. The default Mid Presence filter setting is 1000 Hz with a gain of 0 dB and a Q setting of 2.0.

The following diagram illustrates the result of boosting gain around the frequency of 10 kHz using a Presence filter with a lower Q setting of 2.00.

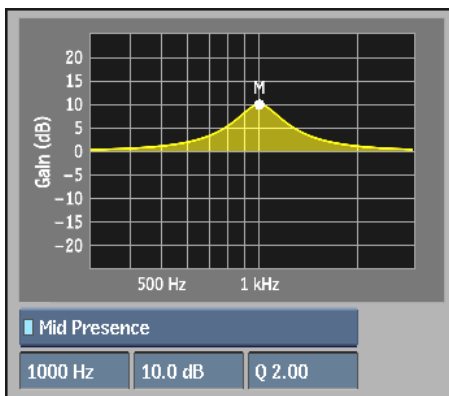

The following diagram illustrates the result of boosting gain around the specified frequency of 10 kHz using a Presence filter with a higher Q setting of 6.50.

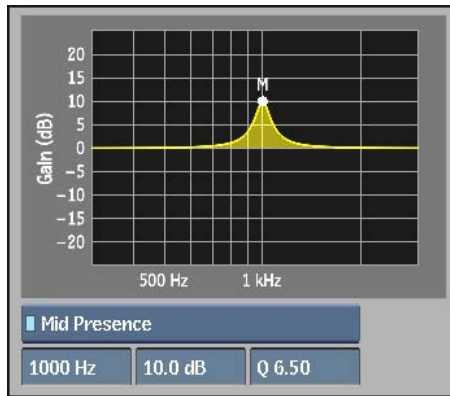

Mid Notch Filter

A Mid Notch filter is a parametric mid filter that can work on any frequency of the audio signal (20 Hz to 20 kHz). A notch filter fully limits the specified frequency range regardless of the gain setting. It is often used to reduce the 50 Hz or 60 Hz hum originating from the power source, while having little noticeable effect on the rest of the frequency spectrum. By specifying a frequency for the mid EQ, you can set the target frequency. Use the Q curve to determine the range of frequencies affected. The default Mid Notch filter setting is 1000 Hz with a Q value of 2.0.

The following diagram illustrates the result of using a Notch filter at the specified frequency of 1000 Hz with higher Q setting of 4.00.

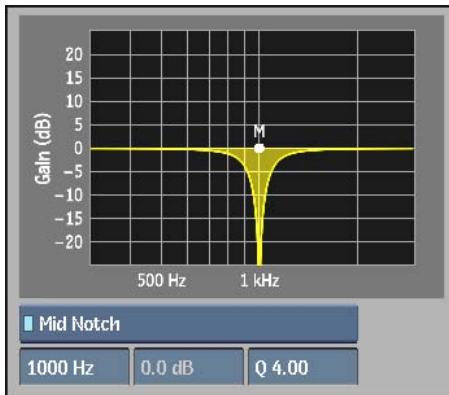

The following diagram illustrates the result of using a Notch filter at the specified frequency of 1000 Hz with lower Q setting of 0.50.

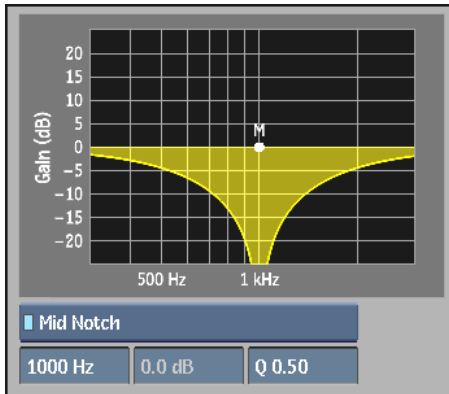

Low Shelf Filter

The Low Shelf filter works on the low frequencies of the audio signal (20 Hz to 1 kHz). By specifying a frequency for the low EQ, you set the low-shelf frequency. All frequencies below the low-shelf frequency are boosted or attenuated, depending on the gain setting (-24 to +24 dB). The default low-shelf frequency setting is 80 Hz with a gain of 0 dB.

The following diagram illustrates the result of boosting gain around the specified frequency of 500 Hz using a Low Shelf filter.

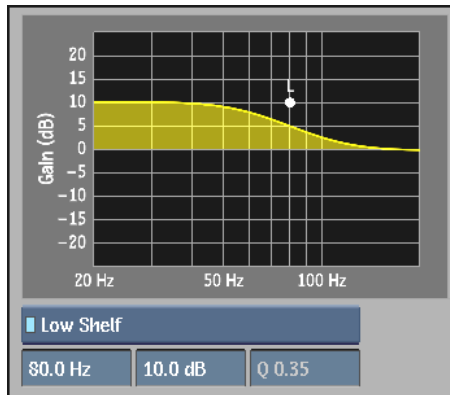

The following diagram illustrates the result of limiting gain around the specified frequency of 500 Hz using a Low Shelf filter.

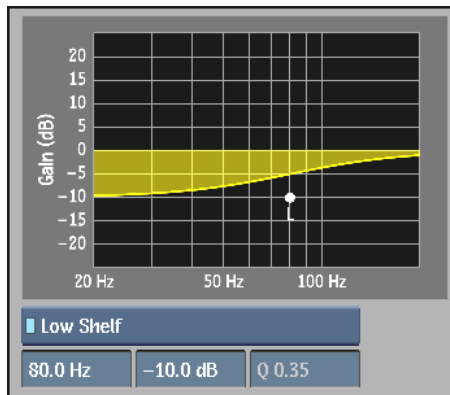

Low Cut Filter

The Low Cut filter (commonly known as a high-pass filter) works on the lower frequencies of the audio signal (20 Hz to 1 kHz). The Low Cut filter is often used to reduce low frequency noise such as rumble. For example, when recording vocals it is common to use a low cut filter at about 60 to 80 Hz for this purpose. By specifying a frequency for the low EQ, you set a cutoff frequency. Frequencies above the cutoff frequency pass through unaffected. Frequencies below the cutoff frequency are attenuated at a constant rate, depending on the Ratio setting. The default cutoff frequency setting is 80 Hz with a Q value of 0.71.

The following diagram illustrates the result of limiting gain around the specified frequency of 500 Hz using the Low Cut filter with a lower Q setting of 0.35.



The following diagram illustrates the result of limiting gain around the specified frequency of 500 Hz using the Low Cut filter with a higher Q setting of 0.80.

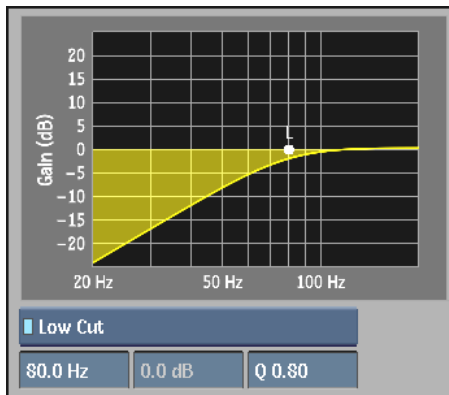

Adjusting EQ Settings on the EQ Desk

Use the EQ Desk to adjust the EQ for each audio track. The EQ Desk allows precise manipulation of the audio frequency content. For example, use it to improve noisy audio tracks or to enhance vocal tracks. Each desk strip has three available filters: a High Shelving filter, a Parametric Mid filter, and a Low Shelving filter. Each can provide as much as 24 dB of boost or attenuation.

You can animate all EQ Desk values. See [Animating AudioDesk Effects](#) on page 1239.

To adjust the EQ settings:

- 1 In Player, select the Audio Desk tab.

The EQ Desk appears.

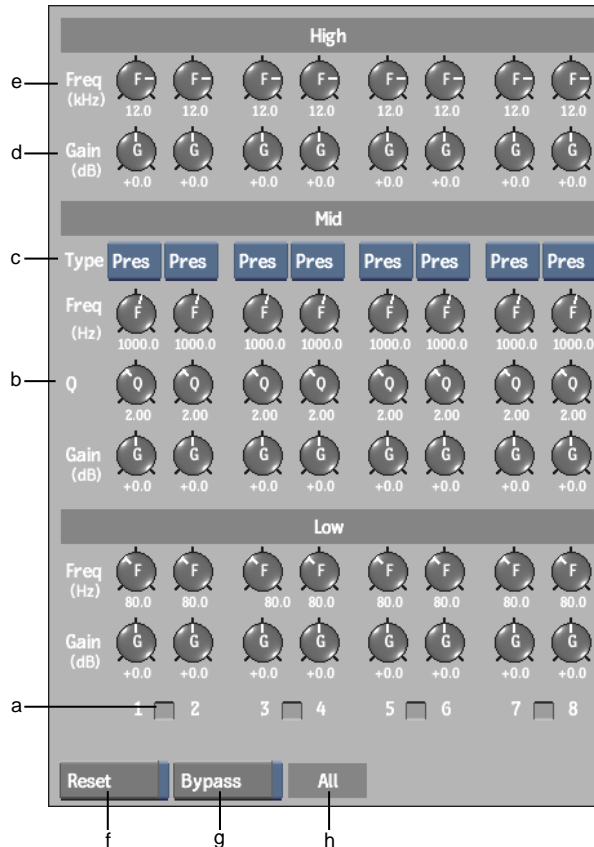

(a) EQ Lock button (b) Q knobs (c) Filter Type boxes (d) Gain knobs (e) Frequency knobs (f) Reset button (g) Bypass button (h) All label

- 2 Hold the cursor over the knob for the Frequency, Gain, or Q value that you want to adjust.

Two white arrows appear indicating the direction you can move the mouse or pen.

- 3 Drag the knob to the new value.

The knob is highlighted green when it is a value other than the default setting.

The EQ Desk controls are described as follows.

Frequency knobs Select the frequency for the EQ.

Gain knobs Boost or attenuate the selected frequency.

Filter Type boxes Display Presence or Notch filter for the EQ strip.

Q knobs Adjust the Q for the parametric EQ.

EQ Lock button Adjust the EQ individually or in pairs.

Bypass button Enable to bypass selected EQs.

Reset button Enable to reset selected parameters.

All label Reset or bypass all parameters. Active when either Bypass or Rest are enabled.

Using Parametric Mid Filters

The Notch and Presence Parametric Mid filters can be used to reduce or remove unwanted audio anywhere in the frequency spectrum.

To reduce or remove an unwanted frequency using Parametric Mid filters:

- 1 Ensure that each audio track that you want to work with is assigned to an AudioDesk input strip. See [Assigning an Audio Track to an AudioDesk Input Strip](#) on page 1205.
- 2 Play the clip and listen for the unwanted portion of the audio signal.
- 3 Boost the gain for the Parametric Mid filter of the EQ strip that you are working with.
- 4 Play your audio clip again.
- 5 While the audio is playing, click and drag the Frequency knob for the Parametric Mid filter.
The unwanted frequency will be very loud when you have selected the correct frequency.
- 6 Once you isolate the unwanted frequency, stop dragging the Frequency knob.

- 7 Do one of the following:
 - To reduce the frequency, select Presence from the Filter Type box and lower the gain knob for the Parametric Mid filter enough so that the unwanted frequency is attenuated without affecting the overall audio signal.
 - To remove the unwanted frequency completely, change the filter type to Notch.

Resetting EQ Values

You can reset the EQ values to default for a single knob, a range of knobs, or an entire input strip.

To reset EQ values:

- 1 On the EQ Desk, enable Reset.

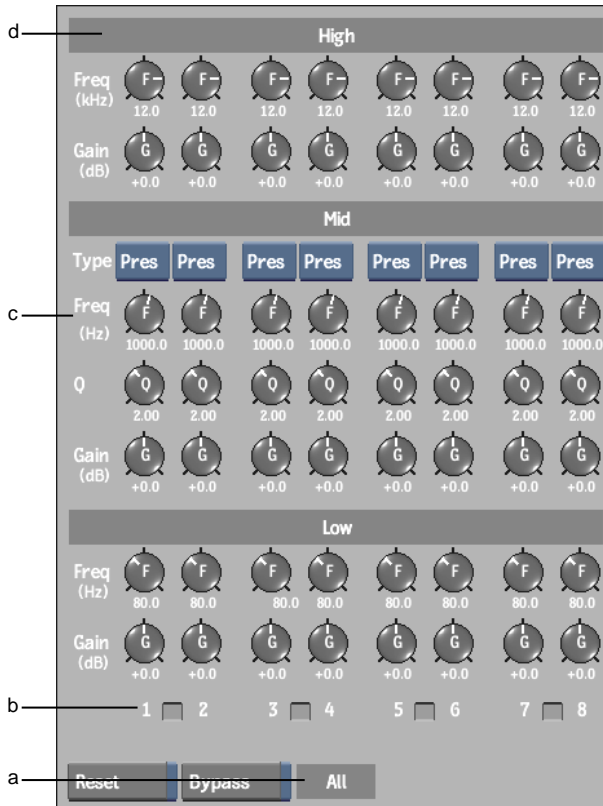

(a) All label resets everything (b) Track label resets the entire input strip
 (c) Parameter label resets the entire row (d) Group label resets all values within group

2 Reset the applicable EQ value by clicking it, as follows.

To reset:	Click:
An individual knob.	The knob.
A row of EQ values.	The Freq, Gain, Type, or Q type parameter label.
All EQ values of a group.	The High, Mid, or Low group label.
All EQ values for a single input strip.	The track label. If a channel is locked with another, both are reset.

To reset:**Click:**

All EQ values.

The All label.

TIP Instead of using the Reset button, you can also **Ctrl**-double-click knobs and labels to reset values.

Bypassing EQ Values

You can bypass filter groups or filter rows in the EQ Desk, temporarily removing the effect of the EQ changes you made to isolate a particular filter group and adjust the quality of the audio. You can use this capability to compare the original, unchanged track with the track with EQ changes applied to it. Note that bypassing EQ changes affects both playback and output. Also, if you perform a mixdown on a track with bypassed EQ values, the values are not applied to the processed clip. See [Mixing Down Audio](#) on page 1253.

To bypass an EQ setting:

- 1 On the EQDesk, enable Bypass.
The cursor changes to a stop sign.

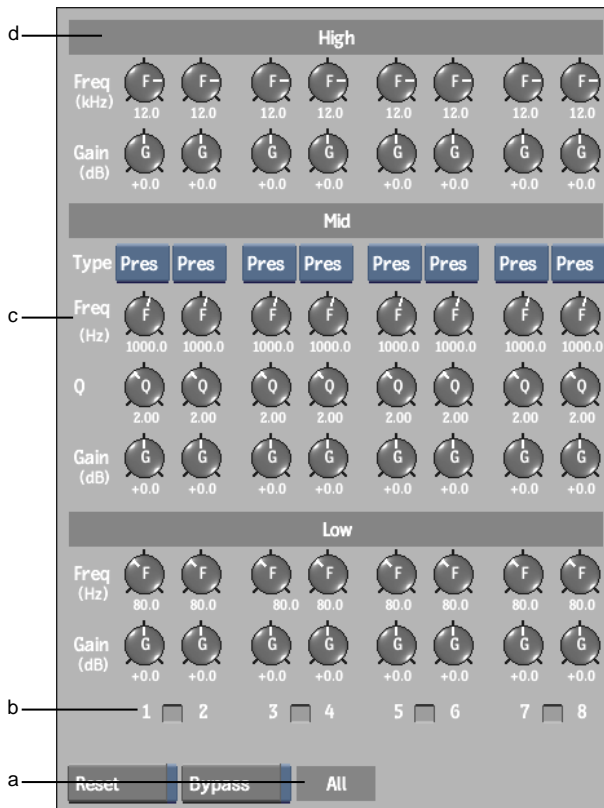

(a) All label bypasses everything (b) Track label bypasses the entire input strip (c) Parameter label bypasses the group (d) Group label bypasses the group

2 Bypass the filter or filter area that you want to bypass by clicking it, as follows.

To bypass:	Click:
A filter.	One of the knobs for that filter.
A filter group.	The High, Mid, or Low group label, or the Freq, Gain, Type, or Q type parameter label within the selected group.
All filters for a single input strip only.	The track label.
All filters.	The All label.

The values below the knobs appear grey to show that they are not being used.

Animating AudioDesk Effects

You can create audio animations with real-time playback by animating audio soft effects and input strip effects such as audio levels, pans, and EQ both on the AudioDesk and in the Channel Editor. Your animation can be as simple as gradually raising the volume and then suddenly lowering it. In contrast, you can create a complex audio animation so that specific audio waveforms coincide with video effects and various transitions on the timeline.

All audio animations are linked to the track (as opposed to the individual audio segments) and relative to the start of the track. That means when you make changes in the timeline, such as deleting or adding segments in the track, your audio animations may fall out of sync with the audio segments.

You can not animate auxiliary audio effects, but you can animate the segment send effects.

To animate audio levels:

- 1 On the AudioDesk, enable Auto Key.
- 2 Play back the audio.
- 3 On the AudioDesk, change the audio levels while the audio is playing back.

A tilde appears next to the audio tracks indicating there is animation.

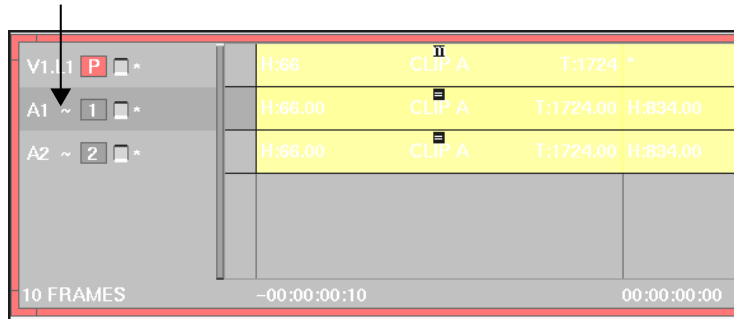

- 4 Stop the playback.

- 5 To view the animation channels, double-click the audio track on the timeline. Alternately, click the Animation button.
- 6 In the channel hierarchy of the Channel Editor, click the Strip 1 Track A1 channel.
- 7 Select the Input_Fader channel and click Frame Chn in the Animation controls.

The Input_Fader curve appears in the animation curve window.

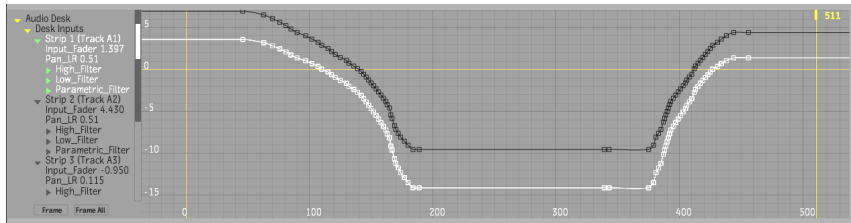

- 8 Tweak the keyframes according to the fade-in and fade-out effects you want. See [Editing Keyframes](#) on page 2001.
- 9 Click Undo to undo changes and make modifications to the audio animation.

To animate EQ Desk controls:

- 1 On the AudioDesk, enable Auto Key.
- 2 On the timeline, select one or more audio tracks.
- 3 Play back the audio.
- 4 On the EQ Desk, change the settings for any of the filters while the audio is playing back. See [Adjusting EQ Settings on the EQ Desk](#) on page 1232. A tilde appears next to the audio tracks indicating there is animation.
- 5 View the animation keyframes in the Channel Editor.

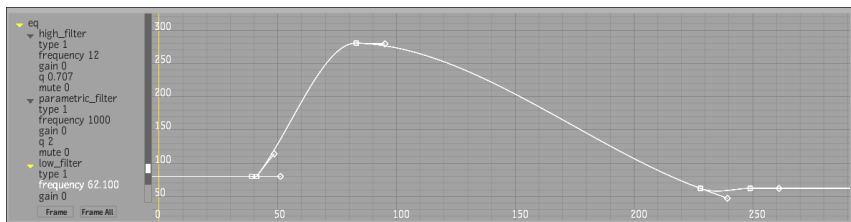

The High Shelf Filter settings are included in the High_Filter folder of the channel hierarchy, the Low Shelf Filter settings are included in the Low_Filter folder of the channel hierarchy, and the Parametric Mid Filter settings are included in the Parametric_Filter folder of the channel hierarchy.

- 6 Tweak the keyframe values for these channels as required for the audio animation effect you want to obtain. See [Editing Keyframes](#) on page 2001.

About Auxiliary Effects

Auxiliary Effects are global effects modules that provide modulation (phaser, flanger, and chorus), delay, and reverb audio effects. The outputs of Auxiliary Effects are stereo, and are patched to a single pair of output channels. You can send the audio signals of any number of audio segments to the Auxiliary Effects modules. At the segment level, you can adjust how much of the audio signal is sent to the modules using any of the Modulation Send, Reverb Send, or Delay Send audio soft effects. See [About Audio Soft Effects](#) on page 1214. All other parameters for Auxiliary Effects are adjusted using the Auxiliary Effects panel. The parameters for each Auxiliary Effect apply globally to all audio segments patched to it.

Modulation

The Modulation Auxiliary Effect consists of three audio sub-effects: Phaser, Flanger, and Chorus. You can only apply one of the three Modulation sub-effects for an entire sound mix. If you need to use more than one Modulation sub-effect in your mix, you will have to create a separate mix with that effect, or mixdown a specific segment or segments with that effect and insert it into another sound mix.

Phaser

The phaser produces the classic “swooshing” sound that characterizes phasing. The phaser effect is based on a two-voice stereo algorithm and works by shifting the phase of the signal (Delay) and adding it back to the original signal (Feedback), causing partial cancellation of the frequency spectrum. In effect, this creates notches in the frequency domain that eliminate sounds at the

notch frequencies. The position (Depth) of these notches varies over time, and the phaser includes a low frequency oscillator (Speed) for this purpose.

Control	Values	Description
Delay	1.0 - 30.0 ms	Defines the average phase Delay between the input signal and the filtered output. Default is 1.2 ms.
Depth	0 - 100%	Defines the depth of the phase modulation, or the amount that the Delay time is varied. Default is 100%.
Speed	0.1 - 2 Hz	Defines the phase modulation rate. Default is 0.9 Hz.
Feedback	0 - 100%	Defines the amount of output signal fed-back to the input. This produces a resonance effect that intensifies the peaks and lows. Default is 0%.
Output Gain	-96 - 0 dB	Default is 0 dB.

Flanger

The Flanger effect applies a modulation sweep effect to the audio signal. Flanging has a very characteristic sound that many people refer to as a "whooshing" sound, or a sound similar to that of a jet plane flying overhead. It is generally used as special effect on electric guitars. The flanger effect is based on a two-voice stereo algorithm and works by introducing a 90° phase offset between each voice (Delay). This produces peaks and notches in the resulting frequency spectrum. Varying the delay between the two voices (Depth) causes these to sweep up and down the frequency spectrum. The signal can be inverted and fed back (Feedback) to the original voice, producing a resonance effect which gives a more characteristic flanging sound.

Control	Values	Description
Delay	1.0 - 30.0 ms	Defines the average phase Delay between the input signal and the filtered output. Default is 0.7 ms.
Depth	0 - 100%	Defines the depth of the modulation sweep, or the amount that the Delay time is varied. Default is 64%.
Speed	0.1 - 2 Hz	Defines the modulation sweep rate. Default is 0.9 Hz.
Feedback	0 - 100%	Defines the amount of output signal fed-back to the input. This produces a resonance effect that intensifies the peaks and lows. Default is 0%.

Control	Values	Description
Output Gain	-96 - 0 dB	Default is 0 dB.

Chorus

The Chorus effect makes a sound appear as many similar sounds coming from multiple sources, such as a chorus from a group of singers. It adds thickness to the sound, and is often described as “lush” or “rich”. The chorus effect is based on a 4-voices stereo algorithm. The chorus effect can make a single instrument sound like there are actually several instruments being played. There is a 90° phase offset between each voice. The effect applies a delay to the audio signal (Delay) and pitch modulates it (Depth).

Control	Values	Description
Delay	1.0 - 30.0 ms	Default is 5.0 ms.
Depth	0 - 100%	Defines the depth of the chorus effect. Default is 80%.
Speed	0.1 - 2 Hz	Defines the pitch modulation rate. Default is 0.2 Hz.
Feedback	0 - 100%	Default is 0%.
Output Gain	-96 - 0 dB	Default is 0 dB.

Delay

The Delay effect temporarily stores an audio signal then plays it back after a period of time (Delay). The delayed signal may fed back into the recording again (Feedback), to create the sound of a repeating, decaying echo. It is different from reverb, which creates a “reflected” sound using a different technique. The Delay effect is based on a simple algorithm made of two independent mono delay lines.

Control	Values	Description
Delay	0 - 20000 ms	Defines the amount of time to delay the signal. Default is 250 ms.
Feed-back	0% - 100%	Defines the number of times to repeat the signal. Default is 15%.

Control	Values	Description
Gain	-96 - 0 dB	Default is -12 dB.

Reverb

The Reverb effect simulates a physical environment, such as a gymnasium, cathedral, or valley, that is different from the physical environment of the original recording. In a physical environment, the way we hear sound is based on the properties of direct sounds and reflected sounds. Direct sounds are the frequencies that reach the ear straight from the audio source. Reflected sounds are frequencies that reach the ear after being reflected from a physical surface, such as a wall or mountain side.

Direct sound is an indicator of the proximity of the audio source. For example, if you close your eyes as a car passes, you can estimate its distance based on the level of sound you hear as it goes by. Reflected sounds are the indicators for the physical environment. For example, in a small room, sound is reflected back to your ear more quickly than in a large room. The time it takes for the reflected sound to reach your ear can give you an idea of the size of room you are in. As well, different surfaces and materials have different reflective properties for sound. The more reflective a surface, the more reverb will occur.

By modifying the Predelay, Decay Rate, and Damping values, you can simulate physical environments. You can take a recording that was recorded in a small room with little reverb and make it sound like it was recorded in a large room, such as an arena or church. Different types of music tend to sound best with reverberation times appropriate to their characteristics.

Control		Description
Predelay	1 ms - 200 ms	Defines the predelay for the reverb effect. This determines the delay between the original sound and the first echo. Default is 25 ms.
Decay Rate	0% - 100%	Defines how fast the reverberation decays. Default is 40%
High Cut	0% - 100%	Defines the amount of high frequencies that are filtered out from the reverb effect. This can make the result sound more natural. Default is 0.1%
Damping	0% - 100%	Defines the rate at which high frequencies are dampened as the reverberation decays. Default is 40%

Control		Description
Diffusion	0% - 100%	Defines the density of echoes in the reverberation. Default is 100%.
Output Gain	-96 - 0 dB	Default is 0 dB.

Adjusting Settings on the Auxiliary Effects Desk

Auxiliary effects such as Modulation, Delay, and Reverb can be applied to any number of audio segments. Settings for Auxiliary effects can be adjusted through the Auxiliary Effects Desk menu.

To adjust settings for an auxiliary effect:

- 1 Ensure that the Auxiliary Effects Desk is enabled.

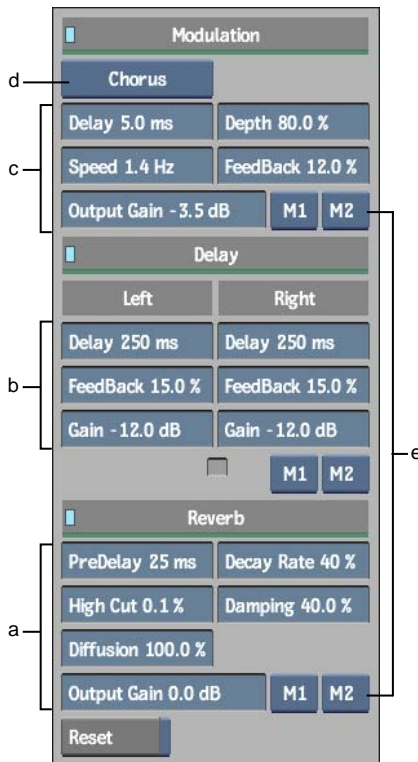

(a) Reverb Effect controls (b) Delay Effect controls (c) Modulation Effect controls
 (d) Modulation Effects option box (e) Output Channel Selection buttons

- 2 If you are adjusting settings for a Modulation effect, select the desired effect from the Modulation Effects option box.
- 3 Adjust the settings for the desired effects as needed.
 For a description of the effects and their settings see [About Auxiliary Effects](#) on page 1241.

Using Output Strips

You can use the output strips to control the gain or limit the peaks of the audio output signals.

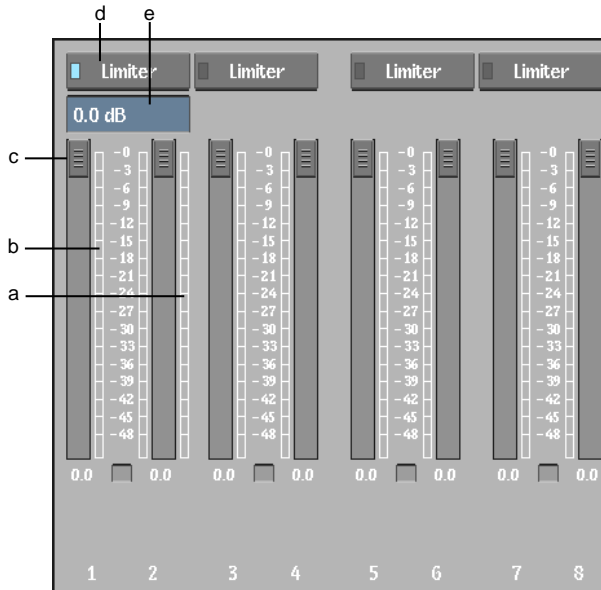

(a) Limiter meter (b) Output meter (c) Gain Level fader (d) Limiter button (e) Limiter Level box

Adjusting Output Strip Gain

Use the output strip faders to control the audio output levels. You can adjust the faders while playback is stopped, or during playback to get a dynamic update of audio levels.

To adjust the audio output strip gain:

- 1 In the AudioDesk, ensure that each audio input strip that you want to work with is assigned to an output strip.
- 2 Toggle the meters to Desk Outputs.
- 3 Play the clip.
The audio output levels are displayed on the meters.
- 4 Click the fader for the output strip that you want to adjust and drag it to the new level.
You can also adjust the levels with the playback stopped.

Using the Limiter

The Limiter provides a form of signal compression. It allows audio signals below a set value to pass unaffected, and clips off the peaks of stronger audio signals that exceed the set value. The audio remains untouched unless the limiter is working, in which case only gain is affected. The built-in auto-release mechanism allows for fast recovery, minimizing distortion and pumping. The Limiter is a stereo effect that applies to a pair of output strips.

To set the limiter:

- 1 In the AudioDesk, ensure that each audio input strip that you want to work with is assigned to an output strip.
- 2 Toggle the meters to Desk Outputs.
- 3 Play the clip.
- 4 Note the audio output levels displayed on the meters.
- 5 Enable the Limiter button.
The Limiter meter appears.
- 6 Adjust the Limiter level to remove any overloads, or to limit the peaks to a desired output level.

Using the Audio Tools

You can perform additional audio functions using the Audio Tools menus in Flame. You can create an audio-only clip containing tone or silence, apply an audio timewarp, copy the audio to another clip, or mixdown the audio to fewer tracks.

Creating an Audio Tone Clip

You can create an audio-only clip containing up to eight audio tracks of silence, or audio tone at the frequency and level that you specify. Audio Tone clips appear with waveforms in their proxies in the clip library and on the Desktop. You can record out the audio tone clip to tape to ensure that the audio levels are adjusted correctly.

To create an audio tone clip:

- 1 From the Main menu, select Editing.
- 2 From the Editing menu, select Audio Tools.
- 3 From the Audio Tools box, select Tone.

The Tone options appear.

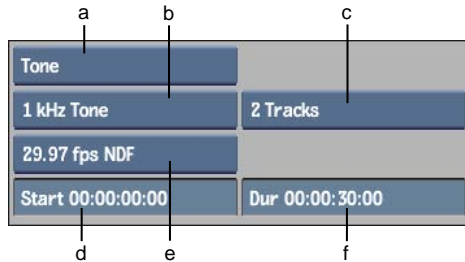

(a) Audio Tools box (b) Frequency box (c) Audio Tracks box (d) Start Time field
(e) Timecode mode box (f) Duration field

- 4 Select the frequency.

NOTE Selecting Silence will still create an audio clip, but the audio track(s) will have a flat waveform at -infinity dB.

- 5 Select the timecode mode.
- 6 Set the start time in the Start Time field.
- 7 Set the duration in the Duration field.
- 8 Select the number of audio tracks. There will be one tone for each track.
- 9 Select the destination.

Audio-Tone clips are displayed with waveforms in the proxy.

About the Audio Timewarp Options

Use the Audio Timewarp options to customize the timestretch of an audio segment. The Audio Timewarp options appear as follows:

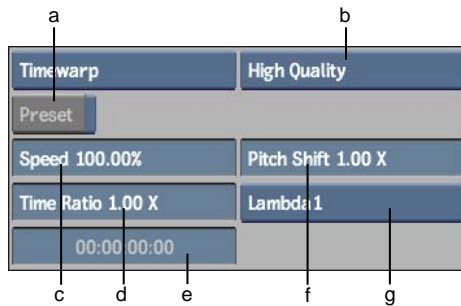

(a) Preset button (b) Quality Factor box (c) Speed field (d) Time Ratio field (e) Duration field (f) Pitch Shift field (g) Time/Frequency Localization button

Audio Timewarp options are described as follows:

Preset button Enable to timestretch the audio based on the difference in frame rates of the source and destination video standards.

Speed field Change the speed and duration of the audio clip based on a speed percentage. The values in the Time Ratio and Duration fields change automatically as you modify the speed percent.

Time Ratio field Change the speed and duration of the audio clip by setting a time ratio. This is the ratio of the number of samples in the result divided by the original number of samples. The values in the Speed and Duration fields change automatically as you modify the Time Ratio.

Duration field Change the speed and duration of the audio clip to create a destination clip with the required duration. The values in the Speed and Time Ratio fields change automatically as you modify the duration.

Pitch Shift field Change the pitch of the audio clip. Leave this option set to 1.00 X to keep the audio pitch constant when applying the timestretch. This is the ratio of the shifted frequency values divided by the original frequency values. (A Pitch shift value of 2 shifts one octave up; a Pitch shift value of 0.5 shifts one octave down.)

Quality Factor box Select the quality of the resulting audio. This can be set to Quick, Standard, or High Quality mode. Use a lower quality mode to experiment with different settings, and then use High Quality to process the final result.

Time/Frequency Localization button Select a time/frequency localization option that suits your audio material:

Select:	To:
Lambda1	Ensure full time localization. This is suitable for single-instrument tracks and voice-over.
Lambda2	Set higher time localization and lower frequency localization. If applying Lambda1 results in an echo effect, this could be a better option.
Lambda3	Set the time/frequency localization in mid ranges of time and frequency domains. This is the best general-purpose setting.
Lambda4	Set higher frequency localization and lower time localization.
Lambda5	Ensure full frequency localization. This is suitable for multi-instrument tracks, such as classical music.

Applying an Audio Timewarp

Use Audio Timewarp to timestretch an audio segment. With Audio Timewarp you can change the speed and duration or the pitch of the audio. Audio Timewarp uses the DIRAC Time Stretching and Pitch Shifting Technology developed by DSP Dimension (www.dspdimension.com). Depending on the amount of timestretch applied, this soft effect may degrade the quality of the resulting audio.

If you are converting video material to a different frame rate, you can apply a slight Audio Timewarp to the audio to keep it in sync with the video. For example, when you convert the video frame rate from 24 fps to 25 fps, you will need to increase the speed and duration of your audio while preserving the pitch. Presets are available for this purpose.

To apply an audio timewarp from the menu:

- 1 From the Main menu, select Editing.
- 2 From the Editing menu, select Audio Tools.
- 3 From the Audio Tools box, select Timewarp.

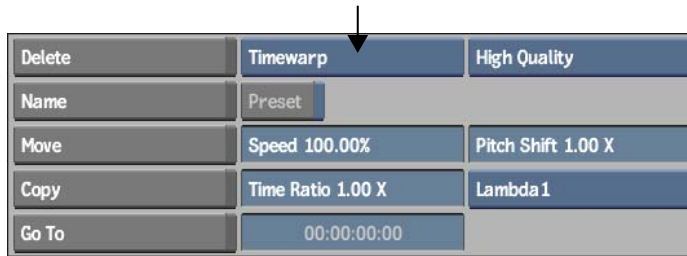

The Audio Timewarp options appear.

- 4 Select the clip with audio that you want to timestretch.
- 5 Adjust the Audio Timewarp parameters.
See [About the Audio Timewarp Options](#) on page 1249.
- 6 Select a destination.
A new clip containing the timestretched audio is added.

Converting Audio between Different Video Standards

When you convert your material between different video standards, your audio falls out of sync due to the change in the video frame rate. To avoid this, use the Preset option to timestretch the audio based on the difference in frame rates of the source and destination video standards.

To convert audio between different video standards:

- 1 Open the Audio Tools menu and, from the Audio Tools box, select Timewarp.

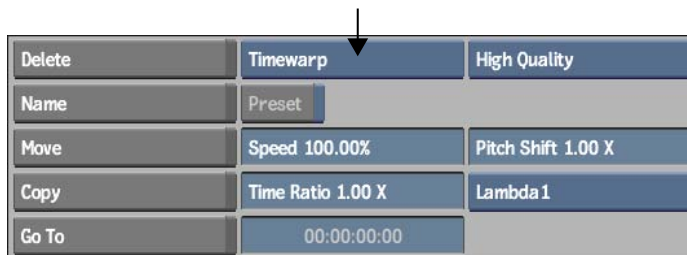

- 2 From a reel, select a clip that requires audio timestretching.
- 3 Enable Preset.

The Timewarp Preset options appear.



(a) Preset button (b) Source Frame Rate box (c) Destination Frame Rate box
(d) Time Ratio field

The Source Frame Rate box shows the current frame rate of the selected clip.

- 4 From the Destination Frame Rate box, select the required value.
The conversion value appears in the Time Ratio field.
- 5 Click in the upper-left corner of the clip to start conversion.

Mixing Down Audio

If you applied changes such as EQ, pan, or gain adjustments to audio tracks in the AudioDesk, and you want to export the clip with these changes, you need to mix down the clip prior to exporting it. It is not necessary to mix down audio prior to output to a VTR. However, if your audio tracks contain a lot of edits, and you notice dropped frames on playback, output may be smoother if you first mix down the clip.

Use the Audio Mixdown tool to mix down your audio with the current AudioDesk output strip assignments, to four channels, to stereo, or to mono. All soft effects such as dissolves, fades, and audio soft effects made to audio anywhere in the application are processed during mixdown. All current AudioDesk and EQ settings are also applied to the mixdown clip.

You can generate an audio-only mixdown clip, or you can generate a mixdown clip with all the clip's video tracks. You can also mixdown audio on export.

To mix down audio:

- 1 Make sure that you have assigned the audio tracks that you want to mix down to the appropriate channels. See [Assigning an Audio Track to an AudioDesk Input Strip](#) on page 1205.
- 2 From the Editing menu, select Audio Tools.
- 3 From the Tools box, select Mixdown.

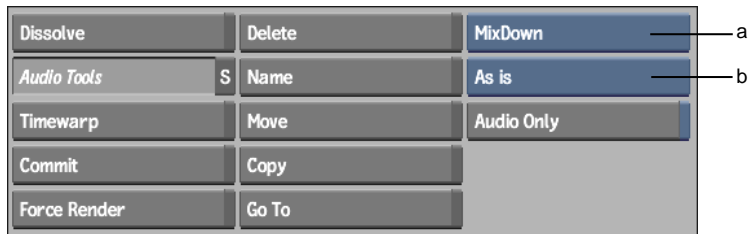

(a) Tools box (b) Mixdown option box

- 4 From the Mixdown option box, select one of the following options.

Select:	To mix down:
As Is	Mix down with the current output strip assignments. This option is recommended for the purpose of exporting or outputting the clip. See Using Output Strips on page 1246.
To 4 tracks	Mix down to four tracks. The output strips are assigned sequentially in fours to the mixed-down channels (where M1 goes to 1, M2 to 2, M3 to 3, M4 to 4, M5 to 1, and so on)
To Stereo	Mix down to two tracks. The output strips are assigned sequentially in twos to the mixed-down channels (where M1 goes to 1, M2 to 2, M3 to 1, M4 to 2, and so on).
To Mono	Mix down to one track.

For all options, the AudioDesk levels and EQ settings are applied to the mixed down clip.

- 5 To generate an audio-only clip, enable Audio Only.
- 6 Select the clip that you want to mix down.
The pan faders are reset to the full channel.

7 Select the destination.

A new clip containing the processed audio is added to the destination reel.

The tracks are mixed down. The output strip assignments and pan settings of the destination clip are set to their default values.

Copying Audio to Another Clip

You can copy the audio tracks of one clip to another clip. When you copy the audio, you can choose how the audio tracks are handled in the record clip. The new audio tracks can overwrite the audio tracks in the record clip or get appended to them as additional tracks, up to a maximum of 32 audio tracks.

To copy one or both audio tracks to another clip:

- 1 From the Format menu, select Copy.



- 2 From the Copy option box, select Audio.

The Overwrite/Append button appears.

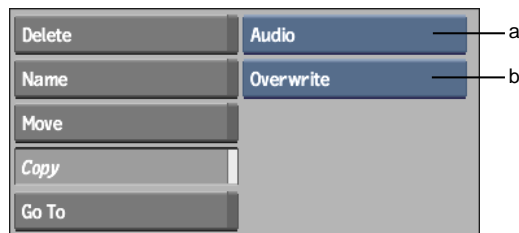

(a) Copy option box (b) Overwrite/Append button

- 3 Toggle the Overwrite/Append button as needed.

Select:	To:
Overwrite	Overwrite the audio tracks in the record clip with those of the source clip.
Append	Append the audio tracks in the record clip with those of the source clip, up to a maximum of 32 audio tracks.

- 4 Select the source clip.
- 5 Select the record clip.
The audio tracks are copied to the record clip.

Part 9: Batch Processing

Part 9 includes these chapters:

- [Batch Overview](#) on page 1259
- [Batch Processing](#) on page 1283
- [Batch: Node Reference](#) on page 1329
- [Batch FX](#) on page 1375

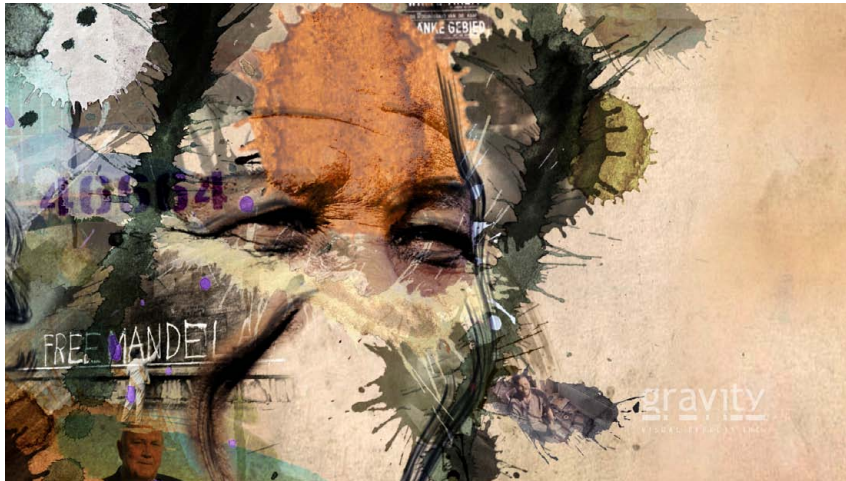

Images courtesy of Gravity Visual Effects Canada

Batch Overview

49

Topics in this chapter:

- [About Batch](#) on page 1259
- [Batch Workflow](#) on page 1262
- [Accessing the Batch Menu](#) on page 1262
- [Viewing the Batch Schematic](#) on page 1267
- [Accessing Modules from Batch](#) on page 1272
- [Creating Animations with the Batch Universal Editor](#) on page 1273
- [Offsetting Clips with the Timing View](#) on page 1274
- [Using the BFX View](#) on page 1278
- [Setting Batch Preferences](#) on page 1278

About Batch

Use Batch to assemble a series of tasks, such as colour correction, keying, and multilayer composites with animation, where the result of each task serves as the source for the next one.

Working in Batch requires the building of a process tree. Clips and nodes form the fundamental structure of a Batch process tree. The Batch module is designed to facilitate inter-module workflow and quicken interactivity as you create effects.

Each task—colour correction, keying, compositing—is represented as a node in Batch, which you arrange in the process tree. By building a process tree of nodes and clips, you eliminate the waiting time required for desktop renders and you save disk space since these intermediate results are not stored.

A Universal Channel Editor allows you to change parameters for any module at any time. A timeline makes editing functions, transitions, and timewarps available directly in Batch. Multiple view functions allow you to see changes in-context, making experimentation easier. Also, proxy processing increases performance when working with high-resolution footage by replacing it with a low-resolution version.

Any clip in Batch can be selected for editing in the Batch schematic. You can make additional changes to the individual timeline of a clip, and create and update Batch FX on the Batch timeline.

Batch Concepts

The following terms and concepts are used throughout the Batch chapters to describe workflow and the user interface.

Clips

Clips are a sequence of images or frames loaded from an external device such as a VTR, stored in digital format, and displayed in the clip library and on the Desktop. Clips form the root element of a process tree.

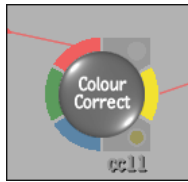

Image courtesy of The Post Group

Nodes

A node is a graphical representation of a function or module that affects a clip or another node in the process tree. Nodes have one or more input points

(also called tabs) in order to connect clips to them. For example, a Colour Correct node can accept a Front, Matte and Back connection, whereas an Output node accepts a video and audio input.



Process Tree

A process tree is the structure of clips and nodes that ultimately creates an effect. Clips are connected to nodes, and in turn, nodes can be connected to more clips or other nodes. A process tree ends with an Output, BFX Output, or Export node.

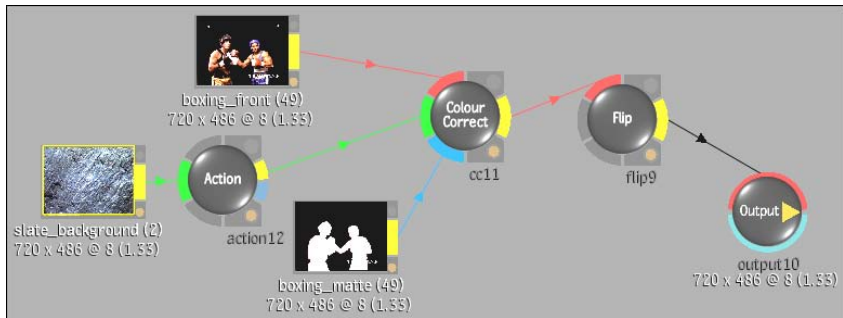

Images courtesy of The Post Group

Rendering

Rendering is the process of generating the final clip or an intermediate result. When rendering in Batch all process trees in the schematic are processed, and one clip is written to the destination specified by each Output node, BFX Output node, or Export node.

Batch Workflow

The following table outlines the typical Batch workflow from selecting clips to rendering.

Step:	Refer to:
1. Bring clips into Batch.	Accessing the Batch Menu on page 1262.
2. Edit clips directly or from their history.	Modifying Clips in Batch on page 1288 and Clip History on page 807.
3. Resize a clip.	Resize Settings on page 681
4. Assemble a process tree.	Assembling a Process Tree on page 1283 and Batch: Node Reference on page 1329.
5. Work across modules.	Accessing Modules from Batch on page 1272.
6. Edit Batch FX.	Editing Batch FX on page 1409.
7. Define an output or export.	Outputting and Exporting Batch Results on page 1322.
8. Output a result.	Outputting and Exporting Batch Results on page 1322.

Accessing the Batch Menu

Use the Batch menu to set up a process tree, load clips, and set rendering options. The Batch menu is available when you enter Batch and at every Batch FX level. You can enter Batch directly, or select clips to work with inside Batch. For more information on bringing a segment into a Batch FX level, see [Creating Batch FX](#) on page 1376.

To access the Batch menu:

- 1 In the Main menu, click Processing.
- 2 In the Processing menu, click Batch.
- 3 Select a destination reel on the desktop.

The Batch menu appears with the last used schematic, if any, on the desktop. Alternatively, to open Batch with an empty schematic, hold **Alt** while selecting a destination reel.

To access the Batch menu with clips:

- 1 In the Main menu, click Processing.
- 2 Hold down the **Ctrl** key and click Batch.
The cursor changes to a red arrow to select a clip.
- 3 While holding down the **Ctrl** key, select as many clips as you want.
- 4 Release the **Ctrl** key, and then select the last clip.
The cursor changes to a white arrow.
- 5 Click a destination reel.

The Batch menu is displayed and all the clips you selected from the desktop are displayed in the Batch schematic.

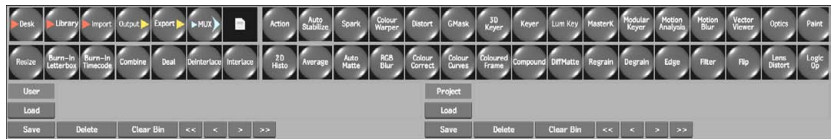

Node bins and custom node panels

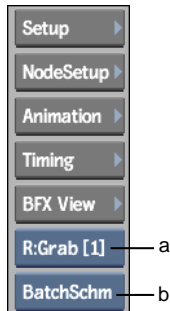

(a) View box (b) Reference box



Process Tree controls

The Batch controls are described as follows.

Setup button Displays Batch setup options.

Node Setup Displays the selected node's Setup menu.

Animation button Displays the Universal Channel Editor. You can also access the large view of the Channel Editor by tapping the right swipe bar. See [Accessing the Channel Editor](#) on page 1964.

Timing Displays the relative position in time of all Batch clips. See [Offsetting Clips with the Timing View](#) on page 1274.

BFX View Displays a schematic view of all Batch FX applied to a BFX segment.

Reference box For the currently selected node, displays one of the following in the reference portion, “R” side, of the split bar.

Select:	To display:
Front	The front of the currently selected node.
Back	The back of the currently selected node.
Matte	The matte of the currently selected node.
Result	The result of the currently selected node.
Context1	The result your changes to a node have on a node set as context1 further along in the process tree. See Viewing Nodes in Context on page 1315.
Context2	The result your changes to a node have on a node set as context 2 further along in the process tree.
Out Matte	The matte that will be output.

Select:	To display:
Reference	The reference frame when the split bar is enabled.
Grab	The reference frame(s) stored in the reference buffer when the split bar is enabled.
Source Clip	The source focus clip.
Record Clip	The record focus clip.

To see the reference image, select Split in the View menu. The other side of the split bar is determined by the view you select from the View box. See [Displaying the Reference Area](#) on page 131.

View box Sets the view in the image window. Available views are determined by the active node. You can also use the following hot keys to display commonly used views.

Select:	To display:
Front (F1)	The front of the currently selected node.
Back (F2)	The back of the currently selected node.
Matte (F3)	The matte of the currently selected node.
Result (F4)	The result of the currently selected node.
Channels (F5)	The Universal Channel Editor.
BatchSchm (Esc)	The Batch schematic. The hot key acts as a toggle between the Batch schematic and the current view.
Node Schematic (~)	The schematic for the selected node. (Only visible when an Action, Gmask or Distort node is selected.)
Out Matte	The matte that will be output.
Reference	The clip stored in the reference buffer.
Context1 (1)	The node for which context 1 is set.
Context2 (2)	The node for which context 2 is set.
C: Main Level	The Clip results at the main timeline level. This option appears when you enter Batch FX.

Select:	To display:
C: Level-up	The clip results one level higher than the current Batch FX level. This option appears when you enter a second level Batch FX.
Tracks	The in and out times, duration, and keyframe information of animation channel parameters.
Info	Animation channel parameter information in tabular format.
Source Clip (F7)	The source focus clip.
Record Clip (F8)	The record focus clip.

Save button and box Save a Batch setup by selecting one of the following.

Select:	To save:
All	All nodes in the schematic.
Selected	Selected nodes.

By default, Batch setups have the file extension *.batch*.

Load button and box Load a Batch setup by selecting one of the following.

Select:	To:
Replace	Replace the current Batch setup in the schematic.
Append	Append the selected setup to the current Batch setup in the schematic. If the setup contains nodes that have the same name as the current Batch setup, the conflicting nodes in the current schematic are renamed.

Loading a Batch setup also loads the clips used in the process trees. If Batch cannot find a clip, it displays the name of the clip in red.

You can load Batch setups that contain Flame and Inferno specific nodes. These nodes—called render-only nodes or non-editable nodes—cannot be modified in Flame; however, Batch processes the node operation in the final clip result.

Node bins Contain all the nodes you require to build a process tree. The bars are divided into four categories: input and output nodes, formatting nodes, effects nodes, and processing nodes. See [Batch: Node Reference](#) on page 1329.

Custom node panels Contain custom nodes that you have created. The left panel contains custom nodes available to the user, and the right panel contains custom nodes available to the project. See [Creating Custom Nodes](#) on page 1309.

TIP Press **Ctrl+Tab** to return to the node bins from any module's menu.

Process Tree controls Use these controls to position and adjust Batch nodes to keep track of processing directions. See [Manipulating Nodes](#) on page 1298.

Viewing the Batch Schematic

Visual cues in the Batch schematic are designed to help differentiate clips from one another. In addition, detailed information is available for each clip.

Clip Information

In order to distinguish similar clips from each other, you can display clip information such as resolution, frame rate, and size.

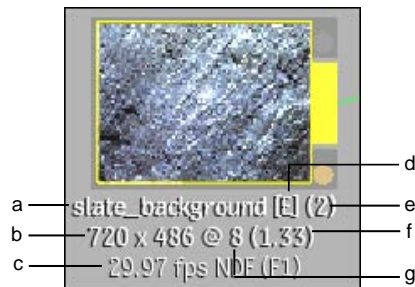

(a) Clip name (b) Size (c) Frames per second (d) Indicates edited clip (e) Number of frames (f) Aspect ratio (g) Frame bit depth

To display clip information:

- 1 In Batch, click Setup.
- 2 Select one of the following from the Clip Info box.

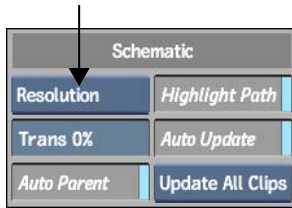

Select:	To display:
Resolution	The clip's name, number of frames, dimension, frame depth, and aspect ratio.
Size	The clip's name, number of frames, and dimension (in pixels).
Framerate	The clip's name, number of frames, and number of frames per second (fps).
Size+Rate	The clip's name, number of frames, dimension (in pixels), and number of frames per second (fps).
Resolu- tion+Rate	The clip's name, number of frames, dimension, frame depth, aspect ratio, and number of frames per second (fps). This is the most detailed level of clip information.
No Info	No information except the clip name and number of frames.

Visual Cues

When working in the Batch schematic or in the timeline, clips can adopt symbols or letters that identify them as having been edited. Also, if the clip has a history list, this is identified by the letter H appearing next to the clip name.

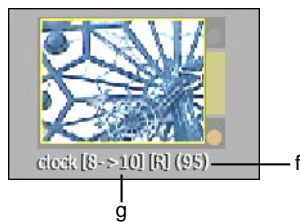
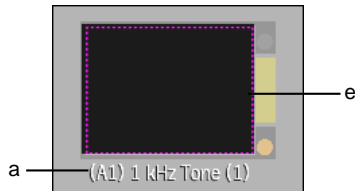
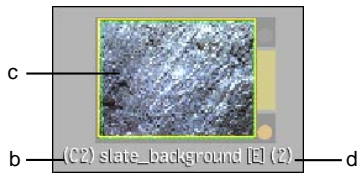

(a) (A) symbol (b) (C) symbol (c) Context outline (d) [E] symbol (e) Audio Context outline (f) [R] symbol (g) LUT symbol

[E] symbol Signifies that the clip has been edited in the Batch timeline. In addition, the clip name is coloured blue denoting that the clip can be found in the clip library.

(A) symbol and Audio Context outline Signifies that an audio context has been set for this clip or node. In addition to the A, the clip had a dotted purple outline. The letter A is followed by the number of the context, for example, A2 is the second Audio context. See [Working with Audio Contexts](#) on page 1317.

(bfx) symbol Signifies that the segments that comprise the clip have different sets of Batch FX operations applied to it. The clip cannot be expanded in the schematic. See [Soft Effects](#) on page 1111.

(BFX) symbol Signifies that a Batch FX operation was applied to the segments. The clip can be expanded in the schematic.

(C) symbol and Context outline Signifies that a context has been set for this clip or node. In addition to the C, the clip had a dotted green outline. The

letter C is followed by the number of the context, for example, C1 is the first video context. See [Viewing Nodes in Context](#) on page 1315.

(H) symbol Signifies that the clip has had an effect or process applied to it. The clip's history can be expanded into a process tree and edited. See [Clip History](#) on page 807.

(h) symbol Signifies that the clip — or soft clip — has been edited and contains at least one viewable and editable history segment. See [Clip History](#) on page 807.

[R] symbol Signifies that a Resize has been applied to the clip. See [Resizing in Batch](#) on page 668.

LUT symbol Signifies that a LUT is being applied to the clip. The first and second number represent the source and destination bit depths, respectively. See [Accessing the LUT Editor in Batch](#) on page 748.

Viewing the Batch Schematic Work Area

You can enable a schematic navigator that provides a big picture of all the nodes in the work area. The navigator appears as a mini-map of all nodes, and contains a thin, grey rectangle showing the current view area.

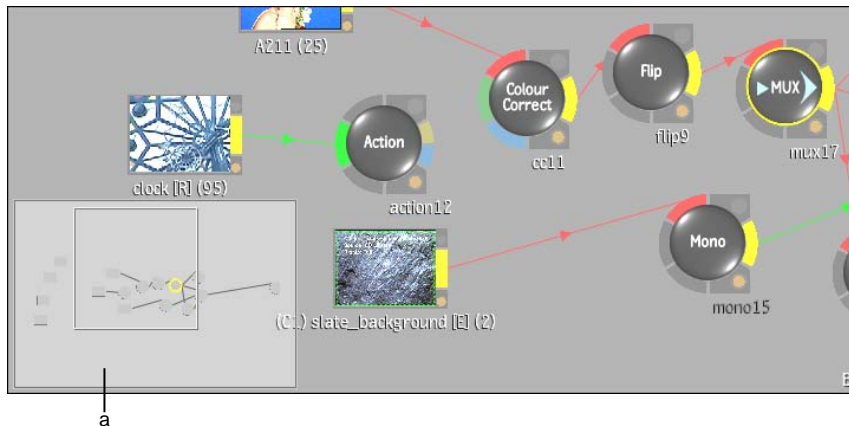

(a) Schematic navigator

To move in the Batch schematic view using the navigator:

- 1 Press **Ctrl+Alt+N**.
The navigator appears.

- 2 From the Batch Setup menu, click an area in the navigator to move the current view to that area of the schematic work area.
- 3 **Alt**+click to move the navigator window within the schematic work area.

Batch Schematic Notes

You can add notes to a node or group in the Batch schematic. Notes are useful when collaborating on an effect or project with other users. Notes are saved with the setup so they are visible to all. You can copy and paste content between notes.

To add a note to the Batch schematic or a node:

- 1 In Batch, display the node bin.
- 2 Drag and drop the note icon anywhere in the Batch work area.
- 3 Double-click the note icon.
The Note text editor appears.
- 4 Type text into the Note field.
Entered text will identify the user and date of entry.
- 5 Click Exit Note or press **Ctrl+Enter** to exit the Note text editor.

Copying and Pasting Content

You can use the standard hotkeys to cut, copy, and paste the content of notes. Use the following controls.

Use:	To:
Ctrl+A	Select all of the content in a note.
Ctrl+C	Copy the selected content.
Ctrl+V	Paste the copied content.
Ctrl+X	Delete selected content.

Viewing Schematic Notes

You can view notes or modify how they are displayed in the schematic work area.

To adjust a note's display settings:

- 1 In the schematic work area, use one of the following commands.

Use:	To:
V+roll over note	Temporarily display a clip or node's note beneath the cursor.
Shift+V	Expand a clip or node's note beneath the cursor.
Click X (upper-left corner of note)	Close the note in the schematic.

Multiple Viewports

You can display up to four viewports at a time in the image window, including a view of the Universal Channel Editor and the Batch schematic. Multiple viewports are convenient for setting channel values, working in Schematic view, and previewing your results all at the same time without having to switch views. See [Displaying Multiple Views](#) on page 136.

Accessing Modules from Batch

Many modules are fully integrated into Batch to improve workflow. User interface controls are quickly accessible for all modules. In addition, you can access a specific module's Setup menu for the following nodes:

- Action
- Colour Correct
- Colour Warper
- Gmask

You can access these Setup menus by selecting the Node Setup menu button. Clicking another node while the Node Setup is active will display its Setup menu.

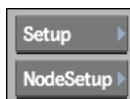

To access the module menu in Batch:

- 1 Disable the Setup menu button.
- 2 Select the module node from the Batch schematic.
The module's respective menu appears.
- 3 Tap the left swipe bar to return to the Batch schematic.

Working in Action

You can access all of Action's functionality from Batch. Import clips, create media, and add effects using the Action node in the Batch process tree. You need not leave the Batch environment to accomplish any Action-related task.

Note the following when working in Action from Batch:

- To show the selected node's schematic, press the ~ key. Press ~ again to switch between the schematic and the reference area.
- To return to the Batch schematic, press the **Esc** key.
- To add Media nodes to an Action node, **Ctrl**-click the Add button in the Action Media list. If empty media or <new media> is selected, an empty Media node is created. If media already has clips from the desktop, the Media node and the Batch clip(s) are created and linked together. If the selected media is already a Media node, nothing happens.

For more information, see [Action Node](#) on page 1333.

Creating Animations with the Batch Universal Editor

Use the Batch Universal Channel Editor to create animations for each node and then synchronize the timing of animations across colour correction, keying, compositing, and other nodes in Batch. Channels in the Universal Channel Editor include most nodes present in the Batch schematic. See [Creating Animation Sequences Across Nodes in Batch](#) on page 2029.

Furthermore, use expressions to create complex animation effects where, for example, the position of the media's axis in the Action node is affected by the position of a vertex for a garbage mask. See [Working with Expressions in the Channel Editor](#) on page 2043.

To access the Universal Channel Editor:

- 1 Do one of the following:
 - Tap the right swipe bar.
 - Select Channels from the View box.
- 2 Click Animation to access the Animation controls.

Offsetting Clips with the Timing View

Use the Timing View to display the relative position of Batch clips in time. You can perform basic editing operations on segments, such as offsetting clips and trimming segments within a clip as you would in the timeline. Timing View can be accessed from any Batch FX level or from the main Batch timeline. It allows you to view timing information of all clips in the current level at once and adjust the timing of clips.

Use the Timing View to select a Batch clip to slip, slide, or trim. You can also move a segment within a clip (but not between clips).

Edit a clip gesturally or use hot keys as you would on the record timeline. See [Trimming Shots](#) on page 1045.

To access the Timing View:

- 1 In Batch, click Timing.

The Timing View appears. All clips in the current Batch schematic are represented in the Timing View by a clip proxy and primary video track. Gaps are displayed based on No Media settings, which are set in the clip's Basic menu in Batch.

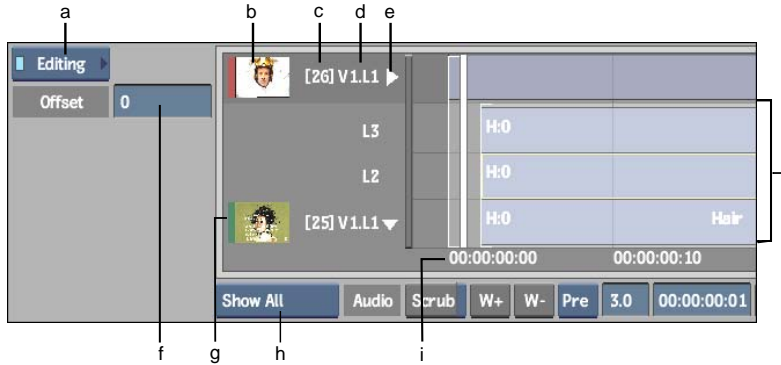

(a) Menu Priority box (b) Batch clip proxy (Record clip, red) (c) Clip number (d) Track and layer number (e) Expand/Collapse button (f) Offset field (g) Batch clip proxy (Source clip, green) (h) Filter button (i) Frame/timecode number (j) Track

Images courtesy of Das Werk and The House

Batch clip proxy Represents the clip associated with the track. The Source and Record clips are indicated by a proxy with a green and red bar, respectively. Select a clip's Batch timeline to set it as the Source or Record Focus. Double-click a clip proxy to display its Batch timeline.

Clip number Displays the number assigned to the Batch clip when it is brought into Batch. Each track displays the corresponding clip number in square brackets. This number indicates the order in which clips were brought into Batch and allows you to differentiate similar clips.

Track Each clip in the Timing View is represented by its primary track. If the track has multiple layers, the display can be expanded to show all layers, or collapsed to display only the focus layer.

The primary track is set in the clip's timeline. See [Patching Video and Audio Channels](#) on page 997.

Filter button Limit the type of clips that are displayed in the Timing View.

Select:	To:
Show All	Display all clips in the Batch schematic.
Show Tree	Display all clips in the selected processing tree.
Show Branch	Display all clips in the current node branch.

Select:	To:
Show Selected	Display all clips and nodes selected in the Batch schematic.

Swipe bar Alternate between the standard view and a larger Timing View by holding down the **Ctrl** key as you swipe.

Frame/timecode number Displays time values. Change time settings in the General section of the Preferences menu.

Selecting Clips and Segments

You can select clip proxies and segments separately in the Timing View.

To select a clip in the Timing View:

- 1 Do one of the following:
 - Click the clip proxy in the Timing View.
 - Press **Ctrl** and click clip proxies in the Timing View to select multiple clips.
 - Click the lower left corner of the Timing View to select all clips.

The clip's proxy and track in the Timing View are highlighted by an orange bounding box.

Select a segment by clicking on it in the Timing View. When you select a segment in a track, it is highlighted in yellow.

Different types of selections can occur simultaneously in Timing View. You can select a segment and you can select a clip. The segment selection can be in a different clip than the clip selection.

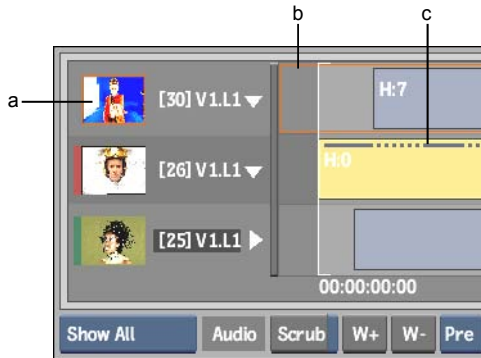

(a) Proxy of selected clip (b) Clip selection (c) Segment selection

Image courtesy of Das Werk and The House

Offsetting Clips

Adjust the timing of clips by offsetting them in the Timing View. When you offset a clip, you simultaneously offset all of its segments on each layer. Multiple clips can be offset simultaneously.

You can view the timing of all clips in the current Batch schematic

To offset a Batch clip:

- 1 Click the clip proxy.

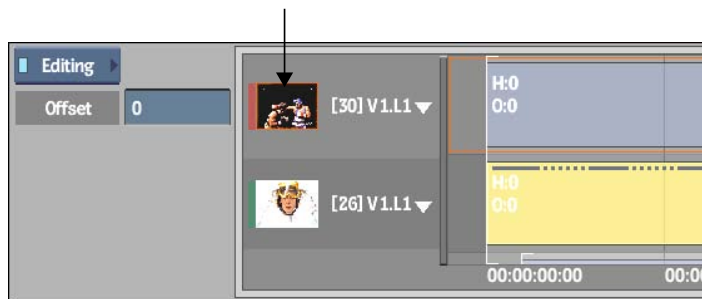

Image courtesy of Das Werk and The Post Group

NOTE To select multiple clips, **Ctrl-click** subsequent clip selections.

A bounding box highlights the track.

- 2 In the Offset field, set the value to adjust the number of frames by which the clip should be offset. If you offset multiple clips simultaneously, the value is reset to 0 once the offset is complete.

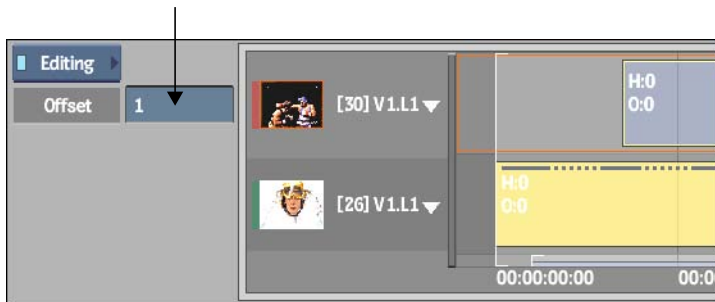

Image courtesy of Das Werk and The Post Group

Using the BFX View

The BFX View displays a schematic of all Batch FX applied to a BFX segment. You view a single representation of Batch FX on different levels, allowing you to navigate the BFX View to access a complete Batch setup relative to the main Batch timeline. You can match a source clip in BFX View when you are at a different Batch FX level than the source clip.

See [Navigating Batch Setups](#) on page 1410.

Setting Batch Preferences

Use the Batch Setup menu to enable Batch log files, set timeline, schematic, and undo properties, and manage caching of rendered frames.

To access the Setup menu:

- 1 In the Batch menu, click Setup.

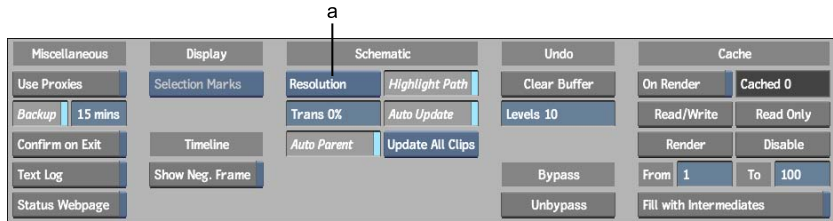

(a) Clip Info box

The Batch Setup controls are described as follows.

Clips to Reel button Copies clips in a Library node to the desktop reels.

Use Proxies Replaces clips with proxies when working in Batch and all associated modules. When enabled, the image window is outlined in amber. See [Using Proxies in Batch](#) on page 1286.

NOTE It is possible that you lose precision when replacing your clips with proxies. Because they are converted to 8 bits, images may degrade.

Backup button and field Create a backup copy of your current Batch setup automatically. When enabled, a backup copy of the current setup is saved in the `_session.batch` file in the `batch` directory.

In the Backup Frequency field, set the number of minutes between backups.

Confirm on Exit button Prompts for a confirmation before exiting Batch.

Text Log button Saves Batch processing status information in a text file called `batch_log`. These files are located in `/usr/discreet/project/<project home>/batch/log`.

Information is appended on a continuous basis to this file and serves as a permanent log file as long as Text Log is enabled.

Status Webpage button Creates three HTML files called `batch_log.html`, `batch_log_status.html`, and `index.html`, when enabled. These files are located in `/usr/discreet/html`.

The `batch_log.html` file describes the user, project, and date of the current job.

The `batch_log_status.html` file is the actual status of the Output or Export node being processed and includes information such as remaining processing time, the frame currently being processed, and the number of frames to process.

The *index.html* file combines the contents of both the *batch_log* and the *batch_log_status* files into a single file.

A message is displayed if an Output node is skipped at process time. This node will be skipped if the host where the output is wired is unreachable or if the library is read-only.

The contents of the HTML file are cleared after each Batch process.

Selection Marks box Displays the cue marks and in and out points of either the selected clip, source clip only, or record clip only.

Show Negative Frame button Displays negative frame numbers in the Current Frame field and the Batch timeline when a segment is offset before Frame 1. Disable to display only frames from Frame 1 onward.

Clip Info button Lets you select whether to display resolution, frame rate, size, or any combination of information in the schematic.

Transparency field Sets the transparency of currently unselected nodes in the schematic.

Auto Parent Enables the Parent and Cut options in the schematic while using the Move edit mode.

Highlight Path button Highlights the path of the currently selected node in the schematic.

Auto Update button Updates a node's result proxy automatically. When you change the current frame, the result proxies are updated for all clips or selected clips depending on what is defined in the Update Clip box.

Update Clip box Defines whether you interactively update all clips or only selected clips in Batch. Choosing Update Sel Clips increases performance.

TIP It is recommended you update selected clips when editing with the timeline.

Clear Buffer button Clears the Undo buffer of all previous undo operations.

Undo Levels field Sets an upper limit for the number of undo or redo operations, which applies throughout the Batch module, including tasks performed in the schematic. Tasks completed with the various nodes in Batch also support multiple undo and redo operations.

Unbypass button Disables node bypassing for selected nodes in the current Batch setup.

On Render button Manages the cache of any frames you render in Batch. See [Caching Frames](#) on page 1319.

Read/Write button Sets cache to read and write status.

Read Only button Sets cache to read-only status.

Render button and From and To fields Renders the cache of selected nodes for the frames defined in the From and To fields.

Disable Turns off caching for selected nodes.

Fill Cache with Intermediates button Fills each node's cache with the intermediate clips contained in the history. If you render a clip in proxy mode, the history is not cached.

Topics in this chapter:

- [Assembling a Process Tree](#) on page 1283
- [Manipulating Nodes](#) on page 1298
- [Previewing Results](#) on page 1313
- [Outputting and Exporting Batch Results](#) on page 1322

Assembling a Process Tree

Use Batch to assemble a series of tasks using nodes. Each node represents a specific Flame function. You connect clips with nodes and use the result of one node as the source for the next node. As you assemble this arrangement in the Batch schematic, you are building a process tree that processes as many output clips as you want. Intermediate clips can be processed as well.

A process tree begins with a clip, contains at least one node, and ends with an Output, BFX Output, or Export node. The following example shows a simple process tree that performs a colour correction using a front, back, and matte clip.

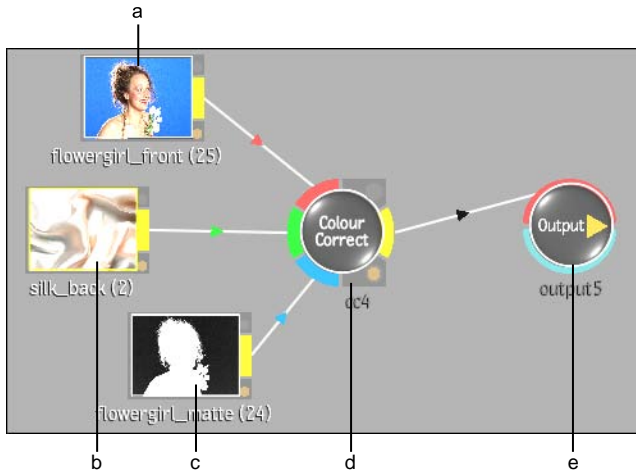

(a) Front clip (b) Back clip (c) Matte clip (d) Colour Correct node (e) Output node

To build a process tree:

- 1 In the Batch menu, select BatchSchm from the View box.

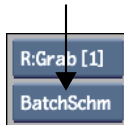

- 2 Add the clips and nodes to the schematic. See [Adding Clips to the Schematic](#) on page 1285, and [Adding Nodes to the Schematic](#) on page 1291.
- 3 Connect the clips and nodes in the required sequence for your effect. See [Connecting Clips and Nodes](#) on page 1292, and [Working with Multiple Connections](#) on page 1296.
- 4 Modify the clips and nodes, as needed, to adjust effect parameters, trim segments, apply LUTs, and adjust audio, for example. See [Modifying Clips in Batch](#) on page 1288.
- 5 Connect a node to a BFX Output, Output, or Export node.

Before you can process, a process tree must end with either a BFX Output, Output, or Export node. Batch uses these nodes to process the result of the process tree to the specified destination in the Queue Manager. See [BFX Output Node](#) on page 1339, [Output Node](#) on page 1365, [Export Node](#) on page 1347, and [Outputting and Exporting Batch Results](#) on page 1322.

- 6 Preview your process tree, then click Process.

The final clip is stored on the Desktop or in a library. See [Previewing Results](#) on page 1313 and [Outputting and Exporting Batch Results](#) on page 1322.

Adding Clips to the Schematic

You can add clips to the Batch schematic in the following ways:

- Use the input nodes to load clips from the Desktop reels or a clip library, or import a clip from a different format.
- Double-click a node's input tab to load clips from the Desktop reels.

When you load or import clips from remote clip libraries, Batch does not duplicate storage on the local framestore. The import process occurs one frame at a time as you jog the timebar. In this way, the framestore is not cluttered with duplicate information.

To add clips to the schematic:

- 1 In the Batch menu, select BatchSchm from the View box.
- 2 Drag one of the following nodes to the schematic.

Select:	To:
Desk node	Add clips from the Desktop reels. You can select up to six clips. Click Exit Clip Select to return to Batch. See Desk Node on page 1346.
Library node	Load clips from a local or remote clip library. Select the clips and click Load to return to Batch. See Library Node on page 1356.
NOTE When creating a Library node for a clip originating from an imported library, the proxy resolution of the remote clip may not match the proxy resolution of the current project. If this occurs, load the remote clip on the Flame first, and then use it in Batch.	
Import node	Import images and clips using the Import Image module. See Import Node on page 1350.

- 3 Select the clips you want to add to the Batch schematic.

4 Click Exit.

You return to Batch and your selected clips are displayed as proxies in the schematic.

NOTE When adding a Cineon® clip to the Batch schematic, an automatic linear gamma conversion to an 8- or a 12-bit image occurs. An OpenEXR clip is stored automatically as a 12-bit image. When adding clips with these file formats, the LUT Editor option is automatically enabled.

To replace a clip in the schematic:

- 1 In the Batch schematic, double-click a clip.
The Desktop appears.
- 2 Select the replacement clip.
- 3 Click Exit Clip Select to return to Batch.
In the Batch schematic, the original clip is substituted for the new selection.

Importing Multiple Resolutions

You can import clips of resolutions other than the default resolution defined for the project. The resolution and aspect ratio display directly on the clip in the schematic. Proxies are also displayed in their correct aspect ratio.

Nodes with multiple inputs, such as the Keyer and Colour Warper, must use clips of the same resolution. For example, the Front and Back inputs must be of identical resolution. If you want to add a clip with a different resolution as an input, you must either parent a Resize node between the clip and the input of the node, or resize the clip itself. For Action nodes, each Action layer must also use a front and matte of the same resolution. However, separate layers can have different resolutions.

Using Proxies in Batch

Use proxies to work with low-resolution versions of your high-resolution material. Using an image's proxy to perform colour corrections, blurs, or other edits significantly increases the interaction speed. Proxies of your clips are generated according to your project settings and conditions.

To use proxies in Batch:

- 1 In Batch, click Setup to display the Batch Setup menu.

2 Enable Use Proxies.



All clips replace their respective proxies as defined at project creation. The image window is outlined in amber.

TIP Press **Ctrl+P** to toggle the Use Proxies button at any time, from any location in Batch.

- 3 If you click Process while in Proxy mode, you are asked to confirm whether you wish to render the proxies rather than the original clips.

Using OpenEXR Images in Batch

OpenEXR-formatted clips loaded from the Flame or imported from the library into Batch.

A selection of Batch nodes supports direct OpenEXR input. See [Batch: Node Reference](#) on page 1329. If a clip is stored at 16 bits and connected to a node that does not support floating point data, its red warning tab is activated. To connect an OpenEXR-formatted clip to a node that does not support OpenEXR input, apply a conversion and export it to a linear format.

In Batch, you can apply a conversion in EXR Display by:

- Connecting the clip to a LUT Editor node
- Accessing the LUT Editor of a clip

You can use a LUT Editor node to apply a conversion to an OpenEXR-formatted clip. If a clip is stored at 16 bits, and you want to connect it to a node that does not support floating point data, you must first attach it to a LUT Editor node to apply a linear conversion to the clip.

You can apply a conversion directly to a clip. When stored as linear data, you can connect the clip to any node in the schematic. You have the option of

changing the clip's bit depth, including returning the clip to a bit depth of 16 bits, allowing you to work with the clip's high-dynamic range properties.

See [Converting OpenEXR Images](#) on page 770 and [LUT Editor Node](#) on page 1357.

To apply a conversion directly to a clip:

- 1 Select an OpenEXR-formatted clip.
- 2 Do one of the following:
 - Click Basic and enable the RGB LUT button to use current EXR Display settings.
 - Click RGB LUT to access the clip's LUT Editor, and enable the Active button to use current EXR Display settings.
 - Disable either of these buttons to work with the full range of data in the clip.
- 3 To convert the output, select the bit depth in the Destination menu.

To apply a conversion to a clip using the LUT Editor node:

- 1 Import or load an OpenEXR-formatted clip stored at 16 bits.
- 2 Drag a LUT Editor node to the Batch schematic and connect it to a clip.
- 3 Select the node.
The LUT Editor appears.
- 4 From the Conversion LUT Type box, select EXR Display.
- 5 To convert the output, select the bit depth in the Destination menu.

Modifying Clips in Batch

You can modify a clip at any stage while building your effect without having to exit Batch. Changes made to the clip are updated and reflected automatically throughout the process tree. Once modified, the clip is ready to be used in the Batch pipeline. To modify clips, you have access to the Basic, LUT Editor, Timeline, Audio, and Resize controls from Batch, as well as access to a clip's history.

To modify a clip:

- 1 In the Batch schematic, select the clip you want to change.
- 2 Click one of the Clip Edit buttons.



Click:	To:
Basic	Modify timeline and timewarp options, control clip locking and slipping, and define how missing media is displayed and processed. See Defining Missing Media Output on page 1290.
Resize	Change the size of a clip, as well as its aspect ratio. See Resize Settings on page 681.
RGB LUT	Open the LUT Editor for the selected clip. From this editor, you can also change a clip to output as 8 or 12 bits. See Accessing the LUT Editor on page 745.
Timeline	Display the timeline of the clip selected in the schematic. Perform editing operations, such as cuts, slides, slips, timewarps, and dissolves on the selected clip. See Editing to the Batch Timeline on page 1015 and Navigating the Timeline on page 969.
Audio	Edit the audio individually from its assigned video. See Audio on page 1195.

- 3 Change your clips, as required.
Modified clips are updated in Batch immediately.
- 4 Activate or disable LUTs and resize functions for a clip using the RGB LUT and Resize buttons.
This allows you to enable or disable a clip change quickly without reentering the Resize or RGB LUT menu.

Modifying Clips with Clip History

Certain clips that you previously modified have clip history, which is a system for keeping track of changes made to clips. You can load these clips into Batch, which shows you, using a process tree, how the clip was modified. When you expand a clip with clip history into a Batch process tree, you can modify the clips and nodes as you would for any Batch schematic, and then process a new clip. See [Clip History](#) on page 807.

Defining Missing Media Output

You can define how missing media in a clip is processed by a node. You may want to apply effects to a clip that includes one or more gaps, or you may want to manipulate a node with multiple inputs that is not yet connected to a required input. You can view the results of the selected options in the image window.

To define how a clip's missing media is interpreted:

- 1 In the Batch schematic, select a clip.
- 2 Select Basic.
The Basic menu appears.
- 3 Select from the following No Media options to determine how to interpret missing information before, during and after a clip.

Head Media	Repeat First
Gap Media	Use Black
Tail Media	Repeat Last

Select:	To:
Repeat First	Substitute each frame of missing media at the beginning of the clip with the first frame of media. Applies to the Head Media menu only.
No Media	Not substitute missing media. Display an error message that there is no media to be processed by the node.
Use Black	Substitute each frame of missing media with a black frame.
Repeat Last	Substitute each frame of missing media at the end of the clip with the last frame of media. Applies to the Tail Media menu only.

If an input tab cannot process missing media, most nodes that process clips set to No Media will display a warning. The BFX Output, Output, and Export nodes automatically process gaps in clips set to No Media as black frames. See [Managing Missing Media Output](#) on page 1332.

Adding Nodes to the Schematic

You can add as many nodes as you need to create complex effects. Since Batch is designed to match your workflow, you add nodes in a similar order as you would by going from module to module.

To add a node to the schematic:

- 1 From the View box, select BatchSchm or swipe the bar at the left to display the node bins.

TIP Press **Ctrl+Tab** to display the node bins quickly.

- 2 From one of the four node bins, select a node.

TIP Drag in each node bin to scroll the nodes.

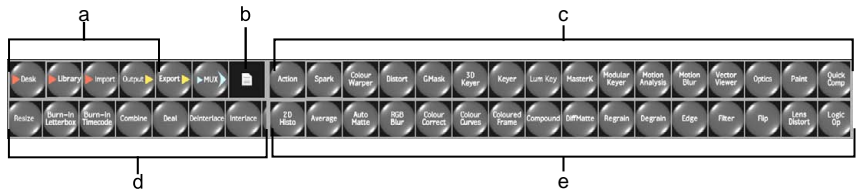

(a) Input and Output nodes (b) Note icon (c) Formatting nodes (d) Effects nodes
(e) Processing nodes

- 3 Do one of the following:
 - Drag the node from the node bin and place it anywhere in the schematic.
 - Double-click the node in the bin to display a node to the right of the last selected node in the schematic.

To use the node in the process tree, you must connect it to other nodes or clips. See [Connecting Clips and Nodes](#) on page 1292.

- In the schematic, click the node to access the module for the selected node. For example, when you select an Action node in the schematic and you want to create a composite, click the Action node to access the full Action module.

NOTE Some nodes require you to enter their module by clicking the Edit button. Once you have performed your edits, click Return to return to Batch with the latest unprocessed setup for the selected node.

Repeat this procedure for all the nodes you set up in your process tree. For a description of each Batch node, see [Batch: Node Reference](#) on page 1329.

Connecting Clips and Nodes

As you add nodes, you connect them to the process tree by linking the result from one node and using it as a source (front, matte, or back) for the next node in the process tree or by linking backward from the source of a node to the output of another (to reuse a node's output). The only exceptions are the BFX Output, Output, and Export nodes: you cannot link from their result.

To connect nodes, you use the coloured tabs on the node's left side; these tabs are called *source tabs*. The colours of the source tabs correspond with the cursor colours when selecting clips from the Flame reels. The yellow tab on the node's right side is called the *Result tab*. You use the Result tab of a node to connect its result to the front, back, or matte tab of another node.

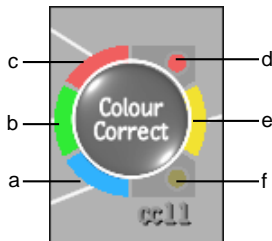

(a) Matte tab (b) Back tab (c) Front tab (d) Warning tab (e) Result tab (f) Cache tab

Node source tabs are described in the following table.

Tab	Colour	Description
Front	Red	Connects a front clip to a node.
Back	Green	Connects a back clip to a node.

Tab	Colour	Description
Matte	Blue	Connects a matte clip to a node.
Audio	Aqua	Connects a clip with audio to an Output node.
Result	Yellow	Connects the result of a node to other nodes.
Output Matte	Blue	Connects the output matte of a node to other nodes.
Cache	Grey and yellow circle	Enables, disables, or sets cache as read only for the selected node. See Caching Frames on page 1319.
Warning	Red circle	Warns you that clip input to this node is unconnected or missing media, or clips parented to this node do not share the same resolution or a compatible bit-depth. A message also appears in the message bar (press Alt+E and mouse over the node to redisplay the message.)

The available source tabs depend on the node. If the node accepts a front, back, and matte clip, all coloured source tabs are available. If the node only accepts a front clip, the red source tab is available and the other source tabs are grey. The Result tab is always available, except on the BFX Output, Output, and Export nodes. When a source tab or Result tab is not connected to a clip or to another node, the coloured tabs are dimmed.

There are several different ways of connecting clips or nodes together. You can connect them manually or automatically. You can also quickly connect several nodes and clips together using the tap-tap feature.

To connect a clip to a node:

- 1 Click the clip and drag the cursor to a source tab on a node. Alternatively, select Parent from the Edit Mode box and drag the cursor to a source tab.

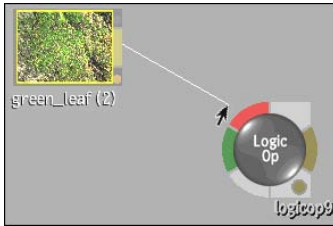

Dragging from a clip to the front tab of a Logic Op



(a) Edit Mode box

An arrowed line is drawn from the clip to the source tab. The colour of the line corresponds to the colour of the source tab to which the clip is connected.

For example, if you want a clip to be used as the front clip for the Colour Correct node, a red arrowed line is drawn in the schematic connecting the clip and the node.

To connect nodes manually:

- 1 Click the Result tab of a node whose result you want to use and drag the cursor to one of the source tabs of the next node in the process tree.

An arrowed line is drawn from the node to the source tab. For example, click the Result tab of the Colour Correct node and drag the cursor to the front tab of the Flip node to flip the result of the colour-corrected clip.

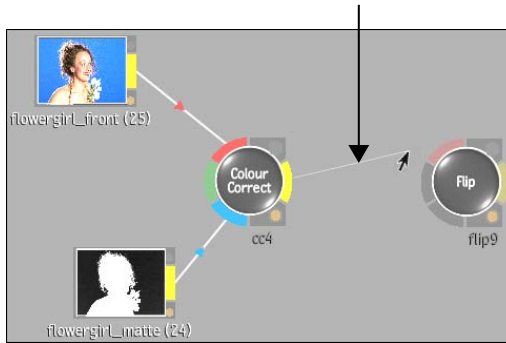

To connect nodes automatically:

- 1 Use the Autolink feature by pressing **Shift** and dragging a node to another node so their tabs touch. The nodes are connected.

NOTE Using Autolink to connect nodes will not connect an audio input to an Export or Output node.

Action: Press and hold **Shift** while dragging the **Negative** node to the **Keyer** node

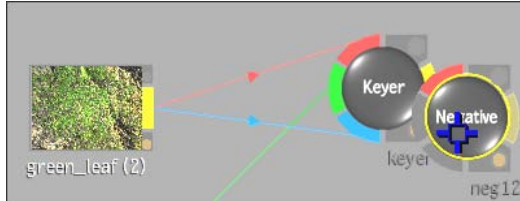

Result: The **Keyer** output is the front for the **Negative** node

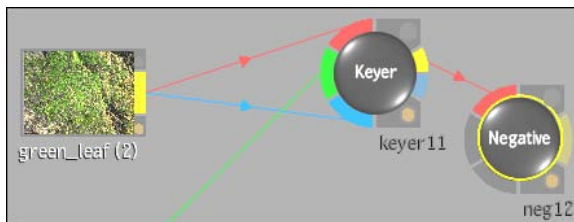

To create a node connection using tap-tap linking:

- 1 Click the socket of the first node or clip you want to connect.
- 2 Click the socket of the node you want to connect the first node to.
The nodes are connected.

NOTE If the first node you click is an Output node, you can add as many subsequent input socket connections as you like. To finish selecting, click anywhere in the schematic work area.

To simultaneously break a connection and add a new input:

- 1 Connect the new clip or node's Result tab to the source tab of a node that is already connected to a different source.
The source tab's original link is disconnected and replaced with a connection to the new Result tab.

To disconnect nodes or clips:

- 1 Drag the cursor across the connecting line between a clip and a node or between two nodes.
The arrowed line is cut and the source tab is dimmed.
- 2 You can cut multiple connections in a single stroke by clicking and dragging over several connecting lines in the schematic.

TIP To quickly disconnect a node, press **Ctrl+Alt** and click the node to disconnect.

Working with Multiple Connections

When connecting clips and results, you can have single or multiple connections. This means that you can connect a clip to many different nodes. You can also connect a node's Result tab to more than one node if you want to reuse a node's output elsewhere.

In the following example, the `flowergirl_front` clip is connected to the Front tab of a Colour Correct node and two Keyer nodes. The `silk_back` clip serves as the back for both Keyer nodes and the Action node. The result of the Colour Correct node is connected to two Action media nodes, one of which has a

Logic Op node result feeding into it. Finally, the entire process tree feeds into one final output.

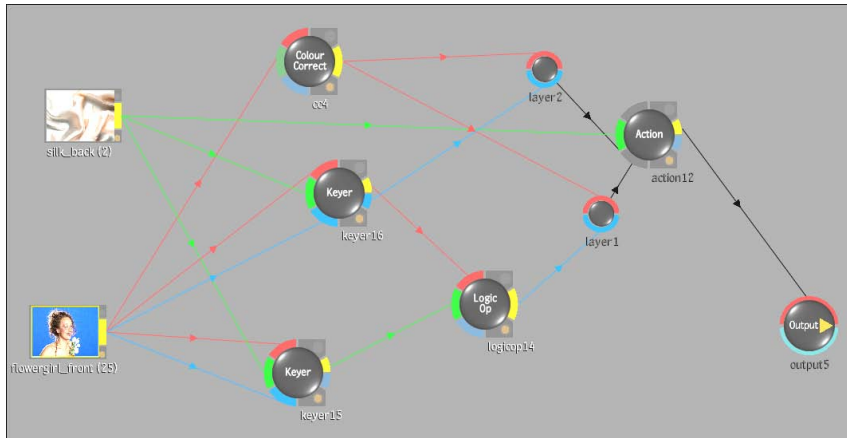

To add a connected clip:

- 1 Double-click a coloured source tab.
The Flame appears. The cursor is the same colour as the first unassigned tab.
- 2 Select a clip.
The arrow changes colour if the node has other unlinked source tabs.
- 3 Continue to select clips for unlinked tabs or click Exit Clip Select.
You are returned to Batch, where the selected clips are added to the process tree and connected to the node.
For example, the node on the left shows a Logic Op node before double-clicking a source tab. The process tree on the right shows the same

Logic Op node after double-clicking the red source tab and selecting a front clip and a back clip from the Flame.



Manipulating Nodes

As you build your process tree, you can reposition the nodes to keep track of the processing direction.

Once you position the nodes, you may want to give them more descriptive names, copy process trees, create groups, and delete unnecessary nodes. You must select a node, multiple nodes, a branch, or the entire process tree before moving, copying, grouping or deleting them. To carry out these tasks, you use the Process Tree controls.



(a) Selection Mode box (b) Set Context button (c) Edit Mode box (d) Name field (e) Au (Audio Context) button (f) Group button

The Process Tree controls are described as follows.

Name field Assigns a unique and descriptive name to nodes and clips.

Edit Mode box Sets the manipulation mode in the schematic.

Select:	To:
Move	Move nodes, branches, and process trees in the schematic. In this mode, you can also parent and cut connections gesturally in the schematic.
Parent	Connect and disconnect clips and nodes.
Delete	Delete clips and nodes in the schematic, one at a time.

Undo and Redo buttons Undoes or repeats the last action performed whether in the schematic or in a module. You set the number of undo levels in the Setup menu.

Bypass box Bypasses the node, instead passing the selected clip downstream. See [Bypassing Nodes](#) on page 1303.

Set Context button Uses the currently selected node as a context for viewing in a viewport. See [Viewing Nodes in Context](#) on page 1315.

Audio Context button Uses the currently selected audio clip as a context for another clip. See [Working with Audio Contexts](#) on page 1317.

Update button Forces an update of nodes that might not have processed the current frame.

Group button Creates a group with sets of nodes, branches, or process trees. See [Grouping Nodes](#) on page 1305.

Copy button Copies selected items in the schematic.

Delete button Deletes selected items in the schematic.

Selection Mode box Displays the node or set of nodes that you can select.

Reset button Resets a node, a branch of nodes, or an entire process tree according to what is selected in the Selection Mode box.

When you reset an Action, a Modular Keyer, or a Keyer node, the undo list is cleared. When an Action, a Modular Keyer, or a Keyer node is part of a branch in a process tree, you may accidentally clear the undo list when you reset these or other nodes. To prevent the accidental clearing of the undo list when you reset any of these nodes, the following warning appears and you are prompted to confirm:

Confirm reset? WARNING: This will clear the undo stack.

For example, when you click Reset to reset a Colour Warper node that is parenting a Keyer node, you must confirm.

Selecting Nodes

Fundamental to constructing a process tree is the ability to move, reorganize, and connect nodes in a logical manner. Before you can do any of this, however, you have to select a node.

To select nodes:

- 1 From the Edit Mode box, select Move.
- 2 From the Selection Mode box, select a mode.

Use:	To select:
Selected	One item in the schematic such as a clip or a node.
Branch	The nodes and clips contained in a branch. A branch is defined by a node and all the clips and nodes before it in the process tree.
Tree	An entire process tree.
All	The entire schematic, including all process trees.

- 3 In the schematic, make a selection.

To select:	Click:
An item	The node or image.
A branch	The first node in the branch you want to select. All nodes before it (upstream) in the tree are selected.
A process tree	Any node in the process tree with Tree selected.
All process trees	Any node in any process tree with All selected.

The selected nodes are highlighted. The clicked node is outlined in yellow and the other selected nodes are outlined in white.

Moving Nodes

You can move a node, a branch, a group, or an entire process tree. Typically, you move a node by dragging it in the schematic. You can move several nodes at a time.

To move nodes:

- 1 In the Edit Mode box, select Move.



In the schematic, the cursor changes to a blue crosshair.

- 2 In the Selection Mode box, select the nodes and clips you want to move.
- 3 Press **Alt** and click a node to move all selected nodes.

Copying Nodes

You can copy a node, a branch, or an entire process tree. You can also copy clips.

To copy a selection:

- 1 In the Edit Mode box, select Move.
- 2 In the Selection Mode box, select the nodes and clips you want to copy.
- 3 In the schematic, make your selection.
- 4 Click Copy to copy the selection.

A copy of the selection appears in the schematic.

Deleting Nodes

You can delete nodes or clips individually. You can also delete branches, process trees, as well as the entire schematic.

To delete a single node or clip:

- 1 In the Edit Mode box, select Delete.
In the schematic, the cursor changes to a red crosshair.

NOTE In Delete mode, you can only delete one item at a time.

- 2 Click the node or clip you want to delete.
The selected item is deleted.

To delete a branch:

- 1 In the Edit Mode box, select Move.
- 2 In the Selection Mode box, select Branch.
- 3 In the schematic, click the first node for the branch you want to delete.
All nodes and clips feeding into the clicked node are outlined in white and the leading node in the branch is outlined in yellow.
- 4 Click Delete.
The selected branch is removed from the schematic.

To delete a process tree or an entire schematic:

- 1 In the Edit Mode box, select Move.
- 2 In the Selection Mode box, select Tree or All depending on what you want to delete.
- 3 In the schematic, click a node in the process tree you want to delete or if you want to delete the entire schematic, click any node.
- 4 Click Delete.
The selected process tree or schematic is deleted.

To delete by dragging items out of the schematic:

- 1 In the Edit Mode box, select Move.
- 2 In the schematic, do one of the following:
 - Drag a node to the bottom of the screen. The cursor changes to a green recycling icon. The node is deleted.
 - Drag a node to the bottom of the screen while pressing **Alt**. The cursor changes to a green recycling icon. If Branch is selected from the Selection Mode box, the branch (the selected node and all incoming nodes) is deleted.
 - Drag a node to the bottom of the screen while pressing **Alt**. The cursor changes to a green recycling icon. If Tree is selected from the Selection Mode box, the entire process tree is deleted.
 - Drag a node to the bottom of the screen while pressing **Ctrl + Alt**. The cursor changes to a green recycling icon and the node is deleted. A link between the node before and after the deleted node is automatically created.

Bypassing Nodes

You can improve your workflow in Batch by deactivating certain nodes and rendering only the nodes that you want to process right away.

For any node, you can pass the Front, Back, Matte, or Key-in clip—depending on the type of node you select and its source tab inputs—as the input to the next node in a branch.

To bypass a node:

- 1 In the schematic, select the node that you want to bypass.

Typically, the bypass node will feed its result into a node that you want to render or work with more intensively, such as an Action node. For example, click a Keyer node that has Front, Back, and Key-in clips feeding into it.
- 2 In the Bypass box, select the clip you want to pass as the input to the next node.



The options that appear in the Bypass box depend on the inputs of the node you select in step 1. For example, the Keyer node has Front, Back, and Key-in clips as inputs to its source tabs, therefore they appear in the Bypass box.

The Keyer node operations are bypassed. In this case, only the back clip is passed.

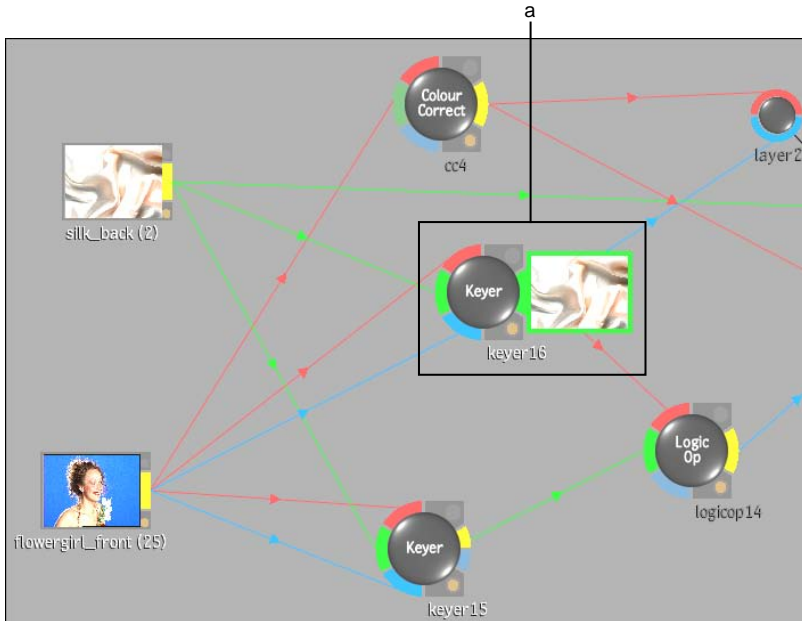

(a) Bypassed Keyer node

- 3 If you want to undo the bypass of a single node, select the bypassed node and in the Bypass box, select Result.
- 4 When you are ready to render the entire process tree, go to the Setup menu and click Unbypass to unbypass selected nodes.

NOTE Clicking Unbypass/Re-bypass affects whatever is selected in the selection box (All, Tree, Branch, or Selected).

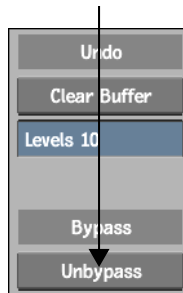

TIP You can use the - + Click key combination to bypass/unbypass a node.

Bypassing Action, Modular Keyer, or Keyer Nodes

The Action, Modular Keyer, and Keyer nodes each have two outputs: a result and a matte. If you bypass one of these nodes, the matte output will be the same as the result output (depending on the current selection in the Bypass box).

Grouping Nodes

You can group nodes to simplify cluttered schematics. When you group nodes, they collapse into one group node that you can use as a parent to, or child of, other clips and nodes. A group is represented by a single node that displays the group contents, inputs, and outputs.

You can create several groups and organize them in your schematic. You can then work on individual groups. For example, group a Keying and Colour Correction branch separately from an Action and filtering branch, and then work on each branch independently of the other. If you need to edit the nodes in a group, you can expand the group and make the necessary modifications.

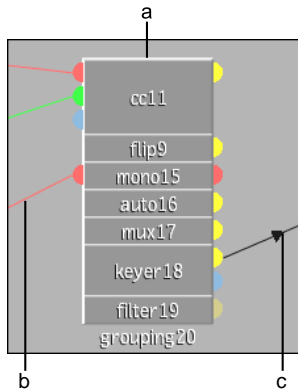

(a) Group node (b) Input connection (c) Output connection

A group is a dynamic node that you can customize using the Group List menu. The Group List menu lists all the nodes and connections contained in a group and lets you rename or hide them. In addition, you can define which input and output connection sockets are visible and available for connection in the schematic.

NOTE When you are working inside a group in Batch, the Burn button disappears.

To group nodes:

- 1 **Ctrl**-drag to select the nodes you want to group.
Selected nodes are outlined in white.
- 2 In the Process Tree controls, click Group.



The selected nodes collapse into a group node.

NOTE You can create a group inside a group.

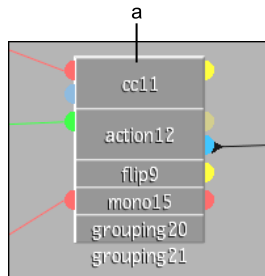

(a) The Group node lists the nodes contained in the group, as well as the non-hidden input tabs and output tabs

- 3 In the Name field, type a name for the group and press **Enter**.
The new group name is shown in the schematic.

You can select a node in the Group List menu to display the group at the selected node's stage. The View box must be set to Result, Front, or Back to use this display option.

Editing a Group

Use the grouping controls to adjust the contents of a group.

To edit a group:

- 1 Select the group you want to edit.
When you select a group node, the Process Tree controls change to show the List button, and the Group List menu displays the Ungroup, Edit buttons, and the Sort Order buttons.

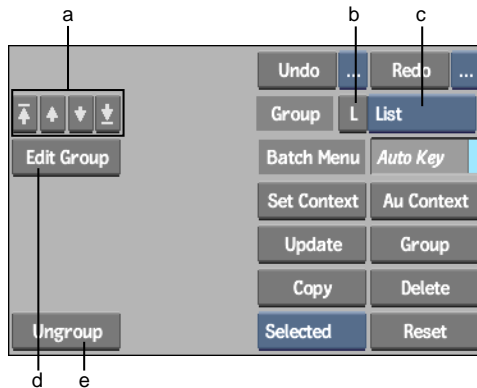

(a) Sort Order buttons (b) List button (c) Node List box (d) Edit Group button
(e) Ungroup button

- 2 Click Edit Group.

The nodes in the group appear in an isolated schematic.

TIP Instead of editing the group, you can access a single node's menu by selecting the node's name from the Node List box. Click the L (List) button to return to the Group List menu.

- 3 Modify the nodes as required.

NOTE Selecting All from the Selection Mode box while editing a group selects all nodes within the current group; any nodes outside the group in the current Batch pipeline remain unselected.

- 4 Click Exit Group to return to the main schematic.
- 5 Change the order of nodes in the group using the Sort Order buttons. The single arrow buttons move the selected node one position up or down, and the double-arrows move the selected node to the first or last position within a group.
- 6 Click Ungroup to expand the group of nodes to their pre-grouped positions in the schematic.

Defining Group Display Settings

You can customize the group node using the Group List menu.

To define a group's display settings:

- 1 Select a group to display the Group List menu.

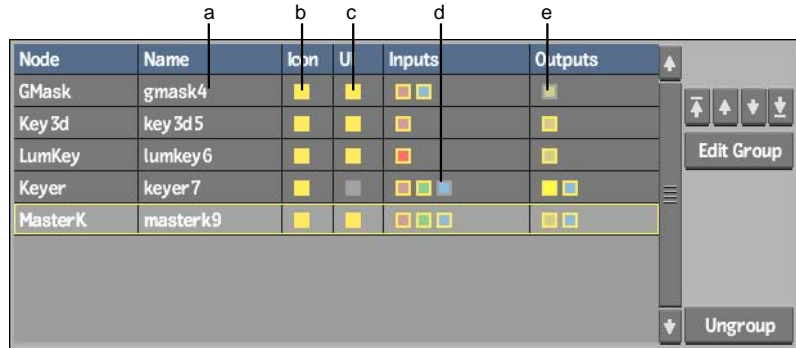

(a) Node name (b) Enabled icon visibility (c) Enabled UI visibility (d) Disabled input visibility (e) Disabled Output visibility

- 2 Change the group's interface by editing or toggling on any of the following node properties.

Click:	To:
Name	Change the node's name.
Icon	Toggle the node's visibility within the group.
UI	Toggle the node's availability in the Node List box.
Input	Hide or unhide the selected node's input sockets. Sockets are colour-coded with the same scheme as Batch nodes.
Output	Hide or unhide the selected node's output sockets. Sockets are colour-coded with the same scheme as Batch nodes.

Creating Custom Nodes

In addition to the standard node bins are two bins that can contain custom nodes. You can drag nodes, groups, branches, and whole Batch trees into a custom node bin to create a custom node. A custom node can consist of a single node, like a specific Colour Correct you need to use frequently, or a multitude of nodes that create an effect, such as a Keyer node parented to an Action node with layers connected to a GMask node. The newly created custom

node can then be pulled out of the node bin and into a schematic work area to be used anywhere in Batch as often as you like.

To create a custom node:

- 1 From the Batch schematic, select a clip, node, branch, tree, or group.
- 2 Drag and drop the selection to the appropriate custom node bin. The left custom node bin contains nodes for the current user. The right bin contains project nodes that are available to all users.

The selection is copied to the bin. The original selection remains in the schematic. If the selection is dropped outside of the bins, the selection is deleted.



User custom node bin

NOTE No two custom nodes can share the same name. Attempting to drop a node into a custom bin with a similarly named node is not possible.

To use a custom node:

- 1 Select a node from one of the bins. If necessary, scroll through the custom node bins.
- 2 Drag and drop the node into the schematic work area.

A node appears with the same configuration that was used to create the custom node.

You can use custom nodes as often as you like. Each time a custom node is dropped into the schematic work area, it is given a new name and/or number.

To manage the custom node bins:

- 1 Click one of the following to manage the nodes in the custom node bins. Both the user and project custom node bins have their own set of commands.

Click:	To:
Load	Load custom nodes from another project or user.

Click:	To:
Save	Save the current custom nodes so they can be loaded by another project or user.
Delete	Delete the selected custom node.
Clear Bin	Delete all custom nodes in the node bin. You must confirm the multiple deletion.
Arrow Buttons	Reposition custom nodes in the bin. The single arrow button advances one node at a time, and the double arrow button brings you to the first or last custom node.

Resolution Issues

A node's bit depth and resolution are not always compatible. It is not always possible to use clips of different resolution or bit depth. For example, it is not possible to have one custom Colour Corrector node with an 8-bit clip and another with a 12-bit clip. Garbage masks, on the other hand, work correctly with clips of different bit depth, but not of different resolutions.

Loading a Node's Setup

You can load the following nodes' setups from Batch:

- Action
- Auto Stabilize
- Colour Correct
- Colour Curves
- Colour Warper
- Degrain
- Difference Matte
- Distort
- Filter
- Gmask

- Lens Distort
- LUT Editor
- Motion Analysis
- Motion Blur
- Optics
- Paint
- Regrain
- Resize
- Text
- Vector Viewer

When you load a Batch setup, clips are searched for on the Flame reels and in the clip libraries. On the Flame, clips are searched for first by name, and then by clip ID. In clip libraries, clips are searched for by clip ID only—they are not searched for by name. If you delete a clip from the clip libraries that is used in a Batch setup file, you cannot replace it by giving another clip the same name. However, if you delete a clip on the Flame, you can replace it with another clip on the Flame that has the same resolution and name.

When you load a Batch setup using Append, a node with the same name as the one in the current Batch setup is renamed by adding zeroes to the name until a unique name is found. For example, if node1 and node01 exist in the current Batch setup, the appended node1 is renamed node001.

To load a node setup in Batch:

- 1 Select a node in the Batch schematic.
- 2 Click Node Setup to display the selected node's Setup menu.

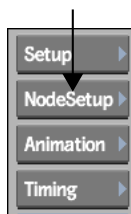

- 3 Click Load Node.

The file browser appears.

- 4 Navigate to and select a setup file. Once selected, the setup is loaded and you are returned to the Batch schematic.

Undoing and Redoing Operations

Use the Undo and Redo buttons to undo or redo operations performed in both the Batch schematic and individual modules.

You can only undo operations that affect the final result. For example, a slider edit, or node parenting can be undone, but not a view change or schematic pan.

Previewing Results

While creating your process tree, you can preview results at any time. If you do not like the result of one operation, you can modify or delete it without affecting the other operations in the sequence. You can preview your results in Batch by:

- Using proxies in the schematic
- Clicking one of the viewing buttons to view results at the current level in the image window
- Clicking the Level-up context button to view results one level higher than the current Batch FX level. See [Viewing Batch FX in Context](#) on page 1397.
- Clicking the Main Level context button to view results as they will appear at the top Batch level. See [Viewing Batch FX in Context](#) on page 1397.
- Setting up to two context nodes in Schematic view and viewing the results in context in the image window. See [Viewing Nodes in Context](#) on page 1315.

To preview results using proxies:

- 1 Click Setup.
- 2 In the Setup menu, enable Auto Update.
- 3 In the schematic, select the node whose result you want to preview.

- 4 Double-click the Result tab. Alternatively, press **T** as you click the Result tab.

The result proxy appears and shows the result up to and including the selected node.

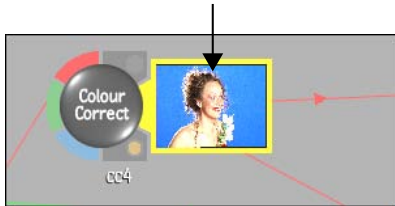

- 5 To close the proxy, double-click the Result tab again, or press **T** as you click the Result tab.

To preview results in the image window:

- 1 Select the node whose results you want to preview.

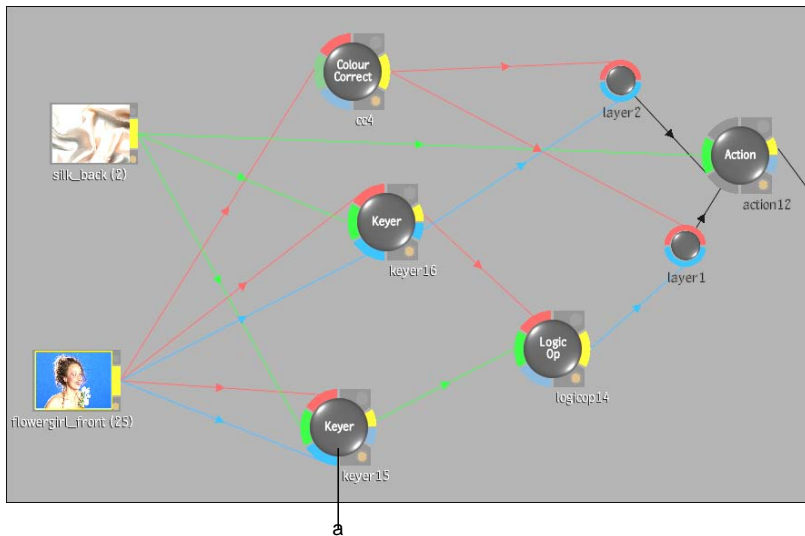

(a) For example, click the Keyer node

- 2 In the Batch menu, select Result from the View box.

The intermediate nodes are processed up to and including the selected node, and the result of the selected node is displayed in the image window.



Viewing Nodes in Context

You can view a node in context with another node to compare intermediate results throughout the process tree. By working with context points, you can modify nodes in the process tree and immediately view the impact those changes have on the nodes further along in the process tree.

You can set two context points in a process tree. The Process Tree menu includes the Set Context button for setting the context of a node operation.



(a) Set Context button

The following example has a process tree that includes a Colour Correct node that feeds into an Action node. Two Keyer nodes also feed into the same Action node. You can set the context on the Action node and continue modifying the Colour Correct node, while viewing the result of the Colour Correct node, the Keyer node, or the Action node.

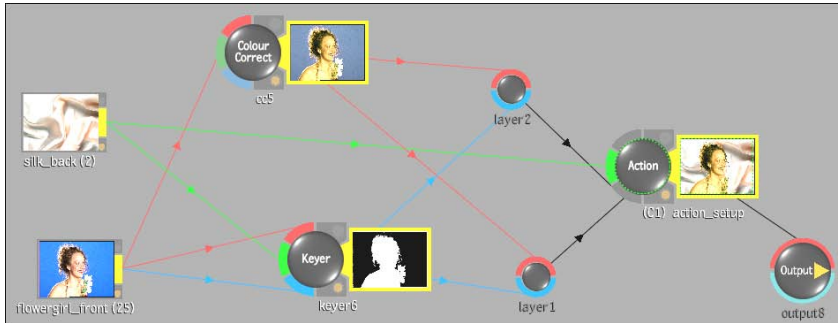

To view nodes in context:

- 1 In the schematic, select the node you want as the context. Using the preceding example, select the Action node.
- 2 In the Process Tree menu, click Set Context.

NOTE You can also set the context node by holding the = key and clicking the node you want to use. This method retains the current node selection.

(C1) appears next to the Action node name in the schematic.



- 3 In the schematic, select the node you want to edit. Using the preceding example, select the Colour Correct node and modify the setup.
- 4 View your colour correction changes in the context of Action by using preview proxies.
 - Selecting Context 1 from the Reference box
 - Clicking Result and selecting Context 1 or pressing F4

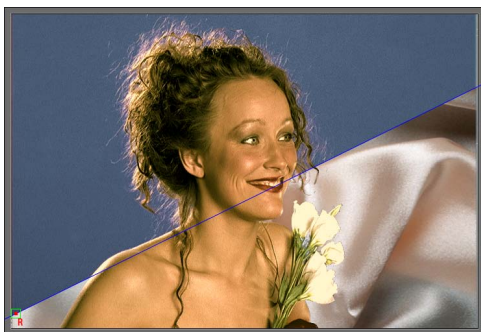

In this way, you are colour correcting “in context” of the intermediate result. Furthermore, as you move to different frames in the module, Context 1 also displays the result at the same frame. For instance, if you are at frame 15 in the Colour Corrector, Context 1 (Action) is also at frame 15. (Exceptions to this occur when using time-based nodes such as Motion Blur, Remove Pulldown, Add Pulldown, Interlace, and Deinterlace.)

- 5 If you want to set a second context, select another node in the schematic—such as the Keyer node—and click Set Context.
(C2) appears next to the Keyer node name.
- 6 Repeat steps 3 and 4.

Working with Audio Contexts

While working on one clip or branch of the process tree, you can listen to the audio of another clip. Audio contexts work in much the same way as video contexts. You can set up to two audio contexts in Batch.

To set an audio context:

- 1 In the Batch schematic, select a clip that contains audio.
- 2 Click Au Context to set the clip's audio as Audio Context #1 (or press **F10**).



Clips with an audio context are labelled A1 or A2 and are outlined by pink dots.

NOTE Selecting another clip and clicking Au Context again will set the second audio context. Repeating this with another clip will remove the context from the first audio clip and make the new selection Audio Context #2, since only two audio contexts can be set at a time.

To hear an audio context:

- 1 Click Setup.
- 2 In the Audio Monitoring box, select an audio context to listen to.

Select:	To play:
Current	The audio of the currently selected clip.
Context 1	The audio of the clip set to Audio Context 1.
Context 2	The audio of the clip set to Audio Context 2.
Source	The audio of the Source clip.
Record	The audio of the Record clip.
Main Level	The audio of the clip selected at the main level of Batch.
No Audio	No audio.

TIP Cycle through the Context options using **F12**.

NOTE Playback of audio is only available when playing a clip. However, you can scrub audio anytime in Batch.

Caching Frames

You can avoid reprocessing the same nodes and clips as you navigate in the timebar by specifying which nodes and clips should be cached. Cached frames are stored on the system framestore, increasing system performance and efficiency. Stored cache clips are contained in a `_Cache_` library and correspond to the clip IDs in the setups. These cache library files are named according to setup and project name.

Node and clip caching is enabled in the Cache menu. The Cache menu also displays the number of rendered frames in the cache for the selected nodes or clips, and the remaining space on the framestore.

Any clip node and Import node can be cached as long as it is edited, resized, or has had a LUT conversion applied. Batch setup files include the location of any cached frames, which are stored with the clip ID until removed. The history associated with a clip can also be cached, but not if the clip was rendered in Proxy mode.

Each node and clip has a cache tab on the lower-right corner.

The following steps are not required to actually cache frames. Typically, you use intelligent caching, which automatically caches frames as you move through the timebar. Caching occurs as the frame is displayed and the node operation is applied. A cached node automatically saves frames as you display—or visit—them and then reloads them each time you visit the frame again. Your workflow speed is increased.



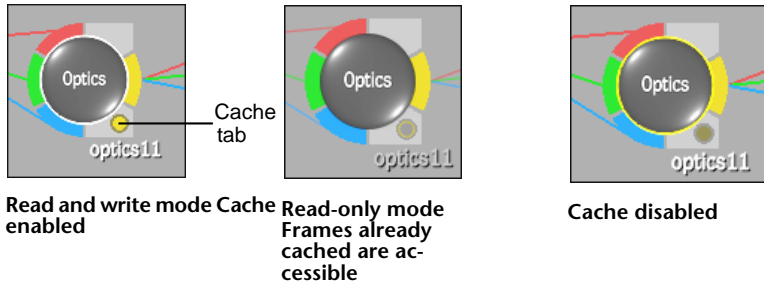

Click the cache tab to activate any of the following modes.

Mode	Colour	Description
Disabled	Grey	Disables the cache. You can also Alt -click to disable and remove cached frames for the selected node.
Read and write	Yellow	Saves and loads data to and from the cache.
Read-only	Amber	Is shown with a yellow outline. No data can be saved to the cache, but rendered frames remain stored. Use this mode to prevent the framestore from getting full.

Changing or cutting an input or any node further along the process tree that has cached frames clears the cache buffer. The Cache menu shows how many frames are cached for the selected node and the number of frames available on the framestore. This allows you to clear the cache of the selected node or all cached frames.

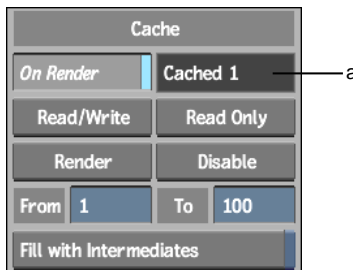

(a) Cached frame counter

To cache frames:

- 1 Click Setup.

- 2 Specify the frames you want to render and store in cache using the From and To fields.
- 3 Click Render Cache.
The cached frames are stored in the framestore and added to the cached frame counter.

To turn off the cache and remove cached frames, **Alt**-click the cache indicator for the selected node.

Rendering Caches During Processing

You can render node caches while processing.

To render node caches while processing:

- 1 Enable the cache for any nodes or clips whose frames you want to cache.
- 2 Click Setup.
- 3 Enable On Render.

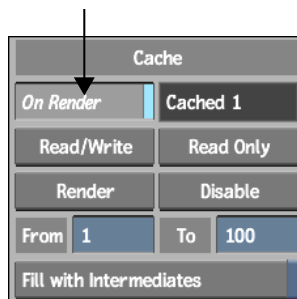

- 4 When you are satisfied with current settings in your process tree, click Process.
The clip is processed, and all node caches are rendered. While rendering, the message bar displays the number of frames in the node and the time remaining until the render is complete.

Sampling LUTs

When you use the colour patches in the LUT Editor menu in Batch to sample image channel values, sample the image before you resize it. When you try

to sample resized images, you sample the original front image, not the resized image. See [Comparing Colour Values Using Colour Patches](#) on page 765.

Using the Scan Format as a Rendering Parameter

When using the Burn-in Timecode, GMask, and Text nodes, you can use the import scan format of a clip as the rendering format. To do this, choose As Front from the Scan Format box.

For GMask:

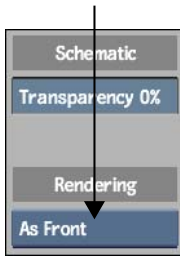

For Burn-in Timecode:

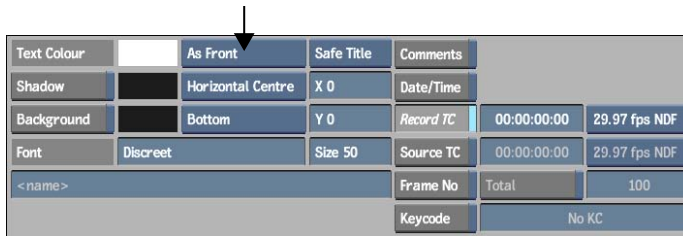

Outputting and Exporting Batch Results

When you are ready to generate the final clip or an intermediate result, click the Process button. All process trees in the schematic are processed, and one clip is written to the destination specified by each Output node or Export node. A Queue Manager lets you define several output or export processes and assigns instructions to each. The final output clips bear the name you specify in the Node Name field in the Queue Manager.

Once the nodes are in the Queue Manager, consider each output or export process as a job that has various instructions for how the final output is rendered. Each job can be active or inactive, has a unique name, specific start and end frames, and a specific destination. You can execute jobs immediately

or at a later time using a Batch script, as well as set job priorities. The jobs that appear in the Queue Manager are saved in the Batch setup file.

See [Output Node](#) on page 1365 or [Export Node](#) on page 1347.

Using the Queue Manager

Manage several output and export processes at a time using the Queue Manager. You can set priorities for particular output and export processes, specify the destination for processed output, attach a script, as well as determine the frames at which to start and end an export or output process. Furthermore, you can attach a script that contains elaborate instructions such as converting processed images to a movie file (.mpg) and sending notification messages about the status of various Batch processes.

In Batch, the Queue Manager is accessed through the Queue menu. To use the Queue Manager, you must add at least one Export or Output node to the Batch schematic. Output and export processes at the main Batch level are displayed in white. Processes at the Batch FX level are displayed in blue.

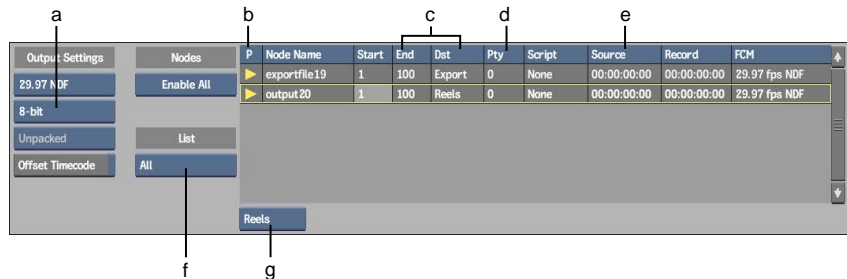

(a) Bit Depth box (b) Process indicator (c) Start and End frame (d) Destination (e) Batch script (f) Process Options box (g) Output box

To access the Queue Manager:

- 1 In the schematic, click an Output node or an Export node.
- 2 In the Batch menu, click a node to display its menu. If necessary, swipe the bar at the left or right side of the menu.

The Queue Manager appears with the corresponding Output node or Export node controls. Once an Output or Export node appears in the Queue Manager, it is considered a job.

3 In the Process Options box, select one of the following options.

Select:	To process:
All	All Output or Export nodes.
Current	The visible Output or Export nodes in the current view.
Current + Group	All Output or Export nodes in the current view (even if they are nested inside a group).

The Queue Manager updates to show the pending jobs.

4 In the Node Name field, provide a name for the job.

Each row in the Queue Manager contains details about a Batch job. They are described as follows.

FPS box (Output node only) Sets the Frame Code Mode to be applied to your output. The mode is displayed in the FCM column.

Export box (Export node only) Displays an export format.

Bit Depth box Defines a bit depth for the file to be Output/Exported.

Compress button (Export node only) Enables file compression.

Offset Timecode (Output node only) Enables any timecode offsets you made in the Queue Manager. For example, if you specify a timecode for output of 00:00:00:00 and render from frame 1, the first frame will have TC 00:00:00:00. If you then specify a timecode for output of 00:00:00:00 and render from frame 10 without enabling Offset Timecode, the first frame for the render will be TC 00:00:00:00. However, if you specify a timecode of 00:00:00:00 and render from frame 10 and *enable* Offset Timecode, the first frame of the render will have TC 00:00:00:09.

NOTE Timecode shown in the Rec TC and Src TC is offset based on the first frame.

Enable All/Disable All button Activates and deactivates all processing on all Output and Export nodes in the processing tree.

Process indicator Activates the Output or Export node for processing.

The arrow in the P column is bright yellow when a job is active. When you click Process, all active jobs are processed.

Node name Provides a descriptive name for the processed clip.

Start and End frames Specify the range of frames you want rendered for the job and in the processed result.

This means that one Output node could be set to process the first 30 frames of a 60-frame clip, and another Output node could process the remaining 30 frames.

The Start and End fields override the total number of frames in the timebar. For example, if the timebar shows a 60-frame clip and an Output node is set to start at frame 20 and end at frame 100, then 80 frames are processed.

Destination Specifies the destination for the output or exported result. The destination is either the Flame reel or clip library.

Priority Specifies the priority of jobs to process.

Script Attaches a script file whose content is executed when the Output or Export node is finished rendering. Scripts must have the file extension *.bscript*.

Click this field to load an existing script from the file browser.

Source Lets you generate your output with a source timecode. To edit the timecode, double-click the field and enter a new value.

Record Lets you generate your output with a record timecode. To edit the timecode, double-click the field and enter a new value.

FCM Displays the Frame Code Mode. Change this value using the FPS box.

Output box (Output node only) Defines whether the output will be written to the Reel on the Desktop, or in a Library. If Library is selected, you are prompted to select from your existing libraries.

Adding Clip Parameters to the Output

You can add a clip's name, duration, source, and record timecodes, in and out points, and FCM to the Queue Manager.

To add clip parameters to the Queue Manager:

- 1 Select an Output node.
- 2 Press **T** and click a clip.
- 3 The clip's SRC and REC TC parameters, as well as its duration and in and out points, are added to the Queue Manager of the selected Output node.

Importing and Exporting LUTs

When you save the Import or Export node in Batch, two LUT files are saved—one for the RGB channels and one for the matte. The files are named as follows:

- `<node>.lut_node`
- `<node>_alpha.lut_node`

Using Scripts

Batch scripts are ASCII files that contain instructions related to a Batch job. They must have the file extension *.bscript* for Batch to recognize them. A Batch script is executed after the Output or Export node to which the script is associated has finished rendering.

NOTE Use the *imgview* and *movie* scripts with the Export node, and use the *listVariables* script with the Export or Output nodes.

You should consult with your system administrator when creating scripts. Scripts are created using either C shell, Korn shell, or Perl. Also, Batch scripts must have the proper file access, directory access, and execution permissions for the files, directories, and applications in the script.

When the script is executed, Flame continues with its own processes and does not wait for the script to terminate. Flame imposes no restrictions with executing scripts; however, make sure that no one else is using the system when a script is executed and that the script is approved by your system administrator.

Script variables that you can set are defined in the following table.

Variable	Description
BATCH_NODE_NAME	Corresponds to the name of the Output node or the Export node. This is the same name that you provide in the Queue Manager Node Name field.
BATCH_FIRST_FRAME	Corresponds to the first frame displayed in the Queue Manager for the selected node name.
BATCH_LAST_FRAME	Corresponds to the last frame displayed in the Queue Manager for the selected node name.

Variable	Description
BATCH_ASPECT_RATIO	Corresponds to the framestore aspect ratio.
BATCH_FRAME_RATE	Applies only to scripts associated with Export nodes. This is the framerate of the final clip result.
BATCH_FRAME_WIDTH	Applies only to scripts associated with Export nodes. Corresponds to the width of the final clip result.
BATCH_FRAME_HEIGHT	Applies only to scripts associated with Export nodes. Corresponds to the height of the final clip result.
BATCH_OUTPUT_DST	Applies only to scripts associated with Output nodes. Indicates the destination of the final clip result as either the Flame reel or a clip library.
BATCH_BIT_DEPTH	Applies only to scripts associated with Export nodes. Specify the bit depth of the final clip result.
BATCH_CROP_WIDTH	Applies only to scripts associated with Export nodes. Specify the crop width of the final clip result.
BATCH_CROP_HEIGHT	Applies only to scripts associated with Export nodes. Specify the crop height of the final clip result.
BATCH_FILE_FORMAT	Applies only to scripts associated with Export nodes. Indicates the numbering format of a sequence of exported images in the final clip result. This numbering sequence ensures that the order of frames in the clip is intact when you import the clip.
BATCH_FILE_EXT	Applies only to scripts associated with Export nodes. Specifies the format to which the final clip result is being exported: Alias (<i>.als</i>), Cineon, Dpx (Spirit), Jpeg (<i>.jpg</i>), Pict (<i>.pict</i>), Pixar (<i>.picio</i>), Sgi (<i>.sgi</i>), SoftImage (<i>.pic</i>), Targa (<i>.tga</i>), Tdi/Maya (<i>.iff</i>), Tiff (<i>.tif</i>), or Wavefront (<i>.rla</i>).
BATCH_FILE_DIR	Applies only to scripts associated with Export nodes. Indicates the file location of the final clip result.

Executing Batch from the Command Prompt

You can execute Batch directly from a command shell so that you can render complex process trees while the machine is not in use, such as overnight. The following command starts Flame for a specified user, and renders a specified Batch setup:

```
flame -b batchsetup -U user - J project
```

NOTE The specified user and project name must be valid.

Topics in this chapter:

- [About Batch Nodes](#) on page 1330
- [2D Histogram Node](#) on page 1332
- [3D Keyer Node](#) on page 1332
- [Action Node](#) on page 1333
- [Add Pulldown and Remove Pulldown Nodes](#) on page 1335
- [Auto Matte Node](#) on page 1336
- [Auto Stabilize Node](#) on page 1336
- [Average Node](#) on page 1339
- [BFX Output Node](#) on page 1339
- [Burn-In Letterbox Node](#) on page 1341
- [Burn-in Timecode Node](#) on page 1342
- [Colour Correct Node](#) on page 1342
- [Colour Curves Node](#) on page 1342
- [Coloured Frame Node](#) on page 1343
- [Colour Warper Node](#) on page 1344
- [Combine Node](#) on page 1344
- [Compound Node](#) on page 1345
- [Deal Node](#) on page 1345
- [Degrain and Regrain Nodes](#) on page 1345
- [DeInterlace and Interlace Nodes](#) on page 1346
- [Desk Node](#) on page 1346
- [Difference Matte Node](#) on page 1346
- [Distort Node](#) on page 1347

- [Edge Node](#) on page 1347
- [Export Node](#) on page 1347
- [Field Merge Node](#) on page 1348
- [Filter Node](#) on page 1348
- [Flip Node](#) on page 1349
- [Glow Node](#) on page 1349
- [GMask Node](#) on page 1350
- [Import Node](#) on page 1350
- [Keyer Node](#) on page 1351
- [Lens Distort Node](#) on page 1352
- [Library Node](#) on page 1356
- [Logic Op Node](#) on page 1356
- [Luminance Key Node](#) on page 1357
- [LUT Editor Node](#) on page 1357
- [Master Keyer Node](#) on page 1358
- [Matte Curves Node](#) on page 1359
- [Modular Keyer Node](#) on page 1359
- [Monochrome Node](#) on page 1360
- [Motion Analysis Node](#) on page 1360
- [Motion Blur Node](#) on page 1362
- [MUX Node](#) on page 1364
- [Negative Node](#) on page 1364
- [Notes Node](#) on page 1365
- [Optics Node](#) on page 1365
- [Output Node](#) on page 1365
- [Paint Node](#) on page 1368
- [Posterise Node](#) on page 1369
- [Quick Composite Node](#) on page 1369
- [Resize Node](#) on page 1369
- [RGB Blur Node](#) on page 1370
- [Spark Node](#) on page 1372
- [Text Node](#) on page 1373
- [Vector Viewer Node](#) on page 1373

About Batch Nodes

Each node in Batch corresponds with one of the Flame commonly used modules or a command. The Flame functions that you use in Batch are contained in four sets of node bins.

To display node bins, click the left swipe bar.

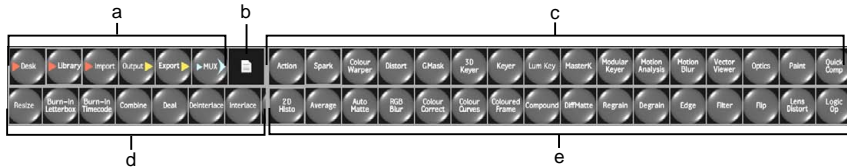

(a) Input and Output nodes (b) Notes node (c) Effects nodes (d) Format nodes
(e) Processing nodes

- Input and Output nodes—for loading and importing source clips, as well as processing and exporting rendered clips.
- Processing nodes—for processing clips using nodes whose functions are found in the Processing menu.
- Format nodes—for formatting frames in a clip using nodes whose functions are found in the Format menu.
- Effects nodes—for creating special effects using nodes whose functions are found in the Effects menu.

TIP If you do not see the node you are looking for, scroll the nodes in the bar with a click and drag.

Accessing a Node's Menu

Each node's menu can be displayed in Batch, allowing you to easily access its controls.

To access a node's menu:

- 1 Disable the Setup menu button.
- 2 Select the module node from the Batch schematic.
The module's respective menu appears.
- 3 Tap the left swipe bar to return to the Batch schematic.

Managing Missing Media Output

A node processes missing media in a clip based on the clip's settings (see [Defining Missing Media Output](#) on page 1290). Most nodes that receive missing input from clips set to No Media will not process affected frames and display a warning. However, the BFX Output, Output, and Export nodes automatically processes gaps in No Media clips as black frames.

There are nodes that process a No Media clip based on the type of input tab that is receiving the information. The Action, Paint, and Text nodes receive No Media clip information based on its source, and the current input and clip settings of the node's other inputs.

Supporting Floating-point Images

Floating-point images in the OpenEXR file format can be added to a Batch processing tree. Some nodes can be connected immediately downstream of a clip, while others must first be attached to a LUT Editor node to convert it to a linear image. See [Viewing Clips in the LUT Editor in Batch](#) on page 750 and [LUT Editor Node](#) on page 1357.

2D Histogram Node

Use the 2D Histogram node to display the luminance distribution of the matte. This node can be placed anywhere in the Batch process tree.

See [Adjusting the Luminance of the Key](#) on page 1569.

3D Keyer Node

Use the 3D Keyer node to key out a given range of colours. The 3D Keyer provides a high level of control over the settings of the key. You can also view your animation data in the Universal Channel Editor.

You can access the 3D Keyer directly from Batch. When you click a 3D Keyer node, the controls appear at the bottom of the screen; you do not need to go into the Modular Keyer to access the 3D Keyer.

The 3D Keyer node accepts a front clip as input. You use it as the key-in clip, to create a matte for the front clip. See [3D Keyer](#) on page 1661.

Action Node

Action nodes provide in-context access to a fully functional Action module. Click the Action node in the schematic to access it.

This node supports floating-point (OpenEXR) input.

You can parent a back clip to the Action node in Batch. Although doing so is not necessary, a parented back clip node provides a good visual reference for identifying the Action composite in the process tree.

To parent a back clip to an Action node in Batch:

- 1 Swipe the left side of the screen to show the node bins.
- 2 From the Effects node bin, drag an Action node to the schematic.
- 3 Add the clip that you want to use as the back clip for the Action composite to the schematic. See [Adding Clips to the Schematic](#) on page 1285.
- 4 With Parent mode selected from the Edit Mode box, drag from the clip node to the Action node's green input tab.



When you add an Action node to a process tree, you can either add indirect media, which appear in the Batch schematic, or add direct media from the Action module. Direct media does not appear in the Batch schematic.

Indirect Action Media

You can add Media nodes to an Action node in Batch. Attached to the Action node, a Media node has the following properties:

- A Media node is permanently parented to the Action node (you cannot sever these process lines).
- Media nodes have red and blue input tabs for the front and matte clips, respectively.

- Media nodes support floating-point (OpenEXR) input.

NOTE If a Media node contains media that is missing a Flame clip, the Action node's name is highlighted in red.

To add media to an Action node in Batch:

- 1 Click the Action node.
The Action menu appears.

- 2 Click Media.
The Media menu appears.

- 3 Do one of the following:

- Hold **Ctrl** and click Add to add media.
- Select media that has a front and/or matte, and press **Ctrl+Add**.

The Media node and its clips (if any) are added to the Batch schematic.

NOTE Deleting a Media node's clips that have been added to the Batch schematic will make the clips unavailable in the Action module.

- 4 Parent the appropriate front and matte clips to the Media node:

- Parent the front clip to the red input tab.
- Parent the matte clip to the blue input tab.

Media nodes that you set up in Batch are represented in the Media List with brackets (“[]”) around the input clip names.

Advantages and Limitations

If you create indirect Action media in the Batch schematic, note the following advantage. You can create complex effects processes (for example, a glow or a spark) that you can pipe into a Media node. Setting up indirect media is a good way to work on pre-processes for clips that you want to input into media.

If you create indirect Action media, note the following disadvantage. You cannot change the input clips for media set up in Batch from the Media menu of Action. If you attempt to do so, a message appears indicating that the selected media is indirect media. To change the input clips of indirect media, either return to the Batch schematic and then parent new front and matte clips to the Media node, or delete the Media node.

Direct Action Media

Instead of adding Media nodes in the schematic, you may prefer to set up the media for your Action composite directly inside the Action node. See [Action: Media](#) on page 2133.

Although direct media is not represented in the Batch schematic, media and all settings pertaining to it are saved with the Batch setup.

NOTE You can create direct media in the Action module (from the Batch Action node) and then add them to the Batch schematic by selecting media and pressing **Ctrl +Add**.

Missing Media

If a clip set to No Media is attached to an Action node and is missing media, the node's output is based on the tab to which the clip is connected, and the status of the node's other inputs.

The following conditions will output transparent Action media if the clip is missing media:

- A front clip set to No media
- A back clip set to No Media
- A matte set to No Media, with a front clip that is also connected to the Action node

If all media in the scene are transparent and no other information is input into the Action node, the node output is set to No Media.

Add Pulldown and Remove Pulldown Nodes

The Add Pulldown and Remove Pulldown nodes each accept a front clip as input:

- The Remove Pulldown node removes field artifacts introduced in a 24-to-30 fps conversion process.
- The Add Pulldown node produces the appropriate field sequence for converting a clip from 24 to 30 fps.

When either the Add Pulldown or Remove Pulldown nodes render a transition, preceding and subsequent frames with no media are replaced by black frames, regardless of Media settings for the missing media.

The First Processed Frame field sets the value at which output is processed from the node. Unprocessed output does not display any media.

These nodes also support floating-point clip input.

See [2:3 Pulldown](#) on page 703.

Auto Matte Node

The Auto Matte node accepts a front clip as input, which it uses to generate a high-contrast matte. The Auto Matte node menu is similar to the Auto Matte command in the Processing menu.

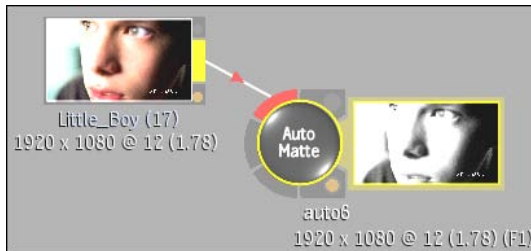

Image courtesy of Optimus

See [Using the Auto Matte Command](#) on page 1439.

Auto Stabilize Node

Use the Auto Stabilize node to rectify stabilization issues. For example, you remove camera jitter or lock an object's position over a sequence of frames to make it appear motionless. Attach a front clip to this node to analyse its movement. Matte input can be attached to this node to create an output matte, or to use black pixels on the matte to exclude areas from the stabilization algorithm. Use the parameters in the Auto Stabilize menu to refine the stabilization.

You can use the Revert feature to apply the inverse transformation to the input. For example, you can apply a stabilization analysis to a clip and connect the output to a Paint node to touch up a portion of it. You can copy the Auto Stabilize node and revert to the motion of the original input.

You can perform a two-dimensional analysis, which takes X and Y position, rotation, and scaling into account. You can select a three-dimensional analysis, which also analyses and compensates for perspective distortion. Select this option to stabilize a flat object moving in three-dimensional space, or if you are stabilizing a pan or tilt camera movement.

The X-axis, Y-axis, rotational, and scaling stabilization curves are calculated during analysis. If a perspective analysis is performed, perspective curves are also calculated. The data from all or a selection of these curves can be applied to the final stabilization of the result clip and output matte.



(a) Analyze button (b) Stabilization Method box (c) Region of Interest button (d) Stabilization Parameter buttons

Analyze button Click to run the stabilization analysis.

Use Matte button Use the black areas of the matte input to exclude those areas from analysis on the front.

Stabilization Method box Provides options to perform a two-dimensional or perspective analysis.

Scene Flexibility field Determines the level of focus on rigid objects that move in the clip. If the analysis has no scene flexibility, the stabilization will focus on a single rigid object as it moves in the clip. If the value is set to 100%, all visible motion paths are analysed.

In and Out fields Displays the range of frames included in the analysis.

Region of Interest button Display a rectangle that can be resized to indicate the region to be analysed on the front clip.

Smoothness field Displays the level of smoothness of the stabilization curves generated by the analysis.

Amount field Displays the percentage of smoothness used in the final stabilization output.

Stabilization Parameter buttons Enable to include a parameter in the stabilization. Enable the Lock button to link the parameter value at the reference frame to all frames in the analysis.

Padding box Provides fill options to pad the empty portions of the frame with the last line of pixels, a repeated (rolled) image, a mirror image, or black pixels.

Set Reference button Makes the current frame the reference frame for the stabilization.

Revert button Enable to apply the inverted parameter values.

2D Transform Offset fields Displays the X and Y position, rotational and scaling offsets applied to the clip. The offset is applied independently of the analysis if the corresponding Stabilization Parameter button is disabled.

Perspective Offset fields Displays the perspective offsets applied to the clip. These fields are enabled after a three-dimensional analysis.

To analyse a clip:

- 1 Enable Use Matte if you want to use the matte to constrain region of analysis.
- 2 Select an option from the Stabilization Method box.
- 3 Enter a percentage in the Scene Flexibility field. The following range of values are recommended:

Select:	To:
0%-20%	Stabilize a pan, tilt, zoom, or the motion of a single rigid object that is visible during the entire analysis.
30%-70%	Stabilize objects that change their shape or depth, and exclude objects that are smaller or moving rapidly.
80%-100%	Stabilize all visible movements.

- 4 Enable Region of Interest (ROI) to display a rectangle that constrains the the region of analysis to the area inside the selected area. The rectangle can be resized and animated (use the colour pot to change its colour).
- 5 In the In and Out fields, enter the range of frames to analyse.
- 6 Click Analyse.

When the analysis is finished, the stabilization can be customized further using the additional settings in the Auto Stabilize menu.

You can change the centre of rotation and scaling for the image. By default, the centre of rotation and scaling is the centre of the image, represented by a crosshair.

To change the centre of rotation and scaling:

- 1 Display the Front view (F1).
The crosshair that represents the centre of rotation and scaling appears.
- 2 Hold down **C** and click the new centre point.

Average Node

The Average node makes it possible to simulate motion blur in Batch. An image averaging function is applied to the frames to create the motion blur. Attach a front clip to the Average node. See [Simulating the Motion Blur of a Moving Object](#) on page 1428.

The Average node processes frames based on data from preceding and subsequent sample frames. A frame set to No Media with missing media may be included in a sample.

Input	Result
Current frame set to No Media	Frame set to No Media
Frame with media after gaps set to No Media	Frame using current and next frames
Frame with media before gaps set to No Media	Frame using current and previous frames

BFX Output Node

Use the BFX Output node to output Batch FX you have applied to a segment or a contiguous selection of segments. You can apply Batch FX using the same nodes that are available in Batch.

The BFX Output node accepts a front and a matte input. The node outputs the front as the RGB result. The matte is output as the alpha result.

The icon displayed on the node is dependent on its context. If the BFX level was entered with the Pre option, the icon background is grey. If it was entered

with the Post option, the background is black. If matte input is attached to the node, the icon displays an A next to the original BFX symbol.

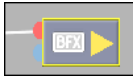

BFX Output node with front input

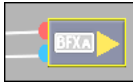

BFX Output node with front and matte input

From this node, you can edit LUT and resize settings for Batch FX. A segment with Batch FX displays the BFX icon, indicating it has been processed with a BFX Output node.

To access BFX Output settings:

- 1 Select a Batch clip in the schematic.
- 2 Click Timeline.
The Batch timeline appears.
- 3 If there is more than one segment in the clip, click the segment or place the frame positioner on the segment to select it.
- 4 Click Pre or Post to display the process tree for the selected segment.
- 5 In the schematic, select the BFX Output node.
- 6 Click one of the Batch FX Edit buttons.



Click:	To:
Basic	Display resolution and timecode settings.

Click:	To:
Resize	Change the output crop settings when the input has a different resolution or bit depth than the Batch FX output (the menu's Active button must be enabled). The destination resolution cannot be edited with this node. See Resize Settings on page 681.
RGB LUT	Change LUT Editor settings for the Batch FX output (the menu's Active button must be enabled). The destination bit depth cannot be edited with this node. See Accessing the LUT Editor on page 745.

For more information, see [Batch FX](#) on page 1375.

Burn-In Letterbox Node

Use the Burn-In Letterbox node to burn a letterbox into a clip.

To burn in letterbox:

- 1 Drag a Burn-In Letterbox node to the Batch schematic.
- 2 Attach the clip to the Burn-In Letterbox node.
- 3 Select an aspect ratio:
 - 1.33:1 (NTSC/PAL)
 - 1.37:1 (Academy)
 - 1.66:1 (European 35 mm)
 - 1.77:1 (HDTV)
 - 1.85:1 (American)
 - 2.35:1 (Cinemascope)
 - Custom (With Custom selected, enter a value for the aspect ratio in the Ratio field.)
- 4 If you want to offset the letterbox border, enter a value in the Offset field.
- 5 Click the Border Colour box to change the colour of the letterbox border.
- 6 Attach an Output node to your clip and then process the result.
The burn-in letterbox formatting is applied to the clip.

Burn-in Timecode Node

The Burn-in Timecode node has a Front input tab. If you are mixing clips that originate from formats that use different timecode, you may want to burn in information on a clip to keep a timecode reference clip.

You can also use this node to burn in keycode.

See [Burning-in Clip Information](#) on page 428.

Colour Correct Node

The Colour Correct node accepts a front, back, or matte clip as input. The results of a colour correction operation depend on which clip or combination of clips are linked to the Colour Correct source tabs.

For example, if you connect only a front clip, the colour correction is applied to the entire frame. If, however, you connect both a front and matte clip, the colour correction is only applied to the area defined by the matte.

You can load Colour Correct setups directly in Batch.

The Colour Correct node processes gaps in clips set to No Media based on the input tab receiving the information.

Input	Result
Front	No media
Back	Black frames
Matte	White frames

See [Colour Corrector](#) on page 1451.

Colour Curves Node

Use the Colour Curves node to access a clip's Colour menu, where you can remove colour spill from the front clip and perform a hue shift. You can save and load Colour Curves setups directly in Batch.

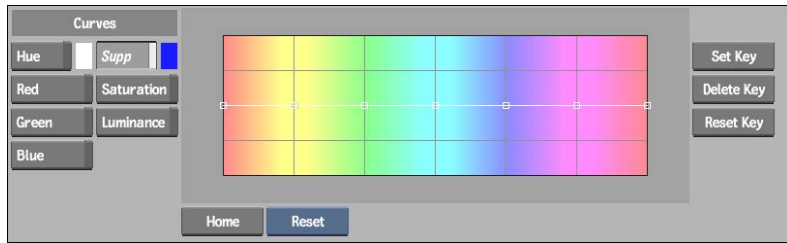

See [Suppressing Colours](#) on page 1472.

Coloured Frame Node

The Coloured Frame node generates a colour bar, noise, or colour clip that can be used as the clip for other nodes. You can specify the frame's resolution and bit depth. The Coloured Frame node menu is similar to the Coloured Frame command in the Processing menu.

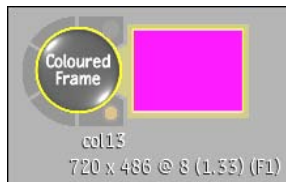

See [Creating Coloured Frames](#) on page 1442.

The Coloured Frame node includes eight colour pots for storing and selecting customized colours for creating frames.

To change the current colour of the Coloured Frame node:

- 1 Click the Current Colour pot.



- 2 Select a new colour using the colour picker.

- 3 Click the Current Colour pot again.

To customize a colour pot:

- 1 Click the Current Colour pot.
- 2 Select the colour you want using the colour picker.
- 3 Click a colour pot, holding the mouse button down until the colour changes.

All customized colour pots are saved with each Coloured Frame node. The information is also saved in the Batch setup file.

Colour Warper Node

The Colour Warper node accepts a front, back and matte clip as input. Use the Colour Warper node to access the Colour Warper module. In Batch, enable Result to display the image and the vectorscope in the image window. See [Colour Warper](#) on page 1483.

The Colour Warper node processes gaps in clips set to No Media based on the input tab receiving the information.

Input	Result
Front	No media
Back	White frames
Matte	Black frames

Combine Node

The Combine node combines individual channels of three different source clips. To generate a new clip, the Combine node merges the red, green, and blue channels from three clips into one.

See [Using Separate and Combine](#) on page 1446.

Compound Node

The Compound node makes it possible to combine the contents of several frames into a single frame. The value you enter in the Compound Over field determines exactly how the frames are combined. This is similar to Average, but the resulting clip is shorter, according to the original length/value in the Compound Over field. See [Creating Compound Images](#) on page 1431.

The First Processed Frame field sets the value at which output is processed from the node. Frames earlier than the entered value are included in the output but display the first processed frame.

Deal Node

The Deal node deals out the frames of a single clip evenly to any number of destination clips. The Clip field defines the number of times the clip is split; the Frame determines which of the dealt clips is output. See [Dealing and Interleaving Clips](#) on page 1448.

This node supports floating-point (OpenEXR) clip input.

The First Processed Frame field sets the value at which output is processed from the node. Unprocessed output does not display any media.

Degrain and Regrain Nodes

Use the Degrain and Regrain nodes to add and remove grain from the RGB channels of a selected colour in an image. The Degrain and Regrain nodes are the same as the Degrain and Regrain commands in the Processing menu.

The Degrain node accepts only a front clip as input. The Regrain node accepts front, back, and matte clips as input. See [Adding and Removing Film Grain](#) on page 773.

The Regrain node processes gaps in clips set to No Media based on the input tab receiving the information.

Input	Result
Front	No media
Back	Black frames
Matte	White frames

DeInterlace and Interlace Nodes

The DeInterlace node separates the odd and even scanlines of a clip. For each frame of the clip, the result clip contains one frame with odd scanlines (Field 1) and one frame with even scanlines (Field 2). The DeInterlace node accepts a front clip as input.

The Interlace node interlaces the odd and even scanlines of a clip. For each pair of frames in the input clip, the Field 1 scanlines of one frame are interlaced with the even scanlines of the second frame to produce a single frame in the generated clip. The node accepts a front clip as input.

The First Processed Frame field sets the value at which output is processed from the node. Unprocessed output does not display any media.

These nodes support floating-point (OpenEXR) clip input.

See [Deinterlacing and Interlacing Clips](#) on page 725.

Desk Node

Use the Desk node to access the Desktop, where you can load clips from the reels into Batch.

To load images from the Desktop reels:

- 1 In the Batch menu, swipe the bar at the left of the menu to display the node bins.
- 2 In the node bin, select the Desk node and drag it to the schematic. The desktop reels appear.
- 3 Select up to six clips.
- 4 If you select less than six clips, click Exit Clip Select or click an empty reel to return to Batch.

You return to Batch and the selected clips appear in the schematic.

Difference Matte Node

The Difference Matte node generates a matte clip from a source clip and a background. This allows you to remove an image from one context and add it to another. The matte is created using the Tolerance and Softness values that you specify. See [Generating a Difference Matte](#) on page 1437.

This node supports floating-point (OpenEXR) clip input.

Distort Node

The Distort node uses spline-based shapes to create warps and morphs of clips. See [Distort](#) on page 1821.

Edge Node

Use the Edge node to do one of the following:

- Create a greyscale image composed of the edges in an image. You can apply edge-detection to both colour and monochrome clips.
- Modify the edges of the key. You can apply the Erode, Shrink, and Blur filters to the edges of the matte.

The Batch Edge node is the same as the Modular Keyer Edge node. See [Edge Node](#) on page 1636.

NOTE When using the Edge node, values for blur width and height, and shrink and erode width will be scaled following the current resolution of the node. Switching an Edge node input from a PAL clip to an HD clip will update the width and height values automatically.

Export Node

Use the Export node to export the final processed result directly to disk without saving the clip to the framestore.

The Export node accepts a front clip and its matte source tab accepts an alpha channel, as long as the front tab has an input and an RGBA-supported format such as *.sgi* is selected for export.

You can export a final matte by connecting the input to the matte tab on the Export node. Connecting the input to the front tab on the Export node produces a final result clip.

When you select the Export node, the Image Export controls, Resize controls, LUT Editor, and Queue Manager appear in the Batch menu.

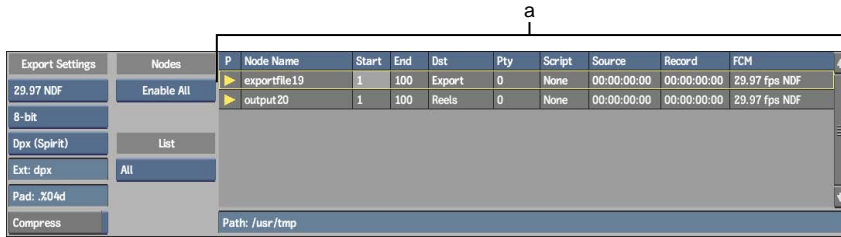

(a) Queue Manager

Field Merge Node

The Field Merge node accepts a front clip. Use the Field Merge node to remove field jitter by merging the fields of a clip. Enter the percentage of blending between fields in the Level field. A value of 100% replicates the average pixel on both the even and odd lines.

This node supports floating-point (OpenEXR) clip input.

See [Merging Fields](#) on page 727.

Filter Node

The Filter node applies different effects to a clip, including textures, blurring, edge detection, embossing, sharpening, as well as a combination of effects.

To load a filter:

- 1 Add a Filter node and attach a front clip.
- 2 Select the Filter node in the schematic.
The menu for the Filter node appears.
- 3 Click Load.

The file browser appears showing a list of filters. These filters are the same filters available in the Filter module and Paint.

- 4 Select a filter.

You return to Batch and the name of the selected filter appears in the Filter box.

NOTE You cannot create or modify filter setups through Batch.

See [Filters](#) on page 1535.

Flip Node

The Flip node accepts a front clip as input. Use the Flip node to generate a mirror image of a clip. Select how you want to flip the clip from the Flip Type box. You can flip the frames in a clip horizontally, vertically, or both.

See [Flipping Images](#) on page 1432.

Glow Node

Use the Glow node to create a glow effect on a clip. Customize the glow by selecting the RGB blur type and blending mode. The Glow Node accepts a front clip and matte clip as input. You can refine your glow further using colour correction, matte restriction, and RGB channel offsets.



Glow and Front Parameters Displays the controls to customize the glow's blur effect. In the RGB Blur Type box, select Gaussian, Box, or Directional to apply a blur and enter blur parameters for the front clip. See [RGB Blur Node](#) on page 1370.

Matte controls Generate and control the matte's behaviour. Enable the Auto Matte button to generate matte values from the front clip. Set the value in the Expand field to enlarge the white area of the matte. Enable Lock Expand to make this value directly proportional to the Width value of the blur.

Blending controls Provides the logical operations that can be used to blend the front and the result. Use the Transparency field to set the percentage of blending when the result is composited on the front clip. See [Using Logical Operations](#) on page 1433.

Colour Correction controls Displays colour correction tools to modify glow colour values. See [Colour Correcting from the Main Menu](#) on page 1467.

RGB Channel controls Displays weighted value and offset of each blurred color channel.

GMask Node

The GMask node accepts a front and a matte clip as input. The GMask node accesses the Garbage Mask menu and includes the Tracer and Region of Interest (ROI) functions, which are found in the Modular Keyer.

You can save and load GMask setups directly in Batch. See [Loading Garbage Mask Setups](#) on page 1758 and [Saving Garbage Mask Setups](#) on page 1757.

GMask node tabs process gaps in clips set to No Media as black frames. An unconnected front clip will return an error, while an unconnected back clip will process black frames.

Import Node

Use the Import node to access the Import Image module, where you can import images and clips directly into Batch. Once imported, the item's start and end frames can be set.

To import images into Batch:

- 1 In the node bin, select the Import node and drag it to the schematic.
The Import Image menu and file browser appear.
- 2 In the Import Image menu, select the file type you want to import from the File Type box.
- 3 In the file browser, select the file(s) you want to import.
- 4 Click Load.

You return to Batch and the filename and file type of the image you import appear in the schematic. The filename and path appear in the message bar when you click the image. Detailed information about the image is displayed below the message bar.

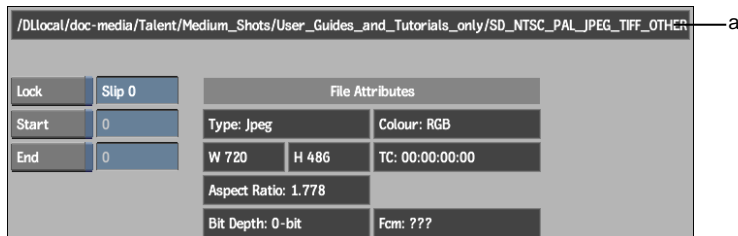

(a) Message bar

NOTE An imported image can be resized or brought into the LUT Editor, which can be accessed from the clip's RGB LUT menu.

If an imported clip or image cannot be found, the missing file is displayed as a checkerboard in the image window.

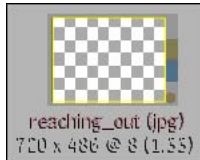

Keyer Node

The Keyer node accepts front, back, and matte clips as input. Before you enter the Keyer module, you can choose to generate a result, matte, or composite clip by selecting the Result, Matte, or Comp view option, respectively, from the Choose Type box before processing.

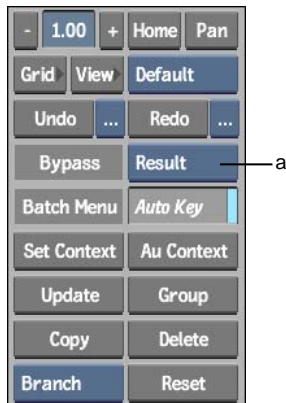

(a) Choose Type box

The Keyer node processes gaps in clips set to No Media based on the input tab receiving the information.

Input	Result
Front	No media
Back	Black frames

Input	Result
Matte	Black frames

When working in the Keyer module, missing media in front clips set to No Media are converted into black frames while they are in the editor. When missing media is output from the Keyer node, it returns to a No Media state.

See [Keyer](#) on page 1545.

Lens Distort Node

Differences in camera lenses or perspective irregularities cause lens distortion that results in skewed angles. You can use the Lens Distort node to rectify or simulate these types of distortions in your images.

To access the Lens Distort node:

- 1 Drag the Lens Distort node to the Batch schematic.
- 2 Double-click the Lens Distort node.

The Lens Distort menu appears.



The Lens Distort controls are described as follows.

Distortion box Specifies whether you perform a lens distortion or rectification. All other radial distortion controls are implemented based on this selection.

Filter box Defines the type of filter for your distortion or rectification.

Resize box Assigns the resize option you choose to apply to your image (if any distortion or rectification is present).

Select: **To:**

No Resize Keep the resolution of the image as is.

Select:	To:
Best Fit	Fit all of your rectified image (in the resolution of the front clip) without showing any black outside of the image.
Fit all	Fit all of your rectified image (in the resolution of the front clip).
Resize Output	Fit your rectified image in a different-sized output without losing any part of the image. If this option is selected, you can choose Optimal Resize, or you can set your preferred Width and Height.

Regen button Indicates whether the image is refreshed while fields are updated.

Centre area Assigns the size of the Centre box in your image. You can also change the colour of the Centre box by using the colour pot beside the Icon button.

After you make a selection in the Centre box, you can use the Centre X and Centre Y fields to move the centre of your image.

Performing a Perspective Rectification

You can rectify an image based on its perspective. You set four-corner source anchor points to features in the image that are distorted by the lens perspective, and map these points to a rectangle or a free-form four-corner destination shape. For example, you can correct a distorted wall by anchoring the points to the wall corners and automatically rectify it to be a rectangle.

NOTE Although you can also perform a perspective distortion, best results usually occur when performing a perspective rectification.

To perform a perspective rectification:

- 1 Select Rectification from the Distortion box.
- 2 Enable Perspective.

Perspective	From	To
Rectangle	X	Y
Upper Left	-0.50	0.50
Lower Left	-0.50	-0.50
Lower Right	0.50	-0.50
Upper Right	0.50	0.50
Relative XY		

3 Select a Perspective type.

Select: To rectify (or distort) by:

To Rectangle Mapping the four-corner source anchor points to a rectangle (you do not have control of the destination rectangle).

Horizontal Preserving the horizontal edges of the original image and rectifying the vertical lines of the four-corner source shape to be vertical.

Vertical Preserving the vertical edges of the original image and rectifying the horizontal lines of the four-corner source shape to be horizontal.

Free Form Mapping the four-corner source anchor points to a free-form four-corner destination shape.

4 Set the Range type.

Select: To set the X and Y range to:

Relative XY -0.5 to 0.5.

Absolute XY Half of the image size.

5 Set the X and Y values for your perspective type. You can also drag the anchor points directly in the image to set the various X and Y values. Use the To and From colour pots to change the colours of the anchor points and guide lines, if needed.

TIP You may find it easier to use two viewports in the image window for this procedure (press **Alt+2**). Use Front view (**F1**) while working with any source shape (yellow anchor points and guidelines), and use Result view (**F4**) while working with a Free Form destination shape (pink anchor points and guidelines).

Rectifying an Image with Spline Analysis

You can perform an automatic rectification of features in the image by computing a new alignment based on splines that you add.

To rectify an image with spline analysis:

- 1 Enable Analyse.

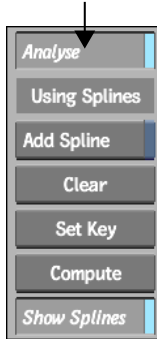

- 2 Click Add Spline.
- 3 Draw a spline in your image along a feature that will be straightened.

TIP Splines are visible in the image if Show Splines is enabled.

- 4 Repeat step 2 to add as many splines as needed. Click Clear to remove all selected splines.
- 5 Click Compute to analyse the image based on the splines you added.
- 6 Click Set Key to set a keyframe based on the result of the analysis.
- 7 Disable Analyse.

8 You can fine-tune your analysis with the radial controls.

Adjust:	To:
Lens Mag	Adjust the magnitude of radial distortion or rectification.
Lens Adj	Fine-tune the radial distortion or rectification.
Anamorph	Stretch your distortion or rectification along the X or Y axis. A value greater than 1.00 stretches more on the X axis, while a value less than 1.00 stretches more on the Y axis.

Library Node

The Library node accesses the clip library, letting you load clips directly into Batch.

To load clips from the clip library into Batch:

- 1 In the node bin, select Library and drag it to the schematic.
The clip library appears.
- 2 Select the library you want to browse. You can browse both local and remote libraries.
- 3 Select the clips you want to load and click Load.
To search the clip library for a specific clip, see [Searching for Clips](#) on page 582.
You return to Batch and the selected clips appear in the schematic.

Logic Op Node

The Logic Op node accepts a front, back, and matte clip. The Logic Op box lists the logical operations that you can perform on the front clip. The Logic Op node menu is similar to the Logic Ops command in the Processing menu.

Operation	Transparency
Add	0.0%

See [Using Logical Operations](#) on page 1433.

The Logic Op node processes missing media in clips set to No Media based on the input tab it is connected to.

Input	Result
Front	No media
Back	Black frames
Matte	White frames

Luminance Key Node

The Luminance Key node creates a matte based on the luminance of an image. A front clip can be connected to the Luminance Key node and will process a result clip that can be used as a matte. In the Modular Keyer, this node can be placed only on a matte branch (blue).

There are two parameters available:

- Tolerance removes greys outside the key shape. A value of 100% generates a completely opaque matte.
- Softness adjusts the softness of the edges of the matte.

These settings can be animated and are available as channels. See [Creating a Key by Setting the Luminance](#) on page 1568.

LUT Editor Node

A LUT converts logarithmic images to linear images or linear images to logarithmic images, while maintaining colour accuracy. The LUT Editor node can also be used to apply a conversion to 16-bit floating-point image in the OpenEXR file format.

When you import or export clips in Batch, default LUT parameters are used and the direction of the conversion is detected automatically. Use the LUT Editor to modify these default settings interactively or to import an existing LUT. You can also export a LUT from the LUT Editor.

When you load an OpenEXR-formatted clip into Batch, you can connect it to nodes that support 16-bit floating-point images. To work with additional nodes, first connect the clip to a LUT Editor node to convert the clip into an 8- or 12-bit linear image. Whether or not you change the clip's bit depth, use

the LUT Editor's EXR Display option to control the image's luminance and black point properties.

The LUT Editor node can be set to output a bit depth of 8, 10, 12, or 16 bits. You can also manually set the variables for output. See [Accessing the LUT Editor in Batch](#) on page 748.

Applying a Conversion to an OpenEXR Image

You can use a LUT Editor node to apply a conversion to an OpenEXR-formatted clip. If a clip is stored at 16 bits, and you want to connect it to a node that does not support floating-point data, attach it to a LUT Editor node to apply a linear conversion to the clip.

To apply a conversion using the LUT Editor node:

- 1 Import or load an OpenEXR-formatted clip stored at 16 bits.
- 2 Drag a LUT Editor node to the Batch schematic and connect it to a clip.
- 3 Select the node.
The LUT Editor appears.
- 4 From the Conversion LUT Type box, select EXR Display.
- 5 To convert the output, select the output bit-depth in the Destination menu.

Master Keyer Node

Use the Master Keyer node to gesturally pull a key. Add a Master Keyer node to the Batch pipeline when you need to create an accurate key of a clip. Use the Master Keyer node to automatically suppress colour spill, to colour correct, and to remove noise or grain. See [About the Keyer](#) on page 1545.

The Master Keyer node accepts front, back, and matte clips as input. While there is no setup menu for the Master Keyer node, it can be saved as part of the Batch setup, or alternatively, as a Custom node. The Master Keyer is also available from the Keyer node.

TIP In order for the hot keys **M** and **D** to correspond to Matte and Degrain, the Master Keyer in Batch must have focus and the viewport cannot be set to a schematic view. If the schematic has focus, then **M** corresponds to Move and **D** corresponds to Delete.

The Master Keyer node processes gaps in clips set to No Media based on the input tab receiving the information.

Input	Result
Front	No media
Back	Black frames
Matte	White frames

Matte Curves Node

Use the Matte Curves node to access the Matte Curves menu, where you can adjust the luminance of input mattes. The Matte Curves node is the same as the Modular Keyer Matte Curves node. See [Result Node](#) on page 1643.

The Matte Curves node processes gaps in clips set to No Media based on the input tab receiving the information.

Input	Result
Front	Black frames
Back	Black frames
Matte	No media

Modular Keyer Node

The Modular Keyer node accepts front, back, and matte clips as input. You use the key-in clip, which is generally the same as the front clip, to create a matte for the front clip. Before you enter the Modular Keyer editor, you can choose to generate a result, matte, or composite clip by selecting the Result, Matte, or Comp view option, respectively, from the Choose Type box before processing.

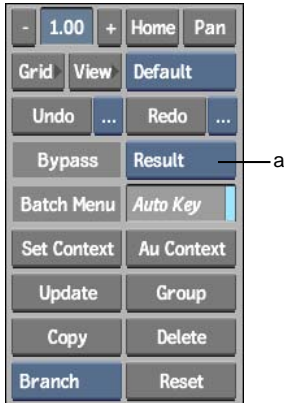

(a) Choose Type box

Click Edit to access the Modular Keyer editor. In the editor, you can save and load Modular Keyer setups directly in Batch. See [Modular Keyer](#) on page 1603.

The Modular Keyer node processes gaps in clips set to No Media based on the input tab receiving the information.

Input	Result
Front	No media
Back	Black frames
Matte	Black frames

Monochrome Node

The Monochrome node generates a monochrome copy of the front clip. Use the Channel box to select the monochrome channel for the clip.

Motion Analysis Node

Attach a front clip to the Motion Analysis node to analyse image displacement in a frame with respect to the frame before it.

This node accepts floating-point (OpenEXR) clip input. Regardless of bit depth, node output for each output tab is a 16-bit floating-point image.

The Motion Analysis node includes two additional views: Forward Flow and Backward Flow. In these views, motion is represented by a colourspace. The colour intensity increases to indicate a larger displacement in the sampled area.

Colour	Type of Motion
Red	Horizontal motion
Green	Vertical motion
Yellow	Horizontal and vertical motion
Black	No motion

TIP In the View menu, you can use the R (Red) and G (Green) buttons in the Viewing area to display one colour at a time.

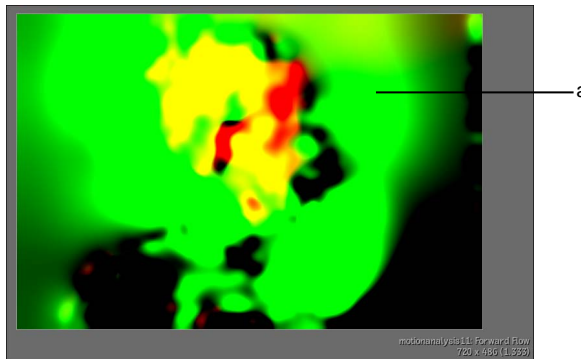

(a) Motion data in the Forward Flow view

Motion analysis accuracy is determined by the Quality parameter: you can process the image at its full resolution, or change the option to increase the processing speed. Forward motion data is output in the upper output tab, and backward motion data is output in the lower output tab.

Forward and backward motion data from this node can be input into the green and blue tabs, respectively, of the Vector Viewer and Motion Blur nodes. See [Motion Estimation Using Batch Nodes](#) on page 1174.

The Motion Analysis node processes frames based on data from preceding and subsequent sample frames. A frame with missing media that is set to No Media may be included in a sample.

Motion Blur Node

The Motion Blur node is used to create a motion-estimated motion blur. You can also create a timewarp, or select a point of reference in a clip and create a motion blur that is relative to the displacement of a selected reference point in the frame.

This node supports floating-point (OpenEXR) clip input. The front tab accepts integer and floating-point clips. The back and matte tabs support floating-point clips only.

When a front clip is the sole input for the Motion Blur node, motion analysis data is calculated using the front clip. To use external motion data, attach forward and backward motion data to the green and blue tabs, respectively. You can attach the upper and lower outputs from the Motion Analysis node or import motion data from another source. See [Motion Estimation Using Batch Nodes](#) on page 1174.

The Motion Blur node processes frames based on data from preceding and subsequent sample frames. A frame with missing media that is set to No Media may be included in a sample.

Input	Result
Current frame set to No Media	Frame set to No Media
Frame with media after gaps set to No Media	Frame using current and next frames
Frame with media before gaps set to No Media	Frame using current and previous frames

Access motion blur controls from the Motion Blur menu.



(a) The Quality option box

Quality option box Determines the motion analysis accuracy. Select Full Res to process the image at the current resolution, or change the option to increase the processing speed. This button is disabled when external forward motion

and backward motion input is attached to the node's forward flow and backward flow tabs.

TW (Timewarp) field Enter the timewarp speed. If the node has external motion data attached to it from a Motion Analysis node, this data is used when calculating motion estimation for the timewarp.

Timing field Enter the source frame to display at the current frame.

You can set the speed and timing of the reference point's motion manually in the Timewarp menu. See [Using the Speed and Timing Curves](#) on page 1363.

Motion Blur button Applies a motion blur to the selected clip.

Samples field Enter the number of frames to sample when creating the blur. The samples include the current frame, and an equal distribution of past and future frames.

Shutter field Enter the number of frames for which the shutter stays open. For example, when the shutter value is set to 3, every third frame will be used as a sample.

Reference button Subtracts the motion blur based on the motion analysis of a reference point at the selected frame. Enable this button to apply the motion blur only to objects that do not have the same relative motion as the selected pixel. This button is enabled automatically when you edit values in the X and Y fields.

The pixel's estimated motion is used as a reference for the direction of the blur for the entire frame. The closer a pixel's motion vector to that of the reference pixel, the less blur it will have.

Reference Colour box Set the colour of the crosshair that marks the reference point in the image window.

X and Y fields Enter the horizontal and vertical position of the pixel to use as a reference point at the selected frame. A reference point can be selected directly in the frame using the cursor.

Using the Speed and Timing Curves

The Motion Blur node has a Speed and Timing curve, similar to the ones in the Timewarp module. Use these curves to modify timing over a sequence of frames to add complex effects to a clip.

The Speed curve and Timing curve are dependent on each other. You cannot change the speed without affecting the timing. When you move a keyframe

on one curve, the other curve moves as well. Enter a value in the TW field to specify the timewarp as a percentage of the source clip.

To use the Speed and Timing curves:

- 1 Create a timewarp using the TW and Timing fields.
- 2 Enter the Channel Editor and adjust the Speed and Timing curves as required.

MUX Node

The MUX (multiplexer) node allows you to make multiple output sockets. Use this node as the input to a group to simplify the representation of a complex effect.

This node supports floating-point (OpenEXR) clip input.

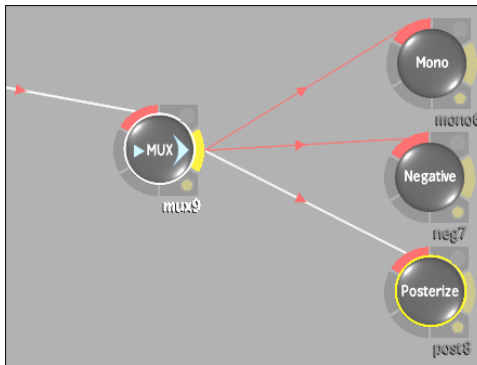

Negative Node

The Negative node generates a negative copy of the front clip. The Negative node does not have a node menu. See [Creating a Negative Clip](#) on page 1440.

This node supports floating point (OpenEXR) data as input.

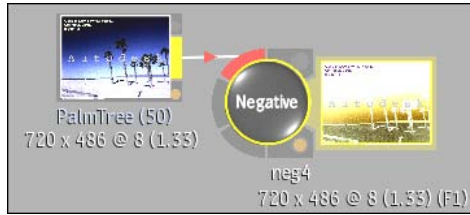

Notes Node

A Notes node creates notes or annotations in the Batch schematic. Notes can be collapsed, moved, resized, or expanded. See [Batch Schematic Notes](#) on page 1271.

Optics Node

The Optics node accepts front, back, and matte clips as input. Use the Optics node to add a glow effect to the clip in the process tree. See [Creating Glow Effects Using Optics](#) on page 1778.

The Optics node processes gaps in clips set to No Media based on the input tab receiving the information.

Input	Result
Front	No media
Back	Black frames
Matte	No media

Output Node

The Output node accepts one video input from any node, and an audio input from any clip with audio. When you select the Output node, the Output Depth box and Queue Manager appear in the Batch menu. You can choose to process the resulting output clip to the desktop reel or the clip library.

When you work with multiple resolutions, the Output node's resolution is determined by the clip or node feeding the Output node. However, you can define the final output resolution, timecode settings, and audio output, as well as the LUT and Resize options.

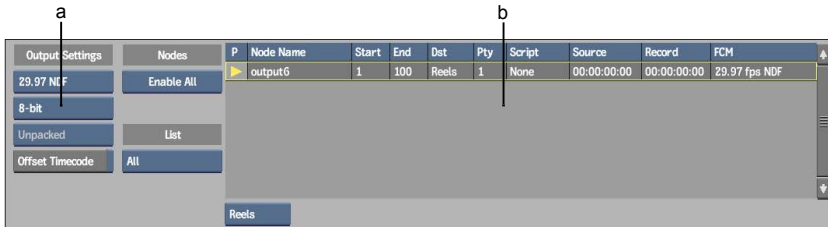
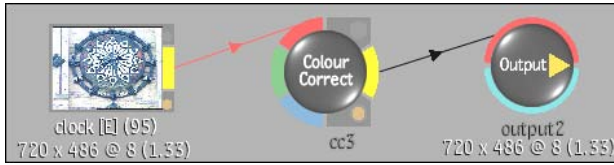

(a) Output Depth box (b) Queue Manager

In the Batch schematic, the audio is connected to the lower (aqua-coloured) half of the Output node. You can assign audio to a rendered clip as well as scrub audio in a clip or play it in real time. You can set where the audio starts on the clip by editing the original clip's audio. The audio will be in sync according to the starting point assigned. You can specify whether to play back native or context audio sources.

You can also scrub your audio context by using **Ctrl** (quick scrub) or **Shift+Ctrl** (real-time scrub) on any node.

Setting the Output Depth

You can set the default output depth used by the Output node from the Output Depth option box.

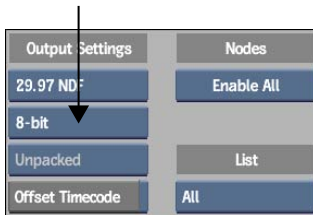

Resizing Your Output

You can resize your output to any resolution. The resolution is not determined by the project (default), but on a node-by-node basis. See [Resize](#) on page 663.

Adding a Timecode to Your Output

You can automatically define a source and record timecode as well as a Frame Code mode for a selected clip's output. You can also do this for multiple clips in the Queue Manager by editing the Source and Record fields.

To add a clip's timecode to an output:

- 1 From the Batch schematic, select the Output node.
- 2 Press and hold down **T**.
- 3 Click a clip.

The clip's timecode and Frame Code mode are transferred to the Output node.

Outputting Media to Cleaner XL

You can output media to Cleaner XL from Batch. See [Exporting Media to Cleaner XL for Encoding](#) on page 264.

To output media to Cleaner XL from Batch:

- 1 Double-click the Output node.

The Queue Manager appears, including controls for Cleaner output.

NOTE The Cleaner encoding option is available only if a Cleaner XL render node has been installed on your Autodesk Backburner Distributed Queueing System (the network rendering system). This would have been installed and configured by your systems administrator. See *Using Cleaner XL with Autodesk Visual Effects and Finishing Applications*.

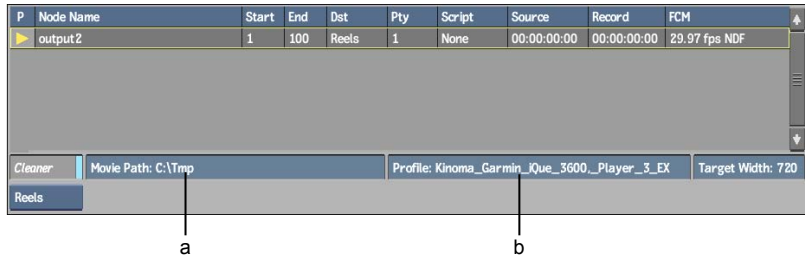

(a) Destination Path field (b) Output Profile field

- 2 Enable the Cleaner button.
- 3 Set an output destination in the Destination Path field, and select an output profile in the Output Profile field.
- 4 Set the width of the Cleaner output in the Target Width field. The clip will be resized before being output using this value. The clip maintains its source aspect ratio to derive a corresponding target height. This function results in a smaller clip being sent through the network to the Windows workstation, reducing bandwidth.
- 5 Process the results.

The clip is sent to Cleaner XL for encoding in addition to being output to the destination as set up in the Output node. If necessary, the clip is first resized to 8 bits, as this is Cleaner XL's upper bit-limit, as well as to the resolution as determined by the value set in the Target Width field.

Paint Node

Batch Paint is a system that provides a scalable matte painting, retouching, or restoration workflow in Batch. Due to its underlying technology, Batch Paint automatically scales strokes when changing the resolution, ratio, or bit depth of input clips, or when switching from Full Resolution to Proxy mode. Batch Paint supports "clipless" setups, which can be applied to any image input while accurately reproducing the sequence of painted strokes.

The Paint node accepts a front and matte clip as input, and creates a result and output matte clip, respectively. You can paint on the result and output matte, with a selection of brushes in different paint modes.

The Paint node also allows you to connect multiple sources and use them to paint the contents of source images onto the result. This paint operation,

applied with the Reveal paint tool, can be used with in-context overlay over the result image. A front and matte clip can be connected as a source by connecting the clips to a source node. The content of source front and source matte input can be used to create brush strokes on the result and output matte.

The Paint node processes missing media in clips set to No Media based on the type of input tab to which it is connected. The node output (including missing media frames) has the same resolution as the Paint setup.

Input	Result
Front	No media
Matte	No media
Source	Transparent strokes

See [Batch Paint](#) on page 2373.

Posterise Node

The Posterise node accepts a front clip and produces a posterised result by reducing the number of luminance or chrominance levels in the clip. The Posterise node menu is similar to the Posterise command in the Processing menu. See [Modifying the Luma and Chroma of a Clip](#) on page 1441.

Quick Composite Node

The Quick Composite node accepts front, back, and matte clips. Use the Quick Composite node to composite a front clip and a back clip using a matte clip. The Quick Composite node menu is similar to the Quick Composite module in the Effects menu. See [Quick Compositing](#) on page 1777.

Resize Node

Use the Resize node to change a clip's resolution, frame depth, and aspect ratio. You can also pan and scan the destination image relative to the source. You can then select and animate the portion of the source clip that appears as the destination clip, and process to create the result image.

This node supports floating-point (OpenEXR) clip input.

TIP You can use [Resize](#) to output, for example, an HD project to a lower resolution for quick viewing.

For more information, see [Resize](#) on page 663.

RGB Blur Node

Use the RGB Blur node to apply a blur filter to a clip. You can animate a blur using the Channel Editor. This node accepts a front clip and a matte clip, and outputs a result and output matte clip. The output matte clip can have a different level of blur than the result clip.

Apply the Regen button to update the image as you change blur settings.

This node supports floating-point (OpenEXR) clip input.

To blur a colour image:

- 1 In the RGB Blur Type box, select Gaussian or Box.



- 2 If you want the image to be equally blurred horizontally and vertically, enable Proportional or hold down the **Alt** key as you change a value. If Pixel Ratio is enabled, the image is blurred using the same proportion as its aspect ratio.
- 3 If you want to use pixels that are proportional to image aspect ratio, enable Pixel Ratio.
- 4 If you want to set the same values for the result and the output matte simultaneously, enable Lock.
- 5 Set the width and height of the blur. Increasing the blur increases the processing time.
- 6 If you want to set the width and height of the blur for the matte in the MHeight and MWidth fields, respectively, disable Lock and set the values.

To create a radial blur:

- 1 In the RGB Blur Type box, select Radial.

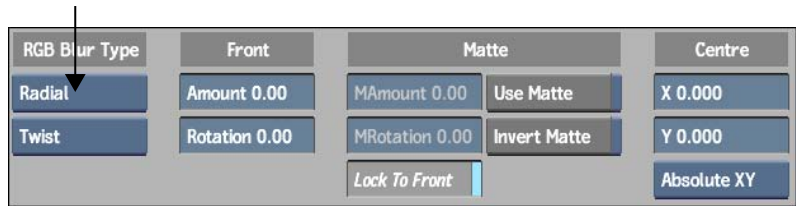

- 2 In the Radial Blur Type box, select Spin to blur pixels in a single direction, or Twist to blur pixels in two directions.
- 3 If you want to set the same values for the result and the output matte simultaneously, enable Lock.
- 4 Set the amount of the blur and the angle of rotation. Increasing the blur increases the processing time.
- 5 If you want to set the amount of the blur and the angle of rotation for the matte in the MAmount and MAngle fields, respectively, disable Lock and set the values.
- 6 Move the red circle on the image to set the centre of the blur. The position corresponds to the X and Y values in the Centre fields.

To create a directional blur:

- 1 In the RGB Blur Type box, select Directional.



- 2 If you want to set the same values for the result and the output matte simultaneously, enable Lock.
- 3 Set the radius amount and angle of the blur (at a default angle of zero, the blur is horizontal). Increasing the blur increases the processing time.

- 4 If you want to set the radius amount and the angle of blur for the matte in the MAmount and MAngle fields, respectively, disable Lock and set the values.

Restricting Blur

You can limit the area of the result image that is blurred using the matte controls.



Use Matte Limits the area where you want to apply the blur on the result image, based on the output matte. Disable to blur the entire image.

Invert Matte Inverts the matte selection, limiting the blur to areas outside the output matte.

Spark Node

Use the Spark node to access the file browser, where you can add Sparks plug-ins to the process tree. The number of inputs and bit depth that a Spark node accepts depends on the Sparks plug-in. A Spark node has light grey source tabs, since each Sparks plug-in varies in the type of clips it uses. When editing a Spark, you can display information on its type by toggling the **F1** and **F4** function keys.

When working in a Sparks plug-in in Batch, missing media in front clips set to No Media can be converted into black frames while they are in use. When missing media is output from this node, it returns to a No Media state, regardless of whether it was set to display differently in the node.

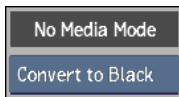

Select:	To:
Pass Through	Keep frames as No Media for the Spark.
Convert to Black	Use black frames when working with nodes that process past and future frames.

NOTE When you attempt to use a Sparks plug-in, the error message “SPARK IS NOT SUPPORTED” may appear. This means the selected Sparks plug-in cannot be used with Batch. Contact the company that developed the Sparks plug-in for information on obtaining a compatible version.

Text Node

Text is comprised of layers, paragraphs, and characters. You can use the Text node in the same way as you use the Text module to make text spin, dance, and change colour over time.

You can enter the Text module with or without a background clip. To enter the Text module with a background clip, you must attach the clip before clicking the Text node.

NOTE The PreRender Text preference does not apply when you access Text from Batch.

To enter the Text module from Batch:

- 1 Click the Text node.

NOTE If a background clip is not connected to the Text node, you select a resolution for the output of the Text node.

- 2 Click Edit.

The Text module controls appear. See [Text](#) on page 1909.

Vector Viewer Node

The Vector Viewer node displays motion analysis data as motion vectors. You can view forward and backward motion vectors, and customize the colour and size of the vectors to make them easier to view. The arrow length displays displacement, and the size of the arrowhead indicates the relative speed of the motion.

This node supports floating-point (OpenEXR) clip input. The front tab accepts integer and floating-point clips. The back and matte tabs support floating-point input only.

You can attach a front clip to the node. Attach forward and backward motion data to the forward flow (green) and backward flow (blue) tabs, respectively.

You can attach the upper and lower outputs from the Motion Analysis node or import motion data from another source. See [Motion Estimation Using Batch Nodes](#) on page 1174.

Access display controls from the Vector Viewer menu.



Forward button Displays the forward motion vectors in the Result view.

Backward button Displays the backward motion vectors in the Result view.

Arrow colour pots Change the display colour of the forward and backward motion vectors.

Grid fields Set the length of the pixel area used to calculate each vector. For example, enter 5 to sample an area of 25 pixels.

Scaling fields Set the size of the motion vectors.

Blend In the Image window, display the previous frame, and set the level of opacity of the current frame. You can verify the displacement of points from one frame to the next when the opacity value is decreased.

Topics in this chapter:

- [About Batch FX](#) on page 1375
- [Creating Batch FX](#) on page 1376
- [Creating One Clip Per Timeline Layer](#) on page 1386
- [Converting Soft Effects to Batch Nodes](#) on page 1388
- [Viewing Batch FX in Context](#) on page 1397
- [Offsetting the Starting Frame of a BFX Clip](#) on page 1400
- [Outputting from a BFX Output Node](#) on page 1402
- [Editing Batch FX](#) on page 1409
- [Navigating Batch Setups](#) on page 1410
- [Expanding Batch FX](#) on page 1417
- [Copying Batch FX](#) on page 1419
- [Deleting Batch FX](#) on page 1420
- [Previewing Batch FX](#) on page 1420

About Batch FX

A Batch effect (FX) is a setup applied directly to one or more segments on the Batch timeline. Batch FX include effects of any module accessed from the Batch node bin. Creating a Batch FX allows you to take a selection of timeline segments into a Batch flow graph environment for procedural compositing. When you create a Batch FX, you perform procedural compositing yet remain in a

timeline-based environment. You can edit and reorder any Batch FX node without affecting anything else in your pipeline.

Each time you create a Batch FX, you enter a new setup for the selected segments. Segments can, therefore, have several levels of nested effects. You can use the BFX View to access a schematic hierarchy of all levels of nested Batch FX and their sources relative to the main Batch timeline. Alternatively, you can expand Batch setups to bring the setups nested inside a clip back to the same BFX level.

Although you can also create soft effects on the Batch timeline, their order in the pipeline is fixed. As well, you can apply soft effects to only one segment. Batch FX give you access to more effects modules than soft effects. Creating soft effects is useful when you want to remain on the timeline and do not need to be in a modular pipeline environment. If you started with soft effects on your timeline and later decide you need the flexibility of the Batch pipeline, you can convert the soft effects to nodes.

You apply a Batch FX to a source or to a source after it has been modified with soft effects. To apply a Batch FX to a source, you enter a Batch setup from a segment's timeline with the Pre option. To apply a Batch FX to multiple sources or to a source modified with soft effects, you enter a Batch setup with the Post option. If you bring multiple layers into a Batch setup and want to apply a separate Batch flow graph to each layer, you can split the layers and create one clip per layer.

When creating Batch FX, you can save the modified clip to the desktop or to the `_Edited` library. See [Managing Edited Clips in Batch](#) on page 1188.

Creating Batch FX

A Batch FX is created by bringing a selection of timeline segments into a BFX level. You enter a BFX level from the main Batch timeline or from the timeline of the clip in the current BFX level. You can bring segments with their soft effects into a BFX level. Batch FX are applied on top of the segments and their soft effects. Or, you can enter a BFX level with a single segment's source, leaving its soft effects intact on the timeline one level up. A Batch FX is applied to the source before anything else affects it.

To apply a Batch FX to segments and their soft effects, you enter a BFX level with the Post option. You can enter with a contiguous selection of horizontal or vertical segments. Bringing in multiple segments is useful for continuing work that was done in context of a timeline or for bringing a selection of segments into the same Batch FX level.

To apply a Batch FX to a source and not its soft effects, you enter a BFX level with the Pre option. You can enter with only one segment. Bring in only a source to make changes such as removing pulldown that you want to do before the soft effects. When you go back to the main timeline, the soft effects are reapplied to the modified source.

A clip can have multiple nested Batch setups. Each time you access a Batch setup, you enter another BFX level. Whether you enter a BFX level from the main timeline or from the current BFX level, you can still enter with the Pre or Post option.

To enter a BFX level with a segment's source:

- 1 Select the timeline segment whose source you want to modify or move the positioner's focus point over the applicable segment.
- 2 Click Pre.

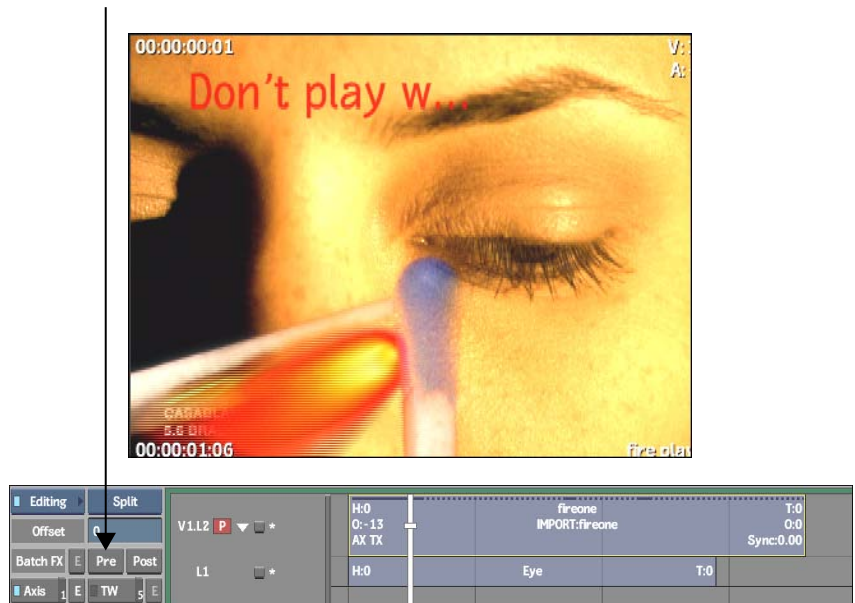

Image courtesy of Casablanca

The segment's source is loaded as a clip in a new Batch setup. In this example, the source segment is brought into a Batch setup without its Axis Key and Text soft effects.



(a) Source segment brought into a Batch setup with the Pre option.

- To display the clip's timeline, select the clip in the schematic and click Timeline. If you do not see the Timeline button, swipe the left side of the screen or double-click the clip.

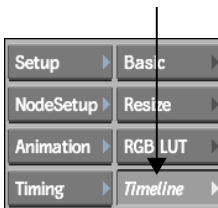

The Axis Key and Text soft effects are not brought into the Batch setup.

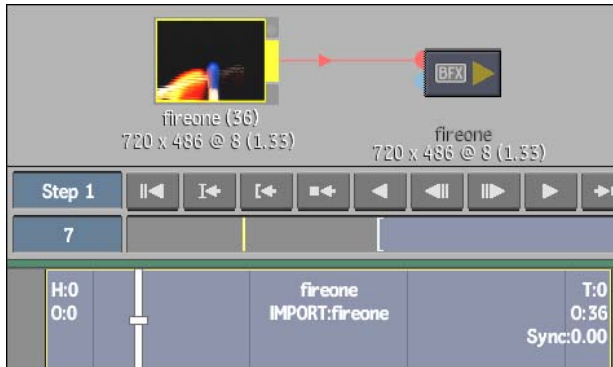

- To modify the source, drag a node to the process tree and adjust the settings. See [Batch: Node Reference](#) on page 1329.

In the following example, a Flip node is applied to the source.

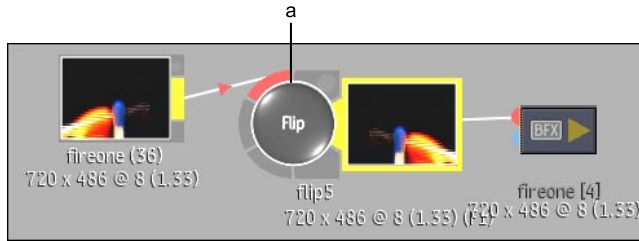

(a) Flip node added to source

TIP To see an updated proxy of the result for a node, enable Auto Update in the Batch Setup menu.

- 5 When you are finished working with the setup, exit to the timeline and process.

Only the source segment brought into the BFX level is modified with the Flip Batch FX. The Axis Key and Text soft effects are reapplied on top of the modified source.

The timeline segment is pale magenta, replacing the original timeline selection. A white BFX icon indicates that a Batch setup is applied exclusively to a source.

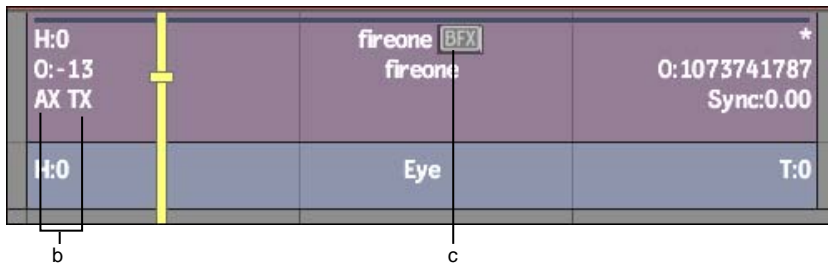

(a) Result clip (b) Axis Key and Text soft effects (c) BFX icon

Image courtesy of Casablanca

Creating Batch FX is an iterative process. Each time you bring a source into a BFX level with the Pre option, the most recently modified source is loaded.

In the following example, the Flip effect is part of the new source segment. If you bring the segment into a new BFX level with the Pre option and create a Batch FX, the setup is applied to the modified source.



(a) New source segment

In addition to applying a new setup to a modified source, you can continue to edit the current Batch setup. See [Editing Batch FX](#) on page 1409.

To enter a BFX level with a segment's soft effects or with multiple segments:

- 1** Select the timeline segments that you want to bring into a BFX level or move the positioner's focus point over the applicable segment.
You can select multiple segments or a specific segment. If you select multiple segments, they must be contiguous horizontally or vertically to enter a BFX level with the Post option. However, it is not necessary to select an entire stack of vertical layers.
- 2** Click Post.

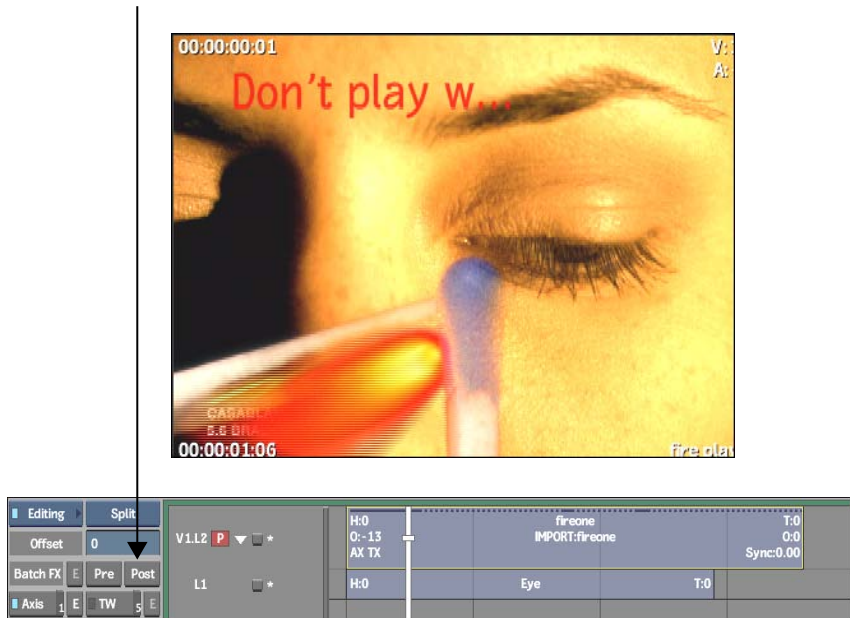

Image courtesy of Casablanca

NOTE If you did not select all the layers of a vertical edit, a message appears stating that vertical compositing may be lost.

The segments along with their soft effects are loaded as a clip in a new Batch setup. In this example, the Axis Key and Text soft effects are brought in with both layers from the main timeline.



(a) Source segment and applied soft effects brought into a BFX level with Post option

- To display the clip's timeline, select the clip and click Timeline. If you do not see the Timeline button, swipe the left side of the screen or double-click the clip.

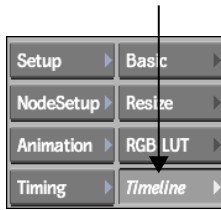

If you did not make an explicit selection on the main timeline and in and out points were set, all segments on all layers between the in and out points are brought in. If in and out points were not set, only the segment under the positioner's focus point is brought in. Head and tail frames are displayed for reference.

The timeline contains the soft effect indicators.

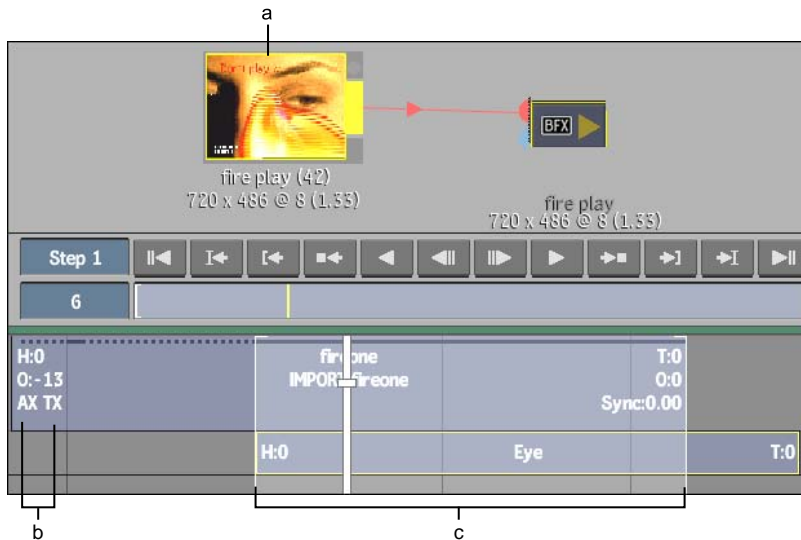

(a) Selected clip (b) Axis Key and Text soft effect indicators (c) In and out points on clip layers

To modify the source and its soft effects, drag nodes to the process tree and adjust the settings. See [Batch: Node Reference](#) on page 1329.

To recreate the vertical compositing of the main timeline as a Batch flow graph, convert soft effects to Batch nodes. In the following example, a Flip node is applied on top of the original front segment and its Text soft effect. When the Axis Key soft effect is extracted from the timeline, it is automatically converted to an Action node and connected to its

corresponding front and back clips. See [Converting Soft Effects to Batch Nodes](#) on page 1388.

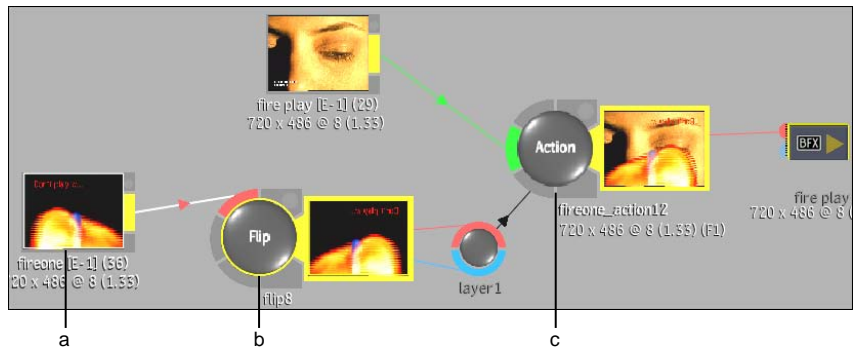

(a) Clip with Text soft effect (b) Flip node (c) Action node

4 When you are finished, exit to the timeline and process.

The Flip Batch FX is applied on top of the original front segment and its Text soft effect. The segment is pale magenta indicating that a Batch setup is applied to the clip. A black BFX icon indicates that the Batch setup is also applied to the clip's soft effects. The soft effect indicators are not displayed because a Batch setup has been applied on top of the soft effects. Enter the Batch setup to access the soft effects.

If you entered Batch with more than one layer, the layers are collapsed into one segment on the bottom layer of the original selection. The segment takes on the length of the original selection or the length defined by the selection's in and out points.



(a) Flip Batch FX applied to clip and Text soft effect (b) Layers collapsed on bottom layer (c) BFX icon

Image courtesy of Casablanca

NOTE You can apply a soft effect on top of a Batch FX segment.

Creating Batch FX is an iterative process. You can apply a Batch FX to a segment in any Batch level. In the following example, the segment with the Text soft effect is brought into a new setup (BFX 2) with the Post option. A Paint node is applied to the clip and its Text soft effect.

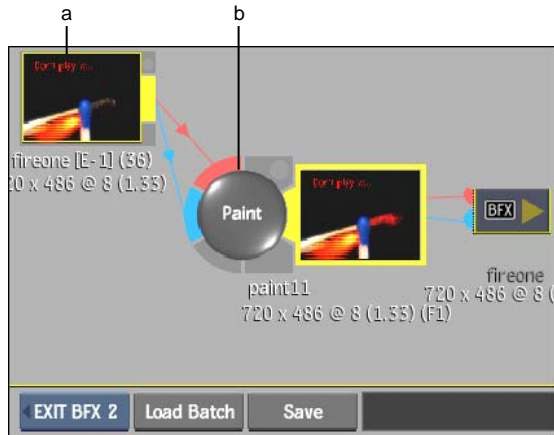

(a) Clip with Text soft effect (b) Paint node

In addition to applying a new setup to a modified source and its soft effects, you can continue to edit the current Batch setup. See [Editing Batch FX](#) on page 1409.

NOTE For a visual representation of all nested levels of Batch FX, use the BFX View. See [Navigating Batch Setups](#) on page 1410.

Creating One Clip Per Timeline Layer

If you bring multiple layers into a Batch setup and want to apply a separate flow graph to each layer, you can split the layers and create one clip per layer. If you want to work with the clips in an Action setup, and they are not affected by vertical compositing from the original timeline layer, you can have each split layer automatically converted to an Action node.

Each clip created from a layer has its own timeline. However, you no longer have access to the timeline of the original clip loaded into the BFX level.

You can split both layers and tracks into individual clips.

To create one clip per layer:

- 1 Load a multi-layer clip into a BFX level.

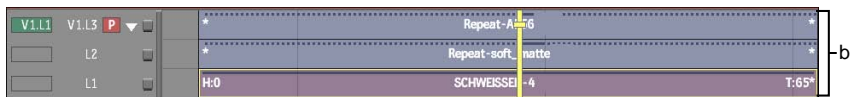
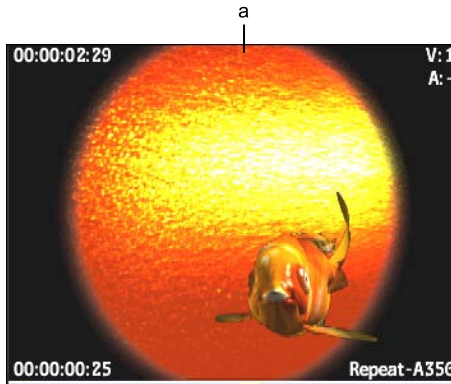

(a) Clip (b) Clip layers

Image courtesy of Quietman

The clip is loaded in a Batch setup with all its layers preserved.

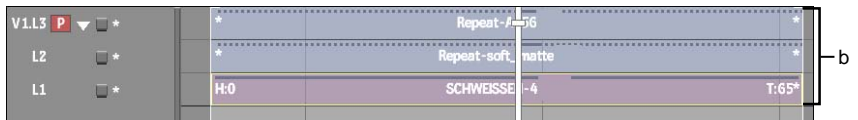

(a) Original clip (b) Layers of original clip

2 Select an option from the Split Layer option box.

Select:	To:
Split Layers	Create one clip for each timeline layer.
Split+Action	Create one clip for each timeline layer and have each clip connected to an Indirect layer of an Action node. Note that any visual result from soft effects may be lost in this operation.

Clips are created for each layer and are connected in the Batch flow graph. The following example shows the result of the Split Layers option.

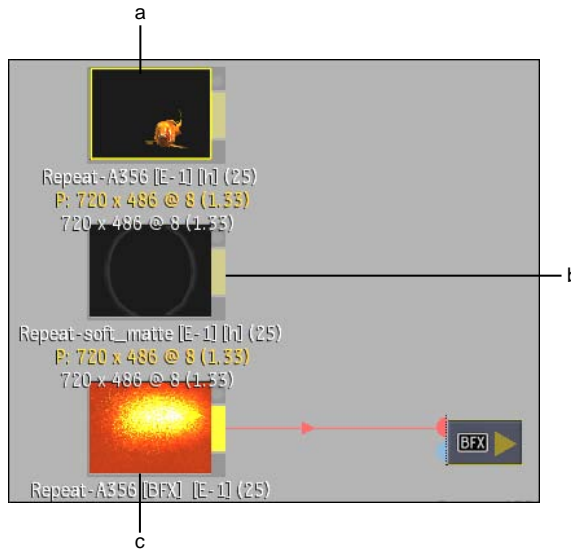

(a) Clip from layer 1 (b) Clip from layer 2 (c) Clip from layer 3

- 3 Add nodes to each clip to create your process tree.

Converting Soft Effects to Batch Nodes

You may have begun compositing in the context of a timeline but would like to continue the work in the modular pipeline environment of Batch. To do this, you can extract or copy the soft effect setups from the timeline to the schematic.

In this workflow, you enter a BFX level with selected segments and their soft effects using the Post option. You then extract the soft effects from the clip's timeline. The soft effects are automatically converted to corresponding Batch nodes and the nodes are connected to their clips.

If you convert soft effects that are composited on multiple layers on the timeline, vertical editing between the layers is reproduced.

You can edit any of the converted node setups as well as reorder nodes in the process tree.

Soft effects are converted to the following nodes.

Soft Effect	Corresponding Batch Node
Soft CC	Colour Corrector
Soft Text	Text
Timewarp	You cannot convert a Timewarp soft effect. To modify the settings, use the editor.
Wipe	Action Keyer, with Garbage Mask setup. Depending on other effects that are part of the extracted segment, the wipe visual results may not be the same as before the extraction. However, the Wipe settings and timing are still loaded into the extracted node.
Spark	Sparks
Blend	Mix
Resize	Resize
Soft Axis	Action, with an Indirect layer
Gap effect	Gap effects are converted to their corresponding Batch node and the extracted layer is converted to an Action node.
Transitions	Dissolve transitions are converted to Action nodes with an Indirect layer. However, dissolves create unexpected results after conversion.

Examples of Soft Effects Converted to Nodes

When you extract a soft effect, segments or other soft effects may also get extracted so that vertical editing from the timeline is maintained. Some of these scenarios are illustrated in the following examples.

The resulting schematics in the examples may vary depending on the RGB and Matte Key settings of the Text soft effects.

If a clip contains only one segment and it is not part of a vertical edit, only the soft effect is extracted and its corresponding node is automatically connected to the original clip.

Example 1: Extracting a Text soft effect from a segment not part of a vertical edit:

- 1 Select the timeline segment with the soft effect that you want to extract.
In the following example, the selected segment is not part of a vertical edit. The segment has a Text soft effect.



V1.L2	P		*	H:0	yellow_flower	T:20	*	Repeat-flower_budding	*
				0:0	IMPORT:yellow_flower	0:30	0:0	VIRTUAL:Repeat-flower_budding	0:0
					TX	sync:0.00			Sync:0.00
				R:00:00:00:19		R:00:00:01:18	R:00:00:01:19	L:00:00:01:03	R:00:00:02:21
L1			*					H:2 Repeat-roses_r...	*

a

(a) Selected segment with Text soft effect

- 2 Bring the segment into a BFX level with the Post option.
The segment you selected is loaded as a clip in a Batch setup. All applied soft effects are brought in with the clip.
- 3 To display the clip's timeline, select the clip and click Timeline. Then **Ctrl**-drag the Text soft effect indicator from the clip's timeline to the schematic.

NOTE If you do not see the Timeline button, swipe the left side of the screen or double-click the clip.

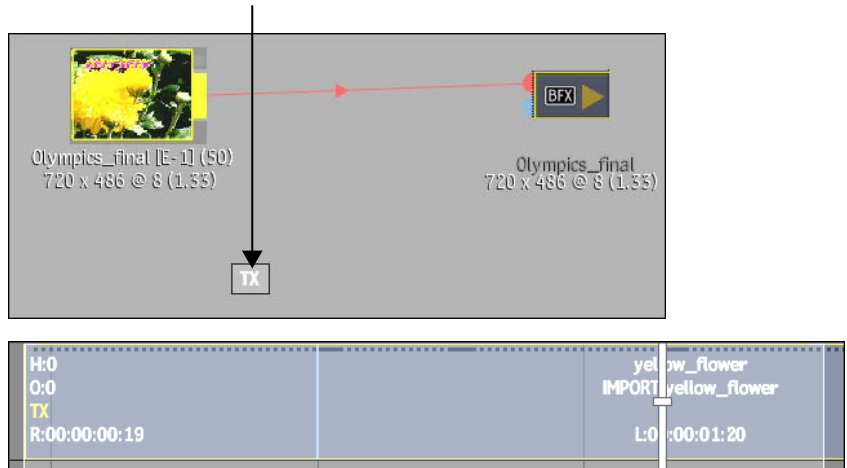

The Text soft effect is converted to a Text node. The node is automatically connected to the clip brought into the BFX setup.

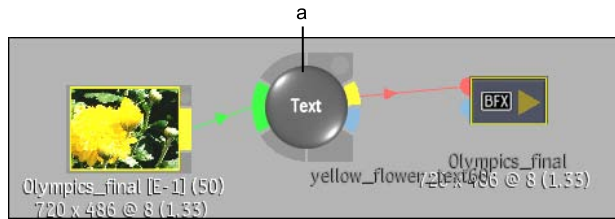

(a) Text node converted from Text soft effect

- 4 Use the Text node to modify the Text setup or to connect to other clips.

If you enter a BFX level with all segments that make up the vertical edit and then extract soft effects, the corresponding segment becomes a new clip and is automatically connected to the extracted soft effects.

Only the selected soft effects get extracted if there are no other soft effects affecting the vertical edit.

Example 2: Extracting soft effects on segments that make up a complete vertical edit:

- 1 Select the segments making up the vertical edit on the timeline.

In the following example, the front layer on the timeline is keyed over a background layer with an Axis soft effect. The front layer also has a Text soft effect.

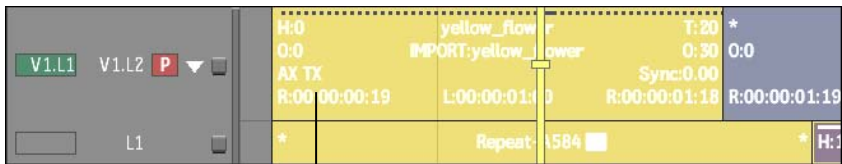

a

(a) Axis and Text soft effect indicators

- 2 Bring both segments into a BFX level using the Post option.
Both segments are loaded in a Batch setup as a single clip with their soft effects.
- 3 To display the clip's timeline, select the clip in the schematic and click Timeline.

NOTE If you do not see the Timeline button, swipe the left side of the screen or double-click the clip.

The imported timeline layers and their soft effects are preserved.

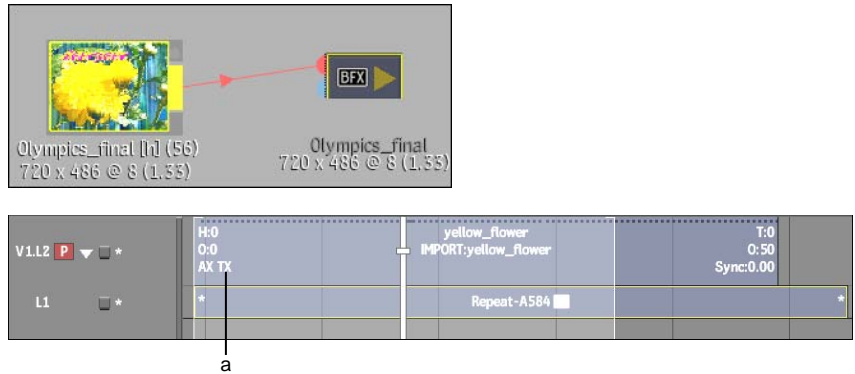

(a) Axis and Text soft effect indicators

- 4 **Ctrl**-drag both soft effect indicators from the clip's timeline to the schematic.
- 5 The extracted soft effects are converted to nodes and their corresponding segment becomes a new clip. The nodes are connected together in the order of the soft effects pipeline.

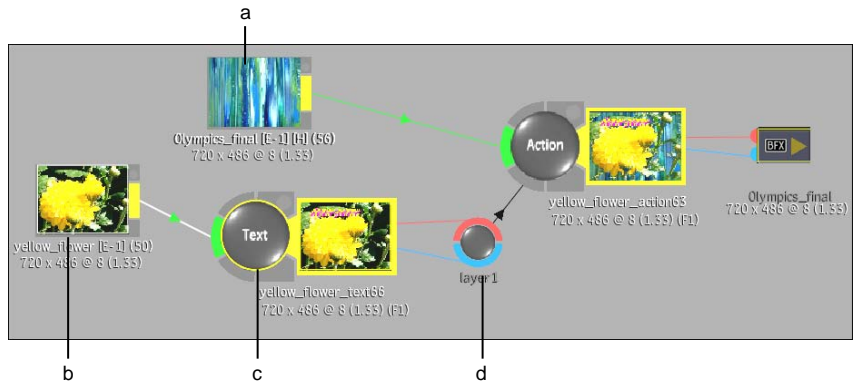

(a) Original clip (b) New clip (c) Text soft effect converted to Text node (d) Axis soft effect converted to Action node with indirect layer

NOTE In this example, if you extracted only the Text soft effect, you would get the same result. The Action node would also get extracted because its segment is part of a vertical edit.

- 6 Use any of the nodes to modify the setups or to connect to other clips.

If you extract a soft effect from a segment that is part of a vertical edit, everything above the extracted segment is also extracted so as to preserve the same visual result. In this workflow, you enter a BFX level with all segments that make up the vertical edit.

Example 3: Extracting soft effects on segments that are part of a vertical edit:

- 1 Select all the segments making up the vertical edit on the timeline.

In the following example, layer 4 has an Axis and a CC soft effect, layer 3 has an Axis soft effect, and layer 2 has an Axis and a CC soft effect.



Layer	Track Name	AX	CC	Sync	Start	End
V1.L4	Repeat-butterfly	0:0	0:35	0:00	00:00:03:04	00:00:03:21
	VIRTUAL:Repeat-butterfly					
L3	yellow_flower	0:0	0:50	0:00		
	IMPORT:yellow_flower					
L2	Repeat-red_flowers	0:0	0:53	0:00		
	VIRTUAL:Repeat-red_flowers					
L1	Repeat-flowers_blue					

(a) Layer 4 (b) Layer 3 (c) Layer 2

- 2 Bring the segments into a BFX level using the Post option.

The segments you selected are loaded as a clip in a Batch setup. All applied soft effects are brought in with the clip.

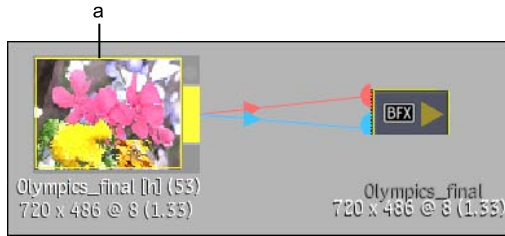

(a) Clip with soft effects

- To display the clip's timeline, select the clip and click Timeline.

NOTE If you do not see the Timeline button, swipe the left side of the screen or double-click the clip.

All applied soft effects are preserved on the imported segments.

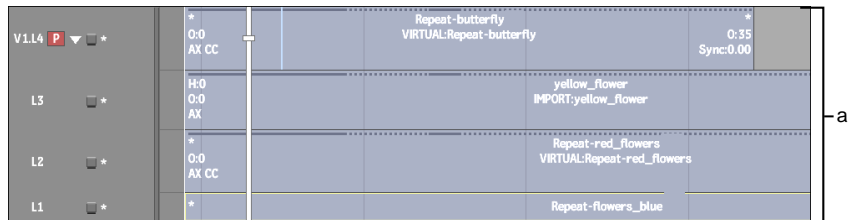

(a) Clip layers and soft effects

- Ctrl**-drag the soft effect indicators to the schematic.

In the following example, the Axis soft effect from layer 3 is extracted. Layer 3 is affected by the compositing of the soft Axis from layer 4. As a result, extracting the soft effect of layer 3 automatically extracts the segments of both layers 3 and 4 to rebuild the visual result in an Action setup. The CC soft effects remain on the layers.

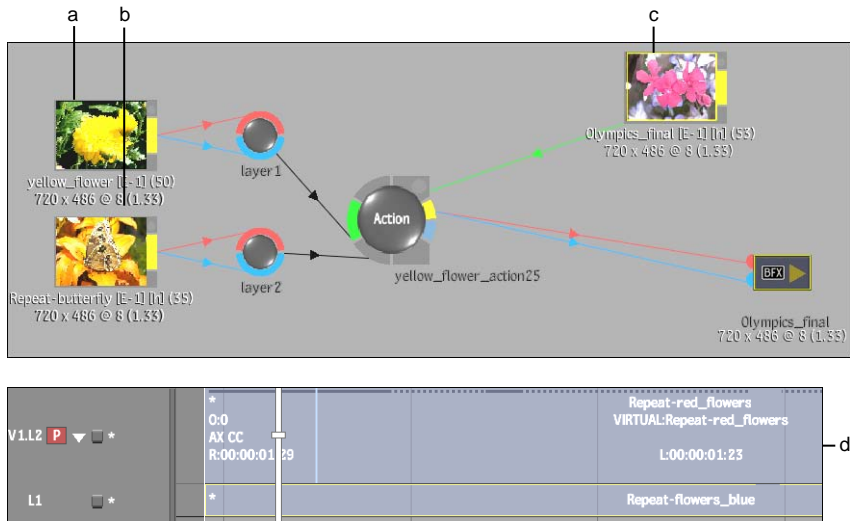

(a) Clip from layer 3 (b) Clip from layer 4 (c) Original clip (d) Timeline of original clip

5 Use any of the nodes to modify the setups or to connect to other clips.

Copying Soft Effects to a Batch Setup

To apply the setups of a soft effect to another Batch clip, copy the soft effect from a BFX segment to the Batch schematic. Only the soft effect is converted to the corresponding node. The original segment and soft effect remain unchanged on the timeline.

To copy a soft effect setup to the schematic:

- 1 Press **Ctrl+Shift** as you extract the soft effect from a Batch segment to the schematic.

The copied soft effect is converted to its corresponding node. The original soft effect and all segments remain unchanged on the timeline.

- 2 Link the corresponding node to a clip in the process tree.

Viewing Batch FX in Context

View the current Batch FX in context of other setups applied to the clip. You can display the result of the current Batch FX in context of the vertical editing one level up in the pipeline. You can also display the result of the current Batch FX in context of your final output.

The following example illustrates context views for two levels of Batch FX.

In the following illustration, the main timeline has two layers. The top layer contains a gap with a Text soft effect.

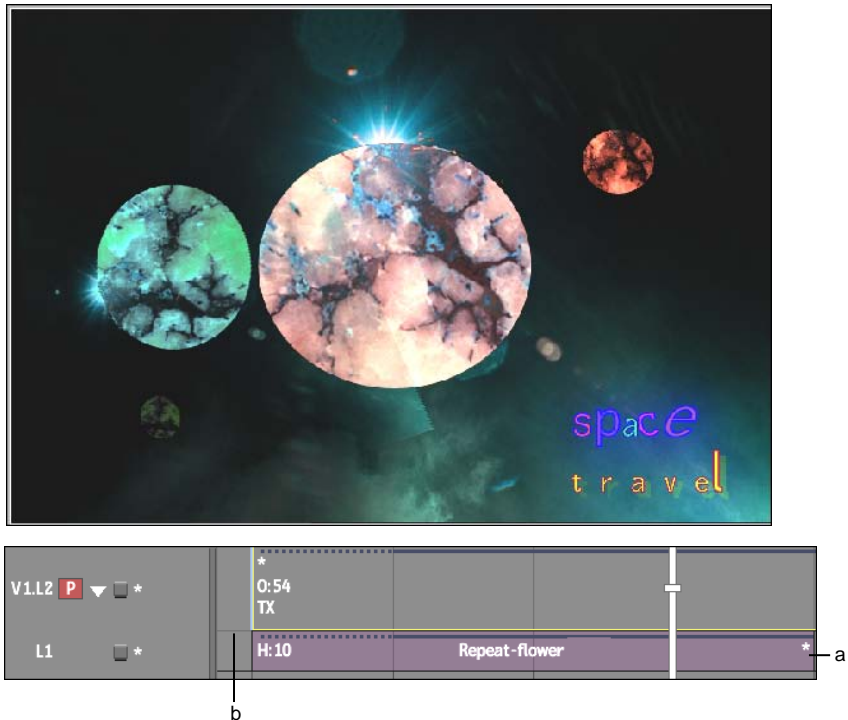

(a) Text soft effect indicator (b) Bottom layer

Image courtesy of Das Werk

In the following illustration, the bottom layer from the main timeline is brought into a BFX level with the Pre option. Next, a layer is added to the clip's timeline on V1.L2. An Axis Key soft effect is then added to V1.L2. A Filter node is connected to the clip in the BFX setup.

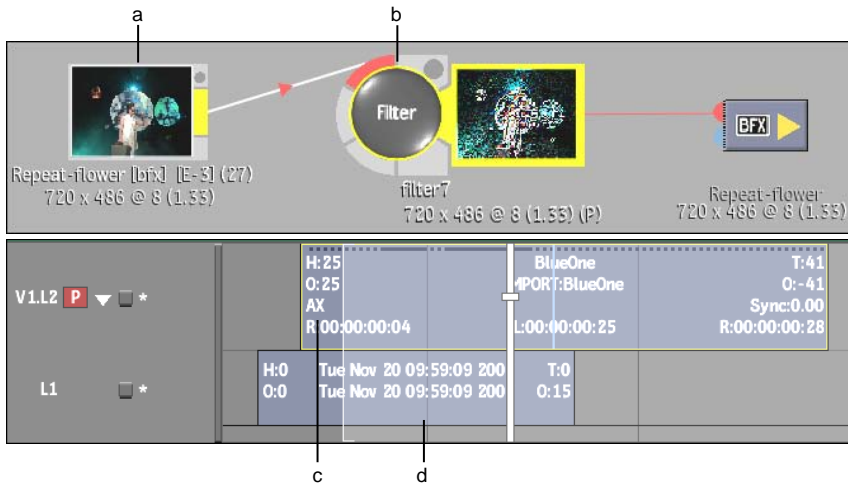

(a) Clip with original layer and new layer (b) Filter node (c) New layer with Axis Key soft effect (d) Original layer

In the following illustration, the bottom layer from the clip in BFX 1 is brought into a second BFX level with the Pre option. A Flip node is then added to the clip.



(a) Flip node

The following illustration is of BFX level 2 with the C: Main level context view selected. C: Main level displays the entire output back to the main timeline. You see the results of the Flip node from BFX 2, the Filter node from BFX 1, the new layer with its Axis Key from BFX 1, and the Text soft effect from the main timeline.

NOTE To display C:Main level context view, select C:Main level from the View box (or press **Alt+Shift+1**).



Image courtesy of Behavior Communications Inc., Das Werk

NOTE To see the entire output, the focus point of the timeline positioner must be on the topmost layer in the main timeline.

The following illustration is of BFX level 2 with the C: Level-up context view selected. C: Level-up displays the result of the current setup in context of vertical editing one level up. You see the results of the Flip node in the current setup and the new layer with its Axis Key soft effect in the timeline one level up.

NOTE To display C:Level-up context view, select C:Level-up from the View box (or press **Alt+Shift+2**).



Image courtesy of Behavior Communications Inc., Das Werk

NOTE The focus point of the timeline positioner must be on the topmost layer in the timeline one level up to see the results.

When you exit back to BFX 1, Level-up view is not available because it provides the same visual result as Main level.

Offsetting the Starting Frame of a BFX Clip

When you load a clip in a BFX level, its timecode automatically keeps the timecode of the main timeline. Both the clip timeline positioner and the Batch timeline positioner represent the main timecode for the current frame. If the clip brought into a BFX level has head frames, they are loaded as negative frames in the Offset field. You can offset the starting frame of a clip using these extra frames.

You can set the Batch timeline to display or hide negative frames. In the following example, a clip with 14 head frames is brought into a BFX level at timecode 00:00:03:16. The Batch timeline does not display negative frames.

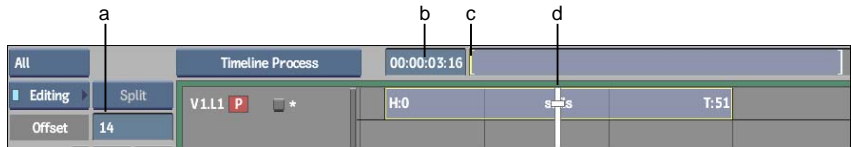

(a) Head frames (b) Timecode of clip from main timeline (c) Batch timeline positioner at frame 1 (d) Clip timeline positioner at frame 1

In the next example, the Batch timeline is set to display negative frames. The Batch timeline positioner changes location to take into account the negative frames. Display negative frames if you need the extra frames for editing.



(a) Timecode of clip from main timeline (b) Batch timeline positioner at frame 1 (c) Clip timeline positioner at frame 1

To set the Batch timeline to display negative frames:

- 1 In the Batch Setup menu, enable Show Neg Frame.

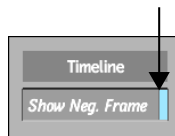

To offset the starting frame of a clip:

- 1 Select a clip in the Batch schematic.
- 2 Enter a value in the Offset field for the starting frame of your clip.



The clip changes location on the timeline based on the new starting frame. The offset is also reflected in the Offset field in the Timing view.



1 (a) Batch timeline positioner at frame 1 (b) Clip timeline positioner at new frame 1

Outputting from a BFX Output Node

Output both matte and RGB results from a BFX output node to the timeline. Use the matte output results with Axis and Sparks soft effects for vertical compositing.

Using the dual inputs of the BFX output node, work in parallel with both front and matte clips from a BFX level. You can create a matte using any Batch node, in any order. You can also output the matte to the desktop for use in other applications or modules.

You can output a matte from a BFX level entered with the Pre or Post option. If you extract a soft effect from a matte segment, the Batch FX containing the matte setup is also expanded.

Outputting a Matte to the Timeline

Output a matte in addition to the RGB result from a BFX output node. You connect the RGB result to the front input of the BFX output node, and the alpha result to the matte input of the BFX output node. Both results are fed directly to the timeline. To enable the matte, you apply an Axis or a Sparks soft effect to the segment.

Alternatively, you can have an Axis soft effect automatically added on output. Enable the Add Axis On Matte Output button in the Timeline section of the Preferences menu.

To output a matte from a BFX output node:

- 1 Enter a BFX level and create a matte. Connect the RGB and alpha outputs to the BFX output node.

In the following example, a basic matte is created with a Keyer node. The blue tab on the BFX output node receives the alpha result and the red

tab receives the RGB result. The background is not considered when you output the matte back to the timeline.

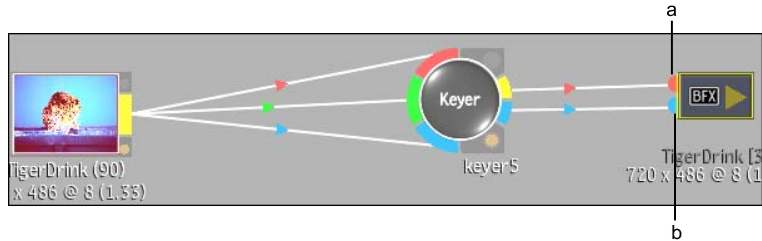

(a) RGB result goes to front input tab (b) Alpha result goes to matte input tab

- 2 Select the BFX output node and press **F4** twice to display the matte and refine as needed.

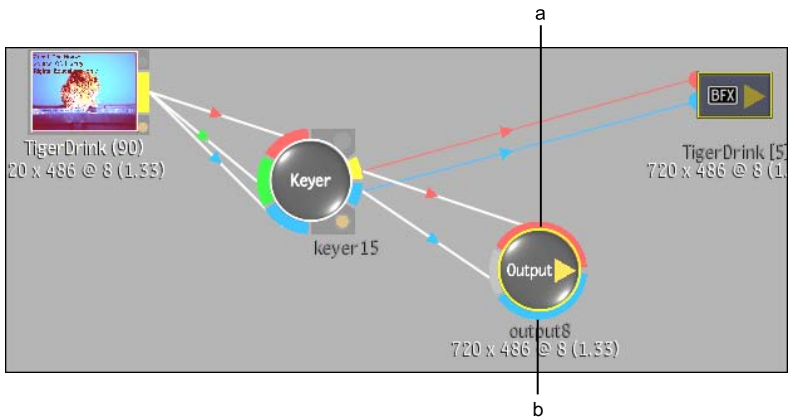

Image courtesy of The House

- 3 If you want to output the matte to the desktop in addition to the timeline, add an Output node. Connect the Keyer outputs to the red and blue tabs of the Output node.

NOTE

The matte input of the BFX output node outputs the matte only to the timeline.



(a) Front input tab of Output node (b) Matte input tab of Output node

4 Exit back to the timeline.

The BFXA icon indicates that the segment contains a matte. In the following example, the matte is not yet enabled (the Add Axis On Matte Output button is not enabled in the Preferences menu).

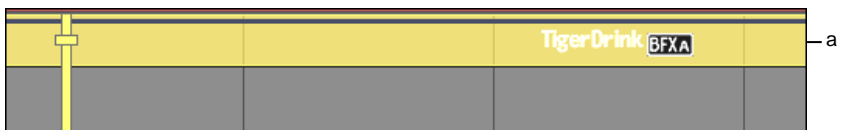

(a) Matte BFXA icon

Image courtesy of The House

- 5 Add a soft Axis to the matte segment and a background layer to the timeline.

NOTE To have the Axis soft effect automatically added when you exit back to the timeline, you can enable the Add Axis On Matte Output button in the Preferences menu at any time.

The matte output results from the BFX output node are composited over the background layer of the timeline.

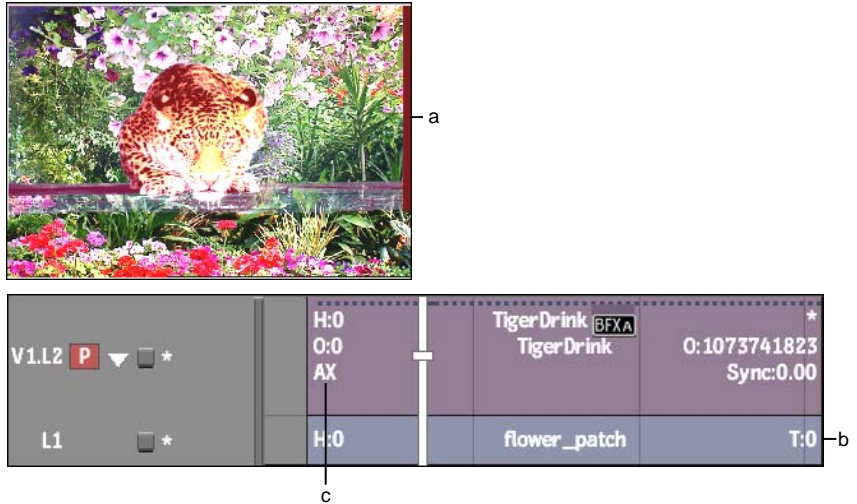

(a) Result of matte from BFX output node keyed over timeline background layer
(b) Timeline background layer (c) Axis soft effect

Image courtesy of The House

- 6 Process and exit to the desktop.

The matte clip and the result of the matte composited over the timeline background are processed from the Output node to the desktop. The matte clip has `_alpha` appended to the clip name.

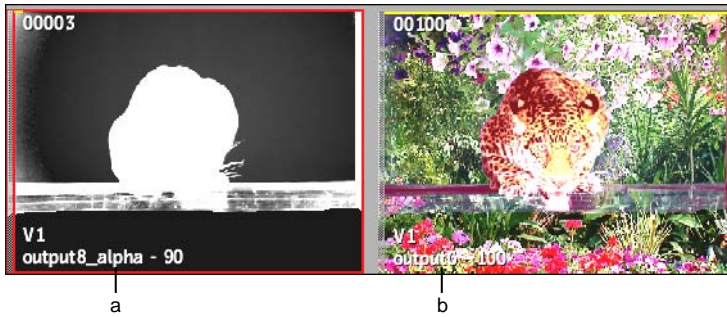

(a) Matte clip (b) Result clip

Image courtesy of The House

Example: Working with a Matte and RGB Result in a BFX Level

The following example illustrates how you can work with both a front clip and matte clip at the same time in a BFX level.

First, create the setups for the front clip. Attach the process tree for the RGB clip to the front input tab of the BFX output node.

When you are finished the front clip, copy the applicable nodes and attach them to the matte clip. There is no need to recreate the setups for the matte. Add nodes to the matte for the required effect. Attach the process tree for the alpha clip to the matte input tab of the BFX output node.

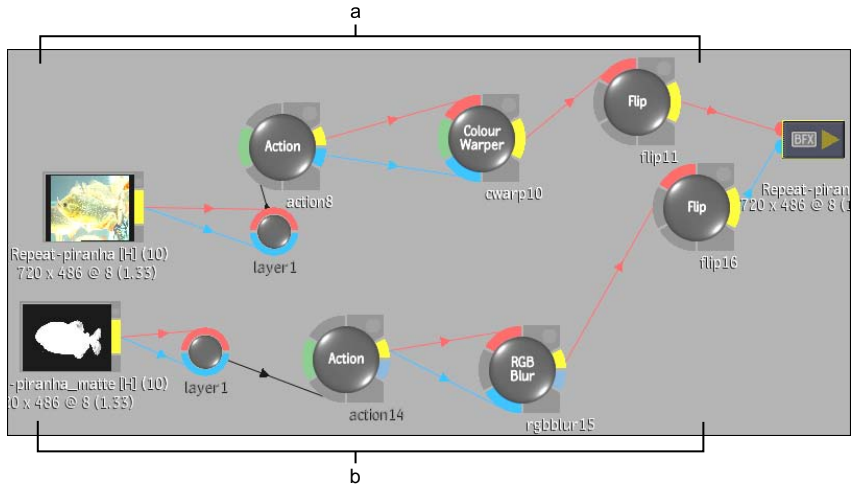

(a) Process tree for front clip (b) Process tree for alpha clip

As you work with your setups, press **F4** once to see the RGB result.

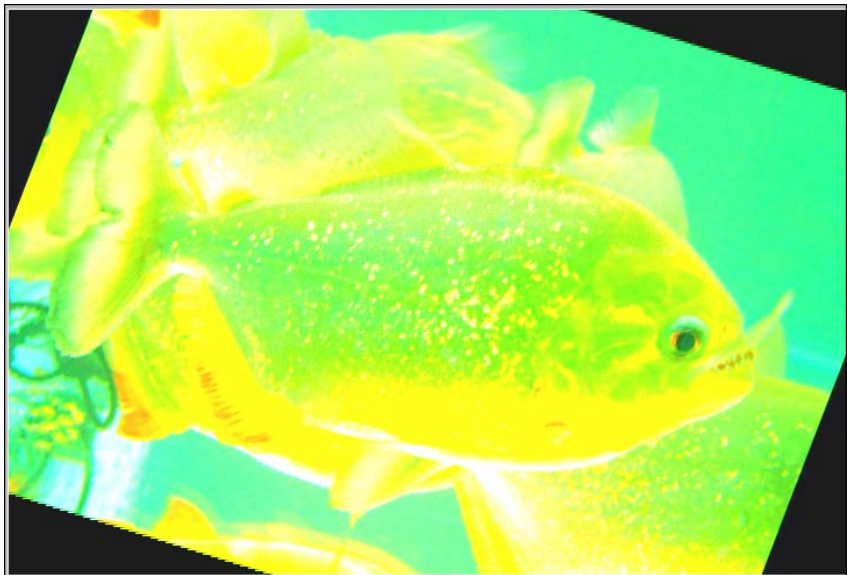
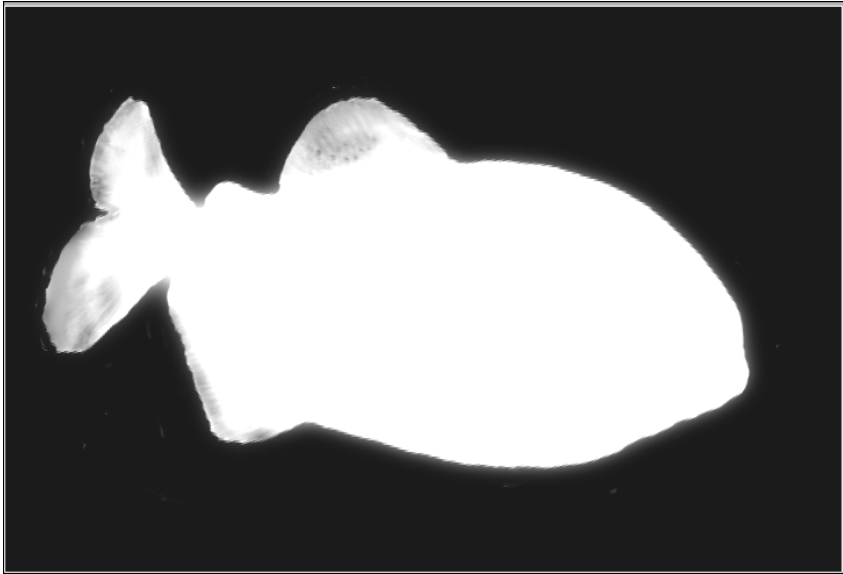

Image courtesy of Technicolor (formerly Toybox)

Press **F4** a second time to see the alpha result.



Back at the timeline level, add an Axis soft effect to the RGBA clip that is output from the BFX output node. The RGBA clip is composited over the timeline's background layer.

NOTE To have the Axis soft effect automatically added when you exit back to the timeline, you can enable the Add Axis On Matte Output button in the Preferences menu at any time.



Image courtesy of Technicolor (formerly Toybox), Digital Lab

Editing Batch FX

You can edit any Batch FX until it is committed by accessing its setup. Access setups in the following ways:

- Directly from the timeline to edit the Batch FX of the current clip.
- From the BFX View to see the hierarchy of the BFX levels and the clips in each level. See [Navigating Batch Setups](#) on page 1410.

You can edit a Batch setup applied to a source or you can edit a Batch setup applied to a source and its resulting soft effects.

To edit the Batch setup applied to the current clip:

- 1 From the clip's timeline, double-click the segment with the BFX icon or select the segment and click E.

NOTE If you are already in a Batch FX level, double-click the clip in the schematic to display its timeline.

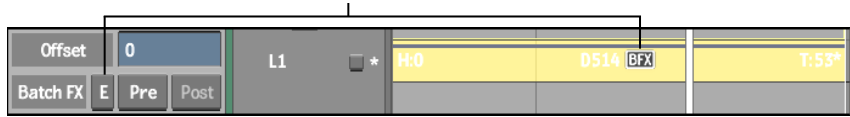

The Batch setup appears. If the BFX icon on the selected segment was white, the source is loaded. If the BFX icon was black, the source modified by the applied soft effects is loaded.

- 2 Edit the settings, exit, and process.

Navigating Batch Setups

Batch FX supports nesting of BFX levels. When you create a Batch FX, you can be in any nested BFX level. The BFX View provides an overview of the source clips and different levels of Batch FX applied to a segment, allowing for quick access to any Batch setup.

With the BFX View, you do not have to remember at which level a Batch FX is nested. You have access to all nested levels relative to the main Batch timeline directly from the BFX View schematic. If you create new setups or add clips to a setup, the BFX View automatically updates to reflect these changes. To help keep track of your work, you can rename setups and source clips within the BFX View.

The BFX View is reset if you process a BFX segment through a desktop module.

You can also match any source clip used in a BFX segment from the BFX View without having to go to the actual Batch FX setup.

To navigate Batch setups:

- 1 Select a BFX segment on the timeline and click BFX View.

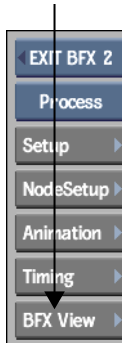

The BFX View displays a schematic of the Batch FX and clips belonging to the BFX segment. Each Batch setup is represented by a Batch FX icon. Yellow Batch FX letters represent the current setup. An orange border around the icon represents the selected setup or clip.

An icon with a red border represents a record clip, which may contain multiple soft edits and multiple layers. An icon with a green border represents a source clip.

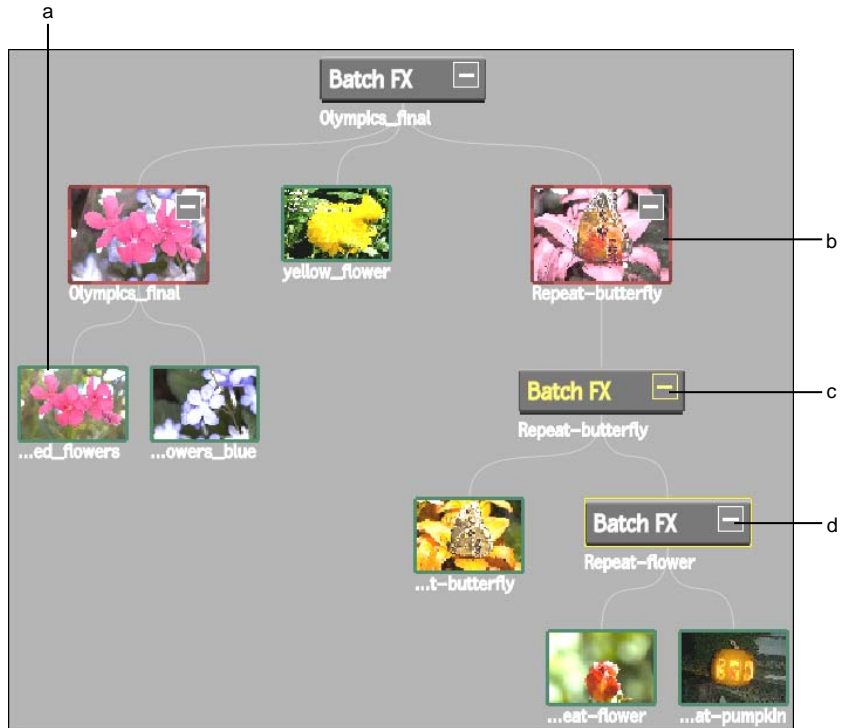

(a) Source clip (b) Record clip (c) Current Batch setup (d) Selected Batch setup

NOTE Batch FX in containers are grayed out because you cannot access them through the BFX View.

- 2 To access the setup of a Batch FX, do one of the following:
 - Double-click a Batch FX icon.

NOTE If the BFX View is crowded, click the minus sign (-) to collapse one of the BFX levels. You can also **Ctrl**+swipe the bottom of the screen to enlarge the BFX View.

- Select the Batch FX icon and then click Edit Batch FX.

The Batch setup appears.

- 3 When you have finished making changes, click EXIT BFX (n) to return to the previous BFX level, or select EXIT Batch.

The BFX View displays any new setups or source clips.

To rename a Batch setup or source clip in the BFX View:

- 1 Select a Batch FX icon or source clip in the BFX View.
- 2 Enter a name in the BFX Name field.

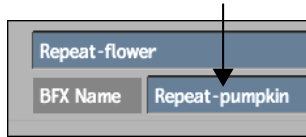

To locate a clip in the BFX View from the schematic:

- 1 **Alt**+click the clip in the schematic.
An orange border appears around the corresponding clip in the BFX View.

NOTE To display the BFX Name field of the clip in the BFX View, click the clip inside the BFX View.

Matching and Copying Sources from BFX View

In the BFX View, you can match sources used in any BFX level without navigating to the actual Batch FX setup. You can also quickly copy sources used in one BFX level to any other level.

You bring sources into a BFX level from Batch timeline segments.

When you copy a source, the timing of the segment on the record timeline is kept as well as any soft effects applied to the segment.

When you match a source, the timing of the segment on the record timeline and any soft effects applied to the segment are not copied. Only the actual source is matched.

To copy a source:

- 1 Select the source clip to copy from the BFX View.

NOTE You cannot select clips within containers.

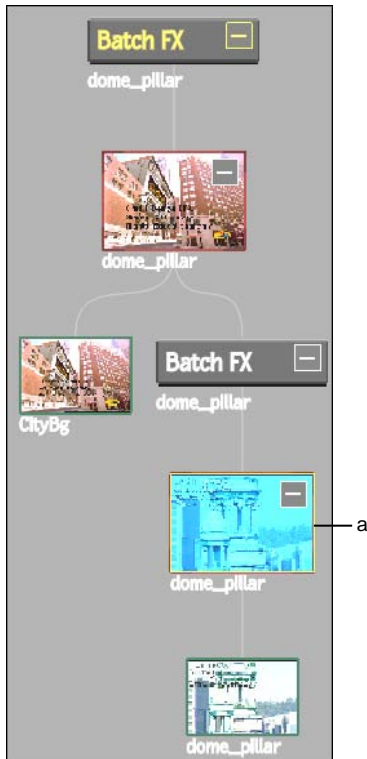

(a) Selected record clip with soft effects

2 Click Copy.

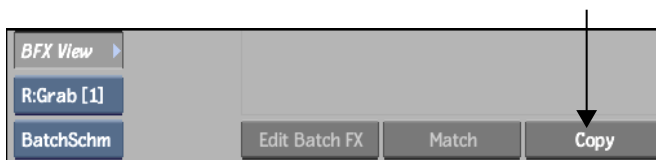

If you accessed the BFX View from a BFX level, a copy of the source clip, including any soft effects applied to its timeline segment, appears in the Batch schematic and in the BFX View at the current BFX level.

If you accessed the BFX View from the main Batch timeline, a copy appears only in the schematic.

The copy keeps the timing of the segment on the original timeline.

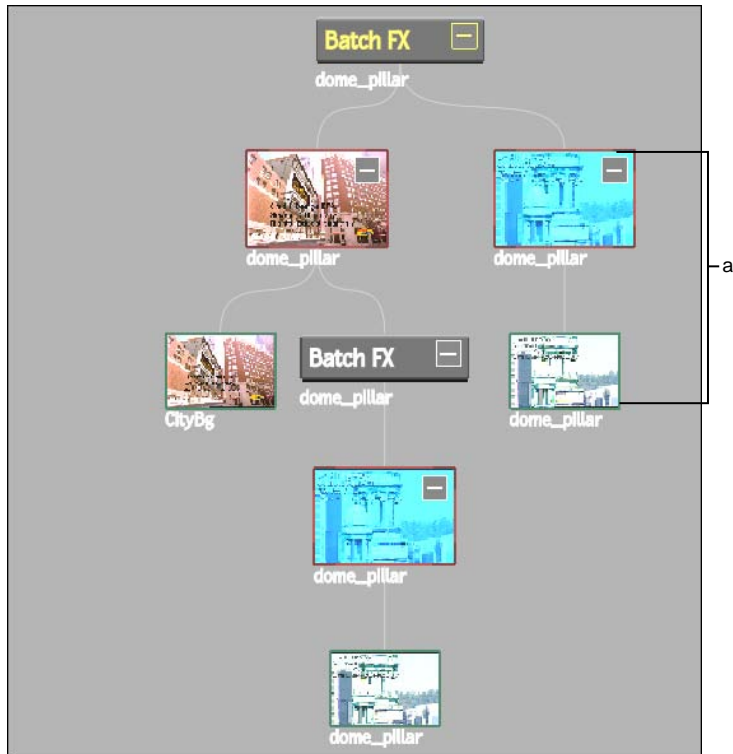

(a) Copied clips with soft effects in BFX View

To match a source:

- 1 Display the BFX View.
- 2 Select the source clip to match from the BFX View.

NOTE You cannot select clips within containers.



(a) Source clip to match

3 Click Match.

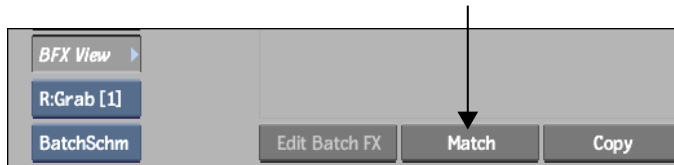

If you accessed the BFX View from a BFX level, a copy of the source clip with its original timecode appears in the Batch schematic and in the BFX View at the current BFX level.

If you accessed the BFX View from the main Batch timeline, a copy appears only in the schematic.

Soft effects are not copied with the source.

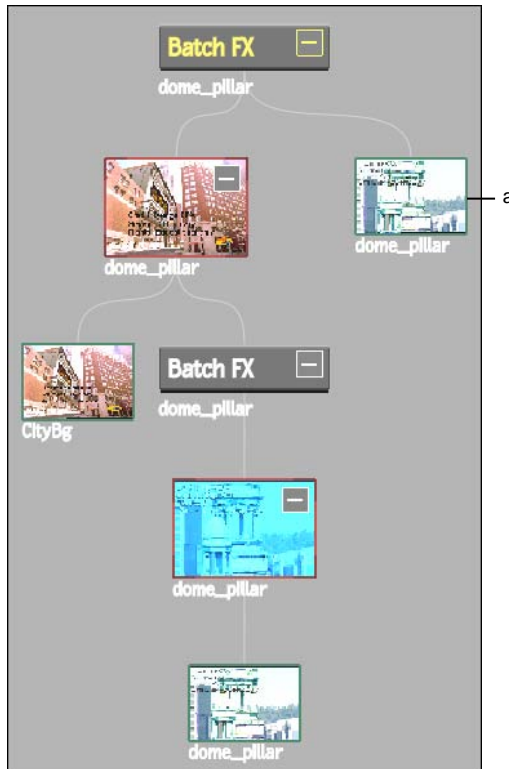

(a) Matched source clip in BFX View

Expanding Batch FX

Expand Batch FX to bring setups nested in a clip to the current level. Having setups at the same level allows for quick access to any setup. You no longer have to keep track of multiple nested setups.

You do not have to render Batch FX to expand them. However, when you expand a Batch FX, the associated clip is transformed into a setup. You can no longer perform editing functions such as trimming on the clip.

You can bring all setups nested in a clip to the current level or only the first setup nested in the clip.

You can expand the Batch setups of only one segment at a time. If a clip contains multiple segments, you must extract the segment to the schematic before expanding it.

The timing of the original timeline is preserved when you expand a setup. The frame numbering matches that of Batch.

If segments have soft effects, they are converted to the corresponding nodes when you expand the setups.

NOTE Segments with timewarps cannot be expanded.

If you expand a Batch setup containing nodes that change the duration of a clip, for example, Interlace, Deal, and Pulldown, the visual result may not be the same as before the expansion.

Expanding a Batch FX does not expand the history contained in clips within a BFX level. To expand the history of a clip brought into a BFX level, see [Modifying Clip History in Batch](#) on page 810.

To expand Batch setups:

- 1 Make sure that you are at the applicable BFX level and select the clip in the schematic.

In the following example, the selected clip is in BFX 2.

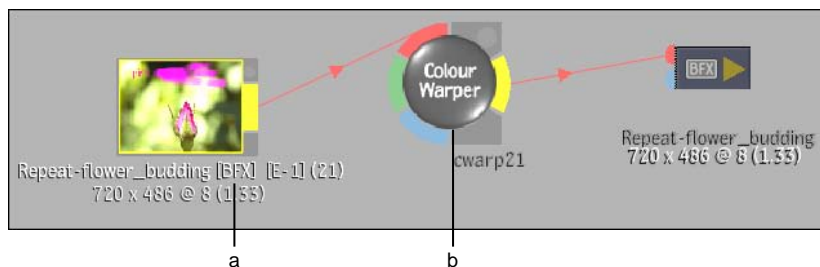

(a) Uppercase BFX indicates single segment (b) Colour Warper node in BFX 2

NOTE If the icon is lowercase bfx, the clip has more than one segment. Extract the segment to the schematic and then select it.

- 2 In the Basic menu, click Expand One to bring the setups that are one level down to the current level. Click Expand All to bring all nested setups to the current level.

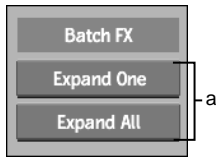

(a) Expand buttons

In the following example, Expand All was used. All setups nested inside the clip are added to the current setup. Setups from BFX 1 remain in BFX level 1.

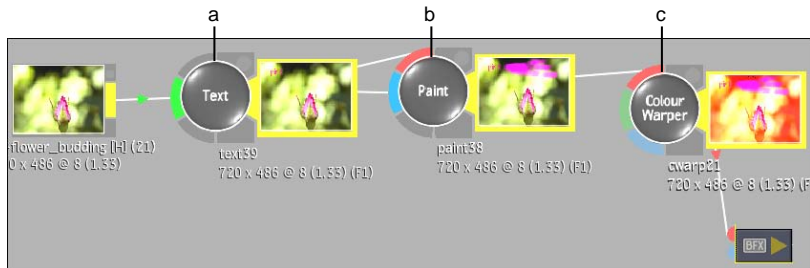

(a) Text setup from BFX 4 (b) Paint setup from BFX 3 (c) Colour Warper setup from current BFX 2

- 3 Access any node to modify the setups. If you add another Batch FX to the clip, you enter a new Batch setup (BFX 3).

Copying Batch FX

If you want to reuse a Batch FX, you can copy it as follows:

- From the timeline to the Batch schematic for use in the current setup
- From one segment to another for use in the same timeline

You can copy Batch FX as long as they were created with the Pre option. When you copy Batch FX, the Batch process tree is copied to the destination. Only the selected Batch FX is copied; nested setups are not copied.

You can also copy a node, branch, or process tree in the current setup. See [Copying Nodes](#) on page 1301.

You cannot copy Batch FX created with the Post option.

To copy a Batch FX to another segment:

- 1 Display the timeline of the segment with the Batch FX that you want to copy.
- 2 Resize the video track and **Ctrl**-drag the BFX icon to the appropriate segment.
The Batch FX is copied to the segment.
- 3 Double-click the segment to enter the setup of the copied Batch FX.

To copy a Batch FX to the current setup:

- 1 Display the timeline of the segment with the Batch FX that you want to copy.
- 2 Resize the video track and **Ctrl**-drag the BFX icon to the schematic.
The Batch setup and the corresponding segment are copied to the schematic.

Deleting Batch FX

You can gesturally delete Batch FX created with the Pre option from the timeline. You cannot delete Batch FX created with the Post option.

You cannot mute any type of Batch FX on the timeline.

To delete a Batch FX from the timeline:

- 1 Resize the video track and **Ctrl**-drag the BFX icon from the timeline to the bottom of the screen.
The Batch FX is removed from the clip and the icon from the timeline.

Previewing Batch FX

You can preview unrendered Batch FX outside of Batch. While you scrub the Player timeline, you can trigger a Batch FX render at pen-up. Batch setups are loaded and rendered at pen-up based on a timing preference you set. This preference determines how long the software will attempt the render before displaying an “Unrendered Frame” message.

Although you can preview soft effects by rendering while you scrub, Batch FX can only be rendered at pen-up.

Memory usage is optimized as much as possible so that all necessary Batch setups can be loaded into memory for the render of the current frame.

Any frames rendered are not rendered again as long as the Batch setup is not changed.

To preview Batch FX:

- 1 Display the Preferences menu and click Timeline. In the Batch FX group, enter the number of seconds in the Interactive Max field that you want the system to attempt a render.
- 2 Bring the clip with the unrendered Batch FX into the Player timeline and select Preview FX from the Preview option box.



- 3 Scrub the timeline positioner.

The Batch setups are rendered based on the timing preference. If the setups cannot be rendered in the set time, an “Unrendered Frame” message appears.

You can abort the render at any time by clicking outside the timeline.

Part 10: Effects

Part 10 includes these chapters:

- [Processing and Formatting Commands](#) on page 1425
- [Colour Corrector](#) on page 1451
- [Colour Warper](#) on page 1483
- [Filters](#) on page 1535
- [Keyer](#) on page 1545
- [Modular Keyer](#) on page 1603
- [3D Keyer](#) on page 1661
- [Garbage Masks](#) on page 1707
- [Compositor and Optics](#) on page 1763
- [Tracking and Stabilizing](#) on page 1781
- [Distort](#) on page 1821
- [Warper](#) on page 1877
- [Text](#) on page 1909
- [Sparks](#) on page 1957

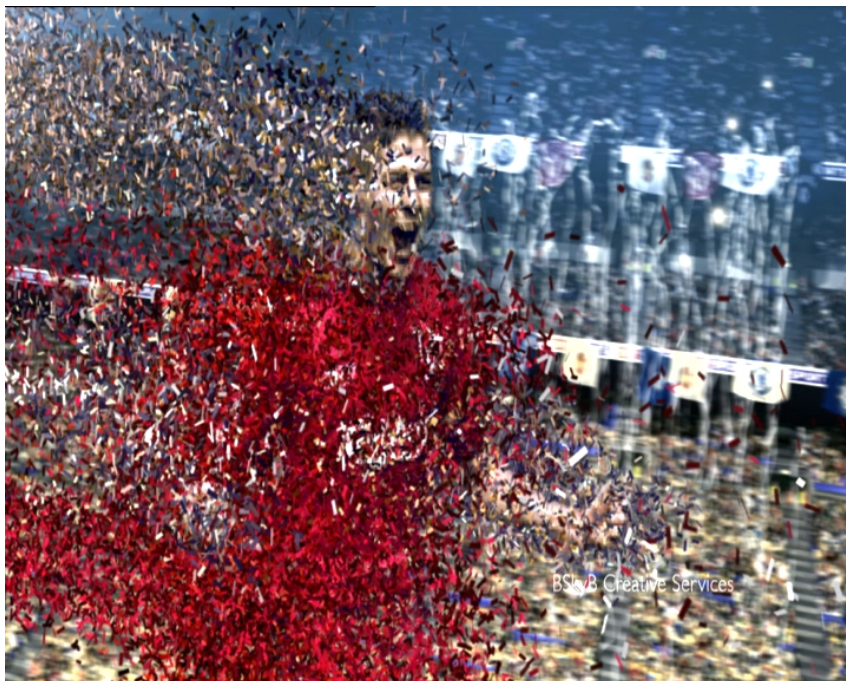

Image courtesy of B Sky B Creative Services

Processing and Formatting Commands

53

Topics in this chapter:

- [Accessing the Processing Menu](#) on page 1426
- [Simulating the Motion Blur of a Moving Object](#) on page 1428
- [Creating Compound Images](#) on page 1431
- [Flipping Images](#) on page 1432
- [Using Logical Operations](#) on page 1433
- [Generating a Difference Matte](#) on page 1437
- [Using the Auto Matte Command](#) on page 1439
- [Creating a Monochrome Clip](#) on page 1440
- [Creating a Negative Clip](#) on page 1440
- [Modifying the Luma and Chroma of a Clip](#) on page 1441
- [Creating Coloured Frames](#) on page 1442
- [Accessing the Format Menu](#) on page 1444
- [Using Separate and Combine](#) on page 1446
- [Dealing and Interleaving Clips](#) on page 1448

Accessing the Processing Menu

Use the Processing menu to apply basic commands and filters to clips. You can create visual effects, generate mattes, and enhance image quality. You can also generate coloured frames or noise.

To access the Processing menu, click the Processing button in the Main menu.

LIBRARY	Filter	Difference	Monochrome
EDITING	Average	Auto Matte	Negative
PROCESSING	Compound	Batch	Colour Correct
EFFECTS	Flip	DeGrain	Posterise
FORMAT	Logic Ops	ReGrain	Coloured Frame

The Processing commands are described as follows.

Filter Applies effects to a clip such as textures, blurring, edge detection, embossing, sharpening, or a combination of effects. You can use the filters supplied with Flame or you can create a custom filter. See [Filters](#) on page 1535.

Average Uses an image averaging function to add motion blur to a clip. See [Simulating the Motion Blur of a Moving Object](#) on page 1428.

Compound Removes noise from a static image by compressing several frames into a single frame. See [Creating Compound Images](#) on page 1431.

Flip Flips the frames in a clip horizontally, vertically, or both horizontally and vertically. See [Flipping Images](#) on page 1432.

Logic Ops Accesses the Add, Subtract, Multiply, Max/Lighten, Min/Darken, Screen, Overlay, Hard Light, Soft Light, Difference, and Exclusion modes, as well as various other Boolean operations. Use these modes to combine two source clips by applying the selected operation to their colour components. See [Using Logical Operations](#) on page 1433.

Difference Generates a matte clip from two clips that contain the same background but different foreground elements. See [Generating a Difference Matte](#) on page 1437.

Auto Matte Generates a high-contrast matte from a clip. See [Using the Auto Matte Command](#) on page 1439.

Batch Opens the Batch module, which lets you build a process tree of connected tasks. The result of one task is used as the input of the next task. You can preview the result at any point in the process tree, and modify or

delete any task without affecting the other tasks in the tree. See [Batch Processing](#) on page 1283.

DeGrain Removes grain from clips originating from film. Removing grain from a clip can make compositing processes such as keying easier to perform. See [Removing Grain from a Clip](#) on page 774.

ReGrain Restores grain to clips from which you removed grain, thereby restoring the grainy look of film. You can also add grain to video footage that you want to composite more convincingly with other grainy clips. See [Adding Grain to a Clip](#) on page 779.

Monochrome Generates a monochrome copy of a clip. See [Creating a Monochrome Clip](#) on page 1440.

Negative Generates a negative copy of a clip. See [Creating a Negative Clip](#) on page 1440.

Colour Correct Adjusts the colours in a clip. Options include:

- Adjusting the gamma, luma (brightness), contrast, hue, and saturation
- Colour balancing
- Rewiring the RGB channels
- Creating colour curves to accurately remap the colour values for different colour models of an image

See [Colour Corrector](#) on page 1451.

Posterise Produces a posterised copy of a clip by reducing the number of luma and chroma levels in the clip. See [Modifying the Luma and Chroma of a Clip](#) on page 1441.

Coloured Frame Generates clips of identical frames of a solid colour, noise, or colour bars. See [Creating Coloured Frames](#) on page 1442.

Previewing Results for Processing Commands

You can preview command results using the Desktop Module Editor. This feature allows you to perform the same functions as on the desktop, but with the added benefit of being able to preview and, in most cases, modify the effect before it is applied to the clip.

The Desktop Module Editor is available for the following Processing commands:

- Average

- Compound
- Flip
- Logic Ops
- Auto Matte
- Monochrome
- Negative
- Posterise

To apply a command using the Desktop Module Editor:

- 1 In the Processing menu, click one of the processing commands.
- 2 Select the source clips.

When the Desktop Module Editor is available for a command, an E appears on the button.



- 3 Click the E on the command button.
- 4 Select a destination.

The Editing Module appears. Use the controls in the editor as you would on the desktop.

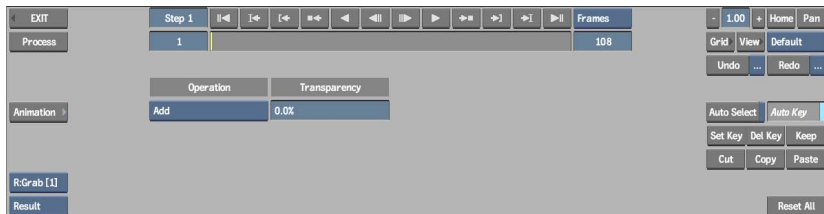

Simulating the Motion Blur of a Moving Object

Use the Average command to simulate the motion blur of a moving object in a clip. The motion blur is created by applying an image averaging function to each frame in the source clip. For each frame, partially transparent copies

of the images in the surrounding frames are superimposed on top of the image in the current frame. Since the moving object is in a different position in each successive frame, the superimposed images in one frame will also show the object in different positions, creating the blur effect.

The number of images superimposed in one frame determines the length of the blur. You can control the length as well as the transparency of the superimposed images with the Average controls, described as follows.

Average Over field Controls the number of frames used to calculate the average (the number of images superimposed on one frame). The Average Over value affects both the length and the transparency of the blur. For example, averaging over a large number of frames increases the length of the blur and the transparency of the superimposed images.

Weighted and Uniform box Controls the transparency of the blur. For each frame processed in a weighted average, the frame closest to the current frame carries the most weight in the average calculation and is the most opaque. The frame furthest from the current frame carries the least weight and is the most transparent. In a uniform average, all frames carry equal weight and are equally transparent.

Frames box You can use Past frames or both Past and Future frames to calculate the average:

- With Past Frames, only the frames that precede the current frame are considered. The motion blur follows the object.
- With Past and Future frames, the frames on both sides of the current frame are considered.

Examples of Averaging Source Clips

The following examples demonstrate using the Average command to process a source clip that is six frames long with the Average Over value set to 4. The first result clip shows a uniform average using past frames; the second result clip shows a weighted average also using past frames. The frames in the result clips are generated as follows:

- Frame 1 is the same as source frame 1. Since there are no clips preceding the first frame, the first frame in the generated clip is always the same as the first frame in the source clip.
- Frame 2 is the result of averaging source frames 1 and 2.

- Frame 3 is the result of averaging source frames 1, 2, and 3.
- Frame 4 is the result of averaging source frames 1, 2, 3, and 4.
- Frame 5 is the result of averaging source frames 2, 3, 4, and 5.
- Frame 6 is the result of averaging source frames 3, 4, 5, and 6.

Action: Select the source clip

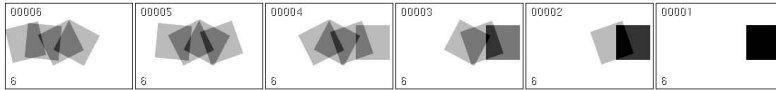

Result: Uniform average over 4 frames



Result: Weighted average over 4 frames

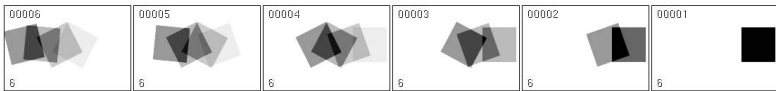

To simulate the motion blur of a moving object:

- 1 Click Average in the Processing menu.
The Average menu appears.

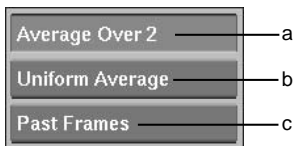

(a) Average Over field (b) Weighted and Uniform box (c) Frames box

- 2 Enter the number of frames for the average in the Average Over field.
Averaging over a large number of frames increases the length of the blur as well as the transparency of the superimposed images.
- 3 Select an option from the Weighted and Uniform box to use in the calculation. Select Weighted Average to give more weight to frames that are closer to the current frame. Select Uniform Average to give equal weight to all frames used in the calculation.

- 4 Select an option from the Frames box. Select Past Frames to use only preceding frames. Select Past and Future Frames to use frames from both sides of the current frame.
- 5 Select the source clip.
- 6 Select the destination reel.
The motion blur is processed and the result clip appears on the destination reel.

Creating Compound Images

The Compound command combines several frames in the source clip into a single frame. This is useful for removing noise from a clip of a static image. You can use the Compound command to combine all frames in the clip into a single frame for a clean image.

The Compound Over value determines the number of frames to combine into one frame. This value also determines the percentage of each source frame used to produce the new frame.

For example, if the Compound Over value is set to 2, 50% of each of the first two frames of the source clip is combined to generate the first frame of the destination clip. The third and fourth frames of the source clip are combined to generate the second frame of the destination clip, and so on. Compounding a clip over two frames generates a destination clip half the length of the source clip. To compress 20 frames into one, set the Compound Over value to 20.

To create a compound image:

- 1 Click Compound in the Processing menu.
The Compound Over field appears.
- 2 Set the value in the Compound Over field.



- 3 Select the source clip.
- 4 Select the destination reel.
The result clip appears on the destination reel.

Flipping Images

You can generate a mirror image of a clip with the Flip command. The clip can be flipped horizontally, vertically, or both, as shown.

Action: Select the source clip



Result: Flipping the clip horizontally

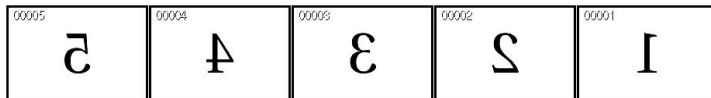

Result: Flipping the clip vertically



Result: Flipping the clip horizontally and vertically

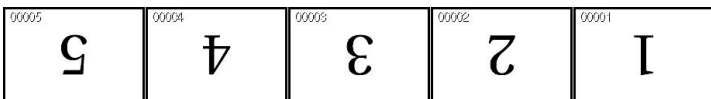

To flip clips:

- 1 Click Flip in the Processing menu.
The Flip Mode box appears.
- 2 Select an option from the Flip Mode box.

Monochrome	Delete	Horizontal
Negative	Name	Rev Dominance
Colour Correct	Move	
Posterise	Copy	
Coloured Frame	Go To	

Select:	To:
Horizontal	Flip each frame in the clip about the horizontal axis.
Vertical	Flip each frame in the clip about the vertical axis.
H & V	Flip each frame in the clip about both axes.

- 3 Select the source clip.
- 4 Select the destination reel.
The result clip appears on the destination reel.

Using Logical Operations

Logical operations are applied separately to each of the red, green, and blue components of images. You can apply Logic Ops commands to combine the RGB channels of corresponding pixels from two source images, described as follows.

Add Adds the luma values of the corresponding pixels from two source clips and assigns the resulting value to the corresponding pixel in the generated clip. If the result is greater than 255 (in 8-bit mode), the pixel in the destination clip is clamped at a value of 255 (white). In 12-bit mode, the maximum colour value is 4095.

The order in which the two source clips are selected does not affect the result of the Add operation. The generated clip is brighter than either of the two selected source clips.

And Applies a bitwise logical AND operation between the RGB channels of corresponding pixels in the two source clips. The order in which the two source clips are selected does not affect the result of the AND operation.

AndInv Applies a bitwise logical AND operation between the negative of the RGB channels of the pixels of the front clip and the RGB channels of the pixels of the back clip.

AndRev Applies a bitwise logical AND operation between the negative of the RGB channels of the pixels of the back clip and the RGB channels of the pixels of the front clip. AndRev and AndInv yield the same result if you switch the order of the two source clips.

Difference Calculates the difference between the RGB channels of the corresponding pixels of the two source clips. As opposed to Subtract, the order of the two source clips does not matter, as the smaller channel value is always subtracted from the larger channel value.

Blending with white inverts the colour channel values; blending with black produces no change.

Exclusion Adds the RGB channel values of the corresponding pixels from the two source clips, then subtracts twice the product of these channels. The order of the source clips does not matter.

HardLight Multiplies or screens the selected colour of the front clip onto the back clip, depending on the blend colour. The effect is similar to shining a harsh spotlight on the image, and greatly reduces the contrast levels in the image.

If the blend colour (light source) is lighter than 50% grey, the image is lightened as if it were screened—this is useful for adding highlights to an image. If the blend colour is darker than 50% grey, the image is darkened, as if it were multiplied—this is useful for adding shadows.

Max/Lighten Compares the RGB channels of each pixel of the source clips individually and returns the larger of the two values. The order in which you select the source clips does not affect the result.

Min/Darken Compares the RGB channels of each pixel of the source clips individually and returns the smaller of the two values in the resulting clip. The order in which you select the source clips does not affect the result.

Multiply Multiplies the RGB channel values of corresponding pixels of the two source clips and normalizes the result by dividing by 255 in 8-bit mode, or 4095 in 12-bit mode. The resulting RGB channel values are assigned to the corresponding pixels in the generated clip.

The order in which you select the source clips does not affect the result.

Nand Applies a bitwise logical AND operation between the RGB channel values of the corresponding pixels of the two source clips, negates the result,

and assigns the result to the channels of the corresponding pixels in the generated clip.

Nor Applies a bitwise logical OR operation between the RGB channel values of the corresponding pixels of the two source clips, negates the result, and assigns the result to the channels of the corresponding pixels in the generated clip.

The order in which you select the source clips does not affect the result.

Or Applies a bitwise logical OR operation between the RGB channel values of the corresponding pixels of the two source clips, and assigns the result to the channels of the corresponding pixel in the generated clip.

The order in which you select the source clips does not affect the result.

OrInv Applies a bitwise logical OR operation between the negative of the RGB channel values of the pixels in the front clip and the RGB channel values of the corresponding pixels in the back clip, and assigns the result to the channels of the corresponding pixels in the generated clip.

OrRev Applies a bitwise logical OR operation between the RGB channel values of the pixels in the front clip and the negative of the RGB channel values of the corresponding pixel in the back clip, and assigns the result to the channels of the corresponding pixels in the generated clip.

OrRev and OrInv yield the same result if you switch the order of the two source clips.

Overlay Multiplies or screens the colours, depending on the RGB channel values of the first clip you select. Patterns or colours overlay the existing RGB channel values while preserving the highlights and shadows of the first clip's colour. The first clip's colour is not replaced but is mixed with the second clip's colour to reflect the lightness or darkness of the original colour.

Screen Multiplies the inverse of the second clip's colours with the colours of the first clip. The resulting colour is always lighter. The colour remains unchanged when you screen with black. Screening with white produces white. The effect is similar to projecting multiple photographic slides on top of each other.

SoftLight Shines a soft, diffuse light on the image. If the blend colour (light source) is lighter than 50% grey, the image is lightened. If the blend colour is darker than 50% grey, the image is darkened.

Using this mode with a black frame results in a very dark effect, with white a very bright one.

Subtract Subtracts the RGB channel values of the pixels from the back clip from the RGB channel values of the pixels from the front clip and assigns the result to the RGB channel values of the pixel in the generated clip. If an RGB channel value from the back clip is larger than the corresponding channel value in the front clip, yielding a negative result, that result is clamped at 0 (black).

The order of the source clips is important since the back clip is subtracted from the front clip. The resulting clip is always darker than either of the two source clips.

Xnor Applies a bitwise logical exclusive OR operation between the RGB channel values of the corresponding pixels of the two source clips, negates the result, and assigns the result to the channels of the corresponding pixels in the generated clip.

The order in which you select the source clips does not affect the result.

Xor Applies a bitwise logical exclusive OR operation between the RGB channel values of the corresponding pixels of the two source clips, and assigns the result to the channels of the corresponding pixels in the generated clip.

The order in which you select the source clips does not affect the result.

To use logical operations:

- 1 In the Processing menu, click Logic Ops.
The Logical Operations box appears.

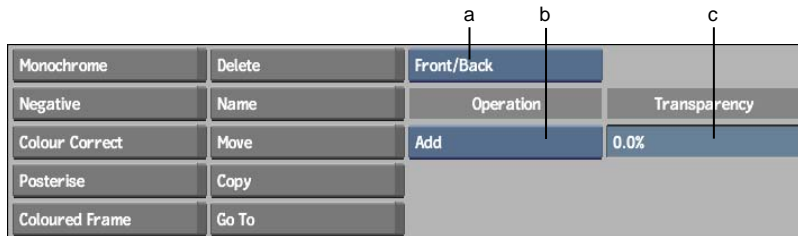

(a) Layer Selection box (b) Logical Operations box (c) Transparency field

- 2 Select the mode you want to use from the Logical Operations box.
- 3 Select an option from the Layer Selection box. You can select either a Front and a Back clip, or a Front, Back, and Matte clip.
- 4 Specify the transparency value.

Use the default value of 0.0% to combine your clips completely. Using any value above zero results in an effect in which the specified layers are combined, but you can see through the combined clips to the original Back clip.

- 5 Select the source clips to be used for the operation. The order in which clips are selected affects the outcome of some operations.

NOTE If you want to use clips of different resolutions, resize them according to the common destination resolution. See [Resize](#) on page 663.

- 6 Select the destination reel.
The generated clip appears on the destination reel.

Generating a Difference Matte

Use the Difference command to generate a matte clip from two source clips with the same background but different foreground elements. This allows you to remove an image from one context to add it to another.

When you generate a difference matte, the difference between corresponding pixels of the two source images is calculated. The value of the pixel in the back image is subtracted from the value of the corresponding pixel in the front image, and the resulting absolute value is used in the difference matte.

The matte is created using Tolerance and Softness values. The Tolerance value specifies the difference level that is considered black. A high Tolerance value includes more black in the matte. The Softness value is used to soften the transition between the light areas and the dark areas of the matte by adjusting the amount of grey at its edges. Grey information is not included in the matte when the Softness is zero. Use a high Softness value to increase the grey.

To generate a difference matte:

- 1 Click Difference in the Processing menu.
- 2 Select the Front and Back source clips (in that order).

NOTE If you want to use clips of different resolution, resize them according to the common destination resolution. See [Resize](#) on page 663.

- 3 Select the destination reel.
The Difference menu appears.



(a) Colour channels

- 4 Select Result from the View box or press **F4** to display the resulting matte clip.
- 5 Select the colour model to use for the difference matte: RGB or YUV.
- 6 Choose one or more colour channels to use for the difference matte. You can use any of the Y, U, or V channels in the YUV colour model, or any of the R, G, or B channels in the RGB colour model.
- 7 Set the tolerance for the matte by pressing on the colour pot beside the Tolerance field in the same row as the colour channel you are using. Drag the colour picker around the area of the image to create the matte.

NOTE You can also set the tolerance for the matte directly in the Tolerance field.

- 8 Set the softness for the matte using either the Softness field or the colour pot beside the field.
- 9 Use the Gain and Lift fields to manipulate the resulting matte.

Use:	To:
Gain	Boost the matte. Difference multiplies the values of the pixels in the result matte by the Gain.
Lift	Add the Lift value to all pixels in the difference matte.

- 10 Click Process.

Using the Auto Matte Command

The Auto Matte command generates a high-contrast matte from a clip. The controls are described as follows.

Minimum Specifies the minimum colour value for the matte. Any pixel with a luma value below the minimum value is set to black. The minimum can be set to any value between 0 and 255 in 8-bit mode, or between 0 and 4095 in 12-bit mode.

Maximum Specifies the maximum colour value for the matte. Any pixel with a luma value above the maximum is set to white. The maximum can be set to any value between 0 and 255 in 8-bit mode, or between 0 and 4095 in 12-bit mode.

Gain Boosts the matte. Any pixel with a luma value between the minimum and maximum values is multiplied by the Gain and the new value is assigned to the resulting pixel. Using a low value for the Gain produces a soft matte with more grey levels. Using a high value produces a matte with fewer grey levels. Gain is expressed as a percentage value. The default value of 100% has no effect on the image since luma values are multiplied by 1.

To use the Auto Matte command:

- 1 Click Auto Matte in the Processing menu.

The Auto Matte menu appears.

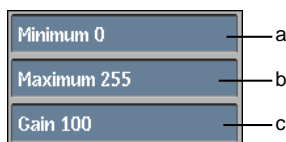

(a) Min field (b) Max field (c) Gain field

- 2 Set the values in the Minimum, Maximum, and Gain fields.
- 3 Select the source clip.
- 4 Select the destination reel.

A matte clip appears on the destination reel.



Original image

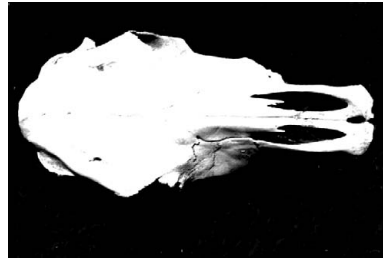

Matte generated with Min = 82, Max = 157

Creating a Monochrome Clip

The Monochrome command quickly generates a clip using monochrome colours. You can also adjust the clip's luminance..

To create a monochrome clip:

- 1 Click Monochrome in the Processing menu.
- 2 Select a channel from the Luminance box.

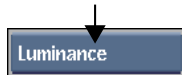

- 3 Select the source clip.
- 4 Select the destination reel.

The monochrome clip appears on the destination reel.

Creating a Negative Clip

The Negative command quickly generates the negative of a source clip. The colour values of each pixel in the source image are inverted to produce the negative image.

To create a negative clip:

- 1 Click Negative in the Processing menu.
- 2 Select the source clip.
- 3 Select the destination reel.

A negative copy of the clip appears on the destination reel.

Modifying the Luma and Chroma of a Clip

You can specify the number of luma and chroma levels in a source clip with the Posterise command. Each frame in the clip is divided into an equal number of luma and chroma levels, and each pixel of the image is mapped to the closest matching level.

To modify the luma and chroma of a clip:

- 1 Click Posterise in the Processing menu.

The Posterise menu appears.



(a) Posterise box (b) Levels field

- 2 Select the channel(s) to use from the Posterise box.

Select:	To:
Chroma	Reduce the number of chroma levels, or units, in a clip. Chroma levels affect the red, green, and blue channels individually. For example, setting the chroma level to 2 creates 2 levels of red, blue, and green.
Luma	Reduce the number of luma levels, or units, in a clip.

Select:	To:
Luma & Chroma	Reduce the number of luma and chroma levels, or units, in a clip.

- 3 In the Levels field, specify the number of levels you want to use to comprise the selected channel. Increasing the number decreases the posterizing effect. Decreasing the number increases the effect.
- 4 Select the source clip.
- 5 Select the destination reel.
The posterised clip appears on the destination reel.



Original image



Posterised image, Levels = 5

Creating Coloured Frames

Use the Coloured Frame command to generate a clip with one or more identical frames of a solid colour, noise, or SMPTE or PAL colour bars.

To create coloured frames:

- 1 Click Coloured Frame in the Processing menu.
The Coloured Frame menu appears.

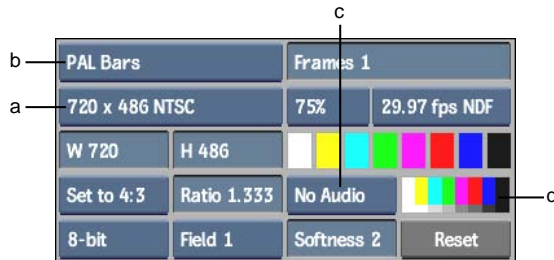

(a) Frame Number field (b) Frame Mode box (c) Current audio tone (d) Current Colour pot

2 Select the type of frame to generate from the Frame Mode box.

Select:	To generate frames of:
Colour	A solid colour.
Noise	Video static noise.
Colour Noise	Colour video static noise.
SMPTE Bars	SMPTE standard colour bars.
PAL Bars	PAL standard colour bars.

3 Specify the number of frames that you want to generate in the Frame number field.

4 If the Frame Mode is set to Colour, set the colour to be used for the frames in the Current Colour pot. Perform one of the following:

- Click one of the colour pots that appears below the Current Colour pot to transfer that colour into the Current Colour pot.
- Click the Current Colour pot to display the colour picker. Use the colour picker to create the current colour as described in [Picking Colours](#) on page 71.

5 If the Frame Mode is set to Colour, PAL Bars, or SMPTE Bars, you can also generate specific audio tones or silence with the frames.

Select:	To generate:
10 kHz Tone	A colour source with a 10 kHz tone.

Select:	To generate:
1 kHz Tone	A colour source with a 1 kHz tone.
400 Hz Tone	A colour source with a 400 Hz tone.
60 Hz Tone	A colour source with a 60 Hz tone.
Silence	A colour source with empty audio tracks.
No Audio	A colour source without audio.

- 6 You can specify up to eight audio tracks for the frame.
If the Frame Mode is set to PAL Bars or SMPTE Bars, set the following options:

- In the Luminance box, select 75% or 100% to set the luminance of the colour bars.

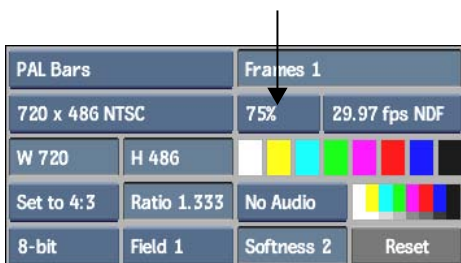

- In the Softness field, enter a value (0-10) to set the softness between colour bars.
- 7 Choose a resolution, width, height, pixel aspect ratio, frame depth, and scan mode for the clip. See [Resize Settings](#) on page 681.
- 8 Select the destination reel.
The generated clip appears on the destination reel.

Accessing the Format Menu

Use the Format menu to format source material or solve image quality problems. To display the Format menu, click Format in the Main menu.

LIBRARY	Deinterlace	Remove Pulldown	Separate
EDITING	Interlace	Add Pulldown	Combine
PROCESSING	Field Merge	Burn In	Interleave
EFFECTS	Dominance	Change TC / KC / Rate	Deal
FORMAT	Extract Proxies	Regenerate Proxies	Resize LUT

The Format commands are described as follows.

Deinterlace Separates the odd and even scanlines of a video clip. For each frame of the source clip, the result clip contains: one frame with the odd scanlines (field 1) and one with the even scanlines (field 2). See [Deinterlacing Clips](#) on page 726.

Interlace Interlaces the odd and even scanlines of a video clip. For each pair of frames in the source clip, the odd scanlines of one frame are interlaced with the even scanlines of the second frame to produce a single frame in the generated clip. See [Interlacing Clips](#) on page 727.

Field Merge Merges the fields of a clip to remove field jitter. See [Merging Fields](#) on page 727.

Dominance Changes the current field dominance of a selected clip. See [Managing Field Dominance](#) on page 720.

Extract Proxies Extracts proxies from the selected clip. See [Extracting Proxies](#) on page 544.

Film Compress Removes field artifacts introduced in a 24-to-30-fps conversion process. See [Removing and Inserting Pulldown on the Desktop](#) on page 712.

Film Expand Produces the appropriate field sequence for converting a clip from 24 to 30 fps. See [Removing and Inserting Pulldown on the Desktop](#) on page 712.

Burn In Stamps a timecode or frame numbers on a clip. See [Burning-in Clip Information](#) on page 428.

Change TC / KC / Rate Changes the timecode, keycode, or rate of a clip. See [Changing Timecode](#) on page 418.

Regenerate Proxies Regenerates proxies for selected clips. See [Regenerating Proxies](#) on page 543.

Separate Separates the individual red, green, and blue channels of an image. See [Using Separate and Combine](#) on page 1446.

Combine Combines the red channel from one clip, the green channel from another clip, and the blue channel from a third clip to produce a single clip. See [Using Separate and Combine](#) on page 1446.

Interleave Interleaves the frames of two clips to produce a single clip. See [Dealing and Interleaving Clips](#) on page 1448.

Deal Divides the number of frames in a source clip equally into a number of smaller clips. See [Dealing and Interleaving Clips](#) on page 1448.

Resize Changes the resolution of a clip and its frame bit depth. See [Resize](#) on page 663.

Previewing Results for Format Commands

You can preview Format command results by using the Desktop Module Editor. This feature is available for the following Format commands:

- Deinterlace
- Interlace
- Field Merge
- Film Compress
- Film Expand
- Deal
- Combine

The instructions for using the Desktop Module Editor are the same as for Processing commands. See [Previewing Results for Processing Commands](#) on page 1427.

Using Separate and Combine

You can use the Separate and Combine commands in the Format menu to reconfigure colour channels in clips. Use the Separate command to create monochrome clips from the red, green, and blue channels of a clip. Use the Combine command to merge the red, green, and blue channels from three clips into one.

Combining RGB Channels in a Clip

Use the Combine command to combine individual channels of three different source clips. To generate the new clip, the Combine command uses:

- The red channel information of the first source clip selected
- The green channel information of the second source clip selected
- The blue channel information of the third source clip selected

To combine RGB channels:

- 1 In the Main menu, click Format.
- 2 In the Format menu, click Combine.
- 3 Select the first source clip. The red channel information of this clip will be used in the generated clip.
- 4 Select the second source clip. The green channel information of this clip will be used in the generated clip.
- 5 Select the third source clip. The blue channel information of this clip will be used in the generated clip.
- 6 Select a destination reel.
The generated clip appears on the destination reel.

Separating RGB Channels in a Clip

Use the Separate command to separate the red, green, and blue channels of a clip. A monochrome clip containing the information from the selected colour channel only appears. For example, to generate a clip containing the red channel information of a source clip, select Red.

To separate colour channels:

- 1 In the Main menu, click Format.
- 2 In the Format menu, click Separate.
The Channel box appears.
- 3 Select the channel you want to separate from the Channel box.



Select:	To generate:
Red	A monochrome clip containing only red channel information.
Green	A monochrome clip containing only green channel information.
Blue	A monochrome clip containing only blue channel information.
All	Three monochrome clips: one for each channel.

- 4 Select the source clip.
- 5 Select the destination reel.
- 6 The clip(s) are generated and appear on the destination reel.

Dealing and Interleaving Clips

Use Deal and Interlace to deal out the frames of a single clip evenly to any number of destination clips, or to shuffle the frames of two clips into a single clip, with a regular spacing interval.

Dealing Clips

Deal is a one-to-many process by which frames are dealt like cards to any number of “hands”. Each hand is a separate clip. For example, a 9-frame clip dealt to 3 separate clips results in:

- One result clip made from frames 1, 4, and 7
- One result clip made from frames 2, 5, and 8
- One result clip made from frames 3, 6, and 9

To deal clips:

- 1 In the Format menu, click Deal.
The Clips field appears.
- 2 Enter a value in the Clips field to set the number of clips into which the frames of the source clip are dealt.



- 3 Select the clip that you want to deal.
- 4 Select a destination reel.
After a short time, the dealt clips appear.

Interleaving Clips

Interleave is a two-to-one process that shuffles the frames of one clip into another with a regular spacing interval. For example:

- Setting the spacing interval to 1 creates a clip that alternates frames from the first source clip and the second source clip.
- Setting the spacing interval to 3 interleaves each frame of the first source clip after every third frame of the second source clip.

In both cases, the first frame of the new clip is the first frame of the first, or shuffled, source clip.

To interleave clips:

- 1 In the Format menu, click Interleave.
The Spacing field appears.
- 2 Enter a value in the Spacing field.

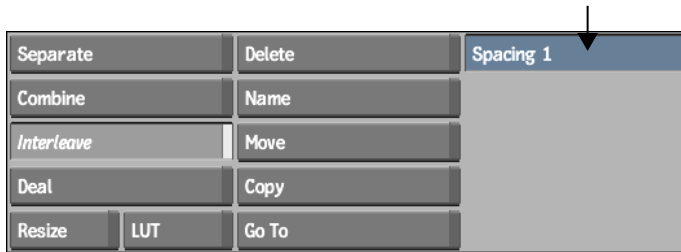

- 3 Select the first source clip.
- 4 Select the second source clip.

NOTE The clips must be of the same resolution.

- 5 Select the destination reel.
After a short time, the result clip appears.

Topics in this chapter:

- [About Colour Correcting](#) on page 1451
- [Accessing the Colour Corrector](#) on page 1452
- [Viewing Clips](#) on page 1455
- [Changing Colour Corrector Settings](#) on page 1457
- [Colour Sampling](#) on page 1462
- [Matching Colours](#) on page 1465
- [Colour Correcting from the Main Menu](#) on page 1467
- [Adjusting the Colour Range](#) on page 1475
- [Remapping Colour Values](#) on page 1479
- [Animating a Colour Correction](#) on page 1480
- [Processing Colour Changes](#) on page 1481

About Colour Correcting

The Colour Corrector includes tools that provide precise control over colour values. You can modify luma ranges in a clip (shadows, midtones, and highlights), sample colours, and adjust the colour balance. You can rewire colour channels and suppress colours, as well as animate a colour correction by manipulating the animation curve in the Channel Editor.

When working with the Colour Corrector, you can customize the colour correction environment.

You can enter the Colour Corrector from some other Flame modules such as Action and the Keyer. The Colour Corrector is particularly useful for removing colour spills in the Keyer. If you enter the Colour Corrector from a module, you are returned to that module when you exit the Colour Corrector.

You can also access the Colour Warper from the Colour Corrector. The Colour Warper works in parallel with the Colour Corrector—you can colour correct clips with the Colour Corrector and Colour Warper and then compare the results. Each setup is saved separately. For more information, see [Colour Warper](#) on page 1483.

Accessing the Colour Corrector

To access the Colour Corrector, you must load clips of the same resolution. If the clips you want to load have different resolutions, resize them so that they have the same resolution.

You can load a front clip, a front and back clip, or a front, back, and matte clip for colour correction. Changes in colour are applied to the front clip.

The Colour Corrector can be accessed from the following locations:

- The Processing menu.
- Other modules, including Action, the Keyer, and Paint. See [Accessing the Colour Corrector from Other Modules](#) on page 1453.

To access the Colour Corrector:

- 1 In the Main menu, click Processing.
- 2 In the Processing menu, click Colour Correct.



(a) Colour Correct button (b) Input Mode box

- 3 Select an option from the Input Mode box.

Select:	To:
Front	Colour correct a single clip.
Front/Back	Match and colour correct the colours of the front clip using the back clip as a reference. Only the front clip is processed.
Front/Back/Matte	Colour correct the region of the front clip defined by the opaque area of the matte. The front, back, and matte clips are composited together when processed.

- 4 Select the source clips. The source clips must have the same resolution.

NOTE If you want to use clips of different resolution, resize them according to the common destination resolution. See [Resize](#) on page 663.

- 5 Select the destination for the processed clip.
The Colour Corrector menu appears.

TIP Click the Colour box to display the Colour Warper menu. See [Colour Warper](#) on page 1483.

Accessing the Colour Corrector from Other Modules

You can colour correct clips loaded into Action, Paint, , the Compositor, or the Keyer. You can also use the Colour Corrector in Batch and the Modular Keyer.

NOTE Back clips and key-in clips cannot be colour corrected.

To access the Colour Corrector from Paint:

- 1 Do one of the following:
 - To colour correct a clip, click Setup in the Paint menu, enable CC, and then enable the CC button for the clip you want to colour correct. The clip is loaded into the Colour Corrector.
 - To colour correct a cutout, click Cut/Paste in the Paint menu, create a cutout, and then use the Colour Correction field or click CC. The cutout is loaded into the Colour Corrector.

- 2 To return to the Paint menu, click Return or Cancel, and then click Confirm.

To access the Colour Corrector from Action:

- 1 From the Media menu, select the media containing the clip you want to colour correct.
- 2 Double-click the CC field for the media you want to colour correct. The clip is loaded into the Colour Corrector.
- 3 To return to Action, click Return.

To access the Colour Corrector from the Keyer:

- 1 Click CCF.
The front clip is loaded into the Colour Corrector. Only the front clip can be colour corrected when you access the Colour Corrector from the Keyer. Use the Colour Corrector to improve the look of the key and remove colour spill. See [Keyer](#) on page 1545.
- 2 To return to the Keyer, click Return or Cancel.

To access the Colour Corrector from the Compositor:

- 1 Click the CC button for the clip that you want to colour correct. The selected clip is loaded into the Colour Corrector. Use the Colour Corrector to colour correct the front, back, and matte clips. See [Compositor and Optics](#) on page 1763.
- 2 To return to the Compositor, click Return.

To access the Colour Corrector from Batch or the Modular Keyer:

- 1 In the Batch or Modular Keyer menu, click Schematic or tap the left swipe bar to display the node bars.
- 2 Drag the Colour Corrector node from the node bar and place it in the schematic. Make sure you connect to other nodes or clips in the process tree.
- 3 Click the Colour Corrector node. If necessary, disable Setup. The Colour Corrector menu appears.

Hiding the Colour Corrector Menu

You can hide the Colour Corrector menu while adjusting an image if you find the menu distracting. With the menu hidden you can modify numeric fields, use the colour wheel, or access buttons via their corresponding hot keys.

To hide the Colour Corrector menu while modifying a numeric field or the colour wheel:

- 1 Click and hold any numeric field or the colour wheel. For example, click and hold the Hue field.
- 2 Press **Alt+'** (on the Tilde key) while continuing to hold the cursor. The Colour Corrector menu is hidden.
- 3 Drag the cursor to modify the field value or adjust the colour wheel. The changes you apply will be visible in the image as you drag if Regen is enabled (see [Dynamic Updating](#) on page 1457). Otherwise, the changes appear when you release the mouse.
- 4 Press **Alt+'** (on the Tilde key) to display the menu.

To hide the Colour Corrector menu while accessing buttons via their corresponding hot keys:

- 1 Press **Alt+'** (on the Tilde key).
- 2 Use the Colour Corrector hot keys.
- 3 Press **Alt+'** (on the Tilde key) to display the menu.

Viewing Clips

You can view a front, back, matte, or result clip in the image window. The front, back, and matte clips show the source clips used. The result clip shows your colour corrections as you apply them.

You can also view the following information for the clip:

- Channel: displays the numerical data used by the components in the clip.
- Reference: displays any referenced clips.
- Tracks: displays when an effect is used in the timeline

- Info: lists the channel, components, any related values, and the number of keys used in each effect in the clip.

To display a clip:

- 1 From the View box, select the clip you want to view. For example, select Result to view the result clip.

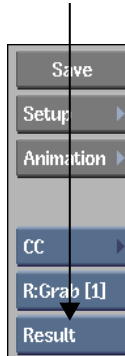

TIP Use the controls below the image window to change the frame displayed in the image window. Use the viewing tools in the upper-right corner of the panel to enlarge and pan images.

To change the clip that is displayed using the hot keys:

- 1 Consult the following table.

To display:	Press:
The front clip	F1
The back clip	F2
The matte clip	F3
The result clip	F4
The channel data	F5
The track timeline	F5
The Info table	F5

To display:	Press:
The Referenced clips	Select Reference from the View box

Changing Colour Corrector Settings

In the Colour Corrector Setup menu, you can change matte clip settings, the way that colour changes are updated, background brightness, and cropping. You can also reset colour corrections made from the Colour Corrector, Colour Warper, or both.

To access the Colour Corrector Setup menu:

- 1 Click Setup in the Colour Corrector menu.

Inverting the Matte

You can invert the matte clip. Inverting the matte swaps the transparent and opaque areas of the matte and redefines the area of the front image that can be colour corrected, as well as the area of the back image that is shown.

To invert the matte clip:

- 1 Enable Invert Matte in the Setup menu.

Dynamic Updating

Use the Regen button to enable dynamic updating of changes you make in the Colour Corrector. When Regen is enabled, you see the changes interactively as you adjust the values in the various displays. When Regen is disabled, you do not see changes until values are entered after releasing the cursor, or by clicking the **Enter** key in the calculator.

To enable dynamic updating:

- 1 Enable Regen.

NOTE The Regen button is accessible from all Colour Corrector menus.

Changing the Background Brightness

You can adjust the brightness of your work area background. Changing the background brightness is a global setting. Changing the brightness through the Colour Corrector menu has the same effect as changing it through the Preferences menu.

To change the background brightness:

- 1 Enter a value in the Background field of the Colour Corrector Setup menu.

TIP To increase the background colour's brightness, enter a high number.

Creating a Crop Box

Use a crop box to view the colour changes to a limited region of the front clip. Colour changes only appear in the area within the crop box. This feature speeds up processing and lets you see the difference between the source clip and the result clip.

For example, while colour correcting, you can use the crop box to split the image window. The split window allows you to view the front clip and the result or matte clip at the same time.

To create a crop box:

- 1 Do one of the following:
 - Hold down the **Ctrl** key or hold the pen button and drag the box across the image.
 - Turn on the Crop button and enter the dimensions for the crop box in the Left, Right, Bottom, and Top fields.

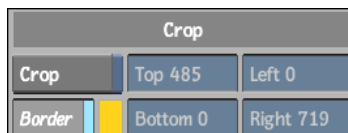

The crop box appears in the image window. The display inside and outside the crop box depends on how many clips are loaded.

If you loaded:	Inside the crop box:	Outside the crop box:
A front, back, and matte clip	Shows the front clip in the opaque area of the matte and the back clip in the transparent area of the matte.	Shows the back clip.
A front and back clip	Shows the front clip.	Shows the back clip.
A front clip only	Shows the colour-corrected clip.	Shows the non-colour corrected clip.

- 2 To adjust the size of the crop box, drag on the corner points of the box, or modify the values in the Left, Right, Bottom, and Top fields in the Setup menu.
- 3 To move the crop box in the image window, click a side of the box and drag to a new location. Alternatively, press **Ctrl** and redraw the crop box.

To disable a crop box:

- 1 From any Colour Corrector menu, disable the Crop button.
When you disable the Crop button in a Colour Corrector menu, it is also disabled in the Setup menu.

Changing the Colour of the Crop Box

You can change the colour of the crop box so that it is easier to distinguish from the rest of your image.

To change the colour of the crop box:

- 1 In the Colour Corrector Setup menu, click the colour pot beside Border.

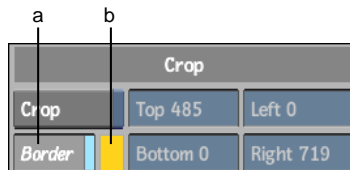

(a) Border button (b) Colour pot

The colour picker appears.

- 2 Select a colour with the colour picker.
- 3 Click in the Border colour pot to apply the new colour to the border.

Hiding the Crop Box

You can hide the crop box to prevent it from affecting your colour correction.

To hide the crop box:

- 1 In the Setup menu, disable Border.

Viewing Reference Clips

You can use the split bar to view and sample a reference clip while you work. Reference clips are particularly useful when you want to match colours or compare colour corrections.



(a) Focus clip (b) Split bar (c) Reference clip

There are several reference clips available. See [Displaying the Reference Area](#) on page 131.

Resetting Colour Corrections

You can reset colour corrections created with the Colour Corrector, the Colour Warper, or both. You can also reset the corrections you make inside the Colour

Corrector using the basics menu, or by using the Range, Histogram, or Curve graphs.

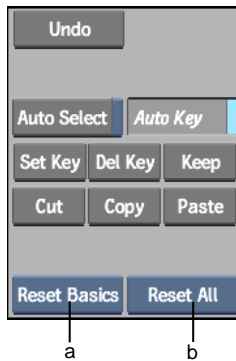

(a) Reset in Colour Corrector (b) Reset in CC, CW, or both

To reset a colour correction:

- 1 Select an option from the Reset box on the right.

Select:	To reset:
Reset All	The entire module. Both the Colour Corrector and Colour Warper settings are reset to their default values.
Reset CC	The Colour Corrector. Settings in the Colour Warper are not affected.
Reset CW	The Colour Warper. Settings in the Colour Corrector are not affected.

- 2 Click Confirm.

To reset a colour correction within the Colour Corrector:

- 1 Select an option from the Reset box on the left.

Select:	To reset:
Reset Basics	The basic properties of the Colour Corrector. Any changes made using the Curve, Histogram, or Range charts are unaffected.
Reset Curve	The settings defined by the Curve chart. The Basic properties of the Colour Corrector are unaffected.

Select:	To reset:
Reset Histo	The settings defined by the Histogram. The Basic properties of the Colour Corrector are unaffected.
Reset Range	The settings defined by the Range chart. The Basic properties of the Colour Corrector are unaffected.

Saving Colour Correction Setups and Preferences

You can save or load colour correction setups using the Save or Load button. Any setup can be loaded from the file browser for use with another set of clips. You can also save or load colour correction preferences using the Load or Save button.



- To save setups or preferences, click Save.
- To load setups or preferences, click Load.

TIP Click Revert to revert to the last saved setup. All changes made since the previous Save operation are undone.

When you save colour correction setups, you save the current settings for both the Colour Corrector and the Colour Warper to the setup file. If you overwrite a setup file using the Save button, the current settings in both the Colour Corrector and Colour Warper are saved.

For more information, see [Saving Setups and Preferences](#) on page 799.

Colour Sampling

You can sample colours from the front and back clips, and instantly see how the front clip will be affected by the colour correction.

Colours are sampled using colour patches. The sampled colours appear in the patches with their colour values. You can display the RGB, HLS, or Y (luma) values for the sampled colours. You can choose to display numerical sample data as either RGB bit values or percentages.

The colour patches appear with the Main, Histogram, Curves, and Ranges menus. They are hidden when you are using the Setup menu or Animation controls.

To sample a colour:

- 1 Below the colour patches, select the sample option you want to use.

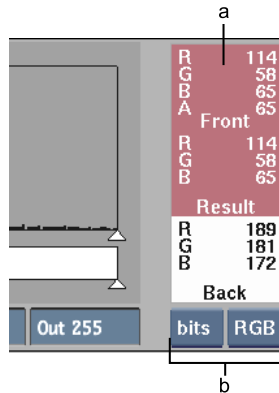

(a) Colour patches (b) Sample options

Select:	To:
Y	Display the NTSC luma values for the colours sampled. Either NTSC 601 or HD 709 luma values are displayed, depending on the settings in the configuration file. See the <i>Autodesk Visual Effects and Finishing Configuration File Reference Guide</i> .
HLS	Display the hue, lightness, and saturation values for the colours sampled.
RGB	Display the red, green, and blue values for the colours sampled.
Off	Turn off the colour information display.

- 2 Click the Front colour patch to sample a colour from the front clip. Click the Back colour patch to sample a colour from the back clip. Click both patches to sample front and back clips simultaneously.
The cursor becomes a colour picker.
- 3 To sample an individual pixel, click a colour in the image.

- 4 To sample an average colour, **Alt**-drag in the image, or press **Ctrl** and draw a selection box.

TIP Zoom in for more precise colour sampling.

The sampled colour appears in the colour patch. The sampled colour also appears in each menu.

In:	A sample is displayed:
Main menu	As a reference point on the colour wheel. A black reference point indicates the colour you sampled from the front clip. A white reference point indicates the sample from the back clip.
Histogram menu	As a red vertical line on the gradient bar, indicating the luma value. Only the front sample is displayed.
Curves menu	As red, green, and blue values mapped to the colour curves.
Ranges menu	As a red vertical line on the Luminance gradient bar, indicating the luma value. Only the front sample is displayed.

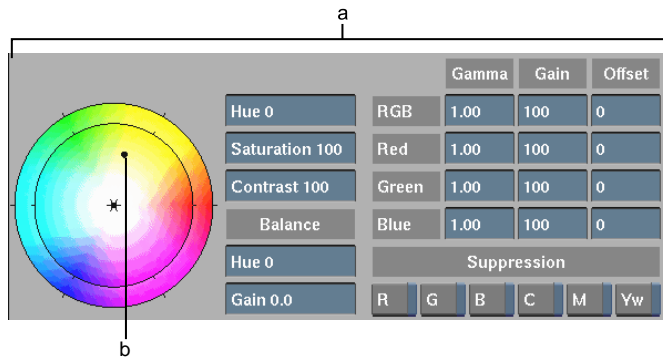

(a) Main menu (b) Colour sample

Colour Sampling and Processing Order

You can use any combination of colour correction commands to modify the front clip. The commands are processed in the following order:

- RGB Rewiring, Monochrome, Negative

- Hue Shifting
- Saturation
- Colour Balancing
- Gamma, Gain, Offset, and Contrast
- Histogram
- Colour Curves
- Chroma Suppression

The processing order is important in determining the colour that appears in the middle (result) section of the colour patch. The middle section displays the colour resulting from the application of all colour correction setups; in other words, the colour at the end of the processing order. This colour is updated as you change any parameter value. The original front colour appears in the left section of the patch.

Matching Colours

You can match and colour correct the colours of the front clip using the back clip as a reference. To perform a match operation, sample colours from the front and back clip and then use the Match button in the Curves menu.

To match colours between two clips:

- 1 Load a front and back clip from the Desktop.
- 2 Use the split bar to view the front and back clips in the image window. See [Displaying the Reference Area](#) on page 131.
- 3 Click Curves.
The Curves menu appears.

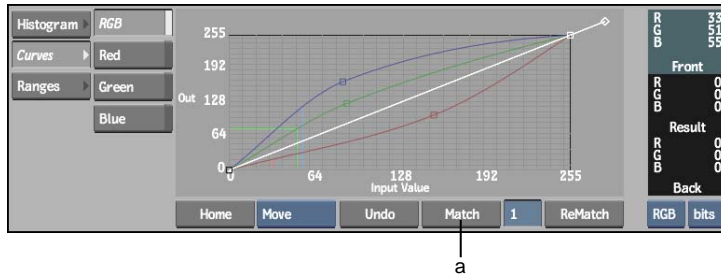

(a) Match button

- 4 Click the Front colour patch.
The colour picker appears.
- 5 Using the colour picker, select a colour in the front clip to be corrected.
The colour is added to the Front and Result colour patches.
- 6 Click the Back colour patch.
The colour picker appears.
- 7 Using the colour picker, select a colour in the back clip to use as a reference colour.
- 8 Click Match.

The reference colour is applied to the result clip. The reference colour is also added to the Result colour patch and points are added to the colour curves.

When you use Match, a number is displayed in the numerical field beside the ReMatch button. The first match you perform is indicated by a 1 in the field, the second by a 2, and so on. To revert to a previous match, click the numerical field and type the number of the match you want to recall. The colour patches and colour curves reset to the values stored in the specified match.

To reset all the colour curves, click Reset Curve. To reset the red, green, blue, or RGB curve only, select a curve and click Reset Curve. The Curves menu also has its own Undo button that is separate from the overall Colour Corrector Undo.

Colour Correcting from the Main Menu

The Main menu contains the controls used to perform colour correction. You can:

- Colour correct shadows, midtones, and highlights separately or together.
- Adjust the hue, saturation, or contrast of an image.
- Rewire the red, green, or blue channels of an image.
- Create a negative or monochrome image.
- Adjust the gamma of the individual red, green, blue, or RGB channels.
- Adjust the red, green, blue, or RGB values in an image by modifying the gain and the offset values for the channel.
- Perform colour suppression.
- Adjust the colour balance.

To reset any of these changes, click Reset Basics. To reset all the changes in the Colour Corrector, click Reset All.

Colour Correcting Shadows, Midtones, and Highlights

When you modify Saturation, Gamma, Gain, Offset, and Contrast, you can colour correct the shadows, midtones, and highlights ranges in the image individually or all together.

To colour correct shadows, midtones, or highlights:

- 1 Select the luma range you want to modify.

Click:	To modify:
Shadows	Dark areas in the image.
Midtones	Midlevel areas in the image.
Highlights	Light areas in the image.
Master	The entire image. Modification made in the Master range are applied after individual range modifications.

NOTE Monochrome, Negative, Chroma Suppression, and RGB Rewiring always affect the Master tonal range.

Adjusting the Hue

Hue is the main attribute that distinguishes one colour from another. When you adjust the hue, you also change the colours in the image.

NOTE Hue shift can be applied to individual ranges (highlights, midtones, and shadows) or to the Master tonal range.

To adjust the hue of an image:

- 1 Select the range you want to modify: Master, Shadows, Midtones, or Highlights.
- 2 Drag the Hue field to adjust the level of hue and saturation until you are satisfied with the result.

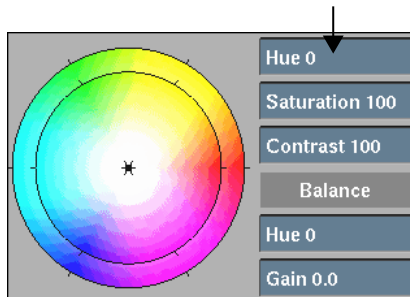

- 3 Click Process to apply the changes to the clip.

Adjusting the Saturation

You can adjust the purity of colour in an image by adjusting the saturation level. Increasing the level of saturation decreases the amount of grey and produces purer colours. Decreasing the level of saturation increases the amount of grey and reduces the purity of colours.

To adjust the saturation of an image:

- 1 Select the range you want to modify.
- 2 Drag the Saturation field to decrease or increase the level of saturation until you are satisfied with the result.
- 3 Click Process to apply the changes to the clip.

Adjusting the Contrast

Control the gradations between the light and dark areas of an image by adjusting the contrast.

To adjust the contrast in an image:

- 1 Select the range you want to modify.
- 2 Click the Contrast field and adjust the contrast value of the image. Increase the value to increase the contrast in the image; decrease the value to decrease the contrast in the image. The minimum value for contrast is 0, which produces a flat grey image.
- 3 Click Process to apply the changes to the clip.

Rewiring the RGB Channels

Use the Red, Green, and Blue Channel Rewiring fields to rewire the red, green, and blue channels of an image. Use the Rewire option box to create a monochrome or negative image.

When you rewire a channel, the values for the current colour channel are replaced with those of the new channel. For example, if you select the R ← G option in the Red Channel Rewiring field, the colour values of the red channel are replaced with those of the green channel.

The RGB Rewiring commands can be applied to the Master range only.

To rewire the red channel:

- 1 Select an option from the Red Channel Rewiring box.

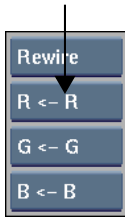

Select:	To:
$R \leftarrow R$	Use colour values for the red channel.
$R \leftarrow G$	Replace colour values of the red channel with those of the green channel.
$R \leftarrow B$	Replace colour values of the red channel with those of the blue channel.
$R \leftarrow Y$	Replace colour values of the red channel with the luma of all channels.
$R \leftarrow 1-R$	Replace colour values of the red channel with its inverse. For example, 1 corresponds to the maximum value of the given colour channel. In 8 bits, this value is 255.

2 Click Process to apply the changes to the clip.

NOTE The green and blue channels are rewired in the same way as the red channel (described in the previous table).

Creating a Negative or Monochrome Image

You can convert a colour image into a monochrome or negative image using the Rewire option box.

TIP You can also convert the image manually by clicking the appropriate Rewire selection box (R, G or B) and selecting the Y option for monochrome or 1 - R for a negative image.

To convert a colour image into a monochrome or negative image:

1 Select Mono or Negative from the Rewire option box.

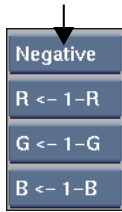

The image is automatically converted to a monochrome or negative image.

- 2 Click Process to apply the changes to the clip. To cancel the changes, click Reset Basics.

TIP You can also create a monochrome or negative image using the Monochrome and Negative buttons in the Processing menu. See [Creating a Monochrome Clip](#) on page 1440, and [Creating a Negative Clip](#) on page 1440.

Adjusting the Gamma

You can adjust the grey values of an image by adjusting the gamma. This allows you to brighten or darken an image without greatly affecting the shadows or highlights.

To adjust the gamma of the image:

- 1 Select the tonal range you want to modify.
- 2 Click a Gamma field and enter a value. Lower the gamma value to increase the contrast or raise the gamma value to decrease the contrast.

	Gamma	Gain	Offset
RGB	1.00	100	0
Red	1.00	100	0
Green	1.00	100	0
Blue	1.00	100	0

Adjusting the Gain and Offset

You can boost the colours in an image by increasing the Gain and Offset values. The Colour Corrector multiplies the pixel colour values by the Gain and then adds the Offset value. The resulting colour values are clipped at the maximum value of 255 in 8-bit mode, or 4095 in 12-bit mode.

You can also reduce the colours in the image by decreasing the Gain and Offset values. The resulting colour values are clipped at the minimum value of 0.

Gain is expressed as a percentage value. The default value of 100% has no effect on the image since the colour values are multiplied by 1.

NOTE You can adjust the Gain for individual ranges, or across all ranges simultaneously (by using the Gain fields in the Global controls). However, changes in gain mostly affect the highlights in the image.

To boost or reduce the colours in the image:

- 1 Select the range you want to modify.
- 2 Enter a value in the Gain field for the colour channel you want to modify.
- 3 Enter a value in the Offset field for the channel you want to modify.
- 4 Click Process to apply the changes to the clip.

Suppressing Colours

You can suppress the RGB or CMYw colours in an image. Chroma suppression is useful for removing blue spill from a blue-screen composite.

To suppress a colour:

- 1 Click Master.

NOTE Chroma suppression can only be applied to the Master tonal range.

- 2 Enable the appropriate button for the colour to suppress.



Enable:	To suppress:
R	Red
G	Green
B	Blue
C	Cyan
M	Magenta
Yw	Yellow

The status box on the button is light blue when the button is enabled.

NOTE Suppression of RGB and CMYw always reduces luma.

Adjusting the Colour Balance

You can adjust the colour balance in an image using the colour wheel or the Hue and Gain fields. The value of Hue determines the colour to add and the value of Gain specifies the amount of colour to use.

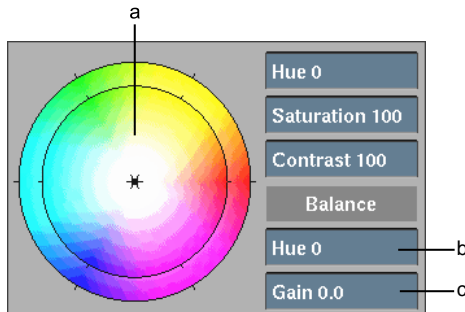

(a) Colour wheel (b) Hue field (c) Gain field

Pure red is the 0-degree point for hue on the colour wheel. When you increase the Hue value, you move counterclockwise on the colour wheel. When you decrease the Hue, you move clockwise on the colour wheel.

The centre of the colour wheel represents 0 Gain. As you increase the value of Gain, you move towards the edge of the colour wheel and add more of the selected colour to the image.

NOTE If Saturation is set to 0, no colour balancing is performed, regardless of the Gain value. In the Channel Editor, Balance channels are labelled hue_balance and gain_balance, respectively.

Creating and Modifying a Colour Balance Point

You can make colour balance points for each range (highlights, midtones, and shadows) or for all ranges simultaneously (master). Click inside the colour wheel to create a balance point for the current tonal range.

The current range's colour balance point is connected to the hub of the colour wheel by a line. You can constrain how the point is modified according to how you select it. If you select the line, the radius of the line Strength is constrained. If you select the point, the direction of the line Tint is constrained. You can make unconstrained modifications by clicking anywhere in the wheel, or by entering values in the Balance fields.

NOTE As you move the colour balance point on the colour wheel, the values in the Balance Tools Hue and Gain fields update automatically. You can also set the values for Tint and Strength directly in these fields.

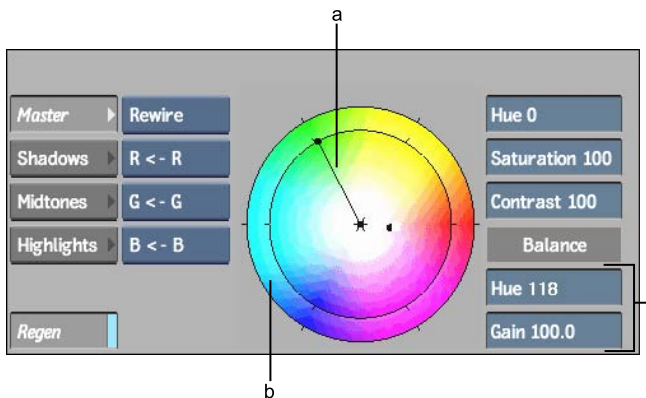

(a) Current colour balance point (b) Hue shift/saturation comparison (outside ring is Result; inside ring is Source) (c) Balance tools

Colour balancing is performed in RGB colour space. The luma of the image is not changed. For example, if Tint is set to 0 and Strength is set to 100%, pure red is added to the image. However, a black pixel remains black since it keeps the same luma value.

To change the colour balance in the image:

- 1 Enable Regen so that the image will update as you change the colour balance.
- 2 Display the Main menu.
- 3 Select the range you want to modify.
- 4 On the colour wheel, click and drag toward the colour you want to use. As you drag the cursor, a colour balance point follows the cursor. The image dynamically updates as you drag.
- 5 If you are not satisfied with the resulting image, click and drag the colour balance point again. You can continue to move the colour balance point until the desired effect is achieved.
- 6 Click Process to apply the changes to the clip.

Adjusting the Colour Range

You can use the Histogram menu to adjust the range of values used for the red, green, blue, or RGB channels of an image.

To reset any changes to the histogram, click Reset Histo. To reset all the changes in the Colour Corrector, click Reset All.

To access the Histogram menu:

- 1 Click Histogram in the Colour Corrector menu.
The Histogram menu appears.

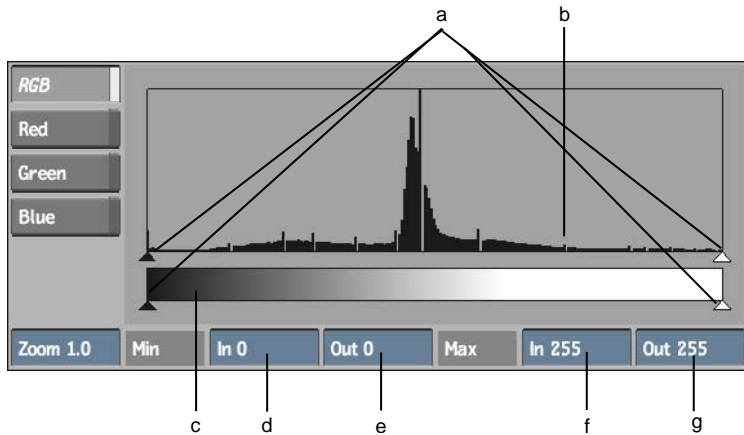

(a) Slider controls (b) Histogram (c) Gradient bar (d) Minimum Input Level
 (e) Minimum Output Level (f) Maximum Input level (g) Maximum Output level

NOTE The following description assumes you are in 8-bit mode. If you are in 12-bit mode, the default maximum input or output value is 4095.

The histogram shows the colour distribution of pixels in the front image for the selected channel. The horizontal axis represents the values of pixels, from 0 (black) at the left to 255 (white) at the right. The vertical axis represents the number of pixels with these colour values.

Increasing Image Contrast

The slider controls directly below the histogram are the Input Level controls. These controls are used to set the range of colour values used in the image:

- The white triangle on the right sets the maximum value for the range.
- The black triangle on the left sets the minimum value for the range.

You can use the Input Level controls to increase the contrast in the image. For example, if you set the minimum value to 50, pixels with colour values less than 50 are remapped to 0 (black). Pixels with colour values greater than 50 are left unchanged. This darkens the image and increases the contrast in the shadow areas.

If you set the maximum value for the range to 150, pixels with values greater than 150 are remapped to 255 (white). Pixels with colour values less than 150

are left unchanged. This brightens the image and increases the contrast in the highlight areas.

You can also set the maximum and minimum limits for the colour range by entering the values directly in the Minimum and Maximum Input fields on either side of the histogram.

To increase the contrast in an image:

- 1 Display the Histogram menu.
- 2 Click the Master, Shadows, Midtones, or Highlights button to select the parts of the image you want to modify.
- 3 Click the RGB, Red, Green, or Blue button to select the channel you want to work with.
- 4 Position the cursor on the black triangle below the histogram. Drag right to darken the shadow areas in the image.
The value of the lower limit for the colour range appears in the Minimum Input field.
- 5 Position the cursor on the white triangle below the histogram. Drag left to brighten in the highlight areas in the image.
The value of the upper limit for the colour range appears in the Maximum Input field.

NOTE If you are in RGB, you can invert the image by reversing the order of the black and white triangles.

- 6 Click Process to apply the changes to the clip. To cancel the changes, click Reset Basics.

Reducing Image Contrast

The slider controls on the gradient bar below the histogram are the Output Level controls. These controls are used to set the range of colours used in the image:

- The white triangle on the right sets the maximum value for the range.
- The black triangle on the left sets the minimum value for the range.

You can use the Output Level controls to decrease the contrast in the image. For example, suppose that you set the minimum value to 100. A pixel with a colour value of 0 is remapped to 100. Pixels with colour values greater than 0 are remapped to the appropriate values. This has the effect of lightening the image and decreasing the contrast in the shadow areas.

Suppose that you set the maximum value for the range to 200. A pixel with a colour value of 255 is remapped to 200. Pixels with colour values less than 255 are remapped to the corresponding values. This has the effect of darkening the image and decreasing the contrast in the highlight areas.

You can also set the maximum and minimum limits for the colour range by setting the values directly in the Minimum and Maximum Output fields.

To reduce the contrast in an image:

- 1 Display the Histogram menu.
- 2 Click the Master, Shadows, Midtones, or Highlights button to select the parts of the image you want to modify.
- 3 Click the RGB, Red, Green, or Blue button to select the channel you want to work with.
- 4 Position the cursor on the black triangle below the Output Level bar. Drag right to lighten the shadow areas in the image.
The value of the lower limit for the colour range appears in the Minimum Output field.
- 5 Position the cursor on the white triangle below the gradient bar. Drag left to decrease the brightness in the highlight areas.
The value of the upper limit appears in the Maximum Output field.

Defining Luma Ranges

Use the histogram in the Ranges menu to modify the shadow, midtone, or highlight ranges. Click the Ranges button in the Colour Corrector menu to display the curves for the three luma ranges. The X-axis is luma and the Y-axis is weight. The shadow curve is labelled “S”, the highlight curve is labelled “H”, and the midtone curve is not labelled.

To reset any changes to the Ranges chart, click Reset Range. To reset all the changes in the Colour Corrector, click Reset All.

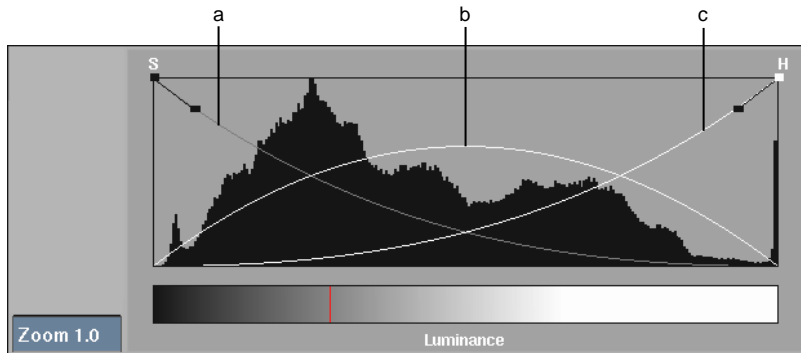

(a) Shadows (b) Midtones (c) Highlights

To see the effect of adjusting these curves:

- 1 Display the Colour Balance menu. Adjust the colour balance for each of the Shadows, Midtones, and Highlights channels. Note the effect that this setup has on the image.
- 2 Display the Ranges menu. Adjust the curves using the tangent handles. You should see that the resulting image is different from that in step 1. The difference is the result of the changes you made to the luma curves for the shadows, midtones, and highlights.

Remapping Colour Values

Like the Histogram menu, the Curves menu allows you to remap the colour values for the individual red, green, blue, and RGB channels of the image. However, instead of adjusting the colour values by resetting just the maximum and minimum values for the colour range, the Curves menu allows you to remap any value in the colour range precisely.

To reset any changes to the Ranges chart, click Reset Curve. To reset all the changes in the Colour Corrector, click Reset All. The Curves menu also has its own Undo button that is separate from the overall Colour Corrector Undo.

To access the Curves menu:

- 1 In the Colour Corrector menu, click Curves.

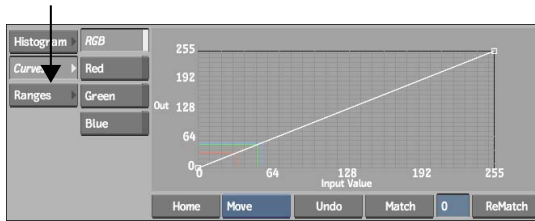

Colour Curves

There is one colour curve for each of the red, green, blue, and RGB channels of an image. The colour curves are generated by plotting the input values for the source image versus the output values for the resulting image. The input values range from 0 to 255, and are plotted along the horizontal axis. The output values range from 0 to 255, and are plotted along the vertical axis. The range for both the input values and the output values is from 0 to 255 in 8-bit mode, and from 0 to 4095 in 12-bit mode.

The default curve for each channel is a diagonal line that extends from the lower-left corner to the upper-right corner of the graph. The default curve represents the initial state in which the colour values for the pixels of the source image are equal to the values for the corresponding pixels of the resulting image. For example, all pixels that have a value of 100 in the source image also have a value of 100 in the resulting image.

The colour values of an image are remapped when you change the shape of a colour curve. You can use the Curves Editor to add, delete, or move vertices on the curve. For example, move the end vertices on the curve to change the maximum and minimum values for the colour range. Add a vertex anywhere on the curve to remap a particular colour value.

The Curves Editor behaves in much the same way as an animation curve in the Channel Editor. To edit colour curves, select Add, Delete, or Move from the Edit Mode box.

Animating a Colour Correction

Use the Animation controls to animate a colour correction that has been applied to a clip. You can animate any value in the Colour Corrector. See [Creating Animations](#) on page 1971.

To access the Animation controls:

- 1 In the Colour Corrector menu, click Animation.

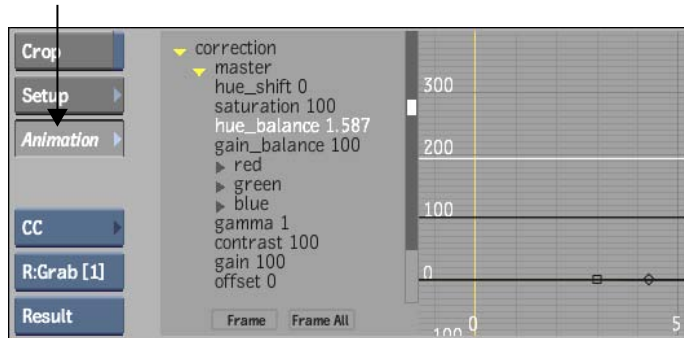

Processing Colour Changes

After you adjust the colours to your satisfaction, you are ready to process the clip. The destination resolution is the same resolution as the source clip.

Before you process the colour changes, you can preview the result clip in the image window.

To apply the colour changes to the front clip:

- 1 In the Colour Corrector menu, click Process.
The processed clip is saved on the Desktop.

- 2 Click Exit in the Colour Corrector to return to the Desktop.

If you entered the Colour Corrector from another module, you must return to that module to process the clip. If you are in the timeline, a black line appears on the timeline element to indicate that the clip has been processed.

Topics in this chapter:

- [About the Colour Warper](#) on page 1483
- [Accessing the Colour Warper](#) on page 1485
- [Setting Up Your Work Environment](#) on page 1488
- [Sampling Clips in the Image Window](#) on page 1501
- [Selecting Colour Ranges for Colour Correction](#) on page 1502
- [Correcting Colour Imbalances](#) on page 1510
- [Improving Contrast](#) on page 1515
- [Matching Colours in Clips](#) on page 1523
- [Performing Hue Shifts](#) on page 1526
- [Creating Colour Casts](#) on page 1527
- [Readjusting Colour After a Colour Correction](#) on page 1528
- [Removing Colour Spill](#) on page 1529
- [Creating Subsets](#) on page 1531

About the Colour Warper

When you colour correct an image or clip, use the Colour Warper to perform advanced colour corrections and create artistic colour effects. The way in which you approach these tasks depends on your goal, the number of clips you are using, and the type of clips being used.

Clips created from source material shot with the same camera equipment under the same lighting conditions may be colour corrected quickly and easily to correct lighting and colour imbalances. Clips created from source material shot at different times of the day, in different seasons, at different locations, or using different equipment require more work. With the Colour Warper, you can manipulate colours with precision and ease, working on the entire clip as you would with traditional tools or working with a matte to adjust a range of colour in the clip.

Use the Colour Warper to gesturally set black and white levels, adjust specific colours and colour ranges, and accurately match colours in one clip to another. You can also perform hue shifts and suppress colour to remove colour spill or create visual effects such as a colour cast. While you manipulate the colour content of a clip, you can monitor reference clips as well as changes in the colour distribution to ensure that you achieve the result you want. Original data is always preserved, so you can adjust colours without the risk of permanently losing colour information.

Colour Clamping

Clamping occurs when colours go beyond the RGB range and colour information is lost. In the Colour Warper, however, lost colour information can be retrieved. For example, if you clip colours using the white level, it is still possible to retrieve highlights that are clamped using various controls (including the trackballs) in the Basics menu.

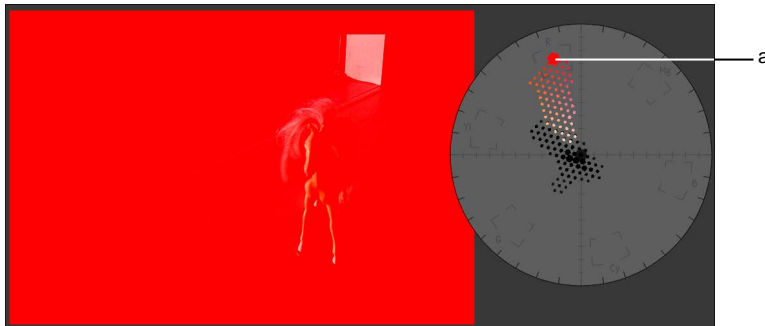

(a) Clamped colour

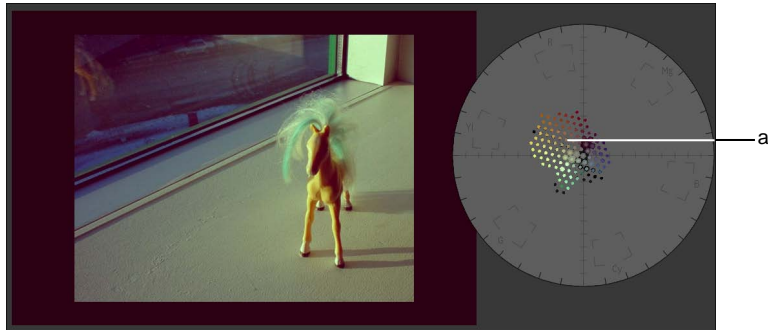

(a) Colour information restored

Accessing the Colour Warper

Use the Colour Warper to modify the colour content in your clips. You can manipulate colour content with intuitive controls that provide precise colour correction, and view histograms that help you visualize your image's colours. You can also output a matte corresponding to selected colours.

You can access the Colour Warper as a node that you drag and drop into the Batch process tree or the Modular Keyer's processing pipeline. Access the Colour Warper from the Modular Keyer to remove colour spill, or access it from Batch to modify the colour content of your clips.

You can also access the Colour Warper from the Colour Corrector module. When you access the Colour Warper from the Colour Corrector, they work in parallel—you can colour correct clips with the Colour Corrector and Colour Warper, and then compare the results. Each setup is saved separately.

You should be familiar with using the Batch schematic and the Modular Keyer processing pipelines before using the Colour Warper if you access it from either of these places. See [Batch Processing](#) on page 1283 and [Modular Keyer](#) on page 1603.

To add a Colour Warper node in Batch:

- 1 In the Main menu, click Processing.
- 2 In the Processing menu, click Batch, and then select a destination reel.
- 3 Drag the Colour Warper node from the node bar and add it to the schematic.
- 4 Input a front clip, a matte clip, or both into the Colour Warper node.

TIP Use a matte clip when you want to colour correct part of the front clip. Only the part of the front clip that is defined by the white part of the matte clip will be affected.

- 5 If you use both a front and matte clip, make sure they are the same resolution. If they are not, resize them. See [Resizing in Batch](#) on page 668.
- 6 Click the Colour Warper node to display the Colour Warper menu.

To add a Colour Warper node in the Modular Keyer:

- 1 Do one of the following:
 - In the Main menu, click Effects, and then click Modular Keyer.
 - In Batch, drag the Modular Keyer node from the node bar and add it to the schematic.
- 2 Select a front, back, and key-in clip. Make sure they are all the same resolution. If they are not, resize them. See [Resizing in Batch](#) on page 668 or [Resizing in the Resize Module](#) on page 667.
- 3 Select a destination reel.
- 4 Drag the Colour Warper node from the node bar and add it to the schematic.
- 5 Click the Colour Warper node.

To access the Colour Warper from the Colour Corrector:

- 1 Access the Colour Corrector. See [Accessing the Colour Corrector](#) on page 1452.
- 2 Select CW in the Colour box.

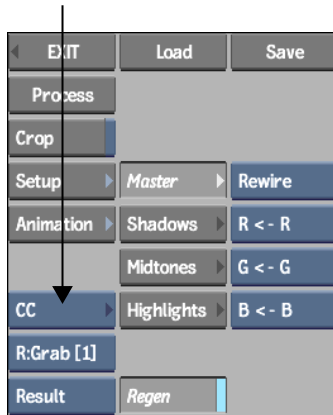

The Colour Warper menu appears.

NOTE When you want to use the Colour Warper in Batch or the Modular Keyer, use the Colour Warper node. You cannot access the Colour Warper through the Colour Corrector when you access it in Batch or the Modular Keyer.

You can access the following menus from the Colour Warper menu.

Basics menu Colour correct your clips. You can adjust shadows, midtones, and highlights, and control black and white levels, hue, and saturation. You can also perform colour warping, colour suppression, and colour saturation on a limited range of colour as well as adjust gamma and luminance curves.

Selective menu (part of Basics menu) Define colour ranges using softness and tolerance to create a matte and apply colour correction to a selected region.

Subsetups menu Store, compare, and share Colour Warper subsetups.

Setup menu Customize your work environment by adjusting vectorscope and hue cube settings, updating colour information, cropping the area you want to colour correct, and inverting a matte.

NOTE If you are accessing the Colour Warper from Batch or the Modular Keyer, you use the Setup menu for the node to adjust vectorscope and hue cube settings, as well as update colour information. You cannot use the Setup menu for the node to crop the colour correction area or invert a matte.

Setting Up Your Work Environment

Set up your work environment to streamline the colour correction process. Use the tools provided to examine the clip or image and efficiently perform advanced colour corrections. As your work progresses, you can modify the Colour Warper environment to suit the task at hand.

You can:

- Display multiple viewports.
- View reference clips.
- View the colour and luma content of a source (front) clip and result clip.
- Apply a colour correction to all or part of a clip.
- Crop the colour correction area (when accessed from the Colour Corrector).
- Invert the matte (when accessed from the Colour Corrector).
- Dynamically update colour information as you work.
- Reset entire colour corrections.
- Clear or reset individual values.
- Save and load colour correction setups and preferences.
- Use the Undo/Redo list.

Multiple Viewports

When working in the Colour Warper, you can display up to four viewports at a time in the image window, including a view of the Channel Editor. Multiple viewports are convenient when you want to modify colour values, create mattes, and compare your result with other images in different viewports simultaneously. See [Displaying Multiple Views](#) on page 136.

Reference Clips

You can use the split bar to view a reference clip while you work. Reference clips are useful when you want to match one clip to another. Carefully selecting a suitable reference clip will help you make your colour corrections quickly and efficiently. For example, you can use a reference clip from the Batch

schematic to match saturation, whites and blacks, or colours. You can also switch between different references to ensure continuity throughout the project. See [Displaying the Reference Area](#) on page 131.

Viewing Colour Information with a Vectorscope

In the Colour Warper, you can use a *vectorscope* to help match colours, adjust shadows and highlights, view colour distribution, and ensure that broadcast standards are met. There are two vectorscopes in the Colour Warper: the 2D vectorscope and the 3D vectorscope. The vectorscopes show the changes you make to colour content in a clip or image.

Each vectorscope can display:

- A histogram showing the distribution of image pixels across luma and hue ranges. When Regen is enabled, the histogram dynamically updates to reflect your changes as you modify colours in the image.
- Source and destination colours. Source colours are the colour values in the front clip and destination colours are the colour values in the result clip.
- Plotted and reference colours that are obtained by sampling images in the image window. See [Sampling Clips in the Image Window](#) on page 1501.

NOTE The 2D and 3D vectorscopes only appear in Result view.

To view colour information in either the 2D or 3D vectorscope:

- 1 In the Colour Warper menu, enable Scope.

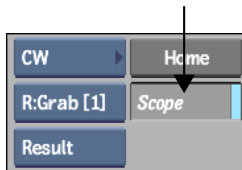

The vectorscope appears in the image window.

NOTE You can only view one vectorscope at a time.

- 2 Click Setup.
- 3 From the Scope box, select the vectorscope you want to use to view the clip.

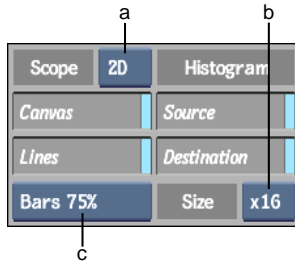

(a) Scope box (b) Size box (c) Bars box

NOTE This illustration shows the Colour Corrector Setup menu when accessed from the desktop. The Setup menu has a different layout when accessed from Batch and the Modular Keyer.

2D Displays the 2D vectorscope. Use the 2D vectorscope to analyse the colour content of the clip and locate specific colours in terms of their chroma values. When you view a clip in the 2D vectorscope, you see it in terms of hue and saturation. The size and placement of the colour squares in the 2D vectorscope show the distribution of all the colours in the clip—like a colour wheel; the distance from the centre to the perimeter of the scope maps colour saturation, with the outside edge of the scope delineating pure colour.

3D Displays the 3D vectorscope. Use the 3D vectorscope to both analyse the colour content of the clip and to locate specific colours in terms of their chroma and luma values. When you view a clip in the 3D vectorscope, you see it in terms of HLS (hue, lightness, and saturation). Its X, Y, and Z axes represent red, green, and blue, and the size and placement of the colour cubes show the distribution of all the colours of the clip in RGB colour space.

The selected vectorscope is displayed in the image window. As you scroll through a clip, the histogram is updated to display the colour distribution of each frame.

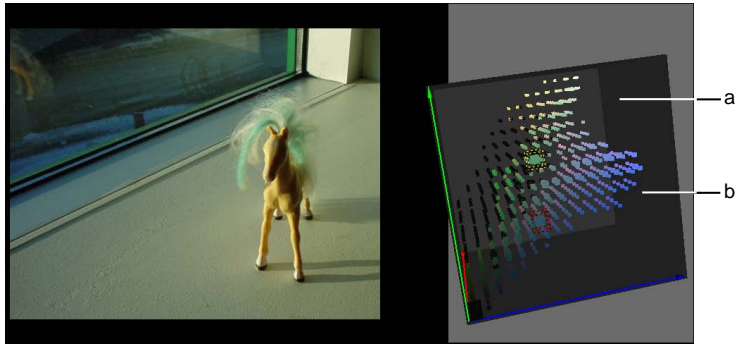

(a) 3D vectorscope (b) 3D histogram

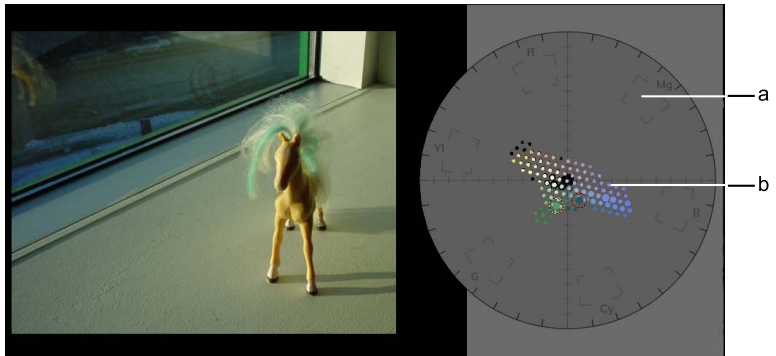

(a) 2D vectorscope (b) Histogram

- 4 Set the following options to customize the display of the 2D or 3D vectorscope.

Enable:	To:
Canvas	Show the vectorscope canvas. When the canvas is off, the vectorscope is transparent, but can be outlined.
Lines	Show the vectorscope outline.

5 Set the following options to show clip colour information.

Enable:	To:
Source	Show a histogram of the colour values in the front, or source clip. The source colour values are obtained from the current frame. If you input both front and matte clips, the colour values in the front clip that are defined by the white part of the matte are displayed.
Destination	Show a histogram of the colour values in the result clip. The destination colour values are obtained from the current frame. If you input both front and matte clips, the colour values in the front clip that are defined by the white part of the matte are displayed.

When both Source and Destination are enabled, you see both the source and destination colour values. The source clip's colour values are displayed in black and the result clip's colour values are displayed in colour. When only Source is enabled, the source clip's colour values are displayed in colour.

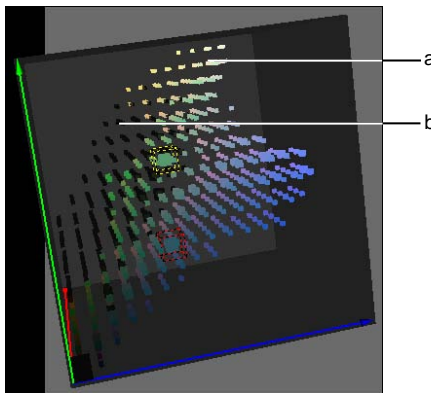

(a) Result clip (in colour) (b) Source clip (in black)

NOTE You can also toggle the Source and Destination buttons in the Basics menu to show or hide source and destination colours in the histograms.

6 From the Size box, select the size of the coloured squares or cubes that make up the histogram. You can display 8x8, 16x16, or 32x32 coloured dots.

- To set SMPTE bars for the 2D vectorscope, select an option from the Bars box.

Select:	To match:
Bars 75%	75% SMPTE bars. If the current project is NTSC, the bars are set to 75% by default.
Bars 100%	100% SMPTE bars.

The parameters of the histogram of the 2D vectorscope update accordingly.

- To toggle between the vectorscopes, double-click the vectorscope in the image window.
- To move a vectorscope, **Alt**-drag it.

NOTE You can view a vectorscope only on the right side of the image window.

- To zoom a vectorscope, **Shift**-drag it.
- To rotate the 3D vectorscope, **Ctrl**-drag it.

NOTE If you **Ctrl**-drag the 2D vectorscope, the 3D vectorscope appears and rotates.

- To position a vectorscope at its default location and size, click Home.

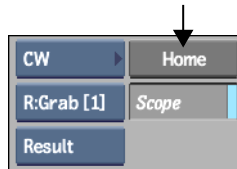

Viewing Luma Information with the 2D Luma Histogram

The 2D luma histogram shows the changes you make to luma content in a clip. Use the 2D luma histogram when you want to adjust the lightness of a sample. The 2D luma histogram is displayed in the Basics menu of the Colour Warper.

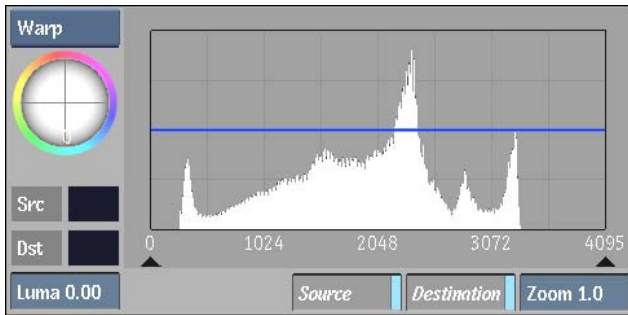

The 2D luma histogram can display:

- A histogram showing the distribution of image pixels across the luma range—the size and distribution of the vertical bars show the luma distribution.
- Source and destination colour values. Source colour values are the luma values in the front clip and destination colours are the luma values in the result clip.
- Plotted and reference colours that are obtained by sampling images in the image window. See [Sampling Clips in the Image Window](#) on page 1501.

To view luma information in the 2D luma histogram:

- 1 In the Colour Warper menu, click Basics.

The 2D luma histogram appears in the Basics menu. R, G, and B values that are modified by the Midtones trackball are displayed as curves in the histogram.

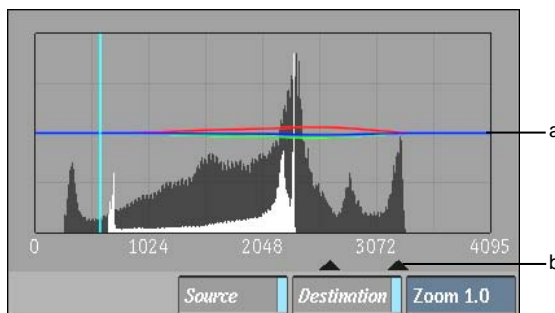

(a) RGB curves (b) Midtone triangle

2 Set the following options to show clip luma information.

Enable:	To:
Source	Show a histogram of the luma values in the front, or source, clip. The source luma values are obtained from the current frame.
Destination	Show a histogram of the luma values in the result clip. The destination colour values are obtained from the current frame.

When both Source and Destination are enabled, you see both the source and destination luma values in the histogram. Source clip colour values are displayed in black and result clip colour values are displayed in off-white.

NOTE You can also toggle the Source and Destination buttons in the Setup menu to show or hide source and destination colours in the histograms.

Colour Correcting All or Part of an Image

Use the options in the Work On box to apply colour corrections to all or part of an image. You can select an option from the Work On box at any time to further modify the image. Use Master to apply colour corrections to the entire image and use a selective to generate a matte and perform selective colour correction—apply the colour correction to a selected range of colour. The Work On box is available in every menu of the Colour Warper.

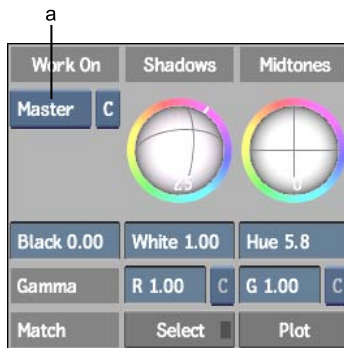

(a) Work On box

To colour correct all or part of a clip:

- 1 Select an option from the Work On box.

Select:	To:
Master	Use the Basics menu to modify the entire image. In Master mode, you cannot output a matte.
Sel. 1, Sel.2, or Sel. 3	Generate a matte from the front clip selective colour correction. You can then use the Basics menu to modify the range of colour defined by the matte. In a selective mode, you can output the matte, selective, or result. See Selecting Colour Ranges for Colour Correction on page 1502.

Cropping the Colour Correction Area

When you access the Colour Warper from the Colour Corrector, you can create a crop box to limit the area where the colour correction is applied.

Using a crop box as you colour correct a clip speeds up interactivity, which is especially useful when working at high resolutions. You can also process the clip with a crop box. Everything outside the crop box will be processed as black on the matte.

To use a crop box:

- 1 In the Colour Warper menu, click Setup.
- 2 Do one of the following:
 - Hold down the **Ctrl** key or hold the pen button and drag the box across the image.
 - Turn on the Crop button and enter the dimensions for the crop box in the Left, Right, Bottom, and Top fields.



The crop box appears in the image window. By default, the crop box has the same dimensions as the clip. The display inside and outside the crop box depends on how many clips are loaded.

If you loaded:	Inside the crop box:	Outside the crop box:
A front, back, and matte clip	Shows the front clip in the opaque area of the matte and the back clip in the transparent area of the matte.	Shows the back clip.
A front and back clip	Shows the front clip.	Shows the back clip.
A front clip only	Shows the colour-corrected clip.	Shows the non-colour corrected clip.

- 3 To adjust the size of the crop box, drag on the corner points of the box, or modify the values in the Left, Right, Bottom, and Top fields in the Setup menu.
- 4 To move the crop box in the image window, click a side of the box and drag to a new location. Alternatively, press **Ctrl** and redraw the crop box.
- 5 You can now use any Colour Warper menu and colour correct the area of the clip that is defined by the crop box. You will only see the results of your changes within the crop box.
- 6 If you want to process the clip with the crop box, leave the Crop button enabled when you process.

To disable a crop box:

- 1 From any Colour Warper menu, disable Crop.
When you disable the Crop button in a Colour Warper menu, the Crop button in the Setup menu is also disabled.

To change the colour of the crop box:

- 1 In the Colour Warper Setup menu, click the colour pot beside Border.

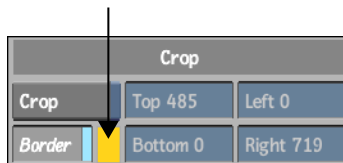

The colour picker appears.

- 2 Select a colour with the colour picker.
- 3 Click in the Border colour pot to apply the new colour to the border.

To hide the crop box:

- 1 In the Setup menu, disable Border.

Inverting the Matte

When you access the Colour Warper from the Colour Corrector and you input a front, back, and matte clip, you can invert the matte to colour correct the region outside the area defined by the matte. Inverting the matte swaps the transparent and opaque areas of the matte and redefines the area of the front image that can be colour corrected, as well as the area of the back image that is shown. To invert a matte, enable the Invert Matte button in the Setup menu.

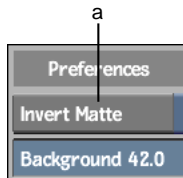

(a) Invert Matte button

Resetting Colour Corrections

When you access the Colour Warper from the Colour Corrector, you can reset colour corrections created with the Colour Warper, the Colour Corrector, or both.

To reset a colour correction:

- 1 In the Colour Warper menu, select an option from the Reset box.

Select:	To reset:
Reset All	The entire module. Both the Colour Corrector and Colour Warper settings are reset to their default values.

Select:	To reset:
Reset CC	The Colour Corrector. Settings in the Colour Warper are not affected.
Reset CW	The Colour Warper. Settings in the Colour Corrector are not affected.

2 Click Confirm.

Resetting and Clearing Values

You can clear or reset several Colour Warper values in the Basics menu using individual C/R boxes. C resets the value for the current frame by setting a keyframe. R resets the value for the entire animation curve.

To reset a Colour Warper value:

- In the Basics menu, do one of the following:
 - Select C from the C/R box next to a control.

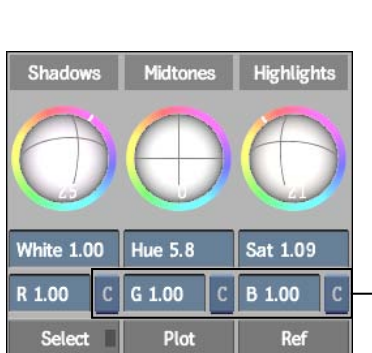

The value is reset at the current frame.

- Select R from the C/R box.

The value is reset for the entire animation curve.

NOTE Fields that do not have C/R boxes next to them cannot be reset. Use the Undo box instead.

Saving Colour Correction Setups and Preferences

You can save or load colour correction setups using the Save or Load button. Any setup can be loaded from the file browser for use with another set of clips. You can also save or load colour correction preferences using the Load or Save button.



- To save setups or preferences, click Save.
- To load setups or preferences, click Load.

TIP Click Revert to revert to the last saved setup. All changes made since the previous Save operation are undone.

When you save colour correction setups, you save the current settings for both the Colour Corrector and the Colour Warper to the setup file. If you overwrite a setup file using the Save button, the current settings in both the Colour Corrector and Colour Warper are saved.

For more information, see [Saving Setups and Preferences](#) on page 799.

Using Undo and Redo

Use the Undo and Redo boxes to remove or redo colour modifications. To undo or redo a modification, click a box and select an option from the list. Set the number of undo levels in the Setup menu.

NOTE You also set the number of undo levels for the Modular Keyer in the Setup menu of the Batch module.

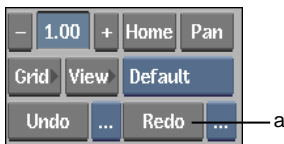

(a) Redo option box

Sampling Clips in the Image Window

When you generate mattes, modify clips, or match colours between clips, you can sample colours in both the result clip and a reference clip. Use Plot to sample a colour from the result clip and Ref to sample one from a reference clip. The Plot and Ref buttons appear on every menu in the Colour Warper.

NOTE Ref samples cannot be adjusted.

Samples appear in the histograms. In the 2D luma histogram, the Plot sample is represented by a red bar and the Ref sample is represented by a yellow bar.

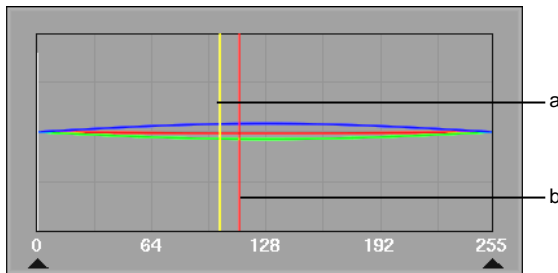

(a) Reference colour (yellow vertical line) (b) Plotted colour (red vertical line)

In the vectorscope, the Plot sample is outlined in red and the Ref sample is outlined in yellow.

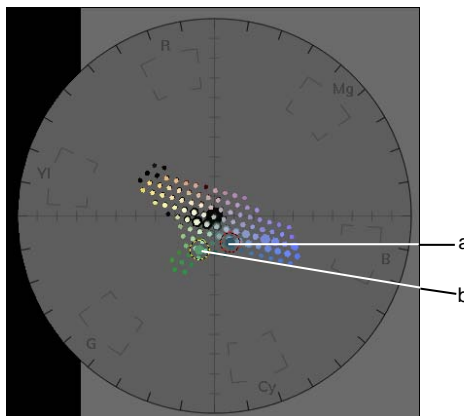

(a) Plotted colour (outlined in red) (b) Reference colour (outlined in yellow)

You can use Plot to get more information on colours you want to change. When you are adjusting colours and levels and are not sure which controls

to use, click Plot and select a colour in the image. You can then view the histograms to determine which control you should use. For example, if the plotted colour appears in the middle of the 2D luma histogram, you can modify the colour in the image using the Midtones trackball while viewing the plotted colour in the 2D vectorscope.

To sample clips:

- 1 Load a reference clip and position the split bar so that both the reference clip and the result clip appear in the image window. See [Displaying the Reference Area](#) on page 131.
- 2 Do one or both of the following:
 - Enable Plot and then sample the result clip.

You can:	To:
Click-drag	Sample a single pixel in the image. You can drag through the image until you locate the pixel you want to sample.
Ctrl-drag	Sample an average taken from a range of colours in the image.

A red vertical line appears in the 2D luma histogram indicating the luma of the sample. The sampled colour is also outlined in red in the 2D or 3D vectorscope. In the 2D vectorscope, you see the sample in terms of hue and saturation. In the 3D vectorscope, you see it in terms of HLS.

- Enable Ref and then sample the reference clip.

You can:	To:
Click-drag	Sample a single pixel in the image. You can drag through the image until you locate the pixel you want to sample.
Ctrl-drag	Sample an average taken from a range of colours in the image.

A yellow vertical line appears in the 2D luma histogram and the sampled colour is outlined in yellow in the 2D or 3D vectorscope.

Selecting Colour Ranges for Colour Correction

With some images or clips, you may need to perform selective colour correction—where you modify a range of colour, as opposed to the entire clip or image. Use the tools in the Selective menu to create selectives. Selectives

are generated mattes used to isolate colour ranges for selective colour correction.

In the Selective menu, you can:

- Create and refine a matte using tolerance and softness to define the range you want to modify.
- View a matte, a selected colour range, or the result.
- Enable mattes to apply the selective colour correction to the result image. Disable mattes to remove the selective colour correction from the result image.

TIP Set the image window to 2-Up view (**Alt+2**) so that you can create your matte in one viewport while simultaneously monitoring the result in the other.

Generating Mattes

Mattes can be used for several purposes. For instance, use a matte to remove colour spill, hue shift an object in an image for artistic effect, or match colours in a specific range. You can also output a matte for use in other modules such as Action or the Keyer. Use mattes to define the range of colour you want to modify in the result clip.

You can generate up to three mattes using the Selective menu.

TIP To get the best key, make sure you have enough processing speed to see the result in real time while interacting with the Tolerance and Softness boundary handles. In the Modular Keyer, you can use the Crop feature to improve interaction. See [Cropping the Key Area](#) on page 1627.

To generate a matte for selective colour correction:

- 1 Enable Plot and then sample the image.
A black dot representing the sample appears on the hue cube. A red line also appears in the luma range and the sample is outlined in the 2D or 3D vectorscope. When you create the matte, you can modify the softness and tolerance boundaries to include or exclude the plotted colour.
- 2 From the Work On box, select a selective (Sel 1, Sel 2, or Sel 3). With each selective, you define a range for a matte by selecting colours in the front clip.

- From the Selective View box that appears, select Sel.

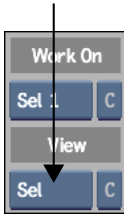

The front clip is displayed as a greyscale image.

- Click one of the Define controls to set the initial softness and tolerance for the matte.



Click:	To define:
Pick Custom	The tolerance range based on a sample from the image. You must drag the cursor over the image to define initial tolerance.
R, G, B, C, M, or Yw	The tolerance range based on the selected colour channel. For example, click Yw to use the yellow channel to set the tolerance. The luma range is set to default tolerance and softness values.
Shadows, Midtones, Highlights	The tolerance range based on the selected luma range. These buttons expand the tolerance and softness boundaries to include all ranges of colours in the image.

The initial softness and tolerance is set for the matte. The range you use to define the matte becomes visible through the greyscale image. The unselected colours remain greyscale.

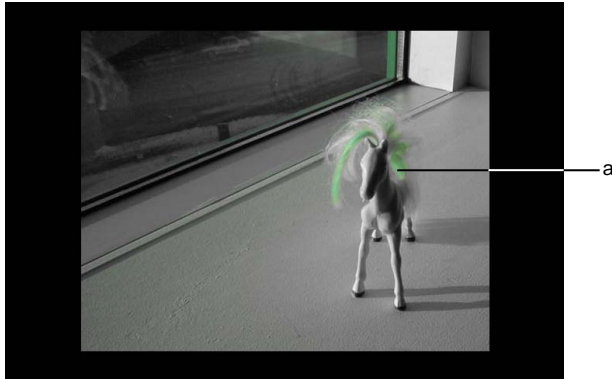

(a) Original colour visible through the greyscale display.

The Active button associated with the selective is enabled when you set the initial softness and tolerance. When an Active button is enabled, the selective's matte will be applied to the result clip. You can disable the Active button at any time if you do not want to apply this matte to the result clip.

TIP To redefine a matte based on a different Define control, click the control you want to use. The matte will be reset according to your selection.

5 Enable Tolerance and Softness.

The range of colour used to define the matte is shown on the hue cube with tolerance and softness indicators. The light grey outline shows tolerance and the black outline shows softness. When you define a matte with a luma range, it is shown in the luma range—the white line indicates the tolerance and the yellow, softness.

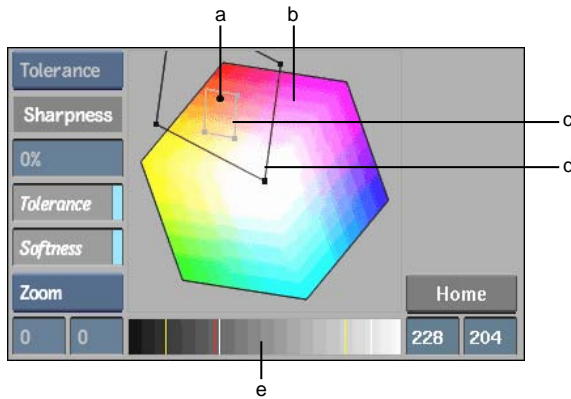

(a) Plotted colour (black dot) (b) Hue cube (c) Tolerance range (d) Softness range (e) Luma range

TIP Click Home to reset the hue cube to its original size and position.

- To view the matte while you refine it, select Matte from the Selective View box.

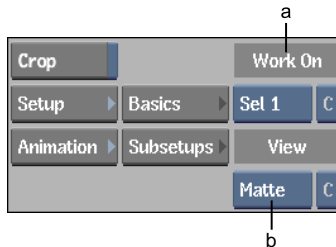

(a) Work On box (b) Selective View box

The matte appears in the image window. The black and grey areas of the matte can be colour corrected. The white areas will remain unaffected.

TIP Select Matte view to output a matte for use in another module in Batch. The selective must also be selected in the Work On box.

7 To refine the matte, do any of the following:

- Adjust softness and tolerance by selecting options from the Adjusting box and then sampling the result clip.

Select:	To:
Tolerance	Add tolerance to the matte.
+Softness	Add softness to the matte.
-Softness	Remove softness from the matte.

- Adjust softness and tolerance by selecting Move from the Move/Zoom box and then moving the handles of the tolerance or softness outlines on the hue cube. The T and S buttons must also be enabled.

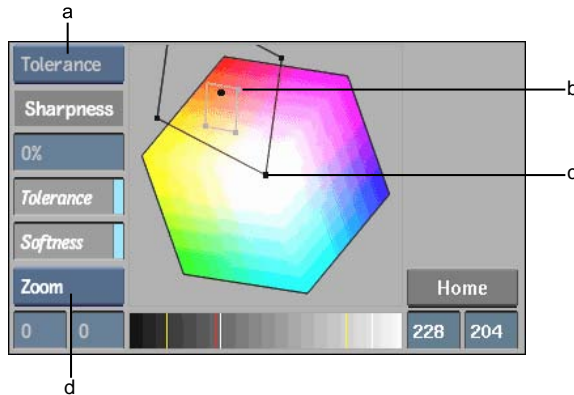

(a) Adjusting box (b) Tolerance handle (c) Softness handle (d) Move/Zoom box

TIP You can zoom the hue cube by selecting Zoom in the Move/Zoom box and then dragging the cube. Alternatively, **Shift**-drag to zoom.

- Adjust the softness and tolerance in the luma range by dragging the Softness and Tolerance fields.

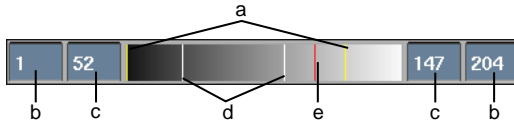

(a) Softness range (b) Softness field (c) Tolerance field (d) Tolerance range (e) Plot line

■ If the matte appears grainy, drag the Sharpness field to adjust softness and reduce noise.

8 To apply a Gaussian blur, enable G. To apply a box blur, disable G and set the width and height of the blur with the X and Y fields.

9 To invert the matte, enable Inv Selection.

10 Continue fine-tuning the matte until you are satisfied.

You can select the selective in the Work On box from any menu in the Colour Warper to perform advanced colour corrections on the range defined by the matte. You can also change the view in the Selective View box.

TIP When you switch from the Selective menu to any other menu in the Colour Warper, Result appears in the Selective View box. Select Result to view the result clip.

Clearing and Deleting Mattes and Colour Corrections

Use the C/R boxes next to the Work On box and Selective View box to reset a matte or a colour correction. C deletes the matte or colour correction at the current frame by setting a keyframe. R deletes the matte or colour correction for the entire animation curve.

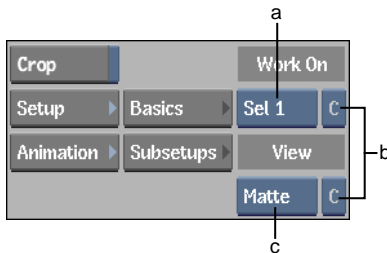

(a) Work On box (b) C/R boxes (c) Selective View box

NOTE If there is no matte or colour correction associated with the correction, the C/R button is disabled.

To delete a matte for the entire animation curve:

- 1 Select the matte from the Work On box (Sel 1, Sel 2, or Sel 3).
- 2 Select R from the C/R box next to the Selective View box.
The matte is deleted. All keyframes and colour corrections associated with the matte are also cleared.

NOTE Keyframes associated with the colour correction are not cleared.

To delete a matte at the current frame:

- 1 Select the matte from the Work On box (Sel 1, Sel 2, or Sel 3).
- 2 Select C from the C/R box next to the Selective View box.
The matte is deleted at the current frame and a keyframe is set.

To delete a colour correction for the entire animation curve:

- 1 Select a matte or the entire image from the Work On box (Master, Sel 1, Sel 2, or Sel 3).
- 2 Select R from the C/R box next to the Work On box.
The colour correction is deleted and all keyframes are cleared. If you selected a matte (Sel 1, Sel 2, or Sel 3) from the Work On box, the matte is unaffected and its keyframes are not cleared.

To delete a colour correction at the current frame:

- 1 Select a matte or the entire image from the Work On box (Master, Sel 1, Sel 2, or Sel 3).
- 2 Select C from the C/R box next to the Work On box.
The colour correction is cleared at the current frame and a keyframe is set. If you selected a matte (Sel 1, Sel 2, or Sel 3) from the Work On box, the matte is unaffected and its keyframes are not cleared.

Correcting Colour Imbalances

During production, differences in lighting and equipment often create colour imbalances in and between clips. When you work on these clips in the Colour Warper, you should perform a basic colour correction to colour balance them. You can balance colours using the tools in the Basics menu. Perform your tasks in the following order:

- Set black and white levels.
- Remove unwanted colour.

Setting Black and White Levels

When you balance the colours in a clip, you should always start with the darkest and lightest parts of the image. You may, for example, need to establish parameters for the black and white (luma) content to ensure that the intensity of the image is in accordance with established broadcast parameters. These parameters are known as *black points* and *white points*. You use the Black and White fields to establish black and white points.

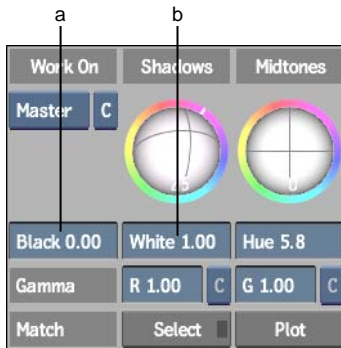

(a) Black field (b) White field

Black field Modifies the luma in the image's shadows without affecting the chroma.

White field Modifies the luma in the image's highlights without affecting the chroma.

To set black and white levels:

- 1 Sample the highlights in the image. To determine the white point, select a white that appears to be flat rather than reflective so that you obtain a more accurate reading. Do not use a highly reflective surface such as a window or metal surface as they are often too bright. Enable Plot and then sample the whites in the result clip.

In the Basics menu, a red plot line is displayed in the 2D luma histogram indicating the luma value of the sampled whites in the result clip.

- 2 While viewing the 2D luma histogram and the image, adjust the white level to modify the luma value and set the white point—drag left to darken the highlights and right to lighten them. The Plot sample is updated as you drag the field.

TIP You can view both the 2D luma histogram and 2D vectorscope to determine what adjustments you need to make to the highlights. For example, if the white point is set to an acceptable level in the 2D luma histogram but the sampled chroma value shows an unwanted colour cast in the 2D vectorscope, use the Highlights trackball to modify the chroma value in the highlights. See [Removing Unwanted Colour](#) on page 1511.

- 3 Enable Plot and sample the shadows in the result clip to determine the black level. Sample the darkest part of the image to determine the black point.

A red plot line is displayed in the 2D luma histogram indicating the luma value of the sampled blacks in the result clip.

- 4 While viewing the 2D luma histogram and the image, adjust the black level to modify the luma value—drag left to darken the shadows and right to lighten them. The Plot sample is updated as you drag the field.

TIP Once the black level is set, you can use the Shadows trackball to adjust the chroma values in the highlights while viewing the plot sample in the 2D vectorscope. See [Removing Unwanted Colour](#) on page 1511.

Removing Unwanted Colour

Unwanted colour can be caused by factors such as inconsistent lighting conditions during a shoot or incongruities between the white levels set on a video camera and the given lighting conditions. Factors such as these can result in clips or images that contain unnatural looking colours or one

predominant colour, which gives the image an unwanted colour cast. After setting black and white points, you can remove the unwanted colour without affecting the black and white levels. You can:

- Use the Shadows, Midtones, and Highlights trackballs to remove colour from the shadows, midtones, and highlights ranges.
- Use the Suppress trackball to remove a range of colour, such as a colour cast that pervades the entire image.

Not all colour casts detract from the natural appearance of the image. Before you remove a colour cast, it is best to analyse the image or clip, both in relation to other clips in the project and with an eye on maintaining the atmosphere, or mood inherent to the clip. For example, images of sunny summer days should have a reddish cast to convey an atmosphere of warmth. Completely removing the reddish cast may result in a colder feel than you want. In cases where the cast is a complementary one, you may want to refine it to improve the overall effect. See [Creating Colour Casts](#) on page 1527.

The shadows, midtones, and highlights trackballs in the Basics menu are described as follows.

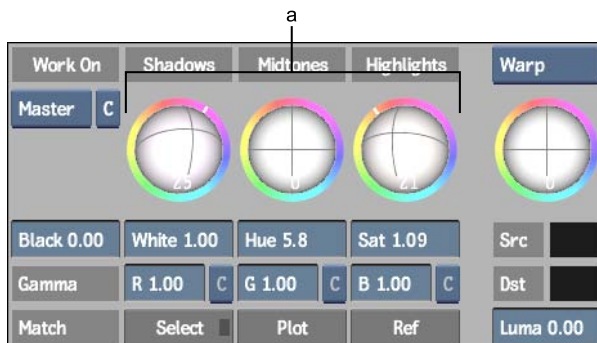

(a) Trackballs

NOTE To make the trackballs respond to changes in pressure, use the Pointer preferences in the Preferences menu. See [Pointer Preferences](#) on page 830.

Shadows trackball Modifies the chroma in the low luminance area without affecting the luma.

Midtones trackball Modifies horizontal RGB curves in the 2D luma histogram. These curves represent the amount of chroma tint you apply to the image. For example, if the red and green curves are above the middle line while the

blue curve is below the middle line, you are adding a yellow tint to the midtones components of your image.

By default, the Midtones trackball affects all ranges except white and black, as shown by the histogram's RGB curves. To set the luma range affected by the Midtones trackball, use the two midtones triangles below the 2D luma histogram. Drag the triangles closer together to decrease the range and further apart to increase it. You can modify the range as many times as you like.

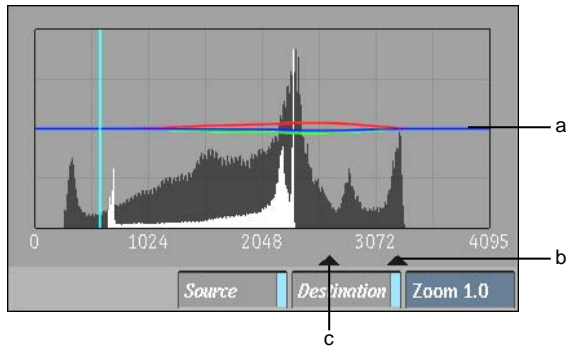

(a) RGB curves (b) Midtones triangle (c) Midtones triangle

Because you can modify the range that the Midtones trackball affects, the trackball will always return to its default reference value—when you release the Midtones trackball and apply the change, it will return to 0.

NOTE You can animate the curve using the Shape channel under Midtone in the Channel Editor. Click Animation to view the Channel Editor.

Highlights trackball Modifies the chroma in the high luminance area without affecting the luma.

To remove unwanted colour using the Shadows, Midtones, and Highlights trackballs:

- 1 Click Basics to display the Basics menu.
- 2 Enable Plot and then sample the image's highlights.

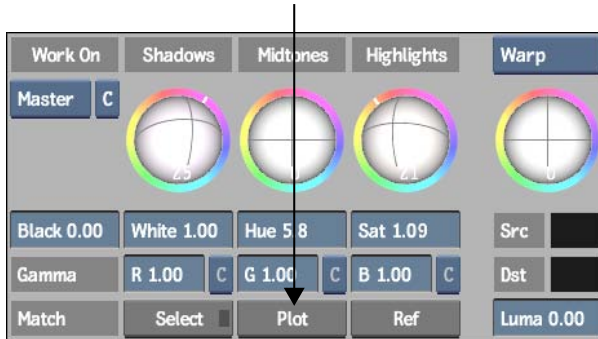

The sample (outlined in red) appears in the 2D or 3D vectorscope.

TIP You can determine the colour of a sample by dragging right in the Saturation field to temporarily increase the saturation while monitoring the sample in the 2D vectorscope. When you release the mouse, the level that appears in the field resets to its default reference value. Once you determine the cast of the colour, click Undo to reset the saturation level and then resample the image.

- 3 If necessary, double-click the 3D vectorscope to display the 2D vectorscope.
- 4 While viewing the 2D vectorscope, drag the Highlights trackball to move the sample towards the centre of the 2D vectorscope.
The chroma in the high luminance area of the clip is modified without affecting the luma.
- 5 Drag the Midtones trackball to make minor adjustments to the chroma content.

TIP Drag the left midtones triangle to decrease the range affected by the Midtones trackball. Make sure the range includes the sampled colour.

The RGB curves in the 2D luma histogram reflect the changes you make. More of the unwanted colour is removed from the image (while still preserving luma) without affecting the black and white points.

TIP To achieve true white, drag the Highlights and Midtones trackball to move the plot sample to the centre of the 2D vectorscope.

- 6 Continue modifying the highlights and midtones until you are satisfied with the result.

- 7 Enable Plot and then sample the image's shadows.
- 8 Repeat steps 2 to 6 using the Shadows and Midtones trackballs to remove unwanted colour from the shadows (and midtones) in the image.

To remove unwanted colour using the Suppression trackball:

- 1 Click Basics to display the Basics menu.
- 2 Select Suppress from the Trackball option box.

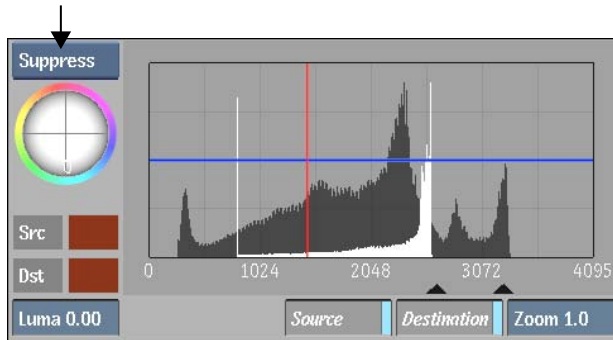

- 3 To sample the colour you want to suppress, enable Plot and then sample the image.
The sample (outlined in red) appears in the 2D or 3D vectorscope.
- 4 While monitoring the 2D vectorscope and image, drag the Suppress trackball towards the colour you want to suppress to move it closer to the centre of the 2D vectorscope. For example, to suppress yellows, move the trackball towards yellow.

TIP Disable Source and Destination to only view the sample.

- 5 Release the trackball.
- 6 To further increase the suppression of the same colour, use the trackball to move the colour closer to the centre of the 2D vectorscope.

Improving Contrast

Poor image contrast can be caused by various factors. For example, when you remove a colour cast from a clip, it may become washed out. Washed out clips

usually occur when the image contrast and saturation levels are too low. To complete the task of balancing the colours in the clip, use the tools in the Basics menu to correct the poor contrast. To improve contrast and the overall look of the clip, you can:

- Adjust the luma and chroma content in the shadows and highlights, including the black and white point.
- Increase colour saturation without changing luma.
- Modify the luma and chroma content using the Gamma controls.

Adjusting Shadows and Highlights to Improve Contrast

When there is not enough, or too much, black or white in a clip, it will lack contrast. If you want to improve the contrast by changing both the chroma and luma content, including the black and white points, use the controls in the Basics menu to adjust the shadows and highlights in the image.

To adjust the shadows and highlights to improve contrast:

- 1 Click Basics to display the Basics menu.
- 2 Enable Plot and then **Ctrl**-drag the cursor over the portion of the result clip containing black or white.
In the Basics menu, a red plot line is displayed in the 2D luma histogram indicating the luma value of the sampled blacks. In the vectorscope, you can view the saturation and hue.
- 3 Use the 2D luma histogram and 2D vectorscope to determine which controls you need to use (such as the Black field, and Shadows and Midtones trackballs).
- 4 While viewing the 2D luma histogram, adjust the black level to modify the luma value. The Plot sample is updated as you drag the field.
- 5 While viewing the 2D vectorscope, drag the Midtones and Shadows (Highlights) trackballs towards the colour you want to increase in the blacks or whites. The Plot sample is updated as you drag the trackball.

TIP To achieve true black or white, drag the Midtones and Shadows trackball to move the plot sample to the centre of the 2D vectorscope.

- 6 Continue modifying the shadows until you are satisfied with the result.

TIP View the sample in the 3D vectorscope to make more refined modifications.

Increasing Saturation

When an image is desaturated, the colours can appear washed out. To improve contrast, you can increase the colour saturation globally, saturate specific hues, or do both. Increasing saturation levels increases the colour intensity and causes minor changes to the hue. The luma content is virtually unaffected when you modify saturation.

To increase saturation globally:

- 1 Click Basics to display the Basics menu.
- 2 Drag right in the Saturation field while monitoring the 2D or 3D vectorscope and the image.

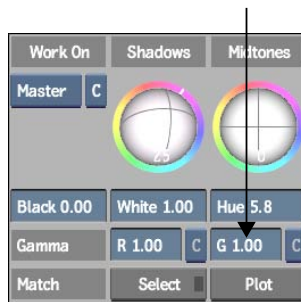

The selected colour range (or entire image) moves towards the perimeter of the 2D luma histogram. There is also an increase in colour saturation in the image.

To saturate specific hues of an image:

- 1 Click Basics to display the Basics menu.
- 2 Select Saturate from the Trackball option box.

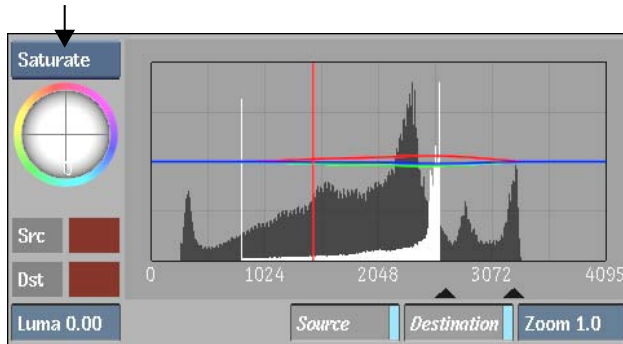

- 3 Drag the Saturate trackball towards the colour you want to saturate while monitoring the 2D vectorscope. Drag until the colour is closer to the edge of the 2D vectorscope. For example, to saturate reds, move the trackball towards red.

NOTE To make the trackballs respond to changes in pressure, use the Pointer preferences in the Preferences menu. See [Pointer Preferences](#) on page 830.

- 4 Release the trackball.
- 5 To further increase the saturation of the same colour, use the trackball to move the colour closer to the edge of the 2D vectorscope.

Improving Contrast Using Gamma

When you want to improve contrast by modifying both the chroma and luma content simultaneously without changing the black and white points, use the Gamma controls. You only need to make small adjustments to the RGB gamma curves to improve the contrast.

You can adjust the RGB gamma curves uniformly using the RGB Gamma fields.

You can also use a second set of adjustment curves to tweak each colour channel, as well as the luminance channel, regionally.

After making uniform or regional adjustments, if you are not satisfied with the result, you can reset each channel's gamma or adjustment curve, or clear edited curve values for individual frames.

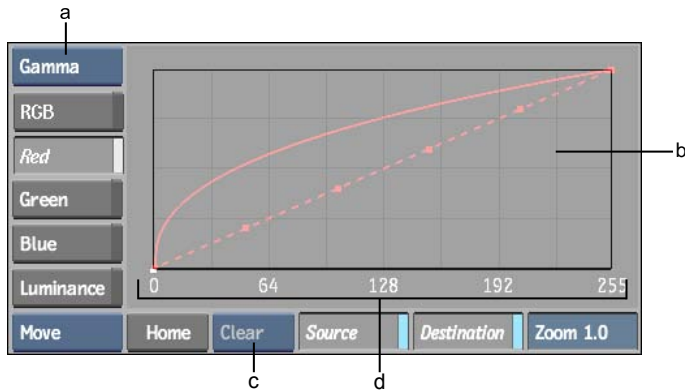

(a) Trackball option box (b) Gamma curves (c) Reset box (d) Luma range

To improve contrast using gamma:

- 1 Click Basics to display the Basics menu.
- 2 Select Gamma from the Trackball option box.
- 3 Display the gamma curve(s) you want to adjust.

Enable:	To display:
RGB	The R, G, and B gamma curves at the same time.
Red, Green, or Blue	The R, G, or B gamma curve individually.
Luminance	The Luminance curve. Use this curve to modify luminance levels locally without affecting the overall luminance.

Two curves are displayed for each channel, the original gamma curve, and an adjustment curve with control points for regional control. Initially these curves overlap.

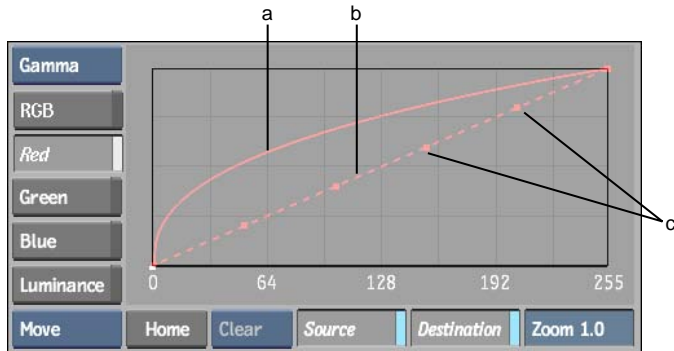

(a) Red channel's gamma curve (b) Red channel's adjustment curve (c) Added control points on adjustment curve

- 4 While monitoring the 2D vectorscope and image, make a minor adjustment to the gamma curves by doing one of the following:
 - To modify R, G, and B gamma values individually across the entire luma range (from black to white), click and drag in the Gamma R, G, and B fields. Drag left to increase contrast or right to decrease contrast. You can also enter a value directly in these fields. Enter a low value to increase contrast or a high value to decrease contrast.

Only the field you modified is updated. The gamma curves are also updated to reflect your changes. The gamma curve is offset from its dotted adjustment curve. Use the adjustment curve to make regional adjustments to the channel.



(a) RGB Gamma Fields

- To modify R, G, and B gamma values proportionally across the entire luma range (from black to white), **Alt**-drag the Gamma R, G, or B field. Drag left to increase contrast or right to decrease contrast.

All three fields are updated. The gamma curves are also updated to reflect your changes. The gamma curves are offset from their dotted adjustment curves. Use the adjustment curve to make regional adjustments to the channel.

TIP To smooth the contrast, you can increase the gamma (raise the curves) and then adjust the Black and White levels in the Basics menu.

- To modify part of the RGB gamma or luminescence range rather than the entire range, use the Edit Mode box to modify the adjustment curves.

Select:	To:
Add	Add control points to an adjustment curve. With Add selected, click either the red, green, blue or luminance adjustment curve to add a control point.
Delete	Delete control points from an adjustment curve. With Delete selected, click a point on the red, green, blue or luminance adjustment curve to delete it.
Move	Move the control points. With Move selected, drag the points to move them.

Select:	To:
Zoom	Zoom in on the curves. With Zoom selected, drag over the curves right or left to zoom in or out.
Rect Zoom	Zoom in on a section of the curves. With Rect Zoom selected, drag a selection box to zoom in on the area of the curves contained by the selection box.
Pan	Pan the curves. With Pan selected, drag over the curves to pan the curves in any direction.

After dragging control points, the image and 2D vectorscope update accordingly.

To reset RGB gamma or luminance curves for all frames in the clip:

- 1 Do one of the following:
 - To reset individual RGB gamma curves, select R in one of the Channel Reset boxes next to the Gamma R, B, or C field.

The gamma curve is reset along with its adjustment curve for all frames in the clip. Any control points added to the adjustment curve are removed.

- To reset the R, G, or B gamma value for the current frame, **Ctrl-click** the GamR, GamB, or GamC field.
- To reset RGB adjustment or luminance curve values for all frames in the clip, click one of the channel buttons (RGB, Red, Green, or Blue) or the Luminance button to display the curves you want to affect, then select Reset in the Reset box.

The values for the displayed adjustment curves or luminance curve are reset. Any control points added to the adjustment curves or luminance curve are removed.

To clear RGB gamma or luminance curve values for the current frame:

- 1 Do one of the following:
 - To clear individual RGB gamma curve values for the current frame, select C in one of the Channel Reset boxes next to the Gamma R,B, or G field.

The gamma curve value is cleared for the current frame, and the gamma curve is updated without affecting its adjustment curve. A keyframe is set with the reset values.

- To clear RGB adjustment or luminance curve values for the current frame, click one of the channel buttons (RGB, Red, Green, or Blue) or the Luminance button to display the curves you want to affect, then select Clear in the Reset box.

The values for the displayed adjustment curves or luminance curve are reset for the current frame. The curves' control points are distributed equidistantly along each curve. A keyframe is set with the reset values.

Matching Colours in Clips

You can match a sample from the result clip to one from a reference clip. Matching clips can improve continuity between clips. You can:

- Match specific colours.
- Match shadows, highlights and overall saturation.

Matching Specific Colours

You can match plot samples to reference samples using the trackballs and by aligning the colours in the vectorscope. For example, you may want to match a red in one image to a different shade of red in another clip. For information on using Plot and Ref controls, see [Sampling Clips in the Image Window](#) on page 1501.

To match specific colours:

- 1 Select Result from the View box.
The result clip is displayed in the image window.
- 2 If necessary, position the split bar so that both a reference clip and the result clip appear.
- 3 Enable Plot and then sample a colour in the clip you want to modify (the result clip).
A red plot line is displayed in the 2D luma histogram indicating the luma value of the sample. In the 2D vectorscope, you can view the saturation

and hue of the sample (outlined in red). In the 3D vectorscope, you can view the sample in terms of HLS.

- 4 Enable Ref and then sample the colour in the reference image you want to match.

A yellow reference line is displayed in the 2D luma histogram indicating the luma value of the sample. In the 2D vectorscope, you can view the saturation and hue of the sample (outlined in yellow). In the 3D vectorscope, you can view the sample in terms of HLS.

- 5 Use the 2D luma histogram in the Basics menu and 2D vectorscope in the image window to determine which controls you need to use.

Drag:	When:
White or Black field	You need to adjust the luma values in the highlights or shadows without modifying the chroma. Drag the field so that the plot line in the 2D luma histogram moves towards the reference line.
Highlights, Midtones, or Shadows trackball	You need to adjust the chroma values in the image without modifying the luma. Drag the trackball(s) so that the plot sample in the 2D vectorscope moves towards the reference sample.

- 6 Use the necessary controls to modify the clip until the plotted sample is aligned with the reference colour in the 2D luma histogram and 2D vectorscope. If necessary, increase or decrease the saturation as well as shift the hue.

TIP View the sample in the 3D vectorscope to make more refined modifications.

Matching Shadows, Highlights, or Overall Saturation

Use the Match feature to match a range of colours in the result clip to a range of colours in a reference clip. You can match highlights, shadows, or the overall saturation of an image.

NOTE Match is not designed to match specific colours.

To match shadows, highlights, or overall saturation:

- 1** Select Result from the View box.
The result clip is displayed in the image window.
- 2** Position the split bar so that both a reference clip and the result clip appear.
- 3** Click Match.
The following message appears in the message bar: "MATCHING: Select an area to be modified."
- 4** Click and drag on the result clip to draw a box around a range of colours. You can select an area of the image that is predominantly black, white, or contains a wide spectrum of colours. To match the overall saturation of an image, select a larger area of the image.
The blue indicator on the Match button is enabled, indicating that you need to select a destination sample.
- 5** If necessary, position the split bar to show more of the reference image.
- 6** Click Match.
The following message appears in the message bar: "MATCHING: Select an area to match to."
- 7** Click and drag to draw a box around a range of colours in the reference clip. You should match whites with whites, blacks with blacks, or select a broad range of colours on both images to match saturation. Trying to match completely different colours will produce unpredictable results.
The range in the result clip is matched to the range in the reference clip.
- 8** Repeat these steps as often as necessary to obtain the best possible match between colours. You can use Match repeatedly to make your colour match more precise.
- 9** To refine the result, use other controls in the Basics menu (such as the Saturation field), and then reuse Match.

To clear a Match operation:

- 1** Click the Undo box.

To cancel a Match operation in progress:

- 1 If you begin using Match and want to cancel the matching process, adjust any value using the trackballs or fields.
The blue indicator on the Match button will be disabled, indicating that the matching process has been cancelled.

Performing Hue Shifts

You can use the Hue field in the Basics menu to perform hue shifts on the entire image or a range in the image defined by a selective's matte. Perform hue shifts when you want to change the colour of an object or create other artistic effects. Hue shifts do not affect the luma.

You can also perform hue shifts when you want to suppress colour spill. See [Removing Colour Spill](#) on page 1529.

To perform a hue shift:

- 1 If necessary, create a matte for the range of colour you want to change. See [Selecting Colour Ranges for Colour Correction](#) on page 1502.
- 2 Click Basics to display the Basics menu.
If you are using a selective, the Selective View box should display Result when you display the Basics menu.
- 3 Sample the image to see the hue shift in the 2D luma vectorscope. Enable Plot and then sample the colour range in the image you want to hue shift.
A red line also appears in the 2D luma histogram and the sample is outlined in the 2D or 3D vectorscope.
- 4 Drag the Hue field while monitoring the 2D or 3D vectorscope and the image.
The selected colour content (or entire image) shifts through the colour range.
- 5 If necessary, you can change the saturation of the hue by dragging the Saturation field—drag right to increase saturation or left to decrease it.
The selected colour range moves towards the perimeter or centre of the 2D luma histogram.

Creating Colour Casts

You can use the Midtones trackball to create a colour cast that affects the chroma in the entire image without affecting the luma. Create a colour cast when you want to emphasize a colour range to create an artistic effect or when you want to refine an existing cast. For example, create or refine a bluish cast to convey a cooler atmosphere.

NOTE Before you create a colour cast, you should correct colour imbalances in the image or clip. See [Correcting Colour Imbalances](#) on page 1510.

To create a colour cast:

- 1 Click Basics.

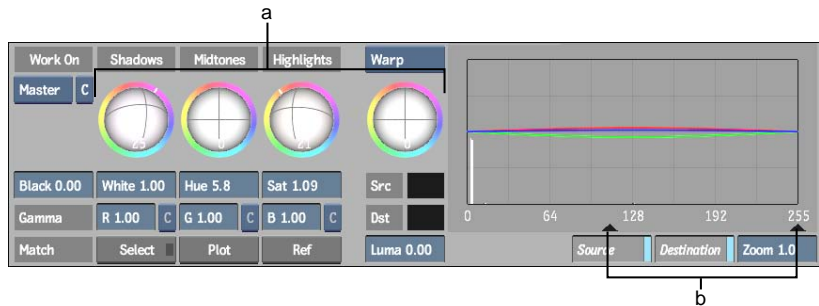

(a) Trackballs (b) Midtones triangles

TIP You can determine the colour of an existing cast by dragging right in the Saturation field to temporarily increase the saturation while monitoring the sample in the 2D vectorscope. Click Undo once you determine the colour of the cast.

- 2 To add a colour cast to the entire image, drag the midtones triangles so that they span the entire luma range.
- 3 While viewing a vectorscope and the image, drag the Midtones trackball towards the colour you want to increase in the clip or image. For example, to add more yellow to the image, drag the Midtones trackball towards yellow.

In the 2D or 3D vectorscope, the colours update to reflect your changes. In the image window, the colour in your clip changes according to the direction the trackball is being dragged.

NOTE When you drag the Midtones trackball, the RGB curves in the 2D luma histogram also reflect the changes you make.

- 4 To increase a range of colour in the highlights or shadows of the image, drag the Highlights or Shadows trackball.
- 5 To increase or decrease the saturation of the cast, drag the Saturation field—drag right to increase saturation and left to decrease it.

TIP You can make slight modifications to the hue of the cast using the Hue field.

Readjusting Colour After a Colour Correction

When colour correcting clips, colours that you do not want to alter may be modified in the colour correction process. Use the Warp trackball in the Basics menu to readjust a specific range of colour.

You can also adjust the luminance of the selected colour using the Luma field.

To readjust colours after a colour correction:

- 1 Click Basics.

The Basics menu appears.

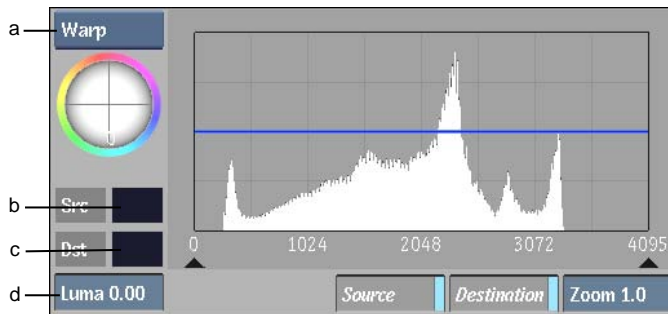

(a) Trackball option box (b) Source Colour pot (c) Destination Colour pot (d) Luma field

- 2 Select Warp from the Trackball option box.
- 3 Click Pick and then sample a colour in the clip you want to modify.

The colour you select is outlined in white in the 2D or 3D vectorscope. A cyan bar representing the colour appears in the 2D luma histogram. The Src Colour pot displays the colour.

- 4 Click the Src Colour pot to set the source colour.
The Dst (destination) Colour pot is updated to match the source colour.
 - 5 Move the Warp trackball towards the destination colour.
The Dst Colour pot dynamically updates to reflect your changes. When you release the mouse, the Src Colour pot is updated to match the destination colour. In the 2D or 3D vectorscope, the selected colour moves to reflect the changes you are making to the image.
-
- NOTE** To make the trackballs respond to changes in pressure, use the Pointer preferences in the Preferences menu. See [Pointer Preferences](#) on page 830.
-
- 6 To adjust the luminance of the destination colour, adjust the Luma field.
When you adjust the luma of the destination colour, the entire luma content of the image is adjusted around the selection. The selected luma value changes the most.
The Dst Colour pot dynamically updates to reflect your changes. When you release the mouse, the Src Colour pot is updated to match the destination colour. In the 2D luma histogram, the cyan bar moves to reflect the changes you are making to the luma content.
 - 7 Release the trackball or click the Luma field.
The Src Colour pot is set to the Dst box colour.

Removing Colour Spill

When you key clips in the Modular Keyer or Keyer, there can be colour spill. You can refine the key by suppressing colour spill in the Colour Warper. Use the Saturate and Suppress trackballs in the Basics menu. Use the Suppress trackball to suppress the colour spill and the Saturate trackball to correct any unwanted colour suppression. When you use these trackballs to modify colour in the image or clip, a range of colour is affected.

If you are using the Colour Warper in conjunction with the Keyer, you should connect the front image or clip to the Colour Warper node and then connect the Colour Warper node to the Keyer node in the Batch schematic. In the Modular Keyer, place the Colour Warper node in the CBlend pipe.

To remove a colour spill:

- 1 Click Basics to display the Basics menu.
- 2 Select Suppress from the Trackball option box.

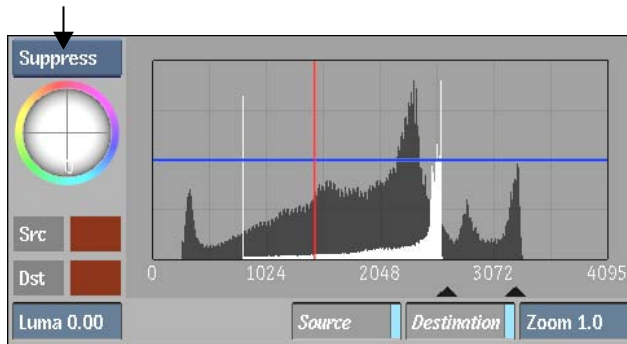

NOTE To make the trackballs respond to changes in pressure, use the Pointer preferences in the Preferences menu. See [Pointer Preferences](#) on page 830.

- 3 Move the Suppress trackball towards the colour that you want to suppress. For example, to remove a blue background, move the trackball so that the blue colours appear in the centre of the 2D vectorscope.

NOTE The colour you are suppressing appears in the middle of the 2D vectorscope at full suppression.

By comparing the Result clip and the CurFront clip, you may notice some unwanted colour suppression to the colour that is opposite (on the colour wheel) the one you just suppressed. You can fix such suppression with the Saturate trackball.

- 4 Select Saturate from the Trackball option box.

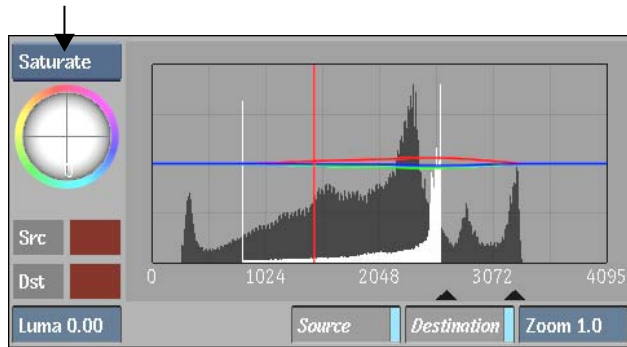

- 5 Move the Saturate trackball towards the colour that you want to saturate. The colour that you are saturating moves closer to the edge of the 2D vectorscope.
- 6 It may be necessary to adjust colours in the image using the Suppress and Saturate trackballs several times to achieve suitable results. Continue adjusting the trackballs until you are satisfied with the result.

Creating Subsetups

Subsetups are Colour Warper setups selected at a specific moment at a specific frame. Subsetups are for the current frame only and do not include entire animations. You can select up to ten subsetups and compare colour corrections in other subsetups. You can save and load a group of subsetups.

NOTE The group of subsetups loaded affects all Colour Warper nodes in the current setup since subsetups are shared between Colour Warper nodes. Ten subsetups (A-J) constitute a group.

Use the Subsetups menu to:

- Selectively store intermediate setups.
- Compare any subsetup to the current setup.
- Share subsetups between Colour Warper nodes.
- Save and load a group of subsetups.

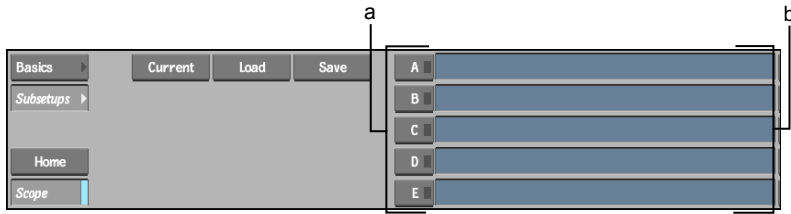

(a) Subsetup buttons (b) Subsetup fields

Storing and Retrieving Subsetup

You can store and retrieve subsetup using the Subsetup buttons.

To store and retrieve the current setup:

- 1 Press and hold one of the subsetup buttons until a message appears indicating “Storing subsetup <subsetup letter>” and release.
The LED indicator shows that the subsetup is stored. All active subsetup have a LED indicator. If you have not stored anything into a subsetup, the active light of the button will be off.
- 2 Use the setup at another frame or in another node by pressing the corresponding Subsetup button.

Naming Subsetup

You can name your subsetup. This allows you to store setups and later compare them to your current setup, or to apply the same correction to different frames in a clip.

To name a subsetup:

- 1 Click in a subsetup field, type in a name or description, and press **Enter** to store the setup.

Replacing Subsetup

You can replace or override a setup.

To replace an existing setup:

- 1 Click and hold a subsetup button to overwrite and replace an existing subsetup. A keyframe is set and the new subsetup is saved.

Comparing Subsetups

The current setup is accessed with the Current button and contains the most recently committed setup. Compare any of your subsetups to each other or to the contents of the current setup.

To commit the contents of the current setup:

- 1 Perform an operation such as advancing a frame or changing a value in the Basics menu. Your present settings will be displayed the next time you click Current.

To compare a subsetup:

- 1 Click a Subsetup button of the subsetup you want to compare.
- 2 Click Current to view the current result.

Saving and Loading Subsetups

Use the Save button in the Subsetups menu to save a group of subsetups. Then use the Load button in a later session to reload the same group of subsetups.

To save a group of subsetups:

- 1 In the Subsetups menu, click Save.
The file browser appears.
- 2 Browse to a different directory path if necessary and then type a name in the Name field.
- 3 Click Save.
The group of subsetups is saved in the specified directory.

To load a group of subsetups:

- 1 In the Subsetups menu, click Load.

The file browser appears.

- 2 Browse to the appropriate path and select the name of the group of subsetups.

The group of subsetups is loaded.

Topics in this chapter:

- [About Filters](#) on page 1535
- [Accessing the Filter Menu](#) on page 1535
- [Applying a Filter to a Clip](#) on page 1536
- [Filter Library](#) on page 1537
- [Customizing Filters](#) on page 1538

About Filters

You can use the default filters or create customized filters. Any filter that you create can be saved in the filter library and later loaded in another work session. You can also combine filters to produce complex effects such as pixel turbulence.

Accessing the Filter Menu

Use the Filter menu to apply a filter across each frame in the source clip.

NOTE To apply a filter to selected areas of an image, use the Paint module. See [Using Filters and Special Effects Media](#) on page 2437.

To access the Filter menu:

- 1 In the Main menu, click Processing and then Filter.
- 2 Select a source clip.
- 3 Select a destination.

The Filter menu appears.

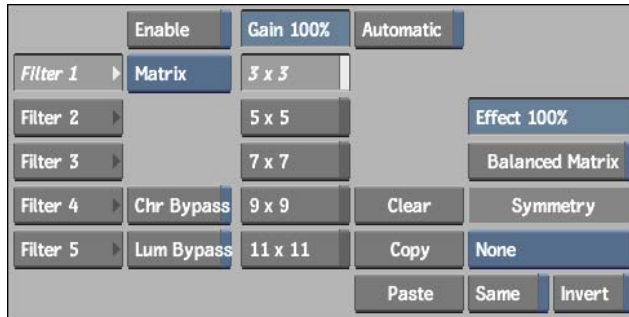

Applying a Filter to a Clip

When you apply a filter to a clip, you can control the level of filtering applied. Decreasing the value reduces the filtering effect, while increasing the value magnifies the filtering effect. You select a filter from the filter library.

To apply a filter to a clip:

- 1 In the Filter menu, click Load to open the filter library.
- 2 Select the filter you want to use from the filter library that appears.
The Filter menu returns. The name of the selected filter appears in the Filter Title field.
- 3 Select Result from the View box to preview the effect of the filter on the source clip.

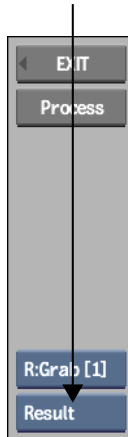

NOTE Select Front to view the source clip.

- Adjust the value in the Effect field to get the level of filtering you require.

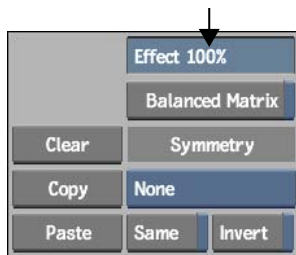

- Click Process to apply the filter to the clip.

Filter Library

The supplied filters are stored in the filter library. Additional filters you create can also be stored there. To open the filter library, click Load or Save in the Filter menu.

The following table describes some of the filters available in the filter library.

Use:	To:
Softening filters	Cause the image to appear less focused by decreasing the contrast between adjacent pixels.

Use:	To:
Sharpening filters	Provide light, medium, and heavy levels of image sharpening. These filters improve the clarity and focus of an image by increasing the contrast between adjacent pixels.
Outline filters	Outline areas where sudden colour changes occur in an image.
Saturate and Desaturate filters	Decrease or increase the amount of grey in an image. Saturation refers to the colour purity, or the amount of grey in the image. Less grey creates a more saturated image.
Scanner Correct filters	Remove undesirable effects encountered with scanned images.
Fragmentation and Reticulation filters	Displace pixels in the source image.
Negative filters	Produce a negative of the source image.

Customizing Filters

Although the filter library contains a number of special effects filters, you may need custom filters for specialized applications.

When a filter is applied to an image, the colour value of each pixel in the image is evaluated individually and is modified in one of two ways:

- A matrix-based spatial filter modifies each pixel according to calculations performed on its surrounding pixels.
- A procedural filter modifies each pixel in a predefined way.

A filter is composed of up to five matrix or procedural image operations. These operations are performed in sequence so the output from one operation becomes the input to the next. When these operations are combined, they are called *filter elements* to distinguish them from the final composite filter. Matrix and procedural filter elements can be combined within a single filter.

Using Matrix Filter Elements

A matrix specifies the relative influence of each pixel's colour value in the filter calculation. Each matrix consists of a grid of fields. The field at the centre

of the grid represents the pixel currently being evaluated (the current pixel). The remaining fields represent the pixels surrounding the current pixel. The value you set in each field determines the relative influence of the corresponding pixel in the filter calculations. A pixel with a higher value is more influential in the calculations than a pixel with a lower value.

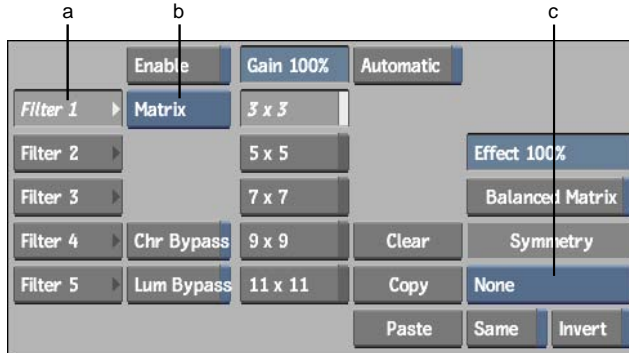

(a) Filter Elements (b) Filter Type (c) Symmetry Type

To customize a filter using matrix elements:

- 1 Select the current filter element: Filter 1, Filter 2, Filter 3, Filter 4, or Filter 5.
You can use up to five filter elements in a single custom filter.
- 2 Select Matrix from the Filter Type box and select the matrix dimensions.



(a) Matrix dimension buttons

The 3 x 3 button opens a matrix of three rows by three columns; the 5 x 5 button opens a matrix of five rows by five columns, and so on.

- 3 Click Enable to select the filter element.

- 4 Enter a numeric value in the matrix fields for all the pixels you want to consider. For information on balancing the matrix, see [Using the Balanced Matrix Option](#) on page 1541.

The matrix fields are numeric. Permissible values range from -255 to +255 in 8-bit mode, and from -4095 to +4095 in 12-bit mode.

NOTE Click Clear to reset all the values in the matrix.

- 5 To bypass the chrominance (hue and saturation) channels or the luminance (brightness) channel of an image, enable Chr Bypass or Lum Bypass.
- 6 If required, set the Symmetry options. See [Using Symmetry Options](#) on page 1541.
- 7 Enable Automatic to preserve the average luminance of the clip. To boost or reduce the colours in the image, adjust the value in the Gain field. Values less than 100% subdue the colours and values greater than 100% boost the colours.

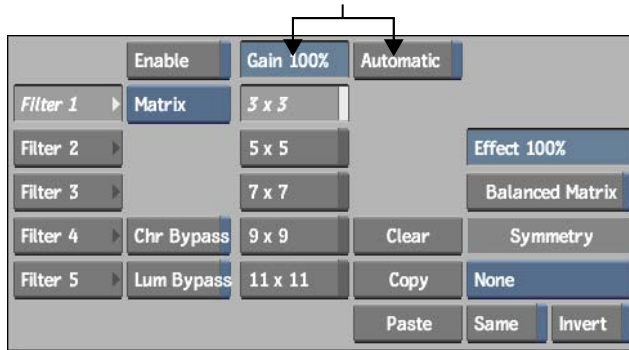

- 8 Repeat these steps for each element you want to include in the custom filter.
- 9 Select Result view to preview the effect of the new filter on the source clip. You can continue to adjust the filter elements as required.
- 10 Save the new filter in the filter library. See [Saving Custom Filters](#) on page 1544.
- 11 To apply the new filter to the clip, click Process.

Using the Balanced Matrix Option

You can use the Balanced Matrix option to create various custom effects. Enable Balanced Matrix and then enter a value in a matrix field. An algorithm divides the number you entered by the total number of fields and then subtracts the result from each value in the matrix.

NOTE Generally, using this option also prevents colours in the clip from becoming too bright or too dark.

Using Symmetry Options

When changing values in the matrix, you can use the Symmetry options to change multiple elements in various symmetrical arrangements to produce different effects.

To use symmetry:

- 1 Set up a matrix filter element using the procedure in the previous section.
- 2 Select an option from the Symmetry Type box.

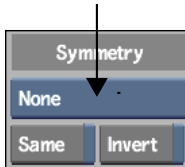

Select:	To:
None	Change each element in the matrix individually without using the symmetry principle.
Horizontal	Change two horizontally symmetrical elements.
Vertical	Change two vertically symmetrical elements.
Diagonal Pos	Change two diagonally symmetrical elements in the positive direction (lower left to upper right).
Diagonal Neg	Change two diagonally symmetrical elements in the negative direction (lower right to upper left).
All	Change four horizontally and vertically symmetrical elements.

- 3 Select the value shifting method.

Enable:	To:
Same	Change all symmetrical elements to the same value.
Invert	Change the symmetrical element by the same amount but in the opposite direction (either positive or negative) of the input value.

NOTE You cannot use Invert in Symmetry All mode.

Copying and Pasting Filter Settings

Use the Copy and Paste commands in the Filter Matrix menu to copy a setup from one filter and apply it to a custom filter. The Copy command copies the displayed matrix as well as the status of the Chr Bypass and Lum Bypass buttons.

To copy and paste filter settings:

- 1 Load the filter you want to modify.
- 2 Display the matrix setup you want to copy and click Copy.
- 3 Select the filter element to which you want to paste the settings: Filter 1, Filter 2, Filter 3, Filter 4, or Filter 5.
- 4 Select Matrix from the Filter Type box.
- 5 Click Paste.

The setup you copied is pasted into the current filter element.

Using Procedural Filters

You can combine up to five matrix or procedural filter elements into a custom filter. Procedural filters use a predefined procedure instead of matrix calculations to alter the image.

To customize a filter using a procedural filter:

- 1 Select the filter element: Filter 1, Filter 2, Filter 3, Filter 4, or Filter 5.
- 2 Select Procedural from the Filter Type box.

The Procedural Filter menu appears.

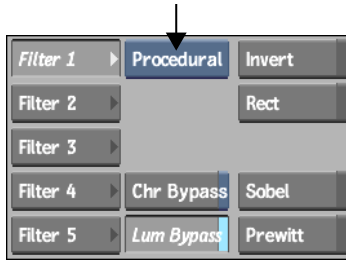

- 3 Select the procedural filter you want to use.

Enable:	To:
Invert	Invert the image.
Rect	Blur the image. Use the Height and Width fields that appear to adjust the direction and intensity of the blur.
Sobel	Use an edge-detection filter. Select the direction in which the filter is applied from the field that appears in the menu. The options are DiagRight (diagonal right), DiagLeft (diagonal left), and Horiz/Vert (horizontal/vertical).
Prewitt	Use an edge-detection filter. As with the Sobel filter, you can select the direction in which the filter is applied.

- 4 Click Enable to select the filter element.
- 5 To bypass the chrominance (hue and saturation) channels or the luminance (brightness) channel of an image, enable Chr Bypass or Lum Bypass.
- 6 Repeat these steps for each element you want to include in the custom filter.
- 7 Select Result view to preview the effect of the new filter on the source clip. You can continue to adjust the filter elements as required.
- 8 Save the new filter in the filter library. See [Saving Custom Filters](#) on page 1544.

- 9 To apply the new filter to the clip, click Process in the Filter menu.



The original image

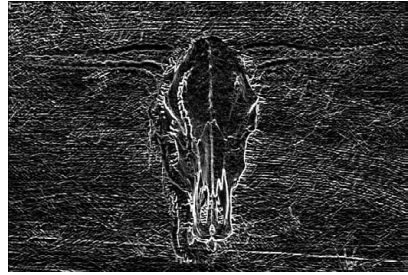

After applying the Sobel procedural filter

Saving Custom Filters

You can save custom filters in the filter library.

To save your custom filter:

- 1 Type the name of the new filter and press **Enter**.
- 2 To apply the new filter to the clip, click Process.

Topics in this chapter:

- [About the Keyer](#) on page 1545
- [Accessing the Keyer](#) on page 1546
- [Creating and Refining a Key](#) on page 1548
- [Creating a Key by Extracting a Single Colour](#) on page 1560
- [Creating a Key by Extracting a Range of Colours](#) on page 1562
- [Creating a Key by Setting the Luminance](#) on page 1568
- [Adjusting the Luminance of the Key](#) on page 1569
- [Refining the Key](#) on page 1576
- [Colour Correcting the Key](#) on page 1592
- [Animating Your Key](#) on page 1594
- [Additional Keying Techniques](#) on page 1595
- [Resetting Keys](#) on page 1597
- [Processing Clips](#) on page 1598

About the Keyer

Use the Keyer to make parts of an image transparent by selecting and isolating regions of colour. This process creates an alpha-channel matte, which is then used to composite the image over a new background.

You can create composites by defining transparent regions in a foreground clip, based on a specific range of colour, to reveal a background clip. This keying process is usually performed on footage with a subject in front of a blue or green screen. When you key out a colour, you generate a *matte*: a black and white template indicating which parts of the image are transparent (black), and which are opaque (white). Using techniques such as softening the edge of mattes, you can refine the results to create realistic composites.

You can also use garbage masks to key out undesired elements in an image. To learn about using garbage masks when pulling a key, see [Garbage Masks](#) on page 1707.

Accessing the Keyer

You load three clips into the Keyer to create a composite: a front clip, a back clip, and a key-in clip. The key-in clip, which is usually the same as the front clip, is used to create the matte for the front clip.

To access the Keyer:

- 1 In the Main menu, click Effects, and then Keyer.
- 2 Select the front, back, and key-in clips. Make sure the front, back, and matte clips are the same resolution. If not, resize them. See [Accessing Resize and Resize Settings](#) on page 664.

TIP Use the S option on the Keyer button on the Desktop to automatically load the same clips used in the previous session. Click the S option, and then select the destination.

- 3 Select the destination.
The Keyer appears.

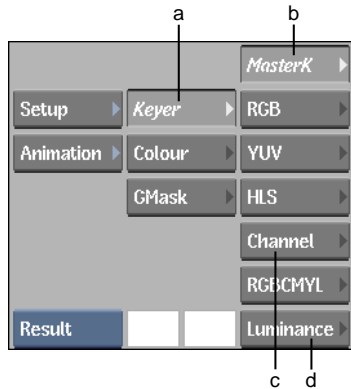

(a) Keyer button (b) Master Keyer button (c) Channel button (d) Luminance button

Storing Colours in Reference Colour Pots

You can use the Reference colour pots, accessible anywhere in the Keyer, to sample colours. These do not affect any parameter in the key, but are convenient to store colours as you work.

For example, use colour pickers from the Reference colour pots to pick flesh tones from one clip. Then in another clip, use the colour pickers from a Sample colour pot in the Master Keyer to pick the stored colours from the Reference colour pots to key out an actor from a clip.

To store colours for reference:

- 1 Click a Reference colour pot.



- 2 Use the colour picker that appears to sample a colour from a clip. See [Picking Colours](#) on page 71.

Creating and Refining a Key

Use the Master Keyer method to create a complete key—extract colours to generate a matte and then refine the result—using only the Master Keyer menu. The Master Keyer uses an algorithm that quickly isolates a colour and is very good for chroma keying.

With the Master Keyer, you can refine the key by gesturally modifying the matte, removing colour spill, blending edges, applying patches, and removing grain.

To access the Master Keyer menu:

- 1 In the Keyer, click Keyer, and then click MasterK.

The Master Keyer menu appears.



(a) Primary Sample colour pot (b) Secondary Sample colour pot (c) Edge Balance trackball (d) Sampling box (e) Reset button

The following procedure is a recommended workflow for keying a clip with the Master Keyer. You may not need to complete all the procedures. You may also revisit procedures as you develop the key.

To create a complete key:

- 1 Generate and refine a matte using the Matte controls.
- 2 Remove any colour spill.
- 3 Improve the blend between the front and back clips.

- 4 If the image is grainy, apply the Degrain algorithm.
- 5 Create any necessary patches to remove unwanted grey areas from the matte.

Generating Mattes

Use the Matte controls to generate and refine a matte for your chroma key.

To generate and refine a matte:

- 1 In the Master Keyer menu, select Matte from the Sampling box (or press **M**).

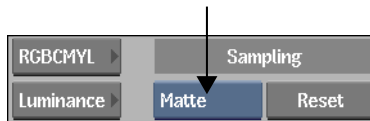

- 2 Set the view to Result or Matte view.

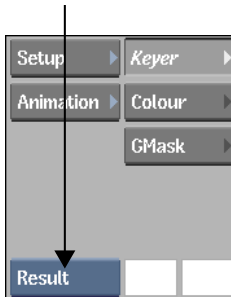

- 3 Click the Primary Sample colour pot and then sample the image. Click the image to sample a single pixel.
The Auto CC button is enabled and the initial pure colour value for the key is set.
- 4 Click the Secondary Sample colour pot and then sample the image. Sample an area where you do not want any softness in the matte.
- 5 Drag in the Mix field to adjust the mix between the primary and secondary sample. Drag right to include more of the secondary sample or left to include less.



TIP You can adjust the mix at any time as you develop the key.

- 6 Gesturally refine the matte. In the image window, click an area of the matte that you want to refine—only those parameters that pertain to the area you click appear. Parameters are displayed in order of importance, from top to bottom (those that are brightest and at the top have the greatest effect on the image). You can then modify a parameter by dragging its highlighted slider.

- To add softness, drag a slider to the right.
- To remove softness, drag a slider to the left.

The red indicator shows the original value and the yellow indicator shows the current value.

- 7 To modify more than one parameter, move the mouse between the parameters to highlight a parameter, or drag the pen vertically. When you highlight the parameter you want to adjust, drag the slider.

TIP If you do not like the result, you can click Undo to reset parameters directly after you complete the operation. There is only one level of undo in the Keyer menu.

- 8 When you are finished modifying the displayed parameters, click another area of the image without highlighting a parameter to hide them. Alternatively, you can press any key, such as **spacebar** or **Esc**. The parameters are no longer displayed.
- 9 Repeat steps 6 to 8 in other parts of the matte to further refine it. Only the parameters that apply to the problem area will appear.
- 10 To scroll through the image and display the pertinent parameters, **Alt**-drag the image without clicking it. The parameters update as you drag. You can then modify the displayed parameters by clicking the image and dragging the highlighted slider.

NOTE To reset Matte parameters, click the Reset button, next to the sampling box. All matte parameter are reset, except the Mix field and the key colour.

Removing Colour Spill

After you create and refine a matte for the key, you can remove colour spill by gesturally modifying the Spill parameters. You can also remove colour spill by using the Spill controls in the Range or Colour menu. For instructions on using Spill controls, see [Adjusting Spill Controls](#) on page 1584.

NOTE To remove colour spill using the Master Keyer menu, the Auto CC button must be enabled.

To gesturally remove colour spill:

- 1 In the Master Keyer menu, select Spill from the Sampling box (or press S).

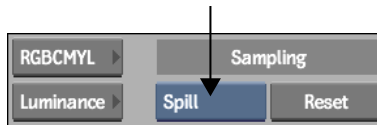

- 2 Set the view to Result view.

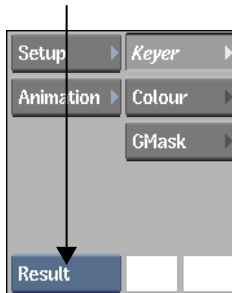

- 3 Enable Auto CC to apply the Spill settings to the front clip.



- Remove any colour spill. Click anywhere in the image window, and then modify the parameters that appear by dragging the sliders—you do not need to click a specific area.

Drag:	To:
Range	Set the range for the removal of colour spill along the edges of the key. Drag right to soften the edge and remove colour spill further into the key. Drag left to harden, or create a thinner, edge.
Hue	Modify and suppress colours that are adjacent to the primary sample.

The red indicator shows the original value and the yellow indicator shows the current value. The values also appear in the Spill fields. The original values should be good, so make small adjustments only.

- To modify both parameters, move the mouse between them to highlight a parameter, or drag the pen vertically. When you highlight the parameter you want to adjust, drag the slider.

If you do not like the result, you can click Undo to reset parameters directly after you complete an operation. There is only one level of undo in the Keyer menu.

- When you are finished modifying the displayed parameters, click another area of the image without highlighting a parameter to hide them. Alternatively, you can press any key, such as **spacebar** or **Esc**. The parameters are no longer displayed.

NOTE To reset Spill parameters, click the Reset button, next to the sampling box. Alternatively, you can reset the Spill parameters, Blend parameters, and the Edge Balance trackball by clicking Reset, located left of the Edge Balance trackball.

Blending Front and Back Clips

After you remove colour spill, you can use the Blend parameters to gesturally modify the luminance at the edge of the key so that it blends with the luminance in the background clip. For example, when the front clip is darker than the back clip, you can use the Blend parameters to lighten the edge of the key. You can also use the Blend controls in the Keyer or Colour menu. For instructions on using Blend controls, see [Blending the Front and Back Clip](#) on page 1590.

When you blend front and back clips, you can add a cast to the edge of the key and further integrate the clips.

NOTE To blend front and back clips in the Master Keyer menu, the Auto CC button must be enabled.

To blend the front and back clips:

- 1 In the Master Keyer menu, select Blend from the Sampling box (or press **B**).

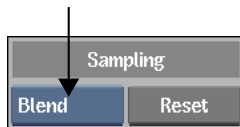

- 2 Set the view to Result view.

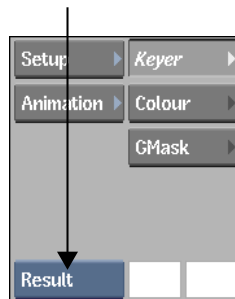

- 3 Enable Auto CC to apply the Spill settings to the front clip.

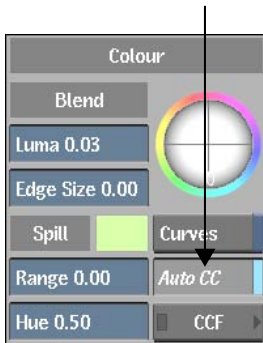

- 4 Blend the front and back clip. Click anywhere in the image window, and then modify the parameters that appear by dragging the sliders—you do not need to click a specific area.

Drag:	To:
Luma	Darken or lighten the edge of the key. Luma only affects the luma of the edge.
Edge Size	Set the range for the blend. Drag right to soften the edge and blend further into the key. Drag left to harden, or create a thinner, edge. Edge Size affects both the Luma field and the Edge Balance trackball.

TIP To drag faster, apply more pressure with the pen, or right-click the mouse while you drag.

The red indicator shows the original value and the yellow indicator shows the current value. The values also appear in the Blend fields.

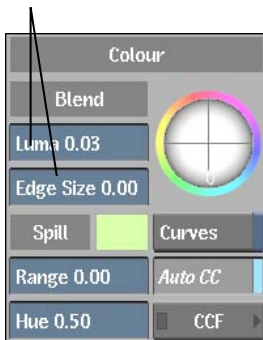

- 5 To modify both parameters, move the mouse between them to highlight a parameter, or drag the pen vertically. When you highlight the parameter you want to adjust, drag the slider.

TIP If you do not like the result, you can click Undo to reset parameters directly after you complete an operation. There is only one level of undo in the Keyer menu.

- 6 When you are finished modifying the displayed parameters, click another area of the image without highlighting a parameter to hide them. Alternatively, you can press any key, such as **spacebar** or **Esc**. The parameters are no longer displayed.
- 7 To add a cast to the edge of the key and improve the overall look by matching the edge with a colour cast in the back clip, drag the Edge Balance trackball toward the colour you want to add. The trackball only affects the chroma of the edge.

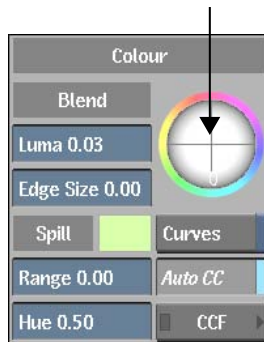

NOTE To reset Blend parameters, click the Reset button, next to the sampling box. All blend parameters are reset, except the Edge Balance trackball. **Ctrl-click** the Edge Balance trackball to reset it. Alternatively, you can reset the Spill parameters, Blend parameters, and the Edge Balance trackball by clicking Reset, located left of the Edge Balance trackball.

Removing Grain

Graininess can make it difficult to pull a clean and effective key. Use the Degrain tools in the Master Keyer to remove grain from clips.

The same Degrain tools are also available in the Keyer's Setup menu. If you set the Degrain parameters in the Master Keyer, they affect only the Master Keyer. If you set the Degrain parameters in the Keyer's Setup menu, they affect all the Keyer's ranges, including the Master Keyer. See [Blurring Grainy Clips](#) on page 1580.

NOTE Degrain parameters are animatable. Degrain samples are also animatable and appear in the Channel Editor as the Degrain_Matrix channel, located in the Key_Degrain folder. See [Creating Animations](#) on page 1971.

To remove grain:

- 1 In the Master Keyer menu, select Degrain from the Sampling box (or press 4).

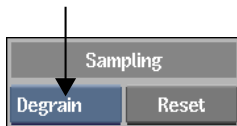

- 2 Set the view to Result view.

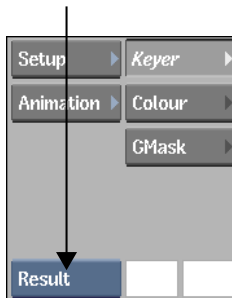

- 3 Sample a grainy area of the image. To sample a single pixel, click the image. To sample an area of the image, **Ctrl**-drag a selection box.

The Degrain button is enabled and the algorithm is applied to the image—grain is removed from the image.

NOTE The Degrain button is either enabled or disabled for the entire clip—you cannot turn it on and off for different frames in the clip.

- 4 Drag in the Degrain fields to modify the grain size and restore edge sharpness.



(a) Size field (b) Edges field

Drag: **To:**

Size Estimate the size of the grain in the image.

Edges De-sharpen the edge of the image. By default, Degrain sharpens the edges. Use the Edges field to restore the natural look of the edges in the image.

- 5 If you are not satisfied with the result, you can start over with a new sample, and then adjust the Degrain fields. To resample an area of the image, **Ctrl+Alt**-drag the image.

The sample is outlined in green, indicating that you are resampling the image.

NOTE You can also reset Degrain parameters. To reset Degrain parameters, click the Reset button, next to the sampling box.

- 6 If resampling the image and adjusting the Degrain fields does not sufficiently remove grain, enable More to increase the overall effect of Degrain.

NOTE The More button is either enabled or disabled for the entire clip—you cannot turn it on and off for different frames in the clip. When you enable More, processing speed slows down.

Removing Unwanted Greys

If you have unwanted grey areas in the matte, you can use up to three patches to isolate a range of colours to be included in, or excluded from, the key.

NOTE Patch parameters are animatable. Patch samples are also animatable and appear in the Channel Editor as a Matrix channel, located in the Patch folder.

To remove unwanted greys:

- 1 In the Master Keyer menu, select Patch1, Patch2, or Patch3 from the Sampling box (or press **1**, **2**, or **3**).

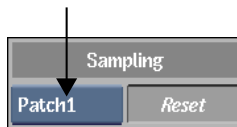

- 2 Set the view to Matte view or Result view.

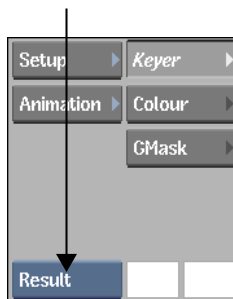

- 3 Sample the image where you want to apply the patch. To sample a single pixel, click the image. To sample an area of the image, **Ctrl**-drag a selection box.

When you **Ctrl**-drag to sample, the sample is outlined in red. In the Master Keyer menu, the Patch button is enabled and the appropriate patch appears in the Patch box and is applied to the image.

NOTE A Patch button is either enabled or disabled for the entire clip—you cannot turn it on and off for different frames in the clip.

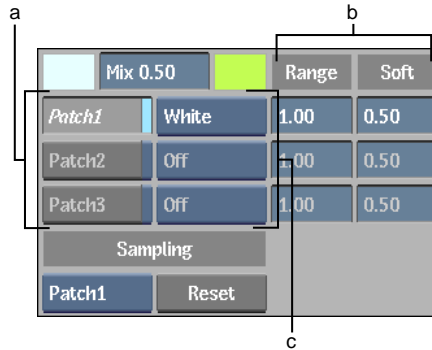

(a) Patch buttons (b) Patch controls (c) Patch boxes

Selected patch:	Is applied to:
Black	Areas of the image to be included in the black part of the matte.
White	Areas of the image to be included in the white part of the matte.
Edge Analysis	Areas of the image that are along the edge of the key. Edge Analysis is useful when there is a specific edge you want to erode but cannot do so with the Matte parameters. You can then increase or decrease the softness of this patch using the Soft field.

- To add more colour to the patch, resample the image.
- To use the same patch but start with a new sample, **Ctrl+Alt**-drag the image.
The sample is outlined in green, indicating that you are resampling the current patch.

- To manually select a patch type, select it from the Patch box.

NOTE If you want to reset the patch so that you can automatically select the patch type, you must disable the patch and set the patch type to Off. You can then resample an area in the image and generate a patch type.

- To improve the patch, use the Patch controls.

Drag:	To:
Range	Increase or decrease the colour range that is included in the patch.

Drag:	To:
Soft	Soften the edge.

NOTE To reset Patch parameters, click the Reset button, next to the sampling box.

Creating a Key by Extracting a Single Colour

You can extract one of the three primary colours (red, green, or blue), or a custom colour from the key-in clip. This method is useful for clips containing transparencies such as glass or smoke.

Extracting a Primary Colour

Extract one of the three primary colours from the key-in clip when you have a front clip shot in front of a blue, red, or green screen.

To create a key by extracting a primary colour:

- 1 In the Keyer, do one of the following:
 - Click Keyer to show the Keyer menu.
 - Click Colour to show the Colour menu.

- 2 Click Channel.

The Channel controls appear.

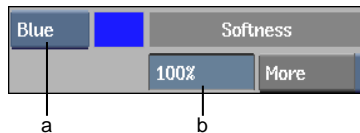

(a) Channel Mode box (b) Softness field

- 3 Select one of the primary colour options (Red, Green, Blue) from the Channel Mode box.
- 4 Enable More to enhance the keying effect.

The More option extends the range of the colour to be extracted from the key-in clip.

- 5 Increase or decrease the softness for the key using the Softness field.
The softness value determines how much of the key-in clip is partially transparent in the matte. Softness creates a smoother transition between the front and back clips in the composite clip.
- 6 Click Result to see the result of your key.

Extracting a Custom Colour

Use the Custom colour channel option to select the colour to be extracted from the key-in clip. This option can give good results when keying transparencies, particularly by experimenting with the Softness and Colour Spread values.

To create a key by extracting a custom colour:

- 1 In the Keyer, do one of the following:
 - Click Keyer to show the Keyer menu.
 - Click Colour to show the Colour menu.
- 2 Click Channel.

The Channel controls appear.



(a) Channel Mode box (b) Average Colour pot (c) Softness field (d) Colour Spread field

- 3 Select Custom from the Channel Mode box.
- 4 Click the Average Colour pot.
The cursor changes to a colour picker.
- 5 Click the image to select a single colour, or drag the colour picker across a region to obtain the average of the colours encountered by the colour

picker. Try selecting different colours in the background area to get the best result.

TIP To keep shadows, click just outside them. To remove shadows, click inside them.

- 6 Adjust the softness for the key using the Softness field.
Increasing softness raises the level of grey in the matte. Lowering it makes the matte sharper.
- 7 Adjust the colour spread for the key using the Spread field.
Increasing the colour spread value extends the range of colours extracted from the key-in clip.
- 8 Click Result to see the result of your key.

NOTE To improve the key at this point, try adjusting it with the histogram. See [Adjusting the Luminance of the Key](#) on page 1569.

Creating a Key by Extracting a Range of Colours

Another technique for creating a key is to extract a range of colours from the key-in clip. Use this technique for clips where the colour you are extracting contains impurities.

When you build a key by defining a colour range, you can use one of four colour models: RGB, YUV, HLS, or RGBCMYL. Each model interprets the key-in clip differently and gives a slightly different result.

Once you choose a colour model, you set a range of colours to become partially transparent in the key-in clip to soften the transition between the front and back clips. This is called the *softness range*. All pixels in the front clip within the softness range become grey in the matte. The key should have the greatest possible softness value.

After setting the softness range, you set a range of colours to be keyed out in the key-in clip. This is called the *tolerance range*. All pixels in the front clip within the tolerance range become black in the matte. The tolerance range must not be too large or the edge of the composite will be too hard and the subject in the front clip will appear to be pasted into the back clip.

Selecting a Colour Model

There are four colour models you can use.

HLS

In the HLS menu, you set the softness and tolerance ranges using the hue, luminance, and saturation channels.

YUV

In the YUV menu, you set the softness and tolerance ranges using the luma and chroma signals of YUV component video.

RGB

In the RGB menu, you set the softness and tolerance ranges using the red, green, and blue channels.

RGBCMYL

In the RGBCMYL menu, you set the softness and tolerance ranges using the red, green, blue, cyan, magenta, yellow, and luminance channels. This colour model provides subpixel resolution.

Trying Out Different Colour Models

To determine which colour model will give you the best key, try creating a sample matte for each model. Each model operates independently. When you switch from one model to another, the values you set are retained, so you can easily compare the results.

To create a sample matte for each colour:

- 1 In the Keyer, click Keyer.
- 2 Select Key In in the View box to view the key-in clip.



3 Select a colour model.

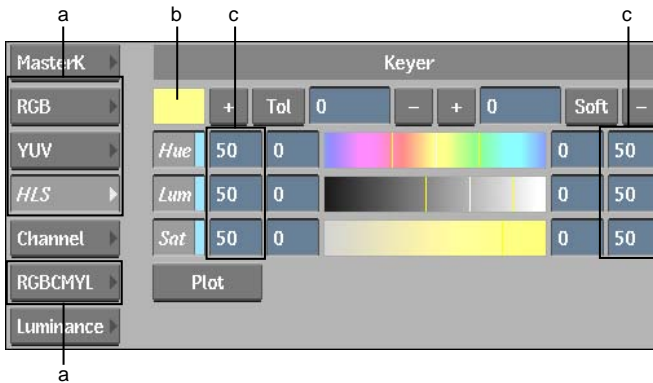

(a) Colour models (b) Average Colour pot (c) Softness values

The softness for each model is set automatically to 50, which helps you to quickly gauge the model that will create the best key for your clip.

4 At frame 1, click the Average Colour pot.

5 Drag the colour picker around the area you want to key out.

The average colour sampled by the colour picker appears in the Average Colour pot. In each channel of the colour model, the channel value of the average colour appears as a white line. All pixels in the key-in clip with the selected colour value are keyed out.

The yellow lines in the colour model channels indicate the limits of the softness range. The pixels in the front clip with colour values at the centre of the range are black (transparent) in the matte. As you move away from the centre, the pixels become more opaque.

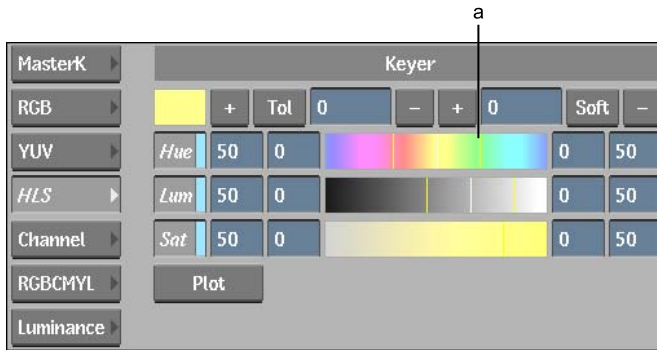

(a) Softness range

- From the View box, select Matte.

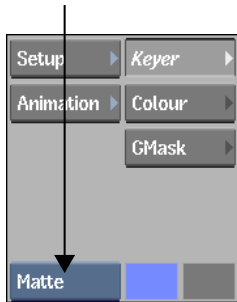

The matte for the selected colour model appears in the image window.

- Repeat this procedure to plot the average colour using the other colour models, and then view each resulting matte to determine which model gives the best result. Once you decide on a colour model, use the tools described in the next sections to refine your matte.

Setting the Softness Range

After you choose a colour model and set the average colour, adjust the softness range. The softness at the edges of the matte increases as you increase the softness range. To set the softness, you can use the colour picker, the numeric fields, or the Master Softness field.

To set the softness using the colour picker:

- 1 Zoom in to see the edges of the matte more clearly.
- 2 Click Softness in the selected colour model menu.
The cursor changes to a colour picker.
- 3 Position the colour picker at the edge of the matte. To increase the softness, click and slowly drag the colour picker toward the centre of the matte. The values within the area you selected are used to adjust the maximum and minimum values for the softness range. The positions of the yellow lines change as you drag the cursor on the image.

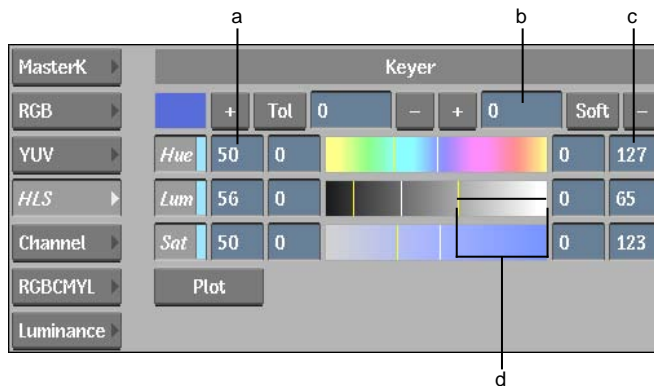

(a) Minimum Softness field (b) Master Softness field (c) Maximum Softness field
(d) Softness range is increased

- 4 To increase or decrease the softness range, click the + or - button beside the Softness button and then click an area of the image.

To set the softness range using the numeric fields:

- 1 Set the minimum value for the softness range using the Minimum Softness field on the left side of the colour bar.
- 2 Set the maximum value for the softness range using the Maximum Softness field on the right side of the colour bar.

To set the softness range using the Master Softness field:

- 1 Set a value in the Master Softness field.

The value is added to the existing softness value of each channel. The Master Softness field is reset to zero after you set the value.

Setting the Tolerance Range

Once you define the softness range, you can set the tolerance range to remove the greys outside the key shape. The maximum and minimum tolerance values define the range of colours to be keyed out in the key-in clip. To set the tolerance, you can use the colour picker, the numeric fields, or the Master Tolerance field.

To set the tolerance range using the colour picker:

- 1 Click Tolerance.

The cursor changes to a colour picker.

- 2 Drag the colour picker around the area of the image that you want to key out.

The colour values that the colour picker samples are used to set the maximum and minimum values for the tolerance range. The white lines define the limits of the tolerance range. All colour values between the white lines are extracted from the key-in clip.

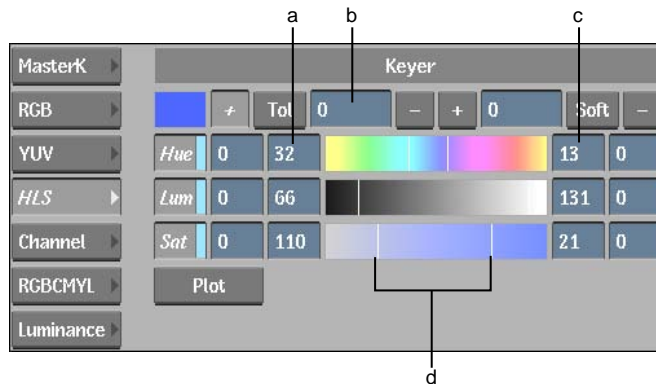

(a) Minimum Tolerance field (b) Master Tolerance field (c) Maximum Tolerance field (d) Tolerance range

- 3 To increase or decrease the tolerance range, click the + or - button beside the Tolerance button.

NOTE An alternative method of setting the tolerance range is to press **Ctrl** and draw a rectangle in the area of the image you want to key out.

To set the tolerance range using the numeric fields:

- 1 Set the minimum value for the tolerance range using the Minimum Tolerance field on the left side of the colour bar.
- 2 Set the maximum value for the tolerance range using the Maximum Tolerance field on the right side of the colour bar.

To set the tolerance range using the Master Tolerance field:

- 1 Set a value in the Master Tolerance field.
The value is added to the existing tolerance value of each channel. The Master Tolerance field is reset to zero after you set the value.

Plotting Colour Values When Adjusting Tolerance or Softness

Display the colour value for any pixel in the key-in clip using the Plot tool. You can then adjust the tolerance or softness range so the pixel falls within one of the ranges. For example, plot pixels at the edges of the matte to check for softness, or plot pixels in the background to check for tolerance.

To plot a pixel's colour values:

- 1 Click Plot (or press **P**).
The cursor changes to a colour picker.
- 2 Select a pixel in the image area.
A red bar appears in each colour gradient showing the colour value of the pixel.

Creating a Key by Setting the Luminance

You can create a key using only the Luminance channel. The softness and tolerance values are expressed as percentages.

This technique is useful for clips with high contrast or filmed against a black background. You can also use the Luminance channel to adjust a matte that has already been rendered. Load the matte as the key-in clip, and then adjust it in the Luminance menu.

NOTE When you load a matte as the key-in clip and open the Luminance menu with default menu values, the resulting Keyer matte is identical to the original matte.

To create a key by setting the luminance:

- 1 In the Keyer, click Keyer, and then click Luminance.

The Luminance controls appear.

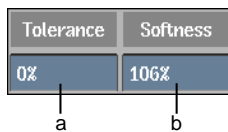

(a) Master Tolerance field (b) Master Softness field

- 2 Set the softness in the Master Softness field.
- 3 Set the tolerance in the Master Tolerance field.

A value of 100 for the tolerance creates an entirely opaque matte.

NOTE You can reset values in Master Softness and Tolerance fields by clicking the Reset button.

Adjusting the Luminance of the Key

After creating a key, you can adjust luminance values to fine-tune the result. The histogram, in the Matte menu, displays the distribution of luminance values within the matte. The horizontal axis of the histogram represents the range of luminance values in the matte and spans from 0 (black) to 255 (white). The vertical axis shows the number of pixels at each luminance value.

Setting the Range of Luminance Values

Use the Input Level controls to set the range of luminance values in the matte. You can darken black areas of the matte or remove grey from white areas of the matte.



(a) Lift and Gain fields

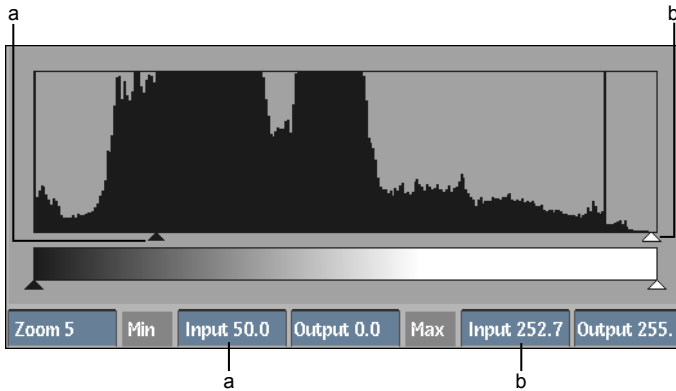

(a) Minimum Input level (b) Maximum Input level

Removing Grey from the Black Areas of the Matte

The Minimum Input level sets the start of the range of luminance values. Pixels with luminance values below the Minimum Input level are mapped to black (0).

You can set the Minimum Input level by dragging the black triangle, or by setting a value in the Minimum Input Level field.



The matte before adjusting the Input levels



The matte after lowering the Minimum Input level

Removing Grey from the White Areas of the Matte

The Maximum Input level sets the end of the range of luminance values. Pixels with luminance values greater than the Maximum Input level are mapped to white (255).

You can set the Maximum Input level by dragging the white triangle, or by setting a value in the Maximum Input Level field.



The matte before adjusting the Input levels



The matte after lowering the Maximum Input level

Remapping Black and White

Use the Output levels to remap the luminance values for black (0) and white (255). You can brighten the dark areas of the matte or darken the white areas.

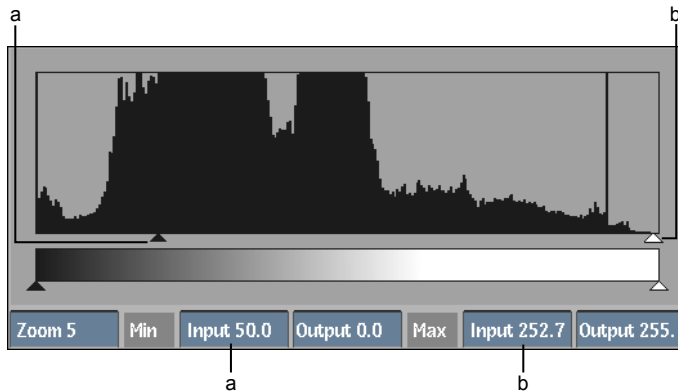

(a) Minimum Output level (b) Maximum Output level

Brightening the Matte

The Minimum Output level sets the luminance value of all black (0) pixels in the matte. Black pixels in the matte are mapped to the luminance value set by the Minimum Output level.

You can set the Minimum Output level by dragging the black triangle, or by setting the value in the Minimum Output Level field.



The matte before adjusting the Output levels



The matte after lowering the Minimum Output level

Darkening the Matte

The Maximum Output level sets the luminance value of all white (255) pixels in the matte. White pixels in the matte are mapped to the luminance value set by the Maximum Output level.

You can set the Maximum Output level by dragging the white triangle or by setting the value in the Maximum Output Level field.



The matte before adjusting the Output levels



The matte after lowering the Maximum Output level

Boosting the Key's Luminance Using Gain and Lift

You can remove grey from the key by increasing the gain and lowering the lift values in the Matte menu. Increase the gain to eliminate the light greys that may be in the white area of the matte, and decrease the lift to eliminate dark greys in the black area of the matte.

NOTE Adjusting these values increases the contrast and may harden the edges of the matte.

Using the Luminance Curves

When you create a matte for the front clip, the Keyer automatically creates a matte for the back clip to specify which part of the back clip is used for the composite. By default, the back matte is the inverse of the front matte.

You can adjust the luminance of the front matte and back matte separately in the Blending menu. For example, increase the luminance of the back matte

so that more of the back clip shows through at the edges of the key. This creates a better blend at the edges of the key.

The following calculation is applied to each pixel of the image to create the composite. The calculation is applied in three passes, one each for the R, G, and B values of the front and back images, and the pixel is given the resulting R, G, and B values.

$$\text{Result} = F * \text{FrontLUT} + B * \text{BackLUT}$$

where:

F = the R, G and B values of the front image.

B = the R, G and B values of the back image.

FrontLUT is the front matte pixel value, remapped according to any luminance curve change made in this menu. The value is expressed as a decimal, where, for example:

in 8-bit mode, 0 = 0, 127.5 = 0.5 and 255 = 1

in 12-bit mode, 0 = 0, 2047.5 = 0.5 and 4095 = 1

BackLUT is the back matte pixel value, remapped according to any luminance curve change made in this menu. The value is also expressed as a decimal.

To adjust the luminance curve:

- 1 In the Keyer, click Keyer, and then click Luminance.
- 2 If the histogram is displayed, tap the swipe bar underneath it. The Luminance curve appears.

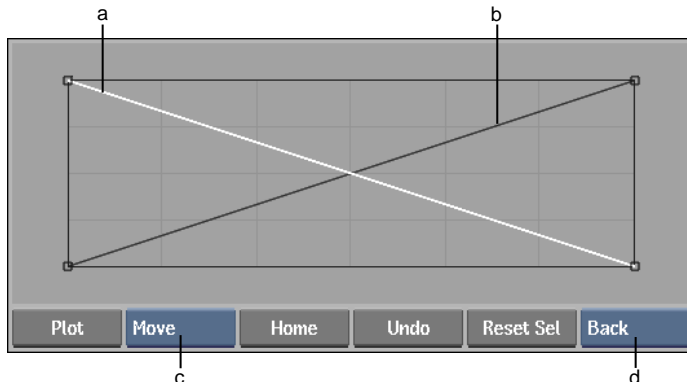

(a) Front matte curve (b) Back matte curve (c) Edit Mode box (d) Front/Back box

- 3 Use the View box to select the image you want to view as you adjust the curves.

Select:	To view:
Result	The composite clip.
Matte	The front matte. You cannot see changes made to the back matte when this view is selected.
Bmatte	The back matte. You cannot see changes made to the front matte when this view is selected.
Comp	The composite with a coloured background. The default colour is black. To select a different colour, click the colour pot to the right of the Comp button. The colour picker appears. See Picking Colours on page 71.
Key In	The image that was used to pull the key.
Back	The background image that is revealed when the front is keyed.
Front	The image to which you applied the key.

- 4 To adjust the luminance curve for the front matte, select Front from the Front/Back box. To adjust the back matte curve, select Back. Alternatively, click a curve to select it.

The selected curve changes to white.

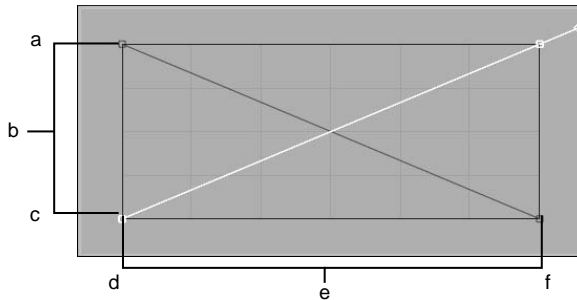

(a) 255 (White) (b) Output (remapping of luminance values) (c) 0 (Black) (d) 0 (Black) (e) Input (current luminance values) (f) 255 (White)

- 5 In Move edit mode, click a point to display its tangent handle and drag the handle to adjust the curve. Use other modes in the Edit Mode box to

further adjust the curve, adding or deleting points or breaking tangent handles, as needed.

Refining the Key

After creating the key and adjusting the luminance, you can modify the edges of the key by blurring the key-in clip or the edge of the matte, applying filters to the edge of the matte, or inverting and then adjusting the matte. You can also suppress colour spill and blend the front and back clip.

To refine a key created from the Master Keyer menu, see the pertinent sections in [Creating and Refining a Key](#) on page 1548.

Modifying the Edges of the Key

Use the Shrink, Erode, and Blur controls in the Matte menu to enhance the edge of the keyed image.

To access the Matte menu:

- 1 In the Keyer, click Keyer.
The Matte controls appear.



Use:	To:
Shrink	Remove pixels from the edge of the matte. This control should not be used when the object in the front clip has soft edges, such as hair.
Erode	Blend the light and dark edges of the matte.

Use: **To:**

Blur Apply a softening filter to the edge of the matte. You can select either a Gaussian filter or Box filter.

To shrink the edge of the matte:

- 1 In the Matte menu, enable Shrink.
- 2 Set a value in the Shrink Width field.



(a) Shrink Width field (b) Blur Width field (c) Erode Width field

This value specifies the width of the border, in number of pixels, that is removed from the edge of the matte.



The matte before enabling the Shrink filter



The matte after setting the shrink width value to 1.00

To erode the edge of the matte:

- 1 In the Matte menu, enable Erode.
- 2 Set a value in the Erode Width field.



This value specifies the width of the matte border, in number of pixels, that will be softened.



The matte before enabling the Erode filter



The matte after setting the erode width value to 1.00

To blur the edge of the matte:

- 1 In the Matte menu, enable Blur.
- 2 Set values in the Blur Width and Height fields.



These values specify the width and height of the Blur filter applied to the edge of the matte.



The matte before enabling the Blur filter

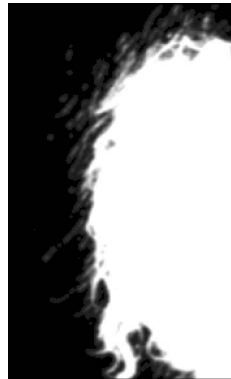

The matte after setting the blur width and height values to 1.00

To select a filter option:

- 1 In the Keyer, click Setup.
- 2 From the Filter box, select the type of blur filter you want to apply.



Select:	To:
Gaussian Filter	Produce a subtle effect using subpixel resolution. Gaussian blurs usually produce a smooth blur.
Box Filter	Produce a blur that requires less processing.

Blurring Grainy Clips

Graininess can make it difficult to pull a clean and effective key. In the Setup menu, you can use the Degrain and KeyIn Filter controls to remove film grain:

- Use Degrain to modify the size of the grain and de-sharpen the edges of the key. The front clip is not affected when you apply Degrain to the key-in clip.

NOTE The same Degrain tools are also available in the Master Keyer. Use the Degrain tools in the Keyer's Setup menu to affect all the Keyer's ranges, or use them in the Master Keyer to affect only the Master Keyer.

- Use the KeyIn Filter to apply a blur filter to the key-in clip and create a soft matte—this makes it easy to achieve a good tolerance range. The front clip is not affected by this blur filter.

To access the Setup menu:

- 1 In the Keyer, click Setup.
The Setup menu appears.

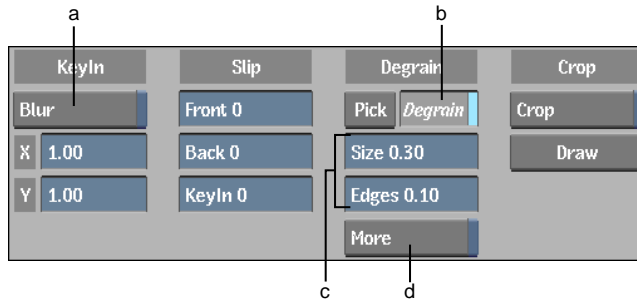

(a) Blur filter (b) Degrain button (c) Degrain parameters (d) More button

NOTE Degrain parameters are animatable. Degrain samples are also animatable and appear in the Channel Editor as the Degrain_Matrix channel, located in the Key_Degrain folder.

To remove grain using Degrain:

- 1 In the Setup menu, click Pick.



- 2 Sample a grainy area of the image. To sample a single pixel, click the image. To sample an area of the image, **Ctrl-drag** a selection box. The Degrain button is enabled and the algorithm is applied to the image—grain is removed from the image.

NOTE The Degrain button is either enabled or disabled for the entire clip—you cannot turn it on and off for different frames in the clip.

- 3 Drag in the Degrain fields to modify the grain size and restore edge sharpness.

Drag: **To:**

Size Estimate the size of the grain in the image.

Drag:	To:
Edges	De-sharpen the edge of the image. By default, Degrain sharpens the edges. Use the Edges field to restore the natural look of the edges in the image.

- 4 If you are not satisfied with the result, you can start over with a new sample, and then adjust the Degrain fields. To resample an area of the image, enable Pick and then **Ctrl+Alt**-drag the image. The sample is outlined in green, indicating that you are resampling the image.
- 5 If resampling the image and adjusting the Degrain fields does not sufficiently remove grain, enable More to increase the overall affect of Degrain.

NOTE The More button is either enabled or disabled for the entire clip—you cannot turn it on and off for different frames in the clip. When you enable More, processing speed slows down.

To apply a KeyIn filter to a grainy key-in clip:

- 1 In the Setup menu, enable Blur.

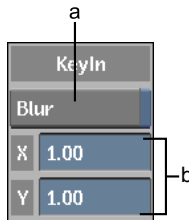

(a) Blur button (b) X and Y Blur fields

A default box blur with a radius of 1 pixel is applied to the key-in clip.

- 2 If necessary, change the horizontal and vertical blur radius values in the X and Y fields. These values specify the width and height of the Blur filter applied to the key-in clip.
- 3 From the Filter box, select the type of blur filter you want to apply.

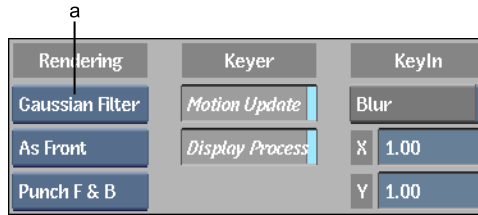

(a) Filter box

Select:	To:
Gaussian Filter	Produce a subtle effect using subpixel resolution. Gaussian blurs usually produce a smooth blur.
Box Filter	Produce a blur that requires less processing.

Inverting the Matte

Use the Matte menu to invert the matte. Any Gain and Lift level adjustments made to the matte are not inverted when you invert the matte. You must therefore invert the matte before adjusting the Gain and Lift levels.

To invert the matte:

- 1 In the Keyer menu, enable Invert.



Suppressing Colour Spill

After you create a key and key out any trouble areas, some of the background colour may have spilled over at the edge of the key. In the Keyer, you can use the colour suppression tools to suppress or disguise colour spill in the front clip. You can:

- Use Spill controls in the Keyer or Colour menu to suppress a selected colour and shift colours adjacent to the selected colour.
- Adjust the Suppression curve in the Colour menu to suppress a selected colour.
- Adjust the Hue Shift curve in the Colour menu to perform a hue shift on a selected colour.

Adjusting Spill Controls

Use the Spill controls in the Keyer or Colour menu to eliminate and disguise the colour spill in any key you create except a luminance key. You can sample the colour you want to remove, and then adjust the Range and Hue fields to suppress the selected colour and shift its adjacent colours.

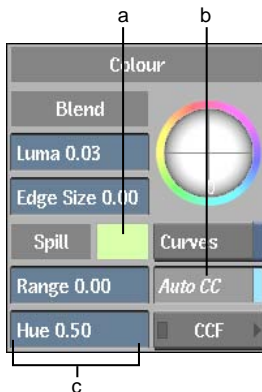

(a) Spill Colour pot (b) Auto CC button in Range menu (c) Spill fields

When you sample an image to generate a key from a Range menu, the sampled colour in the Spill colour pot is also updated. However, the inverse is not true—if you sample a colour using the Spill colour pot, sampled colours used to generate keys are not updated. You can therefore sample colour spill without affecting the original sample.

NOTE To apply these settings to the key, the Auto CC button must be enabled.

To remove colour spill from a key:

- 1 Click Result so that you can see changes as you make them.
- 2 In the Keyer, do one of the following:
 - Click Keyer to show the Keyermenu.
 - Click Colour to show the Colour menu.
- 3 Enable Auto CC to apply the Spill settings to the front clip.
- 4 The Spill colour pot displays the colour that will be suppressed in the clip. By default, the original colour extracted from the key-in clip is displayed. In many cases, you can use this colour because the colour spill is the same colour as the original colour. However, if the colour spill is not the same, change the colour sample. Click the colour pot, use the colour picker to sample the colour spill in the image window, and then click the colour pot again.

NOTE When you select the colour you want to key from a Keyer menu, the colour that appears in the Spill colour pot is automatically updated to match the key colour. However, the inverse is not true—when you sample a colour from the Spill colour pot, the sampled colour used to generate a key is not updated.

- 5 Drag in the Spill fields to remove the colour spill.

Drag:	To:
Range	Suppress the primary sample colour where there is colour spill (along the edges of the key).
Hue	Modify colours that are adjacent to the primary sample and further remove colour spill.

NOTE You can reset the Spill parameters, Blend parameters, and the Edge Balance trackball by clicking Reset, located left of the Edge Balance trackball.

Adjusting the Suppression Curve

If the edge of your key is relatively small, you can eliminate colour spill by suppressing it from the Colour menu. Sample the colour you want to suppress and then suppress that colour where necessary.

To apply settings from the Colour menu to the key, the Curves button must be enabled in the Colour or Keyer menu. The Curves button is enabled by default.

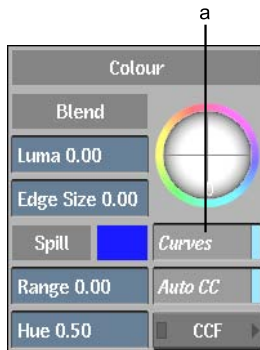

(a) Curves button in Colour menu

To suppress colour spill:

- 1 Click Result so that you can see the changes as you make them.
- 2 Click Colour.
The Colour menu appears.

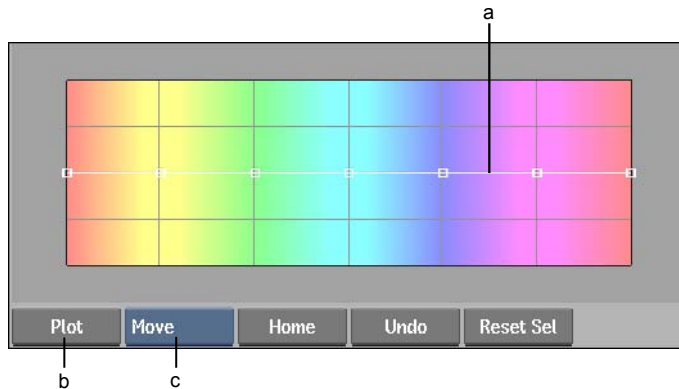

(a) Colour curves (b) Plot button (c) Edit Mode box

The Colour menu displays colour curves over a hue spectrum. When you modify the shape of a curve over a region of the spectrum, only those colours are affected.

- 3 Enable Curves to apply the colour curves of the hue spectrum to the front clip.

NOTE When the Curves button is disabled, settings in the Colour menu are bypassed.

- 4 Click Supp to modify the Suppression curve.
- 5 The colour pot next to the Suppress button displays the colour that will be suppressed in the clip when you modify the curve. By default, the original colour extracted from the key-in clip is displayed. In many cases, you can use this colour because the colour spill is the same colour as the original colour. However, if the colour spill is not the same, change the colour sample. Click the colour pot, use the colour picker to sample the colour spill in the image window, and then click the colour pot again.

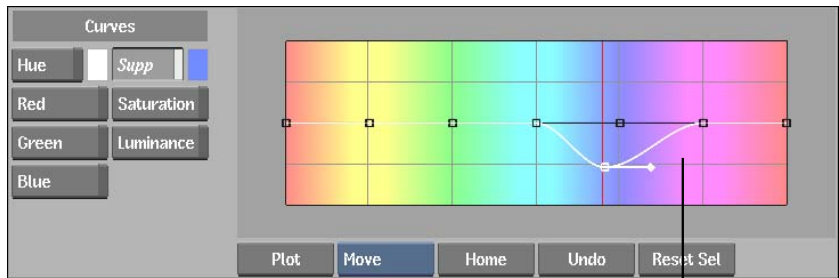

(a) Suppressed colour curve

- 6 Click Plot.
The cursor turns into a colour picker.
- 7 Select a pixel within the spill.
A red vertical bar appears in the hue spectrum identifying the colour to be suppressed.
- 8 Select Move from the Edit Mode box so you can use the cursor to move the points along the Suppression curve.

- 9 On the Suppression curve, drag the point closest to the plotted colour down to a value of 25, intersecting the plotted colour.
The colour spill is suppressed.
- 10 Continue modifying the shape of the curve until you are satisfied with the result.
- 11 Click Saturation to adjust the saturation of the spill.

NOTE Once you remove the saturation from a spill, you may want to increase the values for the other curves (for example, red and green if you removed a blue spill) to reconstruct some of the natural colours at the edge of the keyed image.

- 12 Click Red, Green, or Blue to edit individual colour curves.
- 13 Click Luminance to adjust the luminance of the spill.

NOTE To apply changes made in the Colour menu, make sure the Adjust button is enabled.

Adjusting the Hue Shift Curve

You can disguise colour spill by shifting its hue so the colour blends better with the background. Sample the colour to which you want to shift the colour spill and then adjust the Hue Shift curve to shift the colour spill accordingly.

To apply settings from the Colour menu to the key, the Curves button in the Keyer or Colour menu must be enabled. The Curves button is enabled by default.



(a) Curves button in Colour menu

To create a hue shift:

- 1 Click Result so that you can see the changes as you make them.
- 2 In the Keyer, click Colour.
The Colour menu appears.

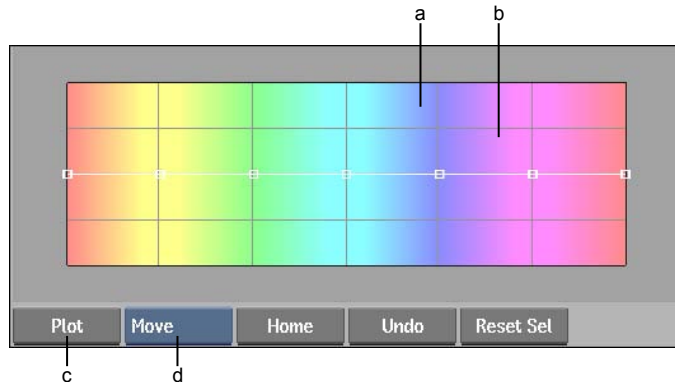

(a) Hue spectrum (b) Colour curves (c) Plot button (d) Edit Mode box

The Colour menu displays colour curves over a hue spectrum. When you modify the shape of a curve over a region of the spectrum, only those colours are affected.

- 3 Enable Curves to apply the colour curves of the hue spectrum to the front clip.

NOTE When the Curves button is disabled, settings in the Colour menu are bypassed.

- 4 Enable Hue to modify the Hue Shift curve.
- 5 Click the colour pot next to the Hue button.
The colour picker appears.
- 6 Select or pick a colour.
- 7 Click again inside the colour pot next to the Hue button to set the Hue colour.
- 8 Click Plot.
- 9 Select a pixel within the spill.

A red vertical bar appears in the hue spectrum identifying the colour to be shifted.

- 10 Select Move from the Edit Mode box so you can use the cursor to move the points along the Suppression curve.
- 11 On the Hue Shift curve, drag the point closest to the plotted colour down to a value of 75, intersecting the plotted colour. The colour spill is shifted toward the Hue colour.
- 12 Continue modifying the shape of the curve until you are satisfied with the result.

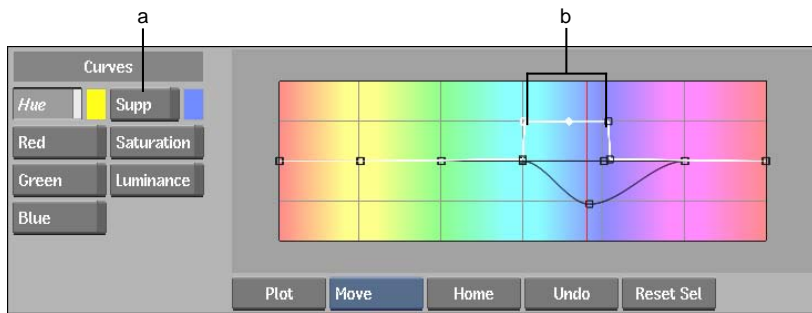

(a) Hue Shift colour (b) The colour values in the image that fall in this range (under the curve) are shifted to the Hue Shift colour

Blending the Front and Back Clip

Use the Blend controls in the Keyer or Colour menu to blend the front and back clip in any key you create except a luminance key. The Blend controls change the blending that occurs at the edges of the key but should not greatly affect the black and white areas of the key. You can sample the colour you want to remove, and then adjust the Edge Balance trackball and Blend controls to emphasize the front or back clip at the edges of the key.

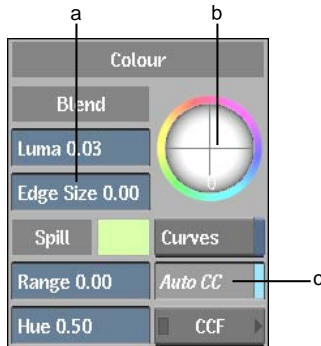

(a) Edge Balance trackball (b) Blend controls (c) Auto CC button in Range menu

NOTE To apply these settings to the Key, the Auto CC button must be enabled.

To adjust the edge of the key and blend the front and back clips:

- 1 Click Result so that you can see the changes as you make them.
- 2 In the Keyer, do one of the following:
 - Click Keyer to show the Keyer menu.
 - Click Colour to show the Colour menu.
- 3 Enable the Auto CC button to apply the settings in the Blend fields and the Edge Balance trackball to the front clip.
- 4 Adjust the Blend controls to integrate the front and back clips.

Adjust:	To:
Luma	Darken or lighten the edge of the key. Blend Luma only affects the luma of the edge.
Edge Size	Set the range for the blend. Drag right to soften the edge and blend further into the key. Drag left to harden, or create a thinner, edge. Blend Edge Size affects both Blend Luma and Edge Balance.
Edge Balance trackball	Add a cast to the edge of the key and improve the overall look by matching the edge with a colour cast in the back clip. Drag the Edge Balance trackball toward the colour you want to add. The Edge Balance trackball only affects the chroma of the edge.

NOTE You can reset the Spill parameters, Blend parameters, and the Edge Balance trackball by clicking Reset, located left of the Edge Balance trackball.

Colour Correcting the Key

Use these procedures when you have to colour correct your clip before processing the matte.

You can adjust the saturation, luminance, or individual red, green, and blue channels of the result clip. You can also colour correct the front clip independently of the key-in clip, even though they are both drawn from the same source.

Colour Correcting the Result Clip

Use the colour channel curves in the Colour menu to colour correct the result composite. By default, these colour corrections affect the keyed front clip after it is blended with the back clip.

To colour correct the result composite:

- 1 Click Result so that you can see the changes as you make them.
- 2 In the Keyer, click Colour.
The Colour menu appears.

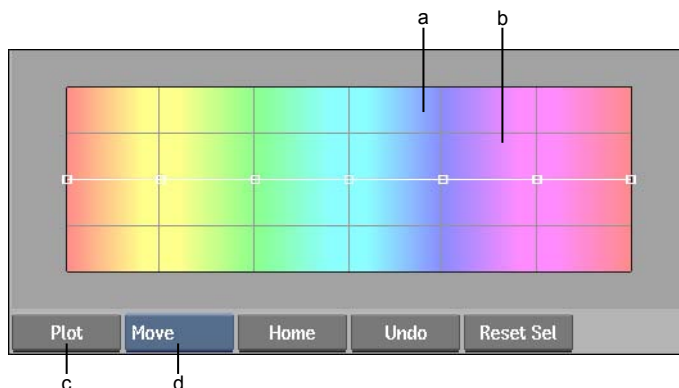

(a) Hue spectrum (b) Colour curves (c) Plot button (d) Edit Mode box

The Colour menu displays colour curves over a hue spectrum. When you modify the shape of a curve over a region of the spectrum, only those colours are affected.

- 3 Enable Curves to apply the colour curves of the hue spectrum to the front clip.

NOTE When the Curves button is disabled, settings in the Colour menu are bypassed.

- 4 Click the button that corresponds to the colour channel that you want to adjust: Saturation, Red, Green, or Blue, or Luminance.
- 5 Edit the colour curves using the options in the Edit Mode box. For example, select Move so you can use the cursor to move the points along the curve:
 - Move control points up to boost the corresponding channel value for the hue spectrum covered by that region of the curve. For example, boost red in the blue region of the hue spectrum to make blue pixels purple.
 - Move control points down to boost the corresponding channel value for the hue spectrum covered by that region of the curve. For example, lower saturation in the yellow region of the hue spectrum to mute yellow pixels.
- 6 Continue to modify the shape of the curve until you are satisfied with the result.

Colour Correcting the Front Clip

You can use the Colour Corrector to correct the front clip and improve the look of the key.

To colour correct the front clip:

- 1 Click the CCF button in the Keyer or Colour menu to bring the front clip into the Colour Corrector.



(a) Indicator (b) CCF button

When a colour correction is made, a blue indicator appears on the CCF button.

NOTE To view the colour correction you apply to the front clip, make sure Result is selected as the view output option. If the Front and Adjust buttons are both enabled, the colour curves are applied first, and then the colour correction setup.

2 Do one of the following:

- To disable the colour correction, click the blue indicator on the CCF button.
The indicator turns yellow, showing that there is a colour corrector setup available but it is currently disabled.
- To remove the colour corrector setup completely, hold **Alt** while clicking the CCF button.

Animating Your Key

The following parameters of a key can be animated:

- The average colour selected using the Average Colour pot in the Keyer menu
- The minimum and maximum Tolerance and Softness values
- The Lift, Gain, Shrink, and Erode values

- The blur factors for the matte and key-in clip
- The Maximum and Minimum Input and Output level values for the histogram

To display the Animation controls in the Keyer, click Animation. Using the Channel Editor, animate the parameters. See [Animation](#) on page 1963.

Motion Update

When you play or scroll the clip in the image window, the image is updated to reflect any animation of the properties of the key. You can disable this default by disabling the Motion Update button in the Setup menu. When disabled, the image window is not updated to reflect keyed parameters.

Disabling Motion Update is useful for copying keyframe values from one frame to another. See [Copying and Pasting Channels or Keyframes](#) on page 2001.

Additional Keying Techniques

The following optional techniques can help with the creation of keys and speed up processing time.

Viewing a Key with a Solid Colour Background

While creating the key, you can view the composite using a solid colour for the background in place of the back clip. This can help you see details in the image, such as colour spill, that you may otherwise miss. You can use the default colour (black) or select a colour using the colour picker.

NOTE This view does not affect the final render.

To use a solid colour background:

- 1 In the View box, select Comp.
A colour pot appears.

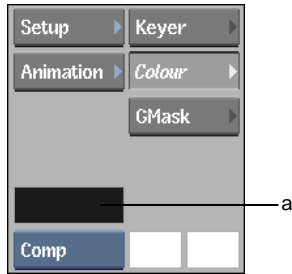

(a) Colour pot

NOTE If you colour corrected the Front clip in the previous section, click RETURN in the Colour Correction menu to access the Comp view option.

- 2 Click the colour pot above the Comp view output option.

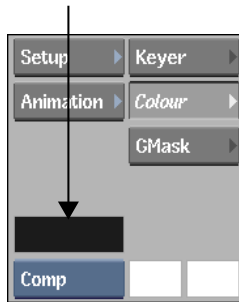

The colour picker appears.

- 3 Select a colour for the background using the colour picker. See [Picking Colours](#) on page 71.

Cropping the Key Area

You can limit the keyed area by drawing a crop box on the image.

To draw the crop box:

- 1 In the Keyer, click Setup.



The Setup menu appears.



- 2 Enable Draw Crop.
- 3 Draw the crop box by selecting a point on the image and dragging the cursor diagonally.
- 4 Click Crop to enable the crop box.

Keying operations now affect only the cropped area.

NOTE When the clip is processed with the crop box enabled, only the cropped area is keyed. Remember to disable the crop box if you want to apply the key to the entire frame.

Resetting Keys

You can reset the entire Keyer. You can also reset the current Keyer menu.

To reset the Keyer:

- 1 Click Reset All, and then confirm.



To reset the current Keyer menu:

- 1 In the Keyer menu, click Reset Keyer, and then confirm.



Processing Clips

Once you finish creating your composites, process the clips to the Flame. You can generate either a composite clip or a matte clip.

To process the composite clip:

- 1 In the Setup menu, set the processing options. See [Processing Options](#) on page 1599.
- 2 Select Result view to display the composite clip.
- 3 Click Process.

To process the front matte:

- 1 In the Setup menu, set the processing options. See [Processing Options](#) on page 1599.
- 2 Select Matte view to display the matte.
- 3 Click Process.

To process the back matte:

- 1 In the Setup menu, set the processing options. See [Processing Options](#) on page 1599.
- 2 Select BMatte view to display the back matte.
- 3 Click Process.

Processing Options

Use the following options in the Setup menu to improve the output and reduce processing time.

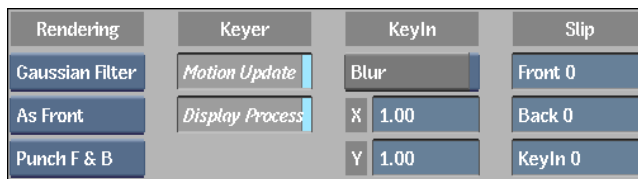

(a) Rendering control (b) Slip controls (c) Punch box (d) Display Process button

Field and Frame Rendering

You can render interlaced or progressive frames. If you select the Interlaced option in the Rendering box, the Keyer combines the two fields and renders each frame. If you select the Progressive option, the Keyer renders each field

separately. Use the Interlaced option if the two fields in the image are not properly aligned and if the filters you are using are not applied to the proper pixels.

A third option, As Front (or As Input if you have accessed the Keyer from Action), renders using the mode that corresponds to the source clip (or the scan mode attribute of the Action media).

NOTE The Field rendering option does not work if you select the Box filter in the Setup menu.

Punch Mattes Options

When you pull a key, a matte is created for both the front and back images. If you modify the luminance curves for both mattes, you can specify whether both mattes are used in the generation of the composite clip, or only the back matte. To do this, use the Punch Mattes options:

- Punch F & B uses both the front and back mattes. This is appropriate for clips that do not contain a pre-multiplied alpha channel, such as clips originating from CG applications.
- Punch Back uses the back matte only. The luminance curve for the front matte is ignored, resulting in an additive key. Use Punch Back when you are using a CG clip with a pre-multiplied alpha channel in which the area to be keyed out is black. On these clips the front matte has been previously applied to the front image. If the front matte is applied a second time, an unwanted black fringe may result along the edges of the matte subject.

When the front matte is not used, the entire front image is used, and the curves calculation maps all the black areas of the front clip as transparent. For complete details about the Blending menu, see [Using the Luminance Curves](#) on page 1573.

Displaying the Key while Processing

In the Setup menu, enable the Display Process button to view the composite clip as it is processed. When this button is disabled, the image window remains at frame 1 during processing. You can reduce processing time by disabling Display Process.

Slip Syncing

You can offset the front, back, and key-in clips using the Slip fields in the Setup menu. You can delay the start of a clip or start anywhere in a clip; this way you do not have to exit the Keyer to edit the length or sequence of a clip.

Topics in this chapter:

- [About the Modular Keyer](#) on page 1603
- [Accessing the Modular Keyer](#) on page 1604
- [Using Nodes](#) on page 1629
- [Blend Nodes](#) on page 1647
- [Animation in the Modular Keyer](#) on page 1658
- [Nodes Placement Table](#) on page 1658

About the Modular Keyer

Use the Modular Keyer to pull a key and to selectively colour correct a clip. The processing pipeline provides an environment in which you can select and arrange the keying tools. You can select from an array of tools to create your key:

- The 3D Keyer, which provides automatic noise reduction, a 3D histogram to view the colours in a clip, and methods to refine the key. See [3D Keyer](#) on page 1661.
- The Keyer, which can be used as an alternative to the 3D Keyer, lets you key images by extracting a single colour or a range of colours, or by setting the luminance. See [Keyer](#) on page 1545.

- The Master Keyer, another alternative to the 3D Keyer, allows you to refine keys by gesturally modifying the matte, removing colour spill, blending edges, applying patches, and removing grain. See [Keyer](#) on page 1545.
- The 2D histogram to adjust the luminance of the matte.
- Garbage masks, used for revealing or hiding explicit parts of the matte. You can also use the Tracer to key difficult images. See [Garbage Masks](#) on page 1707.
- Colour suppression and edge correction tools.
- Colour correction, including the Colour Warper, a tool for performing localized colour correction.
- Degrain and regrain tools.
- Difference matte.
- Containers for doing multilayered mattes and colour corrections.
- Logic operations to blend the components of matte layers.

Accessing the Modular Keyer

As with the traditional Keyer, you load three clips into the Modular Keyer to create a key: a front clip, a back clip, and a key-in clip. You use the key-in clip, which is usually the same as the front clip, to create the matte for the front clip.

NOTE For information on accessing the Modular Keyer from Action, see [Accessing the Colour Corrector and the Keyer from Action](#) on page 2150.

To access the Modular Keyer:

- 1 In the Main menu, click Effects.
- 2 In the Effects menu, click Modular Keyer.
- 3 Select a front, back, and key-in clip. Make sure the front, back, and matte clips are the same resolution. If not, resize them. See [Resize Settings](#) on page 681.
- 4 Select a destination.
The Modular Keyer menu, shown below, and the processing pipeline appear.

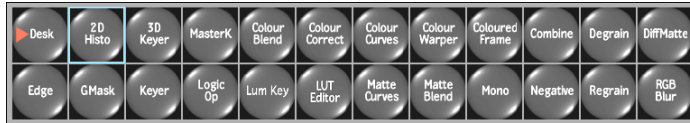

Setting Up the Processing Pipeline

To build your key, you can use the tools provided on the default processing pipeline as well as add tools. You can also remove tools and set up the pipeline to best suit your needs. Each tool is represented by a process node that you can click to access the node's menu.

The pipeline is made up of three processing branches—one each for the front, back, and matte clips, as shown in the following image.

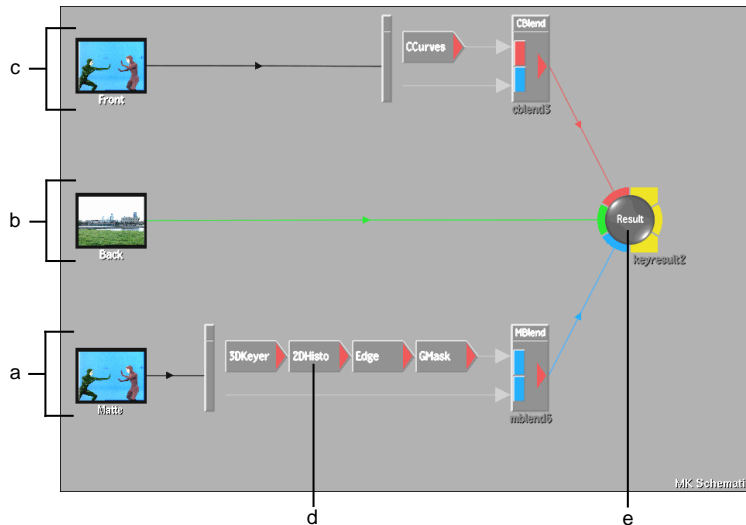

(a) Matte branch (b) Back branch (c) Front branch (d) Process node (e) Result node

Red is used for the outline of the front clip proxy and branch, green is used for the back clip, and blue is used for the key-in clip. These colours correspond to the colours of the arrow cursor when selecting clips from the desktop.

The processing pipeline is similar to the process tree of the Batch module, except that its main purpose is to create a key. Unlike Batch, most of the nodes that you use in the processing pipeline have one input and one output. This

allows for a more streamlined schematic. For more information on the Batch module, see [Batch Processing](#) on page 1283.

The processes on the pipeline are performed sequentially in the direction of the arrows shown on each branch. The result of each branch is fed into the Front, Back, and Matte tabs of the Result node to create the composite.

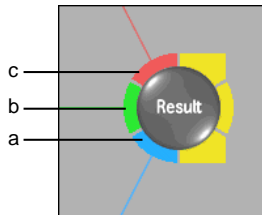

(a) Matte tab (b) Back tab (c) Front tab

To process the composite—the output of the Result node—to the destination reel, you click the Process button in the Modular Keyer menu.

The default pipeline that you see when you first access the Modular Keyer contains certain nodes. These nodes correspond roughly to the functions of the traditional Keyer:

- On the Front branch, the CCurves node opens the Colour menu, where you can remove colour spill from the front clip, perform a hue shift, for example.
- On the Matte branch:
 - The 3D Keyer node opens the 3D Keyer, where you can pull the key.
 - The 2D histogram node opens the histogram, where you can adjust the luminance of the matte.
 - The Edge node opens the Edge menu, where you can adjust the edges of the key using shrink, erode, blur, for example.
 - The GMask node opens the Garbage Mask menu, where you can create garbage masks.
- The Result node opens the Matte Curves menu, where you can adjust the front and back mattes.

If the node for the operation you want to perform on a clip is not already on the pipeline, you add it to the appropriate branch. For example, if you want to blur the front clip, add an RGB Blur node to the Front branch.

Displaying Menus

Menus are built into the schematic, so you need only click a node to access its menu. The only exceptions are the Gmask (garbage mask) and CC (colour corrector) nodes. After clicking the GMask or CC node, you click another button to open the module. These modules are not integrated into the Modular Keyer in the same way as the other modules are—you cannot access the pipeline or the Modular Keyer menu options during an edit session.

To access a menu for a node:

- 1 Select Move from the Edit Mode box.



- 2 Click the node.

The node has a yellow border, and the menu appears in the lower part of the screen.

Modular Keyer Menu

The Modular Keyer menu provides the commands you need to:

- Set up the processing pipeline the way you want.
- Change the image displayed in the image window.
- Play and process the clip.
- Save the key setup.

Viewing Clips in the Image Window

Use **Esc** to switch from the schematic (pipeline) to the image window, and vice versa. You can use the view options, or the equivalent hot keys, to change the image that appears in the image window.

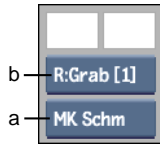

(a) View box (b) Reference View box

Select a view from the View box to display one of the following views in the image window.

NOTE Hot keys are shown in parentheses.

Select:	To view:
Front (F1)	The front clip of the selected node.
Back (F2)	The back clip of the selected node.
Matte (F3)	The matte of the selected node.
CurResult (F4)	The result of the selected node.
Grab	The reference image created when clicking Grab in the View menu of the Modular Keyer. See Storing Reference Frames in the Reference Buffer on page 133.
MK Schematic (Esc)	The processing pipeline. The Esc hot key toggles between the schematic (the pipeline) and the last selected view.
Result	The resulting output of the entire processing pipeline.
Action Result	The Action context point (available only when accessing the Modular Keyer from Action).
Channels	The Channel Editor.
Context 1 (1)	The context of context point 1. See Setting a Context Point on page 1624.

Select:	To view:
Context 2 (2)	The context of context point 2. See Setting a Context Point on page 1624.

Select a view from the Reference View box to display one of the following alternate views in the image window. There are no hot keys for the reference views.

Select:	To view as a reference:
R:Result	The result of the changes made in the selected node.
R:Context1	Context Point 1. See Setting a Context Point on page 1624.
R:Context2	Context Point 2. See Setting a Context Point on page 1624.
R:Back	The current back clip of the selected node.
R:Grab [1]	The reference image created when you click Grab in the View menu of the Modular Keyer. See Storing Reference Frames in the Reference Buffer on page 133.
R:Front	The current front clip of the selected node.
R:Matte	The current matte clip of the selected node.

The Current Result proxy shows the Current Result view (see CurResult in the first table). It is updated as you select different nodes on the pipeline or make changes in a menu. You can also click it to update it.

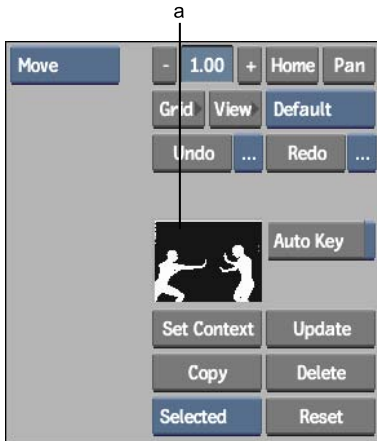

(a) Current Result proxy

About Nodes

There are three types of processing nodes you can use on the pipeline:

- Single input nodes
- Multiple input nodes
- Blend nodes

Single Input Nodes

The simplest type of node has a single input and output.

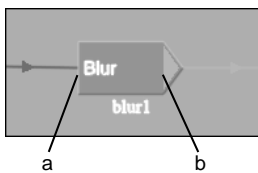

(a) Input (b) Output

Examples of this type of node are the 3D Keyer, Edge, and RGB Blur nodes.

Multiple Input Nodes

A multiple input node has one to four coloured tabs used to connect inputs and outputs. The colour tabs on the node's left are called *source tabs*. The source tab colours correspond to the cursor colours when selecting clips from the desktop reels. The yellow tab on the node's right is the *result, or output tab*.

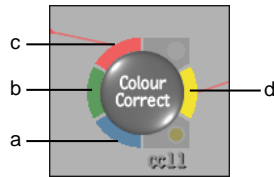

(a) Matte tab (b) Back tab (c) Front tab (d) Result tab

Tab	Colour	Purpose
Front	Red	Use to connect a source for the front clip of the node.
Back	Green	Use to connect a source for the back clip of the node.
Matte	Blue	Use to connect a source for the matte clip of the node.
	Grey	Unused tab.
Result	Yellow	Use to connect the result of the node to one or more other nodes.

The tabs that are available depend on the node. If the node accepts a front, back, and matte clip, all source tabs are available. If the node only accepts a front and back clip, the red and green source tabs are available and the blue source tab is grey. The result tab is always available, except on the Result node, which is the last node in the pipeline.

When source tabs are not connected to anything (clips or other nodes), the tabs are slightly greyed.

Examples of multiple input nodes are the Result, Colour Correct, Regrain, and MasterK nodes.

Blend Nodes

The Front and Matte branches each contain a special node that includes two lines containing other nodes—the CBlend and MBlend nodes. The nodes in these two lines are processed sequentially, as in a branch. Because these lines

function somewhat differently from a branch, they are referred to as pipes. The two pipes in the following example constitute a layer within the CBlend node.

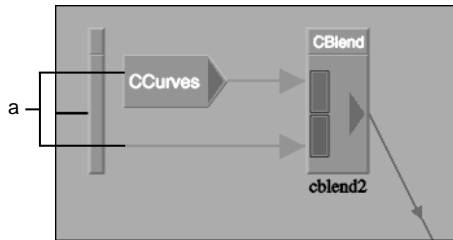

(a) Two pipes

Use the nodes on the CBlend pipes to apply colour corrections and other processes to clips. Use the nodes on the MBlend pipes to create a matte for the composite.

The two pipes of blend nodes provide extra functionality compared to branches in the pipeline:

- You can apply the processes to a selected region of the image. You use the lower of the two pipes to define the area on the image where you want to apply the processes used in the upper pipe. For example, you could add a garbage mask node to the lower branch and create a matte. The processes in the upper pipe are only applied to the foreground subject of the matte. If there are no nodes in the lower pipe, the processes in the upper pipe are applied to the entire image.
- You can blend the two pipes in various ways.
- You can use multiple layers. The two pipes together constitute a layer. You can add one to three additional layers to blend nodes.

For more information, see [Blend Nodes](#) on page 1647.

Working with Nodes

This section describes how to perform basic operations to set up your pipeline, such as adding nodes to the pipeline and moving them.

For information on individual nodes and where on the pipeline they can be used, see [Using Nodes](#) on page 1629 and [Nodes Placement Table](#) on page 1658.

Selecting Nodes on the Pipeline

You can select individual nodes, branches, all nodes in the pipeline, or all nodes in the schematic. You can also use the **Ctrl** key to select a combination of nodes.

To select nodes in the schematic:

- 1 Select Move from the Edit Mode box.

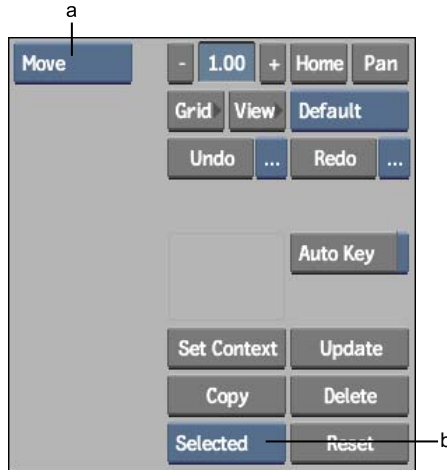

(a) Edit Mode box (b) Selection box

- 2 Select the node(s) as follows.

To select:	Do this:
One node	Select Selected from the Selection box and click the node.
A branch	Select Branch from the Selection box and click anywhere on the branch.
All nodes on pipeline	Select Graph from the Selection box and click anywhere on the pipeline.
All nodes in schematic	Select All from the Selection box and click any node.
A combination of nodes	Press Ctrl and drag a rectangle around the nodes. The current option in the Selection box does not affect this type of selection.

Selected nodes have a white border.

NOTE A yellow border indicates both that a node is selected and that its menu is the active menu.

Adding Nodes to the Pipeline

You can add nodes to the pipeline to use while building your key. For example, you can place several garbage mask nodes on the pipeline.

Most nodes can be placed anywhere on the pipeline. There are a few exceptions when it comes to the pipes of blend nodes. Certain nodes do not function on some pipes because of the way the pipes operate. See [Blend Nodes](#) on page 1647.

The method for adding nodes to blend node pipes differs from the method for adding them to branches:

- When you add a node to the CBlend and MBlend pipes, you can simply drag and drop them onto the pipe and they are “attached”.
- When you add a node to branches of the pipeline (for example, to the Back branch), you need to cut the branch at the appropriate location, connect it to the new node, and reconnect the branch to the rest of the pipeline.

To add a node to the CBlend and MBlend pipes:

- 1 Scroll the node bar to display the node type you want by clicking on any node type and dragging to the left or right.
- 2 Do one of the following:
 - Drag a node type to the schematic and release it in the approximate location you want it to appear.
 - Double-click a node type. The new node appears to the right of the most recently selected node, or group of nodes, in the pipeline. If no node was previously selected, the new node appears in the center of the schematic.

- 3 To use the node, it must be connected to the pipeline. Drag the node over one of the blend pipes and release the cursor.

To place the node:	Do this:
Between two nodes.	Position it between the two nodes such that it is touching both nodes.
At the beginning of a pipe	Overlap it with the first node and move it back a bit.
At the end of a pipe	Overlap it with the last node, move it ahead a bit, and release the cursor.

The node is added to the pipeline.

NOTE If the node is not added to the pipeline when you release the cursor, it is possible that the node cannot be added at that location. For example, you cannot add a Colour Curves node to the lower CBlend pipe. To learn more about the types of nodes you can add to the CBlend and MBlend pipes, see [Blend Nodes](#) on page 1647, and [Nodes Placement Table](#) on page 1658.

To add a node to branches:

- 1 Scroll the node bar to display the node you want by clicking on any node and dragging to the left or right.
- 2 Click the node and drag the cursor to the schematic.
The cursor changes to an arrow-headed cross.
- 3 Release the cursor.
The node appears in the schematic.
- 4 Drag the node closer to the location on the branch where you want to add it.
- 5 Select Parent from the Edit Mode box.
- 6 Drag the cursor across the branch where you want to add the node.
The portion of the branch between the previous and next items disappears.
- 7 Drag the cursor from the front of the previous clip or node (or its Result tab) to the back of the new node.

If the node has source tabs, attach the branch to the front, back, or matte tab, depending on the type of node. See [Using Nodes](#) on page 1629.

NOTE You can also use the output (result image) of any node on the pipeline as an input source for the new node. This includes the output of nodes along the pipes of blend nodes.

The branch is connected to the new node.

- 8 Drag the cursor from the result tab of the new node to the back of the next node (or to the appropriate source tab—see note, above).

Moving Nodes

You can move a node from one part of the pipeline to another. For example, you can move a garbage mask to the beginning of a branch on the pipeline.

To move a node:

- 1 Select Move from the Edit Mode box.
- 2 Detach the node from the pipeline:
 - If it is on a blend node pipe, **Ctrl+Alt**-click the node. It is detached from the pipe, and is selected (shown by its yellow border).
 - If it is on a branch, select Parent from the Edit Mode box and drag the cursor across the branches that connect it to the pipeline. Reconnect the branch without the node, then return to Move mode.
- 3 Drag the node over the pipeline where you want to add it and release the cursor. See [Adding Nodes to the Pipeline](#) on page 1614.

Copying Nodes

You can copy one or more nodes and place the copies elsewhere on the schematic. All the settings of a copied node are included in the copy.

To copy one or more nodes:

- 1 Select the nodes. See [Selecting Nodes on the Pipeline](#) on page 1613.
- 2 Click Copy.

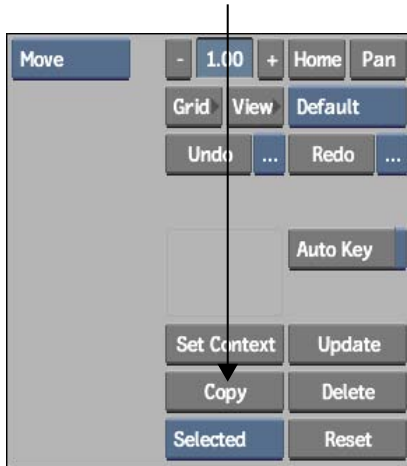

Copies of the nodes appear on the schematic. The copies are selected (shown by the yellow border).

- 3 Drag the copies over the pipeline where you want to add them and release the cursor. See [Adding Nodes to the Pipeline](#) on page 1614.

Deleting Nodes

When you delete a node from the pipeline, all the associated information, including any unsaved work, is also deleted. There are several methods you can use to delete nodes:

- Select the nodes and then delete them.
- Switch to Delete mode and then click the nodes you want to delete.
- Drag the nodes off the desktop.

To select and delete one or more nodes:

- 1 Select the nodes. See [Selecting Nodes on the Pipeline](#) on page 1613.
- 2 Click Delete.

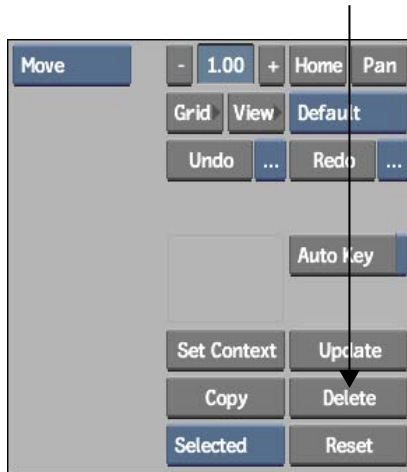

- 3 Click Confirm to delete the nodes, or click elsewhere to cancel.

To use Delete mode:

- 1 Select Delete from the Edit Mode box.
- 2 Click the node you want to delete.
- 3 Click Confirm to delete the node, or click elsewhere to cancel.

TIP To override Confirm, press **Alt** as you click the node.

- 4 Repeat steps 2-3 for any other nodes you want to delete.
- 5 Return to Move mode.

To delete by dragging:

- 1 From the Edit Mode box, select Move.
- 2 From the Selection box, select Current, Branch, Graph, or All.
- 3 In the schematic, click a node and drag either to the top or the bottom of the desktop.
The cursor changes to a green recycling icon.
- 4 Click Confirm to delete the nodes, or click elsewhere to cancel.

Updating Nodes

All the nodes in the pipeline are not updated or processed when a change is made to the pipeline. This is to save time if processing is not needed. For example, when you make a change in one node, that node and all previous nodes in the branch are updated immediately, but not the subsequent nodes.

In the pipeline, the status of a node is indicated differently depending on the type of node.

Node Type	Unprocessed	Processed
Single Input	The arrowhead at the right side of the node is red.	The arrowhead at the right side of the node is green.
Multiple Input	The label under the node is black.	The label under the node is white.
Blend	The arrowhead is red and the label is black.	The arrowhead is green and the label is white.

You can opt to have nodes updated on an “as needed” basis, or update them manually:

- With automatic update, when you click a node, that node and all nodes before it on the pipeline are updated since the previous nodes are required to produce the correct result for the node. For example, if you click the Result node, all nodes in the pipeline are updated.
- With manual update, you selectively update nodes.

To set the update mode:

- 1 Display the Setup menu.
- 2 Use the Auto Update button to set the update mode.

For:	Do this:
Automatic update	Enable the Auto Update button.
Manual update	Disable the Auto Update button.

NOTE Auto Update only affects the schematic (it does not affect processing while you are working within nodes).

To update a node automatically:

- 1 Select Move from the Edit Mode box.
- 2 Click the node.

NOTE If the node does not get updated, make sure that all multiple input nodes in branches leading to the node have the required source inputs.

To update a node manually:

- 1 Select the node. See [Selecting Nodes on the Pipeline](#) on page 1613.
- 2 Click Update.

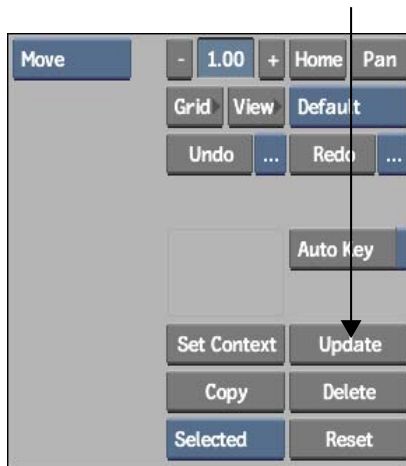

The selected node and all previous nodes are updated.

NOTE If the node does not get updated, make sure that all multiple input nodes in branches leading to the node have the required source inputs.

Renaming Nodes and Clips

Nodes are given a default name composed of the node name and a number appended to it, for example, gmask1, gmask2. When you select a node or clip, its name is displayed in the Name field.



(a) Name field

Names are also displayed in the schematic, below the clip or node (with the exception of the nodes on blend pipes). Rename nodes and clips to help keep track of them as the pipeline grows.

NOTE You cannot rename clips that are brought into the schematic using the Add Clip button.

To rename a node or clip:

- 1 Select the node or clip.
- 2 Click the Name field.
The on-screen keyboard appears.
- 3 Click Esc to delete the previous name and type a new name.
- 4 Click Enter to save the new name or click EXIT Keyboard to cancel.

Adding Clips to the Pipeline

You can add clips to the pipeline to use with nodes that require extra clips. For example, when you use the Difference Matte node, you need two clips.

You can also add new clips to use in place of the Front, Back, or Key-In clips you selected when you opened the Modular Keyer. You may want to replace an existing clip temporarily to see the result, or process the final composite with the new clip.

NOTE When you access the Modular Keyer from Action, Action uses the original Front, Back, and Key-In clips. If you want to replace these clips, you must return to Action and replace them using the Layers menu.

To add a clip to the schematic:

- 1 In the node bar, click the Desk node and drag it to the Modular Keyer schematic.

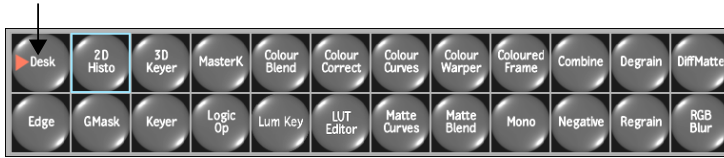

You are brought back to the desktop.

- 2 Select the clip you want to bring into the schematic by clicking its upper-left corner.

You are returned to the Modular Keyer and the clip appears in the schematic.

To attach the new clip to a node:

- 1 Select Move from the Edit Mode box.
- 2 Move the clip to the left of the node you want to attach it to.
- 3 Select Parent from the Edit Mode box.
- 4 Drag the cursor from the right edge of the new clip to the appropriate source tab of the node. If it is a single input node, drag the cursor to the left side of the node.

The clip is connected to the node.

NOTE For more information on using particular types of nodes, see [Using Nodes](#) on page 1629.

To replace an existing clip:

- 1 Select Move from the Edit Mode box.
- 2 Move the clip near the existing clip.
- 3 Select Parent from the Edit Mode box.
- 4 Detach the old clip from the pipeline by dragging the cursor across the part of the pipeline between the old clip and the rest of the pipeline.
- 5 Connect the new clip to the pipeline by dragging the cursor from its right edge to the appropriate source tab of the first node on the branch.

To replace a clip that was added to the pipeline:

- 1 Double-click the clip.

You are brought back to the desktop.

2 Select another clip.

It replaces the previous clip in the pipeline.

TIP Do not leave unused clips in the schematic: each time you process or play the clip, the Modular Keyer reads all clips off the framestore, even if they are not a part of the pipeline.

Clip Controls

You can make a clip begin at a certain frame by using the slip function. This applies only to clips loaded into the Modular Keyer via the Desk node. When you link a clip loaded via the Desk node into the Modular Keyer pipeline, it retains its clip controls.

To slip a clip in the Modular Keyer:

- 1 From the Modular Keyer schematic, click the Desk node.

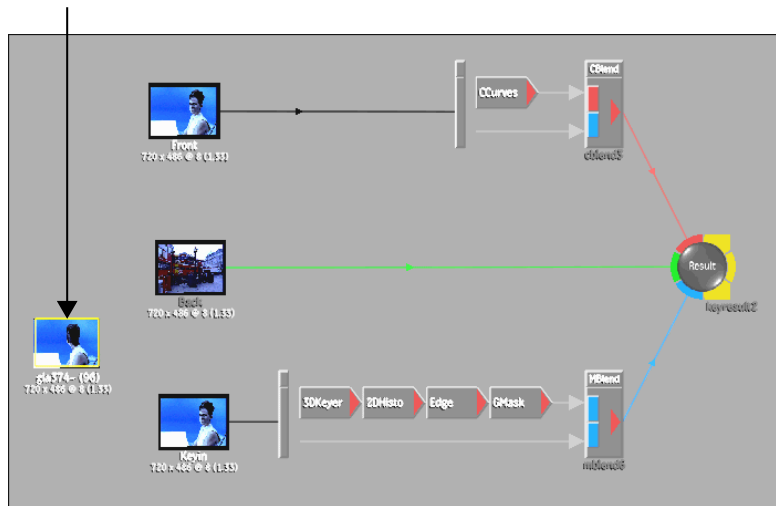

Images courtesy of Behavior Communications Inc.

The Slip field and Lock button appear in the Modular Keyer menu. If the node bar appears, swipe the bar at the left or right of the Modular Keyer menu.

- 2 Change the value in the Offset field to slip the starting frame of the clip.

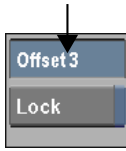

For example, a slip value of -15 holds the clip at the first frame and repeats it 15 times before the clip begins. A slip value of 10 begins the clip at frame 11, since a slip value of zero corresponds to frame 1. Slip information is stored with Modular Keyer setups.

- 3 To lock the currently displayed frame, enable Lock.

Setting a Context Point

As you work with different nodes to create your key, it is often useful to see the effect of your changes on the image at a later part of the pipeline. You do this using context points. You set a context point on a particular node, then view that context point from the node you are working in. For example, you could place a Degrain node at the beginning of the Matte branch and set a context point on the 3D Keyer node. You could then degrain the clip while viewing the context point, in this case, the Current Result of the 3D Keyer.

NOTE To view the context point in this example, you must have pulled a key with the 3D Keyer.

You can set two context points in the pipeline.

To set context points:

- 1 Press and hold = and click the node.
A green dotted border appears around the node and (C1) appears below the label.

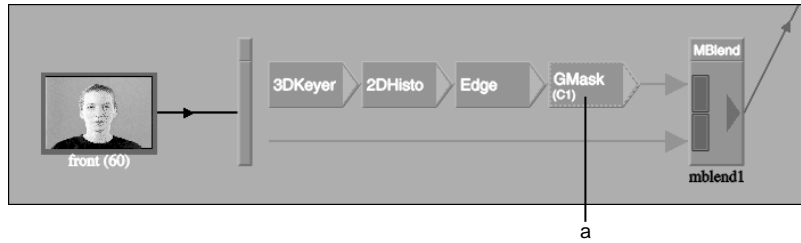

(a) Context Point 1 set on GMask node

- 2 To set the second context point, repeat step 1 on another node. The second context point has the same green border and (C2) appears below the label.

When you next set a context point, the context point that was first set disappears. The (C2) context point is changed to (C1) and the new one becomes (C2). The oldest set context point is always Context Point 1, and the newest one is always Context Point 2. The oldest context point is always the one to get removed when you add a new one.

To view a context point:

- 1 Set a context point, as described in the previous procedure.
- 2 Select the node you want to work with.
- 3 Select Context1 or Context2 from the View box, according to the context point you want to see. Alternatively, press **1** for Context Point 1 or **2** for Context Point 2.

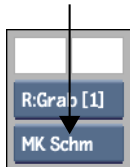

As you make changes, you see the effect the changes are having on the selected context point.

Comparing Colours on Different Images

Use the colour pots in the Modular Keyer menu to compare colours from two different images, or from the same image as it appears in different parts of the pipeline. To do this, you pick the colours from each image and apply them to the two colour pots.

You can also apply a colour that you copied to a colour pot to a colour pot in one of the node menus. For example, apply the colour to the Suppress Colour pot in the Colour Curves menu. For more information on using the colour picker, see [Picking Colours](#) on page 71.

To apply a colour to a colour pot:

- 1 Display the image with the colour you want to sample.
- 2 Click the colour pot.
The colour picker appears.
- 3 Click Pick and then click in the image on the colour.
- 4 Click in the colour pot again.

To copy a colour to a colour pot in another menu:

- 1 Open the node menu containing the colour pot you want to copy a colour to.
- 2 Click in the colour pot in the node menu.
The colour picker appears.
- 3 Click Pick, then click in the Modular Keyer colour pot containing the sampled colour.
- 4 Click in the node menu colour pot again.

Panning the Schematic

When setting up the pipeline, you may need more space than the visible screen provides. You can pan the schematic to access more space for the pipeline.

To pan the schematic:

- 1 Click Pan, or press and hold the **spacebar**.

- 2 Drag anywhere in the schematic.

Notice that the schematic extends “underneath” the menu area.

Cropping the Key Area

You can create a crop box to limit the area where the key setup is applied.

Using a crop box as you create the key speeds up interactivity, which is especially useful when working at high resolutions. You can also process the composite with a crop box. By setting the crop box to surround just the foreground subject, you can save processing time. Everything outside the crop box will be processed as black on the matte.

The crop box is applied to the Front and Matte branches, but not to the Back branch. With the exception of the GMask node, you can see the crop box as you work in different nodes. When you open the Garbage Mask module, you no longer see a defined crop box. However, once you return to the Modular Keyer, you see the crop box, and can use it as before, regardless of any defined garbage masks.

To use the crop box:

- 1 Press **Esc** to display the image window.
- 2 Click Setup.

The Setup menu appears.

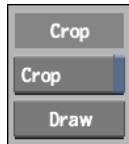

- 3 Click Crop to enable the crop box.
- 4 Click Draw.
- 5 Draw the crop box on the image by selecting a point on the image and dragging the cursor diagonally. Drag the crop box handles to adjust the size and aspect ratio of the box.

NOTE As an alternative to using the Draw button, you can press **Shift+Alt** and draw the crop box. The advantage of using this hot key is that you can redraw the crop box when any other menu is displayed. The Crop button must be enabled to use either of these methods.

- 6 You can now go into any node menu and create the key. You will only see the results of your changes within the crop box.
- 7 If you want to remove the crop box when you have finished creating the key, go back to the Setup menu and disable the Crop button.
If you want to process the clip with the crop box, simply leave the Crop button enabled when you process.

Backing Up the Key Setup

Enable the Backup button in the Setup menu to automatically back up your key setup. When this button is enabled, a backup copy of current key settings is saved in the `_session.Bak` file in the modularKeyer directory.

You can set the amount of time between backups using the Backup Frequency field next to the Backup button. The Backup Frequency is in minutes.

Saving the Key Setup

You can save a key setup that includes the settings in all nodes used to create the key. You can save part of a setup and reload it, or load and save nodes separately. To do this, enable All or Selected (proxies are not saved when using the selection options). You can also load setups using the Replace and Append options.

For Modular Keyer setups that contain RGB Blur and Edge nodes, width and height values are scaled according to the clip resolution of the current session.

To save the key setup:

- 1 Click Setup in the Modular Keyer menu.
The Setup menu appears.



(a) Save option box

- 2 From the Save option box, select All or Selected.
- 3 Click Save. See [Saving Setups and Preferences](#) on page 799.

TIP You can go directly to the Load Setup browser by holding **Alt** when you drag a node to the desktop.

Saving Individual Nodes

You can save and reload certain individual nodes, as well as view menus for them. This applies to Colour Warper, Colour Correct, LUT Editor, Regrain, Degrain, and, as in the following example, GMask nodes.

To save a node:

- 1 Click NodeSetup in the Modular Keyer menu.
The Node Setup menu appears.
- 2 Click Save Node.



Using Nodes

This section describes the nodes you can use to enhance your key, with three exceptions—the 3D Keyer, Gmask, and blend nodes.

To learn about:

Refer to:

The 3D Keyer [3D Keyer](#) on page 1661.

Garbage masks [Garbage Masks](#) on page 1707.

To learn about:

Refer to:

Blend nodes

[Blend Nodes](#) on page 1647.

Before reading this section, you should be familiar with the basic node operations described in [Working with Nodes](#) on page 1612.

2D Histogram Node

Use the 2D histogram node to display the luminance of the matte. You can add this node to any part of the pipeline except the Front pipe of the CBlend node.

To display the matte with the 2D histogram:

- 1 Select Move from the Edit Mode box.



- 2 Select the 2D histogram node.
The histogram appears.
- 3 Press **Esc** to view the image.
The histogram is identical to the histogram in the traditional Keyer.

MasterK Node

Use the MasterK node to access the Master Keyer in order to create a complete key by first extracting colours to generate a matte, and then refining the result. The MasterK node can be added anywhere in the Modular Keyer pipeline.

NOTE The Master Keyer is also available through the Range menu in the Keyer.

The Modular Keyer allows you to bypass the MasterK node by designating either its front, back, matte, or key-in clip input as the result.

To bypass a MasterK node:

- 1 In the Modular Keyer schematic, select a MasterK node.
- 2 In the Bypass box, select the clip you want to pass as the input to the next node.



The MasterK node's operations are bypassed. The clip selected in the Bypass box passes to the next node(s).

The menu in the MasterK node is otherwise identical to the Master Keyer menu available from the Keyer node and from the Keyer module. See [Keyer](#) on page 1545.

RGB Blur Node

Use the RGB Blur node to apply a Gaussian blur to colour images. You can add an RGB Blur node to any part of the pipeline except to the Front and Matte pipes of MBlend nodes and the Matte pipes of CBlend nodes. To blur a matte, use the Blur filter in the Edge node. Both the RGB and Edge node blurs are Gaussian.

NOTE Using this node before the MBlend node on the Matte branch is the equivalent of the KeyIn Filter in the traditional Keyer.

You can animate a blur using the Channel Editor.

To blur a colour image:

- 1 Place the RGB Blur node at the appropriate point in the pipeline. See [Adding Nodes to the Pipeline](#) on page 1614.
- 2 In Move mode, click the RGB Blur node to display the RGB Blur menu.
- 3 If you want the image to be equally blurred horizontally and vertically, click Proportional to enable a proportional blur.



- 4 Set the width and height of the blur. When Proportional is enabled, enter a value in either field. The higher the number, the greater the blur.

NOTE Increasing the blur increases the processing time.

Matte Curves Node

The Matte Curves node displays the same menu that is displayed when you select the Result node—the Matte Curves menu. Use this menu to adjust the luminance of the front and back mattes:

- Use the menu from the Result node to adjust the front and back matte curves for the final composite.
- Use the menu from the Matte Curves node to adjust the matte curves at other parts of the pipeline.

You can add a Matte Curves node to any part of the pipeline except to the CBlend and MBlend pipes. This is because each layer of the blend nodes has its own Matte Curves menu built into it. To learn about adjusting the front

and back mattes of blend node layers, see [Blending the Front and Back Images of a Layer](#) on page 1652.

See [Result Node](#) on page 1643 for instructions on using the Matte Curves menu.

Colour Curves Node

Use the Colour Curves node to adjust the colour in the front, back, or key-in clip. For example, increase or decrease a colour in an image by plotting the colour and adjusting the curve. When you move the first or last keyframe, the other keyframes move by the same amount so that curves are continued from beginning to end.

You can add Colour Curves nodes to any part of the pipeline except to the Front and Matte pipes of MBlend nodes and the Matte pipes of CBlend nodes. This is because these pipes are designed to produce a matte, and the result of the Colour Curves node is a colour image.

The Colour Curves menu is identical to the Colour menu in the traditional Keyer. See [Colour Correcting the Result Clip](#) on page 1592.

Colour Correct Node

Use this node to apply colour corrections to the front, back, or key-in clip using the Colour Corrector.

You can add Colour Correct nodes to any part of the pipeline except to the Front and Matte pipes of MBlend nodes and the Matte pipes of CBlend nodes. This is because these pipes are designed to produce a matte, and the result of the Colour Correct node is a colour image.

When using the Colour Corrector from the Modular Keyer, select a view from the Reference box and View box, while subsequently using the reference clip to compare your result. See [Storing Reference Frames in the Reference Buffer](#) on page 133.

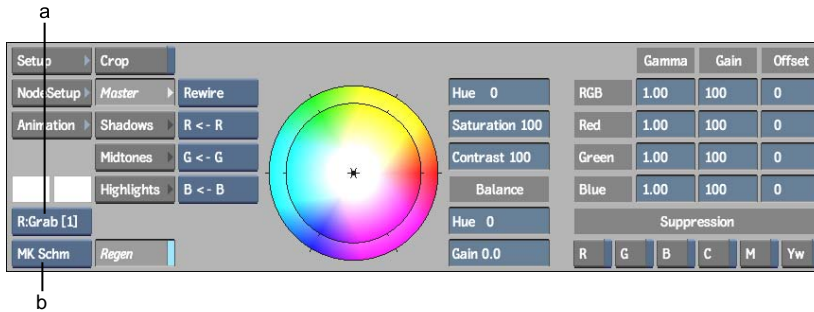

(a) Reference box (b) View box

The View box includes views for Context Point 1 and Context Point 2 while colour correcting the clip. See [Setting a Context Point](#) on page 1624.

To use the Colour Correct node:

- 1 Add a Colour Correct node to the pipeline:
 - If you are colour correcting an entire image, attach a single input to the Front tab.
 - If you are colour correcting a portion of the image, attach the front image to the Front tab and the matte to the Matte tab.
 - If you are colour correcting a composite, attach the front, matte, and back images to the Front, Matte, and Back tabs. This allows you to colour correct the front image only (while viewing the whole composite).

NOTE When you add the Colour Correct node to the Front pipe of the CBlend node, the region to which the colour correction is applied is defined by the Matte pipe. See [Blend Nodes](#) on page 1647 for more information.

- 2 Click the Colour Correct node.
The Colour Corrector menu appears in the menu area. See [Colour Corrector](#) on page 1451.

Colour Warper Node

The Colour Warper node accepts a front, back, and key-in clip as input. Use the Colour Warper node to access the Colour Warper module for colour correcting clips and refining mattes. See [Colour Warper](#) on page 1483.

Difference Matte Node

Use the Difference Matte node to create a matte based on the differences between two clips. You can generate a matte from two clips with the same background but different foreground elements. For example, the first clip could be the blue or green screen shot you want to key, and the second clip could be a “clean plate”—a shot of the blue or green screen with no foreground subject.

This node functions in the same way as the Difference command in the Processing menu. For more on how Difference Matte works, see [Generating a Difference Matte](#) on page 1437.

You can add a Difference Matte node to any part of the pipeline except to the blend node pipes. This is because the nodes in the CBlend and MBlend pipes must have a single input only, and the Difference Matte node always requires two input sources. Typically, you add a Difference Matte node to the beginning of the Matte branch. You can then apply the 2D histogram, Edge tools, garbage mask, and so on, to the resulting matte.

NOTE Since the result of this node is a matte, you cannot use the 3D Keyer node in the Matte branch because the 3D Keyer node uses a key-in clip, not a matte, as its input.

To use the Difference Matte node:

- 1 If needed, add the clip you want to use as the back clip to the schematic. See [Adding Clips to the Pipeline](#) on page 1621.
- 2 Add a Difference Matte node to the schematic. See [Adding Nodes to the Pipeline](#) on page 1614.
- 3 Attach a source to the Front tab and a source to the Back tab of the node.
- 4 Attach the output of the node to the pipeline at the appropriate position. For example, you could set up the node as follows.

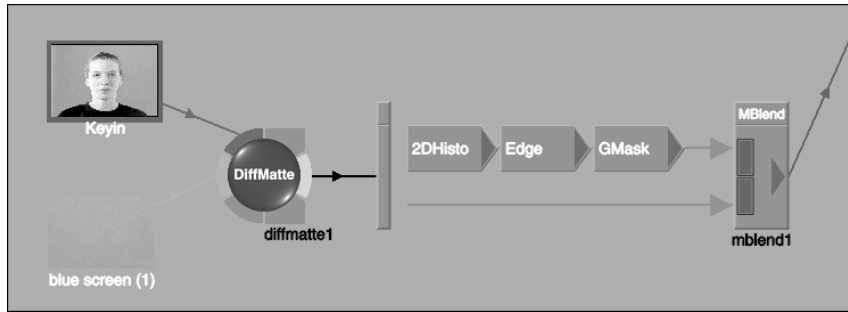

- 5 Click the node to view the Difference Matte menu. For instructions on using this menu, see [Generating a Difference Matte](#) on page 1437.

Edge Node

The Edge menu provides controls to:

- Create a greyscale image composed of the edges in an image. You can apply edge-detection to both colour and monochrome clips.
- Modify the edges of the key. You can apply the Erode, Shrink, and Blur filters to the edges of the matte.

You can add the Edge node to any part of the pipeline except the Front pipe of the CBlend node. The Edge node is not appropriate for this pipe because its result is a matte.

Using Field Mode

Video clips with fast-moving objects can contain artifacts characterized by edge misalignments. These artifacts occur when the odd and even fields are combined into frames. Applying Erode, Blur, or Shrink effects to images containing misalignments does not produce good results. To solve this problem, use Field mode. In Field mode, frames are separated into fields and the effects are applied to the individual fields. The fields are then recombined into frames. This is all done “behind the scenes”—that is, fields are not displayed in the image window.

There are four matte controls in the Edge menu you can use to enhance the edges of the key—Edges, Shrink, Erode, and Blur.

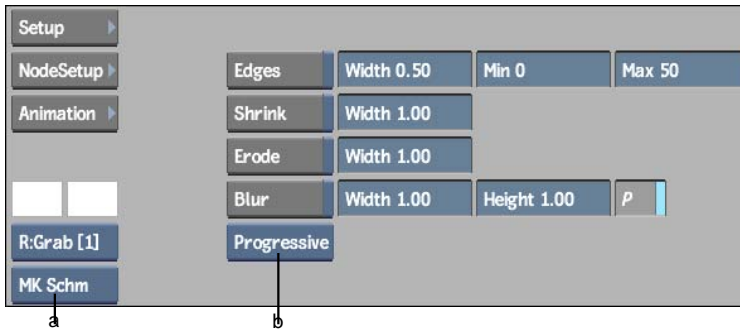

(a) View box (b) Scan Format box

These controls are processed sequentially: Edges is processed first, then Shrink, Erode, and lastly, Blur.

Use:	To:
Edges	<p>Create an image composed of the edges in an image. The resulting greyscale image may be used as a matte or to produce special effects. You can apply the Edges tool to a colour or monochrome clip. This tool has many applications; among the most useful are:</p> <ul style="list-style-type: none"> ■ To delimit a portion of the matte to perform colour corrections on the front clip. ■ To create special effects by using it directly on the front or back clip.
Shrink	<p>Remove pixels from the edge of the matte. It should not be used when the object in the front clip has soft edges such as hair. A negative value expands the matte.</p>
Erode	<p>Blend the light and dark edges of the matte.</p>
Blur	<p>Apply a softening Gaussian blur filter to the edge of the matte.</p>

To transform an image into edges:

- 1 Select CurResult view from the View box.
- 2 Enable Edges.
- 3 Set a value for the edge-detection sensitivity in the Width field to the right of the Edge button. This control affects how the edge-detection algorithm determines whether or not each pixel forms part of the edge.

- 4 Set the Minimum Input Level in the Min field.

The Minimum Input Level sets the start of the range of luminance values in the image. Pixels with luminance values below the Minimum Input Level are mapped to black (0).

- 5 Set the Maximum Input Level in the Max field.

The Maximum Input Level sets the end of the range of luminance values in the image. Pixels with luminance values greater than the Maximum Input Level are mapped to white (255 in 8-bit mode and 4095 in 12-bit mode).

- 6 Enable Shrink.

- 7 Set the width of the edge using the Shrink Width field. Enter a negative Shrink value to expand the border, and therefore widen the edge. Enter a positive Shrink value to decrease the width of the edge.



The edge before adjusting the width using the Shrink Width field

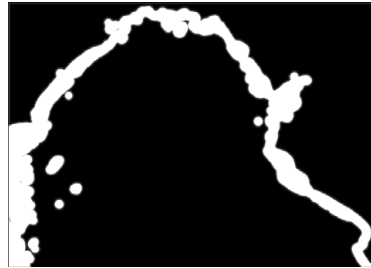

The edge after adjusting the width using the Shrink Width field

To shrink the edge of the matte:

- 1 Select CurResult view from the View box.
- 2 Enable Shrink.
- 3 Set a value in the Width field next to the Shrink button.

This value specifies the width of the border, in number of pixels, that is removed from the edge of the matte.



The matte before applying the Shrink filter



The matte after applying a shrink width value of 1.00

To erode the edge of the matte:

- 1 Select CurResult view from the View box.
- 2 Enable Erode.
- 3 Set a value in the Erode Width field.

This value specifies the width of the matte border, in number of pixels, that will be softened.

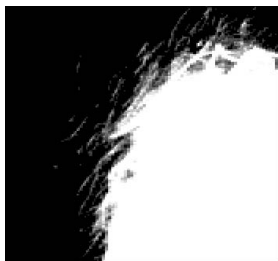

The matte before applying the erode filter

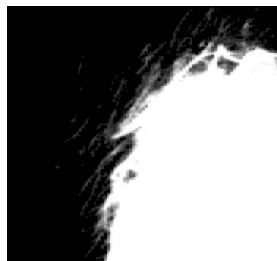

The matte after setting the erode width value to 1.00

To blur the edge of the matte:

- 1 Select CurResult view from the View box.
- 2 Enable Blur.
- 3 If you want the image to be equally blurred horizontally and vertically, click P to enable a proportional blur.
- 4 Set the width and height of the blur. When P is enabled, enter a value in either field. The higher the number, the greater the blur.



The matte before applying a blur

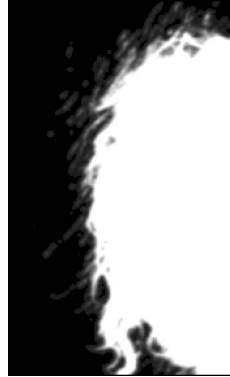

The matte after setting the blur width and height values to 1.00

Degrain and Regrain Nodes

You can use the Degrain node to remove grain from any clip in the pipeline. For example, degrain the KeyIn clip by using a Degrain node at the beginning of the Matte branch to make it easier to extract the matte. Similarly, add the Regrain node to the pipeline to add grain to an image. Keep in mind the following when working with Degrain and Regrain nodes:

- You can add the Degrain node to any part of the processing pipeline.
- You can add the Regrain node to any part of the pipeline except to the Front and Matte pipes of MBlend nodes and the Matte pipes of CBlend

nodes. This is because these pipes are designed to produce a matte, and the result of the Regrain node is a colour image.

- You can go directly to the Load Setup browser by holding **Alt** when you drag a node to the desktop.

The Degrain and Regrain menus in the Modular Keyer contain the same set of controls as the Degrain and Regrain menus accessed from the Processing menu on the desktop (only the menu layout is slightly different). See [Adding and Removing Film Grain](#) on page 773.

Logic Op Node

Use the Logic Op node to generate a clip whose luma (brightness) values are calculated according to the luma values of two source clips. For example, you can add, subtract, or multiply the luma values of corresponding pixels on two clips to create the result clip.

This node functions in the same way as the Logic Ops command in the Processing menu. See [Using Logical Operations](#) on page 1433.

You can add a Logic Op node to any part of the pipeline except to the blend node pipes. This is because the nodes in the CBlend and MBlend pipes must have a single input only, and the Logic Op node always requires two input sources.

To use the Logic Op node:

- 1 If needed, add a second clip to the schematic. See [Adding Clips to the Pipeline](#) on page 1621.
- 2 Add a Logic Op node to the schematic. See [Adding Nodes to the Pipeline](#) on page 1614.
- 3 Attach a source to the Front tab and a source to the Back tab of the node.
- 4 Attach the output of the node to the pipeline at the appropriate position.
- 5 Click the node to view the Logic Op menu. See [Using Logical Operations](#) on page 1433.

Luminance Key Node

The Luminance Key node creates a matte based on the luminance of an image. A front clip can be connected to the Luminance Key node and will process a result clip that can be used as a matte. In the Modular Keyer, this node can be placed only on a matte branch (blue). See [Luminance Key Node](#) on page 1642.

LUT Editor Node

When you import or export Cineon or DPX files, a LUT Editor node is appended to the Import or Export node. A LUT converts logarithmic images to linear images, or linear images to logarithmic images, while maintaining colour accuracy.

When you import or export clips, default LUT parameters are used and the direction of the conversion is detected automatically. Use the LUT Editor to modify these default settings interactively or to import an existing LUT. You can also export a LUT from the LUT Editor. See [Accessing the LUT Editor](#) on page 745.

Monochrome Node

The Monochrome node generates a monochrome copy of the front clip. Use the Channel box to select the monochrome channel for the clip.

Negative Node

The Negative node generates the negative of a source image. The colour values of each pixel in the source image are inverted to produce the negative image. In the Modular Keyer, this is mainly used to invert the matte.

You can add a Negative node to any part of the processing pipeline.

To use the Negative node:

- 1 Add a Negative node to the schematic.
- 2 Switch to Parent edit mode.
- 3 Connect a source to its Front tab.
- 4 Connect the output to the input tab of the next node on the branch.

Result Node

The Result node is the last node in the pipeline—you cannot connect other nodes to its Output tab. Use the Result node to:

- Adjust the luminance curves of the front and back mattes.
- Process the composite.

When you click the Result node, the Matte Curves menu appears. Use this menu to adjust the luminance curves and select processing options.

Adjusting the Front and Matte Luminance Curves

When you create a matte for the front clip, the Modular Keyer automatically creates a matte for the back clip to specify which part of the back clip is used for the composite. By default, the back matte is the inverse of the front matte.

You can adjust the luminance of the front matte and back matte separately in the Matte Curves menu. For example, increase the luminance of the back matte so that more of the back clip shows through at the edges of the key. This creates a better blend at the edges.

To learn how to set the matte curves to create an additive key, see [Creating an Additive Key for CG Images](#) on page 1645.

The following calculation is applied to each pixel of the image to create the composite. The calculation is applied in three passes, one each for the R, G, and B values of the front and back images, and the pixel is given the resulting R, G, and B values.

$$\text{Result} = F * \text{FrontLUT} + B * \text{BackLUT}$$

where:

- F = the R, G and B values of the front image.
- B = the R, G and B values of the back image.
- FrontLUT is the front matte pixel value, re-mapped according to any luminance curve change made in the Matte Curves menu. The value is expressed as a decimal, where, for example,
 - in 8-bit mode, $0 = 0$, $127.5 = 0.5$ and $255 = 1$
 - in 12-bit mode, $0 = 0$, $2047.5 = 0.5$ and $4095 = 1$

- BackLUT is the back matte pixel value, re-mapped according to any luminance curve change made in the Matte Curves menu. The value is expressed as a decimal, as for the FrontLUT.

To adjust the luminance curves:

- 1 In Move mode, click the Result node in the pipeline. Alternatively, if you added a Matte Curves node elsewhere on the pipeline, click the Matte Curves node.

The Matte Curves menu appears.

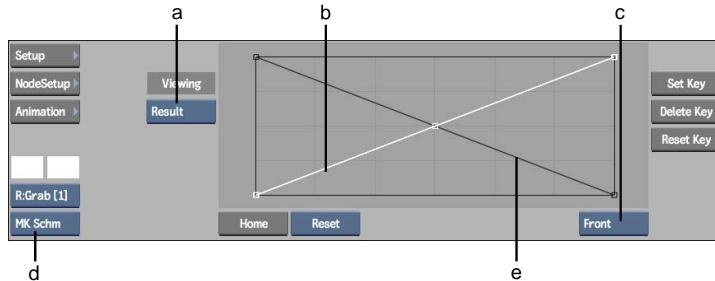

(a) Result box (b) Front matte curve (c) Matte box (d) View box (e) Black matte curve

- 2 Select Result view from the View box. This allows you to use the Result box to view a particular image as you adjust the curve.
- 3 From the Result box, select the image you want to view as you adjust the curves.

Select:	To view:
Result	The composite clip.
Matte	The front matte. You cannot see changes made to the back matte when this view is selected.
Bmatte	The back matte. You cannot see changes made to the front matte when this view is selected.
Comp	The composite with a colour background. The default colour is white. To select a different colour, click the colour swatch below the Edit Mode box. The colour picker appears. See Picking Colours on page 71.

- 4 To adjust the luminance curve for the front matte, select Front from the Matte box. To adjust the back matte curve, select Back. Alternatively, click a curve to select it.

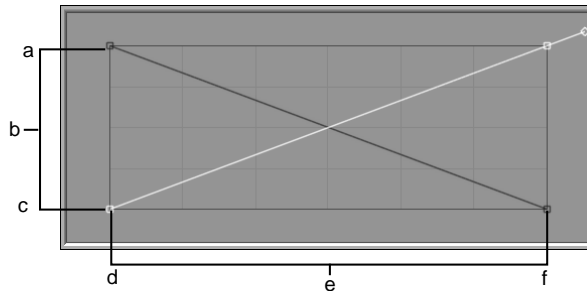

(a) 255 (White) (b) Output (remapping of luminance values) (c) 0 (Black) (d) 0 (Black) (e) Input (current luminance values) (f) 255 (White)

In Move edit mode, click a point to display its tangent handle and drag the handle to adjust the curve. Use other modes in the Edit Mode box (Add, Delete, Break, for example) to further adjust the curve, adding or deleting points, or breaking tangent handles as needed. For more information on using edit modes, see [Animation](#) on page 1963.

Creating an Additive Key for CG Images

Computer graphics clips with a pre-multiplied alpha channel in which the area to be keyed out is black should only use the back matte. This is because the front curve calculation has already been applied to the front image.

To use only the back matte, re-map the entire front matte curve to white (255). This causes the curves calculation to ignore the front matte and use the entire front image. The curves calculation maps all the black areas of the front clip as transparent.

To create an additive key, adjust the front matte curve using the Matte Curves menu in the Result node.

To create an additive key:

- 1 Pull the key and perfect it.
- 2 Select the Result node.
The Matte Curves menu appears.
- 3 Select the front matte curve from the Matte box.

- 4 Drag the vertex at the beginning of the curve from the lower-left corner of the graph to the upper-left corner of the graph.

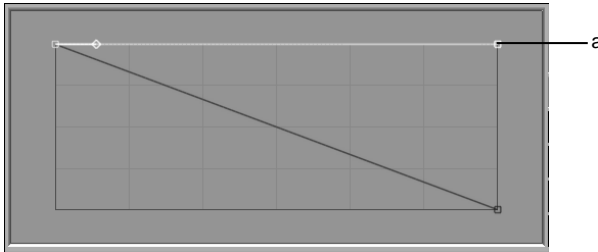

(a) Front matte curve

All pixels in the front matte are mapped to white (255 in 8-bit mode, 4095 in 12-bit mode). The black pixels on the front clip are calculated as transparent.

NOTE This is the equivalent of selecting Punch Back Only in the Setup menu of the traditional Keyer.

Processing Options

You can process the composite clip, the front matte, the back matte, or the composite using a coloured background instead of the back clip.

To process the composite:

- 1 Display the pipeline and select the Result node to display the Matte Curves menu.
- 2 Select the type of clip you want to process in the Result box.

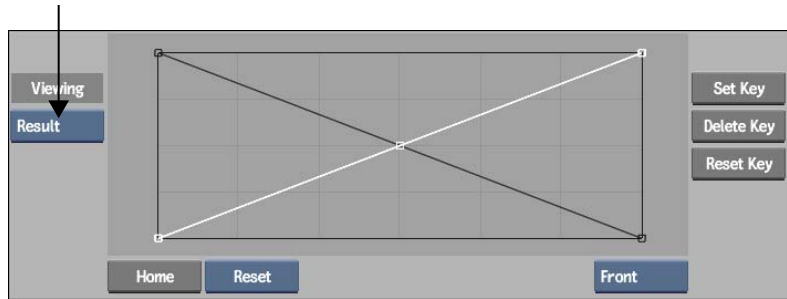

Select:	To process:
Result	The composite clip.
Matte	The front matte.
Bmatte	The back matte.
Comp	The composite with a colour background. The default colour is white. To select a different colour, click the colour swatch to the left of the Result box. The colour picker appears. See Picking Colours on page 71.

- 3 Click Process in the Modular Keyer menu.

NOTE When accessing the Modular Keyer from Action, the Process button is not available; you must return to Action and process it there.

Blend Nodes

Blend nodes include the CBlend (Colour Blend) and MBlend (Matte Blend) nodes.

A blend node is essentially a container that you can use to create a “mini-composite” at different parts of the pipeline. CBlend and MBlend nodes each comprise one or more layers that include the components needed for a composite: a front, matte, and back component. These components are referred to as pipes, and they may contain as many nodes as needed to create the desired image.

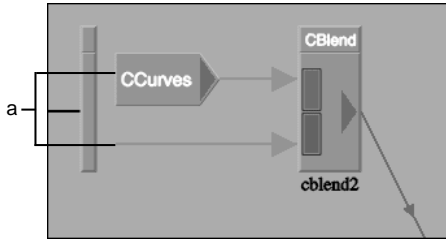

(a) The Front and Matte pipes of the blend node constitute one layer.

The back component is not represented visually as it is applied automatically to the composite.

Nodes on the pipes are processed sequentially, with a single input and single output to and from each node. Therefore, you cannot add multiple input nodes that require several clips (such as the Logic Op node) to pipes. However, some multiple input nodes can operate with only one input source. These are the Gmask, Colour Correct, Degrain, and Regrain nodes. If you add one of these node types to a blend node pipe, it is “converted” to a single-input node.

You can animate the curves in the MatteCurves, CBlend, MBlend, Colour Curves, or Result nodes. See [Animation](#) on page 1963.

Use the CBlend node to create a composite that results in a colour image. Use the MBlend node to create a composite that results in a matte.

CBlend Node

Use CBlend nodes to set up the colour operations you want to perform on a clip. You can:

- Use the Front pipe of a layer to adjust the colour of a clip.
- Use the Matte pipe of a layer to isolate a region of the image to which the colour adjustments will be applied. With no matte, the colour correction is applied to the entire image.
- Blend the front and back images for each layer.
- Create layers of colour corrections for your front clip.

How the CBlend Node Works

The Front pipe of the CBlend node is designed to result in a colour image. This is represented visually by a red box at the right of the Front pipe. You

can place any node on the Front pipe that results in a colour image. These include the Colour Curves, Colour Correct, RGB Blur, Degrain, and Regrain nodes.

The Matte pipe is designed to result in a matte. This is represented by a blue box at the right of the pipe. You can add any node that results in a matte to the Matte pipe, including the 3D Keyer, 2D Histogram, GMask, Edge and Degrain nodes.

The Front and Matte pipes of the CBlend node constitute one layer.

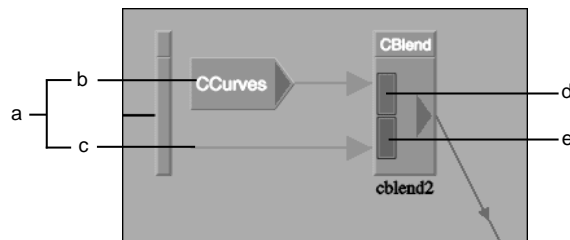

(a) The two pipes constitute one layer (b) Front pipe (c) Matte pipe (d) Red box of Front pipe (e) Blue box of Matte pipe

NOTE The Degrain node results in a colour image; however, it is often useful to place it on the Matte pipe before the 3D Keyer node (which uses a colour image for its input). For this purpose, it can be placed on the Matte pipe.

Components of the composite The two pipes together, along with a back component, constitute one layer. For the first (bottom) layer, the CBlend node uses the source input image for the back component. For example, in the CBlend node on the Front branch of the default pipeline, the Front clip is used for the back component. To learn how subsequent layers are composited, see [Using Several Layers in a Blend Node](#) on page 1654.

MBlend Node

Use the MBlend node to set up the matte operations you want to perform on a clip.

Use the Front pipe of a layer to define the matte, and use the Matte pipe to isolate an area where you want the matte to be applied. For example, use the Matte pipe to isolate an area of the key-in clip and apply a different matte to that area.

NOTE When using the Matte pipe for this purpose, you would create a second layer and place the overall matte in the bottom layer and the second, localized matte in the upper layer. This is because layers are processed from the bottom up. See [Using Several Layers in a Blend Node](#) on page 1654.

When there are no nodes on the Matte pipe, the matte is applied to the entire image.

As with the CBlend node, you can blend the front and back images for each layer and create several layers of mattes.

How the MBlend Node Works

The Front and Matte pipes of the MBlend node are both designed to result in a matte. This is represented visually by a blue box at the right of the Front and Matte pipes. You can place any node on the Front and Matte pipes that results in a matte, including the 3D Keyer, 2D Histogram, GMask, Edge and Degrain nodes.

NOTE The Degrain node results in a colour image; however, it is often useful to place it on the Matte pipe before the 3D Keyer node (which uses a colour image for its input). For this reason, it can be placed on the Matte pipe.

The Front and Matte pipes of the MBlend node constitute one layer.



(a) One layer (b) Front pipe (c) Matte pipe (d) Blue box of Front pipe (e) Blue box of Matte pipe

Components of the composite The two pipes together, along with a back component, constitute one layer. For the first (bottom) layer, the MBlend node uses a pure black image for the back component. To learn how subsequent layers are composited, see [Using Several Layers in a Blend Node](#) on page 1654.

Adding a Matte to a Blend Node

Add a matte to the Matte pipe of the CBlend and MBlend nodes to limit the area on the image where the colour correction or matte will be applied.

You can use any matte operation in the Matte pipe—add any combination of nodes that you would want to use to isolate an area of the front image. For example, you could add a garbage mask node to the Matte pipe of the CBlend node.

To add a matte to a blend node:

- 1 Select Move mode, and select the node in the bar.



- 2 Drag the node to the Matte pipe. Release the cursor.
The node is added to the Matte pipe.

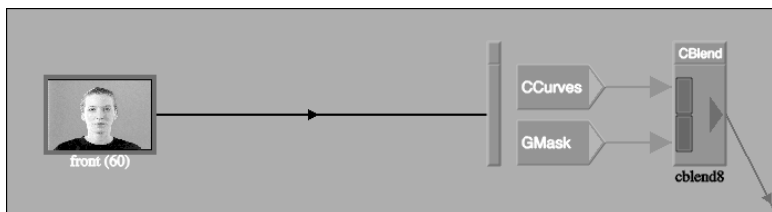

- 3 Use the node menu to create the matte.
- 4 Add other nodes you want to use to refine the matte.

Blending the Front and Back Images of a Layer

There are two different methods you can use to blend the front and back images of a layer: Basic Blend and Curves Blend.

Basic Blend is appropriate for layers that do not have a matte component. It allows you to add the front and back images, and adjust the colour and opacity of the result image. In effect, since you are using the entire front image, the back image does not influence the result.

NOTE Basic Blend is only available for MBlend nodes. It would not be useful to blend colour images in a composite in this way.

Curves Blend is suitable for layers that have a matte component. It allows you to use front and back matte curves to adjust the luminance of the front and back mattes, and also perform logical operations on the front and back images.

The two methods are mutually exclusive—you can set the blending in both the Basic Blend and Curves Blend menus, but it is the menu that is displayed that takes effect.

Basic Blend

Use Basic Blend to adjust the opacity and colour of an MBlend layer that has no matte component. This results in adding a second defined layer to the first one. You can control the opacity of the second layer.

NOTE You can also use Basic Blend when you have defined a matte in the Matte pipe. In this case, the blending is applied to the defined matte area only, rather than the entire front image.

To use Basic Blend:

- 1 Select the MBlend layer by clicking one of the blue boxes to the right of the layer.
The MBlend menu appears and the name of the layer you selected appears in the Layer Name field.

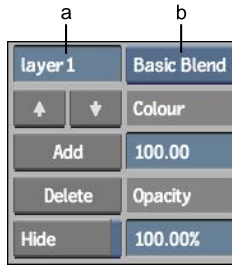

(a) Layer Name field (b) Blend box

By default, if the layer does not have a matte component (that is, there are no nodes in the Matte pipe), the Basic Blend option is selected in the Blend box, and the Basic Blend controls are displayed at the right of the menu.

NOTE If Curves Blend was previously selected, then it is displayed. To display Basic Blend, select it from the Blend box.

- 2 Display the Current Result view. This displays the result for the entire blend node.
- 3 Set the colour of the layer in the Colour field. A value of 100 sets the layer as white, a value of 0 sets it as black, and values in between give it a shade of grey.
- 4 Set the opacity of the layer in the Opacity field. A value of 100 makes the layer completely opaque, and a value of 0 makes it completely transparent.

Curves Blend

Use Curves Blend to adjust the blending of the front and back images of a CBlend or MBlend node layer that has a matte component.

To use Curves Blend:

- 1 Select the CBlend or MBlend layer by clicking the red or blue box to the right of the layer.
The CBlend or MBlend menu appears and the name of the layer you selected appears in the Layer Name field.

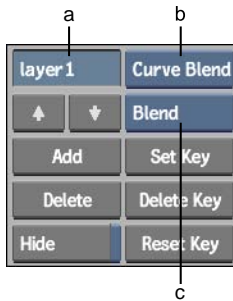

(a) Layer Name field (b) Blend box (c) Logic Ops box

For MBlend nodes, if the layer has a matte component (that is, there are nodes in the Matte pipe), the Curves Blend option is selected in the Blend box and the Matte Curves graph is displayed at the right of the menu.

NOTE If Basic Blend was previously selected, then it is displayed. To display Curves Blend, select it from the Blend box.

- 2 Display the Current Result view.
This displays the result for the entire blend node.
- 3 To perform a logical operation on the front and back images, select one from the Logic Ops box.
- 4 Adjust the front and back matte curves as needed. See [Adjusting the Front and Matte Luminance Curves](#) on page 1643.

Using Several Layers in a Blend Node

You can use up to four layers in blend nodes to create the composite. Using layers, you can avoid doing multiple passes on the same composite.

Layers are processed upwards from the bottom layer. In other words, the uppermost layer will appear on top of the next layer, and so on.

The back component of the lowest layer is a pure black image (for MBlend nodes) and the node input image (for CBlend nodes). For additional layers, however, the back component is different. On both CBlend and MBlend nodes, the result image of the lowest layer is fed into the next highest layer to serve as its back component. Likewise, the result image of this layer is fed into the next highest layer where it serves as that layer's back component, and so on.

NOTE The Current Layer proxy does not display the current layer using the result of the previous layer, as described above. Instead, it displays the layer as if the back clip were a black image (for MBlend nodes) or the front image (for CBlend nodes).

You can change the order of the layers using the Priority Editor.

To create a new layer:

- 1 Select the blend node by clicking anywhere in the rectangular box at its right end.

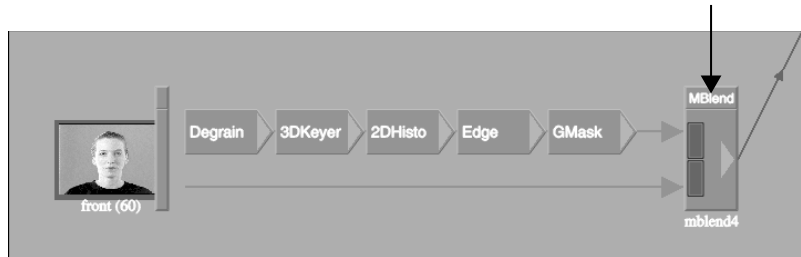

The node is highlighted and the Blend Node menu appears.



(a) Layer Name field (b) Add button

- 2 Click Add to create the new layer.
A new layer is added to the blend node, above the previous layer. The default name for the new layer is layer2.
- 3 Add nodes to the layer as needed, as described in [Adding Nodes to the Pipeline](#) on page 1614.
A simple, two-layer MBlend node is shown as follows.

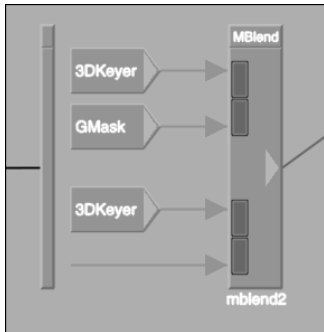

To change the order of the layers:

- 1 Select a layer by clicking either the red or blue box to the right of the pipes.

The selected layer's name appears in the Layer Name field.

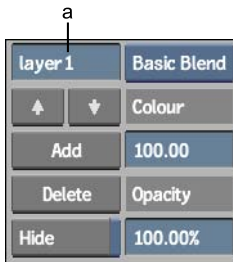

(a) Layer Name field

- 2 Click the ▲ button to move the selected layer up a layer, or the ▼ button to move it down a layer.

Renaming Layers

If you wish, rename layers to identify them more easily.

To rename a layer:

- 1 Select the layer by clicking on the red or blue box to the right of the layer.
- 2 Click the Layer Name field in the blend node menu.

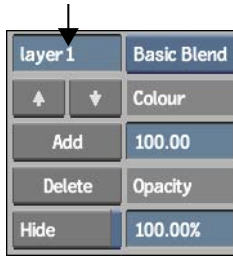

The on-screen keyboard appears.

- 3 Press **Esc** to remove the previous name and type a new name.
- 4 Press **Enter** to save the name.

Bypassing Pipes

On blend nodes, you have the option of inputting a source image from another node on the pipeline, effectively bypassing the pipes. For example, suppose you want to use the key-in clip matte in a colour correction in the Matte pipe of the CBlend node. Instead of copying all the nodes in the Front pipe of the MBlend node, you could just add a branch from the end of the MBlend Front pipe to the blue box on the CBlend node, as shown here.

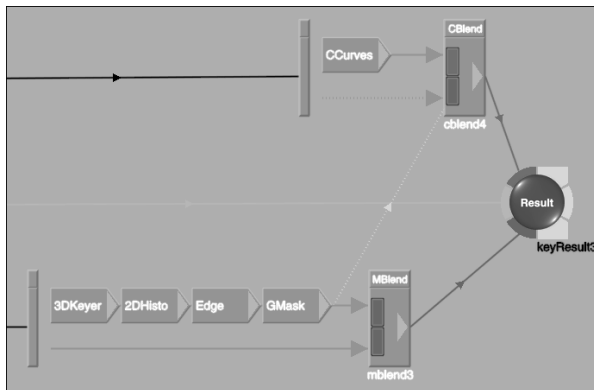

When attaching an alternate input source to a Matte pipe, you should use a matte image. If you use a colour image, it will be converted to greyscale.

For instructions on drawing the branch, see [Adding Nodes to the Pipeline](#) on page 1614.

NOTE To do this, you cannot have any nodes on the pipe receiving an alternate input source.

Animation in the Modular Keyer

In the Modular Keyer, you typically create animations for garbage masks, key elements, and blue screen colour:

- To follow a moving element that you want to remove from the matte, see [Animating Garbage Masks](#) on page 1728.
- To animate the tolerance, softness, and patch ranges in a clip, see [Animating Key Elements](#) on page 1700.
- To animate saturation in the Colour Corrector, see [Creating Animations](#) on page 1971.

Nodes Placement Table

Most nodes can be placed anywhere on the pipeline. There are a few exceptions when it comes to the pipes of blend nodes. The function of a particular node is not possible on some pipes because of the way the pipes operate. See [Blend Nodes](#) on page 1647.

The following table lists the locations in the processing pipeline where you can place the various nodes of the Modular Keyer:

Node	CBlend Front Pipe	CBlend Matte Pipe	MBlend Front Pipe	MBlend Matte Pipe	Other Pipeline Parts
2D Histogram		x	x	x	x
3D Keyer		x	x	x	x
MasterK	x	x	x	x	x
CBlend					x
Colour Correct	x				x
Colour Curves	x				x

Node	CBlend Front Pipe	CBlend Matte Pipe	MBlend Front Pipe	Mblend Matte Pipe	Other Pipeline Parts
Colour Warper	x	x	x	x	x
Degrain	x	x	x	x	x
Difference Matte					x
Edge		x	x	x	x
GMask		x	x	x	x
Logic Op					x
Matte Curves					x
Monochrome	x	x	x	x	x
LUT Editor	x	x	x	x	x
MBlend					x
Negative	x	x	x	x	x
Regrain	x				x
RGB Blur	x				x

NOTE The Result node is not included in this table because you cannot attach anything to it downstream. It can only reside at the end of the pipeline.

Topics in this chapter:

- [About the 3D Keyer](#) on page 1661
- [Accessing the 3D Keyer](#) on page 1662
- [Creating a Precise Key](#) on page 1665
- [Mastering the RGB Viewer](#) on page 1681
- [Animating Key Elements](#) on page 1700
- [More Keying Techniques](#) on page 1703
- [Setting 3D Keyer Preferences](#) on page 1706

About the 3D Keyer

Like traditional keying, the 3D Keyer node in the Modular Keyer is used to select a range of colours to key out, such as the blue or green background in a clip. In the 3D Keyer, however, this range of colours is represented visually in an RGB viewer. You can use the RGB viewer to analyse the colour areas in a clip, and then refine the key with increased accuracy.

The 3D Keyer can be used for many purposes other than pulling a key from the key-in clip. For example, in the Modular Keyer, you could use the 3D Keyer node in the Matte pipe of the CBlend node to isolate a region of the front clip to which you want to apply a particular colour correction.

NOTE It is recommended that you be familiar with the use and terminology associated with the Modular Keyer before you use the 3D Keyer. See [Modular Keyer](#) on page 1603.

3D Keying Workflow

The following table shows the recommended workflow for the 3D Keyer.

Step:	Refer to:
1. Open the Modular Keyer, select the clips, and then open the 3D Keyer.	Accessing the 3D Keyer on page 1662.
2. Sample for tolerance.	Setting the Tolerance on page 1666.
3. Sample for softness.	Setting the Softness on page 1670.
4. Minimize the noise in softened areas.	Removing Noise from Softened Areas on page 1673.
5. Remove grey areas from the key using negative sampling and patches, garbage masks, or RGB colour and softness adjustment.	Removing Grey Areas in the Key on page 1677, Garbage Masks on page 1707, Techniques for Adjusting Softness on page 1703.
6. Adjust the luminance of the key.	2D Histogram Node on page 1630.
7. Adjust the edges of the key.	Edge Node on page 1636.
8. Remove colour spill.	Colour Curves Node on page 1633.
9. Adjust front and back matte curves.	Result Node on page 1643.
10. Process the clip.	Processing Options on page 1646.

Accessing the 3D Keyer

You access the 3D Keyer from the processing pipeline of the Modular Keyer.

NOTE For information on accessing the Modular Keyer from Action, see [Accessing the Modular Keyer from Action](#) on page 2152.

To access the 3D Keyer:

- 1 In the Main menu, click Effects.
- 2 In the Effects menu, click Modular Keyer.
- 3 Select a front clip, a back clip, and a key-in clip.
The Modular Keyer schematic is displayed at the top of the screen.

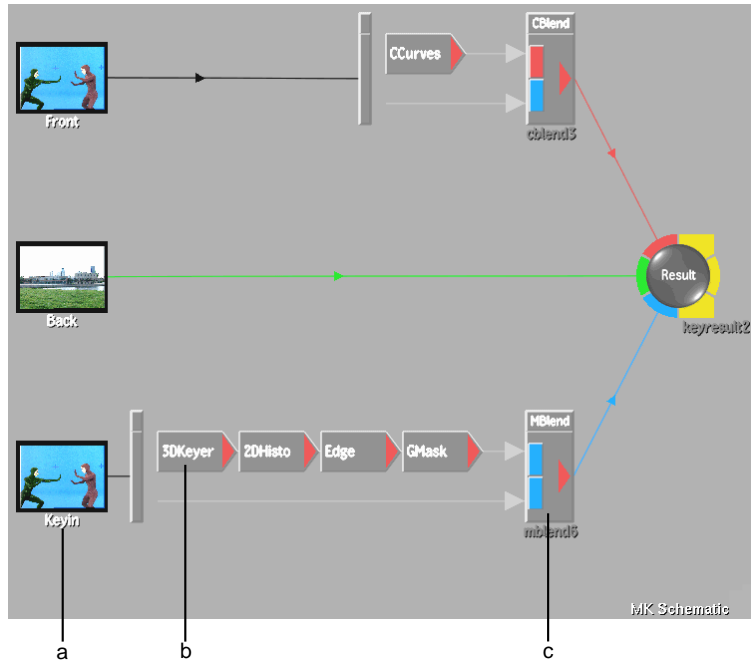

(a) Matte branch (b) 3DKeyer node (c) MBlend node

- 4 Click the 3DKeyer node.
The 3D Keyer menu appears.
- 5 From the Selection box, select Selected.

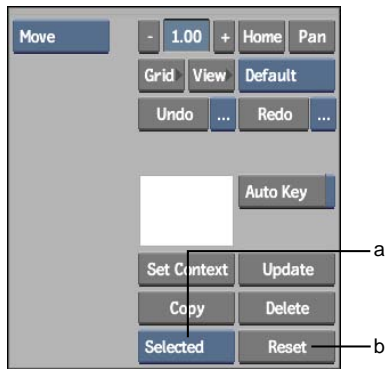

(a) Selection box (b) Reset button

- 6 Click Reset.
- 7 From the View box, select CurResult (or press **F4**) to view the input image for the 3D Keyer. When using the default processing pipeline in the Modular Keyer, this is the KeyIn clip.



The image window showing the KeyIn clip and the RGB viewer appears.

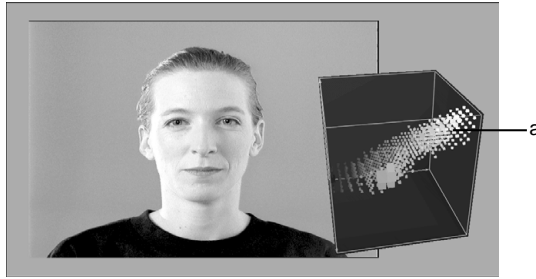

(a) RGB viewer

Creating a Precise Key

This section describes the tools you use to create a precise key with the 3D Keyer. You can learn other techniques for perfecting your key in [More Keying Techniques](#) on page 1703.

The 3D Keyer node can be placed anywhere in the Modular Keyer processing pipeline except the Front pipe of the CBlend node. This is because the purpose of the CBlend Front pipe is to colour correct the Front clip, and the result of the 3D Keyer node is a matte.

Using the RGB Viewer

The RGB viewer is a 3D colour model for the key-in clip. Its X, Y, and Z axes represent the red, green, and blue components of the key-in clip's colour space. The cubes of colour show the distribution of all the colours of the key-in clip in RGB colour space. This 3D colour map is referred to as the 3D histogram.

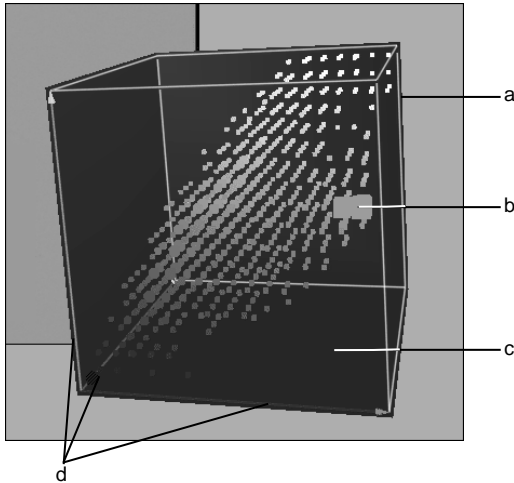

- (a) The colours in the key-in clip are represented by the colour cubes of the 3D histogram
- (b) More prevalent colours are represented by larger cubes
- (c) Black canvas background
- (d) Red, green and blue axes

When you scroll through a clip, the 3D histogram cubes update to display the colour distribution of each frame.

Use the 3D histogram to analyse the colour mapping of the key-in clip and to locate the colours to be keyed out. When you sample for tolerance and softness, the sampled areas are represented as ellipsoids in the RGB viewer. You can manipulate sampled objects in the viewer to fine-tune the key. When you plot a colour to key in the image, its location is plotted in the RGB viewer.

You can turn the display of the histogram and the black canvas background on and off and set options to control their appearance. Change the display any time as you create the key to help you best visualize the contents of your image and work with the RGB viewer. To learn more about controlling the display of the RGB viewer, see [Setting the 3D Histogram Display](#) on page 1682.

Setting the Tolerance

The first step in pulling a key with the 3D Keyer is to set a range of colours to be keyed out from the front clip. This is called the tolerance range. All pixels in the key-in clip in the tolerance range are black in the matte.

To specify the tolerance range, sample the area that you want to key out in the image window. Take one or more samples until you are satisfied with the result. The tolerance range must not be too large or the edge of the composite

will be too hard and the subject in the front clip will appear to be pasted into the back clip.

To set the tolerance range:

- 1 Click Key.

The 3D Key menu appears.

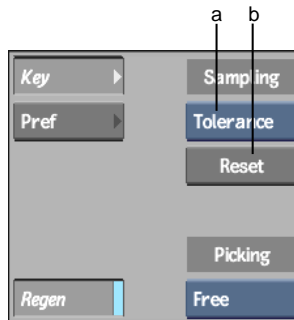

(a) Sampling box (b) Sampling Reset button

- 2 Make sure you are at frame 1. If you move to a different frame while sampling, you will set a second tolerance keyframe (at the new frame) and animate the tolerance.

NOTE To avoid setting keyframes, disable Auto Key.

- 3 In the Sampling box, set the sample type to Tolerance (or press **T**).
- 4 Press **Ctrl** and drag the cursor in the area to be keyed out.
A red rectangle appears. The pixel values in the rectangle are used to define the tolerance range. Notice that the rectangle has a maximum size. This ensures that the result is computed quickly.

NOTE You can also take a sample by clicking the image and dragging the colour picker in the area to be keyed out. All pixel values that the colour picker samples are used to set the tolerance range.

- 5 If needed, add to the tolerance range by sampling several more rectangles. The ellipsoid gets bigger as you add to the tolerance.

NOTE If you are not satisfied with the result of the last sample, click Undo. The last sample you performed is cancelled. To reset the entire tolerance sample, click the Sampling Reset button. To remove the entire sample range at the current frame and start over with a new sample, press **Ctrl+Alt** and drag the cursor in the area to be keyed out.

Viewing the Tolerance Sample

The tolerance sample in the RGB viewer is represented as an ellipsoid by default. The ellipsoid shows you the location, in RGB colour space, of the range of colours included in the sample. All colours in the tolerance ellipsoid are black on the matte.

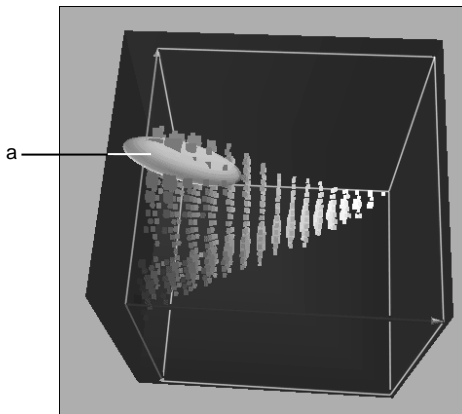

(a) Tolerance ellipsoid

When the histogram is displayed, you can see the location of the sample in relation to the other colours in the image. When it is hidden, you can see the sample more clearly. As you work, show or hide the histogram using the following techniques:

- To display or hide the histogram, press **H**. See [Setting the 3D Histogram Display](#) on page 1682.
- To view the sample more closely, rotate the RGB viewer by pressing **Ctrl** and dragging it. To zoom in on the RGB viewer, press **Shift** and drag inside it from left to right. To move the RGB viewer, press **Alt** and drag it.

Viewing the Convex Hull

The tolerance ellipsoid surrounds the exact colours sampled, which are connected in RGB space to form a 3D convex hull. You can see the convex hull in the ellipsoid by changing the tolerance display.

To view the convex hull:

- 1 Press **H** to remove the histogram.
- 2 In the Tolerance Display box, set the tolerance display to Cloud, which is semi-transparent.

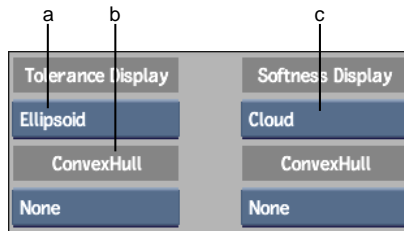

(a) Tolerance Convex Hull box (b) Tolerance Display box (c) Softness Display box

NOTE To learn more about controlling the display of the tolerance sample, see [Changing the Display of Key Elements](#) on page 1684.

- 3 In the Softness Display box, set the softness display to None.

NOTE When you set the tolerance range, the 3D Keyer automatically creates a minimum softness range that is equivalent to the tolerance range. This creates a softness ellipsoid of equal size to the tolerance ellipsoid in the RGB viewer. Sometimes the softness ellipsoid is visible at this point, depending on the way the ellipsoids are displayed.

- 4 Set the Tolerance Convex Hull box to Vert&Surf.
You can now see the convex hull, with vertices indicating the exact colour areas sampled.

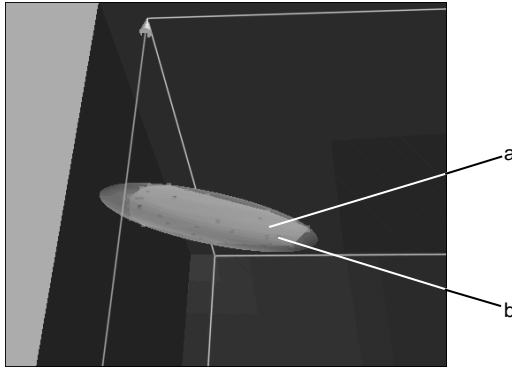

(a) Convex hull (b) Convex hull vertices

The convex hull contains the exact colour values of the tolerance sample, while the ellipsoid represents the actual area in which corresponding pixels will be black in the matte. The 3D Keyer uses the ellipsoid rather than the convex hull to determine the keyed out area because it is much faster to calculate

You can change the shape of the convex hull directly in the RGB viewer to adjust the tolerance. The ellipsoid re-oriens itself according to the new shape. See [Reshaping the Convex Hull](#) on page 1698.

- 5 For the next step, return the softness display to Cloud.

Setting the Softness

The next step is to set a range of colours in the key-in clip to be partially transparent so as to soften the transition between the front and back clips in the composite. This is called the softness range. To specify the softness range, sample the areas to be softened in the image window. The pixels in the key-in clip in the softness range are grey in the matte. The key should have the greatest possible softness value.

As shown in the following steps, the softness range can be set using the RGB or YUV colour models. RGB Softness is the default setting.

To sample for softness:

- 1 Make sure you are at frame 1. If you move to a different frame while sampling, you will set a second softness keyframe (at the new frame) and animate the softness.

NOTE To avoid setting keyframes, disable Auto Key.

- 2 From the Sampling box, select Softness (or press **S**).

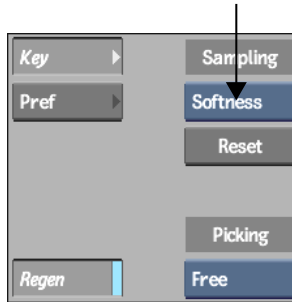

- 3 From the View box, select Front (or press **F1**) to view the input image for the 3D Keyer.
- 4 Identify an area where softness is needed. For example, if the clip consists of a talent in front of a blue or green screen, softness is needed at the edge of the talent to soften the transition between the front and back clips. If the clip contains transparency, softness is needed in the semi-transparent area.
- 5 From the View box, select CurResult (or press **F4**) to monitor the result as softness is applied to the matte while you sample.

TIP You can switch views as you sample the image. CurResult view (**F4**), shows the result of the processing pipeline up to the selected node. To see the Front Source, press **F1**.

- 6 Zoom in to see the image more closely.
- 7 Click in the area you identified.
The cursor changes to a colour picker.
- 8 Drag the colour picker over the area in the image to be softened. Avoid sampling any area that should not be softened, such as the key itself; however, there is no need to avoid areas that have been keyed out. For transparencies, drag the colour picker in the area that you want to be semi-transparent.

A softness ellipsoid appears in the RGB viewer. Notice the tolerance ellipsoid in the softness ellipsoid.

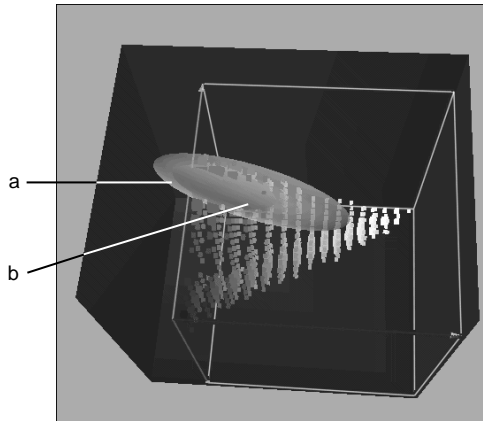

(a) Softness ellipsoid (b) Tolerance ellipsoid

All colours in the softness ellipsoid (except those inside the tolerance ellipsoid) will be grey on the matte. In the softness ellipsoid, the closer a point is to the tolerance ellipsoid, the darker the grey will be. For example, the mid-point between the edge of the tolerance ellipsoid and the edge of the softness ellipsoid is always the same mid-grey.

Notice how the softness ellipsoid increases in size as you sample the edges.

NOTE The softness is rendered interactively on the matte - you see the results immediately. For information on rendering the softness only after releasing the cursor, see [Regen](#) on page 1706.

- 9 Like the tolerance ellipsoid, the softness ellipsoid has a convex hull. To see it clearly, set the Tol Display and Tol ConvexHull display to None, and set the Soft ConvexHull display to Vert&Surf.

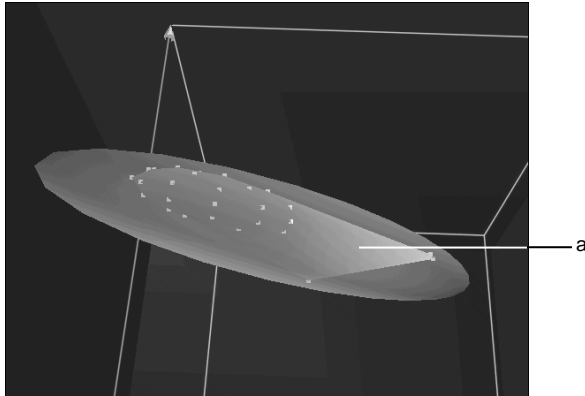

(a) Softness convex hull

- 10 If needed, take another sample elsewhere on the edges or transparency. Each time you sample, the pixels touched by the colour picker contribute to the previously calculated softness range.

NOTE If you are not satisfied with the result of a sample, click Undo. To reset the entire softness sample, click the R button. To remove the entire sample range and start over with a new sample, press **Ctrl+Alt** and drag the cursor in the area to be softened.

- 11 From the View box, select MK Schematic (or press **Esc**) and, in the schematic, click the Result node.
- 12 From the View box, select CurResult (or press **F4**) to view the result. The edges are softened but may be grainy.

Removing Noise from Softened Areas

Once you sample for softness, use the Minimize Noise option to remove grain from the softened areas. Graininess, also known as noise, can occur at the edges of the key, or in the semi-transparent areas such as water or glass.

First, sample an area containing noise. The 3D Keyer analyses the sampled area. Using Minimize Noise, you can then scale the softness in such a way as to minimize the noise in the softened areas.

Minimize Noise is especially useful for semi-transparent areas and edges requiring a lot of softness, such as Smoke, reflection, and shadows.

TIP If the entire clip is grainy, or if you are not satisfied with the results after scaling the softness, consider using another approach. For example, degrain the clip with Degrain before keying with the 3D Keyer. You can add a Degrain node to the beginning of the Matte branch anytime. Additionally, use Minimize Noise on a degrained clip if needed.

To remove noise:

- 1 Sample for softness. See [Setting the Softness](#) on page 1670.
- 2 Zoom in and choose the area you want to analyse. Look for graininess in the softened areas. For transparencies, look for graininess in the semi-transparent areas.
- 3 Press **N** (Noise) and drag a rectangle in the selected area. The 3D Keyer analyses the pixels in the rectangle.
- 4 Select Min Noise from the Softness Scaling box.



(a) Softness Scaling box (b) Scaling field

An arrow appears in the softness ellipsoid, showing the direction in which the softness needs to be increased to reduce graininess in the sampled area.

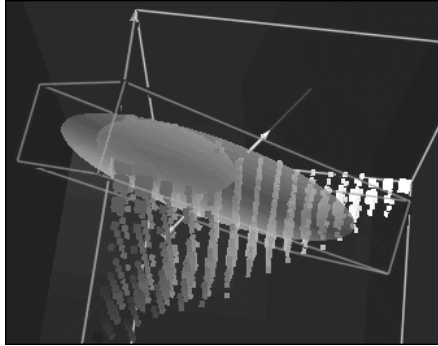

- 5 Increase the softness using one of the following methods:
 - Drag the cursor over the Scaling field to the right. The softness is increased based on the results of the analysis from the grainy region. Observe that the softness ellipsoid is scaled in the direction of the arrow.

NOTE Each time you change the Scaling value, it is returned to 1.00.

- Use a colour value plotted in the image window as the basis for virtual point scaling of softness. To do this, use the **O** hot key to plot a point in the image window, then press **Ctrl+V**, and click and drag in the Player.
- 6 If some edges or areas are still not softened, analyse again in that area and repeat the procedure.
 - 7 Return the Softness Scaling to Prop (proportional scaling).
Alternatively, press **Alt + N** to scale softness based on the Minimize Noise analysis. This hot key is the equivalent of selecting Minimize Noise in the Softness Scaling box, then scaling the softness using the Scaling field.

NOTE When Minimize Noise scaling is selected, it controls the arrow in the RGB viewer. To manually control the arrow, you must return to proportional scaling.

To scale softness using Alt+N:

- 1 Perform a noise analysis.

NOTE **Alt + N** only works if an analysis for the noise has been done.

- 2 Press **Alt + N** and click and hold the cursor anywhere in the image window. Drag the cursor to the left to decrease the noise or to the right to increase it.

The softness is scaled according to the noise analysis. Notice that Minimize Noise appears in the Softness Scaling box as you use the hot key. When you release the cursor, the Softness Scaling option returns to Prop.

TIP For transparencies, use the **V** hot key to remove unwanted grey areas in the matte, then use **Alt+N** to reduce noise in areas you chose to soften (the transparency). Perform the two procedures alternately until you achieve the best result.

Using YUV Softness

If you are not satisfied with the softness result—for example, if graininess still remains in the softened areas, try using YUV Softness. This option calculates the softness according to the YUV colour space.

YUV Softness often creates softened areas that are smoother and is typically useful for shadows and transparencies. However, since it removes more noise, the resulting softness range is less precise.

NOTE You can switch between RGB and YUV Softness and retain their settings.

To use YUV Softness:

- 1 Select YUV from the Softness box.

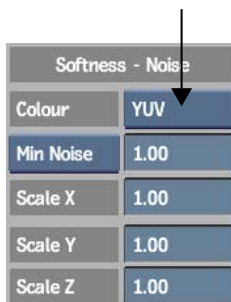

- 2 Sample for softness as described in [Setting the Softness](#) on page 1670.
- 3 Minimize the noise as described in [Removing Noise from Softened Areas](#) on page 1673.

Compare YUV with RGB Softness

Select RGB Softness from the Softness box. The previous RGB Softness range is still in effect. Compare the results with the YUV Softness. Generally, the softness ellipsoid is larger with YUV Softness, as shown in the following example.

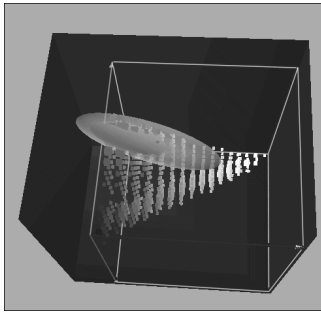

With RGB Softness, the softness ellipsoid is bound by the convex hull

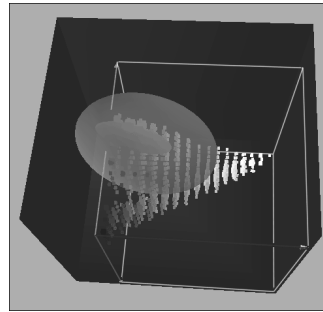

With YUV Softness, the softness ellipsoid is scaled according to the Y component of YUV colour space

If you are satisfied with the result, use YUV Softness. If not, return to RGB softness.

Removing Grey Areas in the Key

Once you have added softness, check to see if there are any grey areas in the key resulting from the setting. If so, there are several techniques to remove the grey areas:

- Perform negative sampling on the areas.
- Use patches.
- Use garbage masks.
- Manipulate the softness element in the RGB viewer.

- Use the Softness fields.

In this section, two methods are shown: using Negative Sampling to refine the softness range, and using the Patch tool to create “selective keys” in the white areas of the matte. To learn other ways to remove unwanted grey areas, see [Techniques for Adjusting Softness](#) on page 1703.

Negative Sampling

This is probably the simplest method of removing greys from the matte. You sample in the unwanted grey area to subtract those colour values from the softness range.

Try this method first to see if it solves the problem. However, if the colour values in the foreground subject are too similar to those at the edges, you may remove too much of the softness.

To perform negative sampling:

- 1 Click CurResult (or press **F4**). Identify the unwanted grey areas in the matte.
- 2 Select Sample Softness from the Sampling box.
- 3 Press **Alt** and click a grey area. Gently drag the cursor over the area. If the negative sampling removed too much of the desired softness or brought back graininess, click Undo and try another method.

Adding a Patch

Patches are another type of sample you can take in the image window. Unlike tolerance and softness, you can specify the colour that a patch sample renders on the matte. Patch samples can be rendered as white, black, or any shade of grey on the matte. You can also set the opacity of a patch.

One use for patches is to remove unwanted grey areas from the matte. Use a patch to isolate a range of colours from those that have been included in the softness range, then set the colour you want the pixels to have on the matte. Sampling a patch to remove grey areas in the key is similar to creating a garbage mask by keying instead of drawing.

You can use up to three different patches in a key.

To sample a patch:

- 1 From the View box, select CurResult (or press **F4**).

- 2 Identify the unwanted grey areas in the matte.
- 3 In the Sampling box, set the sample type to Patch1 (or press **Alt+1**).



- 4 In the Patches box, select Patch 1.

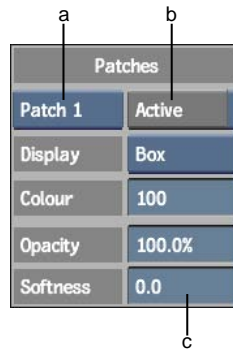

(a) Patches box (b) Active button (c) Patches Softness field

- 5 Enable Active.
- 6 Specify the colour in which you want to render the patch. In this example, make the patch white by setting the P1(Patch 1) Colour to 100 (this is the default value). To render the sampled values as black, enter a value of 0. Use a value between 0 and 100 for any shade of grey.
- 7 Sample the unwanted grey area by dragging the cursor over it.
The grey areas of the matte corresponding to the colour values sampled are changed to white.

All the colour values sampled are included in the patch. Notice the patch in the RGB viewer, represented by a white wireframe box. All colour values in the box will be rendered white on the matte.

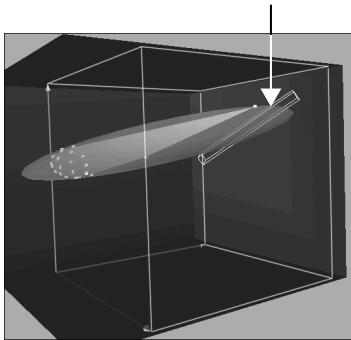

- 8 If necessary, sample again to add to the patch. Watch the edges to make sure they are not affected by the sample.

TIP To remove colour values from the sample, press **Alt** as you sample. To undo a sample, click Undo.

- 9 If needed, soften the edges of the patch by dragging the cursor to the right or left in the Patches Softness field.
A negative softness value softens the edges of the patch inwards from the edge. A positive value softens the edges outwards beyond the edge, adding softened pixel values to the patch.

TIP You can view softness as a red wireframe box when the patch is displayed in Box mode. See [Changing the Patches Display](#) on page 1685.

- 10 If needed, adjust the opacity of the patch using the P1 Opacity field. A value of 100% renders the patch as fully opaque. A value of 0% renders the patch as fully transparent.

The RGB viewer now contains three key elements:

- The tolerance sample (as an ellipsoid)
- The softness sample (as an ellipsoid)
- The patch (as a white wireframe box)

For instructions on completing the key using the basic keying technique, see the sections referred to in [3D Keying Workflow](#) on page 1662.

Mastering the RGB Viewer

The RGB viewer gives you a graphic representation of what you are doing in the key. In this section, learn how to:

- Move, rotate, and zoom in on the RGB viewer.
- Change the display of the 3D histogram and canvas.
- Change the appearance of elements in the RGB viewer.
- Select key elements in the RGB viewer.
- Plot pixels in the image and in the RGB viewer.
- Translate, rotate, and scale key elements in the RGB viewer.
- Reshape the convex hull by manipulating its vertices.

Moving, Rotating, and Zooming in on the RGB Viewer

The RGB viewer represents the 3D colour space of a key-in clip. As you work on the precision of a key, you will want to change the position, orientation, and size of the RGB viewer. Use **Alt**, **Shift**, and **Ctrl** to move, rotate, and zoom in on the RGB viewer.

To:	Do this:
Move the viewer	Alt -click the viewer and drag it.
Zoom in on the viewer	Shift -click the viewer and move the cursor to the left or right.
Rotate the viewer	Ctrl -click the viewer and move the cursor in any direction. By default this rotates the viewer around its centre. Using Rotation Axis options in the Preferences menu, you can also rotate the viewer around a plotted point, or around the centre of the tolerance or softness ellipsoid. This makes it easier to zoom in on specific elements in the viewer.

Resetting the RGB Viewer

To reset the viewer's position, orientation, and size, click Home in the lower-left corner of the Key, Patches, or Preferences menu.

NOTE Other settings, such as resolution or canvas light, are not reset.

Setting the Display of the RGB Viewer

As you work with sampled elements in the RGB viewer, set the display of the 3D histogram, canvas background, and border lines to suit the operation you are performing. For example, when modifying the softness range, consider hiding the 3D histogram to see the softness ellipsoid more clearly.

Setting the 3D Histogram Display

The 3D histogram provides a visual representation of the colours in the key-in clip. It shows how the colours in your clip are distributed in RGB colour space. The most prevalent colours are represented by larger cubes; colours that are less prevalent are represented by smaller cubes.

NOTE The size of the cubes approximates the colour usage in the image, but it is not intended as an exact representation. You can increase the resolution of the cubes using the histogram grid.

Change the display of the histogram using the Preferences menu. To access the Preferences menu, click Pref.



Histogram Shows or hides the histogram. Alternatively, use the **H** hot key.

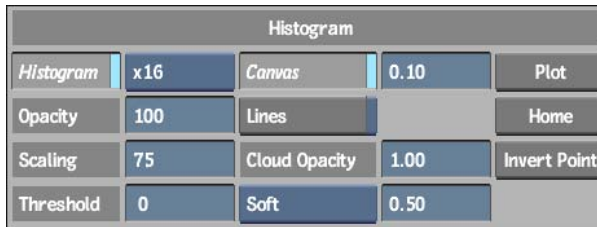

Histogram grid Displays the resolution for the cubes:

- x16 (the default)
- x8 displays fewer and larger cubes
- x32 displays smaller cubes

Opacity field Adjusts the opacity of the cubes. As you adjust the opacity, smaller cubes become transparent at a faster rate than larger ones. The default setting is 100% opacity.

Scaling field Resizes the cubes. Cubes representing less prevalent colours (the smaller cubes) are scaled down more than those representing more prevalent colours. The cube of the most prevalent colour remains the same size (as set in the Histogram Grid box). By increasing the size difference between the colours of greater and lesser prevalence, you can see the main components of the colour space more clearly.

Threshold field Removes the display of colours that are less prevalent in the image. As you increase the threshold, less prevalent colours are increasingly removed from the histogram.

Setting the Canvas Display

The canvas is the black background of the RGB viewer. Control the display of the canvas using the Preferences menu.

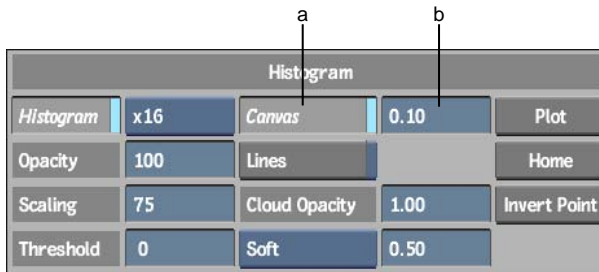

(a) Canvas button (b) Canvas Light field

Canvas button Shows or hides the canvas. Alternatively, use the **C** hot key.

Canvas Light field Sets the lighting in the RGB viewer. The light source emanates from behind the viewer.

Setting the Line Display

You can show or hide a white outline of the borders of the RGB viewer, as well as green wireframe boxes around selected ellipsoids. Show the boxes to quickly identify the selected element, or hide them to reduce “clutter” in the viewer.

To show or hide lines in the RGB viewer:

- 1 Enable or disable the Lines button in the Setup menu (or press **L**).

Changing the Display of Key Elements

You can change the display of the tolerance ellipsoid, softness ellipsoid, and patches as you work on the key to suit the operation you are performing. For example, to adjust the tolerance range after setting the softness, you could set the softness display to wireframe, or remove its display altogether, for a better view of the tolerance. See [Setting the Tolerance](#) on page 1666 and [Setting the Softness](#) on page 1670.

Setting the Tolerance and Softness Ellipsoids

As you sample the tolerance and softness in a key, corresponding key elements appear in the RGB viewer. Set the appearance of the tolerance and softness ellipsoids to make it easier to work with them while refining the precision of the key.

Use the Key menu to set the display of the tolerance and softness in the RGB viewer.

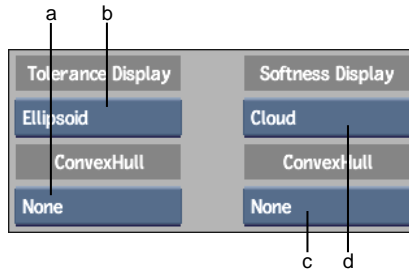

(a) Tolerance Convex Hull box (b) Tolerance Display box (c) Softness Convex Hull box
(d) Softness Display box

Use the Tolerance Display and Softness Display boxes to set the appearance of the tolerance and softness ellipsoids.

Ellipsoid Displays an opaque ellipsoid of the exact colours sampled.

Cloud Displays a semi-transparent grey ellipsoid. You can set the transparency of the ellipsoid using the Cloud Opacity field in the Preferences menu. See [Setting the Cloud Opacity](#) on page 1686.

Wireframe Displays the ellipsoid as a wireframe outline.

None Removes the display of the ellipsoid. Note that when an ellipsoid is not displayed, it still has an effect on the image.

Use the Tolerance Convex Hull and Softness Convex Hull boxes to set the appearance of the tolerance and softness convex hulls.

Vertices Displays only the vertices of the convex hull.

Surface Displays only the surface of the convex hull.

Vert&Surf Displays both the surface and vertices of the convex hull.

None Removes the display of the convex hull.

NOTE Vertices do not appear on keyed elements when Tol Display or Soft Display is set to Ellipsoid (because an ellipsoid is opaque).

Changing the Patches Display

You set the display of each of the three patches individually. In the Patches menu, use the Display boxes to set the display of patches 1, 2 and 3.

Box Displays the patch as a wireframe box.

Surface Displays only the convex hull of the patch.

Box&Surf Displays both the wireframe box and convex hull of the patch.

Cloud Displays the patch as a semi-transparent grey box. You can set the transparency of the box using the Cloud Opacity field in the Preferences menu. See [Setting the Cloud Opacity](#) on page 1686.

None Removes the display of the patch. When a patch is not displayed, it still has an effect on the image.

Setting the Cloud Opacity

You can control the opacity of the Cloud setting of ellipsoids and patches as they appear in the RGB viewer using the Cloud Opacity fields in the Preferences menu.

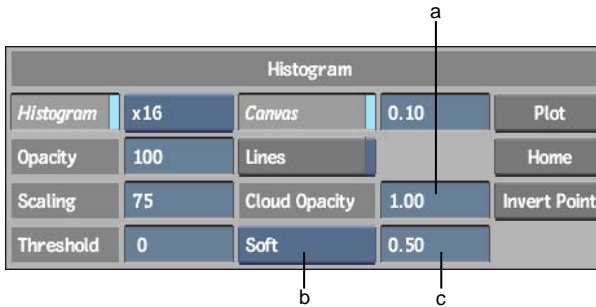

(a) Overall Opacity field (b) Key Element box (c) Individual Opacity field

You can adjust the opacity for all key elements or for individual key elements:

- To set the cloud opacity for all ellipses and patches, use the Overall Opacity field.
- To set the cloud opacity for an individual key element, select the element from the Key Element box, then set the opacity in the Individual Opacity field.

Displaying Plotted Points and Regions

When you plot colour values and ranges of colour values in the key image, you can display or hide the plotted points and regions in the RGB viewer.

To show or hide plotted points:

- 1 Enable or disable the Plot Point button in the Preferences menu (or press **B**).

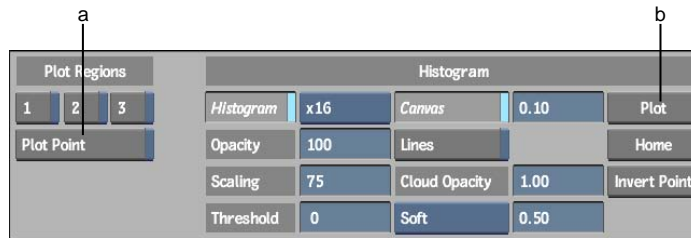

(a) Plot Point button (b) Plot button

NOTE When you plot a colour value, the Plot Point button is automatically enabled to display the colour value in the viewer.

To show or hide Plot Regions 1, 2, or 3:

- 1 Enable or disable the corresponding buttons in the Preferences menu.

Selecting Key Elements in the RGB Viewer

As you translate, scale, and rotate key elements in the RGB viewer, you must select them individually. The 3D Keyer provides two methods for selecting key elements—clicking on them in the viewer or using the Picking box. The Picking box enables precise selection especially when tolerance, softness, and patch elements overlap each other in the RGB viewer.



The Preferences menu contains the Lines button. Use this button to display lines around key elements when they are selected in the viewer. This can make it easier to identify the selected key element.

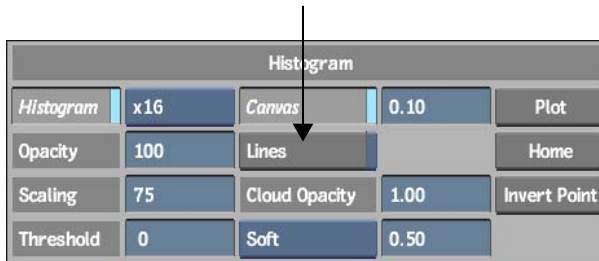

Clicking Key Elements

When you click key elements in the RGB viewer, a directional arrow appears through the selected element. The arrow points in a particular direction according to where you click on the element. See [Controlling Elements with the Directional Arrow](#) on page 1690.

The Picking box must be set to Free to select an element by clicking it. Also, the Softness Scaling must be set to Prop not Minimize Noise (Minimize Noise selects softness and controls the arrow direction).

To select key elements by clicking:

- 1 In the Key menu, select Free from the Picking box and make sure that Prop is selected in the Softness Scaling box.

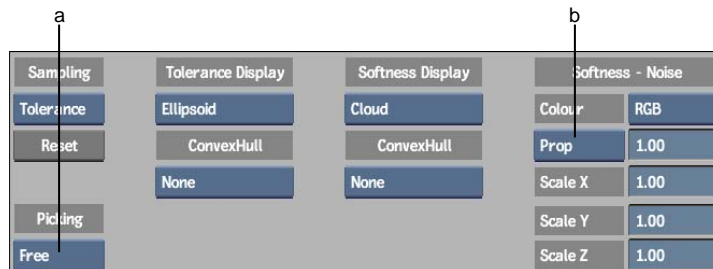

(a) Softness Scaling box (b) Picking box

- 2 Select a key element in the RGB viewer by clicking it.

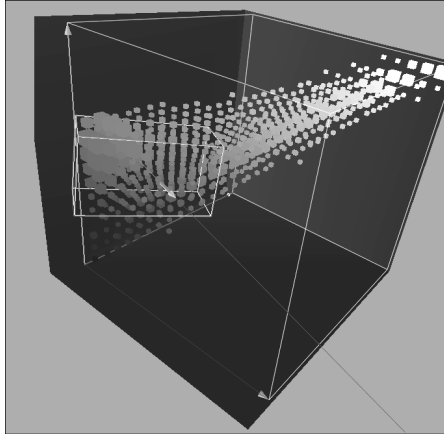

A directional arrow appears through the selected key element and, if the Lines button is enabled, a green wireframe box appears around the selected key element.

- 3 At this point, you are ready to proceed with modifying the selected key element. See [Translating, Scaling, and Rotating Key Elements](#) on page 1696 and [Reshaping the Convex Hull](#) on page 1698.

If you are unable to select the element, the element may be behind or inside another element. You can hide the element that is in the way by setting its display to None. See [Changing the Display of Key Elements](#) on page 1684. Alternatively, use the Picking box to select the element, as described in the next procedure.

Using the Picking Box

When an element is selected with the Picking box, you cannot select other elements in the viewer by clicking on them. This helps prevent other key elements from being selected by accident while you work with a particular key element.

The Picking box is also useful because it allows you to select a key element without changing its current arrow position. For example, if you accidentally click elsewhere in the viewer and lose the selection, and you want to re-select the element without changing the arrow position, use the Picking box.

NOTE When you use the Picking box to select a key element that has not been previously selected, the arrow is not displayed. You must actually click the element to set the arrow direction.

To select key elements using the Picking box:

- 1 In the Key menu, verify that the Softness Scaling is set to Prop (Minimize Noise forces the softness to be selected).
- 2 Select the key element from the Picking box.



If lines are displayed in the viewer, a selected ellipsoid has a green wireframe box around it and patch boxes change from white to green. If the element's arrow direction has been set, the arrow is displayed.

- 3 To display the element's arrow and set its direction, click the element.
At this point, you are ready to proceed with adjusting the range of the selected key element.

Controlling Elements with the Directional Arrow

Each key element (tolerance, softness, and patches) has a directional arrow that passes through its centre point. Use this arrow to indicate the direction in which you want to perform a particular action, such as scaling or translating the element.

- To display an element's arrow, select the element by clicking on it.
- To set the arrow direction manually, click inside the key element anywhere between its centre and the area towards which you want the arrow to point.

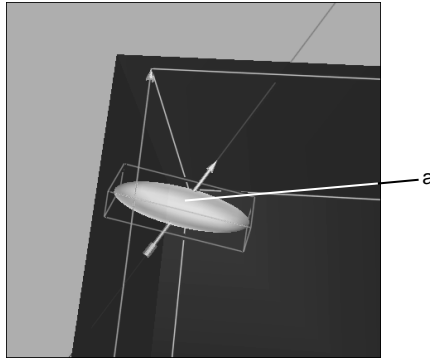

(a) Click in the element to set the arrow direction.

NOTE You can only click on a part of the element's surface that is visible. If necessary, rotate the RGB viewer so that the correct area of the surface is visible.

- To point the arrow towards a plotted point, simply select the element (either by clicking on it or using the Picking box) before plotting. The arrow will automatically point towards the plotted point.
- To reverse the direction of the arrow, click the Reverse Point button in the Key menu.

NOTE When Minimize Noise is enabled, this tool controls the arrow direction. See [Removing Noise from Softened Areas](#) on page 1673.

Plotting Colour Values

You can plot pixels in the key image and view the location of the pixel colour value in the RGB viewer. You can plot a single colour value or a range of colour values. These plotted areas do not affect the key at all—they simply identify colour values in the viewer.

You can plot a colour value to view its location in relation to key elements in the viewer. Additionally, you can employ a number of techniques to modify a key element in relation to a plotted colour value or range of values. For example, you could plot a colour value corresponding to an unwanted grey area in the foreground subject, and then translate or scale the softness ellipsoid such that the colour value is outside the ellipsoid.

Plotting Single Colour Values

Plotting a pixel in the key image sets the exact location of the colour value in the RGB viewer. The colour value is identified by a small, white wireframe cube in the viewer. As an alternative, you can use the Plot tool to select a colour value directly in the viewer by clicking on a 3D histogram cube.

If a key element in the viewer is selected before you plot the colour value, the element's directional arrow moves to point towards that colour. Plotting pixels in this way allows you to quickly refine the matte by translating or scaling a key element with respect to the plotted colour.

To plot a pixel on the key image:

- 1 In the RGB viewer, select the key element that you want to modify in relation to a plotted colour value. For example, click a patch key element. If you have problems selecting the element, see [Selecting Key Elements in the RGB Viewer](#) on page 1687.
- 2 If needed, zoom in on the key image so that you can select a pixel more easily.
- 3 Click Plot (or press **O**).

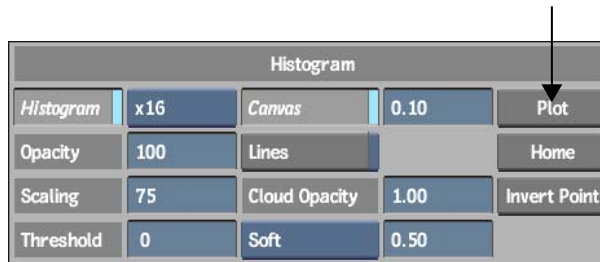

Plot is enabled.

- 4 Click a pixel in the key image. You can also drag the cursor in the image, then release the cursor when the colour picker is over the desired pixel. In the RGB viewer, the colour value of the selected pixel is plotted and the arrow of the selected key element moves to point towards the plotted colour value. If needed, rotate the viewer by pressing **Ctrl** and dragging it to get a better view of the key element with respect to the plotted value.

- 5 Proceed with modifying the selected key element. Using the hot keys, you can move the selected key element to refine the key.

Press:	To:
V-click	Sample pixels where you click in the image. The arrow is re-positioned in the RGB viewer. Drag left or right to scale along this axis.
6 and drag key element	Move the selected key element in the direction of the arrow.
7 and drag key element	Rotate the selected key element in any direction around its centre point.
8 and drag key element	Scale the selected key element proportionally from its centre. Drag left to scale down and right to scale up.
9 and drag key element	Scale the selected key element in the direction of the arrow (non-proportionally) from its centre. Drag left to scale down and right to scale up.
0 and drag key element	Scale the selected key element in the direction of the arrow (non-proportionally), starting from the point on the key element's surface where the back of the arrow remains anchored in place.

As you move the key element away from the plotted pixel, you can see the effect on the key image or the matte.

To select a colour value in the RGB viewer:

- 1 In the RGB viewer, select the key element that you want to modify in relation to a plotted colour value. For example, click a patch key element. If you have problems selecting the element, see [Selecting Key Elements in the RGB Viewer](#) on page 1687.
- 2 Press **H** to display the 3D histogram.
- 3 If needed, zoom in on the viewer or rotate it so that you can select a histogram cube more easily.
- 4 Click Plot (or press **O**).

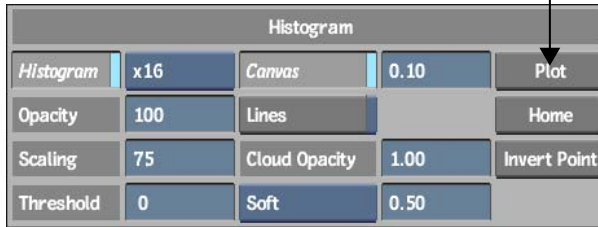

Plot mode is activated and the cursor changes to a colour picker.

- 5 Select a cube in the histogram of the RGB viewer. If needed, drag the colour picker around the viewer until it is pointing to the correct colour value.

The selected cube is surrounded by a white wireframe box and the direction of the key element arrow moves toward the selected cube.

Plotting a Range of Colour Values

When you plot a range of colour values in the image, the resulting plotted region in the RGB viewer appears as a 3D convex hull. You can plot up to three colour ranges in the image. The plotted regions do not in themselves affect the key image in any way.

A plotted region allows you to compare the intersection of a key element with a particular colour range in the image, providing you with yet another alternative for adding precision to your key.

For example, use this tool to plot a colour range that you do not want to be softened. Using the plotting region as the reference, you translate and scale the softness ellipsoid away from the plotted region to ensure the softness precision of the key. Plotted regions also help you to determine whether or not to use a garbage mask. If a colour that you want to soften is the exact colour that you want key out, then you should apply a garbage mask.

To plot a region:

- 1 In the Preferences menu, enable the Plot Regions 1 button.
The display of Plot region 1 is enabled.
- 2 In the Sampling box, select Plot1.



- 3 In the key image, sample one or more pixels using the same methods that you use for sampling tolerance or softness (simply drag in the image, or press **Ctrl** or **Ctrl+Alt**).

A 3D convex hull appears in the RGB viewer.

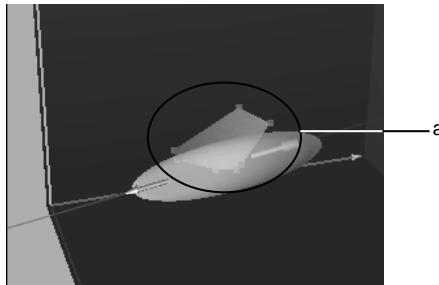

(a) Each vertex contributes to the convex hull that represents the plotted region.

- 4 Continue sampling pixels in the key image until you are finished plotting the region.

Plotting Several Regions You can plot a second and third region, and compare the positions of the convex hulls. To plot a second region, use the procedure described above, selecting Plot 2 from the Sampling box and enabling the Plot Regions 2 button.

For example, sample one plot region in an area of the matte containing unwanted grey areas, and another plot region where the grey area is intentional. You can then observe where the colours of the two regions are

the same (where the plotted regions intersect), and adjust the softness accordingly.

To:	Do this:
Remove the grey areas from the foreground subject.	Move the softness key element away from the plotted region intersection.
Prevent the matte from becoming over softened or transparent.	Use a patch.
Keep part of the key that has the exact colour as the area being softened.	Use a garbage mask.

Translating, Scaling, and Rotating Key Elements

You can fine-tune the key by translating, scaling, or rotating the tolerance ellipsoid, softness ellipsoid, and patches in the RGB viewer. For example, scale the softness ellipsoid in a particular direction to increase the softness. You use the same methods for all three key element types.

To translate or scale an element in a particular direction, you use its arrow to specify the direction. When scaling an element along the axis of the arrow, you have the option of scaling it equally in both directions from its centre, or scaling it only in the forward direction of the arrow. You can also scale an element proportionally in all directions (X, Y and Z directions).

Before performing the following operations, set up the RGB viewer to best display the elements you are working with. Zoom in on the element, decide if you want to show the histogram, and hide elements that are in the way. See [Changing the Display of Key Elements](#) on page 1684.

TIP Display the 3D histogram as you make modifications to see the areas of colour that you are working in. Try reducing the size and opacity of histogram cubes to see more clearly. See [Setting the 3D Histogram Display](#) on page 1682.

To modify the tolerance or softness using these techniques, the ellipsoid must be displayed. The Tol Display or Soft Display must be set to Ellipsoid, Wireframe, or Cloud. Likewise, when reshaping patches, the patch box must be displayed. The box is displayed when the Display is set to Cloud, Box, or Box&Surf.

See [More Keying Techniques](#) on page 1703 to learn ways to apply these techniques in specific situations.

To translate a key element:

- 1 Select the element. See [Selecting Key Elements in the RGB Viewer](#) on page 1687.
- 2 Identify the direction in which you want to translate the element and set the arrow in this direction. You can do this manually. See [Controlling Elements with the Directional Arrow](#) on page 1690.
- 3 Alternatively, you can also plot a pixel on the image or a histogram cube (see [Plotting Single Colour Values](#) on page 1692). When you plot a pixel on the image or a histogram cube, the arrow of the selected key element automatically points towards the plotted pixel.
- 4 Press **6** and drag the cursor in the RGB viewer. Drag to the right to translate the element forward along the arrow axis, or to the left to translate it backward.

To rotate a key element:

- 1 Select the element. See [Selecting Key Elements in the RGB Viewer](#) on page 1687.
- 2 Press **7** and drag the cursor in the key element.
The key element rotates in any direction around its centre point.

To scale a key element proportionally:

- 1 Select the element. See [Selecting Key Elements in the RGB Viewer](#) on page 1687.
- 2 Press **8** on the keyboard and drag in the RGB viewer. Drag to the right to increase its size, or to the left to make it smaller.

To scale a key element from its centre:

- 1 Select the element. See [Selecting Key Elements in the RGB Viewer](#) on page 1687.
- 2 Set the arrow in the desired direction. You can do this manually. See [Controlling Elements with the Directional Arrow](#) on page 1690.
You can also set the arrow by plotting a point on either the image or a histogram cube. When you plot a point on the image or a histogram cube, the arrow of the selected key element automatically points towards the plotted pixel. See [More Keying Techniques](#) on page 1703.

- 3 Press **9** and drag the cursor in the RGB viewer. Drag to the right to scale it larger along the axis of the arrow, and to the left to scale it smaller. The element is scaled equally in the forward and backward directions of the arrow.

To scale a key element in one arrow direction:

- 1 Select the element. See [Selecting Key Elements in the RGB Viewer](#) on page 1687.
- 2 Set the arrow in the desired direction. You can do this manually. See [Controlling Elements with the Directional Arrow](#) on page 1690.
- 3 You can also set the arrow by plotting a point on either the image or a histogram cube. When you plot a point on the image or a histogram cube, the arrow of the selected key element automatically points towards the plotted pixel. See [More Keying Techniques](#) on page 1703.
- 4 Press **0** and drag the cursor in the RGB viewer. Drag to the right to scale it larger in the forward direction of the arrow, or to the left to scale it smaller towards the centre of the element. The element is scaled in the forward direction of the arrow only.

Reshaping the Convex Hull

You can exclude or add specific ranges of colour to a sample by modifying the shape of the convex hull of the softness ellipsoid, tolerance ellipsoid, and patches. You do this by manipulating the vertices on the hull. The ellipsoid or patch box changes shape according to the new shape of the convex hull.

This can be an accurate way of modifying the sampled ranges since you can see the area of RGB colour space in which you are working and because you can plot specific parts of the image and add them to the hull. Also, scaling the ellipsoid using one vertex of the convex hull provides a more precise (localized) result than scaling using the arrow alone (using **0**).

To change the shape of the convex hull, you can add and move vertices, or delete vertices from the convex hull entirely.

Before performing the following operations, set up the RGB viewer to best display the elements you are working with. Zoom in on the element, decide if you want to show the histogram, and hide elements that are in the way.

To reshape the convex hull of the tolerance or softness, the ellipsoid must be displayed. It must be set to Ellipsoid, Wireframe, or Cloud. Likewise, when reshaping patches, the patch box must be displayed. The box is displayed when the Display is set to Cloud, Box, or Box&Surf.

It is best to show the convex hull. Although it is not necessary to perform the operation—unless you are deleting vertices, you can see what you are doing more clearly. See previous sections in this chapter, such as [Changing the Display of Key Elements](#) on page 1684.

To add vertices to the hull and move them:

- 1 Select the key element by clicking it.
- 2 Position the arrow of the selected element in the direction in which you want the ellipsoid or patch to grow or shrink. For example, point the arrow towards colours you want to include in your sample. Alternatively, plot a point to position the arrow. See [Controlling Elements with the Directional Arrow](#) on page 1690.
- 3 Press and hold **V** on the keyboard and click anywhere in the RGB viewer. A vertex is added to the hull at the intersection of the arrow and the edge of the ellipsoid or patch.

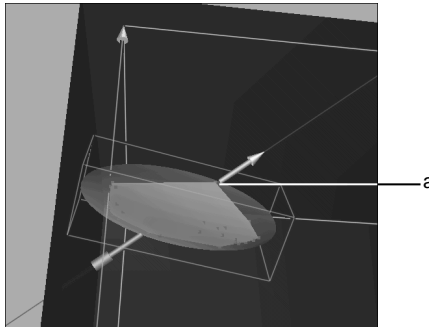

(a) Vertex is added to the hull

NOTE When using **V** in the RGB viewer, you can scale any convex hull (tolerance, softness or patches). If you use **V** in the image window, it will apply to softness only.

- 4 To add colours to the sample, drag the cursor to the right. This moves the vertex in the forward direction of the arrow.

To remove colours from the sample, drag the cursor to the left. This moves the vertex backward towards the centre of the element.

When you are satisfied with the result in the image window, release the cursor.

The hull is reshaped as you move the vertex. If you did not display the convex hull, it is temporarily displayed while you are moving the vertex. The direction of the arrow may change slightly as you move the vertex, but the direction it moves in is always the direction in which the arrow was initially pointing.

NOTE You can release the **V** key and the cursor, then press them again to scale the same vertex. You retain control over the new vertex until you change the position of the arrow.

To remove a vertex from the convex hull:

- 1 Display the convex hull of the key element, including the vertices. See [Changing the Display of Key Elements](#) on page 1684.

NOTE You do not have to select a key element to delete a vertex from its convex hull.

- 2 If necessary, zoom in on the element to distinguish the vertices more clearly.
- 3 Press and hold the - sign on the keypad (not the one on the keyboard) and click on the vertex that you want to remove.
See [Techniques for Adjusting Softness](#) on page 1703.

Animating Key Elements

In a live-action clip, you can animate the tolerance, softness, and patch ranges as the subject in the clip moves. You can also animate the colour, opacity, and softness of patches.

Animating the Range of Key Elements

You animate the tolerance, softness, and patch ranges by changing the range at different frames. In the Channel Editor, range changes appear in the Shape channel. You can set a Shape keyframe by:

- Adding or subtracting pixel values from the range by sampling again in the image.
- Adjusting the key elements in the RGB viewer. All transformations made to a key element are applied to its Shape keyframe, including translation, rotation, scaling, and noise analysis.
- Changing the values in the Softness Scaling X, Y, and Z fields.

If you display the convex hull while animating a key element, the convex hull fills the ellipsoid in between keyframes. The sample is recreated to fill the ellipsoid on interpolated frames. This ensures the smoothest possible transition between keyframes.

To display the Channel Editor, click the Animation button. For animation basics, see [Animation](#) on page 1963.

NOTE To animate key elements, enable Auto Key.

Shape Keyframes

The shape of ellipsoids and patches is defined by their translation, rotation, and scaling values, so the Shape keyframe is actually composed of multiple parameters. The Y value in the Channel Editor does not have the same significance as it does for a single parameter (for example, opacity). Instead, the Y value is composed of sequential numbers that represent keyframes that have been set. Each consecutive keyframe is assigned a sequential Y value: the first keyframe has a Y value of 1, the second has a Y value of 2, and so on. Although the Y value does not represent a single value, you can still adjust the curve to tweak the shape.

To animate the range of a key element:

- 1 Perfect the key at frame 1.
- 2 Enable Auto Key.
- 3 Scroll to other frames and, where necessary, adjust the range using any of the techniques provided in this chapter.

Keyframes are added at each frame where you change the tolerance, softness, or patch range.

NOTE When you set a tolerance keyframe, a softness keyframe is also set. This is because the softness range is always at least as large as the tolerance range. When you set the tolerance range, the 3D Keyer automatically creates a minimum softness range that is equivalent to the tolerance range. When you adjust the tolerance, the softness range is also adjusted to accommodate the change.

- 4 Optionally, tweak the animation by adjusting the shape curve in the Channel Editor. The image updates as you make changes.

Changing the Interpolation

Parameter values in between keyframes are interpolated. Change the type of interpolation using the Channel Editor.

The default interpolation for the shape curve is Hermite, which creates a smooth transition between keyframes. If your clip has a very sudden change in the colour values (for example, if a light was switched on at a particular frame), use Constant interpolation between the two keyframes where the change occurs. See [Setting Interpolation](#) on page 1980.

Animating the Patch Parameters

Animate the colour, softness, and opacity of patches by changing the values in the Patches menu. Channels for each of these parameters are located in the Patch folders of the Channel Editor.

To animate the patch parameters:

- 1 Go to the appropriate frame.
- 2 Enable Auto Key.
- 3 Change the values in the Colour, Opacity or Softness fields as needed.

Resetting a Channel

There are two ways to reset a channel:

- Using the R (Reset) button next to the Sampling box

- Using the Reset Chn button in the Animation controls

More Keying Techniques

In this section, learn how to adjust the key using various methods to manipulate the key elements (tolerance, softness, and patches) in the RGB viewer, as well as the Softness Scaling controls in the Key menu.

It is recommended to read [Creating a Precise Key](#) on page 1665 and [Mastering the RGB Viewer](#) on page 1681 before proceeding.

Techniques for Adjusting Softness

This section includes three additional methods for adjusting the softness of the key.

Scaling the Softness Ellipsoid to Remove Grey Areas

Increasing the softness may create unwanted grey areas in the foreground subject. There are several ways to remove these grey areas. One method is to plot a pixel in a grey area, then translate, scale, or rotate the softness ellipsoid such that the plotted region is no longer in the ellipsoid. In effect, you will no longer be softening the plotted region.

If you translate, rotate, or proportionally scale the softness ellipsoid, all areas of the ellipsoid are affected to a degree. By contrast, when you use vertex scaling, you can affect a more localized area of the ellipsoid, leaving the rest of the ellipsoid unchanged. Vertex scaling is therefore often the most accurate method to use.

To scale the softness ellipsoid:

- 1 Show the canvas (press **C**) and hide the histogram (press **H**).
- 2 Use the Soft Display box to change the display of the softness ellipsoid to Cloud.
- 3 Select the softness ellipsoid in the RGB viewer by clicking on it or selecting Softness from the Picking box.
- 4 Display the CurResult clip to see the matte.
- 5 Zoom in to see the grey pixels up close.

- 6 Click Pref.
- 7 In the Preferences menu, click Plot.

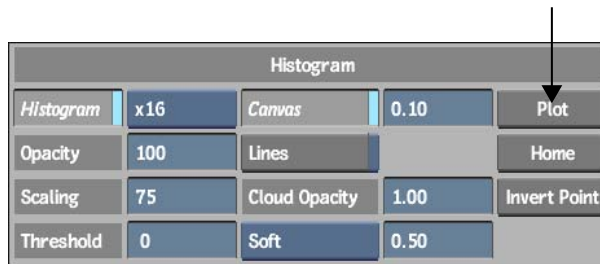

- 8 Plot a grey pixel in the foreground subject by clicking it.
The colour value of the pixel you clicked is plotted in the RGB viewer. The softness ellipsoid arrow passes through the plotted point.
- 9 To view the exact location of the plotted colour value in relation to the softness ellipsoid, rotate and scale the viewer.
The plotted point inside the softened region is represented by the softness ellipsoid.
- 10 Press **V**, click in the viewer and drag the cursor to the left to scale the ellipsoid down along the axis of the arrow. Watch the image update interactively. As soon as the grey area in the subject disappears, release the cursor to stop scaling the ellipsoid.

NOTE If you are not satisfied with the result, click Undo to return the ellipsoid to its previous shape, then scale again.

- 11 If some grey areas remain, plot those areas and repeat the procedure.

Scaling the Softness Ellipsoid to Add to Softness

You can also use the technique described in the previous section to increase the softness at the edges of the key. Start by identifying the region where you want to introduce more softness, and then plot a pixel in that area. You see the colour value in the viewer. Press the **V** hot key, then either enlarge or decrease the size of the softness ellipsoid minimally by dragging the cursor to the right or left. Include the colours you want and exclude the rest.

TIP Display the 3D histogram to help you figure out the direction in which you want to scale the tolerance or softness.

Using the Softness X,Y, and Z Fields

You can also adjust the softness in the key by changing the values in the Softness Scaling X, Y and Z fields. Drag the cursor over the fields, watching the result in the image window. You can often get a good result just by experimenting.

Softness - Noise	
Colour	RGB
Prop	1.00
Scale X	1.00
Scale Y	1.00
Scale Z	1.00

NOTE The Sampling box does not have to be set to Softness to use these fields.

Adjusting Transparencies with Patches

When keying transparencies, the transparency is sometimes either not visible enough or too prominent in the final composite. You can use patches to lighten or darken transparencies.

To adjust a transparency using a patch:

- 1 Use the basic keying technique to get the transparency as soft as possible.
- 2 Sample a patch in the transparency. See [Adding a Patch](#) on page 1678.
- 3 View the final composite by displaying the CurResult view.
- 4 Do one of the following:
 - To lighten the transparency, set the Colour of the patch to 0 and the Opacity to 100, then lower the Opacity.
 - To darken the transparency, set the Colour of the patch to 100 and the Opacity to 0, then raise the Opacity.

Setting 3D Keyer Preferences

The following section explains the available preferences for working in the 3D Keyer.

Auto Key

Enable this button to set keyframes to animate the key. See [Animating Key Elements](#) on page 1700 for details.

Regen

When you sample (softness, tolerance, and so on) using the colour picker or the numeric fields, you have the option of having the image update interactively as you move the cursor, or having the image update only when you release the cursor.

It is useful to update the image only after sampling if interaction during sampling is slow. This can happen if you are working with high resolution images, or if you are sampling while viewing a context from further along the pipeline. This can also occur in CurResult view, where a large amount of processing is required to display the result.

To update the image interactively:

- 1 Enable Regen.

To update the image after completing the sample:

- 1 Disable Regen.

Topics in this chapter:

- [About Garbage Masks](#) on page 1708
- [Accessing the Garbage Mask Menu](#) on page 1710
- [About Garbage Mask Options](#) on page 1712
- [Setting Mask Options](#) on page 1714
- [About Drawing Options](#) on page 1715
- [Setting Drawing Options](#) on page 1716
- [Drawing a Mask](#) on page 1717
- [Adjusting the Number of Points in Freehand Segments](#) on page 1722
- [Viewing Nodes in the Schematic](#) on page 1722
- [Changing the Priority Order of Masks](#) on page 1723
- [Transforming the Mask](#) on page 1724
- [Manipulating Vertices and Tangents](#) on page 1725
- [Animating Garbage Masks](#) on page 1728
- [Applying Motion Blur to Garbage Masks](#) on page 1738
- [Blurring a Stationary Garbage Mask](#) on page 1740
- [Rendering Garbage Masks in Interlaced Mode](#) on page 1740
- [Using Multiple Garbage Masks](#) on page 1741
- [Refining the Mask](#) on page 1743
- [Saving Garbage Mask Setups](#) on page 1757
- [Loading Garbage Mask Setups](#) on page 1758
- [Preset Garbage Mask Setups](#) on page 1759
- [Importing and Exporting Raw Setup Files](#) on page 1760

About Garbage Masks

When pulling a key, use garbage masks to isolate particular areas of an image to include with, or exclude from, the opaque area of the matte. Garbage masks are spline-based objects you draw directly on a clip or image. Depending on what you want to accomplish, you can set the area inside each garbage mask to be either opaque (white), transparent (black), or semi-transparent (any shade of grey).

Garbage masks are useful in many situations, such as when removing unwanted elements like equipment or people from a blue-screen shot, when removing unwanted borders from an image, or when creating complex keys by blending portions of the front and back clips. You can animate the shape of a garbage mask, apply motion blur to it, and even use the Stabilizer to make a garbage mask follow a moving element in a clip.

The following example illustrates keying out an unwanted white border using a garbage mask.

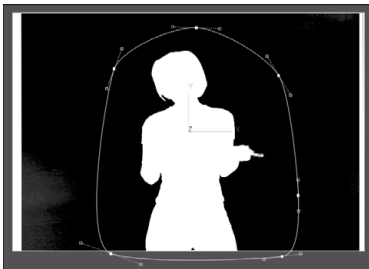

Matte before garbage mask is applied

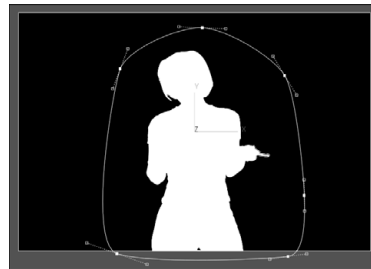

Matte after garbage mask is applied

You can use a parameter called Region of Interest (ROI) when drawing multiple garbage masks on a clip to remove the portion of the matte that falls outside each mask while respecting the area defined by all masks. ROI is only available when accessing the Garbage Mask menu from the Modular Keyer or the GMask node in Batch.

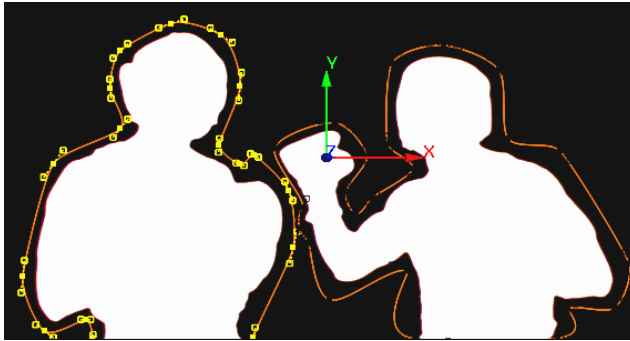

ROI enables you to reveal multiple parts of the matte.

Image courtesy of The Post Group

You can also apply softness to the edge of a mask using an advanced gradient. Instead of having an abrupt transition from white to black in the matte, you can control the gradations of grey between the key and the background. For example, softness can compensate for uneven edges of a key by blending the front and back clip. You can apply uniform softness around the edge of a mask or vary the softness range for different parts of the mask.

An advanced gradient adds two splines around the garbage mask. By moving points on these splines, you can control the gradient according to how far the surrounding spline is offset from the garbage mask.

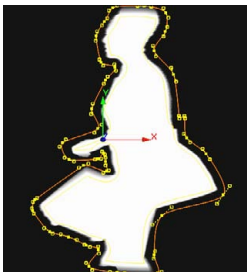

Softness applied around edge of garbage mask spline

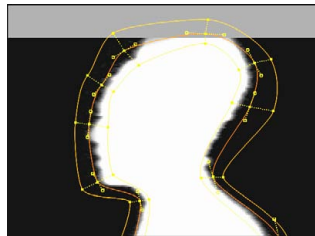

Advanced gradient varies softness for different parts of the garbage mask

Images courtesy of Behavior Communications Inc.

You also have the option of using the Tracer with an advanced gradient. The Tracer is an additional softness tool you can use to pull a key from scratch, allowing you to key images with a lot of detail at the edges. It uses a system

of localized keys, called *pickers*, which analyse the colour information both inside and outside the mask to derive a key for the mask edge. Within the same garbage mask, you can have portions of it using the Tracer, while other portions use an advanced gradient.

The Tracer is particularly useful for keying challenges such as:

- Very fine, wispy talent edges (hair, fur, or lace) where a blue or green screen may show through.
- An object not shot on a blue or green screen.

The Tracer is only available when you access the Garbage Mask menu from the Modular Keyer or the GMask node in Batch.

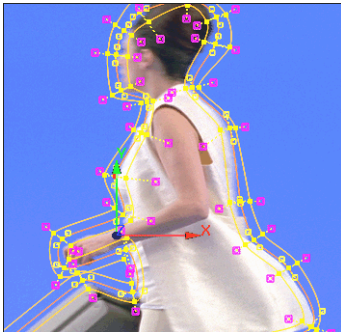

Garbage mask with pickers sampling image for more advanced softness

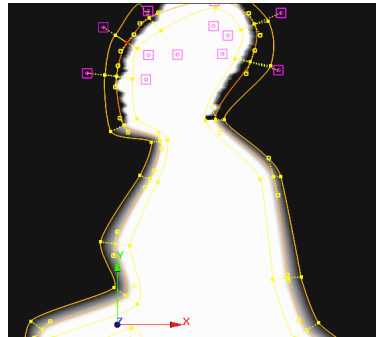

Garbage mask with pickers applied to only select vertices, the remainder using an advanced gradient

Images courtesy of Behavior Communications Inc.

Accessing the Garbage Mask Menu

Access the Garbage Mask menu from the Keyer when you have keyed a clip, and you want to define additional areas to include with, or remove from, the key using garbage masks.

Access the Garbage Mask menu from the Modular Keyer or the GMask node in Batch when you want to use multiple garbage masks or use the Tracer for detailed masks.

To access the Garbage Mask menu from the Keyer:

- 1 In the Keyer, click GMask.



The Garbage Mask menu appears.

To access the Garbage Mask menu from the Modular Keyer or from Batch:

- 1 Add a Gmask node to the processing pipeline in the Modular Keyer or the processing tree in Batch.

NOTE In the Modular Keyer, the default processing pipeline contains a Gmask node in the Matte branch.

- 2 Click the Gmask node.

The Garbage Mask menu appears.

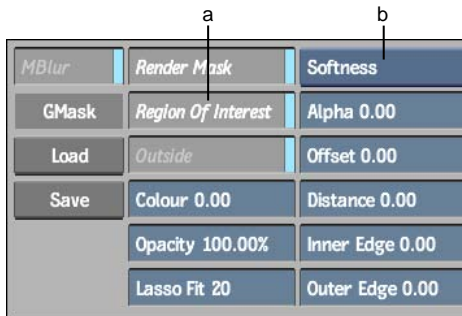

(a) Region of Interest button (b) Softness/Tracer box

About Garbage Mask Options

You can customize a mask's properties in the Garbage Mask menu.

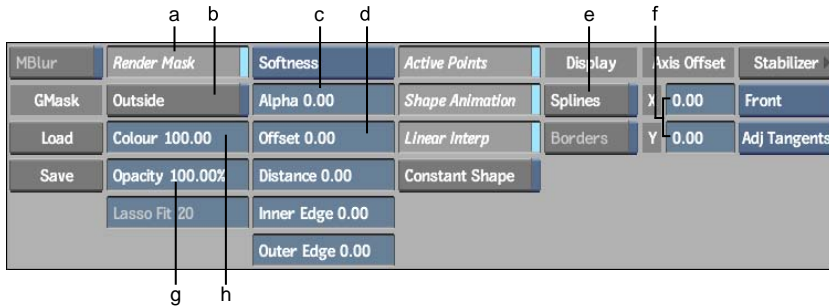

(a) Render Mask button (b) Outside button (c) Alpha field (d) Offset field (e) Splines button (f) Axis Offset fields (g) Opacity field (h) Colour field

Render Mask Turns masks on or off as you work. A mask that is turned off can be seen in the image window, but it has no effect on the image. Masks are turned on by default.

NOTE This parameter cannot be animated.

Outside Applies the effect to the part of the image that is outside the mask.

Colour Sets the blend value between the front and back image in the area that the mask is affecting (that is, either outside or inside the mask). A value of 50% is a 50/50 blend between the front and back clip. A value of 100% is the front clip. A value of 0% is the back clip.

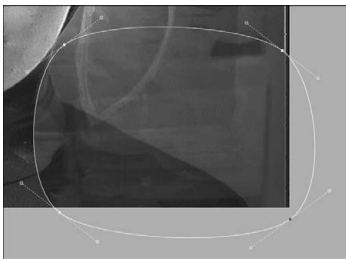

Mask with 25% colour

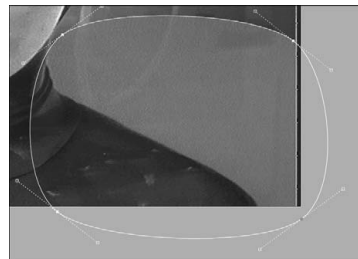

Mask with 75% colour

Opacity Sets the opacity of the matte in the area affected by the mask (that is, either inside or outside the mask). A value of 100% means the matte is

completely opaque; 50% means the matte is 50% transparent; and 0% has no effect on the image.

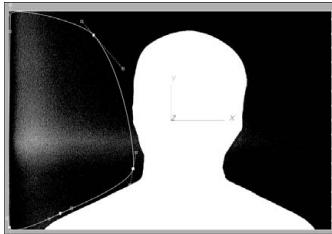

Mask with 0% opacity

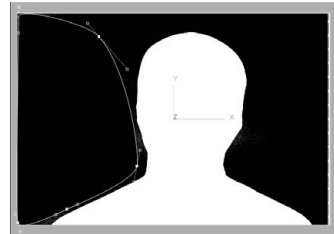

Mask with 100% opacity

Lasso Fit Increase or decrease the number of points in the segments of the mask that are drawn freehand. See [Adjusting the Number of Points in Freehand Segments](#) on page 1722.

Tracer/Advanced Gradient Use an advanced gradient to set different levels of softness for different parts of the mask edge. In the Modular Keyer or the GMask node in Batch, use the Tracer to set variable softness around the mask edge using pickers. See [Refining the Mask](#) on page 1743.

Alpha Defines the transparency of the gradient from the edge of the mask.

Offset Defines the border position of the gradient from the edge of the mask.

Inner Edge, Outer Edge, Distance Applies the distance and degree of change between the opaque and transparent part of the mask edge.

Linear Interp Enable to use linear interpolation of the mask border between keyframes. Disable to use rounded (hermite) interpolation.

Constant Shape Enable to modify the mask's shape without setting keyframes. This forces all animatable parameters (except the Tracer parameter Sample On) to be set for the whole clip rather than for only the current frame. It also removes any existing keyframes and applies the shape of the current frame to the rest of the clip.

Splines Enable the display of softness, borders and pickers.

Borders Enable the display of borders. The Border button is active when the Advanced Gradient and Tracer menus are displayed.

Pickers Enable the display of pickers. The Pickers button is only displayed in the Tracer menu.

X/Y Defines the mask's X and Y offset from its axis.

Setting Mask Options

Using the Garbage Mask menu, you can control how a mask affects the matte. For example:

- Set the opacity, colour, and edge softness of the mask.
- Specify whether the effect is applied to the inside or outside of the mask.
- Adjust the offset of the mask from its axis.
- Turn a mask on or off.

To set mask options:

- 1 Display the Matte or Result view.



- 2 Select the mask in the image window:
 - Click anywhere on the garbage mask spline.
 - Click the Geom node in the schematic.
- 3 Access the Garbage Mask menu.
The Garbage Mask menu appears.

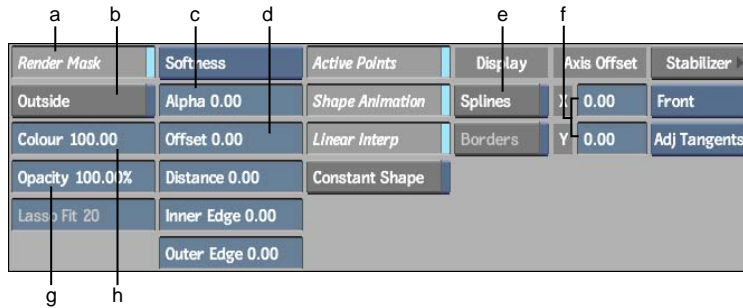

(a) Render Mask button (b) Outside button (c) Alpha field (d) Offset field (e) Splines button (f) Axis Offset fields (g) Opacity field (h) Colour field

- 4 Set the mask options. See [About Garbage Mask Options](#) on page 1712.

About Drawing Options

Use the Mask Setup menu to access mask drawing options. In Batch, these options are available in the Modular Keyer and Gmask Node Setup menu.

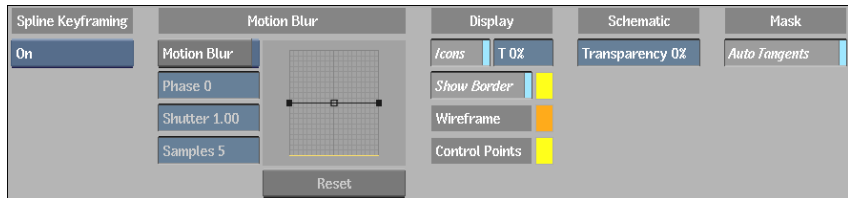

Spline Keyframing box Determines under what conditions keys are set, and for which parameters, when you are animating a garbage mask spline. See [Animating Masks Using Spline Keyframing](#) on page 1730.

Motion Blur settings Controls motion blur applied to garbage masks that can be used to match the movement of objects in a clip. See [Applying Motion Blur to Garbage Masks](#) on page 1738.

NOTE There are additional setup options to do with animating garbage masks. These only appear when you disable Shape Animation in the Garbage Mask menu. For more information, see [Animating Masks Using Spline Keyframing](#) on page 1730.

Icons button Globally displays or hides the garbage mask splines and axes.

NOTE If you hide garbage masks splines and axes with the Icons button, the Widget All / Widget Sel button in the View menu has no effect.

Transparency field Sets the transparency for the garbage mask splines and axes.

Show Border button Displays the Softness Offset wireframe border, defined in the Shape menu.

Show Border colour pot Sets the colour for the Softness Offset wireframe.

Wireframe colour pot Sets the colour for the wireframe of the garbage mask.

Control Points colour pot Sets the colour of the garbage mask vertices.

Pickers Display colour pot Sets the colour of the Tracer's pickers. This element is only available when accessing the Garbage Mask Setup menu from the GMask node in Batch or the Modular Keyer.

Schematic Display Transparency field Sets the transparency of the nodes in the garbage mask schematic.

Rendering box Select the rendering method.

Auto Tangents button Positions a tangent for each vertex set to create a smooth curve between the vertices. When Auto Tangents is disabled, the tangents are positioned under the vertex, resulting in straight lines between vertices. When you draw freehand segments in a mask with Auto Tangents off, vertices are added with broken tangents, allowing the mask to follow your cursor movement.

Setting Drawing Options

Before you create a mask, set the options according to how you want to draw and display the mask.

To set the drawing options:

- 1 Do one of the following:
 - In the Garbage Mask menu accessed from the Keyer, click Mask Setup. The Garbage Mask Setup menu appears.

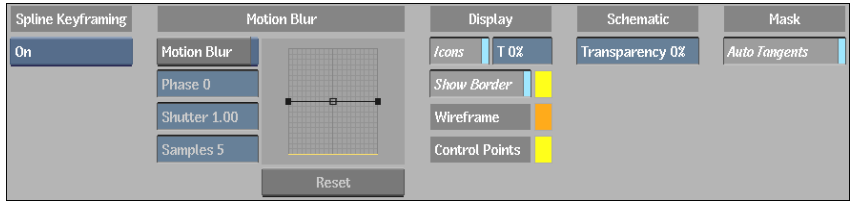

- In the Garbage Mask menu accessed from the GMask node in Batch or the Modular Keyer, click Node Setup. The Garbage Mask Setup menu appears.

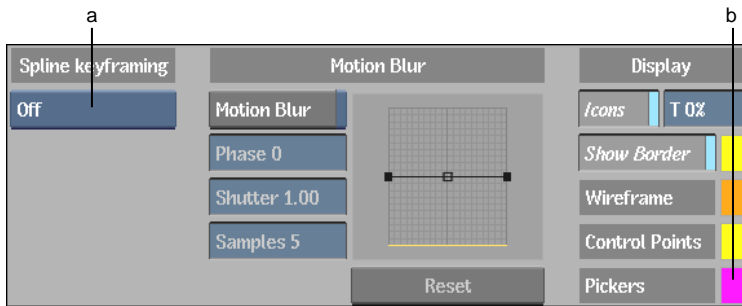

(a) Spline Keyframing box (b) Pickers Display colour pot

- 2 Set drawing options. See [About Drawing Options](#) on page 1715.

Drawing a Mask

After setting the drawing options, you can draw the mask.

To draw a garbage mask:

- 1 In the Keyer menu, click GMask. The Garbage Mask menu appears.
- 2 Select the view where you want to draw the mask from the View box.

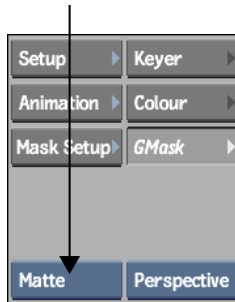

Which view you use depends on the context of your key and why you are drawing the mask. For example, if you want to crop the edges of a clip by drawing an opaque mask around the subject and then turning on Outside, try drawing the mask using the Matte view. Or, if you are rotoscoping a subject that has not been shot on a blue or green screen, try either the Front or Result view.

TIP In Batch or the Modular Keyer, you can use multiple viewports as you draw the garbage mask. For example, you can draw the mask in Matte view, while also displaying Result view. Using multiple viewports, you can immediately see how your mask affects the clip. For more information, see [Displaying Multiple Views](#) on page 136.

- 3 Do one of the following:
 - Click Add.
 - Select Create from the Edit Mode box.
 - Press N.
- 4 Do any of the following to draw the garbage mask:
 - Click to add vertices.

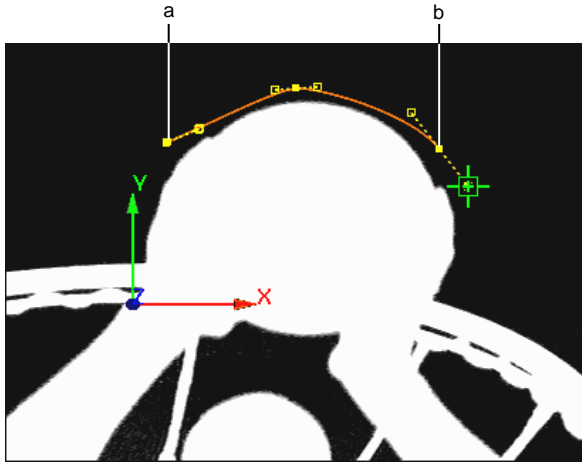

(a) Vertex added by first click (b) Vertex added by third click

- Press **Shift** to temporarily hide the vertices and tangents as you are drawing the mask.

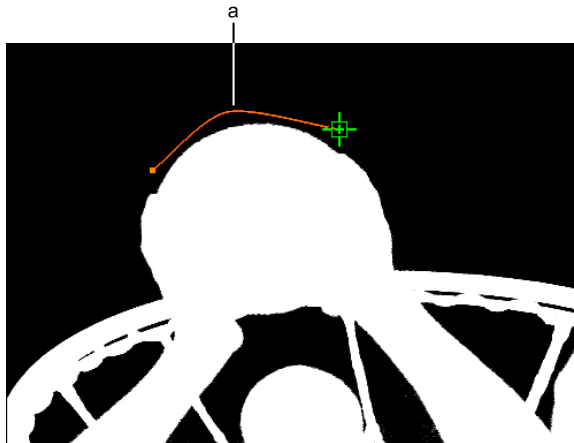

(a) Vertices are temporarily hidden while holding Shift

- Click-drag to control the tangency of any vertex as you are drawing the mask. When you release, you can continue to add vertices.

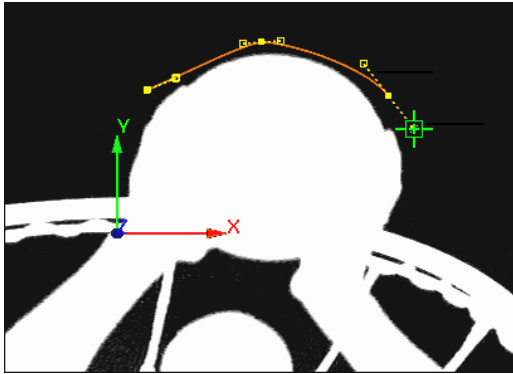

Tangency handles extend as you drag from a vertex

- **Shift**-drag to add freehand segments to the mask. The vertices and tangents of the mask you are drawing are temporarily hidden. Vertices are added where you drag, and appear when you release **Shift**. After closing the mask, you can use the Lasso Fit parameter to increase or decrease the number of vertices that define the freehand segments of the mask. See [Adjusting the Number of Points in Freehand Segments](#) on page 1722.

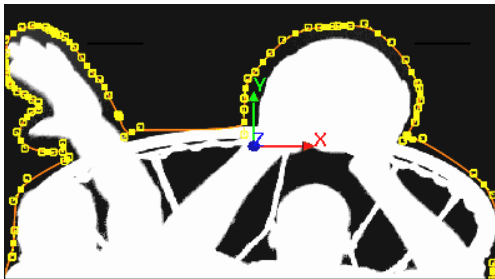

Segments of garbage mask drawn freehand

NOTE If you are drawing the mask with Auto Tangents turned off, freehand segments are drawn with broken tangents. See [Breaking Tangents](#) on page 1726.

- 5 To close the mask, do one of the following:
 - Click Close.

- Click the first vertex.
- Drag to the first vertex.

TIP You can also close the mask by pressing the hot key for the edit mode you want to use next: **M** for Move, **S** for Select, or **B** for Break. The mask closes and you are ready to work in that mode.

When the garbage mask is closed, its vertices and tangents can be edited and animated.



(a) Vertex (b) Tangent

If you want to view the nodes that are added with each new garbage mask, select Schematic from the View box or press the ~ key. You can use the Schematic view to access a menu, create parent-child relationships between masks and axes, delete masks, as well as perform other organizational tasks.

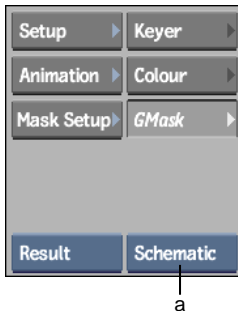

(a) View box

Adjusting the Number of Points in Freehand Segments

You can increase or decrease the number of points in freehand segments of a mask by adjusting the Lasso Fit value. An entire garbage mask can consist of freehand segments, in which case the Lasso Fit value affects the whole garbage mask. Otherwise, the Lasso Fit value only affects the part of the mask drawn freehand.

The Lasso Fit parameter loses its influence over freehand segments of a mask if you have edited points as follows:

- Added or deleted points using the Add or Delete Edit modes
- Saved and loaded a garbage mask
- Started a new session with the application

To adjust the number of vertices using Lasso Fit:

- 1 If necessary, select the garbage mask you want to affect.
- 2 Drag the Lasso Fit field. Increase the value to decrease the number of points in the freehand segments of the mask. Decrease the value to increase the number of points in the freehand segments.

Segments of the mask that have been drawn freehand are affected, while segments created by simple clicks remain unaffected.

NOTE If you move vertices of a garbage mask and then change the Lasso Fit value, all the vertices snap back to the original position where they were first drawn, and all animation is lost. This occurs only if the Lasso Fit value retains its influence on the garbage mask.

Viewing Nodes in the Schematic

When you create a garbage mask, an Axis node and a Geom node are added to the schematic. If you want to view the nodes, select Schematic view or press ~ (**Tilde**) to toggle to Schematic view.

The Camera node is always part of the scene. The Axis node contains rotation, scaling, position, and centre data. The Geom node contains information about how the mask will affect the image (softness, opacity, alpha, axis offset). The Camera node can parent the Axis node for greater precision over the garbage

mask, particularly if you want to rotate or orbit the camera with respect to the garbage mask.

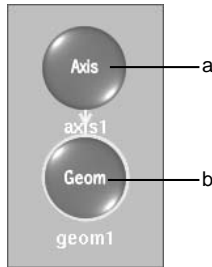

(a) Axis node (b) Geom node

You can double-click an Axis or a Geom node to view its related menu. You can delete a garbage mask by deleting its Geom node from the schematic.

For more information on working in Schematic view, see [Using the Schematic and Menu Tabs](#) on page 2100.

Changing the Priority Order of Masks

When you create several garbage masks on an image, you can change the order in which they are drawn, or layered in the scene. This affects the resulting image because a mask with a higher priority has precedence over one with a lower priority. You can use the priority order to create complex effects involving multiple garbage masks.

To set the priority of a mask:

- 1 Select the mask.
- 2 Click Push to move the mask down a layer; click Pop to move the mask up a layer.



NOTE You cannot animate the priority by setting Push and Pop at different frames. When you set a mask's priority with Push or Pop, it is set for the entire clip.

Transforming the Mask

You can apply transformations such as translation, rotation, scaling, shearing, and centre changes to a garbage mask. The transformation data for the mask is stored in its Axis node. You apply transformations to the mask using the Axis controls.

All transformation parameters in the Axis menu can be animated. You can use a motion path to animate the position of a mask. See [Creating a Motion Path](#) on page 2023.

You can also apply motion blur to a garbage mask. See [Applying Motion Blur to Garbage Masks](#) on page 1738.

To transform a mask:

- 1 Access the Garbage Mask menu.

The Axis controls appear.

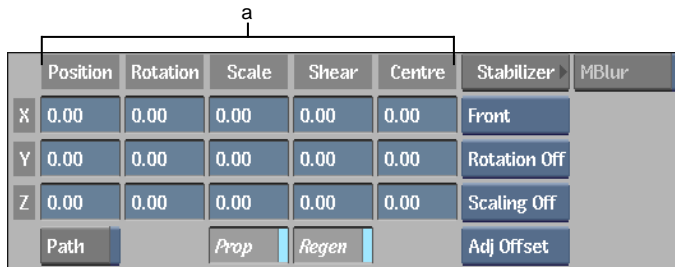

(a) Transformation fields

NOTE The Axis controls are similar to the Axis menu in Action.

- 2 Use the Transformation fields to modify the position, shape, and size of the mask.

Manipulating Vertices and Tangents

Use the options in the Edit Mode box to manipulate the vertices on the mask. You can edit the mask most easily in Front, Key-In, or Matte view.

Selecting Vertices and Tangents

You can select vertices and tangent handles when Select, Move, or Scale is selected in the Edit Mode box:

- To select an individual vertex or tangent handle, click the vertex or tangent handle.
- To select multiple vertices, **Ctrl**-drag a selection box over a series of vertices.
- To select multiple vertices using the pen, press the pen button and drag a selection box over a series of vertices.
- To add another vertex to a multiple selection, **Shift**-click the vertex.
- To add several more vertices, press **Shift+Ctrl** and drag a selection box over the additional vertices.
- To deselect all vertices, click anywhere outside the mask.

Selecting Pickers and Softness Vertices

You can select pickers or softness vertices using the following techniques.

To select a single picker or softness vertex:

- 1 Click the picker or vertex that you want to select.

To select multiple pickers or softness vertices:

- 1 Select the mask vertices that the pickers or softness vertices are associated with (see previous section).
- 2 Click a picker or softness vertex corresponding to one of the selected mask vertices.
The pickers or softness vertices are selected for all the selected mask vertices.

Moving Vertices and Tangents

You can move vertices and tangents using the Move and Scale options of the Edit Mode box:

- To move a vertex or tangent in any direction, select Move. Click the vertex or tangent and drag.

TIP If you have trouble selecting a tangent handle that is very close to the vertex, hold **Q** then select it.

- To move selected vertices in any direction, select Move. Click one of the selected vertices and drag.
- To move one or more selected vertices in the direction perpendicular to their tangents, select Scale. Click one of the selected vertices and drag.
- To ensure better continuity on a garbage mask, automatically adjust tangents as you move vertices or scale the mask. Press and hold **G** and then drag a vertex. See [Automatically Adjusting Tangent Handles of Adjacent Vertices](#) on page 1727.

Breaking Tangents

You can separate two tangent handles (“break” the tangent) and move them separately using the Break option from the Edit Mode box:

- To break and move a tangent handle, select Break and click the tangent handle. The tangent is displayed as a solid line, indicating it is “broken.”
- To reconnect two broken tangent handles, select Auto and click either of the two tangent handles. The tangent is displayed as a dotted line.
- To change the position of an individual tangent handle after releasing the cursor, select Move.

Removing and Adding Tangents

You can also use the Break option to remove tangents from vertices by clicking the vertex while in Break mode. When you remove a tangent, the curve defined by the tangent is removed.

The shape of the border line differs depending on whether adjacent vertices are broken:

- If adjacent vertices are unbroken, the border line curves as it approaches the vertices.
- If adjacent vertices are broken, the border line is straight as it approaches the vertices.

You can create a garbage mask composed entirely of straight edges by removing the tangents from all the vertices:

- To remove the tangent of a vertex, select Break and click the vertex.
- To add a tangent back to a vertex, select Auto and click the vertex. Alternatively, using the Break option, click the vertex and “drag” the tangent out again.

Automatically Adjusting Tangent Handles of Adjacent Vertices

When you move vertices, the tangent handles of the two adjacent vertices remain fixed in their current position. You can make them automatically adjust to create smooth curves between the vertices by pressing the **G** hot key as you move vertices.

You can reverse the behaviour so that dragging vertices automatically adjusts tangents without using the hot key. You reverse the behaviour by setting the following environment variable:

```
DL_GMASK_AUTO_MOVE_MODE
```

To reverse functionality of the G hot key:

- 1 From the home directory of the application, open the `.cshrc` file in a text editor:
- 2 Add the following line to the end of the `.cshrc` file:

```
setenv DL_GMASK_AUTO_MOVE_MODE
```
- 3 Save and close the `.cshrc` file.
- 4 In the home directory, type:

```
source .cshrc
```

- 5 Launch or restart the application.

When you click or move a vertex on a garbage mask, the tangents are automatically repositioned. When you press **G** and click or move a vertex, the tangents are not repositioned.

TIP Alternatively, you can set the environment variable in the shell pointing to the home directory of the application. When you set an environment variable in the shell, the environment variable is enabled for the current session only.

Creating Right-Angled Vertices

You can create right-angled vertices using the following technique.

Press:	To:
Ctrl+A	Select all vertices.
B	Break apart tangents.
G	Create right-angled vertices of selected vertices.

Animating Garbage Masks

You can animate a garbage mask using the Shape channel in the Channel Editor or using spline keyframing, which animates individual Vertex channels. Vertex channels correspond to the vertices—or handles—that appear along the perimeter of the garbage mask. The Vertex channel names are contained in the Spline folder in the Channel Editor.

You can apply tracking data to a mask's axis to animate a garbage mask. Existing keyframes are disregarded, after applying tracking data, you can animate individual vertices and make adjustments.

Animating Masks Using the Shape Channel

The Shape channel shows when the shape of the garbage mask changes during the animation.

To animate a garbage mask using the Shape channel:

- 1 In the Garbage Mask menu, click Mask Setup.
- 2 In the Garbage Mask Setup menu, turn on Spline Keyframing. Each time you move a vertex, a shape key is added at the current frame.

NOTE Disable Spline Keyframing if you do not want a keyframe added to the Shape channel.

- 3 Click Mask Setup again. The Garbage Mask menu appears.

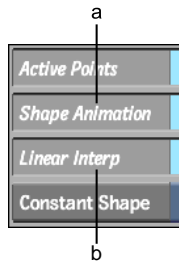

(a) Shape Animation button (b) Linear Interpolation button

- 4 Enable Shape Animation. If keyframes are already set for specific vertex channels, the following message appears: “Convert explicit channels to a single shape channel?”
- 5 Click Confirm. The Shape channel appears in the Channel Editor and any Vertex channel keyframes are converted.

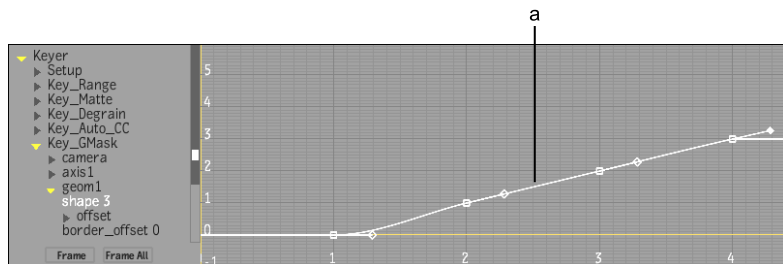

(a) Shape channel with 4 keyframes

NOTE Enabling Shape Animation disables the Vertex Keyframing and Channel Selecting boxes in the Garbage Mask Setup menu. These contain options for animating individual vertex channels. See [Animating Masks Using Spline Keyframing](#) on page 1730.

- 6 Depending on how you want to animate the garbage mask, use the Linear Interpolation and Constant Shape buttons as follows.

Enable:	To:
Linear Interpolation	Make the garbage mask trajectory linear. Enable this button when rotoscoping. For smooth garbage mask animation, disable this button.
Constant Shape	Keep the garbage mask shape the same for all frames. When you enable this button, the following message appears: "Remove all keyframes except current one?" Click Confirm.

Animating Masks Using Spline Keyframing

You can animate the shape of a mask by moving the vertices of a garbage mask spline at different frames throughout the clip. Each vertex has its own X, Y and Z position channels in the Channel Editor, as well as several other parameters, as shown in the following table.

Parameter	Channel Editor Folder & Name(s)	Channel Editor Values
The position of the mask vertices.	<i>position: X, Y, Z</i>	
The position of the left and right tangent handles relative to the mask vertex.	<i>tangents: left, right</i>	
The tangent continuity (handles broken or unbroken).	<i>tangents: continuity</i>	0 = broken handles 1 = unbroken handles
The active/inactive status of mask vertices. See Adding and Removing Vertices on page 1733.	<i>Vertex_x: active</i>	0= inactive 1 = active

Before you start to animate the mask, set the Spline Keyframing options in the Garbage Mask Setup menu. In the Modular Keyer or Gmask node in Batch,

these options are located in the Node Setup menu. Use these options to specify which elements will get a keyframe as you animate the mask.

As you adjust the mask, you can opt to apply keyframes to selected vertices or to all vertices. To quickly animate a mask, keyframe all vertices every time you adjust a single vertex. This way, what you see at a given frame will be exactly what you get no matter how you animate the “surrounding” frames.

To have more control over the shape of the mask frame by frame, animate one vertex at a time. This method is useful for tracking garbage masks and keeping control over tangent animation. See [Animating Masks Using Tracking](#) on page 1735.

By combining the Spline and Vertex Keyframing options in different ways, you can set an animation mode to suit the task at hand. For example, by selecting Item and All Vertices, you could animate just the tangent handles of all vertices on the mask.

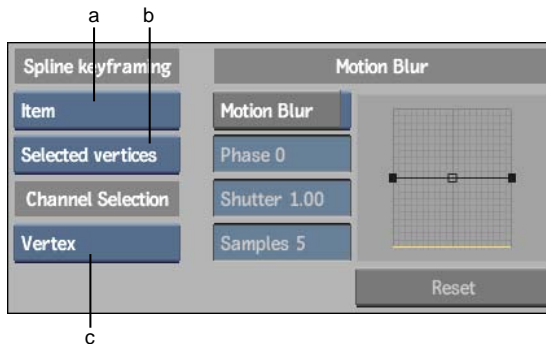

(a) Spline Keyframing box (b) Vertex Keyframing box (c) Channel Selecting box

Spline Keyframing box Sets the conditions under which keyframes are set, and for which parameters.

NOTE The Spline & Tracer, Spline only, and Item options are only available if you disable Shape Animation in the Garbage Mask menu.

Select:	To:
Spline & Tracer	Set a keyframe for all the parameters of the vertex or vertices and related elements, with the exception of the Sample On parameter. This option is only available where you can access the Tracer.

Select:	To:
Spline only	Set a keyframe for one or more vertices, or related elements, for the specified parameter, as well as for the mask vertex position and the tangent position channels.
Item	Set a keyframe for a parameter of a vertex, or of a related element. Only the particular parameter gets a keyframe.
On	Set a keyframe for the shape channel when a change to a vertex is made (such as moving a vertex or tangent handle, breaking tangent handles, or changing the Active/Inactive status of a vertex). This option is only available when Shape Animation is enabled in the Garbage Mask menu.
Off	No keyframes are set.

Vertex Keyframing box Sets the conditions under which parameters are applied to specified vertices in the mask.

NOTE The Vertex Keyframing box is only available if you disable Shape Animation from the Garbage Mask menu.

Select:	To:
All Vertices	Set a keyframe for the parameter you are animating for all the vertices of the mask. Related elements, such as tangents, also all get a keyframe when you animate a parameter on the mask.
Selected Vertices	Set a keyframe for the parameter you are animating for all selected vertices on the mask. Related elements, such as tangents, that are selected, also all get a keyframe when you animate one on the mask.

Channel Selecting box Determines which channels are selected in the Channel Editor when you select one or more vertices.

NOTE The Channel Selecting box is only available if you disable Shape Animation from the Garbage Mask menu.

Select:	To:
Vertex	Select all the channels related to the vertices you select on the garbage mask. For example, whether you select a vertex or one of its tangents, its active, position, and tangent channels are also selected in the Channel Editor.

Select:	To:
Item	Select only the particular channel corresponding to the selected vertices. For example, if you select the right tangent handle of a vertex, only the corresponding right channel is selected in the Channel Editor.

Adding and Removing Vertices

To further control the shape of a mask throughout the clip, you can add and remove vertices from your mask at any frame of the clip. For example, if the shape changes radically or gets bigger part way through the clip, you can add vertices to reshape the mask at that frame. When you add a vertex part way through the clip, it is added to the whole clip but respects the existing shape of the mask in all previous and subsequent frames. Therefore, any reshaping that you have done to the mask is not affected by the new vertices.

NOTE Adding or deleting vertices on masks with freehand segments causes the Lasso Fit value to lose influence. See [Adjusting the Number of Points in Freehand Segments](#) on page 1722.

If you delete a vertex, it becomes “inactive” from that frame to the next active/inactive keyframe set for that vertex, or, if there are no keyframes, to the end of the clip. An inactive vertex has no effect on the shape of the mask. On previous frames, the vertex is still active, so the mask shape is unchanged by the deletion. To delete the vertex completely (that is, throughout the whole clip), click it a second time.

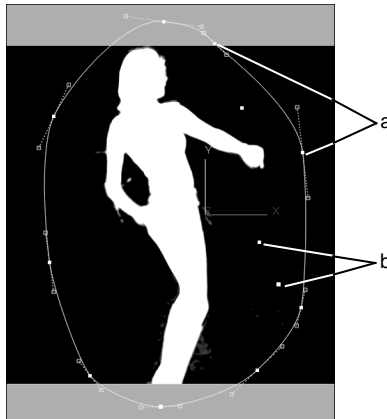

(a) Active vertices (b) Inactive vertices

Use the options in the Edit Mode box to add and delete vertices from the mask, and to control which vertices are active and inactive.

To add a vertex to the entire mask:

- 1 Select Add from the Edit Mode box.
- 2 On any frame in the clip, click the mask where you want to add the vertex.

The new vertex is added and is active throughout the clip. It does not affect the existing mask animation, regardless of where in the clip you add the vertex.

To make an active vertex inactive:

- 1 Switch to Delete mode.
- 2 Click the vertex.

The vertex is inactive from the current frame to the next frame where an Active/Inactive keyframe has been set, or, if there are no keyframes, to the end of the clip. The status of the vertex on previous frames is unchanged.

NOTE Alternatively, use the Active button in the Shape menu to make vertices inactive. Select the vertex you want to make inactive (you must be in Select, Move, or Scale mode), and then click Active.

To make an inactive vertex active:

- 1 Switch to Add mode.
- 2 Click the inactive vertex.

The vertex is active from the current frame to the next frame where an Active/Inactive keyframe has been set, or, if there are no keyframes, to the end of the clip. The status of the vertex on previous frames is unchanged.

NOTE Alternatively, use the Active button in the Shape menu to make vertices active. Select the vertex you want to make active (you must be in Select, Move, or Scale mode), and then click Active.

To delete a vertex from the mask:

- 1 At any frame, switch to Delete mode.
- 2 Click the vertex.
It becomes inactive.
- 3 Click the vertex a second time.
It is removed from the mask for the duration of the clip.

NOTE You cannot delete the last three vertices of a mask, as they are the minimum necessary to define it. If you want to delete the mask, you delete its Geom node in the Garbage Mask Schematic.

Animating Masks Using Tracking

You can animate a mask by applying tracking data to it. This is useful when you want a garbage mask to follow a moving element in a clip. To do this, you can either:

- Animate the entire mask by applying the data to the mask's axis.
You can track an object on the front or back clip and apply the tracking data to the axis of a mask, or to a hierarchy of masks.
- Animate selected vertices according to reference points that you set in the Stabilizer.
Each vertex you select is assigned a tracker in the Stabilizer. The vertices are repositioned according to the reference points that you set in the Stabilizer.

When you apply tracking data to a mask, only the mask axis, or position of selected vertices, is animated. Any other keyframes set for the mask are disregarded. You can, however, animate individual vertices after applying tracking data to your mask's axis or to individual vertices. It is especially useful to manually adjust the tangent handles of the vertices at different frames where needed.

To animate an entire mask with tracking:

- 1 Access the Garbage Mask menu.
The Garbage Mask menu appears.

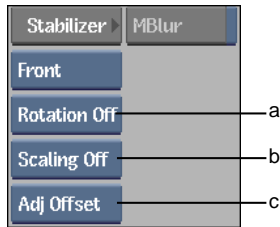

(a) Clip box (b) Rotation and Scaling options (c) Adjust box

- 2 Select the mask.
- 3 From the Clip box, select the clip you want to track.
- 4 If necessary, adjust the mask using the Position, Rotation, Scale, Shear, and Centre fields.
- 5 Set the Rotation and Scaling options. To track rotation, select Rotation On; to track scaling, select Scaling On.
- 6 Select an option from the Adjust box.

Select:	If the selected mask is:
Adj Offset	Parented to one axis.
Adj Axis	Parented to a hierarchy of objects.

- 7 Go to the frame where you want to start tracking.
- 8 Click S.
The Stabilizer appears.
- 9 Position of the trackers.

NOTE The first tracker is for position data and the second tracker is for rotation and scaling data. If rotation and scaling were not selected, the second tracker has no effect.

- 10 Click Analyse.
Fine-tune your analysis if necessary. For more information, see [About Tracking and Stabilizing](#) on page 1781.
- 11 Click Return.

The Garbage Mask menu reappears. The tracking data is applied to the mask.

- 12 Fine-tune your mask if necessary.

To animate individual vertices on a mask with tracking:

- 1 Select a vertex or a group of vertices on a mask.
- 2 Access the Garbage Mask menu.
The Garbage Mask menu appears.

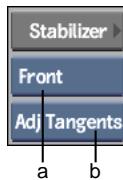

(a) Clip box (b) Adjust box

- 3 From the Clip box, select the clip you want to track.

NOTE When tracking vertices on a mask using the Garbage Mask menu in the Modular Keyer or the GMask node in Batch, you can only track the front clip.

- 4 From the Adjust box, select Adj Tangents.
The tangents for the selected vertices are adjusted while the points are being tracked.
- 5 Go to the frame where you want to start tracking.

- 6 Click S.
The Stabilizer appears. The trackers are automatically placed in the position of the selected vertices. Reposition if needed.

- 7 Click Analyse.
Fine-tune your analysis if necessary. For more information, see [Tracking and Stabilizing](#) on page 1781.

- 8 Click Return.
The Garbage Mask menu reappears. The tracking data is applied to the selected vertices on the mask.

- 9 Fine-tune your mask if necessary.

Applying Motion Blur to Garbage Masks

Use motion blur on a garbage mask to compensate for the movement of an object in a clip. Motion blur is created according to the animated movement of a mask's vertices. The amount of blurring is affected by the speed of the mask's movement.

Motion blur can account for the natural blurring of an object as it moves or rotates in space. For example, assume you are drawing a garbage mask around a car as it turns a corner. Because you are using an overhead shot, the edges of the car where motion blur occurs change as the car accelerates and rounds the corner. By applying motion blur to the mask, which has animated position and rotation values to match the car's movement, appropriate blurring of the car's edges into the background clip occurs.

TIP Besides the practical use of blurring a garbage mask, that is, to match the movement of an object you are keying, you can try blurring masks for artistic effects in multi-layered composites.

To apply motion blur to a garbage mask:

- 1 Access the Garbage Mask Setup menu.

The Motion Blur controls are available in the left-hand portion of the menu.

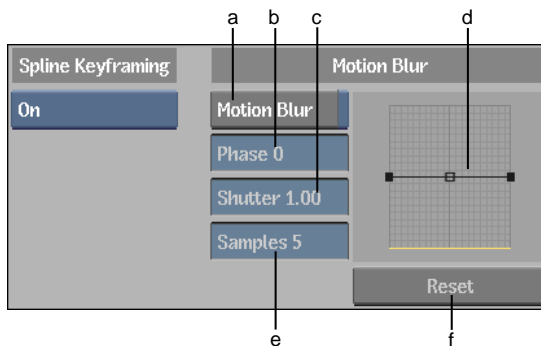

(a) Motion Blur button (b) Phase field (c) Shutter field (d) Motion Blur curve
(e) Samples field (f) Reset button

- 2 Set the motion blur as follows.

Samples field Determines the quality of the motion blur produced by the number of samples taken at each frame. Increasing the Samples value causes the processing time to increase linearly.

Motion Blur curve Determines the transparency of the samples that create the blurring effect. The left side of the curve controls the samples of the incoming movement of the subject in the frame. The right side of the curve controls the samples of the outgoing movement of the subject in the frame.

For example, to add blur to the left edge of the mask as it travels from left to right in the clip, adjust the motion blur curve so it slopes down. If you want to add a bit of blur on each side of the mask, adjust the motion blur curve so it peaks in the middle.

Select one of the three vertices on the curve to move it. When you select a vertex, its tangent handle is displayed. You use the tangent handle to adjust the slope of the curve.

Shutter field Controls the duration of the motion blur at each frame, which affects the size of the motion blur. Increasing Shutter value does not increase the processing time.

Phase field Specifies whether the motion blur is based on the movement before or after the current frame. A value of -100 places the motion blur before the frame, while a value of 100 places the motion blur after the frame. A value of 0 is centred, which evenly distributes the motion blur. The default value is 0.

NOTE The garbage mask motion blur settings are similar to those in the Axis menu in Action.

Motion blur occurs on the mask according to the settings you select and the speed its vertices traverse the clip.

- 3 Enable Motion Blur. This makes the motion blur available for application on any garbage mask or axis in the setup.

NOTE Motion blur settings are applied uniformly to all garbage masks in the setup.

- 4 To reset all motion blur settings back to their default settings, click Reset and then click Confirm.
- 5 To apply motion blur to a garbage mask, access the Garbage Mask Shape controls, select the garbage mask, and then enable MBlur.

The settings specified in the Garbage Mask Setup menu will be used to create the motion blur effect on the garbage mask. You can select one garbage mask at a time.

- 6 To apply motion blur to an axis, select the axis, and then enable MBlur. The settings specified in the Garbage Mask Setup menu will be used to create the motion blur effect on the axis. You can select one axis at a time.

Blurring a Stationary Garbage Mask

You can create a motion blur effect for a garbage mask without having the mask actually change position. This could be useful, for example, if you would like to simulate movement in a stationary image.

To apply axis motion blur:

- 1 Toggle to schematic view and add a new axis.
- 2 Parent the new axis to the garbage mask axis.

The garbage mask and the new axis should now both be parented to the garbage mask axis.

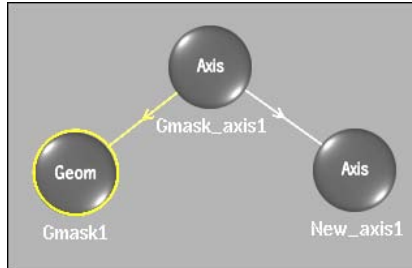

- 3 Apply motion blur to the new axis. Motion blur is applied to the stationary garbage mask.

Rendering Garbage Masks in Interlaced Mode

You can render garbage masks in Interlaced mode to accommodate video material.

To render garbage masks in Interlaced mode:

- 1 Do one of the following:
 - From the Modular Keyer or the GMask node's menu, select Interlaced from the Rendering box.

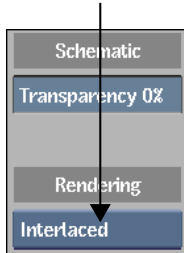

- From the Keyer's Setup menu, select Interlaced from the Rendering box. This setting affects both the Keyer and any garbage masks you create. For more information, see [Field and Frame Rendering](#) on page 1599.

Using Multiple Garbage Masks

Use the Region of Interest feature on clips containing multiple garbage masks that each hide a portion of the matte. Region of Interest ensures that multiple overlapping or non-overlapping garbage masks all respect the areas defined by one another. Furthermore, you can individually modify the opacity of each mask.

Region of Interest is only available when accessing the Garbage Mask menu from the Modular Keyer or the GMask node in Batch.

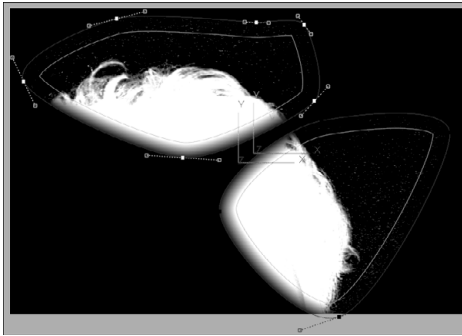

Two garbage masks with Region of Interest enabled

To draw more than one garbage mask revealing a matte:

- 1 In the Garbage Mask menu, select Geom from the Object box and click Add.

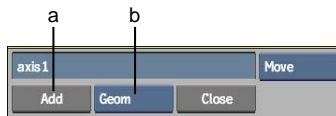

(a) Add button (b) Object box

- 2 Draw the first garbage mask.
 - 3 Switch to Result view.
 - 4 Enable Region of Interest.
Outside is enabled and the Colour is set to 0.0 for the mask.
-
- NOTE** Disabling Region of Interest toggles the Colour setting back to what it was before.
-
- 5 Adjust offsets and softness as required.
 - 6 To adjust the individual opacity for each mask, select the mask and then adjust the value in the Opacity field.
 - 7 Draw any other garbage masks as needed.

NOTE Each time you add a garbage mask with ROI enabled, Result view is temporarily cleared of all masks so that you see the entire matte. This way you have a better view of what you want to reveal and mask.

Refining the Mask

You can adjust the softness gradient of a mask to smoothen its edges. You can smoothen the gradient towards the inside edge, the outside edge, as well as the area where the inside and outside adjustments have an effect. You can create a uniform gradient around the edge of the mask, or use an advanced gradient to control the shape of the gradient at different parts of the mask.

To create a uniform gradient, you define how far you want the gradient to be offset from the edge of the mask and then set its transparency. To vary the shape of the gradient, you move vertices on inner and outer softness splines. The gradient will be based on how far each vertex point is offset from the mask.

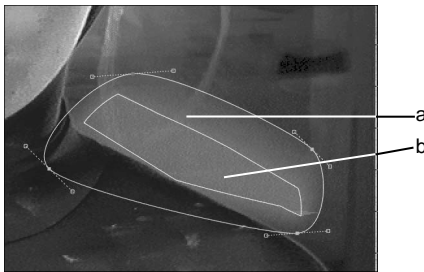

(a) Alpha region (b) Inner offset

When using the Tracer, you can work in two modes: advanced gradient and pickers. Individual vertices can be set to either of these modes. Advanced gradient is the default mode when working in the Tracer, and applies a gradient according to the distance of the softness borders from the garbage mask spline.

Advanced gradient provides a versatile method for setting the softness of the mask edge. It allows you to customize the softness gradient at different parts of the mask. The advanced gradient has two softness borders, one inside and one outside the mask border. It also includes inner and outer softness vertices for each regular mask vertex.

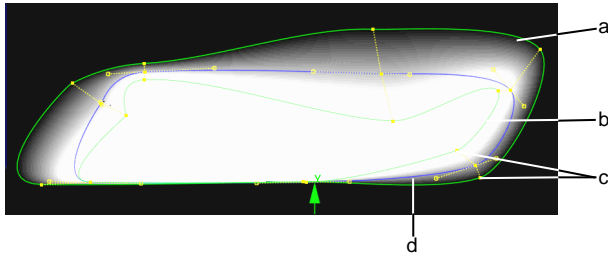

(a) Outer Softness border (b) Inner Softness border (c) Softness vertices (d) Mask border

Some potential uses for the advanced gradient are:

- Creating compositing effects when using Action
- Removing wires
- Pulling a key with pickers on areas of the mask where pickers are not needed

You can change the default mode of the Tracer from advanced gradient to pickers, a system of localized keys. Tracer analyses the colour information both inside and outside the mask, then compares the values and uses a keying algorithm (the same one used in the 3D Keyer) to derive a key for the mask edge. This system allows you to key images with a lot of detail at the edges.

NOTE For good results with the Tracer, the object must have sufficient (and relatively consistent) chroma and luma differences between its foreground and background.

To control softness and advanced gradients, use the Garbage Mask Shape controls.

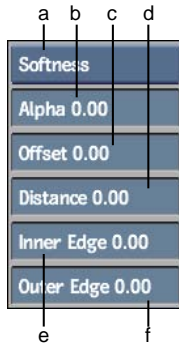

(a) Softness box (b) Alpha field (c) Offset field (d) Distance field (e) Inner Edge field (f) Outer Edge field

Applying Softness Using a Uniform Gradient

Use the Softness fields to apply a constant range of softness to the edge of the mask. The Alpha and Offset fields define the fade-out of the softness gradient from the edge of the mask.

Once gradient transparency and offset have been determined, the degree of smoothness can be set using the Inner Edge and Outer Edge fields. You can then use the Distance field to determine the area where Inner Edge and Outer Edge settings have an effect.

To apply uniform softness:

- 1 Access the Garbage Mask menu.
- 2 Select a mask in the image window.
- 3 If necessary, toggle the Advanced Gradient button to Softness.



- 4 Set the border of the softness gradient using the Offset field. The gradient will be affected by how far the softness border is offset from the edge of the mask.
- 5 Set the transparency of the gradient using the Alpha field.
- 6 Use the Inner Edge field to smoothen the softness gradient towards the inside.
- 7 Use the Outer Edge field to smoothen the softness gradient towards the outside. Adjusting this value is especially noticeable if you are smoothening a transition from a black inside edge to a white outside edge.
- 8 Use the Distance field to modify the area of which the Inner and Outer Edge adjustments have an effect.

Applying Softness Using Pickers

You can change the default mode of the Tracer from advanced gradient to pickers, allowing you to sample colours inside and outside the garbage mask spline, to apply softness according to the colour transition in the clip. Individual vertices can be set to either of these modes.

When great control over the mask edge is needed, for example, for fine edge detail, use pickers to effectively key out the background. The Tracer uses pairs of pickers to do luma and chroma analysis of the area inside and outside of the mask and derives localized edge keys from this information.



(a) Pickers—Colour analysis is done in the area inside the pickers.

The area that each picker affects extends halfway towards the two adjacent mask vertices, and up to the two softness borders, as shown in the following example.

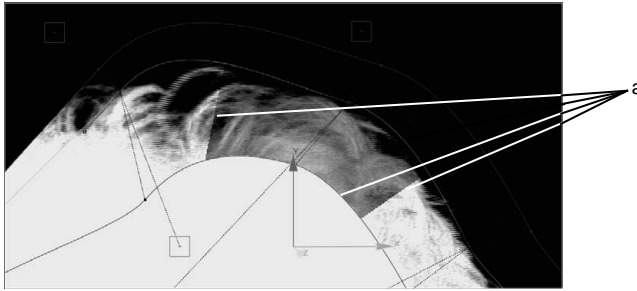

(a) Borders of area of pickers' influence.

Using pickers, you can key objects that otherwise would be extremely difficult to key. Imagine a golden horse with a very fine mane on an unfocused background of various colours. As long as you have some chroma/luma differences in the background (green vegetation, blue sky, black earth or rocks), you can 'force' the outside pickers to sample these colour values. The inside pickers can sample the golden average values, and the Tracer can generate a soft-edged matte based on the difference between the two sets of values.

Pickers can be selected and manipulated independently of the vertices they are associated with. See [Selecting Pickers and Softness Vertices](#) on page 1725.

Mixing Advanced Gradient and Pickers

When the subject has a mixture of fine, wispy edges and hard, clean edges, use a mix of localized keys and advanced gradients. Pickers are better for the fine edge areas and advanced gradient is sometimes better for the hard edge areas. You can set the state of each vertex to advanced gradient (pickers off) or localized key (pickers on) mode.

- To convert a section of a mask from advanced gradient to pickers, select one or more vertices with no pickers and enable the Picker button. Adjust the pickers as needed.
- To convert a section of a mask from pickers to advanced gradient, select one or more vertices with pickers and disable the Picker button.
- To toggle selected vertices between the two modes, use the **0** (zero) hot key.

To completely remove gradient (for hard edges):

- 1 Select the mask vertices in the area of the mask border where you want to remove the gradient.
- 2 Click any one softness vertex corresponding to one of the selected mask vertices (either an inner or outer vertex).
All the corresponding inner or outer softness vertices are selected.
- 3 From the Edit Mode box, select Scale.
- 4 Click any one of the selected softness vertices and drag until the softness border is lined up with the mask border.
- 5 Repeat for the second softness border (inner or outer).

To separate the softness border from the mask border:

- 1 Click a mask vertex, and then drag to the right to move the softness vertex out.

Applying Softness Using the Tracer

Drawing a Tracer-aided matte entails four basic steps.

To draw a Tracer-aided matte:

- 1 Analyse the image to determine which areas are appropriate for pickers and which areas are better served by advanced gradients.
- 2 Draw the garbage mask.
- 3 Assign pickers to vertices where they are needed.
- 4 Adjust the softness borders, offsets, tangents, vertices, and pickers (where used).

To analyse the image:

- 1 Examine the edges of your talent to decide which portions would benefit from advanced gradient treatment and which would respond better to localized key treatment. If your clip has colours that change greatly throughout the clip, using pickers may be difficult.

For more information, see [Applying Softness Using Pickers](#) on page 1746.

To draw the garbage mask:

- 1 In the Modular Keyer or Batch, add a context point further down the processing pipeline or processing tree. You can then use the Context view to see the effect of the matte on the result image.

NOTE When using the Tracer to pull a key from the Modular Keyer, remove the nodes before the Gmask node in the default pipeline.

- 2 Display the Garbage Mask menu.
- 3 From the View box, select Reference.
This view is a reference image of the clip (it is not affected by your changes in the module).
- 4 Draw a garbage mask around the subject and close it by clicking the first vertex drawn. Use as many vertices as required to adequately enclose the subject, but try to avoid excessive vertices. This will minimize unnecessary tweaking and manipulation later.

TIP Place more vertices in areas with variation in the background.

To assign pickers to selected vertices:

- 1 From the Softness/Tracer box, select Tracer.
The Tracer menu appears, and two softness borders (the green lines) are added to the mask.

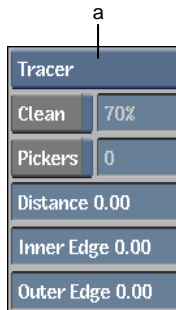

(a) Softness/Tracer box

- 2 Select the vertices to which you want to apply pickers. See [Selecting Vertices and Tangents](#) on page 1725.

3 Enable Pickers.

NOTE When one or more pickers are enabled, mask characteristics are automatically set to Outside disabled and a Colour value of 0 so that the mask will be white inside and black outside. Do not set the Outside button unless you want to reverse the effect.

A pair of pickers is provided for each selected vertex.

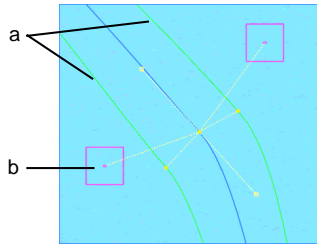

(a) Softness borders (b) Picker

- On vertices without pickers, the softness borders delineate the area where a softness gradient is applied.
- On vertices with pickers, the softness borders delineate the area to which softness is applied according to the picker values.

To fine-tune the matte:

- 1 Adjust the softness borders and mask border by moving the vertices and tangents:
 - The mask border should follow the general contour of the subject as closely as possible.
 - The outer softness border should completely surround all details that you want to include in the matte—all wispy details and edges must be within this line.

- The inner softness border should be well within the area where softness control is needed.

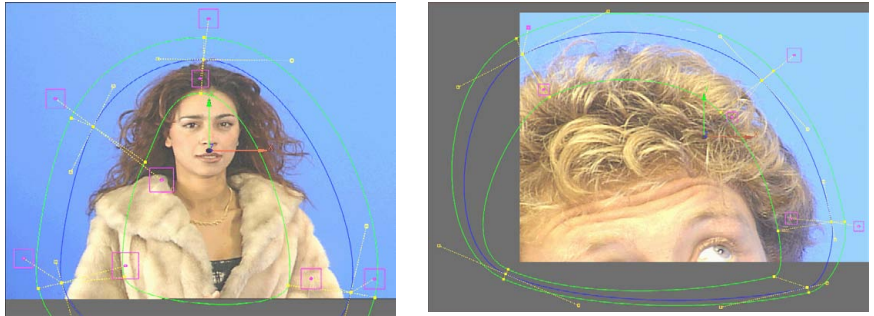

When moving tangents, you can opt to have the pickers follow the tangent movement (the default behaviour), or be independent of tangent movement. To make pickers independent of tangents, switch to Break mode and click either picker. You can animate this behaviour. See [Animating a Tracer Mask](#) on page 1752.

NOTE If the tangents are broken, the pickers are automatically unlinked from the tangents.

- 2 For each pair of pickers, one requires a sample of the area outside the mask, while the other requires a sample of the mask interior.
Place one picker outside the subject to sample values you do not want to include in the matte (for example, a blue screen). Place the other picker within the subject for a colour value sample of an area you do want included in the matte. Try to select areas where the colour values do not change too much throughout the clip.
- 3 Click Matte or Result (Matte will provide a clearer view) to see your progress.
- 4 Scale the pickers by doing one of the following:
 - Select Scale edit mode, click within the picker, and drag to the left to reduce the size or to the right to increase the size.
 - Select the picker and then drag the cursor over the Sample Size field.

- 5 Move the pickers around and enlarge or reduce them to interactively see how you can obtain the best results. This will require toggling between the Front and Matte views.

The following figure illustrates the Matte view result of the pickers placed in the previous figures.

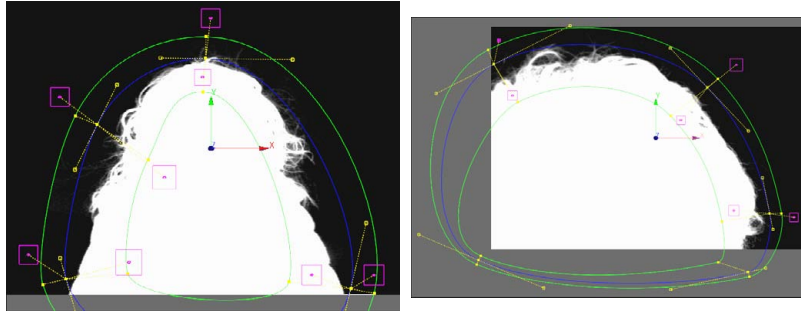

Animating a Tracer Mask

When using the Tracer, you can animate the basic vertex parameters, as well as the following additional parameters.

Parameter	Channel Folder and Name(s)	Channel Values
The position of the two softness vertices relative to the mask vertex.	border: upper = outer vertex* bottom = inner vertex*	
Whether pickers are linked to tangents or not. Linked—Pickers move with tangents. Unlinked—Pickers remain in their current position when tangents are moved.	pickers: fixed	0 = unlinked 1 = linked
The on/off status of pickers.	pickers: active	0 = off, 1 = on
The position of the pickers relative to the mask vertex.	pickers: upper = outer picker* bottom = inner picker*	

Parameter	Channel Folder and Name(s)	Channel Values
The picker size.	pickers: u-size = outer picker size* b-size = inner picker size*	
The Sample on/off status of pickers. See Animating Picker Values on page 1753.	sample: active	0 = Sample off 1 = Sample on
The interpolation mode for picker values when Sample is off. See Animating Picker Values on page 1753.	sample: interp.	0 = Constant 1 = Linear

*Channel Editor designations for “upper” and “bottom” assume the mask was drawn clockwise.

Animating Picker Values

Two options are available to control how picker values (that is, the sampled colour values) are animated: Sample On and Interpolation mode.

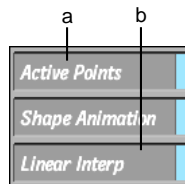

(a) Sample box (b) Interpolation button

Sample box Active resamples picker values at every frame (the default). Passive disables resampling for one or more frames. When Passive at a particular frame, the picker values previously sampled at another frame are used. It is useful to adjust the size and position of pickers at one particular frame until the result is optimal, and then apply these values to other frames. In this way, if movement in the clip in other frames causes the area being sampled to move away from the pickers, you do not need to readjust the pickers to get a good reading.

You can select Active or Passive for one or more selected pickers.

Selecting Passive works best when colour values remain fairly consistent throughout the clip. In this case, one picker sampling will often be enough for the entire clip.

Typical technique for using Sample On: one sample is used for the entire clip

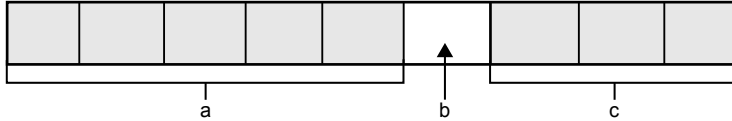

(a) Sample Off (b) Sample On (c) Sample Off

When there is more colour variation in the clip, you may need to take samples at several frames.

To use one picker sampling throughout a clip:

- 1 Choose a frame in which the colour values are representative of the average colour values found in the clip.
- 2 Select the pickers you want to sample. See [Selecting Pickers and Softness Vertices](#) on page 1725.
- 3 At that frame, make sure Active is selected from the Sample box (the default).
- 4 Set the picker values by setting their position and size until you get the optimal result.
- 5 Go to the next frame and select Passive from the Sample box.
The sample values read at the frame you chose will be used to compute the softness for all other frames in the clip.

To take samples at several frames:

- 1 Follow the steps in the previous procedure to set a picker sampling for the clip.
- 2 Starting at the first frame sampled, examine your results frame by frame (either forward or backward through the clip).
- 3 When you come to an unsatisfactory result, select the pickers you want to re-sample and select Active.
- 4 Adjust the picker position and size until you get a good result.
- 5 Go to the next frame and select Passive from the Sample box.

- 6 Continue verifying frames until you come to one that needs to be adjusted.
- 7 Repeat steps 3-5.
- 8 Repeat for the remainder of the clip.

Interpolation button Displays the interpolation between keyframes that have Active selected as the Sampling option.

- Linear (enabled): Picker values are interpolated between keyframes with active sampling. The picker values for each frame are computed based on the values of the previous and next active sampling keyframes and the proximity of the frame to those keyframes.

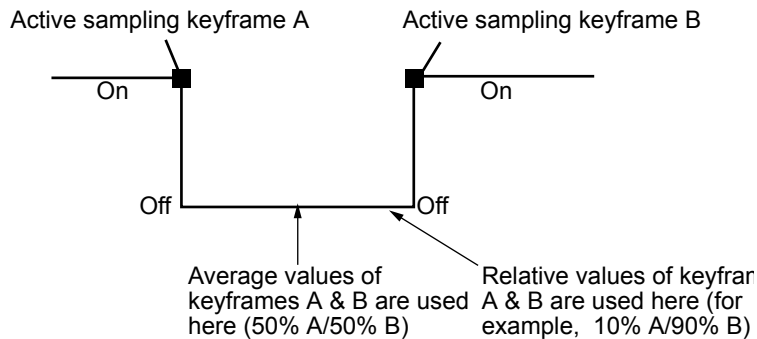

- Constant (disabled): Picker values are fixed between keyframes with active sampling. This means that the picker values at the first active sampling keyframe will be used for all subsequent frames up until the sampling is active again.

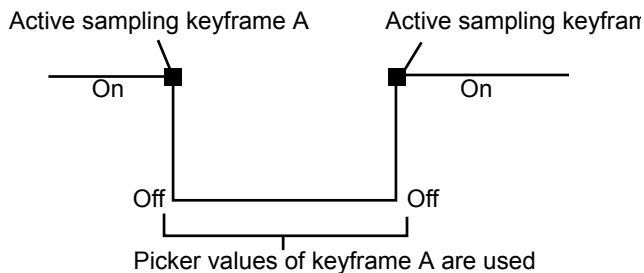

Tracking with the Tracer

Tracking with the Tracer is done using the same method as with regular garbage masks. See [Animating Masks Using Tracking](#) on page 1735.

NOTE When animating selected vertices with the Stabilizer, the vertices do the tracking, not the pickers. Once you obtain the tracking data, you will need to go back through your clip from frame 1 onwards, making adjustments to the pickers where necessary.

Troubleshooting the Tracer

Every clip has its own challenges and requires a certain amount of tweaking and fine-tuning to achieve the best results.

Problem	One of the Tracer segments (localized keys) on my matte shows noisy black and white artefacts and nothing else. What's wrong?
Possible Cause	The two pickers are sampling luma and/or chroma values that are too similar.
Solution	Try moving one of the pickers to a differently coloured area, or enlarge or reduce the size of one or both of the pickers to include more varied colour information. If there is simply no area in the clip that differs enough, you will need to use an advanced gradient for that segment.

Problem	One of the Tracer segments (localized keys) on my matte appears to be showing the black/white matte information reversed, or as a negative. What's wrong?
Possible Cause	You may have reversed the position of the two pickers.
Solution	Try exchanging the inside picker for the outside one and vice-versa.

Problem	I can't get a good colour sample from the area outside the mask edge in a certain portion of the image. What can I do?
Possible Cause	There is simply none (or not enough) of the needed colour in the immediate area of that particular picker.

Solution You can drag the picker somewhere further away from the vertex to get a better colour sample. The picker can be located anywhere on the image in order to facilitate the best possible colour sample. Do not, however, place a picker outside the image.

Problem I'm getting really nice edge detail on my matte, but I'm also getting black/white holes in my matte. Is there anything I can do?

Possible Cause This may be caused by the generation of random noise and/or artefacts.

Solution 1 Try the Clean algorithm by clicking the box labelled Clean. You may want to try several different percentages to find the optimal level of cleaning that doesn't effect your edges (the default percentage is 70%). The Clean algorithm works only with the Tracer and pickers on. If you have advanced gradient segments, they will be unaffected. The Clean command works on all vertices with pickers, whether or not they are selected. The area affected by the Clean command is the same area that the pickers affect (see [Applying Softness Using Pickers](#) on page 1746).

Solution 2 Use the inner border to isolate the problem areas.

Solution 3 Add a second garbage mask.

Problem I'm repositioning and rescaling the pickers and the matte goes from having too much softness (overly transparent) to having too little (overly opaque). What can I do?

Possible Cause The sampled colour range is either too broad or too narrow.

Solution Locate the areas that have a tendency to become too softened and the picker that is 'responsible' for this by moving the pickers until the matte results change for the worse. Include a larger portion of these softer areas in a picker box. By sampling a fuller range of chroma/luma in this area, a more uniform, averaged effect is created.

Saving Garbage Mask Setups

Garbage masks can be saved and loaded as setup files, with all vertex and animation information preserved.

To save garbage masks as a setup:

- 1 In the Garbage Mask menu, click Save to open the file browser.

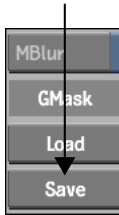

- 2 From the GMask Type box, select Save GMask.

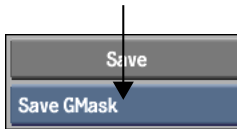

- 3 Type the name of the setup, and click Save.

Loading Garbage Mask Setups

In the file browser, when loading garbage mask setups, you can quickly navigate to either the default gmask directory or a custom directory for the current project.

In Action, you can load a garbage mask as a 3D model. See [Using Garbage Masks as 3D Geometry](#) on page 2305.

To navigate to the default or custom directory when loading garbage mask setups:

- 1 Select Default or Custom from the GMask Directory box.

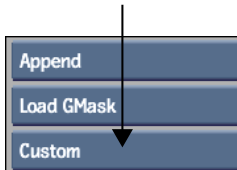

NOTE The custom directory is updated every time you navigate to a new directory.

To load a garbage mask setup:

- 1 In the Garbage Mask menu, click Load to open the file browser.

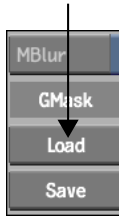

- 2 From the GMask Type box, select Load GMask.

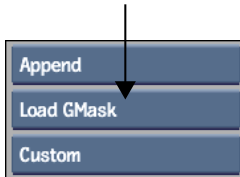

- 3 From the file browser and select the name of the setup to load.
If the GMask setup you are loading was created in a different resolution than the current project, click Scale Setup to scale the GMask.

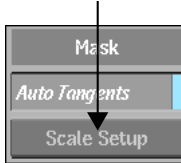

NOTE The Scale Setup button is available on the GMask Setup menu only when accessed from the Modular Keyer or the GMask node in Batch.

Preset Garbage Mask Setups

A library of preset garbage mask setups is available. To load a preset garbage mask, navigate to the `/usr/discreet/<product home>/gmask` directory and select one of the following:

- 4_point_star
- 5_point_star
- 6_point_star
- arrowhead
- cat_eye
- circle
- diagonal
- diamond

- heart
- pentagon
- square
- hexagon
- rectangle
- triangle
- keyhole
- round_rectangle
- v_shape
- oval
- s_shape

You can also view proxies for each of these setups using the file browser.

Importing and Exporting Raw Setup Files

You can import and export raw setup files for animated garbage masks. A garbage mask exported as a raw setup file includes the following information:

- The number of keyframes in the animation of the spline
- The number of vertices in the shape
- The x, y, and z position of every vertex at each keyframe

To export a raw setup file:

- 1 In the Garbage Mask menu, click Save to open the file browser.
- 2 From the GMask Type box, select Export RAW.
- 3 Type the name of the file to be exported, and click Save.

To import a raw setup file:

- 1 In the Garbage Mask menu, click Load to open the file browser.
- 2 From the GMask Type box, select Import RAW.
- 3 Navigate to the appropriate directory and select the raw setup file to import.

The raw setup file is imported into the Keyer.

To import a raw setup file in the Modular Keyer:

- 1 In the Modular Keyer, click the GMask node in the processing pipeline. See [Accessing the Garbage Mask Menu](#) on page 1710.
- 2 In the GMask menu, click Load.
The Load menu and file browser appear.

- 3 In the Load menu, select Import Raw and Default from the Load option boxes.

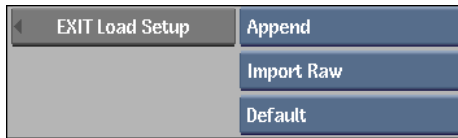

- 4 Enable Append or Replace.
- 5 In the file browser, specify the name and path of the file to import.

To export a raw setup file in the Modular Keyer:

- 1 In the Modular Keyer, click the GMask node in the processing pipeline. See [Accessing the Garbage Mask Menu](#) on page 1710.
- 2 In the GMask Setup menu, click Save. The Save menu and file browser appear.



(a) Save option box

- 3 In the Save menu, select Export Raw from the Save option box.
- 4 In the file browser, specify the name and path of the file to export.
- 5 Click Save.

Compositor and Optics

61

Topics in this chapter:

- [About the Compositor and Optics](#) on page 1763
- [Accessing the Compositor](#) on page 1764
- [Cropping the Front Clip](#) on page 1767
- [Controlling the Camera in the Scene](#) on page 1769
- [Setting Front Clip Attributes](#) on page 1770
- [Creating Motion Paths](#) on page 1773
- [Tracking Clips](#) on page 1774
- [Colour Correcting Clips](#) on page 1775
- [Processing Your Clips](#) on page 1776
- [Quick Compositing](#) on page 1777
- [Creating Glow Effects Using Optics](#) on page 1778
- [Animating Glow Effects](#) on page 1779

About the Compositor and Optics

Use the Compositor to create a composite while controlling cropping, softness, and camera, or use Quick Composite to composite quickly without these features. After creating a composite, use Optics to apply glow effects.

You can composite a front clip, a back clip, and a matte clip. The Compositor is similar to Action except that it only supports one layer and does not provide

access to the Keyer. You can scale, rotate, translate, or shear the front clip in two dimensions. You can create animations in the Compositor, apply motion paths to the front clip and the camera in the scene, as well as move and animate the camera-eye position. In addition, you can colour correct all three clips, and track points on the back clip.

Use the Quick Composite for one-step compositing of a front, back, and matte clip. Use Optics to create a glow effect in the composite. These tools are most useful in Batch for finishing effects when you have already generated mattes and fine-tuned the clips. See [Batch Processing](#) on page 1283.

Accessing the Compositor

The Compositor is accessed from the Effects menu. To access the Compositor, you must select a front clip, a back clip, and a matte clip.

To access the Compositor:

- 1 In the Main menu, click Effects.
- 2 In the Effects menu, click Compositor.
- 3 Select the front, back, and matte clips.
- 4 Select the destination.

The Compositor controls are described as follows.

Crop box Turns cropping on or off, or allows for an automatic crop. See [Cropping the Front Clip](#) on page 1767.

Front clip box Edits the front clip's visibility.

Select:	To:
Front On	Display the front clip.
Front Off	Hide the front clip.
Front Lock	Lock the front clip at the current frame in the timebar.

Back clip box Edits the back clip's visibility.

Select:	To:
Back On	Display the back clip.
Back Off	Hide the back clip.

Select:	To:
Back Lock	Lock the back clip at the current frame in the timebar.
Matte clip box Edits the matte clip's visibility.	
Select:	To:
Matte On	Display the matte clip.
Matte Off	Hide the matte clip.
Matte Invert	Invert a matte. Black areas will be made white, and white areas will become black.

Colour Corrector controls Allows you to colour correct the front, back, or matte clip. See [Colour Correcting Clips](#) on page 1775.

Stabilizer controls Accesses the stabilizer, and applies translation, rotation, and scaling settings to the composition. See [Tracking Clips](#) on page 1774.

Motion Path settings Sets motion paths for the front clip and camera. See [Creating Motion Paths](#) on page 1773.

Shadow button Places a shadow behind the front clip. See [Adding a Shadow to the Front Clip](#) on page 1772.

Texture button Enables hardware texture mapping.

Anti-Aliasing and Softness fields Controls the level of anti-aliasing. Increasing the number of samples increases the degree of anti-aliasing but also increases the processing time. Adjust the softness to affect the degree of anti-aliasing.

The jagged lines that often occur along the edges of diagonal or curved lines when processing high-frequency images such as text are the result of aliasing. Aliasing is caused by insufficient spatial sampling of the image. The process of reducing or removing the effects of aliasing by increasing the sampling rate is called anti-aliasing.

NOTE Although the cleanest images are obtained when the softness value is set to 1 or 2, higher softness values can also be used for creative effects. The best results are obtained when the softness value is set as indicated in the following table.

Anti-aliasing	Softness
1	No anti-aliasing occurs and the Softness value has no effect on the image
2	1
3	2
4	2

Resolution field Sets the resolution of image proxies while you work with a layer and play clips in the Compositor. A lower value requires more processing time to generate proxies.

NOTE When hardware texture mapping is enabled (Texture button), the value in the Resolution field no longer applies because the hardware controls resolution during interaction and playback.

Motion Update button Updates properties such as position, rotation, and colour in the scene. This button is enabled by default.

When disabled, animated objects do not move, but keep the position of their current value. Disable Motion Update when you want to copy keyframe values from one frame to another.

Play Lock button Updates the animation settings according to the frame or timebar position as you move through the clip while keeping it locked at the current frame.

Channel Snap button and Snap field Snap keyframe values in the animation curve window. When you move a keyframe in this window, it is automatically aligned to the snap grid.

The grid size is set to one unit along the X (horizontal) and Y (vertical) axes. To change the grid size along the Y-axis, change the value in the Y Snap field. You cannot change the grid size along the X-axis.

Blending box Defines the blending mode. The Blend option uses both the front and back luminance curves of the matte clip. The Add option uses only the front luminance curve. Select Add to eliminate the black fringe created when using a front clip with a black background.

Cropping the Front Clip

You can crop portions of the front clip and then use it as an effect in the composite. Alternatively, crop clips and use them temporarily to reduce processing time while working on the composite. Turn the crop box on or off any time while you work.

You can set the borders of the crop box manually using the Channel Editor, or you can use Crop Auto to get a crop box that surrounds the white area of the matte clip.

To crop the front clip manually:

- 1 From the View box, select Front to view the front clip.
- 2 From the Crop box, select Crop On.

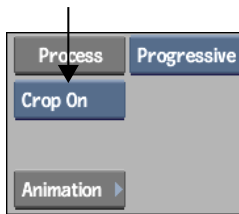

Notice the dotted crop border around the image.

- 3 Click Animation to display the Channel Editor.
- 4 Open the Object folder, and then the Crop folder.

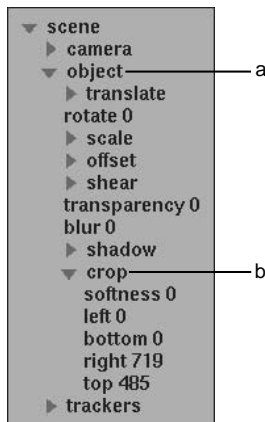

(a) Object folder (b) Crop folder

5 Select a channel.

Select:	To adjust:
Softness	The softness of the edge of the crop box.
Left	The position of the left border of the crop box.
Right	The position of the right border of the crop box.
Top	The position of the top border of the crop box.
Bottom	The position of the bottom border of the crop box.

6 Drag the cursor in the image window to change the value of the selected channel. You can also enter the values directly in the Channel Editor.

NOTE When you modify crop box borders in the image window, you can modify two borders at once. For example, when you select the left or bottom channel, you can change both borders at once. To modify a single border, use the Channel Editor.

To crop the front clip using Crop Auto:

- 1 From the View box, select Front to view the front clip.
- 2 From the Crop box, select Crop Auto.

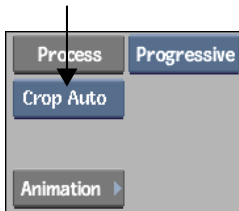

The crop box automatically surrounds the white area of the matte clip.

To reset the crop box:

- 1 In the Channel Editor, click the Crop folder to select all crop channels.
- 2 Click Reset Chn.

Controlling the Camera in the Scene

The Compositor includes a camera for the scene. You can change the camera's position, zoom, and roll. For example, animate the camera channels to simulate a camera pan or zoom.

The crosshair that appears in the image window when Result view is selected represents the point of interest.

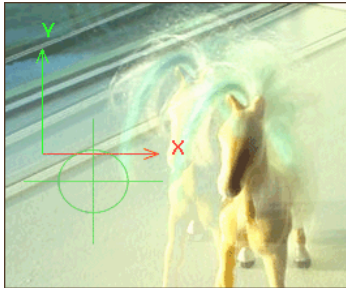

To change the camera's attributes:

- 1 From the View box, select Result to view the point of interest.
- 2 Click Animation to display the Channel Editor.
- 3 Open the Camera folder, and then the Translate folder.

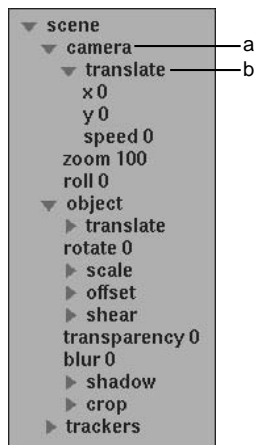

(a) Camera folder (b) Translate folder

- 4 Select a channel.

Select:	To:
X or Y channel in the Translate folder	Change the camera's position.
Speed channel in the Translate folder	Change the camera's speed.
Zoom channel	Change the camera's zoom.
Roll channel	Change the camera's roll.

- 5 Drag the cursor in the image window to change the value of the selected channel. You can also set the value in the Channel Editor. See [Animation](#) on page 1963.

NOTE To modify a single channel, use the Channel Editor. Also, you can only modify the Speed channel in the Channel Editor.

Setting Front Clip Attributes

You can move, scale, rotate, skew, and offset the front clip. You can also blur, crop, add transparency, and add a shadow to the front clip. Front, back, and matte clips can be disabled or locked at a specific frame.

To change the front clip's attributes:

- 1 Click Animation to display the Channel Editor.
- 2 Open the Object folder.

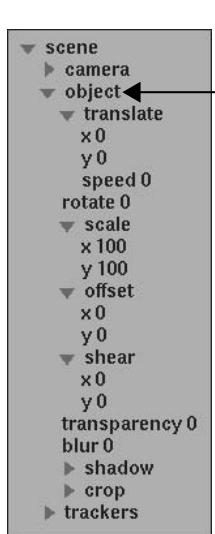

3 Select a channel.

Select:	To:
X or Y channel in the Translate folder	Translate the front clip.
Rotate channel	Rotate the front clip.
X or Y channel in the Scale folder	Scale the front clip.
X or Y channel in the Offset folder	Offset the front clip from its axis.
X or Y channel in the Shear folder	Skew the front clip.
Transparency channel	Change the front clip's transparency.
Blur channel	Blur the front clip.

4 Drag the cursor in the image window to change the value of the selected channel. You can also enter the values directly in the Channel Editor. See [Animation](#) on page 1963.

NOTE To modify a single channel, use the Channel Editor.

5 Optional: Use the Clip controls to lock the front, back, and matte clips at a specific frame or to disable them.

Adding a Shadow to the Front Clip

You can add a shadow to the front clip. You can move, scale, rotate, and skew the shadow. You can also set the shadow's colour, softness, and transparency.

To add a shadow:

- 1 In the Rendering section of the Compositor menu, enable Shadow.

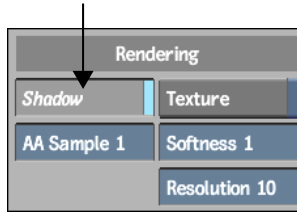

- 2 Click Animation to display the Channel Editor.
- 3 In the Object folder, open the Shadow folder.

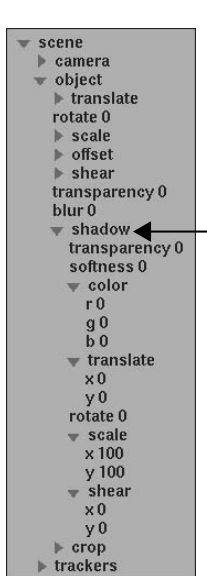

- 4 The shadow is located directly under the image. Select the X or Y translate channel or click the Rotate button and drag the cursor in the image window to move the shadow into view.

- 5 Select another channel.

Select:	To:
Transparency channel	Change the shadow's transparency.
Softness channel	Change the shadow's softness.
R, G, or B channel in the Colour folder	Change the shadow's colour.
X or Y channel in the Translate folder	Change the shadow's position.
Rotate channel	Rotate the shadow.
X or Y channel in the Scale folder	Scale the shadow.
X or Y channel in the Shear folder	Skew the shadow.

- 6 Use the other channels to create a shadow effect. You can work with the shadow in the image window or enter the values in the Channel Editor.

Creating Motion Paths

You can create motion paths to animate the translation of the front clip and the camera.

To create a motion path:

- 1 In the Motion Paths vs Explicit XYZ section of the Compositor menu, enable Object to enable the motion path for the front clip.



- 2 Enable Camera to enable the motion path for the camera.
- 3 Click Animation to display the Channel Editor.
- 4 Open the Translate folder in either the Camera or Object folder.
- 5 Select either the X or Y channel
- 6 Set the position of the front clip by dragging it in the image window. You can also do this in the Channel Editor.

- 7 In the timebar, move to a different frame.
- 8 Set the new position of the front clip by again dragging it in the image window.
A motion path appears.
- 9 Modify the motion path. See [Creating a Motion Path](#) on page 2023.

Tracking Clips

You can track one or two points on your back clip and apply that data to your front clip. Use one-point tracking to apply translation data to the front clip, and two-point tracking to apply translation and scaling and/or rotation data.

To track a clip:

- 1 Click Stabilizer.

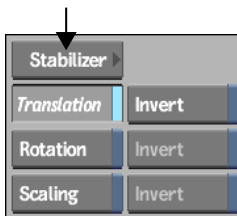

The Stabilizer appears.

- 2 Track your clip. See [Tracking and Stabilizing](#) on page 1781.
- 3 Click Return to save the analysis and return to the Compositor.

NOTE To return to the Compositor without applying the tracking data to your front clip, hold down the Return button and select Cancel.

Applying the Tracking Data

Once you track your clip, you must set how that data is applied to the front clip.

To apply the tracking data to the clip:

- 1 Enable Translation to apply the translation data to the front clip.

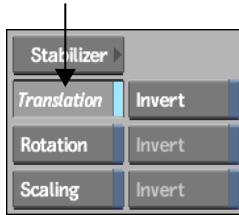

NOTE You can move the tracker box for Tracker1 in the image to adjust the tracking data.

- 2 To invert the translation data being applied to the front clip, enable Invert next to the Translation button.
- 3 To apply the rotation data to the front clip, enable Rotation.
The rotation is calculated by the relative position of the two trackers in each frame.
- 4 To invert the rotation data being applied to the front clip, enable Invert next to the Rotation button.
- 5 To apply the scaling data to the front clip, enable Scaling.
The scaling is calculated by the relative position of the two trackers in each frame.
- 6 To invert the scaling data being applied to the front clip, enable Invert next to the Scaling button.
- 7 In the Animation menu, open the Trackers folder to animate the X and Y position of each tracker.

Colour Correcting Clips

You can colour correct the front, back, or matte clip from the Compositor.

To colour correct clips:

- 1 From the View box, select Result to view the composite.
- 2 Click CC corresponding to the clip that you want to colour correct.



(a) Colour Correction controls

The Colour Corrector appears.

- 3 Modify your clip. See [Colour Corrector](#) on page 1451.
- 4 Click Return to return to the Compositor.

NOTE To reset the clip's colour values, click the corresponding Reset button.

Processing Your Clips

When you have finished setting front clip attributes, setting the camera in the scene, and animating Compositor channels, you are ready to process and render a result.

To render a clip in the Compositor:

- 1 Select either Progressive or Interlaced from the Rendering box.

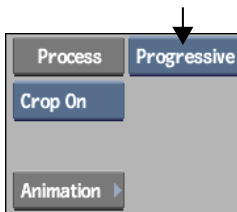

If you select Progressive, the Compositor combines the two fields and renders each frame. If you select Interlaced, the Compositor renders both fields separately. Use the Interlaced option if the two fields in the image are not properly aligned.

- 2 Select either Blend or Add from the Blending box.

The Blend option uses both the front and back luminance curves of the matte clip. The Add option uses only the front luminance curve. Select Add to eliminate the black fringe created when using a front clip with a black background.

- 3 From the View box, select Result.
- 4 Click Process.
The generated clip appears on the destination reel.
- 5 Click Exit.

Quick Compositing

Use Quick Composite for one-step compositing of a front and back clip using a matte clip.

To create a quick composite:

- 1 In the Main menu, click Effects.
- 2 In the Effects menu, click Quick Composite.
The Quick Composite menu appears.



(a) Blend Mode box

- 3 Select the blend mode from the Blend Mode box.

Select:	To:
Blend	Use subtractive blending.
Additive	Use additive blending. Select this option if the front clip has a black background, as with a computer-generated image. This option eliminates the black fringe at the edge of the front image.
FrontMin	Prevent loss of detail from the front image. For example, if the front clip is a human model, this option prevents losing details such as hair in the composite clip.

- 4 You can use the Front and Back fields to increase or decrease the luminance of the front and back clips. The values specify the gain for the

clips. Quick Composite multiplies the luminance values in the clips by the gain values you set. The resulting luminance values are clipped at the maximum and minimum values of 255 (white) and 0 (black), respectively. Gain is expressed as a percentage value. The default value of 100% has no effect on the image since the luminance values are multiplied by 1. To increase the gain, set the value above 100%. To decrease the gain, set the value below 100%.

- 5 Enable Invert Matte to invert the matte, if necessary.
- 6 Select the front, back, and matte clips.
- 7 Select the destination.
The composite clip appears on the destination reel.

Creating Glow Effects Using Optics

Use Optics to add glow effects around front clips composited over back clips. The shape of the glow is determined by the matte you select when entering Optics.

To add a glow effect to a clip:

- 1 In the Main menu, click Effects.
- 2 In the Effects menu, click Optics.
- 3 Select the front, back, and matte clips, and a destination.

The Optics menu appears. By default, Front view is enabled to speed up processing.

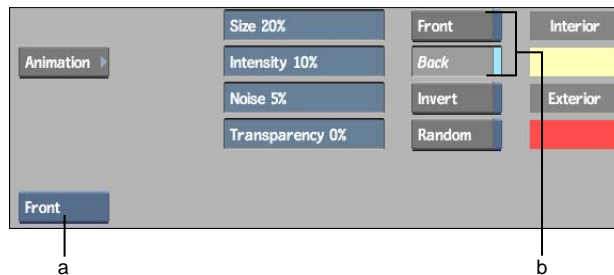

(a) View box (b) Optics Front and Back buttons

- 4 From the View box, select Result to view the glow effect.

- 5 Use the Optics Front and Back buttons to enable or disable the front and back clips. You can also invert the matte by enabling Invert.
- 6 If necessary, use the Size and Intensity fields to adjust the size and intensity of the glow effect.
- 7 Adjust the noise factor to make the glow jitter in the processed clip.
If you want to create a second processed clip where the glow jitters in a slightly different way from the first one, enable Random before processing the second clip.
- 8 If necessary, use the Transparency field to adjust the transparency of the front clip.

NOTE Make sure you enable the Optics Front button.

- 9 Use the colour pots to change the colour of the glow. Click a colour pot to display the colour picker. See [Picking Colours](#) on page 71.
The interior and exterior glow colours are blended.

NOTE To reset the glow, click the Reset All button and Confirm.

- 10 Click Process.
The generated clip appears on the destination reel.

Animating Glow Effects

You can animate the following Optics parameters:

- Size and intensity of the glow
- Amount of glow noise
- Transparency of the front clip
- Red, green, and blue values for the glow's interior and exterior colour

To display the Animation controls, click the Animation button. See [Animation](#) on page 1963.

Setting Keyframes Automatically

A keyframe consists of a channel value set at a specific frame. A keyframe is saved automatically each time you change a channel value. You can turn off the automatic keyframe feature by disabling Auto Key.

When Auto Key is disabled, you must explicitly set and remove keyframes using the Set Key and Del Key buttons in the Animation controls. See [Setting Keyframes Manually](#) on page 1977.

Tracking and Stabilizing

62

Topics in this chapter:

- [About Tracking and Stabilizing](#) on page 1781
- [Accessing the Stabilizer](#) on page 1782
- [How the Stabilizer Works](#) on page 1782
- [Working with Trackers](#) on page 1785
- [Stabilizing](#) on page 1793
- [Smoothing Out Camera Motion](#) on page 1798
- [Tracking](#) on page 1799
- [Tracking Difficult Shots and Correcting Errors](#) on page 1805
- [Setup Options](#) on page 1814
- [Copying Shift Channels](#) on page 1818
- [Importing and Exporting Data](#) on page 1819

About Tracking and Stabilizing

Use the Stabilizer to remove camera instability and motion jitter, and to track reference points in your clips. You can also use the Stabilizer to produce 2D motion or lock a bilinear surface to the clip's background. With tracking, a point or points on the clip are tracked as they move through the scene. You can then apply the resulting motion path to an object on another layer so that it follows the same path as the object you tracked.

Stabilizing is the inverse of tracking. With stabilizing, the motion path is used to shift the scene so that the point that is tracked remains fixed at one position.

Tracking and stabilizing are often processes of trial and error. It is recommended that you track or stabilize using the default settings. If the tracker box strays from its original point, you can fine-tune the analysis.

Accessing the Stabilizer

You access the Stabilizer differently, depending on how you want to track or stabilize a clip. For example, when you access the Stabilizer from the Desktop, you stabilize with one tracker. When you access from Action, you have the option to use two trackers. You need two trackers when the clip you want to stabilize has a camera roll or zoom—the second tracker enables you to track the rotation and zoom of the camera.

Access the Stabilizer from:	To:
The Desktop	Stabilize.
Action	Track or stabilize.
Keyer	Track a garbage mask.
Distort	Track vertices or the axis of a spline when warping or morphing.
Warper	Track points or an axis of a mesh when warping or morphing.
3D Tracker	Provide a 2D tracking path for 3D manual tracking.

How the Stabilizer Works

The Stabilizer uses trackers to generate tracking data. Each tracker consists of a solid box, called the *reference box*, and a dashed box, called the *tracker box*. The reference box establishes the reference point (the feature to track or stabilize) in any frame of the sequence. The tracker box indicates to the Stabilizer where to locate the reference point. The tracker box follows the frame-to-frame movement of the reference point.

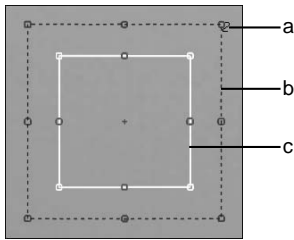

(a) Tracker number (b) Tracker box (c) Reference box

You start by selecting one or more reference points on your clip. Locate the first frame containing the movement to be tracked (the reference frame). In general, the reference frame is the first frame of the sequence. The choice of the reference point depends on whether you are tracking or stabilizing. When tracking, the reference point is a feature you want to track; when stabilizing, the reference point represents the point around which the image is stabilized. See [Selecting a Reference Point](#) on page 1785 for details. Place the reference box(es) around the selected feature(s).

Once you have set the tracker positions, start the tracking process, also referred to as analyzing the clip. During the analysis, the tracker box associated with each tracker moves as the Stabilizer looks for a pattern that matches the reference in each frame of the clip.

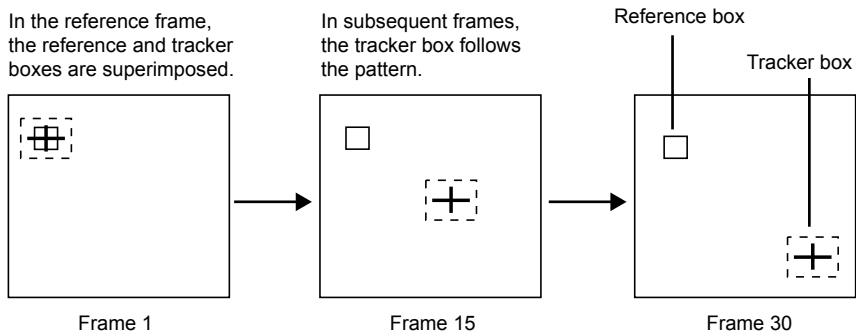

The Stabilizer calculates the difference between the position of the tracker box and the position of the reference box to produce X and Y Shift values. Shift values represent a measurement in pixels and subpixels of how much the reference point has moved.

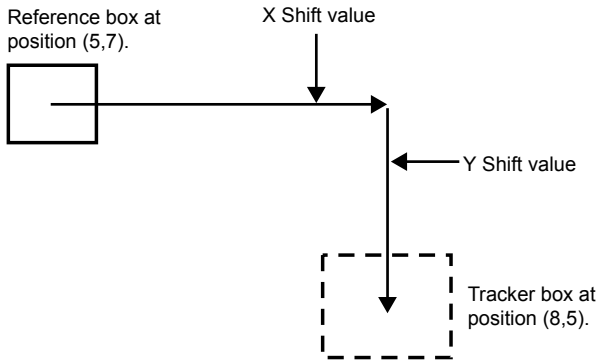

Reference position in X -	8	Reference position in Y -	5
Tracker position in X	5	Tracker position in Y	7-
Shift value	3	YShift value	2

When the analysis is complete, you fine-tune it if a tracker box has strayed from the reference it was supposed to follow. Once you are satisfied with the results, you can apply the data to the clip.

To track, the Stabilizer applies the Shift values “as is.” To stabilize, the Stabilizer inverts the X and Y Shift values in each frame of the sequence, and moves the image according to these values. This gives the impression that the reference point stays in the same position throughout the sequence. Because the image is moved during stabilization, a border appears on one or more edges, which means that you lose some pixels. The following illustrations summarize the process.

The Shift values are inverted

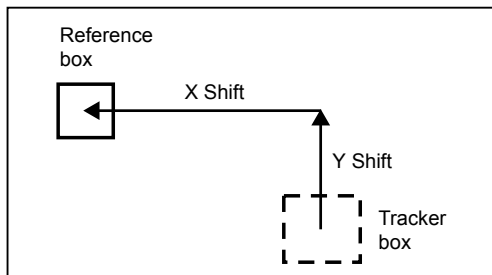

The image is moved so that the contents of the tracker box are brought back to the position of the reference box.

By default, this part of the image is cropped out.

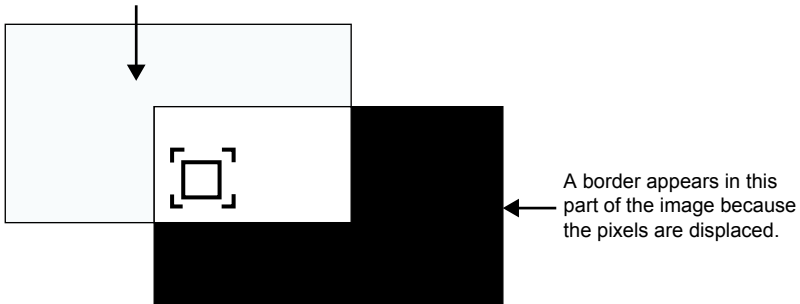

A border appears in this part of the image because the pixels are displaced.

The image is offset in the direction of the inverse Shift values.

Working with Trackers

This section provides information that is common to many procedures. It is recommended that you first read the procedure you want to perform in [Stabilizing](#) on page 1793 or [Tracking](#) on page 1799, and then consult this section when needed.

Selecting a Reference Point

A good reference point is a high-contrast pattern that has good definition both vertically and horizontally, which allows for perfect registration in both directions.

Selecting a good reference point is a process of trial and error. Play the clip several times to become familiar with the material. Ideally, you should try to find a pattern that is present in every frame. In some cases, this is not always possible and you may have to track two different patterns, track an object that disappears behind another one, or track an object that moves out of the frame.

For more information, see [Tracking Difficult Shots and Correcting Errors](#) on page 1805.

The frame you use for the reference point should be the frame where the reference image is most representative in terms of shape, size, and rotation. For this reason, you can select the reference point in the middle frame if the pattern you want to use as a reference undergoes severe rotation or scaling. In most other cases, you will position the reference box over the reference point in the first frame of the sequence.

Selecting a Tracker

You can use any of the following methods to select a tracker:

- Select any tracker by selecting **Move** or **Select** in the Edit Mode box and click the tracker box, the tracking path, or the reference box of the tracker in the image window.
- Select a tracker by clicking its corresponding button (Tracker1, Tracker2, and so on).
- Select a tracker by pressing the corresponding number key on your keyboard. You must use the number keys on the alphanumeric keyboard, not the numeric keypad.
- Select any tracker by pressing the **up** and **down arrow** keys on your keyboard.
- Select any tracker by selecting its channel in the Channel Editor.

When you select a reference box, a tracker box, or a keyframe in the image window, the timeline automatically goes to the frame where the keyframe was set.

Positioning the Reference and Tracker Boxes

When you position the reference box, the tracker box automatically follows. You can leave the boxes together if you place the reference box in the first or last frame of the clip. However, if you start the analysis on a different frame from where you position the reference box, you should position the tracker box in the first frame of the clip on the pattern you want to track. This way, the Stabilizer knows where to look for the pattern to track when you analyse the clip.

To position the reference and tracker boxes:

- 1 Go to the frame where you want to position the reference and tracker boxes.
- 2 If the tracker and reference boxes do not appear on the image, click the appropriate Tracker button and enable Active.

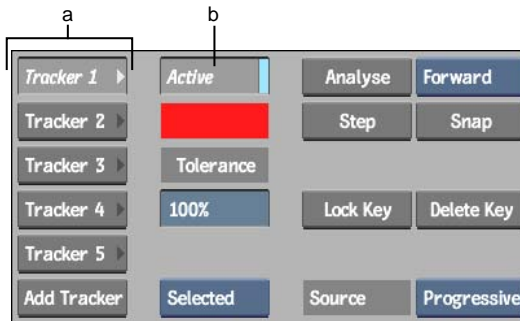

(a) Tracker buttons (b) Active button

NOTE Each tracker is automatically assigned a different colour. However, you can customize the tracker colour at any time. See [Changing the Colour of Trackers](#) on page 1818.

- 3 Click inside the reference box to select it, and drag it over the pattern you want to track.
The reference box changes into a magnifying glass. By default, the tracker box follows the reference box.
- 4 To position the tracker box on a different frame from the reference box, go to that frame and move the tracker box over the pattern to track. To move only the tracker box, click anywhere outside the reference box.

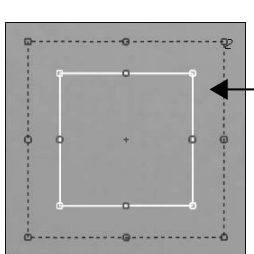

Moving the Reference

When you select the reference box in the image window, the timeline automatically goes to the frame where you set the reference. For example, if you move to frame 1 and select the reference box, if the reference is set in frame 10, frame 10 appears automatically in the image window.

To move the reference, you can:

- Reset the reference box. See [Resetting the Reference and Tracker Boxes](#) on page 1788.
- Select Add in the Edit Mode box to add a new reference.

Resetting the Reference and Tracker Boxes

By default, the tracker box moves with the reference box. If you move the tracker box by clicking in the area outside the reference box, it no longer follows the reference box. The new position is recorded in the Track X and Track Y channels in the Channel Editor and has precedence over the Shift value when the tracker box appears. If you want the tracker box to follow the reference box, you can delete the new keyframe. You can also use the Reset box to reset the reference and tracker boxes to their default position and size.

To reset the tracker box:

- 1 From the Edit Mode box, select Delete.



- 2 Click the tracker box.
The keyframe for the tracker box is deleted and the tracker box moves to the current position of the reference box.
- 3 From the Edit Mode box, select Move.
The tracker box now follows the reference box.

To use the Reset box:

- 1 Select either Reset Ref or Reset Track from the Reset box.
The reference or tracker box is reset to its default position and size.

NOTE You can also select the tracker box, enable Active for the tracker, and click Delete in the Animation menu to reset the tracker box.

Resizing the Reference and Tracker Boxes

Resize the reference box to make it surround the feature you chose to track more closely. By only including the recognizable feature in the box with no other details that may change throughout the clip, you minimize the possibility of the tracker losing the reference point.

TIP Sometimes a small reference point does not give good results. Try enlarging the box to include more of the selected feature. Note that the larger the box, the slower the analysing speed.

Resize the tracker box so that it is large enough to accommodate the most frame-to-frame movement of the reference point. For example, if the movement of the reference point is mostly horizontal, you can increase the width and reduce the height of the tracker box. If there is a large amount of movement both horizontally and vertically, increase both the width and the height of the tracker box. Note that the smaller the tracker box, the faster the analysis.

To resize the reference and tracker boxes:

- 1 Do one of the following:
 - To resize the reference box and tracker box interactively on the frame, press a resize handle on the box and drag.

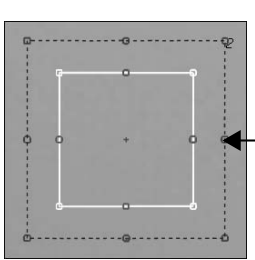

- To use the menu to move or resize the reference or tracker box for the current tracker, enter values in the Reference or Track fields.

Reference		Track	
X 360.00	Width 10	X 360.00	Width 15
Y 243.00	Height 10	Y 243.00	Height 15
Fixed <input type="checkbox"/>		Import	Export

TIP Use the image window Zoom command to get a closer view of the tracker and reference boxes.

NOTE To reset the reference or tracker box to its default position and size, select either Reset Ref or Reset Track from the Reset box.

Working with Multiple Trackers

You can change a parameter for all active trackers at once. For example, you can change the dimensions of the tracker box for all trackers or set Fixed to off for all trackers. It can be useful to hide all but a selected tracker if you want to edit its tracking path.

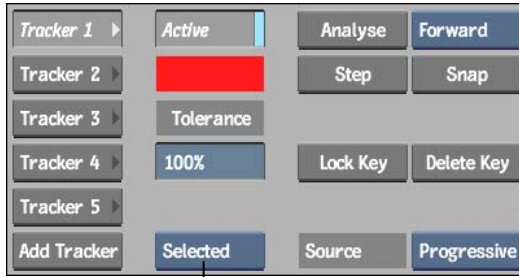

(a) Tracker Selection box

Choose:	To affect:
Selected	Only the selected tracker and show all trackers in the image window.
Solo	Only the selected tracker and hide all other trackers.
Gang	All the active trackers, except when changing the colour of the trackers.

Locating a Tracker or a Keyframe

To find the number of a tracker, click any part of its tracking path in the image window. To find the frame number associated with a particular keyframe, click the keyframe. The timeline moves to the corresponding frame.



(a) When you select a tracking path, the tracker number appears here.

Locating a Shift Channel

Use the Expand/Collapse button to locate a Shift channel quickly.

To locate a Shift channel:

- 1 Select Gang in the Tracker Selection box.

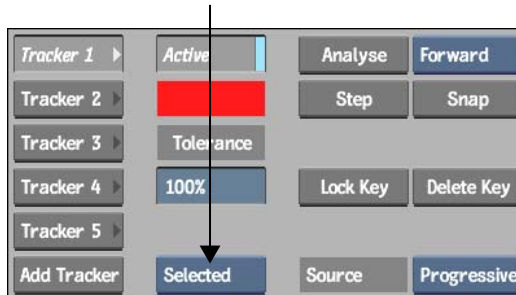

You can now change a parameter for all active trackers at once.

- 2 Click on the tracking path in the image window.
- 3 Toggle the Expand/Collapse button to Expand.

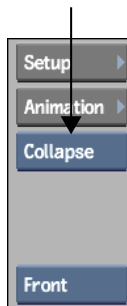

- 4 Click Animation to display the Channel Editor.
- 5 Scroll up or down to display the Shift folder.
The Shift curve of the tracker appears in the Channel Editor.

Speeding Up the Analysis

To speed up the analysis, disable the Icons and Path buttons in the Setup menu before starting. This turns off the display of the tracker and reference boxes, as well as the tracking path. Re-enable the buttons to fine-tune the analysis.

Stabilizing

There are several methods you can use to stabilize a clip.

Use:	To stabilize a clip where:
Simple Stabilization from the Desktop	There is no pan.
Jitter from the Desktop	There is pan or tilt.
Fixed X and Fixed Y from Action	There is a strictly vertical tilt or strictly horizontal pan.

A border appears at the edge of the clip you stabilize. There is a direct correlation between how much jitter you remove and the size of the border.

When you access the Stabilizer from the Desktop, you have rendering options in the Setup menu that are not available when you access the Stabilizer from Action. In particular, you can use the Crop Edges option to automatically remove the border that results from stabilizing. If you are using the Shift or Roll options, you can enable Oversampling to obtain high quality rendering. See [Rendering Options](#) on page 1814.

TIP When stabilizing clips longer than 500 frames, close the Channel Editor and disable Path in the Setup menu to significantly increase speed.

Simple Stabilization

Use simple stabilization to stabilize a clip where there is no pan or tilt.

To stabilize when there is no pan or tilt:

- 1 Enter the Stabilizer from the Desktop.
- 2 Position Tracker1 over a pattern that you want to stabilize.
- 3 To automatically remove the border at the edges of the clip, select Crop Edges from the Scaling and Shifting box. See [Scaling and Shifting Options](#) on page 1817.

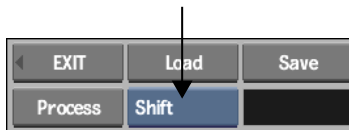

- 4 Click Analyse to generate the stabilization data.
- 5 Fine-tune the data if necessary. See [Tracking Difficult Shots and Correcting Errors](#) on page 1805.
- 6 Once you are satisfied with the stabilization, go to frame 1, make sure Tracker 1 is still active, and click Process.

Stabilizing a Clip from Action

You can import stabilizing data to lock the position of an axis in relation to a reference point on the front clip. This means that any movement in the front clip is matched by the axis. You can enter the Stabilizer from Action to stabilize an image so that the axis changes to keep the reference point fixed against the background.

To stabilize a clip from Action:

- 1 Load the clips into the Action module.
When selecting clips, keep in mind that the front clip is the image that you want to stabilize and the back clip contains the reference point you want to track. Also, the clips must be of the same resolution.
- 2 In the Axis menu for the selected media, make sure that the motion path is disabled (Path button).

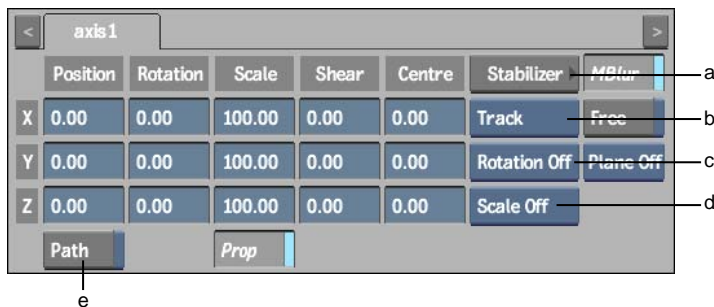

- (a) Stabilizer button (b) Stabilizer Option box (c) Tracking Rotation Option box (d) Tracking Scale Option box (e) Motion Path button

NOTE Do not move the axis from its default position at the centre of the image window before entering the Stabilizer, or else the tracking data will be overwritten. Use the offset axis to add an offset to the tracker movement instead.

- 3 In the Stabilizer Option box, select Stabilize and click the Stabilizer button. The front clip is automatically loaded into the Stabilizer and the Stabilizer menu appears.
- 4 In the Stabilizer, position Tracker1 over the reference point that you want to track.
- 5 To view the tracking result as it would appear in Action, enable Context.

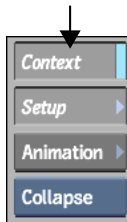

- 6 Depending on the performance of your system and the complexity of your Action setup, you can enable Linetest in the setup menu to display the context view at a lower resolution.

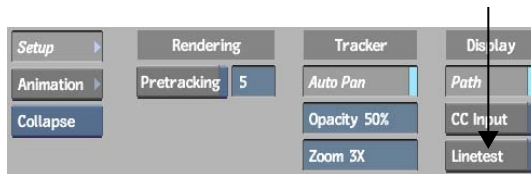

When you play the clip in Action context, you can see the front image follow the inverse movement of the reference point in the front clip.

- 7 Click Analyse to generate the translation data.
- 8 Once the analysis is complete, make sure that Tracker1 is still active, and click Return.

When you exit the Stabilizer, the X and Y Shift values for the reference position are automatically copied into the X and Y translation channels for the selected axis in the Action module.

Removing Jitter While Keeping Overall Motion

Use the Jitter option to remove the jitter from a clip while retaining the overall motion. The Stabilizer calculates the difference between an average applied to the channel by using the current Over value and the original tracking data. Applying this curve leaves only the jitter values as keyframes. Copying these curves can also be useful if you want to extract the jitter values to apply to another clip.

The Jitter option removes jitter in a clip on both the X and Y axes simultaneously, and averages the pan over time so that it appears even. Jitter control offers more flexibility than Fixed X and Fixed Y, which remove motion in one direction only. Use Fixed X and Fixed Y in simple situations, or to produce a result quickly.

Removing jitter is a process of trial and error. Try different Over values until you find one that yields good results. As a general rule, start with a large Over value over n frames to remove slow jitter, and start with a small Over value to remove fast jitter.

To remove jitter and keep overall motion:

- 1 Enter the Stabilizer from the Desktop.
- 2 Position Tracker1 over a pattern you want to stabilize.
- 3 To automatically remove the border at the edges of the clip, select Crop Edges from the Scaling and Shifting box. See [Scaling and Shifting Options](#) on page 1817.
- 4 Go to the reference frame, and click Analyse to generate the Shift data.
- 5 Click Animation to display the Channel Editor. Select the tracker number and expand the Shift folder.
The Shift curves turn white when the Shift channel is selected.
- 6 Select Keyframe from the Animation Controls box, and then enter an Over value in the Curve Value field.

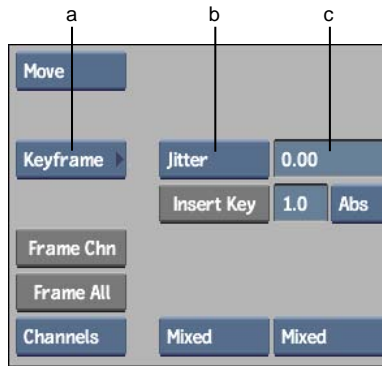

(a) Animation Controls box (b) Curve option box (c) Curve Value field

- 7 Select Jitter from the Curve option box. If Jitter was already displayed when you entered the Over value, select it again to apply the Over value. The transformation is applied to the curves. The curves show the amount of motion that the Stabilizer will remove. They should wrap around the zero point and should not be entirely flat; otherwise, the Stabilizer will not remove any jitter.
- 8 Click Result and play the clip to determine if it is stable enough. If the clip is stable enough, click Exit. To revert to the original shift data, click Paste.

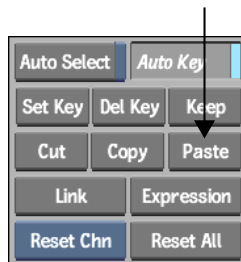

- 9 Repeat from step 7 with different Over values until you are satisfied with the results.

Removing Jitter with Fixed X and Fixed Y

The Fixed X and Fixed Y buttons remove motion in one direction only. Enable the Fixed X button to remove vertical jitter only. Movement on the horizontal

(X) axis, such as a camera pan, is not affected. Enable the Fixed Y button to remove horizontal jitter. Movement on the vertical (Y) axis is not affected.

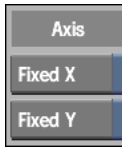

Smoothing Out Camera Motion

Use the Average options to smooth out uneven camera motion. For example, if the camera moves at a certain rate and suddenly drops or increases in speed, the Average option can stabilize the camera motion.

The Average option smooths camera motion over a group of keyframes. Use the Curve Value field to determine how much stabilizing is applied to the clip. A larger value averages camera motion over more keyframes and increases camera smoothness. Use Average to affect the Stabilizer's Shift values since Shift represents the amount of movement in a clip.

Analyse your clip to generate the initial channel data, then select the channel to apply the average to.

To smooth out camera motion:

- 1 Position the tracker(s) on your image and click Analyse.
- 2 Click Animation to open the Channel Editor and expand the Shift folder for the track(s).
- 3 Select the X or Y Shift folder and enter an average value in the Over field.
- 4 Select Keyframe from the Animation Controls box, and then enter an average value in the Curve Value field.

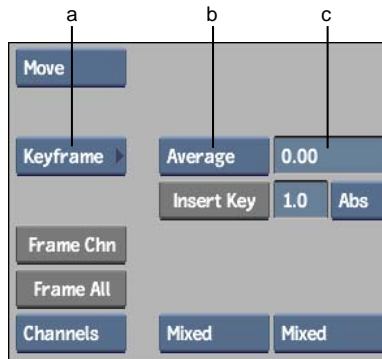

(a) Animation Controls box (b) Curve option box (c) Curve Value field

- 5 Select Average from the Curve option box.

Tracking

You can use the Stabilizer to make a clip or part of a clip track an object in another clip. For example, you can paste a logo to the side of a moving car. You can track a clip using one, two, or four reference points:

- In one-point tracking, one reference point is tracked to produce 2D motion without rotation or scaling.
- In two-point tracking, two reference points are tracked to generate translation, scaling, and rotation data that is applied to the foreground composite.
- In four-point tracking, the tracking data generated from four reference points is used to lock the four corners of a bilinear surface to the background in Action.

Since tracking involves compositing at least two clips, you open the Stabilizer from Action. When loading the clips in Action, you load the clip that contains the pattern you want to track as the back clip. The method for selecting the object that follows the pattern on the back clip is different for four-point tracking than it is for one and two-point tracking. Both methods are explained in the following sections.

Tracking from the Compositor

Since tracking involves compositing at least two clips, you open the Stabilizer from Action or from the Compositor. The procedures to track from the Compositor are similar to tracking from Action. The following sections explain how to track from Action.

One-Point and Two-Point Tracking

In both one-point and two-point tracking, you select the object that follows the pattern on the back clip by assigning the tracking data to its axis in Action.

For one-point tracking, you use only one tracker (usually Tracker1) to generate position information. For two-point tracking, you use a second tracker (usually Tracker2) to generate rotation and/or scaling information. The Stabilizer obtains this information by comparing the position of Tracker2 to that of Tracker1.

Before you select the two reference points on the back clip, note the task of each tracker:

- Tracker1 follows the horizontal and vertical translation of the reference point. You should position Tracker1 over a point on the pattern that you want to track.
- Tracker2 tracks the rotation and/or the change in size of the pattern. In the first frame, the rotation is always 0 and the scaling factor is always 100%. In subsequent frames, a rotation and/or scaling factor is added if the relative position of the two trackers changes. You should position Tracker2 over a point that represents the rotation or change in size of the pattern.

When you open the Stabilizer from Action for two-point tracking, you can select whether you want rotation information, scaling information, or both. The choice depends on the movement of the object to track and on the camera movement in the clip.

To perform one-point or two-point tracking in Action:

- 1 Load a front and back clip in Action.

The front clip contains the object and the back clip supplies the pattern that you want to track.

- In the Axis menu for the selected media, make sure that the motion path is disabled (Path button).

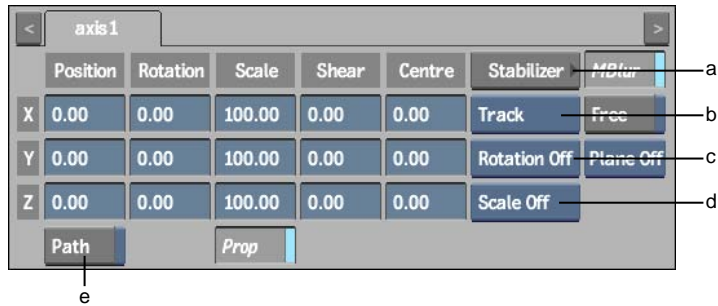

- Stabilizer button
- Stabilizer Option box
- Tracking Rotation Option box
- Tracking Scale Option box
- Motion Path button

NOTE Do not move the axis from its default position at the centre of the image window before entering the Stabilizer, or else the tracking data will be overwritten. Use the offset axis to add an offset to the tracker movement instead.

- In the Stabilizer Option box, select Track.
- From the Tracking Rotation option box and Tracking Scale option box, set the tracking options.

Select:	To:
Rotation Off and Scaling Off	Do one-point tracking.
Rotation On and/or Scaling On	Do two-point tracking.
Rotation Inv	Invert the rotation data.
Scale Inv	Invert the scaling data.

- Click the Stabilizer button.
The Stabilizer opens and the back clip appears.

NOTE If the wrong clip appears in the image window, return to Action and change the back clip to the clip that contains the pattern you want to track. For more information, see [Changing Media Clips](#) on page 2141.

- 6 Position the tracker(s) over the pattern(s) that you want to track, and click Analyze to generate the tracking data.

NOTE You can fine-tune the tracking data if necessary. See [Tracking Difficult Shots and Correcting Errors](#) on page 1805.

- 7 Once you are satisfied with the tracking, make sure the trackers you used are still active, and then click Return.

The Axis menu in Action reappears. The tracking data is applied to the front clip.

Four-Point Tracking

With four-point tracking, you use four trackers in the Stabilizer to generate tracking data for anchoring the four corners of a bilinear surface to the background clip. The bilinear surface then tracks the horizontal and vertical translation of the reference points on the background clip.

Because four-point tracking applies to surfaces, you select the object that follows the pattern on the back clip by assigning the tracking data to its bilinear surface in Action.

The markers you use must be well defined and should be planned when shooting the sequence. It is not always possible to do four-point tracking when the markers are not well defined.

To perform four-point tracking:

- 1 Load front and back clips in Action.
The front clip supplies the surface and the back clip supplies the four anchor points that you want to track.
- 2 Double-click the image node in the schematic to display the Surface menu.
- 3 Select Bilinear from the Shape box.

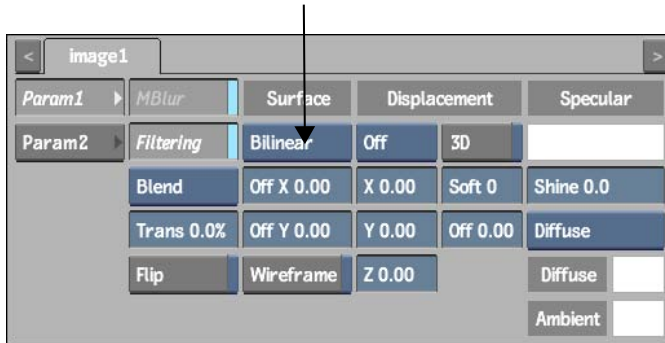

- Click the Param2 tab to display the Stabilizer button and tracking options.

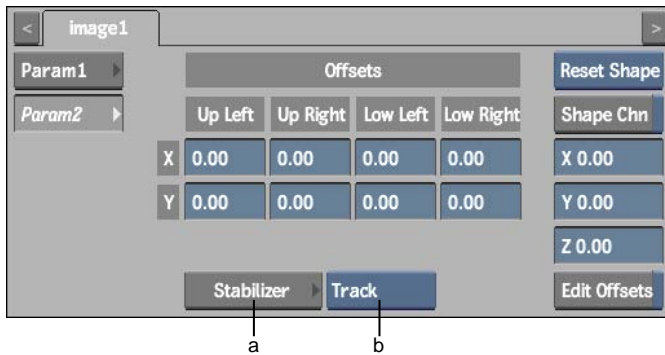

(a) Stabilizer button (b) Stabilizer Option box

- In the Stabilizer Option box, select Track
- Click the Stabilizer button.
The Stabilizer opens and the back clip appears.

NOTE If the wrong clip appears in the image window, return to Action and change the back clip to the clip that contains the pattern you want to track. For more information, see [Changing Media Clips](#) on page 2141.

- Position the four trackers on the background clip, and click Analyse to generate the tracking data.

NOTE The trackers should be positioned in order; otherwise, the result will be inverted or displaced. Place Tracker1 in the upper left area of the image to be tracked, Tracker2 in the upper right, Tracker3 in the lower left and Tracker4 in the lower right.

- 8 After the analysis is complete, make sure the trackers are still active, then click Return.

The Surface menu in Action reappears. The tracking data is automatically applied to the four corners of the bilinear surface.

Using Offsets

Instead of anchoring the entire front image to the back clip, you may only want to use a small region of the image. You can move the four corner anchor points anywhere inside or outside the front image to define the area of the front image that you want to use, and animate the resulting offsets.

If the anchor point offsets need to change from frame to frame to track a pattern on a bilinear surface, you can use the Stabilizer to generate the offsets automatically. Note that the image can be distorted when you use this method.

To generate the offsets using the Stabilizer:

- 1 Track the four anchor points on the back clip. See [Four-Point Tracking](#) on page 1802.
- 2 Display the Action Surface menu for the bilinear surface that you tracked.
- 3 In the Param2 tab, enable Edit Offsets and use the Offsets controls to edit the offsets to match the corners of your square.



- 4 Click the Stabilizer button.

The front clip appears in the Stabilizer.

- 5 Position the four trackers on the front clip in the same order as the four anchor points.
- 6 Click Analyse to generate the tracking data. After the analysis is complete, make sure the trackers are still active, then click Return.

The Surface menu in Action appears. The tracking data is automatically applied to the front clip.

You can also animate the offsets. The animation channels for the anchor point offsets are in the Offsets channel of the bilinear surface in Action Animation menu. To maintain resolution independence, each X and Y value is expressed as a percentage relative to its corresponding corner. Each anchor point offset starts with a default value of zero. For example, if you change the upper-left X offset value to 20, then the upper-left anchor point is moved inside the bilinear surface by 20%. Negative values offset the anchor points outside the bilinear surface.

You can also use the Copy and Paste buttons in the Channel Editor to copy one anchor point offset setup to another.

Tracking Difficult Shots and Correcting Errors

If the tracker box strays from the reference point that it is supposed to be tracking, incorrect shift keyframes result. If such an error occurs, you can stop the analysis, correct it, and restart it at any frame.

This section covers the different strategies you can use to track difficult shots. After trying any of the strategies, you will need to redo the analysis. Click Analyse to generate new keyframes based on the updated information you provide.

Resetting the Shift Data

Although it is not necessary, you can erase old keyframes before redoing the analysis.

To reset the shift data:

- 1 Select Reset Shift from the Reset box.

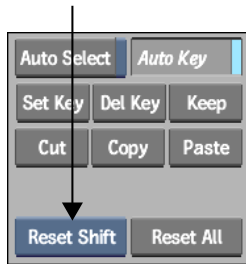

The shift value reverts to 0.

Adjusting the Size of the Tracker Box

If the Stabilizer cannot find the reference point within the boundaries of the tracker box during analysis, the tracker box will stray from the reference point and produce incorrect keyframes. Although you can manually correct these keyframes, it is easier to make the tracker box large enough to accommodate the movement of the reference point. Note that processing time increases as the size of the tracker box increases. See [Resizing the Reference and Tracker Boxes](#) on page 1789.

To adjust the size of the tracker box:

- 1 Press on the pen or hold down the left mouse button to stop the analysis.

NOTE Make sure to press below the timeline to avoid moving the tracker box.

- 2 Go back to the last good frame before the tracker box strayed from the reference point.
- 3 Adjust the size of the tracker box so that it is large enough to accommodate the largest frame-to-frame movement of the reference point.
- 4 Click Snap, and then click Analyze.

Positioning the Tracker Box Manually

When the reference point is temporarily covered by another object, position the tracker box manually.

When you manually position the tracker box, the new position is recorded in the Track X and Track Y channels of the Channel Editor. These values have precedence over the Shift X and Shift Y values.

To manually position the tracker box:

- 1 Press on the pen or hold down the left mouse button to stop the analysis.

NOTE Make sure to press below the timeline to avoid moving the tracker box.

- 2 Advance the clip to the frame where the reference point becomes visible again, and reposition the tracker box over the reference point. Click Analyse to restart the analysis at this frame.

Since the X and Y shifts are recorded as keyframes in channels, the Stabilizer calculates the translation values for the frames in which the reference point was covered. The final result will be a smooth motion.

Locking Keyframes in Place

You can lock Shift keyframes so that they stay in place even if you try to move them manually or perform an analysis. This is useful, for example, when you set keyframes manually and want to prevent Flame from overwriting them when you redo the analysis.

In the following procedure, you select the keyframes directly in the image window. However, you can also select the Shift keyframes in the Channel Editor.

NOTE You cannot lock several keyframes at once. You must lock each keyframe individually.

To lock keyframes in place:

- 1 If the tracking path does not appear in the image window, enable Motion Path in the Setup menu.
- 2 Zoom in on the image until you can see the points clearly and select the point you want to lock on the tracking path.

The tracking path becomes white when you click it, and the frame that corresponds to the keyframe appears in the image window.

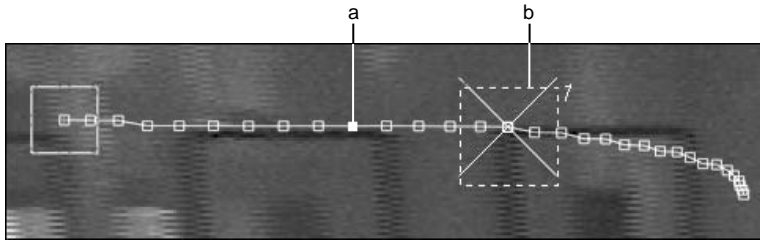

(a) The inside of locked keyframes are filled (b) The tracker box appears when you select a keyframe

- 3 Click Lock Key.

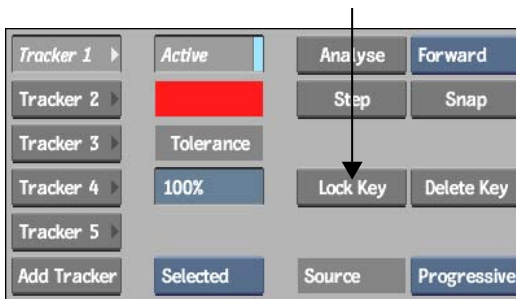

- 4 To unlock a keyframe, select it and click Unlock Key.

Changing the Reference Point

Change the reference point to another feature if the feature you have been tracking moves out of the frame, or alters such that it is no longer trackable. You should do this before the original reference point moves out of the frame. This allows the Stabilizer to calculate the offset between the two reference points and predict the position of the original reference point. If the Path button in the Setup menu is enabled, you will see the extrapolated path of the original reference point.

Change the reference point before analysing the clip.

To change the reference point:

- 1 Click Setup and then enable Path.
- 2 Select the tracker for which you want to change the reference point.

- 3 Display the desired frame in the image window.
- 4 Select Add from the Edit Mode box.
- 5 **Ctrl**-drag the reference box and position it on the new reference point.
- 6 Go to the first frame of the sequence and click Analyse.

Finding the Best Tolerance Value

The Tolerance value determines how much discrimination the Stabilizer uses in matching the reference point from frame to frame and in setting a keyframe for that frame. At 100% tolerance (no discrimination), almost anything is considered as a match and a keyframe is set. At 0% tolerance (complete discrimination), only a perfect match is accepted.

If the reference point becomes hidden by another object, you can use the Tolerance value to make the tracker ignore the reference point in parts of the clip where it is hidden, then continue tracking it normally when it reappears. Choosing a good Tolerance value reduces the need to manually reposition the tracker box during analysis.

TIP You can also adjust the tolerance to make a desirable keyframe that has been filtered out reappear.

To find the best Tolerance value:

- 1 Click Setup and then enable Path to view the tracking path.
- 2 Analyse the clip with full (100%) tolerance.

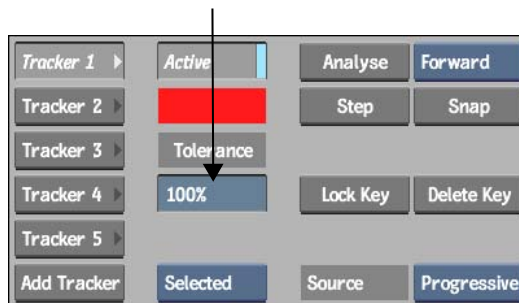

- 3 Go to the first frame where the reference point is hidden by another object and adjust the tolerance value until the crosshair reappears in the tracker box.

The crosshair reappears when there is a keyframe.

- 4 Go to the first frame in the sequence and click Analyse.

Once you determine the optimal tolerance value, further analysis automatically discards the undesirable keyframes, and the position of the reference point is extrapolated until the reference point reappears.

Analysing Backward

Analyse the clip backward when the pattern you want to track grows larger or when it is off screen at the beginning of the clip.

NOTE You cannot analyse backward if you need to change or snap the reference. In this case, reverse the clip without interpolation before entering the Stabilizer and analyse it forward.

To analyse backward:

- 1 Select Backward from the Direction box.

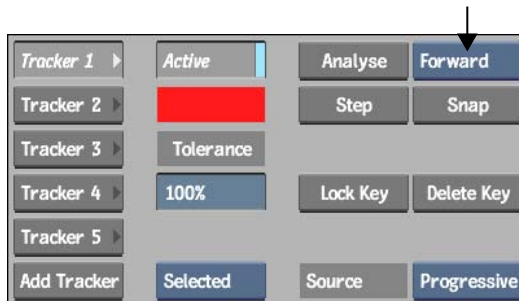

- 2 Go to the last frame of the sequence.
- 3 Position the reference and tracker boxes.
- 4 Click Analyse.

Tracking Manually

Track manually when the pattern you are tracking disappears behind an object for several frames, moves out of the frame, or is extremely difficult to track.

Tracking a Pattern that Disappears

Tracking a pattern that disappears is easier to do when the Fixed option is off. However, the results may not be as accurate because any small errors you make in positioning the tracker box are compounded when Fixed is off. Leave Fixed on when possible.

To track a pattern that disappears:

- 1 Go to the last keyframe before the reference point disappears.
- 2 Click Snap to redefine the reference point on this frame.



- 3 Select Add in the Edit Mode box.
- 4 **Ctrl+Shift**-drag the tracker box to the required position in the current frame.

Use the reference image you see in transparency as a guide to find the new position. A keyframe is set and the timeline advances one frame forward or backward when you release the pen. The direction of the timeline depends on the setting in the Direction box.

NOTE If you do not see the reference image in transparency, set the Opacity option in the Setup menu to approximately 50%.

- 5 Repeat step 4 as necessary.

TIP Lock the keyframes as you add them.

Tracking an Erratic Pattern Manually

Using this method, you create part of the tracking path manually. You can either add a keyframe in each frame, or add keyframes in significant frames of the clip and extrapolate the curve for the other frames.

You must delete unwanted keyframes before you can add new ones.

TIP To go to the desired frame, select Move in the Edit Mode box and click on the corresponding keyframe in the image window.

To track an erratic pattern manually:

- 1 Erase any bad keyframes by selecting Delete in the Edit Mode box and clicking the bad keyframes in the image window.
- 2 Go to the last good frame before the frame where you want to start tracking manually.
- 3 Click Snap to redefine the reference on this frame.

NOTE If you are tracking a whole clip manually, position the reference box on the pattern to track.

- 4 Select Add from the Edit Mode box.
- 5 Select one of the following options from the Interpolation Mode box.

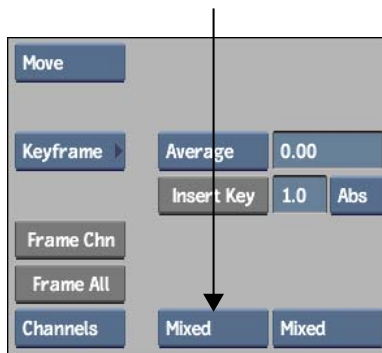

- To set critical keyframes only, select Hermite.
 - To set keyframes on every frame, select Linear.
- 6 Add a keyframe by holding **Shift** and dragging the tracker box over the reference point.

You should see the reference image in transparency. The keyframe is added in the following frame when you release the mouse button or lift the pen.

NOTE If you do not see the reference image in transparency, make sure you have defined a reference and check that the Opacity is set to approximately 50% in the Setup menu.

- 7 Repeat step 6 for every frame where you want to define a keyframe.
- 8 Play the clip and adjust the tracking path by moving or adding keyframes.

Analysing One Frame at a Time

Analysing one frame at a time is useful for difficult shots because you can adjust the position of the tracker after each frame. Click the Step button to analyse a single frame and advance to the next frame.

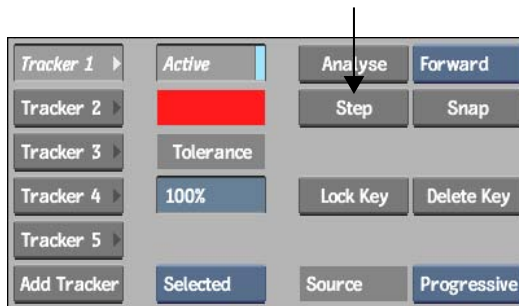

Editing the Stabilizer Channels on the Image

You can edit the tracker channels directly on the image instead of editing them in the Channel Editor. Note that the curve on the image shows the X and Y components together and not separately like in the Channel Editor. The tracking path on the image shows the actual displacement of the tracker box.

To edit the curve directly in the image window, Path must be enabled in the Setup menu. When you select a keyframe on the curve, the timeline goes to the frame that corresponds to the keyframe. When you select the reference box, the timeline goes to the frame where you set the reference.

When you edit the tracking path in the image window, all the options in the Edit Mode box are available except Rect Zoom, Zoom, and Pan.

Tracking a Degraded Copy of the Clip

If other options do not work, you can try degrading a copy of the image until the contrast of the pattern to track is high enough. You then generate tracking data from this copy, save the setup, and apply it to the original clip. Try the following methods for degrading the clip:

- Saturate the colours in the Colour Corrector.
- Increase the contrast in the Colour Corrector.
- Apply filters (for example, Emboss).
- Remove film grain using Degrain.

Setup Options

Use the options in the Stabilizer menu to specify preferences for tracking and the user interface. Use the options in the Setup menu to specify general and rendering preferences.

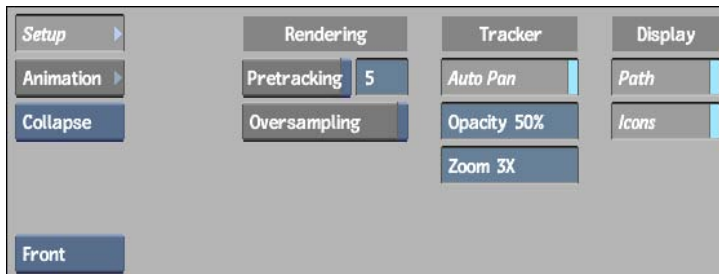

Rendering Options

Use Pretracking to preview the motion path before processing, and Oversampling to use high-quality subpixel image adjustment.

Pretracking

Before analysing, you can use the Pretracking option in the Setup menu to preview the motion path for a specified number of frames. You can then adjust the tracker position, if necessary, to find the best reference point. The Pretracking option applies only to the selected tracker, regardless of whether you selected Solo, Selected, or Gang in the Tracker Selection box. If you move or resize a tracker with Pretracking enabled, the next frames are analysed.

To pretrack a clip:

- 1 Position and select a tracker.
- 2 In the Setup menu, make sure that Path is enabled. If it is disabled, Pretracking is not available.
- 3 Enter the number of frames to pretrack.

NOTE If you enter a number larger than the length of the clip, only existing frames are pre-tracked.

- 4 Enable Pretracking.
The motion path appears.

NOTE Frames, not fields, are pretracked. If you are in Fields mode, frames will be pretracked.

Oversampling

Use Oversampling to toggle high-quality subpixel image adjustment on and off:

- When Oversampling is off, texture memory is used.
- When Oversampling is on, a high-quality subpixel shift algorithm is used. The resulting image is sharp.

After you stabilize a clip with Oversampling on, rotoscope it in Paint to remove the border that appears at the edges. Avoid using Action (or any other component that uses texture memory) to do this because you will lose the benefits of Oversampling.

NOTE You cannot use the Oversampling and Crop Edges options together. If you select Crop Edges, texture memory is used even if Oversampling is on.

Tracker Options

Use the Tracker options to help you work with trackers in the image window.

Auto Pan button When you zoom in, the selected area may move out of the image window. Enable the Auto Pan option so that the part of the image that is selected stays in the image window when you zoom in.

Opacity field The reference image (the image where you placed the reference box) appears in transparency when you select a keyframe. Adjust the opacity of the image to make it more or less transparent. When the opacity is set to 0, the reference image does not appear. When the opacity is set to 100, the reference image is completely opaque.

Zoom field By default, the reference box turns into a magnifying glass when you select it. Increase or reduce the magnification factor in the Zoom box.

Zoom:	Result:
0	No zooming. The crosshair appears in the tracker box after you analyse the clip.
1	No zooming and no crosshair.
2, 3, 4, 5	A magnification factor of 2, 3, 4, and 5, and a crosshair in the tracker box.

Display Options

Use the display options to enable or disable the motion path and icons in the image window.

Path button The tracking path is the path that the reference point makes as it changes position from frame to frame. By default, the tracking path appears in the image window. You can turn it off by disabling the Path button.

Icons button The tracker and reference boxes appear in the image window when a tracker is active. You can hide them by disabling the Icons button. This is useful when working with many trackers.

Other Tracking Options

Use these options in the Stabilizer menu to determine whether to scale or shift a stabilized image, to track in frame or field mode, and to fix the reference box.

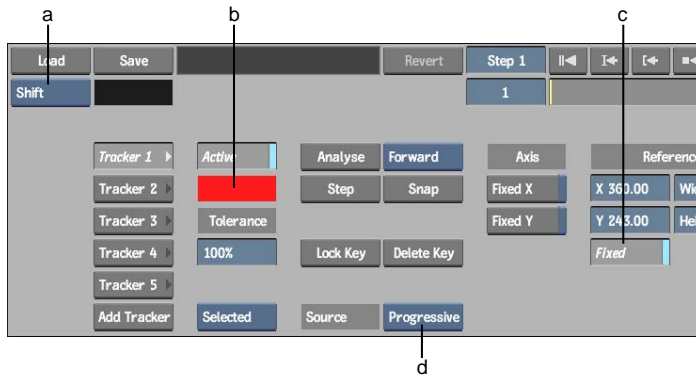

(a) Scale and Shift Option box (b) Tracker Colour pot (c) Fixed Reference button
(d) Source Option box

Scaling and Shifting Options

When a clip is stabilized, the image is shifted. You can choose any of the following from the Scale and Shift Option box to fill or remove the area where the image has been shifted.

Select:	To:
Shift	Use a colour to fill the area. Use the adjacent colour pot to pick the colour.
Roll	Wrap the image around to fill the area.
Letterbox	Rescale the longest edge of the image to fit into the frame and fill the rest of the image with a black border.
Crop Edges	Rescale the shortest edge of the image to fit into the frame and crop the longest edge.
Fill	Rescale both dimensions of the image independently to make it fit into the frame. Note that this can change the aspect ratio.

Tracking on a Field or Frame Basis

By default, the Stabilizer works in Progressive (frame mode). Select Interlaced from the Source Option box mode when working with interlaced images, or with images that display a lot of field jitter. In Interlaced (field) mode, the Stabilizer sets two keyframes for every frame: one for the even field and one for the odd field, and an asterisk appears in the image viewer's current frame display to indicate the second field for each frame.

Fixed Reference

Normally, you use the Stabilizer with the Fixed Reference button enabled. Throughout the analysis, the tracker box follows the movement of the reference point that you specified in the reference frame.

You may want to track a pattern that changes considerably from the first frame to the last frame in the clip. For example, the pattern may be rotating or may change size or shape. In this case, disable the Fixed Reference button. The reference point is then updated in each frame. In each frame of the analysis, the Stabilizer looks for the reference point from the previous frame.

NOTE Unless you are in Gang mode, you must set the Fixed Reference button for each active tracker individually.

Changing the Colour of Trackers

When you add a new tracker, the system automatically assigns it a unique colour so that you can easily distinguish between multiple trackers. You can change the colour of an individual tracker or of all the trackers at once.

To change the colour of the tracker:

- 1 Click the Tracker button that corresponds to the tracker you want to change.

TIP To change all trackers, select Gang in the Tracker Selection box.

- 2 Click the Tracker colour pot.
- 3 Select a colour with the colour picker.
- 4 Click in the Tracker colour pot to apply the new colour to the tracker.

Copying Shift Channels

Using the Channel Editor, you can copy a tracker's Shift channel values and paste them into any other channel in any module. For example, you can copy jitter values to the X and Y position channels of an axis to add realism to a static scene, or to a channel to add noise.

There are two Copy buttons in the Stabilizer. One takes the aspect ratio of the clip into account and the other one does not.



(a) This Copy button takes the aspect ratio into account (b) This Copy button does not take the aspect ratio into account

The coordinate system that the Stabilizer uses for mapping pixels on the image differs from the system used by other modules. In the Stabilizer, the pixel with coordinates (0,0) is in the lower-left corner, while in most other modules it is in the centre of the screen. When pasting shift curves to the channels of an axis, use the Copy button that takes the aspect ratio into account. Since this button also accounts for the differences in pixel coordinates between modules, it ensures that the values are mapped properly.

To copy and paste a shift channel:

- 1 In the Channel Editor, open the folder of the tracker whose shift values you want to copy.
- 2 Select the X or Y Shift channel, or the entire Shift folder to select both X and Y Shift channels.
- 3 Click one of the Copy buttons, depending on whether or not you want to maintain the aspect ratio.
- 4 If necessary, load the clip to which you want to apply the Shift values into the appropriate module.
- 5 Open the folder of the channel to receive the copied shift values and select the appropriate channel(s).
- 6 Click Paste.

Importing and Exporting Data

Import and export tracking and shift data values to an ASCII file using the Import and Export buttons located in the Track and Shift areas of the Stabilizer menu.

Track		Shift	
X 360.00	Width 15	X 0.00	Copy
Y 243.00	Height 15	Y 0.00	
Import	Export	Import	Export

The tracking data specifies the X and Y position of the tracker box in relation to the origin point of the image; these are absolute coordinate values. The origin point has coordinates (0,0), and is located at the lower-left corner of the image.

The shift data specifies the difference between the position of the reference box (0,0) and the position of the tracker box in the current frame. These are relative coordinate values.

Both the Tracking values and the Shift values are formatted as follows:

frame#: X position, Y position

NOTE If the position of the reference box is changed during the analysis, the offset is compensated for and the exported tracking data still shows a continuous tracker path.

Distort

63

Topics in this chapter:

- [About Distort](#) on page 1822
- [Accessing the Distort Menu](#) on page 1825
- [Using Distort's Views and Clip Display](#) on page 1830
- [Creating Splines](#) on page 1833
- [Editing Splines](#) on page 1839
- [Using Distort's Schematic](#) on page 1841
- [Animating and Tracking Splines](#) on page 1854
- [Blending Clips](#) on page 1858
- [Interpolating Features](#) on page 1859
- [Refining Distortions](#) on page 1860
- [Filling in Gaps at Edges of Distorted Clips](#) on page 1866
- [Warping Example](#) on page 1867
- [Distort Animation Channels](#) on page 1868
- [Using Distort in Batch](#) on page 1872
- [Saving Preferences](#) on page 1875
- [Saving and Loading Distort Setups](#) on page 1876

About Distort

Use the Distort module to warp a clip and create morphs between two clips. Both of these effects are created using splines, which are drawn and animated in a similar way to garbage masks.

Warping in the Distort Module

Warp is created by drawing a source spline, and then offsetting a second corresponding destination spline. When you draw a source spline, an identical destination spline is automatically created. When you move the destination spline, the offset of the destination from its source spline is what warps the clip. For example, you can draw a source spline around the eye of an actor, and then edit the points of the corresponding destination spline to make the eye bulge.

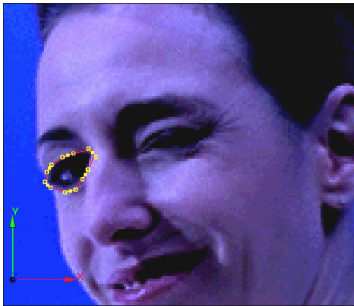

Source spline drawn around eye

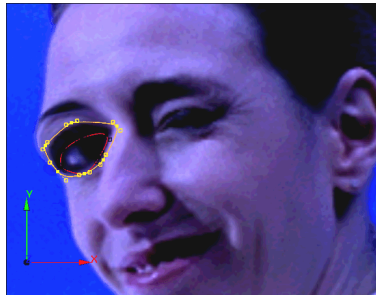

Offsetting destination spline creates warp

Images courtesy of Behavior Communications Inc.

Distort Warping Workflow

The general warping workflow in the Distort module includes the following steps.

Step:**Refer to:**

1. Load clips into the Distort module. [Accessing the Distort Menu](#) on page 1825.
-

Step:	Refer to:
2. Draw a source spline.	Drawing Splines on page 1834.
	TIP Use Distort's schematic as you work with splines to help organize your work. See Using Distort's Schematic on page 1841.
3. Edit the source spline.	Editing Splines on page 1839.
4. Animate the source spline.	Animating and Tracking Splines on page 1854.
5. Unlink the destination spline from the source to enable warping.	Linking and Unlinking Splines and Axes on page 1838.
6. Edit the destination spline.	Editing Splines on page 1839.
7. Animate the destination spline.	Animating and Tracking Splines on page 1854.
8. Refine the warping effect.	Refining Distortions on page 1860.
9. Set what appears at edges of clip if the distortion effect pulls the clip away from the border, revealing empty space, or the background clip.	Filling in Gaps at Edges of Distorted Clips on page 1866.
NOTE Repeat this workflow for each warped element of the clip.	

Morphing in the Distort Module

Morphs are created by creating corresponding splines on two clips and linking them together. You then set interpolation values controlling how the features contained in the first set of splines morph into the features contained in the second set of splines. This method is called source interpolation. Finally, you blend the two clips over time to complete the morph. For example, you can draw splines around the outline of an actor and each of the actor's facial features. Then copy these splines onto a second clip containing the actor to whom the first actor will morph into. Edit the copied splines to more accurately contour the features of the second actor, link the corresponding splines, and then blend the two clips to complete the morph. Both sets of splines, those

on the first clip, and those on the second clip, can be animated. Additionally, you can edit and animate the interpolated splines.

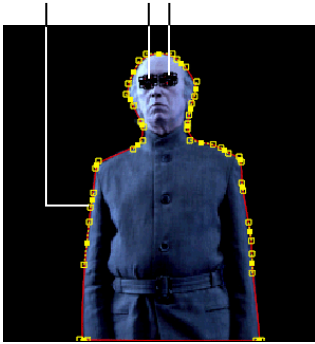

Source splines drawn on actor

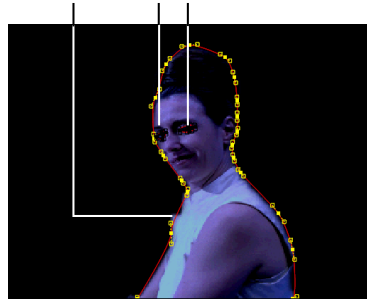

Corresponding splines on second actor are linked

Images courtesy of Behavior Communications Inc.

Distort Morphing Workflow

The general morphing workflow in the Distort module includes the following steps.

Step:	Refer to:
1. Load clips into the Distort module.	Accessing the Distort Menu on page 1825.
2. Draw a source spline on the Input1 clip.	Drawing Splines on page 1834. TIP Use Distort's schematic as you work with splines to help organize your work. See Using Distort's Schematic on page 1841.
3. Edit the Input1 source spline.	Editing Splines on page 1839.
4. Animate the Input1 source spline.	Animating and Tracking Splines on page 1854.
5. Display the Input2 clip.	Toggling Between Inputs on page 1832.
6. Copy the Input1 spline, then toggle the copied spline to become an Input2 spline.	Copying Nodes on page 1853 and Toggling Spline Nodes from One Input to Another on page 1851.
7. Edit the Input2 source spline.	Editing Splines on page 1839.

Step:	Refer to:
8. Animate the Input2 source spline.	Animating and Tracking Splines on page 1854.
9. In the Distort schematic, link the spline on the Input1 clip with the spline on the Input2 clip.	Linking Source Nodes on page 1853.
10. Set Blend and Interpolation values.	Blending Clips on page 1858 and Interpolating Features on page 1859.
11. Refine the morphing effect.	Refining Distortions on page 1860.

NOTE Repeat this workflow for each morphed feature you want to correlate from the Input1 clip to the Input2 clip.

Mesh-Based Warps and Morphs

While the Distort module uses splines to define features of a clip you want to warp or morph, you can also use the Warper module. Instead of splines, the Warper uses meshes to define affected features for similar warping and morphing effects.

Mesh-based warps and morphs created with the Warper can be more time-consuming since meshes have many more points to work with and usually cover the entire clip. The Warper can be useful, however, because you have more direct control over the parts of the clip being altered since you manipulate the mesh directly.

For more information, see [Warper](#) on page 1877.

Accessing the Distort Menu

Distort is accessible from both the desktop and Batch.

In Batch, you can create a more convincing morph, for example, by animating colour transitions between the first and second clips using Colour Corrector nodes.

To access the Distort menu from the desktop:

- 1 From the Main menu, click Effects, then Distort.

- 2 From the Distort Clips Selection box that appears, select the clips or mattes you will use.

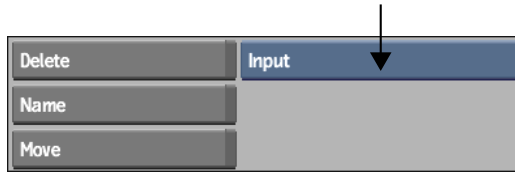

Select:	To load:	To produce:
Input	One input clip only	A warp of a single clip.
Input Matte	An input clip with its matte	A warp of a single clip using a matte over a black background. A warped matte is also produced.
Input Matte Bg	An input clip with its matte, as well as a background	A warp of a single clip using a matte over a background clip. A warped matte is also produced.
Input1 Input2	Two inputs	A morph from one clip to another over a black background.
Input1 Input2 Bg	Two inputs, as well as a background	A morph from one clip to another over a background clip.
Input1 Input2 Matte1 Matte2	Two inputs with their respective mattes	A morph from one clip to another over a black background. A morphed matte is also produced.
Input1 Input2 Matte1 Matte2 Bg	Two inputs with their respective mattes, as well as a background	A morph using two clips and their mattes on a background clip instead of on black. A morphed matte is also produced.

- 3 Select clips from the desktop reels.

For example, if you selected Input1 Input2 Matte1 Matte2 Bkg to morph between two clips, select clips as follows:

- The clip where your morph originates is Input1.
- The clip containing the subject that will be morphed to is Input2.
- The matte for Input1 is Matte1.

- The matte for Input2 is Matte2.
 - The background clip.
- 4 Click a destination reel.
The Distort menu appears.

To access the Distort menu from Batch:

- 1 In Batch, drag and drop the Distort node from the node bins to the schematic.
- 2 Connect the node to a clip or image. You can connect up to five sockets: Input1, Input2, Matte1, Matte2, and Background. The Input2, Matte1, Matte2, and Background clips are optional.
- 3 Double-click the Distort node.
The Distort menu appears. The Distort node outputs a warped or morphed result and a warped or morphed matte.

The Distort controls are described as follows.

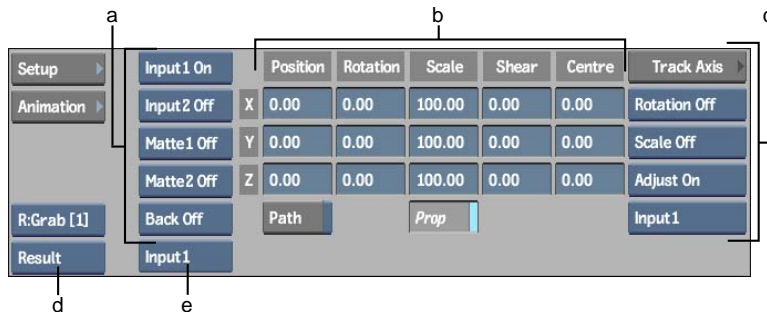

(a) Clip Display buttons (b) Axis controls (c) Axis Stabilizer controls (d) View box (e) Input box

Clip Display buttons Controls which clips, of those you load into Distort, are displayed. Use the Clip Display buttons to produce various effects, or to toggle on or off clips and mattes to facilitate your work.

Axis controls Edits the axis position, scale, and shear value of a spline.

Axis Stabilizer controls Gives access to the Stabilizer, for automatically tracking motion in the axis.

View box Sets the view in the image window. Two views available from this box, Input and Matte, each correlate with two distinct views, Input1 and Input2, or Matte1 and Matte2. You toggle between the input or matte views using the Input box.

Input box Toggles between the Input1 and Input2 clips. If Input is selected in the View box, this box toggles between Input1 and Input2. If Matte is selected in the View box, this box toggles between Matte1 and Matte2. If Result is selected in the View box, this box toggles between showing the splines for Input1 and Input2 drawn on top of the result.

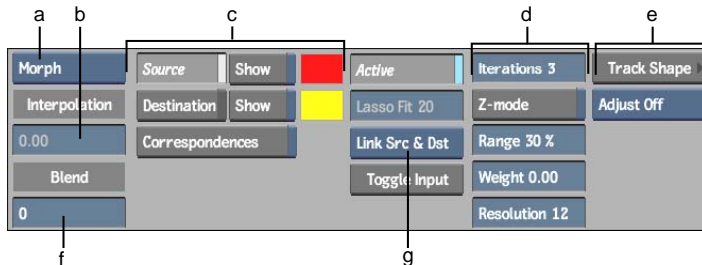

(a) Warper button (b) Interpolation field (c) Spline Display controls (d) Refining controls (e) Shape Stabilizer controls (f) Blend field (g) Link box

Warper button Choose to display the Warp or Morph menu.

Interpolation field Controls the percentage the Input1 spline mixes with the Input2 spline when source splines are linked for source interpolation. You independently set an interpolation value for each set of linked Input1 and Input2 source splines.

Blend field Use to blend between the Input1 and Input2 clips when morphing.

NOTE The Blend field is only available from the Morph menu.

Source button Displays source splines for manipulation. Also use to display the unwarped input clip.

Source Show button Displays source splines for reference when working with destination splines.

Source colour pot Sets the colour of all source splines.

Destination button Displays destination splines for manipulation. Also use to display the warped input clip.

Destination Show button Displays destination splines for reference when working with source splines.

Destination colour pot Sets the colour of all destination splines.

Correspondences button Click to display correspondence points and connector lines, which indicate how the source spline maps to the destination spline for both warps and morphs. You can add, edit, animate, and delete correspondence points. The more correspondence points a spline has, the greater effect it has on the overall warp.

Active button Allows greater control over an animated spline by toggling selected vertices on and off.

Lasso Fit field Adjusts the number of vertices in freehand segments of a spline. Increasing the value decreases the number of vertices, while decreasing the value increases the number of vertices. Only segments of the spline drawn using freehand mode are affected, while segments created by simple clicks remain unaffected. The Lasso Fit parameter loses its influence over freehand segments of a spline if you edit vertices.

Link box Controls whether source and destination splines are linked together or manipulated independently. Set this to Lnk Src & Dst to keep the source and destination splines linked as you draw and animate the source spline. Set this to Enable Warping to control the destination spline independently to create a warp. You can also independently link and unlink the axis nodes that are the parents of a source spline and its corresponding destination spline.

Toggle Input button Changes a spline from an Input1 spline to an Input2 spline, and vice versa. This is useful when you have animated a spline on one input and wish to apply it to the other.

Iterations field If Z-mode is disabled, the maximum distance of the distortion is limited to avoid overlapping. When there is a large distance between a source and destination spline, you will achieve better results by increasing the number of iterations. For smaller warps or morphs, there is no advantage in using a greater number of iterations—it will increase processing time unnecessarily.

Z-mode button Enable Z-mode to allow overlapping in your image to create 3D-like effects where parts of the image are “pulled” over other parts.

NOTE When Z-mode is enabled, the Iterations field is disabled.

Range field Determines how big a region is affected by the warping effect. The greater the value, the larger the portion of the image affected. A value of

100% affects the entire image, a value of 33% affects one-third of the image, for example.

TIP The distortion grid can be displayed by enabling Draw Grid in Distort's Setup menu. This can be useful when working with the Iterations and Range fields.

Weight field Sets a relative weight to the selected spline to control its influence. For example, you can set a higher weight on a spline in an area of the image that you do not want to move.

Resolution field Adjusts the pixel resolution of the clip being warped or morphed. A lower pixel value increases resolution. A lower pixel resolution creates warps and morphs that better follow the contours of the distortion splines, although it can slow down system performance.

Shape Stabilizer controls Gives access to the Stabilizer, for automatically tracking motion in the source clip and using this data to animate your spline.

Using Distort's Views and Clip Display

You can change the view using the Distort menu as you create your effect.

The Distort module makes it easy to toggle between Input1 and Input2 clips or mattes independently in each viewport. For example, you can display Input1 in one viewport, and the matte of Input2 in another viewport.

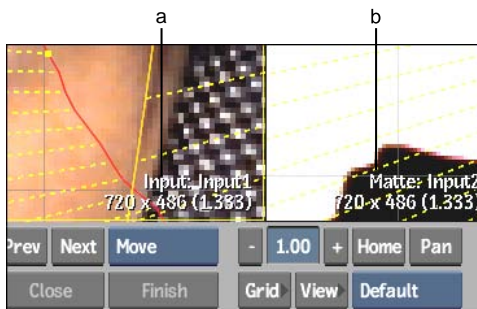

(a) Input1 clip displayed (b) Matte of Input2 displayed

Within a particular view, you can also toggle on or off clips to facilitate your work or create different effects. For example, if you loaded two inputs and their mattes, as well as a background clip, you can turn on or off any of the five clips that together make up the composite.

Changing Views

Use the appropriate view, available from the Distort menu's View box, for the task you are performing.



(a) View box (b) Input box

Select:	To view:
Input	The Input1 or Input2 clip. You toggle between them using the Input box.
Matte	Matte1 or Matte2. You toggle between them using the Input box.
Background	The background clip used in the warping or morphing effect.
Result	The result clip of the warping or morphing effect.
ResultMatte	The result matte that is created when you blend the Input1 and Input2 clips when morphing.
DistortSchm	The Distort schematic.

Each of the Input and Matte views can correlate with two views if you loaded two inputs and their mattes into the Distort module. See [Toggling Between Inputs](#) on page 1832.

While in the Input view, you can also toggle between viewing the unwarped input and the warped input by clicking between the Source and Destination buttons in the Warp and Morph menus.

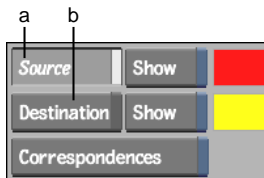

(a) Source button (b) Destination button

Toggleing Between Inputs

When you are morphing between clips, you can toggle between them so either Input1 or Input2 appears in the image window. The splines drawn on the clip are also displayed. For example, if you select Input1, the Input1 clip, along with its splines, is displayed in the image window. If you then select Input2, the Input2 clip appears with the splines drawn for Input2.

You can similarly toggle between Matte1 and Matte2.

To toggle between inputs or mattes:

- 1 From the Warp or Morph menu in the Distort module, select an option from the Input box.

Select:	To:
Input1	Display the Input1 clip if Input is selected in the View box, or Matte1 if Matte is selected in the View box, along with the Input1 source and destination splines.
Input2	Display the Input2 clip if Input is selected in the View box, or Matte2 if Matte is selected in the View box, along with the Input2 source and destination splines.

The corresponding clip with its splines is displayed. As well, the splines that are not displayed, for example, splines added to the Input1 clip if you select Input2, are indicated as hidden in Distort's schematic.

Displaying Clips

Depending on the clips you load into Distort, you can use the Clip Display buttons to produce various effects, or to simply toggle on clips and mattes to facilitate your work. The following table shows how to set up the clips to produce various effects.

Input1	Input2	Matte1	Matte2	Back	Effect
On	Off	Off	Off	Off	Warps the Input1 clip only. This is the same as loading only one input clip.
On	On	Off	Off	Off	Morphs between two clips. This is the same as loading two input clips.

In-put1	Input2	Matte1	Matte2	Back	Effect
On	Lock	Off	Off	Off	Wipes (page turns, rolls); regional warps (if the same clip is loaded as both the Input1 and Input2 clip).
On	Off	On	Off	Off	Warpes the Input1 clip and Matte1 clip, composited on black.
On	On	On	Off	Off	Warpes over a background with a matte clip.
On	Lock	On	Off	Off	Warpes the Input1 and Matte1 clips composited on the Input2 clip.
On	On	On	On	On	Morphs between two clips and their mattes onto the selected background clip.

Creating Splines

You draw open or closed splines to match the features of a clip that you want to warp or morph. Splines are drawn in a similar way as garbage masks, by clicking to add points, or by dragging to draw freehand segments.

You draw a spline around a feature at the start of an effect. When you add a spline, both a source and destination spline is added to the clip. Since these splines are initially linked together and overlap, your manipulations to the source spline affect the destination spline in the same way. After you have drawn and animated the source spline, you can unlink the splines and edit the vertices and tangents of the destination spline independently.

When creating a morph between two clips, you draw splines on the Input1 clip, then optionally copy them to the Input2 clip. When you link the splines, those copied to the Input2 clip become the destination for splines drawn on the Input1 clip.

NOTE When morphing, you can also draw source spline on the Input2 clip to link to corresponding Input1 splines. Only splines with the same number of points, and drawn in the same orientation (clockwise or counter-clockwise), will create proper morphs.

You can show or hide source and destination splines, as well as change their colours.

Drawing Splines

Draw single-point, open, or closed splines around the features you want to warp or morph at the beginning of the effect.

To draw a closed spline:

- 1 Go to the frame where you want the effect to begin.
- 2 Select Spline from the Node box.

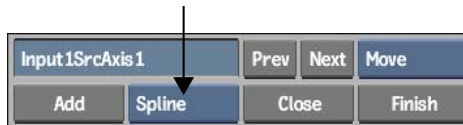

- 3 If you are creating a morph, select the input where you want to draw the spline. To add a spline to Input1, for example, select Input 1 in the Morph menu's Input box.



NOTE When creating a morph, a common strategy is to create the spline on just one input, and then copy it to the other. This has important advantages over creating splines on both inputs independently. See [Toggling Spline Nodes from One Input to Another](#) on page 1851.

- 4 Click Add (or press **N**).
- 5 Do any of the following:
 - Click to add vertices.
 - **Shift**-drag to add freehand segments to the spline. Vertices are added where you drag, and appear after you release **Shift**. You can then use the Lasso Fit parameter to increase or decrease the number of vertices that define the freehand segments of the spline. If you add or delete vertices on the spline, or exit, the influence of the Lasso Fit parameter

on the number of vertices is lost. See [Adjusting the Number of Points in Freehand Segments](#) on page 1722.

- 6 To close the spline, do one of the following:
 - Click Close.
 - Press **C**.
 - Click the first vertex.
 - While holding **Shift**, drag to the first vertex.

When the spline is closed, its vertices and tangents can then be edited.

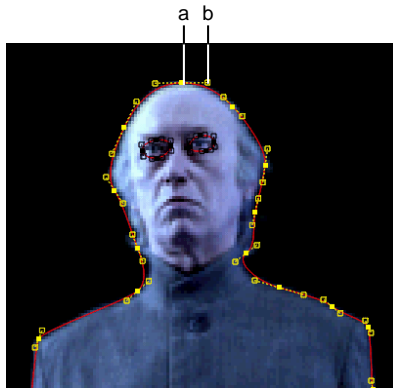

(a) Vertex (b) Tangent

Image courtesy of Behavior Communications Inc.

If you want to view the nodes that are added with each new spline, select `DistortSchm` from the View box or press the `~` key. You can use Distort's schematic to access a menu, create parent-child relationships between splines and axes, delete splines, link Input1 and Input2 splines to create morphs, as well as perform other organizational tasks. See [Using Distort's Schematic](#) on page 1841.

To draw a single-point or open spline:

- 1 Go to the frame where you want the effect to begin.
- 2 Select Spline from the Node box.

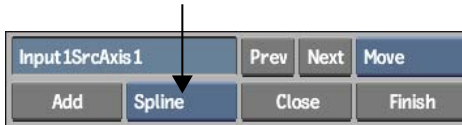

- 3 If you are creating a morph, select the input where you want to draw the spline. To add a spline to Input1, for example, select Input 1 in the Morph menu's Input box.



NOTE When creating a morph, a common strategy is to create the spline on just one input, and then copy it to the other. This has important advantages over creating splines on both inputs independently. See [Toggling Spline Nodes from One Input to Another](#) on page 1851.

- 4 Click Add (or press **N**).
- 5 Do any of the following:
 - Click to add vertices. If you are drawing a single-point spline, proceed to the next step.
 - **Shift**-drag to add freehand segments to the spline. Vertices are added where you drag, and appear after you release **Shift**. You can then use the Lasso Fit parameter to increase or decrease the number of vertices that define the freehand segments of the spline. If you add or delete vertices on the spline, or exit, the influence of the Lasso Fit parameter on the number of vertices is lost. See [Adjusting the Number of Points in Freehand Segments](#) on page 1722.
- 6 To finish the spline, do one of the following:
 - Click Finish.
 - Press **F**.
 - Click the last vertex.

When the spline is finished, its vertices and tangents can then be edited. If you want to view the nodes that are added with each new spline, select DistortSchm from the View box or press the ~ key. You can use Distort's schematic to access a menu, create parent-child relationships between

splines and axes, delete splines, link Input1 and Input2 splines to create morphs, as well as perform other organizational tasks. See [Using Distort's Schematic](#) on page 1841.

To show and hide splines:

- 1 From the Warp or Morph menu in the Distort module, do one of the following:
 - To work with source splines, click Source.
 - To work with destination splines, click Destination.
 - To work with source splines while seeing the destination splines as a reference, click Destination Show.
 - To work with destination splines while seeing the source splines as a reference, click Source Show.

NOTE To toggle between splines drawn on the Input1 and Input2 clip, select Input1 or Input2 from the Input box.

To colour splines:

- 1 Click the Source colour pot or the Destination colour pot, and use the colour picker that appears. See [Picking Colours](#) on page 71.
The colour you pick is applied to all source or destination splines accordingly.

Changing the Colour of Tangents

You can change the colour of tangents on the splines you draw. This is useful to better contrast the spline's tangents from the clip so that they are easier to work with.

To change the colour of tangents on splines:

- 1 In the Distort menu, click Setup.
- 2 In the Setup menu Display section, click the Tangents colour pot.

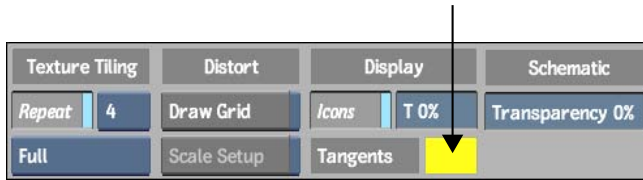

- 3 From the colour picker that appears, select a colour.
Tangents are displayed in the colour you set.

NOTE All spline tangents are initially displayed in magenta after they are drawn until a source spline and its corresponding destination spline are offset from one another.

Linking and Unlinking Splines and Axes

Warpings are created by offsetting a destination spline from its source. By default, when you draw a spline, it is linked to its corresponding source or destination. After it is drawn, you might animate it, for example, so that it follows a subject in the clip. When the splines are linked, both the source and destination splines are animated in the same way.

When you are ready to create the warp, you unlink the destination spline from its source. Manipulations then affect each spline separately, so you can alter the shape of the destination. The differences between the two corresponding splines are what creates the warp.

You can also independently unlink the axis of a source spline and the axis of a destination spline. By default, the axis nodes are linked, even if the source and destination splines themselves are unlinked. You might unlink only the axes of corresponding splines, for example, if you want their offset to create the warping effect while the actual shapes of the splines remain the same.

You use a different linking method when using source interpolation to create a morph. See [Linking Source Nodes](#) on page 1853.

To link and unlink source and destination splines or axes:

- 1 Do one of the following:
 - Select a spline by clicking it in a viewport or by clicking its spline node in the Distort schematic.

- Select an axis node in a spline node tree that is a parent to a spline node.

See [Using Distort's Schematic](#) on page 1841.

- 2 From the Warp or Morph menu in the Distort module, click the Link box to toggle between Lnk Src & Dst and Distort.



Select:	To:
Lnk Src & Dst	Link source and corresponding destination splines, or their axes. With linked splines, if you move a spline or any of its vertices both the source and corresponding destination splines are affected in the same way. With linked axes, if you move the parent axes of a spline, the parent axes of the destination spline is affected in the same way.
Distort	Allow source and destination splines or axes to be offset from one another, which creates the warping effect.

Vertices on linked splines appear in magenta. Axes that are linked appear in magenta.

NOTE If you select Lnk Src & Dst and manipulate a vertex that has already been offset from its corresponding vertex, both the source and destination vertex snap to the same position. Similarly, if you manipulate the Axis values of a spline that has been offset from its corresponding spline with Lnk Src & Dst selected, all vertices and the splines' axes snap together.

Editing Splines

You edit splines in the same way as you edit garbage masks, working with their vertices and tangents. See [Moving Vertices and Tangents](#) on page 1726.

If Lnk Src & Dst is selected from the Link box, your edits affect both the source and destination spline regardless of where you make the edits. See [Linking and Unlinking Splines and Axes](#) on page 1838.

TIP The Link box has no effect if spline nodes are linked in the Distort schematic while morphing using source interpolation. See [Linking Source Nodes](#) on page 1853.

To edit a spline:

- 1 From the Edit Mode box, select one of the following modes to edit a spline's vertices.

Select:	To:
Select	Select one or more vertices.
Move	Move vertices to a new position.
Scale	Scale vertices in relation to the axis centre of the spline.
Delete	Remove vertices from the spline.
Break	Break tangents of vertices.

Transforming Splines

You can apply transformations such as translation, rotation, scaling, and shearing to a spline. The transformation data for the spline is stored in its Axis node. See [Axis Nodes](#) on page 1844.

All transformation parameters can be animated. You can also use a motion path to animate the position of a spline. See [Creating a Motion Path](#) on page 2023.

To transform a spline:

- 1 Use the Transformation fields to modify the position, shape, and size of a spline.

	Position	Rotation	Scale	Shear	Centre	Track Axis
X	0.00	0.00	100.00	0.00	0.00	Rotation Off
Y	0.00	0.00	100.00	0.00	0.00	Scale Off
Z	0.00	0.00	100.00	0.00	0.00	Adjust On
Path			Prop			Input1

Using Distort's Schematic

The Distort schematic uses nodes to represent all the splines in the scene. The schematic shows relationships between source and destination splines, and between splines applied to the Input1 and Input2 clips.

Use the schematic to control all the splines in the scene, set parent-to-child relationships among nodes, as well as to select splines more easily.

You also use the schematic to link Input1 and Input2 source splines to create morphs using source interpolation. See [Linking Source Nodes](#) on page 1853.

When you add a spline to the Input1 clip, for example, the following spline node tree appears.

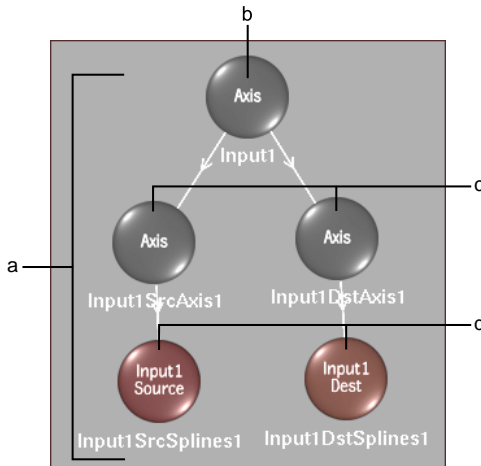

(a) Spline node tree representing corresponding splines added to Input1 (b) Axis node for an Input1 spline: the parent of corresponding source and destination splines (c) Axis nodes for each spline (d) Spline nodes for corresponding source and destination splines added to Input1

Each spline added to an input clip results in its own spline node tree in the schematic, with its own corresponding source and destination splines.

You can change an Input1 spline to an Input2 spline or an Input2 spline to an Input1 spline using the Toggle Input button. See [Toggling Spline Nodes from One Input to Another](#) on page 1851.

Visibility of the splines is controlled from the Warp or Morph menu using the Spline Display controls. When you toggle between the Input1 and Input2 clips with the Input box, splines are hidden for the inactive clip, which is also reflected in the schematic.

You can also set the transparency of the schematic. This is useful if you want to dim its display so as not to interfere with the main focus of your work.

To view Distort's schematic:

- 1 Do one of the following:
 - Select DistortSchm in the View box.



- Press the ~ key. Pressing the ~ key a second time returns to the previous view.

The Distort module's schematic appears.

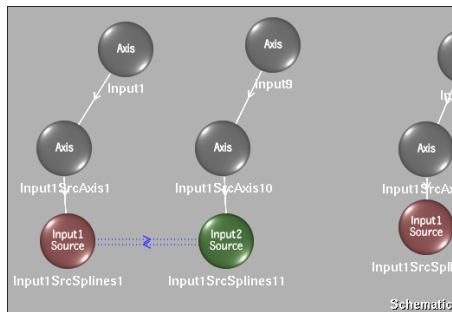

TIP Display Distort's schematic and the input clips in a multiple viewport setup. This way, you can see the splines in the clips as you select and work with them in the schematic.

To set the transparency of the Distort schematic:

- 1 In the Distort menu, click Setup.
- 2 In the Setup menu Schematic section, adjust the value in the Transparency field.



NOTE The schematic transparency has a maximum value of 90%.

Node Types

In the Distort schematic, a node can be a spline or an axis. A node exists for each spline in the scene, along with Axis nodes used to control properties of splines from the Axis menu.

You work with nodes to create parent-to-child relationships between splines, and to easily select splines. As well, nodes help you organize warps that occur between corresponding source and destination splines in a spline node tree, and morphs that occur between linked Input1 and Input2 source nodes in different spline node trees.

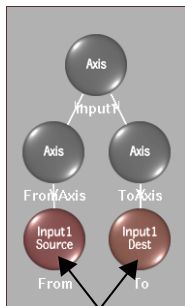

Warps occur between corresponding source and destination splines that are offset from one another

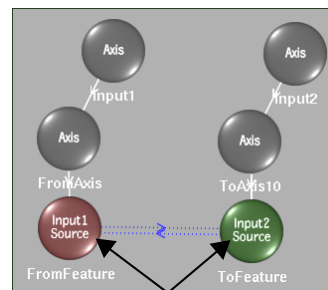

Morphs occur between corresponding Input1 and Input2 source splines that are linked together

Spline Node Trees

When you add a spline to the Input1 or Input2 clip, axis and spline nodes are added to the Distort schematic. These nodes represent the source spline and its corresponding destination spline, and are parented to axes in a spline node tree.

Warpes are created when the source spline and destination spline in a spline node tree are offset from one another.

Morphs are created when you link a source spline from an Input1 spline node tree to a source spline from an Input2 spline node tree.

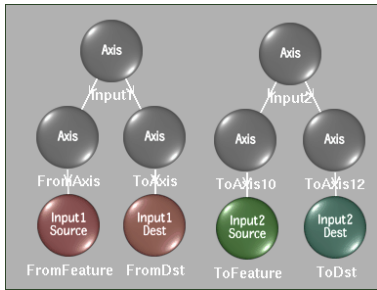

A spline node tree for a pair of corresponding splines on the Input1 clip, and a spline node tree for a pair of corresponding splines on the Input2 clip

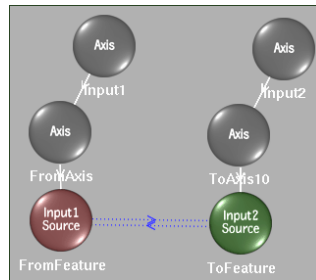

When you link source splines between Input1 and Input2 for source interpolation, the destination splines and their respective Axis nodes are removed from the spline node trees

Axis Nodes

Use Axis nodes to control the position, rotation, scale, and shear values of splines.

Initially when you add a spline, its source and destination node is parented to its own Axis node, and these Axis nodes are in turn parented to a common Axis node. So, for example, you can control the position of a particular Input1 source spline via its Axis node. Click the Axis node, the direct parent of the Spline node, then use the Axis menu in the Distort module to apply tracking data to the node.

If you want to affect both a source spline and its corresponding destination spline, you can use the Axis node at the top of the spline node tree.

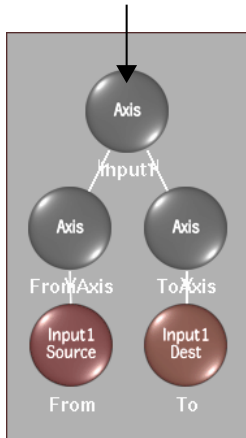

Although when you add splines, they are initially parented to their own spline node tree, you can add more Axis nodes to the schematic, and parent splines from different spline node trees to the same Axis node. This can be useful, for example, if you create splines for the different features of an actor's face and want them to move in tandem with the actor.

Axis nodes for corresponding splines can be unlinked from each other by selecting a spline's axis node, then selecting Enable Warping from the Link box.

Spline Nodes

Use the Spline node to select the spline itself, including all its points. Each spline added to the schematic results in a source and destination Spline node. Each Spline node is representative of a particular spline, which consists of a closed shape defined by vertices. If Link Src and Dst is selected from the Link Box, transformations applied to a source or destination spline also affect the corresponding spline. This does not apply when Input1 and Input2 source splines are linked for source interpolation. See [Linking Source Nodes](#) on page 1853.

When you add a spline, it is applied to the Input1 or Input2 clip, depending on what is selected in the Input box. You can then select it and change it from an Input1 to an Input2 spline, or from an Input2 to an Input1 spline. This changes the input for both the source and corresponding destination spline. See [Toggling Spline Nodes from One Input to Another](#) on page 1851.

You can add more Axis nodes to the schematic and link the spline nodes to them, for example, if you want to affect the children splines in the same way.

You can, for example, track all the points for the selected spline using the Stabilizer. You can also select the Spline node for a spline if you are having trouble distinguishing between splines in a complex setup.

TIP When using source interpolation, you can select either one of the linked spline nodes when you want to set the interpolation value between them.

Adding Nodes

When you add a spline, a spline node tree is added for Input1 or Input2. The spline node tree includes both Spline and Axis nodes.

You can add additional Axis nodes to the schematic.

To add a spline node tree:

- 1 Select Input1 or Input2 from the Input box, depending on where you want to add splines.

NOTE Splines can be changed from Input1 to Input2, or from Input2 to Input1. See [Toggling Spline Nodes from One Input to Another](#) on page 1851.

- 2 Select Spline from the Node box.
- 3 Click Add.
- 4 Draw a spline. See [Drawing Splines](#) on page 1834.

A spline node tree is added for either Input1 or Input2 in the schematic. It includes source and destination spline nodes, each parented to their own Axis node, which are in turn parented to a common axis.

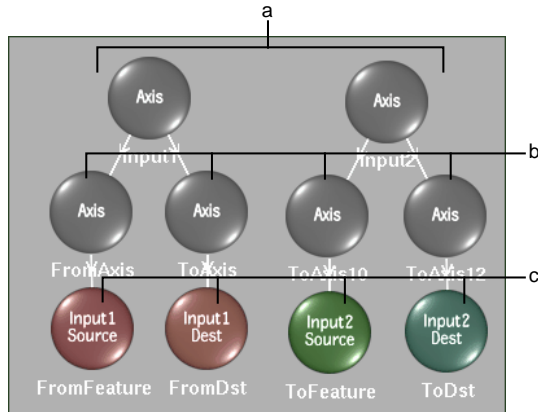

(a) Spline node trees for one Input1, and one Input2 spline (b) Axis nodes for individual spline wireframes (c) Spline nodes for corresponding source and destination splines

To add an Axis node:

- 1 Select Axis from the Node box.



- 2 Click Add.

TIP To add an Axis node between two linked nodes, hold **Shift** and drag the Axis node on top of the link. To remove an Axis node between two linked nodes, hold **Alt+Ctrl** and drag the node away from the link.

Naming Nodes

Each node that you add to the scene is automatically assigned a default name. The default name identifies the node and the order in which it was added. For example, for the first spline added to Input1, the spline nodes are called Input1SrcSpline1 and Input1DstSpline1. A second spline added to Input1 results in two more spline nodes called Input1SrcSpline2 and Input1DstSpline2.

Names appears beneath nodes in the Distort schematic and as a folder in the Channel Editor.

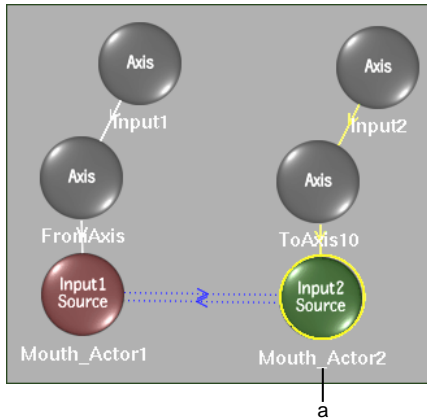

(a) Node in the Schematic

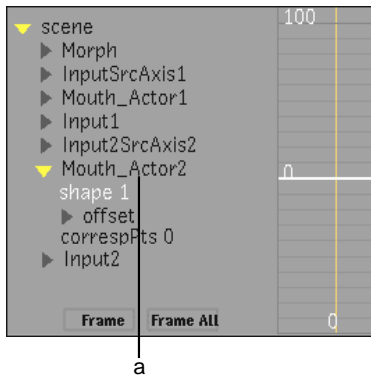

(a) Node in the Channel Editor

You can assign more meaningful names to nodes. If you rename a node, the schematic updates to show the new name. The object is also renamed in the Channel Editor.

NOTE To avoid conflicts in the Expressions editor and the schematic, you cannot duplicate names. When you duplicate an existing node name, newly created nodes have a "0" appended to their name. For example, if nodes 1, 2, 3 already exist, 3 newly created nodes would be named 01, 02, and 03.

To change the name of a node:

- 1 Select the node in the Distort schematic.
The current name for the node appears in the Name field.



- 2 Click the Name field and type the new name.

Modifying Nodes

Use the schematic controls to move, parent, unparent, link, copy, or delete nodes.



(a) Edit Mode box (b) Selection Mode box (c) Copy button (d) Delete button

Selecting Nodes

Before you can edit or animate a spline or axis in the schematic, you must select its node.

To select a node:

- 1 Do one of the following:
 - Click a node to select it.
 - Double-click a node to display its menu.
 - **Ctrl**-click to select multiple nodes.
 - **Shift**-click to add a node to an existing selection.
 - Use the Prev and Next buttons to select the next or previous node depending on the current selection.

Moving Nodes

Use Move mode to move nodes in the schematic. Moving the nodes in the Distort schematic has no effect on the relationships between nodes, nor does it affect the position of the splines in the scene.

To move a node in the schematic:

- 1 From the Edit Mode box, select Move.
- 2 Click the node you want to move and drag it to a new position. To select several nodes, **Ctrl**-click.
To move a node and its children, press and hold the **Alt** key while dragging the parent. For example, you can drag a spline node tree by **Alt**-dragging its top Axis node.

Deleting Nodes

You can remove nodes from the schematic using the Edit Mode box or the Delete button.

To delete a node using the Edit Mode box:

- 1 From the Edit Mode box, select Delete.
- 2 Click the node you want to delete.
The node is removed from the scene.

To delete objects using the Delete button:

- 1 From the Selection Mode box, select an option.

Select:	To:
Selected	Delete the currently selected node. For example, this option deletes a spline node without deleting its parent axis, or an axis without deleting its spline node.
Branch	Delete the selected node and all its children.
All Nodes	Delete all nodes in the scene.

- 2 Click Delete.

Parenting Nodes

Use Move mode from the Edit Mode box to change the parent-to-child relationship between nodes in the Distort schematic. By using Move mode, and dragging from one node to another, a node becomes the parent of another node. You can also use Move mode to remove parent-to-child relationships between nodes by dragging across the line linking them in the schematic.

Use Move mode when you create branches. See [Creating Branches](#) on page 2110.

Toggling Spline Nodes from One Input to Another

Morphs work best when the source spline and destination spline have the same orientation—that is, were both drawn clockwise or counterclockwise—and the same number of vertices. You can ensure this is the case by drawing your spline on one input, then copying it to the other. To do this, first copy the spline, and then “move” the copy using the Morph menu's Toggle Input button. It toggles the selected spline from one input to the other.

TIP To create a copy of a spline, see [Copying Nodes](#) on page 1853.

To toggle a Spline node's input:

- 1 Select the source or corresponding destination Spline node you want to change from Input1 to Input2, or from Input2 to Input1.

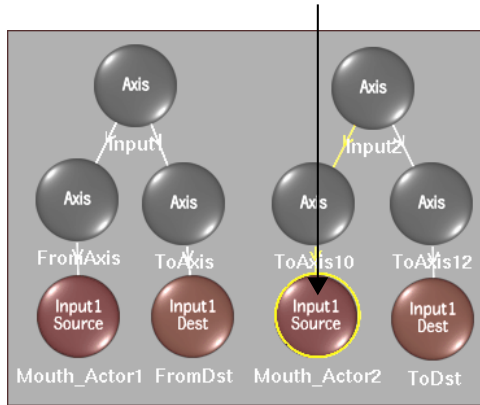

NOTE You can also select the spline directly in the clip.

- 2 Click Toggle Input.



The source and destination spline nodes change either from Input1 to Input2, or from Input2 to Input1.

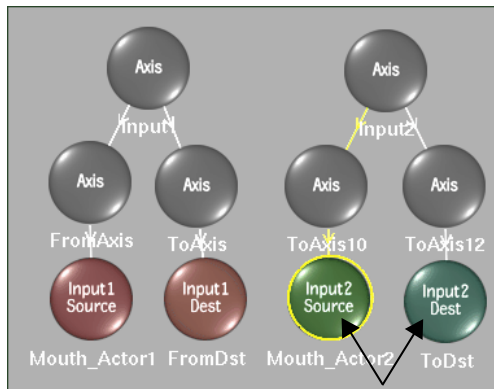

Linking Source Nodes

You link a spline source node from Input1 to a spline source node from Input2 to create interpolation between them for a morph. Destination splines are no longer used and cleared from the schematic. The source of the Input2 spline node tree becomes the destination of the Input1 spline node tree.

You can create as many relationships between Input1 and Input2 spline nodes by linking them in the schematic, as there are features to correlate between the clips.

To link source nodes:

- 1 Select Link from the Edit Mode box (or press L).
- 2 Drag from an Input1 source spline node to an Input2 source spline node.

NOTE You can only link a source spline from an Input1 to a source spline from Input2.

The splines are linked to each other, as indicated by the blue dotted connector lines. The destination splines, and their respective Axis nodes, are removed from the two spline node trees. Once Spline nodes are linked, you can set an interpolation value to determine the percentage that the feature defined by the Input1 spline mixes with the feature defined by the Input2 spline. See [Interpolating Features](#) on page 1859.

To unlink nodes:

- 1 Select Link from the Edit Mode box (or press L).
- 2 Drag the cursor across the line that joins the two linked source spline nodes.

The spline nodes are unlinked, and the destination splines and their axes reappear for each of the affected spline node trees.

Copying Nodes

Use the Copy button to copy an object, a branch (object and its children), or all.

To copy a single object or branch:

- 1 In the Distort schematic, select the object you want to copy.

2 From the Selection box, select an option.

Select:	To:
Selected	Copy the currently selected object.
Branch	Copy the selected object and all its children. To avoid copying objects by mistake, use the Schematic view to determine which objects you are copying.
All Nodes	Copy all objects in the scene.

3 Click Copy.

TIP When morphing, you can copy splines and then toggle their input, which results in corresponding splines on the Input1 and Input2 clips that can then be linked for source interpolation. See [Toggling Spline Nodes from One Input to Another](#) on page 1851.

Animating and Tracking Splines

If the image you are warping or morphing is in motion, it will be necessary to animate each spline so it moves with the feature of interest. To animate a spline, set keyframes for its axes or vertices at various places in the clip. The motion between the keyframes is automatically interpolated. Alternately, use the Stabilizer to automate the process by tracking a reference point and connecting an axis or vertex to the resulting tracking data. Whichever method you choose, you can further control the shape of the spline by adding or removing vertices throughout the animation.

NOTE You can also animate correspondence points to refine the mapping of the source spline to its destination over time. See [Working with Correspondence Points](#) on page 1860.

For example, if you are creating a warp, you can load the Input1 clip into the Stabilizer and track all of the source spline's vertices. With Enable Warping selected from the Link box, you can then manually edit the points of the destination splines along the course of the clip to create the desired warp.

Similarly, if you are creating a morph, you can track the vertices of both source splines on the Input1 clip, as well as the source splines on the Input2 clip. When you then link the splines together in the Distort schematic for source

interpolation, the morph animation is already set. You can refine the morph by further animating the destination spline.

At any frame, you can control the shape of the spline by adding and removing vertices. If the feature you are tracking gets larger, for example, you can add vertices to adjust the shape of the spline. Similarly, you can remove vertices that are no longer needed. Make them inactive from one keyframe to the next using the Active button, or permanently delete them. See [Manipulating Vertices and Tangents](#) on page 1725.

Animating Splines

Set keyframes for spline vertices and tangents over the course of the clip.

To animate a spline:

- 1 Move to the frame where you want to begin animating the spline.
- 2 If necessary, do one of the following to display the spline you want to animate:
 - From the Warp or Morph menu, click Source to display source splines, or click Destination to display destination splines. You can also use the Show buttons to display both source and destination splines.
 - If you are working with two clips, with either Input, Matte, or Result selected in the View box, toggle the Input box to Input1 or Input2, depending on which spline you want to animate.
- 3 Select the spline in the clip or its node in the Distort schematic.
- 4 Enable Auto Key in the Animation menu.
- 5 Select Move mode in the Edit box, then select and move one or more vertices to a new location. You can also move vertex tangents.
- 6 Advance the positioner to a different frame then move some more vertices.
- 7 Continue to move vertices and tangents as you progress through the clip, so the spline follows the movement of the feature you are warping or morphing.

Loading a Clip into the Stabilizer

Use the Stabilizer controls in the Warp menu or in the Morph menu to select the clip you want to track, the spline you want to apply the tracking data to, and the tracking mode (Axis or Shape). See [Stabilizing](#) on page 1793.

Select from the Track Clip box: To track:

Input1	The Input1 clip.
Input2	The Input2 clip.
Matte1	The Matte1 clip.
Matte2	The Matte2 clip.
Background	The background clip.

Tracking by Axis

To make the spline follow the movement in the clip without changing shape, apply the tracking data to the spline's axis.

To track by axis:

- 1 Set the Stabilizer controls to apply the tracking data to either the source (Src) or destination (Dst) spline for either the Input1 or Input2 clip. Select the Axis node in the Distort schematic that is the parent of the spline you want to track.
- 2 Select the clip you want to track from the Track Clip box.

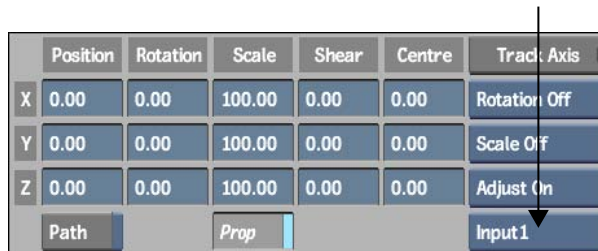

- 3 Click Track Axis.
The Stabilizer menu appears.
- 4 Position the tracker on the image. Tracker 1 controls the position. Tracker 2 controls the rotation or scale. See [Working with Trackers](#) on page 1785.

- 5 To use two trackers, click Tracker 2, click Active, and position the second tracker on the image.
- 6 Click Analyse to generate the tracking data.
- 7 If necessary, fine-tune the analysis.
- 8 When you are satisfied with the tracking results, click Return to apply the results to the axis and return to Distort.

Tracking by Vertices

To make the spline follow the movement and shape change in the clip, apply the tracking data to the spline's vertices.

To track by vertices:

- 1 Select the spline's vertices that you want to affect. You can first select a spline by clicking its Spline node in the Distort schematic.

TIP Double-clicking a Spline node displays the Warp or Morph menu.

- 2 Set the Stabilizer controls to apply the tracking data to either the source (Src) or destination (Dst) spline for either the Input1 or Input2 clip.
- 3 Click Track Shape.



The Stabilizer menu appears. A tracker appears on each vertex that you selected. The reference frame is the frame from which you opened the Stabilizer.

- 4 If necessary, adjust the position of the trackers to ensure that each tracker has a good reference point.
- 5 Click Analyse to generate the tracking data, and if necessary, fine-tune the analysis.

For example, disable a problem tracker and re-analyse, as described in [Tracking Difficult Shots and Correcting Errors](#) on page 1805.

- 6 When you are satisfied with the tracking results, click Return to apply the results and return to Distort.

Copying and Pasting Tracking Data

You can copy and paste tracking data from one mesh to another using the Channel Editor. For example, if tracking was done using Axis, you can copy the translation of the Input1 source spline and apply it to the Input2 source spline.

Example: To copy translation data:

- 1 Click Animation to display the Channel Editor.
- 2 Select the X and Y channels in the Input1_src translate folder.
- 3 Click Copy.
- 4 Select the X and Y channels in the Input1_dst translate folder.
- 5 Click Paste.

The translation channels containing the tracking data from the Input1 source spline are pasted into the Input1 destination spline.

Blending Clips

When you morph features from an Input1 clip to features from an Input2 clip or a background clip, you add a blend to the Input1. By blending the clip over time, the Input1 dissolves into the Input2 or the background. Matching features, for example, the mouth of an actor on the Input1 clip, and the mouth of an actor on the Input2 clip, as defined by the corresponding source and destination splines, can correspondingly blend from one to the other as the second clip becomes visible.

To blend the Input1 clip into the Input2 clip or background:

- 1 From the Morph menu, adjust the value in the Blend box. A value of zero results in the Input1 clip being totally opaque, while a value of 100 results in the clip being completely transparent.

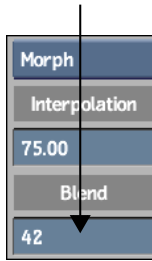

TIP The blend value you set can be animated over time, and is displayed in the Channel Editor by a transparency channel in the Morph folder.

Interpolating Features

Set interpolation values for each set of Spline nodes you linked in the Distort schematic.

The interpolation value determines the percentage that the feature defined in the Input1 source spline mixes with the feature defined in the Input2 source spline.

To set the interpolation value between linked splines:

- 1 Select the Input1 or Input2 source Spline node of a linked pair in the Distort schematic.

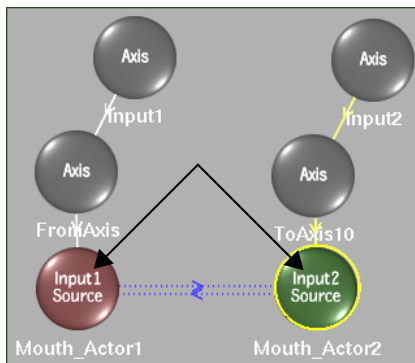

The current interpolation value for the linked splines appears in the Interpolation field.

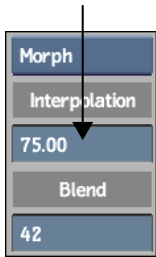

- 2 Set the value for the interpolation. A value of 0 results in the Input1 feature remaining in its original form, while a value of 100 results in the Input1 feature distorting into the shape defined by the Input2 spline.

Refining Distortions

There are numerous methods and techniques to refine your distortions. You can adjust the correspondence between source and destination splines using correspondence points if a feature from Input1 is not mapped correctly to the corresponding Input2 feature. You can work with the number of iterations to increase the warping effect, or limit the affected region of the clip. As well, you can adjust clip resolution to affect how well clips distort.

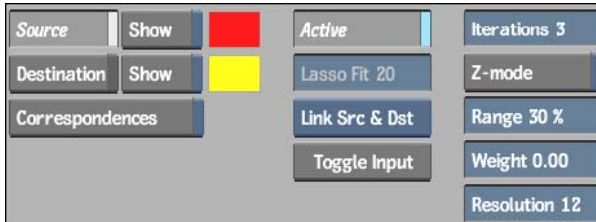

Working with Correspondence Points

Correspondence points indicate how one frame is mapped to another in relation to source and destination splines, or Input1 and Input2 source splines when using source interpolation. If part of a clip is pulled or shifted too much during a distort, you can realign it by adjusting the correspondence points.

By default, correspondence points are added automatically. You can display the points, move them around the splines, animate them, as well as add and delete points to create a correspondence that better suits your needs. The more

correspondence points a spline has, the more control you have over how the warp or morph is mapped.

To show correspondences:

- 1 Toggle on the visibility of the source splines and destination splines using the Show buttons.
 - 2 In the Distort module, click Correspondences.
- Correspondence points are shown on the source and destination splines, and are connected by dotted lines. Selected splines show the connections with yellow dotted lines; unselected splines shown them in grey.

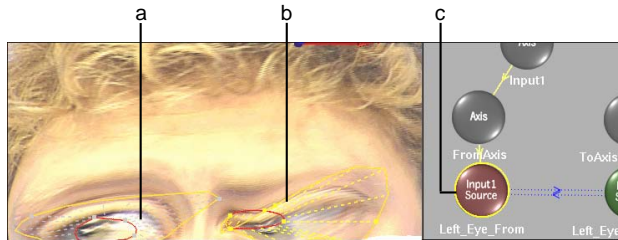

(a) Correspondences of unselected spline (grey) (b) Correspondences of selected spline (yellow) (c) Selected spline in Distort schematic

To move correspondence points:

- 1 Click Correspondences to display the correspondence points.
- 2 Select Move mode from the Edit box, then click and move a point on either the source or destination spline.
You can also select multiple points by **Shift**-clicking them.
Points can only be moved between the two points that surround it on the spline.

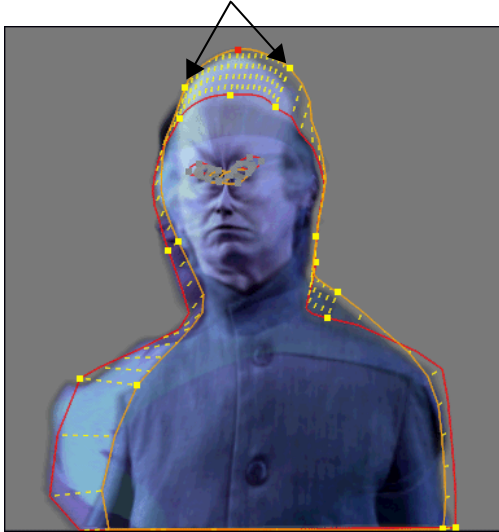

The correspondence point can only be moved between the two surrounding points

Image courtesy of Behavior Communications Inc.

The warped or morphed region is remapped according to the changes made to the correspondence points.

To add correspondence points:

- 1 Click Correspondences to display the correspondence points.
- 2 Select Add from the Edit Mode box.
- 3 In the region of the clip where you want to improve the mapping, click the source or destination spline to add a new correspondence point.
A point is added. As well, a corresponding point is added to the corresponding spline. You can then move either of these points to improve the mapping of the clip. The more correspondence points there are, the more refined the distortion.

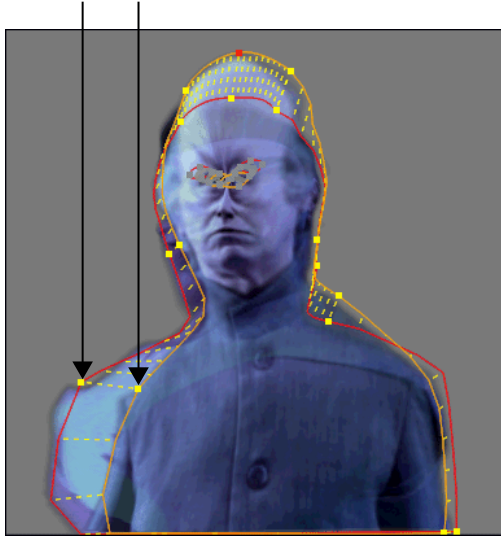

Adding a correspondence point to a source spline adds one to the destination spline

Image courtesy of Behavior Communications Inc.

To animate correspondence points:

- 1** Move to the frame where you want to begin animating correspondence points.
- 2** Display a source and destination spline by clicking the Source Show and Destination Show buttons.
- 3** Click Correspondences to display correspondence points.

TIP The source and destination splines should be offset from one another to best be able to animate their correspondence points.

- 4** Enable Auto Key in the Distort menu.
- 5** Select Move mode in the Edit box, and then move one, or more, correspondence points to a new location.
- 6** Advance the positioner to a different frame and then move a correspondence point again.

- 7 Continue to move correspondence points as you progress through the clip to refine the warp or morph over time.
Correspondence point animation for each spline is kept in a corresPts channel in the Channel Editor. See [Distort Animation Channels](#) on page 1868.

To delete correspondence points:

- 1 Click Correspondences to display the correspondence points.
- 2 Select Delete from the Edit Mode box.
- 3 Click a correspondence point on the source or destination spline.
The point you clicked and the corresponding point on the corresponding spline are deleted.

Adjusting Resolution

Resolution affects the sampling of the clips loaded into the Distort module. The resolution value represents the number of pixel squares that the image is sampled at. Decrease the resolution value if you find your clips are not deforming smoothly.

NOTE Decreasing the resolution value slows down system performance.

To adjust resolution:

- 1 Use the Resolution field to increase or decrease resolution. A smaller value increases the number of samples, producing a higher quality distortion.

Adjusting the Degree of Distortion

The Distort module includes parameters that allow you to easily control the degree of distortion in a warp or morph. You can adjust the Iterations parameter so the distorted source pixels more closely approach the destination spline. Similarly, you can adjust the Range parameter to affect all the pixels in the image, or just those in the immediate region of the warp. Displaying the distortion grid can help you evaluate the effects of your changes.

To create a warp or morph, invisible iteration points are added between the source and destination splines. These iteration points determine how many

time the pixels between the splines is examined when the calculations are performed. Adjusting the number of iteration points is relevant when the distance between the splines is great; that is, when you are trying to achieve a large warp. With a small iteration number, the warp will not “follow” the destination spline closely. Increasing the number of iterations will result in a more obvious distortion. For smaller warps or morphs, there is no advantage in using a greater number of iterations; it simply increases processing time unnecessarily.



With a low number of iterations, a distortion can sometimes be too subtle

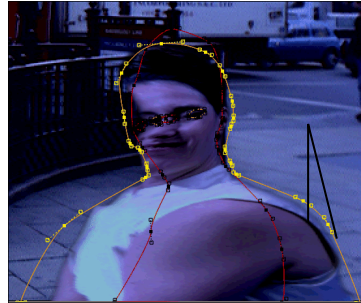

Increasing the number of iterations results in a more obvious distortion

Images courtesy of Behavior Communications Inc.

By adjusting the range, you can control the region affected by the distortion. A lower value decreases the region affected by the warp, while a higher one increases it. For example, a value of 100% affects all the pixels in the image, a value of 33% affects one-third of the image, a value of 25% affects one-quarter of it. To restrict the distortion to the area immediately surrounding the vertex, choose a higher region number. To broaden the effect, choose a lower number. This parameter has a smaller effect on processing time than the number of iteration points.

To display the distortion grid:

- 1 In Distort's Setup menu, enable Draw Grid.

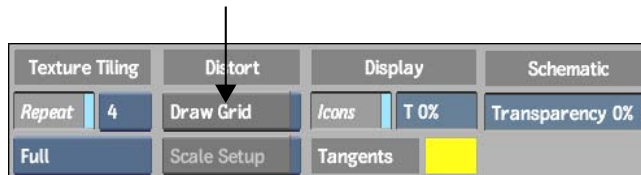

To adjust the amount the distortion “follows” the destination spline:

- 1 In the Warp or Morph menu, change the value in the Iterations field.

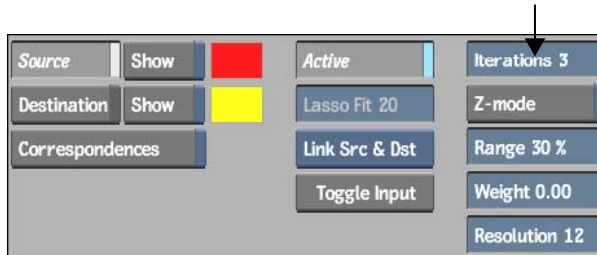

To change the size of the region affected:

- 1 In the Warp or Morph menu, change the value in the Range field.

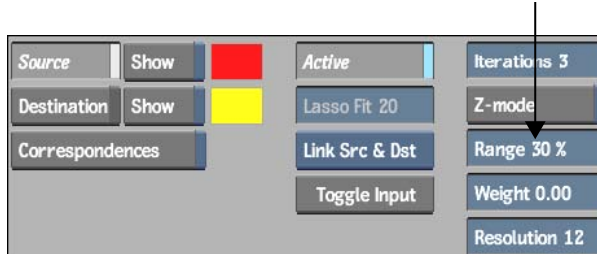

Filling in Gaps at Edges of Distorted Clips

As you warp surfaces, sometimes their edges are pulled away from the absolute edge of the image, revealing either the background clip, or blank space.

You can fill this revealed area with the warped clip by repeating it.

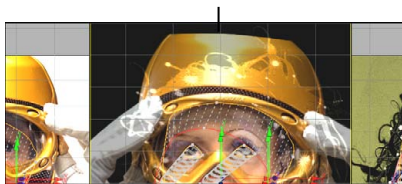

Without Fill

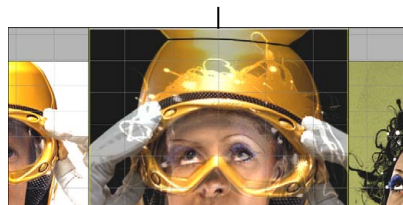

With Fill, set to Part

Images courtesy of Das Werk and The House

To fill in gaps at edges of a distorted clip:

- 1 Click Setup.

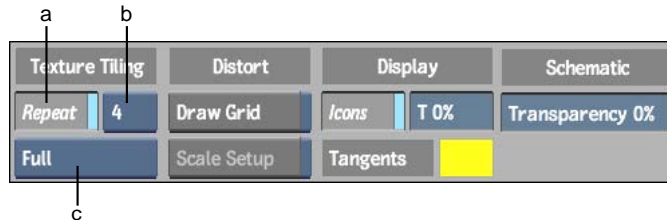

(a) Repeat button (b) Repeat value (c) Amount box

- 2 In the Texture Tiling section, Enable Repeat.
- 3 Toggle the Repeat value to set the number of times the clip is repeated to fill the gaps:
 - Select 4 to repeat the clip once on each side: top, bottom, left, and right.
 - Select 8 to repeat the clip twice on each side.
- 4 Toggle the Amount button to control the portion of the clip to use to fill the gaps:
 - Select Full to squeeze the whole clip into each of the gaps.
 - Select Partial to use only a mirrored corresponding, and proportional portion of the clip to fill each of the gaps.

Warping Example

You can create many warps on a single input clip. Each destination spline offset from its source creates a warp on the clip. The following is an example of a simple warp.

To create a warp:

- 1 Once a spline shape has been made, click Warp to display the Warp menu.

- 2 From the View box, display the Result view to see the spline shape over the input clip.
- 3 Set the timebar positioner to the effect's first frame.
- 4 From the Warp menu, enable Source.
All Input1 source splines are displayed.
- 5 If necessary, adjust the vertices of the shape by moving points or curve handles.

TIP To prevent the warping of the clip as you edit a spline, make sure Link Src & Dst is selected in the Link box. Otherwise, as you edit either a source or destination spline, it will be offset from its corresponding source or destination—this is what will eventually create your warp. You can toggle between Link Src & Dst and Enable Warp by pressing the **W** hot key.

- 6 Set the timebar positioner to the effect's final frame.
- 7 From the Link box, select Distort.



- 8 Enable Destination, and then adjust the vertices of the shape by moving points or curve handles. Edits to the destination spline-based shape will produce immediate warping.
- 9 Refine the warp as necessary. See [Refining Distortions](#) on page 1860.

Distort Animation Channels

The Distort module includes channels for the Blend value as well as for all the Axis nodes in the schematic. Each spline in the effect contains a shape channel, with its vertex information, and an offset channel. As well, each spline contains a correspondence points channel containing point location information. All these channels are in the Morph folder in the Channel Editor.

When splines are linked, two additional channels appear under the Input1 spline's folder in the Channel Editor: an Interpolation channel corresponding to the value in the Interpolation field for the pair of linked spline nodes, and an interpShape channel. The interpShape channel contains the vertex information for the interpolated spline, which is the destination of the morph.

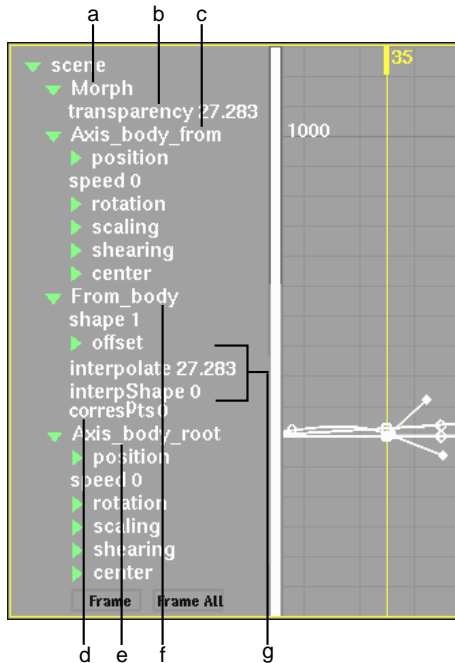

- (a) Morph folder contains all folders and channels for both warps and morphs
- (b) Transparency channel corresponds to Blend parameter in Morph menu
- (c) Axis node folder for parent of Spline node
- (d) Correspondence points channel contains correspondence point information for the spline
- (e) Axis node folder for root of source and corresponding destination spline
- (f) Spline node folder for spline shape
- (g) Interpolation channels appear when spline nodes are linked in the schematic, under the Input1 spline node's folder

Interpolation and InterpShape Channels

You can adjust the Interpolation and interpShape channels in the Channel Editor for each set of linked Input1 and Input2 splines to refine a morphing effect.

Each pair of linked Spline nodes produces an interpolated spline, which in turn, can be edited and animated independently.

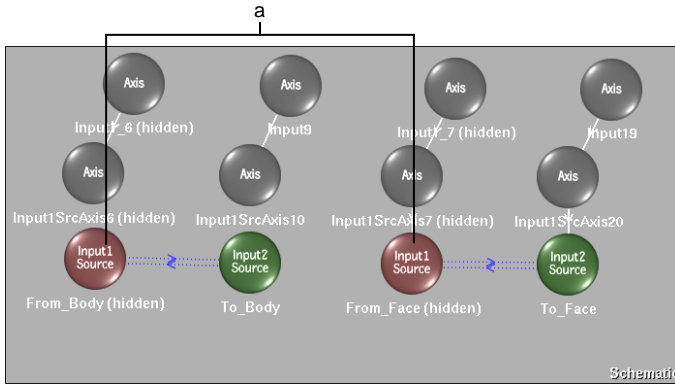

(a) Interpolation and interpShape channels appear for linked spline nodes

The two interpolation channels, corresponding to linked spline nodes, are always in the Input1 source Spline node's folder in the Channel Editor.

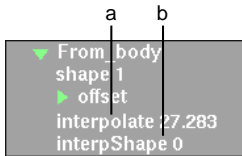

(a) Corresponds to value in Interpolation field of Warp or Morph menu (b) Contains vertex information for interpolated spline

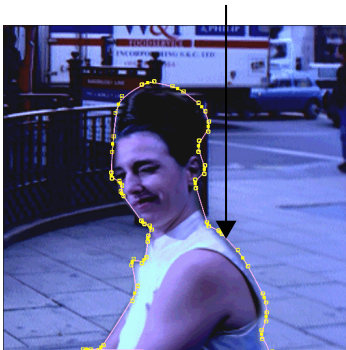

With Result selected in the View box, Input1 selected in the Input box, and Source enabled, the source spline on Input1 is displayed. It has a shape channel containing its vertex positions over time.

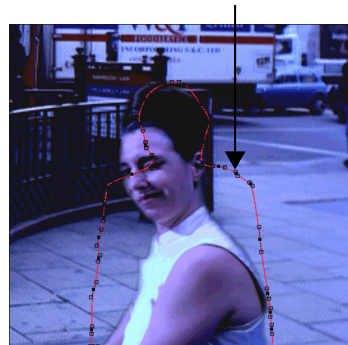

With Result selected in the View box, Input2 selected in the Input box, and Source enabled, the source spline on Input2 is displayed. It also has its own shape channel containing its vertex positions over time.

Images courtesy of Behavior Communications Inc.

When an Input1 and Input2 spline are linked in the schematic, you select Result in the View box, Input2 in the Input box, and Destination to view the interpolated spline. The interpolated spline is the result of mixing the Input1 and Input2 source splines. Since it is the target of the morphing effect, you must click Destination to display it.

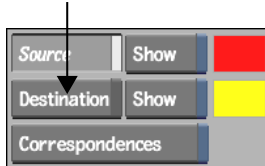

The interpolated spline's vertex information is contained in the interpShape channel in the corresponding Input1 spline's folder. Although the spline is a result of mixing the Input1 and Input2 source splines according to the Interpolation value, it can be controlled and animated independently.

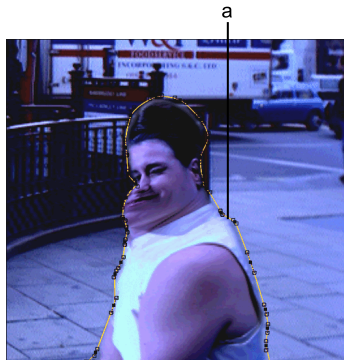

(a) Morph follows contour of interpolated spline

Image courtesy of Behavior Communications Inc.

TIP Since each Interpolation channel, for every pair of linked Input1 and Input2 source splines, is independent, try using the Channel Editor's Link button on multiple Interpolation channels. This allows a common interpolation value for many sets of linked splines.

Using Distort in Batch

Use other nodes in combination with the Distort node in Batch to create more seamless warps and morphs that can be composited into media in Action.

Creating a Distortion to Feed into Action Media

You can create a morph effect in Distort, then feed the result, and the ResultMatte, into media in an Action node, to composite with additional media.

To create a distortion feeding into Action media:

- 1 In Batch, add an Input1 clip and its corresponding matte, and an Input2 clip and its corresponding matte.
- 2 Add a background clip.

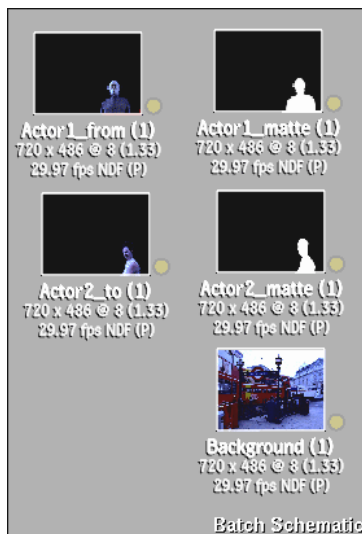

Images courtesy of Behavior Communications Inc.

NOTE The background clip will feed into the Action node, not the background socket of the Distort node.

- 3 Add a Distort node.

- 4 Add a Colour Corrector node.
- 5 Add an Action node.
- 6 Connect the Input1 clip to the Colour Corrector node.
- 7 Connect the Colour Corrector node to the Input1 socket of the Distort node.
- 8 Connect the other clips to their corresponding sockets on the Distort node: Input2, Matte1, and Matte2. There is no background connected to the background socket since Distort will feed into media of the Action node.

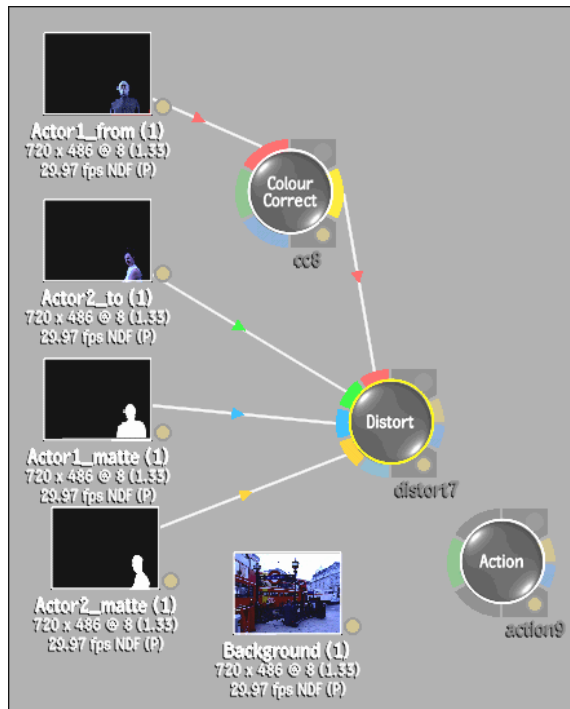

Images courtesy of Behavior Communications Inc.

- 9 Double-click the Distort node to load its controls into the work area.
- 10 Create the morph between the Input1 and Input2 clips.
- 11 Split the screen and create a context view for the Distort result and display it in a viewport.

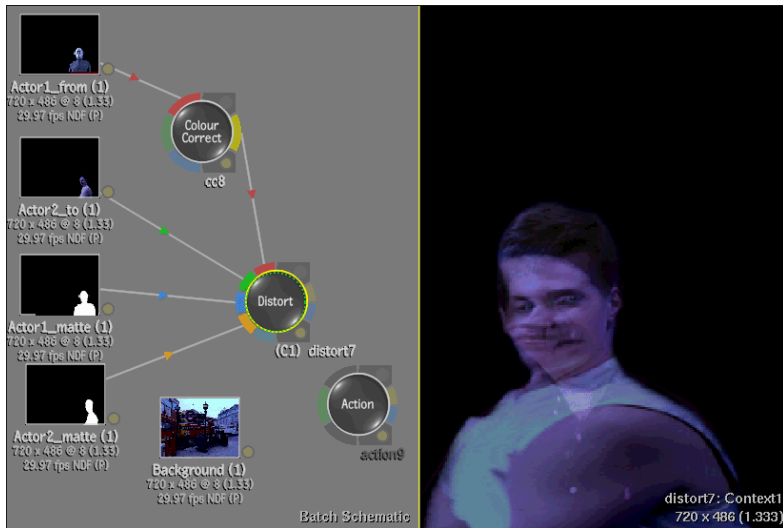

Images courtesy of Behavior Communications Inc.

- 12 In the other viewport, access the result of the Colour Corrector. Create an animated colour correction for the Input1 clip to gradually transition to the colours in the Input2 clip.
- 13 In the Action node, connect a background clip to it.
- 14 Within the Action node, **Ctrl-click Add** to add media that feeds into the Action node in the Batch schematic.
- 15 Feed the Result and the ResultMatte of Distort into the front and matte of the media, in turn feeding into Action.

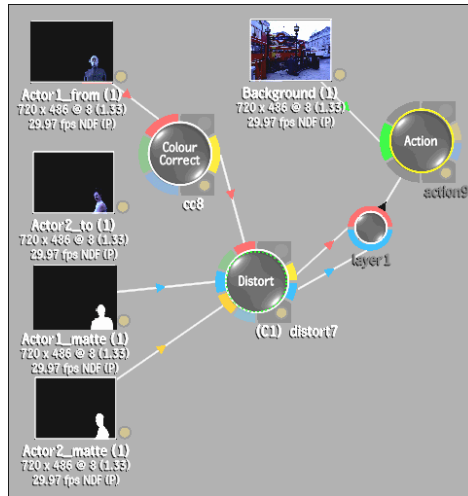

Images courtesy of Behavior Communications Inc.

- 16 In Action, add a surface for the media.
- 17 Animate the media.

Saving Preferences

You can save preferences for the Distort module.

The state of the following parameters are saved as preferences:

- Autokey
- Icons
- Icon Transparency
- Fill
- Source/Destination
- Show Destination
- Axis Motion Path
- Axis Scale Proportional

You can save preferences as a file you can reload, or as the module's defaults which are loaded when you reset all, or create new Distort nodes in Batch.

For more information on saving and loading preferences, and managing default preferences, see [Saving, Loading, and Deleting Items](#) on page 802 and [Setting the Default Preferences](#) on page 805.

Saving and Loading Distort Setups

Distort setups can be saved and loaded as setup files, with spline and other information preserved. You can also exchange Distort setups between the desktop and the Distort node in Batch.

To save a Distort setup:

- 1 In the Distort menu, click Save to open the file browser. From the Distort node in Batch, click Setup and then Node to display Distort's Setup menu.
- 2 Select Setup as the type of file to save.
- 3 Type the name of the setup, and click Save.

To load a Distort setup:

- 1 In the Distort menu, click Load to open the file browser. From the Distort node in Batch, click Setup and then Node to display Distort's Setup menu.
- 2 From the file browser, select the name of the setup to load.

NOTE If the Distort setup you are loading was created in a different resolution than the current project, click Scale Setup to scale the setup's splines.

Topics in this chapter:

- [About the Warper](#) on page 1877
- [Accessing the Warper](#) on page 1878
- [Setting Up the Clips](#) on page 1879
- [Creating Meshes](#) on page 1880
- [Modifying a Mesh](#) on page 1883
- [Modifying the Meshes for Live-Action Clips](#) on page 1891
- [Warping](#) on page 1896
- [Morphing](#) on page 1899
- [Setup Options](#) on page 1905

About the Warper

In the Warper, you can warp a clip or morph from a source clip to a result clip. Warping is free-form distortion of an image, such as elongating someone's nose. Morphing is a transition effect that matches the morphology of one clip gradually to that of another clip, such as a human morphing into an alien.

Accessing the Warper

You must select the required clips to access the Warper. You can enter the Warper with one to five clips. The number of clips that you load depends on the effect that you want to produce.

To access the Warper:

- 1 In the Main menu, click Effects, and then click Warper.
- 2 Select the types of clips you want to load into the Warper from the Input Mode box.

Select:	To load:	To produce:
Front	Front clip only	A warp of a single image.
Front Back	Front and back clips	A morph, a wipe, or a regional warp.
Front Matte	Front and matte clips	A warp of a single image using a matte.
Front Back Matte	Front, back, and matte clips	A warp over a background using a matte.
Front Back Matte Back/M Bkg	Front, matte, back, back matte, and background clips	A morph using two clips and their mattes on a background clip instead of on black.

- 3 Select the source clip(s).
- 4 Select the destination reel.
The Warper menu appears.

NOTE Regardless of which clips you load into the Warper, there are always two compositing layers available: a front layer and a back layer. If you do not load a back clip, black is used for the back layer.

The Warper menu includes the following controls.

Setup button Sets playback options, changes display colours, and inputs slip values.

Warp button Displays the Warping controls.

Morph button Displays the Morphing controls.

Animation button Displays the animation channels and the animation curves.

To reset the Warper:

- 1 Click Reset All, and click Confirm when prompted.
Warper options are restored to their default settings.

Setting Up the Clips

Use the Clip Setup boxes to specify how each clip loaded into the Warper will be used.

Front	On
Back	Off
Matte	Off
Back Matte	Off
Background	Off

For Front and Back clips, the Clip Setup box contains On, Off, and Lock options. For Matte and Back Matte clips, the Clip Setup box contains On, Off, and Invert options. Background clips contain On and Off options.

Select:	To:
On	Warp the clip.
Off	Disable the clip. When a clip is disabled, it is not displayed and is not used in the processed result.
Lock	For Front and Back only, process the front or back clip in the final composite without warping it.
Invert	For Matte and Back Matte only, invert the front or back matte.

Activating Clips

The following table shows how to set up the clips to produce various effects.

Front	Back	Matte	Back Matte	Back ground	Effect
On	Off	Off	Off	Off	Warp the front clip only. This is the same as loading a front clip only.
On	On	Off	Off	Off	Morphs between two clips. This is the same as loading a front clip and a back clip.
On	Lock	Off	Off	Off	Wipes (page turns, rolls); regional warps (if the same clip is loaded as the front clip and the back clip).
On	Off	On	Off	Off	Warp the front clip and matte clip, composited on black.
On	On	On	Off	Off	Warp over a background with a matte clip.
On	Lock	On	Off	Off	Warp the front and matte clips composited on the back clip.
On	On	On	On	On	Morphs between two clips and their mattes onto the selected background clip.

Creating Meshes

After you load and set up your clips in the Warper, you create meshes to define the shape and position of the input image—the original image before the warp or morph—and the output image—the result of the warp or morph. The meshes use control points to determine the change, in shape and position, and create a convincing transition from the input image to the output image.

You use two meshes, a source mesh and a destination mesh, to generate the warp effect. For instance, if you want to morph a square into a circle, the source mesh defines the input image, which is a square, and the destination mesh defines the output image, which is a circle.

Defining a Mesh

When creating a mesh, you anchor the mesh to the surrounding area. To ensure this, create the mesh over a slightly larger area of the image than the part you want to affect. For example, to warp a person's mouth, extend the mesh to cover the lower half of the person's face. This “anchors” the area surrounding the warp so that it is not affected by the warp. You begin by defining the number of patches in the mesh and then placing it over the required area in the image.

To define a mesh:

- 1 Go to the frame where you want the effect to begin.
- 2 Specify which mesh will be created.

Meshes		Mapped To
<i>Front Source</i>	Show	Front Source
Front Destination	Show	Source Interp
Back Source	Show	Back Source
Back Destination	Show	Source Interp
Source Interp	Show	

Click:

To create:

Front Source

The front source mesh.

Front Destination

The front destination mesh.

Back Source

The back source mesh in a morph.

Back Destination

The back destination mesh in a morph.

For information on when to create each type of mesh, see [Warping](#) on page 1896 and [Morphing](#) on page 1899.

- 3 Click Add Mesh.

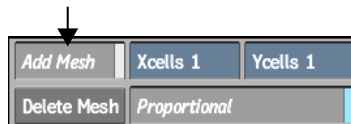

- 4 In the Xcells and Ycells fields, set the number of patches for the mesh. For example, to create a mesh that is 10 patches wide by 5 patches high, enter 10 in the Xcells field and 5 in the Ycells field.
Enable the Proportional button to automatically set the X and Y cells fields to the same value.
- 5 Click the image and drag the cursor to draw the mesh.

TIP If you cannot see the mesh properly against the colours in the image, you can customize the colours of the various meshes using the colour pots beside each mesh name.

Adding Patches

As you build the mesh, you may need to add patches to cover more of the image.

To add patches:

- 1 In the Warper menu, click Add Mesh.
- 2 To add only one patch, click the edge of the patch that is closest to where you want to add a patch.
The new patch is approximately the size of the adjacent patch.
- 3 To add several patches, drag from the edge of an existing patch over the area in which to add patches.
Each new patch added is approximately the size of its adjacent patch.

Deleting Patches

You can delete patches if you make a mistake while creating the mesh.

To delete patches:

- 1 In the Warper menu, click Delete.

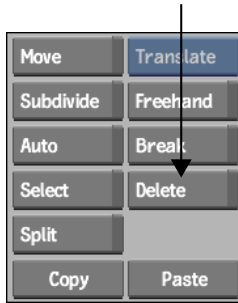

- 2 To delete a patch that lies along the boundary of the mesh, click the middle of the patch.
- 3 To delete a line that connects two patches that are not along the boundary, click both sides of the line.

Modifying a Mesh

Use the modelling controls in the Warper menu to modify the meshes to define the original and the final shape of the image. You can modify the shape and size of the patches or the location and orientation of the mesh, divide the patches into smaller subpatches, and split the edges into smaller segments.



NOTE The more detail you add to the mesh, the more control you have when warping or morphing a clip. However, if you have too much detail, the meshes may be difficult to modify.

If you cannot see the mesh properly against the colours in the image, you can customize the colours of the various meshes, as well as those of the splines, tangents, and vertices. See [Display Settings](#) on page 1908.

Moving Control Points, Edges, and Tangent Handles

You can manipulate control points and tangent handles on the mesh to add precision to your warp effect. Click the control points to access their tangent handles, then click the tangent handles to change the shape of a patch.

Click the Move button to move a vertex, an edge, or a tangent handle.

To:	Click:
Move a control point	The control point and drag. Note that the X, Y, and Z coordinates of the selected vertex appear in the corresponding fields in the menu.
Move an edge	Near the centre of the edge and drag.
Move a tangent handle	The corresponding vertex to display its tangents, then click the tangent handle and drag.

Selecting Multiple Control Points

Select multiple control points to translate, scale, or rotate all or part of the mesh while maintaining the spatial relationship between the selected control points.

To select multiple control points:

- 1 In Warper menu, click Select.

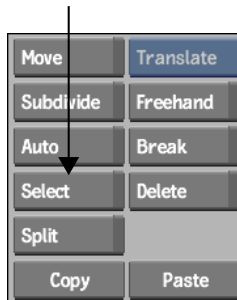

- 2 Hold down the **Ctrl** key and drag a selection box over the control points that you want to select.

NOTE To deselect individual points, click the points. To deselect all, click outside the area of selected control points.

Translating, Scaling, and Rotating the Mesh

Use the Translate, Scale, and Rotate options to change the position, size, and orientation of part or all of the mesh.

To translate, scale, or rotate the mesh:

- 1 Select the appropriate area of the mesh. See [Selecting Multiple Control Points](#) on page 1884.
- 2 In the Warper menu, select Translate, Scale, or Rotate.

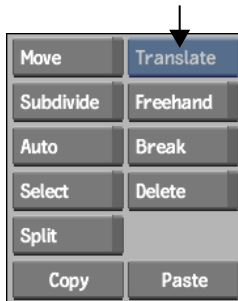

- 3 Click Move.
- 4 Click one of the selected control points and drag.
The selected area of the mesh is translated, scaled, or rotated.

NOTE You can also translate, scale, and rotate the entire mesh using the Translate, Scale, and Rotate channels in the Channel Editor. However, you cannot use the Channel Editor to affect only part of the mesh.

Breaking Tangents

By default, a vertex's tangents work together. Moving one tangent has the inverse effect on the opposite one to maintain a smooth curve at the vertex. In certain cases, you may want the tangents to move independently of each other.

Consider the mesh in the following example.

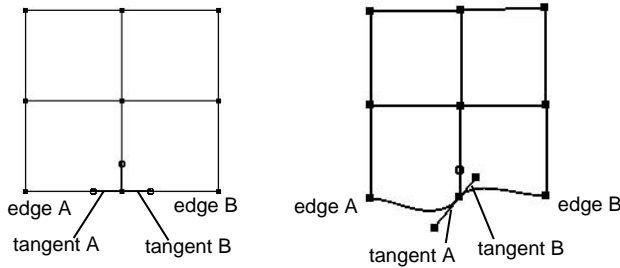

Suppose that you want to move tangent A to change the shape of edge A. Moving tangent handle A also causes tangent B to move in the opposite direction (as shown above); tangent A and tangent B are locked. You can use the Break command to break the tangents and move them independently (as shown here).

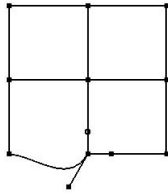

After using Break to break two tangents, you can use the Auto command to rejoin them. Note that resetting the tangents also resets the corresponding edges to their default positions.

To break tangent handles:

- 1 In the Warper menu, click Move.
- 2 Click a vertex to display its tangents.
- 3 Click Break, then click a tangent handle.

The tangent and the opposite one can now be moved independently. The tangent handles are solid indicating they are broken.

NOTE If the vertex has four tangents, click one handle of each pair to make all four tangents move independently.

To reset broken tangent handles:

- 1 In the Warper menu, click Move.
- 2 Click a vertex to display its tangents.
- 3 Click Auto, then click a tangent handle.
The tangents and edges are reset.

Subdividing a Patch

You can divide patches in a mesh into smaller subpatches and split the edges into smaller segments using the Subdivide button.

To subdivide a patch:

- 1 In the Warper menu, click Subdivide.



- 2 Click the edge of a patch and drag the cursor to the opposite edge.

NOTE To delete an edge created with Subdivide, enable Delete and click the edge.

Adding a Vertex

For more control when manipulating an edge, add a vertex to the edge.

To add a vertex:

- 1 In the Warper menu, click Split.

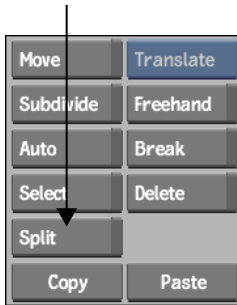

- 2 Click the edge of a patch where you want to add a vertex.

NOTE To delete a vertex created using the Split button, click Delete, then click the vertex.

Using the Freehand Mesh Tool

Use the Freehand Mesh tool to perform intricate mesh modelling.

To create a freehand mesh:

- 1 In the Warper menu, click Freehand.



- 2 Click the edge of a patch, and continue clicking until you complete the mesh.
- 3 **Ctrl**-click the final vertex.

To delete a freehand mesh:

- 1 Click Delete.

- 2 Click the spline or vertex you want to delete, or click Undo.

Warping with the Magnet Tool

Use the Magnet tool to define the shape of the warped image. The Magnet tool warps the area of the mesh under the Magnet. You can set the size of the Magnet and define its effect on the selected area.

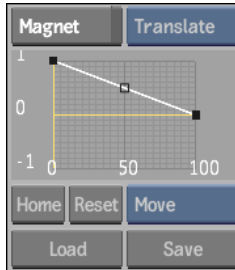

Note that the Magnet's effect is most noticeable when the selected area includes many control points (that is, when the grid has many patches, when you are using a large Magnet, or both).

To use the Magnet tool:

- 1 In the Warper menu, click Magnet.
- 2 Place the cursor over the mesh and adjust the Magnet size by pressing **Ctrl+S** and dragging.
- 3 Place the Magnet over the control points you want to warp and click. The affected control points turn red.
- 4 Drag the Magnet to produce the effect you want.

NOTE By default, the Magnet translates the mesh. To scale or rotate the mesh, select the Scale or the Rotate option in the selection box beside the Magnet button.

Customizing the Magnet's Effect

You can customize the Magnet's effect by changing the shape of the curve in the Magnet Curve Editor. Note that, by default, the Magnet has the greatest

effect on the pixels at the centre of the Magnet and the least effect on the pixels at its perimeter.

To customize the Magnet's effect:

- 1 In the Warper menu, click MEditor.
The Magnet Curve Editor appears.

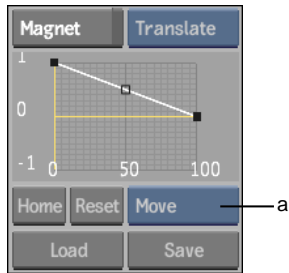

(a) Edit Mode box

- 2 Adjust the shape of the Magnet curve.
You can also use the Edit Mode options to modify the curve.

NOTE You can save and load custom Magnet settings using the Save and Load buttons in the Magnet Curve Editor.

Tips and Tricks

You can experiment with the Magnet curve to achieve different effects.

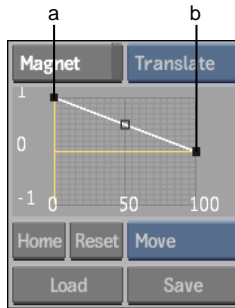

(a) Point representing effect at the Magnet's centre (b) Point representing effect at the Magnet's perimeter

- Invert the curve to affect the pixels at the perimeter of the Magnet more than those at the centre.
- Flatten the curve along the horizontal axis to have the same effect on all pixels under the Magnet.
- Add extra control points and create a sine or wave curve to make the control points move in opposite directions.
- Move the curve into the negative horizontal axis to create a magnet with an opposing magnetic effect.

Modifying the Meshes for Live-Action Clips

If you are warping or morphing a live-action or moving clip, you must define the source mesh at several frames in the clip. The Warper interpolates the location and shape of the mesh between frames.

Creating a mesh over the length of a live-action or moving clip can be time-consuming. To simplify the mesh-building process, create the mesh for the first frame of the required clip, then use the Stabilizer to generate the successive meshes.

NOTE You can track the source or destination mesh for either the front or the back clip.

With the Stabilizer, you can track the movement in the clip, and then apply the tracking data to the mesh (tracking by Axis). This translates the mesh so that it follows the movement in the clip without changing shape. Alternatively, you can track the movement of selected points in the image, and apply the

tracking data to the mesh (tracking by Vertices). This translates and changes the shape of the mesh so that it matches the position and shape of the image over the length of the clip.

Loading a Clip into the Stabilizer

Use the Stabilizer controls in the Warp menu (if you are warping) or in the Morph menu (if you are morphing) to select the clip you want to track, the mesh you want to apply the tracking data to, and the tracking mode.



Select:	To:
Front	Track the front clip.
Back	Track the back clip.
Axis	Apply the tracking data to the axis of the mesh. You can use one or two trackers in the Stabilizer.
Vertices	Apply the tracking data to the mesh control points (vertices). You must select the control points you want to track before entering the Stabilizer. You can track up to 1000 control points. Note that tracking by vertices sets a shape keyframe at every frame of the clip.
Source	Apply the tracking data to the source mesh of the selected clip.
Destination	Apply the tracking data to the destination mesh of the selected clip. This option can be useful if front and back destination meshes are different.

See [Stabilizing](#) on page 1793.

Tracking by Axis

To make the mesh follow the movement in the clip without changing shape, apply the tracking data to the mesh axis.

To track by axis:

- 1 Set the Stabilizer controls to apply the tracking data to either the Source or Destination mesh for either the Front or Back clip.
- 2 Select Axis.
- 3 Click the Stabilizer button.
The Stabilizer menu appears.
- 4 Position the tracker on the image. See [Working with Trackers](#) on page 1785.
- 5 To use two trackers, click Tracker 2, click Active, and position the second tracker on the image.
- 6 Click Analyse to generate the tracking data.
- 7 If necessary, fine-tune the analysis.
- 8 When you are satisfied with the tracking results, click Return to apply the results and return to the Warper.

Tracking by Vertices

To make the mesh follow the movement and shape change in the clip, apply the tracking data to the mesh vertices.

To track by vertices:

- 1 Select the mesh control points that you want to affect. See [Selecting Multiple Control Points](#) on page 1884.
- 2 Set the Stabilizer controls to apply the tracking data to either the Source or Destination mesh for either the Front or Back clip.
- 3 Select Vertices.
- 4 Click the Stabilizer button.
The Stabilizer menu appears. A tracker appears on each vertex that you selected. The reference frame is the frame from which you opened the Stabilizer.
- 5 If necessary, adjust the position of the trackers to ensure that each tracker has a good reference point.
- 6 Click Analyse to generate the tracking data, and if necessary, fine-tune the analysis.

For example, disable a problem tracker and re-analyse, as described in [Tracking Difficult Shots and Correcting Errors](#) on page 1805.

- 7 When you are satisfied with the tracking results, click Return to apply the results and return to the Warper.

Copying and Pasting Tracking Data

You can copy and paste tracking data from one mesh to another using the Channel Editor. For example, if tracking was done using Axis, you can copy the translation of the front source mesh and apply it to the back source mesh.

To copy translation data:

- 1 Click Animation to view the Channel Editor.
- 2 Select the X and Y channels in the front_src translate folder.
- 3 Click Copy.
- 4 Select the X and Y channels in the front_dst translate folder.
- 5 Click Paste.

The translation channels containing the tracking data from the front source mesh are pasted into the front destination mesh.

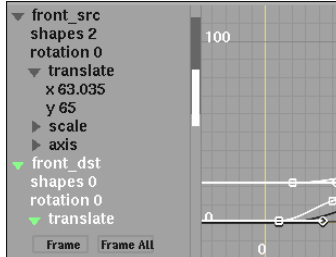

If tracking was done using Vertices, you can copy the shape animation of the front source mesh and apply it to the front destination mesh.

Example: To copy shape animation data:

- 1 Select the front_src shapes channel.
- 2 Click Copy.
- 3 Select the front_dst shapes channel.

- 4 Click Paste.

The shapes channel containing the tracking data from the front source mesh is pasted into the front destination mesh.

Copying and Pasting Meshes for a Live-Action Clip

For a live-action clip, use the Channel Editor to copy the shapes curve of one mesh and paste it into another mesh. The shape and translation of the mesh at each frame are copied.

To copy and paste meshes for a live-action clip:

- 1 Create the mesh at the first frame of a clip and modify it over several frames to define the movement in the clip.
- 2 Click Animation to view the Channel Editor.
- 3 Select the shapes channel for the mesh you are copying (front_src, front_dst, back_src, or back_dst).
- 4 Click Copy.
- 5 Select the shapes channel for the mesh that you want to be the same as the copied mesh (front_src, front_dst, back_src, or back_dst).
- 6 Click Paste.

NOTE If Auto Key in the Setup menu is enabled, a keyframe is created in the associated animation channel at the current frame every time the mesh is copied to a new frame and modified. When you copy the shapes curve to a new mesh, you copy the mesh and all its keyframes.

Copying and Pasting Meshes for a Still Clip

For a still clip, use the Copy and Paste buttons in the Warper menu to copy a mesh and paste it into another mesh.

To copy and paste meshes for a still clip:

- 1 Create the mesh at the first frame of the clip.
- 2 Click Copy in the Warper menu to copy the mesh—including its translation, scale, and rotation values.

- 3 Go to the required frame and display the mesh (source or destination) where you want to paste the copy.
- 4 Click Paste.

Warping

Warping changes the shape of the image in a clip. When you warp an image, you start by drawing a mesh over the region of the image you want to warp. You then modify the mesh over the image at specific keyframes to distort the image.

To create the warp, define a source mesh and a destination mesh for the front clip. The source mesh defines the area of the image that you want to warp; it outlines the shape of the non-distorted image in each frame of the clip. The destination mesh defines what the warped image looks like; it outlines the shape of the distorted image in each frame of the clip. Typically, you set the destination mesh at several frames of the clip. The Warper generates a smooth transition between frames.

The general steps for warping:

- 1 Load the appropriate clips into the Warper. If you are warping just a region of the clip, load the same clip as the Front and the Back clip. See [Warping a Region of a Clip](#) on page 1898.
- 2 In the Warper menu, click Warp.
- 3 Set up the clips. See [Setting Up the Clips](#) on page 1879. In general:
 - Set Front to On.
 - If you are warping just a region of the clip, set Back to Lock.
- 4 Click Front to view the front clip.
- 5 Define the source mesh for the original image.
- 6 Define the destination mesh for the warped image.
- 7 Process the clip.

Defining the Source Mesh

Use the modelling tools to define the source mesh so that it outlines the original shape of the image in the front clip.

To define the source mesh for the original image:

- 1 Go to the first frame of the clip.
- 2 Click Front Source to define the source mesh for the front clip.
- 3 Add a mesh over the area to warp and modify its shape to match the original image.
- 4 If you are using a live-action or moving clip, the source mesh must follow the movement of the image. You can either modify the mesh manually throughout the clip, or use the Stabilizer to track the movement in the clip. See [Modifying the Meshes for Live-Action Clips](#) on page 1891.

Defining the Destination Mesh

Set the destination mesh to be the same as the source mesh at the first frame, then change the shape of the destination mesh at different frames of the front clip to outline the required shape of the distorted image.

To define the destination mesh for the warped image:

- 1 Click Front Source.
- 2 Go to the first frame in the clip.
- 3 Click Copy to copy the source mesh.
- 4 Click Front Destination to select the destination mesh for the front clip.
- 5 Click Paste to paste the copied mesh into the destination mesh.
- 6 At several frames in the clip, modify the destination mesh to outline the required shape of the warped image.

TIP In the view box, select Result to see the pixels move as you move the mesh points.

- 7 When you finish modifying the meshes, go to frame 1 and click Process to process the clip.

Warping a Still Clip

To warp a still clip, you define the source mesh only for the first frame of the clip since the object to warp has the same shape and location in each frame of the clip. Typically, you have to define the destination mesh only for the first and the last frames of the clip. The Warper generates a smooth transition between the two frames.

The following illustration shows the source and destination meshes used to warp a square into an oval.

Source Mesh:

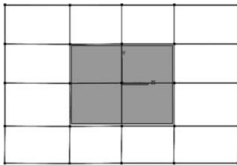

First Frame



Last Frame

Destination Mesh:

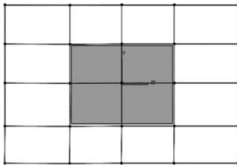

First Frame

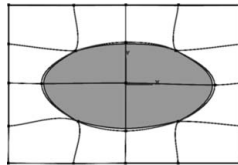

Last Frame

Warping a Region of a Clip

When a clip is processed, only the area defined by the mesh is processed. If you want to warp only a region in an image (known as regional warping), but you want to see the entire image in the result, you must load the same clip as the front and the back clip, and then lock the back clip.

Morphing

Morphing gradually transforms an image in a front clip into an image in a back clip. The effect is achieved by warping the two images and dissolving between the front and back clips. Unlike warping, which requires only a front source mesh and a front destination mesh, morphing requires a source mesh and a destination mesh for both the front clip and the back clip.

The front source mesh defines the original shape of the image in each frame of the front clip. Similarly, the back source mesh defines the original shape of the image in each frame of the back clip.

NOTE You should create the mesh over a slightly larger area of the image than just the part you want to affect. See [Defining a Mesh](#) on page 1881.

Both the front and the back destination meshes correspond to the warped image. Since the front clip transforms into the back clip:

- At the first frame, the front and back destination meshes correspond to the shape of the front clip.
- At the last frame, the front and back destination meshes correspond to the shape of the back clip.

The general steps for morphing:

- 1 Load the appropriate clips into the Warper. You need to load at least a front clip and a back clip.
- 2 In the Warper menu, click Morph.
- 3 Set up the clips (see [Setting Up the Clips](#) on page 1879). In general:
 - Set Front to On.
 - Set Back to On.
- 4 Click Front to view the front clip.
- 5 Define the front source mesh to match the shape of the front clip at each frame.
- 6 Define the back source mesh to match the shape of the back clip at each frame.

- 7 Define the front and back destination meshes. You can either use Source interpolation to automatically modify the destination meshes or copy and paste the meshes and set the keyframes manually.
- 8 When you finish modifying the meshes, go to frame 1 and click Process to process the clip.

Defining the Front Source Mesh

The front source mesh defines the original shape of the image in each frame of the front clip.

To define the source mesh for the front clip:

- 1 Go to the first frame of the clip.
- 2 In the Morph menu, click Front Source.
- 3 Add a mesh over the area to be morphed and modify its shape to match the image.
- 4 Make the front source mesh match the image at each frame of the front clip. You can either modify the mesh manually or use the Stabilizer to track the movement in the front clip.

Defining the Back Source Mesh

The back source mesh always contains the same number of control points and patches as the front source mesh. Copy the front source mesh to use as a starting point, then adapt the mesh shape to the image at each frame of the back clip.

If you are using the Stabilizer and you need more detail for the back source mesh, add subdivisions to the mesh. Be sure to add the same subdivisions to the front source mesh.

NOTE Enable the Fixed button in the Stabilizer menu.

To define the source mesh for the back clip:

- 1 Go to the first frame of the clip.
- 2 Click Front Source, then click Copy to copy the front source mesh.

- 3 In the Morph menu, click Back Source to select the back source mesh.
- 4 Click Paste to paste the copied mesh into the back source mesh.
- 5 Click Back to view the back clip.
- 6 Modify the back source mesh to match the image in the back clip at each frame. You can either modify the mesh manually or use the Stabilizer to track the movement in the back clip.

Using Source Interpolation

Use source interpolation to automatically define the destination meshes. Source interpolation automatically creates the transition from the front source mesh at the first frame to the back source mesh at the last frame of the clip.

NOTE If you want to add another effect, such as scaling, during the morph, do not use source interpolation. You must define the front and back destination meshes manually at several frames. See [Setting Keyframes Manually](#) on page 1902.

Dissolve and Interpolation Curves

Source interpolation uses two predefined animation curves—dissolve and interpolation—to calculate the percentage change from the front source mesh to the back source mesh over the length of the clip. These values are set in the Dissolve and Interpolate fields:

- The Dissolve field defines the percentage change in the colour of the pixels at the current frame.
- The Interpolate field defines the percentage change in the position of the pixels at the current frame.

The default values in these fields are 0% at the first frame and 100% at the last frame. Using the default values results in a smooth dissolve from the pixels in the front image to those in the back image, as well as a smooth transition from the shape of the front image to that of the back image. You can change the rate of the morph by changing the interpolation and dissolve values.

To use source interpolation:

- 1 Click Morph to display the Morph menu.
- 2 Under Mapped To, select Source Interp to use source interpolation for the Front Destination mesh and Back Destination mesh.

Meshes			Mapped To
Front Source	Show	<input type="checkbox"/>	Front Source
Front Destination	Show	<input type="checkbox"/>	Source Interp
Back Source	Show	<input type="checkbox"/>	Back Source
Back Destination	Show	<input type="checkbox"/>	Source Interp
Source Interp	Show	<input type="checkbox"/>	

(a) Source interpolation option for the front destination mesh (b) Source interpolation option for the back destination mesh

- 3 Enable Curves to activate the interpolation and dissolve curves.

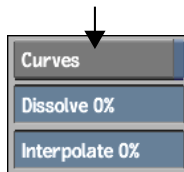

- 4 In the View box, select Result to view the result, and play the clip.

To change the rate of the morph:

- 1 In the Warper menu, click Animation to display the Channel Editor.
- 2 Select the dissolve or the interpolate channel.
- 3 Modify the curve.

Setting Keyframes Manually

If you are not satisfied with the source interpolation result, you can set the keyframes manually. However, you will have to set the keyframes throughout the clip—you cannot use source interpolation in conjunction with manual keyframes.

To set a keyframe manually:

- 1 Go to the frame corresponding to the keyframe you want to set.

- 2 Click Front Destination to display the front destination mesh.
- 3 Modify the mesh.
- 4 Copy the front destination mesh and paste it into the back destination mesh for that frame.

Alternatively, if you want the back destination mesh to always match the front destination mesh, select the Front Destination under Mapped To adjacent to the Back Destination Meshes button.

Morphing Between Two Still Clips

To morph between two still clips, you define the source meshes only for the first frame of the front and back clips (since the objects have the same shape and location in each frame of the clips). You can use source interpolation to create a smooth morph.

The following illustration shows the source and destination meshes needed to morph a square into a circle.

Front Source Mesh:



First Frame



Last Frame

Back Source Mesh:

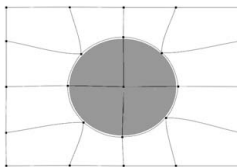

First Frame

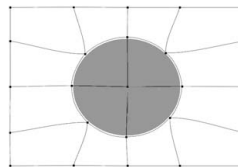

Last Frame

Front and Back Destination Meshes:

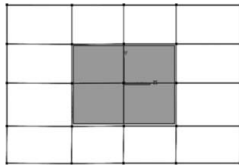

First Frame

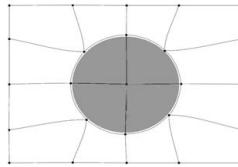

Last Frame

Morphing Between Two Live-Action Clips

To morph between two live-action clips, you have to define the source and destination meshes for the front and back clips for the duration of the clips—since the objects change shape and location in each frame of the clips. You can use the Stabilizer to track the movement of the objects and source interpolation to create a smooth morph.

The following illustration shows the source and destination meshes needed to morph a square into a circle, both moving from the upper-left to the lower-right corner of the image window.

Front Source Mesh:

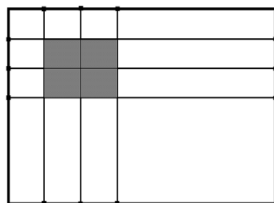

First Frame

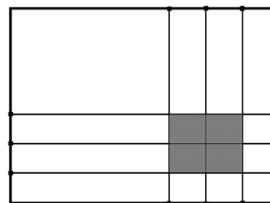

Last Frame

Back Source Mesh:

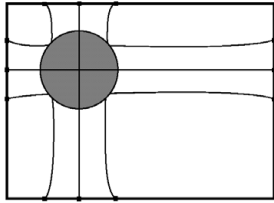

First Frame

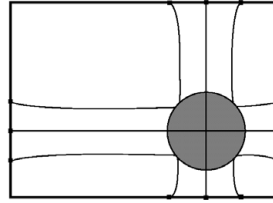

Last Frame

Front Destination Mesh:

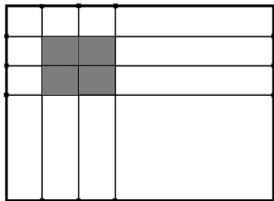

First Frame

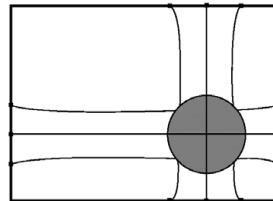

Last Frame

Back Destination Mesh:

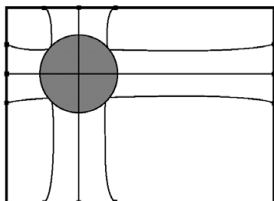

First Frame

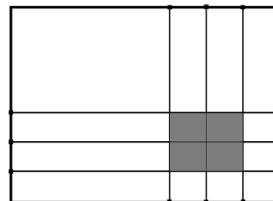

Last Frame

Setup Options

From the Setup menu, you can customize display colours and set processing options.

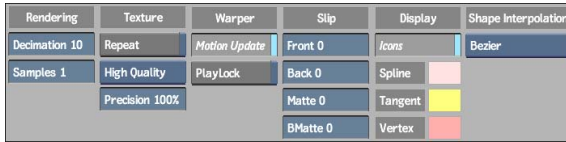

Rendering Settings

Use the Rendering settings to improve the final output quality of your image.

Decimation Decimation is the number of subdivisions for the main patches of the mesh (not the small subdivided elements). The default decimation value is 10, which means that each patch is divided into 10 by 10 elements. You should increase this value when:

- You want to use smoother curves along the edges of the patches.
- A patch has been greatly subdivided. When the Decimation value is too low, the subdivided sections will appear to “swim” instead of locking to points and splines.
- A patch is twisted extensively. When the Decimation value is too low, the interior of the patch may appear to fold or break up unexpectedly. Increase the value to smooth the interior of the patch.

Keep the following points in mind when you are adjusting the decimation value:

- Increasing the Decimation value will cause interaction and processing speed to decrease dramatically.
- The Decimation value remains in effect during final processing.
- There is no relationship between the Decimation value and the TexPrec value. The Decimation value defines the precision of the geometry, whereas the TexPrec value affects the precision of the image that is mapped to this geometry.

Samples The Samples field specifies the anti-aliasing factor. This number specifies the number of samples per pixel during final processing.

Texture Settings

Use the following controls to choose between hardware texture-mapping or polygons for processing.

Repeat Specifies how pixels are handled when a source mesh goes outside of the borders of an image. When this button is disabled, anything outside of the image is considered black. When the button is enabled, the image is repeated. TexRepeat is disabled by default.

Texture Quality Provides three texture rendering options.

Select:	To:
High Quality	Use high-quality hardware texture rendering. This option always uses the highest level of precision. High Quality tiles images according to the available texture memory. This option is the default and is the recommended rendering option for film images or any image that is greater than the available texture memory.
Low Quality	Use low-quality hardware texture rendering, specifically during interactive rendering mode or when you want to render an image quickly. This option uses the precision level that you set in the Precision field.
Pixel Rendering	Use polygon rendering.

Click Preview to hide the mesh and preview the resulting frame.

Precision (Texture/Precision Ratio) Indicates a speed/quality ratio for interaction as well as the rendering quality when Low Quality is selected as the rendering option. The higher the value, the higher the quality of the display during interaction, and the higher the quality of final processing when rendering under Low Quality.

Warper Settings

Use these settings to define general warper properties.

Motion Update button Updates properties such as position, rotation, and colour in the scene. This button is enabled by default.

When disabled, animated objects do not move, but keep the position of their current value. Disable Motion Update when you want to copy keyframe values from one frame to another.

Play Lock button Updates the animation settings according to the frame or timebar position as you move through the clip while keeping it locked at the current frame.

Slip Settings

Slips a clip by a specified number of frames. Click in the field for the clip you want to slip and enter the number of frames. The first frame of the clip will be repeated by the number specified to result in a delayed start.

Select:	To slip:
Front	The front clip.
Back	The back clip.
Matte	The front matte.
BMatte	The back matte.

Display Settings

Enable the Icons button to display splines, tangents, and vertices in the image. You can also customize the colours of splines, tangents, and vertices using the colour pot next to each button.

Topics in this chapter:

- [About Text](#) on page 1909
- [Accessing the Text Module](#) on page 1910
- [Processing Text](#) on page 1913
- [Saving and Loading Files](#) on page 1918
- [Adding Text to Clips](#) on page 1921
- [Creating Text Effects](#) on page 1926
- [Loading Logos](#) on page 1934
- [Tabulating Text](#) on page 1935
- [Spell Checking](#) on page 1936
- [Creating Text Rolls and Text Crawls](#) on page 1937
- [Animating Text](#) on page 1941
- [Defining Styles](#) on page 1947
- [Changing Fonts](#) on page 1950

About Text

Text is comprised of layers, paragraphs, and characters. You can make text spin, dance, and change colour over time. You can also create effects such as a text roll of credits, text crawls, bumpers, and text that moves on a motion path. You can use logo images in a text roll so that the logo of a sponsor appears in the credits list.

You use the Text module to add text and text effects to a clip. Once text effects are applied to a clip, you can then use the clip in the Action or Batch module depending on the final effect you want to achieve. Use Action to create 3D text deformation effects, including sliding, magnifying, and oscillating effects. For example, to create an effect of text rolling on a cylinder in a composite, you first render a text roll in Text and then, in Action, project it as a texture onto a cylinder. See [Adding Textures](#) on page 2284.

Text Workflow

The following table shows the recommended workflow for creating text in the Text module.

Step:	Refer to:
1. Determine whether the text will appear over a clip, a black background, or a coloured frame.	Accessing the Text Module on page 1910.
2. Set text processing options.	Processing Text on page 1913.
3. Determine whether you want to create a text roll, a text crawl, or text on a path or standard layer.	Creating Text Rolls and Text Crawls on page 1937.
4. Create a layer.	Adding Text to Clips on page 1921.
5. Set the position, size, and offset of the layer.	Modifying Layer and Character Properties on page 1928.
6. Enter text or load an existing text file.	Entering Text on page 1922 and Loading Text Files on page 1919.
7. Set text attributes.	Creating Text Effects on page 1926.
8. Preview the result and process the final clip.	Processing Text on page 1913.

Accessing the Text Module

When accessing the Text module, you first select whether to add text to a source clip, a coloured frame, or a black background. The first time you open

the Text module, the frame contains a clip image, but no text. The next time you open it, the text and settings from the previous Text session appear.

To access the Text module:

- 1 In the Main menu, click Effects.
- 2 In the Desktop menu, click Text.
- 3 From the Input Mode box, select Back or None.

TIP If you want to change the Input mode to None once in the Text module, you can do so from the Text Setup menu. See [Processing Text](#) on page 1913.

- 4 If you selected None, choose a resolution, width, height, pixel aspect ratio, bit depth, scan mode, and frame depth to apply to the background in the Text module.



- 5 If you selected Back, select the source clip to which you want to add text from the Desktop.
- 6 Select a destination for the processed clip.
The Text module appears.
- 7 If text from a previous Text session appears, click Reset All.
The Text module is cleared and settings are reset to their default settings.
- 8 To delete any layers from a previous session, click Delete All.

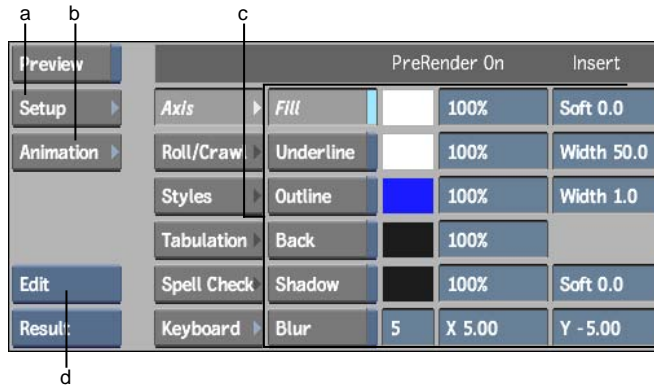

(a) Setup button (b) Animation button (c) Attribute controls (d) Text Mode box

The Text controls are described as follows.

Axis button Opens the Axis menu to set properties for layers and characters. See [Modifying Layer and Character Properties](#) on page 1928.

Roll/Crawl button Sets text motion properties for vertical or horizontal text scrolling. See [Creating Text Rolls and Text Crawls](#) on page 1937.

Styles button Creates preset text style formats. See [Defining Styles](#) on page 1947.

Tabulation button Tabulates text. See [Tabulating Text](#) on page 1935.

Spell Check button Checks text for spelling errors. See [Spell Checking](#) on page 1936.

Keyboard button Opens the on-screen keyboard to enter text. See [Using the Text Keyboard](#) on page 1925.

Attribute controls Changes the appearance of text by setting properties such as fill and shadow. See [Creating Text Effects](#) on page 1926.

Setup button Displays the Text Setup menu. See [Processing Text](#) on page 1913.

Animation button Creates a text animation by setting different text properties at specific keyframes in a clip. See [Animating Text](#) on page 1941.

Text Mode box Applies various text settings to layers, paragraphs, and characters. Use text modes to manipulate layers, add text to a clip, or edit existing text in a clip. See [Modifying Layer and Character Properties](#) on page 1928.

The message bar displays the mode that is currently enabled.

Processing Text

Before processing a text clip and rendering text effects, you must set crop settings for the text layer, blur settings, text animation, softness, and whether or not you want to use prerendering. The prerendering feature accelerates the rendering process for a text layer.

Set text processing options in the Text Setup menu. To access the Setup menu, click Setup. The Setup controls are described as follows.



Auto-Softness box Sets the auto-softness and sampling level. Auto-Softness mode is set by default and provides a softness equal to the display quality you see in the Text module.

Anti-aliasing values can range from 1 to 64. A higher value increases the sampling rate, but also increases processing time. An anti-aliasing of 1 means no anti-aliasing is performed and the result is a hard edge.

TIP A higher anti-aliasing value is usually needed with outlined text.

Softness box Defines the softness of the anti-aliasing samples.

PreRender button Accelerates rendering on a static layer only, such as a text roll. PreRender has no effect on text layers with animation.

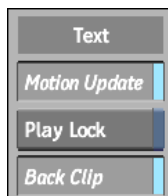

Motion Update button Controls the playback of animated text. When enabled, animated text is updated dynamically in the image area when you play the clip.

Play Lock button Controls the playback of frames and displays the playback of animated clips exclusively. When enabled, the first frame is locked while you play the clip.

Back Clip button Enables or disables the back clip in the scene. If you entered the Text module with a back clip, you can disable it here.



Crop button Creates a custom-sized crop box. Use this box to define an area in which to render text. When working with a crop box, you view all text, whether it is inside or outside the crop box. You can use the Left, Right, Bottom, and Top fields to set the size of the crop box. You can also drag the vertices at the corners of the crop box in the image window.

Crop Border button Displays a coloured border representing the crop area. You can change the colour by clicking the colour pot.

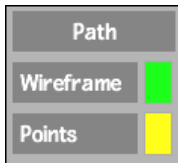

Wireframe colour pot Sets the colour of the text path. See [Animating Text on a Motion Path](#) on page 1944.

Points colour pot Sets the colour of the vertices on a text path. See [Animating Text on a Motion Path](#) on page 1944.

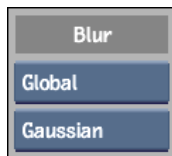

Global/Layer Blur box Sets Global Blur (default) or Layer Blur. Global Blur makes all shadows appear together, blurred with a single unique colour, on top of the background of all layers. Layer Blur blurs each layer individually according to its priority—background, blurred shadow, and fill.

When using Global Blur with prerendering, the layers are prerendered once and blurred on the front clip. These layers must not have any animation—they are static. For Layer Blur, there are two possible cases:

- All layers are static, without background. Only fill or shadow can be enabled for all layers—no blur. The layers are prerendered once and blurred on the front clip.
- Auto-Softness On, Progressive Rendering, or All Layers Static. Static layers (up to two) are prerendered once and blurred on the front clip as other layers are rendered.

Blur box Sets Gaussian Blur or Box Blur. Gaussian Blur uses subpixel resolution and creates a subtle effect with the Blur Shadow attribute. Gaussian has rounded, smoother edges and is better for animation; however, processing time is increased.

Box Blur has rectangular, rougher edges, but is more economical with processing time, especially if you are working on a rough draft.

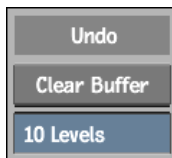

Clear Undo Buffer button Resets the Undo entries.

Undo Levels field Changes the levels of Undo available in the Undo/Redo lists. The maximum level of undo is 20.

Processing Text Clips

You can process clips in progressive or interlaced rendering. Interlaced rendering produces a better result, especially if you use keyframes that are far apart, but it takes longer to process. You should preview the quality of the image and the text before you process the final clip. In addition, you can process a clip to generate a matte for the text. See [Generating Text Mattes](#) on page 1916.

To process a clip with text:

- 1 From the Rendering box, select Interlaced, Progressive, or As Back (to render using the mode of the back clip).



- 2 Click Setup.
- 3 From the Setup menu Rendering section, select the sampling level from the Auto-Softness box.
- 4 Set other options as required.
- 5 Position the clip at the first frame or the specific frame where you want to start processing.
- 6 Click Preview.

TIP You can zoom (**Ctrl+spacebar**) or pan (**Ctrl+Shift+spacebar**) the image window while in Preview mode. To disable Preview, make a modification to the text or processing options, or click anywhere in the image window.

- 7 Make modifications to the text and processing options and preview until you are satisfied with the result.
- 8 When you are ready to process the text clip, click Process.
The clip is processed from the currently displayed frame until the end of the clip.

Generating Text Mattes

Generating the matte for text enables you to work with the text independently from the underlying media and to use the text in other modules. By generating a matte, you can easily composite the text onto another clip. While creating text using a gap effect produces a similarly independent text element, generating a text matte has the advantage that you can use the text in effects

that call for a front, back and matte clip. Furthermore, combining a back and matte clip with an Axis effect allows you to manipulate the text without affecting the underlying clip.

When creating a matte from text, the transparency of the text's fill attribute is handled according to the processing option selected: Process, Matte, or Both. The Process option does not create a matte, and the transparency is applied, as expected, to the text on the back layer. Selecting Matte produces a matte only, and transfers the text's fill transparency to the matte. This produces the desired result when compositing the text and its matte with a background. That is, it yields a composite image in which the text has a transparency. The Both option results in a back and a matte clip; note, however, the fill transparency is stripped from the text and once again transferred to the matte.

To generate a matte for text:

- 1 Create effects using the Text module, as desired.
- 2 From the Process box, select one of the following to process the text and/or matte of the text.

Select:	To:
Process	Process only the text on the back layer.
Matte	Process only the matte of the text. The text fill transparency attribute is transferred to the matte.
Both	Process the text on the back layer and the matte of the text. The fill transparency is removed from the text and transferred to the matte.

The matte of the text appears on the Desktop.

In Batch, the Use Transp button determines how the transparency attribute is applied. Enable Use Transp to transfer the transparency attribute to the matte. Disable it to leave it on the back clip.

Processing Considerations

Processing is contingent upon PreRender, Blur, and Animation settings. Depending on which options you choose, you can increase the processing speed:

- When more than one non-static layer has blur shadows, Global Blur is faster, although all shadows are blurred with the same unique colour and appear under all other layers.
- When there is a combination of animated and non-animated layers, speed depends on the blur shadows. If animated text has blurred shadows, Global Blur is faster. If you want a static blurred shadow, and a non-blurred animated layer, Layer Blur is faster.
- If you have static layers only (no animation), speed depends on the number of layers and whether PreRender can be used. Global Blur is faster since it uses PreRender. The processing speed of Layer Blur is the same with one or two layers. However, it becomes progressively slower with a higher number of layers and if the layers use blur shadows.

Saving and Loading Files

You can save, load, and import text files, text setups, and images for specific use with the Text module. You can save text, text effects, text preferences, layers and new default text settings.

You can load text files from third-party word processing packages, existing Text module setups, and logos. Loading existing text files is particularly convenient if you are creating a long text roll of credits as it saves time that you would otherwise spend typing and spell checking.

Saving Text Files

When saving files, you can save text setups, preferences, and default settings.

To save a file:

- 1 Click Save.
- 2 In the Save menu, select an option from the Save box.

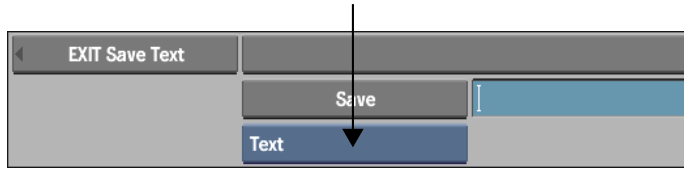

Select:	To:
Defaults	Override the default menu options in the Setup menu and replace them with your specifications.
Preferences	Save Setup menu specifications only and omit text and text attributes.
Selected Path	Save any selected text paths.
Selected Logos	Save any selected logos.
Selected Layers	Save selected layers, their text, text attributes and Setup menu options.
Text	Save text files with text attributes and Setup menu options.

- 3 Navigate and choose the directory where you want to save the file.
- 4 Type a name for the file and press **Enter** or click the Save button.
The file is saved and you return to the Text menu.

Loading Text Files

You can load text files, preferences, and ASCII files. You can also reset the Text menu settings with its factory defaults.

To load a file:

- 1 Click Load.
- 2 In the Load menu, select an option from the Load box.

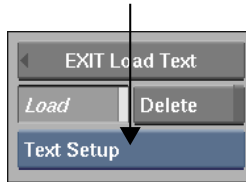

Select:	To load:
Preferences	Setup menu options that you have saved.
Path	<p>Previously saved text path setups. Setups between text paths and garbage masks are interchangeable. Therefore, you can also load a garbage mask shape as a path.</p> <hr/> <p>NOTE Preset paths are available in the <i>user/discreet/<product home>/path/default</i> directory.</p>
Logo	Previously saved logos.
Text File	<p>Text files. When you select Text File, you can select the encoding of the loaded file. This applies the correct conversion from the selected file's encoding to the application's internal encoding. For example, select ISO8859-1 to import Latin-1 ASCII files, or UCS-2 to import 2-byte Unicode encoded text files.</p> <p>The encoding options reflect the character encodings available with your system. The load mechanism supports the same encodings as the iconv utility. Optional iconv converters are available by installing national language support options.</p>
Multiple Text Setup	Several layers or text files at a time with preferences. Text module preferences that were saved with the selected file are loaded as well.
Text Setup	A layer or text file created in the Text module. Text module preferences that were saved with the selected file are loaded as well.
Factory Defaults	The original Text module settings that were delivered with Flame.

- 3 Choose a directory in either Proxies or Titles mode.
- 4 Select the file that you want to load in the file browser. If you selected Multiple Text Setup, **Ctrl**-click the files you want to load.

NOTE If you do not select Multiple Text Setup and you use the **Ctrl** key to load multiple text files, only the last selected file is loaded.

- 5 If you are loading a text file or text setup, you can click anywhere in the user interface to abort the load before it is completed.
- 6 To discard unwanted files, enable Remove.
- 7 If necessary, click Exit Load Text to exit the file browser.

Adding Text to Clips

You add text to a clip by first creating a layer for entering the text, setting the layer attributes, and then typing the text. You can create several layers of text that overlap each other.

Creating a Layer

Text is contained in a layer called a text layer. When you create a text layer, a coloured border called the *crop border* appears in the image window indicating the region the text will occupy.

To create a layer:

- 1 Click New Layer (or press **Alt+N**). If this is the first layer you are creating, you can click directly in the image window.



The text layer is positioned in the upper-left corner of the safe title area by default. The text in the layer is left justified, while the width is equal to the safe title overlay. You can modify the safe title overlay using the Grid and Guide controls. See [Working with Grids and Guides](#) on page 116. You can also modify the boundary colour. See [Processing Text Clips](#) on page 1915.

- 2 Click Axis to make sure you are in the Axis menu.
- 3 To set the text layer dimensions, enable Layer.

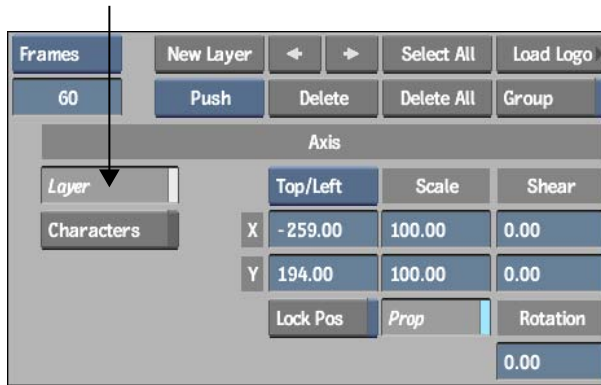

Each layer has its own parent axis for translating, rotating, resizing, and shearing. The axis for the layer can be in the upper-left or centre of the layer. See [Creating Text Effects](#) on page 1926.

Entering Text

The text you type may be as short as one letter or word or as long as several paragraphs. If the text is long or exists in a word processor, you can load the text file into the current layer.

You enter and edit characters much like in a word processor. You type characters using the keyboard and many known text editing conventions, such as **Shift+arrow keys** to select text lines. You can also click once to insert the cursor and select the adjacent character, double-click to select the whole word, and triple-click to select the entire line. Quadruple-click to select all characters on the layer and use the middle mouse button to paste selected text.

Use either the workstation or on-screen keyboard to enter characters in a layer. You can also paste the current text selection (from a shell or any other application) into any keyboard input field by pressing the middle mouse button or by using the pen button.

You can also input Asian characters using their corresponding ASCII codes with the numeric keypad.

To enter text in a layer:

- 1 From the Text Mode box, select Edit.

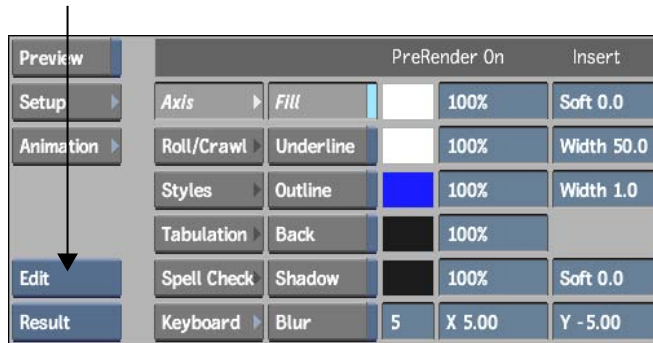

TIP Use Edit mode to type text strings, select text, edit text in layers, and modify text attributes. Press **Esc** to switch between Edit and Move modes. The message bar displays the current mode.

- 2 In the image window, create a new layer by doing one of the following:
 - Click New Layer.
 - Press **Alt+N**.
 - Click directly in the image window (if this is the first layer you are creating).

- 3 To begin a new paragraph within the layer, press **Enter**.
 Notice that each paragraph has its own coloured boundary and a paragraph tag that is a coloured rectangle in the upper-left corner of the paragraph. In Edit mode, a selected paragraph's boundary is white.

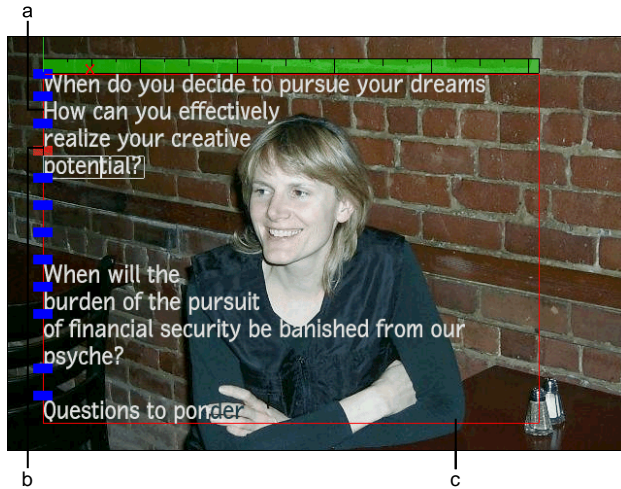

(a) Blue indicates paragraphs in text layer (b) Red indicates currently selected paragraph, which has a paragraph boundary (c) Layer boundary is shown in red

4 In the Paragraph and Font menus, set properties.

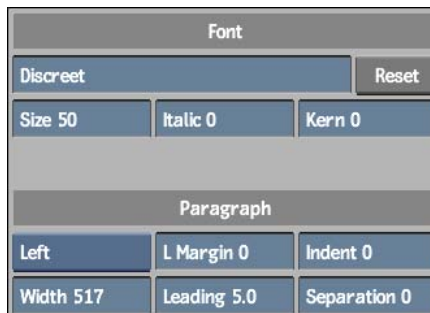

The Font and Paragraph controls are described as follows.

Font field When clicked, opens the font browser, which you can use to change fonts.

Font Size field Determines character size for the selected font.

Font Italic field Adjusts the angle of italicized text. Positive values make the characters slope to the right. Negative values make them slope to the left.

Font Kerning field Adjusts the spacing between characters. Positive values increase the spacing. Negative values decrease the spacing.

Justification box Aligns paragraph text. Select Left, Right, Centre, or Justified.

Width field Specifies the width of the layer.

L. Margin field Specifies the left margin.

Indent field Specifies the left indentation for the first line in the paragraph.

Leading field Specifies the space between lines in the selected paragraph.

Separation field Specifies the space between the selected paragraph and the one above it.

Using the Text Keyboard

When you use the on-screen keyboard, consider the following:

- Special characters use the ISOLatin1 encoding vector. You specify the encoding vector in the *init.cfg* configuration file using the FontMapping keyword. See the *Autodesk Visual Effects and Finishing Configuration File Reference Guide*.
- The extended keyboard uses the Standard encoding vector.
- Asian character sets may not display all characters on the on-screen and extended keyboards. Use the numeric keypad or load an ASCII file that contains unavailable characters for the selected font. See [Loading Text Files](#) on page 1919.

To use the Text keyboard:

- 1 In the Text menu, click Keyboard.
- 2 On the on-screen keyboard that appears, enable Up ASCII to display extended characters contained in the selected font set.



NOTE Enabling Up ASCII also affects your workstation keyboard, so make sure you disable the button again before exiting the Text menu.

- 3 Type the characters in the text layer.
The keyboard characters appear in the current font.

Word Processing Hot Keys

Typical word processing tasks include text selection, cutting, copying, and pasting. The Text module includes several character manipulation hot keys for these tasks.

Press:	To:
Alt+A	Select all characters in the selected text layer.
Alt+P	Select all characters in the selected paragraph within a layer.
Alt+Shift+A	Select all characters in all layers. This operation is the same as using the Select All Layers button.
Shift+up arrow	Extend the selection one line up.
Shift+down arrow	Extend the selection one line down.
Shift+left arrow	Extend the selection one character to the left.
Shift+right arrow	Extend the selection one character to the right.
Shift+Home	Extend the selection to the beginning of the current line.
Shift+End	Extend the selection to the end of the current line.
Ctrl+Shift+PgUp	Extend the character selection to the beginning of the text layer.
Ctrl+Shift+PgDn	Extend the character selection to the end of the text layer.

Creating Text Effects

Use the Attributes controls to change the appearance of individual characters, paragraphs, and layers. You set similar properties for both layers and characters. You can also load a logo in a paragraph and then format it using the Attributes

menu. See [Loading Logos](#) on page 1934. If you create text formats that you plan to reuse, save them using the Styles menu. See [Defining Styles](#) on page 1947.

Fill		100%	Soft 0.0
Underline		100%	Width 50.0
Outline		100%	Width 1.0
Back		100%	
Shadow		100%	Soft 0.0
Blur	5	X 5.00	Y -5.00

The Attributes controls are described as follows.

Fill button Sets fill colour, transparency, and softness. Set fill softness using the Soft field. To increase the softness, enter a value close to the maximum of 100. To decrease the softness, enter a value close to the minimum of -100. Enter 0 for no softness.

Underline button Underlines the characters using the associated colour, transparency, and width. Click the colour pot to choose a colour from the colour picker. To set underline transparency, enter a percentage in the Transparency field. To make the underline more opaque, enter a value close to the maximum of 100. To make the underline more transparent, enter a value close to the minimum of 0. To set the outline width, enter a value in the Width field.

Outline button Outlines the characters with a solid colour using the associated colour, transparency, and width. Click the colour pot to choose a colour from the colour picker. To set outline transparency, enter a percentage in the Transparency field. To make the outline more opaque, enter a value close to the maximum of 100. To make the outline more transparent, enter a value close to the minimum of 0.

To set the outline width, enter a value in the Width field. Use anti-aliasing rendering options with outlined text. These options are found in the Text Setup menu. See [Processing Text](#) on page 1913.

Back button Applies a solid colour background using the associated text layer colour and transparency. Click the colour pot to choose a colour from the colour picker. To set back transparency, enter a percentage in the Transparency field. To make the back more opaque, enter a value close to the maximum of 100. To make the back more transparent, enter a value close to the minimum of 0.

Shadow button Applies a shadow to text characters using the associated colour, softness, transparency, and Pos X and Pos Y fields. Click the colour pot to choose a colour from the colour picker. To set shadow transparency, enter a percentage in the Transparency field. To make the shadow more opaque, enter a value close to the maximum of 100. To make the shadow more transparent, enter a value close to the minimum of 0. To set shadow softness, use the Soft field. To increase the softness, enter a value close to the maximum of 100. Enter 0 for no softness.

To set the shadow position on the X-axis, enter a value in the X field. A positive value places the shadow to the right and behind the text characters. A negative value places the shadow to the left and in front of the text characters. To set the shadow position on the Y-axis, enter a value in the Y field. A positive value moves the shadow up. A negative value moves the shadow down.

Blur Shadow button Applies a blur effect to a drop shadow created with the Shadow button. The type of blur applied depends on whether Box Blur or Gaussian Blur is selected in the Text Setup menu. Choose a higher value for a greater shadow blur effect. Using Blur Shadow with animated text decreases processing performance.

These text attributes have a cumulative effect on the selected characters. For example, if you enable the Fill and Outline buttons, the text appears as solid characters with a coloured outline.

Modifying Layer and Character Properties

Use the Layer controls in the Axis menu to rotate, translate, scale, or shear a selected layer and to apply an effect uniformly to all characters.

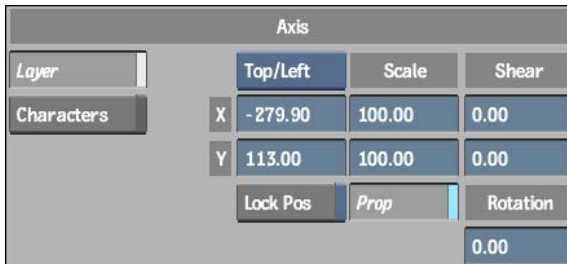

Use the Character controls in the Axis menu to view and position the axis of each character. You can use the position, rotation, scale, and shear settings for each character in a layer to create an effect of scrambled letters.

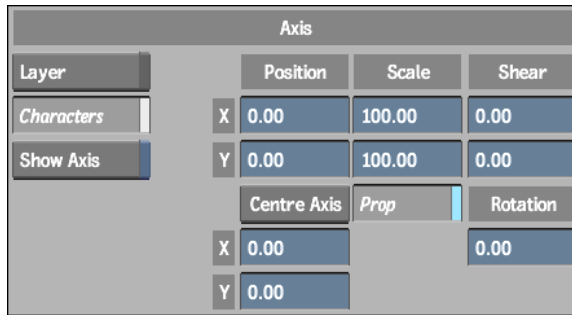

To edit text characters, you must be in Move or Edit mode and some text must be selected. The Layer and Character controls are described as follows.

Layer Axis box Sets the alignment for the selected text layer.

Select:	To move the axis:
Top/Left	To the upper-left corner of the text layer.
Centre	To the centre point of the text layer.

Pos X Moves the layer or selected characters along the X-axis. By default, the value is 0 (for characters). Increase the value to move right and decrease it to move left.

Pos Y Moves the layer or selected characters along the Y-axis. By default, the value is 0 (for characters). Increase the value to move up and decrease it to move down.

Scale X Scales the layer or selected characters along the X-axis. This value is a percentage, so entering 50 means 50 percent. Use a larger value to increase the scale along the X-axis. Use a negative value to create a mirror image on the X-axis. Enter 0 to make a layer or selected characters disappear. The default is 100.

Scale Y Scales the layer or selected characters along the Y-axis. This value is a percentage, so entering 50 means 50 percent. Use a larger value to increase the scale along the Y-axis. Use a negative value to create a mirror image on the Y-axis. Enter 0 to make the layer or selected characters disappear. The default is 100.

Prop Proportionally changes the Scale X and Scale Y values.

Shear X Shears or slants the layer or selected characters along the X-axis. Use a positive value to slant right and a negative value to slant left. The

maximum and minimum values are 60 and -60, respectively. The default is 0.

Shear Y Shears or slants the layer or selected characters along the Y-axis. Use a positive value to shear up. A negative value near the minimum value -60 shears down. The maximum and minimum values are 60 and -60, respectively. The default is 0.

Rotation Rotates a layer around its axis or selected characters around their axes. Use a negative value to rotate clockwise and a positive value to rotate counter-clockwise. The default is 0.

Lock Pos Locks a layer in a specified position. You can lock text in either the Top/Left or Centre position using the box beside this button.

Show Axis button Shows the axis in the image window.

Centre Axis button Moves the axis to the centre point of the character.

Character Axis Pos X and Y fields Sets the X- and Y-axes for the selected characters. Using the Axis Pos X and Axis Pos Y fields, you set each letter in a word spinning on its own axis in a different way.

Layer Order box (in the Layer Attributes section) Moves a layer in front of or behind another layer.



Select:	To move the layer:
Push	One position down in the stack behind another layer.
Pop	One position up in the stack in front of another layer.
Bottom	To the bottom of the stack behind all other layers.
Top	To the top of the stack in front of all other layers.

Aligning Layers

Use Align Sel mode to align multiple layers and specify the direction for the alignment.

To align text layers:

- 1 In the image window, select two or more layers to be aligned. To select multiple layers, **Ctrl**-click the layers (or click the pen button).
- 2 In the Text Mode box, select Align Sel (or press **Alt+J**).
- 3 On the numeric keypad, press the number that corresponds with the direction in which you want to align the selected layers.

Press:	To:
4	Align left.
6	Align right.
8	Align to the top.
2	Align to the bottom.
5	Centre align.

The text mode returns to Move when the Align Sel operation is done.

Adjusting Text Leading

Use Leading mode to adjust the spacing between lines of text in a paragraph. The selected lines are adjusted in proportion to the leading values already specified. Use this mode to adjust the leading among paragraphs with various leading values.

Rekerning Text

Kerning refers to the space between characters that you can either increase or decrease. Use Rekern mode to change the kerning of all selected characters in relative proportion to the current kerning values.

Use Rekern to adjust the kerning among paragraphs with various kerning values.

To rekern text:

- 1 Select the string of characters you want to rekern.
- 2 In the Text Mode box, select Rekern (or press **Alt+K**).
In the Paragraph menu, the Kern field changes to the Rekern field.

- 3 Enter a new value in the Rekern field or use the **up** and **down arrow** keys to rekern the text in single increments. Press **Shift+up arrow** or **Shift+down arrow** to rekern in increments of 10 pixels.

Resizing Text

Use Resize mode to change the font size of all the characters in a selection in relative proportion to the current font sizes. Use this mode if you have several font sizes represented in a selection.

The Size field allows you to apply an absolute font size value to selected text.

To resize text:

- 1 Select the string of characters you want to resize.
- 2 In the Text Mode box, select Resize (or press **Alt+S**).
The Size field you used to specify the original size of the text changes to the Resize field.
- 3 Enter a new value in the Resize field or use the **up** and **down arrow** keys to resize the text in single increments. Press **Shift+up arrow** or **Shift+down arrow** to resize in increments of 10.

Offsetting Text Layers

Use Y Offset mode to shift selected layers along the vertical axis—the Y-axis. Use the **up** and **down arrow** keys to offset the selection.

Using Safe Title

Use Safe Title mode to align selected text within the safe title overlay. Use the numeric keypad (0-9) to specify the direction of alignment. Safe title is used to define the boundary for positioning text and how it appears in a rendered clip. By default, new layers appear in the upper-left corner of the safe title area.

To align to the safe title:

- 1 Select the layer you want to align with the safe title.
- 2 In the Text Mode box, select Safe Title (or press **Alt+Z**).
- 3 Press the number on the numeric keypad that corresponds with the direction in which you want to align the selected layers. Press **1**, **2**, **3**, **4**, **6**, **7**, **8**, or **9** to determine the direction in which to align; press **5** to align

the layer in the centre of the safe title area. Press **0** to align the layer horizontally in the safe title area.

Copying and Pasting Character Channels

You can copy character attributes, transformations, or both, from one character and paste them onto a selection of others.

To copy and paste character channels:

- 1 Select the text from which you want to copy the attributes or transformations.
- 2 In the Character Channels section of the Text menu, click Copy Attributes, Copy Transformations, or Copy All.

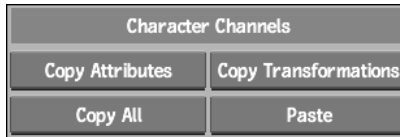

- 3 Select the text to which you want to paste the attributes or transformations.
- 4 Click Paste.

Grouping Text Layers

You can group two or more layers together to create a montage of text and move text layers together. Grouped layers can be saved and loaded as one unit. You can add more text layers to an existing group, resulting in a new single group.

NOTE When a group of layers is selected, you cannot switch to Edit mode.

To create a text layer group:

- 1 In the Text menu, select Move from the Edit Mode box.
- 2 **Ctrl-click** (or click the pen button) to select two or more text layers, or click Select All to select all text layers in the scene.

- 3 In the Layer Attributes section, enable Group.



Loading Logos

You load logos from the Desktop. You can use a logo so that it appears on every frame in a clip. Also, you can use logos in text rolls to credit sponsors, contributors, and products. Place a logo directly in a paragraph and then set text formatting properties for the logo.

Logos can be in a variety of formats, which are available when you choose Import Image in the Library menu. See [Importing and Soft-Importing Image Files](#) on page 210.

To insert a logo in a paragraph:

- 1 In the layer Attributes section, click Load Logo.



The Desktop appears.

- 2 Select a front clip, and optionally, a matte clip for the logo.
The logo is inserted at the cursor position in the text layer.
- 3 In the Font and Paragraph menus, increase or decrease the size of the logo in the text layer by adjusting the font size, leading, and kerning. See [Entering Text](#) on page 1922.

To save a logo:

- 1 Select the logos you want to save.
You can select and save multiple logos.
- 2 Click Save.
- 3 From the Save box, select Selected Logos.

- 4 Use the File field to name the logo.
- 5 Click Save.
The logo is saved as a *.tif* file.

Tabulating Text

You can organize text into columns by setting tabs in the Tabulation menu. In a text layer, you can also set tab stops to align text at specific locations in a paragraph.

To access the Tabulation menu:

- 1 Create a text layer.
- 2 In the Text menu, click Tabulation.

The Tabulation menu appears.



The Tabulation controls are described as follows.

Add Adds a tab stop on the text layer ruler. By default, tab stops are set at every 100 pixels.

Delete Removes the selected tab stop.

Previous Selects the previous tab stop on the text ruler. Tab stops appear in yellow when selected.

Next Selects the next tab stop on the text ruler.

Tab ID Verifies the tab number in the current paragraph. When you click Next or Previous, the Tab ID field changes, showing the number of selected tab stops.

Position Sets the exact tab stop position on the X-axis. This value is set in pixels.

Ruler Displays or turns off the tabulation ruler in the text layer.

Justification Selects Left, Right, or Centre text alignment at the tab stop.

To set a tab stop:

- 1 In the Tabulation menu, click Add to add the tab stop in a text layer.

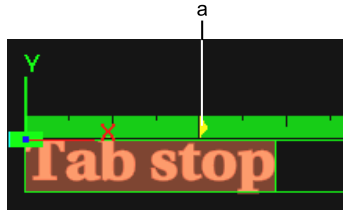

(a) Tab stop shown in the ruler

- 2 Click the tab stop and drag it to its new location on the ruler. Alternatively, enter a pixel value in the Position field.

Once you set tab stops for a paragraph, press **Tab** in subsequent paragraphs to type text in the location of the next tab stop. In a text layer, each time you press **Enter**, the tab stops you set in the previous paragraph are carried to the next paragraph.

Spell Checking

In the Spell Check menu, you can check the spelling of the text in a text layer. When spelling errors are encountered, a red line is drawn through words not in its dictionary. By default, the spell checker uses the language and dictionary installed with the operating system to verify the spelling of words. You can also create your own custom dictionary.

NOTE If the spell checker is not installed on your system, the Spell Check menu controls are disabled.

To access the Spell Check menu:

- 1 In the Text menu, click Spell Check.
The Spell Check menu appears.

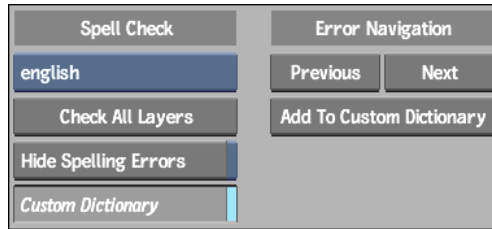

The Spell Check controls are described as follows.

Language Selects the language the spell checker should use.

Check All Layers Runs the spell checker on the text layers. When the spell checker encounters a misspelled word, it draws a red line through it.

Hide Spelling Errors Hides the red strike through the line that appears in each misspelled word.

Custom Dictionary Uses your custom dictionary with the spell checker. Disable this button to check all spelling.

Previous and Next Navigates to the next or previous misspelled word.

Add To Custom Dictionary Adds a word that the spell checker has deemed misspelled to the custom dictionary. The next time the spell checker encounters this word, it will be ignored.

To spell check a text layer:

- 1 In the Text menu, click Spell Check.
- 2 Enable Check All Layers.
Lines appear through misspelled words.
- 3 To correct misspellings, in Edit mode, click Next or Previous to navigate to each misspelled word.

Creating Text Rolls and Text Crawls

You can create text rolls, which are commonly used for credit rolls. A text roll is a layer of text that rolls from the bottom to the top of a clip for a series of frames. In a text roll, you can use special fonts as well as coloured, animated, and tabulated text.

You can include logos of sponsors, contributors, and products in text rolls. For example, you can create a list of credits that uses a green, sheared font for all contributors' names and includes a single, larger capitalized letter spinning on an axis at the beginning of each title line. The contributors' names can appear in a white, semi-transparent, Courier-type font.

A text crawl scrolls text horizontally across the frame. For example, you can create a list of phone numbers that scroll from left to right across the bottom of the screen during a telethon broadcast.

To access the Roll/Crawl menu:

- 1 In the Text menu, click Roll/Crawl.

The Roll/Crawl menu appears.

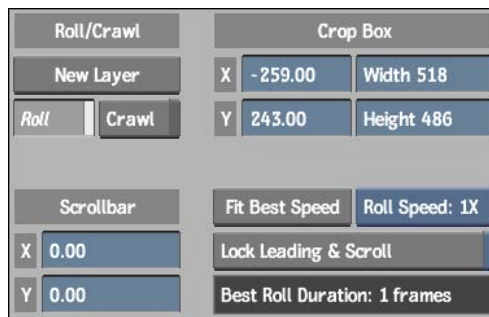

The Roll/Crawl controls are described as follows.

New Layer button Creates a layer to contain a text roll or text crawl.

Roll button Creates text that scrolls vertically over an image.

Crawl button Creates text that scrolls horizontally across an image.

Scrollbar X and Y fields Position the roll layer inside the crop box. These X and Y fields change value when you move the scrollbar at the right of the text layer for a roll or at the bottom of the layer for a crawl.

Crop Box X and Y fields Position the crop box inside the image window. The crop box determines the X and Y coordinates of the text roll or text crawl on the clip.

Width and Height fields Specify the height and width at which to crop the text within the text roll or crawl layer.

Fit Best Speed button Creates a broadcast quality text roll based on the number of frames in the clip and the lines of text in the text roll. Enable this

button to make corrections to a text roll without altering the speed or duration of the clip.

For NTSC and PAL, broadcast quality is calibrated at four pixels per frame. This rate ensures no flicker in the text roll.

Roll Speed button Changes the speed of the text roll. For 1X, the speed rate is 120 p/s (pixels/second) in NTSC, and 100 p/s in PAL. For 2X, it is 240 p/s in NTSC, and 200 p/s in PAL, and so on.

Lock Leading & Scroll button Locks the leading of the paragraph text so that you can insert another paragraph into the text roll. If the duration of the clip lengthens after you make modifications, click Fit Best Speed to adjust the length.

Best Roll Duration Displays the suggested duration for the text roll. The duration is calculated using the start/end position of the roll and the currently selected speed.

To create a text roll or crawl:

- 1 In the Text Setup menu Rendering section, enable PreRender, and then select Interlaced from the Render box.

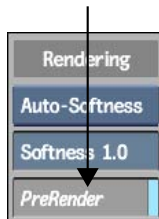

- 2 In the Text menu, select Interlaced from the Render box.
- 3 Enable Auto Key.
- 4 Click Roll/Crawl to enter the Roll/Crawl menu.
- 5 Go to the first frame of the clip, and enable Roll or Crawl.

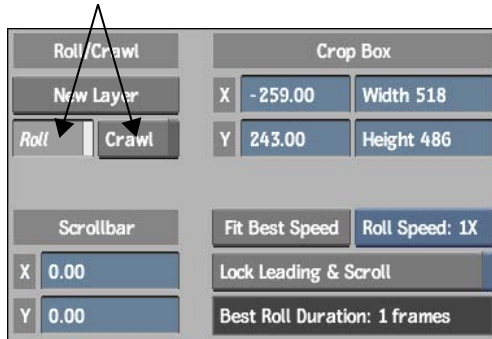

- Click New Layer and add the text you want to use for the text roll or crawl.

A shaded layer appears in the image window with a vertical scrollbar for a roll or a horizontal scrollbar for a crawl. The shaded area represents the crop box area. The following is an example of a text roll.

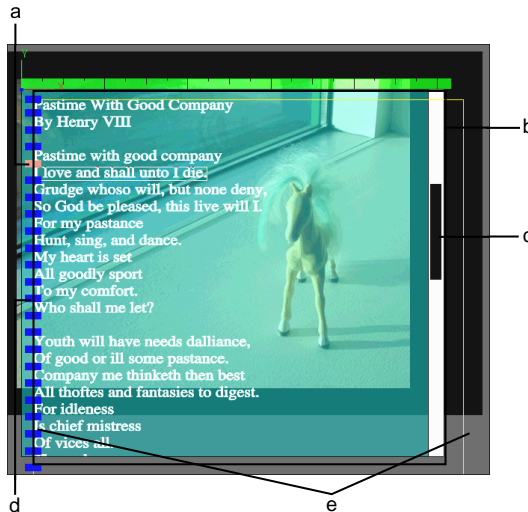

(a) Red indicates currently selected paragraph (b) Crop box (c) Scrollbar (d) Blue indicates paragraphs in text roll layer (e) Yellow border delimits text

- To set the start position of where the text appears in the text roll or crawl, use the Scrollbar X and Y fields or drag the scrollbar up or down (roll), or left or right (crawl).

- 8 Go to the frame where you want the text roll or crawl to finish and set the end position by dragging the scrollbar or using the Scrollbar X and Y fields.
- 9 If you want Flame to calculate the ideal number of frames for the text roll, choose a roll speed: 1X, 2X, 3X, or 4X.
The suggested duration appears in the Best Roll Duration field. You can either change the number of frames in your clip to match the one in the Best Roll Duration field, or you can leave the clip as is.
- 10 If the suggested duration is acceptable, enter it in the Duration field and then click Fit Best Speed.
The roll is created and the Scrollbar position and Leading are changed (if required) and locked.
- 11 If the suggested duration is not acceptable, click Fit Best Speed.
The roll is created and the Scrollbar position and Leading are changed (if required) and locked.
- 12 Click Process to render the text roll and view the results.
When you play the clip, the text rolls or crawls through the image area from the first position to the final position.

NOTE When processing text rolls and crawls, use PreRender in the Text Setup menu to render the roll or crawl relatively fast while bypassing the animation. Check the message bar to see whether PreRender is enabled.

Animating Text

You can animate text properties including colour, softness, size, shadow, and transformation effects such as rotation, scale, and shear. For example, you can animate text channels to create an effect where the text appears gradually over time and then disappears from view.

Use Auto Key to create keyframes automatically as you make changes to text attributes. The movement between keyframes is interpolated according to the interpolation mode you set.

NOTE PreRender must be disabled when creating text animations. See [Processing Considerations](#) on page 1918. Check the message bar to verify the PreRender status.

To animate text automatically:

- 1 In the Text Animation menu, enable Auto Key.

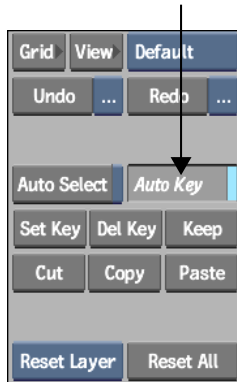

- 2 Go to the first frame in the clip.
- 3 With the Attribute controls, set the attributes and transformation properties.
- 4 Navigate to another frame in the clip and add more attributes and transformation properties according to the effect you want to produce.
- 5 Click Preview.
- 6 Make modifications as required and when finished, click Process.
- 7 Click Play to view the result.

When you play the clip, the animation moves from the first frame to the last.

Animating Paragraph Channels

In the Text module, the Animation controls include a Paragraph Channel View for viewing text channels in the Channel Editor. Use the attributes and transformation channels to animate paragraphs and characters and fine-tune animations created using the Attributes menu.

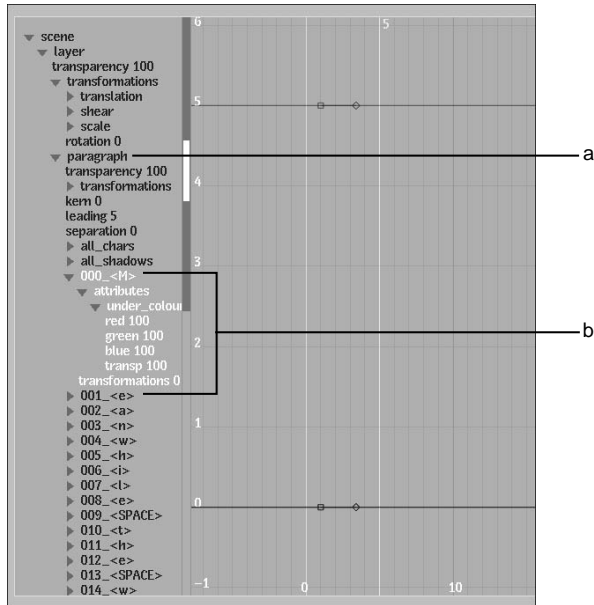

(a) Paragraph folder contains all the characters, including spaces between words (b) You can animate specific channels for each character

To animate paragraph channels:

- 1 In the Text menu, click Animation to display the Channel Editor.
- 2 From the Paragraph Channel View box, select the paragraph channels you want to view in the Channel Editor.



Select:	To view:
Current	The channels for the selected paragraph—the current cursor location.
Layer	The channels for all paragraphs in the selected layer.
All	All channels for all paragraphs in all layers.

- 3 Animate the selected channels as required. See [Creating Animations](#) on page 1971.

Animating Text on a Motion Path

You can create a text layer on a spline and animate it over time. In this way, you create marquee text that twists and turns over an image or in time with other objects in the scene. The spline is fully editable; you can add control points and manipulate their tangent handles. In the Channel Editor, the Path group contains a Shape channel for the path and an Offset channel for the offset value.

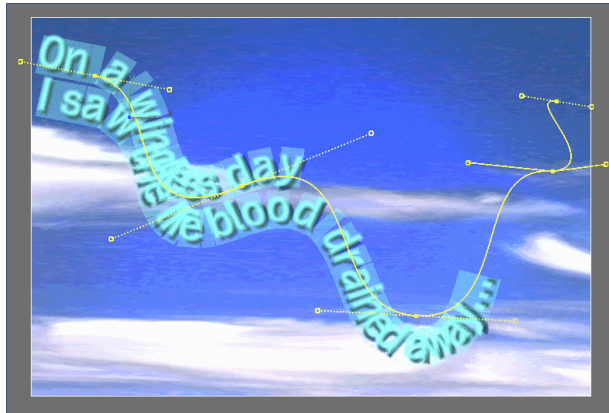

You can set custom colours for the text path wireframe and vertices in the Text Setup menu. See [Processing Text](#) on page 1913.

To animate text on a motion path:

- 1 Create a layer or select a layer in the image window.
- 2 From the Text On Path section of the Text menu, enable On Path.



By default, the text appears on a path with three vertices.

- 3 Adjust and animate the shape of the path using the Text On Path controls.

The Text On Path controls are described as follows.

On Path button Places text on a motion path.

Closed button Closes the path by connecting the first and last vertices. Text will continue around the shape.

Offset field Sets the position of the text on the path. Animate the Offset value to make the text follow the path for the duration of the clip.

Invert button Reverses the order of the vertices on the path so that the text follows the opposite side of the path.

Text On Path Mode box Provides settings for manipulating the spline.

Select:	To:
Move	Modify the shape of the spline by changing the position of the vertex or tangent.
Add	Add more vertices to the spline to create a more complex shape with text. Click anywhere on the path to add a vertex.
Delete	Remove a vertex from the spline.
Break	Separate two tangent handles and move them independently. Click a tangent; the tangent handle changes from a dashed to a solid line to indicate it is broken.
Auto	Connect broken tangents automatically. Click a tangent to reconnect it.

Clear button Resets the text path at the current frame. To reset the path for the entire duration of the clip, click Reset Layer.

Saving and Loading Path Setups

You can use a garbage mask spline as a shape for the motion path of text on a path. You can save and load the Shape channel as a list in raw shape data (.raw file), which is compatible with garbage mask raw data. Raw setups between text paths and garbage masks are interchangeable.

To load a raw shape data file:

- 1 In the Text On Path controls, enable On Path.
- 2 Click Load.
The Text load options and file browser appear.
- 3 In the file browser, select Path and then select Default from the Text Path loading boxes.

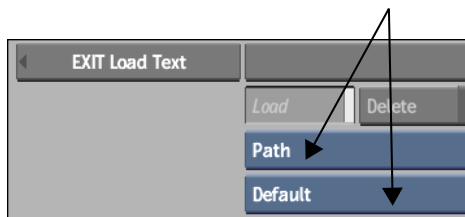

A set of path files is visible when the Path and Default options are selected in the Load Text menu.

- 4 Browse to find the file you want to load.

TIP Gmask setup files are typically located in the `/usr/discreet/<product home>/path/default` directory.

- 5 Click Load.

The spline appears with its new shape in the image area.



Defining Styles

Styles are sets of text attributes and specifications that can be replicated when you need to use the same format again. You create and modify styles, and save and load them from the file browser using the Styles menu. The following character attributes are saved with the style: font, colour, outline, shadow, blur, scaling, rotation and shear. In addition, the layer's background colour and opacity are saved as well.

To access the Styles menu, click the Styles button in the Text menu.



(a) Style Mode box (b) Style Option box

To define a style:

- 1 Select a character with the attributes you want to save.
You can select multiple characters, but it is the first one that defines the style.
- 2 From the Style Option box, select Define Style and then click the style button to which you want to assign the style.
- 3 Click Name and enter a name for the style. Then click the style button to which you want the name to apply.
The new name appears on the button.

NOTE You can use **Ctrl+Shift** and **F1** to **F9** to assign text attributes to Style buttons 1 through 9 from any menu.

To modify a style:

- 1 Select the character with the attributes you want to save.
- 2 From the Style Option box, select Define Style and then click the style button to which you want to assign the style.

NOTE You can use **Ctrl+Shift** and **F1** to **F9** to assign a style to Style buttons 1 through 9 from any menu.

To clear a style:

- 1 From the Style Option box, select Clear Style and then click a style button.

NOTE It is sometimes convenient to clear all styles just prior to using AutoStyle to save multiple styles automatically. AutoStyle assigns up to nine style buttons at once. See [Saving Multiple Styles Automatically](#) on page 1950.

To apply a style:

- 1 Select a paragraph or string of characters to which you want to apply a style.
- 2 Press **Ctrl+F1** to **F9**, or press the style button, to apply the style to the selected text.

Saving and Loading Styles

After you create styles, you may want to save one or all of them. You can load any of them in future sessions.

To save a style:

- 1 Do one of the following in the Styles menu:
 - Select All Styles from the Style Mode box.
 - Select One Style from the Style Mode box, and the style you want to save (Style 1 to Style 9).
- 2 Click Save Style.
The Save Styles menu and file browser appear.
- 3 Choose a directory for the style.

NOTE You can click the Create Dir button to create a new directory in which to save your styles.

- 4 Enter the filename.
The style is saved. The file browser automatically closes and the Styles menu reappears.

To load a style:

- 1 Select an option from the Style Mode box.

Select:	To:
All Styles	Load files saved with multiple styles. The file browser lists setups saved with multiple styles.
One Style	Load files saved with one style only. The file browser lists setups saved with a single style.

- 2 Click Load Style.
The Load Styles menu and file browser appear.
- 3 Navigate to the appropriate directory and select the style(s) you want to load.
- 4 If necessary, click Exit Load Text to exit the file browser.

Saving Multiple Styles Automatically

If you create a section of text with multiple sets of attributes, you can assign each set as a separate style with a shortcut and then save them. The Text module automatically detects the different sets of attributes used in the section and assigns each set to a Style button. You can then use shortcuts to apply them.

To assign styles from an existing layer using shortcuts:

- 1 Select the section of text.
- 2 From the Style Option box, select AutoStyle.

NOTE If you used more than nine sets of attributes in the selection, only the first nine are assigned to a Style button.

- 3 Save the styles.

Changing Fonts

When you open the Text module, the default font is loaded and ready to use. When you choose a different font, it becomes the current font and all text

you type appears in the current font. If you edit text that has a different font, the current font is replaced by the font of the text at the cursor position. For example, if you are working with Carta font and you edit text that uses Helvetica, Helvetica becomes the current font and all subsequent text you type appears in Helvetica.

You specify the default font using the TextDefaultFont token in the *init.cfg* configuration file. See the *Autodesk Visual Effects and Finishing Configuration File Reference Guide*. Also, you can install additional fonts for use in the Text module. See [Installing Fonts](#) on page 873.

To change the current font:

- 1 In the Font section of the Text menu, click the Font field.

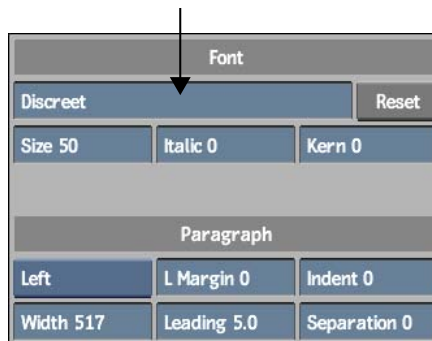

The font library appears.

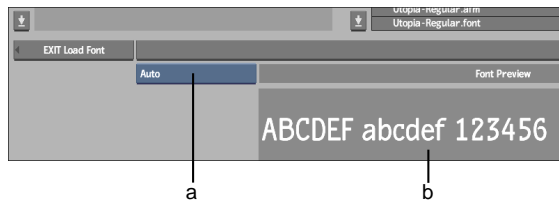

(a) Font Type box (b) Font Preview window

- 2 In the Font Type box, select the font type you want to load.

Type	Description
Type 1	A single-byte font type designed for Roman language fonts. Soft-links to the Adobe Postscript® Type 1 fonts installed with the system or supplied by Autodesk are contained in <i>/usr/discreet/font</i> directory.

Type	Description
CID	A multi-byte adaptation of Adobe Postscript Type 1 fonts, well-suited to representing the large character sets of Asian languages such as Japanese, Korean and Chinese.
TrueType	A widely used cross-platform font format.
Open-Type	A font developed by Adobe and Microsoft® that supports expanded character sets and layouts.
Auto	Displays all font types, detecting the type automatically.

- 3 In the file browser, navigate to the directory that contains the font you want to load.
- 4 Preview a font. Do one of the following:
 - Select a font to see it with sample text in the Font Preview window. The sample text can be the text you selected in the text layer, or text that you enter by clicking the Font Preview window to display the on-screen keyboard.
 - In the Proxies/Titles box, select Proxies to preview fonts. If no proxy appears, click Generate Proxies to generate a font proxy. This process may take a while, but once you create the proxies, the settings are retained. Each time you return to the font library, you can toggle between viewing font titles and font proxies by selecting Proxies or Titles.
- 5 Select the font.
- 6 Click Load.
The Text menu reappears with the name of the new font in the Font field.

Pasting Text from an External Source

You can copy text from a Linux terminal or another application and paste it directly in a text layer.

To paste text from a terminal to the Text module:

- 1 In the Text module, create a layer for the text you want to paste.

- 2 Click the Font field and select a non-Latin font.

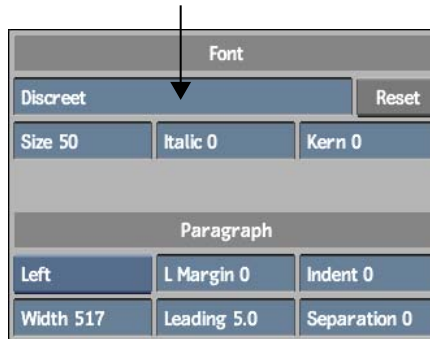

NOTE A non-Latin font must be selected to display the non-Latin characters.

- 3 In the terminal, copy text including non-Latin text.
- 4 In the Text module, paste the text in a text layer.

NOTE Non-Latin characters do not appear in the Channel Editor—the generic <CHAR> name appears instead.

Entering Non-Latin Text

When entering non-Latin text characters make sure the required *kinput2*, *canna*, and *Wnm6* packages are installed.

The following example illustrates entering Japanese text in a text layer.

To enter Japanese text in a text layer:

- 1 Start the canna daemon by typing `/etc/init.d/canna start` in a Linux terminal.
- 2 Type the following commands in the terminal:
 - `kinput2 -canna &`
 - `setenv XMODIFIERS @im=kinput2`
 - `setenv LANG ja_JP.eucJP`

NOTE For detailed instructions on kinput, canna, and Wnn6, consult your system documentation.

3 Start your Autodesk application.

4 Load a clip in the Text module.

Notice the message bar that appears at the top of the screen. This indicates you are in Latin input mode.

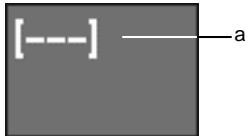

(a) Message bar

5 Create a layer and click the Font field to select a Japanese font from the file browser. From the Text Mode box, select Edit and then select the layer in the image window.

When you type text, notice that you are still in Latin input mode.

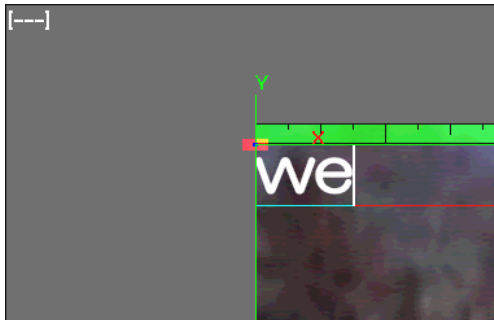

6 Press your Input Method hot key.

The message bar changes to indicate that you are in Japanese text mode.



(a) Message bar

- 7 Type text, as required.
- 8 Press **Enter** to accept the characters and add them to the text layer.

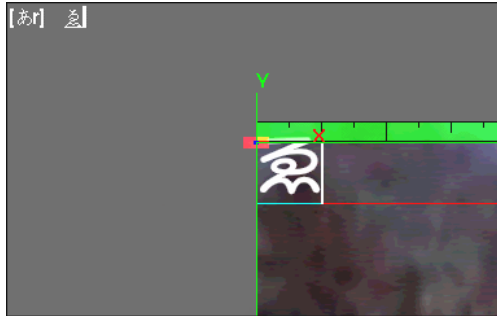

- 9 To revert back to Latin input mode, press the Input Method hot key again.

Topics in this chapter:

- [About Sparks](#) on page 1957
- [Loading a Sparks Plug-in](#) on page 1957
- [Replacing a Sparks Plug-in](#) on page 1958
- [Using a Sparks Plug-in](#) on page 1959
- [Developing Sparks](#) on page 1960

About Sparks

Sparks are software plug-ins created by Autodesk or third-party developers.

You can load and use Sparks from the Effects menu or in Batch.

Because specific procedures for using Sparks are as varied as the Sparks themselves, only general information is provided here.

Loading a Sparks Plug-in

On the desktop, you can load up to five Sparks at one time. When loading Sparks through Batch, you can load any number of Sparks. See [Spark Node](#) on page 1372.

To load a Sparks plug-in on the desktop:

- 1 From the Main menu, click Effects.
- 2 From the Effects menu, click one of the Sparks buttons. An L on the button indicates that you can load a Sparks plug-in.



The file browser appears.

- 3 Navigate to *usr/discreet/sparks*.
You can also load Sparks from *usr/discreet/<product home>/sparks*.
- 4 Select a Sparks plug-in.
You are returned to the Effects menu and the name of the Sparks plug-in appears on the selected button. The L no longer appears on the button.
- 5 To exit the file browser without loading a plug-in, click EXIT Sparks Browser.

Replacing a Sparks Plug-in

If you want to load a new Sparks plug-in but all the Sparks buttons are already in use, you can replace an existing Sparks plug-in with the new one.

To replace an existing Sparks plug-in with a new one:

- 1 From the Main menu, click Effects.
- 2 Press **Alt** and click the existing Sparks button in the Effects menu.
The file browser appears.
- 3 Navigate to */usr/discreet/sparks* or */usr/discreet/<product home>/sparks* and select a Sparks plug-in.
You are returned to the Effects menu, and the name of the new Sparks plug-in appears on the selected button.

Using a Sparks Plug-in

A Sparks plug-in functions in the same way as other commands or modules. Some Sparks are designed to be used on the Desktop or as a module.

To use a Sparks plug-in on the Desktop:

- 1 In the Effects menu, click a loaded Sparks button.
The Sparks controls, if any, appear.

		Initial Pivot X: 0.00
SparkWipe	Delete	Final Pivot X: 0.00
Sparks	L Name	Initial Pivot Y: 1.00
Sparks	L Move	Final Pivot Y: 0.00
Sparks	L Copy	Initial Angle: 0.00
Sparks	L Search	Final Angle: 0.00

- 2 Choose the processing modes and enter the parameter values as appropriate for the selected Sparks plug-in. These values are specific to each Sparks plug-in.
- 3 Select the source clips and the destination reel.
The processed clip appears in the destination reel.

To use a Sparks plug-in as a module:

- 1 In the Effects menu, click a loaded Sparks button.
- 2 Select the source clips.

When there is a module for a Sparks plug-in, an E appears on the button.

		Initial Pivot X: 0.00
SparkWipe	E Delete	Final Pivot X: 0.00
Sparks	L Name	Initial Pivot Y: 1.00
Sparks	L Move	Final Pivot Y: 0.00
Sparks	L Copy	Initial Angle: 0.00
Sparks	L Search	Final Angle: 0.00

(a) E on SparkWipe button

3 Click the E on the Sparks button.

4 Select a destination reel.

The Sparks module appears. Use the controls in the Sparks module as you would for other modules.

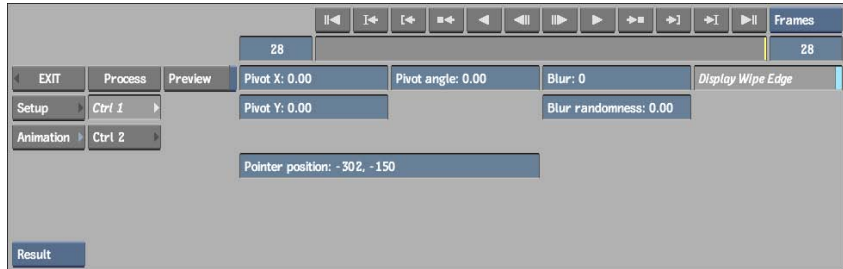

NOTE An S next to the Sparks button lets you enter the module using the same media from the previous session.

Developing Sparks

The *Autodesk Sparks API Reference Guide* is available in PDF format. If you are interested in marketing or selling your Sparks, you must apply to the system Sparks program. To request an application, send an e-mail message to sparks-manager@autodesk.com.

Part II: Animation and Expressions

Part II includes these chapters:

- [Animation](#) on page 1963
- [Expressions](#) on page 2039

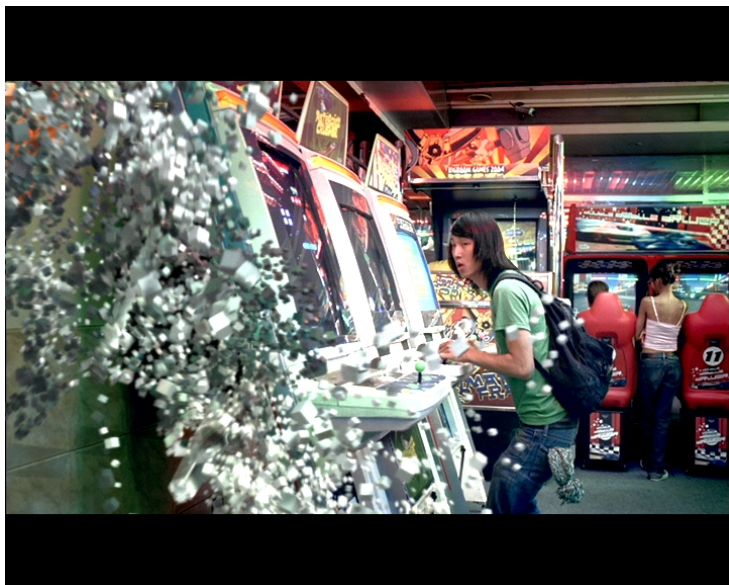

Image courtesy of Syndicate Ent. - Syndicate Technologies

Topics in this chapter:

- [About Animation](#) on page 1963
- [Accessing the Channel Editor](#) on page 1964
- [Creating Animations](#) on page 1971
- [Displaying Channels](#) on page 1985
- [Editing Keyframes](#) on page 2001
- [Controlling the Speed of Objects](#) on page 2022
- [Creating Animation Sequences Across Nodes in Batch](#) on page 2029

About Animation

Animation is based on a principle of human vision. If you view a series of related still images in quick succession, you perceive them as continuous motion. Each individual image is referred to as a frame. In Flame, *animation* refers to a value that changes over time. A value can be anything from the position, rotation, scaling, or transparency of an object, to the gamma, gain, or offset in a colour correction.

A common animation technique uses changes in position and orientation of objects on successive frames to create the illusion of movement. For example, in Action, you can set the position of objects, light sources, and cameras for an animated result.

There are several approaches to creating animations. To animate speed and position independently, use motion path animation. To animate object properties such as transparency and scaling, or material properties such as colour, blending, and textures, set keyframes automatically or manually. Most properties in Flame can be animated.

Values used to create animations are called *channels*. You set channel values in the Channel Editor. To create an animation, you set a different value for the same channel at two or more frames. After you set a value for a channel at a particular frame, the value at that frame is called a *keyframe*.

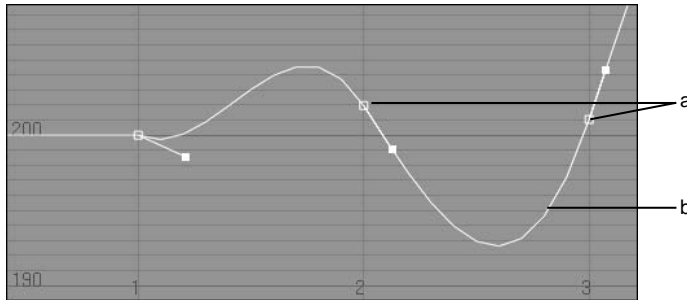

(a) Keyframes (b) Animation curve

Each keyframe has two components: a value for the channel and the frame where the value is set. Keyframes are plotted on an animation curve in the Channel Editor. This curve maps frame numbers on the horizontal axis and channel values on the vertical axis. When you set more than one keyframe, the values between the keyframes are automatically calculated, creating the animation curve.

Accessing the Channel Editor

You use the Channel Editor to create animations. Almost all Flame modules link directly to the Channel Editor. Its interface and functionality remain the same across all modules, while the specific animation channels correspond to the module itself as follows:

- **Action**—Channels include the position, rotation, scaling, surface, and texture of an object. For example, use the Channel Editor to animate the position and colour of a light source.
- **Paint**—Channels include the shape, scale, and rotation of geometry, as well as brush size.

- **Keyer**—Channels include matte transparency and position of a garbage mask.
- **Colour Corrector**—Channels include highlights, midtones, and shadows as well as hue, saturation, and contrast.
- **Batch**—Channels include all nodes present in the schematic. Through Batch you access the Universal Channel Editor, which allows you to control animation behavior and synchronize the timing of animations across different nodes.

The Channel Editor has three channel views, each of which is used to control and coordinate different aspects of your animation.

To access the Channel Editor:

- 1 Click Animation from the appropriate module.



- 2 From the Channel view box, select a view.



Select:	To display:
Channels	The Animation Curve window. Use the Animation Curve window to edit the animation curve, as well as the timing and values of the individual keyframes and tangents that compose each channel.
Tracks	The Track Editor. Use the Track Editor to edit the timing of the overall animation channel, as well as the timing of the individual keyframes that compose each channel.
Info	The Information Table. Use the Information Table to view the animation channels of your scene with corresponding values, along with applied expressions which you can work with, in a list.

These view options are also available from the View box in all modules. When you select Channels, Tracks, or Info from the View box, the image window (or current viewport) displays the selected view.

To view the Channel Editor in the image window, swipe the bar at the left or right side of the menu. Swipe the bar again to view the clip in the image window.

NOTE To change the view of the Channel Editor in Batch, swipe the right side (swiping the left side displays the node bin).

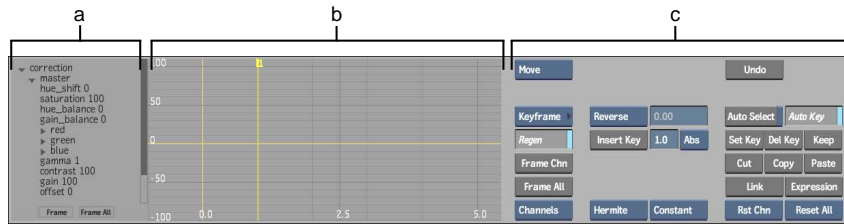

(a) Channel hierarchy (b) Animation Curve window (c) Animation controls

The Channel Editor includes the following components.

Channel hierarchy Organizes the channels of a particular module in a hierarchy of folders. The folders contain channels that are grouped based on the properties they animate.

When the channel hierarchy first appears, only the top-level folders are shown. You can expand these folders to set values for specific channels by clicking the arrow next to the folder name. For example, the Scale folder contains channels for scaling the object on the X and Y plane. Channels are indented and appear below their folders.

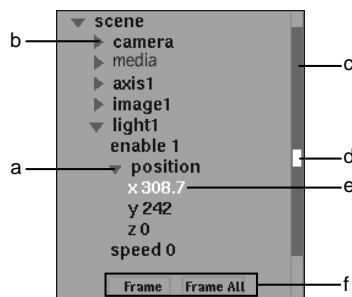

(a) Expanded Position folder (b) Camera folder (c) Scroll bar (d) Indicates the relative position (e) Value (f) Framing buttons

In the channel hierarchy, the value for the current frame is shown beside the channel name.

Animation controls Used to create and modify keyframes, filter the display of channels and keyframes, and create and modify animation expressions. There are common elements to the animation controls, as well as specific menus depending on what is selected in the Animation Controls box. See:

- [Editing Keyframes](#) on page 2001
- [Displaying Channels](#) on page 1985

■ [Expressions](#) on page 2039

Animation Curve window Plots keyframes on a curve and indicates the current keyframe position when you select the channel name. Selecting a complete channel highlights its curve and its name in the channel hierarchy in white. When you select a folder, the animation curves for all channels in the folder are highlighted. Partially selecting a channel (that is, not all keyframes are selected), highlights its curve and its name in the channel hierarchy in yellow. Unselected channels and keyframes are highlighted in black.

Keyframes turn white when selected and black when unselected. You can select keyframes from different channels to manipulate them.

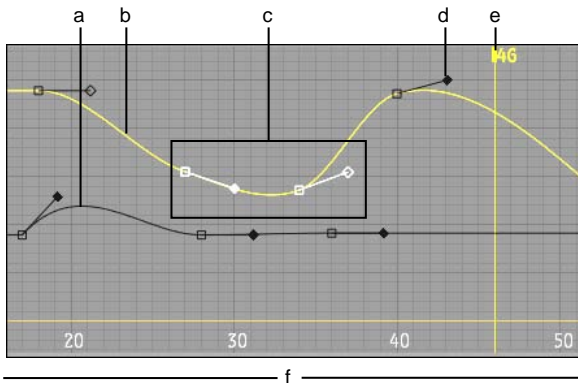

(a) Unselected channel (b) Partially selected channel (c) Selected keyframes (d) Tangent handle (e) Current frame (f) Frame number

The frame number in the animation is mapped along the horizontal axis, ranging from 0 at the origin to the total number of frames (shown in the Total Frames field) at the right. The vertical bar indicates the frame currently in the image window.

The channel value is mapped on the vertical axis, increasing upward and decreasing downward. The range depends on the portion of the curve being framed.

When you set a value for a channel at a particular frame, it becomes a keyframe in the animation. Keyframes on an animation curve with Hermite or Natural interpolation display tangents with which you can control the slope of the curve. See [Setting Interpolation](#) on page 1980.

Track Editor Displays keyframes along a horizontal bar and indicates the current keyframe position when you select a channel. You can change the

timing for keyframes or set new keyframes. However, you cannot change a keyframe's value or its tangency. For example, if a keyframe indicates a particular X position value for a light in Action, you can use the Track Editor to change the time at which the light will be located at this X value, but you must use the Animation Curve window, the channel hierarchy values, or the menu of the module, to change the X value itself.

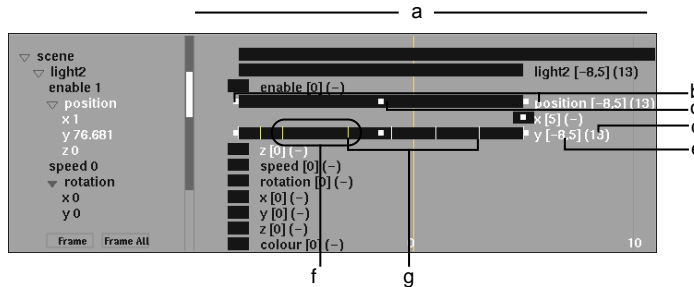

(a) Track duration (b) Left/right handles (c) Middle handle (d) Number of frames in track (e) First and last frames in track (f) Selected keyframes (g) Keyframes

The frame number in the animation is mapped along the horizontal axis, ranging from 0 at the origin to the total number of frames (shown in the Total Frames field) at the right. The vertical bar indicates the frame currently in the image window.

The position and length of a track is determined by the first and last keyframes for the channel it represents. The track extends from the frame number of the first keyframe to the frame number of the last keyframe. The frame numbers for the first and last keyframes appear to the right of the track and are shown in square brackets [1, 32], and the total number of frames is shown in parentheses (32). If a channel contains no keyframes, the number zero appears in square brackets [0] and a dash appears in parentheses (-) beside the track.

Selecting a channel also highlights its track. When you select a folder, the animation tracks for all channels in the folder are highlighted. Keyframes appear as white vertical lines intersecting the track, and turn yellow when selected.

When you select a track, three handles appear as white squares on the track. You use the middle handle to translate the track in time, and the left and right handles to scale the overall duration of the track.

Information Table Displays a table of channels present in the scene, sorted by channel value, keyframe, and expression. Viewing channels in a tabular format makes it easy to navigate the channel hierarchy and locate keyframe information. See [Viewing Channels in a Table](#) on page 1985.

In the Information Table, you can also see and work with expressions applied to tracks. See [Working with Expressions in the Channel Editor](#) on page 2043.

Channel	Component	Value	# Keys	Expression
○ ResultCamera	ResultCamera	0	0	
▶ camera	camera			
▶ media	media			
▶ axis 1	axis 1			
▼ 1 image1	image1			
○ 2 transparency	transparency	0.245446	3	
▶ 3 material	material			
▶ 4 offsets	offsets			

(a) Channel column heading (b) Selection order (c) Channel View box

Accessing Channel Views from Viewports

Any of the Channel Editor's views can also be displayed in a viewport.

In a multiple viewport setup, you can display multiple channel views simultaneously. Multiple viewports are available in the Colour Corrector, Action, Batch, the Modular Keyer, Distort, and Resize. See [Displaying Multiple Views](#) on page 136.

For example, in a 3-Up view, you can display your clip in one viewport, the Animation Curve window in another viewport, and the Track Editor in the third. This way, you can perform functions unique to a channel view, such as adjusting tangents in the Animation Curve window, while coordinating channels in time in the Track Editor, without having to constantly switch channel views.

To display channel views in a viewport:

- 1 Select a viewport.
The selected viewport's border turns yellow.
- 2 Do one of the following:
 - From the View box, select a channel view.

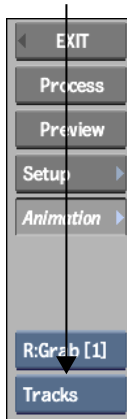

- Press **F5** to cycle through channel views.

NOTE Your edits in one animation view are immediately reflected in all channel views that are displayed.

Creating Animations

You can create many forms of animation in Flame. For instance, your animation can be as simple as a layer gradually floating across the screen or slowly fading out. In contrast, you can create a cartoon animation in Paint, then composite it as media in Action so that it uses motion paths and camera changes to add to the sense of movement.

Assess the composite and determine what layers and objects need to be animated for the result you want to achieve. If you are animating position and speed, determine whether you want the animation to follow a motion path. See [Creating a Motion Path](#) on page 2023.

Keyframe animation, in its simplest form, involves selecting something in a clip such as a layer or 3D object, setting its properties at one frame, moving to another frame, and changing these properties. The values between the keyframes are determined automatically using interpolation. The values before the first and after the last keyframes are determined automatically using extrapolation. Interpolation determines the rhythm of the animation between keyframes, while extrapolation determines the rhythm before and after the animation begins and ends. You can set the default interpolation and

extrapolation used when you animate channels. See [Setting Interpolation](#) on page 1980 and [Setting Extrapolation](#) on page 1983.

You can set keyframes automatically when you enter values for a channel in the Channel Editor, or you can set keyframes manually. Typically, it is easier and more efficient to set keyframes automatically, particularly when you position an axis or an object in the scene or when you want an effect that changes frequently over time. After setting several keyframes automatically, adjust some keyframes manually for a more precise effect.

Alternatively, you can use a more advanced technique by setting an object's position based on another's animated property setting using an expression. See [Expressions](#) on page 2039.

Setting Keyframes Automatically

The following procedure illustrates the animation workflow by describing how to set keyframes automatically for the saturation channel in the Colour Corrector. Subsequent procedures illustrate how to create animations in Paint and Action, respectively.

To animate saturation in the Colour Corrector:

- 1 In the Colour Corrector menu, enable Auto Key.

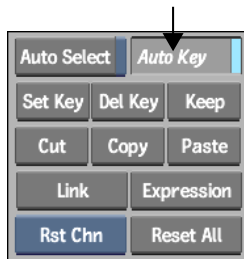

When Auto Key is enabled, a keyframe is set automatically each time you change a value at any frame.

- 2 In the timebar, position the clip at the first frame.
- 3 In the channel hierarchy, click ▼ beside the Master folder.

TIP Press **Alt** and click to expand the folder and all subfolders. When several folders are expanded at once, it can be hard to match animation curves with their corresponding channel in the channel hierarchy. Collapse folders you are not using to isolate the channel you want to edit by clicking . See [Displaying Channels](#) on page 1985.

- 4 Select the saturation channel and double-click the value.
- 5 Enter 200.
- 6 In the timebar, position the clip at frame 30.
- 7 In the Channel Editor, double-click saturation and enter 0.
The second keyframe is set. The channel name and curve are highlighted.

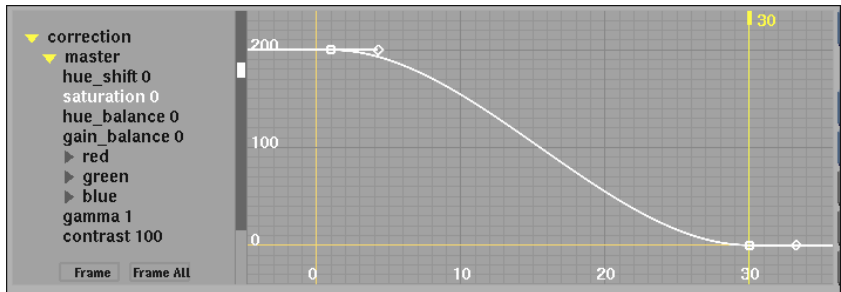

You have created an animation that reduces the saturation over 30 frames.

- 8 In the Animation controls, click Frame Chn.
The Frame Channel button adjusts the zoom factor in the Animation Curve window so that the selected curve is displayed completely. In this way, you can see the full shape of the curve from the first keyframe to the last keyframe.
- 9 Preview the result by clicking Process.
- 10 Modify values, animation curves, and interpolation to refine the animation until you are satisfied with the result. See [Editing Keyframes](#) on page 2001 and [Setting Interpolation](#) on page 1980.
- 11 If you are animating several channels in the Colour Corrector, you can adjust the timing of the animations. See [Controlling the Speed of Objects](#) on page 2022.
- 12 If you intend to create keying and compositing animations, save the current setup in the Colour Corrector and reload it later in Batch.

In Batch, use the Universal Channel Editor to synchronize animations among Colour Corrector, Keyer, Action, and other nodes. See [Synchronizing Animations](#) on page 2031.

To animate the size and colour of a brush stroke in Paint:

- 1 Click Paint, and then click AutoPaint.

The AutoPaint menu appears.

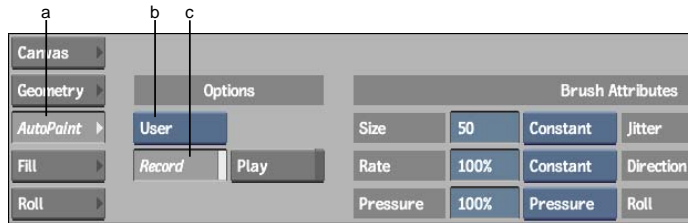

(a) AutoPaint button (b) AutoPaint Mode box (c) Record button

- 2 Set the following options:

- From the AutoPaint Mode box, select User. See [Using AutoPaint](#) on page 2457.
- Set brush attributes. See [Brush Attributes](#) on page 2428.

- 3 Enable Record.

The Record button records the brush strokes. See [Recording Brush Strokes](#) on page 2462.

- 4 Create brush strokes by painting on the clip.

Once you are finished recording the brush strokes, you are ready to animate the brush and brush stroke attributes.

- 5 Click below the timebar to stop recording.

Record is disabled and you are in Play mode.

- 6 Enable Animation.

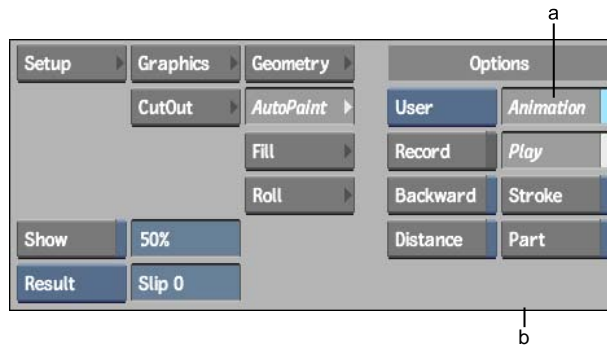

(a) Animation button (b) Swipe bar

- 7 Swipe the bar at the bottom of the Paint menu to display the Channel Editor.
- 8 In the animation menu, make sure that Auto Key is enabled.
- 9 Move the positioner to the first frame.
- 10 In the channel hierarchy, open the Brush folder and set the following channel values:
 - Set the Size channel to 1.
 - Set the Colour g (green) channel to 12.
- 11 Move the positioner to frame 7 and set the following channel values:
 - Set the Size channel to 50.
 - Set the Colour g (green) channel to 98.
- 12 Move the positioner to frame 11 and set the following channel values:
 - Set the Size channel to 66.
 - Set the Colour g (green) channel to 100.
 - Set the Colour b (blue) channel to 48.
- 13 Move the positioner to frame 30 and set the following channel values:
 - Set the Size channel to 118.
 - Set the Colour g (green) channel to 17.

- 14 Click Process and then play the clip to view the result of the animated brush stroke.

To animate the transparency of media in Action:

- 1 In Action, load a front, back, and matte clip.
- 2 Add a surface for the media.
- 3 In the Action menu, enable Auto Key.

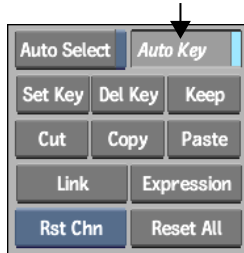

When Auto Key is enabled, a keyframe is set automatically each time you change a value at any frame.

- 4 Move the positioner to frame 1.
- 5 Click Object to display the Image menu.
- 6 Enter 0.0% in the Transparency field.
- 7 Move the positioner to frame 10 and set the transparency to 16%.
- 8 Move the positioner to frame 20 and set the transparency to 40%.
- 9 Move the positioner to frame 30 and set the transparency to 100%.
- 10 Click Animation and open the image x folder, where x is an integer representing the image.
- 11 Select the transparency channel.
Keyframe indicators appear as blue bars in the timebar.
- 12 Click Process and then play the clip to view the result of the animated media transparency.
- 13 If necessary, edit the timing of the keyframes in the Track Editor to make sure all of the different animations occur in proper sync. In a viewport, press **F5** until the Track Editor appears, or select Tracks from the Channel View box.

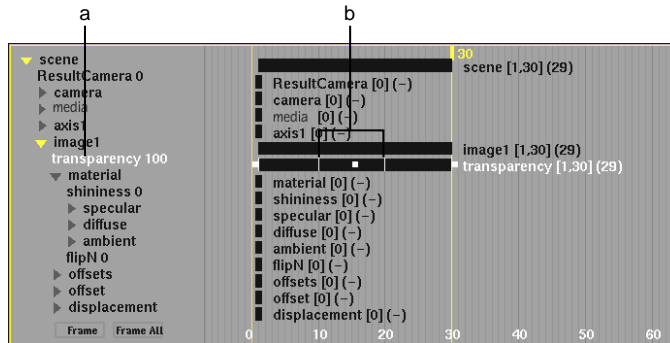

(a) Selected Channel (b) Keyframes can be dragged in time

Setting Keyframes Manually

Set keyframes manually when you want to experiment with animated behaviour, especially for precision animation. Setting keyframes manually using the Set Key button allows for more control than the Auto Key method, since it gives you the chance to try out ideas and discard them quickly without having to undo work. In this way, you only set the keyframes when you are satisfied with the result.

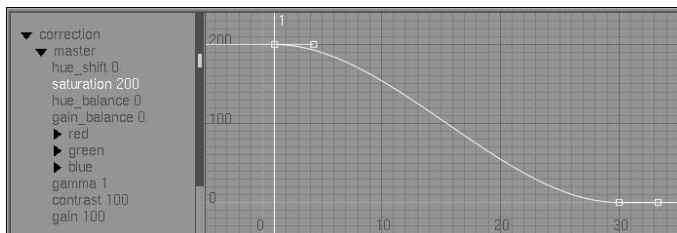

To set keyframes manually using the Set Key button:

- 1 Disable Auto Key.
- 2 Drag the positioner to the frame where you want to set the keyframe.
- 3 In the Channel Editor, select one or more channels.
- 4 Click Set Key.

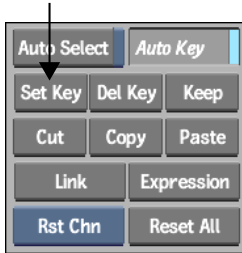

The current values for the selected channels are set in the current frame.

TIP It can be useful to set keys across multiple channels using the Track Editor since this view focuses on channels, and their composing keyframes, in time.

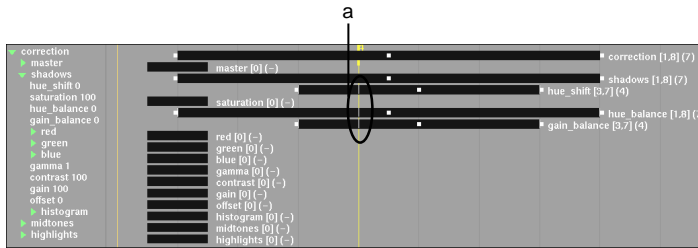

(a) Keyframes set for all selected tracks coinciding with positioner

Inserting Keyframes

Use the Insert Key button and Duration field to insert keyframes with ripple. Ripple occurs when frames are added or removed, thereby increasing or decreasing the length of the animation curve. You can also insert keyframes at the end of an animation curve.

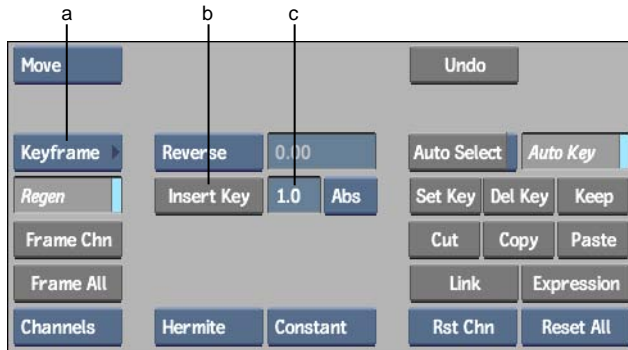

(a) Animation Controls box (b) Insert Key button (c) Duration field

To set keyframes using the Insert Key button and Duration field:

- 1 Select the animation curve that you want to affect.
- 2 Move to the frame where you want to insert a keyframe.
- 3 From the Animation Controls box, select Keyframe.
- 4 Click Insert Key. The Insert Key button behaves differently depending on the current frame:
 - If the current frame is the last keyframe, a new keyframe is created *<duration>* number of frames after the last keyframe (*duration* is the value in the Duration field). The current frame advances to the new keyframe.
 - If the current frame is a keyframe other than the last keyframe, a new keyframe is created *<duration>* number of frames after the present keyframe (*duration* is the value in the Duration field). Other keyframes are moved by the same duration causing a ripple effect.
 - If the current frame is between keyframes, Insert acts the same as the Set button: a new keyframe is created and the duration is unchanged.

Changing the Duration between Keyframes

Use the Duration field to change the duration between two or more keyframes. The Abs/Rel box determines whether the value in the Duration field is absolute or relative to the present keyframe value.

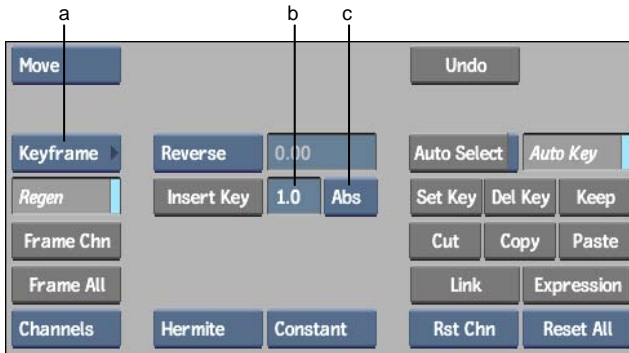

(a) Animation Controls box (b) Duration field (c) Abs/Rel box

To change the duration between keyframes:

- 1 Select the animation curve and keyframes whose duration you want to change.
- 2 From the Animation Controls box, select Keyframe.
- 3 Select how the new duration will be applied using the Abs/Rel box.

Select:	To:
Abs	Force the duration between keyframes to the new duration value.
Rel	Apply the new duration value relative to the present value.

- 4 Enter the new duration value in the Duration field.
The distance between keyframes is changed immediately.

NOTE When positioned on the last keyframe, a value entered into the Duration field has no immediate effect, but the value can be used to insert a new keyframe by clicking Insert Key.

Setting Interpolation

Interpolation defines the shape of an animation curve between keyframes. You set the interpolation mode to determine the smoothness of the transitions for an entire curve or between keyframes. The smoother the transition between each keyframe, the less jitter in your result.

The following table describes the interpolation modes and illustrates the resulting curves. You can set the default interpolation mode used when creating animations in the Preferences menu. The default interpolation is initially set to Hermite.

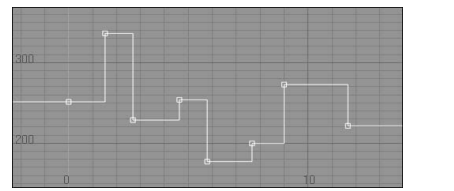
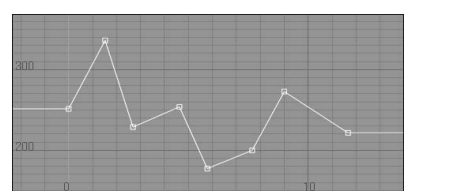
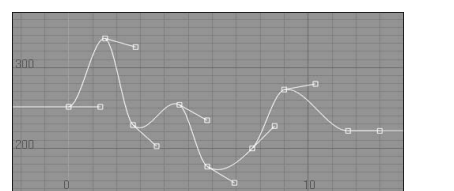
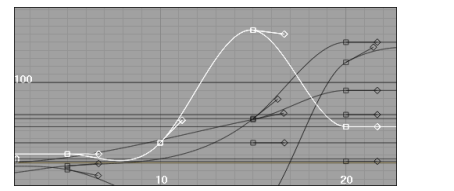
Interpolation Mode	Resulting Curve
<p>Constant—Produces a square curve. The value of one keyframe is held constant until the next keyframe.</p>	
<p>Linear—Joins keyframes using straight lines. Linear interpolation may result in abrupt movement in the animation.</p>	
<p>Hermite—Produces a smooth curve with a smooth transition between keyframes. Each keyframe on the animation curve has an associated tangent handle. You can change the shape of the animation curve by dragging the tangent handle. When you move a tangent handle, it changes to a solid square.</p>	
<p>Natural—Produces a smoother, more continuous curve than Hermite. This animation curve has natural cubic splines, similar to Hermite curves, but the tangents of the spline adjust themselves automatically to match the first and second derivatives at each keyframe. This results in a very smooth curve. Each tangent is re-evaluated when you move a point on the curve.</p>	

Interpolation Mode

Resulting Curve

Mixed—You cannot select Mixed. This option is shown automatically when you select two or more channels that have different interpolation modes, or when an animation curve contains different interpolation modes between keyframes.

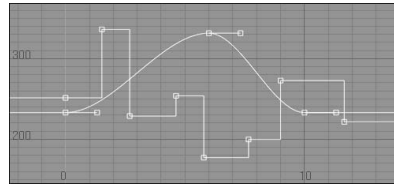

To change the interpolation for an entire curve:

- 1 From the Channel View box, select Channels.

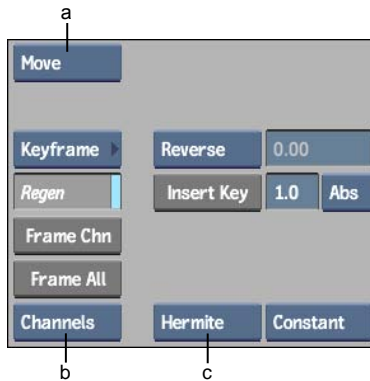

(a) Edit Mode box (b) Channel View box (c) Interpolation box

- 2 From the Interpolation box, select an interpolation mode.
As soon as you select the interpolation, it is applied to the selected curve.

To change the interpolation mode between keyframes:

- 1 Select the first keyframe of a sequential group of two keyframes in the animation curve that you want to change.
- 2 From the Interpolation box, select an interpolation mode.
The interpolation changes between the selected keyframe and the next keyframes. For example, the following figure shows the results of changing a keyframe's interpolation from Constant to Hermite in an animation curve that uses Constant interpolation.

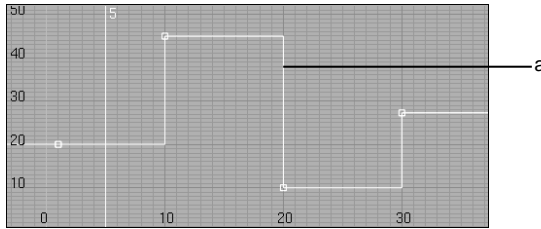

(a) The original animation curve using Constant interpolation

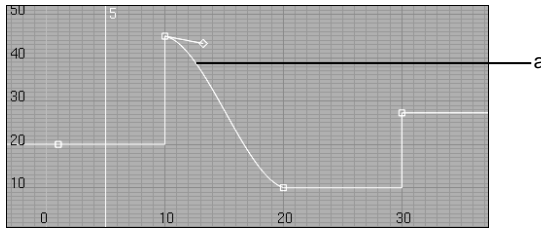

(a) The same curve after changing the second keyframe to Hermite interpolation

To change the interpolation mode for a group of keyframes:

- 1 Press **Ctrl** and select the keyframes for which you want to change the interpolation.

TIP While pressing **Ctrl**, you can also draw a selection box around the group of keyframes you want to select.

- 2 From the Interpolation box, select an interpolation mode.
The selected interpolation is applied to the keyframes.

Setting Extrapolation

Extrapolation defines the shape of an animation curve before the first keyframe and after the last keyframe of the curve. The following table describes the extrapolation modes and illustrates the resulting curves. You can set the default

extrapolation mode used when creating animations in the Preferences menu. The default extrapolation is initially set to Constant.

Extrapolation Mode**Resulting Curve**

Constant—Applies the channel value in the first keyframe to all frames before the first keyframe. The value of the last keyframe is applied to all frames after the last keyframe.

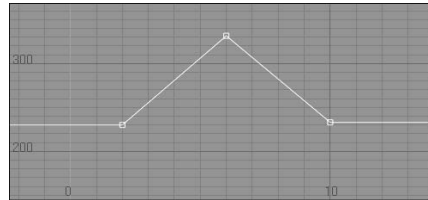

Linear—Continues the curve in a linear fashion before the first keyframe and after the last keyframe.

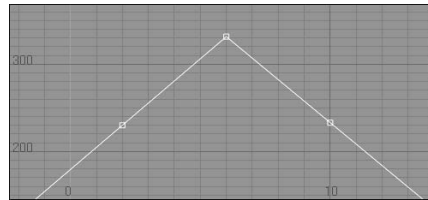

Cycle—Creates cycles in the curve. The period of each cycle is determined by the first and last keyframe.

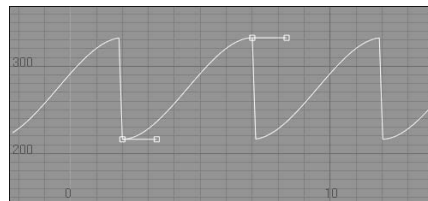

Reverse and Cycle—Repeats, reverses, then cycles the curve.

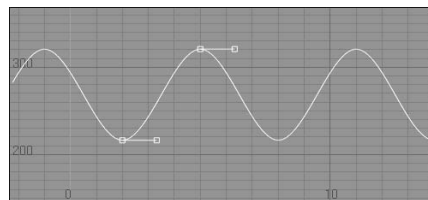

Mixed—You cannot select Mixed. This option is shown automatically when you select two or more channels that have different extrapolations.

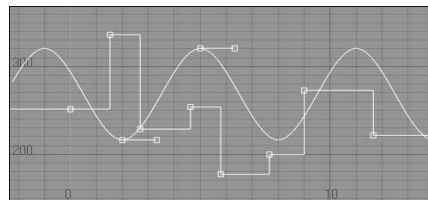

To change the extrapolation:

- 1 Select the animation curve.
- 2 From the Extrapolation box, select an extrapolation mode.

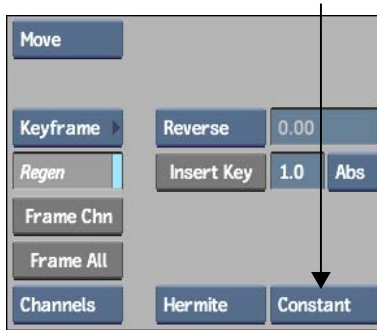

The extrapolation is applied to the selected curve.

Displaying Channels

You can set display options in the Channel Editor to show specific information and hide other information. Displaying information can be as simple as expanding and collapsing folders in the channel hierarchy or as detailed as filtering to show only animated channels. All of the Channel Editor's filter settings for a module can be saved and loaded back into the module on the Desktop, or for the same module accessed through Batch.

Additionally, you can pan and zoom the Channel Editor to focus on a particular section of the Animation Curve window or the Track Editor.

Viewing Channels in a Table

Viewing the Channel Editor in a tabular format makes it easy to navigate the channel hierarchy and locate keyframe information. The tabular information can be sorted by channel value, keyframe, and expression.

To view or browse data in a tabular format:

- 1 Click Animation to display the Channel Editor.
- 2 From the Channel View box, select Info.

The Channel Editor displays the Information Table view.

3 Click one of the following:

- The arrow next to a folder to expand it to view the channels or other folders it contains. Click the arrow again to collapse the folder.

NOTE Scene channels at the top level of the hierarchy cannot be collapsed.

- The Hierarchy View button  to better view the channel hierarchy.
- A channel or folder name to select it. If you select a folder, all the channels and other folders it contains are selected. **Ctrl**-click it again to unselect it.
- A column heading to sort by channel, value, number of keys, or expressions, in ascending or descending order.

TIP When using cascading expressions, the order in which channels are selected is important. To display the selection order, hold **Ctrl** and select channels in the Info channel view. When you select a parent entry, all child entries are numbered sequentially after the parent entry. See [Cascading Expressions](#) on page 2047.

Expanding and Collapsing Channels

As you create animations, the Channel Editor can become difficult to navigate when many folders in the channel hierarchy are expanded. For easy viewing, expand only the channels of interest, such as channels that are animated, and collapse the others.

To expand and collapse channels:

- 1 From the Animation Controls box, select Filter.
The Filter controls appear.

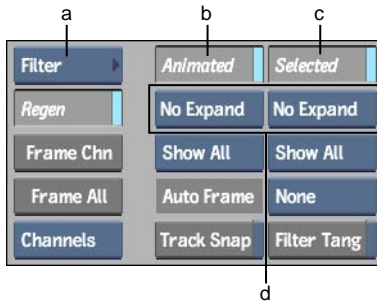

(a) Animation Controls box (b) Animated button (c) Selected button (d) Expansion boxes

- 2 Enable Animated, Selected, or both, depending on the channels you want to select.

TIP Press the comma key (,) to enable or disable the Animated button. Press the period key (.) to enable or disable the Selected button.

- 3 From the corresponding Expansion box, select one of the following options.

Select:	To:
Exp & Col	Expand animated or selected channels and collapse all others.
Expand Only	Expand animated and selected channels. All previously expanded channels remain selected.
No Expand	Not expand animated or selected channels.

The channels are expanded/collapsed according to your selection.

The expand/collapse states of folders are persistent per module and soft effect editor, as well as for Batch, for the current session. You can also save and load filter preferences, which have an effect on whether folders are collapsed or expanded. See [Saving and Loading Filter Preferences](#) on page 1991.

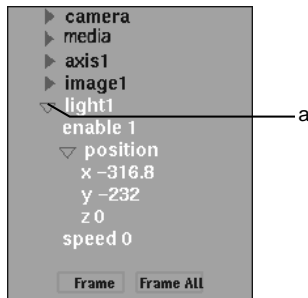

(a) This folder cannot be collapsed until the Expand/Collapse options are changed

Showing and Hiding Channels

In the Channel Editor, you can display all channels simultaneously or only the channels you are currently working with. You have the same control over the display of channels regardless of the channel view you are using in the Channel Editor.

To show or hide particular channels:

- 1 From the Animation Controls box, select Filter.
The Filter controls appear.

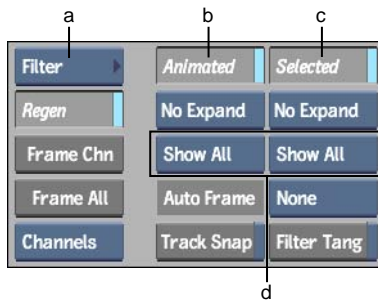

(a) Animation Controls box (b) Animated button (c) Selected button
(d) Show/Hide boxes

- 2 Enable Animated, Selected, or both, depending on the channels you want to select.

- 3 From the corresponding Show/Hide box, select one of the following options.

Select:	To:
Hide All	Show only the animated or selected properties, for example, the X and Y values of an axis. All other properties in the same parent folder are hidden. All other folders are also hidden.
Hide Group	Show only the animated or selected channel, its parent folder, and all channels in the same group, where a group includes all folders in the same parent folder. All other parent folders and groups are hidden.
<hr/> NOTE If multiple channels are animated or selected, all corresponding parent folders and groups are shown. <hr/>	
Show All	Show all animated or selected channels.

Showing Specific Channel Tangents

You can display the tangents of only the selected channels. This can be useful if the Channel Editor is cluttered and you want to concentrate only on a subset of channels to edit.

NOTE Tangents are only displayed in the Animation Curve window.

To show only the tangents of selected channels:

- 1 If necessary, switch to the Animation Curve window by selecting Channels in the Channel View box, or by cycling to it by pressing **F5**.
- 2 Select one or more channels.
- 3 From the Animation Controls box, select Filter.
- 4 Enable Filter Tang.



Only the tangent handles of selected channels are displayed. The tangent handles of unselected channels are hidden.

Selecting Channels Automatically

After you alter a numeric field, the corresponding channel can be selected automatically in the Channel Editor.

To select channels automatically:

- 1 Enable Auto Select.

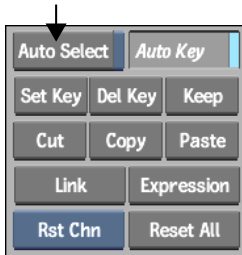

- 2 Change a numeric field such as the X rotation of an axis in Action.
The corresponding channel is selected in the Channel Editor.

NOTE The channel corresponding to the most recently used numeric field remains highlighted in the Channel Editor until another selection is made.

Saving and Loading Filter Preferences

You can save all of the filter preferences in the Filter menu. For example, you can save the filter settings you select when accessing the Channel Editor from the Keyer, then load these back into any other module or soft effects editor. The Channel Editor is then filtered accordingly. You can only have one set of preferences, per user, and another for Batch. The saved preferences are persistent for the user when you restart the application.

To save filter preferences:

- 1 From the Animation Controls box, select User.



- 2 Adjust the filter settings according to what you want to save.
- 3 Click Save Prefs.



The filter settings are saved for the current user, as filter preferences for all the modules, or for Batch, depending on from where you accessed the Channel Editor.

To load filter preferences:

- 1 Enter a module or Batch, depending on where you saved the animation filter preferences.

- 2 From the Animation Controls box, select User.
- 3 Click Load Prefs.

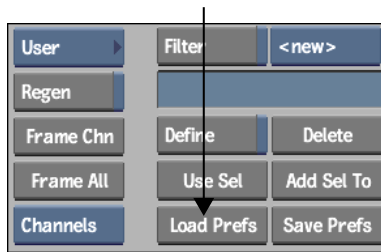

The filter settings are loaded, and the Channel Editor is filtered accordingly.

NOTE Saved filter preferences are also loaded whenever animation parameters are reset.

Framing Channels

You can frame selected channels in the Animation Curve window or the Track Editor so that they completely appear in the channel view, from the first keyframe to the last keyframe. When framing a channel with an expression applied to it, the channel is framed from the minimum to the maximum frames in the sequence.

In the Animation Curve window, framing channels brings the full shape of the animation curves into view, including all curve peaks and troughs. In this channel view, you can also frame smaller regions of animation curves by first selecting individual keyframes.

In the Track Editor, framing channels brings the total duration of the tracks in view.

You can also automatically frame particular channels according to criteria you set in the Filter menu. For example, you can set all animated channels to be automatically framed.

Framing controls are available from the Animation menu, and from the channel hierarchy.



To frame channels:

- 1 From the Animation Controls box, select Filter.
- 2 From the Auto Frame box, select None.



- 3 Do one of the following:
 - On the channel hierarchy, click one of the following buttons.

Click:	To frame:
Frame	Selected channels.
Frame All	Animation curves for all expanded channels.

- From the Animation menu, select one of the following options.

Select:	To frame:
Frame Chn	Selected channels.
Frame All	Animation curves for all expanded channels.

NOTE The Frame Chn and Frame All buttons are only available when None is selected in the Auto Frame box. Press the forward slash key (/) to toggle Auto Frame between None and the last selected option (All, Animated, or Selected).

- 4 Press **Ctrl** and click Frame Chn in the Animation menu or Frame on the channel hierarchy to frame the selected channel and scroll the corresponding folder to the top of the channel hierarchy.

TIP You can press **Shift+Tab** to simultaneously frame the selected channels as well as expand them in the channel hierarchy.

To frame regions of channels:

- 1 From the Animation Controls box, select Filter or Keyframe.
- 2 From the Auto Frame box, select None.
- 3 Using the Animation Curve window, select keyframes from one or more channels.
- 4 Click Frame Chn in the Animation menu or Frame on the channel hierarchy.

Regions of the animation curves from which you selected keyframes are framed in the Animation Curve window.

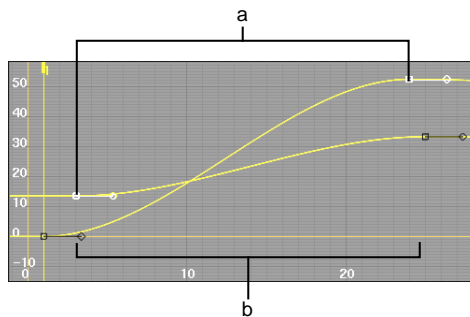

(a) Selected keyframes from different channels (b) Framed regions of channels based on selection

TIP You can press **Shift+Tab** to simultaneously frame the selected keyframes as well as expand the channels they belong to in the channel hierarchy.

To have channels automatically framed:

- 1 From the Animation Controls box, select Filter.
- 2 Select one of the following options from the Auto Frame box.



Select:	To frame:
All	All channels.
Animated	All animated channels.
Selected	All selected channels.
None	No channels. This option enables the Frame Chn and Frame All buttons in the Animation controls.

The corresponding channels are automatically framed.

TIP Press the forward slash key (/) to toggle Autoframe between None and the last selected option (All, Animated, or Selected).

Defining a Selection Set

You determine the filter to apply to the Channel Editor by creating a selection set. A selection set includes all the channels, folders, and folder elements that you want to display as part of a set. By defining a selection set, you can select to show only certain channels, folders, and folder elements and to hide all the others. You can navigate the Channel Editor more easily and isolate groups of channels that you are animating. Define selection sets with the User controls by choosing the channels to appear in the selection set.

You can base the content of your selection set on your current selection. Examples of your current selection include channels and folders selected in

the Channel Editor, or nodes selected in the schematic. You can add selections to your selection sets and refine selection sets.

Selection sets are applicable to all channel views in the same way.

Start by making your selection and then naming and creating a selection set. Selection sets are saved with setups.

To make your selection:

- 1 There are several methods for making your selection. For example:

In:	To make a selection:
The schematic	Click an individual node or hold Ctrl and drag a box around a group of adjacent nodes.
The Channel Editor	Click a channel or folder in any of the channel views. If a parent folder is selected, all children are selected also.

To name and create a selection set:

- 1 From the Animation Controls box, select User. The User controls appear.

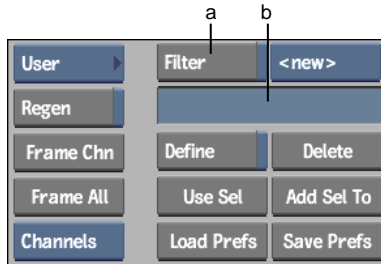

(a) Filter button (b) Selection Set Name field

- 2 Enable Filter.
- 3 Type a name in the Selection Set Name field and press **Enter**. The selection set is named and created.

To switch between selection sets:

- 1 From the Animation Controls box, select User.

- 2 In the User controls, select a different selection set from the Selection Set box.

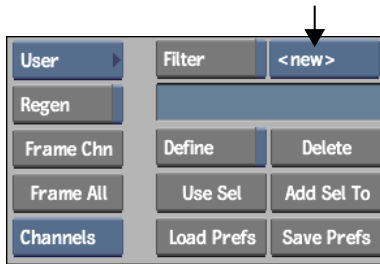

- 3 If the selection set is not visible in the channel hierarchy, drag in the channel hierarchy until the selection set becomes visible.

TIP If you still have difficulty viewing a selection set, select Keyframe from the Animation Controls box, then **Ctrl**-click Frame Chn. The top of your selection set is aligned with the top of the Channel Editor.

Basing Your Selection Set on Your Current Selection

You can either replace or add to an existing set with the current selection. This is useful when working on a group of nodes in the schematic. After selecting nodes in the schematic, you can choose to display them in the Channel Editor. If required, display further channels based on successive selections in the schematic.

Use the Selection Set box to choose your selection set.

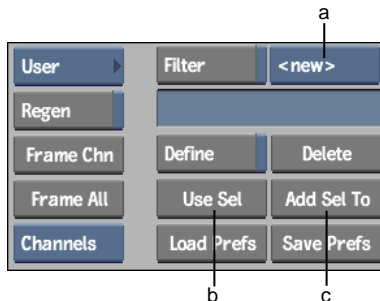

(a) Selection Set box (b) Use Sel button (c) Add Sel To button

To replace an existing selection set with your current selection:

- 1 Select a selection set from the Selection Set box.
- 2 Make your selection.

NOTE Step 2 can be completed before step 1.

- 3 Click Use Sel.

The current selection is displayed in the Channel Editor and this selection is saved as the current set. All other channels and folders are hidden.

To add your current selection to a selection set:

- 1 Select a selection set from the Selection Set box.
- 2 Make your selection.

NOTE Step 2 can be completed before step 1.

- 3 Click Add Sel To.

The current selection is added to the current selection set. The newly selected channels are displayed in the Channel Editor and saved as part of the current selection set.

Refining Selection Sets in the Channel Editor

Refine your selection set using the Define button. This method of defining the contents of a selection set is particularly useful in a module without a schematic, such as the Colour Corrector.

To modify a selection set from the Channel Editor:

- 1 Select a selection set from the Selection Set box.
- 2 Enable Define.

All channels are shown in the Channel Editor and are either green or red. Green channels are included in the current selection set and red ones are excluded from the set.

- 3 Click channels to include in or exclude from the current selection set. Click a channel again to change its colour.
- 4 Disable Define.

The selections made in the Channel Editor are displayed and are also saved as part of the current selection set. All other channels and folders are hidden.

TIP To display all folders and channels again, disable Filter.

Panning and Zooming Channels

You can pan and zoom in the Animation Curve window and Track Editor as you view channels. Use a rectangular zoom to enlarge a particular region and use ordinary zoom to enlarge or reduce the display. Select an option from the Animation controls.



(a) Edit Mode box (b) Animation Controls box

To pan:

- 1 From the Edit Mode box, select Pan (or press **Alt+P**).
- 2 Position the cursor in the Animation Curve window or Track Editor and drag in any direction.
You can also pan in any mode by pressing **spacebar** and dragging in the Animation Curve window.
- 3 To zoom out, select either Frame All or Frame Chn.

To zoom:

- 1 From the Edit Mode box, select Zoom (or press **Z**).
- 2 Click in the Animation Curve window or Track Editor.

The cursor changes to a magnifying glass.

- 3 To zoom in, drag right. To zoom out, drag left.
You can also zoom in any mode by pressing **Ctrl+spacebar** and dragging in the Animation Curve window.

To zoom with Rectangular Zoom:

- 1 From the Edit Mode box, select Rect Zoom (or press **C**).
- 2 Position the cursor in the Animation Curve window or Track Editor and drag diagonally to draw a rectangle over the region to enlarge.
The selected region is enlarged.
- 3 To zoom out, click the Frame All or Frame Chn button:
 - To frame all the curves in the Animation Curve window, click Frame All.
 - To frame the selected curve in the Animation Curve window, click Frame Chn.

Colouring Channels and Folders

Use the Colour option in the Curve Functions box to change the colour of channels or folders. This is useful when you want to differentiate animation curves, or tracks.

The same colour is used for the channel in Channel, Track, and Info views.

To colour channels or folders:

- 1 Select the folders or channels to colour. See [Selecting Multiple Keyframes and Channels](#) on page 2007.
- 2 From the Animation Controls box, select Keyframe.
- 3 From the Curve Functions box, select Colour.

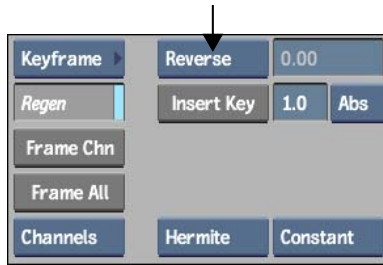

- 4 Use the colour picker that appears to select a colour.
- 5 Click the Current Colour pot.

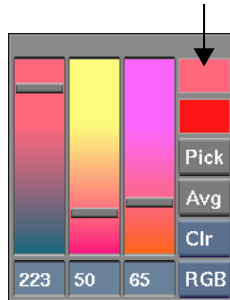

The colour of the selected channels, or all channels within the selected folder, changes. To cancel without colouring a channel, click the empty portion of the menu, above the colour picker.

Editing Keyframes

As you create animations and set keyframes for channels, you need to be able to edit keyframe values, delete keyframes, as well as modify animation curves and groups of keyframes.

Copying and Pasting Channels or Keyframes

Use the Copy and Paste buttons to copy and paste animation curves or keyframes between channels. You can copy and paste folders provided the folder to which you are pasting has the same number of channels and folders as the folder you copied. For example, in Action, you can copy the Scale folder from an axis and paste it into the Scale folder of another axis because they

have the same channels (X scale, Y scale, for example). Trying to copy and paste the Camera folder to the Scale folder will not work because the two folders do not contain the same number and kinds of channels.

NOTE If an expression is applied to the selected channel, the expression is copied instead.

To copy and paste a selection of keyframes:

- 1 Select keyframes on a channel, and click Copy.

TIP Keyframes do not have to follow one another to be copied and pasted to another channel.

- 2 Drag the positioner to a new frame.
- 3 Paste the copied keyframes using one of the following methods:
 - Select the channel where the keyframes will be pasted, then click Paste. This pastes the keyframes at the current frame.
 - In Move mode, **Shift+spacebar**-click a channel to paste keyframes starting from the location of the cursor. For example, **Shift+spacebar**-click frame 10 on a channel to paste the copied keyframes into the channel starting at frame 10.

The keyframe values for the selected channels are pasted and set in the current frame.

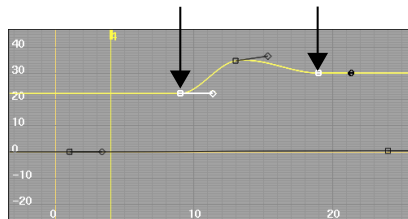

Selected non-contiguous keyframes

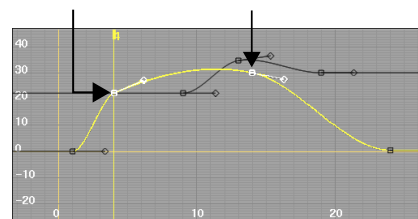

Selected keyframes pasted to second animation curve beginning from positioner

To copy and paste a curve:

- 1 From the Channel View box, select Channels.



- 2 Select the channel containing the animation curve.

TIP Select a folder to copy all the channels in a folder.

- 3 Click Copy.
- 4 Select the channel where you want to paste the copied curve.
- 5 Click Paste.
The channel values you copied are applied to the selected channel or folder.

Adding Keyframes

You can add keyframes to a channel's animation curve. Added points are unlocked and appear as square outlines on the curve. Adding a keyframe to the animation curve does not add a vertex to a motion path. See [Modifying Motion Path Speed](#) on page 2026 for details about using Add mode with motion paths.

To add a keyframe:

- 1 Select the channel.
- 2 From the Edit Mode box, select Add (or press **A**).
- 3 Position the cursor at the coordinates (frame number and value) where you want to add the keyframe and click.

The keyframe is added at the specified coordinates for all selected channels. You can also move the new keyframe after it is added. In the Animation Curve window, the shape of the animation curve and the slope of the new keyframe are generated automatically.

Deleting Keyframes

You can delete one or more keyframes from an animation curve or track. You can also delete keyframes from more than one channel.

To delete a keyframe:

- 1 Access the Animation Curve view or the Track Editor.
- 2 Select the channel containing the keyframe you want to delete.
- 3 From the Edit Mode box, select Delete (or press **D**).
- 4 Click the keyframe.

The keyframe is removed from the curve or track. In the Animation Curve window, the shape of the animation curve is updated automatically.

To delete all keyframes at a specific time:

- 1 Access the Animation Curve window or the Track Editor.
- 2 Drag the positioner to the frame where you want to remove keyframes.
- 3 Select the channels containing the keyframes you want to delete.
- 4 Click Del Key.

The keyframes for the selected channels are deleted for the current frame.

To delete a range of keyframes:

- 1 Access the Animation Curve window or the Track Editor.
- 2 Select the channels containing the keyframes you want to delete.
- 3 From the Edit Mode box, select Delete (or press **D**).
- 4 Drag a selection box around the keyframes.

When you release the cursor, all keyframes inside the selection box for the selected channels are deleted. Animation curves are updated automatically. Unselected keyframes and keyframes in collapsed folders are unaffected.

To delete all keyframes except the current keyframe:

- 1 Access the Animation Curve window or the Track Editor.
- 2 Select the channel containing the keyframes you want to delete.

- 3 Press **Ctrl** and select the keyframe you want to keep.
- 4 Click the Keep button.

The selected keyframe is kept, while all other keyframes are deleted.

NOTE If no keyframes are selected in the currently selected channel, the entire channel is deleted.

Moving Keyframes

You can change the position of a keyframe or tangent handle on an animation curve.

If you move a keyframe, the frame number (horizontal) and keyframe value (vertical) coordinates of the keyframe are updated and displayed. The shape of the curve is updated automatically.

If you move a tangent handle, the value of the slope is updated and displayed. After a tangent handle is moved, it appears as a solid square.

While moving a keyframe in the Animation Curve window, press **Alt** to snap the frame value (vertical axis) to the nearest integer. Press **Ctrl+Alt** to snap to the nearest multiple of ten.

To move a keyframe or tangent handle:

- 1 Access the Animation Curve window or the Track Editor. To both move keyframes on the Y-axis and adjust tangent handles, you must use the Animation Curve window.
- 2 From the Edit Mode box, select Move (or press **M**).
- 3 Select and drag the keyframe or tangent handle that you want to move to a new position. You may have to click the Frame Chn button to view the curve.

TIP When you move keyframes in the Animation Curve window, you may want to move the keyframe strictly on the X-axis or strictly on the Y-axis. To lock keyframe movement to the X- or Y-axis, hold **Shift** as you move the keyframe. The keyframe movement will be locked to the X-axis if your initial movement is horizontal and to the Y-axis if your initial movement is vertical.

Snapping Keyframes between Frames

Sometimes keyframes fall between frames and need to be snapped back. This may occur when using a function such as XScale, after importing animated material from another application, or when using the Track Editor to change the timing of an animation.

To fix keyframes that fall between frames:

- 1 In the Channel Editor, select a channel or group of keyframes.
- 2 From the Curve Functions box, select FrmSnap.

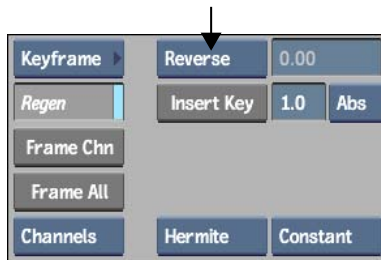

All selected keyframes snap to the closest frame.

To snap keyframes to frames as you drag tracks:

- 1 Do one of the following:
 - Select Filter from the Animation Controls box and then enable Track Snap.



- Hold **Alt+Z** as you drag a track with its left or right handle.

NOTE If Track Snap is enabled and you drag a track holding **Alt+Z**, the opposite effect occurs: keyframes can fall between frames.

After the track is scaled in time, its keyframes snap to the closest frame.

Selecting Multiple Keyframes and Channels

You can select multiple keyframes or channels to edit them in tandem. Do this, for example, to modify every second keyframe in an animation curve or to apply the same modification to two or more channels from different folders.

NOTE You can select a channel in Move or Select mode by clicking its name in the channel hierarchy, or clicking the channel with the cursor.

To select multiple channels:

- 1 From the Edit Mode box, select Move or Select.
- 2 Click a channel in the hierarchy to select it.

TIP You can also select channels by clicking their animation curve or track.

When a channel is selected, its name and animation curve are highlighted. As well, if the channel corresponds to an element in the image window, the element is highlighted there. For example, if you select the Axis channel for a clip, its axis is highlighted in the image window.

- 3 **Shift**-click another channel to add it to the selection. **Shift**-click a selected channel to deselect it.

To select multiple keyframes:

- 1 From the Edit Mode box, select Move or Select.
- 2 Select one or more channels in the hierarchy.
- 3 Drag a selection box around the keyframes. If you are using Move mode, **Ctrl**-drag to create a selection box. If you are using Select mode, just drag to create a selection box.

All keyframes inside the selection box are selected.

- 4 **Ctrl**-click another keyframe to add it to the selection. **Ctrl**-click a selected keyframe to deselect it.

To select multiple keyframes from a selected channel:

- 1 From the Edit Mode box, select Move or Select.

- 2 Select one or more channels in the hierarchy.
- 3 Hold down **Ctrl+F** and drag the selection box along the horizontal axis. The keyframes of the selected channels within the drag range are selected. For example, dragging the selection box over the first ten frames of an animation selects all keyframes that fall within those ten frames.

Changing the Timing of an Animation

You can change the duration of an animation by scaling its channel horizontally in the Channel Editor. This allows you to change the number of frames it takes for an animation to play through, without having to move each keyframe manually.

There are two methods to do this: using the XScale edit mode in the Animation Curve window, or by dragging the left or right handle of a track in the Track Editor.

Using XScale allows you to scale the channel using any keyframe as the origin of the scale. Dragging with a track's handle scales the track proportionally vis-a-vis the opposite handle.

When changing the length of channels, you may want to adjust the number of frames of the clip in the Total Frames field. For example, if you shorten the length of all the clip's channels, you can then shorten the clips' frames accordingly. Or, if you scale the channels longer than the duration of the clip, you can then add frames to account for this.

To use XScale on a channel or group of keyframes:

- 1 Display the Animation Curve window.
- 2 From the Edit Mode box, select XScale (or press **X**).
- 3 Select a channel or several channels in the hierarchy. You may have to click Frame Chn to view the curve.
- 4 Click the keyframe that will act as the centre of the XScale. Drag left to decrease the value or drag right to increase the value of the other keyframes along the X-axis, relative to the selected keyframe.

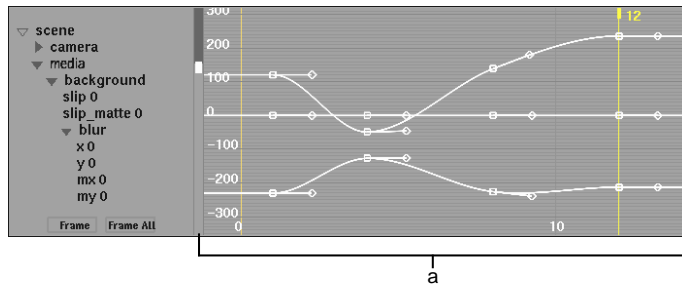

(a) Original animation curve

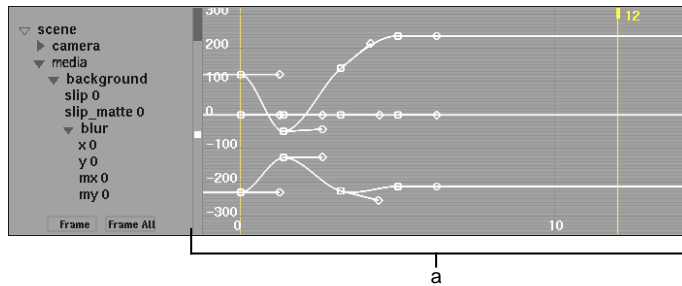

(a) XScale used to compress curves

To scale a channel in the Track Editor:

- 1 Access the Track Editor.
- 2 From the Edit Mode box, select Move.
- 3 Select a track to access its handles.
- 4 Drag the left or right handle of a track.

NOTE Increasing or decreasing the length of an animation may result in keyframes between frames. When this happens to the first or last keyframe, a decimal value is given to the keyframe value. See [Snapping Keyframes between Frames](#) on page 2006.

The track scales as you drag the handle vis-a-vis the opposite handle. All its keyframes are repositioned proportionally in time.

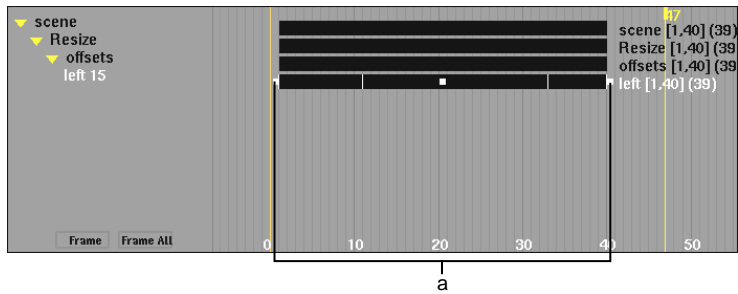

(a) Original animation track

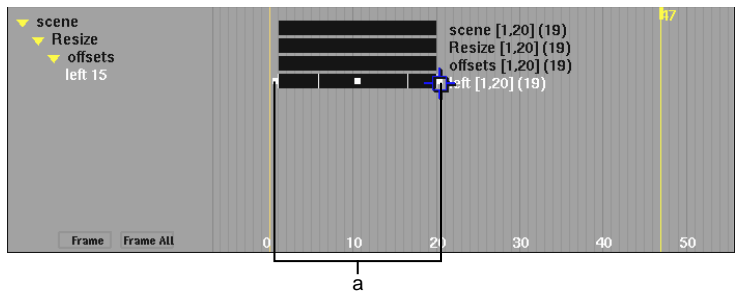

(a) Dragging handle used to compress a track from 40 to 20 frames

TIP You can move the handle of a folder to scale all channels in the folder. For example, moving the handle of the Scene folder (the top level folder) causes all the folders and channels in the hierarchy to be scaled by the same amount.

Changing Keyframe Values Proportionally

You can change the vertical scale of an animation curve or a selection of keyframes and change keyframe values for a channel or a group of keyframes while maintaining each keyframe's relative frame position. These functions are performed using the Animation Curve window.

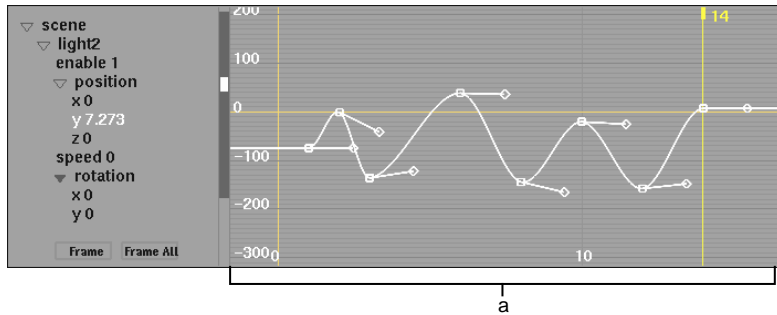

(a) Original animation curve

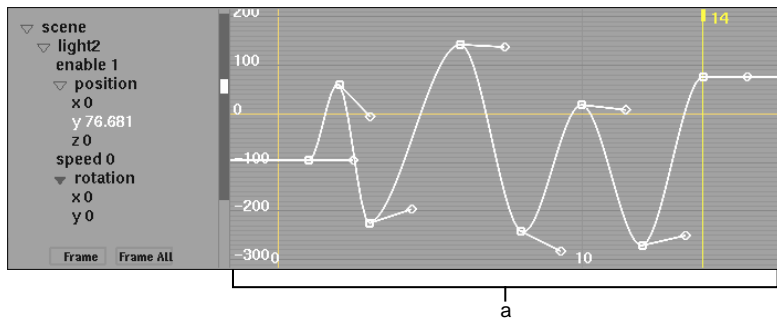

(a) YScale used to scale the curve based on a selected keyframe

To use YScale on a channel or group of keyframes:

- 1 In the Animation Curve window, select a channel or group of keyframes. You can select more than one channel or a group of keyframes from more than one animation curve.
- 2 From the Edit Mode box, select YScale (or press **Y**).
- 3 Click the keyframe that will determine the centre of the YScale.
- 4 Drag up to increase the value or down to decrease the value of the other keyframes relative to the selected keyframe.

YScale works differently if you select more than one curve. For the other selected curves, the number of the frame that you select is verified in all animation curves. If the animation curve has a keyframe at the selected frame, this keyframe is used as the centre of the Yscale. This keyframe then sets the proportional scale calculation. If the animation curve does not have a keyframe at the selected frame, the curve remains unscaled.

Changing the Timing or Values of Keyframes

In the Animation Curve window and the Track Editor, you can translate an animation curve, track, or a selection of keyframes horizontally to change the timing of keyframes.

In the Animation Curve window, you can also translate an animation curve or a selection of keyframes vertically to increase or decrease keyframe values.

To translate a channel or a group of keyframes:

- 1 Access the Animation Curve window or the Track Editor.
- 2 Select a channel.
- 3 From the Edit Mode box, select Translate (or press **T**).
- 4 Click in the Animation Curve window or Track Editor and drag in any direction.
The animation curve or track is moved. The relative positions of keyframes remain unchanged.

To translate a channel in the Track Editor using a handle:

- 1 Access the Track Editor.
- 2 Select one or more channels in the hierarchy to access their handles. You can also select a folder to access its handles.
- 3 Drag the middle handle of any of the selected tracks.
The selected tracks are translated in time. Their composing keyframes remain in the same relative position to one another, and their values are not affected.

Offsetting Channels

You can offset a curve or a group of keyframes on the horizontal or vertical axis. The offset value is set using the Curve Value field.

To offset a channel:

- 1 Select the channel or keyframes to offset.
- 2 From the Curve Functions box, select Translate X to offset the channel horizontally or Translate Y to offset vertically.

- 3 Enter a value in the Curve Value field.

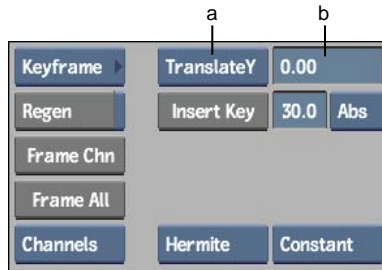

(a) Curve Functions field (b) Curve Value field

A negative value offsets the channel or group of keyframes to the left (Translate X) or down (Translate Y). A positive value offsets to the right (Translate X) or up (Translate Y). The value in the Curve Value field produced by the drag returns to zero after release.

The selected channel or keyframes are offset. The coordinates of each selected keyframe, relative to each other, remain unchanged. Translating along the Y-axis is only visible in the Animation Curve window.

Simplifying the Number of Keyframes

You can change the number of keyframes in your animation curve or in a group of keyframes. Using the Simplify function, the peaks and valleys in the selection are analysed and keyframes are generated with a duration between them as specified in the Curve Value field. A large value such as 20 or 30 decreases the number of keyframes between peaks and valleys, whereas a small value such as 1 or 2 increases the number of keyframes. The ideal simplify value varies between animation curves.

For example, the following figure shows an animation curve created using the Stabilizer. Simplify is applied with a value of 20. In sections where the slope of the curve is fairly constant in one direction, keyframes are removed between the peaks and valleys. You can adjust the simplified animation curve more easily because there are fewer keyframes to modify.

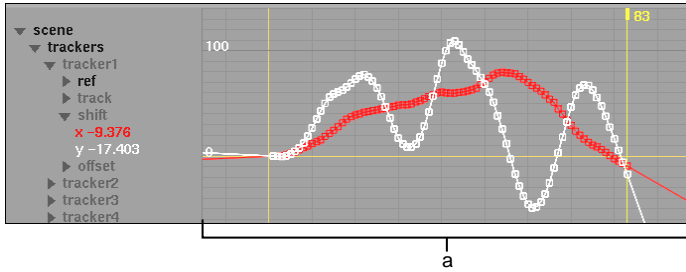

(a) The Y curve before applying Simplify has a keyframe at each frame

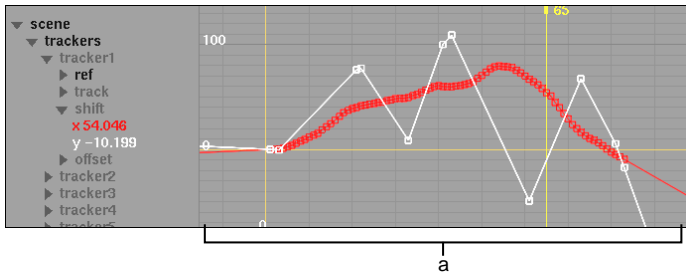

(a) The Y curve after applying Simplify with a simplification value of 20.

To simplify a channel or a group of keyframes:

- 1 Select a channel or group of keyframes.
- 2 From the Curve Functions box, select Simplify.

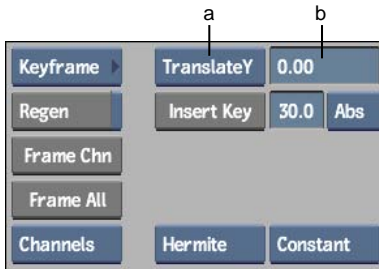

(a) Curve Functions box (b) Curve Value field

- 3 In the Curve Value field, enter a simplification value.

Use a large number to simplify the curve or group of keyframes. Use a small number to increase the number of keyframes. The value in the Curve Value field produced by the drag returns to zero after release.

Baking Keyframes

You can transform a curve or a group of keyframes by using the Bake function. This can be useful if you want to change an extrapolated cycle curve into a normal curve, with keyframes created along the cycle. You can also use the Bake function to remove the dependence of a curve linked to another curve with an expression.

To bake a cycled curve:

- 1 Select a curve that has a cycle extrapolation applied to it.
- 2 Set the current frame to the last frame that you want to be baked.
- 3 From the Curve Functions box, select Bake.

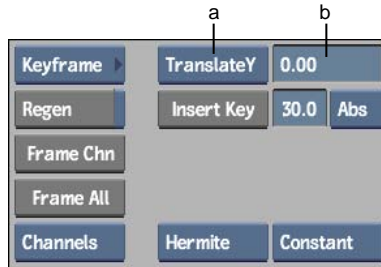

(a) Curve Functions box (b) Curve Value field

- 4 In the Curve Value field, enter a bake value.
Use a large number to simplify the curve or group of keyframes. Use a small number to increase the number of keyframes. The value in the Curve Value field returns to zero after you have finished baking.

Breaking Keyframe Tangent Handles

Use Break mode in the Edit Mode box to split a keyframe's tangent handle into two tangent handles. Breaking tangent handles creates a discontinuity

in an animation curve, enabling you to move each tangent handle separately and have more control over the slope of the animation curve.

The following example shows a keyframe before and after using Break mode.

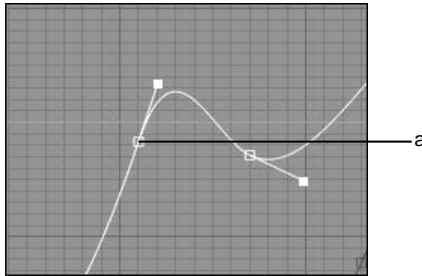

(a) The original keyframe.

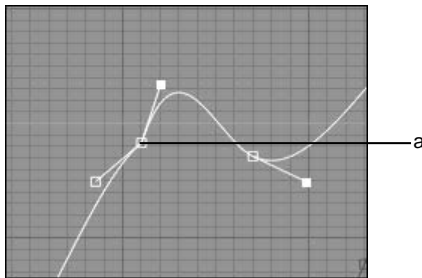

(a) Break was used to split the keyframe's tangent handle. The two tangent handles were then moved. Notice the slope has changed on either side of the keyframe.

NOTE Only animation curves that use Hermite or Natural interpolation have keyframes with tangent handles. See [Setting Interpolation](#) on page 1980.

Using Break mode is also convenient for tweaking the timing of a motion path. See [Working with Motion Path Tangent Handles](#) on page 2028.

To break a tangent handle into two:

- 1 Access the Animation Curve window.
- 2 From the Edit Mode box, select Break.
- 3 Click the keyframe you want to split.

Two tangent handles appear for the keyframe. Each tangent handle appears as an outlined square and controls the shape of the curve on its

respective side. Click the keyframe again to recombine the handles into a single tangent.

NOTE If two channels overlap, you may have to select the channel first before using Break.

- 4 From the Edit Mode box, select Move mode and move one or both tangent handles.

As you move the handles, the slope on each side of the keyframe is modified independently.

Resetting a Tangent Handle

You can reset a keyframe after its tangent handle has been moved in the Animation Curve window. You can also reset a split tangent handle.

NOTE Tangent handles appear only on animation curves that have Hermite or Natural interpolation. See [Setting Interpolation](#) on page 1980.

To reset a tangent handle in Auto mode:

- 1 Access the Animation Curve window.
- 2 From the Edit Mode box, select Auto.
- 3 Click the tangent handle.
It resets to its default value. The slope of the animation curve is updated automatically.

To reset a tangent handle in Move mode:

- 1 Access the Animation Curve window.
- 2 From the Edit Mode box, select Move.
- 3 In the Channel Editor, **Alt**-click a tangent handle.
It is reset to its horizontal position.

To reset a split tangent handle:

- 1 Access the Animation Curve window.
- 2 Select one or more keyframes with split tangent handles.

- 3 Click Reset Chn.
The selected keyframes' tangent handles are reset.

Modifying the Shape of an Animation Curve

You can modify the shape of an animation curve by rotating its keyframe tangent handles to control the smoothness and speed of the animation.

To rotate a keyframe's tangent handles:

- 1 Select a channel or group of keyframes.
- 2 From the Curve Functions box, select Tangent R to rotate each right tangent handle or select Tangent L to rotate each left handle.

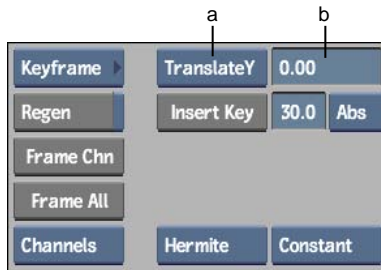

(a) Curve Functions box (b) Curve Value field

NOTE Tangent R and Tangent L only work on curves and keyframes that use Hermite or Natural interpolation. See [Setting Interpolation](#) on page 1980.

- 3 Enter a value in the Curve Value field.
A negative value rotates each tangent counter-clockwise. A positive value rotates each tangent clockwise.
The tangent handle first breaks into two and then the handles are rotated.
The following example shows the results of applying Tangent L with a rotation value of 36 to the keyframes of an entire curve. No keyframes were broken before Tangent L was applied.

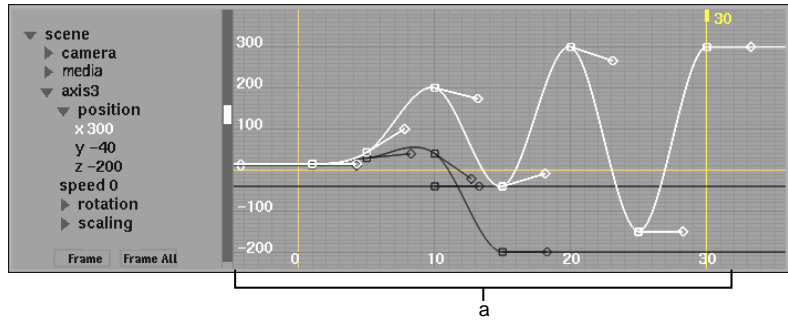

(a) The curve before applying Tangent L. Note that none of the keyframes are broken.

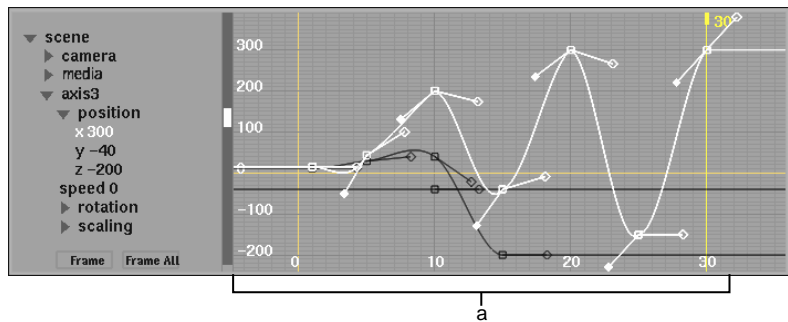

(a) The curve after applying Tangent L of 36. A break is applied to all keyframes before the tangents are rotated.

Swapping Animation Curves

You can swap animation curves between two channels. Swap works in conjunction with Copy or Cut. You can also swap single keyframes but not a group of keyframes.

To swap two channels:

- 1 Select the first channel to swap.
- 2 Click Cut or Copy.
The selection is copied to the clipboard.
- 3 Select the second channel to swap.

- 4 From the Curve Functions box, select Swap.

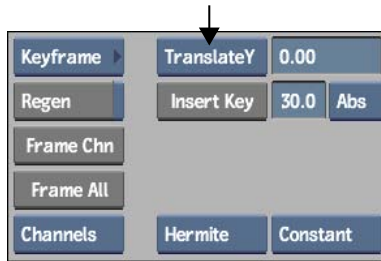

The selected channel is swapped with the channel in the clipboard.

- 5 Select the first channel and click Paste.
The two channels are swapped.

Flipping Channels and Keyframes

Select Negate in the Curve Functions box to flip a channel or a group of keyframes vertically. Select Reverse to flip a channel or a group of keyframes horizontally. Typically, you reverse or flip keyframes so that you can create symmetry with an animation. For example, use Reverse on an image that is warping from a sphere to a flat plane so that it then goes from a flat plane back to a sphere again. Perform these functions in the Animation Curve window.

To negate or reverse a channel or group of keyframes:

- 1 Access the Animation Curve window.
- 2 Select a channel or group of keyframes.
- 3 From the Curve Functions box, select Negate or Reverse.

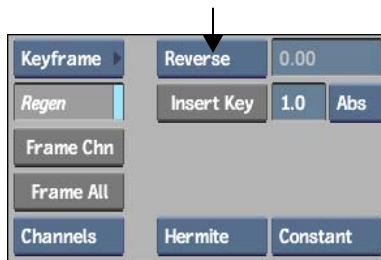

The selection is flipped horizontally (negate) or vertically (reverse).

Removing Jitter from an Animation Curve

Select Jitter in the Curve Functions box to remove jitter from an animation curve or within a group of keyframes. Use the Curve Value field to specify the Over value. As a general rule, start with a large Over value over n frames to remove slow jitter, and a small Over value to remove fast jitter. The Jitter option is typically used on shift data in the Stabilizer to remove jitter while keeping camera movement. See [Removing Jitter While Keeping Overall Motion](#) on page 1796.

To remove jitter:

- 1 Select a channel or group of keyframes.
- 2 In the Curve Value field, specify the Over value.
- 3 In the Curve Functions box, select Jitter.

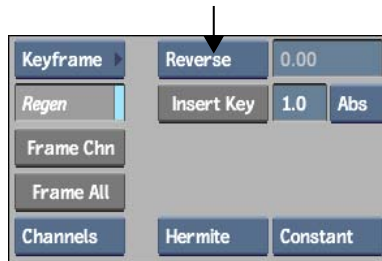

Applying an Average

Select Average in the Curve Functions box to remove jitter from a jittery animation track. While the Jitter option is used for removing jitter caused by trackers in the Stabilizer, the Average option is used to remove jitter from an animation track. Enter the number of keyframes used to calculate the average in the Curve Value field.

You can change the timing of a motion path animation without changing the motion path spline by adding a keyframe to the speed curve.

To average a channel:

- 1 Select a channel or group of keyframes.
- 2 Select Average from the Curve Functions box.
- 3 In the Curve Value field, specify a value.
The jitter is removed from the spline animation.
- 4 From the Edit Mode box, select Break.
- 5 In the Animation Curve window, click a keyframe on the speed channel.
The keyframe breaks into two tangents.

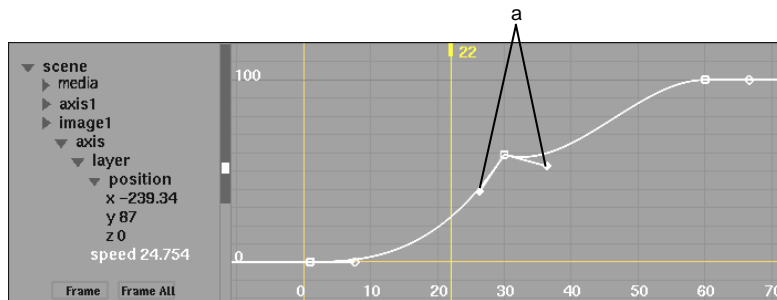

(a) Keyframe tangents

- 6 From the Edit Mode box, select Move.
- 7 Adjust the tangents.
In this example, the speed curve makes the apple accelerate rapidly until it reaches frame 29, where it stops and continues moving slowly.

You can also apply the preceding procedure to a group of keyframes.

Controlling the Speed of Objects

You can control the speed of an object along its motion path with the Speed channel. The speed adjustments do not affect the motion path itself. For objects where you control position explicitly, such as the position of media in Action, you can still control speed by manipulating position keyframe tangent handles on the animation curves in the Channel Editor.

Creating a Motion Path

With motion path animation, object positions follow a spline (curved line) that you create in the image window. By creating a motion path, you have a visual reference for the object's position. Use motion paths to animate the position of any of the following:

- **Action**—axes, light sources, camera eye, or camera point of interest, or particle manipulators. Use the Path button in the Axis and Light menus to enable or disable motion path animation for the selected axis or light. Use the Path button in the Camera menu to enable or disable motion path animation for both the camera eye and point of interest.
- **Compositor**—the camera or the object. The Compositor menu contains the Object and Camera buttons. Use the Object button to enable or disable motion path animation for the object. Use the Camera button to enable or disable motion path animation for the camera.
- **Keyer**—garbage masks for the selected axis. In the GMask menu, use the Path button to enable or disable motion path animation for the selected Keyer garbage mask.

The following procedure illustrates how to create a motion path for a 3D object (an apple) over a 30-frame clip in Action. The 3D object follows a motion path spline that is drawn from the upper-left corner at frame 1 to the lower-right corner at frame 30.

To animate a 3D object in Action:

- 1 In the Axis menu, enable Path.
- 2 If you want to set the spline vertices automatically, enable Auto Key.
- 3 Move the positioner to frame 1.
- 4 Click the object's axis and drag the object to the upper-left corner of the image window.

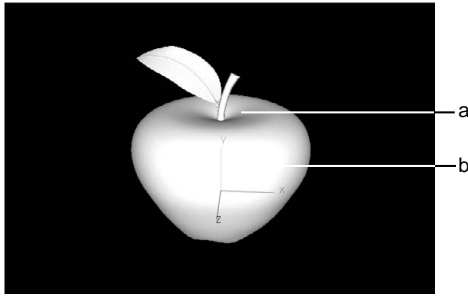

(a) The object (b) The object's axis

TIP Alternately, you can change the values of the position fields in the Axis menu.

- 5 If Auto Key is disabled, click Set Key.
The first vertex on the motion path spline is created.
- 6 Move the positioner to frame 30.
- 7 Move the object to the lower-right corner of the image window.

NOTE If you drag the object to set its second vertex, make sure you click the X-, Y-, or Z-axis and not the centre point where the three axes meet. Dragging from the centre may change the beginning keyframe of the motion path instead of setting a new keyframe.

- 8 Click Set Key.
The second vertex on the motion path spline is set.
- 9 Scrub the positioner to view the motion path.

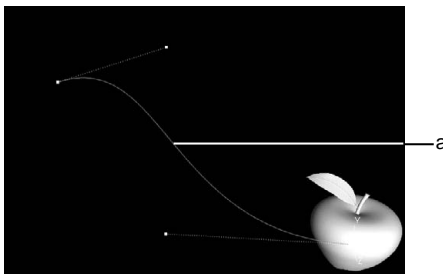

(a) Motion path

- 10 Swipe the bar at the left or right side of the menu to view the Channel Editor.

Once you set the second vertex, the default speed curve is created in the Channel Editor. The keyframes in the speed curve match the vertices in the motion path.

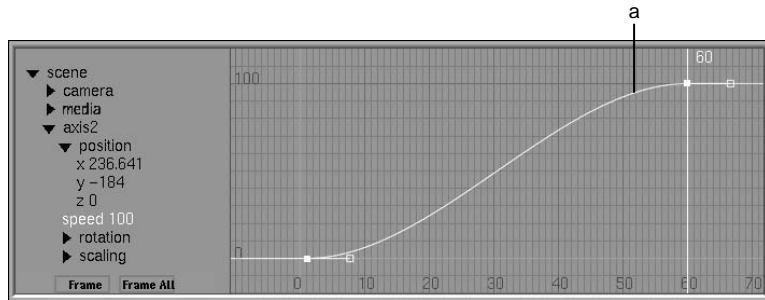

(a) Speed curve

Spline

The spline represents the path of the object, camera, or light source, for example, and consists of alternating colour segments. Each segment represents one frame and indicates the object's speed: the longer the segment, the faster the object is travelling. When the motion path is selected, the segments of the spline are red and blue. When unselected, the segments are blue and green.

The spline is drawn using vertices. Each vertex has a tangent handle that changes the shape of the spline. Changing the shape of the spline between vertices also affects the speed of the animation.

Speed Curve

The speed curve represents the percentage of the path travelled by the animation in time. In other words, the keyframes on the speed curve correspond to the timing values for the keyframes.

The speed curve is created automatically when you draw the motion path. The speed curve controls the timing of the animation. When you create the motion path, a keyframe is added to the speed curve for each vertex on the spline. You can edit the speed curve and adjust the timing of the animation by moving, adding, and deleting vertices from the spline or keyframes in the speed curve. Modifying keyframes on the speed curve does not affect the shape of the motion path spline.

Modifying Motion Path Speed

You control the speed of an object on a motion path by modifying the spline. Modify the spline by moving a vertex to a different location. To slow down an object, break a vertex's tangent handles so that you can reshape the spline and redirect the object. To speed up the object, delete a vertex or two from the spline to make it smoother.

Adding Keyframes to a Motion Path

You can add vertices to a motion path. Adding vertices to a motion path also adds a keyframe to the speed curve. The vertex and keyframe are locked, which means that moving the vertex also affects the keyframe. A locked keyframe is represented by a solid square.

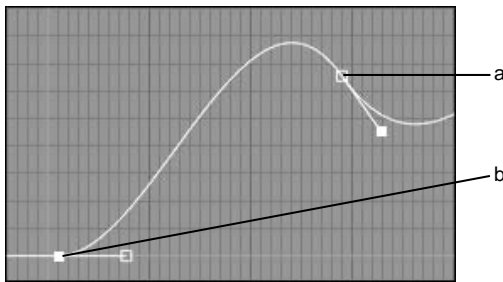

(a) Unlocked keyframe (b) Locked keyframe

You can also add keyframes to the speed curve to change the speed of an animation between vertices on the motion path. Adding a keyframe directly to the speed curve does not add a vertex to the motion path; the keyframe is *unlocked*. You can change the timing of the animation without changing the position of the motion path.

To add keyframes to the speed curve:

- 1 Click Animation.
- 2 In the Channel Editor, select the speed curve.
- 3 From the Edit Mode box, select Add.
The cursor changes indicating you can add keyframes.
- 4 In the Animation Curve window, click the speed curve in the location where you want to add the keyframe.
The added keyframe is *unlocked* and appears as a square outline.

Removing Keyframes from a Motion Path and Speed Curve

You can delete a vertex from a motion path or delete a keyframe from the speed curve. Deleting a vertex from the spline deletes its associated keyframe from the speed curve, affecting both the shape and speed of the animation. Deleting a locked keyframe from the speed curve unlocks its associated vertex on the spline, allowing you to change the shape of the spline without affecting the animation's speed.

To delete a vertex from the motion path:

- 1 Click Animation to display the Channel Editor.
- 2 From the Edit Mode box, choose Select.
Use Select to edit a particular spline when more than one motion path appears in the image window.
- 3 From the Edit Mode box, select Delete.
The cursor changes indicating you can delete keyframes.
- 4 In the image window, click a vertex on the motion path spline.
The keyframe is deleted.

To delete a keyframe from the speed curve:

- 1 Click Animation.
- 2 In the Channel Editor, select the speed curve.
- 3 From the Edit Mode box, select Delete.
The cursor changes indicating you can delete keyframes.
- 4 On the animation curve, click the keyframe you want to delete.
The keyframe is deleted.

Moving a Vertex on a Motion Path

Since you create a motion path in the scene and not in the Channel Editor, you do not have to be positioned at a specific keyframe to move the vertices of a motion path. You can move vertices and tangent handles for any keyframe in the animation.

Moving a locked vertex on the spline changes the position of the object at that frame. A locked keyframe on the speed curve can only be moved along

the horizontal axis (frame number). This changes the frame where the animation reaches a particular point on the spline, but not the shape of the spline. Thus only the animation timing is affected.

To move a vertex on a motion path:

- 1 From the Edit Mode box, select Move.
- 2 Select a vertex on the motion path.
- 3 Drag the vertex or keyframe to its new location.

To move a keyframe on the speed curve:

- 1 From the Edit Mode box, select Move.
- 2 Select a keyframe on the speed curve.
- 3 Drag the keyframe to a new position.

NOTE You cannot move the first and last keyframes vertically because the timing of the animation must begin at 0% and end at 100%.

To move the speed curve in the Animation Curve window:

- 1 From the Edit Mode box, select Translate.
- 2 Select the speed curve.
- 3 Drag the curve horizontally to a new position.

NOTE You cannot translate the first and last keyframes vertically because the timing of the animation must begin at 0% and end at 100%.

Working with Motion Path Tangent Handles

You can also change the speed of an animation by moving the tangent handles of any keyframe on the speed curve. The steeper the slope of the curve, the faster the animation. You can break a tangent handle into two handles and then move each independently to fine-tune the slope of the curve.

Breaking the slope of a keyframe on the speed curve introduces a discontinuity in the speed of an animation. For example, you can have the animation

accelerate until it reaches a given keyframe then have it continue slowly. This change in timing occurs between vertices.

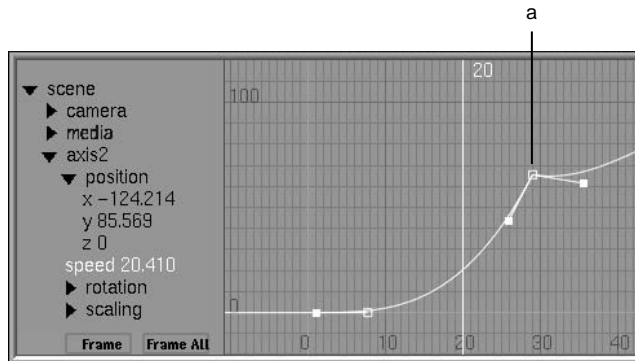

(a) The speed curve makes the apple accelerate rapidly until it reaches frame 29, after which it continues slowly

You can also reverse the animation by creating a curve with a negative slope.

To break the tangents of a keyframe:

- 1 Click Animation.
- 2 In the Channel Editor, select the speed curve.
- 3 From the Edit Mode box, select Break.
- 4 In the Animation Curve window, click a keyframe tangent handle on the speed curve.
It breaks into two separate tangent handles.
- 5 From the Edit Mode box, select Move.
- 6 Adjust the keyframe tangent handles.
- 7 To reset the tangent handle, select Auto from the Edit Mode box and click the tangent handle.

Creating Animation Sequences Across Nodes in Batch

The Universal Channel Editor is available exclusively through Batch. The channels include most nodes present in the Batch schematic, allowing you

to create animations simultaneously for a variety of nodes. You can create animations for multiple nodes without entering and exiting various modules. Using the Universal Channel Editor, you can create animations between nodes so that, for instance, the animation of a garbage mask is synchronized with the animation of a colour correction.

Examples of the animation tasks you can accomplish using the Universal Channel Editor are listed as follows:

- Link cameras between multiple Action nodes, allowing you to synchronize multiple camera views in the scene. Such a task would otherwise be impossible when working in Action alone.
- Use expressions to apply the position, rotation, and scaling data of an axis in Action to control the RGB motion blur of another clip in the Batch process tree. In this way, you can create a complex animation quickly while exploring the benefits of using Batch and expressions in the Universal Channel Editor.
- Use tracking position x and y values from an Action node to control the left and right offset values in a Resize node, allowing you, for example, to create an effect of an animated miniature layer that might appear in a 3D object television set.
- Link colour correction animations to several segments in an assembled clip, allowing you to create a multi-sequence composite—a soft clip. See [Linking Animation to Several Branches](#) on page 2035.

To access the Universal Channel Editor:

- 1 Access the Batch menu.
- 2 In Batch, assemble clips and nodes in the schematic.
See [Assembling a Process Tree](#) on page 1283 to learn how to assemble clips and nodes.
- 3 Click Animation and swipe the bar at the right side of the menu to view the Universal Channel Editor.
All nodes present in the schematic appear in the Universal Channel Editor.

Synchronizing Animations

The possibilities of what you can animate in the Universal Channel Editor are extensive. All nodes and clips that you arrange in the Batch process tree are represented in the Universal Channel Editor—except the Keyer and Modular Keyer, and any node that does not use the Channel Editor. You can, therefore, link channel animations from one node to another to create complex animated effects with precision timing.

The following procedure illustrates how to adjust the timing of RGB gamma channels in a Colour Corrector node and the position of 3D text layers in Action so they are in sync. The idea is to create 3D text layers that fly toward the camera. As each 3D text layer leaves the scene, a colour correction animation creates a flare. The flares must be in sync with both the incoming and outgoing 3D text layers.

You can apply this technique in similar instances where you want dramatic changes in channel values to occur together.

To adjust the timing of RGB gamma channels with the position of 3D text layers:

- 1 In Batch, set up the schematic with clips, a Colour Correct node, and an Action node, as illustrated in the following example.

The image feeding into the Colour Correct node should have high luma values.

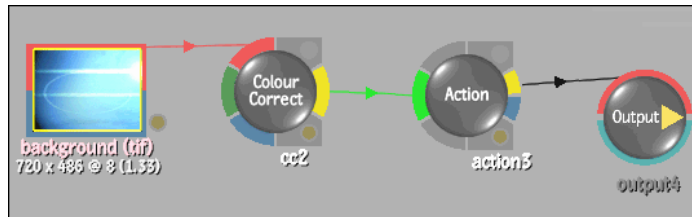

- 2 Click the Action node.
The Action menu appears.
- 3 In Action, add three text layers containing the following words:
 - Tonight
 - at
 - 7 p.m.

- 4 For each 3D text string, select a font, such as Discreet, and set the Size to 800.
For full details on creating 3D text strings, see [Creating 3D Text](#) on page 2300.
- 5 Set the Action setup to 90 frames.
- 6 Go to frame 1, and set the scaling position to 0 to make the first text layer invisible at the first frame.
- 7 Go to frame 30 and set scaling position to 100.
- 8 Adjust the z position until the 3D text flies past the camera.
- 9 Add three extra layers.
- 10 Adjust the transparency and animate motion blur for those layers.
- 11 Copy the Axis node from the first Geom Axis node and use it for the other two text layers.
- 12 Rename the Axis nodes and Geom nodes for easy recognition in the Universal Channel Editor.

An example of what the Action schematic might look like is illustrated as follows.

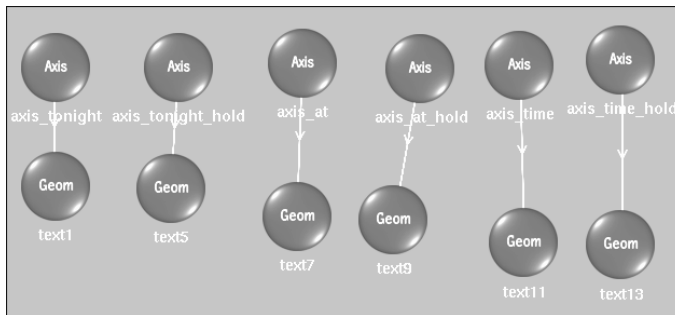

- 13 Set the Channel Editor to Tracks view.
- 14 In Tracks view, offset the axis of each 3D text object as follows:
 - “at” starts at frame 30.
 - “7 p.m.” starts at frame 60.
 - “Tonight” stays where it is as it starts at frame 1.

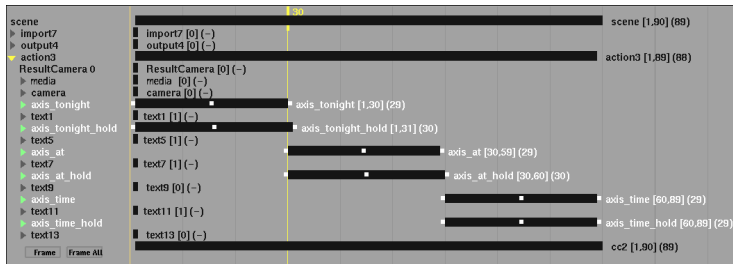

15 Click Play to preview your result.

At frame 1, “Tonight” is scaled at 0 so the text begins to appear at frame 4 or 5, where it flies into the scene and past the camera. At frame 30, the word “at” appears and flies into the scene and past the camera. At frame 60, the words “7 p.m” appears and flies past the camera.

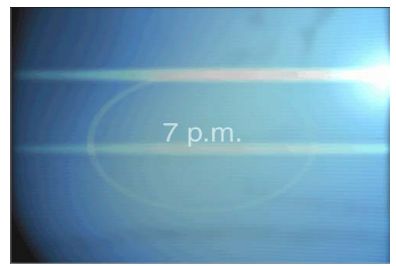
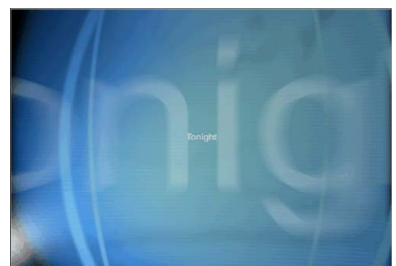

You now have a setup that you can use for the colour correction animation. You want to time the colour correction as each text layer goes past the camera.

16 In the Universal Channel Editor, open the cc folder and then select the red gamma channel.

17 Set the red gamma channel with the following values at the frames indicated:

- Frame 25 = 1
- Frame 29 = 10
- Frame 30 = 1
- Frame 55 = 1
- Frame 59 = 10
- Frame 60 = 1
- Frame 85 = 1
- Frame 89 = 10
- Frame 90 = 1

The gamma changes occur at the same time (30, 60, 90) as the 3D text strings change in the scene.

18 For the first and second gamma keyframes, set the interpolation to Constant prior to the start of the colour correction animation.

19 Copy the red gamma channel data to the green and blue channels using Copy and Link. See the procedure for [Linking Animation to Several Branches](#) on page 2035.

20 Adjust the 3D text position keyframes in the Channel Editor so they are in sync with the gamma keyframes.

The following example illustrates keyframes that are synced up with the gamma channel at frame 30.

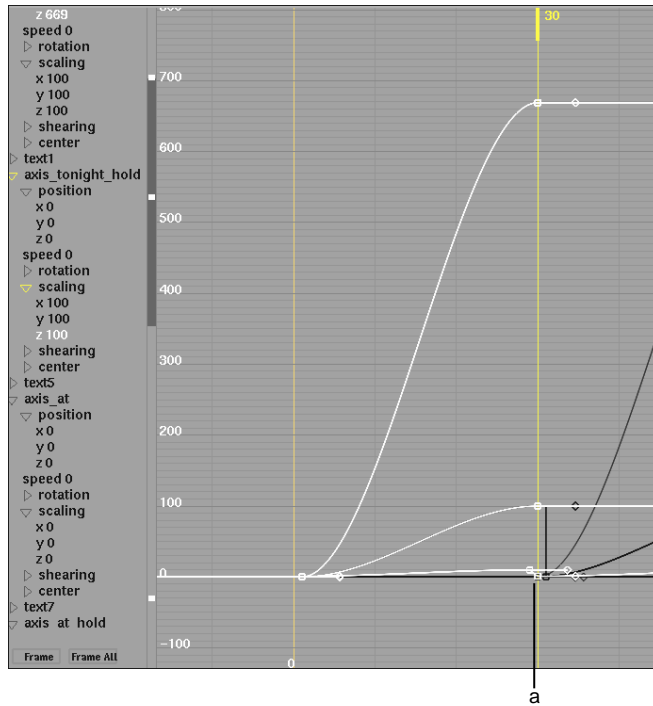

(a) Red gamma channel

TIP To refine the view in the Channel Editor, you can use the Filter controls to display only the channels that are currently animated. See [Showing and Hiding Channels](#) on page 1988.

21 Play the result.

Every time the text flies past the camera, the background should flare to almost white. This all depends on the luma of your background image.

Linking Animation to Several Branches

When you are working with the Batch timeline, you may want to apply the same effect to several segments in an assembled clip. The following procedure illustrates several Colour Correct nodes to which you can link animations. Using Copy and Link, you can link all colour correction channel animations from one Colour Correct node to other Colour Correct nodes.

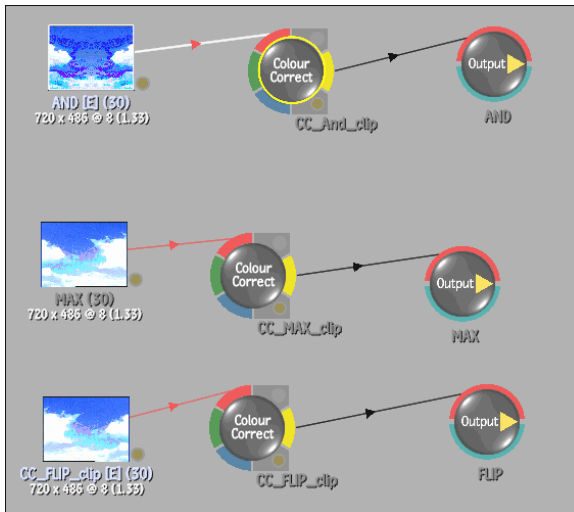

To link colour correction animation to other Colour Corrector nodes:

- 1 In the Batch schematic, arrange Colour Correct nodes according to the effect you want to create.

In this example, three Colour Correct nodes are arranged each with its own output node for use in a complex effect where the sky sequences require the same animated colour effects at different points in the final clip.

- 2 In the Batch schematic, click the Colour Correct node.
- 3 Make sure Auto Key is enabled.
- 4 Click Animation and swipe the bar at the right of the menu.
- 5 In the Universal Channel Editor, modify colour corrector channels at various frames.
- 6 Select the first Colour Correct node and, in the Animation controls, click Copy.
- 7 In the Channel Editor, select the second Colour Correct node and click Link in the Animation controls.

The letter *e* appears next to the second Colour Correct node indicating that an animation expression is applied to the entire node. All channel animations from the first Colour Correct node are applied to the second one.

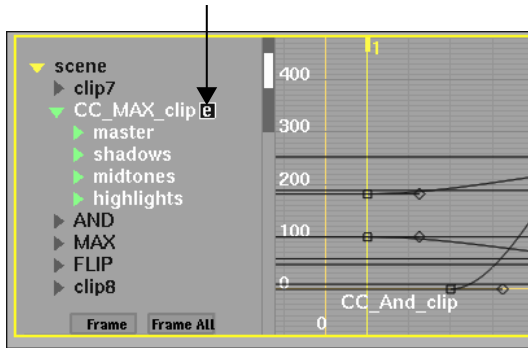

- 8 Do the same for the third Colour Correct node by selecting the third Colour Correct node and then clicking Link.

The copied information is still contained on the clipboard and available for linking again.

Expressions

68

Topics in this chapter:

- [About Expressions](#) on page 2039
- [Working with Expressions in the Channel Editor](#) on page 2043
- [Operator Reference](#) on page 2049
- [Function Reference](#) on page 2051
- [Defining Your Own Functions](#) on page 2076
- [Sample Expression Setups](#) on page 2078

About Expressions

Use expressions to apply animation dynamically to one or more channels. For example, use expressions to easily simulate real-world forces such as gravity, momentum, and centrifugal force. Expressions save time since you can animate one channel, and then refer other channels to the first channel so that the other channels automatically behave in relation to the first one. You can use arithmetic operators, such as addition and multiplication, as well as predefined functions to precisely control the behaviour of an animation.

Expressions are available through all modules that use the Channel Editor. See [Animation](#) on page 1963 for information about animating channels using the Channel Editor.

Expression Content

An expression is composed of numeric values, constants, channel references, or combinations of these used with arithmetic operators. Expressions are calculated from left to right, according to a specific order defined in [Operator Precedence](#) on page 2050.

For example, the following expression contains channel references and multiplies the transparency value of image1 by 2 to affect the transparency of image2 across all keyframes.

Channel	Expression
image2.material.transparency	image1.material.transparency* 2

Vectors

Certain channels such as Position, Rotation, Scale, and Shear are vector based since they represent 3D space and include X-, Y-, and Z-axes. A vector contains three elements that represent the individual components of the channel. Vectors are written using the convention (x, y, z) where x, y, and z represent separate scalar values.

Expressions can either affect the components of a vector individually or collectively. For example, the following expression sets the individual rotation for the x, y, and z axes to 30°, 45° and 90°, respectively.

Channel	Expression
axis1.rotation	(30, 45, 90)

The following expression sets the rotation for axis2 twice that of axis1, affecting the vector collectively.

Channel	Expression
axis2.rotation	axis1.rotation* 2

Functions

Flame includes many predefined functions that can be used to perform calculations in an expression. You pass function-specific values, called *arguments*, and they return another value back to the expression that called

it. A function call in an expression begins with the function name, followed by an opening parenthesis, the arguments for the function separated by commas, and finally a closing parenthesis.

NOTE Function names are case-sensitive.

Arguments for functions can be either scalar values or vectors. When you use a function, make sure that you pass it the correct type of parameter. See [Function Reference](#) on page 2051 for information on the arguments and return values for each function.

You can nest function calls by using the return value of a function as one of the arguments of another function. When a nested function is used as an argument, it must return a value that conforms to the type and range that the argument requires.

You can define your own functions and use them in your expressions just as you would with any of the predefined functions. See [Defining Your Own Functions](#) on page 2076.

Examples

The following expression uses the noise function to create a random positioning effect for axis1.

Channel	Expression
axis1.position.x	noise(frame)*5

The following expression uses the eval function to make the position of axis2 the same as that of axis1, but delayed by 10 frames.

Channel	Expression
axis2.position	eval(axis1.position, frame - 10)

The following expression uses the eval function to make the animation of axis3 the same as that of axis1, but at half the speed.

Channel	Expression
axis3	eval(axis1, frame / 2)

Keywords and Constants

Use the keyword *frame* in an expression to get the value of the current frame number in your animation. This allows you to create an animation by specifying how a value changes over a sequence of frames.

Use the constant *PI* instead of the literal numeric value of π (3.1416...).

NOTE Keywords and constant names are case-sensitive.

Simplified Expressions

A reference to another channel does not have to be fully qualified when it is at the same hierarchical level as the channel to which the expression is being applied. For example, the following simplified expressions are valid when applied to the specified channel. The fully qualified versions of the expressions are also provided.

Channel	Simplified Expression	Fully Qualified Expression
axis1.position.y	x + 50	axis1.position.x + 50
axis1.rotation	position / 2	axis1.position / 2
image1.material.diffuse	specular * 3	image1.material.specular * 3

References to other channels also work when referring to the siblings of any parent. For example, consider the following structure:

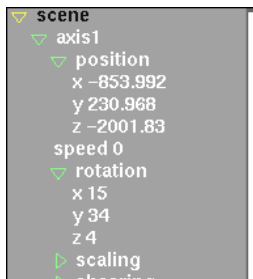

You can apply the expression `position.x` to `axis.rotation.x` because `position` is a sibling of `rotation`, and `rotation` is a parent of `rotation.x`.

Working with Expressions in the Channel Editor

You can apply, modify and view expressions using the Channel Editor. You can use the copy and link functionality to quickly apply basic expressions to multiple channels.

WARNING Expressions override interpolation modes and previously set keyframes for a selected channel.

To apply an expression to a channel:

- 1 In any module menu, click Animation.

The Animation controls appear.

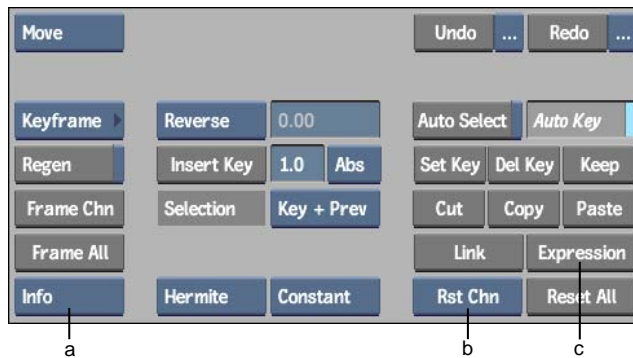

(a) Channel View box (b) Reset Channel button (c) Expressions button

- 2 From the Channel View box, select Info.

Channel information appears in a tabular grid for easier viewing of expressions and channel details. From Info view, you can click the Expressions column heading to sort by expressions and view them more easily.

The image shows a screenshot of the Channel Editor's Info view, displaying a table of channel details. The table has five columns: Channel, Component, Value, # Keys, and Expression. The 'Expression' column header is highlighted, and an arrow points to it from above. The table contains several rows of data, including channels like 'image3.material.transparency', 'image4.material.transparency', 'image5.material.transparency', 'axis1', 'axis1.position', 'axis1.position.x', 'axis1.position.y', and 'axis1.position.z'.

Channel	Component	Value	# Keys	Expression
image3.material.transparency	transparency	0	0	eval(image1.material.trans
image4.material.transparency	transparency	0	0	eval(image1.material.trans
image5.material.transparency	transparency	0	0	eval(image1.material.trans
axis1	axis1			
axis1.position	position			
axis1.position.x	x	0	2	
axis1.position.y	y	132	2	
axis1.position.z	z	0	2	

- 3 Select the channel to which you want to apply an expression.
- 4 In the Animation controls, click Expression (or press).
The Expression field appears below the Channel Editor.

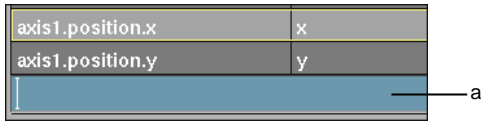

(a) Expression field

- 5 Enter an expression according to the guidelines described in [Operator Reference](#) on page 2049 and [Function Reference](#) on page 2051 and press **Enter**.
The letter 'e' appears next to the channel in the channel hierarchy, indicating that this channel contains an expression.

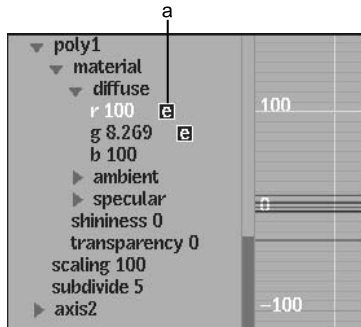

(a) Expression indicator

NOTE Entering an invalid expression will result in the message “Error: Expression: parse error” and the entered expression will not be applied to the channel.

To modify an expression:

- 1 Click Animation to display the Animation controls.
- 2 In the channel hierarchy or Info view, select the expression that you want to edit.
- 3 In the Animation controls, click Expression (or press).
The Expression field appears below the Channel Editor.

- 4 Modify the expression in the field and press Enter.

The modified expression appears in the table.

TIP When you are in the Expression field, you can press **Up** one or more times to retrieve its previous contents. This can be useful if you want to correct an invalid expression that you recently entered.

To remove an expression:

- 1 Click Animation to display the Animation controls.
- 2 In the channel hierarchy or Info view, select the channel with the expression that you want to remove.
- 3 Click Rst Chn to remove the expression.
The channel is reset.

Linking Channels

You can create an expression by linking the behaviour of one channel to another using Copy and Link. You can link different types of channels together. For example, make the scaling of a layer affect the rotation of another layer, or blur a layer by linking it to the position of an axis. Any change that occurs in the position of the axis is reflected dynamically in the layer blur.

To create an expression by linking one channel to another:

- 1 Click Animation to display the Animation controls.
- 2 From the Channel View box, select Info.

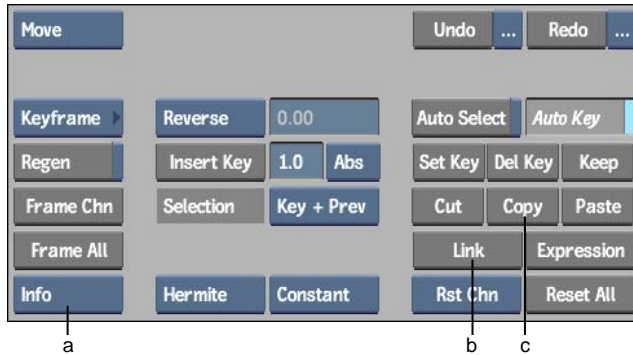

(a) Channel View box (b) Link button (c) Copy button

TIP Enable the Hierarchy View button  to better view the channel hierarchy.

- 3 Select a source channel from which to link and click Copy.
For example, copy the x position of axis1 and link it to the x blur value of a layer.
- 4 Select the destination channel and click Link.
The x blur value of layer1 is linked to the x position value of axis41, so as the position increases, so does the blur. This is shown in the following illustration.

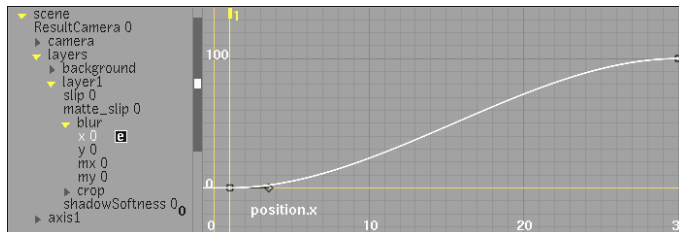

Copying Nodes with Expressions

When working in Action, Keyer or Garbage Masks, if you copy a branch in Schematic view, or append to a setup by loading a second setup, any nodes with the same name as existing ones are renamed with unique names. Likewise,

if expressions are associated with those nodes, the expressions are replicated and the associated channels are renamed to correspond with the new node names. This preserves the integrity of the expression within the copied branch or appended setup.

If you copy a portion of a branch that has expressions associated with it, the expressions related to the copied portion of the branch will be associated with the new copy. Expressions related to uncopied portions of the branch will maintain their association with the original branch.

Cascading Expressions

You can copy a single expression to multiple channels that build on the result in the previous channel using the *SelectionOrder* and *CascadeChannel* keywords. These keywords increment the channel number or name as follows:

- Each instance of *SelectionOrder* increments the channel number.
- Each instance of *CascadeChannel* replaces the occurrence of the channel name with the name of the preceding channel, relative to the order in which the channels are selected.

In general, experiment with the *SelectionOrder* and *CascadeChannel* keywords to determine which results are optimal for your animation.

To apply cascading expressions using *SelectionOrder*:

- 1 Click Animation to display the Animation controls.
- 2 From the Channel View box, select Info.
- 3 Select multiple channels to which you want to apply the cascaded expression, in the desired order.

As you select each channel, the selection order is shown next to the channel name in Info view.

TIP To select a range of channels, click the first channel that you want to include in the range. Then click the last channel to include in the range while holding **Shift**. To add to a range of files, hold **Ctrl** or the stylus button while selecting the channels from the Channel Editor.

- 4 Enter an expression that includes the keyword *SelectionOrder*.

Every instance of the keyword `SelectionOrder` will be substituted in your expression by a different number for each channel, which corresponds to the order in which you selected them.

To animate four channels using `SelectionOrder`:

- 1 In Action, add four axes named `axis1`, `axis2`, `axis3` and `axis4`.
- 2 Animate `axis1.position` by creating a few keyframes.
- 3 Select the channels `axis2.position`, `axis3.position` and `axis4.position` in this order.
- 4 Enter the following expression: `eval(axis1.position, frame - 5 * SelectionOrder)`.

The following expressions are applied:

- `axis1.position`: no expression
- `axis2.position`: `eval(axis1.position, frame - 5 * 1)`
- `axis3.position`: `eval(axis1.position, frame - 5 * 2)`
- `axis4.position`: `eval(axis1.position, frame - 5 * 3)`

To apply cascading expressions using `CascadeChannel`:

- 1 Click Animation to display the Animation controls.
- 2 From the Channel View box, select Info.
- 3 Apply an expression to a base channel to which the other channels will relate.
- 4 Select multiple channels, starting with the base channel, to which you want to apply the cascaded expression, in the desired order.
- 5 Enter an expression that includes the keyword `CascadeChannel`.

The base channel (the first channel selected) will remain unmodified. In the expressions for the other selected channels, every instance of the keyword `CascadeChannel` will be substituted by the name of the channel that preceded it, in the order in which you selected them.

To animate four axes using `CascadeChannel`:

- 1 In Action, add four axes named `axis1`, `axis2`, `axis3` and `axis4`.

- 2 Animate `axis1.position` by creating a few keyframes.
- 3 Select, in this order, the channels `axis1.position`, `axis2.position`, `axis3.position` and `axis4.position`.
- 4 Enter the following expression: `eval(CascadeChannel, frame - 5)`.
The following are applied:
 - `axis1.position`: no expression
 - `axis2.position`: `eval(axis1.position, frame - 5)`
 - `axis3.position`: `eval(axis2.position, frame - 5)`
 - `axis4.position`: `eval(axis3.position, frame - 5)`

NOTE This results in the same animation as the `SelectionOrder` example given above.

Operator Reference

Operators specify a mathematical or logical calculation to be performed between various elements of an expression.

Arithmetic Operators

Use the following arithmetic operators to perform basic mathematical operations.

Operator	Description
+	Addition
-	Subtraction
*	Multiplication
/	Division
%	Modulo (this is a binary operator)
(x,y , z)	Vector where x , y and z are scalar values

Comparison Operators

Use the following operators to compare two values with each other. When two values are compared using these operators, the result is 1 if the comparison is true and 0 if the comparison is false.

Operator	Description
==	Equal to
!=	Not equal to
<	Less than
<=	Less than or equal to
>	Greater than
>=	Greater than or equal to
&&	Boolean AND
	Boolean OR
!	Boolean NOT

Operator Precedence

When you combine several operators in a single expression, the operations are performed in the following order.

Order	Operator	Description
1	!	Boolean NOT
2	-	Negation (as in -1)
3	*, / and %	Multiplication, division, and modulus
4	+ and -	Addition and subtraction
5	<, <=, >, and >=	Comparison
6	== and !=	Equivalence
7	&&	Boolean AND

Order	Operator	Description
8		Boolean OR

When operators with the same precedence are encountered, operators are evaluated from left to right. However, when part of a formula is enclosed in parentheses, it is evaluated first.

Function Reference

You can easily create very complex expressions by using the available functions. This function reference provides detailed information about each function. Function arguments in square brackets are optional. However, if you give a value to an optional argument, you must also give a value to every optional argument before that one.

Animation Functions

Use the following functions to animate channels in a general way.

NOTE Arguments shown in square brackets are optional. For example, in the syntax of the align function, the options [AxisToAlign] and [BankingAngle] are optional.

align

Returns a rotation vector such that a designated axis of an object is aligned with the direction of the object's movement. You can also bank the rotation around the axis. The result should usually be assigned to a rotation channel.

Syntax: align(PosToFollow, [AxisToAlign], [BankingAngle])

Arguments: ■ *PosToFollow* is the vector representing the channel to align on, typically an animated position.

 ■ *AxisToAlign* is the vector representing the axis with which to align, by default the X-axis (1,0,0).

 ■ *BankingAngle* is the angle in radians by which to rotate the result about the AxisToAlign (performs banking). If the BankingAngle argument is specified, the AxisToAlign argument must also be specified.

Example: `align(axis.position, (0,0,1), frame * PI / 8)` returns a rotation vector that points the object's Z-axis in the direction of its motion while the rest of the axis rotates along this axis.

lookat

Returns a rotation vector based on an object's position that points it towards a second moving object. The result should usually be assigned to a rotation channel.

Syntax: `lookat(TargetPos, ObserverPos, [AlignVector], [UpVector])`

- Arguments:
- `TargetPos` is the vector of an object's position channel that you want the rotation vector to point towards.
 - `ObserverPos` is the vector of the position channel from which you are looking.
 - `AlignVector` is the vector of the direction that you want to have looking at the target, by default the Z-axis (0,0,1).
 - `UpVector` is the vector of the direction that you want to be pointing upwards, by default the Y-axis (0,1,0). The `UpVector` should be set to a different vector than the `AlignVector`. If the `UpVector` argument is specified, the `AlignVector` argument must also be specified.

-
- Examples:
- `lookat(followed_axis.position, follows_axis.position)` returns the rotation vector required so that `follows_axis` points its Z-axis towards `followed_axis`.
 - `lookat(followed_axis.position, follows_axis.position, (0,1,0),(1,0,0))` returns the rotation vector required so that `follows_axis` points its Y-axis towards `followed_axis`, with its X-axis pointing upwards.
-

eval

Returns the value of a given expression at another point in time.

Syntax: `eval(Expression, FrameNumber)`

- Arguments:
- `Expression` is the expression to be evaluated. This can be any valid channel value.
 - `FrameNumber` is the frame to simulate when evaluating the given expression.
-

- Examples:
- `eval(axis1.position.x, 5)` returns the value of `axis1.position.x` at frame 5.
 - `eval(axis1.position, frame - 10)` returns the `axis1.position` vector at 10 frames behind the current frame.
 - `eval(axis1, frame / 2)` returns the entire `axis1` channel at half the normal speed.
-

if

Returns one of two values based on the result of a conditional test. You can nest multiple functions inside each other to handle multiple results.

Syntax: `if(Condition, TrueValue, FalseValue)`

- Arguments:
- `Condition` is any channel or expression. When comparison operators are used, a true expression evaluates to 1 and a false expression evaluates to 0. See [Comparison Operators](#) on page 2050.
 - `TrueValue` is the value to be returned for any non-zero result.
 - `FalseValue` is the value to be returned if `Condition` evaluates to 0.
-

- Examples:
- `if(axis.position.y >= 100, 5, -5)` returns 5 when `axis.position.y` is greater than or equal to 100, and -5 otherwise.
 - `if(frame < 10 || frame > 20, 100, 200)` returns 100 when the current frame is less than 10 or above 20, and 200 otherwise.
 - `if(axis.position.x, 6, 7)` returns 6 when `axis.position.x` is something other than 0, and 7 when it is 0.
 - `if(axis.position.x == 100 && axis.position.y != 200, 8, 9)` returns 8 when `axis.position.x` is 100 and `axis.position.y` is not 200, and 9 otherwise.
 - The next four examples all equivalently return 5 when neither `axis.position.x` nor `axis.position.y` are greater than or equal to 0, and -5 otherwise.

```
if(!(axis.position.x >= 0 || axis.position.y >= 0), 5, -5)
```

```
if(!(axis.position.x >= 0) && !(axis.position.y >= 0), 5, -5)
```

```
if(axis.position.x < 0 && axis.position.y < 0, 5, -5)
```

```
if(axis.position.x < 0, if(axis.position.y < 0, 5, -5), -5)
```

ease

Returns a number from 0 to 1 representing a smooth S-curve transition between a given range of frames. All frames before the start frame are assigned 0 and all frames after the end frame are assigned 1. A start weight and end weight specify how the S-curve is formed.

Syntax: `ease(StartFrame, EndFrame, [StartWeight], [EndWeight])`

- Arguments:
- StartFrame and EndFrame are the frames at which the transition starts and ends respectively.
 - StartWeight and EndWeight are numbers that specify how curvature is distributed at the start and end of the curve respectively. To get an S-curve, their sum should be less than 1, otherwise a square curve will result. In addition, if either of these two arguments are specified, the other must also be specified.

-
- Examples:
- `ease(10, 50) * 100` returns a standard S-curve from 0 to 100 between frames 10 and 50.
 - `80 - ease(1, 40) * 20` returns a standard S-curve from 80 to 60 between frames 1 and 40.
 - `ease(1, 30, 0.2, 0.2) * 50 + 10` returns a tight S-curve from 10 to 60 between frames 1 and 30.
 - `ease(10, 80) * 150` yields the following curve:

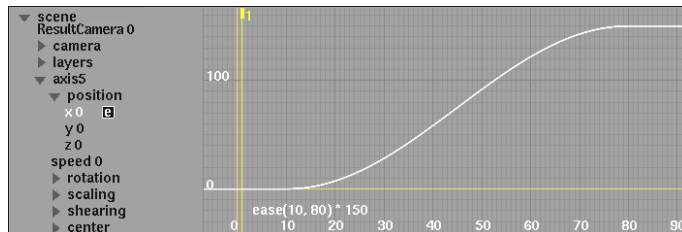

- `ease(10, 80, 0.2, 0.2) * 150` yields the following curve:

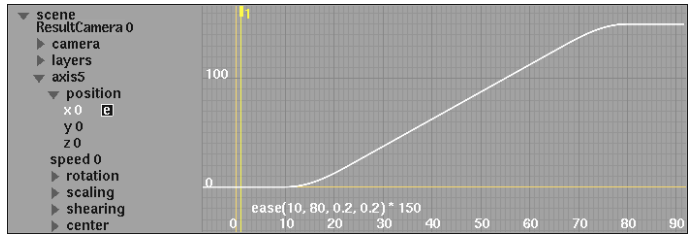

bell

Returns a set of values representing a bell (normal distribution) curve over time. You can specify the centre frame number and height and width characteristics of the curve.

Syntax: `bell(CentreFrame, Height, Width)`

- Arguments:
- CentreFrame is the frame number at which the bell curve will reach its maximum height.
 - Height is the maximum height of the bell curve.
 - Width specifies the horizontal distribution of the curve.

- Examples:
- `bell(10, 100, 3)` returns a bell curve centred around frame 10 with a maximum height of 100 and a width distribution of 3.
 - `bell(50, 150, 10)` yields the following curve:

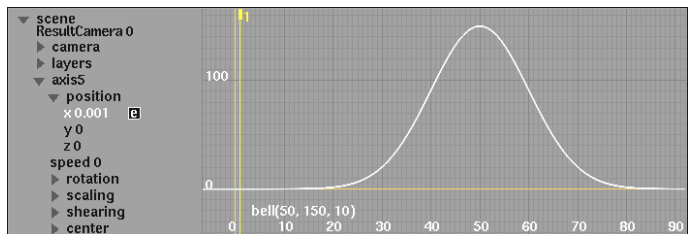

- `bell(50, 150, 20)` yields the following curve:

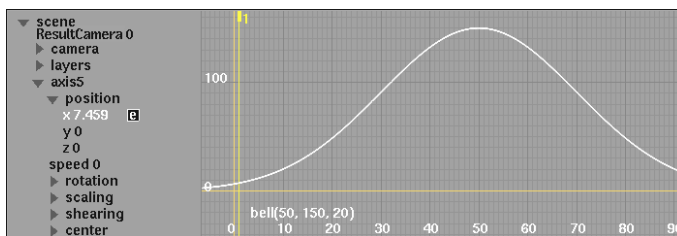

Slip Functions

Use the following functions to slip the starting frame of a clip backwards or forwards using the slip channel. In effect, the displayed frame in a layer's clip will be the animation's current frame number plus the slip value. For example, a slip value of -15 holds the clip at the first frame and repeats it 15 times before the clip begins. In this way, you can create a freeze frame effect with one layer while animating another layer. A slip value of 10 begins the clip at frame 11. See [Modifying Surfaces](#) on page 2179.

NOTE Slip functions are actually implemented as user-defined functions in the functions file. See [Defining Your Own Functions](#) on page 2076.

pingpong

Returns a slip value that makes a clip continuously cycle forwards and backwards. The result should usually be assigned to the slip channel of a layer.

Syntax: `pingpong(length)`

Arguments: ■ `length` is the number of frames to display before starting to play backwards. This is usually the length of the original clip.

Examples: ■ `pingpong(10)` returns a slip value that makes a clip continuously play in a forward and backward cycle from frame 1 to frame 10.

 ■ `pingpong(30)` yields the following curve:

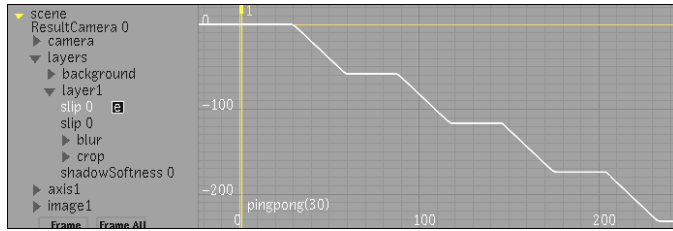

repeat

Returns a slip value that makes a clip continuously repeat forwards. The result should usually be assigned to the slip channel of a layer.

Syntax: `repeat(length)`

Arguments: ■ length is the number of frames to display before repeating from the beginning. This is usually the length of the original clip.

Examples: ■ `repeat(10)` returns a slip value that makes a clip repeat forwards from frame 1 to frame 10.
 ■ `repeat(30)` yields the following curve:

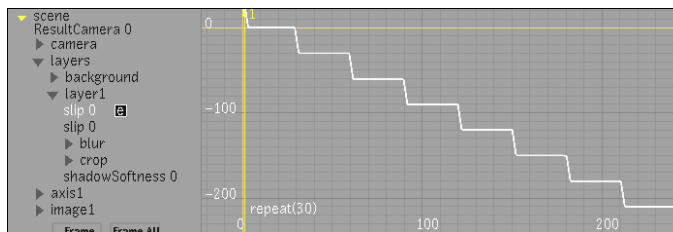

repeatback

Returns a slip value that makes a clip continuously repeat backwards. The result should usually be assigned to the slip channel of a layer.

Syntax: `repeatback(length)`

Arguments: ■ length is the number of frames from the beginning to display backwards before repeating. This is usually the length of the original clip.

- Examples:
- `repeatback(10)` returns a slip value that makes a clip repeat backwards from frame 10 to frame 1.
 - `repeatback(30)` yields the following curve:

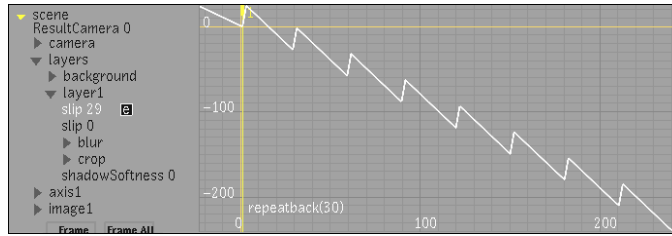

frametoslip

Returns a slip value that makes a clip display at a given timebar frame. If the given frame number is constant, the resulting clips will freeze at that frame. The result should usually be assigned to the slip channel of a layer.

Syntax: `frametoslip(TimebarFrame)`

Arguments: ■ `TimebarFrame` is the timebar frame at which to display the clip.

- Examples:
- `frametoslip(10)` returns a slip value that makes a clip freeze at frame 10.
 - `frametoslip(frame / 2)` returns a slip value that makes a clip display at half the normal speed.
 - `frametoslip(14)` yields the following curve:

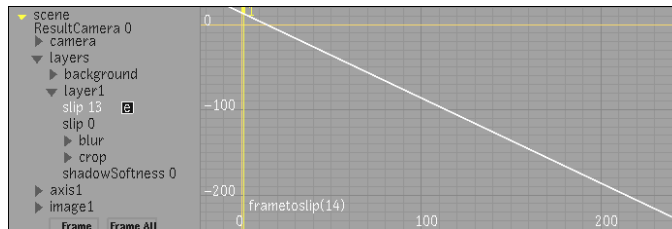

Simple Mathematical Functions

The following functions are useful for performing various simple mathematical calculations.

abs

Returns the absolute value of a given number. The absolute value is the positive value of any number.

Syntax: `abs(Number)`

Arguments: ■ Number is the number of which you want the absolute value.

Examples: ■ `abs(3)` returns 3.
 ■ `abs(-3)` returns 3.

sign

Returns the sign of a given number. The sign function returns 1 if the number is above or equal to zero, and returns -1 if less than zero.

Syntax: `sign(Number)`

Arguments: ■ Number is the number of which you want the sign.

Examples: ■ `sign(5)` returns 1.
 ■ `sign(0)` returns 1.
 ■ `sign(-0.001)` returns -1.

pow

Returns a number raised to the power of an exponent.

Syntax: `pow(Number,Power)`

Arguments: ■ Number is the base number to be raised.
 ■ Power is the exponent to which the base number is raised.

Examples: ■ `pow(3, 2)` returns 9.

- `pow(4, 3)` returns 64.
- `pow(5, 0)` returns 1.
- `pow(-2.5, 4)` returns 39.0625.

sqrt

Returns the square root of a given number.

Syntax: `sqrt(Number)`

Arguments: ■ Number is the non-negative number of which you want the square root.

Examples: ■ `sqrt(25)` returns 5.
 ■ `sqrt(abs(-25))` returns 5.
 ■ `sqrt(0)` returns 0.

max

Returns the larger of two given numbers.

Syntax: `max(Number1, Number2)`

Arguments: ■ Number1 and Number2 are numbers of which you want to find the maximum value.

Examples: ■ `max(5.9, 8.1)` returns 8.1.
 ■ `max(-14, -32)` returns -14.
 ■ `max(axis1.position.x, axis2.position.x)` returns the larger of `axis1.position.x` or `axis2.position.x`.

min

Returns the smaller of two given numbers.

Syntax: `min(Number1, Number2)`

Arguments: ■ Number1 and Number2 are numbers of which you want to find the minimum value.

-
- Examples:
- `min(5.9, 8.1)` returns 5.9.
 - `min(-14, -32)` returns -32.
 - `min(axis1.position.x, axis2.position.x)` returns the smaller of `axis1.position.x` or `axis2.position.x`.
-

mod

Returns the integer remainder from dividing one number by another. This function is useful for repeating an animation every given number of frames.

Syntax: `mod(Number, Divisor)`

- Arguments:
- Number is the number to divide.
 - Divisor is the number by which you want to divide Number.
-

- Examples:
- `mod(8, 3)` returns 2 because 8 divided by 3 is 2 with 2 as the remainder.
 - `mod(-8, 3)` returns -2.
 - `mod(8, -3)` returns 2.
 - `mod(-8, -3)` returns -2.
 - `mod(7.5, 2.25)` returns 0.75.
 - `mod(frame, 20) * 5` yields the following curve:

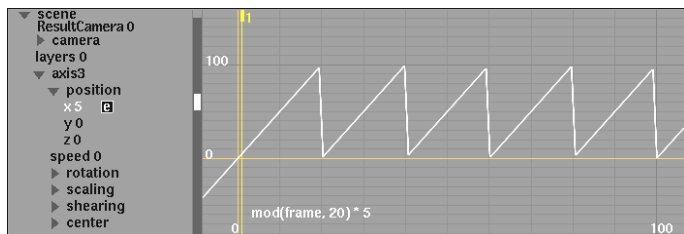

Random Number Functions

Use the following functions to create curves based on random values.

rand

Returns a random value between -1 and 1, based on the value used as an argument, called the *seed*. Using the same seed in the rand function for multiple channels produces the exact same results. To create completely random results, use the true rand function.

Syntax: `rand(Seed)`

Arguments: ■ Seed is the value used to generate the random return value. This is usually set to a changing value such as the current frame number.

Examples: ■ `rand(frame % 10) * 50 + 50` returns a set of random values between 0 and 100 that repeats every 10 frames.

 ■ `rand(frame) * 100` returns a random value between -100 and 100 for every frame in the animation. The following curve shows the result of this function:

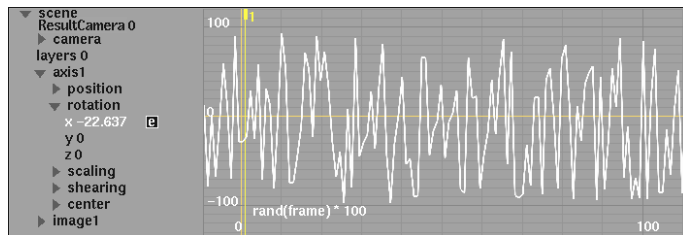

truerand

Returns a truly random value between two given numbers. The sequence of returned values will constantly change, never reproducing past results.

Syntax: `truerand(Low, High)`

Arguments: ■ Low and High are the upper and lower bounds, respectively, of the random number to generate.

Example: ■ `truerand(-5.5,10.8)` returns a truly random value between -5.5 and 10.8.

noise

Returns a random value between -1 and 1, based on a given vector. If the parameter varies smoothly, this function will return a continuously changing value that also varies smoothly.

Syntax: noise(Position)

Arguments: ■ Position is a vector used as a seed for the returned random value.

- Examples: ■ noise(frame) * 5 returns a continuous random value between -5 and 5.
- (noise(axis1.position) + 1) / 2 * 100 returns a continuous random value between 0 and 100.
- noise(axis1.position) * 100 yields the following curve:

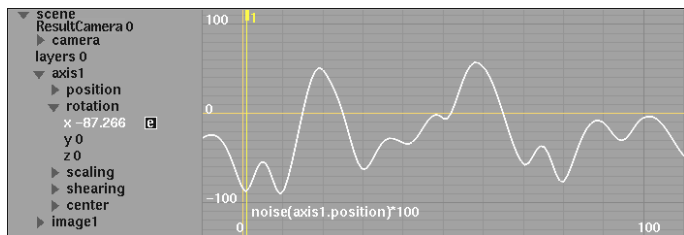

noise3

Returns a random vector for all elements in a vector between -1 and 1. If the parameter varies smoothly, this function will return a vector of continuously changing values that also vary smoothly.

Syntax: noise3(Position)

Arguments: ■ Position is a vector used as a seed for the returned random vector.

- Examples: ■ noise3(frame) * 5 returns a vector of continuous random values between -5 and 5.
- (noise3(axis1.position) + 1) / 2 * 100 returns a vector of continuous random values between 0 and 100.
- noise3(axis1.position) * 100 returns the following three curves:

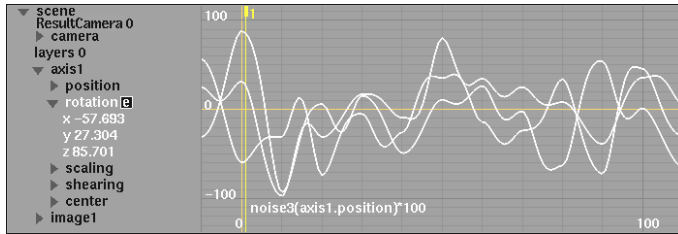

fnnoise

Returns a random value between -1 and 1, based on a given vector. If the parameter varies smoothly, this function will return a continuously changing value that also varies smoothly to a fractal pattern. This function is similar to the noise function, but it applies a fractal pattern to the result.

Syntax: `fnnoise(Position)`

Arguments: ■ Position is a vector used as a seed for the returned random value.

- Examples:
- `fnnoise(frame) * 5` returns a continuous random value between -5 and 5.
 - `(fnnoise(axis1.position) + 1) / 2 * 100` returns a continuous random value between 0 and 100.
 - `fnnoise(axis1.position) * 100` yields the following curve:

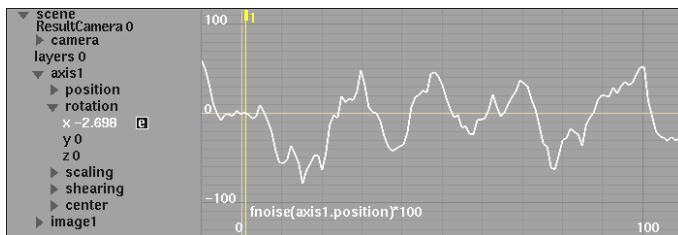

turbulence

Returns a random value between -1 and 1, based on a given vector and with the ability to control the level of smoothness for the resulting curve.

Syntax: `turbulence(Position, Level)`

- Arguments:
- Position is a vector used as a seed for the returned random value.
 - Level is a positive integer where the greater the value, the greater the jitter applied to the resulting curve. If this argument is set to a value less than 1, the level will be treated as if 1 were used. If it is set to a number with a fractional component, the number will be rounded down to the nearest integer.

Examples: ■ `turbulence(axis1.position, 1) * 100` yields the following curve:

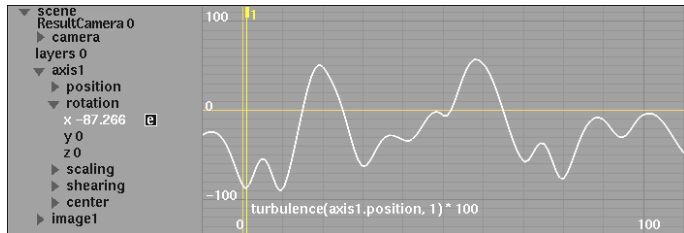

■ `turbulence(axis1.position, 8) * 100` yields the following curve:

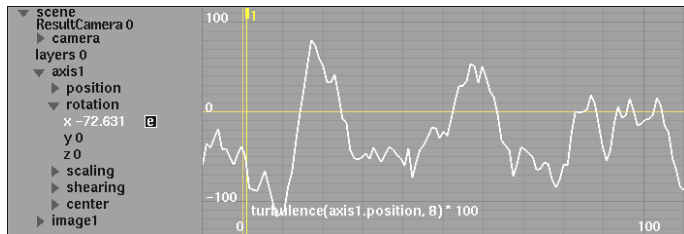

turbulence3

Returns a random vector for all elements in a vector between -1 and 1, along with the ability to control the smoothness of the resulting curve. If the position parameter varies smoothly, this function will return a vector of continuously changing values that also vary smoothly.

Syntax: `turbulence3(Position, Level)`

- Arguments:
- Position is a vector used as a seed for the returned random vector.
 - Level is a positive integer used to control the level of jitter of the resulting curve. If this argument is set to a value less than 1, the level will be treated as if 1 were used. If it is set to a number with a frac-

tional component, the number will be rounded down to the nearest integer.

- Examples:
- `turbulence3(axis1.position, 1) * 100` returns the following three curves:

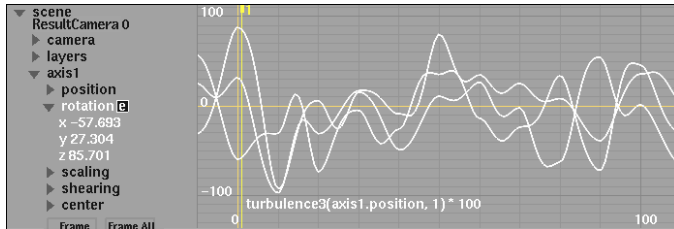

- `turbulence3(axis1.position, 8) * 100` returns the following three curves:

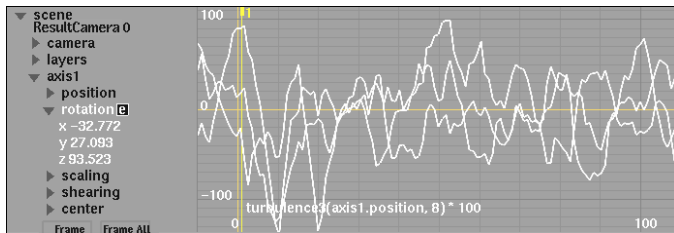

Rounding Functions

The following functions are useful for performing various rounding calculations.

NOTE Although you can use these rounding functions as you would any other predefined function, they are actually implemented as user-defined functions in the functions file provided with the Flame installation. See [Defining Your Own Functions](#) on page 2076.

round

Returns a number rounded to the nearest integer.

Syntax: `round(Number)`

Arguments: ■ Number is the number to round.

Examples: ■ `round(2.8)` returns 3.
■ `round(-2.8)` returns -3.
■ `round(2.3)` returns 2.

ceil

Rounds a number up to the next integer value regardless of its value.

Syntax: `ceil(Number)`

Arguments: ■ Number is the number to round up.

Examples: ■ `ceil(2.8)` returns 3.
■ `ceil(-2.8)` returns -2.
■ `ceil(4)` returns 4.

floor

Rounds a number down to the nearest integer regardless of its value.

Syntax: `floor(Number)`

Arguments: ■ Number is the number to round down.

Examples: ■ `floor(2.3)` returns 2.
■ `floor(-2.3)` returns -3.
■ `floor(4)` returns 4.

trunc

Returns the integer value of a number by truncating its fractional part.

Syntax: `trunc(Number)`

Arguments: ■ Number is the number that you want to truncate.

- Examples:
- `trunc(3.8)` returns 3.
 - `trunc(-3.8)` returns -3.
 - `trunc(PI)` returns 3.
-

Trigonometric Functions

The following functions are useful for working with angles and performing various trigonometric calculations.

degrees

Converts angle units from radians into degrees.

Syntax: `degrees(Angle)`

Arguments: ■ Angle is the angle in radians that you want to convert.

- Examples:
- `degrees(PI)` returns 180.
 - `degrees(PI/2)` returns 90.
-

radians

Converts angle units from degrees into radians.

Syntax: `radians(Angle)`

Arguments: ■ Angle is the angle in degrees that you want to convert.

Example: ■ `radians(225)` returns 3.927 ($5 \cdot \text{PI}/4$).

cos

Returns the cosine of a given angle.

Syntax: `cos(Angle)`

Arguments: ■ Angle is the angle in radians of which you want the cosine.

- Examples:
- $\cos(0)$ returns 1.
 - $\cos(\pi / 3)$ returns 0.5.
 - $\cos(\text{frame} / 10) * 100$ yields the following curve:

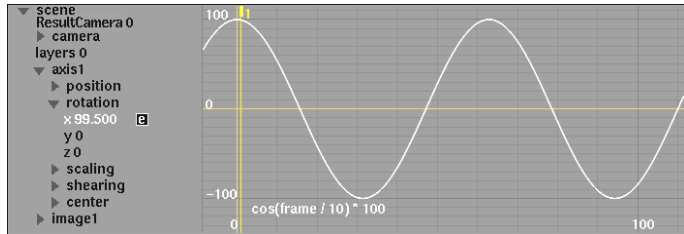

sin

Returns the sine of a given angle.

Syntax: $\sin(\text{Angle})$

Arguments: ■ Angle is the angle in radians of which you want the sine.

- Examples:
- $\sin(0)$ returns 0.
 - $\sin(\pi / 6)$ returns 0.5.
 - $\sin(\text{frame} / 10) * 100$ yields the following curve:

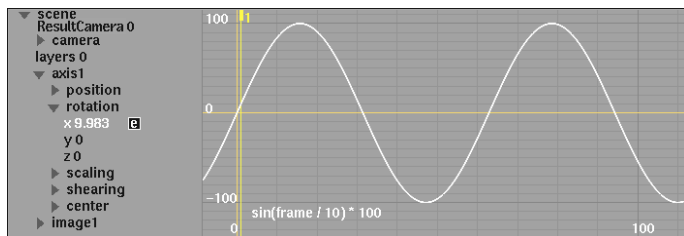

tan

Returns the tangent of a given angle.

Syntax: $\tan(\text{Angle})$

Arguments: ■ Angle is the angle in radians of which you want the tangent.

- Examples:
- $\tan(0)$ returns 0.
 - $\tan(\pi / 4)$ returns 1.
 - $\tan(\pi / 3)$ returns 1.7321.
 - $\tan(\text{frame} / 10) * 50$ yields the following curve:

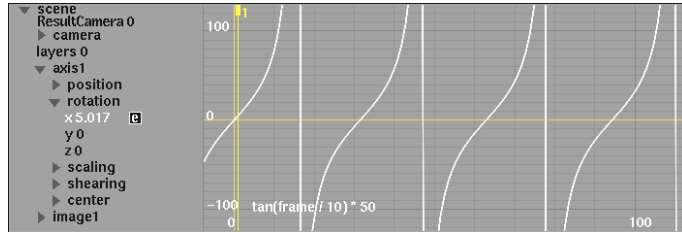

acos

Returns the arccosine—the inverse function of the cosine—of a given number. The returned angle is given in radians within the range 0 to π .

Syntax: `acos(Number)`

Arguments: ■ Number is the cosine of the angle you want and must be between -1 and 1.

- Examples:
- `acos(0.5)` returns 1.0472 ($\pi/3$ radians).
 - `degrees(acos(0.5))` returns 60.

asin

Returns the arcsine—the inverse function of the sine—of a given number. The returned angle is given in radians within the range $-\pi/2$ to $\pi/2$.

Syntax: `asin(Number)`

Arguments: ■ Number is the sine of the angle you want and must be between -1 and 1.

- Examples:
- `asin(0.5)` returns 0.5236 ($\pi/6$ radians).
 - `degrees(asin(0.5))` returns 30.

atan

Returns the arctangent—the inverse function of the tangent— of a given number. The returned angle is given in radians within the range $-\pi/2$ to $\pi/2$.

Syntax: `atan(Number)`

Arguments: ■ Number is the tangent of the angle you want.

Examples: ■ `atan(1)` returns 0.7854 ($\pi/4$ radians).
 ■ `degrees(atan(1))` returns 45.

atan2

Returns the arctangent of y/x , using the signs of both arguments to determine the quadrant of the return value. The arctangent is the angle from the origin to the vector (x,y) . The returned angle is given in radians within the range $-\pi$ to π .

Syntax: `atan2(x, y)`

Arguments: ■ x and y are the components of the vector to be used in the function.

Examples: ■ `atan2(1, 1)` returns 0.7854 ($\pi/4$ radians).
 ■ `atan2(-1, -1)` returns -2.3562 ($-3\pi/4$ radians).
 ■ `atan2(1, 0)` returns 1.5708 ($\pi/2$ radians).
 ■ `degrees(atan2(1,1))` returns 45.

Vector Functions

Use the following functions for performing various vector-related operations.

length

Returns the euclidean length (magnitude) of a given vector. The euclidian length is equivalent to the expression $\sqrt{(\text{pow}(\text{Vector.x}, 2) + \text{pow}(\text{Vector.y}, 2) + \text{pow}(\text{Vector.z}, 2))}$.

Syntax: `length(Vector)`

Arguments: ■ Vector is the vector of which you want the euclidean length.

Examples: ■ `length((2, 0, 0))` returns 2.
■ `length((1, 1, 0))` returns 1.4142.
■ `length((-1, -1, -1))` returns 1.7321.
■ `length(axis1.position - axis2.position)` returns the distance between axis1 and axis2.

dot

Returns the scalar dot-product of two given vectors. The *dot-product* is the product of the lengths of two vectors and the cosine of the angle between them. If the two vectors are at a right angle (90 degrees), their dot-product is 0.

If the product of their lengths equals 1 and they point in opposite directions (180 degrees), their dot-product is -1. The dot-product is equivalent to the expression $V1.x * V2.x + V1.y * V2.y + V1.z * V2.z$.

Syntax: `dot(V1, V2)`

Arguments: ■ V1 and V2 are the vectors of which you want the dot-product.

Examples: ■ `dot((1, 1, 0), (0, 0, 1))` returns 0.
■ `dot((2, 0, 0), (0.5, 0, 0))` returns 1.
■ `dot((0, 2, 0), (0, -0.5, 0))` returns -1.
■ `dot((2, 0, 1), (4, 5, 5))` returns 13.

cross

Returns the vector cross-product of two given vectors. The cross-product is the vector perpendicular to the plane containing the two vectors. In effect, there will be a right angle between the returned vector and the first given vector, as well as a right angle between the returned vector and the second given vector. The length of the resulting vector is equal to the product of the two vectors and the sine of the angle between them. The cross-product is

equivalent to the vector $(V1.y * V2.z - V1.z * V2.y, V1.z * V2.x - V1.x * V2.z, V1.x * V2.y - V1.y * V2.x)$.

Syntax: `cross(V1, V2)`

Arguments: ■ V1 and V2 are the vectors of which you want the cross-product.

Examples: ■ `cross((1, 0, 0), (0, 1, 0))` returns (0, 0, 1).
■ `cross((1, 1, 0), (0, 1, 1))` returns (1, -1, 1).
■ `cross((2, 0, 0), (0, 0.5, 0))` returns (0, 0, 1).

Logarithmic Functions

Use the following functions for performing various logarithmic calculations.

log

Returns the natural logarithm of a given number. The log function is the inverse of the exp function.

Syntax: `log(Number)`

Arguments: ■ Number is the positive number of which you want the natural logarithm.

Examples: ■ `log(1)` returns 0.
■ `log(2)` returns 0.6931.
■ `log(exp(5))` returns 5.
■ `log(256) / log(2)` returns 8.
■ `log(frame / 20) * 50` yields the following curve:

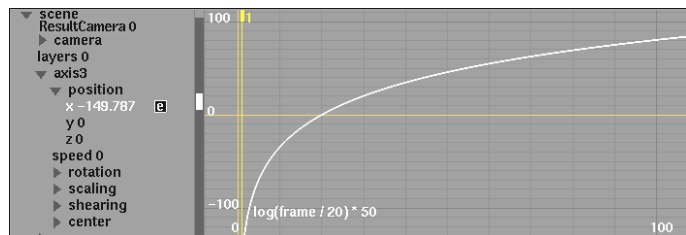

log10

Returns the base-10 logarithm of a given number.

Syntax: `log10(Number)`

Arguments: ■ Number is the positive number of which you want the base-10 logarithm.

Examples: ■ `log10(1)` returns 0.
■ `log10(10)` returns 1.
■ `log10(100)` returns 2.

log1p

Returns the natural logarithm of 1 plus a given number. The `log1p` function is the inverse of the `expm1` function.

Syntax: `log1p(Number)`

Arguments: ■ Number is the positive number less 1 of which you want the natural logarithm.

Examples: ■ `log(0)` returns 0.
■ `log(1)` returns 0.6931.
■ `log1p(expm1(5))` returns 5.
■ `log1p(frame)` returns the equivalent of `log(1+frame)`.
■ `log1p(frame / 20) * 50` yields the following curve:

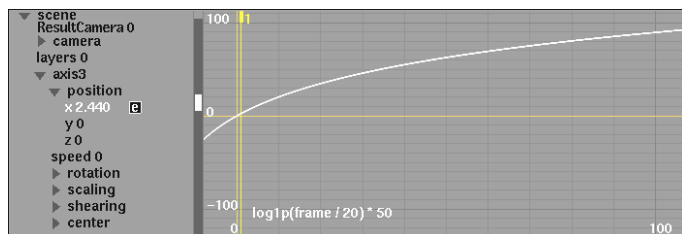

exp

Returns the constant e (the base of the natural logarithm) raised to the power of a given number. The exp function is the inverse of the log function.

Syntax: `exp(Number)`

Arguments: ■ Number is the exponent applied to the base e .

- Examples: ■ `exp(0)` returns 1.
■ `exp(1)` returns 2.7182.
■ `exp(2)` returns 7.3890.
■ `exp(log(5))` returns 5.
■ `exp(frame / 20) * 5` yields the following curve:

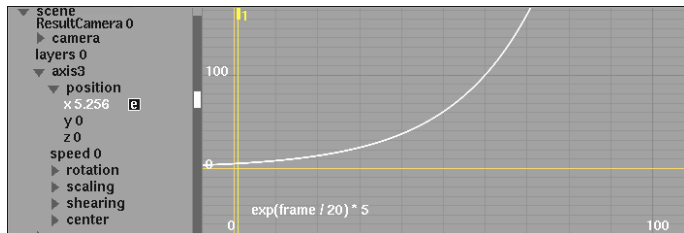

expm1

Returns the constant e (the base of the natural logarithm) raised to the power of a given number, minus 1. The expm1 function is the inverse of the log1p function.

Syntax: `expm1(Number)`

Arguments: ■ Number is the exponent applied to the base e .

- Examples: ■ `expm1(0)` returns 0.
■ `expm1(1)` returns 1.7182.
■ `expm1(2)` returns 6.3890.
■ `expm1(log1p(5))` returns 5.
■ `expm1(frame)` returns the equivalent of `exp(frame) - 1`.
-

Defining Your Own Functions

Flame allows you to define your own functions and use them like any other predefined function. By defining functions in terms of existing functions, you can simplify the creation of complex expressions in your animations.

NOTE You should have a good understanding of how to use functions in expressions before you define your own functions.

The Functions File

There are two text files in which you can enter user-defined functions:

- Project-specific file: `/usr/discreet/project/<user name>/expressions/userfun.expressions`
- Template file: `/usr/discreet/<product home>/expressions/userfun.expressions`

To define a function for your current project, add it to the project-specific file. Modifying this file will affect only that project and not any other existing or future projects.

If you decide that you want to use the function in future projects, copy it from the project-specific file to the template file. When you create a project, the template file is copied to your project directory as the project-specific file for that new project. This functionality allows you to modify user-defined functions in new projects without affecting the behaviour of your animations in older projects.

To edit the functions file:

- 1 Open a command window.
- 2 Use the mouse to position the cursor in the shell and type one of the following commands, depending on which file you want to edit.

Enter:	To:
<code>nedit /usr/discreet/project/<user name>/expressions/userfun.expressions</code>	Edit the project-specific file.

Enter:

To:

```
nedit /usr/discreet/<product
home>/expressions/userfun.expres-
sions
```

Edit the template file.

The functions file opens in a shell and you can edit it as you would any other text file.

Defining a Function

A function is composed of a function name, with the list of arguments, and the expression that forms its definition. You start a function by its name, followed by an opening parenthesis, the arguments for the function separated by commas, and finally a closing parenthesis. The following rules apply for function and argument names:

- The first character of a function name must be a letter, and subsequent characters can only contain letters or numbers. For example, `sin100` is a valid function name, although `100sin` is not.
- The first character of an argument must be a dollar sign (`$`), the second character must be a letter, and subsequent characters can only contain letters or numbers. For example, `$arg1` is a valid argument name, although `$1` and `arg3` are not.
- Function names and arguments are case sensitive, meaning that lowercase and uppercase make a difference.

The function name and its definition are separated by a colon (`:`). The definition itself can be any valid expression, except that channel names are not accepted since user-defined expressions are not related to any particular setup. In the definition, the arguments can appear, complete with the dollar sign preceding it. Finally, the definition must end with a semicolon (`;`) and it can span several lines.

NOTE Errors in the functions file will be reported when it is first read. This file is read every time that an unknown function is used in an expression.

Comments

You can include comments in the functions file by starting the line with a number sign (#). The comments extend through the end of the line on which they appear and are ignored by Flame when the user-defined functions file is interpreted. Comments are useful for describing the purpose of a function and adding any notes you feel are pertinent. They can be introduced anywhere in the file, except for inside of function definitions that span several lines.

Sample Function Definitions

The following sample functions are found in the functions file that is installed with Flame.

- This function creates a sine curve for a given channel that oscillates between 0 and 100. The `sin100` function takes one argument, named `$arg1`, that it uses in conjunction with the predefined `sin` function. The return value for `sin100` is the sine of `$arg1` times 50, plus 50.

```
sin100($arg1) : sin($arg1)*50 + 50;
```

- This function creates a sine curve based on the specified frequency and amplitude. The `sinfreqamp` function takes three arguments, named `$pos`, `$freq` and `$amp`.

```
sinfreqamp($pos,$freq,$amp) : sin($pos*$freq)*$amp;
```

- This function provides an approximation of the speed, or more precisely, the derivative (rate of change), of a given channel. The `speed` function takes one argument, named `$channelName`.

```
speed($channelName) :eval($channelName,frame+0.1) -  
eval($channelName,frame-0.1)/0.2;
```

NOTE For information on the other example functions in the functions file, see [Slip Functions](#) on page 2056 and [Rounding Functions](#) on page 2066.

Sample Expression Setups

A few Action setups with sample expressions are provided in the directory `/usr/discreeet/<product home>/examples/action`. To load one of the setup files, open Action with front, back, and matte clips and then load one of the setup

files. You may add or change clips according to the effect that you want to produce. See [Saving, Loading, and Importing](#) on page 2126.

Animated Text

To see this example, load the example setup named *expressions_text* into Action. This example involves multiple text objects that move along a path, with each letter following slightly behind the last.

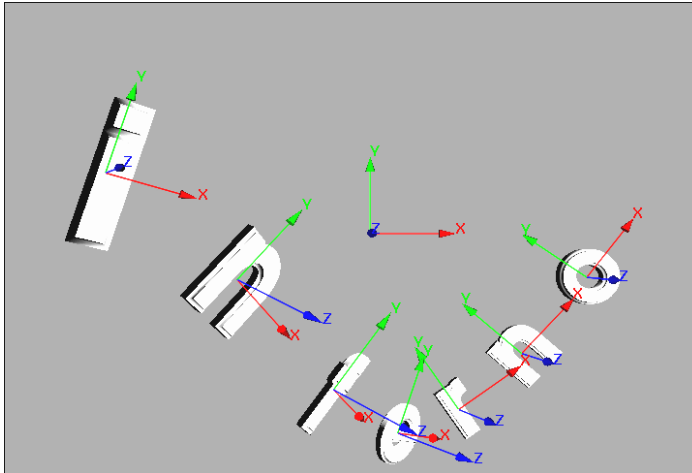

Each letter's position and rotation are created through the expressions in the following folder. The letter 'o' rotates its X-axis towards the direction of its movement. The align function is used to generate the rotation vector.

Each preceding letter sets its position and rotation an increasing number of frames behind the letter 'o'. The channel `dummy_axis.position.x` is used here to store a value determining the distance between each letter. The eval function is used to determine the values of the `o_axis.position` and `o_axis.rotation` channels at different points in time.

NOTE A series of expressions that differ only by a numeric value, such as in this example, can be entered quickly using the SelectionOrder keyword. See [Cascading Expressions](#) on page 2047.

Channel	Expression
<code>o_axis.rotation</code>	<code>align(o_axis.position)</code>

Channel	Expression
n2_axis.position	eval(o_axis.position, frame - dummy_axis.position.x * 1)
r_axis.position	eval(o_axis.position, frame - dummy_axis.position.x * 2)
e_axis.position	eval(o_axis.position, frame - dummy_axis.position.x * 3)
f_axis.position	eval(o_axis.position, frame - dummy_axis.position.x * 4)
n_axis.position	eval(o_axis.position, frame - dummy_axis.position.x * 5)
i_axis.position	eval(o_axis.position, frame - dummy_axis.position.x * 6)
n2_axis.rotation	eval(o_axis.position, frame - dummy_axis.position.x * 1)
r_axis.rotation	eval(o_axis.position, frame - dummy_axis.position.x * 2)
e_axis.rotation	eval(o_axis.position, frame - dummy_axis.position.x * 3)
f_axis.rotation	eval(o_axis.position, frame - dummy_axis.position.x * 4)
n_axis.rotation	eval(o_axis.position, frame - dummy_axis.position.x * 5)
i_axis.rotation	eval(o_axis.position, frame - dummy_axis.position.x * 6)

Spinning Dagger

To see this example, load the setup named *expressions_spinning_dagger* into Action. This example features a dagger moving in an arc. The dagger's Y-axis is aligned with the direction of its movement and the rest of the dagger spins around its axis.

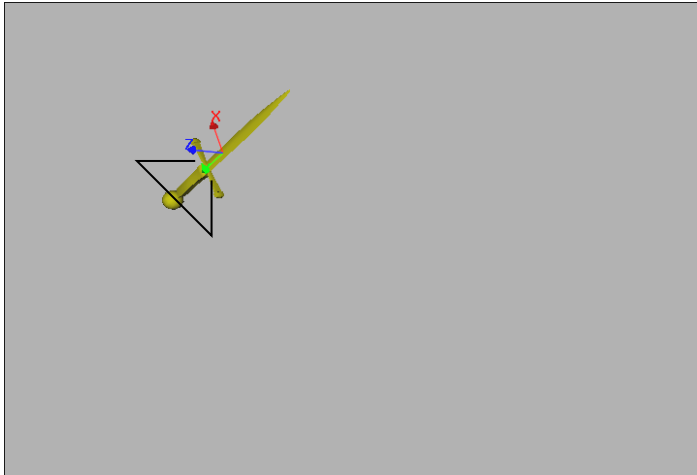

The dagger's rotation is created through the dagger's rotation of its negative Y-axis towards the direction of its movement and the rest of the dagger spins one full rotation around this same axis every 32 frames. The align function is used to generate the rotation vector.

Channel	Expression
dagger_axis.rotation	align(dagger_axis.position, (0,-1,0), frame * 2 * PI / 32)

Dagger, Apple, and Cherry

To see this example, load the setup named *expressions_dagger_apple_cherries* into Action. This animation points a dagger at either a moving apple or moving cherries, whichever is closer in position at the time.

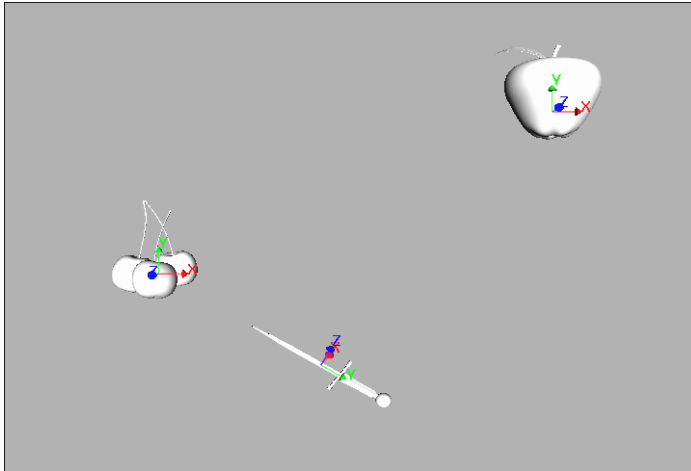

The dagger's rotation is created by the dagger's position as the dagger points its negative Y-axis in the direction of either the apple or the cherries, whichever happens to be closest. The length function is used to find the distance between the dagger and the other objects, while the if function is used to determine which is the shorter distance. The lookat function is used to generate the rotation vector.

Channel	Expression
dagger_axis.rotation	<pre>if(length(cherries_axis.position - dagger_axis.position) <length(apple_axis.position - dagger_axis.position), lookat(cherries_axis.position, dagger_axis.position, (0,-1,0), (1,0,1)), lookat(apple_axis.position, dagger_axis.position, (0,- 1,0), (1,0,1)))</pre>

Dampened Pendulum

To see this example, load the setup named *expressions_dampened_pendulum* into Action. This examples involves a pendulum (a ball attached to a rope) that swings freely back and forth under the force of gravity until it comes to a stop.

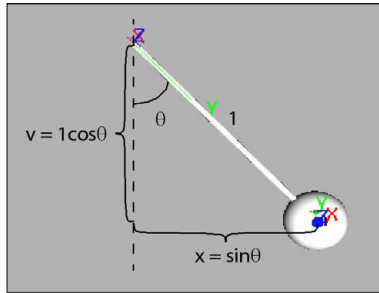

The ball oscillates in a damped harmonic motion that is created by animating the position of the ball and the rotation of the rope. The ball's x position is defined as the sine of the swing angle between the rope and centre axis, multiplied by the length of the rope. This angle is initially $\pi/2$ and decreases logarithmically. In addition, the ball oscillates with a period of 30 frames. The sin function is used to calculate the sine of the swing angle and the exp function is used to create the logarithmic dampening effect. The cos function is used to create the oscillation.

The ball's y position is defined as the negative cosine of the swing angle between the rope and centre axis, multiplied by the length of the rope. This expression is formed similarly to that of the ball_axis.position.x channel. The rope rotates such that its Y-axis is always pointing toward the centre of the ball. The lookat function is used to generate the rotation vector.

Channel	Expression
ball_axis.position.x	$\sin(\pi / 2 / \exp(\text{frame} / 100) * \cos(\text{frame} * 2 * \pi / 30)) * 200$
ball_axis.position.y	$-\cos(\pi / 2 / \exp(\text{frame} / 100) * \cos(\text{frame} * 2 * \pi / 30)) * 200$
rope_axis.rotation	lookat(ball_axis.position, rope_axis.position, (0,1,0), (0,0,1))

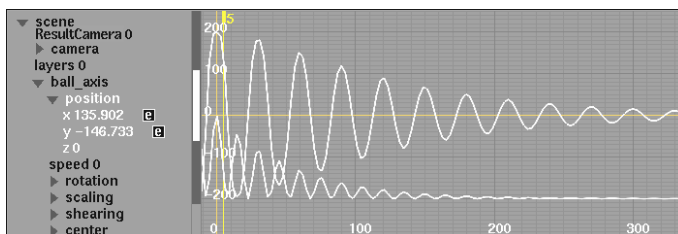

Part 12: 3D Compositing with Action

Part 12 includes these chapters:

- [Action: Basics](#) on page 2087
- [Action: Media](#) on page 2133
- [Action: DVE Layer Objects](#) on page 2155
- [Action: Axis](#) on page 2169
- [Action: Surfaces](#) on page 2177
- [Action: Sources](#) on page 2211
- [Action: Camera](#) on page 2221
- [Action: 3D Camera Tracking](#) on page 2243
- [Action: 3D Geometry](#) on page 2273
- [Action: Lights](#) on page 2307
- [Action: The Particle System](#) on page 2321



Image courtesy of Duckling A-S

Topics in this chapter:

- [About Action](#) on page 2087
- [Accessing the Action Module](#) on page 2089
- [Using Floating Point Images](#) on page 2094
- [Action Module Overview](#) on page 2094
- [Using the Schematic and Menu Tabs](#) on page 2100
- [Setup and Processing Options](#) on page 2116
- [Saving, Loading, and Importing](#) on page 2126

About Action

The Action module is a multilayer compositing tool for creating complex visual effects. Use Action to animate clips in 3D and add camera, lighting, and shadow effects.

You create effects and animations by manipulating objects in the scene. Objects you work with include surfaces, light sources, axes, particles, shadows, and the camera.

Action Concepts

The following concepts are used throughout the Action chapters to describe the workflow and user interface.

Scene The scene is Action's representation of 3D world space. It is where objects are placed and animated. World space has three directions: X (left/right), Y (up/down), and Z (in/out).

Object An object is any element in a scene. An axis, a camera, a surface, a light, or a model can also be referred to as an object.

Media Media consists of a front and matte clip only.

Surface A surface is a special type of 3D geometry onto which media is mapped.

Geometric Object (Models) A 3D geometric object can be something as simple as a cube, sphere, or cone, or as complex as a character. Although some basic geometric objects are included with Flame, most geometry is imported from a 3D application such as Maya and 3ds Max. A model is another way to refer to a geometric object.

Camera The camera represents the 'eye' you are using to see the scene. The camera is used to "record" the scene in Action. By default, the camera consists of two objects: the camera eye and the point of interest (the coordinates the camera is 'looking' at).

Axis An axis is the element of an object or media that can be manipulated to determine the object's 2D or 3D space, position, and movement.

Schematic The *schematic* is an icon representation of the scene. It shows all the objects in the scene and their relationship with each other. It is an alternative view that uses nodes to represent axes, surfaces, and other objects in the scene. Connecting arrows in the schematic show the relationships between the objects.

Schematic Nodes The schematic uses nodes to show the objects in the scene and the relationship between the nodes. Nodes are connected using arrowed and coloured lines. You use axis nodes for animating surfaces and objects, which can be connected to the camera node. You can parent one node to another, creating a *parent child hierarchy*, yielding complex animations.

Parent-Child Hierarchy This hierarchy describes the relationship between two objects where a parent object is connected to a child object. Transformations that you apply to the parent object are applied to its child object.

3D Models and Text You can import 3ds Max files, FBX® format files, Wavefront files, Inventor files, and Paint geometry into Action. Also, you can create 3D text with custom beveling.

Particles Action contains a particle system that can simulate environmental effects such as rain, snow, and many other user-defined effects.

Basic Action Workflow

The following table shows the recommended workflow when working in the Action module.

Step:	Refer to:
1. Select clips/background.	Accessing the Action Module on page 2089.
2. Create media.	Adding Media on page 2137.
3. Import objects.	Working with 3D Geometry on page 2278.
4. Add lights.	Adding a Light Source on page 2308.
5. Edit/add cameras.	Adding a Camera on page 2222.
6. Add particles.	Generating Particles on page 2324.

Accessing the Action Module

When you access the Action module, you load the front and matte clip for the first media and the back clip used for the background. You load these clips in the order front, back, then matte.

To access Action:

- 1 In the Main menu, click Effects.
- 2 In the Effects menu, click Action.



3 Select an option from the Input Mode box.

Select:	To:
Front Back Matte	Select source clips from the Desktop. The clips are selected in the order front, back, and then matte.
MultiTrack	Select a multitrack clip. The first frame of the first segment is used to fill the beginning, and the last frame of the last segment is used to fill the end. See Loading from a Multitrack Clip on page 2092.
MultiTrack Fill Gap	Select a multitrack clip. Each gap is filled with black frames. See Loading from a Multitrack Clip on page 2092.
MultiTrack SelfKey	Select a multitrack clip. The last track is loaded into the background and the other tracks are loaded as fronts. The mattes are created based on each front. Gaps are filled with the last frame from the preceding segment. See Loading from a Multitrack Clip with Selfkey or Self Gaps on page 2092.
MultiTrack Self Gap	Select a multitrack clip with gaps. Each gap is filled with the last frame from the preceding segment. Mattes are created based on each front. See Loading from a Multitrack Clip with Selfkey or Self Gaps on page 2092.
None	Enter Action with no media or back clip. From the Resolution menu that appears, choose a resolution, width, height, pixel aspect ratio, bit depth, scan mode, and frame depth. If Action already contains a setup, entering with the None option keeps the objects present in the scene and creates empty media placeholders in the Media list for each object. Press the Alt key when you click the Action button to automatically select the None option. Press Alt when you select your destination to open Action with all media and nodes deleted and all parameters (except for resolution) set to default.

Select:	To:
Clear All	To reset all parameters (except for resolution), delete all nodes and media, and prompt you to select front, back, and matte clips. Press the Ctrl+Alt key when you click the Action button to automatically select the Clear All option.

Although you can use differing resolutions per media, you cannot specify clips of different resolutions to act as the front and matte clip of media (except for 10-bit, 12-bit, and 12-bit unpacked clips, which are interchangeable). An error appears in the message bar if the specified clips are not able to be loaded to the same media.

TIP To standardize some of your clip resolutions, you can resize them before entering Action. See [Resize](#) on page 663.

- 4 Select the front, back, and matte clip or the multitrack video clip. If you selected None from the Input Mode box, proceed to the next step.

If you are selecting clips and not a multitrack clip, you can press **Ctrl** to load multiple fronts and mattes. The **Ctrl** key changes the order of clips to front and matte of media 1, front and matte of media 2, and so on. The back clip and destination are selected after the last media is filled or when the **Ctrl** key is released.

TIP Pay attention to the cursor colours to know which clips you are selecting (front = red cursor, matte = blue cursor, background = green cursor, and destination = white cursor).

- 5 Select the destination.

The Action module appears and the selected clips or tracks are loaded into the appropriate media.

The composite of the front, matte, and back clips appear in the image window and their names are listed in the Media list. The Total Frames field defaults to the length of the longest clip loaded.

Automatically Creating Image Nodes

When accessing the Action module, you have the choice of whether you want to automatically add objects to the schematic.

To access Action with auto image settings:

- 1 In Action, click Setup to display the Action Setup menu.
- 2 In the Miscellaneous section, make a selection in the Auto Image box.

Select:	To:
Auto Image	Create an image node and axis in the schematic when new media is added. This is the default mode.
Auto DVE	Create a DVE Layer Object node in the schematic when new media is added.
Auto Image Off	Not add any nodes to the schematic when new media is added.

Loading from a Multitrack Clip

When you load from a multitrack clip, the tracks from the selected multitrack clip are loaded from the bottom track to the top track. The last track is loaded as the background and subsequent tracks are loaded as matte and front pairs. This means that the last track is loaded as the common back clip, the second to last track is loaded as the matte clip of media 1, the third to last track is loaded as the front clip of media 1, the fourth to last track is the matte clip of media 2, and so on.

NOTE If you select an even number of tracks when loading from a multitrack clip, the second to last track selected is loaded as the front clip for its media, and the matte for this media is set to an internal white frame (of the same resolution as the front clip).

Gaps that are located at the start and end of a track are treated in two ways depending on which multitrack option you choose. If you select MultiTrack, each gap is filled with its preceding non-gap frame. If you select MultiTrack with Gap, each gap is filled with black frames.

Loading from a Multitrack Clip with Selfkey or Self Gaps

When you load from a multitrack clip with Selfkey or Self Gaps, the tracks from the selected multitrack clip are loaded from the bottom track to the top track. The last track is the background or back clip and subsequent tracks are loaded as front clips for each media. The matte of each media is generated

from the front clip. This means that the last track is loaded as the common back clip, the second to last track is loaded as the front clip of media 1, the third to last track is loaded as the front clip of media 2, and so on.

Gaps located at the start and end of a track are treated in two ways depending on which multitrack option you select. If you select MultiTrack, each gap is filled with its preceding non-gap frame. If you select MultiTrack with Gap, each gap is filled with black frames.

Accessing Action through Batch

While working in the Batch module, you can access the full Action module by clicking any Action node in your process tree. See [Assembling a Process Tree](#) on page 1283.

Resetting Values

When beginning a new project, you can reset just the parameters, or reset and delete nodes and remove media. Resetting can also be used to remove all effects and edits created during an Action session. The Reset All button is located in the Action Setup menu.

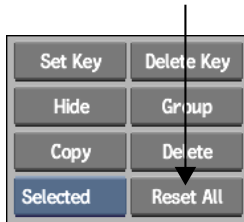

Click:	To:
Reset All	Reset all parameters but not delete nodes or media once confirmed.
Alt+Reset All	Same as Reset All, but confirm prompt is bypassed.
Ctrl+Reset All	Reset all parameters and delete all nodes and media once confirmed.

Using Floating Point Images

You can use 16-bit floating point OpenEXR clips in Action. You can use clips of different resolutions on separate media, but you cannot specify clips of different resolutions to act as the front and matte clip of a specific media. Here are some things to keep in mind when working with 16-bit floating point clips:

- You are not able to enter the Colour Corrector, Keyer, or Stabilizer from Action with a 16-bit floating point clip. An error appears in the Action message bar, and the module does not open.
- All other Media List effects, such as blurring, cropping, and slipping are supported for 16-bit floating point clips, as are all Action objects.
- Action operations and settings that are supported with 16-bit floating point clips include 3d tracking, textures, displacement mapping, motion blur, blending modes, anti-aliasing, and depth of field.
- You can enable or disable colour clamping when working with 16-bit floating point clips in Action. When colour clamping is disabled, a light's intensity can be set to brighter than 100% or darker than 0%, for example. The Colour Clamping button is located in the Setup menu's Rendering section.
- You can set the output resolution for your Action composite to 16-bit fp in the Frame Depth box located in the Setup menu's Resolution section.
- You are not able to burn 16-bit floating point clips. An error appears in the Action message bar.

Action Module Overview

The Action module is divided into a number of menus and sections designed to help you quickly create your composites.

Changing Views

You can change the orientation to view a scene from many angles. This can help you set up motion paths, light sources, and camera angles more easily.



(a) View box (b) Process View box

Select in the View box: To view:

Reference	The current reference frame in the reference buffer.
Source	The interactive result of a source node.
Out Matte	The Matte that will be outputted.
Media List	The Media list.
Priority	The Priority Editor.
Media Back	The back media for the selected media in the schematic or Media list.
Media Matte	The matte media for the selected media in the schematic or Media list.
Media Front	The front media for the selected media in the schematic or Media list.
Info	The animation channels (set to the Channel Information view mode).
Tracks	The animation channels (set to Track view mode).
Channels	The Channel Editor.
Schematic	The Action schematic.

Select in the View box:	To view:
Top	The scene from above, along the Y-axis.
Side	The scene from the side, along the X-axis.
Front	The scene from the front, along the Z-axis.
Camera	The scene from the defined camera's view.
Result	The result of the composite created in Action.
Context (Batch Only)	The context that is set in Batch when accessing Action through Batch. Action uses Context1 as it is set in Batch. For example, if the Batch context is set on the result of an Optics node for which the current Action node is an input, changes you make in Action appear in context of the Optics node. See Viewing Nodes in Context on page 1315.

A subset of the media views is available from the Process View box. Select an option to specify the view displayed when you process a scene in Action. For example, the View box may be set to Schematic, but while you process intermediate results in Action, you would like to view the scene from the camera's view. In this case, you can select Camera from the Process View box, and then click Process.

Accessing Action Menus

Use the Action menu buttons to switch between the various Action menus. The Action menus are also context sensitive depending on what is selected in the image window. Details of the Action menus are documented in their corresponding chapters.

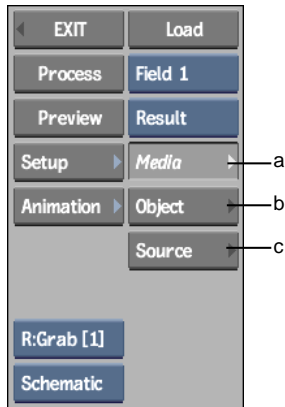

(a) Media menu button (b) Object menu button (c) Source menu button

Using the Node Bin

The node bin contains all of the objects that you can add to your scene. The node bin also contains an image node that displays a proxy of the currently selected media.

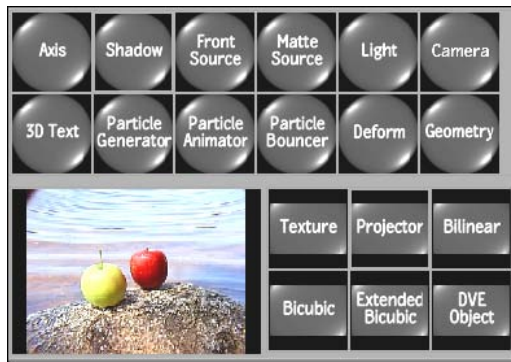

To add a node:

- 1 Do one of the following:
 - Drag the selected node from the node bin and place it in the schematic. If the node is an image type node, an axis and an image are created and linked together.

- Drag the node from the node bin and place it where you want it in Result view. For example, as you drag a Light node into Result view, it becomes active, so you can see its effect on the scene before placing it exactly where you want.
- Double-click a node. The node appears next to the last added object. You do not need to be in Schematic view to add a node in this manner. You can choose from the following node types.

Select:	To add:
Axis	An axis. See Accessing the Axis Menu on page 2171.
Shadow	A shadow to the selected surface. See Adding Shadows on page 2202.
Front Source	A front source node. See Action: Sources on page 2211.
Matte Source	A matte source node. See Action: Sources on page 2211.
Light	A light source. See Adding a Light Source on page 2308.
Camera	Another camera to the scene. See Adding a Camera on page 2222.
3D Text	3D text. See Creating 3D Text on page 2300.
Particle Generator	A particle generator. See Generating Particles on page 2324.
Particle Animator	A particle manipulator (referred to as a particle animator in the schematic). See Manipulating Particles on page 2343.
Particle Bouncer	A particle bouncer. See Bouncing Particles on page 2362.
Deform	A deformation mesh to a selected image or 3D model. See Deforming Models and Surfaces on page 2296.
Import	A 3D model. See Importing 3D Models on page 2274.
Texture	A texture to the selected geometry or particle generator. See Adding Textures on page 2284.
Projector	A projected clip to the scene. See Projecting Textures on page 2289.

Select:	To add:
Image (proxy)	An image (with axis) to the scene. You can change the surface type of the image. See Changing the Shape of a Surface on page 2183.
DVE Object	A DVE Layer Object to the scene to emulate the axis and surface structure of DVE clip layers. See Adding a DVE Layer Object on page 2156.
Bilinear	A surface with four corners joined using linear interpolation. See Adding Surfaces on page 2178.
Bicubic	A surface with four corners joined using bicubic Bezier interpolation. See Adding Surfaces on page 2178.
Extended Bicubic	A surface with four corners joined using bicubic Bezier interpolation. You can subdivide Extended Bicubic surfaces to obtain additional tangents. See Warping an Extended Bicubic Surface on page 2190.

TIP From the node bin, swipe down to display the small schematic. You can use the small schematic as a viewing aid instead of using the larger schematic in the image window. The small schematic displays the same view as the schematic. When you move, pan, and frame nodes in the small schematic, the larger schematic is updated as well.

Animating with the Channel Editor

Use the Channel Editor to animate the media, axis, surface, light, and camera properties of every object in the scene.

To open the Channel Editor and display the Action channels:

- 1 In Action, click Animation.
- 2 In the Animation menu, select Channel from the View box.
The top-level folder in the hierarchy is the Scene, which provides the overall view of the animation. The Scene folder contains folders of objects in the Action scene. Initially these are the Camera, Media, Axis, and Image folders.

If you add an object to the scene, the Channel Editor adds a folder to the channel hierarchy for the new object. For example, if you add a light, a Light folder is added in the channel hierarchy. See [Viewing Channels in a Table](#) on page 1985.

Some of the Action folders in the Channel Editor are described as follows. For complete information about using the Channel Editor and animating objects in the scene, see [Animation](#) on page 1963.

Camera Animates the camera position and point of interest. It also contains channels for animating camera roll, field of view, and the near and far clipping planes.

When Free Camera is selected, the point of interest channels are replaced by rotation channels in the Channel Editor.

Media Animates media properties such as blur, crop, shadow softness. A Media folder is listed for each media in the scene.

DVE Layer Objects Animates the axes and surfaces of DVE Layer Objects (displayed as a folder DVE_Lx in the Channel Editor, where x is the layer number).

Axis Animates axis properties such as position, rotation, scaling, and shearing.

Image, Bilinear, Bicubic, or Extended bicubic Animates surface properties such as material, offset, and displacement. The Material folder contains a shininess channel and folders for the specular highlight, diffuse, and ambient lighting.

Shadow Animates the shadow colour and shadow transparency.

Light Animates light properties such as intensity, falloff, spread, position, rotation, and colour.

TIP Selecting nodes in the schematic will automatically select the associated channels in the Channel Editor.

Using the Schematic and Menu Tabs

In Schematic view, a node exists for each object in the scene. For example, the camera, axes, shadows, and lights are represented by circles. Surfaces and textures are represented by rectangles. Each node displays the name of the object it represents.

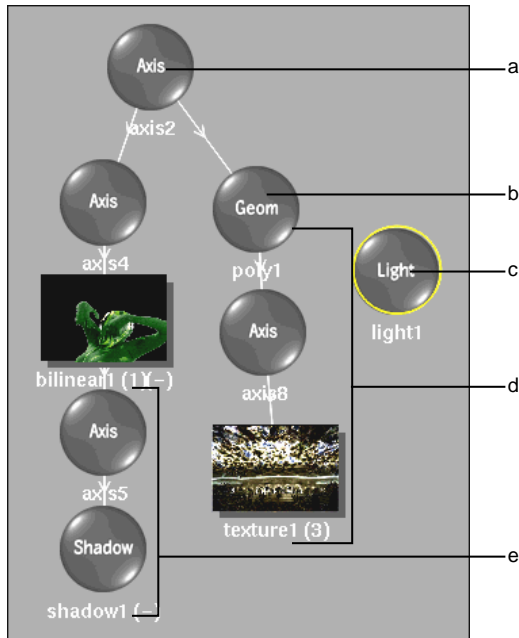

(a) Axis object is the parent of axis 4 and poly1 (b) 3D model (c) Light source (d) Texture applied to the 3D model (e) Drop shadow of bilinear1

Here are some hints when working in the schematic with some of the various node types.

Surface Nodes (Bilinear, Bicubic, and Extended Bicubic) When you add one of these surface nodes to the schematic, the node name is shown with two numbers in parentheses. These numbers indicate the media applied to the surface and the media used as a displacement source. For example, a bicubic object labeled (2)(1) shows that the bicubic uses the clips from Media 2 and is displaced using the clips from Media 1.

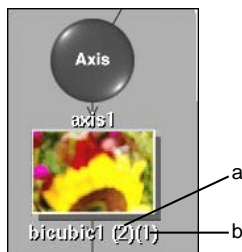

(a) Media 2 is used by the bicubic surface. (b) Media 1 is used for displacement.

For more information on the relationship between media and surfaces, see [Adding Surfaces](#) on page 2178. For more information on displacement, see [Adding a Displacement Map](#) on page 2198.

DVE Layer Object Node A DVE Layer Object node is a special node designed to simplify working in the Action schematic. A DVE Layer Object node is a grouped node of all axes and surfaces that DVE users are accustomed to using. See [Adding a DVE Layer Object](#) on page 2156.

Camera Node The camera node appears in Schematic view by default and you can link it to any image. Use the camera node to rotate the camera about its own axis, and parent other nodes including shadow, texture, and geometry nodes.

Shadow and Texture Nodes Shadow and texture nodes each have a single number in parentheses that indicates the media used for the shadow or texture. For example, a shadow labeled (2) shows that the shadow uses the matte from Media 2.

Source Nodes Source nodes are used as part of an advanced schematic structure that separates the media's matte and front so that each clip can be animated individually. You can also use sources to create complex compositing effects such as nesting. See [Action: Sources](#) on page 2211.

TIP To view the schematic, select Schematic in the View box, or press ' (on the Tilde key). Pressing the ' key a second time returns to the previous view.

Selecting Objects and Populating Menu Tabs

Before you can edit or animate an object, you must select it. To select an object in the schematic, click the node representing the object. You can also use the Prev and Next buttons to select the previous or next object.

Depending on what type of object is selected, the tabs in the Object menu are populated based on different rules, as illustrated in the following examples.

Axis selected

The Axis menu of the selected axis appears on the left side of the Object menu, and a limited number of the children objects' menus appear on the right side of the Object menu. The children objects are identified by scanning the hierarchy of the schematic from top-to-bottom (starting at the selected axis). The hierarchical scanning stops for any given branch when a non-axis object is encountered.

The order of tabs is determined on a per branch basis; that is, all of the tabs of one branch are listed before moving to another branch, starting with the highest levels in the parenting hierarchy (lowest index levels).

For example, in the following schematic, Axis 1 is selected.

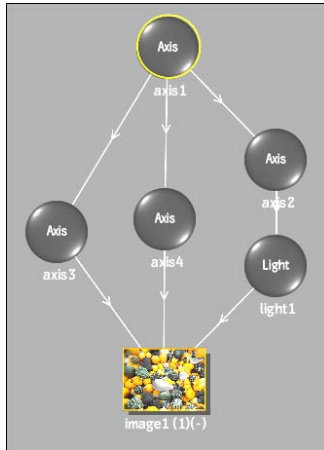

The tabs in the Object menu appear as follows. The image1 tab appears in light blue to signify that multiple objects are connected down to it. Use the tabs to switch between menus within the Object menu. The Camera tab appears in orange as the first tab on the right side of the Object menu, and is exempt from the tab population rules.

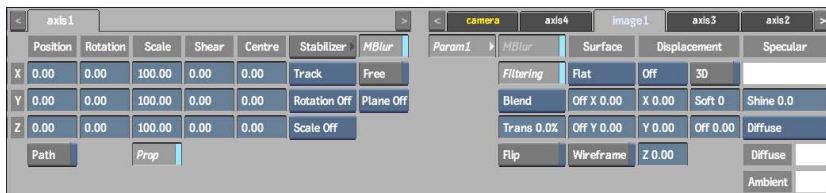

NOTE If there are more than five tabs on either side of the Object menu, use the arrows beside the tab names to navigate to the desired tab.

Other object selected (no “axis attributes”)

These objects include generators, bouncers, deformations, surfaces, textures, shadows, geometries, and 3D text. When one of these objects is selected in the schematic, an ascending (bottom-to-top) scanning of branches is performed. The hierarchical scanning stops for any given branch when an axis or object with axis attributes is encountered.

The menu of the selected object appears on the right side of the Object menu, and a limited number of the parent objects' menus appear on the left side of the Object menu.

For example, in the following schematic, Image 1 is selected.

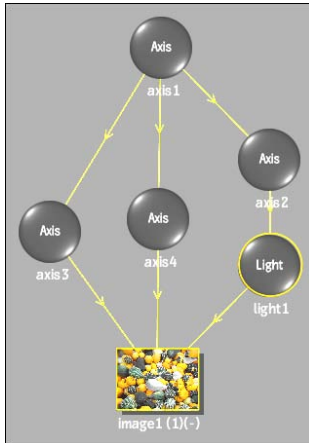

The tabs in the Object menu appear as follows. The image1 tab appears in light blue to signify that multiple objects are connected down to it. Use the tabs to switch between menus within the Object menu. The Camera tab appears in orange as the first tab on the right side of the Object menu, and is exempt from the tab population rules.

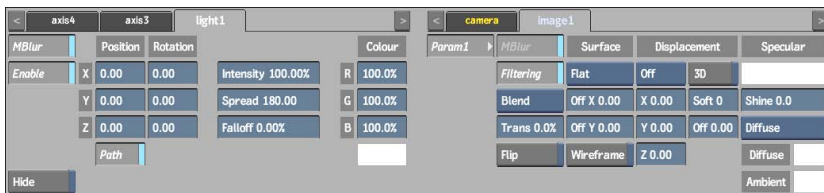

Object with “axis attributes” selected

These types of objects include lights, animators, projectors, and cameras. These objects trigger a different scanning behaviour depending on their position within the schematic hierarchy. If the selected object is the first of its branch (top of the hierarchy), it inherits the tab population rules of an axis, that is, descending branch scanning. If the selected object is not the top object of its branch, it inherits the tab population rules of other objects, that is, ascending branch scanning.

For example, in the following schematic, light 1 is selected.

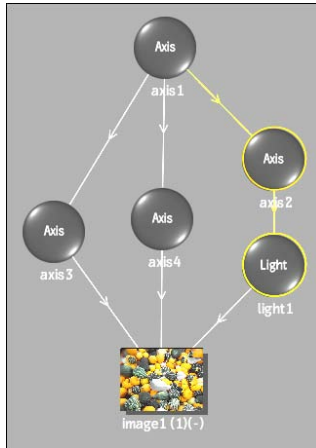

Since Light 1 is not the top object in its branch, the tabs in the Object menu appear as follows.



In the following schematic, light 1 is moved to the top of the branch.

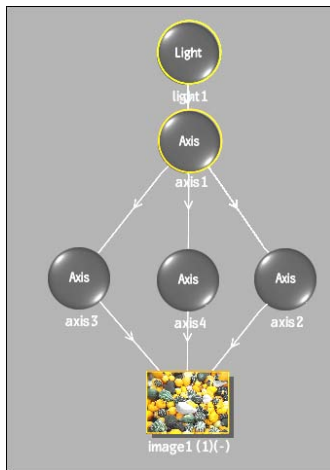

The tabs in the Object menu appear as follows. The image1 tab appears in light blue to signify that multiple objects are connected down to it. Use the tabs to switch between menus within the Object menu.



NOTE The Camera tab appears in orange as the first tab on the right side of the Object menu, and is exempt from the tab population rules. If a camera node is selected in the schematic, the special Camera tab does not appear, and the normal tab population rules apply.

Selecting Multiple Objects in the Schematic

Press **Ctrl** and drag in the schematic to select multiple nodes. You can then relatively change some of the settings in the Object menu for all objects of the same type.

Objects that support multiple selection and changing of field settings are axes, images, shadows, and lights. For example, in the following schematic, you can select all of the nodes.

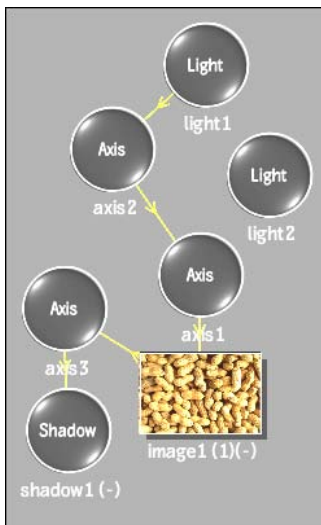

The tabs in the Object menu reflect the multiple selections.



In the Object menu, you can relatively change any of the available fields. For example, if the X Position for Axis1 and Axis2 was originally 100, and for Axis3 was 200, and you drag the X Position slider under the Mult-axes tab to 50, Axis1 and Axis2 are now set to 150 and Axis3 is set to 250.

NOTE Because the field values for individual objects can be different, the values in the multiple selected fields display as default values in the Object menu. When you select an individual object and view its Object menu, you can see the true field values.

Naming Objects

Each node that you add to the scene is automatically assigned a default name. The default name identifies the object and the order in which it was added. For example, image surfaces are named image1, image2, image3, and so on. Similarly, bilinear surfaces are named bilinear1, bilinear2, bilinear3, and so on.

Newly added nodes take the lowest available number. For example, in a scene with image1 and image2, if you delete image1, then add a new image, it becomes image1.

An object's name appears beneath its node in the schematic, on the Object menu tab, and as a folder in the Channel Editor.

You can assign more meaningful names to nodes.

NOTE To avoid conflicts in the Expressions editor and the schematic, you cannot duplicate names. When you duplicate an existing object name, newly created objects have a "0" appended to their name. For example, if objects 1, 2, 3 already exist, three newly created objects would be named 01, 02, and 03.

To change the name of an object:

- 1 Select the object in a view that supports selections, such as result or schematic view.

The current name for the object appears in the Name field.

- 2 Click the Name field and type the new name.



- 3 Press **Enter**.

The schematic, Object menu tab, and Channel Editor update to show the new name.

Moving Objects

Use Move mode to move objects in the schematic. Moving the objects in Schematic view has no effect on the relationships between objects, nor does it affect the position of the object in the scene. If Auto Parent is enabled in the Setup menu, Move mode acts as both Move and Parent.

To move an object in the schematic:

- 1 From the Edit Mode box, select Move.



- 2 Click the object you want to move and drag it to a new position.

TIP To move an object between two linked nodes, hold **Shift** and drag the node on top of the link. To remove an object between two linked nodes, hold **Alt+Ctrl** and drag the object away from the link.

Deleting Objects

You can use various methods to remove objects from the schematic.

To delete an object using the Edit Mode box:

- 1 From the Edit Mode box, select Delete.
- 2 Click the object that you want to delete.
The object is removed from the scene.

TIP Press **Shift** before clicking the object to recreate the links to any parents or children linked to the deleted object.

To delete objects using the Delete button:

- 1 From the Selection box, select an option.

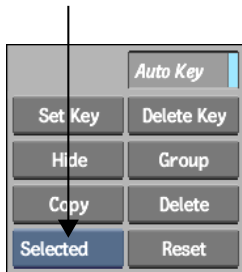

Select:	To:
---------	-----

Selected	Delete the currently selected object. For example, this option deletes a surface without deleting its parent axis, or an axis without deleting its surface.
----------	-------------------------------------------------------------------------------------------------------------------------------------------------------------

Branch	Delete the selected object and all its children. To avoid deleting nodes by mistake, use the Schematic view to determine which nodes you are deleting.
--------	--------------------------------------------------------------------------------------------------------------------------------------------------------

All	Delete all objects in the scene, except the default camera.
-----	-------------------------------------------------------------

- 2 Click Delete.

To delete objects by dragging items out of the schematic:

- 1 Drag an object to the bottom of the screen. The cursor changes to a green recycling icon. The object is selected for deletion and you are asked to confirm. Click Confirm or press **Enter**.

TIP Press **Shift** before dragging the object to recreate the links to any parents or children linked to the deleted node.

Creating Branches

In Action, you can create complex animations where movements applied to one node are passed down to all connecting nodes. The relationship between objects is referred to as a *parent-to-child* relationship where the *parent* node passes down its animations to its child *object*. The structure of one parent and one or more child nodes is referred to as a *branch*.

Use the Parent and Cut options in the Edit Mode box to change the parent-to-child relationship between nodes in the schematic. Parent mode makes an object the parent of another object. Cut mode removes the parent-to-child relationship between objects. Alternatively, when Auto Parent is enabled in the Action Setup menu, you can automatically parent objects in the schematic.

When you add certain nodes to the scene, a parent-to-child relationship is created automatically. For example, when you add a surface to the scene, it is automatically parented by an axis.

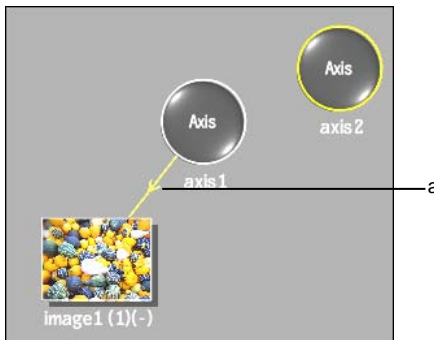

(a) An arrowed line indicates that axis1 is the parent of image1.

You can add an axis to the scene by itself, then make it the parent of another node. Use this method of parenting additional axes to create complex animations.

For example, create a cube of surfaces by parenting three additional axes to the same surface. Each axis that is parented to a surface places an additional surface in the scene. By changing the position and rotation of each axis, you

can create a cube. If you parent the axes with another axis, you can control the position, rotation, scale, and shear of the cube.

To create a branch:

- 1 Add an axis (axis2) to the scene.
- 2 From the View box, select Schematic. The Schematic view should be similar to the *Before* figure.
- 3 Do one of the following:
 - In the Edit Mode box, select Parent and drag the cursor from the edge of the parent node to the node that will be its child.
 - Press **Shift** and drag a parent node over another node that will be its child. With this method, the Edit Mode box does not have to be set to Parent mode, and can remain in Move mode, for example.
 - In the Action Setup menu, enable Auto Parent in the Schematic section, and then in the schematic, drag the cursor from the edge of the parent node to the node that will be its child. With this method, the Edit Mode box does not have to be set to Parent mode, and can remain in Move mode, for example.

TIP To quickly cut a parent-to-child relationship, drag the cursor across the line that joins the two nodes.

Axis2 becomes the parent of axis1, as shown in the *After* figure.

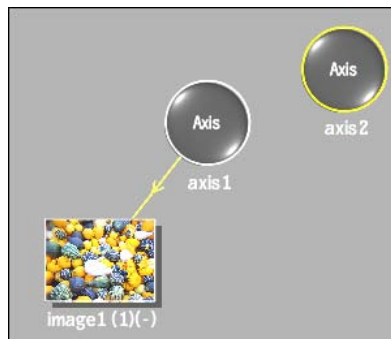

Before: The schematic shows axis1 as the parent of image1

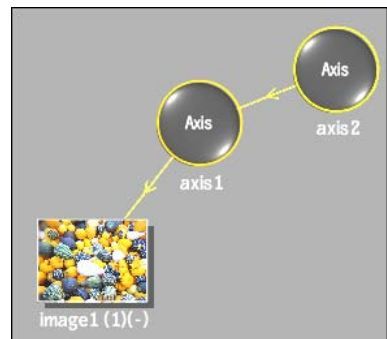

After: Axis2 is made the parent of Axis1 using Parent mode

Any transformations applied to axis2 are applied to axis1 and its surface (image1). If axis1 has any transformations, they are added to the transformations from axis2. For example, if axis2 is set to 500, 100, 0 and axis1 is set to -50, 20, -30, the positions are accumulated and applied to the surface. In this case, Image1 is positioned at 450, 120, -30.

You can override the transformations passed from a parent to a child by enabling the Free button in the Axis menu.

Duplicating Objects

You can duplicate objects of the same type so that any settings applied to the first object are also applied to the duplicated object or objects.

The originating object can link to multiple duplicate objects, but only one object can be the originating link.

To duplicate objects:

- 1 From the Edit Mode box, select Duplicate (or press **W**).
- 2 In the schematic, drag between two similar object types.
A green arrowed dotted line indicates that the objects are linked as duplicates.

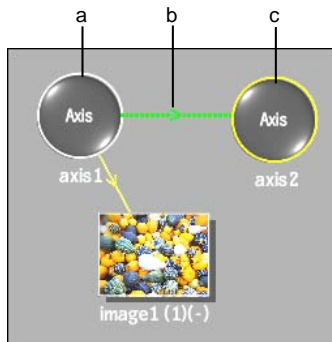

(a) Originating object (b) Duplicate link (c) Linked object

TIP While in Move mode, you can also create a duplicate link by pressing **Shift+W**, and dragging the originating node over the to-be-linked node. Press **Alt+Shift+W** while dragging to invert the link orientation.

All of the settings applied to the original object are automatically applied to the linked object. Once objects are linked as duplicates, any settings applied to either object are applied to both.

NOTE To remove the link between duplicate nodes, drag the cursor across the green line that joins the two nodes, or press **Ctrl+Alt+W** while moving a linked node. Each node keeps the settings that were applied while they were linked.

Hiding Objects

Use the Hide button to hide or unhide selected objects, branches, or all. For example, when you are working on a specific surface, you may want to temporarily remove other nodes from the scene without deleting them.

Hidden objects are marked “(hidden)” in Schematic view and do not appear in the scene.

To hide an object:

- 1 In the schematic, select the object you want to hide.
- 2 From the Selection box, select Selected.

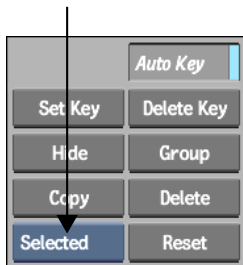

- 3 Click Hide.

To hide a branch:

- 1 In the schematic, select the parent of the branch you want to hide.
- 2 From the Selection box, select Branch.
- 3 Click Hide.

To unhide an object or branch:

- 1 Select the hidden object or branch.
- 2 From the Selection box, select Selected or Branch.
Use Selected if you are un hiding an object and Branch if you are un hiding a branch.
- 3 Click Hide.

To hide all:

- 1 Select the hidden object or branch.
- 2 From the Selection box, select All.
- 3 Click Hide.

Copying Objects

Use the Copy button to copy an object, a branch (object and its children), or all.

To copy a single object or branch:

- 1 In the schematic, select the object you want to copy.
- 2 From the Selection box, select an option.

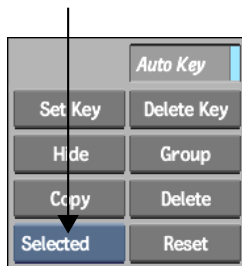

Select: To copy:

Selected The currently selected object. For example, this option copies a surface without copying its parent axis, or an axis without copying its surface.

Branch The selected object and all its children. To avoid copying nodes by mistake, use the Schematic view to determine which nodes you are copying.

Select:	To copy:
All	All nodes in the scene.

- 3 Click Copy.

Collapsing Branches

You can collapse branches in the schematic into a group to reduce clutter in the schematic.

You can also parent nodes to a group.

To collapse a branch:

- 1 Select an object with children in the schematic view.
- 2 Click Group to collapse the selected object and all its children into a group.

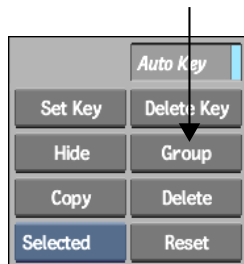

A blue group node appears in the schematic to represent the entire group.

NOTE Collapsed groups cannot act as parents.

To uncollapse a node:

- 1 Click Group again to uncollapse the group.

NOTE Groups created in the Schematic view are not related to groups created in the Priority Editor.

Removing Branches

You can use Cut or Parent mode to undo the relationship between objects or you can simply drag the cursor across the line that joins the nodes.

To cut a parent-to-child relationship:

- 1 From the Edit Mode box, select Parent.
- 2 From the View box, select Schematic.
- 3 Drag the cursor across the line that joins the two objects.

The connecting line is deleted and the relationship between the two objects no longer exists.

Setup and Processing Options

Use the Action Setup menu to customize your Action display and to access tools and guides.

When exiting Action to the Desktop, a backup of your setup is automatically saved. This backup file is only created from the Action module and called from the Desktop when reentering the Action module.

To access the Action Setup menu:

- 1 In Action, click Setup.

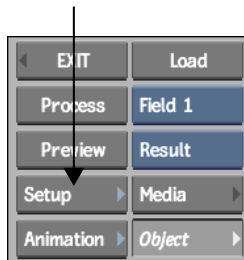

Resolution Settings

You can set the rendering resolution of clips that are output in Action. For example, if you are working in an NTSC 8-bit project, the default output is

NTSC 8 bits. However, if you want to change the output resolution to HD (1920x1080), use the Resolution menu to change the values so the final outcome will be 1920x1080.

You can choose between progressive or interlaced when rendering at video resolution. Action media automatically adjust the rendering mode of each clip. This inherent awareness also makes it possible for Action to properly mix field-based HD / PAL with NTSC and not have dominance problems.



Output Resolution box Defines the resolution of a processed clip. Select whether you wish to output Full resolution or Proxy resolution (defined in the Proxy Resolution field).

Alternatively you can set a custom resolution by entering values in the Width and Height fields.

Aspect Ratio Presets box Defines the render/output aspect ratio of clips processed in Action.

Aspect Ratio field Defines a custom render/output aspect ratio of clips processed in Action.

Frame Depth box Defines the render/output frame depth of clips processed in Action.

Scan Mode box Defines the scan mode of clips processed in Action.

Apply and Scale box Applies or applies and scales the defined resolution, aspect ratio, and frame depth. All subsequent processes will use the new render settings.

Select:	To:
Apply	Specify the output resolution.
Apply + Scale	Specify the output resolution and scale a scene to the defined resolution. Use this option if you are working with a low resolution of an Action setup from a previous version of Flame. The scaling is applied

Select:

To:

to geometries, axes, lights, and cameras as well as their coordinates.
Their positions are scaled accordingly.
Flame automatically scales textures and images.

NOTE If you do not change the Resolution settings, rendered results and camera settings default to the values set for the current project (set when you created a new project).

Rendering Settings

Use the Rendering settings to improve the final output quality of your image.



Anti-aliasing Sample box The jagged lines that often occur along the edges of diagonal or curved lines when processing high-frequency images such as text are the result of aliasing. You can increase or decrease the anti-aliasing sampling level (up to 64 samples). Higher values yield smoother results at the expense of processing time.

Anti-aliasing Softness field Defines the softness of the anti-aliasing sample.

Z-Buffer box Uses the distance from the camera eye to determine the order in which objects are rendered. See [Analyse, Z-Sort, and the Z-Buffer](#) on page 2208.

Resolution field Specifies the geometry resolution (number of polygons) of surfaces.

The lower the value, the better the resolution and the greater the processing time required to interact with the image. A value of 1 creates one polygon per pixel on a surface, affording accurate displacement and lighting.

Use this field when exploding a surface with a particle generator and when using hardware texture mapping. See [Exploding Objects and Surfaces](#) on page 2340.

Shading button Lights up the scene using added light sources. When Shading is disabled, no lighting effects appear in the scene; surface and 3D models appear flat.

Enable Shading for:

- Light sources
- Ambient or diffuse lighting for surfaces
- Specular highlights for surfaces and 3D models

Texture button Enables hardware texture mapping, which you can use with any surface resolution. If the image is larger than the texture, Action creates tiles and does not use a low-resolution image.

When Texture is disabled, the media mapping to the surface is done at the specified resolution.

Wireframe button Displays each surface and 3D model as a wireframe. This is useful if interaction with Action becomes slow because of many surfaces and 3D models. Convert objects to wireframe when you want to speed up processing or rendering times. Because lighting and textures are not computed in wireframe mode, interaction time and rendering times are reduced.

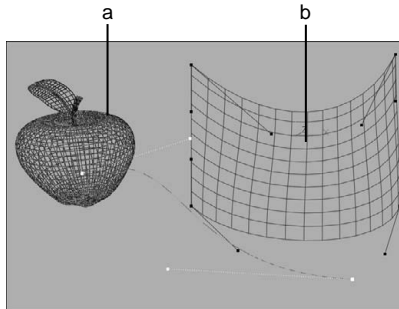

(a) 3D model in wireframe mode (b) Bicubic surface in wireframe mode

Linetest button Processes or previews a clip using the resolution value specified in the Resolution field. This is useful if you want to generate an intermediate clip to check your animation.

Linetest is ignored when Texture is enabled.

Colour Clamping button Enable to clamp colour and luminance on 16-bit floating point clips. Disable colour clamping to allow pixel floating point values to be less than 0 or more than 100.

Accumulation Settings

You can enable motion blur and specify motion blur settings. See [Applying Motion Blur](#) on page 2237 for specific examples of creating motion blurs.

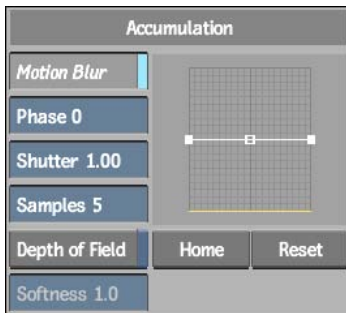

Motion Blur button Enables motion blur.

Phase field Specifies whether the motion blur is based on the movement before or after the current frame. A value of -100 places the motion blur before while a value of 100 places the motion blur after. A value of 0 is centred, which evenly distributes the motion blur. The default value is 0.

Shutter field Controls the duration of motion blur at each frame, which affects the size of the motion blur. Increasing Shutter value does not increase the processing time.

Samples field Determines the quality of the motion blur and the depth of field produced by the number of samples taken at each frame. Increasing the Samples value causes the processing time to increase linearly and affects the quality of the depth of field.

The number of motion blur samples is multiplied by the number of anti-aliasing samples. To reduce the total number of passes made for each frame, reduce the level of anti-aliasing when motion blur is enabled.

Depth of Field button Enables the camera's depth of field.

Depth of Field Softness field Defines the softness of the depth of field. A low value yields a sharp falloff between focused and unfocused regions.

Motion Blur curve Controls the sample weight over the scope of the motion blur.

Home button Resets the position of the motion blur curve after panning.

Reset button Resets the motion blur curve.

Miscellaneous Settings

Use these settings to define various Action properties.



Motion Update button Updates properties such as position, rotation, and colour in the scene. This button is enabled by default.

When disabled, animated objects do not move, but keep the position of their current value. Disable Motion Update when you want to copy keyframe values from one frame to another.

Play Lock button Updates the animation settings according to the frame or timebar position as you move through the clip while keeping it locked at the current frame.

When Play Lock is disabled and you use > or < to play the resulting clip, each frame is loaded and displayed in sequence in the image window.

Use Proxies button Enables proxies for media in Action. Using proxies increases interaction speed, especially when working with high-resolution images.

TIP You can also toggle proxies by pressing **Ctrl+P**.

Proxy Media option box Specifies for which media proxies are used. Press **Shift+P** to toggle the proxy media behaviour.

Select:	To:
All Media	Work in proxy resolution for all media loaded into Action.
Full Res Media	Use the full resolution clips for the current media. This option is useful when accessing modules such as the Keyer or Colour Corrector from Action. When you go into a module with media selected, the

Select:	To:
	full resolution clips for the selected media are loaded into the module.

NOTE When you enter the Colour Corrector or Keyer from media in proxy mode for a 12-bit clip, a message warns you that there will be a precision loss if you have already worked on a media using the full-resolution 12-bit clip. You can confirm, or switch to Full Res Media before reentering the module.

When you are ready to process your final output, disable Use Proxies. If you process with Use Proxies enabled, the processed clip will be rendered using the proxies.

Undo Levels field Sets the number of operations you can undo. The Undo and Redo buttons each have a list allowing you to select the most recent operations to undo or redo. You cannot undo a Delete operation for media.

Setting the undo levels to a large number uses more memory. The default is 10.

Edit Front Only button Enables the display of the front media in the Media menu. When disabled, the front and matte media are displayed.

MK As Default button Enable to set the Modular Keyer as the default keyer when accessing the Keyer from the Media menu.

Auto Image option box Specifies whether nodes are automatically created in the scene when a new media is added.

Select:	To add to the scene:
Auto Image	An image node and axis.
Auto DVE	A DVE Layer Object
Auto Image Off	No nodes are automatically added to the scene.

Backup button and field Back up your Action setup automatically. A backup copy of current Action settings is saved in the `_action.bak` file in the Action directory.

You can set the number of minutes between backups using the Backup field next to the Backup button.

NOTE The Action backup button is not available when accessing Action through Batch. If a backup is needed, you can use the Batch backup.

Display Settings

Use these setting to customize your Action display.

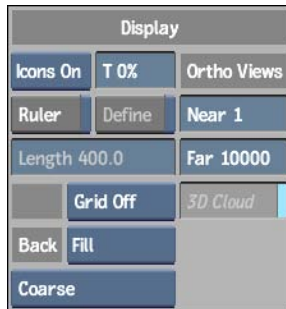

Icons box Indicates object (axes, borders, control points) display options. The selected option displays icons only for the object currently selected in the scene.

TIP You can also display the axis icons in 2D to increase your interaction speed. You can set the setenv `DL_ACTION_2D_AXES 1` in the `.cshrc` file.

Icon Transparency field Sets the transparency for icons that represent axes, lights, motion paths, and 3D geometry in the scene.

Ruler button Enables the ruler in the scene area.

Use the arrows at each extremity of the ruler to place the beginning and end of the ruler anywhere in your scene view.



TIP Use the **Shift** key to snap the ruler into place either horizontally or vertically.

(Ruler) Define button Enable to define real unit measurements, such as feet, metres, or inches, instead of pixels. All camera distance or axes measurements thereafter use the defined scale.

(Ruler) Length field Enter a value in the Length field. The number can represent any measuring unit (feet, metres).

When you enter a length, click Define again to apply the new scale to the ruler and all pertinent fields, such as position, rotation, and scale.

TIP Hold the **Ctrl** key and click Define to reset the ruler's scale.

Grid box Display a grid in the scene to position objects more accurately.

Select:	To:
Grid Off	Disable the grid.
Grid XY	Use a grid constructed on the X and Y planes.
Grid XZ	Use a grid constructed on the X and Z planes. The XZ grid is visible only when the camera is moved from its default position.
Grid YZ	Use a grid constructed on the Y and Z planes. The YZ grid is visible only when the camera is moved from its default position.

Colour pot Select a custom colour for the grid.

NOTE The Action grid is independent from the global grid in the Grids and Guides menu.

Resize Back box Resizes the background using either a Fill, Crop Edges, Letterbox, or Crop Centre resizing. Affects Colour Corrector and Keyer operations on media, to temporarily provide them with the proper resolution when you enter these modules. This option does *not* affect the render.

Back Fill Quality box Determines the quality of the resize defined in the Resize Back box.

Ortho Near Adjust the near view in the image window when using Camera or an orthographic view.

Ortho Far Adjust the far view in the image window when using Camera or an orthographic view.

3D Cloud button Enable to display 3D points in your image after performing a 3D auto track analysis. You can also use the hot key **Alt+D** to turn this button on or off from any Action menu.

Schematic Settings

Use these settings to define how you work in the Action schematic.

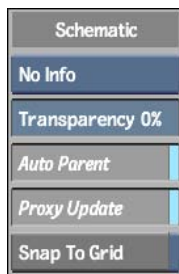

Display Info box Lets you select whether to display resolution, framerate, size, or any combination of information in the Schematic view.

Schematic Transparency field Makes unselected nodes appear transparent in the Schematic view.

Auto Parent button Enables automatic parenting in the schematic. Press **Alt** and drag a node in the schematic to disable Auto Parent temporarily.

Proxy Update button Activates automatic updating of proxies in the Schematic view. Interaction is slower when this button is enabled.

When Proxy is disabled, Action updates proxies when you switch views. You can also update proxies by clicking Update.

Snap To Grid button Enable to position objects with precision in the scene. When you move an object in the scene, the object is automatically aligned to the snap grid.

NOTE When enabled, this snap only applies to the grid defined in Action. The grid defined from the Grid & Guides menu remains visible, but its snap is overridden as long as the Action Snap is enabled.

Saving, Loading, and Importing

You can save, load, and import Action setups.

When loading a DVE setup from a previous version of Fire or Smoke, Action translates the elements to create a comparable scene. For example, in a saved DVE setup, if the front axis of a layer is not modified, it is not created by default in Action.

When importing a setup into Smoke that was saved in Inferno, Flame, or Flint, all non-supported objects (such as particles and deformations) are displayed as greyed out nodes in the schematic, and greyed out menus in the Object menu. These greyed out objects are read-only objects that can be viewed in Smoke (in the image window and the Object menu), but not modified or linked to or from. In Channels view, you can view the parent channel for the non-supported object, and in Tracks view, you can slide or stretch the parent

channel. If you modify the setup in Smoke and resave it, you can open it in Inferno, Flame, or Flint, and modify all objects.

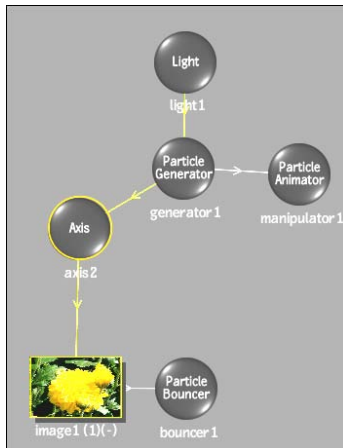

Schematic of Inferno, Flame, or Flint setup

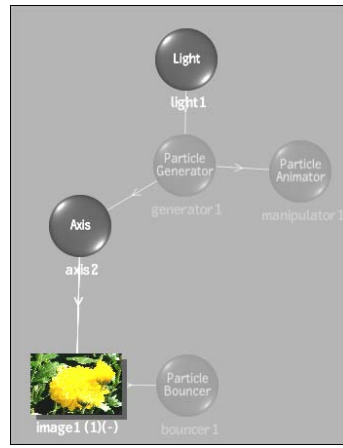

Schematic of same setup opened in Smoke

To save an Action setup:

- 1 Click Save.



The file browser and Save menu appear.

- 2 From the Save Action box, select the format for saving the setup.

Select:	To save:
All	References to all clips in the Media list.
Raw	<p>Selected animation channels as a user-readable ASCII file. In the file, each line corresponds to one frame, and each column consists of one frame number and the value of the animation curve at that frame. All saved information starts at frame one.</p> <p>A file with the extension <code>.raw</code> is saved in the <code>.../action</code> directory by default. At least one channel must be selected in the Channel Editor.</p>

Select:	To save:
Text	The current text settings, including font, character size, kerning, italics, depth, beveling curve, and text string properties, all of which can be loaded in another Action session. A file with the extension <i>.atext</i> is saved in the <i>.../action</i> directory by default. A 3D text node must be selected in the schematic.
Preferences	The current Action settings as user preferences. A file with the extension <i>.pref</i> is saved in the <i>/usr/discreet/user/flame/user_name/action/pref</i> directory.
Defaults	The current Action preferences as Action's new default settings. To restore Action's factory default settings, select Factory Defaults in the Load menu.
Multitrack	A multilayer setup for all Action media and save a multitrack clip in the current library.

- 3 Type a name for the setup file and click Enter.

The name appears in the Name field.

By default, the setup is saved in the */usr/discreet/project/flame/action* directory. Using the file browser, you can save setups to the directory of your choice.

- 4 Once you have saved an Action setup, you can quickly resave it by clicking Save again.

TIP Click Revert to revert to the last saved setup. All changes made since the previous Save operation are undone.

To load a setup in Action:

- 1 Click Load.



The file browser and Load menu appear.

NOTE When you access the file browser through Load, you also have the option of removing existing setups.

2 In the Load box, select the format for loading the setup.

Select:	To:
All	Load the clips in the selected setup into their corresponding media. The media in the Media list is replaced with the loaded clips. If a clip cannot be found on the Desktop, Action searches for it in the clip library and loads it automatically to Action and to the Desktop. If the clip still cannot be found, Action displays the missing clip name in red in the Media list. A surface that uses a missing clip appears as an outline in the image area and is shown in red in Schematic view.
No Clips	Load a setup without its clips. The current media in the Media list remains the same.
Add Nodes+Media	Add nodes and media from the setup file. This option appends the schematic and Media list from the setup file to the current schematic and Media list.
Add Nodes	Add only the nodes from the setup file. This option appends the schematic from the setup file to the current schematic. Not supported when loading a DVE setup from previous releases of Smoke or Fire.
Multitrack	Load a multitrack setup. Loads front, matte, back, and background video tracks from an entire clip. Replaces all media.
Raw	Load raw animation data to a selected channel in the Channel Editor.
Text	Load the text setup files. The text settings are loaded into Action's Text menu. To create a 3D text object from loaded settings, click Create in the Text menu. See Creating 3D Text on page 2300.
Preferences	Load a file containing Action preferences.
Factory Defaults	Load original Action default settings. Selecting this option prompts you to confirm that you want to restore factory defaults and returns you to the Action menu.

3 Click Context to filter the file types listed in the browser.

Only the files types that correspond to the selected load option are listed in the browser.

4 Select the setup you want to load.

NOTE Sample Action setups are provided in the *~/examples/action* directory.

- 5 Click Load.

The selected setup is loaded into Action.

To remove an Action setup:

- 1 Click Load.

The file browser and Load menu appear.

- 2 In the file browser, select the setup you want to remove.
- 3 Click Remove, and when prompted, click Confirm.

To import a file into Action:

- 1 In the Setup menu, click Import.

The file browser and Import menu appear.

- 2 From the Import box, select the file format you want to import.
- 3 In the file browser, select the file you want to import.

Importing Photoshop Files into Action

You can import Adobe Photoshop format files into Action without having to convert them into a TIFF or other format. Once imported, the PSD file keeps its inherent layer structure, which can be used or modified within Flame.

You also have the option of automatically importing all the layers at their native resolution. Each layer is parented by an axis that gives it the correct offset in the X and Y axes. Hidden layers are imported, but will remain hidden. When possible, Action blend modes are used to simulate the Photoshop blend modes, such as blur and multiply.

To import a PSD file into Action:

- 1 From the Action Node bin, double-click the Import node.
The file browser appears.
- 2 From the Import Type box, select the Photoshop format.



- 3 Select a *.psd* format file.
- 4 Click Load.

The Photoshop file is loaded into Action. Each layer is parented by an axis, and blend modes are simulated. A reel is also created in the current clip library with the name of the Photoshop file, and all of the Photoshop layers saved to it.

NOTE If the current clip library is read only, a warning appears indicating that the PSD file can be imported, but the clips are not saved to the clip library.

Topics in this chapter:

- [About Media](#) on page 2133
- [Accessing the Media Menu](#) on page 2134
- [Adding Media](#) on page 2137
- [Viewing Media](#) on page 2138
- [Modifying Media](#) on page 2141
- [Adding Effects to Media](#) on page 2145
- [Accessing the Colour Corrector and the Keyer from Action](#) on page 2150
- [Accessing the Modular Keyer from Action](#) on page 2152

About Media

You should have a working understanding of Action media and the relationship between media and surfaces to be successful in using Action. Media has the following characteristics:

- Each front and matte clip combination that you load from the Desktop is called *media*.
- The clips you load into Action are listed in the Media list.
- When you first open Action, you load the front clip and matte clip for the first media and a common back clip for all media.

- Media must have a front and matte of the same resolution, but each media can have a different resolution from the other.
- You can work with front only or matte only media. In this case, the empty front or matte is replaced with an internal white frame of the same resolution.
- The same media can be applied to multiple surfaces. Any cropping, blurring, or recolouring that you apply to one instance of media is applied to all the surfaces for that media. For example, if you blur media, all of the surfaces using that media are blurred.

Media Workflow

The following table shows the recommended workflow when working with media in the Action module.

Step:	Refer to:
1. Select an initial front, matte and back clip.	Accessing the Action Module on page 2089.
2. Add media.	Adding Media on page 2137.
3. Apply media to a surface.	Applying Media to Surfaces on page 2179.
4. Colour correct or key media.	Accessing the Colour Corrector and the Keyer from Action on page 2150.

Accessing the Media Menu

When you open Action, you load the front and matte clips for the first media. You can then load any additional media. Use the Media menu to modify the front and matte clips.

The clips that you load for each media appear in the Media list. The back clip you selected to access Action appears in the first row of the Media list and is assigned the letter B in the # column. The second row in the Media list contains the first front and matte clips you selected when accessing Action. The length of each clip appears in parentheses beside the clip name. A new line is added to the Media list each time you add media.

You can sort the Media list by list number, front clip name, or matte clip name. As you view clips, you can look at the original front, back, or matte clip individually, as well as the results of colour correcting and keying a matte.

To access the Media menu, click Media in the Action menu. To help identify media, **Alt+click** a surface in schematic, result, or camera view to automatically select the media in the Media list. If the Media menu is not selected, press **Alt** and double-click the surface to switch to the Media menu, and automatically select the media in the Media list. Also, when you select multiple surfaces, you can press **Alt** to select all associated media in the Media list. In this case, the first item selected is framed in yellow in the Media list as the current selection.

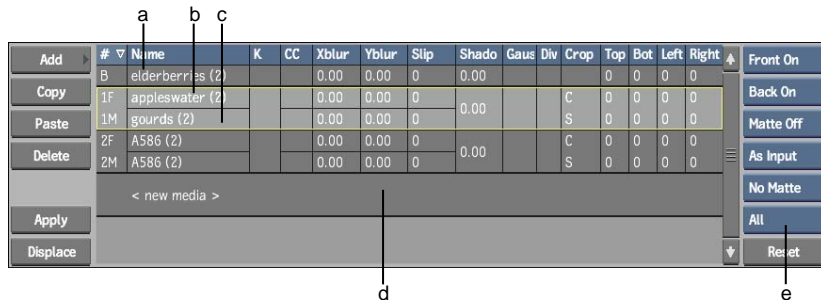

(a) Back media (b) Front media (c) Matte media (d) New media line (e) Reset box

The Media controls are described as follows.

Add button Adds media. Select the New media line and then click Add. You are prompted to select front, matte, or front and matte clips from the Desktop. See [Adding Media](#) on page 2137.

Copy and Paste buttons Copy media parameters to another media. See [Copying Media Settings](#) on page 2142.

Delete button Deletes media from the Media list. See [Deleting Media](#) on page 2143.

Apply button Applies media to a surface. See [Applying Media to Surfaces](#) on page 2179.

Displace button Specifies the media to use as the displacement source when you use displacement mapping to create a 3D object from a 2D surface. See [Using Different Media for the Displacement Source](#) on page 2201.

Reset button and box Resets media properties. Use the Reset box to select the properties you want to reset, then click Reset.

Keyer (or Modular Keyer) field Loads the back, front, and matte clips for the selected media into the Keyer or Modular Keyer. See [Accessing the Colour Corrector and the Keyer from Action](#) on page 2150 or [Accessing the Modular Keyer from Action](#) on page 2152.

You can set the default keyer with the MK As Default toggle button in the Action Setup menu.

CC fields Loads the clip for the selected media into the Colour Corrector. See [Accessing the Colour Corrector and the Keyer from Action](#) on page 2150.

Xblur and Yblur fields Adjusts the amount of Gaussian or Box blur along the X and Y axes.

Slip fields Slips the back, front, or matte clip. See [Slipping Media](#) on page 2149.

Shadow fields Adjusts the softness of a shadow. If the scene contains more than one shadow using the selected media, all shadows are softened by the same amount you specify in this field. See [Adding Shadows](#) on page 2202.

Gaussian fields Uses Gaussian blur on a selected media. See [Blurring a Clip](#) on page 2146.

Divide fields Divides the front media by its associated matte media. See [Eliminating Unwanted Black in Areas of Media Transparency](#) on page 2149.

Crop and Crop Softness fields Crops a front clip or a matte clip for a selected media. Use the Top, Bottom, Left, and Right fields to crop the selected sides. You can also add crop softness. See [Cropping a Clip](#) on page 2147.

Media Menu Shortcuts

Use hot keys and shortcuts when working with clips and media in the Media menu.

- Different colours and shades are used as visual cues within the Media menu. The current media is outlined in yellow, and the selected media is highlighted in light grey. Selected fields of the media are highlighted in grey.
- **Ctrl**-click fields or media to add to a selection, or **Shift**-click to add a range to a selection. If you **Ctrl**-click a field that is already selected, all selected fields of this type in other selected media become deselected. However, if you continue to press **Ctrl**, you can then click any field, and all fields of the same type in other selected media become selected.

- Click a numeric field to display the calculator, or click and drag to increase or decrease the value in a field.
- **Ctrl+Alt**-click a field to reset the field.
- Double-click the Gaussian, Divide, Crop, or Crop Softness field to toggle the effect on or off. Press **Shift** while double-clicking to apply the toggle to all selected media.
- Double-click a Module field (Keyer, MK, or CC) to enter its module. Press **Alt** and double-click the Keyer field to enter the non-default keyer (Keyer or Modular Keyer).
- Click a front media to select all the displayed fields, as well as Front mode.
- Click a matte media to select all the displayed fields, as well as Matte mode and Process Alpha mode.
- Use the **F** hot key to toggle the matte media display in the Media list on or off. You can also set this behaviour with the Edit Front Only toggle button in the Action Setup menu.
- Resize the column widths in the Media menu by dragging the column dividers.

Adding Media

As the complexity of your effects grows, so will the amount of media you use. You can add unlimited media; media is added to the Media list as they are created. If Auto Image is selected in the Action Setup menu, an image node and axis are also created in the schematic when new media is added.

To add media:

- 1 In the Media menu, click <new media> from the New Media line.

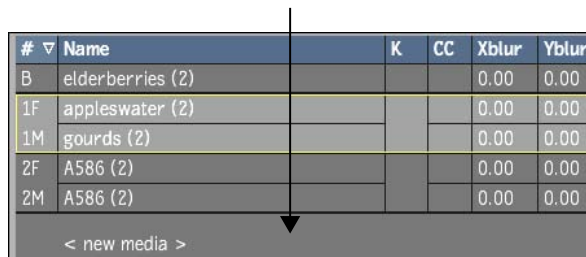

#	▽ Name	K	CC	Xblur	Yblur
B	elderberries (2)			0.00	0.00
1F	appleswater (2)			0.00	0.00
1M	gourds (2)			0.00	0.00
2F	A586 (2)			0.00	0.00
2M	A586 (2)			0.00	0.00
< new media >					

- 2 Click Add to return to the Desktop.

TIP You can also double-click the <new media> line in the Media list to return to the Desktop.

- 3 From the Desktop, select a front and matte clip to load as media. You are also given the option to create and select coloured frames, or to enter the clip library to select clips.

Selecting media that already contains a front and/or matte and clicking Add will replace the clips contained in the media.

NOTE You can select any number of front and matte clips by holding the **Ctrl** key while selecting clips. Each front/matte selection is added to its own line in the Media list, and image nodes are automatically added to the schematic if Auto Image or Auto DVE is selected in the Setup menu.

- 4 Repeat these steps to add more media.

NOTE After adding media, if the front or matte can no longer be found on the Desktop or clip library, the name of the front or matte media is displayed in red in the Media list, and the missing front or matte acts as a white frame in Action.

Viewing Media

As you work with media, you can set properties for either the front, matte, or back clip. To view a clip exclusively, you can select it from the View box. View attributes are set per media.

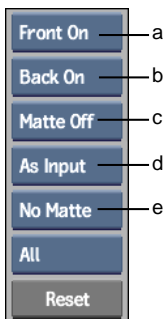

(a) Front Clip box (b) Back Clip box (c) Matte Clip box (d) Media Rendering box
(e) Matte Output box

Media Rendering box Sets the rendering for each media. Select Interlaced, Progressive, or As Input (to render using the mode that corresponds to the source clip).

Matte Output box Determines if a matte will be output for a selected media or for the entire scene. See [Processing a Matte](#) on page 2144.

To enable a clip, select On from the applicable Clip box. To disable a clip, select Off. You may want to disable a clip in the following situations:

- Disable the back clip to use a solid black background in the animation.
- Disable the matte clip to work with the full-front image. To work with a cutout of the front image, make sure that the matte clip is enabled.

To edit a front clip's visibility:

- 1 Select media from the Media list.
- 2 From the Front Clip box, select one of the following options.

Select:	To:
Front On	Display the front clip for the selected media.
Front Off	Hide the front clip for the selected media.
Front Lock	Lock the selected front clip at the current frame in the timebar. See Locking the Front or Back Clip on page 2142.

To edit a back clip's visibility:

- 1 From the Back Clip box, select one of the following options.

Select:	To:
Back On	Display the back clip.
Back Off	Hide the back clip.
Back Lock	Lock the back clip at the current frame in the timebar. See Locking the Front or Back Clip on page 2142.

To edit a matte clip's visibility:

- 1 Select media from the Media list.

2 From a Matte Clip box, select one of the following options.

Select:	To:
Matte On	Display the matte clip for the selected media.
Matte Off	Hide the matte clip for the selected media.
Matte Invert	Invert a matte. Black areas will be made white, and white areas will become black.

TIP To invert multiple matte clips, **Ctrl-click** the matte media and select Invert in the Matte Clip box.

To display a clip in the image window:

1 Select the corresponding view from the View box.

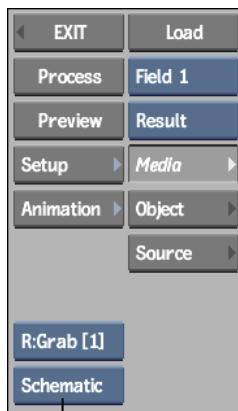

(a) View box

Select:	To display:
Media Front	The front clip.
Media Matte	The matte clip.
Media Back	The back clip.
Result	The overall effect.

NOTE The selected clip is also displayed as an Image node in the Node bin. You can also display media clips by selecting Medialist from the View box, or by touching the swipe bar on the left of the Media menu.

Modifying Media

You can modify media to contribute to your overall effect. Media can be replaced, hidden, locked, copied, or deleted.

Changing Media Clips

You may decide to change the front and matte clips that make up media. You can easily replace media with any set of front and matte clips from the Desktop.

To change media:

- 1 In Action, click Media.
- 2 Double-click the media that you want to change in the # column.
The Desktop appears.

TIP To load only a front or matte clip, double-click the corresponding front or matte field in the Name column. In this case, the empty front or matte is replaced with an internal white frame of the same resolution.

- 3 Select a front clip and a matte clip.
You return to the Media menu. The names of the new clips replace those of the old clips in the Media list. The new clips are applied to all the media's surfaces.

To change the back clip:

- 1 In Action, click Media.
- 2 Double-click the B field in the # column.
The Desktop appears.
- 3 Select a clip for the back clip.

Locking the Front or Back Clip

Normally when you use the image window controls to move through the front or back clip, each frame of the clip is loaded and appears in sequence in the image window. You can change this default setting so that the frame displayed is not updated as you move through the clip, but remains locked at a specific frame.

To lock the front or matte clip:

- 1 Optional: Click Media Front to display the clip in the image window.
- 2 In the timebar, choose the frame at which you want to lock the clip. This frame becomes the current frame for the clip.
- 3 In the Front clip box, select Lock.

NOTE The matte is automatically locked when the front lock is enabled.

- 4 Click Result to view the resulting clip in the image window. The front clip remains locked to the current frame.

You lock the back clip in the same way as the front clip, except that you select Lock from the Back Clip box.

The matte clip is locked with the front clip by default. However, you can slip the matte so that it is locked at a different frame. Use the Slip field to set the slip value for the selected matte clip.

Copying Media Settings

You can copy your current media settings to other media.

To copy media:

- 1 Select the media that you want to copy from the Media list.
- 2 Click Copy.

Add	#	Name	K	CC	Xblur
	B	elderberries (2)			0.00
Copy	1F	appleswater (2)			0.00
Paste	1M	gourds (2)			0.00
	2F	A586 (2)			0.00
Delete	2M	A586 (2)			0.00
< new media >					
Apply					
Displace					

All parameters of the current media are copied.

- 3 In the Media list, select a line or lines where you want to paste the copied media.
- 4 Click Paste.
The copied parameters are pasted to all selected fields.

Deleting Media

You can delete media applied to surfaces. When you delete media, the surface becomes invisible and the media is empty. You can then apply another media to the surface, add a new front and matte clip media, or delete the surface.

To delete media:

- 1 In Action, click Media.
- 2 In the Media list, select the media that you want to delete.
Hold **Ctrl** and click to select multiple media lines. Alternatively, hold **Shift** and click to select a consecutive range of media.
- 3 Click Delete.

Add ▾	# ▾	Name	K	CC	Xblur
	B	elderberries (2)			0.00
Copy	1F	appleswater (2)			0.00
Paste	1M	gourds (2)			0.00
Delete	2F	A586 (2)			0.00
	2M	A586 (2)			0.00
< new media >					
Apply					
Displace					

You are prompted to confirm the deletion operation. Click anywhere in the menu to cancel the delete operation. You cannot undo a deleted media operation.

Processing a Matte

It is possible to output a matte for a selected media or for the entire scene. Use the Matte Output option box in the Media list to select between outputting no matte, a media's matte, or a scene matte.

NOTE In Batch, the Action node has two outputs, one result and one matte.

To process a media's matte:

- 1 Select media from the Media list.
- 2 Position the timebar where you want to begin processing the matte.
- 3 Select an option from the Matte Output box.

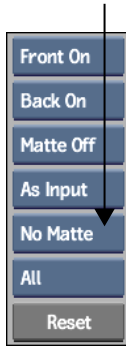

Select:	To Output:
No Matte	No mattes for the scene or media (default).
Media-Matte	A single media's matte. Grabs the media's processed matte and copies it directly to a frame buffer. Transformations to the media are not computed when processing the matte.
Scene-Matte	A matte of the entire scene for selected media. If you select multiple media lines in the Media list, and select Scene Matte, you can output a combination matte for the selected media. 3D Geometries and particles are also output.
Blend-Matte	A matte of the entire scene for selected media, but use the normal blend mode to respect a scene's transparencies.

4 Click Process.

The newly processed matte is placed on the Desktop.

NOTE Processing a SceneMatte may increase render times.

Adding Effects to Media

The Media list allows you to easily add and edit effects to your clips, such as blurs and crops.

Blurring a Clip

To blur the front, matte clip, or back clip for the selected media, use the Xblur and Yblur fields. The Xblur field controls the amount of blurring on the horizontal (X) axis, and the Yblur field controls the amount of blurring on the vertical (Y) axis.

NOTE If you apply the media to more than one surface, all the surfaces are blurred.

#	Name	K	CC	Xblur	Yblur	Slip	Shado	Gaussi	Divide
B	elderberries (2)			0.00	0.00	0	0.00		
1F	appleswater (2) (A)			7.00	6.00	3	5.00	<input checked="" type="checkbox"/>	<input checked="" type="checkbox"/>
1M	gourds (2) (A)			3.00	5.00	7			
2F	A586 (2)			0.00	0.00	0	5.00		
2M	A586 (2)			0.00	0.00	0			

(a) Xblur (b) Yblur (c) Gaussian Blur

You can use a Gaussian (Gaussian enabled) or a Box blur (Gaussian disabled):

- Gaussian blur has rounded, smoother edges. It is a better blur for animation because it can be blurred on a subpixel level (0.00).
- Box blur has rectangular, rougher edges.

To blur the front clip of media:

- 1 In Action, click Media.
- 2 Select the front media.
- 3 To use a Gaussian blur, double-click the Gaussian field (otherwise a Box blur is applied).
- 4 Set the blur using the Xblur and Yblur values, and then negate the values for the Blur fields on the matte media. For example, to blur only the front clip 10 pixels on both axes, set the front Xblur and Yblur fields to 10 and the matte Xblur and Yblur fields to -10.

TIP Alt-drag over the XBlur or YBlur field to change both values proportionally.

To blur the matte clip of media:

- 1 In Action, click Media.
- 2 Select the matte media.
- 3 To use a Gaussian blur, double-click the Gaussian field (otherwise a Box blur is applied).
- 4 Set the matte Xblur and Yblur fields. Blurring only the matte clip produces a softer edge on the surface of the front clip.

TIP Alt-drag over the Xblur or Yblur field to change both values proportionally.

Cropping a Clip

When you crop media, the front and matte clips are cropped together. You cannot crop the back clip. If you applied the media to more than one surface, all the surfaces are cropped.

You can animate a crop by changing the size and shape of the Crop box at different keyframes. You can also animate the softness of the Crop box.

NOTE Animating a crop in the Channel Editor does not enable the Crop field in the Media list.

To crop a clip with the Media list:

- 1 In Action, click Media.
- 2 Set values for cropping and softness in the Top, Bottom, Left, and Right fields. Once you set a value in one of the Crop or Softness fields, a checkmark indicates that Crop or Softness is enabled.

	Crop	Top	Bottom	Left	Right
		0	0	0	0
b	C ✓	5	5	10	10
a	S ✓	0	0	85	52
	C	0	0	0	0
	S	0	0	0	0

(a) Softness area of Crop field (b) Crop area of Crop field

TIP Alt-drag over one of the fields to change all four values proportionally.

To crop gesturally in the image window:

- 1 Double-click the top portion of the Crop field to enable Crop and double-click the bottom portion of the Crop field to enable crop softness.
- 2 In the View box, select Media Front or Media Matte.
The clip appears in the image window with a red outline, which indicates the Crop box, and a green outline, which indicates the Softness box.

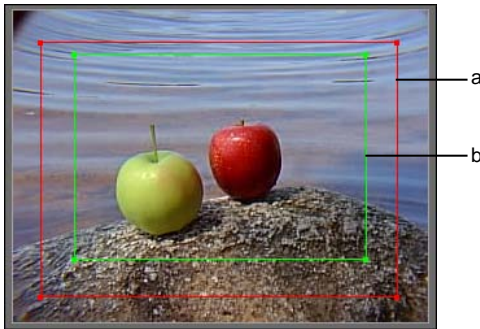

(a) Crop box (b) Softness box

TIP You can use two viewports to view the crop interactively on both the front and the matte clips.

- 3 Set the corners of the Crop box and Softness box by dragging either the corners or edges of the red and green outlines.
The crop and softness values in the Media list are updated as you drag.
- 4 Click Result.
The cropped media appears in the image window, and the front and matte clip share the same crop.

Eliminating Unwanted Black in Areas of Media Transparency

When compositing with images generated by rendering 3D objects over a black background, unwanted black often appears on translucent or anti-aliased areas of the media. Use the Divide tool to divide the front media by its associated matte media, which eliminates the black edges in the composite.

To remove unwanted black in media transparency:

- 1 In Action, click Media.
- 2 In the Media list, select the media containing the unwanted black.
- 3 Double-click the Divide field of the media containing the unwanted black.

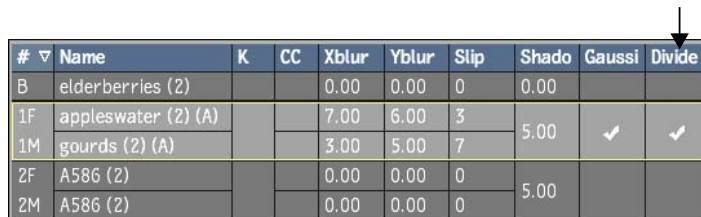

# ▾	Name	K	CC	Xblur	Yblur	Slip	Shado	Gaussi	Divide
B	elderberries (2)			0.00	0.00	0	0.00		
1F	appleswater (2) (A)			7.00	6.00	3	5.00	✓	✓
1M	gourds (2) (A)			3.00	5.00	7			
2F	A586 (2)			0.00	0.00	0	5.00		
2M	A586 (2)			0.00	0.00	0			

The selected media's front is divided by its matte, resulting in correct colour in areas of transparency.

Slipping Media

You can animate the Slip value of a media's front, matte or background clip. Do this to begin a clip at a specified frame number, or to produce a freeze frame effect where the first frame is held for a specified number of frames. In addition, Slip values are animatable for all types of clips.

If you want to animate the Slip values, or control the Front Slip and Matte Slip separately, use the Channel Editor. The channels are found in their respective media and are named Slip and slip_matte. The Background Slip channel is found in Scene>Media>Background>Slip. For more information, see [Accessing the Channel Editor](#) on page 1964.

To slip media:

- 1 In Action, click Media.

- 2 Change the value of Slip for either the Front or Matte fields, or both, of the media you want to slip.

TIP Alt-drag over the Front or Matte slip field to change both while maintaining the same offset.

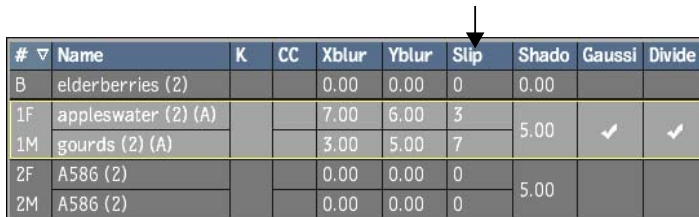

The image shows a table with columns: #, Name, K, CC, Xblur, Yblur, Slip, Shado, Gaussi, and Divide. An arrow points to the Slip column. The table contains the following data:

#	Name	K	CC	Xblur	Yblur	Slip	Shado	Gaussi	Divide
B	elderberries (2)			0.00	0.00	0	0.00		
1F	appleswater (2) (A)			7.00	6.00	3	5.00	✓	✓
1M	gourds (2) (A)			3.00	5.00	7			
2F	A586 (2)			0.00	0.00	0	5.00		
2M	A586 (2)			0.00	0.00	0			

A positive value starts the clip at the specified frame. A negative value creates a freeze frame effect where the first frame of the clip is held by the specified number of frames.

To slip a background clip:

- 1 Change the value of the B (background) Slip field.

Accessing the Colour Corrector and the Keyer from Action

By accessing the Keyer and the Colour Corrector directly from Action, you can key any media or colour correct any front, matte, or back clip without having to exit to the Desktop.

When you enter the Colour Corrector or Keyer from Action, you can view the result of your colour correction or key as it would appear in Action using the Context button. The Context view is interactive; as you make changes, the Action result is updated in the image window.

As you use more media in Action, interactivity in the Colour Corrector and Keyer may be slower than when you access the modules exclusively from the Desktop. However, accessing these modules through Action is more efficient for checking your changes against the other Action media.

Use Result view while keying or colour correcting. In this way, the number of Action media has no impact on system performance. You can tweak the keying and colour correction setup using Context view.

While you work in the Colour Corrector or Keyer, you do not have to click Process; the modifications are automatically applied to the media in Action. If you enter the Colour Corrector from Action, scrub the timebar to view the Result.

NOTE When loading Action setups that contain CC or Keyer effects from a previous version, you may experience a slight loss of quality when viewing proxies. To avoid this loss of quality, select Proxy Full from the Action Setup menu.

To access other modules from Action:

- 1 In Action, click Media.
- 2 Double-click the corresponding field for your chosen media and module. For example, to colour correct the matte clip, double-click the matte CC field.

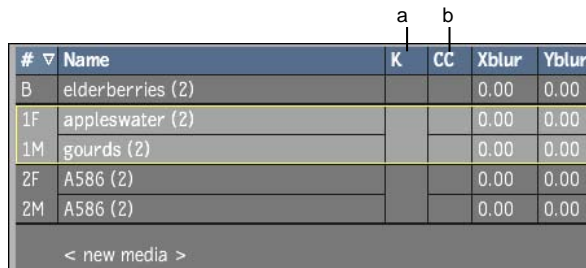

# ▾	Name	K	CC	Xblur	Yblur
B	elderberries (2)			0.00	0.00
1F	appleswater (2)			0.00	0.00
1M	gourds (2)			0.00	0.00
2F	A586 (2)			0.00	0.00
2M	A586 (2)			0.00	0.00
< new media >					

(a) Keyer (b) Colour Corrector

TIP You can set the default keyer to Keyer or Modular Keyer in the Action Setup menu, or press **Ctrl** and double-click the Keyer field to enter the non-default keyer (Keyer or Modular Keyer).

- 3 As you work in the module, click Context to preview the result.
- 4 Click Exit to return to Action.

NOTE When working with 12-bit clips in the Colour Corrector, Modular Keyer, or Keyer, you create a new setup at 12 bits. If you return to Action and work at proxy resolution, the setups are scaled to 8 bits (along with the proxies) and 4 bits of colour are lost. However, if you switch to proxies once you return to Action, a copy of the 12-bit setup is stored and restored when you are ready to process at full resolution.

Muting Media Effects

You can mute Keyer and Colour Corrector media effects in the Action Media menu. Muting effect media can be helpful when you want to see what your Action setup looks like without the Keyer or Colour Corrector settings, but not lose any of the settings of the muted media effect.

To mute an effect, press **Alt** and click the K (or MK) or CC media. The check mark in the field turns black to signify the media effect is muted. To unmute the media effect, press **Alt** and click the field again.

#	Name	K	CC
B	elderberries (2)		
1F	appleswater (2) (A)		✓
1M	gourds (2) (A)		
2F	A586 (2)		✓
2M	A586 (2)		

(a) Active media effect (b) Muted media effect

Accessing the Modular Keyer from Action

There are some minor differences when you access the Modular Keyer from Action instead of from the desktop. This section describes features specific to using the Modular Keyer in Action. For complete information on using the Modular Keyer, see [Modular Keyer](#) on page 1603.

When you load media into the Modular Keyer, the front and matte clips for the selected media are loaded with the back clip and appear at the beginning of the processing pipeline. The front clip is used as the front clip and the matte clip is used as the Key In clip for the processing pipeline.

The back clip is used as the back clip in the processing pipeline and is loaded as a reference only. Any modifications you make to the back clip in the Modular Keyer are not used when you return to Action.

To view the results of your Modular Keyer work as it would appear in Action, select ActionRes from the Alt View box.

The following example shows media loaded into the Modular Keyer from Action.

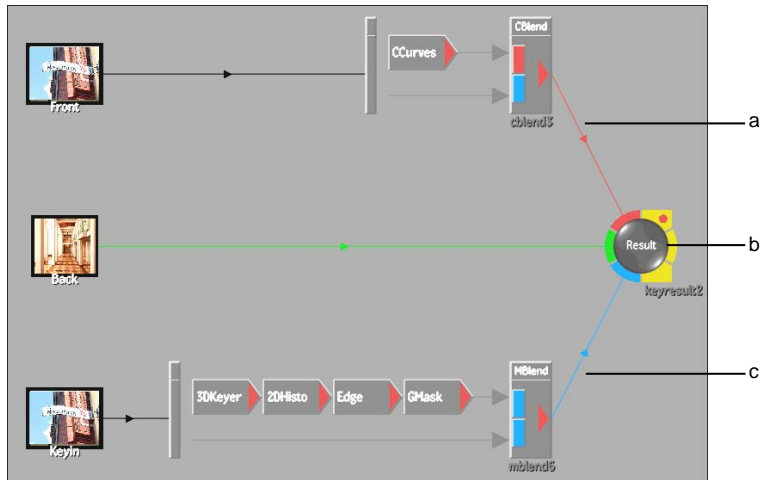

(a) The colour-corrected front clip is returned to Action. (b) The matte curves for the Result node are returned to Action. (c) The matte is returned to Action.

All branches in the processing pipeline are connected to the Result node. When you return to Action from the Modular Keyer, the following information is used:

- The colour-corrected front clip (attached to the red tab of the Result node)
- The matte clip (attached to the blue tab of the Result node)
- The matte curves for the Result node (To access the matte curves, click the Result node.)

NOTE The back clip is for reference only. Any modifications you make to the back clip, such as colour correction, are not applied in Action.

Action: DVE Layer Objects

71

Topics in this chapter:

- [About DVE Layer Objects](#) on page 2155
- [Adding a DVE Layer Object](#) on page 2156
- [Navigating with DVE Layer Objects](#) on page 2157
- [Modifying DVE Layer Objects](#) on page 2159
- [Replacing a DVE Layer Object's Clip with Another](#) on page 2163

About DVE Layer Objects

DVE Layer Objects emulate the axis and surface structure of DVE clip layers from earlier versions of Smoke and Fire. When you add a DVE Layer Object, a single object node is added to the scene comprised of five axes, as well as front and matte sources, and image and shadow surfaces. You can work with the DVE Layer Object as a grouped object in Action. For greater flexibility, you can ungroup the DVE Layer Object to allow for separate manipulation of each axis and surface in the Action schematic.

Adding a DVE Layer Object

You can add DVE Layer Objects automatically when you open Action during a session, or when adding new media, by selecting Auto DVE in the Auto Image option box in the Action Setup menu. You can also add a DVE Layer Object manually from the Action node bin.

To manually add a DVE Layer Object:

- 1 In the Media list, select the media column containing the front and matte that you want to add to the scene. You can also select multiple front and matte columns in the Media list.
- 2 Do one of the following:
 - Drag the DVE Object node from the node bar and place it in the schematic.
 - Double-click the DVE Object node. The node appears next to the last added object. You do not need to be in Schematic view to add a node in this manner.

The DVE Layer Object is added to the scene as a single grouped node, and the Object tabs are populated with all of the objects that comprise the DVE Layer Object (except for Front and Matte sources). If you selected multiple media columns in the Media list, a DVE Layer Object node is added for each.

For information on the specific controls in the Axis menu, see [Manipulating an Object's Axis](#) on page 2169. For details on the specific controls of the Image and Shadow menus, see [Modifying Surfaces](#) on page 2179 and [Adding Shadows](#) on page 2202.

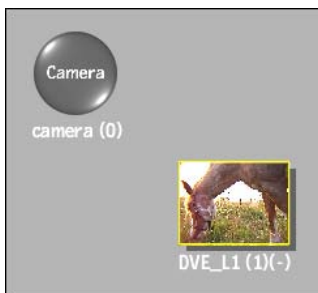

The newly created DVE Layer Object is named according to the media it is created from. For example, DVE_L1 represents a DVE Layer Object created from Layer 1.

NOTE You can add multiple DVE Layer Objects to the Action schematic, but only one per media.

Navigating with DVE Layer Objects

The Action menus help you navigate to the various components of DVE Layer Objects, allowing you to quickly make changes to the objects.

DVE Layers Bar

To help you navigate among multiple DVE Layer Objects, there is a DVE layers bar above the Player controls that contains the list of all the created DVE layers. Each layer has its own tab that you use to select the layer before performing an operation.

Use the arrow buttons to navigate backward or forward among the DVE Layer Objects. The single arrows move forward or backward one item at a time, while the double arrows move forward or backward 15 items at a time.



TIP You can also specify a layer to go to by typing a layer number in the Current Layer field.

Object Tab Navigation

When a DVE Layer Object is selected in the schematic, the tabs in the Object menu are populated with the Main, Offset, Front, Matte, and Shadow Axis menus on the left side, and the image and shadow menus on the right side. These menus allow you to control the various components of the DVE Layer Object.

You can also select DVE Layer Object components directly in the scene. For example, if you select the offset axis in the scene, the Object menu displays all of the menus that comprise the DVE Layer Object, and the Offset axis tab is selected by default.

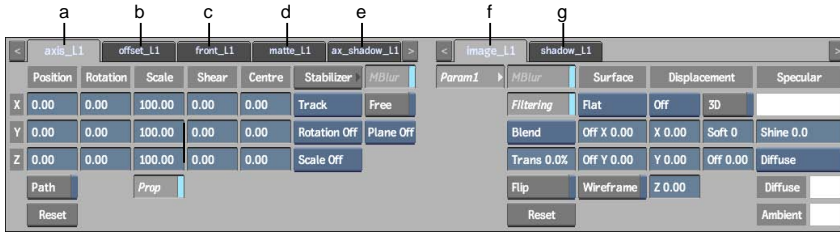

(a) Main Axis tab (b) Offset Axis tab (c) Front Source Axis tab (d) Matte Source Axis tab (e) Shadow Axis tab (f) Surface tab (g) Shadow tab

NOTE You can select multiple DVE Layer Objects in the schematic, and then modify some object settings relatively. When you select multiple DVE Layer Objects, the Object menu tab names change to axes_L, offsets_L, and so on, to reflect the multiple selection.

You can add axes above DVE Layer Objects in Action. If you link an axis above a DVE Layer Object, and select the axis in the schematic, the tab population rules revert to the general Action rules. For example, the following schematic shows a selected axis above a DVE Layer Object.



In this case, the following tabs are populated in the Objects menu.

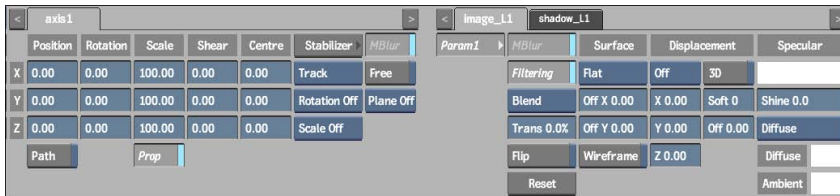

For more information on tab population rules in Action, see [Selecting Objects and Populating Menu Tabs](#) on page 2102.

Resetting Objects

DVE Layer Objects comprise multiple axes and surfaces. You can reset each menu individually, if needed, so that you do not have to reset the complete DVE Layer Object, and potentially lose settings that you want to keep.

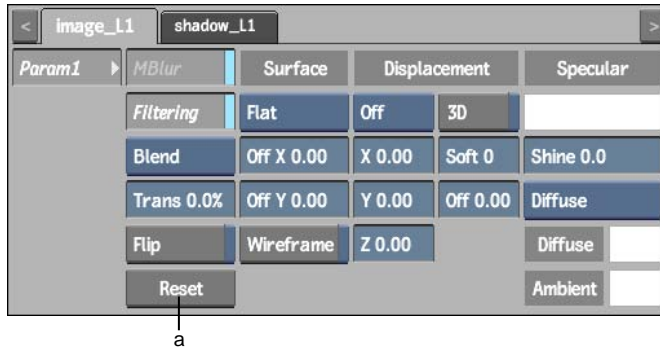

(a) Reset button for specific DVE Layer Object menu

NOTE The DVE Layer Object Shadow surface menu does not have a Reset button, but you can turn the shadow on or off from the Shadow button.

Modifying DVE Layer Objects

When you add a DVE Layer Object to the scene, you can add axes above it, copy it, and perform displacement mapping. You can also expand a DVE Layer Object to reveal its components.

Expanding a DVE Layer Object

You can expand DVE Layer Objects in the schematic. When expanded, the elements that comprise the DVE Layer Object display as Action nodes in the scene. You can work with these nodes as you would any other Action node.

To expand a DVE Layer Object:

- 1 Select the DVE Layer Object in the schematic.
- 2 Click Expand DVE.

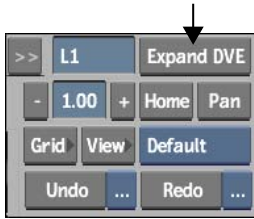

The DVE Layer Object is expanded in the schematic. You can see how the objects that comprise a DVE Layer Object are branched and linked. Each object can now be manipulated as you would any other Action object.



The Front Source branch includes an image node in front-white mode, while the Matte Source branch contains an image node in white-matte mode. By default, Z-buffering is set to Off for DVE Layer Object source nodes to preserve the higher priority of the original matte or front objects. Source nodes inside DVE Layer Objects also use the general anti-aliasing sampling level and softness from the Action Setup menu.

For details on working with source nodes, see [Action: Sources](#) on page 2211.

NOTE If any modifications are made to the expanded nodes, you have to Undo them before you can Undo an Expand DVE operation.

Instancing DVE Layer Objects

You can add multiple axes above a DVE Layer Object. Each axis is a parent of the DVE Layer Object, and the DVE layer is represented in the scene for each axis. You can then use the Axis menu for each axis to manipulate the instance of each DVE Layer Object. In the Object menu, tab names that appear in light blue signify that multiple objects are connected down to it.

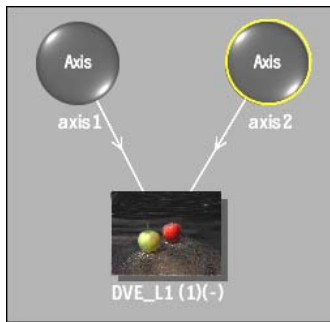

Copying DVE Layer Objects

Use the Copy button to copy a DVE Layer Object to the next available media in the Media list.

To copy a DVE Layer Object:

- 1 In the schematic, select the DVE Layer Object you want to copy.
- 2 From the Selection box, choose Selected.

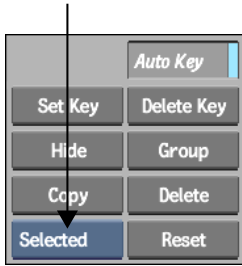

3 Click Copy.

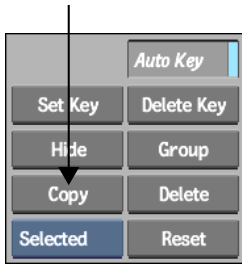

A new DVE Layer Object is created, and is populated with the same components. Any modifications made to the original DVE Layer Object are copied also.

Animating DVE Layer Objects with the Channel Editor

You can animate DVE Layer Objects using the Channel Editor. Click the Animation button to display the Channel Editor.

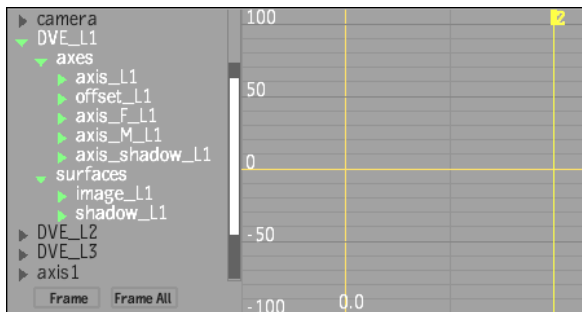

Each DVE Layer Object is displayed as a top-level folder, with subfolders for the axes and surfaces. For complete information about using the Channel Editor and animating objects in the scene, see [Animation](#) on page 1963.

Replacing a DVE Layer Object's Clip with Another

From an expanded DVE Layer Object, you can use Action source nodes to replace a front or matte clip. Instead of expanding a DVE Layer Object, you can use layer re-entry to replace or combine a DVE Layer Object's front and matte clips with the front, matte, or a combination of the front and matte clips from other DVE Layer Objects. Re-entry uses duplicate links internally to maintain the links between re-entered DVE Layer Objects. See [Duplicating Objects](#) on page 2112.

To replace a DVE Layer Object's front or matte clip:

- 1 From the Edit Mode box, select Reentry (or press **Alt+R**).



- 2 To replace a front clip, in the schematic, drag from the DVE Layer Object containing the front clip that you want to replace, to another DVE Layer Object.

A red line indicates the front re-entry link between the two DVE Layer Objects.

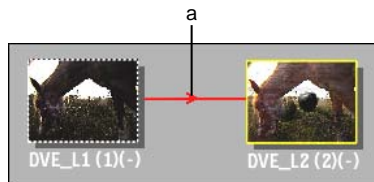

(a) Front re-entry link

- 3 To replace a matte clip, in the schematic, press **Alt** and drag from the DVE Layer Object containing the matte clip that you want to replace, to another DVE Layer Object.

A blue line indicates the matte re-entry link between the two DVE Layer Objects.

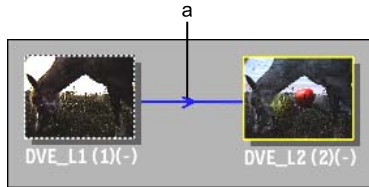

(a) Matte re-entry link

NOTE Multiple front or matte re-entry from the same source is not allowed. For example, DVE_L2 cannot receive front re-entry from another DVE Layer Object if it is already connected to the front of DVE_L1. You can, however, have cascading re-entry. For example, DVE_L2 can be the source DVE Layer Object for DVE_L3, while DVE_L2 receives a re-entry of DVE_L1.

- 4 Use the Object menu to change any of the controls for the newly linked DVE Layer Objects.

Because of the re-entry links between the DVE Layer Objects, the tabs that are displayed in the Axis and Surface menus are different than for a DVE Layer Object without re-entry links. For example, in the following schematic, both front and matte re-entry occur from DVE_L1 to DVE_L2.



The following tabs are displayed in the Object menu when DVE_L2 is selected in the schematic.

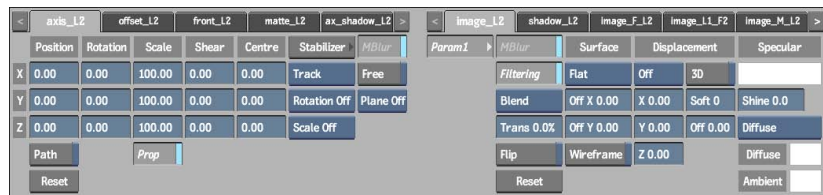

NOTE If there are more than five tabs on either side of the Object menu, use the arrows beside the tab names to navigate to the desired tab.

The axes that control DVE_L1 are not displayed when DVE_L2 is selected in the schematic. To see the DVE_L1 axis controls, select DVE_L1 in the schematic.

Expanding DVE Layer Objects with Re-entry

After you link DVE Layer Objects using re-entry to replace front clips, matte clips, or both, you can expand the linked DVE Layer Objects to reveal all of their components (including front and matte source nodes).

To expand DVE Layer Objects with re-entry:

- 1 In the schematic, select the DVE Layer Object with re-entry applied to it.



- 2 Click Expand DVE.

The schematic displays the expanded scene. Notice the green duplicate links originating from the hidden objects in the DVE_L1 branch.

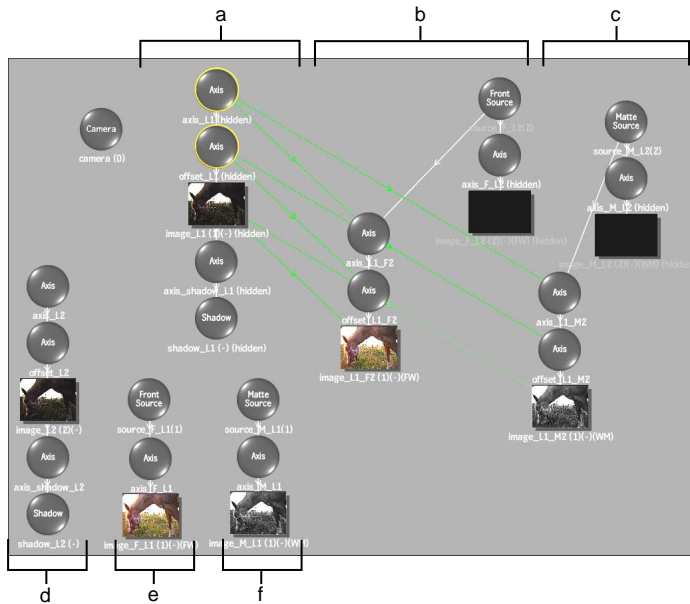

(a) Hidden DVE_L1 branch with duplicate links (b) Front Source branch of DVE_L2 (c) Matte Source branch of DVE_L2 (d) DVE_L2 branch of DVE_L1 (e) Front Source branch of DVE_L1 (f) Matte Source branch of DVE_L1

Reordering Surfaces with Re-entry

You can change the drawing order of the re-entered sources of DVE Layer Objects or nodes parented under re-entered objects using the DVE Re-entry Selection box in the Priority Editor.

To access the Priority Editor, swipe the bar at the bottom of the Media or Object menu.

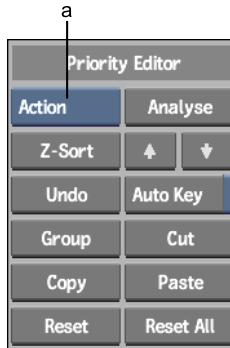

(a) DVE Re-entry Selection box

Depending on how your DVE Layer object is re-entered, you can choose to display the priority of the main scene (Action), or the re-entered Front or Matte source. See [Reordering Surfaces](#) on page 2204 for more information on the Priority Editor.

Limitations of Re-entry with DVE Layer Objects

You cannot add 3D Geometry or 3D Text objects to DVE Layer Objects with re-entry. Use Action's source nodes instead. See [Action: Sources](#) on page 2211.

Topics in this chapter:

- [About Axes](#) on page 2169
- [Manipulating an Object's Axis](#) on page 2169
- [Applying Tracking Data to an Axis](#) on page 2174

About Axes

An axis is the element of an object or media that can be manipulated to determine the object's 2D or 3D space, position, and movement.

Use the scene's X,Y, and Z coordinate system to place each surface in the scene, or to rotate, scale, and shear surfaces. You move, rotate, and animate objects directly in the scene and use the camera to record the scene. The part of the scene that the camera, or frustum, looks at is what gets rendered.

Manipulating an Object's Axis

When you add objects to the scene, such as models or images, they are added with their own axes. Each axis is used to place its respective object in the scene. An axis is represented by the following icon.

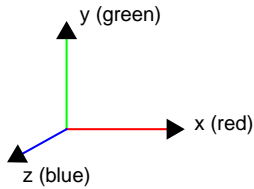

All transformations that you apply to the selected axis are applied to the objects connected to the axis. For example, if the position of a surface's axis is set to 500, 100, 0, then its surface is placed at 500 on the X-axis, 100 on the Y-axis, and 0 on the Z-axis.

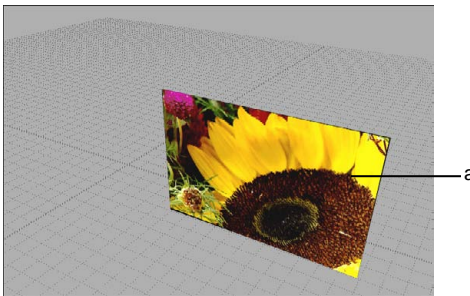

(a) Surface is placed in the scene at 500, 100, 0

The following objects are added with axes:

- All surfaces: Flat, Bilinear, Bicubic, and Extended Bicubic
- Imported 3D models, text, or Paint geometry
- Shadows
- Textures
- Deformations

Action Views

Front, top, and side view are orthographic views used to position an object's axis in the scene. These views are useful for viewing the scene from another angle than the camera's. See [Setting Camera Views](#) on page 2233.

Accessing the Axis Menu

You use the Axis menu to position, rotate, scale, and shear an axis. The Object menu provides tabs so that you can see or modify the parameters of the selected axis. For information about selecting objects and navigating the schematic, see [Selecting Objects and Populating Menu Tabs](#) on page 2102.

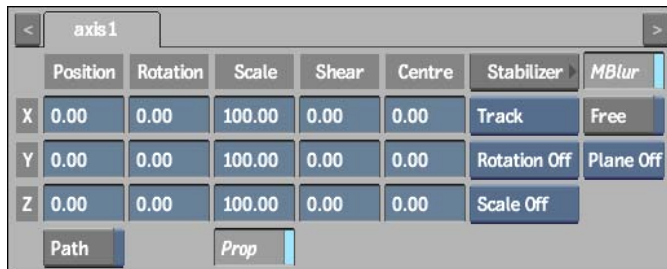

The Axis controls are described as follows.

Position X, Y, and Z fields Translate the selected axis.

Rotation X, Y, and Z fields Rotate the selected axis.

Scaling X, Y, and Z fields Change the size of the axis.

Prop Scale button Scales the X, Y, and Z axes proportionally.

Shear X, Y, and Z fields Shear the axis.

Centre X, Y, and Z fields Offset an axis relative to its children.

Path button Animates the position of the axis using a spline drawn in the scene.

Disable Path to animate the position of the axis using explicit animation. See [Creating a Motion Path](#) on page 2023.

Stabilizer and tracking controls Apply stabilizing data to an axis. See [Applying Tracking Data to an Axis](#) on page 2174.

MBlur button Applies motion blur to the selected axis. See [Applying Motion Blur](#) on page 2237.

Free button Ignores transformations from parent axes.

Plane box Changes the orientation of the plane (in Camera view). See [Changing the Plane](#) on page 2173.

Selecting an Axis

You can select an axis in any of the following ways:

- Click directly on the axis in the scene.

TIP If you have numerous overlapping axes in the scene, press and hold **Q** while clicking to cycle through each axis until the axis you need is selected.

- Go to Schematic view and click the node for the axis.
- Display the Channel Editor and select the Axis folder or one of its channels.
- Use the Prev and Next buttons in the Axis menu to select the previous or next axis.

Moving and Rotating Axes in the Scene

You can move and rotate an axis directly in the scene. You can do this when viewing the scene in Camera, Top, Side, or Front view. See [Setting Camera Views](#) on page 2233.

The selected mode remains in effect until you select a different mode. To select a mode, use the Edit Mode box.



(a) Edit Mode box

Moving an Axis in the Scene

You can move an axis in the scene, as well as objects that do not have exclusive axes such as lights, particle generators, and manipulators.

To move an axis directly in the scene:

- 1 In the Edit Mode box, select Move.
- 2 Select the axis you want to move and drag it to a new position.
If the Axis menu is displayed while you move an axis, you can see the Position X, Y, and Z fields update after the axis is placed in its new

position. You can also change the X, Y, and Z position by dragging any of the position fields in the Axis menu to move the axis.

Rotating an Axis in the Scene

You can rotate an axis in the scene, as well as objects that do not have exclusive axes such as lights, particle generators, and manipulators.

To rotate an axis directly in the scene:

- 1 From the Edit Mode box, select Rotate.
- 2 Select the axis or the object you want to rotate.

A trackball appears in the scene. The trackball consists of three concentric rings. Each ring is used to rotate the object and its axis around one of the three axes.

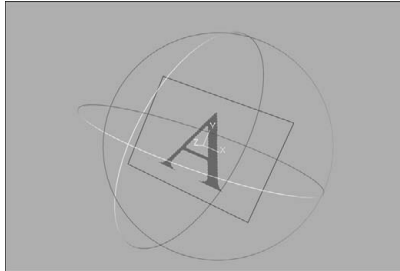

- 3 Click and drag one of the trackball rings.

The axis and its object rotate in the image window. If the Axis menu is displayed while you rotate, you can see the Rotation fields update after the axis is rotated to its new position. You can also rotate the axis by dragging any of the Rotation fields in the Axis menu.

Changing the Plane

When you move an object in the scene, the object moves on a 2D plane. By default, an axis is moved gesturally on all three planes. You can change the orientation of the plane by selecting an option in the Plane box.

For example, if the camera is pointed toward the Y plane and you want to move an axis along the X and Z planes, change the orientation to Plane XZ.

Select:	To move objects:
Plane XY	On the X or Y plane, but not on the Z plane.
Plane XZ	On the X or Z plane, but not on the Y plane.
Plane YZ	On the Y or Z plane, but not on the X plane.
Plane Off	On the X, Y, or Z plane. The plane is oriented to face the camera.

NOTE The different planes can only be used in Camera view. You see the change in the orientation of the plane only when you move the camera away from its default position.

Applying Tracking Data to an Axis

To remove jitter, or track the movement of a feature in the back clip, you can apply tracking data to an axis using the Stabilizer. You can access the Stabilizer directly from the Axis menu in Action.

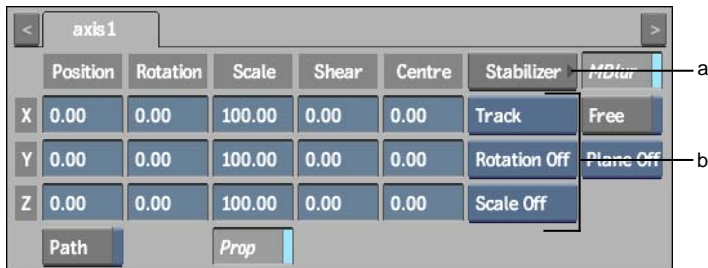

(a) Stabilizer button (b) Tracking Data controls

TIP As you work in the Stabilizer, you can view your tracking result in Action by enabling the Context button in the Stabilizer menu.

Stabilizing an Axis

You can import stabilizing data from the Stabilizer to lock the position of the selected axis to a reference point on the front clip in Action. Any movement in the front clip is matched by the axis. See [Stabilizing](#) on page 1793.

Tracking a Feature in the Back Clip

You can track the movement of a feature in the back clip and apply the tracking data to the selected axis in Action. The axis follows the movement of the feature in the back clip. You can also track the rotation or change in size of the feature. See [One-Point and Two-Point Tracking](#) on page 1800.

Topics in this chapter:

- [About Surfaces](#) on page 2177
- [Adding Surfaces](#) on page 2178
- [Modifying Surfaces](#) on page 2179
- [Editing Tracker Offsets of a Bilinear Surface](#) on page 2190
- [Warping an Extended Bicubic Surface](#) on page 2190
- [Adding a Displacement Map](#) on page 2198
- [Adding Shadows](#) on page 2202
- [Reordering Surfaces](#) on page 2204

About Surfaces

You use surfaces to display media in the scene and then composite front and matte clips with a common back clip.

You should have a working understanding of Action media and the relationship between media and surfaces to be successful in using Action.

A surface is used to place a media in the scene. To use media that you load from the Desktop, you must add a surface to the scene for that media. A surface has the following characteristics:

- A surface type can be flat, bilinear, bicubic, or extended bicubic.

- The same media can be applied to multiple surfaces. Any cropping, blurring, or recolouring that you apply to one media is applied to all the surfaces for that media. For example, if you blur a media, all of the surfaces using that media are blurred.

Adding Surfaces

When you apply media to a surface, you either have to add a new surface or apply media to an existing surface. You can then add displacement and lighting effects, or change the surface's properties such as its shape, transparency, and specular highlight. Once added, the media appears in the Media list.

The first time you open Action during a session, an image surface is added to the scene using the first media (if Auto Image is enabled in the Action Setup menu). You must add a surface for each additional media before its clips can be used in the scene.

You control the position of the surface using axis, rotation, scale, shear, and other attributes related to its placement. See [Manipulating an Object's Axis](#) on page 2169.

To add a surface:

- 1 In the Media list, select the media containing the front and matte that you want to add to the scene.
- 2 Do one of the following:
 - Drag the image node from the node bar and place it in the schematic. An axis and an image are created and linked together.
 - Drag the image node from the node bar to the Result view, so you can see its effect on the scene before placing it exactly where you want.
 - Double-click the image node. The node appears next to the last added object. You do not need to be in Schematic view to add a node in this manner.

By default, a Flat surface is added. You can change the surface type in the Shape box of the Surface menu. See [Changing the Shape of a Surface](#) on page 2183.

The surface is added to the scene with its own axis. The selected media in the Media list is automatically applied to the surface.

Notice that when media is applied to the image surface, the front and matte clip are combined. You can turn off the matte to show the entire front clip. See [Viewing Media](#) on page 2138.

Applying Media to Surfaces

You must select a surface before you can apply media. This lets you apply a new media to an existing surface. You cannot apply the back clip to a surface. The back clip is used as the background.

To apply media to a surface:

- 1 Select a surface by clicking one of the surface edges in the scene or changing to Schematic view and clicking the surface icon.
- 2 In the Media list, select the media to which you want to apply a surface.
- 3 Click Apply.

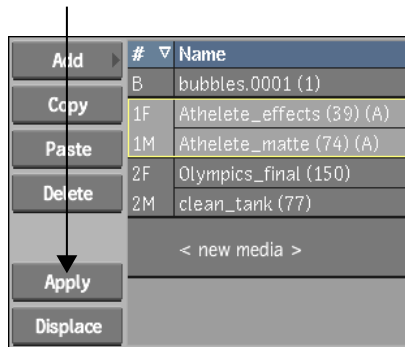

The selected surface is applied to the selected media.

Modifying Surfaces

The Surface menu includes properties common to all surfaces, and specific controls for bilinear and bicubic surfaces. You can change a surface's shape, position, and transparency, as well as apply lighting effects. You can also apply four-point tracking data to a bilinear surface.

To access the Surface menu:

- 1 Double-click the selected surface in the schematic, or follow the tab population rules for the Object menu. See [Selecting Objects and Populating Menu Tabs](#) on page 2102.

The Object Image menu appears with the Image controls for the selected surface displayed on the right side of the menu.

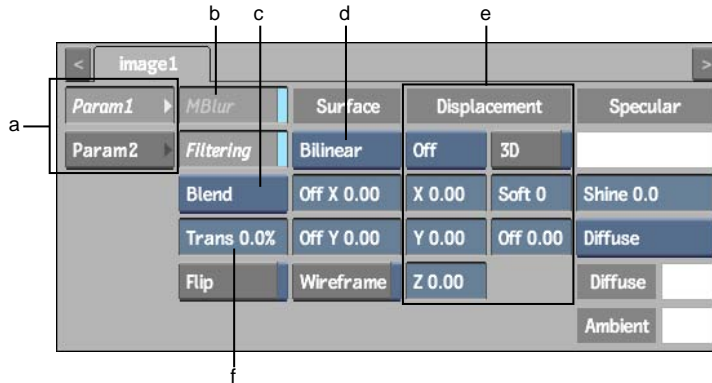

(a) Parameter tabs (b) Motion Blur button (c) Blend Mode box (d) Shape box (e) Displacement controls (f) Transparency field

The following surface controls are common to all types of surfaces.

Parameter tabs Depending on what type of surface is selected in the Shape box, there may be extra controls in the parameter tabs.

MBlur button Removes the blur for the selected surface, excluding it from the global motion blur. This option can only be used when the global motion blur is enabled.

Shape box Sets the shape of the surface. See [Changing the Shape of a Surface](#) on page 2183

Blend Mode box Sets surface blending mode. See [Surface Blending Modes](#) on page 2185.

Filtering button Enables or disables bilinear filtering. See [Filtering](#) on page 2188.

Transparency field By adjusting the transparency of the surface, you can make it fade in or out of view, or simulate a transparent material, such as glass. When the Trans field is set to 100, the surface is completely transparent. When the value is set to 0, there is no transparency in the surface.

Displacement controls Creates a 3D model using a 2D surface. See [Adding a Displacement Map](#) on page 2198.

Specular Highlight colour pot Set the highlights of a surface. Click the colour pot to select the colour of the surface highlights. See [Adjusting Specular Highlights](#) on page 2314.

Shine field Adds a shine to the specular highlights. There are no specular highlights when Shine is set to 0.

Lighting box Sets Ambient or Diffuse lighting so that the surface can reflect incidental light. See [Applying Incidental Light Reflection](#) on page 2316.

Flip button Flips the selected surface normals. This button is used to light the back side of a surface, and has no incidence on the media or the orientation of the image that is displayed by the surface.

Wireframe button Converts the selected surface to a wireframe representation. Lighting and transparency properties are kept.

Surface Offset fields Offsets a surface along the X-axis or Y-axis. See [Offsetting a Surface](#) on page 2187.

For bilinear surfaces, there are extra controls available in the Param2 tab.



(a) Offsets fields (b) Reset Selection box (c) Shape Channel button (d) Vertex Translation fields (e) Edit Offsets button (f) Stabilizer controls

Edit Offsets button and Offsets fields Edits tracker offsets. See [Editing Tracker Offsets of a Bilinear Surface](#) on page 2190.

Reset Selection box Select Reset Shape to reset the surface shape handles to their default position. The handles are reset in the current frame only. If Auto Key is enabled, a shape key is added at the current frame. Select Reset Points to reset selected points on the surface.

Shape Channel button Specifies whether you want to use the Shape channel or Surface vertex channels in the Channel Editor. See [Reshaping Using the Channel Editor](#) on page 2189.

Vertex Translation fields Verifies the coordinates of the currently selected vertex or tangent. You can modify these values to alter the shape of a surface. Press **Ctrl** and click the field to reset the selected vertex to its original position. See [Changing the Shape of a Surface](#) on page 2183.

Stabilizer controls Use to apply stabilizing data to a surface or surface offsets.

For bicubic and extended bicubic surfaces, there are extra controls available in the Param2 tab.

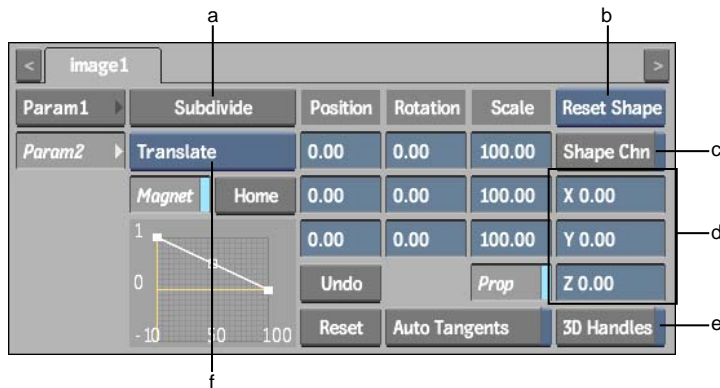

(a) Subdivide button (b) Reset Selection box (c) Shape Channel button
(d) Reference Point fields (e) 3D Handles button (f) Magnet Transformation box

Subdivide button Subdivides an extended bicubic surface into more sections. See [Subdividing an Extended Bicubic](#) on page 2192.

Position X, Y, Z fields Move selected surface points along the X,Y or Z-axis. Hold down **Ctrl** and select surface points to position them.

Rotation X, Y, Z fields Rotate selected surface points along the X,Y, or Z-axis. Hold down **Ctrl** and select surface points to rotate them.

Scale X, Y, Z fields and Prop button Scale selected surface points along the X,Y, or Z-axis. Hold down **Ctrl** and select surface points to scale them. Enable Prop to scale surface points proportionally.

Reference Point X, Y, Z fields Set the location of the reference point. Use the reference point to constrain the rotation and scaling of an individual or group of vertices.

By default, the reference point appears in the centre of the extended bicubic. When unselected, the reference point is green.

3D Handles button Enables Z buffering of the vertices. By default, the vertices are always visible, regardless of their position in Z space in relation to other media.

Auto Tangents button Scales adjacent tangents automatically. Auto Tangent creates a smooth curve between points in the deformation. If you want to work on a specific area of the image without affecting other tangents, disable Auto Tangents.

NOTE If you move a tangent explicitly, it is not affected by Auto Tangents. Click Reset Points or Reset Shape so that the tangents will be affected by the Auto Tangents mode.

Magnet button Transforms selected vertices and tangents numerically. Use in conjunction with the Magnet Transformation box. See [Transforming Multiple Points](#) on page 2193.

Magnet Transformation box Displays the type of transformation to use when Magnet is enabled.

Undo button Undoes a change to the Magnet Curve Editor.

Reset button Resets the Magnet Curve Editor.

Changing the Shape of a Surface

When you first activate media or access Action, the media's surface is set to Flat by default. In Action, you can also represent a clip using custom bilinear or bicubic surfaces.

To change the shape of a surface:

- 1 Double-click the surface in the Schematic view.

2 Select the shape of the surface from the Shape box.

Flat You cannot change its shape because a flat image does not have vertices. You can, however, scale and shear a flat image using its axis. See [Manipulating an Object's Axis](#) on page 2169.

This is the simplest surface. It is added to the scene by default the first time you enter Action with a Front, Back, and Matte.



Bilinear A bilinear surface has four vertices: one for each corner. The vertices are joined using linear interpolation (straight lines).

You can animate the shape of a bilinear surface by changing the position of the corners.

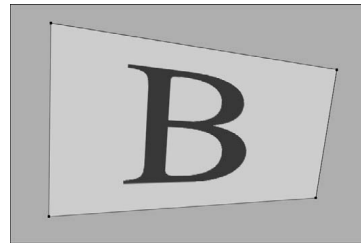

Bicubic A bicubic surface has four vertices: one for each corner. The vertices are joined using bicubic interpolation (curved lines). Each corner has two additional tangent handles used to adjust the curve of the line between points. You can animate the shape of a bicubic surface by changing the position of the corners and moving the tangent handles to adjust the curve between corners.

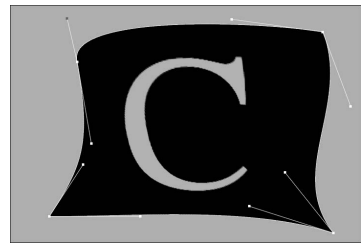

Extended Bicubic An extended bicubic surface has four vertices like a bicubic surface, but the sections of the extended bicubic surface can be subdivided to increase the number of vertices. The vertices are joined using bicubic interpolation (curved lines). You can animate the shape of a bicubic surface by changing the position of the corners and moving the tangent handles to adjust the curve between corners. See [Warping an Extended Bicubic Surface](#) on page 2190.

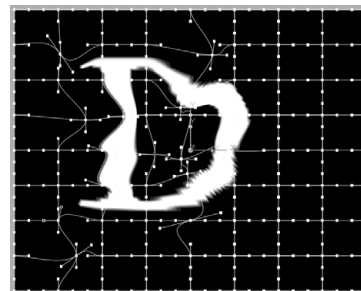

- 3 Click the vertex you want to edit and drag it to its new position.

You use the vertices—or handles—on bilinear and bicubic surfaces to change a surface's shape. You can move, rotate, shear, and scale a surface using the Axis menu. See [Accessing the Axis Menu](#) on page 2171.

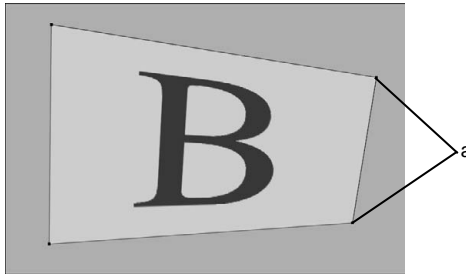

(a) Vertices on a bilinear surface

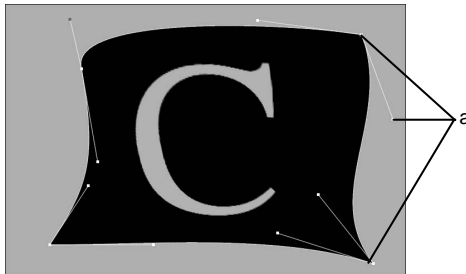

(a) Vertices and tangent handles on a bicubic surface

To move a handle on a bilinear or bicubic surface, click the handle that you want to edit. The selected handle appears in red. Use the cursor to drag the handle to its new position.

Each corner has two tangent handles. Lengthen or move the tangents to change the shape of the bicubic between corners.

All of the animation modifications you make to a shape are saved. If you decide to change a shape, then change it back to the original shape, your modifications are not lost.

Surface Blending Modes

Use the Blend Mode box to select how the front and matte clips or the front and back clips are combined. For example, use Screen for blending a fire or a

lightning bolt shot on black that you want to composite with a different background.



The surface blending modes are described as follows.

Blend Punches the matte through the front. This blends the edge of the front clip and adds additional softness to the media. This is the default setting.

Add Compensates for the soft or anti-aliased edge on an object in a front and matte clip media. This is useful for 3D images whose front is rendered over a black background.

Add Trans Add Trans mode is similar to Add but includes transparency.

Multiply Multiplies the RGB channel values of corresponding pixels of the front clip and the matte clip, and normalizes the result by dividing by 256 in 8-bit mode, or 4096 in 12-bit mode. The resulting RGB channel values are assigned to the corresponding pixels in the generated clip.

Hardware limitations may prevent transparency from working properly with Multiply.

Spotlight Creates a slide projector effect. This mode does not use the matte or transparency and decreases system performance.

Spotlight Blend Creates an effect where black areas of the front disappear. This mode does not use the matte or transparency; it works well with a clip on which an object is surrounded by black.

Simple Add Punches the matte through the front using more softness than Blend mode.

Subtract Subtracts the RGB channel values of the pixels in the matte clip from the RGB channel values of the pixels in the front clip and assigns the result to the RGB channel values of the pixel in the result.

If an RGB channel value from the matte clip is larger than the corresponding channel value in the front clip, yielding a negative result, that result is clamped at 0 (black).

Screen Multiplies the inverse of the matte clip's colours with the colours of the front clip. The resulting colour is always a lighter colour. Screen does not work with transparency.

Min Compares the RGB channels of each pixel of the front clip and the back clip individually and returns the smaller of the two values.

Max Compares the RGB channels of each pixel of the front clip and the back clip individually and returns the larger of the two values.

Negate Creates a negative-like result. Try Negate with a soft white matte with a white front clip. This mode does not use the matte or transparency in its blend.

NOTE Surface transparency varies according to the selected blend mode. You can still create a transparent surface, but you may have to access the Keyer and alter the back matte keyer curve or change the Diffuse r,g,b channels to 0,0,0. See [Accessing the Colour Corrector and the Keyer from Action](#) on page 2150.

Offsetting a Surface

By default, a surface's axis is at the centre of the surface. Use the Off X and Off Y fields to offset a surface along the X-axis or Y-axis. All rotations, scaling, and shearing applied to a surface are applied about its axis. The location of the axis is indicated by the axis icon in the scene. See [Accessing the Axis Menu](#) on page 2171.

To offset a surface:

- 1 Select the surface you want to offset.
- 2 In the Surface Param1 menu, change the Off X and Off Y fields accordingly.



(a) Surface Offset fields

The following figure illustrates the difference between rotating a surface that has not been offset and a surface offset using the Off X field.

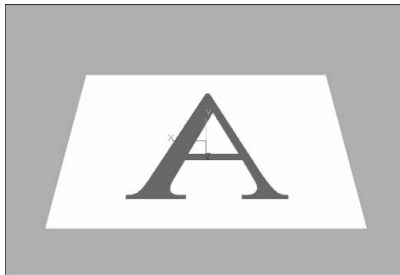

Rotated image with no offset. Notice that the axis is in the centre of the image.

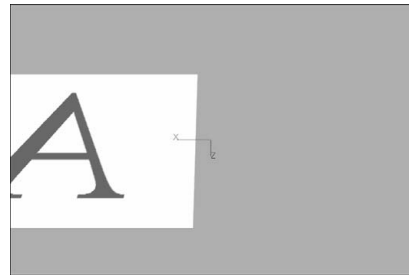

Rotated image with an offset along the X-axis. Notice that the axis is offset from the image centre.

Filtering

Use the Filtering button to enable or disable bilinear filtering of the image. If you disable Filtering and zoom in on the image, some edges may be hard. When Filtering is enabled, a smooth filter is applied to the image.

Since filtering may soften an image, sometimes you may want to turn it off if you are doing straightforward front, back, matte compositing, and if no scaling or animation is required. Turning filtering off ensures that you maintain as much of the original picture as possible. However, with filtering off, no subpixel interpolation is possible, and if you are animating the movement of an image, it may appear “steppy.”

Reshaping Using the Channel Editor

You can select whether you want to create an animation for bilinear, bicubic or extended bicubic surfaces using the Shape channel or individual Vertex channels in the Channel Editor. The Shape channel shows when the shape of the surface changes during the animation. Each time you move a surface handle, a shape key is added at the current frame, provided Auto Key is enabled in the Setup menu. See [Accessing the Channel Editor](#) on page 1964 for more information.

Vertex channels correspond to the vertices—or handles—that appear on the four corners of bilinear, bicubic, and extended bicubic surfaces. The channel names for each corner are: `upper_left`, `upper_right`, `lower_left`, and `lower_right`, and are listed in the channel hierarchy each with a position `x,y,z`.

Each corner vertex has two tangent handles—the tangent handles for `upper_left` are named `horz_tan_right` and `vert_tan_down`.

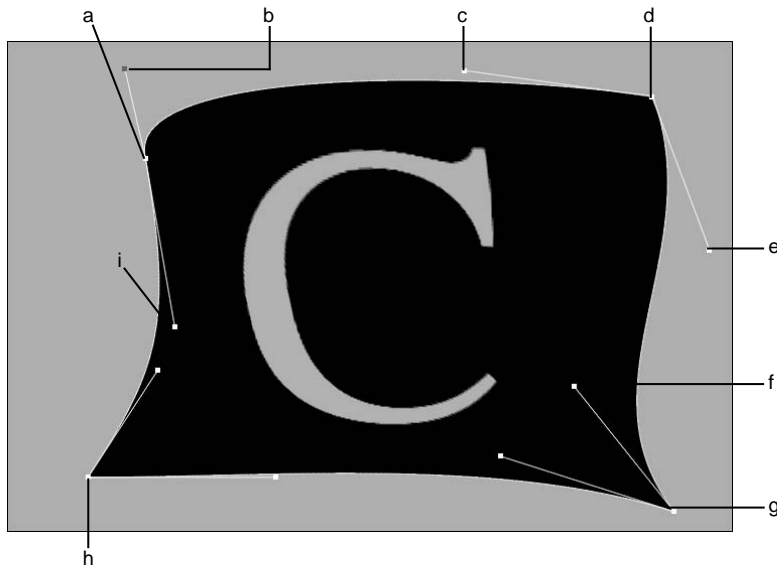

(a) `upper_left` (b) `horz_tan_right` (c) `horz_tan_left` (d) `upper_right` (e) `vert_tan_down`
(f) `vert_tan_up` (g) `lower_right` (h) `lower_left`

Extended bicubics have additional vertex channels that appear in the Channel Editor for subdivided vertex channels. These channels appear only when you create a keyframe for the channel and its value changes. These vertex channels are named `vertex_0.1`, `vertex_1.0`, `vertex_2.1`, and so on, according to their position on the surface. Click the vertex on the surface to highlight its channel

in the channel hierarchy. See [Warping an Extended Bicubic Surface](#) on page 2190.

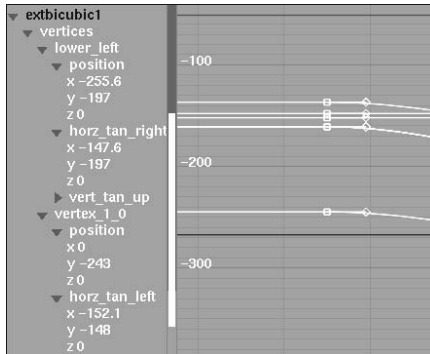

Editing Tracker Offsets of a Bilinear Surface

Enable the Edit Offsets button to change the way the image is applied to a bilinear surface. For example, when you enable this button, an offset point appears for each of the surface's four corners (if Media Front is selected in the View box), then you use the Offsets controls to edit the offsets to match the corners of your square. View the result by disabling Edit Offsets.



You can then apply stabilizing data to a surface or surface offsets. See [Four-Point Tracking](#) on page 1802.

Warping an Extended Bicubic Surface

Use an extended bicubic surface to warp specific areas of a surface. An extended bicubic surface can be subdivided into many sections, which are controlled

by vertices. The vertices allow you to bend and contort the surface. The vertices are joined using bicubic interpolation—curved lines.

You can animate the shape of a bicubic surface by changing the position of the vertices and moving the vertex tangent handles. See [Reshaping Using the Channel Editor](#) on page 2189.

By default, the extended bicubic surface has four vertices and eight tangents. You can translate, scale, or rotate these points and tangents individually or as a group. Subdividing the bicubic surface increases the number of vertices in the image and allows for more precision.

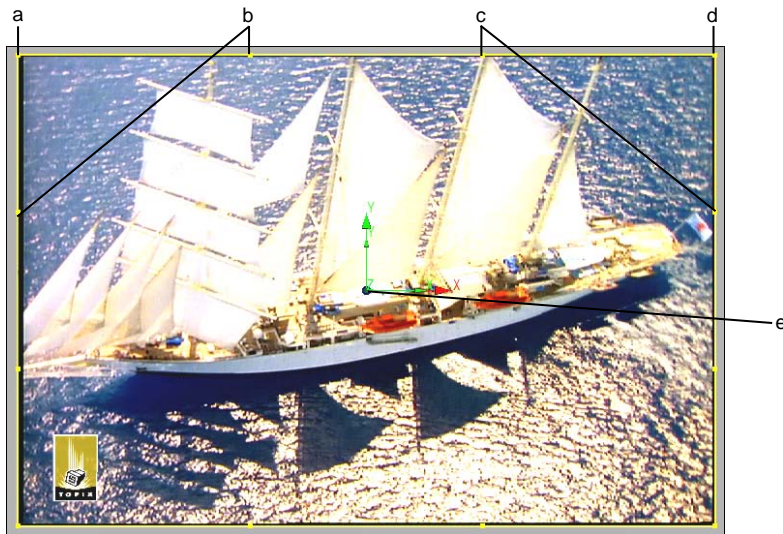

(a) vertex 1 (b) tangents of vertex 1 (c) tangents of vertex 2 (d) vertex 2 (e) Reference point

Image courtesy of Topix

Extended bicubics have three types of points: vertices, tangents, and the reference point. Vertices and tangents are collectively called *surface points*.

Vertices lie on the surface and its tangents determine the curvature of the deformation at each vertex. The reference point indicates the axis of origin for applying rotation and scaling to surface points.

Use the surface points to control the deformation of the surface. Each vertex has tangent handles. By moving the tangents and their handles, you can warp specific areas of the surface. You can translate, scale, or rotate these points and tangents individually or as a group.

Tangent handles have three modes.

This mode: Indicates:

- The handles are not broken. If you move this handle, the adjacent handle will move in the opposite direction and by the same magnitude (length).

 - The handles are broken. If you move this handle, no other handles are affected.

 - The handles are geometrically continuous. If you move this tangent, the adjacent handles will move in the opposite directions but maintain its magnitude (length).
-

Subdividing an Extended Bicubic

Subdivide the bicubic surface to increase the number of vertices and tangents. Then translate the vertices for a smaller region of the image for more precision. You should warp the surface with a small number of subdivisions to obtain the best results. After applying some deformations to a large portion of the surface, subdivide the surface further and perform deformations on a more localized region of the surface.

To subdivide extended bicubics:

- 1 From the Extended Bicubic Param2 menu, click Subdivide.

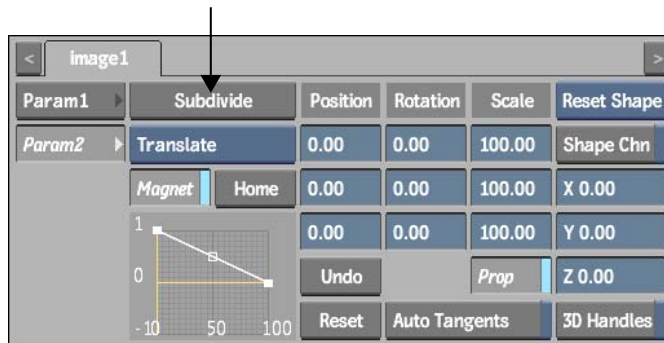

- 2 Transform the tangents to achieve the effect you want.

To move the reference point:

- 1 Select the reference point.
The reference point turns red when selected.
- 2 Drag the reference point to a new location, or use the X, Y and Z fields to assign a new coordinate for the reference point.

To rotate multiple surface points:

- 1 Set the reference point values you want to use as the axis of origin using the X, Y, Z Reference Point fields.
- 2 Select multiple surface points by pressing **Ctrl** and dragging to select the surface points.
- 3 From the Edit Mode box, select Rotate.
A 3D trackball appears on the reference point.
- 4 Use the 3D trackball to rotate the reference point and selected points.
All selected points rotate around the reference point.

To scale multiple surface points:

- 1 Set the reference point values you want to use as the axis of origin using the X, Y, Z Reference Point fields.
- 2 Select multiple surface points by pressing **Ctrl** and dragging to select the surface points.
- 3 From the Edit Mode box, select Scale.
- 4 Drag in a direction in the image window to scale accordingly.

Transforming Multiple Points

Use the magnet to transform a range of extended bicubic points. Use the magnet when there are many surface points as a result of more than one subdivision. In the Extended Bicubic menu, the magnet controls include the Magnet button, the Magnet Transformation box, and the Magnet Curve Editor.

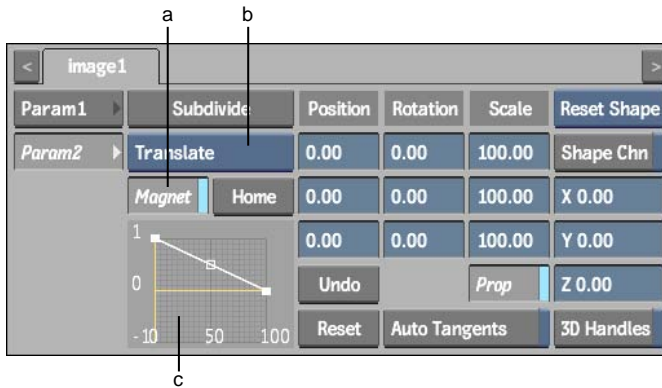

(a) Magnet button (b) Magnet Transformation box (c) Magnet Curve Editor

There are two ways to transform points with the magnet. You can use the magnet to select a range of points and transform them gesturally. Or, you can use the invisible magnet in conjunction with the Translation, Rotation, and Scale fields to transform selected points numerically.

Before you can use the magnet, you must set the polarity of the magnet and the magnet area of focus. The magnet's area of focus is determined by where you click the surface and the polarity of the magnet is set by the Magnet Curve Editor. The radius is determined by the distance from the centre to the farthest selected point.

Setting the Magnet Polarity

Use the Magnet Curve Editor to define the weighted polarity from the centre to the edge of the magnet. Points are either attracted or repelled depending on their location in the magnet and the shape of the magnet curve.

The area of the magnet is plotted on the X-axis where 0 is the centre of the magnet and 100 is the edge of the magnet. The polarity is plotted on the Y-axis where 1 is maximum positive strength and -1 is maximum negative strength.

A positive polarity value attracts nearby points. A negative polarity value repels nearby points. The following example illustrates a magnet that has a strong positive polarity near the centre and strong negative polarity near the edges.

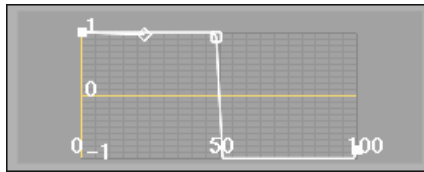

Magnetic Curve Editor

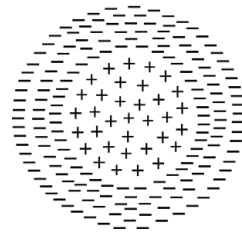

The following example illustrates a magnet that has a strong negative polarity near the centre and a strong positive polarity near the edges.

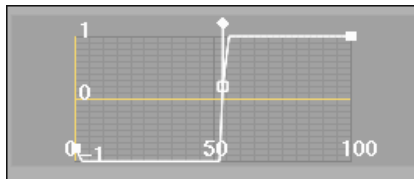

Magnetic Curve Editor

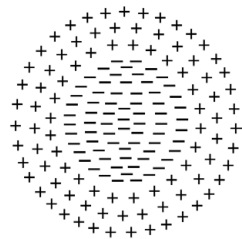

The following example illustrates a magnet whose positive polarity decreases from the centre and whose negative polarity increases toward the edges.

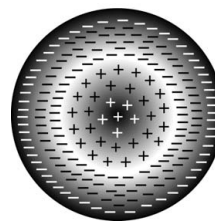
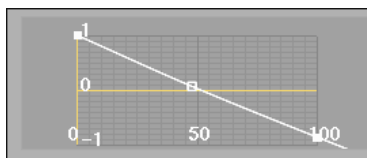

High magnet strength ——— Medium magnet Low magnet

When you transform points, the direction and size of the transformation is determined by the weighted polarity of the magnet at the location of the points.

Using the first example, if you use the magnet to translate the points on the X-axis by +200, the points in the centre of the magnet move in the positive direction on the X-axis—they are attracted to the magnet—while the points near the edge of the magnet move in the negative direction on the X axis—they are repelled by the magnet.

To change the polarity of the magnet:

- 1 In the Extended Bicubic Param2 menu, click Reset to return the magnet curve to its default.
- 2 Click the left-most handle on the curve and drag to define the polarity for the centre of the magnet.

Drag the point:**To:**

Up

Increase the positive polarity.

Down

Increase the negative polarity.

To the middle

Assign no polarity.

- 3 Click the right-most handle on the curve and drag to define the polarity for the edge of the magnet.

Drag the point:**To:**

Up

Increase the positive polarity.

Down

Increase the negative polarity.

To the middle

Assign no polarity.

- 4 Click the middle handle on the curve and drag to define the transition of polarity from the centre to the edge of the magnet.

Transforming Points

Use Magnet mode to transform points gesturally. The magnet's area of focus is determined by where you click the surface and the radius of the magnet is set by the Magnet Curve Editor. The radius is determined by the distance from the centre to the farthest selected point.

To transform points:

- 1 Use the Magnet Curve Editor to determine the polarity for the magnet. See [Setting the Magnet Polarity](#) on page 2194.
- 2 From the Edit Mode box, select Magnet.



The magnet appears as a red circular outline.

- 3 To resize the magnet, press **Ctrl+S** and drag left or right.
- 4 From the Magnet Transformation box, select the type of transformation.

Select:	To:
Translate	Translate the selected points along the X-, Y-, or Z-axis.
Rotate	Rotate the selected points about the centre of the magnet.
Scale	Scale the selected points about the centre of the magnet.

- 5 Click the points you want to transform in the image window.
- 6 Drag in the image window to apply the transformation to the selected points.

Transforming Unselectable Points

Use the invisible magnet to transform points you cannot select with the magnet. The centre of the magnet is determined by the centre of the selection and the radius is determined by the distance from the centre to the farthest selected point. Any transformations to the selected points are affected by the magnet.

To transform unselectable points:

- 1 Use the Magnet Curve Editor to determine the polarity for the magnet. See [Setting the Magnet Polarity](#) on page 2194.
- 2 From the Edit Mode box, select Move or Select.
- 3 Hold **Ctrl** and drag to select a range of points.
- 4 In the Extended Bicubic Param2 menu, enable Magnet.

The magnet is not visible, but is illustrated here to show how the points will be affected when you transform them.

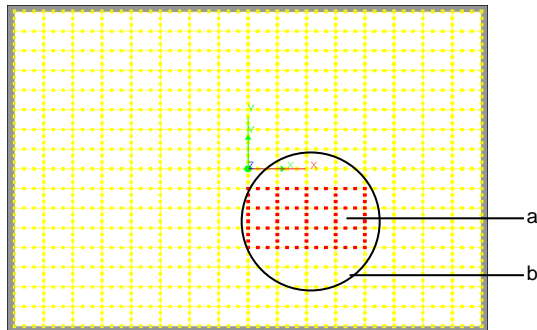

(a) Selected Points (b) Magnet (not visible)

5 From the Magnet Transformation box, select the transformation type.

Select:	To:
Translate	Translate the selected points along the X-, Y-, or Z- axis.
Rotate	Rotate the selected points about the centre of the magnet.
Scale	Scale the selected points about the centre of the magnet.

6 Change the values in the Translation, Rotation, or Scale fields.

Adding a Displacement Map

Use displacement mapping to create a 3D model from a 2D surface. The values of a selected colour channel in the displacement source clip are used to create a displacement map. When the displacement map is applied to the surface, the pixels of the surface are displaced along the positive or negative X, Y, and/or Z axes. By default, the media for the selected surface is used as the displacement source.

To set the displacement for the selected surface, use the Surface Image menu. To access the Surface Image menu, double-click the surface in the schematic, or follow the tab population rules for the Object menu (see [Selecting Objects and Populating Menu Tabs](#) on page 2102).

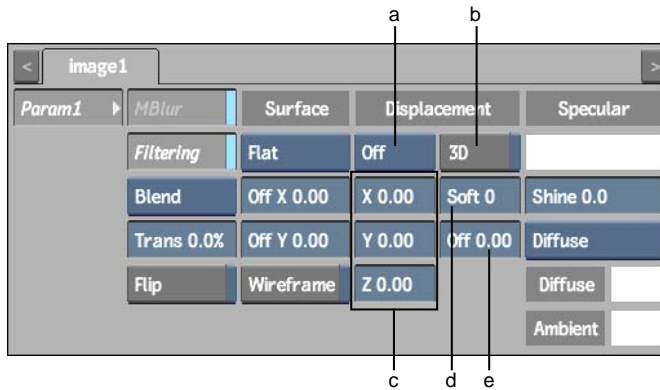

(a) Displacement Channel box (b) 3D Displacement button (c) Displacement axes
(d) Displacement Softness field (e) Offset field

The Surface Image displacement controls are described as follows.

Displacement Channel box Calculates the displacement map by selecting any of the colour channels: Use R, Use G, Use B, Use Y, Use U, or Use V.

Displacement axes Specifies the amount of displacement in pixel units along the X, Y, and Z axes. Use positive values for displacement on the positive axis, and negative values for displacement on the negative axis.

3D Displacement button Displaces bilinear and bicubic surfaces according to their normals. For image surfaces, disable 3D to displace in the X, Y, and Z directions.

Displacement Softness field Rounds off, or softens, the spikes that result from colour values in the image that vary from pixel to pixel in the displacement map.

Softness rounds the edges of the displacement. The larger the softness, the smoother the displacement. Softness also affects rendering; the larger the softness, the longer it takes to render.

Offset field Applies an offset to the displacement of X and Y.

To apply a displacement map:

- 1 In the scene or schematic, select the surface you want to displace.
- 2 In the Surface menu, select a colour channel from the Displacement Channel box. For example, select Use Y to base the displacement on the luminance of the displacement source.

- 3 In the X, Y, and Z fields, enter displacement values.
- 4 In the Displacement Softness field, set the softness of the displacement.
- 5 In the Action Setup menu, adjust the resolution in the Resolution field for a more accurate displacement.

Using a high-resolution value results in an inaccurate displacement. A low value yields good results, but takes longer to process. Typically, you compromise by specifying a high enough resolution while adding softness to make the rough edges smooth.

NOTE Displacement mapping uses the media's matte clip, so make sure that you turn the matte on or off to get the right effect.

The following figure illustrates a possible use of displacement mapping and shows the difference between displacing with and without softness.

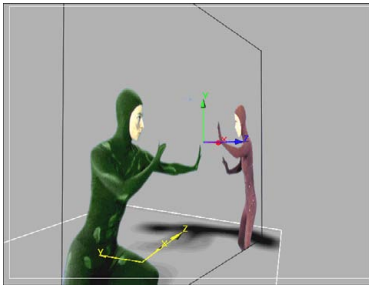

Original image

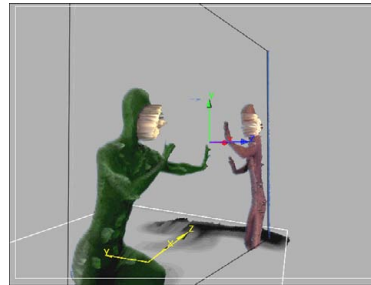

Z-axis displacement (60) using the luminance channel (Y) and a softness of 0

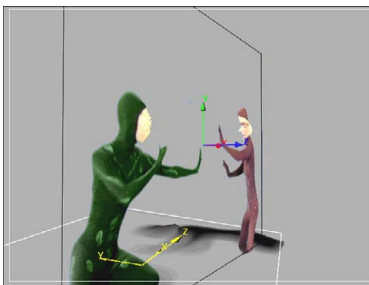

Z displacement (60) using the luminance channel (Y) and a softness of 12

Using Different Media for the Displacement Source

You can specify different media as the displacement source. Do this to apply a custom matte, or alpha, as a displacement map instead of using one media for both the texture and displacement.

NOTE If the media you select as a displacement source is not the same resolution as the destination surface, the displacement source is resized to fit the destination surface.

To use another media as the displacement source for a surface of Media1:

- 1 In Action, click Media to access the Media menu.
- 2 Select a media from the Media list, or click <new media> and Add to return to the Desktop to add new media.

NOTE If Auto Image or Auto DVE is selected in the Auto Image option box in the Setup menu, an image node and axis, or a DVE Layer Object node is created when adding new media. These nodes are not needed for displacement mapping, and can be hidden or deleted.

- 3 In the schematic, select the surface to which you want to apply displacement mapping.
Notice that in Schematic view, the number and symbol next to the name of the selected surface node is (1)(-). (1) indicates the media for the surface is Media1. (-) indicates the default media is used as the displacement source. The default media is the media applied to the surface (also Media1).
- 4 In the Media menu, click Displace.
In Schematic view, the two numbers next to the name of the selected surface node change to (1)(2), for example. (2) indicates Media2 is used as the displacement source.
- 5 To reset this override, select Node from the Reset box, click Reset, and then Confirm.

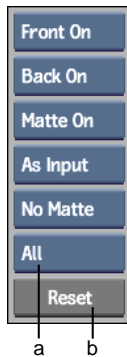

(a) Reset box (b) Reset button

NOTE Displacement mapping uses the media's matte clip, so make sure that you turn the matte on or off to get the right effect.

Adding Shadows

In Action, shadows are not cast by lit objects; shadows are cutouts based on a surface's matte. This type of shadow is referred to as a *drop shadow*. A drop shadow can be fully opaque or slightly transparent to simulate a real shadow.

To add a drop shadow:

- 1 Select the surface that you want to use.
- 2 Do one of the following:
 - Drag the shadow node from the node bar and place it in the schematic. An axis and a shadow are created and linked together.
 - Drag the shadow node from the node bar to the Result view, so you can see its effect on the scene before placing it exactly where you want.
 - Double-click the shadow node. An axis and a shadow are created and linked together. You do not need to be in Schematic view to add a node in this manner.

If a surface node is selected in the schematic, the axis of the shadow node is automatically connected to the surface.

Adjusting Shadow Softness

You can adjust the softness of a shadow using the Shadow field in the Media menu. Use a value of 0.00 to have a distinct shadow. Increase the value to soften the shadow.

Shadow softness is a property of the media. If you add more than one shadow for the same media, all shadows are softened by the same amount.

Adjusting Shadow Colour and Transparency

Adjust shadow colour and transparency in the Shadow menu of the Object menu.

To adjust the colour and transparency of a shadow:

- 1 Double-click a shadow node to display the Shadow menu.

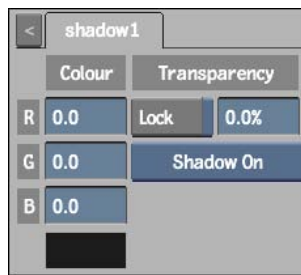

- 2 Make sure that the Shadow button is set to Shadow On.

NOTE You can turn the shadow on or off from the Shadow button. This button is independent of the Hide option.

- 3 To change the colour of the shadow, do one of the following:
 - Enter colour values in the three colour fields in the Shadow menu.
 - Click the colour pot below the fields. Use the colour picker to pick the shadow colour.
- 4 To adjust the transparency of the drop shadow, use the Transparency field. When this field is set to 100, the shadow is completely transparent. When set to 0, the shadow is completely opaque.

TIP You can lock the shadow's transparency to the transparency of its parent surface using the Transparency Lock button. Once a shadow transparency is locked to its parent surface, changes to the surface transparency also affect the shadow's transparency. You can then adjust transparency of the shadow as an offset of the surface's transparency.

Moving a Shadow

A shadow has its own parent axis. It can be moved, rotated, scaled, and sheared independently of its parent surface. Because a shadow is also the child of the surface, moving the surface axis also moves the shadow.

Using Shadow Mix

Use Shadow Mix to render shadows and surfaces according to their order in the Priority Editor, independently of their position in Z-space. This option makes it possible to have the shadow of one media on top of the shadow of another media. Shadow mix is an option in the Z-Buffer box in the Rendering section of the Setup menu.



Reordering Surfaces

When you add a surface (flat image, bilinear, or bicubic) or geometry (3D text or model), the surface or geometry appears in front of all other objects in the scene. These overlapping objects create a stack and an order of priority as one object is drawn in front of the other.

You can change the drawing order of surfaces, 3D models, and other objects using the Priority Editor.

Accessing the Priority Editor

Each entry in the Priority Editor indicates the object's name, the order of the object in the stack, and the location of the object in its branch. There is also a proxy showing what the object looks like in Schematic view.

To access the Priority Editor, swipe the bar at the bottom of the Media or Object menu.

NOTE If a source node is selected in the schematic, the Priority Editor that is displayed is that of the source node (the source node name is prepended to the branch name).

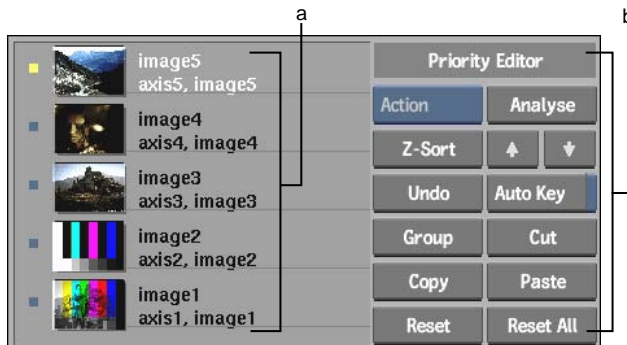

(a) Drawing order of objects in the scene (b) Priority Editor controls

Use the Priority Editor controls to analyse the scene for changes in rendering priority, to change the rendering priority, and to cut, copy, and paste priority information from one frame to another. The Priority Editor controls are described as follows.

DVE Re-entry Selection box When using DVE Layer Object re-entry, select the main scene (Action), or the Front or Matte source of your re-entered DVE Layer Object. This box is not available for objects other than DVE Layer Objects. See [Replacing a DVE Layer Object's Clip with Another](#) on page 2163.

Analyse and Z-Sort buttons Analyse the entire scene (Analyse) or the current frame (Z-Sort). A mark appears in the timebar if there is a change in drawing order. See [Analyse, Z-Sort, and the Z-Buffer](#) on page 2208.

Up and Down arrows Change the priority of the selected object. Moving media in the list will place a mark in the timebar to indicate a change in priority if Key is enabled.

The Down arrow moves the selected object one position lower in the stack, behind the next lower object. The Up arrow moves the selected object one position higher in the stack, in front of the next higher object.

Undo button Undoes the last operation. You can undo Cut, Copy, Paste, Reset, and Reset All, but *not* Z-Sort and Analyse.

Use the Undo List to view a list of recent operations and revert to a prior state. Select an item in the list to return to that state. All actions that occurred after the selected item are undone.

Auto Key button Creates keyframes when reordering media priorities. See [Creating Keyframes Using the Priority Editor](#) on page 2209.

Group button Creates groups of selected media. Use this to analyse, Z-Sort, or manage several media at once. See [Grouping Media](#) on page 2207.

Cut, Copy, and Paste buttons Cut, copy, and paste priority information between frames.

Note that a mark indicates when a change in priority occurs. If you copy and paste a mark that does not change the priority, no mark appears on the timebar.

Reset and Reset All buttons Reset priority information for the current frame or for all frames. The timebar is reset to the original priority before any changes were made.

Changing the Drawing Order

The objects in the scene are shown according to z-depth, while still being drawn in the order of their priority: highest priority at the top of the list to the lowest priority at the bottom. The lowest level object is drawn first, the second to lowest level object is drawn next, and so on, until the top of the list.

To change the drawing order of objects:

- 1 In the Priority Editor, select the object.
The selected object name is highlighted in yellow.
- 2 Click the Down arrow to move the selected object one position lower in the stack, or click the Up arrow to move the selected object one position higher in the stack.
When you move an object in the stack, a keyframe is added to the timebar.

- 3 Click Preview to ensure that the drawing order is correct.

Occasionally, a matte may obscure another object if the drawing order is unordered. If this happens, move the surface up and down in the stack until the drawing order is corrected, or click Z-Sort.

TIP You can also select and drag a media (or multiple media using **Ctrl**) while holding the **Spacebar**.

Grouping Media

Select objects in the Priority Editor and group them to edit or affect several media at once. You can analyse or Z-Sort groups as you would single media.

Groups are named according to their contents. For example, if a group is created from Image 3 and Image 32, the Group's label will be "Image 2 Image 32".

It is not possible to add a scene object to an existing group. To do this, you must ungroup the objects, reselect those you want to include in the group, and click Group.

NOTE Single element groups cannot be created.

To create groups in the Priority Editor:

- 1 Select multiple scene objects in the Priority Editor using either **Alt**-click for individual objects or **Shift**-click to select a range.
- 2 Click Group in the Priority Editor menu.

Media is minimized to a single line in the Priority Editor. To expand the group and view its contents, click the arrow to the left of the group.

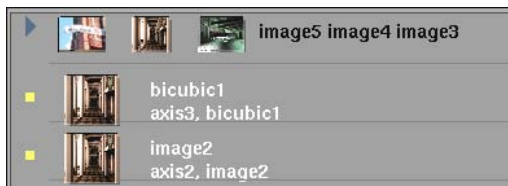

- 3 Scene objects can be ungrouped by clicking Group once again.

Analyse, Z-Sort, and the Z-Buffer

When you use Analyse or Z-Sort, the objects in the scene are compared using their position in the scene and not the individual pixels of a shape or model. The Priority Editor uses distance between the camera and the nearest and farthest points on the objects in the scene to determine the sorting order.

Since the Priority Editor is geometry based and not polygon based, you cannot properly order objects or groups that intersect due to their rotation, scale, or shear values. The Z-buffer uses the Z-value of each pixel for the sorting order. Use the Priority Editor in conjunction with the Z-Buffer box in the Setup menu Rendering section.

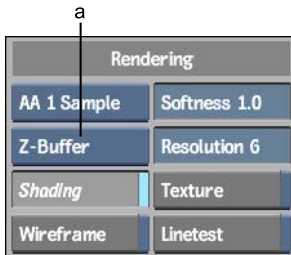

(a) Z-buffer box

When Z-buffer is on, objects and groups are arranged according to their distance from the camera eye. Since the camera is pointed towards the Z-axis by default, objects and groups are arranged according to their location on the Z-axis. In the following example, Image A is at Z position 200, Image B is at Z position 100, and Image C is at -50. When Z-buffer is on, Action draws these images as shown.

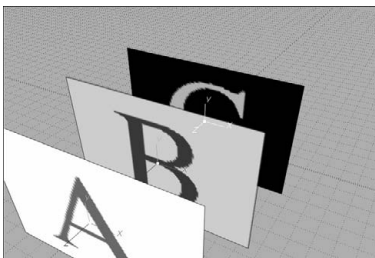

If you move the camera, objects are sorted according to the axis the camera is pointed towards.

When Z-buffer is off, the distance of objects from the camera eye is not considered. Objects are drawn in the order shown in the Priority Editor. To

follow the previous example, you can turn off Z-buffer and change the priority of Image B so that it is drawn on top of both Image A and Image C. The Z position of these images is therefore ignored.

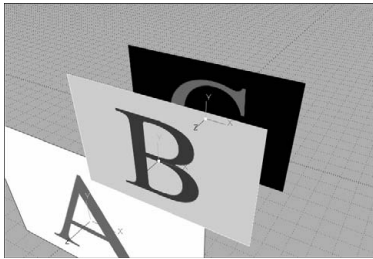

Shadow Mix, like Z-buffer, arranges objects according to their distance from the camera eye. Use Shadow Mix so that each shadow is rendered in the correct Z order with its corresponding surface.

Creating Keyframes Using the Priority Editor

When you edit media priorities in the Priority Editor, keyframes are not created by default. To create keyframes from the Priority Editor, the Auto Key button must be enabled. By default, the Auto Key button is set to off so as not to create keyframes when reordering media.

To create keyframes for a media priority change:

- 1 Display the Priority Editor by touching the swipe bar below the Media menu.
- 2 Click Auto Key to enable auto-keyframing.



- 3 Reorder priorities at different points in the timebar. Keyframes are automatically created as priorities are edited.

NOTE Stop all priority auto-keying anytime by disabling the Auto Key button.

Topics in this chapter:

- [About Source Nodes](#) on page 2211
- [Creating a Matte or Front Source](#) on page 2212
- [Replacing the Front or Matte Clip](#) on page 2215
- [Viewing a Source Node](#) on page 2217
- [Blurring with Source Nodes](#) on page 2218
- [Adding Cameras](#) on page 2219

About Source Nodes

Source nodes can be used to separate front and matte clips in media and then apply separate transformations to each clip. For example, if you apply media to a surface and you want to create an effect where the matte moves into the scene, add a source that isolates the matte clip. A matte source lets you animate the matte's position separately from the front. You can also use source nodes to apply several matte clips to a single front clip.

Use source nodes in Action to create more advanced techniques such as transforming or replacing a front or matte clip or applying motion blur.

Creating a Matte or Front Source

When you create a matte or front source, a new branch appears in the schematic showing the matte or front clip is separated from its media, ultimately replacing the matte or front with itself. This method of using source nodes lets you animate the media's matte or front separately.

To create a matte or front source:

- 1 In Action, click Media.
- 2 In the Media list, select the matte or front media that you want to replace.
- 3 Do one of the following:
 - Drag the Matte Source or Front Source node from the node bar and place it in the schematic.
 - Double-click the Matte Source or Front Source node. You do not need to be in Schematic view to add a node in this manner.
 - Drag the Matte Source or Front Source node from the node bar directly to the image window. The view switches to Source view automatically.

A source node is created in Schematic view that parents an axis and a surface.

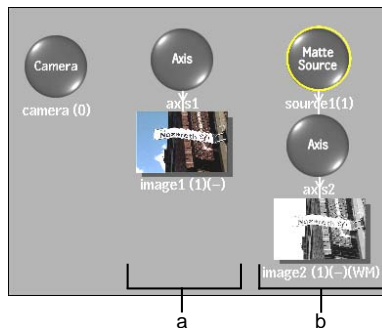

(a) Normal branch (b) Source branch

To view the contents of the source node in the image window, see [Viewing a Source Node](#) on page 2217.

NOTE You can change a source from a front to a matte source, or vice versa, from the Source Type box in the Source menu.

- 4 Select the axis or surface parented by the source and create the animation. The changes applied to the axis or surface connected to a source are applied to the media's matte or front.
For example, on a matte source, if you change the axis's scale to 80%, the media's matte is scaled 80% when used with the media's front. In addition, if you replace the surface by a bilinear or bicubic, you can create complex animations where the matte behaves like a page turn leading into the scene.

Accessing the Source Menu

Once you added source nodes to your scene, you can access the Source menu to apply various settings.

To access the Source menu:

- 1 Do one of the following:
 - Select a Matte or Front Source node in the schematic, and then click the Source menu button.

NOTE If no source node is selected when first accessing the Source menu, or if there are no source nodes present in the scene, all of the options in the menu are disabled.

- Double-click a Matte or Front Source node in the schematic.

Parenting and Redrawing Source Nodes

A source cannot be parented by other objects in the schematic. If you attempt to parent a source, the connection is refused. You can, however, parent objects inside a source node and they appear in your scene based on the Source Type settings in the Object Image menu.

NOTE Be careful when you unparent or delete a source. Surfaces or other objects that were parented by the source are added to the scene.

See [Creating Branches](#) on page 2110.

Applying Effects with Source Nodes

When applying colour corrector, blur, and crop effects with source nodes, you can apply the effects to the result of the source or to the input clip of the media.

To apply an effect to the result of the source:

- 1 In the schematic, select the source node where you want to apply an effect.
- 2 In the Source menu, enable the effects in the Post section that you want to apply to the result of the source.



You can enable any combination of colour corrector (CC), blur, and crop. For example, with a source node referring to an input clip with a blur, combined with a 3D text node, you can see the difference by enabling and disabling Blur in the Source menu.

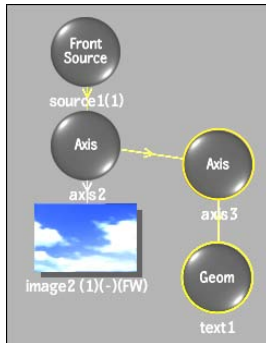

Post Blur disabled: Blur is on input clip only



Post Blur enabled: Blur is on input clip and 3D text

Replacing the Front or Matte Clip

When working with source nodes, you can replace the media's front and matte clips with the front, matte, or a combination of the front and matte clips from other media. These changes can be made in the Source menu, or in the Object Image menu of the image attached to the source node.

To replace the media's front or matte:

- 1 Double-click the source node in the schematic.
- 2 In the Source menu, change the source node from Matte to Front or vice versa.

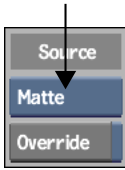

3 Enable Override.

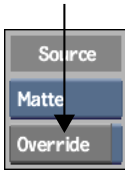

4 Select the type of source from the Source Type box.

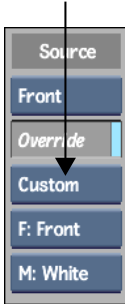

Select:	To:
Front only	Set the source to use only the front of the selected surface; the matte will be replaced with white (displayed as FW under the selected surface in the schematic).
Matte only	Set the source to use only the matte of the selected surface; the front will be replaced with white (displayed as WM under the selected surface in the schematic).
Custom	Set the source to have all the options of replacing the front and the matte of the selected surface by White, original Front or original Matte.

You can also change the source type in the Object Image menu for an image parented by a source node. The source type set in the Object Image

menu is independent of the source type set in the Source menu for the parent source node or nodes.

- 5 If you selected Custom, select the clip to use as the front and matte from the image parented by the source. You can select Front, Matte, or White for each.

For example, if you select F: Matte and M: Matte, only the matte of the source's child image is rendered and used. A summary of your choice can be seen under the image node in the schematic. In this case you will see (MM).

NOTE You can combine multiple parent sources each with their own override setting.

Viewing a Source Node

There are different ways to view a source node while working in Action. For example, a 2-up view with Schematic and Source views allows you to view the complete scene and the interactive result of your source node.

To view a source node:

- 1 From the View box, select Source (or press **F6**).



(a) View box (b) Source View box

2 From the Source View box, select which source node you want to view.

Blurring with Source Nodes

Motion blur and anti-aliasing can be set for either the front or matte clip of the media. Motion blur simulates the blur created by fast-moving objects by blurring the motion of the front or matte media.

Similar settings for anti-aliasing and motion blur can be found in the Action Setup menu. You have the option of using the same settings from the Setup menu for source nodes, or you can create specific source node settings.

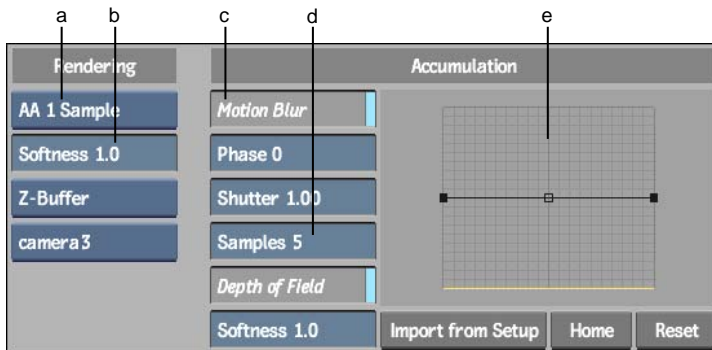

(a) Anti-Aliasing box (b) Anti-Aliasing Softness field (c) Motion Blur button (d) Samples field (e) Motion Blur Curve

The Source anti-aliasing and motion blur controls are described as follows.

Anti-Aliasing box Displays the level of anti-aliasing samples. Values of 4 and 8 give good results.

Anti-Aliasing Softness field Adjusts the degree of anti-aliasing. Use a value of 0.5 or 2.0 to get the cleanest image.

Z-Buffer button Sets the Z-buffer setting per source.

Select:	To:
Z-Buffer	Arrange sources according to their distance from the camera eye.
Z-Buffer Off	Not consider the distance from the camera eye when arranging sources.
Shadow Mix	To render each shadow in the correct Z order with its corresponding source.

Motion Blur button Applies a motion blur effect to the selected source. To create this effect, samples of previous and subsequent frames are taken and displayed over the current frame.

You set the number of samples, the transparency (weight) of the samples, and the number of frames over which the samples are taken.

Phase field Specifies whether the motion blur is based on the movement before or after the current frame. A value of -100 places the motion blur before the current frame while a value 100 places the motion blur after.

Shutter field Sets the size of the motion blur. It is essentially the number of frames that the shutter is open. Increasing this value does not increase processing time.

Samples field Determines the quality of motion blur. Increasing the number of samples improves the quality of the motion blur.

Increasing the number of samples causes the processing time to increase linearly. The number of motion blur samples is multiplied by the number of anti-aliasing samples. To reduce the total number of passes made for each frame, reduce the level of anti-aliasing when Motion Blur is enabled.

Depth of Field button Enables the camera's depth of field.

Depth of Field Softness field Defines the softness of the depth of field. A low value yields a sharp falloff between focused and unfocused regions.

Motion Blur curve Sets the weight distribution (or transparency) of the samples. Press **spacebar** and drag in the curve to pan.

Import from Setup button Uses the anti-aliasing and motion blur values from the Action Setup menu.

Home button Resets the position of the motion blur curve after panning.

Reset button Resets the anti-aliasing and motion blur settings to their default values.

Adding Cameras

You can add multiple cameras under a parent source node to change the point of view (by orbiting to a different orientation, for example). Camera 0 is always the default camera in a scene (you may need to pan in the schematic to see this camera). See [Action: Camera](#) on page 2221.

If you have multiple child cameras under a selected parent source node, you can switch from one camera to another by using the Camera Selector in the Source menu.

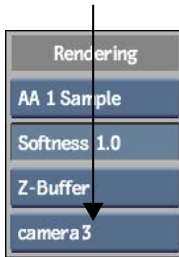

Topics in this chapter:

- [About the Camera](#) on page 2221
- [Adding a Camera](#) on page 2222
- [Working with the Frustum](#) on page 2225
- [Importing and Exporting Cameras](#) on page 2229
- [Setting Camera Views](#) on page 2233
- [Modifying the Camera](#) on page 2236
- [Applying Motion Blur](#) on page 2237
- [Applying Fog to the Scene](#) on page 2240

About the Camera

The scene is what you see through the camera lens. Typically, you work with the camera to frame and animate the view to achieve the effect you want. In Action, you have the choice of using the automatic camera or the manual camera, whose F-Stop, film size, and focal length you can set yourself. You can also animate specific camera properties.

Adding a Camera

By default, a camera exists in the Action scene (you may need to pan in the schematic to see the camera node). You can add multiple cameras in order to change point of view or depth of field from one camera to another. Add and animate multiple cameras when creating compositions. You can also switch from one camera to another at any point.

To add a camera:

- 1 Do one of the following:
 - Drag the camera node from the node bar and place it in the schematic.
 - Drag the camera node from the node bar to Result view, so you can see its effect on the scene before placing it exactly where you want.
 - Double-click the camera node. The node appears next to the last added object. You do not need to be in Schematic view to add a node in this manner.

A new camera is added to the scene. An icon representing the camera is added to the schematic.

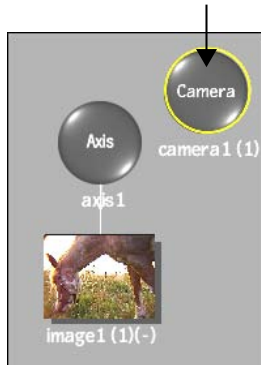

- 2 To display the Camera menu, double-click the selected camera in the schematic, or follow the tab population rules for the Object menu. See [Selecting Objects and Populating Menu Tabs](#) on page 2102.
The result camera always appears as the first tab on the right side of the Object menu. To allow you to easily access the camera without losing your place in the scene, this special camera tab (appearing in orange) does not follow the tab population rules. If a camera node is selected in

the schematic, the special Camera tab does not appear, and the normal tab population rules apply.



The Camera controls are described as follows.

Camera Eye X, Y, and Z fields Specify the position of the camera eye on the horizontal, vertical, and perpendicular (X, Y, and Z) axes.

Motion Path button Animates the camera eye on a motion path. See [Moving the Camera Eye and Point of Interest](#) on page 2227.

Camera point of interest X, Y, and Z fields Specify the position of the point of interest on the horizontal, vertical, and perpendicular (X, Y, and Z) axes.

Camera Rotation X, Y, and Z fields Rotate the camera on the horizontal, vertical, and perpendicular (X, Y, and Z) axes.

Camera Type box Provides Free and Target Camera options.

Free Camera views the scene in the direction that you aim the camera. Free cameras are easy to use because you do not have to manipulate the point of interest. You can simply animate the camera rotation or camera tilt as though it were on a tripod. Use the Distance field in conjunction with Free Camera.

Target Camera ensures the camera is specifically aimed at a target object in the scene because you specify the point of interest. Use the Roll field in conjunction with Target Camera.

Roll field Sets the amount of camera roll. This field is available with the Target Camera.

Field of View field Specifies the camera field of view, measured in degrees.

When PhysicalCam is disabled, use the field of view angle in the Y direction to adjust the width of the camera frustum. When PhysicalCam is enabled, use the focal length for the same purpose.

Distance field Specifies where the camera's focus is. This parameter affects the depth of field (when enabled in the Action Setup menu).

Near and Far fields Specify the position of the near and far clipping planes. See [Moving the Clipping Planes](#) on page 2227.

Export Camera button Exports camera path information from Action to 3ds Max format.

Exported data includes Eye X, Y, and Z; Poi X, Y, and Z; Fov; Roll, Target or Free Camera; motion path and explicit keyframe camera animation. See [Importing and Exporting Cameras](#) on page 2229.

Import Camera button Imports 3ds Max camera path information. Select the camera path file that contains the data you want. See [Importing and Exporting Cameras](#) on page 2229.

Result Camera box Specify which camera is active. The active camera is the one that will be used when processing/rendering your scene. The field displays the active camera number. A value of 0 indicates that you are viewing the scene through the default camera.

Reset Camera button Resets the Camera menu to its default settings.

Physical Camera and Fog options are located in the Camera Param2 tab.

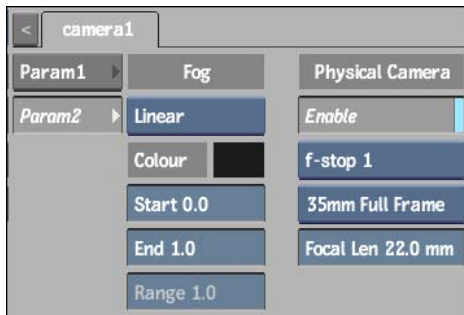

Fog box Select the fog type to use. See [Applying Fog to the Scene](#) on page 2240.

Fog colour pot Use the colour pot to select the fog colour.

Start field Specify the distance at which Linear type fog should start.

End field Specify the distance at which Linear type fog should end.

Range field Specify the range or distance from the camera for Exponential type fog.

Enable button Activates the physical camera, which simulates a manual camera. Use the physical camera fields to adjust the field of view for the camera.

F-Stop box Adjusts the depth of field. F-stop is the ratio between the focal length of the lens and the diameter of the aperture. For example, the F-stop value for a 100mm lens with a 50mm full aperture is 2 (or $f/2$).

Large F-stop values correspond to smaller apertures. The depth of field for your physical camera increases as you increase the F-stop value. In Action, you can select standard F-stops.

Film Size box Displays the standard film size. As the film size increases, the focal length also increases and the focal point moves further away from the camera eye. Changing the film size also increases the focal length.

Focal Length field Adjusts the field of view. Changes you make to the Focal Length automatically update the field of view (based on the film size) and vice versa.

As the focal length increases, the field of view decreases. As the focal length decreases, the field of view increases.

Working with the Frustum

The volume of space viewed by the camera eye is called the frustum. The frustum is in effect a viewing pyramid. The camera eye is located at the apex of the pyramid, and the far clipping plane forms the base. The pyramid may be truncated by the near clipping plane.

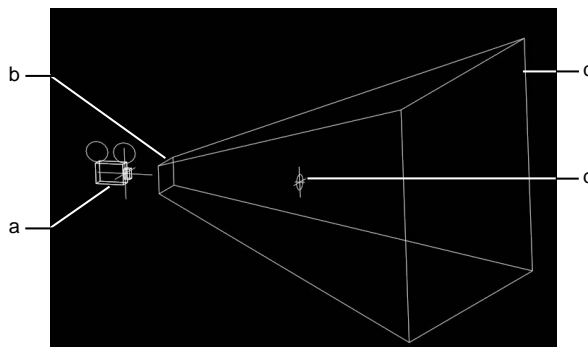

(a) Camera eye (b) Near clipping plane (c) Far clipping plane (d) Camera interest point or look-at point

If you place a surface within the frustum, it is visible in the final animation. If the surface is located outside the scope of the frustum, it is not visible at that frame in the animation.

To see the camera and frustum:

- 1 From the View box, select Side.



- 2 In the image window controls, click  to zoom out from the scene.
- 3 Select Pan in the Edit Mode box and pan around the scene until you see the camera eye icon. Alternatively, use Orbit mode to pan around the scene in circular motion.
- 4 Go to the Camera menu and drag the Roll field until you see the four sides of the frustum.
- 5 To modify the frustum, do one of the following:
 - Change the position of the near clipping planes to alter the depth of the frustum. See [Moving the Clipping Planes](#) on page 2227.
 - Change the position of either the camera eye or the camera's point of interest to alter the orientation of the frustum. See [Moving the Camera Eye and Point of Interest](#) on page 2227.
 - If the Physical Camera button is disabled, enter a value in the FOV (field of view) field to adjust the width of the camera frustum.

- If the Physical Cam button is enabled, enter a value in the Focal Length field to narrow or widen the frustum. You can also alter the depth of the frustum using only the near clipping plane.

Moving the Clipping Planes

The camera frustum is determined by six clipping planes: the left, right, top, bottom, near, and far clipping planes. The depth of the frustum is affected by the near and far clipping planes. The values for these channels are expressed in units relative to the position of the camera eye.

To move the clipping planes:

- 1 From the View box, select Side, Front or Top depending on how your camera is positioned. Ideally, you will want a view that profiles the camera so the near and far planes are visible.
- 2 In the Camera menu, enter a value in the Near field to edit the near clipping plane's position.
The value in the Near field corresponds to the position of the near clipping plane. The default value is 1. Any object between the camera eye and the near clipping plane is outside the camera frustum and does not get processed in the final result.
- 3 Enter a value in the Far field to edit the far clipping plane's position.
The value in the Far field corresponds to the position of the far clipping plane. The default value is 10000. Any object positioned behind the far clipping plane is outside the camera frustum and does not get processed in the final result.
- 4 Narrow or widen the frustum by modifying the camera's FOV (field of view). Increasing the FOV narrows the frustum and field of view. Decreasing the value widens the frustum and field of view.

Moving the Camera Eye and Point of Interest

Objects in the scene can be recorded from an arbitrary position as determined by the orientation of the camera eye in world space.

To change the position of the camera eye:

- 1 In the Camera menu, modify the Eye X, Y, and Z fields.

You can also animate the camera eye on a motion path. Enable the Motion Path button and drag the camera icon while viewing the scene in Top, Side, or Front view.

NOTE You can only animate the point of interest with a Target Camera.

The camera point of interest is the point in world space at which the camera eye is directed. The point of interest is always at the centre of the camera's frustum. Changing the position of the point of interest causes the orientation of the frustum to change. You can take advantage of the relationship between the point of interest and the frustum to make the camera follow a moving object. To do this, animate the point of interest while keeping the camera eye in a fixed position.

To change the point of interest:

- 1 In the Camera menu, do one of the following:
 - Modify the Interest X, Y, and Z fields.
 - Move the point of interest by dragging while viewing the scene in Top, Side, or Front view.

TIP You can animate the point of interest using a motion path by enabling the Motion Path button.

Adjusting the Depth of Field

Using depth of field, you can blur objects that are outside the camera's focal range. The further an object is from the focal range, the more it is blurred.

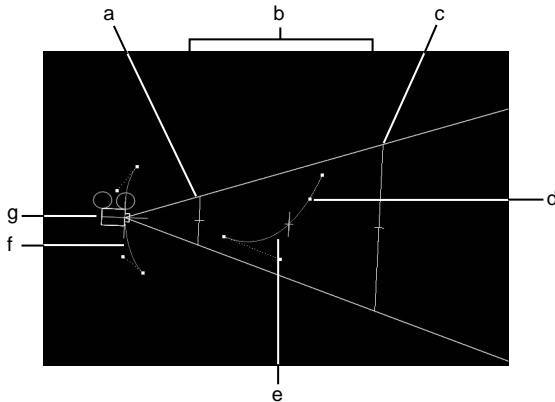

(a) Near sharpness plane (b) Focal range (c) Far sharpness plane (d) Motion path for point of interest (e) Camera point of interest (f) Motion path for camera eye (g) Camera eye

The Target camera uses depth of field and clearly indicates its focal range when in Top, Side, or Front view. With the Free camera, you can change the field of view by **Alt**-dragging the near sharpness plane. This changes the camera only; what you are viewing remains the same size.

To adjust the depth of field:

- 1 In the Action menu, click Setup.
- 2 In the Accumulation Settings section, enable Depth of Field. Objects are blurred on either side of the point of interest.
- 3 Change the amount of blur using the Depth of Field Softness field.

Importing and Exporting Cameras

You can either import a camera you created and edited in Action, or import one from another 3D application. Once a camera is imported, you can edit its parameters, change its animation, and then export it back to the application it came from.

FBX Cameras

Flame supports the import and export of 3D data saved in the Alias® FBX 3D format. The FBX standard format provides a means for exchanging 3D data

for scene compositions—such as cameras—between tools and packages developed by different manufacturers.

FBX support makes the import and export of 3ds Max, Alias Wavefront™|Maya®, Softimage® |XSI™, and LightWave 3D® formats possible. For information on how to import an FBX format camera, see [Importing the FBX Format](#) on page 2277.

To export a camera to FBX format:

- 1 Select the camera you want to export.
- 2 In the Camera menu, click Export.



The Export Camera file browser appears.

- 3 From the Export Type box, select FBX.

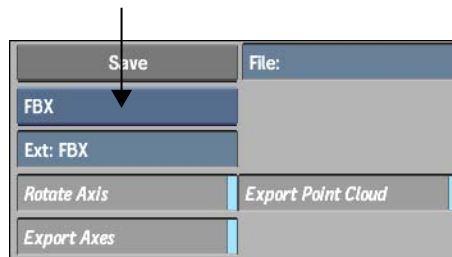

- 4 Select which elements of the FBX files you wish to export by clicking the corresponding filter button.

Enable:	To:
Rotate Axis	Rotate the exported camera by -90° on the X-axis so that it is compatible with the coordinate system of the 3D application.

Enable:	To:
Export Axes	Export the animated axes present in the Action scene.
Export Point Cloud	Export the 3D point cloud created by the 3D Tracker.

- 5 Navigate to the location where you want to export the camera animation.
- 6 Enter a name for your exported camera in the file field.
- 7 Click Save.

3ds Max Cameras

An alternative to animating a camera's position is to import a camera animation from 3ds Max. 3ds Max camera animation can be saved as a .3DS or .ase (ASCII Scene Export) file in your scene. While the .ase format contains only a camera's positional data, the .3DS format contains the camera's position, point of interest, roll and field of view values.

Once the camera is imported, you can edit any of the camera's values and, if necessary, export it back to 3ds Max in its native 3DS format using the Camera menu.

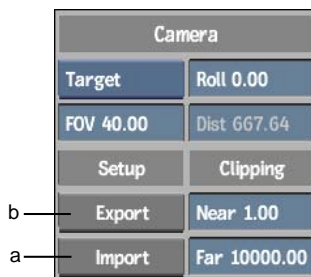

(a) Import Camera button (b) Export Camera button

To import a 3ds Max camera:

- 1 In the Camera menu, click Import.
The Import Camera file browser appears.
- 2 From the Import Type box, select either the .3DS or .ase format.

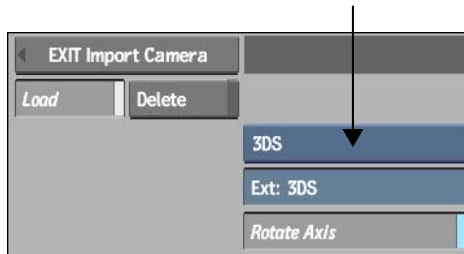

- 3 If needed, enable Rotate Axis to rotate the imported camera by 90° on the X-axis so that it is compatible with Action's coordinate system.
- 4 Navigate to the location where a 3ds Max camera setup was exported, and select the file.
You return to Action and the imported camera is applied to your scene.

To export a camera to 3ds Max format:

- 1 Select the camera you want to export.
- 2 In the Camera menu, click Export.



The Export Camera file browser appears.

- 3 From the Export Type box, select 3DS.

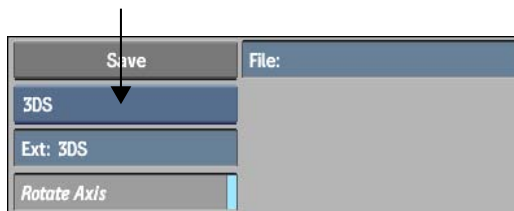

- 4 If needed, enable Rotate Axis to rotate the exported camera by -90° on the X-axis so that it is compatible with the coordinate system of the 3D application.
- 5 Navigate to the location where you want to export the camera animation.
- 6 Enter a name for your exported camera in the file field.
- 7 Click Save.

NOTE When exporting from Flame, save the .3DS file in a directory that is readable by a 3ds Max system.

Setting Camera Views

You can view the scene from various angles and display multiple views of these angles simultaneously. This is helpful in setting motion paths, light sources, camera angles, and animation keyframes more accurately.

Camera and Orthographic Views

You can view the scene from Camera view and three orthographic views. In Camera view, an object becomes smaller as it moves farther away from the camera. In orthographic view, an object remains the same size, regardless of its distance from the camera. Orthographic views are more helpful for aligning objects.

The following figures illustrate the different angles by which the scene can be viewed. The scene in this example contains a grey back clip and the 3D model of an apple.

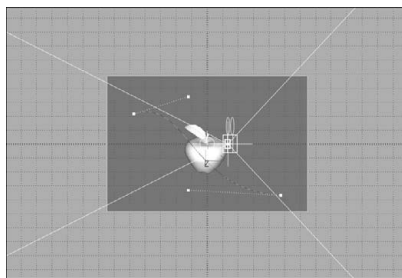

Front view

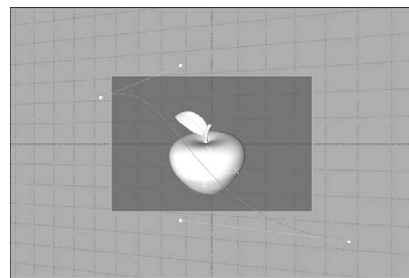

Camera view

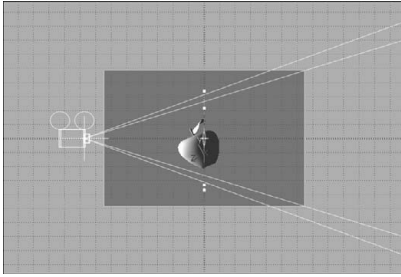

Side view

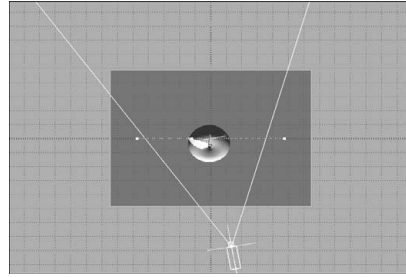

Top view

To set camera and orthographic views:

- 1 From the View box, select Camera or an orthographic view. When in Camera view, use the Camera box that appears to select which camera is used in the image window.

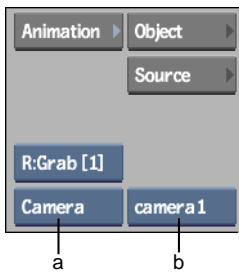

(a) View box (b) Camera box

Select:	To:
Camera	View the scene in Camera view. This is the scene as viewed by the camera eye. In other words, your field of vision in world space is equivalent to the viewing frustum of the camera. The size of objects depends on their distance from the camera eye.
Top	View the scene as if you are positioned on the positive Y-axis. This is an orthographic view; there is no perspective deformation.
Side	View the scene from the side, as if you are positioned on the positive X-axis. This is an orthographic view; there is no perspective deformation.

Select: **To:**

Front View the scene as if your line of vision is directed into the camera eye. This is an orthographic view; there is no perspective deformation.

2 If you have multiple cameras in the scene, use the Camera box to define which camera is used for the Camera view in the image window. The camera selected in this box is not necessarily the camera used to process the scene.

3 Adjust the view with the Ortho Views controls, if needed.

When using an orthographic view, you may notice that parts of the object you are viewing are getting cut off. Adjust the near and far ortho views. You gain more space to view the object, but lose some viewing precision.

In the Display section of the Action Setup menu , adjust the Near and Far fields.

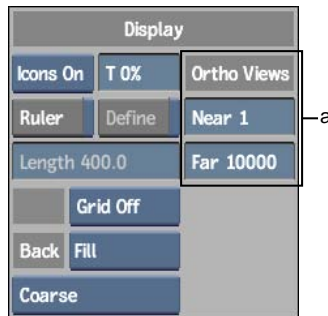

(a) Ortho Views in Setup menu

NOTE The Ortho Views parameters in the Action Setup menu are only for viewing objects, and cannot be animated or saved. The Near and Far fields in the Camera menu are used to set clipping planes. See [Moving the Clipping Planes](#) on page 2227.

In addition to Camera and the three orthographic views, you can also select Schematic view, which uses nodes to represent the objects in the scene and arrows to illustrate the relationships between objects. See [Reshaping Using the Channel Editor](#) on page 2189.

Modifying the Camera

You can gesturally modify the camera directly in the scene using options in the Edit Mode box. A mode remains in effect until you select a different mode.

To gesturally modify the camera:

- 1 Make a selection in the Edit Mode box.

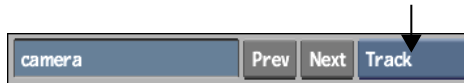

Select:	To:
Track	Move the camera lens and look-at point.
Tilt	Tilt the camera up and down by moving the look-at point. Also changes the camera roll. This option only modifies Target cameras.
Roll	Rotate the camera on the Z-axis. This option only modifies Target cameras.
Orbit	Rotate the camera lens around the look-at point.
FOV	Move the camera field of view.
Dolly	Move the camera lens towards (zoom in) or away from (zoom out) the look-at point.
Pan	Move the camera left and right by moving the look-at point. Also changes the camera roll, when not 0.00.

- 2 Drag the cursor in the image window.

The camera is modified. Related Camera menu controls are updated to reflect the changes.

Zooming In and Out

Use the Zoom option to move the camera eye toward or away from the point of interest. While viewing the scene in Camera view, zoom in or out from the point of interest to move the camera eye closer to or farther from the point of interest. In Top, Side, or Front view, you can enlarge or reduce the scene

in the image window without affecting the camera. Zooming has no effect in Schematic view.

To zoom the camera:

- 1 From the Edit Mode box, select Zoom.
- 2 Place the cursor in the image window.
The cursor changes to a magnifying glass.
- 3 To zoom in, drag the cursor to the left. To zoom out, drag the cursor to the right.

Applying Motion Blur

Use the Motion Blur tool to simulate the blur created by fast-moving objects. Motion Blur is used with both the normal and physical cameras. You can apply motion blur globally (to the entire scene) and then exclude objects in the scene from its effect.

To use motion blur, enable the Motion Blur button in the Action Setup menu and specify motion blur settings. See [Accumulation Settings](#) on page 2120.

Blurring a Single Object

You can apply motion blur to an object rather than to the entire scene. To use the per object motion blur, you must apply Motion Blur globally, and then disable motion blur per object.

NOTE The motion blur curve in the Action Setup menu is global. It cannot be set per node. When motion blur is enabled, all surfaces have the same blur characteristics but not necessarily the same animation.

To blur a single object:

- 1 Enable Motion Blur in the Action Setup menu.
This activates a global motion blur applied to everything within the scene.
- 2 You can then disable motion blur per object in the surface, axis or light menus to exclude objects from the global motion blur.

Creating Custom Motion Blurs

The motion blur curve controls the sample weight over the scope of the motion blur. The point on the left is the weight of the first sample and the point on the right is the weight of the last sample. By changing the curve, you can create custom motion blur effects such as a Gaussian blur.

As with the Channel Editor, you can add keyframes to the motion blur curve using Add mode, move keyframes with Move mode, and modify the curve's shape using tangent handles.

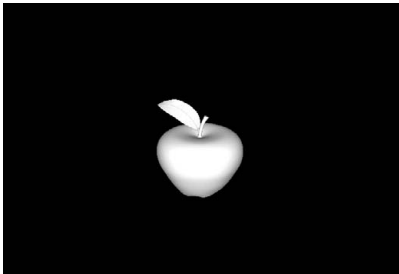

The original animation with Motion Blur disabled.

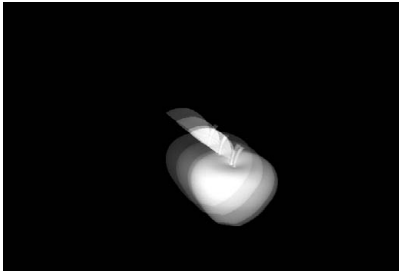

Motion Blur is enabled using a custom motion blur curve and phase set to 100.

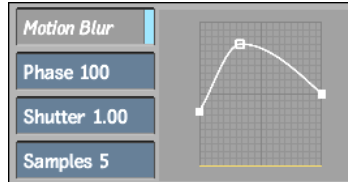

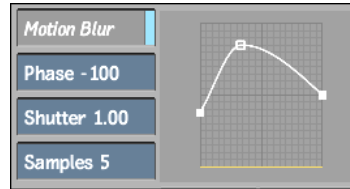
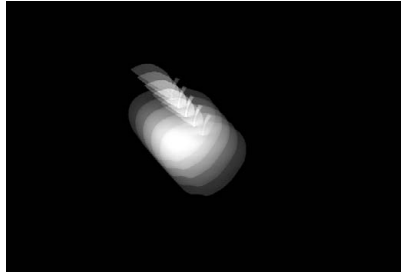

Motion Blur is enabled using the same motion blur curve as above. Phase is set to -100.

TIP You can preview your motion blur effect in Batch or Action by clicking Preview. This will display the rendered frame at the current frame in the timebar. Should you want to see the whole sequence, attach a node to the Batch output and show the node's front clip while jogging the timebar positioner.

Simulating Motion Blur on a Still Object

You can add motion blur to an object that has no axis movement, by adding a second axis to simulate the motion.

To simulate motion blur on a still object:

- 1 From the View box, select Schematic.
- 2 From the Node bin, drag an Axis node to the schematic.
- 3 Press **Shift** and drag the original Axis node over the new Axis node.

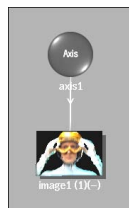

Still object with Axis

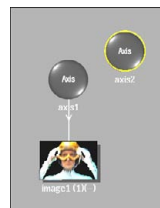

New axis added

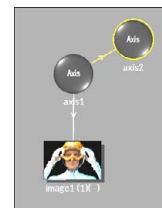

New axis as child of original axis

Image courtesy of Das Werk

- 4 Enable Motion Blur and animate the new axis with the desired motion.

Applying Fog to the Scene

Use fog in the scene to create visual effects such as mist, haze, and murky water. The fog effect causes objects to fade as their distance from the camera increases. The further an object is from the camera, the foggier the scene appears.

The fog effect is based on depth-cueing, which means the intensity of the fog varies along the Z-axis, and the specified colour gradually increases or decreases its intensity.

You control the density and colour of the fog using the fog controls in the Camera menu.

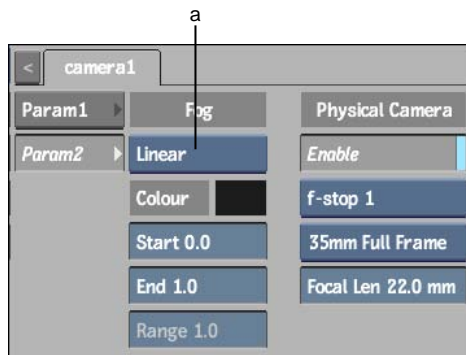

(a) Fog box

Try combining your fog effect with other effects such as transparency to create a more genuine look for non-solid substances such as water. You can also use expressions to improve the quality of fog in a scene so that it looks more natural. See [Working with Expressions in the Channel Editor](#) on page 2043.

To add fog to the scene:

- 1 In the Camera menu, select a fog type from the Fog box.

Type	Description
Linear	Specifies the distance at which fog should start and end.

Type	Description
Exponential	Fog = $e^{-(\text{density} * z)}$ where z represents the range or distance from the camera. The range should lie within the realm of the near and far clipping planes. The minimum value is 1.
Exponential2	Fog = $e^{-(\text{density} * z)^2}$. The exponential types provide more depth, more natural looking fog, and make the edges appear smoother.

- 2 For Linear fog, specify the distance at which the fog should start and end in the Start and End fields. For Exp or Exp2 fog, specify the range in the Range field.
- 3 To select the colour of the fog, click the colour pot to display the colour picker.
Typically, the fog colour should match the background colour of the image in the scene.

Action: 3D Camera Tracking

76

Topics in this chapter:

- [About 3D Camera Tracking](#) on page 2243
- [Accessing the 3D Tracker](#) on page 2243
- [Preparing to Track](#) on page 2244
- [Auto 3D Tracking](#) on page 2245
- [Manual 3D Tracking](#) on page 2254

About 3D Camera Tracking

Use Action's 3D tracker to compute the path of live-action camera motion in 3D space. Using the calculated position and motion of the virtual camera, you can match image sequences perfectly, placing any element in the scene. The perspective of the element you place in the scene changes with the perspective of the background as the camera moves. The virtual camera motion is intended to be identical to the motion of the actual camera that shot the scene.

Accessing the 3D Tracker

The 3D tracker is accessed through Action's Camera menu.

To access the 3D tracker:

- 1 In Action, click 3D Track.



The 3D tracking controls appear.

- 2 From the 3D Tracker Option box, select the Auto or Manual tracker.

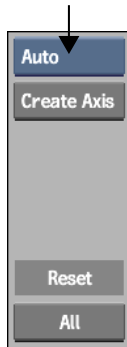

Preparing to Track

A good 3D tracking result is often footage dependant, therefore you may decide to use the auto or manual 3D tracker. In most cases, the auto 3D tracker gives good results. In some instances, such as when the motion is confined to the axes, and there is little or no perspective rotation, the manual tracker may be a better choice.

Here are some things to keep in mind that can improve your 3D track:

- The 3D tracker works best when tracking an image sequence that has a moving camera or environment. Objects or actors that are moving in an image sequence can cause bad results. You should mask these objects so

that they are ignored in the tracking process. You should also mask any logos or watermarks in your image sequence.

- The 3D tracker analysis is based on point-like and corner-like image features. Balls, spheres, lines, and smooth surfaces are not considered.
- Crop out any black areas around your image (such as letterbox areas). When cropping, it is very important to keep the optical centre of the image in the centre, that is, the crop should be symmetrical in both dimensions.
- To be able to convert the tracking results correctly, the resolution and aspect ratio of the image being analysed must match the resolution and aspect ratio set in the Action Setup menu.
- 3D tracking analyses each frame extensively and with high resolution clips, the process can be lengthy. Unlike 2D tracking, however, you are not required to analyse full-resolution clips. In many cases, analysing proxies will produce acceptable 3D tracking results, in a fraction of the time that would be required for the full-resolution clips.
- If you have information about the camera that shot the scene you want to track, such as the focal length of the lens and the film back size, you can specify these details to help the 3D tracking analysis.

Auto 3D Tracking

The first step in 3D auto tracking is to perform your initial tracking. Depending on the result, you can also fine-tune the track.

To create a 3D auto track:

- 1 From the 3D Tracker option box, select Auto.
- 2 In the Track Media field, specify the media number of the front clip you want to track. A value of 0 indicates that the Back clip is tracked.

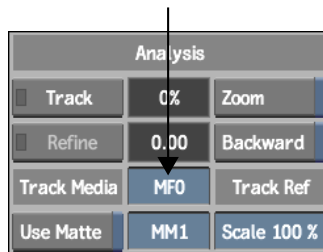

- 3 Enable Use Matte and specify the Matte media if you want to use a matte to delimit the tracking results. For example, in an image sequence of a busy street, you can create a matte of moving elements (such as cars and people) to isolate this area from the analysis.

White areas of the matte are considered for calculating the solution; black areas are ignored (unless you selected Matte Invert from the Matte Clip box).

NOTE Use a matte made from real frames. Keyer or Gmask outputs do not work as a matte for 3D tracking.

- 4 If needed, set Camera and Film Back options. See [Setting Camera Properties for 3D Auto Tracking](#) on page 2248.
- 5 If needed, select Analysis options.

Enable:	To:
Zoom	Calculate the zoom value of the reconstructed camera for each frame (assuming the camera that shot the tracked clip has a variable zoom value). By default, Zoom is disabled (that is, the track analyses with a fixed zoom).
Backward	Track the image sequence backward after the forward tracking has completed. This option takes longer, but you may get better results.

- 6 If needed, adjust the scale of the trackers.
Smaller trackers can speed up the calculation, while larger trackers make the analysis more robust with regard to image noise and variations. A general rule is to increase the scale of the trackers when tracking high-resolution footage (2K or larger) that contains more noise or less sharpness.
- 7 From the Icons section, select tracker display options.

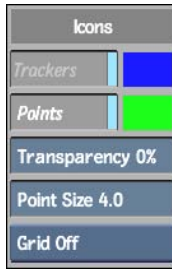

Enable:	To display:
Trackers	2D tracks. Use the colour pot to select the colour of the tracks.
Points	3D points. Use the colour pot to select the colour of the points. The points option is also available in the Display section of the Setup menu (or with the hot key Alt+D), so that you can enable the display of 3D points while you are working in other Action menus. 3D points are viewable in 3D in all Camera views in Action (Side, Front, Top, or Camera) to help you position objects in the reconstructed scene.

You can also adjust the transparency of the trackers and points and the size of the points in your image.

Use the Grid box to display a grid so that you can position objects in the scene more accurately. The same Grid box is available in the Display section of the Setup menu.

- Click Track. Tracking occurs in the background, allowing you to continue working while tracking.

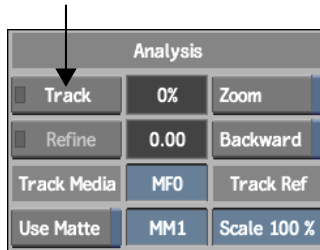

You can see a progress indicator beside the Track button. You can interrupt the analysis and resume it by clicking Track again. After tracking has completed and you press Confirm, the Track button changes to Calibrate, and you can see the 2D tracks (the blue squares in the following example) and 3D points (green crosses) in your image, if you chose to display them.

A camera called *Camera_3dt_sync* is also generated when an analysis is performed. This camera synchronizes to the results of your auto 3D tracking, and any further changes you make to the 3D track are reflected in this camera.

NOTE If you reset the 3D tracker settings, the synchronized camera becomes a regular Action camera.



Image courtesy of Behavior Communications Inc.

- 9 If you are satisfied with the results of the tracking analysis, proceed to [Defining the Auto Track Ground Plane](#) on page 2252 and [Converting the 3D Auto Tracking Results](#) on page 2253. If you want to tweak your track results, see [Fine-tuning the 3D Auto Track](#) on page 2250.

Setting Camera Properties for 3D Auto Tracking

Before analysing the 3D motion, you can define your camera properties. The camera represents the device used to acquire the sequence of images you are tracking. For each camera parameter, you can choose to let the auto 3D tracker calculate the value automatically or you can specify the value yourself. This information can help the auto 3D tracker calculate better results.

NOTE You can set the camera properties before initial tracking, or after initial tracking when calibrating or refining the track.

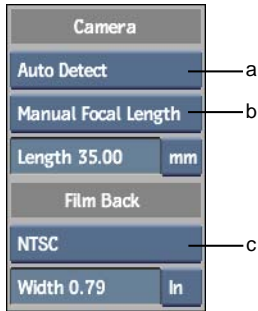

(a) Camera Type box (b) Focal Length box (c) Film Back box

The Camera and Film Back controls are described as follows.

Camera Type box Select the type of camera used to shoot the scene.

Select:	To:
Free 3D Motion	Track a clip shot with a free-moving camera.
Pan and Tilt	Track a rotating clip shot with a camera on a tripod.
Auto Detect	Automatically detect the camera type and track accordingly (default value).

Focal Length box If you know the properties of the camera that shot the scene, you can switch to Manual Focal Length, and set the length and film back settings.

NOTE Before initial tracking, if Zoom is enabled, Auto Focal Length is the only choice. In this case, you can switch to Manual Focal Length only after initial tracking to clean up the FOV animation before refining or calibrating.

Length field Enter the focal length.

Focal Length Units box Specify inches or millimeters to be used as the length.

Film Back box Select the film back size preset of the camera that shot the scene.

Width field Enter the width of the film back.

Width Units box Specify inches or millimeters to be used as the width.

Fine-tuning the 3D Auto Track

If the initial auto tracking does not give desired results, you can use some or all of the Filter options to calibrate and refine your track analysis. These procedures are not necessarily required, but depending on your image and the initial tracking, may give better tracking results.

To fine-tune the 3D auto track:

- 1 Use the Quality slider to adjust the number of good trackers kept. The higher the quality setting, more low quality trackers are selected, such as trackers that drift off their initial reference point. Click Delete to delete the selected trackers.



Trackers of lower quality may hinder the accuracy of the camera tracking.

NOTE After you have made a change that requires the 3D tracking analysis to be refined or calibrated, notice that the LED next to the Refine and Calibrate buttons turns yellow. This signifies that a Refine or Calibrate is required, but you do not have to perform it until you have completed your tracker selections.

- 2 Adjust the Short slider to select short duration trackers, that is, trackers that only track a feature for a few frames. Click Delete to delete the selected trackers, leaving the longer duration trackers intact.
- 3 You can manually select and delete trackers from the image that you feel are not tracking properly. Do one of the following:
 - To select an individual tracker, click the tracker, and then click Delete.
 - To select multiple trackers in the same area, **Ctrl**-drag a selection box over a series of trackers, and then click Delete.
 - To add another tracker to a multiple selection, **Shift**-click the tracker, and then click Delete.

- With Delete mode selected in the Edit Mode box, select trackers in the image.
- 4 If you want to add a tracker manually, enable Add and click an area of the image to track from this area automatically.

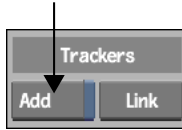

A tracker may or may not be added, depending on the ability of the track analysis algorithm to find an appropriate feature to track in this area.

- 5 If the analysis creates different trackers that refer to the same feature in the image, you can link these trackers. Press **Shift** and select two or more trackers from the image, and then click Link.

For example, an element leaving the scene at frame 28 and returning at frame 50 may result in two different trackers attached to the same element in the image. In this case, select the trackers and click Link to teach the algorithm that these trackers are the same.

To refine or calibrate the 3D track:

- 1 Depending on the changes you have made, you can choose to refine or calibrate the 3D track. Do one or both of the following:
 - Click Refine.

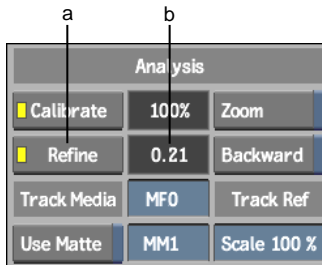

(a) Refine button (b) Pixel Error value

The track analysis uses the current results as a starting point, and refines from this point.

Click Refine again to stop the process once an acceptable pixel error value is reached. The pixel error value is a representation of the distance of the 2D tracks from the repositioned 3D points.

TIP The refine process is footage-dependant, so your acceptable pixel error value may change depending on what is tracking. Since the refine process continues until you stop it, as a general rule, if the pixel error value does not change for a length of time (for example, 30 seconds), you can stop the refine process. The lower the pixel error value, the more accurate the reconstructed track is.

- Click Calibrate.

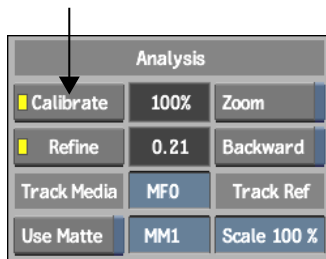

NOTE The calibrate operation deletes all previous points and starts over based on the new information. Depending on your footage, and how many trackers you added, deleted, or linked, multiple calibrations may yield different results.

Defining the Auto Track Ground Plane

Although it is not mandatory to define a ground plane in your image, it helps orient the reconstruction of the cameras.

To define the auto track ground plane:

- 1 Enable Define.

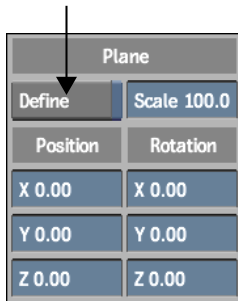

NOTE If you selected Pan and Tilt as the camera type (or if the Auto Detect switched to Pan and Tilt) the Plane Define button is not available. The rest of the settings in this group are still available, but only for orientation purposes.

- 2 Select a minimum of three points in the image that represent the plane of the X/Z axes, such as the ground, a table, or any flat surface.
The selected points appear as red squares with white crosses.

TIP You may want to disable the tracker temporarily and point display options (or raise the transparency level) to help you find and select the plane points. You can also change the plane display size from the Icons section.

- 3 Use the Position and Rotation controls to define the orientation of the ground plane.
- 4 Use the Scale field to specify the scale of the scene.
- 5 Disable Define.
The plane is displayed as a red grid.

Converting the 3D Auto Tracking Results

When you are satisfied with the results of the 3D auto tracking analysis, you can convert the selected reconstructed points to actual axes in your scene.

To create axes from the 3D tracking results:

- 1 Select the points in the image that you want converted to axes. Selected points are displayed as green squares with red crosses.
- 2 Click Create Axis.



Selected points are converted to axes with a parent Axis called *Points_3dt_sync*. The axes synchronize to the results of your auto 3D tracking, and any further changes you make to the 3D track are reflected in these axes.

NOTE If you want to apply settings manually to a synchronized axis, change its name so that it does not update automatically when 3D Track settings are changed. If you reset the 3D Track settings, the synchronized axes become regular Action axes.

- 3 Exit the 3D Track menu. Use the created axes to view the reconstructed camera motion.

Remember that it is the camera that is moving and not the points in the clip. You can attach objects such as surfaces, 3D text, and 3D models to the new axes to help position them in 3D space.

You can export the newly created camera, as well as the axes and points created from the 3D tracker analysis, to *.fbx* format for use in other 3D applications. See [FBX Cameras](#) on page 2229.

Manual 3D Tracking

Before you start manual 3D tracking, you should examine the clip closely to determine the points you want to track. The quality of the 2D track has a direct impact on the 3D tracking result, so it is important that you have a strategy for positioning the trackers in the clip sequence. Use the Stabilizer to track and stabilize the clip as accurately as possible. See [Tracking and Stabilizing](#) on page 1781.

For optimum results, each frame in the clip you are tracking must contain at least six track points. In the Stabilizer, this means six trackers are enabled. Also, at least two frames in the clip sequence must have a minimum of eight trackers, and these two reference frames should show the widest camera movement.

When tracking, the more track points you have in each frame, the smoother and more accurate the tracking result will be. As you place the trackers on the image, consider the following guidelines:

- Scatter the trackers by placing them on markings, corners, and shadows in the widest area possible. For example, avoid placing all trackers on the floor; place them on walls and other objects in the scene, as well as on the floor.
- Create a sense of depth by positioning trackers on points that lie in different planes, as well as on points located in the foreground and the background of the sequence.
- Avoid tracking points such as highlights or a point where the foreground and a background object meet, as they do not represent physical 3D points.
- Balance the number of trackers within each frame of the sequence so that as you move through the clip, some points leave the frame and other points appear in the frame. However, maintain a balance so that too many points do not leave or enter the frame at the same time.
- Avoid positioning the trackers in uniform areas or on linear edges where the track points may slide along the edge.

To set up manual trackers:

- 1 In Action, click 3D Track.
The 3D tracking controls appear.
- 2 From the 3D Tracker Option box, select Manual.



3 In the 3D tracking controls, click Stabilizer.

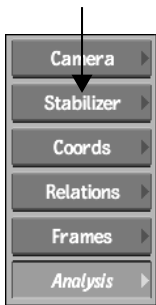

The Stabilizer menu appears.

4 Add trackers to the scene by clicking Add Tracker.

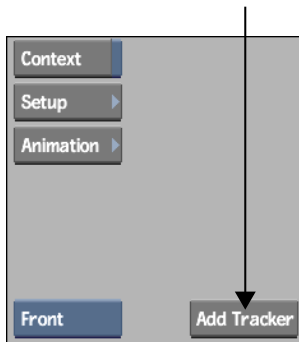

NOTE You can track points only on the back clip that you load in Action.

- 5 Drag each tracker to a position on the image following the guidelines described in [Basic Manual 3D Tracking](#) on page 2257.
You should have at least six trackers active at any one time, and at least two frames should have eight active trackers.
- 6 In the Stabilizer menu, click Analyse to process the 2D tracking path and check your result.
If the tracking is not correct, try standard tracking techniques as described in [Tracking and Stabilizing](#) on page 1781.
- 7 Click Return to return to the 3D tracking controls.

When you track a pattern that appears to drift or stray, you should set more intermediate trackers in the frames of the sequence, and ensure both the first and the last reference frames are set properly.

Basic Manual 3D Tracking

Manual 3D tracking is computed by generating an orientation based on the trackers you defined. This orientation is defined by keyframes. The manual 3D tracker creates keyframes with the 3D track points.

Once keyframes and 3D points are computed, the intermediate frames are computed by first interpolating between the keyframes, and then refining the camera properties using the estimated 3D point information.

You do not need to specify a coordinate system to create manual 3D tracking.

To compute basic manual tracking:

- 1 Define markers as described in [Manual 3D Tracking](#) on page 2254.

NOTE If the focal length is unknown, at least eight 3D points are needed. These points should not all lie on the same plane.

- 2 From the 3D Tracker option box, select Manual.
- 3 Click Frames to open the Frames menu.

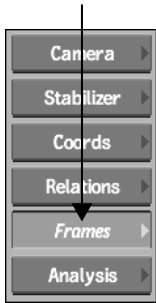

- 4 Click Initialise Frames.



Initialise Frames verifies that there are enough trackers in the scene and checks that there is enough spacing between the defined trackers. If you have not placed sufficient trackers in your scene, you will get an error message.

If you have enough trackers, the scene will be tracked and keyframes will be created for the camera. These keyframes can also be adjusted manually.

- 5 Click Analysis to open the Analysis menu.

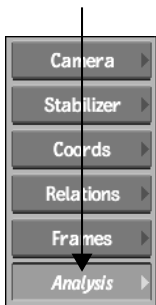

- 6 Click Track Camera to track points and process the 3D tracking result.

Tracker ▾	Residual ▾	Average ▾	Enabled	Reconstruct
Track 1	0.23221	0.30141	X	X
Track 2	0.11235	0.28009	X	X
Track 3	0.41693	0.55637	X	X
Track 4	0.44377	0.80539	X	X
Track 5	9.10120	8.91390	X	X

CurResidual 1.82 Threshold 1.000 AvResidual 1.252

Enabled Reconstruct Track Camera

Tracking the camera computes the 3D coordinates of the points that you tracked earlier. The manual 3D tracking analysis also calculates the tracking coordinates of the two reference frames, the keyframes, and all the frames in the clip.

In general, you should let the manual 3D tracker choose the keyframes when you click the Initialise Frames button. In cases where the camera motion is jittery, you can position the keyframes manually. Ideally, adjust your 2D tracks in the Stabilizer to ensure the camera motion is as smooth as possible.

You can change the number of keyframes and you can specify your own keyframes. If you specify your own keyframes:

- There should be enough keyframes to “cover” all the tracks. However, too many keyframes may slow the tracking process. Very few keyframes are needed, especially when the camera movement is very smooth.
- Keyframes should cover the movement in the sequence.
- There should be a keyframe each time a track “leaves” or “enters” an image.

NOTE A good 2D tracking result provides an excellent 3D track with keyframes set at every 5 frames or so.

Once the manual 3D tracking is computed, you can specify a coordinate system and apply it without resolving the tracking again. The camera and resulting axes are re-oriented without recomputing the tracking.

Advanced Manual 3D Tracking

If the basic manual tracking procedure is not as desired, or you want to tweak your results, you can perform several procedures to make your manual 3D

tracking more accurate. These procedures include the establishing of an origin, and setting references and relations between trackers.

You must establish an origin and a set of reference coordinates (x,y,z) to track the distance an object moves in space—similar to the Cartesian coordinate system where the origin is (0, 0, 0). All other track points are relative to the origin throughout the manual 3D tracking process.

NOTE Remember that it is the camera that is moving and not the points in the clip.

In Action, the distance between two objects helps define the scaling of the coordinate system. The change in distance between track points for each frame in a live-action clip determines how the 3D tracker will track an object.

When changing tracking coordinate settings, you do not need to retrack the camera.

After the manual 3D tracking is computed, you can specify a coordinate system and apply it without resolving the tracking again. The camera and resulting axes are re-oriented without recomputing the tracking.

Defining Coordinates

You specify the manual 3D tracking coordinate system and point of origin in the Coordinates menu.

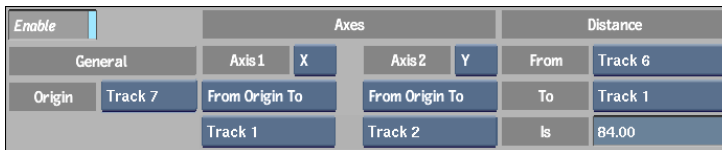

The Coordinates controls are described as follows.

Enable button Allows you to access the Coordinates controls.

Set button Applies the newly entered values in the Coordinate menu. The Set button is only visible once a successful tracking has been done.

Origin box Specifies the track point that sets the origin of the coordinate system. This should be a point that is easy to reference in the scene such as a point in the centre of the floor or the centre of a wall.

The Origin box lists the track points you added in the Stabilizer. If you added 12 track points to the scene, track points 1 through 12 are available in the list.

Distance boxes and Is field Selects the track points to use for establishing the 3D tracking scale in the coordinate system. In the Is field, type a value that best represents the actual distance between the two track points selected in the Distance boxes.

To set the origin and distance:

- 1 In the manual 3D tracking controls, click Coords.

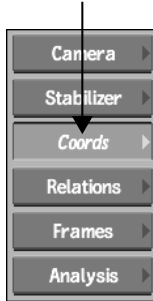

The Coordinates menu is displayed.

- 2 Click Enable to gain access to the Coordinates controls.
- 3 In the Origin box, select the track point that sets the origin of the coordinate system.
- 4 In the From box and To box of the Distance area, select the track points to use for measuring the distance and setting the 3D tracking scale for the coordinate system.
- 5 In the Is field, type a value for the distance between the From and To track points.

Because the camera distance and the field of view are directly related to the distance, consider the placement of the From and To track points with respect to the footage. Are the track points far in the back of the footage, such as on a building across a river? In this case, the value would be larger than, say, if the points were closer to the camera.

At first, you may have to try an approximate value and then experiment based on the results.

Defining Axes

You define a coordinate system to make it easier and more intuitive for inserting a virtual object or a 3D model in the scene. For example, if you want

to place a 3D model on a flat surface such as a table, you should specify two coordinate directions such as coordinate X and Z, which represent the plane of that surface. The 3D tracker determines the third axis to complete the 3D coordinate system.

When specifying the two coordinate directions, such as the X-axis and Z-axis, use one common track point for both axes to establish a true coordinate system.

NOTE Beware of negative and positive directions when specifying track points for the X, Y, or Z-axis. For example, if you specify points for the Y-axis, pick the track point whose Y-coordinate value is less than the second track point.

To define the axis:

- 1 In the Axes area of the Coordinates menu, set up a coordinate system by selecting one axis from the Axis1 box and another axis from the Axis2 box.

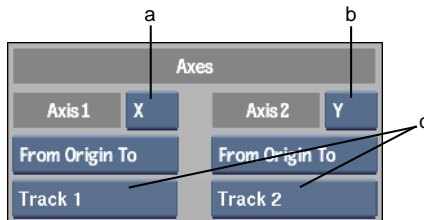

(a) Axis 1 box (b) Axis 2 box (c) Traversal Point boxes

- 2 From the Traversal Point boxes, for each axis, identify two points through which the selected axis passes.

Select:	To:
Through 2 Points	Specify the two track points through which Axis 1 or Axis 2 traverses.
From Origin To	Specify the track point through which Axis 1 or Axis 2 traverses including the origin track point.
Normal To 3 Points	Specify the three points in a plane that define the normal. The three points define the plane with which the normal is perpendicular. Use the right-hand method to determine the order.

Defining Relations between Track Points for Manual Tracking

To help the manual 3D tracker calculate relations between points, you can provide it with hints about the position and relationship of track points over several frames in a clip sequence. You establish track point relations by selecting the axes that track points have in common. Some track points can share the same Y-axis while a different set of track points can share the same X-axis value.

Define track point relations only after you obtain a result by setting up the 2D trackers and establishing a coordinate system. At that time you can experiment with a few relations and different camera properties until you are satisfied with your result.

For each track point in the scene whose coordinates you do know, you can create a point relation and specify its precision. For example, you may know the distance between these track points based on manual measurements or from a map. Create a point relation for each track point using a set of coordinates and set their Precision to variable or fixed, depending on the accuracy of the survey data. For example, two candlesticks on a table are at the same height above the table and a point relation would indicate that track points 3 and 4 share the Y-axis.

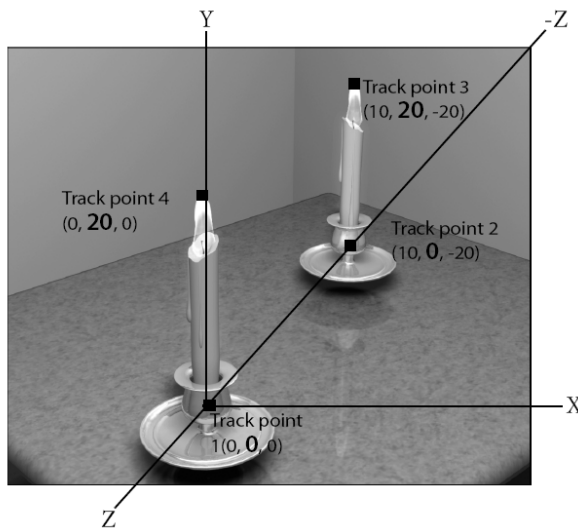

Avoid defining a point relation that has only one point and whose shared axis is Unknown as this provides little information to the 3D tracker.

You define track point relations in the Relations menu. The 3D tracker uses the enabled point relations.

To define track point relations:

- 1 In the 3D tracking manual controls, click Relations.

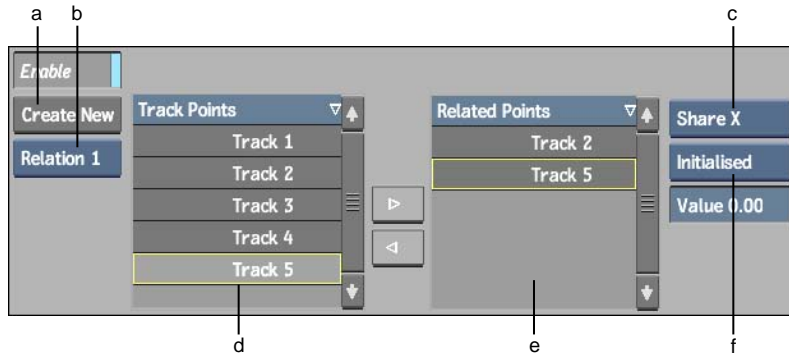

(a) Create New button (b) Relations box (c) Shared Axis box (d) Track Points column (e) Related Points column (f) Precision box

- 2 Click Create New to add a relation to the list of relations in the Relations box.

The first new relation you create appears in the Relation box and is enabled by default.

As you add new point relations, select the relation in the Relation box and click Enable to define or modify the relation. Try using different track points than the ones you used when defining the coordinates.

- 3 In the Track Points column, select a track point and click  to add it to the Related Points column.

The number of track points that appear in this column corresponds to the trackers that are enabled in the Stabilizer.

- 4 In the Shared Axis box, select the axis shared by the related track points: Share X, Share Y, or Share Z.

For the selected relation, the track points listed in the Related Points column share a common axis.

- 5 In the Precision box and Value field, select the value of the track point relation using one of the following precision types.

Select:	To:
Fixed	Keep the X or Y value that you specify in the Value field throughout the tracking. The 3D tracker does not modify this value. For example, when you select Share X, the Y value remains constant for the related points. This is the default.
Initialised	Estimate the value of the track point starting with the initial value that you specify in the Value field.
Unknown	Compute the value of the track points automatically with the 3D tracker without specifying a value.

- 6 Click Enable.

A track point can belong to several point relations: Share X, Share Y, or Share Z, but only one relation can be enabled at a time. If you try to enable a point relation that contains a track point already existing in another point relation, a message appears indicating the first point relation is disabled. For example, Relation 1 is defined by track 1 and track 2 that have a Share X relation. If you try to create another relation, Relation 2 for track 1 and track 2, you are prompted that Relation 1 will be disabled.

NOTE If you already tracked the camera and later changed the trackers relations, you need to retrack the camera. See [Analysing Manual 3D Tracks](#) on page 2270 for more information.

Setting Camera Properties for Manual Tracking

Before analysing the manual 3D motion and tracking, you may want to define your camera. The camera represents the device used to acquire the sequence of images you are tracking. Typically, when you load a clip, the camera position, field of view (FOV), and point of interest (POI) are assigned to each frame in the clip by default. For the purposes of 3D tracking, a camera is characterized by its internal properties: the principle point, the pixel aspect ratio, the focal length, and the non-linear distortion.

The manual 3D tracker handles most camera motions including zoom, even when only a small change in position or direction of an object is caused by a

change in the point of observation. For each camera parameter, you can choose to let the 3D tracker calculate the value automatically or you can specify the value yourself.

NOTE If you changed the camera properties after tracking the camera, you need to retrack the camera. See [Analysing Manual 3D Tracks](#) on page 2270.

Defining the Camera

If you already have information about the camera, you can specify this information before using the manual 3D tracker. When you provide information about the camera, the calculation and rendering is much faster than when the tracker has to calculate the properties itself.

To define the camera:

- 1 In the manual 3D Track menu, click Camera.
The Camera controls appear.
- 2 In the Film Back section, specify the camera film back.

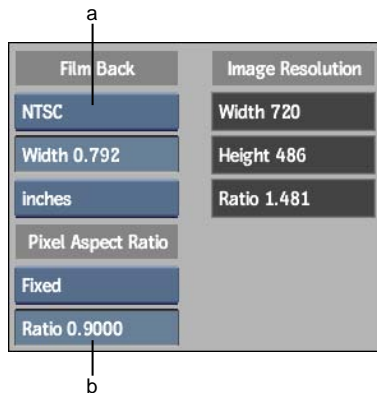

(a) Film Back box (b) Aspect Ratio box

Use:	To:
Film Back box	Specify the image resolution.
Width field	Specify the width of the film back.
Units box	Identify the unit of measure: inches or millimeters.

The image resolution values change according to the Film Back settings.

- 3 Select an Aspect Ratio. You can define a fixed value, or use one of the following solving options.

Select:	To:
Constant Initialised	Let the 3D tracker estimate the value, starting from an approximate value that you specify. The value remains constant for all the frames in the sequence.
Constant Unknown	Let the 3D tracker compute the value and keep the value constant for all the frames in the sequence.
Variable Initialised	Let the 3D tracker estimate the value, starting from an approximate value that you provide. The value can change across the frames.
Variable Unknown	Let the 3D tracker compute the value with no input from you. The value can change across the frames.
Fixed	Use the value you provide with no modifications made by the 3D tracker.

Setting the Focal Length

Setting focal length constraints tells the manual 3D tracker that the focal length is constant throughout the clip sequence. If you know the film back and the camera, you can allow the 3D tracker to calculate the focal length automatically by setting it to Constant Initialised.

The film back sets the field of view and might change the focal length and distance of the camera from the scene; however, it should not affect the quality of the shot.

Viewing the scene from the Side view lets you see the frustum more clearly. In this way you can view the camera and the scene.

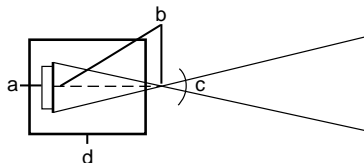

(a) film back (b) focal length (c) field of view (FOV) (d) camera

To set the focal length:

- 1 From the Focal Length box, select the focal length.

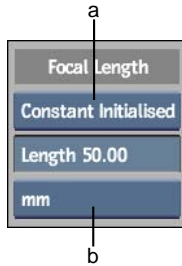

(a) Focal Length box (b) Units box

NOTE Use the Variable options for camera zoom; if you do not know the camera, use Constant Initialised.

- 2 In the Length field, enter the focal length and then select millimeters or inches in the Units box.

Setting Camera Distortion

The manual 3D tracker uses lens distortion so that tracking points that are positioned far from the principle point—or the centre of the image—are taken into account. The distortion is a radial value measured from the centre of the principle point.

If the footage you are tracking contains a lot of lens distortion—perhaps due to a very wide angle lens—set the distortion with respect to the principle point so that track points in distorted areas are tracked accurately by the manual 3D tracker.

To set camera distortion:

- 1 From the Principle Point box, select one of the following.

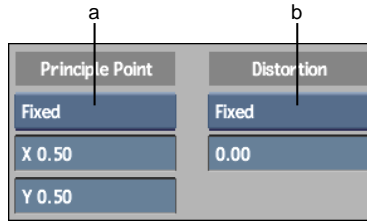

(a) Principle point (b) Distortion point

Select:	To:
Fixed	Specify a principle point whose position does not change. Select this when you know the position.
Constant Initialised	Specify an estimated value for the principle point whose position does not change. Select this if you do not know where the principle point is, for instance, if the image is cropped.
Constant Unknown	Let the 3D tracker determine the principle point. Select this only after you analyse the 3D track using Constant Initialised and you are not satisfied with the result. If you are still not satisfied with the result after using Constant Unknown, try setting a few track point relations and use Constant Initialised again.

2 In the Principle Point X and Y fields, enter the X and Y coordinates in pixels of the principle point.

A value of 0,0 corresponds to the lower-left corner of the image.

3 From the Distortion box, select the lens distortion as follows.

Select:	To:
Fixed	Specify a distortion whose value does not change.
Constant Initialised	Specify an estimated value for the distortion that does not change.
Constant Unknown	Let the manual 3D tracker determine the distortion.

4 In the Distortion field, enter a value for the distortion.

NOTE The distortion is 0 at the location of the principle point.

Analysing Manual 3D Tracks

The manual 3D tracking process computes the camera properties and reconstructs the 3D coordinates of the 2D points that are tracked in the Stabilizer. The manual 3D tracking analysis also calculates the tracking coordinates of the two reference frames, the keyframes, and all the frames in the clip.

Most errors result from a poorly tracked clip in the Stabilizer or when coordinates are set incorrectly.

Use the Analysis menu to finalize the manual 3D tracking process by fine-tuning the trackers. To access the Analysis menu, click Analysis.

Tracker	Residual	Average	Enabled	Reconstruct
Track 1	0.23221	0.30141	X	X
Track 2	0.11235	0.28009	X	X
Track 3	0.41693	0.55637	X	X
Track 4	0.44377	0.80539	X	X
Track 5	9.10120	8.91390	X	X

CurResidual 1.82 Threshold 1.000 AvResidual 1.252

Enabled Reconstruct Track Camera

The Analysis controls are described as follows.

Track Camera button Tracks the 3D track points and processes the 3D tracking result.

Residual column Determines the difference in pixels between the 2D track and the calculated 3D track for each tracker in the clip sequence.

The value shown in the Residual column represents the difference in precision between the 2D track and the 3D track at the current frame.

Average column Shows the average residual of the tracker over all frames in the clip.

CurResidual field Shows the average residual of the selected tracker at the current frame.

Tracker column Represents each tracker in the Stabilizer and each track point in the 3D tracking scene.

Enabled button Activates or deactivates the tracker in the scene.

Threshold field Sets a threshold value so that a red indicator appears in the timebar at frames where the average residual exceeds this value.

Reconstruct button Creates an axis in 3D space for the selected tracker.

To track the 3D camera and analyse the 3D tracking results:

- 1 In the manual 3D tracking menu, click Analysis.
- 2 In the Analysis menu, click Track Camera.
- 3 For each tracker, peruse the residual and average residual values.
Look at the 3D axes of your track points and determine if their appearance is viable for the 3D track. The coordinates of each track point axis should point in the directions you expect.
- 4 If the average residual value for a particular tracker exceeds the threshold, disable Enabled for the tracker. You can repeat this step for more than one tracker.
- 5 If you want to reanalyse the manual 3D track, in the schematic, delete all track Axis nodes.

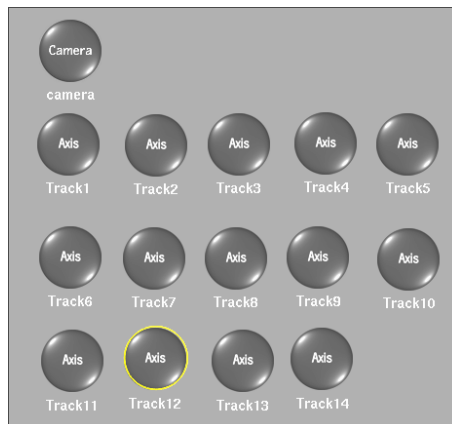

- 6 If necessary, go to the Stabilizer and revise a few 2D trackers.
- 7 Go to the Coordinates menu and verify the coordinate system.
- 8 Return to the Frames menu, click Initialise Frames.
- 9 In the Analysis menu, click Track Camera.

Action: 3D Geometry

77

Topics in this chapter:

- [About 3D Geometry](#) on page 2273
- [Importing 3D Models](#) on page 2274
- [Working with 3D Geometry](#) on page 2278
- [Adding Textures](#) on page 2284
- [Deforming Models and Surfaces](#) on page 2296
- [Creating 3D Text](#) on page 2300
- [Using Garbage Masks as 3D Geometry](#) on page 2305

About 3D Geometry

In Action, 3D geometry consists of 3D models and 3D text. A powerful feature of Action is its ability to import 3D models created in other applications and combine them with existing clips. Compositing 3D models and characters with other media or a background can be done quickly and with a finite level of control.

3D geometric objects are manipulated like an image or a clip: you can animate their position and shape, apply textures and media, and light objects to produce a variety of effects.

Importing 3D Models

You can import 3D polygon objects such as 3ds Max files, FBX files, Wavefront files, Inventor files, garbage masks, and Paint geometry. 3ds Max files contain object data, specifically, texture and materials. The FBX format acts as the intermediary between different file types. Files can be exported from another product to the FBX format and then imported into Flame.

NOTE A library of 3ds Max 3D models is located in the *usr/discreet/<product home>/models* library. All models are textured with an identical image found in the same directory. The library consists mostly of various geometric shapes such as cubes, cylinders, and spheres.

Paint geometry files are created by the Flame Paint module. If you want to work with polygon geometry in Action, import Paint geometry. Action ignores its animation and attributes, such as its colour, outline, and gradient. For example, in Paint, if you create a blue polygon, animate its scale, and save it as geometry, it is imported in Action as a white polygon with no animation.

You can import a 3D model into one or several geometry nodes. You can also import multiple 3D models into a single animated geometry node.

To import a 3D model:

- 1 Do one of the following:
 - Drag the Import node from the node bar and place it in the schematic.
 - Drag the Import node from the node bar and place it where you want it in Result view.
 - Double-click the Import node. You do not need to be in Schematic view to add a node in this manner.

The Import menu and file browser appear.

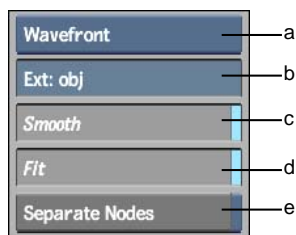

(a) Import Type box (b) File Extension field (c) Smooth button (d) Fit button (e) Separate Nodes button

The Import controls are described as follows.

Import Type box Displays the 3D model you want to import: FBX, Wavefront, Inventor, 3DStudio, Paint, or Photoshop.

File Extension field Specifies a particular file extension for FBX, Wavefront, Inventor, or 3DStudio files. By default, Wavefront files have *.obj*, Inventor files have *.iv*, FBX files have *.fbx*, and 3D Studio files have *.3ds* as their file extensions.

NOTE When selecting Paint, GMask, or Photoshop, the subsequent controls described in this section do not apply. When selecting FBX, other controls appear. See [Importing the FBX Format](#) on page 2277.

Smooth button Builds normals for the 3D model. Enable this button if you are importing polygons that do not have normals.

Fit button Scales the imported model to fit into the current frame. When this button is disabled, the imported model maintains the same size in which it was created using a third-party application.

Separate Nodes button Creates individual nodes for all 3D models contained in a file.

When this button is disabled, the 3D model is added to the scene with its own axis.

Rotate Axis button Rotates the imported 3D model by 90 degrees on the X-axis so that it is compatible with Action's coordinate system. This button appears only when 3DStudio is selected as the import format.

- 2 From the Import Type box, select the import format.
- 3 If the file you want to import has a file extension different from the one specified, type a file extension.
- 4 Enable Smooth or Fit as needed.
- 5 Select the file to import from the file browser.
- 6 Click Load.

The 3D model is added to the scene.

You can change the 3D model's colour, specular highlight, shine, and other material properties. See [Working with 3D Geometry](#) on page 2278.

To import multiple 3D models into an animated sequence:

- 1 Follow the same steps for adding a single 3D model, but from the Import file browser, select multiple 3D models by holding the **Shift** or **Ctrl** key.
- 2 Once the models are selected, click Load.
The selected 3D models are loaded to the same line in the Media list.
- 3 Double-click the Geometry node in the schematic to access the Geometry menu.
The Animation Mode, Hold, and Slip buttons appear in the Geometry menu.

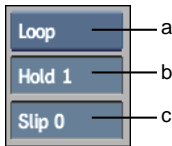

(a) Animation Mode box (b) Hold field (c) Slip field

- 4 Set the Animation mode.

Select:	To:
Loop	Play in a continuous loop.
Once	Play once. The 3D geometry is no longer displayed.
Last Still	Play once, and hold the last frame.
Timing	Animate according to the timing in the animation channel.

- 5 If you selected Loop, Once or Last Still, set the Hold value to determine the number of continuous frames to display, and set the Slip value to offset the start point. If you selected Timing, go to the next step.
- 6 If you selected Timing, set the value for that frame in the Timing curve using the Frame Timing field.

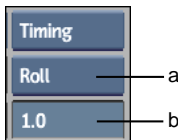

(a) Timing Range option (b) Frame Timing field

- 7 Set the Timing Range option to determine how Frame Timing values outside the timing range of the animation are handled.

Select:	To:
Roll	Roll over the Frame Timing value.
Cut	(Geometry is not displayed.)
Round	Display the first or last geometry (with this option, you can select the first and the last geometry of your animation).

Importing the FBX Format

Flame supports the import of 3D data saved in the Alias FBX format.

The FBX standard format provides a means for exchanging 3D data—3D polygonal models, cameras, lights, keyframe animation—for scene compositions between tools and packages developed by different manufacturers.

FBX support makes it possible to import and export 3ds Max, Alias Wavefront, Maya, Softimage XSI, and LightWave 3D formats. You can import models, scene compositions, lights, and camera data.

You can also export camera data. See [Importing and Exporting Cameras](#) on page 2229 for information on how to export an FBX camera.

To import FBX format data:

- 1 In the Import menu, select FBX as your format type.

NOTE Only polygonal models can be imported into Flame. Nurbs and skins, for example, are not supported.

- 2 Select which type or combination of types of FBX files you wish to display by clicking the corresponding filter button.

Enable:	To:
Lights	Import lights from the FBX format file.
Cameras	Import cameras from the FBX format file. Free cameras are imported as target cameras (with a point of interest).

Enable:	To:
Models	Import models and 3D geometry from the FBX format file.
Normals	Import the models' normal information.

- 3 To use the frame rate of the FBX file as the frame rate in Action, enable Keep FBX Frame Rate.

TIP It might be useful to enable Keep FBX Frame Rate when importing an FBX file before starting to build your animation, otherwise the timing of your animation may be affected.

- 4 To add a keyframe at every frame of the imported FBX file, enable Bake FBX Animation. When disabled, Flame translates the FBX keyframes to a comparable animation curve in Action. Experiment with this option enabled and disabled to get your desired results.
- 5 Navigate to the location where the FBX files are located.

NOTE Make sure that any textures referenced by the FBX files are in the same directory you are importing from.

- 6 Select a file from the file browser.
- 7 Click Load.

The FBX data is imported into Action.

Working with 3D Geometry

You can change and animate parameters such as the colour, specular highlight, shine, and transparency of 3D models. You set these parameters using the Geometry menu. To access this menu, double-click a Geometry node in the schematic, or follow the tab population rules for the Object menu (see [Selecting Objects and Populating Menu Tabs](#) on page 2102).

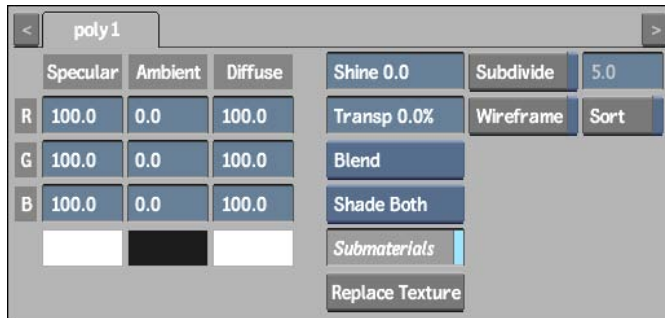

The Geometry controls are described as follows.

Specular fields Set the colour of light reflected by the 3D model's surface. To enable the specular highlight, the Shine value must be larger than zero. Enter values in the Specular red, green, and blue channel fields or use the colour picker.

Ambient fields Set colour to the area of the 3D model that is not illuminated by a direct light source. The edge of the ambient area mixes with the specular highlight colour and the diffuse colour. Enter values in the Ambient red, green, and blue channel fields or use the colour picker.

Diffuse fields Modify the colour and illumination of the entire 3D model. Diffuse light mixes with the colour of the light sources used to illuminate the 3D model. The diffuse colour may also mix with the ambient colour and the colour of the specular highlight.

Change the colour of the 3D model by entering values in the Diffuse red, green, and blue channel fields or by using the colour picker.

Shine field Sets the intensity of the specular highlight. When this value is zero, the specular highlight is disabled. Shine affects both size and intensity. See [Creating a Specular Highlight on a Model](#) on page 2280.

Transp field Increases or decreases the transparency of the 3D model or text.

Blend box Uses a regular blend to composite the object in the scene. Alternatively, you can use additive blend to add the colours of the object to the colours of what lies behind it. You may have to change transparency to see the effect.

Sort Order box Sorts the drawing priority of the 3D model normals either back-to-front or front-to-back.

Select: **To:**

Shade Both Draw the polygons that are both facing and opposite the camera.

Shade Front Draw the polygons facing the camera last.

Shade Back Draw the polygons opposite the camera last. This option is especially useful for semi-transparent models

Submaterials button Uses materials imported with 3ds Max models only.

Replace Texture button Replaces an existing texture on an imported model that already has a defined submaterial.

Subdivide button and field Create high-quality shading for polygon models. Use the Subdivide field to enter the maximum polygon side length.

Wireframe button Displays your model or 3D text as a wireframe outline only. When you render the 3D model or text with Wireframe enabled, it retains its light, shading, and texture attributes.

Sort button Determines how the 3D model or text is drawn according to its normals.

Creating a Specular Highlight on a Model

Change the specular colour by entering values in the Specular red, green, and blue channel fields or using the colour picker. For example, if the specular colour is red and the light source is white, the specular highlight is also red. If the specular colour is yellow and the light source is red, the highlight is orange.

To use a specular highlight with a 3D model:

- 1 Add and position a light source in the scene.
- 2 In the scene, select the 3D model to which you want to add the highlight.
- 3 In the Action Setup menu, enable Shading and disable Texture.

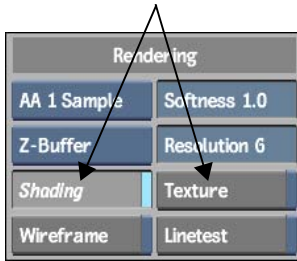

- 4 In the Geometry menu, set a value in the Shine field.

A high Shine value produces a dimmer highlight while a low Shine value produces an intense highlight. When the Shine field is set to zero, the 3D model does not have a highlight. The following example shows the same 3D model using two different Shine values.

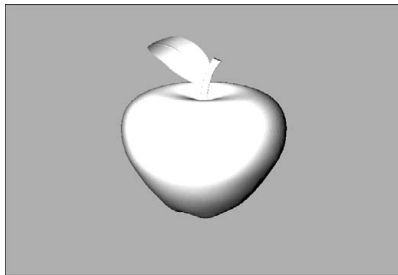

Shine is set to 1. The specular highlight is intense.

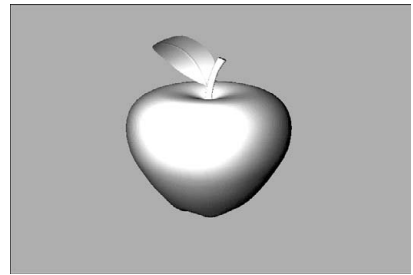

Shine is set to 20. The specular highlight is dimmer.

Adjusting Normals

When using transparency with 3D models, you may sometimes see the back polygons, giving the model a shattered or broken look. This happens when the drawing priority of the normals is not sorted properly. Enable Sort and

select an option from the Sort Order box to sort the drawing priority back to front or front to back.

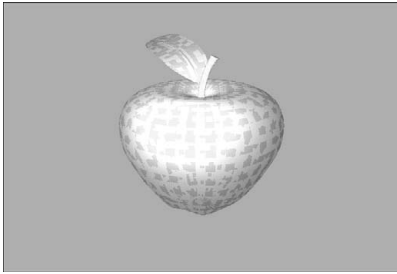

Drawing order of the 3D model's polygons is incorrect. Back polygons are drawn through when the model is transparent.

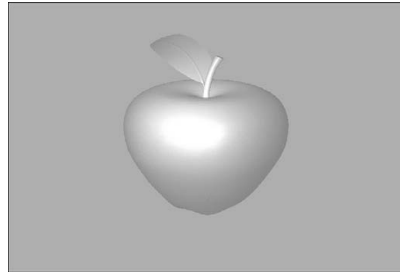

Select Front to sort the polygons front to back. The transparency is drawn correctly.

Subdividing a Model

The Subdivide feature is useful for creating precise highlights and spotlights. The polygons in the 3D model are subdivided at the time of render according to the value you specify, resulting in smoother rendered surfaces.

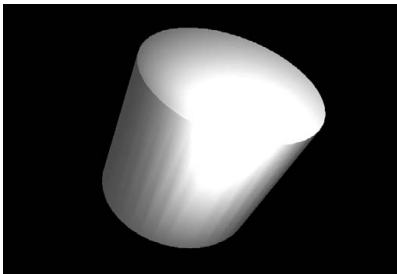

Spotlight on a polygon model rendered with Subdivide off.

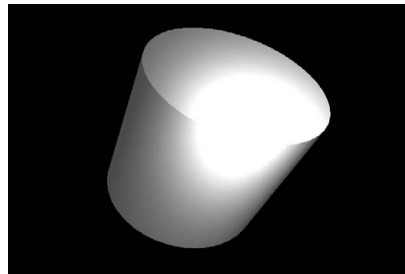

Spotlight on a polygon model rendered with Subdivide set to 2.

To subdivide a model:

- 1 Select the model or geometry you want to subdivide.
- 2 In the Geometry menu, click Subdivide to enable the Subdivide field.
- 3 Edit the Subdivide value. The default value is 5.

NOTE The smaller the value, the slower the rendering.

- 4 Click Process or Preview to see the subdivision effect.

You can animate the Subdivide channel in the Channel Editor; however, expect a longer rendering time when the Subdivide value changes over several keyframes.

Setting Surface Resolution

When you use Action, you work with geometry surface resolution. Surface resolution is set using the Resolution field and Linetest button in the Rendering Settings section of the Action Setup menu. You can vary the resolution according to the animation you add to the clip and use Linetest to check it. If you use texture, full resolution texture is used while you work. The image in the image window is displayed at full resolution when you preview or process the clip. You can also set a render resolution from the Action Setup Resolution Settings menu. See [Resolution Settings](#) on page 2116.

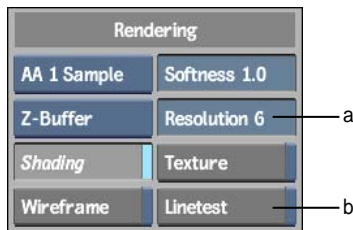

(a) Resolution field (b) Linetest button

To generate a clip at a lower resolution:

- 1 In the Rendering section of Action Setup menu, disable Texture. Surface media mapping occurs according to the value in the Resolution field.
- 2 In the Resolution field, enter a value. You may want to increase the quality by entering a small value, particularly if you are using lighting, shading, particle explosions, or displacement.

NOTE To see what happens as you experiment with the Resolution value, add a bicubic surface to the scene and enable Wireframe. Notice the number of surface polygons as you increase and decrease the Resolution value.

- 3 Enable Linetest.
- 4 Click Process to render the animation.

The animation is rendered at the resolution that you entered in the Resolution field.

NOTE Motion blur and anti-aliasing are ignored, but global rendering—either Fields or Frames— is used.

Adding Textures

You can apply a texture to a surface, 3D model, or 3D text. You can move, rotate, scale, and animate the texture independently from the surface, 3D model, or 3D text. Since the texture and its axis are parented by the geometry node, animating the geometry's axis also animates the texture, which has the effect of keeping the texture properly in place on the model. A texture uses the specular highlight, diffuse colour, and shine set by its parent.

When adding a texture to a shaded surface, the texture is used when generating the shadow. The texture is only used to apply the colour to the shadow, so effects such as surface displacement will still reference the media associated with the surface. If a node has an applied texture, it is the matte setting of the texture that controls whether the object will be included in the various output mattes (scene matte, blend matte, for example).

To add a texture:

- 1 In the schematic, select the surface, 3D model, or 3D text to which you want to apply the texture.
- 2 In Action, click Media.
- 3 In the Media menu, select the media you want to use for the texture.
A texture uses the front and matte of the media. If you do not want to apply transparency to your texture, turn its matte off.
- 4 Do one of the following:
 - Drag the Texture node from the node bar and place it in the schematic.
 - Drag the Texture node from the node bar and place it where you want it in Result view.

- Double-click the Texture node. You do not need to be in Schematic view to add a node in this manner.

The texture object is added to the schematic with its own parent axis. The new axis is the child of the selected 3D model.

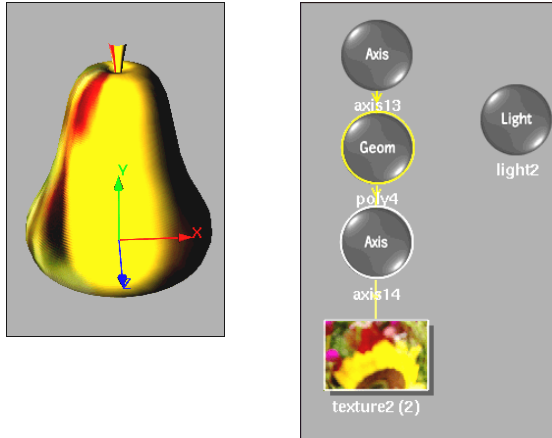

- 5 Double-click the Texture node in the schematic, or follow the tab population rules for the Object menu (see [Selecting Objects and Populating Menu Tabs](#) on page 2102). The Texture menu appears.
- 6 Select the texture and set texture properties as described in [Applying Texture Mapping](#) on page 2286.

Replacing a Texture on a Model

If you imported a 3ds Max model that has a texture applied to it, you can replace the texture. You are limited to one texture load per model. Flame supports several image formats including Tiff, SGI, and JPEG.

To replace a texture on a 3ds Max model:

- 1 In the schematic, select the 3ds Max model that will have its texture replaced.
- 2 In the Geometry menu, click Replace Texture.

The Import Image browser appears prompting you to select an image file.

3 Navigate to the folder in which your image file is located.

4 Click Load.

You return to the Action module and the texture is applied to the model(s).

Applying Texture Mapping

When you apply a texture, Action lines up the lower-left corner of the texture (coordinates 0, 0) with the centre point of the front plane of the geometry. For example, the following figure shows how Action initially aligns a planar texture to a cube.

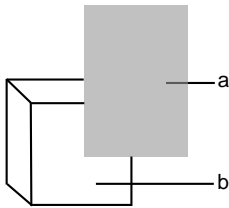

(a) Planar texture (b) Front plane of 3D geometry

Because a texture is added with its own axis, you can use this axis to offset the texture from the centre of the geometry. You can also rotate and scale the texture.

The initial placement of the texture is most evident when you use planar texture mapping. You can map textures to 3D models using reflection, planar, wrap, or cylindrical mapping.

Reflection

Reflection mapping mode applies the 2D texture as though the 3D model is reflecting the texture. This type of mapping uses the surface normals of the geometry to generate texture values and the texture is reflected onto the 3D model.

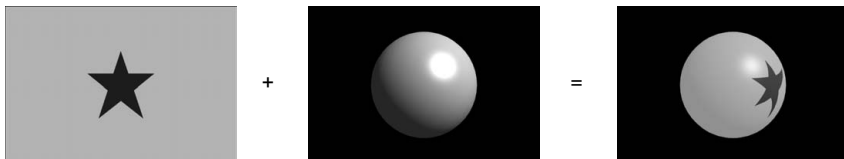

Reflection mapping sometimes distorts or scales the texture, since it is wrapped around the entire object. If you move the 3D model, the texture slides on the object.

Planar

Planar mapping applies the texture without distorting the front plane of the 3D model, similar to a movie projector casting an image onto a screen. All 3D coordinates of the geometry are mapped to this plane to generate the texture values. Planar mapping positions the lower-left corner of the texture on the 3D model's axis.



When you apply planar mapping, any surfaces on the 3D model perpendicular to the front plane cause the pixels at the edge of the texture to project along the “sides” of the object.

Wrap

Wrap mapping completely envelops the 3D model with the texture according to the object's texture coordinates. To use this option, you must import a model that has its own texture coordinates.

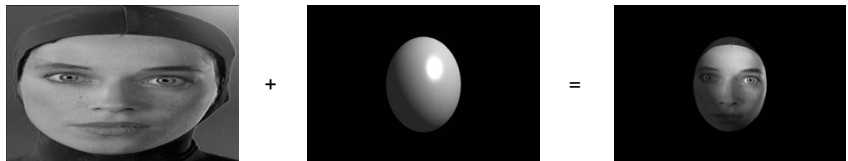

NOTE If the 3D model has no texture coordinates and you choose wrap mapping mode, the texture reverts to planar mapping mode.

Cylindrical

Cylindrical mapping wraps the texture around the 3D model in a cylindrical manner, starting from the lower-left corner of the texture. Use cylindrical mapping for models of cans, bottles, or other circular and semicircular bodies.

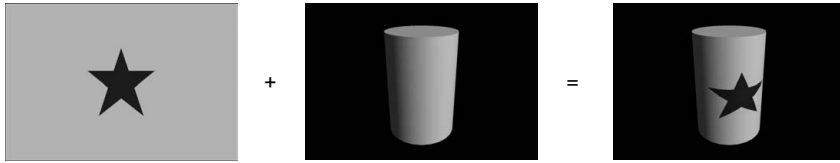

Cylindrical texture mapping is oriented counterclockwise—left-to-right—when viewed from the top of the model.

To apply texture mapping:

- 1 From the schematic, select the texture to which you want to apply different texture mapping.
- 2 In the Rendering section of the Action Setup menu, enable or disable Shading depending on the method of texture mapping you are using. When Shading is enabled, normals are used. You must enable Shading when using Reflection mapping because it also uses normals.
- 3 In the Texture menu, select the texture mapping from the Mapping box.

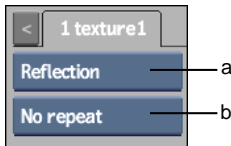

(a) Mapping box (b) Repeat Mode box

- 4 Select the repeat mode for the texture.

Select:	To:
No Repeat	Use the texture once, without repeating it over the surface.
Repeat (fast)	Repeat the texture to fill the surface. If the surface is larger than the texture, or you scale down the size of the texture, the texture will repeat to cover the entire surface. This option gives a slightly lower quality result, but with faster processing time.
Repeat (smooth)	Repeat the texture to fill the surface. If the surface is larger than the texture, or you scale down the size of the texture, the texture will repeat to cover the entire surface. This option gives better results but with slightly longer processing time.

Converting to Wireframe

You can remove the texture for a selected surface using the Wireframe button. When Wireframe is enabled, textures are replaced with a wireframe view of the surface. When used, a 3D model will be changed to show its polygon frame.

To convert to wireframe:

- 1 In the scene, select the surface to convert to wireframe.
- 2 In the Geometry menu, enable Wireframe.

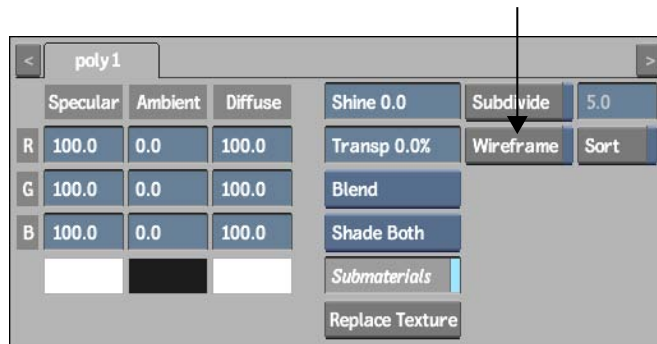

The selected surface becomes a wireframe surface.

Projecting Textures

Like a slide projector, textures can be projected onto 3D models and 3D text to create an effect where a texture is animated on an object in 3D space. The advantage of using a Projector node is that you can cast images on arbitrary surfaces. You can create a spotlight texture and project it onto a 3D model, so that you can see “into” it.

The texture projection properties are located in the Projector menu.



The Projector controls are described as follows.

MBlur Enables or disables a motion blur only for the projection.

Enable button Activates or deactivates the projected texture effect in the scene. When this button is disabled, the Projector node remains in the schematic and the projector icon appears smaller in the image area.

Position X, Y, and Z fields Position the projector in 3D space. You can also set the texture projector position by dragging the projector in the scene.

Rotation X, Y, and Z fields Rotate the projector in 3D space.

Motion Path button Enables motion path animation for the projector.

Projection Blend Mode box Displays the projected texture effect. See [Blending Projections](#) on page 2292.

Transparency field Modifies the transparency of the projected texture effect. Transparency values are 0 to 100.

FOV field Adjusts the projector's field of view. FOV values are 1.00 to 180.00.

Aspect field Specifies the ratio of height to width for the projected image. Aspect values are 0.10 to 100.00.

Order field Sets the order of projectors.

RGB fields and colour pot Specify RGB colour values. You can also pick a colour with the colour picker.

To project a texture:

- 1 In Action, click Media to access the Media menu.
- 2 In the Media list, select the media that you want to project.
- 3 Do one of the following:
 - Drag the Projector node from the node bar and place it in the schematic.

- Drag the Projector node from the node bar and place it where you want it in Result view.
- Double-click the Projector node. You do not need to be in Schematic view to add a node in this manner.

The Projector node appears in the schematic and a projector icon appears in the scene.

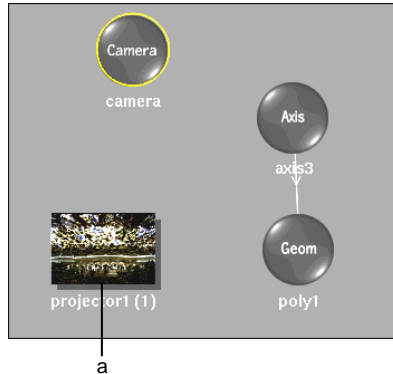

(a) Projector node

- 4 Double-click the Projector node to display the Projector menu, or follow the tab population rules for the Object menu (see [Selecting Objects and Populating Menu Tabs](#) on page 2102).
The Projector is selected.
- 5 Switch to Camera view to manipulate the projector in the scene using the View box.
The following example illustrates projected media on a 3D model using Spotlight projection blend mode. See [Blending Projections](#) on page 2292.

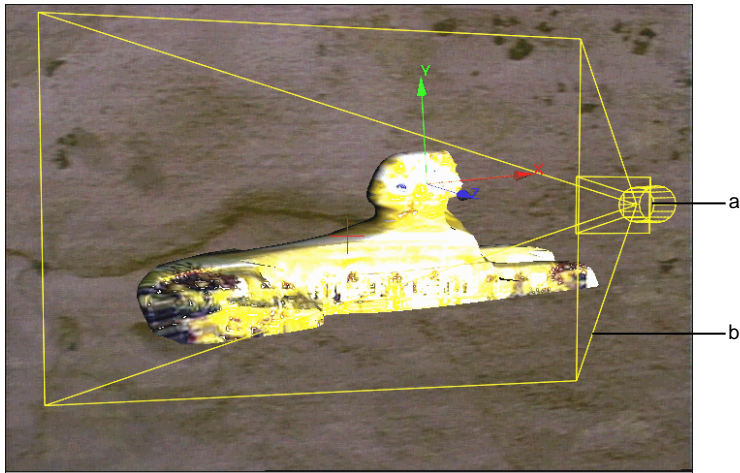

(a) Projector icon (b) Yellow outline shows the projector field of view

To add multiple projections:

- 1 In Action, click Media to access the Media menu.
- 2 In the Media list, select the media you want to use as projectors by **Ctrl**-clicking the media.
- 3 Use the node bin to add a projector.
Multiple Projector nodes appear in the schematic and projector icons appear in the scene.
- 4 Use the Order field in the Projector menu to set the order of projectors.
The front projector is projector1. A new projector is always added to the back. Changing the order number of a projector affects the order of other projectors.

Blending Projections

Use projection blend modes to modify how you want to blend the projected image in the scene. Select a mode from the Projection Blend Mode box.

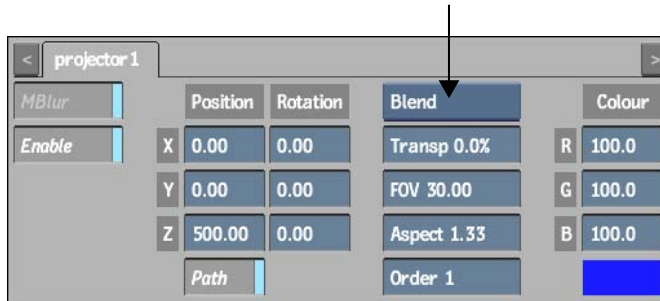

Add Compensates for the soft or anti-aliased edge on an object in a front and matte clip media.

Blend Punches the matte through the front. This blends the edge of the front clip and adds additional softness to the media. This is the default setting. Use Blend mode when you do not want any shading cast on the geometries that are receiving the projection.

Max Compares the RGB channels of each pixel of the front clip and the back clip individually and returns the larger of the two values.

Min Compares the RGB channels of each pixel of the front clip and the back clip individually and returns the smaller of the two values.

Multiply Multiplies the RGB channel values of corresponding pixels of the front clip and the matte clip, and normalizes the result by dividing by 256 in 8-bit mode, or 4096 in 12-bit mode. The resulting RGB channel values are assigned to the corresponding pixels in the generated clip.

Hardware limitations may prevent transparency from working properly with Multiply.

Negate Creates a negative-like result. Try Negate with a soft white matte with a white front clip. This mode does not use the matte or transparency in its blend.

Screen Multiplies the inverse of the matte clip's colours with the colours of the front clip. The resulting colour is always lighter. Screen does not work with transparency.

When using a matte, set the diffuse r, g, b channels to 0, 0, 0 in the Channel Editor for the image surface you are blending.

Simple Add Punches the matte through the front using more softness than Blend mode. Simple Add mode is similar to Add but includes transparency.

Spotlight Creates a slide projector effect. This mode does not use the matte or transparency and decreases system performance.

Spotlight Blend Creates an effect where black areas of the front disappear. This mode does not use the matte or transparency; it works well with a clip on which an object is surrounded by black.

Subtract Subtracts the RGB channel values of the pixels in the matte clip from the RGB channel values of the pixels in the front clip and assigns the result to the RGB channel values of the pixel in the result.

If an RGB channel value from the matte clip is larger than the corresponding channel value in the front clip, yielding a negative result, that result is clamped at 0 (black).

Applying Selective Projections

You can use projections selectively; either inclusively or exclusively. Similarly to the Selective Lighting feature, you can connect a projection to an image, object, or its axis and make the projection affect only that connection (inclusive). Conversely, a projection that affects every object *except* the one it is connected to is exclusive.

To use selective projections, you must have a scene with a minimum of two objects in order for the selective projection to affect one and not the other.

To create an inclusive selective projection:

- 1 Select the media to use as a texture for projection.
- 2 Add a projector using the Node bin.
The projection is added to the scene.
- 3 To make the projection selective, access the schematic by using the ~ key or by selecting Schematic from the View box.
In the schematic, the projector is displayed much like an image. By default, it projects an image across the entire scene.
- 4 Select Lighting from the Edit Mode box to create lighting connections.



5 Do one of the following:

- To project only a selected surface, drag a connection from the Projector node to one or several nodes in your scene. A selective projection connection is represented by a blue dotted line. Once a selective connection is created, the projector only affects the object to which it is connected.

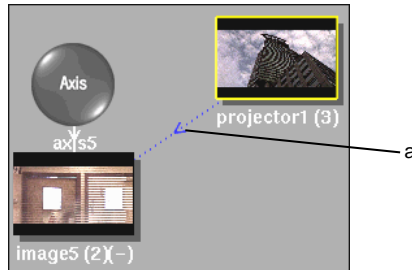

(a) Inclusive projection connection

- To exclude a surface, hold the **Alt** key as you drag a connection from the Projector node to a surface node. The exclusive connection is represented by a red dotted line. Once an exclusive connection is created, the projector ignores the node(s) to which it is connected.

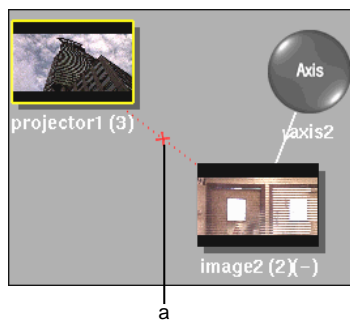

(a) Exclusive projection link

Deforming Models and Surfaces

Use a deformation mesh to deform a 3D model, 3D text, or surface. To use 3D deformations, attach a Deform node to the 3D text, object, or surface, and then use the Deform menu to modify the mesh. You can animate individual points on the deformation mesh, or move the entire mesh over the 3D text or object to apply the deformation as the mesh passes over the object.

Adding a Deformation Mesh

When you add a Deform node, the deformation mesh appears over the 3D text or object. You can view the source mesh, the destination mesh, or both to assist you as you deform the object. You can also turn both meshes off to view only the deformed object.

The deformation mesh consists of cells and lattices. You can divide the mesh into 1-100 lattices and each lattice can be divided by 1-3 cells. Increase the number of cells and lattices to deform specific areas of the object.

To add a deformation mesh:

- 1 In the schematic, select the axis for the image, 3D model, or 3D text.
- 2 Do one of the following:
 - Drag the Deform node from the node bar and place it in the schematic.
 - Drag the Deform node from the node bar and place it where you want it in Result view.
 - Double-click the Deform node in the node bar. You do not need to be in Schematic view to add a node in this manner.

The deformation mesh is added to the selected object.

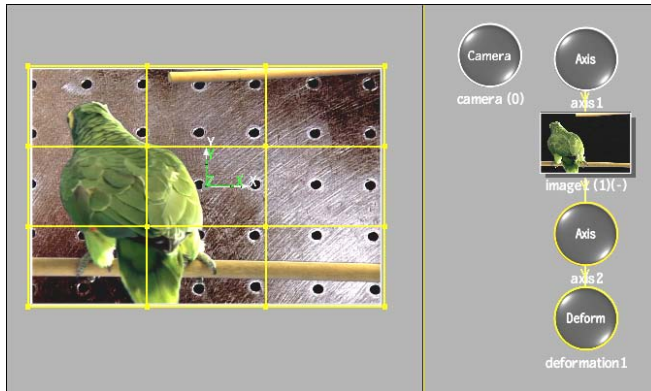
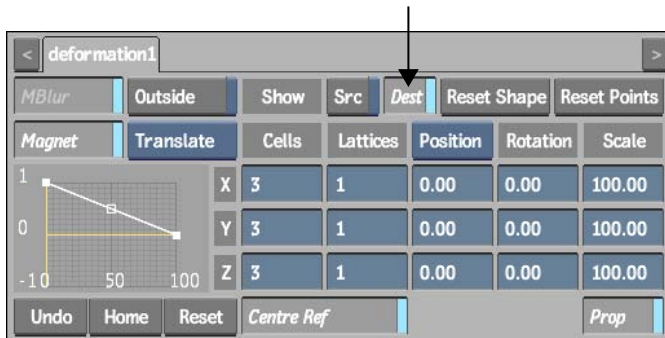

Image courtesy of Quietman

If you do not see the deformation mesh, follow the next steps.

- 3 Double-click the Deform node in the schematic.
The Deform menu appears.
- 4 In the Deform menu, enable Dest to view the deformation mesh in the image window.



Modifying a Deformation Mesh

By default, the deformation mesh has three X,Y, and Z cells and one X, Y, and Z lattice. You can change the number of cells (1-3) or lattices (0-100).

NOTE You can only change the number of cells or lattices before you modify the parameters of the mesh. If you modify a parameter, for example, translate a tangent, you cannot change the number of cells or lattices.

To change the number of cells or lattices:

- 1 In the image window, select the mesh.
- 2 In the Deform menu, change the number of cells in the Cells X, Y, and Z fields. By default they are set to 3, 3, 3.
- 3 In the Lattices X, Y, and Z field, change the number of vertices.
The cells or lattices are added to the deformation mesh.

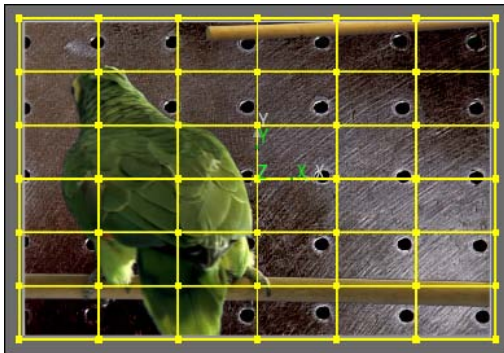

Image courtesy of Quietman

- 4 To view the original mesh, enable Show Source.
- 5 Use the Outside button to apply the deformation outside of the mesh (enabled) or constrain the deformation within the mesh (disabled).

To select points:

- 1 From the Edit Mode box, select Move or Select.
- 2 Select the point(s):
 - To select a single point, click the point.
 - To select multiple points, hold the **Shift** key and click the points you want to select.
 - To select a range of points, hold the **Ctrl** key and draw a box around the points you want to select.

- To add a range of points to a selection, hold **Shift+Ctrl** and draw a box around the points you want to add to the selection.

When you move a point, all selected points also move.

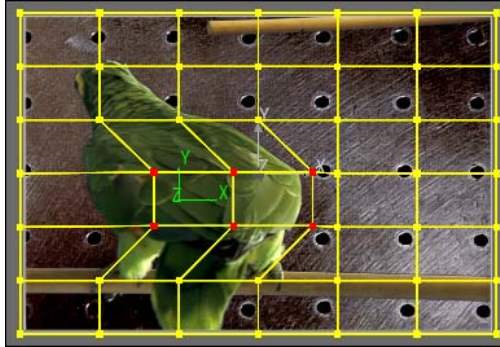

Image courtesy of Quietman

To transform a point on the mesh, drag it in the image window, or change the value in one of the X,Y or Z Translation fields.

Passing a Deformation Mesh Over an Object

Animate the deformation mesh so that it passes over the object. If the Outside button is disabled, the deformation is only applied to the parts of the object within the mesh. To achieve this effect, you must move the mesh over the object. You cannot move the object through the mesh because the object axis parents the mesh axis.

You can also use the channel editor to animate individual or multiple points for the deformation mesh. See [Animation](#) on page 1963.

To pass a deformation mesh over an object:

- 1 Add the deformation mesh to the object.
- 2 In the Deform menu, disable Outside.
- 3 Modify the points on the mesh to achieve the deformation you want.
- 4 In Schematic view, select the deformation axis.
- 5 Click Axis to view the Axis menu.

- 6 Move the deformation mesh so that it is on one side of the object.
- 7 Set a new keyframe with the deformation mesh on the other side of the object.

Transforming a Range of Points

Use the magnet to transform a range of deform mesh surface points. In the Deform Mesh menu, the magnet controls include the Magnet button, the Magnet Transformation box, and the Magnet Curve Editor. The magnet controls work the same way as the magnet controls in the Extended Bicubic menu. See [Transforming Multiple Points](#) on page 2193.

Creating 3D Text

You create 3D text using the 3D Text menu in Action. 3D text strings have the same properties as 3D imported objects. In addition, with 3D text, you specify typical text properties such as font, font size, kerning, and italics. In 3D space, text has depth and can be rotated on the X, Y, or Z axis.

You can create 3D text strings using Type 1, TrueType, or Asian fonts. You set 3D text properties using the 3D Text Editor. To access the 3D Text Editor, add a 3D Text node to your scene, and double-click the 3D Text node in the schematic.

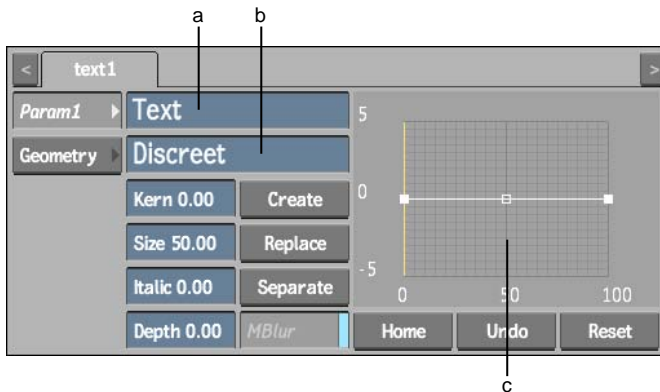

(a) Text field (b) Font field (c) Bevel curve

The 3D Text Editor controls are described as follows.

Text field Displays the characters that make up the text string.

When keyboard preference is enabled, clicking this field displays the on-screen keyboard representing the character set for the selected font. Enable Up ASCII to access the rest of the character set.

Font field Displays the font library, where you select a font for the text string. You can select from Standard, TrueType, and Asian fonts.

By default, Action uses the font specified for the `TextDefaultFont` token in the `init.cfg` configuration file. For example: **TextDefaultFontTimes-Roman**

Kern field Sets kerning for the characters in the text string.

Size field Specifies font size for the characters in the text string.

Italic field Italicizes the characters in the text string.

Depth field Extrudes the characters in the text string, making it three dimensional.

Create button Places the contents of the Text field in the scene.

Replace button Applies changes to the 3D text string.

Separate button Separate text so that each letter has its own axis. See [Separating Text](#) on page 2305.

MBlur button Enables or disables a motion blur only for the 3D text. See [3D Text Selective Motion Blur](#) on page 2303.

Bevel curve Applies a bevel to the depth of the text string when you manipulate the Bevel curve. You can move and add points to the curve, as well as adjust the tangent handles to produce different effects with the text string. See [Creating Bevelled Text](#) on page 2303.

Home button Resets the Bevel curve viewer to show the whole curve.

Undo button Undoes Bevel curve operations.

Reset button Resets the Bevel curve.

Click the Geometry tab to access the Geometry menu to apply any of the geometry settings to your 3D text. See [Working with 3D Geometry](#) on page 2278 for definitions of the specific Geometry controls.



To create 3D text:

- 1 Do one of the following:
 - Drag the 3D Text node from the node bar and place it in the schematic.
 - Drag the 3D Text node from the node bar and place it where you want it in Result view.
 - Double-click the 3D Text node. You do not need to be in Schematic view to add a node in this manner.

A Geometry object, with its parent axis, appears in the schematic.

- 2 Double-click the 3D Text node in the schematic, or follow the tab population rules for the Object menu. See [Selecting Objects and Populating Menu Tabs](#) on page 2102.

The Text menu appears.

- 3 Enter a text string in the Text field.
- 4 To change the font, click the Font field and select a new font from the font library.
- 5 Set font size, kerning, italics, and depth in the corresponding fields.
- 6 Click Create.

The 3D text string appears in the scene

To enter Unicode values when creating 3D text objects:

- 1 Click the 3D Text Input field to display the on-screen keyboard.
- 2 Make sure Num Lock is on to activate the numeric keypad on your keyboard.
- 3 Hold down the **Alt** key.

- Without releasing the **Alt** key, enter the Unicode value that corresponds to the character you want to add, and then press **Enter**.

TIP To enter more characters using their Unicode values, keep the **Alt** key pressed. Press **Enter** after each unicode value to enter multiple characters using this technique.

- Release the **Alt** key and press **Enter** to create the 3D text object.

3D Text Selective Motion Blur

When you enable Motion Blur in the Action Setup menu, motion blur processing is enabled for all objects. You can selectively disable motion blur on an object-by-object basis. To disable motion blur for a 3D text object, disable the MBlur button in the 3D Text menu (the 3D text object must be selected).

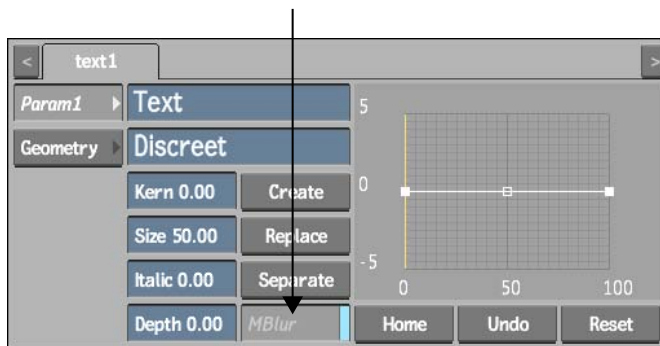

NOTE If Motion Blur is not enabled in the Setup menu, all MBlur buttons are inactive.

Creating Bevelled Text

Use the Bevel curve to add a bevelled edge to your 3D text. Use the options in the Edit Mode box to add, select, delete, or move keyframes on the Bevel curve. The Bevel curve behaves in much the same way as an animation curve in the Channel Editor.

Experiment with different curves to create different effects.

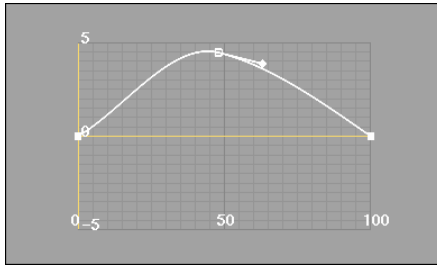

Bevel curve



Resulting bevelled text

You can save Bevel curve settings as well as font, character size, kerning, italics, and depth. See [Saving, Loading, and Importing](#) on page 2126.

Animating 3D Text

With 3D text strings, you animate the 3D text channels and geometry channels in the Channel Editor. However, neither the text string nor its Bevel curve can be animated. The 3D text channels are contained in the text folder as shown in the following figure. See [Animation](#) on page 1963.

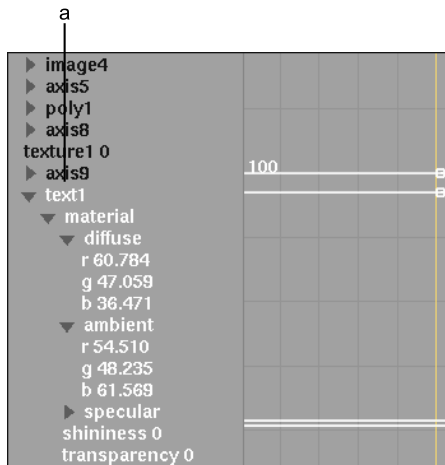

(a) The default name. If you rename the Geometry node for the 3D text, its new name appears here.

You can also create a 3D text deformation effect by applying a Deform mesh to the 3D text string.

Separating Text

Rather than create a separate axis for each letter you type, you can separate words or sentences created in the Text menu so that each letter can be individually manipulated.

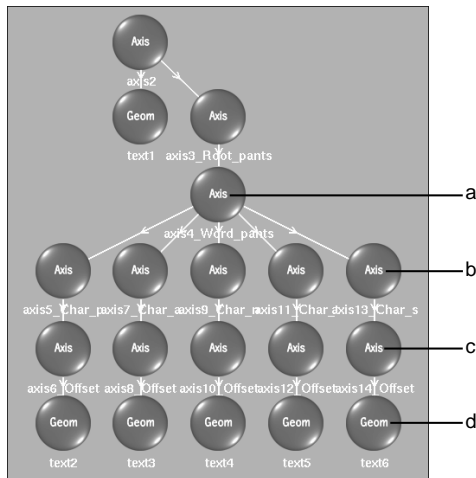

(a) Root axis for word (b) Root axis for letter (c) Offset per letter (d) Letter geometry

To separate text:

- 1 Create text as described in [Creating 3D Text](#) on page 2300.
- 2 Select the text to separate.
- 3 From the 3D Text menu, click Separate.

Each letter of the text geometry is given its own axis and offset (to separate the letters). Each letter is now its own independent geometric object. Words are also given their own axis.

Using Garbage Masks as 3D Geometry

Garbage mask files are created through the Keyer or by the GMask node in Batch. You can import a saved garbage mask setup into Action, and specify

3D properties, such as depth and geometry settings. Softness and offset settings in the imported garbage mask are not brought into Action. Any holes in the imported garbage mask are also holes in the 3D geometry. If your garbage mask is animated, only the first shape is imported into Action. For help creating garbage masks, see [Drawing a Mask](#) on page 1717.

TIP A library of preset garbage mask setups is available. To load a preset garbage mask, navigate to the `/usr/discreet/<product home>/gmask` directory when importing your 3D model.

Once you import a garbage mask as a 3D geometry into Action, use the GMask menu to extrude the garbage mask.

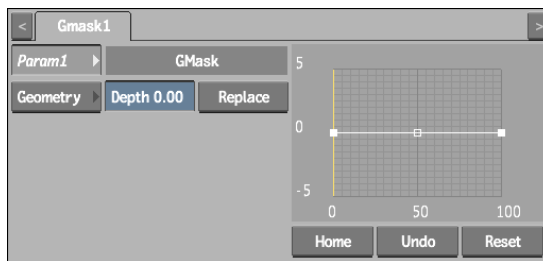

Depth field Extrudes the garbage mask, making it three dimensional. Use the depth setting in conjunction with the Axis controls to manipulate the garbage mask.

Replace button Applies changes to the garbage mask geometry.

Bevel curve Adds a bevelled edge to your garbage mask geometry. Use the options in the Edit Mode box to add, select, delete, or move keyframes on the Bevel curve. The Bevel curve behaves in much the same way as an animation curve in the Channel Editor.

Home button Resets the Bevel curve viewer to show the whole curve.

Undo button Undoes Bevel curve operations.

Reset button Resets the Bevel curve.

Click the Geometry tab to access the Geometry menu to apply any of the geometry settings to your garbage mask. See [Working with 3D Geometry](#) on page 2278 for definitions of the specific Geometry controls.

Topics in this chapter:

- [About Lights](#) on page 2307
- [Adding a Light Source](#) on page 2308
- [Applying Selective Lighting](#) on page 2311
- [Modifying Surface Lighting](#) on page 2313

About Lights

Objects are lit up in the scene according to the number, position, direction, and colour of light sources, as well as the rotation and spread of each light source.

You can add any number of light sources to a scene. You can also control each light individually. By default, the light you add to the scene is applied to all surfaces. However, you can also apply a light source to specific surfaces.

Lights Workflow

The following table shows the recommended workflow when working with lights in the Action module.

Step:	Refer to:
1. Add a light.	Adding a Light Source on page 2308.

Step:	Refer to:
2. Modify light attributes.	Modifying Surface Lighting on page 2313.
3. Light specific objects.	Applying Selective Lighting on page 2311.

Adding a Light Source

When you add a light to a scene, it is applied to all objects. There is no limit to the number of lights you can add. Before adding another light, you may want to position the light and modify its attributes. In the Lights menu, you can set lighting properties such as position, orientation, spread, falloff, and colour.

To add a light to the scene:

- 1 Do one of the following:
 - Drag the light node from the node bar and place it in the schematic.
 - Drag the light node from the node bar to Result view, so you can see its effect on the scene before placing it exactly where you want.
 - Double-click the light node in the node bar. The node appears next to the last added object. You do not need to be in Schematic view to add a node in this manner.

A light is added to the scene. An icon representing the light source is added to the schematic.

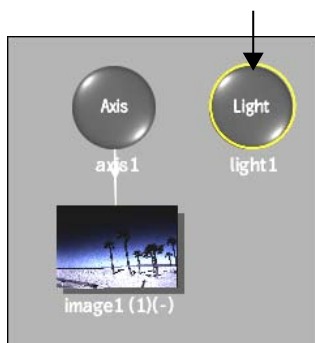

Unlike many objects, a light is added without an axis. To set the position and rotation of a light source, use the Position and Rotation fields in the Light menu.

- 2 To display the Light menu, double-click the selected light in the schematic, or follow the tab population rules for the Object menu. See [Selecting Objects and Populating Menu Tabs](#) on page 2102.

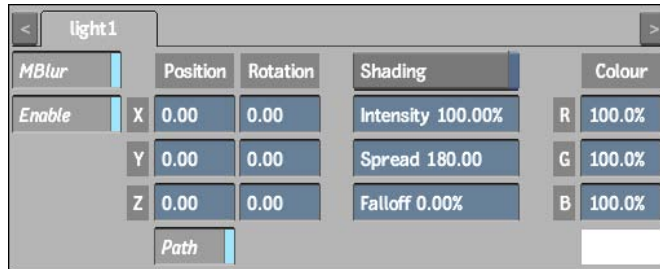

The Light controls are described as follows.

MBlur button Enables or disables motion blur only for the light.

Enable button Turns the selected light source on or off.

Motion Path button Animates the position of the light using a spline drawn in the scene. Disable Motion Path to animate the position of a light using explicit animation.

Position X, Y, and Z fields Place the light source in the scene.

Rotation X, Y, and Z fields Rotate the light source.

Shading button Enable to light up the scene using added light sources. When Shading is disabled, no lighting effects appear in the scene; surface and 3D models appear flat. This same button appears in the Rendering section of the Action Setup menu.

Intensity field Adjusts the intensity of the light.

Spread field Uses a light source as either a point light or a spotlight. A point light radiates light uniformly in all directions. A spotlight radiates

a cone of light centred along the spotlight direction. Use the Spread field to change the spread angle. A spread of 90 or less creates a spotlight.

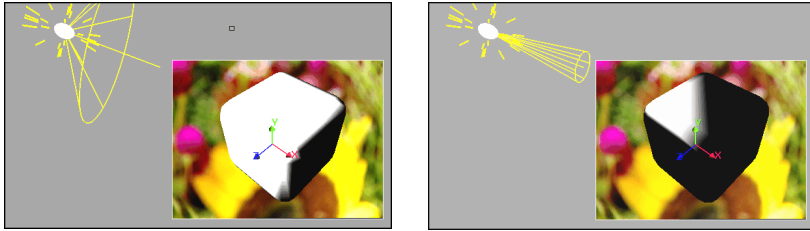

Falloff field Adjusts the amount of falloff around the edge of the light source. This value also changes the size of the specular highlight. A lower falloff value creates a larger specular highlight.

RGB fields and Colour pot Changes the colour of the light source by entering values in the red, green, and blue channel fields or using the colour picker.

- 3 Click Enable to activate the light source.
The light icon appears in the scene.

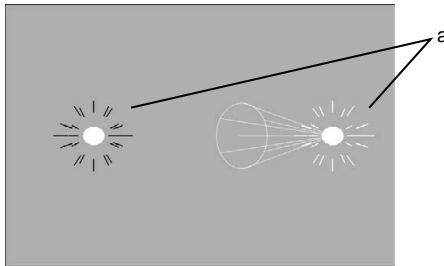

(a) Light sources in the scene.

All light sources initially appear at the same X, Y, and Z position in the scene (0, 0, 0). If you add two light sources, for example, you need to move one light source in order to see the other.

Selecting a Light Source

You can select a light source in the following ways:

- Click the light source in the scene.

- In Schematic view, click the icon corresponding to the light source.
- Select a Light folder in the Channel Editor.
- Use the Prev and Next buttons to select the previous or next light source.

Importing Lights

You can import 3D data saved in the Alias FBX format. FBX support allows you to import lights and their data. See [Importing the FBX Format](#) on page 2277.

Applying Selective Lighting

When you add a light source to a scene, the light is applied to all surfaces. You may want a light source to only illuminate an individual or specific group of surfaces, or prevent a light source from illuminating an individual or specific group of surfaces.

To apply selective lighting:

- 1 Add multiple surfaces to the scene. See [Adding Surfaces](#) on page 2178.
- 2 Add a light to the scene.
All surfaces are illuminated.

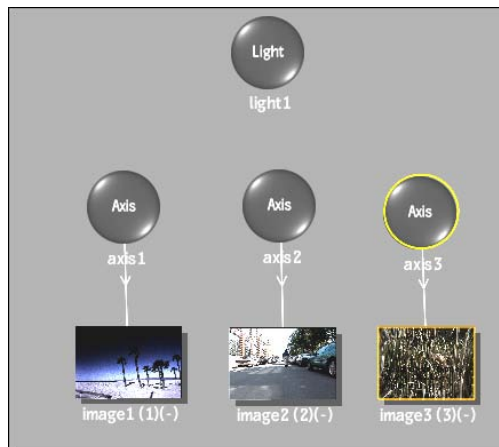

- 3 Select Lighting from the Edit Mode box.

- 4 To illuminate only a selected surface, click the light node, and drag it to an axis or image you want illuminated.

The selected object is connected to the light source by a blue dotted line with an arrow, and only the selected surfaces are illuminated.

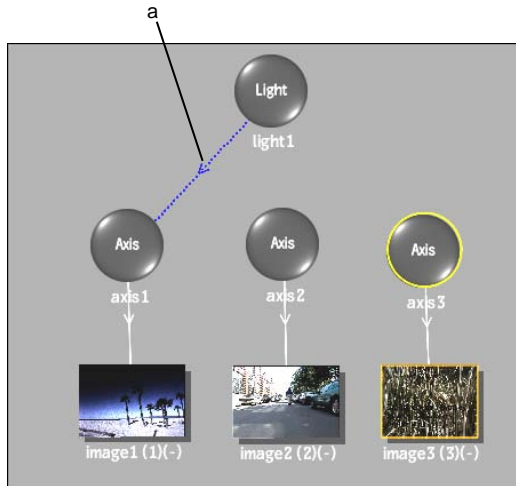

(a) Light inclusion link

- 5 To exclude a surface, hold the **Alt** key while clicking and dragging from the light source to the surface you do not want illuminated.

Excluded surfaces are connected to the light source by a red dotted line with an "X", and they are not illuminated. In the following example, all surfaces are illuminated, except for image3, which is excluded.

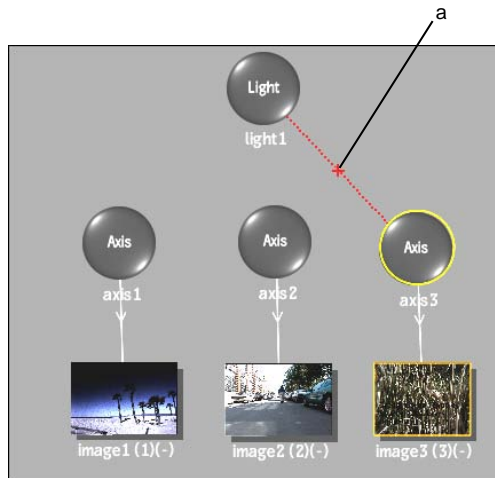

(a) Light exclusion link

NOTE To remove the inclusion or exclusion link, click and drag over the line that connects the light source to the axis or image.

Modifying Surface Lighting

After you set the parent-to-child relationships between lights and surfaces, you can set specific surface lighting properties. You control a surface's lighting and adjust the surface's specular highlight in the Surface menu. To access the Surface menu, double-click the selected surface in the schematic, or follow the tab population rules for the Object menu (see [Selecting Objects and Populating Menu Tabs](#) on page 2102).

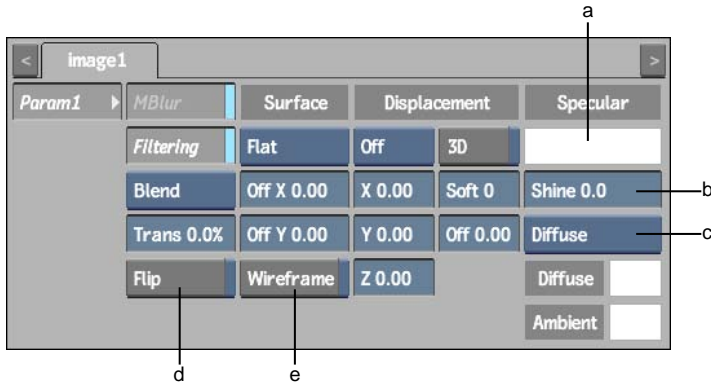

(a) Specular Highlight colour box (b) Shine field (c) Lighting box (d) Flip button (e) Wireframe button

The Surface controls that relate to lights are described as follows.

MBlur button Excludes the selected object from the global motion blur effect. See [Blurring a Single Object](#) on page 2237.

Specular Highlight colour box Change the specular colour. Click the colour pot and use the colour picker to pick specular colour.

The specular highlight is visible only if Shading is enabled in the Setup menu and if shine is greater than 0. See [Adjusting Specular Highlights](#) on page 2314.

Shine field Change the intensity of the specular highlight. See [Adjusting Specular Highlights](#) on page 2314.

Lighting box Applies diffuse or ambient lighting to a surface. See [Applying Incidental Light Reflection](#) on page 2316.

Flip button Flips the normals of the surface so that light is applied to the opposite side of the surface. See [Flipping a Surface's Normals](#) on page 2318.

Wireframe button You can remove some lighting effects for a selected surface by converting surfaces to a wireframe depiction of the surface. See [Converting to Wireframe](#) on page 2317.

Adjusting Specular Highlights

A specular highlight is a reflection of a light source. The position of the specular highlight depends on the position and number of light sources surrounding a surface and the angle of the camera.

Use the Shine field to change the intensity of the specular highlight. When the Shine value is set to 0, the specular highlight is disabled. To change the size of the specular highlight, use the Falloff field in the Light menu.

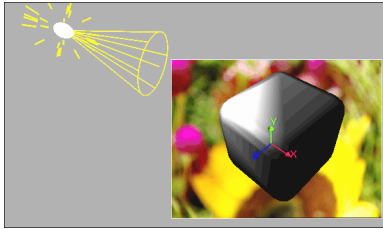

This surface is lit using a Falloff of 30 and a Spread of 27. The surface's Shine is set to 10.

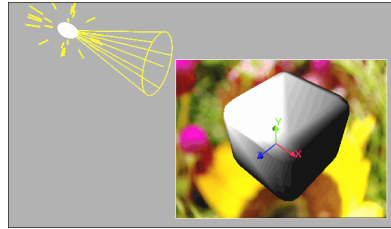

This surface is lit using a Falloff of 20 and a Spread of 27. The surface's Shine is set to 1.

By default, the specular highlight is the same colour as the light source. You can change the colour of the specular highlight by changing the specular colour values.

The specular colour is the colour of light that is reflected by the surface. For example, if the specular colour is red and the light source is white, the specular highlight is red. If the specular colour is yellow and the light source is red, the highlight is orange.

To adjust specular highlights:

- 1 Add and position a light source in the scene.
- 2 In the Light menu or the Rendering section of the Action Setup menu, enable Shading.

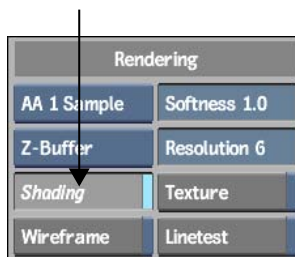

- 3 In the Surface menu, use the Specular Highlight fields to set the specular colour.

- 4 Set a value in the Shine field. A small Shine value produces an intense highlight while a large Shine value produces a dim highlight.

Applying Incidental Light Reflection

Set how a surface reflects incidental light by applying ambient or diffuse lighting. The actual colour of the reflection depends on both the colour value of each pixel and the colour of the incidental light. The intensity of the reflection depends on the orientation of the light source relative to the surface; it is greatest where the incident light strikes the object perpendicular to its surface. The intensity of the reflection is independent of the camera eye position.

When you turn shading on, you do not have to enable a light source to see the lighting effect, as a default infinite light source supplies ambient light at 20% intensity. The infinite light source is located behind the camera eye and cannot be moved. As soon as you add a light source, the infinite light source is replaced by the new light source.

To apply incidental light reflection:

- 1 In the Rendering section of the Action Setup menu, enable Shading and disable Texture.

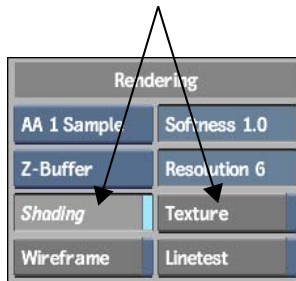

- 2 In the scene, select the surface to receive incidental light reflection.
- 3 In the Surface menu, make a selection from the Lighting box.



Select: **To reflect incidental light:**

Ambient To all parts of a surface that are not directly illuminated.

Diffuse Equally in all directions, producing a flat reflection on the object.

- 4 Optional: Adjust the colour of the incidental light using the ambient or diffuse RGB channels.

To display the RGB channels, click Animation to display the Channel Editor. Expand the surface's folder (it should already be selected), expand its Material folder, then expand the Ambient or Diffuse folder.

Converting to Wireframe

You can remove some lighting effects for a selected surface by converting surfaces to a wireframe depiction of the surface. When Wireframe is enabled, specular values and any applied textures are replaced with a wireframe view of the surface. When used on an image, the surface will adopt a screen-like look.

To convert to wireframe:

- 1 In the scene, select the surface to convert to wireframe.
- 2 In the Surface menu, enable Wireframe.



The selected surface becomes a wireframe surface.

Flipping a Surface's Normals

When you flip a surface's normals, light is applied to the opposite side of a surface. Use this feature to create a two-sided shaded surface.

To create a two-sided surface:

- 1 Add a surface and a light source.
- 2 In the Light menu or the Rendering section of the Action Setup menu, enable Shading.

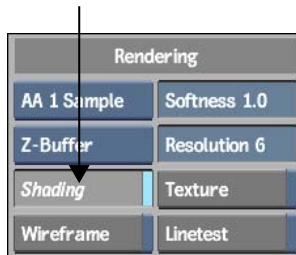

- 3 Copy the surface and its axis using the branch option in Schematic view. See [Copying Objects](#) on page 2114.
- 4 Select the surface of the copied branch.
- 5 In the Surface menu, enable Flip.

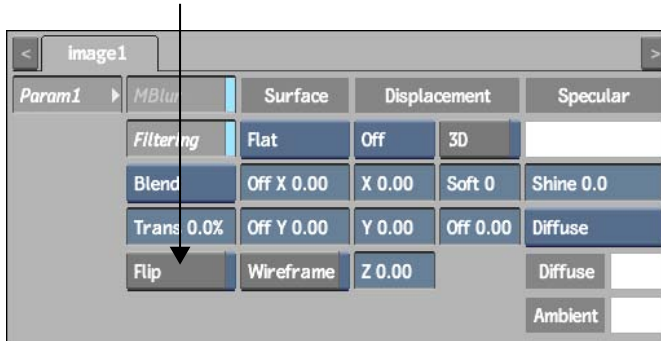

To control both surfaces, parent them by a new axis and use this axis to rotate, scale, shear, and move the two surfaces. There may be a priority problem causing one surface to be drawn over the other. To correct this problem, use the Priority Editor to animate the drawing priority of surfaces or change the Z position of one surface by one pixel. See [Reordering Surfaces](#) on page 2204.

Action: The Particle System

79

Topics in this chapter:

- [About Action's Particle System](#) on page 2321
- [Generating Particles](#) on page 2324
- [Customizing the Particle Stream](#) on page 2328
- [Exploding Objects and Surfaces](#) on page 2340
- [Manipulating Particles](#) on page 2343
- [Bouncing Particles](#) on page 2362
- [Combining Particle Streams](#) on page 2366
- [Sample Particle Setups](#) on page 2368

About Action's Particle System

Use Action's 3D particle system to create a variety of effects such as snow, rain, fog, and tornadoes, as well as fireworks, sparks, and explosions.

Particles are 3D objects that originate from a surface, light, or 3D object. Particles can be spheres, cones, squares, points, lines, or any image, 3D text, or 3D object. Particles are generated in the direction of the normals of a surface, light, or 3D object—a normal is a line perpendicular to the surface of an object.

In Action, the main components for generating particles are generators, manipulators, and bouncers. You can also use the particle system to explode a 3D object or an image.

NOTE Rendering particles is faster if Z-Buffer On is selected in the Rendering section of the Action Setup menu.

Particles Workflow

The following table shows a possible workflow when working with particles in the Action module.

Step:	Refer to:
1. Add a particle generator.	Generating Particles on page 2324.
2. Add a particle manipulator.	Manipulating Particles on page 2343.
3. Set the particle path.	Forming a Particle Path on page 2353.
4. Add bouncers.	Bouncing Particles on page 2362.
5. Modify the particle stream.	Setting Stream Properties on page 2329.
6. Apply texture to particles.	Applying Textures to Particles on page 2339.
7. Add gravity.	Simulating Gravity on page 2348.
8. Render particles.	Setting Particle Rendering Properties on page 2332.

Generators

To create a particle stream, start by adding a particle generator that creates a stream of particles when attached to a light source, 3D object, or surface. You can use three different generators: light source, surface, and 3D object.

Particle generators have two settings:

- The Generate setting creates a stream of particles using the shape of a surface, a 3D object, or the spread of a light source. See [Generating Particles](#) on page 2324.

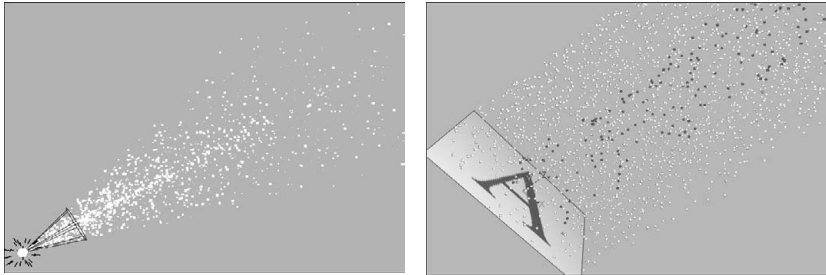

- The Explode setting breaks up a surface or 3D object. See [Exploding Objects and Surfaces](#) on page 2340.

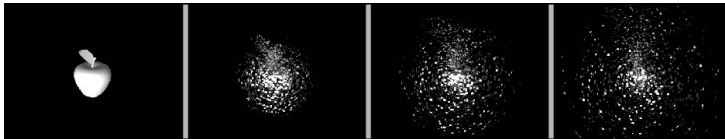

Manipulators

Particle manipulators are used to influence either the position or the speed of particles. Manipulators can simulate the effects of a vortex, gravitational pull, or the pull toward a point, line, or plane. Manipulators are parented by the particle stream that they influence.

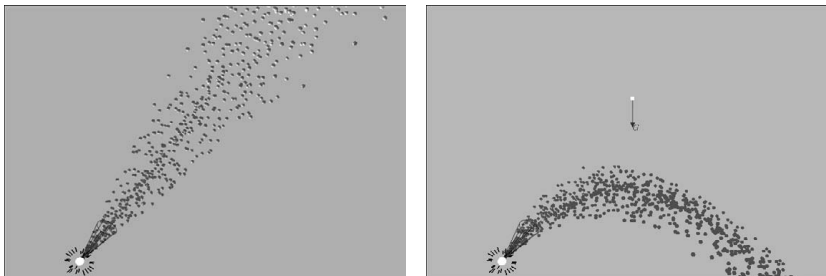

Action offers eight manipulators. Instructions on how to use each manipulator are provided in [Manipulating Particles](#) on page 2343.

Bouncers

Particle bouncers are used to influence the behaviour of particles when they come into contact with a surface. You can parent an axis or light source to a particle bouncer. See [Bouncing Particles](#) on page 2362.

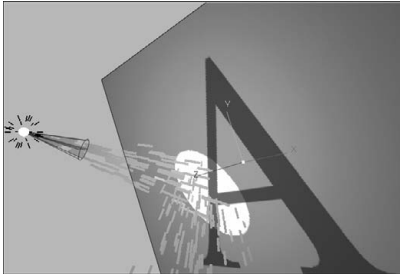

Particle Setup Compatibility

Action setups created in a pre-9.0 version of Flame that use a Variation value for Number, LifeTime, Speed, and TrailSize can be restored in the current version, but will render slightly differently.

Generating Particles

You can create a particle stream that behaves in different ways depending on the type of generator you use. When creating a particle stream, you can use three different generators: light source, surface, and 3D object.

Use as a Generator:	To:
light source	Create a stream of particles starting from a single point.
surface	Generate particles based on the area, shape, and colour of a surface.
3D object	Generate particles from the centre of each polygon.

Using a Light Source

When a particle generator is attached to a light source, it uses the position and rotation of the light source to move and rotate the particle generator.

To add a particle stream using a light source:

- 1 Add a Light node to your scene.
- 2 Double-click the new light in the schematic, or follow the tab population rules for the Object menu (see [Selecting Objects and Populating Menu Tabs](#) on page 2102).
- 3 Adjust the spread and position of the light source in the Light menu. Use the Spread field to set the spread of the particle stream. The Intensity, Falloff, and Colour fields are not used by the particle generator.

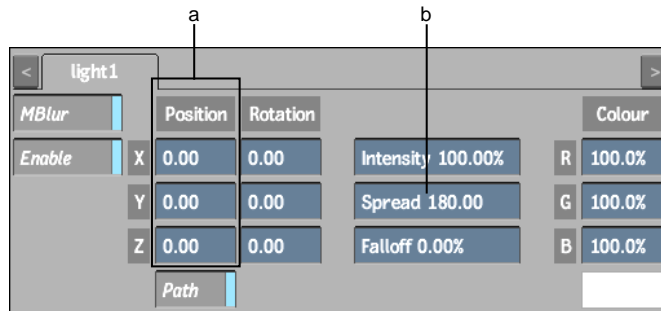

(a) Position fields (b) Spread field

- 4 With the light node selected in the schematic, do one of the following:
 - Drag the particle generator node from the node bar and place it in the schematic.
 - Double-click the particle generator node. You do not need to be in Schematic view to add a node in this manner.

A particle generator object is added and automatically connected to the selected light source.

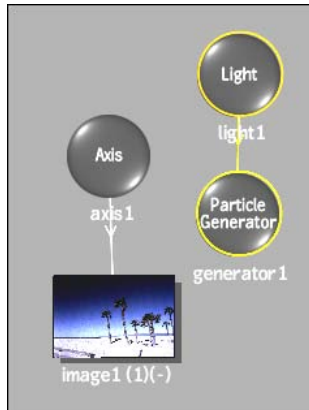

- 5 Set the particle generator's properties. See [Customizing the Particle Stream](#) on page 2328.
- 6 If you do not want the light source to illuminate the scene, deactivate the light by clicking the Enable button in the Light menu. When Enable is deactivated, the light source is used as a particle generator only.

With a light source, you can animate the position of the particle stream by moving the light, changing the spread, and rotating the light. Because the generator is a light source, you can animate the position of the particle generator using a motion path.

Using a Surface

Use a surface as a particle generator to generate particles based on the area, shape, and colour of a surface. You can use a surface's matte to restrict where particles are generated. When the matte is off, the particle stream is generated from the entire surface. When the matte is on, particles are only generated where the matte is white or grey.

You can animate the shape of the surface using its tangent handles. The starting area of the particle stream matches the surface's shape animation. See [Changing the Shape of a Surface](#) on page 2183.

To add a particle stream using a surface:

- 1 Select or add a surface that you want to use as a particle generator.

- 2 Adjust the surface's shape, position, and other attributes. See [Modifying Surfaces](#) on page 2179.
- 3 With the surface node selected in the schematic, do one of the following:
 - Drag the particle generator node from the node bar and place it in the schematic.
 - Double-click the particle generator node. You do not need to be in Schematic view to add a node in this manner.

A particle generator object is added and automatically connected to the selected surface.



- 4 Set the particle generator's properties. See [Customizing the Particle Stream](#) on page 2328.
- 5 If you do not want the surface to appear in the scene, you can hide the surface in Schematic view. A particle stream is generated from the hidden surface.
- 6 To make the generated particles change as the surface's clip changes, enable Indirect in the Particle Generator menu.

Using a 3D Object

You can use a 3D object as a particle generator. Particles are generated from the centre of each polygon.

To add a particle stream using a 3D object:

- 1 Select or add the 3D object that you want to use as a particle generator.
- 2 With the 3D object node selected in the schematic, do one of the following:
 - Drag the particle generator node from the node bar and place it in the schematic.
 - Drag the particle generator node from the node bar to Result view, so you can see its effect on the scene before placing it exactly where you want.
 - Double-click the particle generator node in the node bar. You do not need to be in Schematic view to add a node in this manner.

A particle generator object is added and automatically connected to the selected 3D object.

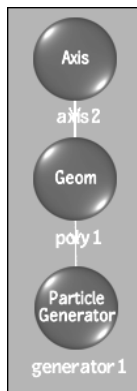

- 3 Set the particle generator's properties. See [Customizing the Particle Stream](#) on page 2328.
- 4 If you do not want the 3D object to appear in the scene, hide the model in Schematic view. A particle stream is generated from the hidden model.

Customizing the Particle Stream

Whether you use a light source, 3D object, or surface, the particle stream uses the same properties, allowing you to create custom particles and apply textures to particles. To access these properties, double-click the particle generator in

the schematic, or follow the tab population rules for the Object menu. See [Selecting Objects and Populating Menu Tabs](#) on page 2102.

Setting Stream Properties

The following properties in the Particle Generator Param1 menu affect the particle stream.

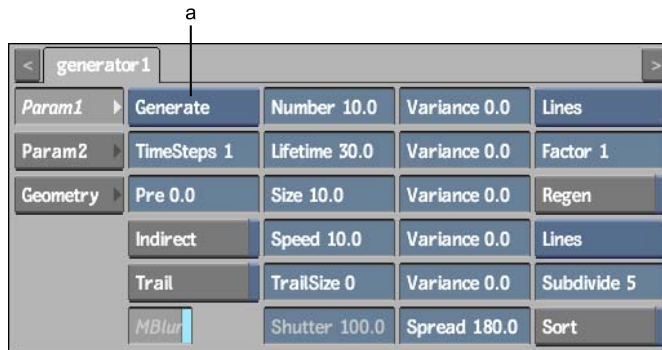

(a) Stream Type box

Stream Type box Displays the particle generator's stream types: Generate or Explode.

Timesteps field Improves the accuracy of the particle stream. By default, Timestep is set to 1, which means that time simulation is once per frame.

When Timestep is set to 2, the position of each particle is calculated once between frames. Any change in speed or position caused by manipulators or bouncers is applied between frames. When Timestep is set to 3, the position of each particle is calculated twice between frames. The greater the timestep value, the longer it takes to process.

Typically, you use Timestep with a particle manipulator or bouncer on a particle stream. In the following example, the same particle settings and manipulator (AccPoint) are used. Only the timestep values are different. The particle stream on the left uses a timestep of 1 while the stream on the right uses a timestep of 6.

In the following figure, notice the particle stream on the right is more accurate.

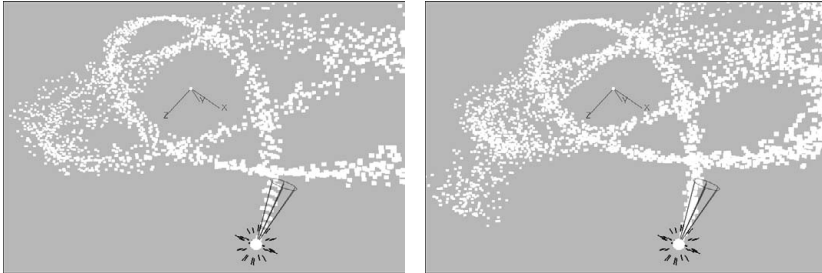

Pre field Sets the start point of the particle stream. With a value of 0.0, the particle stream starts creating particles at frame 1. With a value of 100, the clip begins as if the particle stream has been generating for 99 frames.

Indirect button Use the Indirect button only when the particle generator is a surface.

When Indirect is enabled, the part of the surface used by the particle changes with each frame. For example, if the media applied to the surface changes from red to blue over 10 frames, each particle changes from red to blue as the surface changes.

When Indirect is disabled, the part of the surface used by the particle is locked to the frame where the particle was generated. For example, if the media applied to the surface changes from red to blue over 10 frames and a particle is generated at the first frame, when the surface was red, the particle stays red.

Trail button When enabled, draws each particle with a trail. The length of the trail is shown in the TrailSize field.

MBlur button Enables or disables motion blur for particles emitted from the selected Generator.

Shutter field Defines the length of the tail for lines, cones, and quads. Shutter is expressed as a percentage. At 100%, the tail's length is the same as the head (Size field). At 400%, the tail's length is four times the size of the head.

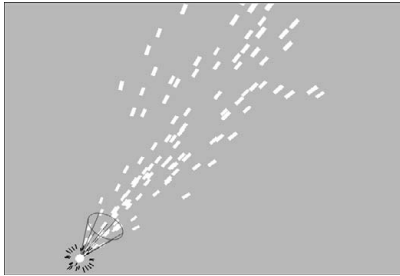

Shutter at 100%

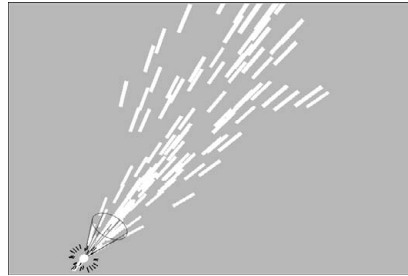

Shutter at 400%

Spread field Sets the spread for the second particle generator when two particle generators are parented. When the first particle stream dies, the second particle stream begins. See [Combining Particle Streams](#) on page 2366.

This also sets the spread of a particle stream that bounces off surfaces. See [Bouncing Particles](#) on page 2362.

Setting Particle Properties

In the middle of the Generator Param1 menu, a table lists the different particle generation properties.

a

generator 1				
Param1	Generate	Number 10.0	Variance 0.0	Lines
Param2	TimeSteps 1	Lifetime 30.0	Variance 0.0	Factor 1
Geometry	Pre 0.0	Size 10.0	Variance 0.0	Regen
	Indirect	Speed 10.0	Variance 0.0	Lines
	Trail	TrailSize 0	Variance 0.0	Subdivide 5
	MBIur	Shutter 100.0	Spread 180.0	Sort

(a) Particle generation properties

Number field Displays the number of particles generated per frame. If you specify a number less than 1 (from 0.1 to 0.9), particles are generated randomly.

For example, if you set the number to 0.1, a particle is generated every 10 frames. The exact frame within those 10 frames when the particle is generated is randomly selected. If you set the number of particles to 0.3, a particle is randomly generated approximately every three frames.

Lifetime field Displays the number of frames each particle lasts. For example, if Lifetime is 20 frames, a particle generated at frame 15 disappears at frame 35.

Size field Displays the size of each particle in pixels. This parameter only affects cones, spheres, quads, squares, and objects.

Speed field Displays the speed of each particle in pixels per frame.

TrailSize field Displays the length of each particle's trail in particles. A particle trail only appears when the Trail button is enabled.

Varying Each Parameter

Each parameter has a variance value used to specify how much the parameter varies each time particles are generated. Exactly what gets varied depends on the parameter.

For example, if you set the Number parameter to 10 and its Variance parameter to 5, the number of particles generated at each frame is randomly selected between 5 and 15.

The unit of measurement used by each Variance field matches the parameter it is varying. For example, if the Number parameter is expressed in particles per frame, so is its Variance field. The Speed parameter is in pixels per frame and so is its Variance field.

Setting Particle Rendering Properties

The following Generator properties affect the rendering and previewing of the particle stream.

NOTE Rendering particles is faster if Z-Buffer On is selected in the Rendering Section of the Action Setup menu.



(a) Interactive Type box (b) Render Type box

Interactive Type box Specifies the type of particle to display in the Action scene. For example, as you move between frames, the particle stream is redrawn. If you are using a custom 3D object for each particle, redrawing the scene may take a while. By changing the interactive type to a point or line, your interaction with Action is much quicker.

Factor field Speeds up Action by changing the number of particles shown in the scene. This works only while using Action and does not affect the rendered result.

For example, if you generate 1000 particles with manipulators and bouncers, interacting with Action may become slow because calculations have to be made for each particle. If you specify a factor of 10, the number of particles is reduced to 10%, or 100 particles. Using Action is then faster, yet when you click Preview or Process, 1000 particles are created.

Regen button When enabled, automatically updates the scene when you change a particle generator parameter. Using Action with this button enabled may cause slowdowns since the particle stream is recalculated each time a parameter is changed.

Render Type box Specifies the type of particle used when rendering the scene.

Select:	To:
Node	Use your own 3D object, text, or a surface for each particle. See Using Custom Particles on page 2336.
Cones	Use a cone for each particle. You can adjust the size of the cone's tail.

Select:	To:
Spheres	Use a 3D object of a sphere for each particle.
Polygons	Explode 3D objects and surfaces. See Exploding Objects and Surfaces on page 2340.
Quads	Use a square with a tail for each particle. You can adjust the size of the square's tail.
Squares	Use a square for each particle.
Lines	Use a line for each particle.
Points	Use a single pixel for each particle. Points are not affected by size or trail.

Subdivide field Sets the number of polygons used to render cones and spheres. The larger the number of subdivisions, the smoother the cones or spheres are drawn. Increasing Subdivide also increases rendering time.

If you are using an imported 3D object or text for a particle, use the Subdivide field and button in the Geometry menu to set the number of polygons. The Geometry menu's Subdivide field works differently than the Subdivide field in the Generator menu. See [Subdividing a Model](#) on page 2282.

Sort button Determines how the particles are drawn, according to the Z-order. If a Particle Generator node is selected, the state of the Sort button is the same in the Param1 and Geometry menus.

Setting Additional Generator Properties

Additional particle generator controls can be found in the Param2 tab.

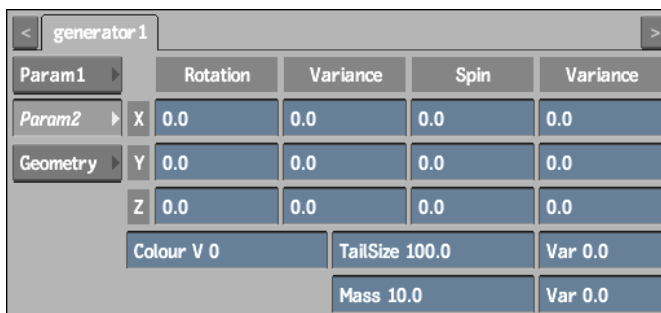

Rotation fields Sets the orientation for particles that have just been born (spawned).

Rotation Variance fields Varies the rotation of a particle once spawned from the particle generator.

Spin fields Acts as a speed setting to a rotation animated over time. For example, a value of 30 causes a particle to spin 30 degrees per frame around its axis.

Spin Variance fields Adds a variation to the Spin channel once particles are spawned from the particle generator.

Colour V field Varies the colour of each particle based on the colour set in the Diffuse colour bar (Particle Geometry menu). The variance is expressed as a percentage. Colour Variance works with surfaces or geometries.

TailSize field Sets the width of a particle's tail. TailSize is expressed as a percentage:

- At 100%, the tail is the same width as the head.
- At 200%, the tail is twice as wide as the head.

TailSize only works with quad and cone particle types.

TailSize Variance field Varies the TailSize value as a percentage.

Mass field Sets and animates the mass of each particle. Mass is used with damping when manipulating particles. See [Setting Manipulator Properties](#) on page 2344.

Mass Variance field Varies the mass as a percentage.

Setting Geometry Properties

You can use the Particle Geometry menu controls to add colour, specular highlight, shine, and transparency to all particles. To access this menu, click the Geometry tab in the Generator menu.

Use the available particle geometry controls to affect the particle stream, whether it is a surface or a geometry. The controls behave in the same manner as when using with the Geometry menu for a 3D model. See [Working with 3D Geometry](#) on page 2278.

Setting Channel Editor Properties

The Channel Editor includes the particle properties included in the Particle menus for which you can set values and create particle animation effects. You set these properties in conjunction with those located in the Particle Generator, Particle Manipulator, and Particle Bouncer menus.

You must first add a particle generator, a particle manipulator, or a particle bouncer to the scene to view and set values for their corresponding properties in the channel hierarchy of the Channel Editor. See [Accessing the Channel Editor](#) on page 1964.

Using Custom Particles

You can create particle streams using your own 3D objects or text. You can also use the shape of any surface for each particle. For example, create custom particles using a light source, 3D object, or surface as a particle generator. See [Generating Particles](#) on page 2324.

To use a 3D object or text as a custom particle:

- 1 From the node bin, add a particle generator to your scene.
- 2 In the schematic, double-click the Particle Generator node to access the Generator menu.



(a) Interactive Type box (b) Render Type box

- 3 From the Render Type box, select Node as the particle type and change the Interactive Type box to Node to view the 3D object or text as you make changes to your particle stream.
- 4 Import the 3D object or create the text. See [Importing 3D Models](#) on page 2274 or [Creating 3D Text](#) on page 2300.

TIP The 3D object or text used for the custom particle can also include a deformation mesh. See [Deforming Models and Surfaces](#) on page 2296.

- 5 In Schematic view, rename your 3D object or text “ParticleDraw”. This name is case sensitive so make sure it is typed exactly as shown.
- 6 Parent the particle generator to the 3D object or text.
If you want to add transformations, such as rotating all the particles, parent the particle generator to the axis of the 3D object or text as shown in the next step.
- 7 Hide the 3D object or text.

The particle generator uses the 3D object or text named ParticleDraw. The following figure shows the schematic and the result of using the letter A as a custom particle and a light source as the particle generator.

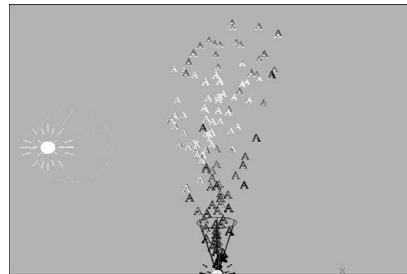
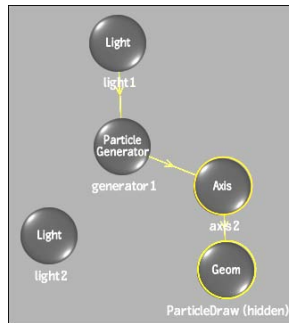

To use a surface as a custom particle:

- 1 Add a particle generator.
You can use a light source, 3D object, or surface as a particle generator. See [Generating Particles](#) on page 2324.
- 2 Select Node as the particle type in the Render Type box. To view the surface as you make changes to your particle stream, change the

Interactive Type box to Node as well. See [Setting Particle Rendering Properties](#) on page 2332.

- 3 Add a surface to the scene. It can be an image, a bilinear, a bicubic, or an extended bicubic surface. See [Adding Surfaces](#) on page 2178.

NOTE You do not have to apply media to the surface because the particle generator only uses the surface's shape and not its media. To have an image appear on each particle, you have to apply a texture to the particle generator. See [Applying Textures to Particles](#) on page 2339.

- 4 Rename your surface "ParticleDraw". This name is case sensitive so make sure it is typed exactly as shown.

- 5 Parent the particle generator to the surface.

If you want to add transformations, such as rotating all the particles, parent the particle generator to the axis of the surface as shown in the next step.

- 6 Hide the surface.

The following figure shows the schematic and the result of using a bicubic surface as a custom particle and a light source as the particle generator. The shape of the bicubic surface is animated and its axis is used to rotate the particles.

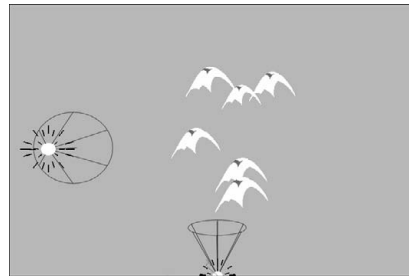
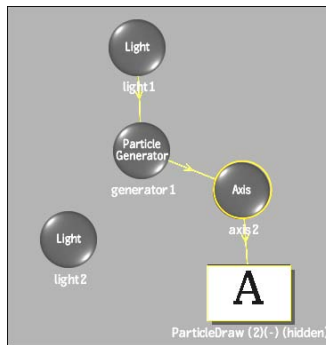

NOTE You can animate the shape of a bilinear, bicubic, or extended bicubic surface, and have the particles reflect the animation.

Applying Textures to Particles

You can apply textures to particles using the same method as applying textures to 3D objects and text. You can also set its texture mapping using the Texture menu.

To apply a texture to a particle stream of spheres:

- 1 Create a particle generator.
- 2 From the Render Type box, select Spheres as the particle type. To view the 3D object or text as you make changes to your particle stream, change the Interactive Type box to Spheres as well. See [Setting Particle Rendering Properties](#) on page 2332.
- 3 In the schematic, select the Particle Generator.
- 4 From the Node bin, double-click the Texture node.
A texture is added using the currently selected media and is parented by the particle generator.
- 5 Apply the appropriate media to the Texture element and set the texture mapping.

See [Adding Textures](#) on page 2284.

For example, the following shows the schematic and the result of a particle stream using spheres and a texture. Reflection is selected as the texture mapping, making each particle resemble a glass ball.

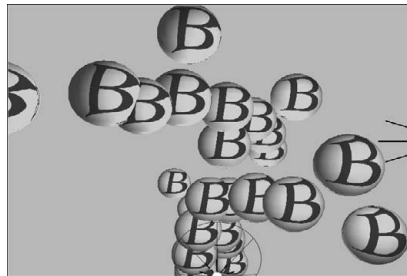
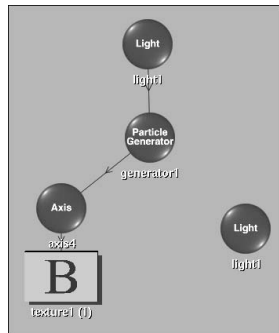

Exploding Objects and Surfaces

Whether you use a 3D object or a surface, exploding works much the same way. The shape of the 3D object or the surface is recreated by the particle generator, then the shape is exploded into polygons. For this to work correctly, the original 3D object or surface must be hidden.

Exploding Objects

The properties used to explode an object cannot be animated. When something explodes, it happens at a single point in time. This means that all the settings in the Particle Generator menu are used at once, at the beginning of the explosion.

To explode a 3D object:

- 1 Import a 3D object or create 3D text.
- 2 In the schematic, select the 3D object.
- 3 Add a particle generator. See [Generators](#) on page 2322.
- 4 From the Particle Generator menu, select Explode from the Stream Type box.

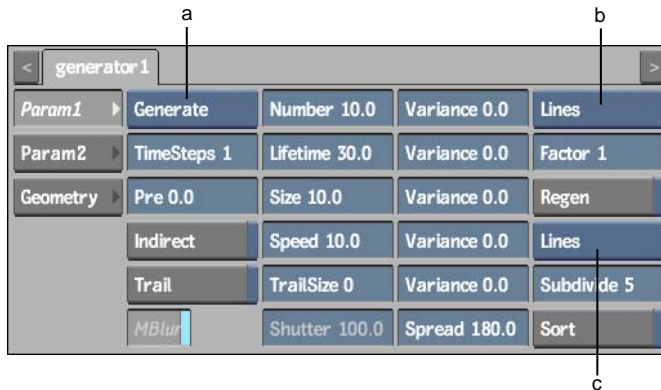

(a) Stream Type box (b) Interactive Type box (c) Render Type box

- 5 From the Render Type box, select Polygon as the particle type.

To view the explosion as you make changes to your particle stream, change the Interactive Type box to Polygon as well. See [Setting Particle Rendering Properties](#) on page 2332.

- 6 In the Number field, set the number of polygons to be removed from the 3D object with each pass. For example, if you specify 10 as the number of polygons per frame, then at each frame, 10 polygons are removed from the 3D object.
- 7 Set the other properties in the PartGen menu. See [Customizing the Particle Stream](#) on page 2328.
- 8 Hide the 3D object or 3D text.

The following figure shows the schematic and the result of exploding a 3D object of an apple. The number of polygons is set to 200. The result shows frame 20.

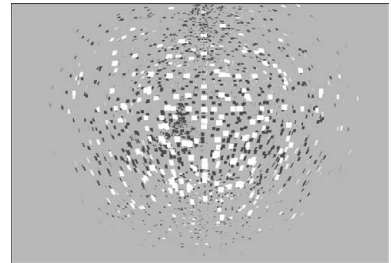
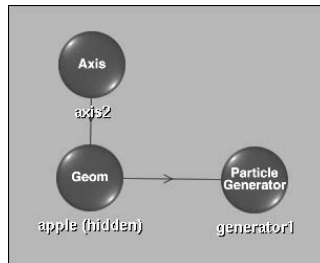

Exploding Surfaces

To make the media applied to the surface appear during the explosion, you must also apply a texture to the particle generator.

To explode a surface:

- 1 Select or add a surface and adjust its shape, position, rotation, and other attributes. See [Adding Surfaces](#) on page 2178.
- 2 Select the surface in Schematic view and add a particle generator. See [Generators](#) on page 2322.
A particle generator is automatically connected to the surface.
- 3 From the Particle Generator menu, select Explode as the Stream Type.

- 4 Select Polygon as the particle type from the Render Type box. To view the explosion as you make changes to your particle stream, change the Interactive Type box to Polygon as well. See [Setting Particle Rendering Properties](#) on page 2332.
- 5 Set the other properties in the Particle Generator menu. See [Customizing the Particle Stream](#) on page 2328.
- 6 In the Rendering section of the Action Setup menu, adjust the resolution.

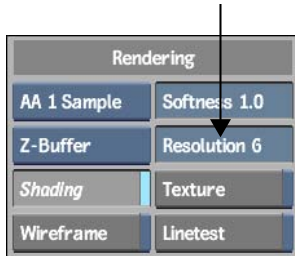

Resolution is used to set the size of the polygons exploded from the surface. The higher the resolution, the larger the polygon.

- 7 Hide the surface.
- 8 Select the particle generator in Schematic view.
- 9 From the Node bin, double-click the Texture node to add a Texture object. A Texture object appears in the schematic and is parented by the particle generator.
- 10 Double-click the texture and, in the Texture menu, select Wrap from the Texture Mapping box.
- 11 Apply the appropriate media to the Texture element and set the texture mapping.

The following figure shows the schematic and the result of exploding a surface. The number of polygons is set to 200. Resolution is set to 6, which is the default setting. Texture mapping is set to Wrap.

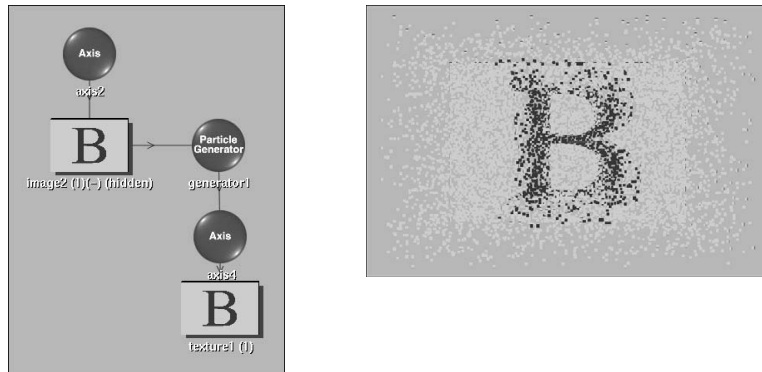

Manipulating Particles

You use manipulators to direct the particle stream and create a number of different effects, such as a swirling vortex, a swarm of objects orbiting a point, or a waterfall. A particle stream can have an unlimited number of manipulators. Manipulators only influence the particle stream that parents them.

When manipulating particles, you use the Particle Manipulator menu to set a manipulator's type, magnitude, power, and damping properties, as well as position, rotation, and scale.

Particle manipulators can be animated using motion paths. You can use the same operations on a particle manipulator that you use on an axis. See [Accessing the Axis Menu](#) on page 2171.

To create a particle manipulator:

- 1 In the schematic, select the particle generator that you want the manipulator to influence.
- 2 From the Node bin, double-click the Particle Animator node.
A particle animator element is added to the scene and parented by the selected Particle Generator element.

Setting Manipulator Properties

You use the Particle Manipulator menu to select the type of manipulator, its speed and position, and the power of its falloff. To access the Particle Manipulator menu, double-click the particle animator node in the schematic, or follow the tab population rules for the Object menu (see [Selecting Objects and Populating Menu Tabs](#) on page 2102).

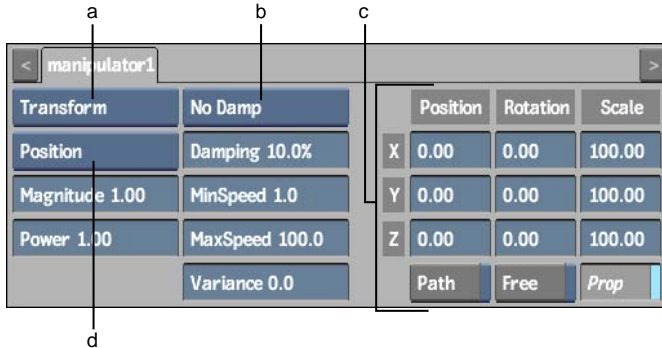

(a) Manipulator Type box (b) Damping box (c) Axis controls (d) Influence box

The particle manipulator controls are described as follows.

Manipulator Type box Select which type of manipulator to use.

Select:	To:
Gravity	Simulate the effect of gravity. See Simulating Gravity on page 2348.
Transform	Apply transformations from the Axis menu to the position or speed of each particle. See Applying Transformations on page 2347.
Vortex	Mimic the effect of a vortex. See Creating a Vortex Effect on page 2349.
Acceleration Point	Pull particles toward a point. See Using an Acceleration Point Manipulator on page 2350.
Acceleration Line	Pull particles toward a line. See Using an Acceleration Line Manipulator on page 2351.
Acceleration Plane	Pull particles toward a plane. See Using an Acceleration Plane Manipulator on page 2352.
Path	Make the particles follow a path. See Forming a Particle Path on page 2353.

Select:	To:
Function	Enter a mathematical expression to use as a particle manipulator. See Using a Function as a Manipulator on page 2354.

Influence box A particle manipulator can have two types of influence: position or speed. Use the Influence box to select whether the manipulator influences each particle's position or speed.

Set the initial speed of each particle using the Speed field in the Surface Particle Generator menu.

By selecting Speed in the Influence box located on the Particle Manipulator menu, each particle's speed is changed with each pass by the selected manipulator.

When you influence by position, the position is applied only once. For example, the following figure uses a gravity manipulator to illustrate the difference between position and speed. The gravity manipulator on the left uses the default gravity manipulator with a magnitude of 4 and with position as the influence. The gravity manipulator on the right uses exactly the same settings except the influence is set to speed.

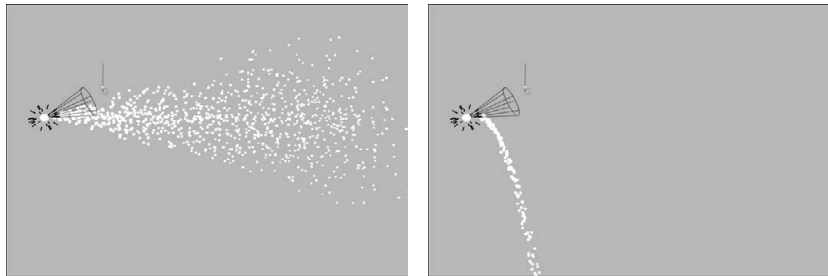

Magnitude field Magnitude is a unit of measurement specific to each manipulator. It is used by each manipulator for everything from extra scale when using Transform, to a pixel per frame acceleration factor when using AccPoint, AccLine, or AccPlane. By default, the Magnitude field is set to 1.0.

Power field Power is the amount of falloff from the centre of a manipulator. By default, power is set to 1. This means that each particle's speed or position is influenced if the particle is within a 100-pixel radius of the manipulator. When the power is set to 2, the falloff is approximately 200 pixels. The higher the power, the higher the falloff from the manipulator.

If you specify 0 as the power, there is no falloff; the manipulator's influence is universal. This means that a particle is affected no matter where it is located in the scene. A negative value makes particles that are farther away affected by the manipulator.

Damping box Damping affects the speed of particles by applying friction based on each particle's mass, size, or both. Select the type of friction from the Damping box.

Select:	To:
No Damp	Turn off damping. Particles have no friction.
Damp Mass	Activate damping based on mass. The greater a particle's mass, the slower its speed in relation to the manipulator. You set the mass using the Mass channel in the Channel Editor.
Damp Size	Activate damping based on particle size. The larger the particle, the slower it moves in relation to the manipulator. This corresponds with the Size field in the Surface Particle Generator menu.
Damp Both	Activate damping based on mass and particle size.

Damping Percentage field The damping percentage is the percent value of how much Damp Mass, Damp Size, or Damp Both affects the position or speed of the particles.

MinSpeed and MaxSpeed fields The Min Speed and Max Speed fields specify the minimum and maximum speed range for particles affected by damping. Particles are not decelerated below the minimum speed or accelerated above the maximum speed. Both speeds are specified in pixels per frame.

You can use the Min and Max Speed fields to force a minimum and maximum speed on particles without damping. To do this, select Damp Mass, Damp Size, or Damp Both. Change the Damping Percentage to 0% and change the Min and Max Speed fields accordingly. Use this feature to stop particles from being over accelerated.

For example, when you use a vortex manipulator, the closer particles pass to the centre of the vortex, the more they are accelerated. Occasionally, a particle may be over accelerated and shot too far, too fast. By forcing a maximum speed, particles are not accelerated past a certain value.

Axis controls Use these controls to animate the position, rotation, and scale of the manipulator.

Control	Description
Position	Use the Position X, Y, and Z fields to displace each particle along the X, Y, and Z axes.
Rotation	Use the Rotation X, Y, and Z fields to rotate each particle. Each particle is not the centre of its rotation. Particles rotate around the manipulator's axis.
Scale	Use the Scale X, Y, and Z fields to increase or decrease the speed or position of each particle along the X, Y, and Z axes. For example, if speed is the selected influence, a Scale X of 100% has no effect while a Scale X of 105% increases the speed along the X axis by 5% with each pass. Enable Prop to proportionally scale the axes.

Enable the Path button to animates the position of the axis using a spline drawn in the scene. Disable Path to animate the position of the axis using explicit animation. See [Creating a Motion Path](#) on page 2023.

Free button Enable to ignore transformations from parent axes.

Applying Transformations

Use a transform manipulator to apply the accumulated transformations from the Axis controls to the position or speed of each particle. Unlike other manipulators, the transform manipulator is not used to position the manipulator in the scene. Transform manipulators are always placed at the centre of the particle stream they influence.

The following figure provides an example of creating a particle stream influenced by a transform manipulator. The settings in the Particle Manipulator menu and the resulting effect are shown.

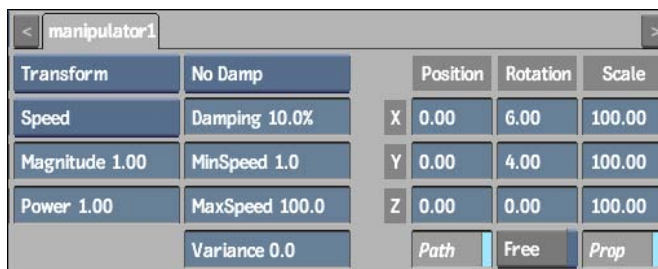

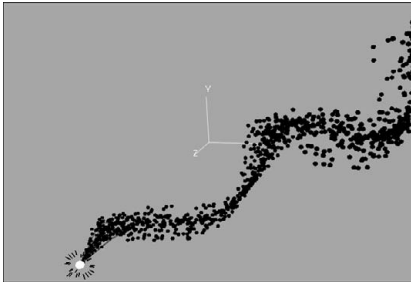

In the Particle Manipulator menu, use Magnitude as an extra scaling factor whose sensitivity depends on the transformations in the Axis menu. For example, the following is a copy of the above particle stream with Magnitude set to 0.99 instead of 1.0; the particle generator and transform settings are the same.

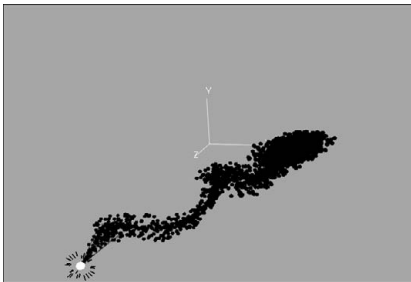

Simulating Gravity

Use a gravity manipulator to simulate the effects of gravity. This manipulator works on speed or position. The Power field has no effect.

Magnitude specifies the gravitational pull in pixels per frame. A higher magnitude produces a higher gravity, which exerts a greater influence on each particle.

The icon for a gravity manipulator uses an arrow to indicate the direction of the influence. You can change the position and rotation of the arrow using the Axis menu. You can also change the scale of the gravity manipulator as another way of increasing its influence.

The following figure provides an example of creating a simple particle stream influenced by the gravity manipulator. The settings in the Particle Manipulator menu and the resulting effect are shown.

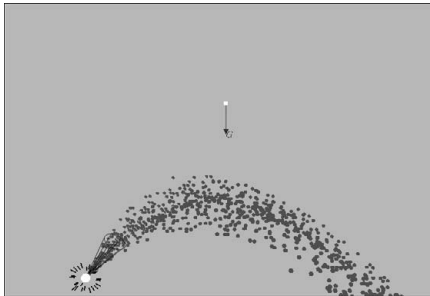

Creating a Vortex Effect

Use a vortex manipulator to influence the motion and rotation of particles. This manipulator works on speed or position. Power is the falloff from the centre of the vortex and magnitude is used for the scale of the vortex's rotation.

You can also use the Axis controls to apply additional transformations to the vortex. Scale changes the size of the vortex, and rotation affects the spin of the vortex.

The following figure provides an example of creating a simple particle stream influenced by the vortex manipulator. The settings in the Particle Manipulator menu and the resulting effect are shown.

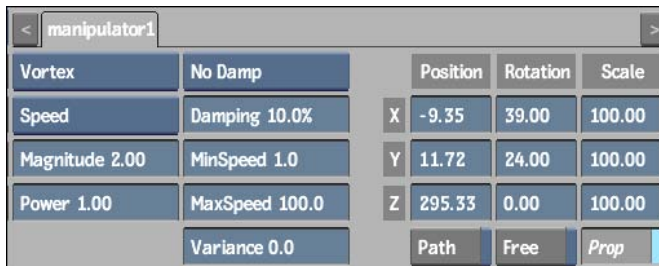

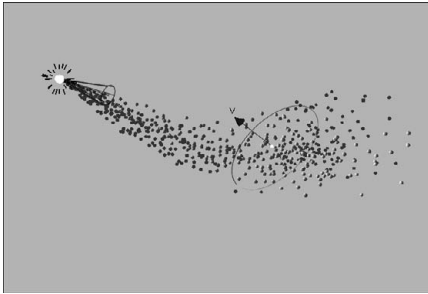

NOTE The icon used to show a vortex does not indicate the limit of the vortex. The icon is only used to represent the vortex in the scene and is not meant as an accurate depiction of the size, strength, or limit of the vortex's influence.

Using an Acceleration Point Manipulator

The Acceleration Point manipulator mimics the gravitational pull between bodies. Unlike the gravity manipulator, which pushes particles in a specific direction, Acceleration Point continually pulls particles toward itself on all three axes (X, Y, Z).

Magnitude is the gravitational pull in pixels per frame. A higher magnitude produces a higher gravity, which results in a greater influence. Power is the distance from the centre, or the radius, of the pull.

The following figure provides an example of creating a simple particle stream influenced by the Acceleration Point manipulator. The settings in the Particle Manipulator menu and the resulting effect are shown.

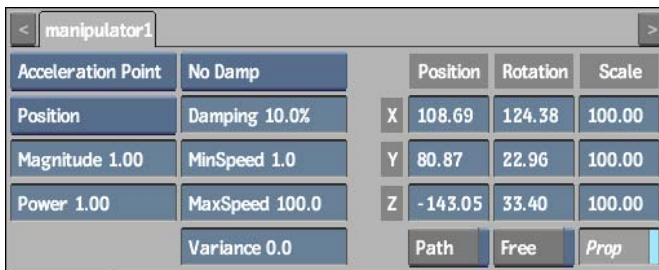

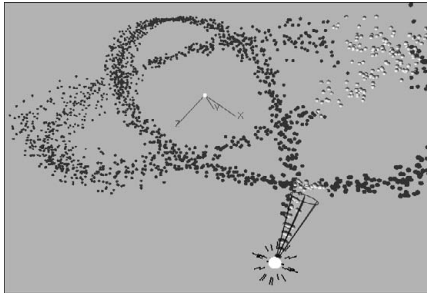

NOTE The Axis controls are used only to position the Acceleration Point in the scene. Scale and rotation have no effect.

Using an Acceleration Line Manipulator

Like Acceleration Point, the Acceleration Line manipulator continually pulls particles toward itself. Acceleration Line, however, manipulates particles on two axes instead of all three.

You can set the two axes by rotating the manipulator using the Rotation fields. The Axis controls are also used to position the Acceleration Line manipulator in the scene. Scale may change the appearance of the Acceleration Line icon, but has no effect on particles.

Magnitude is the gravitational pull in pixels per frame. A higher magnitude produces a higher gravity, which results in a greater influence. Power is the falloff from the manipulator, or the radius of the pull.

The following figure provides an example of creating a simple particle stream influenced by the Acceleration Line manipulator. The settings in the Particle Manipulator menu and the resulting effect are shown.

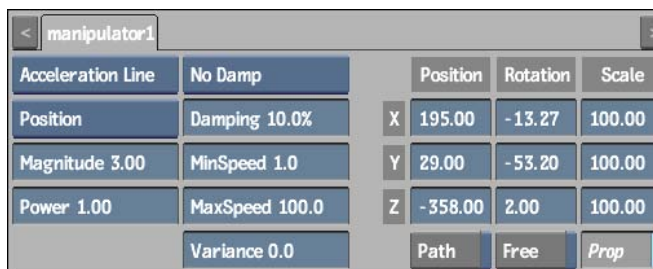

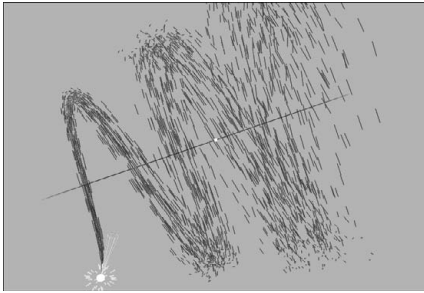

Using an Acceleration Plane Manipulator

Like Acceleration Point and Acceleration Line, the Acceleration Plane manipulator continually pulls particles toward itself. With Acceleration Plane, however, particles are manipulated on only one axis set by rotating the plane using the Rotation fields.

Use the Axis controls to position the Acceleration Plane manipulator in the scene. The Scale and fields are not used.

Magnitude is the gravitational pull in pixels per frame. A higher magnitude produces a higher gravity, which results in a greater influence. Power is the falloff from the manipulator, or the radius, of the pull.

The following figure provides an example of creating a simple particle stream influenced by the Acceleration Plane manipulator. The settings in the Particle Manipulator menu and the resulting effect are shown.

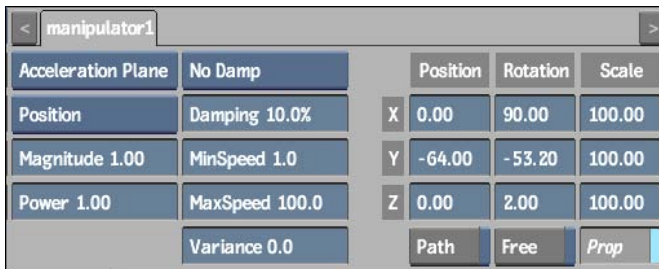

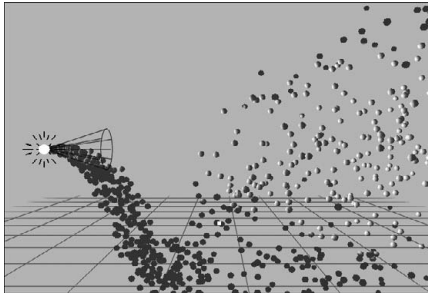

NOTE Because Acceleration Plane influences particles on only one axis, the effect may not be noticeable until you change views or orbit the camera.

Forming a Particle Path

Use the path manipulator to make particles follow the motion of a path.

The motion of a path is applied to the speed or position of each particle. Note that particles do not directly follow the path. You can make the particles seem to follow the path by lowering the particle speed and magnitude, which is used as a scaling factor. Power is not used.

Use the Axis controls to animate the path. You can also use the Rotation and Scale fields to add extra transformations.

The following figure provides an example of creating a simple particle stream influenced by the path manipulator. The settings in the Particle Manipulator menu and the resulting effect are shown.

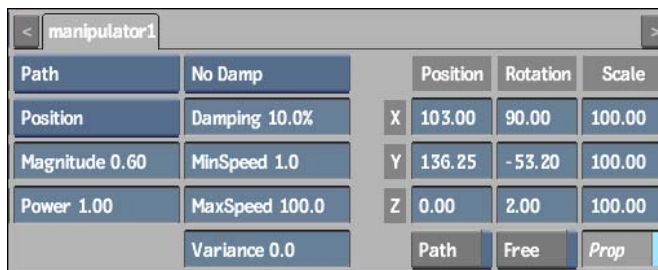

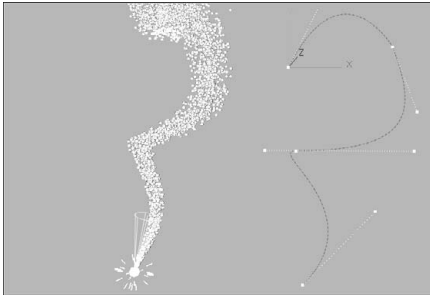

Using a Function as a Manipulator

Select Function to specify your own mathematical expressions to be used as a particle manipulator. You can use the channels from the Particle Manipulator and Particle Generator menus in your expressions, as well as arithmetic operations, mathematical conventions, functions, and constants.

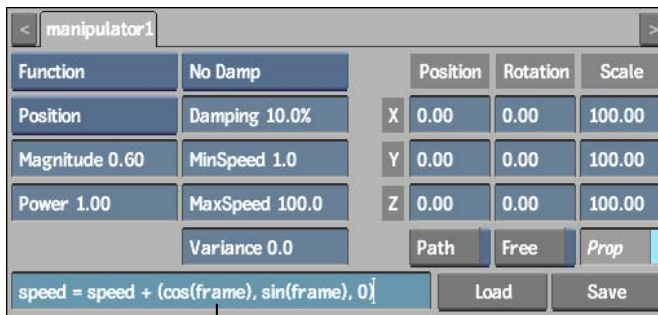

(a) Expression field

The arithmetic operators, conventions, constants, and functions that you can use in your expressions are listed in the following sections. Before writing your own expressions, you should understand the following:

- A vector is a 3D coordinate written using the convention (x, y, z) where x , y , and z are separate values.

For example, `pos` represents the position of each particle. If you want to increase the Y position of each particle with each pass, use the expression `pos = pos + (0,1,0)`.

- Make sure assigned values and vector values are within an acceptable range. For example, transparency (opacity of each particle) is a value between 0 and 1. The expression `transparency = size` does not work unless `size` (particle size from the PartGen menu) falls between 0.0 and 1.0. To make transparency dependent on size, `size` must be divided by an appropriate value. For example, if `size` is between 1 and 10, use the expression `transparency = size / 10`.
- Some functions return scalars and other functions return vectors. Make sure that when you use a function, it returns the right value and that this value is within an acceptable range. For example, `rgb` is a vector of values between 0.0 and 1.0. The expression `rgb = (0, 0, noise3(pos))` gives an error because `noise3` returns a vector. The expression `rgb = (0, 0, frame)` does not give an error, but `frame` is the frame number and it is never less than 1. This means the blue channel is always set to full blue (1).
- You can specify more than one function by separating each with a semicolon. For example, to place the two expressions in the Expression field, you would type:
`speed = speed + pos; pos = pos + (0,size,0)`

Expression field operators are listed in the following table.

Operator	Description
=	Equals
+	Addition
-	Subtraction
*	Multiplication
/	Division
%	Percentage

Operator	Description
(x,y,z)	Vector where x,y, z may also be the results of functions
$==$	Equivalence
$!=$	Not equal to
$<$	Less than
$<=$	Less than or equal to
$>$	Greater than
$>=$	Greater than or equal to

Particle and manipulator variables that you can use in the Expression field are listed in the following table.

Particle Symbol	Description
pos	Position, a vector (x,y,z) .
speed	Speed, a vector (x,y,z) .
rgba	Red, green, blue, and alpha colour channels for each particle, expressed as a 4D vector (r,g,b,a) . Each component is a value between 0 and 1.
rgb	Red, green, and blue colour channel, expressed as a vector (r,g,b) . Each component is a value between 0 and 1.
red	Red channel, a value between 0 and 1.
green	Green channel, a value between 0 and 1.
blue	Blue channel, a value between 0 and 1.
transparency	Transparency of each particle (surface or geometry), a value between 0 and 1.
lifetime	Lifetime of each particle, in frames.
lifetimeL	A value between 1.0 and 0.0 where 1.0 is when a particle is first generated and 0.0 is when it ends.

Particle Symbol	Description
mass	Mass of each particle.
size	Size of each particle, in pixels.
tailSize	Width of the particle's tail, a value between 0 and 1.

The following variables are read only. You cannot change them in the Expression field, but you can use them in your calculations.

Manipulator Symbol	Description
frame	Current frame
magnitude	Value from the Magnitude field
power	Value from the Power field
damping	Value from the Damping field
minSpeed	Value from the MinSpeed field
maxSpeed	Value from the MaxSpeed field

Single argument arithmetic functions are listed in the following table.

One Argument	Description
$\sin(a)$	Sine of a
$\cos(a)$	Cosine of a
$\tan(a)$	Tangent of a
$\text{asin}(a)$	Arcsine of a
$\text{acos}(a)$	Arccosine of a
$\text{atan}(a)$	Arctangent of a
$\text{exp}(x)$	Exponential function of x
$\text{expm1}(x)$	Equivalent to $\text{exp}(x)-1$
$\log(x)$	Natural logarithm of x

One Argument	Description
<code>log10(x)</code>	Base 10 logarithm of x
<code>log1p(x)</code>	Equivalent to $\log(1 + x)$
<code>sqrt(x)</code>	Square root of x
<code>abs(x)</code>	Absolute value of x
<code>trunc(x)</code>	Integer value of x
<code>floor(x)</code>	Smallest integer greater than or equal to x
<code>ceil(x)</code>	Largest integer greater than or equal to x
<code>round(x)</code>	x rounded to the nearest integer
<code>radians(a)</code>	a converted to radians
<code>degrees(r)</code>	r converted to degrees
<code>sign(x)</code>	Returns +1 or -1 depending on the sign of x
<code>length(p)</code>	Euclidean length of point p
<code>noise(v)</code>	Noise of vector v , returns a float
<code>fnoise(v)</code>	Fractal noise vector v , returns a float
<code>noise3(v)</code>	Noise of vector v , returns a vector

Making Particles Transparent

The following example illustrates how to make particles become transparent as they reach the end of their lifetime using the expression `transparency = lifetimeI`. The settings in the Particle Manipulator menu, Particle Generator menu, and the resulting effect are shown.

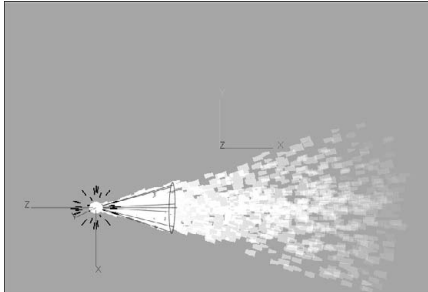
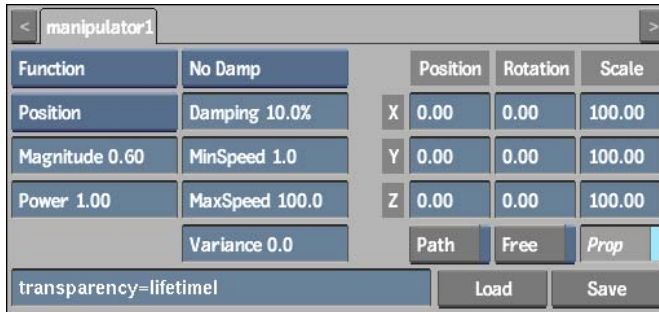
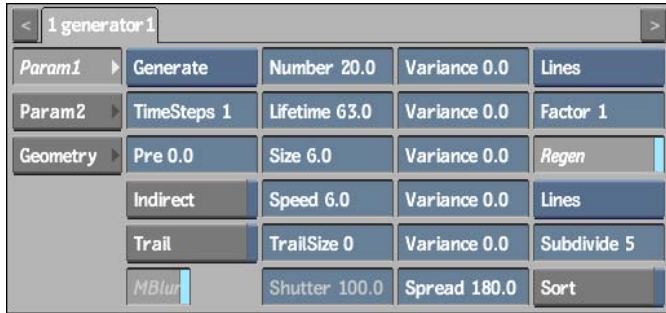

Making Particles Spin

The following example illustrates how to spin particles using the expression:

speed = speed + (cos(frame), sin(frame), 0)

The settings in the Particle Manipulator menu, Particle Generator menu, and the resulting effect are shown. Notice that the particle Timestep value is increased to improve the accuracy of the particle stream.

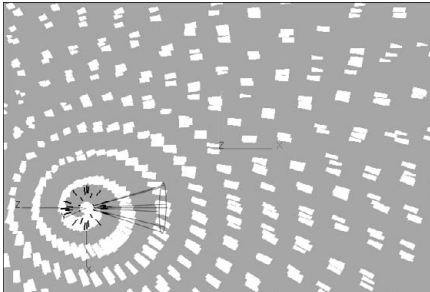
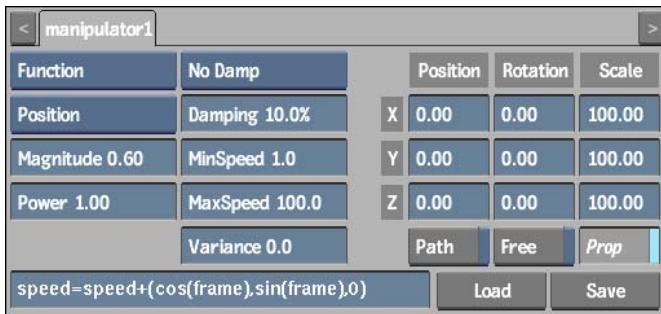

Arithmetic functions that have two or more arguments are listed in the following table.

Symbol	Description
$\text{atan}(x,y)$	Arctangent of y over x
$\text{pow}(x,y)$	x to the power of y
$\text{mod}(x,y)$	Returns the remainder of dividing x by y
$\text{min}(x,y)$	Minimum value of x and y

Symbol	Description
$\max(x,y)$	Maximum value of x and y
$\text{step}(x,y)$	Returns 0 if $x < y$, 1 if $x \geq y$
$\text{dot}(v1, v2)$	Dot product of two vectors; returns a scalar
$\text{cross}(v1, v2)$	Cross product of two vectors; returns a vector
$\text{turbulence}(v, o)$	Turbulence of vector v and octave o ; returns a float
$\text{turbulence3}(v, o)$	Turbulence of vector v and octave o ; returns a vector
$\text{smoothstep}(min, max, x)$	Returns 0 if $x < min$, 1 if $x \geq max$; if neither are true, returns a hermite interpolation between 0 and 1
$\text{clamp}(x, min, max)$	x clamped to the range $[min, max]$

The following example illustrates how to create animated turbulence using the expression:

pos = pos + turbulence3(pos, 1) * power

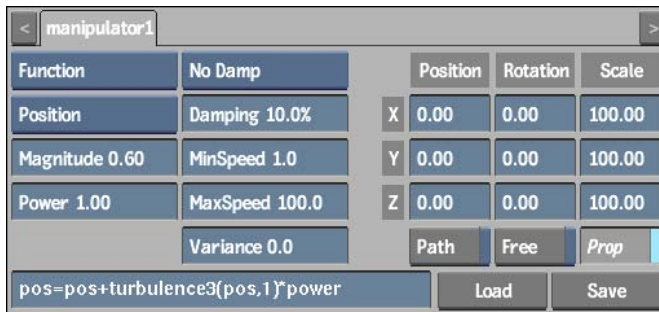
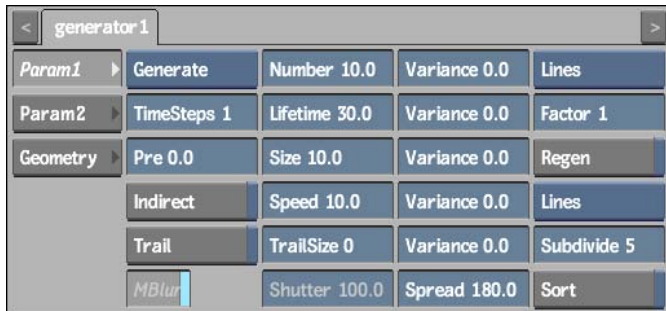

Bouncing Particles

You can bounce a particle stream off either an image or a bouncer. When particles bounce off an image, they bounce off the surface wherever its matte is white or grey. Particles only pass through the areas of the image where its matte is pure black. If a surface's matte is turned off, particles bounce off the entire surface.

When you use a bouncer, it must be the parent of an axis or a light source. A bouncer shows up as a sphere in the Action scene when you use it with a light source. Otherwise, all other types of surfaces create flat bouncers.

Whether you use a bouncer or an image, bouncing particles are controlled using the Particle Bouncer menu.

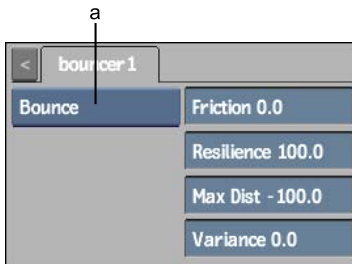

(a) Bounce Type box

Bounce Type box Selects the type of bounce. There are four types of bouncing that you can perform.

Select:	To:
Bounce	Bounce particles off images or bouncers. All bounce properties work with this type of bounce behaviour.
Extinct	Make particles disappear when they reach a surface. Only the Max Dist parameter works with this type of bounce.
Generator	Create an additional particle stream when particles bounce. When using this bouncing behaviour, you must add another particle generator. See Combining Particle Streams on page 2366.
Generator+Extinct	Make particles disappear and create an additional particle stream when particles reach a parented surface. Only the Max Dist parameter works with this type of bounce unless the particles end in another particle stream. See Combining Particle Streams on page 2366.

Friction field Friction is a percentage that influences the angle of bouncing particles. The greater the percentage, the more particles bounce straight. For example, in the left figure, Friction is set to 100%, which bounces particles almost perfectly straight. In the figure on the right, Friction is set to 20%, which causes the particles to deviate once they make contact (bounce).

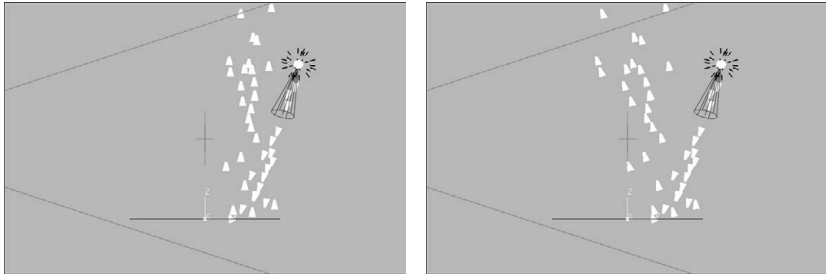

Resilience field Resilience determines the amount of energy lost with each bounce. For example, at a Resilience of 100%, the figure on the left shows there is no energy lost between bounces. Each bounce is at the same height as the last bounce. When Resilience is set to 80%, 20% of energy is lost between each bounce. At 50%, the figure on the right shows the height of each bounce is reduced by 50%. Note that Friction is set to 0 for both examples.

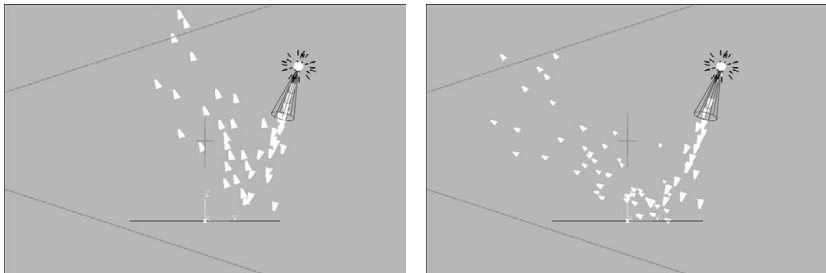

Max Dist field Specifies the maximum distance a particle travels past an image for it to still bounce or become extinct.

Because an image is only a pixel in width, it is unlikely that fast moving particles will hit the image directly. Max Dist acts like a buffer zone after the surface. If particles fall through the surface, set the Max Dist to -100. Particles that miss the surface by 100 pixels will still bounce.

If particles still fall through the surface, increase the timestep to increase the accuracy of the particle stream.

Bouncing Particles Off an Image

You can bounce particles off an image surface only. Particles will bounce off bilinear and bicubic surfaces, but only on the original flat surface and not on any changes in shape.

To create the bouncing particle effect, you start with a particle generator. When you determine the image off which you want to bounce particles, you must parent the particle generator to the image; otherwise, the particles will ignore the image. The following figure shows the schematic and the result of bouncing particles off an image using a light source as a generator.

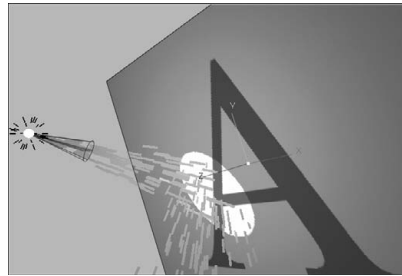
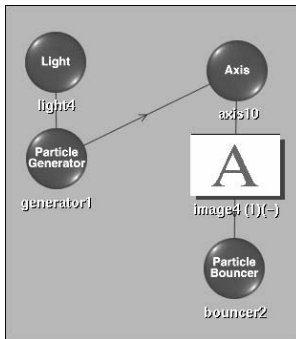

To bounce particles off an image:

- 1 Add an image off which you want to bounce particles.
- 2 Create a particle generator using a light source, 3D object, or surface as a particle generator. See [Generating Particles](#) on page 2324.
- 3 Parent the particle generator to the image's axis.
- 4 Select the image's axis and, in the Axis menu, enable Free.
The parent-to-child relationship between the particle generator and the image is severed, allowing you to place the image in the scene more easily. Any transformations and animations from the particle generator are not passed to the image.
- 5 Move the image in the scene until the particle stream passes through it. To do this, you may have to switch views or orbit the camera.
- 6 In the schematic, select the image.
- 7 From the Node bin, double-click the Particle Bouncer node.

A particle bouncer is added and parented by the image.

- 8 To access the Particle Bouncer menu, double-click the particle bouncer node in the schematic, or follow the tab population rules for the Object menu (see [Selecting Objects and Populating Menu Tabs](#) on page 2102).

Bouncing Particles Off a Bouncer

A particle bouncer element is added and automatically parented to a light source. The particle bouncer may not be parented by the right light source or axis. The bouncer must be parented by the light or axis added in the last step.

NOTE The shape of the bouncer depends on the particle generator type.

The following figure shows the schematic and the result of bouncing particles off a bouncer.

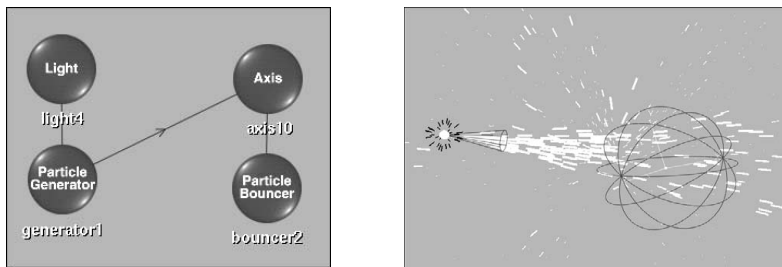

To bounce particles off a bouncer:

- 1 Create a particle generator using a light source, 3D object, or surface as a particle generator. See [Generating Particles](#) on page 2324.
- 2 Add an axis or a light source to the scene.
- 3 From the Node bin, double-click the Particle Bouncer node.
- 4 If you are using an axis to set the position of the particle bouncer, select the axis and go to step 5. Otherwise, go to step 7.
- 5 In the Axis menu, enable Free to sever the parent-to-child relationship between the particle generator and the axis.

Any transformations and animations from the particle generator are not passed to the axis. This makes it easier to place the particle bouncer in the scene.

- 6 Parent the particle generator to the particle bouncer's axis or light source. You must parent the particle generator to the axis or light source; otherwise, the particles will ignore the particle bouncer.
- 7 In the Particle Bouncer menu, select Bounce from the Bounce Type box and set the appropriate bounce properties.

NOTE If the particle bouncer is not parented correctly, unparent the particle bouncer and make the axis or light source added in the last step its parent.

Combining Particle Streams

You can combine two or more particle streams by parenting them together. This has two possible results depending on whether the first particle stream ends or bounces off an object.

NOTE Multiple particles can be parented, but only in a straight line, that is, a particle can only be the particle of one other particle. For example Particle 1 can parent Particle 2, and Particle 2 can parent Particle 3 in the same scene.

Particles Generating Another Particle Stream

When each particle in the particle stream ends, the second particle stream begins. This can be used, for example, to create fireworks.

To make particles generate other particles:

- 1 Create a particle generator. You can use a light source, 3D object, or surface as a particle generator. See [Generating Particles](#) on page 2324.
- 2 In the schematic, select the Particle Generator.
- 3 Add another particle generator by double-clicking the Particle Generator node in the Node bin.
- 4 In the Particle Generator menu, set the second particle generator's Spread and other properties as appropriate. See [Setting Particle Properties](#) on page 2331.

NOTE In the Channel Editor's folder for the second particle generator, you can set the Spread_V channel to add variance to the value in the Spread field.

The following figure shows the schematic and the result of a particle stream that generates a second particle stream. The first particle stream generates spheres and the second particle stream generates quads.

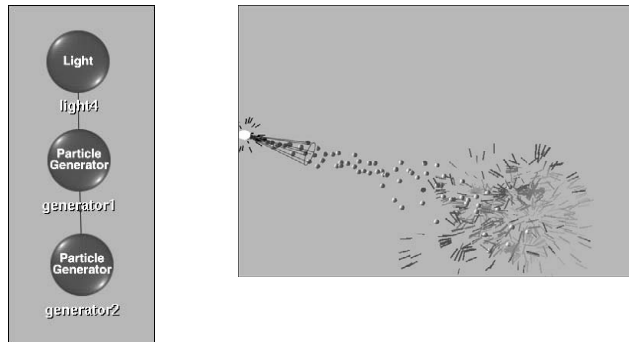

Particles Bouncing into Another Particle Stream

When bouncing particle off a bouncer, you can generate a second stream of particles. For example, use this technique to give the effect of water or sparks bouncing off an image.

There are two different effects that you can create depending on your bouncer's settings. The following example illustrates the Generator bounce type.

To make bouncing particles generate another particle stream:

- 1 Create a schematic that bounces particles off an image or a bouncer. See [Bouncing Particles](#) on page 2362.
- 2 In the schematic, select the Bouncer object.
- 3 In the Particle Bouncer menu, select Generator from the Bounce Type box.
- 4 Add another particle generator by double-clicking the Particle Generator node in the Node bin.
- 5 In the Particle Generator menu, set the particle generator's other properties as appropriate. See [Generating Particles](#) on page 2324.
- 6 In the Channel Editor, open the second particle generator folder to reveal the properties folder.

- 7 Set the Spread and Spread_V channels to control the spread of the second generator.

If you set the Spread to less than 180, you can also control the rotation of the second particle stream using the Friction field in the Particle Bouncer menu.

The following figure shows the schematic and the result of bouncing particles into another particle stream where the first particle stream continues after bouncing off an image surface. The first particle stream generates spheres and the second particle stream generates quads.

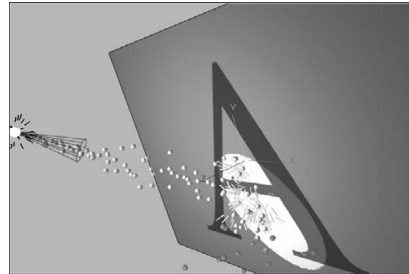
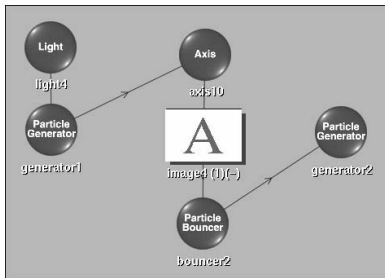

Sample Particle Setups

Ten particle setups are provided in the directory `/usr/discreet/<product home>/examples`. To load one of the setup files, open Action using a black frame as the front, back, and matte clips.

A brief description of each example particle setup is provided in the following table.

Setup File Name	Description
Bounce Example	Uses a gravity manipulator and a bouncer attached to an axis. The bouncer appears as a sphere in Camera view. The particles fall down and bounce off the bouncer.
Bounce Example 2	Uses a gravity manipulator and two image surface bouncers.
Bounce Example 3	Uses an Accpoint manipulator and a bouncer linked to an axis. The bouncer follows the Accpoint manipulator.

Setup File Name	Description
Explode Example	An example of exploding 3D text. The Geom node is hidden in Schematic view. The setup uses an Explode generator and Polygon particles. To add 3D text (Geom node), go to the Text menu, click the Text field and type the text string, then click Create.
Explode Example 2	An example of exploding an image surface. The image surface is hidden. Media1 is applied to the generator as a texture and uses Wrap mapping mode. Replace Media 1 with an image of your choice.
FireWorks Example	Uses two linked generators. The first generator generates few particles at each frame. When these reach the end of their lifetime, the second generator is activated.
Function Example	Uses a function manipulator that increases the particles' transparency as they reach the end of their lifetime.
Function Example 2	Uses a function manipulator with sine and cosine functions to modify the speed of the particles.
Node Example	Uses 3D text for the particles. The Geom node (the 3D text) must be named "ParticleDraw". The generator is parented to the axis of the Geom node, and the selected particle type is Node.
Transform Example	Uses a transform manipulator.

Part 13: Paint

Part 13 includes these chapters:

- [Batch Paint](#) on page 2373
- [Paint: Basics](#) on page 2405
- [Painting on the Canvas](#) on page 2419
- [Setting Brush Attributes and Modes](#) on page 2427
- [Using Filters and Special Effects Media](#) on page 2437
- [Using Wipe, Fill, and AutoPaint](#) on page 2451
- [Using Mattes in Paint](#) on page 2467
- [Using Graphics in Paint](#) on page 2475
- [Cutting and Pasting in Paint](#) on page 2511
- [Paint: Setups](#) on page 2523



Image courtesy of Click 3x

Topics in this chapter:

- [About Batch Paint](#) on page 2373
- [Accessing Batch Paint](#) on page 2374
- [Using Sources](#) on page 2376
- [Brush Attributes and Attribute Modes](#) on page 2382
- [Painting Brush Strokes](#) on page 2387
- [Using Paint Modes](#) on page 2392
- [Revealing Sources](#) on page 2396
- [Using Blending Modes](#) on page 2398
- [Using the Canvas](#) on page 2400
- [Previewing a Reveal Operation Using a Reference Image](#) on page 2402
- [Saving Setups and Preferences](#) on page 2404

About Batch Paint

Batch Paint is a system that provides a scalable matte painting, retouching, or restoration workflow in Batch. Due to its underlying technology, Batch Paint automatically scales strokes when changing the resolution, ratio, or bit depth of input clips, or when switching from Full Resolution to Proxy mode. Batch Paint supports “clipless” setups, which can be applied to any image input, while accurately reproducing the sequence of painted strokes.

The Paint node accepts a front and matte clip as input, and creates a result and output matte clip, respectively. You can paint on the result and output matte, with a selection of brushes in different paint modes.

Batch Paint also allows you to connect multiple sources and use them to paint the contents of source images onto the result. This paint operation, applied with the Reveal paint tool, can be used with in-context overlay over the result image. A front and matte clip can be connected as a source by connecting the clips to a source node. The content of source front and source matte input can be used to create brush strokes on the result and output matte.

Accessing Batch Paint

Paint is accessed from the Batch module.

To access Batch Paint:

- 1 From the Processing menu, click Batch.
- 2 In the Batch module node bin, double-click the Paint node or drag the node to the Batch schematic.
- 3 Attach a clip or node output to the front tab.
- 4 Attach a clip or node output to the matte tab. If a matte clip is not attached, the node interprets the missing input as a white clip.
- 5 In the Batch schematic, double-click the Paint node.

The Batch Paint menu appears.

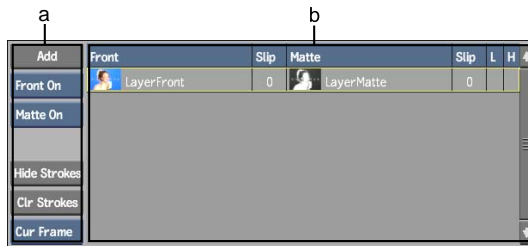

(a) Source controls (b) Sources List

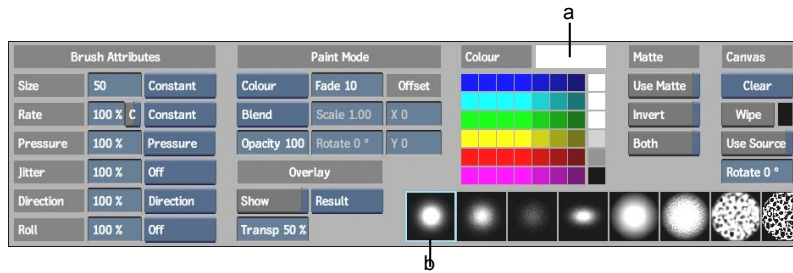

(a) Current Colour Pot (b) Current Brush

NOTE The Parent and Delete options in the Paint Tools box are standard Batch features and are not used in Batch Paint.

Source Controls and Sources List Displays the front clip, matte clip, and sources. The Sources list manages the sources attached to the current node. A source is composed of a front source and a matte source. See [Using Sources](#) on page 2376.

Brush Attributes Sets the size of the brush and other brush attributes affecting how paint is applied to the canvas. See [Brush Attributes and Attribute Modes](#) on page 2382.

Paint Mode Sets the type of paint operation that is applied to the brush. Some brushes paint in a colour; others use contents of the result or a source. See [Using Paint Modes](#) on page 2392 and [Using Blending Modes](#) on page 2398.

Matte controls Defines the area that can be used to paint. You can paint on the entire canvas or areas delimited by the matte properties. See [Restricting Strokes with the Source Matte](#) on page 2380 and [Restricting Brush Strokes](#) on page 2389.

Canvas controls Controls clearing and wiping the canvas at the current frame. See [Using the Canvas](#) on page 2400.

Colour pots Displays the default palette colours that can be used for brushes and wipes.

Brushes Displays default brush strokes.

The following views are available in Batch Paint.

Select:	To display:
Front (F1)	The front clip or Batch tree input. The modifications to the front create the result clip.
Matte (F3)	The matte clip or Batch tree input. The modifications to the matte create the output matte.
Source Front (F1 F1)	The source front that is selected in the Sources list.
Source Matte (F3 F3)	The source matte that is selected in the Sources list.
Result (F4)	The result image. Paint can be applied to the result.
Output Matte (F4 F4)	The output matte image. Paint can be applied to the output matte.

Using Sources

Sources are additional image data that can be used in Reveal paint operations and displayed as an overlay on the result or output matte. You can scale, rotate, and offset a source. Any transformations applied to a source will be displayed in Reveal paint strokes.

In the Batch Paint menu, all sources appear in the Sources list. The Sources list allows you to select sources to be hidden, cleared, or displayed as an overlay. The first entry in the list is the front clip and matte clip.

In the Batch schematic, source clips are connected to a Paint node through a source node, which accepts a source front and source matte input.

A source can be a clip or the result of any Batch process, and can include a front and/or matte clip. You can add a source node from the Batch menu or the Batch schematic.

If a clip with frames that are missing media is attached to a source node, the Paint node processes incoming frames set to No Media as transparent. Strokes created with the source are stored, although they are not visible on the canvas at frames with No Media input. See [Defining Missing Media Output](#) on page 1290.

When adding a source input, it is recommended that you use clips as input, or cache the node closest to the source node instead of parenting a large Batch

tree to a source node. This speeds up processing when changing frames, making for a more interactive experience.

Front	Slip	Matte	Slip	L	H
LayerFront	0	LayerMatte	0		
silk	0	silk	0		

a
b

c
d

(a) Front (b) Matte (c) Source front (d) Source matte

When you delete a source, it is removed from the Sources list, along with its associated strokes. When you clear a source, it remains in the Sources list, but all strokes are removed.

Adding a Source

When you add source, it includes both source front and source matte input. When you add a source front only, a black matte will automatically be created.

To add source node, front source and matte source:

- 1 In the Batch Paint menu, click Add.
The Desktop reels appear.
- 2 Select a source front clip, and then a source matte clip.
- 3 Click Exit Clip Select to return to the Batch Paint menu.

In the Sources list, the source is added. In the schematic, the process tree is updated: a source node with the selected clips is connected to the Paint node.

Add	Front	Slip	Matte	Slip	L	H	↑
Front On	LayerFront	0	LayerMatte	0			
Matte On	silk	0	silk	0			

To add a source node only:

- 1 Hold **Ctrl** and click Add to add a source node.
The source node is added and connected to the Paint node.

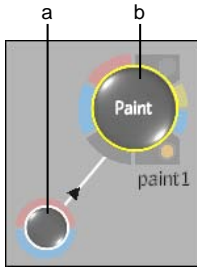

(a) Source node (b) Paint node

- 2 Connect clips or process tree input to the source node's front and matte inputs.

Removing a Source

You can remove a source clip from the Sources list. If you disconnected a source clip from the source node, the entry exists in the Sources list, but the clip name and proxy no longer appear. Because the stroke information is stored in the node, you can reconnect the same clip or a different clip to the source node, and the stroke information is preserved. All strokes in the canvas using the source are repainted using the new source clip.

When you delete a source node, the entry is removed from the Sources list, and the strokes stored in the node are deleted permanently.

To remove a source clip from the Sources list:

- 1 In the Batch schematic, disconnect the source clip from the source node.

To delete a source node:

- 1 Press **D** and click the source node in the Batch schematic.

Clearing Strokes on a Source

You can clear strokes from the canvas that were created using a source front or source matte.

WARNING Clearing strokes for an entire sequence cannot be undone.

To clear the strokes associated with a source:

- 1 In the Sources list, select the source used to create the strokes you want to clear.
- 2 From the Selection Mode box, select Current Frame or Sequence.



- 3 Click Clear Strokes.



Hiding Strokes

You can hide a group of strokes that were created from the same source clip.

Hiding strokes is useful when you need to focus on a particular component of your image: hide strokes on the canvas that do not require attention. This feature allows you to concentrate on the current stroke. It also improves the system's interactive performance.

To hide strokes on a source:

- 1 Select the source used to create the strokes that you want to hide.
- 2 In the Sources list, click Hide Strokes (**H**).



A check mark appears in the H column of each source.

- 3 Click Hides Strokes again to make the strokes visible.

Restricting Strokes with the Source Matte

You can limit the sections of the source that are painted onto the canvas using the source's matte. To limit painting on the canvas using the matte. See [Restricting Brush Strokes](#) on page 2389.

To limit source brush strokes using a source matte:

- 1 In the Paint Modes box, select Reveal (**E**).
- 2 In the Sources list, select a source.
- 3 From the source controls, select an option in the Matte Source box.

Select:	To:
Matte Off	Paint anywhere on the canvas.
Matte On	Limit painting to areas in the source matte.
Matte Invert	Invert the source matte and limit painting to areas outside the source matte.

4 Draw strokes.

Brush strokes only use areas of the selected source that are delimited by its source matte.

Locking Sources

Lock a source to a specific frame. For the duration of the clip, only the source front and source matte at the selected frame is used.

To lock a source:

- 1 Select the source you want to lock.
- 2 Using the playback controls, choose the frame at which you want to lock the clip.
- 3 In the Source Front option box, select Front Lock.

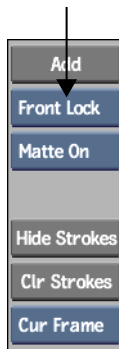

A check mark appears in the L column of each selected source.

- 4 In the Source Front option box, select Front On to unlock the source.

Displaying Sources

Batch Paint offers an intuitive way of previewing the effects of a Reveal operation. In this view, the selected source is superimposed over the result, and the Transparency field is activated to allow for transparency adjustments. This feature allows you to see exactly what your brush strokes will reveal. See [Previewing a Reveal Operation Using a Reference Image](#) on page 2402.

Brush Attributes and Attribute Modes

You can set various brush attributes and attribute modes to determine how paint is applied to the image.

Setting Brush Attributes

The Brush Attribute fields set the size of the brush, the distribution of the paint, and the rate and direction of the paint application.

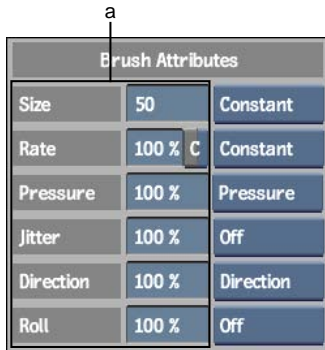

(a) Brush Attribute fields

Opacity Affects the transparency of the brush. A value of 100% applies a fully opaque colour. Use a lower value to apply a more transparent colour.

Size Determines the size of the brush, which is indicated by the diameter of the green dashed circle surrounding the cursor brush. To increase the brush size, press **S** and drag the brush to the right on the canvas. To decrease it, press **S** and drag to the left.

Rate Determines the rate at which brush strokes are applied to the canvas. Use a high value to produce a smooth continuous stroke, or a low value to produce a less continuous stroke with larger gaps between brush images. The C (Constant) button in the Rate field determines whether the consistency of the stroke is dependent on the speed at which you move the pen or mouse.

For example, to create a stroke of evenly spaced dots, you could set the Rate field to 20 percent and enable Constant.

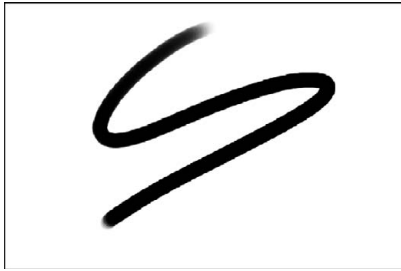

Rate attribute value = 100

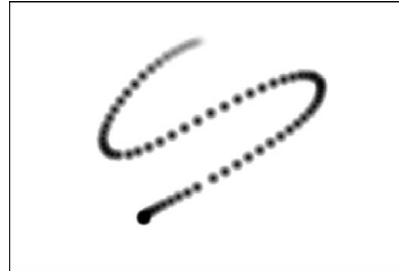

Rate attribute value = 25

Pressure Affects the transparency of the paint applied to the image. To apply opaque paint, use a high percentage value. For more transparent paint, use a low value. The Pressure attribute differs from the Opacity attribute in that you can set the Pressure attribute mode so that the paint transparency varies according to the pressure applied to the pen or the direction of the brush.



Pressure attribute value at 100%



Pressure attribute value at 50%

Jitter Randomizes the brush strokes applied to the image. A high value produces a greater dispersion of paint, while a low value produces a greater concentration.

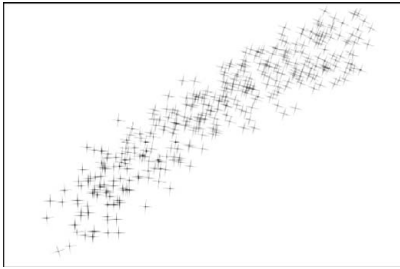

Jitter attribute value at 100%

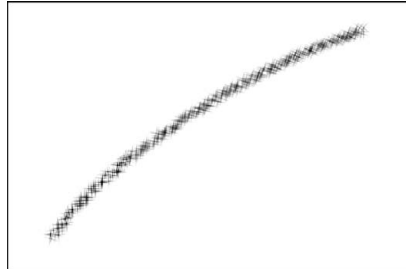

Jitter attribute value at 10%

Direction Causes the brush to rotate around the Z-axis and can be used to produce a calligraphy effect. The effect of the Direction attribute is most noticeable when used with one of the elliptical or star brushes. The value of the Direction attribute causes the brush strokes to rotate by 90 degrees for each increment of 25 percent.

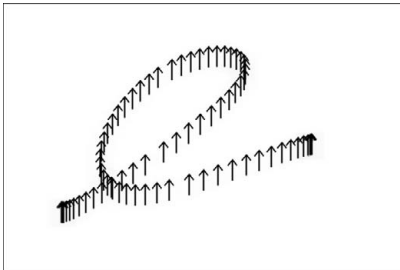

Direction attribute value at 100%

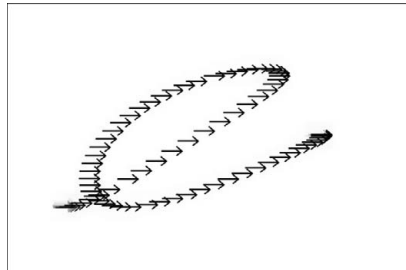

Direction attribute value at 75%

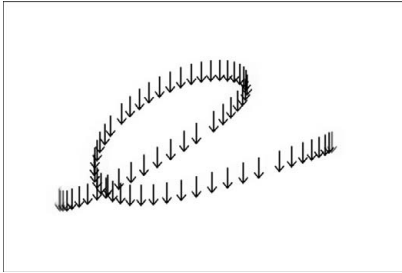

Direction attribute value at 50%

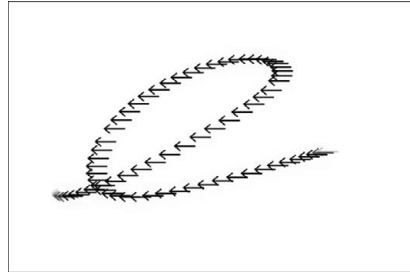

Direction attribute value at 25%

Roll Rolls the brush around the X-axis. The effect of the roll is most noticeable when used with one of the non-symmetrical brushes. For each increment of 25 percent, the Roll attribute value creates a rolled brush stroke of 90 degrees.

NOTE You can use any attribute mode with the Roll attribute.

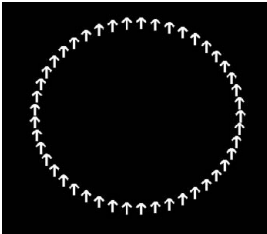

Roll attribute value at 100%

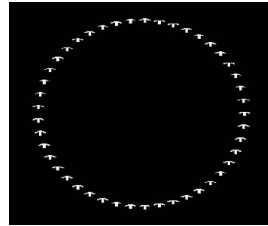

Roll attribute value at 75%

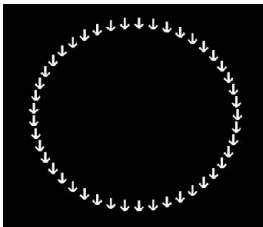

Roll attribute value at 50%

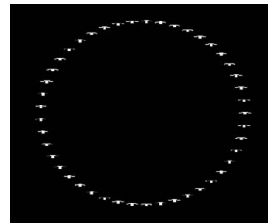

Roll attribute value at 25%

Setting Brush Attribute Modes

The value of a brush attribute depends on the selected attribute.

Brush Attributes		
Size	50	Constant
Rate	100 % C	Constant
Pressure	100 %	Pressure
Jitter	100 %	Off
Direction	100 %	Direction
Roll	100 %	Off

(a) Brush Attribute Mode boxes

Off Disables the brush attribute.

Constant Keeps the brush attribute values constant.

Pressure Uses the pressure exerted on the pen as the reference value. The harder you press on the pen, the greater the brush attribute value. The softer you press, the lower the brush attribute value.

Direction Uses the direction of the brush stroke as the reference. When used with the Direction mode, the Direction attribute causes the brush strokes to follow the trajectory of the brush. Increase the value to enhance the effect on brush direction. Drag right to use 100% of the brush attribute value, left to use 0%, up to use 25%, or down to use 75%.

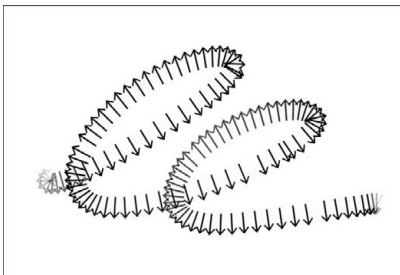

Direction attribute value at 100%, Direction attribute mode

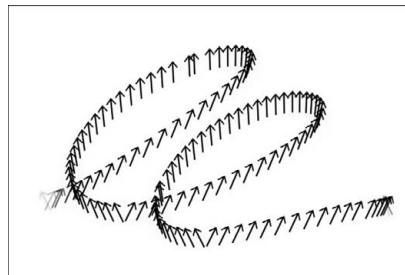

Direction attribute value at 15%, Direction attribute mode

Fade Uses the percentage value entered in the Fade field to determine the length of time that elapses before the brush stroke fades. The greater the percentage, the faster the stroke fades. A value of 100 in the Fade field causes the stroke to fade quickly, whereas a value of 1 causes the stroke to last longer. Also, strokes applied quickly will be longer than those applied more slowly.



Pressure attribute value at 100%,
Fade attribute mode at 35%

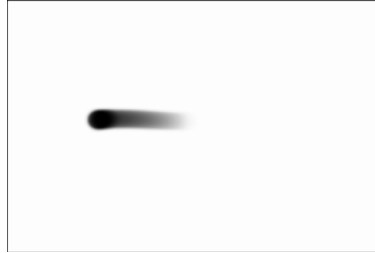

Pressure attribute value at 100%,
Fade attribute mode at 85%

Front, Matte, Source Front and Source Matte Allows you to use the red channel in a reference image to set brush attributes. Source Front and Source Matte mode use the red channel of the selected source in the Sources list.

Painting Brush Strokes

You can paint on the canvas using a variety of brush types and colours. Once you select a brush type, you can modify brush attributes to further refine your strokes. A stroke can be applied to a single frame, or simultaneously to multiple frames. You can paint on the result or output matte, or you can use matte paint mode controls to paint on the result and output matte at the same time.

You can restrict brush strokes to the area delimited by the matte. For example, assume that you have a front input that includes a person shot against a blue screen and a corresponding matte clip. If you opt to limit brush strokes to the matte, your brush strokes on the result or output matte appear only inside the matte area and, therefore, over the person. If you then limit brush strokes to the existing strokes, new paint strokes are applied only over strokes that have already been applied.

Applying Brush Strokes

As in the Paint module on the Flame, you can paint with either a pen or a mouse, and access various pressure settings.

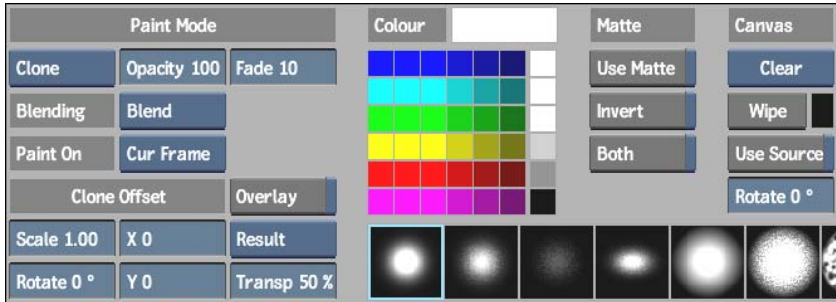

To apply a brush stroke:

- 1 Select an option from the Paint Tools box (or press **Q**).
- 2 Select an option from the Paint On box to apply the stroke to the current frame, all frames in the sequence, or the current frame and subsequent frames.
- 3 Select the Result (**F4**) or Output Matte (**F4 F4**) to set the view where you are painting.
- 4 If you want to paint on the result and output matte simultaneously, enable Both.
- 5 Click a brush to select it.

TIP Although you cannot create custom brushes in Batch Paint, you can do so in Paint module on the Flame and then switch back to Batch Paint to use them. See [Creating a Custom Brush](#) on page 2527.

- 6 Set brush attributes. See [Brush Attributes and Attribute Modes](#) on page 2382.
- 7 If you will reveal a source on the image, select the source in the Sources list. See [Revealing Sources](#) on page 2396.
- 8 To change the colour, click a colour pot. If you are painting on the output matte, the brush colour is grey with an equivalent luminance value.

TIP As an alternative to using the colour pots, you can designate the colour under the pointer as the current brush colour by pressing the left **Ctrl** key and clicking on the canvas.

- 9 Click and drag on the canvas to draw a stroke.

NOTE Downstream context views are not automatically updated as you add strokes, since this would cause performance degradation. To force an update, click the Update button or press **U**.

- 10 Use the eraser end of the pen if you are using the stylus to erase strokes that you have created.

Removing Brush Strokes

You can undo multiple brush strokes in Batch Paint. You can use the Undo button to remove brush stroke operations, beginning with the most recent strokes. Set Undo level operations in the Preferences menu.

If you are using a stylus, remove brush strokes manually by using the back of the stylus to “erase” strokes. If the result is displayed, erasing reveals the front clip on the canvas. If the output matte is displayed, erasing reveals the matte.

Restricting Brush Strokes

You can limit the area where brush strokes are applied on the canvas. Use the matte paint mode controls to limit painting on the canvas to the matte. You can also invert the matte to limit paint to only the areas outside the original matte.

To limit which regions of a source front can be used by its source matte, use the Matte Clip option box in the source controls. See [Restricting Strokes with the Source Matte](#) on page 2380.

To limit where brush strokes are applied using the matte:

- 1 Enable Use Matte.

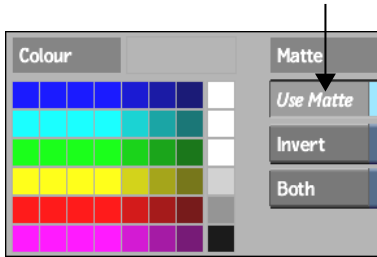

- 2 If you want to paint outside of your selection, enable Invert.
- 3 Draw strokes.
Brush strokes are applied only to the areas included in your selection.
- 4 Disable Use Matte to turn off matte restrictions.

Scaling Brush Strokes

You can set scaling options for brush strokes associated with the Paint node. By specifying the previous resolution of an input clip before it was resized, the brush strokes applied to the clip can also be scaled based on these settings.

To display the stroke scaling options:

- 1 Double-click the Paint node.
- 2 Click Node Setup.

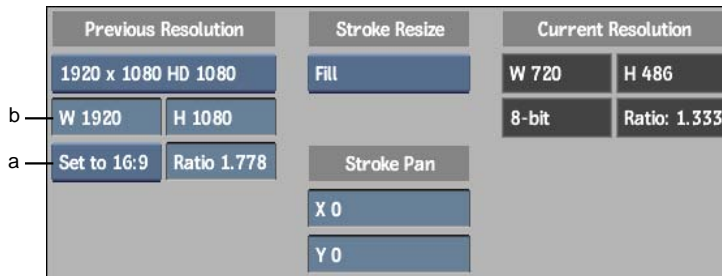

(a) Aspect Ratio Presets box (b) Project Resolution Presets box

Project Resolution Presets box Provides preset aspect ratio options and an option to use a custom resolution. Set this option to indicate the previous resolution of the clip.

Width and Height fields Displays the frame width and height of the selected resolution preset. If you select Custom from the Project Resolution Presets box, use these fields to enter the values you want to use.

Aspect Ratio Presets box Provides standard frame aspect ratio options and a w:h option to use a ratio based on the values entered in the Width and Height fields. Also provides a Custom option so you can enter a frame aspect ratio in the Ratio field.

Ratio field Displays the original aspect ratio of the clip. When Ratio is set to Custom, this field becomes active so that you can enter a custom frame aspect ratio.

Fit Method box Select a fit method option to be applied to the clip.

Select:	To:
Centre/Crop	Center the strokes over the destination frame. If the clip at the original resolution is larger than the destination, the strokes are cropped.
Crop Edges	Fit one edge of the original clip input into the destination frame without stretching or squashing the frame. Excess parts of the original clip after resizing are cropped.
Fill	Fit the original stroke width and height into the destination frame. If the clip at its original resolution and destination frames do not have the same aspect ratio, the brush strokes can become distorted.
Letterbox	Fit the original stroke to the destination frame without squashing or stretching it, and without cropping the source.

Keep Aspect button Enable to preserve the aspect ratio of non-square pixels. This button only appears if you selected Crop Edges or Letterbox in the Fit Method box.

Stroke Pan fields Enter an X and Y value to offset existing strokes on the result. You can also reposition strokes by holding down **Ctrl+Shift** and panning the image.

Current Resolution fields Displays details of the current resolution of the clip.

Using Paint Modes

You can select the type of special effects you want to apply to the brush from the Paint Modes box. Strokes applied with these brushes are processed by the graphics hardware, improving interactive performance. To paint sources onto images, see [Revealing Sources](#) on page 2396.

To select a brush:

- 1 Switch to either Result (**F4**) or Output Matte (**F4 F4**) view.
- 2 From the Paint Modes box, select a brush. Refer to the sections that follow for instructions on using each brush.

TIP When a brush is selected, brush opacity and blend modes are disabled. To achieve an effect similar to modified brush opacity, use the Pressure attribute mode.

Blur

Apply a blur filter to the image with each stroke.



Original image

After using the Blur brush

To use the Blur brush:

- 1 From the Paint Modes box, select Blur (**R**).
- 2 Set the brush size according to the size of the area you want to blur.
- 3 Paint on the image.

Impression

Paint on colours from a reference clip. When you click on the canvas, the colour at the center of the brush is used to fill the entire brush stroke.



Original image



After using the Impression brush

Image courtesy of Buzz Image Group, Inc., and Les Films Stupefiants

To use the Impression brush:

- 1 From the Paint Modes box, select Impression.
- 2 Set the brush size.
- 3 Paint on the image.

Smear

The Smear brush smudges areas of the image, creating a fingerprinting effect.



Original image



After using the Smear brush

To use the Smear brush:

- 1 From the Paint Modes box, select Smear (T).
- 2 Set the brush size according to the size of the area you want to smear.
- 3 Paint on the image.

Clone

Use the Clone tool to paint a copy of the result image to any position on the result image. The Clone tool can also be applied to an output matte image. For example, if the result image has a tree that you would like to copy to another position on the image, you can offset a copy of it to a different position and then paint it onto the result.

To paint a source onto the canvas, use the Reveal tool. See [Revealing Sources](#) on page 2396.

To clone an image and include cloned data in the brush strokes, use the Recursive Clone tool. See [Recursive Clone](#) on page 2395.

NOTE If changes are made upstream of the Paint node, cloned strokes are preserved. However, the strokes will reflect the “old” input unless you force an update by clicking the Update button or by pressing **U**. Updates are not performed automatically because they can affect system performance.

To clone an image:

- 1 Select Clone from the Paint Modes box (or press **W**).

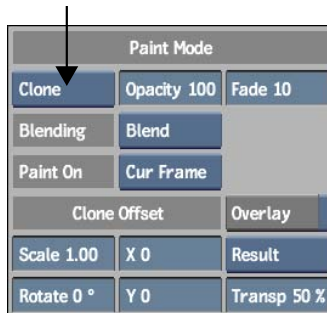

The Clone Offset parameters appear.

- 2 Set brush attributes. See [Brush Attributes and Attribute Modes](#) on page 2382.
- 3 To limit the cloned regions to the areas delimited by the matte, select an option in the Matte Source box.
- 4 To transform the reference image, do one of the following:
 - To manually offset the image, enable the Overlay button (**Tab**), then hold down **Ctrl+Shift** and drag the overlaid reference image.
 - To scale the image, enter a value in the Scale field.
 - To rotate the image, enter the angle of rotation in the Rotate field.

NOTE To select an area for cloning, Overlay must be turned off. If you offset an image, verify that the Overlay button is disabled after use.

- 5 To select the area you want to clone, press **Ctrl** and click the canvas. The cursor turns red when you press **Ctrl**. When you click the canvas, the red cursor is anchored and a green cursor appears.
- 6 Position the green cursor over the destination area and click the canvas. The green and red cursors are now locked into positions relative to each other and move in tandem.
- 7 To set precise coordinates for the clone offset, use the X and Y fields.
- 8 Click and drag on the canvas to clone to the destination area.

Recursive Clone

Use the Recursive Clone brush to paint the contents of the result image to another position on the result. Unlike the Clone tool, when brush strokes

created while using the Recursive Clone tool are used as a reference when the tool is applied elsewhere, the updated image data will be used.



Original image



After using the Recursive Clone medium

Image courtesy of Buzz Image Group, Inc., and Les Films Stupefians

To use the Recursive Clone brush:

- 1 From the Paint Modes box, select Recur Clone (Y).
- 2 Set the brush size according to the size of the area you want to clone.
- 3 To select the area you want to clone, press **Ctrl** and click the canvas. The cursor turns red when you press **Ctrl**. When you click the canvas, the red cursor is anchored and a green cursor appears.
- 4 Position the green cursor over the destination area and click the canvas. The green and red cursors are now locked into positions relative to each other and move in tandem.
- 5 To set precise coordinates for the offset, use the X and Y fields.
- 6 Paint on the image. The image contained within the red circle brush is copied to the region defined by the green circle.

Revealing Sources

The Reveal tool allows you to paint the contents of one or more source front images directly onto the result. You can also use the Reveal tool to copy source matte images onto the output matte. For example, if one source has a tree that you would like to include on the canvas, you can select the source with the tree and then paint it onto the result.

To paint with a copy of the result or output matte image, use the Clone tool. See [Clone](#) on page 2394.

NOTE If changes are made upstream of the Paint node, revealed strokes are preserved. However, the strokes will reflect the “old” input unless you force an update by clicking the Update button or by pressing **U**. Updates are not performed automatically because they affect system performance.

To reveal a front or matte input:

- 1 Select Reveal from the Paint Modes box (or press **E**).

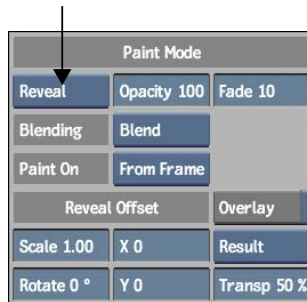

The Reveal Offset parameters appear.

- 2 Set the brush attributes. See [Brush Attributes and Attribute Modes](#) on page 2382.
- 3 In the Sources list, select the source you want to reveal.

NOTE You can reveal sources that are marked as hidden in the Sources list. You will only be able to view the strokes created with a source when you disable Hide Strokes.

- 4 To limit the revealed sources to the areas delimited by their mattes, select an option in the Matte Source box.
- 5 To display the source as an overlay of the result image, enable Overlay (**Tab**). You can apply transformations to the source before you apply strokes:
 - To interactively offset a source image, press **Ctrl+Shift** and drag the source. See [Previewing a Reveal Operation Using a Reference Image](#) on page 2402.
 - To scale the source, enter a value in the Scale field.

- To rotate the source, enter the angle of rotation in the Rotate field.
- 6 Click and drag on the canvas to apply strokes that reveal the transformed contents of the selected source.

Using Blending Modes

Blending modes are Boolean operations that can be applied to the brush's colour components. A mode is applied separately to each of the red, green, and blue components of images. You can apply blending modes to combine the RGB channels of corresponding pixels from a stroke, described as follows.

Lighten Increases the RGB channel values of each pixel of the brush stroke.

Darken Reduces the RGB channel values of each pixel of the brush stroke.

Exclusion Adds the RGB channel values of the brush stroke, then subtracts twice the product of these channels.

Hard Light Multiplies or screens the selected colour of the brush stroke onto the image, depending on the colour. The effect is similar to shining a harsh spotlight on the image, and greatly reduces the contrast levels in the image.

If the blend colour (light source) is lighter than 50% grey, the image is lightened as if it were screened—this is useful for adding highlights to an image. If the blend colour is darker than 50% grey, the image is darkened, as if it were multiplied—this is useful for adding shadows.

Multiply Multiplies the RGB channel values of corresponding pixels of the stroke and the current image and normalizes the result by dividing by 255 in 8-bit mode, or 4095 in 12-bit mode. The resulting RGB channel values are assigned to the corresponding pixels in the generated clip.

Divide Divides the RGB channel values of pixels of the stroke and the current image and normalizes the result by multiplying by 255 in 8-bit mode, or 4095 in 12-bit mode. The resulting RGB channel values are assigned to the corresponding pixels in the generated clip.

Overlay Multiplies or screens the colours, depending on the RGB channel values of the colour of the stroke and the current image. Patterns or colours overlay the existing RGB channel values while preserving the highlights and shadows of the stroke's colour. The colour of the stroke is not replaced, but is mixed with the colour of the current image to reflect the lightness or darkness of the original colour.

Screen Multiplies the inverse of the current image with the colour of the brush stroke. The resulting colour is always lighter. The colour remains unchanged when you screen with black. Screening with white produces white. The effect is similar to projecting multiple photographic slides on top of each other.

Soft Light Shines a soft, diffuse light on the image. If the blend colour (light source) is lighter than 50% grey, the image is lightened. If the blend colour is darker than 50% grey, the image is darkened.

Using this mode with a black brush stroke results in a very dark effect; with white, a very bright one.

Add Adds the luma values of corresponding pixels of the brush stroke and the current image. The resulting value is assigned to the corresponding pixels in the generated clip. If the result is greater than 255 (in 8-bit mode), the pixel in the destination clip is clamped at a value of 255 (white). In 12-bit mode, the maximum colour value is 4095. The resulting clip is always brighter.

Subtract Subtracts the RGB channel values of the pixels of the current image from the RGB channel values of the pixels of the brush stroke and assigns the result to the RGB channel values of the pixel.

If an RGB channel value of the current image is larger than the corresponding channel value of the brush stroke, yielding a negative result, that result is clamped at 0 (black). The resulting clip is always darker.

To blend a stroke with the current image:

- 1 Select a Blend mode from the Blend option box.

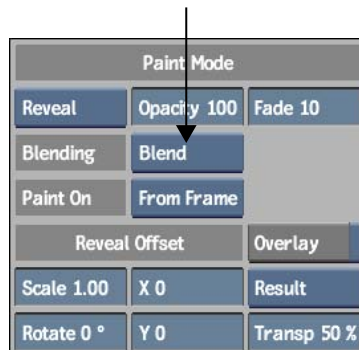

- 2 Select a brush and colour.
- 3 Draw a stroke.

The stroke with the selected blend is applied. The current blend mode only affects new strokes. However, if you draw over existing strokes, the blend is created using the pixel values for the two different strokes.

Using the Canvas

Use the canvas controls to control clearing and wiping of the image.

Clearing the Canvas

You can clear all strokes from the result image and output matte at the current frame or all frames. To limit the operation to a source, see [Clearing Strokes on a Source](#) on page 2378.

WARNING Any strokes that have been applied will not be maintained when you clear strokes.

To clear strokes from the canvas:

- 1 Select one of the following from the Clear Canvas option box:
 - Clear to remove strokes from the current frame.
 - Clear All to remove strokes from all frames.



(a) Clear Canvas option box

The strokes are removed from the result image.

Wiping the Canvas

You can wipe the result image when you want to apply a uniform colour at the current frame in a single brush stroke. Alternatively, you can use a source, to wipe over an image.

To wipe the result image with a colour or a source:

- 1 From the View box, select Result (**F4**).
- 2 Do one of the following:
 - Pick the wipe colour by clicking the colour pot to the right of the Wipe button. See [Picking Colours](#) on page 71.
 - Select the source in the Sources list and enable Use Source.

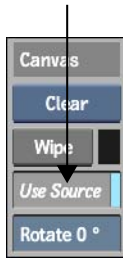

- 3 To display the source as an overlay of the result image, enable Overlay (**Tab**). You can apply transformations to the source before you apply the wipe:
 - To interactively offset a source image, press **Ctrl+Shift** and drag the source. See [Previewing a Reveal Operation Using a Reference Image](#) on page 2402.
 - To scale the source, enter a value in the Scale field.
 - To rotate the source, enter the angle of rotation in the Rotate field.
- 4 Click Wipe.

Rotating the Canvas

During the painting process, you can rotate the canvas, making it easier to paint on any part of your image.

To rotate the canvas:

- 1 Do one of the following:
 - Set the angle of rotation in the Rotation field.
 - Press **Alt+spacebar** and drag in your image.



(a) Rotation field

Previewing a Reveal Operation Using a Reference Image

Overlaying a reference image on the result offers an intuitive way of previewing paint operations.

When you overlay a source onto the result, you can preview the effects of a Reveal operation. The selected image is superimposed over the result, and the transparency can be adjusted. This allows you to see exactly what your brush strokes will reveal.

When you overlay a result reference clip onto the result, you can slip the overlaid frame to display previous or next frames, creating an onion skin effect.

The overlay of the front and the matte can also be shown on the result, allowing you to rotoscope more easily, for example.

To display the reference image:

- 1 Enable the Overlay button (**Tab**).

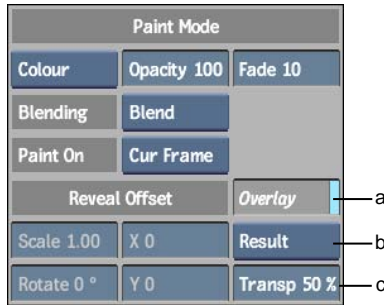

(a) Overlay button (b) Reference button (c) Transparency field

The reference image appears by default at 50% transparency.





- 2 Select the reference image you want to display from the Reference box.
- 3 If you selected Source Matte or Source Front, select an image from the Sources list.
- 4 With the reference image, you can:
 - Hold down **Ctrl+Shift** and drag the source front or source matte to offset it to preview a Reveal operation.
 - Scale the image, by entering a value in the Scale field.
 - Rotate the image, by entering the angle of rotation in the Rotate field.
 - Set the Slip value in the Sources list to show a reference image at a different frame relative to the actual frame position. See [Slipping a Reference Image](#) on page 2403.
 - Set the transparency for the reference image in the Transparency field.

NOTE You can also drag the result image to offset it for a Clone operation by holding down **Ctrl+Shift**.

Slipping a Reference Image

A reference image that is offset in time can be overlaid on the canvas. You can slip a front, matte, result, output matte, source front, and source matte clips. In the Sources list, use the Slip field to indicate the offset amount.

Each slip value can be set independently. To set the same front and matte values for a source, hold down the **Alt** key and edit either value.

Front		Slip	Matte	Slip		L	H
	LayerFront	0		LayerMatte	0		
	silk	0		silk	0		

(a) Front and Source Front Slip fields (b) Matte and Source Matte Slip fields

Saving Setups and Preferences

Batch Paint setups are saved as XML files with the *.bpaint* extension. The procedures for saving and loading Batch Paint setups are the same as for other setups. See [Loading a Node's Setup](#) on page 1311.

Topics in this chapter:

- [About Paint](#) on page 2405
- [Loading Clips into Paint](#) on page 2406
- [Locking and Unlocking the Duration of a Clip](#) on page 2408
- [Using the Mouse](#) on page 2408
- [Displaying a Reference Image](#) on page 2408
- [Using Grids and Guides](#) on page 2409
- [Selecting Colours](#) on page 2411
- [Previewing an Animation](#) on page 2414
- [Painting on Full-Resolution Film Images](#) on page 2415
- [Saving and Restoring the Image](#) on page 2416

About Paint

Use the Paint tools to create graphics, paint on images, and retouch clips. Use a matte to protect areas of the front clip during painting. Record, animate, and apply a series of brush strokes to a clip. Use the Graphic and Cut/Paste tools to create rotoscoped sequences and shape animations.

Loading Clips into Paint

When accessing Paint, you first select the clips that you want to use. Any of the following combinations of clips can be used in Paint:

- A front clip only
- A front clip and a back clip
- A front clip and a matte clip
- A front clip, a back clip, and a matte clip
- None (a blank canvas)

The front clip appears on the Paint canvas, which you can use to apply colours and effects to the clip. The matte clip delimits the area of the front clip affected by painting. The back clip can be revealed or brushed through onto the front clip. The colour of the blank canvas is defined by the wipe colour.

NOTE The image window in Paint is referred to as the *canvas* in the following sections.

To load clips into Paint:

- 1 In the Main menu, click Effects, and then Paint.
The Input Mode box appears.
- 2 Select an option other than None from the Input Mode box.
- 3 Select the source clips.
- 4 Select the destination reel.
The Paint menu appears.



5 Access one of the following Paint menus.

Click:	To:
Paint	Use the brushes or geometric shapes to paint on the canvas, record and apply strokes to the canvas, fill areas of the image with a reference colour or image, and move the image on the canvas.
Graphics	Create, edit, and animate shapes and apply them to the canvas.
CutOut	Create and add effects to cutouts and apply them to the canvas.
Setup	Set preferences, rendering options, grid guides, and colour correction options.

To access the Paint menu with a blank canvas:

- 1 In the Main menu, click Effects, and then Paint.
The Input Mode box appears.
- 2 From the Input Mode box, select None.
The resolution controls appear.
- 3 Choose a resolution, width, height, pixel aspect ratio, bit depth, and scan mode to apply to the background in Paint. See [Resize Settings](#) on page 681.
- 4 Set the frames per second and drop-frame values for the clip from the Frame Code Mode box.

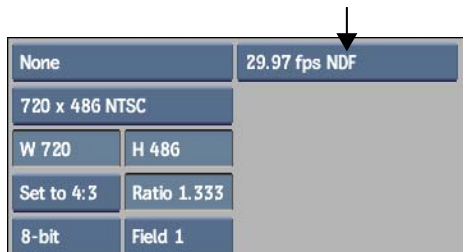

- 5 Select the destination reel.

Locking and Unlocking the Duration of a Clip

You can determine whether or not frames are added to the end of a clip.

To add frames to the end of the clip:

- 1 Click Setup.
- 2 Enable Extend Clip.



- 3 Click Next Frame.

A frame is added. You can continue to add frames in the same manner with Extend Clip enabled.

TIP To maintain the length of the original clip, disable Extend Clip. No frames are added to the clip when you click Next Frame.

Using the Mouse

You can use either the mouse or the tablet and pen to paint. Press and hold the right mouse button to apply paint at 80% pressure, the middle button to paint at 40% pressure, and the left button to paint at 20% pressure.

Displaying a Reference Image

You can display a reference image in the background of the result image to use as a guide for rotoscoping.

To display the reference image:

- 1 Enable the Show button.

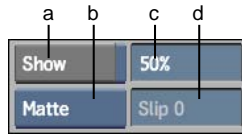

(a) Show button (b) Reference box (c) Transparency field (d) Slip field

The reference image appears by default at 50% transparency.

- 2 Select the reference image you want to display from the Reference box.
- 3 Set the transparency for the reference image in the Transparency field.
- 4 Set the Slip field value to show different images from the reference clip. This option only works if the reference image you selected is from a clip with more than one frame.

NOTE The Slip field is disabled if you select Matte or Saved from the Reference box.

Using Grids and Guides

Use the Grid/Guides button to set up reference points when painting and to accurately place strokes on the image.

Use the field guides to provide reference points when painting, and the grid to help you accurately place strokes on the image. Neither the field guides nor the grids appear on the processed clip.

The Grid and Guides menu contains the Safe area guide controls, the Grid controls, and the Centre controls.



The Safe area guide controls and Centre controls are subsets of their corresponding controls in the Grid and Guides menu in the other modules. See [Working with Grids and Guides](#) on page 116.

Grid Controls

You can set the behaviour of the grid so that paint strokes snap or lock to points on the grid. Use the Grid controls to configure the appearance and behaviour of the grid.

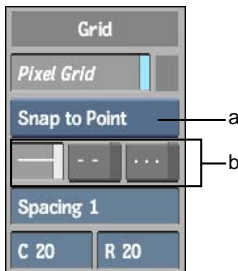

(a) Grid Behaviour box (b) Style buttons

To toggle the grid on and off, click Pixel Grid. When Pixel Grid is on, use the following controls to configure the appearance and behaviour of the grid.

Grid Behaviour box Displays the behaviour of the grid with respect to paint strokes:

- Snap to Point snaps each point of a stroke to the nearest intersection of a horizontal and a vertical grid line.
- Snap to Line snaps the current point of a paint stroke to the nearest point on a horizontal or vertical grid line.

- Lock to Point locks each point of a paint stroke to the nearest intersection of a horizontal and a vertical grid line.
- View uses the grid without the snap to or lock to options.

Style buttons Set a style for the lines of the grid. The style is either a solid line, a dashed line, or a dotted line.

Spacing field Sets the number of pixels between the dashes in a dashed line style, or between the dots in a dotted line style.

C, R fields Set the number of columns and rows respectively in the grid.

Resetting the Grid and Guides

Use the Reset All button in the lower-right corner to reset the grid and all guides to their default values.

Using the Player in the Paint Module

You can access the Player from the Paint module. To do so, click Process in the Paint module and then click Play once the clip is processed. Each time you access the Player, a clip is created on the Desktop. This clip cannot be removed from the Paint module. You must delete it from the Desktop instead.

Selecting Colours

In Paint, you select colours using the colour picker. You store colours in the colour palette, mix or try out colours on the scratch pad, and create colour or greyscale gradients using the colour gradient.

Using the Current Colour

The current colour is used when you paint. It is also used to set the colour for the wipe function and the matte colour. Select the current colour from the colour palette, scratch pad, or colour gradient. Or, click the Current Colour pot to use the colour picker. See [Picking Colours](#) on page 71.

Using the Colour Palette

The colour palette appears in the Paint, Graphics, and CutOut menus. It contains the scratch pad and colour gradient. A series of colours are stored in the colour palette in colour pots. To select the current colour in the colour palette, click a colour pot. To set the current colour, press and hold a colour pot.

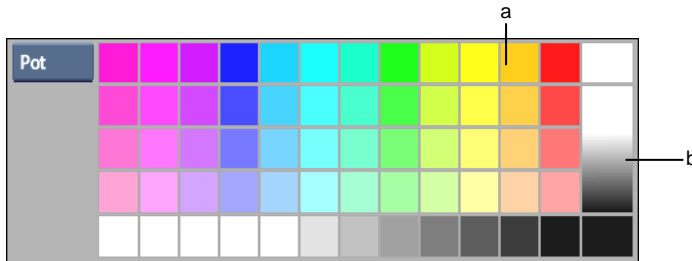

(a) Colour pot (b) Colour gradient bar

Build your own colour palette by storing the current colour in the colour pots. You can also save and load colour palettes. See [Paint: Setups](#) on page 2523.

To store a colour in the colour palette:

- 1 To display the colour palette, swipe the bar at the bottom of the screen. The colour palette appears.

TIP If you do not see the palette, click the Palette button. To hide it, swipe the bar a second time.

- 2 Set the current colour.
- 3 Click a colour pot in the colour palette and hold the cursor down momentarily. The colour is saved in the colour pots.

Using the Scratch Pad

Use the scratch pad to mix colours selected from the image or colour pots and to test the selected brush type. You can also paste cutouts into the scratch pad to use when mixing colours.

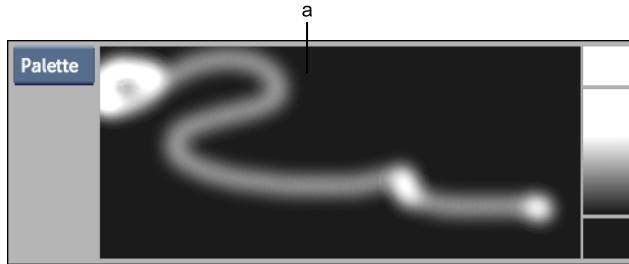

(a) Scratch pad

To mix colours on the scratch pad:

- 1 Click the Pot button.
The scratch pad appears.
- 2 Paint on the scratch pad.
- 3 Change the current colour and paint over the previous brush strokes.
The colours are mixed.

You can also use the Wash, Shade, Smear, Drag, Warp, Impressionist, Recursive Clone, Stamp, and Blur Special Effects media in the scratch pad.

To use one of the media types in the scratch pad:

- 1 Select the Special Effects medium you want to use. See [Using Filters and Special Effects Media](#) on page 2437.
- 2 Enable Medium.
- 3 Use the brush cursor to apply the medium in the scratch pad.

To set the current colour using the scratch pad:

- 1 Click the Current Colour pot.
- 2 Use the colour picker to select the mixed colour in the scratch pad.
- 3 Click the Current Colour pot to use the selected colour.

Using the Colour Gradient Bar

The colour gradient bar is used to set the gradients for graphics you create in the Graphics menu. See [Using Graphics in Paint](#) on page 2475. You can also set the current colour by selecting a colour on the gradient using the colour picker.

To set the gradient:

- 1 Set the current colour.
- 2 Click either the upper or lower colour pot on the gradient bar.

NOTE You must hold the cursor down for a moment to set the Gradient colour pot.

To set the current colour using the colour gradient bar:

- 1 Click and drag the cursor across the gradient bar.
The selected colour appears in the Current Colour pot.
- 2 Select a colour.
The selected colour becomes the current colour.

Previewing an Animation

Use the Flipbook command to preview an animation by playing a sequence of either five or nine frames.

To set up the Flipbook command:

- 1 Click Setup.
The Setup menu appears.
- 2 In the Flipbook area, select an animation mode from the Flipbook box.

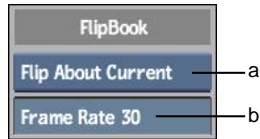

(a) Flipbook box (b) Frame Rate field

Select:	To:
Flip About Current	Play two (or four) frames before the current frame and two (or four) after the current frame. This is the default setting.
Flip From Current	Play five (or nine) frames beginning at the current frame.
Flip To Current	Play five (or nine) frames ending at the current frame.

- 3 Enter the frame rate in the Frame Rate field.

NOTE If the system is running at high resolution, it may not be able to achieve a flip rate of 30 frames per second.

- 4 Press **F** to play five frames, or press **Shift+F** to play nine frames.
If you selected Flip About Current, pressing **F** plays two frames before and after the current frame. Pressing **Shift+F** plays four frames before and after the current frame.

Painting on Full-Resolution Film Images

Use the Zoom Mode box to paint on a film resolution image at full resolution from a zoomed out perspective. With this feature, you can perform complex operations like full-frame rotoscoping without having to constantly zoom in and out from the image on which you are painting.

In the Paint menu, the Zoom Mode box shows the zoom mode in which you are working. This mode is set automatically. If you zoom out from the image, the Zoom mode automatically switches from Raster to Tiled. This allows you to paint on the image from a zoomed out perspective.



(a) Zoom Mode box

NOTE If you manually switch the zoom mode to Raster while zoomed out from the image, you will not be able to paint on it.

You can also manually select either Raster or Tiled mode if you want to override the default mode. In Raster mode, if you apply paint to the edge of the image while zoomed in, the paint is applied in an abruptly sharp straight edge along the border of the canvas; the brush stroke is not completed on the image. In Tiled mode, if you attempt the same operation, the paint is applied from the full diameter of the brush you are using to the area of the image that is not visible on the canvas.

Saving and Restoring the Image

You can save the current frame on the canvas. If you want to reverse a paint application, you can restore the image without having to recreate it.

Save (Image Buffer) Saves the image that currently appears on the canvas. A single frame is stored in the Save buffer. The next time you click Save, the current frame replaces the frame stored in the Save buffer.

Restore Replaces the current image on the canvas with the contents of the Save buffer.

Preview Displays the contents of the Save buffer. Select the Saved option in the Reference box and click and hold Preview to view the contents of the Save buffer.



(a) Reference box

Exiting Paint

When exiting Paint, you may keep or discard the changes you have made to the front clip. Click Exit and select an option.

Select:	To:
Exit	Keep the changes you made to the front clip. The modified front clip appears on the destination reel.
Keep One	Keep only the current frame of the front clip. When this option is selected, a Confirm button appears to the right of the canvas. Click Confirm to keep only the current frame of the front clip. The current frame appears on the destination reel.
Cancel	Quit Paint without saving changes to the front clip. When this option is selected, a Confirm button appears to the right of the canvas. Click Confirm to quit without saving your changes, or click elsewhere to cancel.

Topics in this chapter:

- [About Canvas Mode](#) on page 2419
- [Selecting a Brush](#) on page 2420
- [Rolling the Image](#) on page 2421
- [Painting with Geometry](#) on page 2422

About Canvas Mode

When you first open Paint, you are in Canvas mode. In Canvas mode, you can use brushes to modify your images. Brushes apply colour, filters, and Special Effects media to the image on the canvas. The brush cursor appears as a green cross surrounded by a circle when placed over the canvas. Canvas mode features are not available from multiple menus, such as Canvas, Geometry, Fill, and Roll.

You can also paint on the canvas using geometric shapes to define the path of the brush.

To ease the painting of canvas edges, you can roll the canvas in the image window.

To paint on the canvas:

- 1 Click Paint.

The Paint menu appears.

- 2 Click Canvas.
If the scratch pad is covering this button, swipe down to hide the scratch pad.
- 3 From the Paint Mode controls, click Paint.
- 4 Set a colour in the Current Colour pot. See [Selecting Colours](#) on page 2411.
- 5 Select a brush from the Brushes window. See [Selecting a Brush](#) on page 2420.
- 6 Set the brush attributes and modes in the Brush Attributes fields. See [Brush Attributes](#) on page 2428 and [Brush Attribute Modes](#) on page 2433.
- 7 Set the brush opacity in the Opacity field. Set the opacity to 100% to apply a fully opaque colour.
- 8 Stroke the brush over the canvas. To paint straight horizontal and vertical lines, press **Shift** and drag the brush up and down or left and right.
- 9 Click Undo (or press **Ctrl+Z**) to erase the strokes applied to the canvas since the last time you zoomed, panned, or changed a brush attribute.

Selecting a Brush

A number of predefined brush types are available in Paint including round, square, and elliptical brushes of various sizes and edge softness. The cursor has the same appearance regardless of which brush type you use. Each brush has its own icon in the Brushes window. The white portions of the brush icon indicate where the paint will be applied on the image.

See [Creating a Custom Brush](#) on page 2527.

To select a brush:

- 1 Scroll through the Brushes window.

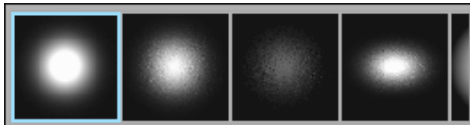

To scroll the selections, click the Brushes window and drag left or right.

- 2 Click the brush icon you want to use.
The selected brush is highlighted by a blue outline.

NOTE Only one brush can be active at a time.

Using the Large Canvas

In Large Canvas mode, almost the entire image window is available for painting, but not all Paint options are available. You can still change the brush characteristics, medium, and show options. You can also save, restore, and wipe the canvas.

To display the large canvas:

- 1 Click Paint.
- 2 Click Canvas.
- 3 Swipe your cursor anywhere on the right edge of the screen, or press **Esc** to toggle between the large canvas and Paint menu.

Rolling the Image

Use the Roll menu to reposition the current frame on the canvas to paint its edges.

To roll the image:

- 1 Click Paint.
- 2 Click Roll.
The Roll menu appears.

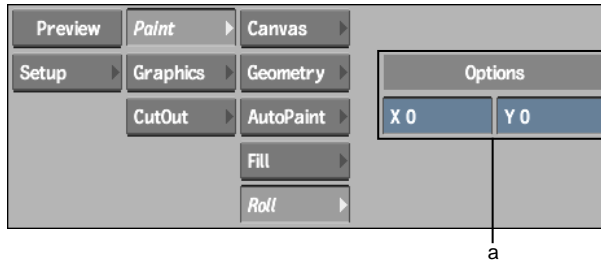

(a) Coordinate fields

- 3 Zoom in on the image if necessary.
- 4 Drag the image using the pan cursor.
You can also enter the roll values in the Coordinate fields.
- 5 To recentre the frame, click Reset.

NOTE The frame is automatically recentred when you go to another frame or exit Paint.

Painting with Geometry

Use the Geometry feature to draw lines, rectangles, circles, and triangles on the canvas.

Painting with geometry is different from drawing objects in Graphics mode. In Graphics mode, you create objects that can be edited. When you paint with geometry, you define paths for the brush to follow. Paint uses the current brush setup to apply the stroke to the canvas.

Painting Lines

Use the Line option to paint straight lines. Paint single lines one at a time, or draw connected multiple lines. You can constrain the lines to vertical or horizontal paths or specific angles.

To paint a line or multiple lines:

- 1 Click Geometry to display the Geometry menu.

- 2 Select Line from the Geometry box.
The Multiple Line button and the Line Type box appear.

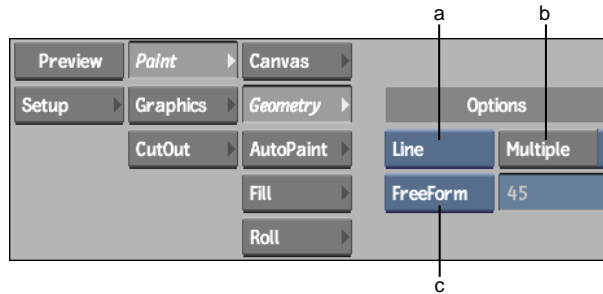

(a) Geometry box (b) Multiple button (c) Line Type box

- 3 Select the type of line you want to draw from the Line Type box.

Select:	To:
Angle	Paint a line at a specific angle. This option displays a field in which you enter the angle in degrees.
Vertical	Paint vertical lines.
Horizontal	Paint horizontal lines.
FreeForm	Paint lines at any angle with no constraint.

- 4 If you selected Angle, enter a degree in the field.
- 5 To draw single lines, move to the canvas and click, drag, and release.
A brush stroke is painted along the line.
- 6 To draw multiple lines, enable Multiple, move to the canvas, and click to place the start point of the first line. Click again to draw the end point. Continue clicking to place additional points and draw more lines.
- 7 To end multiple lines, click below the timebar or on the menu panel to turn the option off.
The brush strokes are painted along the lines.

Painting Rectangles

Use the Rectangle option to draw rectangles or squares.

To paint a rectangle or square:

- 1 Click Geometry to display the Geometry menu.
- 2 Select Rectangle from the Geometry box.
The Equal Sides button appears.

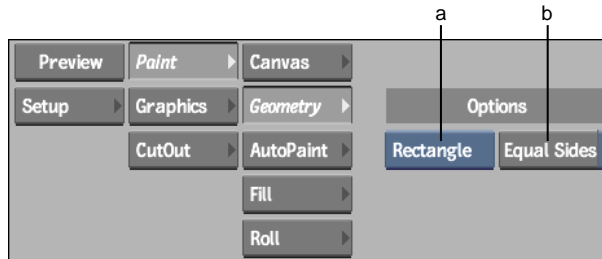

(a) Geometry box (b) Equal Sides button

- 3 To draw a square, enable Equal Sides or press and hold **P**.
- 4 Press the cursor on the canvas to anchor the first corner of the rectangle.
Drag the cursor to size the rectangle.
- 5 When the rectangle is the required size, release the cursor.
A brush stroke is painted along the sides of the rectangle.

Painting Circles

Use the Circle option to draw circles of any size.

To paint a circle:

- 1 Click Geometry to display the Geometry menu.
- 2 Select Circle from the Geometry box.
- 3 Press the cursor on the canvas to anchor the centre point of the circle.
Drag the cursor to size the circle.
- 4 When the circle is the required size, release the cursor.

A circular brush stroke is painted.

Painting Triangles

Use the Triangle option to draw equilateral or asymmetric triangles.

To paint a triangle:

- 1 Click Geometry to display the Geometry menu.
- 2 Select Triangle from the Geometry box.
The Equal Sides button appears.

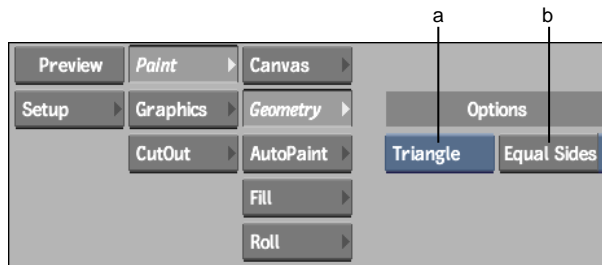

(a) Geometry box (b) Equal Sides button

- 3 To draw an equilateral triangle, enable Equal Sides or press and hold **P**.
- 4 Move to the canvas and click to anchor the first vertex of the triangle.
- 5 Click to place the second vertex and then again to place the third vertex.
If you are drawing an equilateral triangle, drag the cursor until the triangle is the required size.
A brush stroke is painted along the sides of the triangle.

Setting Brush Attributes and Modes

83

Topics in this chapter:

- [About Brush Attributes and Modes](#) on page 2427
- [Brush Attributes](#) on page 2428
- [Brush Attribute Modes](#) on page 2433
- [Preferences Affecting Brushes](#) on page 2435

About Brush Attributes and Modes

You can set various brush attributes and attribute modes that determine how paint is applied to the image. Each brush attribute has a corresponding Attribute Mode control. You use the Preferences menu to affect the way paint is applied to the image.

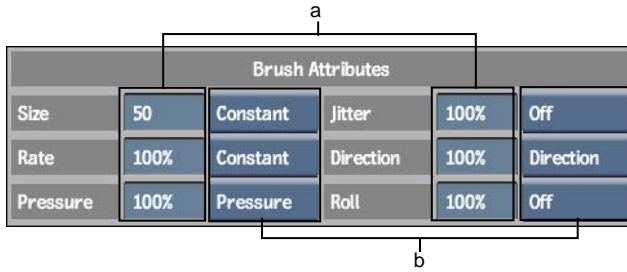

(a) Brush Attribute fields (b) Attribute Mode controls

In the Paint menu, the Brush Attributes and Attribute Mode controls share the same space as the colour palette. To display the brush attributes and modes in the Paint menu, swipe the cursor at the bottom of the screen.

In the Graphics Edit menu, the Brush Attributes and Mode controls appear only when the object attribute is set to Outline or Fuzzy. To display the brush attributes and modes in the Graphics menu, swipe the cursor twice at the bottom of the screen.

NOTE The brush attribute and attribute mode values set in the Paint menu are independent from the values set in the Graphics menu.

Brush Attributes

The Brush Attribute fields set the size of the brush, the distribution of the paint, and the rate and direction of the paint application. Brush attributes are listed as follows:

- Size
- Rate
- Pressure
- Opacity
- Jitter
- Direction
- Roll

Brush Opacity

The brush opacity affects the transparency of the brush. A value of 100% applies a fully opaque colour. Use a lower value to apply a more transparent colour. Enter a value in the Opacity field.

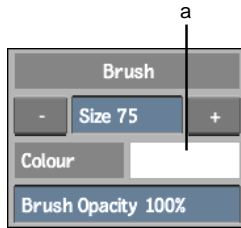

(a) Current Colour field

NOTE You can only use the Front, Back, Result, and Saved attribute modes with the Opacity attribute.

Brush Size

The brush size is indicated by the diameter of the green dashed circle surrounding the cursor brush. To increase the brush size, set a value in the Size field, or press **S** and drag the brush to the right on the canvas. To decrease it, press **S** and drag to the left.

You can also use the Size buttons to increase or decrease the brush size. Click the + button to increase the brush size. Click the - button to decrease the brush size. You can also click and drag in the Size field or click and enter a value.

NOTE You can use any attribute mode with the Size attribute.

Brush Rate

The brush rate is the rate at which brush strokes are applied to the canvas. Use a high value to produce a smooth continuous stroke, or a low value to produce a less continuous stroke with larger gaps between brush images.

NOTE You can use any attribute mode with the Rate attribute.

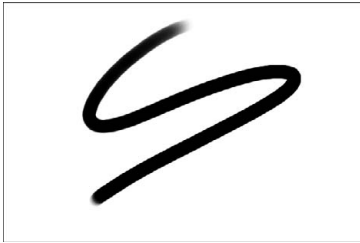

Rate attribute value = 100

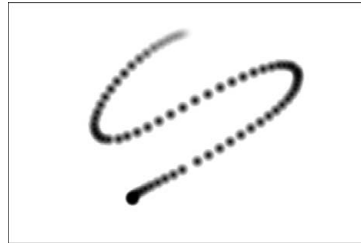

Rate attribute value = 25

Brush Pressure

The brush pressure affects the transparency of the paint applied to the image. To apply opaque paint, use a high percentage value. For more transparent paint, use a low value.

The Pressure attribute differs from the Opacity attribute in that you can set the Pressure attribute mode so that the paint transparency varies according to the pressure applied to the pen or the direction of the brush.

NOTE You can use any attribute mode with the Pressure attribute.



Pressure attribute value at 100%



Pressure attribute value at 50%

Brush Jitter

The Jitter attribute randomizes the brush strokes applied to the image. A high value produces a greater dispersion of paint, while a low value produces a greater concentration.

NOTE You can use any attribute mode with the Jitter attribute.

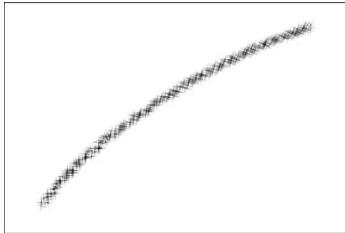

Jitter attribute value at 10

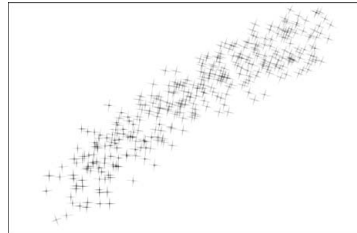

Jitter attribute value at 100

Brush Direction

The Direction attribute causes the brush to rotate around the Z-axis and can be used to produce a calligraphy effect. The effect of the Direction attribute is most noticeable when used with one of the elliptical or star brushes. The value of the Direction attribute causes the brush strokes to rotate by 90 degrees for each increment of 25 percent.

NOTE You can use any attribute mode with the Direction attribute.

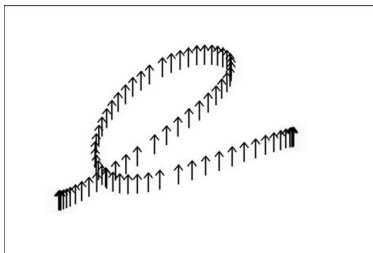

Direction attribute at 100%

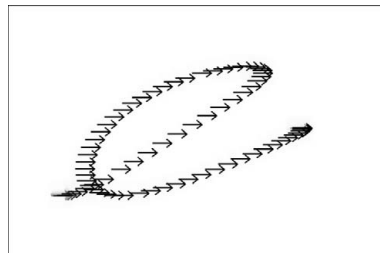

Direction attribute at 75%

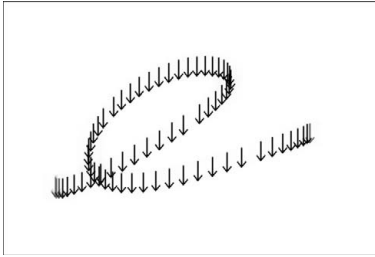

Direction attribute at 50%

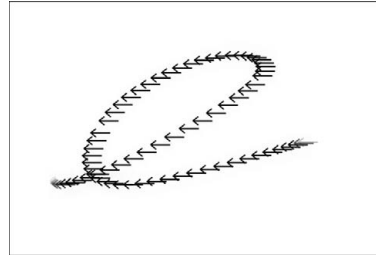

Direction attribute at 25%

Brush Roll

The Roll attribute rolls the brush around the X-axis. The effect of the roll is most noticeable when used with one of the non-symmetrical brushes. For each increment of 25 percent, the Roll attribute value creates a rolled brush stroke of 90 degrees.

NOTE You can use any attribute mode with the Roll attribute.

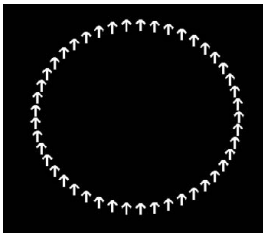

Roll attribute value at 100%

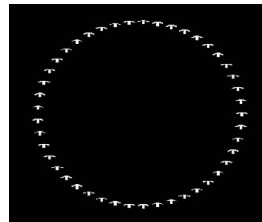

Roll attribute value at 75%

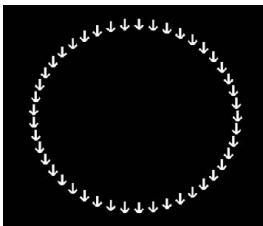

Roll attribute value at 50%

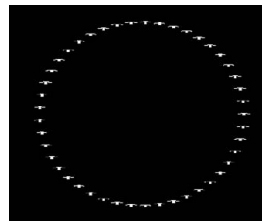

Roll attribute value at 25%

Brush Attribute Modes

The value of a brush attribute depends on the selected attribute mode. You can choose Constant, Off, Front, Back, Result, Saved, Pressure, or Direction.

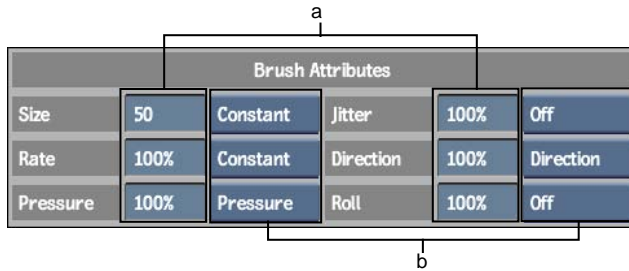

(a) Brush Attribute fields (b) Attribute Mode controls

In Constant mode, the brush attribute values remain constant. In Off mode, the attribute is disabled.

The Front, Back, Result, and Saved modes use the colour values in a reference image to vary the brush attribute value. Pressure and Direction modes affect how paint is applied by causing the brush attribute value to vary in relation to the pressure exerted on the pen and the direction of the brush, respectively.

NOTE Do not set the Size, Rate, or Pressure attributes to Off mode.

Using Reference Images

The Front, Back, Result, and Saved modes use the red channel in reference images to set the brush attribute values. Front mode uses the front clip as the

reference, Back mode uses the back clip, Result mode uses the result clip, and Saved mode uses the image in the Save buffer.

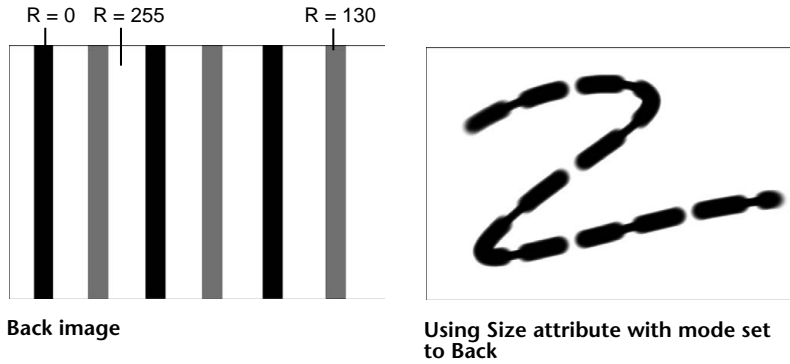

Direction of the Brush

The Direction mode uses the direction of the brush stroke as the reference.

When used with the Direction mode, the Direction attribute causes the brush strokes to follow the trajectory of the brush. Increase the percentage value to enhance the effect on brush direction.

Drag:	To:
Right	Use 100% of the attribute value.
Left	Use 0% of the attribute value.
Up	Use 25% of the attribute value.

Drag:

To:

Down

Use 75% of the attribute value.

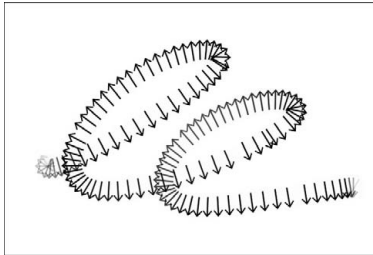

**Direction attribute value at 100%,
Direction mode**

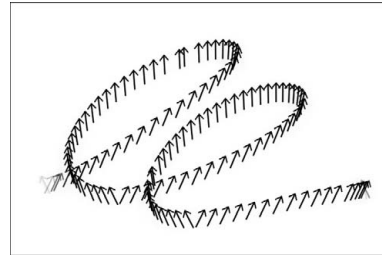

**Direction attribute value at 15%,
Direction mode**

Pressure Exerted on the Pen

The Pressure mode uses the pressure exerted on the pen as the reference value. The harder you press on the pen, the greater the brush attribute value. The softer you press, the lower the brush attribute value.

NOTE The Pressure attribute mode cannot be used in the Graphics menu.

Preferences Affecting Brushes

The Spacing setup preference affects how paint strokes are applied to the canvas.

To enable Brush Spacing:

- 1 Click Setup in the Paint menu.
- 2 Enable Spacing.



This option sets a uniform distance between paint strokes. No matter how fast you move the brush, the brush spreads the paint evenly.

TIP Use a high brush rate when using stamps with the Spacing option enabled. See [Using the Stamp Medium](#) on page 2446.

Using Filters and Special Effects Media

84

Topics in this chapter:

- [Applying Filters](#) on page 2437
- [Using Special Effects Media](#) on page 2439

Applying Filters

When applying filters, it is important to try different brush types and change the brush attributes to create different effects.

Apply filters to the canvas using the brush, Wipe command, or Wash and Shade media. Paint uses the same filter library as the Filter command in the Processing menu.

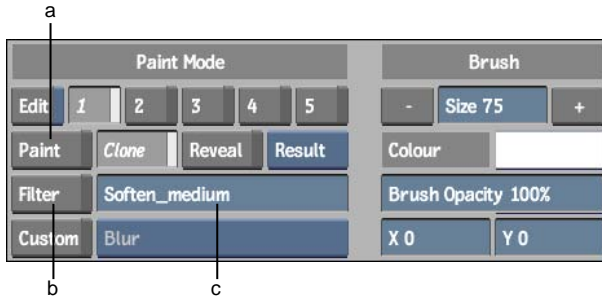

(a) Paint Media button (b) Filter button (c) Filter field

To brush a filter onto the image:

- 1 In the Paint menu, click the Filter field.
The filter library appears.
- 2 Select the filter you want to use.
You are returned to the Paint menu and the filter name appears in the Filter field.
- 3 Click Filter to enable the selected filter.
- 4 Set the brush opacity. The opacity determines the level of filtering. Reduce the opacity value to reduce the level of filtering.
- 5 Paint on the image.

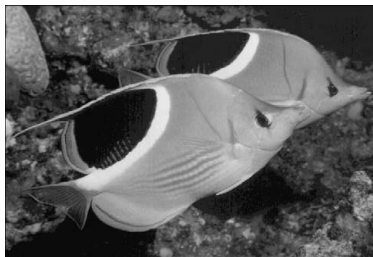

Original image

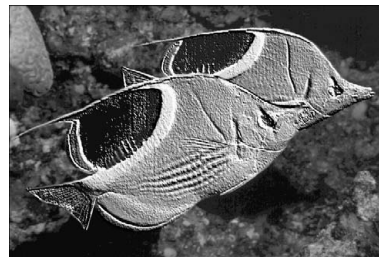

After using the emboss filter

Using Special Effects Media

Special Effects media can be brushed onto the image in Canvas mode. You can also apply the Wash, Shade, and Reveal media to the entire image using the Wipe command. See [Wiping Using Special Effects Media and Filters](#) on page 2452. Only one media type can be used at a time.

Use the media buttons to enable some Special Effects media, for example, the Clone and Reveal media. Other media types, such as Drag and Smear, are enabled using the Custom Media box.

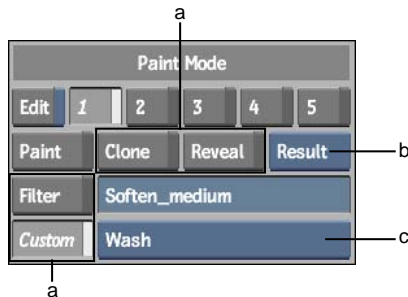

(a) Special Effects Media buttons (b) Reference box (c) Custom Media box

The following Special Effects media are available.

Use:	To:
Blur	Apply a blur filter to portions of the image. See Blurring the Image on page 2440.
Clone	Copy a portion of the image to a new location. See Cloning the Image on page 2441.
Drag	Create an image trail from a selected region of the screen. See Dragging the Image on page 2442.
Impressionist	Paint on colours from a reference clip. See Using the Impressionist Medium on page 2443.
Recursive Clone	Make a number of copies of a selected area of the image. See Using the Recursive Clone Medium on page 2445.
Reveal	Brush a reference image onto the current image. See Revealing a Reference Image on page 2444.

Use:	To:
Shade	Darken or lighten the image depending on the luminance value of the current colour. See Washing and Shading the Image on page 2449.
Smear	Smudge areas of the image. See Smearing the Image on page 2446.
Stamp	Apply a captured image to the image. See Using the Stamp Medium on page 2446.
Warp	Stretch and distort a region of the image. See Warping the Image on page 2448.
Wash	Apply a transparent wash of the current colour to the image. See Washing and Shading the Image on page 2449.

Blurring the Image

Use the Blur medium to blur portions of the image.

To blur the image:

- 1 Click Custom and select Blur from the Custom Media box. The Blur option boxes appear.



(a) Filter Type box (b) Blur Strength box

- 2 Click Canvas.
- 3 Set the brush size according to the size of the area you want to blur.
- 4 Select either a Box or Gaussian filter from the Filter Type box.
- 5 Set the density of the Blur brush from the Blur Strength box. You can choose Light, Medium, or Heavy.

- 6 Drag the brush on the image.



Original image



After using the Blur medium

Cloning the Image

Use the Clone medium to copy a region of the image and paint it on a destination point. The result image is used as the source for the Clone medium. The offset between the origin point and the destination point is set in the Offset fields.

To paint using the Clone medium:

- 1 Click Clone.

The Clone controls appear.



(a) Offset fields

- 2 Click Canvas.
- 3 Set the brush opacity. The brush opacity determines the transparency of the clone. When the opacity value is set to 100%, the clone is completely opaque.

- 4 Set the brush size.
- 5 Set the offset between the origin point and the destination point in the Offset fields.

A tracking circle appears at the offset co-ordinates you specified; this is the destination point for the cloned image.

TIP Press **Ctrl** and drag the cursor to set the destination point.

- 6 Paint on the image.

The image contained within the red circle brush is copied to the region defined by the green circle.



Original image



After using the Clone medium

Dragging the Image

Use the Drag medium to drag a selected area of the image across the canvas. The selected area is painted on the canvas as you drag the brush, creating an image trail.

NOTE The Direction brush attribute cannot be used with the Drag medium.

To use the Drag medium:

- 1 Click Custom and then select Drag from the Custom Media box.
- 2 Click Canvas.
- 3 Set the brush size.
- 4 Position the brush over the region of the image that you want to use. Hold down the cursor to select that region.

5 Drag the brush.

The selected region is painted onto the image as you drag. The pressure of the brush determines the density of the image trail. See [Brush Pressure](#) on page 2430.



Original image



After using the Drag medium

Using the Impressionist Medium

Use the Impressionist medium to brush on colours from a reference clip. The brush opacity determines how much colour is taken from the reference clip. When the opacity value is set to 100%, all the colour is taken from the reference image. At 50%, the colour applied is a 50/50 blend of the reference colour and the result image.

To use the Impressionist medium:

- 1 Click Custom and then select Impressionist from the Custom Media box.
- 2 Click Canvas.
- 3 Set the brush opacity.
- 4 Select a reference image from the Reference box.

- 5 Paint on the image.

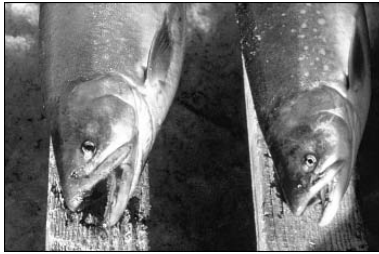

Original image



After using the Impressionist medium

Revealing a Reference Image

Use the Reveal medium to reveal portions of an image or an entire reference image. You can reveal specific areas using the brush or the entire image using the Wipe command. The opacity of the brush determines how much of the reference image is revealed on the image. When the opacity is set to 100%, the reference image applied is completely opaque. At 50%, the reference image applied is a 50/50 blend of the reference image and the result clip.

To reveal a reference image on the canvas:

- 1 Click Reveal.
- 2 Click Canvas.
- 3 Set the brush opacity.
- 4 Select a reference image from the Reference box.
- 5 Paint on the image.



Back image



Result image



The Back image revealed on the Result image

Using the Recursive Clone Medium

Use the Recursive Clone medium to make multiple copies of an area of an image. The result image and the paint applied to it is used as the source. Each copy is a degraded version of its predecessor. The offset between the origin point and the destination point is set in the Offset fields.

To paint using the Recursive Clone medium:

- 1 Click Custom and select Recursive Clone from the Custom Media box. The Recursive Clone options appear.

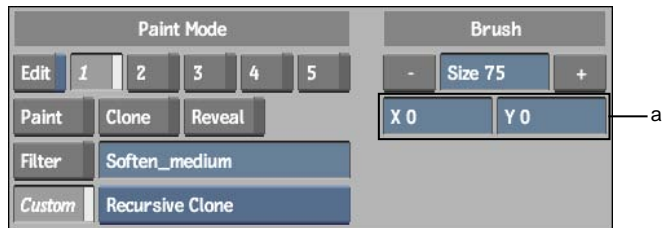

(a) Offset fields

- 2 Click Canvas.
- 3 Set the offset between the origin point and the destination point in the Offset fields. A red tracking circle appears around the destination point.
- 4 Paint on the image. The image contained within the green circle brush is copied to the region defined by the red circle.



Original image

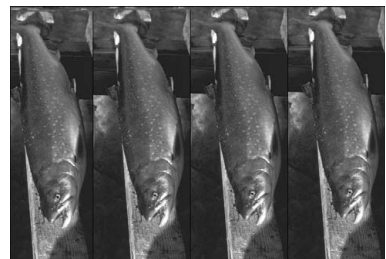

After using the Recursive Clone medium

Smearing the Image

Use the Smear medium to smudge portions of the image.

To smear the image:

- 1 Click Custom and select Smear from the Custom Media box.
- 2 Click Canvas.
- 3 Drag the brush over the area you want to smear.



Original image



After using the Smear medium

Using the Stamp Medium

Use the Stamp medium to capture a portion of the image and apply it to the canvas.

To capture and apply a stamp:

- 1 Click Custom and select Stamp from the Custom Media box.
The Stamp window appears beneath the Brush Size field.

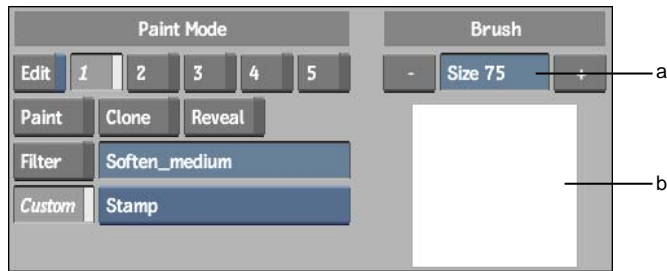

(a) Brush Size field (b) Stamp window

- 2 Click Canvas.
- 3 Set the brush size. Use a small brush to isolate a specific detail of the image. Use a large brush to capture a bigger sample.
- 4 Click and hold the cursor on the Stamp window.
- 5 Without releasing the cursor, move it over the image.
The Stamp window is updated as you move the cursor across the image.
- 6 Release the cursor when the Stamp window contains the part of the image you want to capture.
The brush cursor appears.
- 7 Paint on the image.

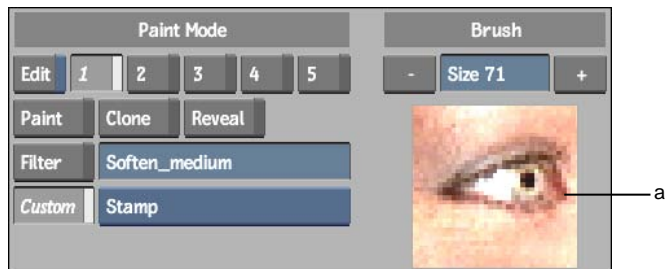

(a) The captured stamp

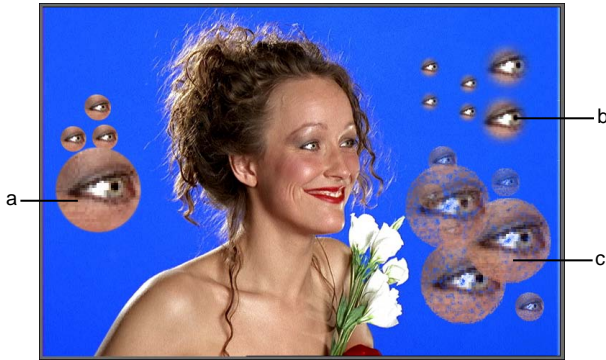

(a) Stamp applied using a circular brush (b) Stamp applied using an air brush (c) Stamp applied using a chalk brush

Saving and Loading Stamps

You can save a stamp and load it in another session to use with a different clip. See [Saving Setups](#) on page 2524.

Warping the Image

Use the Warp medium to stretch and distort regions of the image.

To warp the image:

- 1 Click Custom and select Warp from the Custom Media box.
- 2 Click Canvas.
- 3 Set the brush size.

The area that can be warped is determined by the brush size.

- 4 Select a portion of the image and hold down and drag the cursor to warp the selection.



Original image



After using the Warp medium

Washing and Shading the Image

Use the Wash medium to apply a transparent wash of the current colour to the image. Use the Shade medium to darken or lighten the image. You can wash or shade specific areas using the brush or the entire image using the Wipe command.

With the Shade medium, you darken images using a colour with a low luminance value, and lighten them using a colour with a high luminance value. The opacity of the brush affects the transparency of the paint applied to the image. When the opacity value is set to 100%, the paint applied is completely opaque. As you decrease the opacity, the paint becomes more transparent.

Selecting a Colour Model

You can apply the colour using either the YUV or HLS.

To select a colour model:

- 1 Click Setup.
- 2 Select either YUV Shade/Wash or HLS Shade/Wash.

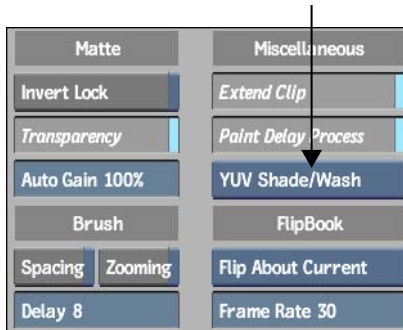

To use Wash or Shade:

- 1 Click Custom, and select Wash or Shade from the Custom Media box.
- 2 Click Canvas.
- 3 Set the current colour.
- 4 Set the brush opacity.
- 5 Paint on the image.

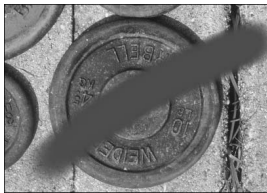

A paint stroke using the Paint medium, current colour red.



A paint stroke using the Wash medium, current colour red.



A paint stroke using the Shade medium, current colour red.

Using Wipe, Fill, and AutoPaint

85

Topics in this chapter:

- [Wiping an Image](#) on page 2451
- [Filling an Image](#) on page 2453
- [Using AutoPaint](#) on page 2457

Wiping an Image

Use the Wipe command to apply colours, filters, and Special Effects media to the entire result image in a single stroke.

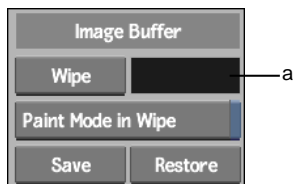

(a) Wipe colour pot

NOTE You can also wipe an image with the AutoPaint Wipe mode. See [Wiping the Canvas in AutoPaint](#) on page 2458.

Wiping Using a Colour

Use the Paint medium to wipe the image with a selected colour. The colour used is set in the Wipe colour pot.

To wipe the image using a colour:

- 1 Set the current colour you want to use for the wipe. See [Selecting Colours](#) on page 2411.
- 2 Click the Wipe colour pot.
The current colour is transferred to the wipe colour.
- 3 Set the brush opacity.
A value of 100% wipes the image with a completely opaque colour.
- 4 Click Wipe.

Wiping Using Special Effects Media and Filters

You can use a filter, or the Reveal, Clone, Wash, and Shade Special Effects media.

To wipe with Special Effects media and filters:

- 1 Set the wipe colour.
- 2 From the Paint Mode controls, select the Special Effects medium to be applied. See [Using Special Effects Media](#) on page 2439.



NOTE If you are using a filter for the wipe, you must enable the Filter button.

- 3 Set the brush opacity.
A value of 100% wipes the image with the full effect of the Special Effects Media or filter.
- 4 Enable the Paint Mode in Wipe button.
- 5 Click Wipe.

Using the Wipe Command in Graphics

You can also use the Wipe command in the Graphics menu. The Wipe command wipes over any objects tacked down on the image. Objects not tacked down are not part of the image and are not wiped over.

Filling an Image

Use the Fill command to fill areas of an image with similar colour values or areas delimited by a colour. These areas can be filled with either a solid colour or a reference image. You can choose how far the filled area extends by specifying how similar the pixels must be in order to be filled. This enables you to fill only the dark areas of an image, or include slightly lighter areas.

Use the Fill controls to set the colour model, range, and softness of the fill.

To display the Fill controls:

- 1 Click Fill in the Paint menu. If the Fill button is hidden by the colour palette, swipe the bottom of the screen.

Defining the Range for the Fill

When you use the Fill command, you specify a range for the colour comparison. The Fill command compares the colour values of adjacent pixels to determine if the values are within the specified colour range. Adjacent pixels within the range are filled.

The range is determined using two values: the colour value of the pixel you select to begin the fill, called the *selection point*, and the value you set in the Range field.

Selecting Colour Channels

You can use either the RGB or YUV model. Within each colour space, you can work with any combination of colour channels. For example, if you select the R, G, and B channels in the RGB colour model, the Fill command considers the red, green, and blue values. Adjacent pixels with red, green, and blue values within the specified range are filled.

Adjusting the Softness

The softness value for the fill determines the amount of colour diffusion applied at the edges of the fill. This value can be adjusted to modify the transition between the filled and unfilled areas. A softness value of 100% produces the greatest amount of diffusion. A softness value of 0% produces a filled area with well-defined edges.

Filling a Region with a Colour

You can choose to fill an image with the current colour.

To fill a region of the image with a colour:

- 1 Click Fill.

The Fill controls appear.

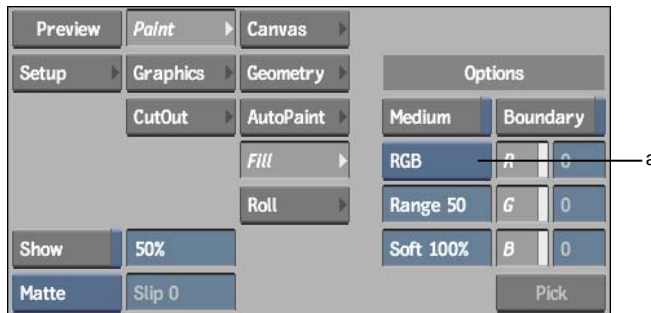

(a) Colour Model box

NOTE To fill a matte, click From Matte. When this button is enabled, the pixels in the matte are used for the colour comparison. If this button does not appear at first, click Matte on the right side of the menu panel.

2 Select a colour model from the Colour Model box.

Select: **To:**

RGB Display the R, G, and B channel buttons. Enable each channel you want to use.

YUV Display the Y, U, and V channel buttons. Enable each channel you want to use.

3 Set the colour range in the Range field.

You can also set a tolerance by enabling the Boundary button and selecting a distinct boundary colour from the image.

4 Set the softness in the Soft field.

5 Set the current colour.

6 Select a point in the area you want to fill. This is the selection point.

The pixels that fall within the specified range are filled with the current colour.



Original image



Fill with range 75 and softness 100



Fill with range 75 and softness 50



Fill with range 50 and softness 100

Filling a Region with an Image

You can fill a region of an image with a reference image instead of a colour. The front, back, or result image can be used as the reference image. The Wash, Shade, Clone, or Reveal media can also be used to perform the fill.

To fill a region with a reference image:

- 1 Click Fill.

The Fill controls appear.

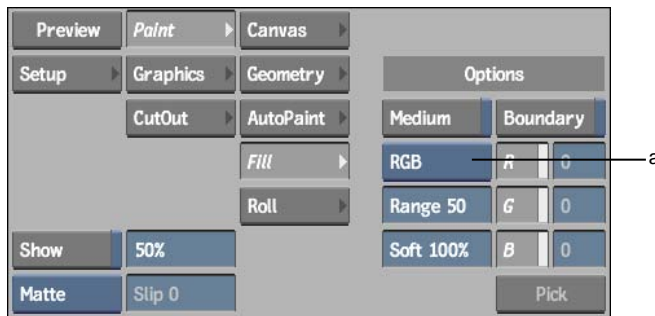

(a) Colour Model box

- 2 Select the colour model and channels you want to work with.
- 3 Set the range and softness in the Range and Softness fields.
- 4 Select the Special Effects medium you want to use (Clone, Reveal, Wash, or Shade). See [Using Special Effects Media](#) on page 2439.
- 5 Set the Reference box to Front, Back, Result, or Saved, and set the brush opacity.
A value of 100% fills the area completely with the reference image.
- 6 Enable Medium.
- 7 Select a point in the area you want to fill.

Filling a Boundary

Use the Boundary option to fill an area of the canvas delimited by another colour.

To use boundary fill:

- 1 Click Fill.

The Fill controls appear.

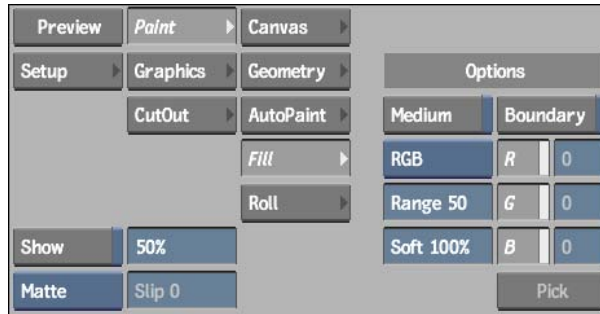

- 2 Select the colour model and channels you want to work with.
- 3 Set the range for the fill in the Range field.
- 4 Enable Boundary.
The Pick button is no longer greyed out.
- 5 Click Pick.
The cursor changes to a colour picker when dragged over the image.
- 6 Drag the colour picker over the canvas without clicking.
The various colour channel values in areas of the image are displayed as you move the colour picker around the canvas.
- 7 Click a point to select the colour for the boundary. You can also select a colour by entering the RGB values directly in the colour channel fields.
The cursor changes to a paint bucket.
- 8 Click the area inside the boundary to fill that region.

NOTE To fill a boundary with a reference image, set the Reference box to Front, Back, or Saved, and enable Medium.

Using AutoPaint

Use the AutoPaint controls to apply paint strokes to each frame in the result clip, a range of frames, or the current frame.

To display the AutoPaint controls:

- 1 Click AutoPaint in the Paint menu. If the controls are hidden by the colour palette, swipe the bottom of the screen.

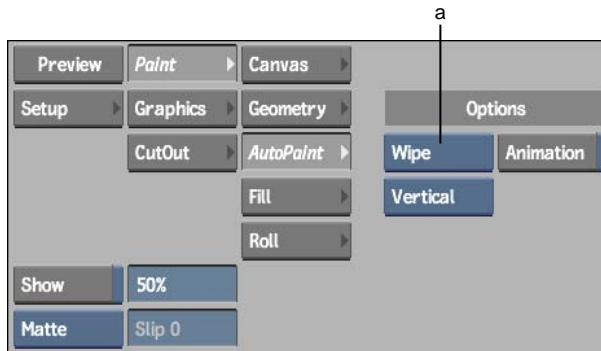

(a) Autopaint Mode box

The AutoPaint Mode options are described as follows.

User Records and plays back a series of manual paint strokes.

Random Applies a number of random strokes to the image.

Wipe Wipes the entire canvas with the current colour or medium.

Wiping the Canvas in AutoPaint

Use Wipe mode to automatically apply paint strokes from left to right, top to bottom, or diagonally across the entire canvas. You can use a filter or any of the Special Effects media except Warp, Drag, and Smear. The size of the brush determines the number of strokes applied. Use a small brush to apply several strokes or a large brush to apply fewer strokes.

To wipe the canvas in AutoPaint:

- 1 Click AutoPaint, and select Wipe from the AutoPaint Mode box. The Wipe menu appears.

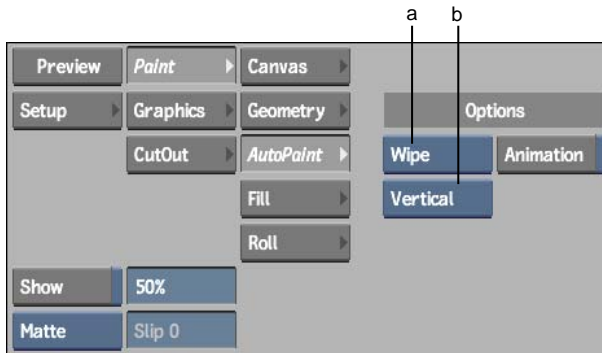

(a) AutoPaint Mode box (b) Wipe Mode box

- 2 Set the current colour.
- 3 Select the Special Effects medium or filter, and set the brush attributes. See [Using Special Effects Media](#) on page 2439, and [Brush Attributes](#) on page 2428.
- 4 Select the Wipe mode in the Wipe Mode box. If this box is not visible, make sure that the attribute mode for the Direction attribute is set to Direction.

Select:	To:
Diagonal	Apply diagonal strokes.
Vertical	Apply strokes from top to bottom.
Horizontal	Apply strokes from left to right.

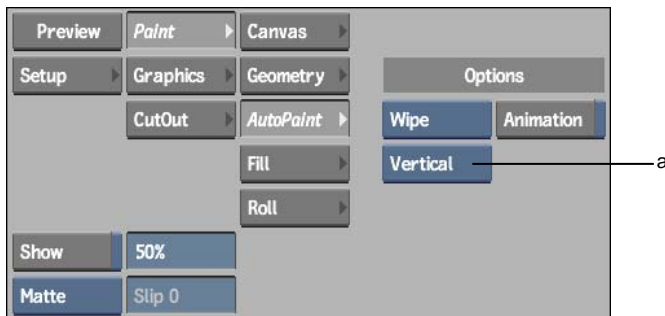

(a) Wipe Mode box

- 5 Enable Animation to display the Channel Editor.
If the Channel Editor is not visible, swipe the bar below the menu.
You can animate all brush attributes as well as the current colour. For information on using the Channel Editor, see [Creating Animations](#) on page 1971.
- 6 Enable Wipe if you are using a filter or colour.
- 7 Click the image to apply the paint strokes only to the current frame. Click Process to apply the paint strokes to each frame in the front clip.

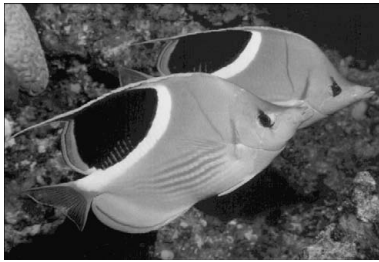

Original image



After using the Wipe command with jitter attribute at 35% and Colour attribute mode set to Front

Applying Random Strokes

Use Random mode to automatically generate a number of paint strokes with random orientation on the image. Use the Samples field to specify the number of random strokes you want to generate. You can use any Special Effects media in Random mode except Warp and Drag.

To apply random paint strokes to the image:

- 1 Click AutoPaint and select Random from the AutoPaint Mode box.
The Samples field appears.

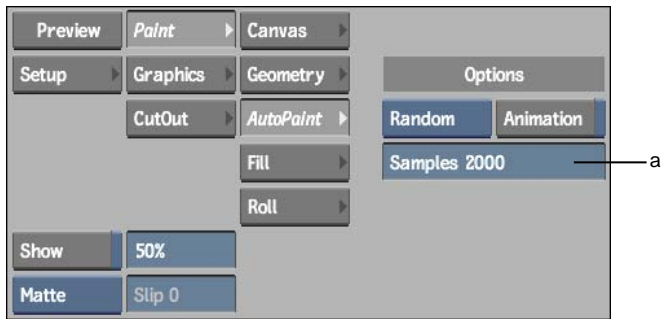

(a) Samples field

- 2 Enter the number of strokes you want to apply in the Samples field.
- 3 Set the current colour.
- 4 Select the Special Effects medium, and set the brush attributes. See [Using Special Effects Media](#) on page 2439, and [Brush Attributes](#) on page 2428.
- 5 Enable Animation to display the Channel Editor. If the Channel Editor is not visible, swipe the bar below the menu.
You can animate the following parameters:
 - Number of strokes
 - All the brush attributes
 - Colour

For information on using the Channel Editor, see [Creating Animations](#) on page 1971.

- 6 Click the image to apply the paint strokes to the current frame only. Click Process to apply the paint strokes to each frame in the front clip.

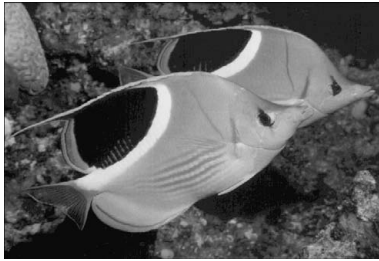

Original image

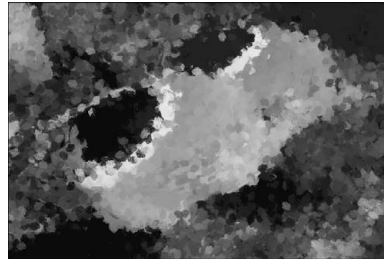

After using the Random command with Jitter attribute at 30% and Colour attribute mode set to Front

Recording Brush Strokes

Use User mode to record and play back a series of paint strokes. Only the positions of the brush strokes are recorded. This means that you cannot change the brush type, current colour, or brush attributes while recording the strokes. You can, however, change or animate these parameters after you finish recording and before you play back the strokes.

TIP You can also play paint strokes created by converting objects (write-ons).

To record a series of brush strokes:

- 1 Click AutoPaint and select User from the AutoPaint Mode box.
- 2 Set the brush characteristics so that you can see the recorded brush strokes on your image.

NOTE The strokes you paint are recorded as a series of points or stamps of the brush. The number of strokes is determined by dividing the number of points by the number of frames. The quality of the rendered strokes depends on the number of recorded points. To record a larger number of points, select a small brush size.

- 3 Enable Record.
- 4 Begin painting on the image.

The position of each brush stroke is recorded, and the stroke count appears in the message bar.

- 5 To stop recording, click below the timebar.

All paint strokes applied to the image while recording are removed from the image and the number of strokes is recorded.

NOTE AutoPaint stores only one set of recorded paint strokes at a time. If you record another set of paint strokes, you lose your previously recorded strokes.

Tracking with AutoPaint

You can apply tracking data to the painted strokes.

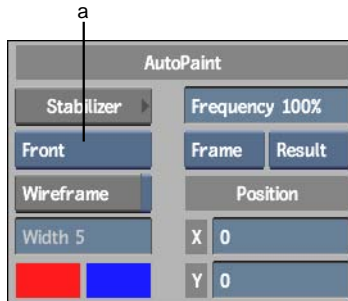

(a) Tracking box

To apply tracking data to recorded strokes:

- 1 Enable Animation.
- 2 Select Front, Back, or Result from the Tracking box and click Stabilizer to track a point and apply the offset information to the recorded strokes.

NOTE You can only track after you record paint strokes.

- 3 Use the X and Y field to offset the painted strokes.
See [Tracking and Stabilizing](#) on page 1781.

Playing Recorded Brush Strokes

After recording brush strokes, you can apply them to the front clip using the Play option, which is activated automatically when you finish recording the paint strokes.

To play recorded strokes:

- 1 Enable Play.

The Play options appear.

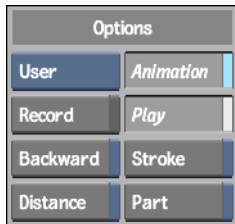

- 2 Define the brush characteristics using the Brush Attribute fields.
- 3 Define the duration of the stroke sequence using the second timebar. Drag the indicator to modify the duration.

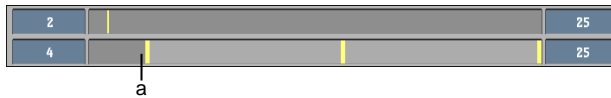

(a) Indicator

The number of strokes is divided by the length of the stroke, defined by the second timebar.

The indicator in the second timebar is identical to a track in the Channel Editor. For more information on using tracks, see [Animation](#) on page 1963.

- 4 Enable the Play options.

Enable:	To:
Part	Play only a part of the recorded strokes. AutoPaint applies the strokes to a frame, erases those strokes, and moves to the next frame. This has the effect of creating streaks on your rendered clip.
Backward	Play the paint strokes backward.

Enable:	To:
Distance	Play paint strokes based on distance. AutoPaint divides the length of paint strokes by the number of frames to determine what to render in each frame.
Stroke	Play the paint strokes simultaneously.

- 5 Enable Animation.
The Animation menu appears.

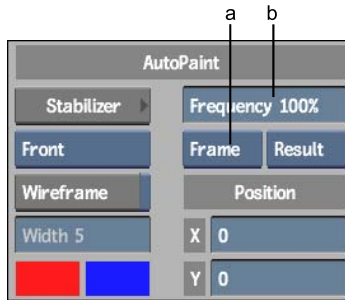

(a) Animation Type box (b) Frequency field

- 6 Enable Wireframe to preview the path(s) of the painted strokes.

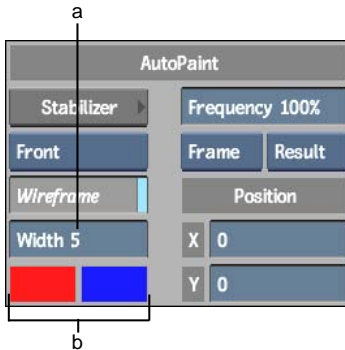

(a) Width field (b) Wireframe colour pots

The wireframe preview shows the complete path(s) of the painted strokes. It also shows what will be painted in each frame as set using the second timebar.

You can set the width of the wireframe using the Width field. You can also change the colour of the path and progression wireframes using the colour pots beneath the Width field.

For Path animation, you define how often AutoPaint reads the Channel Editor values when rendering the points or stamps that make up a given stroke. At a frequency of 100%, AutoPaint reads the Channel Editor values the most frequently.

For example, assume you set your AutoPaint sequence of 100 stamps to run over 10 frames using Path animation. If you set the Frequency field to 100%, AutoPaint reads the Channel Editor values 10 times every frame. If you set the Frequency field to 50%, AutoPaint reads the Channel Editor values 5 times every frame.

TIP Use the Frequency field to lower the processing time for your AutoPaint sequence. Use a low frequency to render a quick preview of the result.

- 7 Swipe the bar at the bottom of the menu to display the Channel Editor. You can animate the following parameters:

- Sampling amount
- X and Y values
- Brush size, rate, pressure, jitter, direction, roll, opacity, and colour
- Tracker translation

NOTE The Channel Editor only appears if Animation is enabled. Also, animation data in the Channel Editor is not erased when you record new strokes.

- 8 To apply the paint strokes, click Process.

NOTE If you are zoomed in on the image and are in the Raster zoom mode, only the visible portion of the image will be processed. This is much faster than using Tiled mode, but will not apply your modifications to the entire frame. For more information on zoom modes, see [Painting on Full-Resolution Film Images](#) on page 2415.

Using Mattes in Paint

86

Topics in this chapter:

- [About Mattes](#) on page 2467
- [Viewing Mattes](#) on page 2468
- [Creating or Modifying Mattes](#) on page 2470
- [Creating High-Contrast Mattes](#) on page 2472

About Mattes

Mattes protect specific areas of the image when you apply paint, filters, or Special Effects media to the canvas. You can also use mattes to limit the area of a cutout.

For instructions on loading mattes into Paint, see [Loading Clips into Paint](#) on page 2406, and [Loading Setups](#) on page 2525.

To use the matte:

- 1 Click Use to enable the matte.

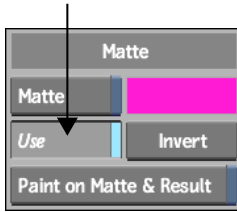

- 2 Paint on the image.
- 3 Click Use again to disable the matte.

Using Mattes with Cutouts

If you enable your matte when creating a cutout, the cutout is limited by the matte. Only objects outside the matte will show up in the cutout. See [Creating a Cutout](#) on page 2512.

Viewing Mattes

You can view the matte as you use it.

To view the matte:

- 1 Load the matte into Paint.
- 2 Enable Show.
- 3 Select Matte in the Reference box.



The matte appears.

Changing the Matte Colour

If the colour used to display the matte blends with the image, you can change its colour.

NOTE The matte is always created using shades of grey.

To change the matte display colour:

- 1 Set the current colour.
- 2 Click the Matte colour pot.

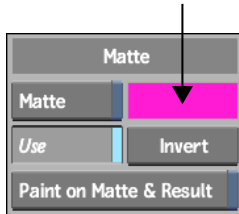

The matte colour display changes to the current colour.

Changing the Matte Display Transparency

When viewing the matte, use the Transparency field to vary the matte display transparency from 0% (completely transparent) to 100% (fully opaque). Press **Alt+T** or click Transparency in the Setup menu to toggle between the last set value and 100%.

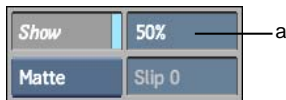

(a) Transparency field

NOTE The transparency value only affects the display of the matte. It does not affect how the matte is used.

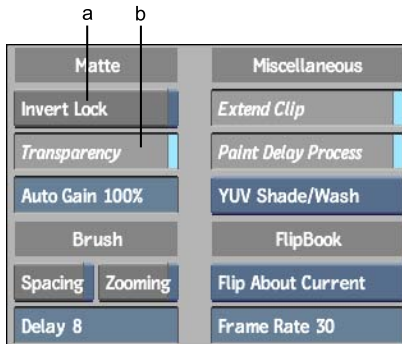

(a) Invert Lock button (b) Transparency button

Inverting the Matte Clip

Click Invert to invert the matte in the current frame. Enable Invert Lock in the Setup menu to invert the matte in every frame of the clip.

Creating or Modifying Mattes

You can create or modify a matte by painting directly on the matte using any brush, Special Effects media, or graphic tool. For information on using graphic and cutout tools to create mattes, see [Using the Cutout Commands](#) on page 2513.

To create or modify a matte:

- 1 Load the matte into Paint.

NOTE You must load a matte clip in order to process a matte in Paint. If you want to create a matte from scratch, load a black source as the matte clip.

- 2 Click Matte.
The Matte menu appears.

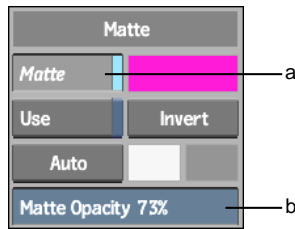

(a) Matte button (b) Matte Opacity field

- 3 Set the paint transparency in the Matte Opacity field.
The value in the Matte Opacity field determines the transparency of the paint applied to the matte. Use a value of 100 to apply fully opaque paint or objects to the matte. Reduce the Matte Opacity value to increase the transparency of the paint.
- 4 Paint or place graphics or cutouts on the matte.
The paint and graphics are applied to the matte. If you use graphic tools, use Tack to tack the graphic to the matte. See [Tacking Down Selected Objects](#) on page 2509.
- 5 You can save the matte in the matte library. See [Saving Setups](#) on page 2524.
- 6 To process the matte clip, click Exit.
The new matte clip is saved to the Desktop with the front clip.

Painting on the Matte and Image

When applying paint strokes or graphics to the image, enable Both to paint the image and the matte simultaneously.

Resetting the Matte

If you do not load a matte, Paint displays the last matte that was loaded.

To erase the matte:

- 1 Click Matte.
- 2 Set the Matte Opacity to 0%.

- 3 Click Wipe.
The matte is erased.

Creating a Gradient Matte

You can use graphics that contain gradients to create a matte that blends from one level of the matte colour to another level. A gradient matte is useful for blending paint strokes or creating soft edges.

To create a gradient matte, draw a graphic with a gradient on the matte, and then use the Channel Editor to change the “a” channel of the start or end colour of the gradient. See [Creating Graphics](#) on page 2476, and [Changing the Object Gradient](#) on page 2494.

Creating High-Contrast Mattes

Use the Auto command to create a high-contrast matte. This command works like the Auto Matte command in the Processing menu. The minimum and maximum luminance values for the matte are set using the two colour pots in the AutoMatte menu. Any pixel with a luminance value below the minimum is set to black, and any pixel with a luminance value above the maximum is set to white.

Unwanted grey areas can be removed from the matte by increasing the percentage in the Auto Gain field in the Setup menu.

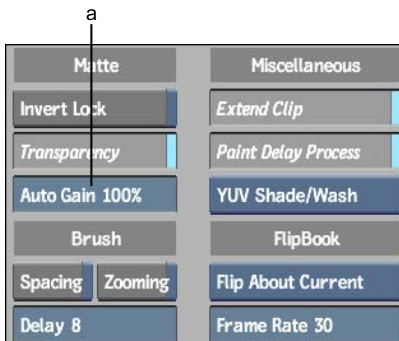

(a) Auto Gain field

Pixel values between the minimum and maximum values are multiplied by the Gain value. The resulting values are clipped at the specified maximum

luminance value. The Gain is expressed as a percentage value. The default value of 100% has no effect on the image since the luminance values are multiplied by 1.

To use the AutoMatte command:

- 1 In the Paint menu, click Matte.
The AutoMatte menu appears.

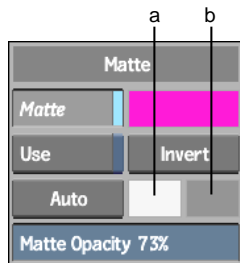

(a) Minimum luminance (b) Maximum luminance

- 2 Set the minimum luminance value for the matte in the colour pot on the left. To set the value, click the field and use the colour picker to select the lightest colour from the image.
- 3 Set the maximum luminance value for the matte in the colour pot on the right.
- 4 Set the Auto Gain for the matte. The Auto Gain field is in the Setup menu.
- 5 Click Auto to generate the matte.
- 6 Click Use to enable the generated matte.

Topics in this chapter:

- [Accessing the Graphics Menu](#) on page 2475
- [Creating Graphics](#) on page 2476
- [Using the Object Tools](#) on page 2477
- [Selecting Objects](#) on page 2486
- [Editing Objects](#) on page 2488
- [Setting the Object Resolution and Display](#) on page 2490
- [Setting the Object Attribute](#) on page 2492
- [Changing the Object's Appearance](#) on page 2493
- [Changing the Size or Position of an Object](#) on page 2497
- [Changing the Shape of an Object](#) on page 2498
- [Converting Graphics to AutoPaint Strokes](#) on page 2501
- [Animating Graphics](#) on page 2502
- [Saving and Restoring Objects](#) on page 2507
- [Tacking Down Objects](#) on page 2508

Accessing the Graphics Menu

To access the Graphics menu, click the Graphics button in the Paint menu. Some options may be hidden if the colour palette is open. Swipe the cursor across the bars at the bottom of the screen to hide the colour palette.



Creating Graphics

Graphics can be used to create cutouts or mattes, or to apply geometrical shapes, text, and fills to the result clip.

To create a graphics object:

- 1 In the Paint menu, click Graphics.
- 2 Click Add.
- 3 Select the type of object to add by selecting an icon in the Object Tools window.



- 4 Draw the object on the image. See [Using the Object Tools](#) on page 2477.
- 5 Set the resolution to be used when adding or editing objects. See [Setting the Object Resolution and Display](#) on page 2490. Objects appear at full resolution when they are drawn.
- 6 Set the object's attributes and gradient. See [Setting the Object Attribute](#) on page 2492, and [Changing the Object Gradient](#) on page 2494.
- 7 Set the object's colour in the Current Colour pot. See [Selecting Colours](#) on page 2411.
- 8 Resize and move the object. See [Changing the Size or Position of an Object](#) on page 2497.
- 9 Use the Transformation box or controls to move, rotate, or scale the object. See [Changing the Shape of an Object](#) on page 2498.
- 10 Use the Animation controls to animate the object. See [Animating Graphics](#) on page 2502.
- 11 Click the Tack button to permanently place the object on the result clip.

Once the object has been tacked down, it cannot be moved, rotated, deleted, resized, or copied. See [Tacking Down Objects](#) on page 2508.

Auto Edit After Add

After you add an object to the image, Paint automatically switches from Add mode to Edit mode. You can turn off this default setting by disabling the Auto Edit After Add button in the Setup menu. You can then add objects one after another without interruption.

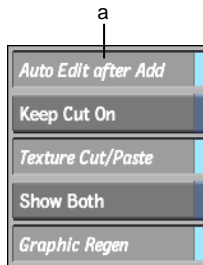

(a) Auto Edit After Add button

Using the Object Tools

A number of predefined graphic tools are available in Paint. The cursor looks the same for all graphic types. When you move the cursor onto an image, it appears as a small green cross with crosshairs that extend the width and height of the canvas. The crosshairs help align objects on the image.

Each tool has its own icon in the Object Tools window.

To select an object tool:

- 1 Scroll through the Object Tools window.



Click the Object Tools window and drag left or right. Use the left mouse button to scroll slowly, the middle button to scroll faster, and the right button to scroll the fastest.

- 2 Click the object tool icon you want to use.
The selected object tool is highlighted by a blue outline.

NOTE Only one object tool can be active at a time.

Drawing a Line

Use the Line object tool to draw a single straight line or a multi-line object (a series of lines joined end-to-end).

To draw a line or a series of lines:

- 1 In the Graphics menu, click Add.
- 2 Select the Line tool in the Object Tools window.
The Create Multiple Lines button appears.
- 3 Click Create Multiple Lines.
- 4 To draw multiple lines, move to the canvas and click to place the start point of the first line. Click again to draw the end point. Continue clicking to draw more lines.
- 5 To end a multiple line object, click Create Multiple Lines.
- 6 To draw single lines, move to the canvas and click, drag, and release.
Paint draws the line as you drag.

Drawing a Rectangle

Use the Rectangle object tool to draw a rectangle or square in one of two ways:

- Corner-to-corner, with the two vertices located at diagonally opposite corners of the rectangle
- Centre-to-corner, with the first vertex at the centre of the rectangle and the second at one corner

To draw a rectangle from corner-to-corner:

- 1 In the Graphics menu, click Add.

- 2 Select the Rectangle tool in the Object Tools window.
- 3 Press the cursor to anchor one corner of the rectangle. Do not release the cursor.
- 4 Drag the cursor diagonally. You can adjust the width and height of the rectangle as long as you hold down the cursor.
- 5 Release the cursor to anchor the second vertex.
The rectangle is drawn on the image.

To draw a rectangle from centre-to-corner:

- 1 In the Graphics menu, click Add.
- 2 Select the Rectangle tool in the Object Tools window.
- 3 Press **Alt**.
- 4 Position the cursor where you want to place the centre of the rectangle and press down.
- 5 Drag diagonally, and release the cursor when the rectangle is the correct size.

Drawing a Square

Press **P** while you draw and repeat the procedure for drawing a rectangle from corner-to-corner.

Drawing a Triangle

Use the Triangle object tool to draw a triangle or equilateral triangle. The vertices are located at the three corners of the triangle.

To draw a triangle:

- 1 In the Graphics menu, click Add.
- 2 Select the Triangle tool in the Object Tools window.
- 3 Position the cursor and press to anchor the first vertex on the image. Do not release the cursor.

- 4 Drag the cursor horizontally to draw the base of the triangle. You can continue to adjust the length of the base as long as you press down on the cursor.
 - 5 Release the cursor to anchor the second vertex.
 - 6 Move the cursor to where you want to place the third vertex. You can continue to adjust the position of the third vertex until you press down on the cursor. Press to anchor the third vertex.
- The triangle is drawn on the image.

Drawing an Equilateral Triangle

An equilateral triangle has three sides of equal length. To draw an equilateral triangle, repeat the procedure for drawing a triangle and press **P** while drawing the base of the triangle. This also establishes the height of the triangle. Release the cursor to anchor the second and third vertices on the image.

Drawing an Ellipse

Use the Ellipse object tool to draw an ellipse defined by three vertices. The first vertex determines the centre of the ellipse. The second vertex determines the horizontal radius of the ellipse. The third vertex determines the vertical radius.

To draw an ellipse:

- 1 In the Graphics menu, click Add.
 - 2 Select the Ellipse tool in the Object Tools window.
 - 3 Position the cursor at the centre of the ellipse and press to anchor the point on the image. Do not release the cursor.
 - 4 Drag the cursor horizontally to establish the width of the ellipse. You can continue to adjust the width as long as you press down on the cursor.
 - 5 Release the cursor to anchor the second vertex.
 - 6 Move the cursor along the vertical axis to position the third vertex. You can continue to adjust the height of the ellipse until you press down on the cursor. Press to anchor the third vertex.
- The ellipse is drawn on the image.

To draw a circle with the Ellipse tool:

- 1 In the Graphics menu, click Add and select the Ellipse tool.
- 2 Press **P**.
- 3 Position the cursor at the centre of the circle and press to anchor the point on the image. Do not release the cursor.
- 4 Drag the cursor horizontally to establish the radius of the circle. Notice that there are two vertices at the edge of the circle, as there are for an ellipse.
- 5 Release the cursor and the **P** key to anchor the second and third vertices. The circle is drawn on the image.

Drawing a Circle

Use the Circle object tool to draw a circle in one of two ways:

- Centre-to-edge, with one vertex at the centre of the circle and a second on the circumference
- Edge-to-edge, with two vertices at opposite points on the circumference

To draw a circle from edge-to-edge:

- 1 In the Graphics menu, click Add.
- 2 Select the Circle tool in the Object Tools window.
- 3 Position the cursor at the centre of the circle and press to anchor that point on the image. Do not release the cursor.
- 4 Drag the cursor to establish the radius of the circle. You can continue to adjust the size of the circle as long as you press down on the cursor.
- 5 Release the cursor to anchor the second vertex. The circle is drawn on the image.

To draw a circle from centre-to-edge:

- 1 In the Graphics menu, click Add and then select the Circle tool.
- 2 Press and hold **Alt**.

- 3 Drag the cursor to establish the radius of the circle.
When the circle is the required size, release the cursor.

Drawing a Polygon

Use the Polygon object tool to create a series of connected lines that form a closed or open object. You can specify how the vertices of the polygon should be connected by selecting one of the options from the Polygon Mode box.

To draw a polygon:

- 1 In the Graphics menu, click Add.
- 2 Select the Polygon tool in the Object Tools window.
The Polygon menu appears.



(a) Polygon Mode box (b) Sides field

- 3 Select an option from the Polygon Mode box to set the type of curve used to join the vertices of the polygon.

Select:

To:

Linear

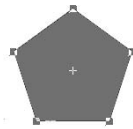

Use straight lines to join the vertices of the polygon.

Cardinal

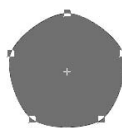

Use a smooth curve that passes through the vertices of the polygon.

Select:**To:**

Bspline

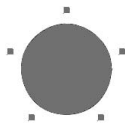

Use a very smooth curve that passes on the inner side of the vertices of the polygon.

Bezier

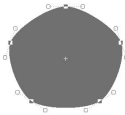

Use Bezier curves. Each vertex of the polygon has a tangent with two tangent handles. In Edit mode, you can move the tangent handles to adjust the slope of the polygon. See [Editing a Bezier Curve](#) on page 2500.

The minimum number of vertices for a polygon depends on the type of interpolation used. A polygon should have at least three vertices when using Linear interpolation, or four when using Cardinal or Bspline interpolation. The maximum number of vertices is 255. A polygon can be concave.

- 4 To create an open-ended polygon, click Opened Shape.
- 5 Position the cursor at one vertex of the polygon, and click to anchor that point on the image.
- 6 Release the cursor and move it to where you want the next vertex of the polygon. You can continue to adjust the positioning of the next vertex until you press down on the cursor. Press to anchor the point on the image.
- 7 Repeat steps 4 and 5 for each vertex.
- 8 To close the polygon, press anywhere outside the canvas.
The polygon is drawn on the image.

Rubber Banding

Rubber banding is the default setting for drawing polygons and lines. This means that a vertex is added to the polygon only when you press and release the cursor.

To draw a polygon with multiple vertices, disable the Rubber Banding button in the Setup menu. When you drag the cursor while drawing a polygon or line, vertices are drawn on the image.

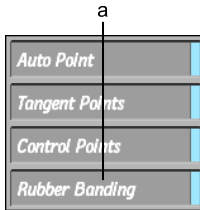

(a) Rubber Banding button

Drawing Regular Polygons

Draw regular polygons using the Sides field and the **P** key. A polygon can have three or more sides. This enables you to draw a triangle or a square based on the centre point of the object.

To draw a regular polygon:

- 1 In the Graphics menu, click Add.
- 2 Select the Polygon tool in the Object Tools window.
- 3 Enter the number of sides for the polygon in the Sides field.
- 4 Press **P**.
- 5 Position the cursor over the image and press down.
This is the centre of the polygon.
- 6 Drag the cursor away from the centre point. The polygon is drawn on the image. You can continue to adjust the size of the polygon as long as you press down on the cursor.
- 7 When the polygon is the correct size, release the cursor.
The polygon is drawn on the image.

Drawing a Fill Object

Use the Fill object tool to fill areas of an image with colour. While this is similar to using the Fill command in the Paint menu, you can only use this tool with colour, Shade, and Wash, and not to fill areas with a reference image. However, you can edit fill objects after you draw them.

NOTE A fill object cannot have a gradient.

To draw a fill object:

- 1 In the Graphics menu, click Add.
- 2 Select the Fill object in the Object Tools window.
The Fill object controls appear.

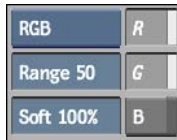

- 3 Select a colour model from the Colour Model box (RGB or YUV).
- 4 Select the colour channels you want to use (R, G, and B, or Y, U, and V).
The choice of colour channels determines how Paint evaluates the area you want to fill. For example, if you select R, G, and B, Paint fills areas whose adjacent pixels have red, green, and blue values in the specified range. If you select only R, Paint fills only areas whose adjacent pixels have red values in the specified range.
- 5 Enter the Range and Softness values for the fill.
The range determines how far the fill spreads from the point you click on the image; if you increase the range, you increase the fill area. The softness determines how much diffusion occurs at the edges of the fill; if you increase the softness, you increase the diffusion at the edges of the fill.
- 6 Move the cursor to the canvas and click inside the area to fill.
Paint fills the area with the current colour starting at the point you click.

NOTE The colour of the image and the channel, range, and softness settings determine the extent of the fill. As you move the fill object, it changes size and shape in response to the different colours in the image.

Drawing a Text Object

Use the Text object tool to add text to the image. You can change the size, kerning, and inclination of the text string.

To add a text object:

- 1 In the Graphics menu, click Add.
- 2 Select the Text tool in the Object Tools window.
The Text object controls appear.



(a) Text field (b) Font field

- 3 Click the Font field and select a new font from the font library.

NOTE By default, Paint uses the font declared on the `TextDefaultFont` line in the configuration file. Refer to the *Autodesk Visual Effects and Finishing Configuration File Reference Guide*. See also [About Fonts in Flame](#) on page 873.

- 4 Click the Text field, type the text string, and click Enter.
- 5 Click the image to place the text object.
You can adjust the size, kerning, and italics of the text in Edit mode.

Use:	To:
Size	Adjust the size (in pixels) of the text.
Italic	Incline the text. Enter a positive value to slant the text to the right, and a negative value to slant it to the left.
Kern	Adjust the space (in pixels) between all letters in the text.

Selecting Objects

You must select an object before you can edit it. In Edit mode, you can select objects in three ways:

- Click an object to select it.

- Use the Selected field to select individual objects.
- Use the All command to select all objects at once.

Using the Selected Field

As you add objects to the image, they are numbered sequentially, starting at 1. You can select an object by specifying the number of the object in the Selected field.

As you change the number in the Selected field, the corresponding object is highlighted by a selection box.

To select a single object using the Selected field:

- 1 Set the number in the Selected field to the number of the object you want to edit.

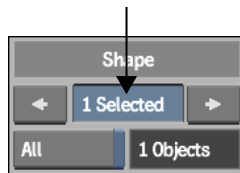

You can also click the < and > buttons beside the Selected field to move through the sequence.

- 2 When the selection box outlines the object, release the cursor. You can now edit it.

Selecting More than One Object

To select an additional object, hold down **Shift** and click another object. Repeat this step for each object you want to select.

Deselecting Objects

To deselect an object or objects, select a different object or click the Add button.

Selecting All Objects

To select all the objects, click the All button. All is shown in the Selected field. Click it again to deselect them.

Editing Objects

Use the object controls to copy, delete, hide, or layer objects.



Copying Objects

Use the Copy command to create multiple copies of an object. Once a copy is created, it can be selected and edited like any other object.

To copy an object:

- 1 In the Graphics menu, click Copy.
- 2 Click the object you want to copy. Do not release the cursor.
A copy of the object is superimposed on the original image. You cannot see the copy until you drag it to a new location.
- 3 Drag the copy to a new location.
- 4 When the copy is positioned correctly on the image, release the cursor.

Deleting Objects

Use the Delete command to remove one or more objects from the image.

To delete one or more objects:

- 1 Select the objects you want to delete. Click an individual object or use the Selected box to select an object. To select multiple objects, click an object, press **Shift**, and click any other objects you want to delete.
- 2 Click Delete.
All selected objects are removed from the image.

To delete all objects from the image:

- 1 Enable All.
- 2 Click Delete.
All objects are deleted from the image.

Hiding Objects

Use the Hide/Unhide commands to hide or unhide objects before they are tacked onto the image.

To hide or unhide one or more objects:

- 1 Select the objects you want to hide. Click an individual object or use the Selected box to select an object. To select multiple objects, click an object, press **Shift**, and click any other objects you want to hide.
- 2 In the Graphics menu, click Edit and then click Hiding.
The Hide options appear.

Select:	To:
Hide Selected	Hide all selected objects.
Hide Unselected	Hide all objects that are not selected.
Unhide All	Show all hidden objects.

Changing the Order of Overlapping Objects

Objects can be drawn so they overlap other objects to produce a stack of objects.

To send an object to the bottom of the stack:

- 1 Select the object.
- 2 In the Graphics menu, click Push and then click the object until it is at the bottom of the stack.

NOTE To bring the object back to the front, click the object until it moves to the front.

Setting the Object Resolution and Display

Use the Object Resolution box to set the resolution while drawing or editing objects. The objects are regenerated at high resolution once you release the cursor at the end of each editing operation. Use the options in the Setup menu to affect the display of the graphics before they are tacked down onto the image.

To set the object resolution:

- 1 Select an option from the Object Resolution box.

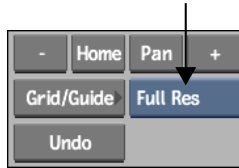

Select:	To:
Full Res	Display the object at full resolution when updating. This is helpful for displaying gradients, but slows down the rate at which image display is refreshed.
Low Res	Display the object at low resolution when updating.
Wireframe	Display the object as a wireframe when updating.

Wireframe Display Options

The Thick Line and Solid Line buttons in the Setup menu determine the thickness and continuity of the wireframe.

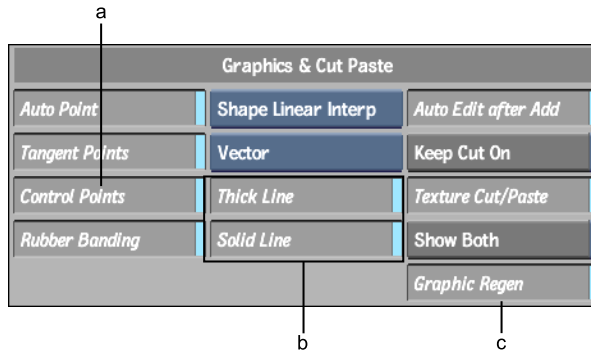

(a) Control Points button (b) Thick Line and Solid Line buttons (c) Graphic Regen button

Enabling and disabling the Thick Line and Solid Line buttons affects the wireframe as follows:

- When Thick Line is enabled, the wireframe has a thickness of 2 pixels.
- When Thick Line is disabled, the wireframe has a thickness of 1 pixel.
- When Solid Line is enabled, the wireframe is unbroken.
- When Solid Line is disabled, the wireframe is dashed.

Increasing Editing Speed

To speed up editing, disable the Graphic Regen button in the Setup menu. Instead of waiting for the graphics objects to be regenerated at the end of an editing operation, the objects appear at the display resolution. This can be a useful time-saving feature.

Hiding the Object Vertices

Each object is defined by two or more vertices. These vertices, or tangent handles, appear while you are drawing or editing the object.

Disable the Control Points button in the Setup menu to turn off the display of the vertices while you are drawing or editing the object. This feature is useful if you want to trace the outline of a figure.

Displaying Anamorphic Geometry

Select Use Aspect Ratio in the Rendering area of the Setup menu to draw and display anamorphic geometry. For normal display, click Use Aspect Ratio and switch to Use Square Pixels.

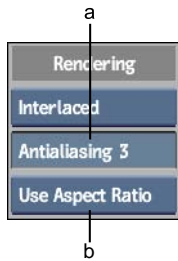

(a) Anti-alias field (b) Use Aspect Ratio option

Anti-Aliasing for Objects

The jagged edges that can occur along diagonal and curved lines in geometry are caused by aliasing, or insufficient spatial sampling of the image. The process of minimizing jagged edges by increasing the sampling rate is called *anti-aliasing*.

Use the Anti-alias field in the Rendering Setup menu to specify an anti-aliasing factor for geometry. When the value is set to 1, no anti-aliasing occurs. Best results are obtained with a value of 4.

Setting the Object Attribute

Use the Object Attribute box to set the display mode for the object you add to the image.

To change the object attribute:

- 1 In the Graphics menu, click Edit.
- 2 Select the object you want to edit.
- 3 Click Attributes.
- 4 Select an option from the Object Attribute box.

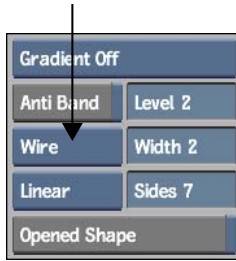

Select:	To:
Solid	Draw a filled object with a well-defined edge. Use the Brush Opacity field to set the object's transparency. No other brush attributes or types are available. Line objects cannot be set to Solid.
Outline	Draw an outline of the object. Use the Brush Attribute buttons to set the appearance of the outline. See Changing the Object's Appearance on page 2493.
Fuzzy	Draw a solid object with a soft edge. Use the Brush Attribute fields to set the appearance of the outline.
Wire	Draw a wireframe object. Use the Brush Opacity field to set the object's transparency. No other brush attributes or types are available.

Changing the Object's Appearance

You can change the appearance of an object by changing any of the following display attributes:

- Current colour
- Brush attribute values or modes
- Special Effects media or filters
- Colour gradient

Changing display attributes affects all currently selected objects. See [Selecting Objects](#) on page 2486.

Setting Brush Attributes and Modes

In the Graphics menu, you can only change brush attributes and modes when using the Outline or Fuzzy attribute. See [Brush Attributes](#) on page 2428.

If the Brush Attribute controls are not visible, swipe the bar at the bottom of the menu. Use the Current Colour pot to set the graphic's colour, and the Opacity field to set the opacity of the object, or the effect a graphic has on the image.

Using Filters and Special Effects Media with Graphics

Any filter can be used with objects. Only the Paint, Clone, Reveal, Wash, and Shade Special Effects media can be used. See [Using Special Effects Media](#) on page 2439.

Changing the Object Gradient

All objects, except the fill object, can have a gradient. You can edit a gradient or apply a gradient to an object that does not have one. A selected object with a gradient displays a gradient control bar that you can use to edit the orientation of the gradient.

To edit a colour gradient:

- 1 In the Graphics menu, click Edit.
- 2 Select the object you want to edit.
- 3 Click Attributes.
- 4 Select an option from the Gradient box.

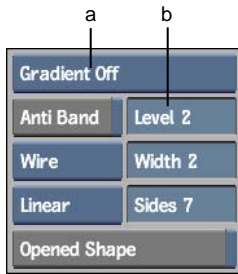

(a) Gradient box (b) Noise Level field

Select:	To:
Rectangular Gradient	Use a rectangular gradient in which colour changes from top to bottom.
Circular Gradient	Use a circular gradient in which colour changes from centre to edge.
Gradient Off	Turn off the gradient and use a solid colour.

5 Set the colours for the gradient. See [Using the Colour Gradient Bar](#) on page 2414.

6 To eliminate banding, enable Anti Band.

Banding normally appears only if you are working at 8-bit colour depth and if the gradient that you apply is stretched.

TIP You can also set a noise level to the anti-band function. Noise may help when colour bands are very large. Set the value in the Noise Level field to 7 to apply the maximum noise, or lower it to apply less dither/noise. If you set the value to 0, no noise is applied.

7 Use the gradient control bar to change the object's gradient.

Using the Gradient Control Bar

When you select an object with a gradient, Paint displays a gradient control bar in addition to the object transformation box. The gradient control bar has two handles at each end that show the colours of the gradient. In a rectangular gradient, the bar also indicates the direction of the gradient.

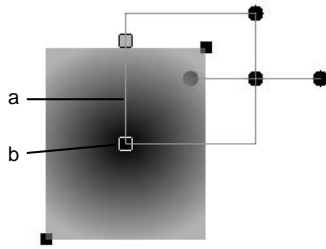

(a) Gradient control bar (b) Centre point of gradient

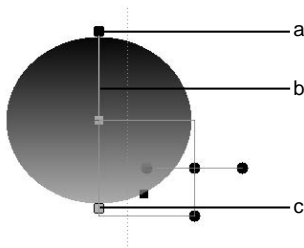

(a) Start point of the gradient (b) Gradient control bar (c) End point of the gradient

NOTE If you want to move the transformation box, press **M** and click the location where you want to move the box.

To use the gradient control bar:

- 1 Select an object with a gradient, or add a gradient to an object.
Paint displays the transformation box and the gradient bar.
- 2 Move the handles of the gradient control bar to change the orientation and location of the gradient.
In a rectangular gradient, this affects the gradient orientation. For example, the default orientation for a rectangular gradient is top to bottom. If you drag one of the handles left or right, you change the orientation to diagonal. If you drag the handles so the gradient bar is horizontal, you get a rectangular gradient with the colours blended from side to side.
If you select the centre colour handle in a circular gradient, you can move the gradient's centre inside the object or even outside it.
- 3 To decrease the amount of one colour visible in an object, move the handle to the edge or outside the object.

Changing the Size or Position of an Object

Use the transformation box, or the transformation controls in the Axis Transformation menu, to change the size or position of an object. You can use the transformation box and controls to modify the object in the following ways:

- Move the object in any direction on the image.
- Rotate the object about its centre point.
- Change the size of the object.

You can translate, resize, or rotate more than one object at the same time by selecting all the objects you want to edit.

Using the Transformation Box

To display the transformation box, click the Edit button in the Graphics menu and click the object you want to edit.

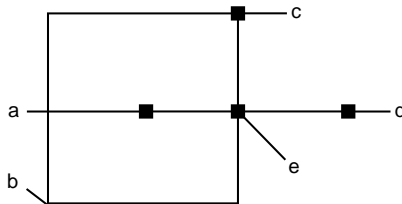

(a) Reset handle (b) Centre point (c) Resize handle (d) Rotation handle (e) Translation handle

The position of the transformation box is saved for each object. To move the transformation box, press **M** and click the destination.

Resize handle To change the size of an object, drag the resize handle in any direction. To maintain an object's proportions, press **P** as you drag the resize handle.

Centre point To change the point around which the object rotates, move the centre point.

Rotation handle To rotate the object about its centre point, drag the rotation handle.

Translation handle To move the object in any direction on the image, drag the translation handle. The transformation box moves with the object.

Reset handle To restore the object to its initial size and position on the image, click the reset handle.

Using the Transformation Controls

Use the transformation controls to translate, rotate, and resize a selected object. To display the transformation controls, select an object and click the Transform button.

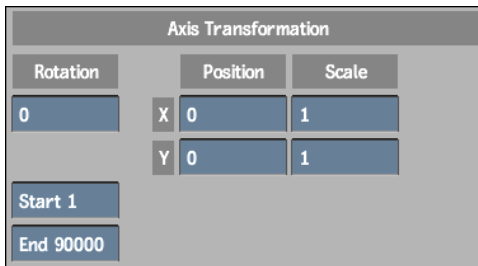

X (Position) Move the object along the horizontal axis (X-axis).

Y (Position) Move the object along the vertical axis (Y-axis).

X (Scale) Change the size of the object along the horizontal axis.

Y (Scale) Change the size of the object along the vertical axis.

Rotation Set the object's angle of rotation along the Z-axis. The object is always rotated around its centre point.

Reset Use the Reset button to reset the object to its initial size and position.

Start and End Numeric Fields Use these fields to set when the object appears in the clip.

Changing the Shape of an Object

To change the shape of an object, such as a polygon or a line, you must add, delete, or move a vertex on the object.

To change the shape of an object:

- 1 In the Graphics menu, click Edit.

- 2 Select the object you want to edit.
The object vertices and the transformation box appear on the selected object.
- 3 Press the vertex you want to edit and drag it to a new location. When you are satisfied with the new position, release the cursor.

Adding and Deleting Vertices on a Polygon or Line

Change the shape of a polygon or line by changing its number of vertices.

To add a vertex to a polygon or line:

- 1 In the Graphics menu, click Edit.
- 2 Select the polygon or line you want to edit.
The vertices for that object are selected.
- 3 Press **A**.
- 4 Press on one of the existing vertices and drag outward. A vertex is added counterclockwise to the selected point.
To add a point clockwise to the selected point, press **Ctrl+A**.
- 5 Repeat steps 3 and 4 for each vertex you want to add to the object.

To delete a vertex from a polygon or line:

- 1 In the Graphics menu, click Edit.
- 2 Select the polygon or line you want to edit.
The vertices for that object are selected.
- 3 Press **D**.
- 4 Click the vertex you want to delete.
The selected vertex is deleted from the object.
- 5 Repeat steps 3 and 4 for each vertex you want to delete on the object.

The Auto Point Command

When you add or delete a vertex on a polygon or line, the same point is added or deleted on all shapes for that object. You can disable this option in the

Setup menu. When the Auto Point button is disabled, any point you add or delete on a shape is added/deleted in the current shape key only.

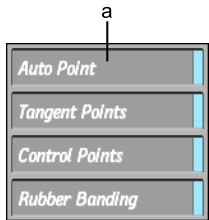

(a) Auto Point button

Editing a Bezier Curve

When you use the Bezier option to draw a polygon, each vertex of the polygon has two tangents. Each tangent ends with a handle.

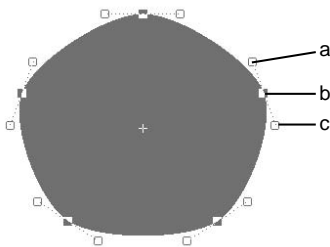

(a) Tangent (b) Vertex (c) Handle

Use Edit mode to move a tangent handle and adjust the slope of the adjacent side of the polygon. When you move one tangent handle, the tangent's reciprocal handle moves in the opposite direction because handles A and B are joined to keep the joint at the intersection of the two edges smooth.

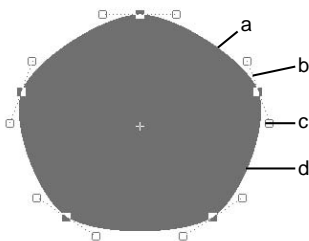

(a) Edge A (b) Tangent A (c) Handle B (d) Edge B

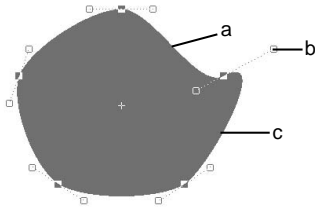

(a) Edge A (b) Handle B (c) Edge B

To adjust the slope on one side of the vertex only, press **B** and click the vertex. This breaks the tangent so that you can move its handles independently. To reset the tangent, press **B** and click the vertex again.

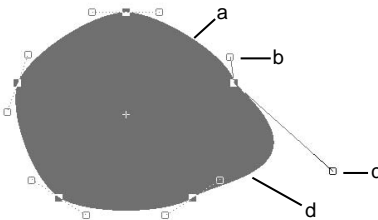

(a) Edge A (b) Handle A (c) Handle B (d) Edge B

Converting Graphics to AutoPaint Strokes

Use the Convert command to convert objects to AutoPaint strokes.

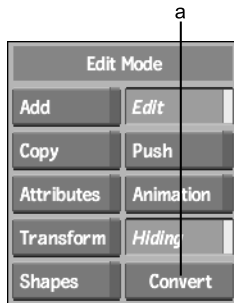

(a) Convert button

You can play the paint strokes using the AutoPaint controls in the Paint menu. See [Using AutoPaint](#) on page 2457.

The following shows how a hexagon is drawn over six frames. One edge is drawn in each frame. After the object is converted to AutoPaint strokes, it is always drawn as an outline regardless of its attributes in the Graphics menu.

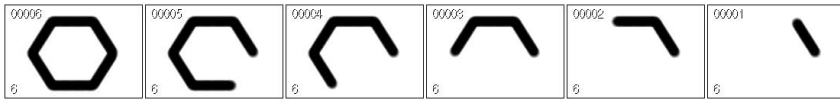

To determine how much of an object to draw in each frame, the number of edges in the object is divided by the number of frames in the clip. The polygons are drawn one after the other in the order in which they were drawn in the Graphics menu.

To convert an object to AutoPaint strokes:

- 1 Select the object.
- 2 Click Convert and Confirm.

Animating Graphics

Use the Channel Editor and Shape Animation controls to animate Paint graphics. You can animate the position, display, and shape of a graphic. To display the Channel Editor, click the Animation button and swipe the cursor across the bottom of the screen.

For information on using the Channel Editor, see [Animation](#) on page 1963.

Animation Parameters

The following parameters can be animated for every object:

- Position, rotation, and size
- Brush attributes
- Gradient orientation, transparency, and colour
- Colour (red, green, and blue channels)
- Wireframe width
- Range and Softness of a fill object
- Transparency

■ Size, Kerning and Italics for a text object

NOTE In Paint, the commands in the Edit Mode box can be performed on animation curves only. To modify a keyframe by editing the object in the image window, you must use the editing commands in the Graphics menu.

Shape Animation

To animate the shape of an object, you must create keyframes with the Shape Animation controls. Each shape you define becomes a keyframe in the Shape channel of the Channel Editor. The difference between the keyframes is interpolated and the shape animation is created.

The Shape channel is used to identify the number and location of shape keyframes in a clip. Use the shape curve to control the rate at which an object changes to a new shape. The following figure shows the Shape channel for an object that changes from shape 1 in frame 1, to shape 2 in frame 8, and shape 1 in frame 15.

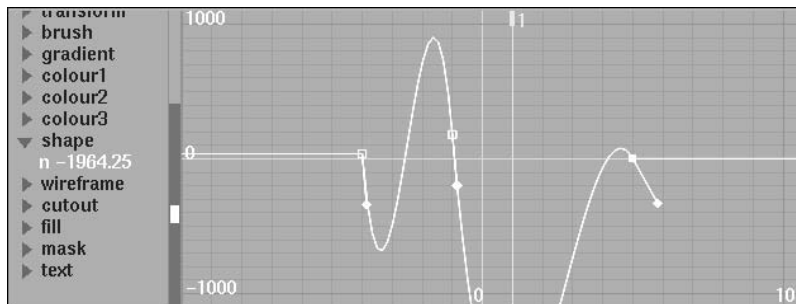

To animate the shape of an object:

- 1 Create an object.
This original shape becomes shape keyframe 1 in the Channel Editor.
- 2 Advance to another frame in the clip.
- 3 Select the object, and change its shape.
To change its shape, you must move, add, or delete a vertex on the object. This new shape is shape keyframe 2 in the Channel Editor.

Shape Interpolation

Use the Shape Interpolation box in the Setup menu to specify the interpolation between shapes in the animation.

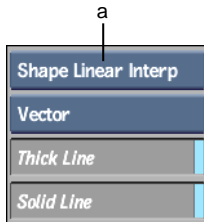

(a) Shape Interpolation box

Select:	To:
Shape Linear Interp	Produce sudden transitions between shapes.
Shape Cardinal Interp	Produce smooth transitions between shapes.

NOTE The type of shape interpolation you use is independent of the type of polygon interpolation you use.

Moving between Shape Keyframes

Use Previous and Next to move between shape keyframes in an animation.

To move between keyframes:

- 1 Select the object you want to modify.
- 2 Click Edit and then Shapes.
The Shapes menu appears.

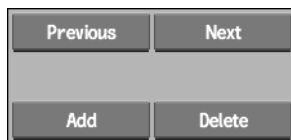

- 3 Click Next to advance to the next shape keyframe.
- 4 Click Previous to go to the previous shape keyframe.

Deleting Keyframes

Use Delete to delete a shape keyframe from the animation.

To delete a shape keyframe:

- 1 Select the object.
- 2 Click Shapes.
The Shapes menu appears.
- 3 Select the keyframe you want to delete.
- 4 Click Delete.
The selected shape is deleted.

Adding Keyframes

Use Add to create a shape keyframe. This can be useful for creating animations that start and end with the same shape.

To add a shape key using Add:

- 1 Select the object you want to animate.
- 2 Go to the frame where you want to add the shape keyframe.
- 3 Click Shapes.
The Shapes menu appears.
- 4 Click Add.
A new keyframe is added to the Shape channel in the Channel Editor.

Gradient Animation

Use the Channel Editor to animate the colours, orientation, and direction of a colour gradient. The Gradient folder includes Start and End folders for the two colours in the gradient. The Start and End folders each contain channels for the X and Y position of the colour, as well as the R, G, B, and alpha values.

Although you can animate the gradient independently, by default, the gradient will follow any transformations of the object.

To animate a gradient:

- 1 Select the object with the gradient you want to animate.
- 2 Click Animation. If necessary, swipe the cursor across the bottom of the screen to display the Channel Editor.
- 3 Click the Geometry and Stroke folders to expand them.
If you selected more than one object, a Stroke folder appears for each selected object. Click the Stroke folder for the object you want to animate.
- 4 Click the Gradient folder to expand it, and click the Start and End folders:
 - The Start folder contains the X and Y channels and a Colour folder for the gradient's colour.
 - The End folder contains the X and Y channels and a Colour folder for the gradient's colour.
- 5 Click to expand each Colour folder.

Use:	To:
x	Move colour origin left or right. This is the same as moving the gradient bar handle.
y	Move colour origin up or down. This is the same as moving the gradient bar handle.
r	Change percentage of red in the colour.
g	Change percentage of green in the colour.
b	Change percentage of blue in the colour.
a	Change percentage of the colour's alpha channel. Use this channel to create a gradient matte or to change the opacity of the colour.

- 6 Change the values for the channels in different frames to create a gradient animation.

Processing the Animation

To process the animation, click Process in the Graphics menu. Make sure you are at the first frame of the animation since the clip will be processed from the currently displayed frame until the end of the clip.

Saving and Restoring Objects

Use the Store and Recall commands to save and restore objects to the image. Use the Library menu to save or load graphics from the graphics library.

To save or load a graphic:

- 1 In the Paint menu, click Load or Save.
- 2 Select Geometry from the Load or Save option box.



(a) Save option box

- 3 Select a file or type in a name for the graphic.

NOTE If you are using Save and have typed in a name for the file, you must press **Enter** to finish saving the file.

The Store and Recall Commands

To save the selected graphic in the buffer, click Store in the Graphics menu. The current object replaces the graphic saved in the buffer.

The Store command does not save the result image. This means that if you tacked the objects onto the image, they are not saved using the Store command. To restore the geometry to the image, click Recall.

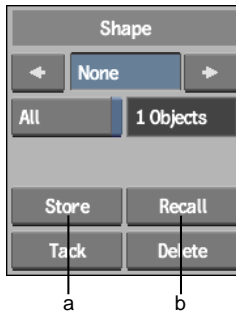

(a) Store button (b) Recall button

TIP Use Store and Recall to add graphics to clips loaded at a later time.

Tacking Down Objects

An object can be selected, deleted, edited, and transformed until it is tacked down on the image. As soon as it is tacked down, the object becomes part of the image and can no longer be manipulated.

There are several ways to tack down an object:

- Select a Tack mode so that an object is either tacked down as soon as it is drawn or as soon as the next object is drawn.
- Tack down selected objects only.
- Tack down all objects simultaneously using the Tack All command.

Tack Modes

The Tack mode is selected with the Tack Mode box in the Rendering Setup menu.

To set the Tack mode:

- 1 In the Paint module, click Setup.
The Setup menu appears.

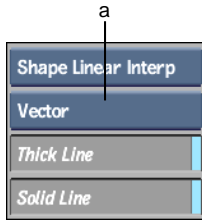

(a) Tack Mode box

2 In the Rendering area, select an option from the Tack Mode box.

Select:	To:
Vector	Explicitly tack down the objects using the Tack command.
Edit Last	Edit the last object drawn until the next object is added to the image. As soon as the next object is added, the last object is tacked down.
Raster	Tack down an object as soon as it is added to the image.

Tacking Down Selected Objects

When the Tack mode is set to Vector, objects must be explicitly tacked down on the image using the Tack button.

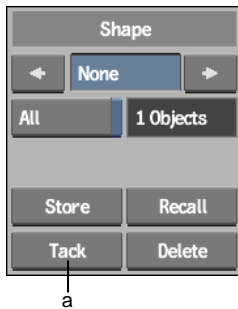

(a) Tack button

To tack down one or more objects:

- 1 Select the objects you want to tack down.

- 2 Click Tack.

All selected objects are tacked down on the image.

To tack down all objects on the image:

- 1 In the Graphics menu, Enable All.

- 2 Click Tack.

All objects are tacked down on the image.

Cutting and Pasting in Paint

88

Topics in this chapter:

- [Accessing the CutOut Menu](#) on page 2511
- [Creating a Cutout](#) on page 2512
- [Using the Cutout Commands](#) on page 2513
- [Increasing Editing Speed](#) on page 2516
- [Pasting Cutouts](#) on page 2517
- [Colour Correcting Cutouts](#) on page 2520
- [Animating Cutouts](#) on page 2521
- [Loading and Saving Cutouts](#) on page 2521
- [Preserving Paint Cutouts](#) on page 2522

Accessing the CutOut Menu

To access the CutOut menu, click the CutOut button in the Paint menu. Some options may be hidden if the colour palette is open. Swipe the cursor across the bar at the bottom of the screen to hide the colour palette.

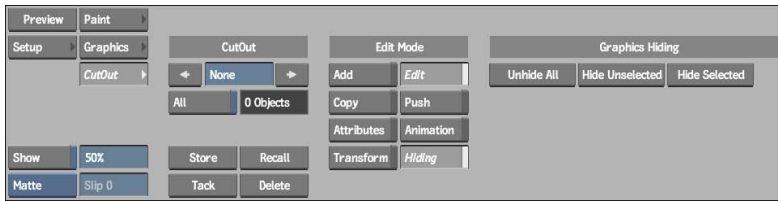

Creating a Cutout

Creating a cutout is similar to creating a graphic. In the CutOut menu, you use the same controls as you would in the Graphics menu to select, copy, hide, move, rotate, resize, delete, store, recall, push, and tack cutouts.

To create a cutout:

- 1 Click CutOut.
- 2 Click Add.

The CutOut Shadow options appear.

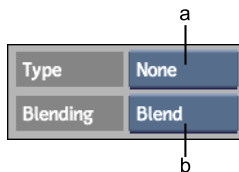

(a) Shadow Type box (b) Blending Mode box

- 3 To limit the area of the cutout with a matte, enable Use in the Matte controls.
- 4 Select an option from the Shadow Type box.
The Shadow Type box determines how the cutout will be pasted onto the result clip. See [Pasting Cutouts](#) on page 2517.
- 5 Click Attributes.
- 6 To create a cutout that spans the entire clip, enable Sequence.
- 7 Click one of the four Cutout commands. See [Using the Cutout Commands](#) on page 2513.

NOTE To use the GeoCut option, select all the objects you want to use in the cutout in the Graphics menu before clicking the GeoCut button.

- 8 Draw the cutout on the image.
- 9 Set the resolution to be used when updating the object.
The object appears at full resolution when it is drawn. See [Setting the Object Resolution and Display](#) on page 2490.
- 10 Set the cutout's position using the transformation box or controls.
- 11 Set the cutout's colour using the Current Colour pot.
- 12 Click Tack to permanently place the object on the result clip.
Once the object is tacked down, it cannot be moved, rotated, deleted, resized, or copied.

Keep Cut On

Once you add a cutout to the image, the default setting automatically switches from Cut mode to Edit mode. To prevent the switch to Edit mode, enable Keep Cut On in the Setup menu.

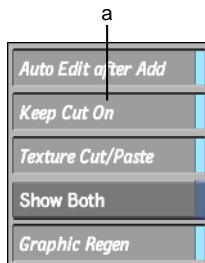

(a) Keep Cut On button

Using the Cutout Commands

Four commands are used to create cutouts: FrameCut, RectCut, PolyCut, and GeoCut. FrameCut, RectCut, and PolyCut create cutouts using shapes you define in the CutOut menu. GeoCut creates cutouts using objects you select in the Graphics menu.

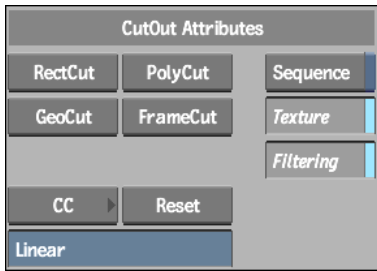

The FrameCut Command

Use the FrameCut command to make a cutout of the entire frame.

To create a cutout of an entire frame:

- 1 Click Add in the CutOut menu.
- 2 Click FrameCut.

The entire frame is cut out and pasted onto the image.

The RectCut Command

Use the RectCut command to cut and paste a single rectangular area of the image.

To use the RectCut command:

- 1 Click Add in the CutOut menu.
- 2 Click RectCut.
- 3 Draw a rectangle over the area of the image that you want to cut out.
The image area defined by the rectangle is copied and pasted onto the image.

The PolyCut Command

Use the PolyCut command to cut and paste a single polygonal area of the image.

To use the PolyCut command:

- 1 Click Add in the CutOut menu.
- 2 Click PolyCut.
- 3 Draw a polygon over the area of the image that you want to cut out.
The image area defined by the polygon is copied and pasted onto the image.

The GeoCut Command

Use the GeoCut command to create a cutout with objects you selected in the Graphics menu.

To create a cutout using GeoCut:

- 1 Click Graphics in the Paint menu.
- 2 Create any number of objects.
- 3 Select all the objects you want to use to make the cutout.
- 4 Set the opacity of the object(s) using the Brush Opacity field.
The opacity of the object(s) used in the cutout determines the transparency of the cutout. Use objects with a low opacity value to create an opaque cutout. Use objects with a high opacity value to create a transparent cutout.
- 5 Click CutOut in the Paint menu.
- 6 Click GeoCut.
The image area defined by the selected objects is copied and pasted onto the image.

Displaying Graphics and Cutouts

To display both the cutouts and the graphics objects in the CutOut menu, enable Show Both in the Setup menu. Although the graphics objects appear, they cannot be edited. Enabling Show Both also displays both the graphics objects and the cutouts in the Graphics menu. Although the cutouts appear, they cannot be edited.



(a) Show Both button

Increasing Editing Speed

To streamline cut and paste functionality, use Graphic Regen and Texture Cut/Paste in the Setup menu, and Texture in the CutOut menu.

The Graphic Regen Button

Disable Graphic Regen (regeneration) in the Setup menu to ensure the cutout always appears at the display resolution.

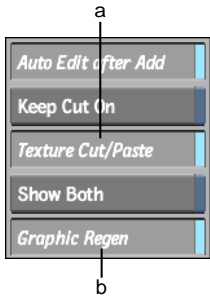

(a) Texture Cut/Paste button (b) Graphic Regen button

Texture Cut/Paste and Texture Button

Enable Texture Cut/Paste in the Setup menu or Texture in the CutOut menu to speed up cut and paste operations. These preferences are designed for platforms that support fast texture mapping.

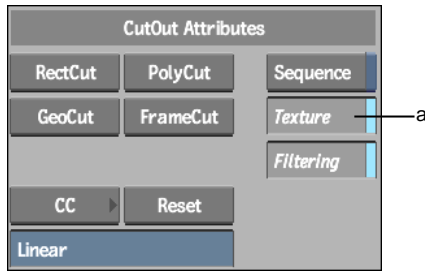

(a) Texture button in CutOut menu

The Filtering button can be used when Texture is enabled. Use Filtering to avoid image degradation as a result of recursive cutting and pasting. When Filtering is enabled, the image should not degrade.

Pasting Cutouts

Four options in the Shadow Type box are available for pasting a cutout onto the image.

Select:	To:
Emboss	Create an embossed cutout. See The Emboss Option on page 2517.
Extrude	Create cutout extrusions. See The Extrude Option on page 2518.
None	Use the blend functions available for pasting cutouts. See The Blend Options on page 2519.
Shadow	Add a drop shadow to the cutout. See The Drop Shadow Option on page 2520.

The Emboss Option

The Emboss option makes the cutout appear etched into the image. Shadows and highlights are added to simulate the effect of light shining on a raised object. Three layers are used to produce this effect:

- The top layer is a copy of the cutout in which the luminance values are increased by 50%. The top layer adds the highlights to the cutout.
- The middle layer is the cutout.

- The bottom layer is a copy of the cutout in which the luminance values are decreased by 50%. The bottom layer adds the shadow to the cutout.

Offset Field

Use the Offset field to specify the offset value in pixels for the three layers. The best results are obtained with values of 1 or 2.

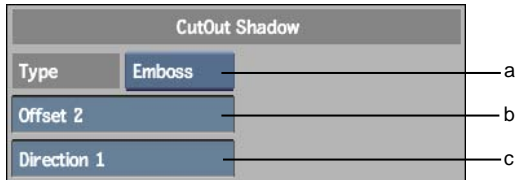

(a) Paste Mode box (b) Offset field (c) Direction field

Direction Field

Use the Direction field to specify the angle of the simulated incident light. The values range from 0 to 7 and specify the following angles of incident light.

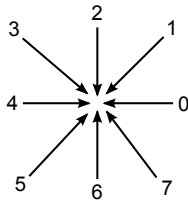

The Extrude Option

The Extrude option makes the cutout appear to pop out of the image by redrawing the cutout one layer on top of another. Each layer in the stack is offset slightly from the one below so only the edges of the layer are visible.

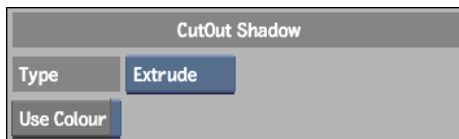

Editing the Layers

When you create a cutout using the Extrude option, two layers are created to produce the effect. There are vertices at the centre of each layer for manipulating the layer. You can change the depth and direction of the extrusion by moving either layer.

Changing the Colour of the Layers

Enable Use Colour to apply the current colour to the extrusion layers. The cutout image is used for the top layer only. When Use Colour is enabled, use the Brush Opacity field to set the transparency of the extrusion layers.

The Blend Options

The Blend options are similar to the commands in the Processing menu. They use the RGB values of the cutout and those of the result image. Select a blend option from the Blend Mode box.

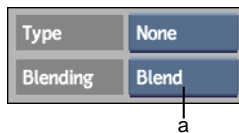

(a) Blend Mode box

Blend Pastes the cutout onto the result image.

Add Adds the RGB values of the corresponding pixels in the cutout and the result image. Values greater than 255 are clipped.

Subtract Subtracts the RGB values of pixels in the image from those of the cutout. Values less than 0 are clipped.

Black Pastes a black object in the shape of the cutout on the result image.

White Pastes a white object in the shape of the cutout on the result image.

Colour Pastes a coloured object in the shape of the cutout on the result image. The current colour is used for the object.

NAdd Min Compares the brightness values of corresponding pixels in the cutout and the result image, and uses the pixel with the smaller value in the tacked down cutout.

NAdd Max Compares the brightness values of corresponding pixels in the cutout and the result image, and uses the pixel with the greater value in the tacked down cutout.

Multiply Multiplies the RGB values of corresponding pixels in the cutout and the result image. The value is normalized by dividing the result by 255.

The Drop Shadow Option

You can add a drop shadow to a cutout by selecting the Drop option from the Paste Mode box. The drop shadow's colour is taken from the Current Colour pot.

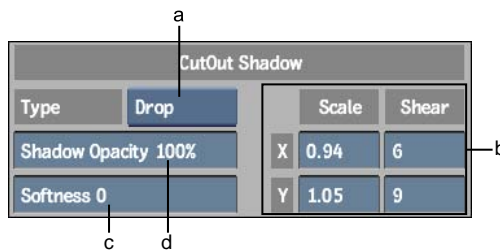

(a) Paste Mode box (b) Scale and Shear fields (c) Softness field (d) Shadow Opacity field

Shadow Opacity field Adjusts the transparency of the drop shadow. Decrease the value to increase the transparency.

Softness field Adjusts the edge softness of the drop shadow. Increase the value to increase the softness of the shadow.

Scale and Shear fields Shears and scales the drop shadow along the X- or Y-axis. These fields can be used to add lighting perspective to the image.

Colour Correcting Cutouts

Apply colour correction to cutouts using the Colour Correction field and CC in the CutOut menu. Click the Colour Correction field to load a setup directly from the colour correction library. Click CC to load the cutout into the Colour Corrector.

The default colour correction setup is Linear. When you load a different setup, the name of the setup appears in the Colour Correction field. To reset the colour correction setup, click Reset.

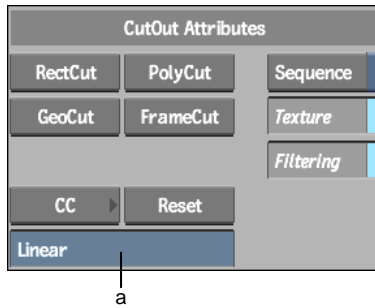

(a) Colour Correction field

Animating Cutouts

Use the Channel Editor to animate cutouts. To display the Channel Editor, click Animation and swipe the cursor across the bottom of the screen. For information on using the Channel Editor, see [Animation](#) on page 1963.

The following parameters can be animated for every cutout:

- Position, rotation, and shearing
- Brush attributes
- Colour (red, green, and blue channels)
- Emboss options
- Shadow options

Loading and Saving Cutouts

Use the Cutout Library to load and save cutouts.

To save or load a cutout:

- 1 In the Paint menu, click Save or Load.
- 2 Select CutOut from the Save or Load option box.
- 3 Select a file or type in a name for the cutout.

NOTE If you are using Save and have typed in a name for the file, you must press **Enter** to finish saving the file.

Preserving Paint Cutouts

Paint cutouts are saved in the Lost+_Found library on the Paint reel rather than in memory in order to conserve memory. During a session, you must not delete the Paint reel or its cutouts because they will be used when you return to Paint. However, you can safely delete the cutouts once you exit and restart the application because the Paint reel in the Lost+_Found library is not searched in subsequent sessions.

Topics in this chapter:

- [About Paint Setups](#) on page 2523
- [Saving Setups](#) on page 2524
- [Loading Setups](#) on page 2525
- [Deleting Setups](#) on page 2526
- [Creating and Saving Brush Setups](#) on page 2526
- [Creating a Custom Brush](#) on page 2527
- [Using Colour Correction Setups](#) on page 2534

About Paint Setups

A setup is a file that contains a record of all changes you make to a clip in a particular module. This record includes references to clips used. Setups let you save your work separately from the clips, so you can load and work on them any time, or apply the setup to other clips. Both the procedure and the interface involved in saving Paint setups and preferences differ slightly from those involved in saving setups in most other modules.

NOTE Custom brushes, brush sets, colour pots, and palette setups that you create in Paint are stored in your user directory. These resources are loaded when you specify a user in the Project Management menu.

Saving Setups

You can save pictures, preferences, mattes, palettes, brush groups, brushes, and stamps. You can also save cutouts, cut sequences, recorded strokes in AutoPaint, as well as geometry created in the Graphics menu.

To save a setup:

- 1 In the Paint menu, click Save.
- 2 Select the item you want to save from the option box.

Select:	To:
Picture	Save an image created in Paint.
Matte	Save the matte.
Palette	Save the current colour palette.
BrushSet	Save the current set of brushes.
Brush	Save the brush that is currently active.
Stamp	Save the Stamp currently in the Stamp window.
Geometry	Save the geometry created in the Graphics menu. This also includes all cutouts.
CutOut	Save the cutouts created in the CutOut menu.
CutSequence	Save the cutout sequence created in the CutOut menu.
AutoPaint	Save the last series of recorded strokes.
Preferences	Save current preferences.
Defaults	Save current default values.

The file browser appears, listing any existing setups for that item.

- 3 Type the name of the setup in the Save field.
- 4 Press Save (**Enter**) to save the setup.

Cropping a Setup

Use the crop box to limit the area of the picture, matte, cutout, or paint graphics to be saved in the setups directory.

To save a cropped matte, image, or cutout:

- 1 In the Paint menu, click Save.



- 2 Click Picture, Matte, or CutOut to specify the element from the image you want to save.
- 3 Draw the crop box on the canvas by pressing and dragging the cursor diagonally across the screen. Alternatively, use the left, right, top, and bottom Crop fields to set the boundaries of the crop box.

NOTE Click Reset to reset the crop box values.

- 4 Click Save.
- 5 Select the item you are saving from the option box and name the setup in the keyboard display.
If you want to overwrite an existing setup, select the filename from the file browser.
- 6 Press Save (**Enter**) to save the setup.

Loading Setups

Use the Load button to load any type of Paint setup.

To load a setup:

- 1 Click Load.
The Load Paint menu appears.
- 2 Select the type of setup you want to load from the Load option box.

A list of existing setups appears in the file browser.

- 3 Click the title or proxy of the setup you want to load.

Deleting Setups

Use the Delete button to remove setups from the setup directory.

To delete a setup:

- 1 Click Load.
The Load Paint menu appears.
- 2 Enable Delete.
- 3 Select the type of item you want to remove from the Load option box.
A list of existing setups appears in the file browser.
- 4 Click the title or proxy of the setup you want to remove and click Confirm.

Creating and Saving Brush Setups

Within a given brush set, there are five individual brushes. You can create and save five brush setups using the buttons numbered 1 to 5 in the Paint menu. Each brush setup saves the brush type, attribute values and modes, Special Effects medium, filter, fill parameters, and colour correction setups.

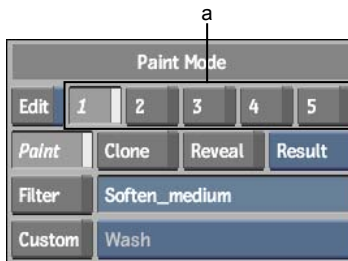

(a) Brush Setup buttons

To create and save a brush setup:

- 1 In the Paint menu, click one of the five Brush Setup buttons.

- 2 Enable Edit next to the Brush Setup buttons.
- 3 Set the brush attributes. See [Brush Attributes](#) on page 2428.
- 4 Disable Edit to save the changes to the selected brush setup.

NOTE To save a set of five brush setups, use BrushSet in the Save menu.

Copying Brush Setups

You can copy brush setups using the setup buttons.

To copy brush setups:

- 1 Select a setup using the Brush Setup buttons and enable Edit.
- 2 Press **Ctrl** and click another Brush Setup button to copy the setup.
- 3 Disable Edit to save the setup.

Creating a Custom Brush

With Paint, you can create your own custom brushes for specialized applications. You can modify an existing brush, draw your own brush shape, or grab a part of the image to use as a custom brush.

Use the Custom Brush menu to create your own brush. To display the Custom Brush menu, double-click one of the brush icons in the Brushes window. An enlarged view of the selected brush appears in the editing panel.

There are three ways to create a custom brush:

- Using the brush profile
- Drawing a brush shape in the editing panel
- Grabbing an area of the image

Changing the Brush Profile

The brush profile describes the size and edge softness of the custom brush. The default S-curve defines a circular airbrush. You can change the curve by

manipulating the two points that define the curve, or you can add points to the curve.

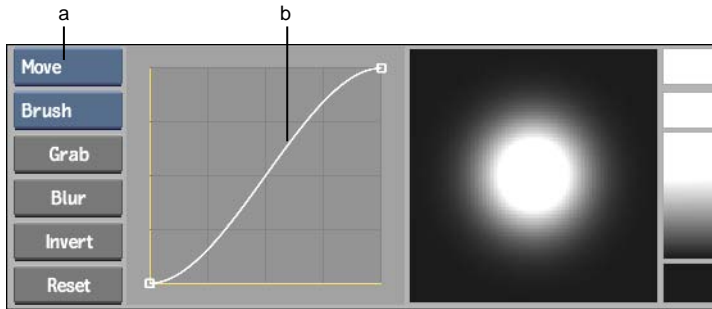

(a) Profile box (b) Brush profile

The profile does not affect the brush in the editing panel until you modify the curve or click the Update button.

Changing the Curve

By default, there are two points that define the brush profile. For the following table and examples, these points will be named A and B as shown in the preceding illustration. To move the points that define the curve, select the Move option from the Profile box.

Move:	To:
Point A up	Lighten the brush.
Point B down	Darken the brush.
Point A right	Harden the outer edge of the brush.
Point B left	Soften the middle of the brush.

To move the points only on the X-axis, select the Xscale option from the Profile box. To move the points only on the Y-axis, select the Yscale option. To break a point and manipulate its tangent, select the Break option and click on a point.

Adding Points to the Curve

To add points to the curve, select the Add option from the Profile box and click on the curve. To delete points from the curve, select the Delete option and click on one of the points on the curve.

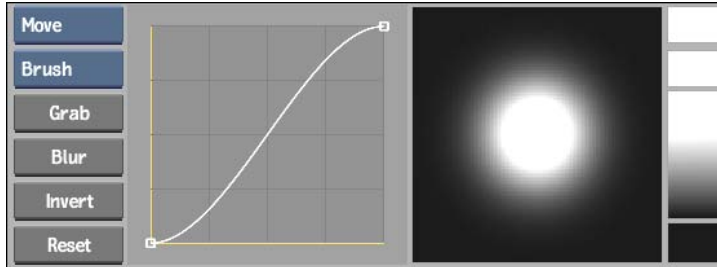

Default S-shaped curve

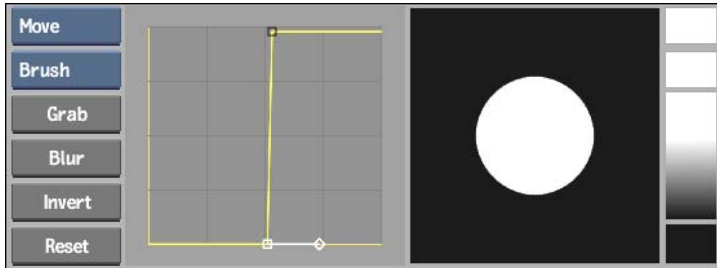

Hard edge curve

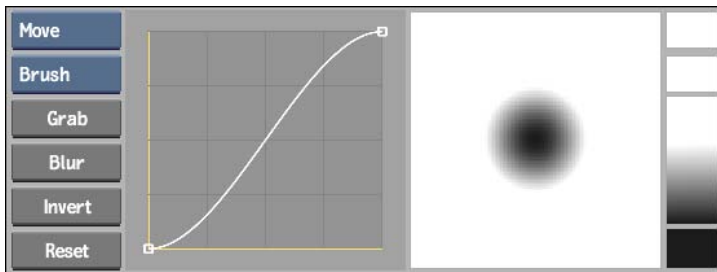

Invert brush curve

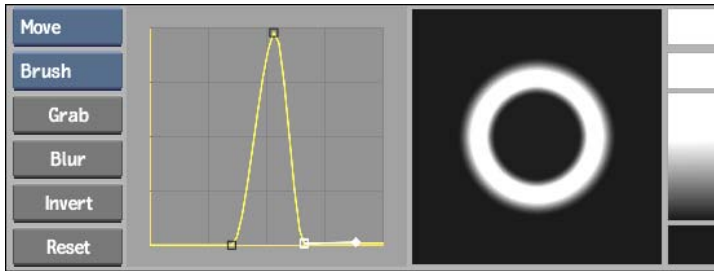

Ring-shaped brush curve

Drawing and Updating a Brush Shape

You can draw a new brush shape or update the current brush shape in the editing panel. The new shape is drawn using the brush that you selected to open the Custom Brush menu.

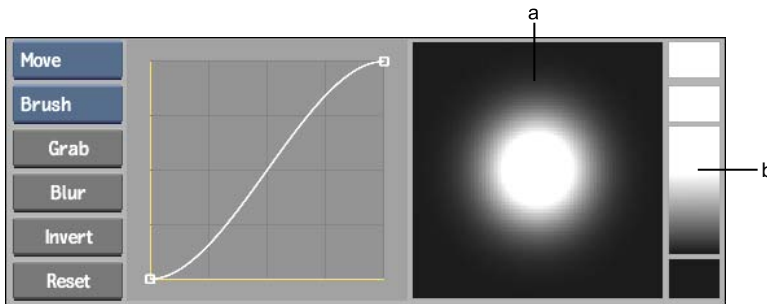

(a) Editing panel (b) Gradient bar

NOTE You cannot use the Undo command when drawing or updating a custom brush.

To draw a brush shape:

- 1 To create a new shape, erase the existing brush shape by painting over the editing panel.
- 2 Draw the new shape.
- 3 To invert the brush shape, click Invert.
- 4 To blur the brush shape, click Blur. Each time you click Blur, a 3 x 3 filter is applied to the brush image.

Selecting an Area of the Image

You can select an area of the image to use as the custom brush. The brush created from the selected area will be a square monochrome brush.

To grab an area of the image:

- 1 Click Grab in the Custom Brush menu.
- 2 Click on the image and drag across the screen to define the selection box.
To select a square area, press **P** as you sweep out the selection box.
The selected area appears as a monochrome image in the editing panel.
If the area that you select is not square, then the selected area is resized to fit in the editing panel.

Updating an Existing Brush

To update an existing brush, click the Update button. The changes are applied to the brush icon that you selected to open the Custom Brush menu.

Creating a New Brush

To create a new brush, click the New button. This creates an icon for the new brush shape and adds it to the Brushes window.

Saving the Custom Brush

Custom brushes are not saved automatically when you exit Paint. To save the updated or new brush for use in another work session, click the Save button. This opens the Brush setups directory. Use the keyboard to enter the name of the brush, and click the Enter button. The new brush is saved in the Brush setups directory.

Loading a Custom Brush

Click the Load button to load a custom brush from the Brush setups directory.

Customizing the Pressure Profile

Adjust the pressure profile to change the amount of pressure needed to paint with a given brush. The slope of the curve indicates how quickly paint is applied as you press on the tablet. If the curve is steep, a small amount of

pressure applies full paint to the canvas. If the curve is soft and rounded, you must press harder and longer to apply full paint.

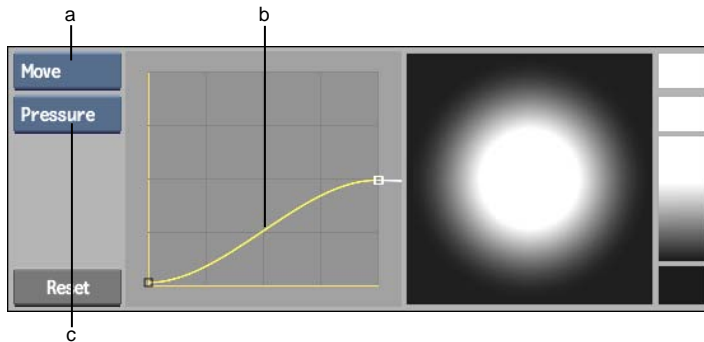

(a) Profile box (b) Pressure curve (c) Brush/Pressure box

You use the options in the Profile box to change and add points to the pressure curve. Click Load to load a Pressure profile. Click Save to save a custom pressure profile.

To edit the pressure profile:

- 1 Toggle the Brush/Pressure box to Pressure.
- 2 Double-click a brush icon in the Brushes window to display the Custom Brush menu.
- 3 Click the Brush/Pressure box to display the pressure profile.
- 4 Select Move from the Edit Mode box.
- 5 Press the left point (A) and drag it to its new position.
This changes the amount of paint the brush applies when you press lightly on the tablet.
- 6 Press the right point (B) and drag it to its new position.
This changes the amount of paint the brush applies when you press down firmly on the tablet.
- 7 Click Update to update the pressure profile for the brush.
The pressure settings will be used when you paint with the brush during the current work session.

Default Pressure Profile

Pressure is mapped along the horizontal axis (X-axis) of the curve, and the amount of paint applied is mapped along the vertical axis (Y-axis). If you are using the default S-shaped curve and you press lightly on the pen, very little paint is applied. As you press harder, more paint is applied.

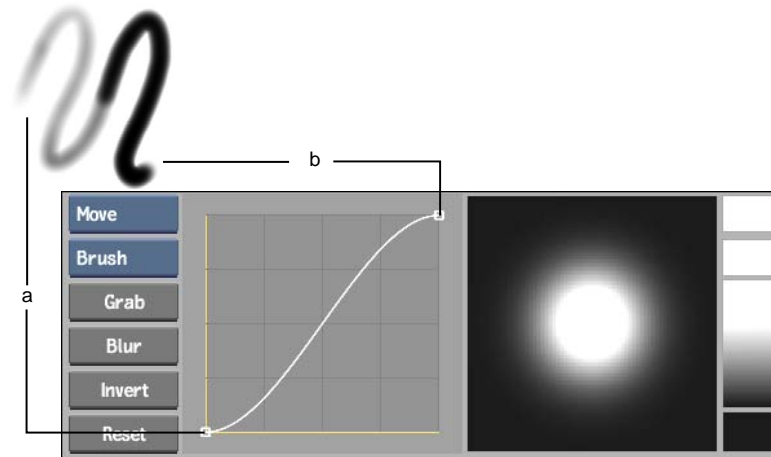

(a) Point A: Low paint at low pressure (b) Point B: Full paint at full pressure

Maximum Pressure Curve

If you move point A in the previous figure to the maximum position on the Y-axis, the curve results in full paint applied all the time, no matter how much or how little pressure you use.

Soft Airbrush

If you move Point B in the previous figure to a point midway on the vertical axis, the curve gives you a soft airbrush, even at full pressure.

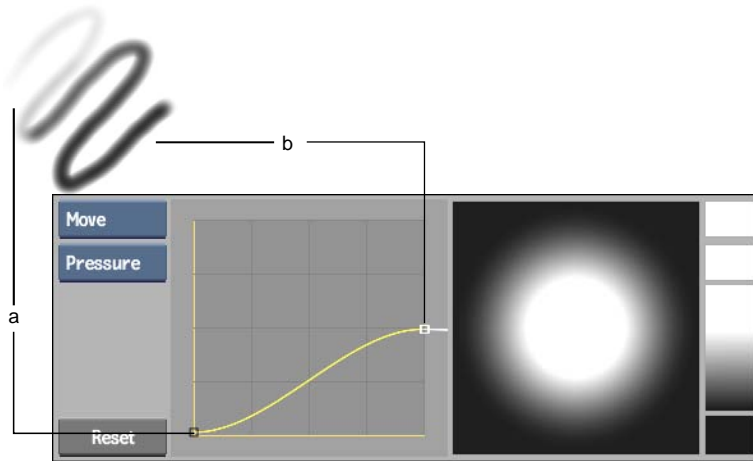

(a) Point A: Low paint at low pressure (b) Point B: Soft paint at full pressure

Using Colour Correction Setups

Use the Colour Correction Setup menu to apply colour correction setups to the clip loaded into Paint. You can bring the clip into the Colour Corrector or you can load a setup from the Colour Correction setups directory into Paint.

To load a clip into the Colour Corrector:

- 1 In the Paint menu, click Setup.
The Colour Correction menu appears.

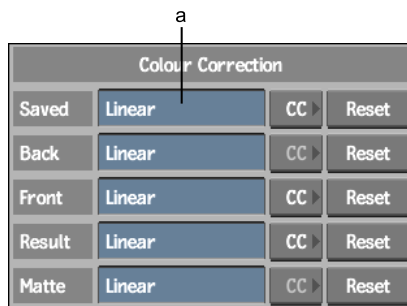

(a) Setup Name field

- 2 Click CC next to the clip you want to load into the Colour Corrector.

The Colour Corrector appears.

- 3 Use the Colour Corrector as described in [Colour Corrector](#) on page 1451.
- 4 Save the setup to the Colour Correction setups directory.
- 5 Click Exit.

The name of the Colour Correction setup appears in the Setup Name field beside the clip label for the selected clip.

To load a setup directly from the Colour Correction setups directory:

- 1 Click the Setup Name field for the clip you want to colour correct.
The file browser appears, displaying the contents of the Colour Correction setups directory.
- 2 Select the Colour Correction setup you want to use.

To reset the colour correction for a clip:

- 1 Click Reset beside the clip you want to reset.
- 2 Click Confirm.

Index

- _Edited_clip library 1192
- .rhosts file 886
- 12-bit partitions, using 898, 900
- 1D LUTs
 - See also* LUTs
 - about 730
 - creating 733
- 2-3 Pulldown
 - about 703
 - capturing inconsistent 708
 - configuration options 709
 - EDLs capture 708
 - importing EDLs 708
 - inserting on clip output 717
 - inserting on the Desktop 712
 - maintaining while exporting
 - EDLs 718
 - monitoring dual timecodes in the
 - Player 715
 - Options menu 333
 - removing on capture 705
 - removing on the Desktop 712
 - saving/loading tape list 710
 - tools 705
- 2D Histogram
 - node in Modular Keyer 1630
- 2D luma histogram, in Colour Warper 1493
- 2D vectorscope
 - in Colour Warper 1489
- 3-2 Pulldown
 - See* 2-3 Pulldown
- 3-point edits 1030
- 3D histogram in 3D Keyer 1665
 - display options 1682
 - displaying 1668
- 3D Keyer 1661
 - See also* nodes, keying, RGB Viewer, 3D histogram in 3D Keyer, ellipsoids, mattes, patches
 - colour values, plotting 1692
 - display options 1682
 - Lines button 1687
 - node in Batch 1332
 - patches, sampling 1678
 - patches, setting display
 - options 1685
 - Picking option box 1689
 - plotted points, displaying 1686
 - preferences 1706
 - steps for pulling a key 1662
 - updating images interactively while
 - sampling 1706
 - YUV softness 1676
- 3D LUTs
 - See also* LUTs
 - about 731
 - applying to image window 739
 - applying to Player 738
 - creating using scripts 735
 - processing clips with 742
- 3D models
 - deforming models 2296
 - importing in Action 2274
 - materials, 3ds Max import 2274
 - modifying, in Action 2278
 - particle generation, in Action 2327
 - projected textures 2289
 - specular highlight, in Action 2280
 - texture mapping, in Action 2284
 - transparency, in Action 2281
- 3D text
 - beveling 2303
 - creating in Action 2300
 - motion blur, in Action 2303
- 3D tracker
 - accessing in Action 2243
 - Analysis menu 2270
 - auto tracking in Action 2245
 - Camera menu 2248, 2265
 - converting results in Action 2253
 - Coordinates menu 2260

- exporting FBX 2229
- ground plane, defining in
 - Action 2252
- manual tracking in Action 2254
- Relations menu 2263
- Stabilizer, setting manual trackers 2254
- 3D vectorscope
 - in Colour Warper 1489
- 3ds Max
 - camera, in Action 2229
 - models, importing 2274
 - texture, replacing 2285
- 4-point edits 1031

A

- A/V sync, in Player 105
- A/V tools
 - previewing results 109
- AAF. *See* Advanced Authoring Format
- Action
 - 3D models, importing 2274
 - 3D text motion blur 2303
 - 3D text, creating 2300
 - 3D tracker, accessing 2243
 - 3D tracker, auto tracking 2245
 - 3D tracker, converting results 2253
 - 3D tracker, ground plane 2252
 - 3D tracker, manual tracking 2254
 - 3ds Max, importing models 2274
 - adding lights 2308
 - axes 2169
 - axes, stabilizing 2174
 - bicubic surfaces 2183
 - bilinear surfaces 2183
 - blending surfaces 2185
 - blurring media 2146
 - camera clipping planes 2227
 - camera, adding 2222
 - camera, modifying 2236
 - creating branches 2110
 - deformation mesh, adding 2296
 - deforming models and surfaces 2296
 - dividing media 2149

- duplicating objects 2112
- DVE Layer Objects 2155
- flipping normals 2318
- functions, using with particles 2354
- garbage masks as geometry 2305
- Geometry controls 2278
- grouping media 2207
- importing Photoshop files 2130
- loading clips 2089
- locking clips 2142
- Magnet Curve Editor 2194
- matte processing 2144
- Media list 2134
- media, changing 2141
- media, copying 2142
- media, cropping 2147
- media, deleting 2143
- menus, accessing 2102
- Modular Keyer, accessing 2152
- multitrack clip, loading 2092
- node bin 2097
- node in Batch 1333
- offsetting surfaces 2187
- OpenEXR support 2094
- particles, bouncing 2362
- particles, generating 2324
- particles, manipulating 2343
- particles, sample setups 2368
- planes 2173
- projector blend modes 2292
- replacing front or matte clip 2215
- schematic 2100
- schematic, multi-selection 2106
- selective lighting 2311
- setup options 2116
- setup, loading 2128
- setup, removing 2130
- shadows 2202
- slipping media 2149
- source nodes, applying effects 2214
- source nodes, cameras 2219
- source nodes, creating 2212
- source nodes, parenting 2213
- sources nodes, motion blur 2218
- specular highlights 2314
- stabilizing a clip 1794

- surface order 2204
 - surfaces, adding 2178
 - surfaces, applying media 2179
 - surfaces, characteristics of 2177
 - texture mapping 2284
 - transparency, 3D models 2281
 - wireframe, converting to 2317
 - working with Batch 1273
 - Z-buffer for shadows 2204
 - Z-Buffer option 2208
- acts
 - creating with EDLs 388
- Add
 - Logical Operation 1433
- Add Mesh button
 - in Warper 1882
- Add Pulldown node in Batch 1335
- adding
 - sources in Batch Paint 2377
- additive key
 - creating in Keyer 1600
 - creating in Modular Keyer 1645
- Adobe Type1 fonts, installing 874
- Advanced Authoring Format
 - about 481
 - exporting 483
 - importing 484
 - relinking to media 486, 489
 - supported effects 495
 - supported metadata 490
 - supported transitions 491
- advanced gradient
 - defined 1709
 - pickers, using with 1747
 - removing, in Tracer 1747
 - softness borders 1743
 - Tracer 1743
- ALE files
 - loading 341
- aligning
 - gestural edits 1022
- alpha channels
 - extracting 907
 - inserting 908
- Analyse button
 - in Warper 1893
- Anchor box
 - in Batch timeline 1163
- And
 - Logical Operation 1433
- AndInv
 - Logical Operation 1434
- AndRev
 - Logical Operation 1434
- animating
 - AudioDesk effects 1239
 - DVE Layer Objects 2162
 - garbage masks 1728
 - garbage masks with tracking 1735
 - in 3D Keyer 1701
 - in Keyer 1594
 - in Modular Keyer 1658
 - Paint strokes 1974, 2464
 - saturation in Colour Corrector 1972
 - shapes 2503
 - text 1941
 - Tracer 1752
 - transparency 1976
 - wipes 1094
- animation
 - Channel Editor 1964
 - channel hierarchy 1967
 - channels, framing 1992
 - channels, showing and hiding 1988
 - expressions, creating 2043
 - in Warper 1901
 - linking 2035
 - linking channels with
 - expressions 2045
 - motion paths 2023
 - previewing in Paint 2414
 - synchronizing 2031
 - Universal Channel Editor, in
 - Batch 2029
- Animation Curve window
 - accessing 1965
 - channel view 1968
 - translating curve 2012
- animation curves
 - adding keyframes to 2003
 - breaking and resetting keyframe
 - tangents 2015

- changing the colour of 2000
- copying 2001
- defined 1964
- extrapolation mode 1983
- framing keyframes 1992
- mattes, deleting in Colour Warper 1509
- moving 2012
- moving keyframes 2005
- negating 2020
- resetting tangents 2017
- reversing 2020
- selecting 2007
- anti-aliasing
 - in Compositor 1765
 - in Text 1913
 - in Warper 1908
- archives
 - appending entries to 648
 - browsing 642
 - clip library 634
 - closing 640
 - compact, about 635
 - compatibility 649
 - compatibility IRIX/Linux 16
 - desktop, saving from 638
 - estimating size of 615
 - file. *See* file archives
 - HDCAM, creating 623
 - header information slate. *See* VTR archives
 - in dual view mode 615
 - multi-tape, opening 633
 - normal, about 634
 - opening 631
 - recovering 653
 - restoring previous versions 650
 - saving clips to 634
 - structure 614
 - tape. *See* tape archives
 - upgrade compatibility 11
 - viewing using HTML TOC 643
 - VTR. *See* VTR archives
- archiving
 - choosing media for 604
 - clips with clip history 818
 - clips with different bit depths 608
 - configuring hardware for 610
 - configuring software for 612
 - menu, accessing 613
 - mixed resolution projects 608
 - preferences for restoring 650
 - setting keywords for 612
 - setups 655
 - soft-imported clips 629
 - tips for VTR 623
 - to HDCAM SR device 619
 - to USB/FireWire storage devices 629
 - using Linked mode 629
 - using Stone mode 629
 - workflow 609
- arrow keys
 - using in the Player 97
- ASCII table of contents, recovering an
 - archive 653
- Asian character sets 1925
- aspect ratio
 - changing 277
 - changing *See* resizing clips 667
 - forcing on import 698
 - of proxies 532
 - setting when resizing 665
- assembled clip
 - working with in Batch timeline 1017
- assembling
 - EDLs 386
- Assembly Options menu 324
- ATN files
 - loading 343
- audio
 - AAF, relinking to files 487
 - AAF, supported effects 495
 - AAF, supported transitions 491
 - animating AudioDesk effects 1239
 - Audio Timewarp options 1249
 - Auxiliary Effects 1241
 - Batch, editing 1288
 - Batch, playing 1317
 - capturing with EDLs 383
 - committing 312

- converting to another frame
 - rate 1252
- converting to another frame rate, in
 - Batch timeline 1164
- copying on desktop 1255
- creating fades 1209
- cutting clips, on desktop 945
- definitions 1196
- Dolby E 1198
- editing on desktop 940, 942
- exporting 259
- formats supported 195, 235
- importing 229
- input strip gain 1221
- limiting output strip 1248
- mixing down 1253
- muting in timeline 1208
- output strip gain 1247
- output strips 1246
- preferences 853
- scrubbing in modules 115
- scrubbing in Player 1203
- scrubbing in timeline 1205
- signal path, illustrated 1196
- sliding in timeline 1062
- slipping in timeline 1063
- soft effects 1214
- soloing in timeline 1208
- track patching, EDLs 384
- tracks, assigning 1205
- trimming in timeline 1059
- video sync in Player 105
- waveforms, viewing in
 - timeline 1207
- working with in timeline 1204
- audio filters
 - High Cut filter 1227
 - High Shelf filter 1226
 - Low Cut filter 1231
 - Low Shelf filter 1230
 - Mid Notch filter 1229
 - Mid Presence filter 1228
- Audio Mixdown tool 1253
- audio patching
 - in EDLs 362
- audio soft effects
 - Audio Timewarp 1219
 - Compression 1217
 - Delay Send 1214
 - EQ 1216
 - Gain 1215
 - Modulation Send 1214
 - Noise Gate 1218
 - Reverb Send 1215
- Audio Timewarp 1219
 - applying on a segment 1251
 - options 1249
- audio tone, creating 1248
- AudioDesk
 - accessing 1200
 - animating audio effects 1239
 - controls 1201
 - scrubbing audio 1203
- Auto button, in Warper 1887
- Auto Edit after Add 2477
- Auto Key
 - in Channel Editor 1971
 - in Compositor 1780
 - using with timewarps 1160
- Auto Matte
 - button, in Paint 2472
 - node in Batch 1336
 - Processing command 1426
- Auto mode, in Channel Editor 2017
- Auto Point 2499
- Auto Scale button 1160
- Auto Stabilize node in Batch 1336
- Auto Tangents mode
 - garbage masks, using for 1717
- Auto-Capture menu 378
- Auto-Connect
 - disabling 598
 - in network library 597
- automatic update, in Batch 1313
- AutoPaint 2457
 - playing recorded strokes 2464
 - Random mode 2460
 - recording brush strokes 2462
 - tracking 2463
 - User mode 2462
 - using graphics 2501

- Wipe mode 2458
- Auxiliary Effects
 - about 1241
 - adjusting settings 1245
 - Delay 1243
 - Modulation 1241
 - Reverb 1244
- Average
 - in Animation controls 2021
 - node in Batch 1339
- Average Over field 1429
- Average, Processing command 1426
- averaging
 - clips to simulate motion blur 1428
- Avid
 - exporting AAF 483
- axes, in Action 2169
- Axis Editor 1125
- Axis Keyer 1128
- Axis soft effect 1122
- Axis transition 1107

B

- background brightness
 - changing Colour Corrector 1458
- Background Import/Export Queue 300
- backups
 - Batch 1279
- Bake option, in Channel Editor 2015
- balancing
 - colours in Colour Warper 1510
- Batch
 - accessing options 1262
 - animating in 1273, 2029
 - audio context 1317
 - BFX View 1278
 - branch 1300
 - bypassing nodes 1303
 - Cache menu 1280
 - Cineon files, importing 1357
 - clip history nodes, naming 810
 - clip library, loading 1285
 - clips, adding 1285
 - copying nodes 1301
 - deleting nodes 1302

- DPX files, importing 1357
- executing from command
 - prompt 1328
- exporting 1322
- frames, start and end 1325
- library, loading clips 1285
- matching clips 1013
- menu described 1262
- missing media 1332
- modules, accessing 1272
- moving nodes 1301
- multiple node connections 1296
- naming nodes in groups 1308
- node bars 1266
- node bypass, disabling 1280
- node Setup menu, accessing 1272
- nodes and clips, connecting 1292
- nodes. *See* nodes, in Batch
- OpenEXR support 1332
- OpenEXR, adding clips 1287
- output or export name 1324
- outputting 1322
- previewing results 1313
- process trees 1322
- proxies, using 1286
- reference clip 1264
- rendering 1322
- rendering setups from UNIX
 - shell 1328
- resizing clips in 668
- resolutions, importing
 - multiple 1286
- saving edited clips 1188
- schematic 1270
- selecting nodes 1300
- Setup menu 1278
- setups, saving and loading 1266
- status in a text file 1279
- status via web page 1279
- timeline, creating dissolves 1078
- Timing View 1274
- undo 1313
- Universal Channel Editor,
 - defined 1273
- update clip display 1278
- variables in scripts 1326

- viewing options 1265
- workflow 1262
- workflow, motion estimation 1176
- working in Action 1273
- Batch FX
 - BFX Output node 1339
 - bringing nested setups to current level 1417
 - converting soft effects to nodes 1388
 - copying setups 1419
 - copying soft effects to schematic 1396
 - creating 1376
 - creating one clip per timeline layer 1386
 - defined 1375
 - deleting setups 1420
 - editing setups 1409
 - matching sources 1413
 - navigating setups 1410
 - outputting a matte 1402
 - previewing unrendered setups 1420
 - viewing in context 1397
- Batch Paint
 - accessing 2374
 - brush attributes, setting 2382
 - canvas, wiping 2401
 - canvas, clearing strokes 2400
 - cloning 2394
 - custom brushes, using 2392
 - reference image overlay 2402
 - saving setups 2404
 - sources, clearing strokes 2378
 - sources, displaying reference image overlays 2381
 - sources, locking 2381
 - sources, removing 2378
 - sources, revealing 2396
 - sources, deleting a node 2378
 - strokes, applying 2388
 - strokes, blending with current image 2398
 - strokes, clearing 2378
 - strokes, hiding 2379
 - strokes, limiting with matte 2389
 - strokes, limiting with source matte 2380
- Batch timeline
 - accessing 970
 - backup of clips 1192
 - creating one clip per layer 1386
 - displaying head frames 1400
 - Edited (_Edited_) clip library 1192
 - editing 928
 - elements, swapping 1012
 - offsetting frames 1400
 - record timecode 1400
 - source and record clip, setting 1019
 - timewarps, creating and modifying 1160
 - toggling between source and record clip 1021
 - workflows 1016
- Batch, Processing command 1426
- Bezier curves
 - for polygons 2500
- BFX Output node in Batch 1339
- BFX View 1278
- bicubic surfaces
 - in Action 2183
- bilinear surfaces
 - in Action 2183
- bit depth
 - changing 277
- blacking VTR tape 160
- blacking VTR tape. *See* outputting, clips in assemble mode
- Blend Editor 1136
- Blend Mode, in Action 2185
- blend nodes 1611
 - Basic Blend method 1652
 - CBlend 1648
 - Current Layer proxy 1655
 - Curves Blend method 1652
 - layers, changing order 1656
 - layers, creating 1654
 - layers, renaming 1656
 - matte, adding 1651
 - MBlend 1649
 - pipes, bypassing 1657
 - pipes, defined 1611

- Blend soft effect 1136
 - blending 2398
 - between fields in interlaced video 727
 - front and back clips in Keyer 1590
 - front and back clips in Master Keyer 1553
 - front and back clips in Modular Keyer 1652
 - blur filter
 - in Batch 1370
 - Blur medium 2440
 - blurring
 - colour images in Batch 1370
 - colour images in Modular Keyer 1631
 - edges of matte in Modular Keyer 1637
 - with Gaussian blur in Colour Warper 1508
 - bookmarks
 - in file browser 86
 - boxes, selecting options from 36
 - Break mode, in Channel Editor 2015
 - broadcast monitor
 - preferences 830
 - browser. *See* file browser
 - brush attributes 2428
 - Direction 2384, 2431, 2434
 - Jitter 2384, 2431
 - modes 2433
 - Opacity 2382, 2428
 - Pressure 2383, 2430, 2435
 - Rate 2382, 2429
 - Roll 2385, 2432
 - Size 2382, 2429
 - using reference images 2433
 - Brush Spacing preference 2435
 - brushes
 - See also* special effects media
 - attribute modes, setting in Batch 2386
 - attributes, setting in Batch Paint 2382
 - custom 2527
 - selecting 2420
 - setups, saving and loading 2526
 - strokes, applying 2388
 - types 2420, 2477
 - Burn
 - using for processing 305
 - Burn In
 - Format command 1445
 - Burn In Letterbox
 - node in Batch 1341
 - Burn In menu
 - about 425
 - Burn In Timecode node in Batch 1342
 - burning in
 - timecode and keycode 428
 - buttons
 - determining hot key for 865
 - using 35
 - bypassing
 - disabling in Batch 1281
 - EQ 1237
 - nodes in Batch 1303
- ## C
- cache
 - Batch, using 1319
 - tab on node 1293
 - tab states 1320
 - calculator
 - about 68
 - using with keycode 410
 - using with numbers 69
 - using with timecode 70, 409
 - camera
 - adding in Action 2222
 - clipping planes, in Action 2227
 - depth of field, in Action 2228
 - exporting, in Action 2229
 - importing, in Action 2229
 - modifying in Action 2236
 - zooming, in Action 2236
 - canvas
 - clearing strokes 2400
 - rotating 2401
 - wiping 2401

- Canvas button
 - in Paint 2419
- Capture group 352
- capturing
 - See also* recapturing
 - inconsistent pulldown 708
 - live video signal 163
 - single frame, from a VTR 151
 - with 2-3 Pulldown removal 705
- catalogues
 - hot key 866
- CBlend
 - node in Modular Keyer 1648
- CBlend node
 - adding a matte 1651
- CD-ROM drives, detecting 90
- Change Frame Mode Code tool 416
- Change Keycode tool 415
- Change TC / KC / Rate
 - Format command 1445
- Change TC/KC/Rate tools 413
- Change Timecode tool 413
- Channel Editor 1964
 - Auto Key 1971
 - Auto mode 2017
 - automatically selecting
 - channels 1990
 - Break mode 2015
 - breaking and resetting
 - tangents 2015
 - collapsing channels 1986
 - deleting keyframes 2004
 - display options 1985
 - expanding channels 1986
 - filter, working with
 - preferences 1991
 - framing channels 1992
 - hiding channels 1988
 - hiding tangents 1989
 - linking channels with
 - expressions 2045
 - moving keyframes 2005
 - Pan mode 1999
 - particle parameters 2336
 - Select mode 2007
 - selecting keyframes and
 - channels 2007
 - selection sets 1995
 - showing channels 1988
 - Universal Channel Editor, in
 - Batch 2029
 - viewing channels 1985
 - Zoom mode 1999
- channels
 - collapsing 1986
 - defined 1964
 - editing properties 1972
 - expanding 1986
 - framing keyframes 1992
 - hiding 1988
 - hierarchy 1967
 - selecting 2007
 - showing 1988
 - views, accessing in multiple
 - viewports 1970
- chroma
 - modifying with Processing
 - commands 1441
 - modifying without affecting the
 - luma 1527
- chroma key
 - directly on the timeline 1128
- Cineon images
 - converting 906
- clamping
 - colours in the Colour Warper 1484
- Cleaner XL
 - exporting to 264
- clearing
 - canvas 2400
 - strokes, sources 2378
- clip
 - defined 292
- clip history 807
 - committing clips 817
 - compatibility between products 818
 - deleting intermediates and
 - sources 815
 - effect information, viewing 809
 - managing clips 813

- managing sources and intermediates 813
- modifying in Batch 810
- naming nodes 810
- opening last module used 809
- saving and archiving 818
- searching 814
- clip I/O
 - See also* clips and/or capturing
 - monitoring video during 161
 - naming clips and tapes for 150
 - using HSDL device 187
 - using software initialization
 - configuration file for 145
 - using VTR, general workflow 144
- clip libraries
 - AAF, recapturing to material 489
 - adding comments to clips in 579
 - archiving 634
 - auto-connecting 597
 - backward compatibility 14
 - Batch backups 1192
 - Batch, accessing from 1356
 - Batch, adding clips 1285
 - black frames 880
 - creating 557
 - deleting 590
 - differentiating between entries
 - in 575
 - displaying clip information in 575
 - dual view 559
 - exiting 559
 - expanding and collapsing entries
 - in 573
 - handling entries with the same name 562
 - List View mode 571
 - loading clips 593
 - loading clips from local and remote projects 598
 - loading entries to desktop 591
 - Lost+Found clip library 880
 - moving contents in 586
 - opening 558
 - organizing clips in 584
 - reels and desktop entries,
 - adding 585
 - remote, accessing 593
 - renaming entries in 588
 - renaming tapes in 578
 - resizing clips 593
 - saving clips to 561
 - selecting entries from 580
 - selecting local and remote 597
 - sharing between products 14
 - sorting in List View mode 577
 - sorting titles and proxies 572
 - structure 564
 - upgrade compatibility 11
 - viewing clip information 564
 - viewing modes 567
 - viewing proxies 568
 - viewing titles 567
- clip libraries, troubleshooting lock files 600
- clip library tools
 - Consolidate 311
 - Publish 297
 - Resize 665
- Clip Media group 202
- Clip Metadata group 204
- clips
 - adding comments to 579
 - adding glow effects 1778
 - adding notes to 53
 - applying commands on the desktop 43
 - Batch, adding 1285
 - Batch, applying LUTS 1288
 - Batch, information in 1267
 - Batch, used in 1260
 - caching in Batch 1319
 - capturing using EDLs 380
 - changing the default scan mode 721
 - collapsing on the desktop 48
 - colours, sampling 73
 - commands to the same, applying 44
 - compacting in clip libraries 313
 - consolidating in clip library 311
 - consolidating, on desktop 963
 - copying frames in, on desktop 958

- copying in clip library 587
- copying on the desktop 64
- cutting, on desktop 943
- deinterlacing 726
- deleting from a project 539
- deleting on the desktop 66
- desktop, navigation on 45
- displaying information 575
- displaying timecode and
keycode 408
- dividing into smaller clips using
Format commands 1448
- expanding on the desktop 48
- finding clips that use a specific
frame 912
- flipping 1432
- frame, go to on the desktop 51
- generating proxies on input 153
- input using a VTR 146
- input using HSDL device 189
- inserting 2-3 Pulldown on
output 717
- inserting frames into clips on
desktop 951
- inserting in edit sequence 1025
- inserting into other clips, on
desktop 951–952
- interlacing 727
- jogging 571
- key-in clips, defined in Keyer 1546
- key-in clips, represented in RGB
Viewer 1666
- Library node, copying to desktop
from 1279
- loading and resizing 593
- loading from another project 598
- loading in Player 94
- loading the same into a module 44
- loading to desktop 591
- locking duration 2408
- locking on the desktop to prevent
changes 56
- matching 1013
- matching with sources, on
desktop 956
- merging fields 727
- metadata 556
- mixing, on the desktop 1075
- modules, loading 108
- modules, loading into 43
- moving in clip libraries 586
- naming on the desktop 58
- output in assemble mode 161
- output to a VTR 153
- output using HSDL device 191
- playing in modules 111
- playing in Player 94
- playing on the desktop 45
- processing 305
- reformatting 273
- removing conflicts in keycode 425
- removing conflicts in timecode 425
- renaming tape 578
- replacing frames in, on desktop 954
- reversing field dominance 723
- reversing frame order, on
desktop 959
- Same Clips option 110
- saving to archives 634
- saving to clip library 561
- scrubbing on the desktop 49
- searching the desktop 77
- selection order numbers 581
- sharing between products 15
- shortcuts for saving 563
- soft-imported 200
- soft-imported, archiving 629
- soft, committing in clip
libraries 312
- splicing, on desktop 948
- strobing 1173
- timecode on the desktop,
copying 65
- trimming in timeline 1054
- unlinking media from 270
- unlocking duration 2408
- using Reformat tool 277
- versioning with subtitle XML 468
- viewing information about 564
- Clone medium 2441
- cloning
in Batch Paint 2394

- cmtool utility 890
- collapsing
 - clips on the desktop 48
 - entries in clip libraries 573
 - image sequences in file browser 88
- Colour
 - Frame Mode 1443
 - source, creating custom with
 - Processing commands 1442
- colour balance, adjusting in Colour Corrector 1473
- colour casts, creating in Colour Warper 1527
- Colour Correct
 - node in Batch 1342
 - node in Modular Keyer 1633
 - Processing command 1427
- colour correcting
 - clamping in Colour Warper 1484
 - colour balance, adjusting 1473
 - Colour Correction Editor 1134
 - colour values, remapping 1479
 - colours, readjusting after correction in Colour Warper 1528
 - contrast in Colour Warper 1515
 - contrast, adjusting 1469
 - contrast, decreasing 1477
 - contrast, increasing 1476
 - cropping correction area in Colour Warper 1496
 - deleting from current frame 1509
 - deleting in Colour Warper 1509
 - desaturation in Colour Warper 1517
 - front clip when keying 1593
 - gamma, adjusting 1471
 - highlights 1467
 - hue, adjusting 1468, 1473
 - imbalances in Colour Warper 1510
 - in Action 2150
 - in Colour Corrector 1467
 - in Colour Warper 1495
 - in Modular Keyer 1633
 - in Paint 2534
 - inverting mattes in Colour Warper 1498
 - luma ranges, defining 1478
 - matching colours 1465
 - matching in Colour Warper 1523
 - mattes and selectives, resetting in Colour Warper 1508
 - midtones 1467
 - monochrome images,
 - converting 1470
 - negative images, converting 1470
 - offsets, adjusting 1472
 - removing unwanted colours in Colour Warper 1511
 - resetting values individually in Colour Warper 1499
 - result clip when keying 1592
 - sampling colours 1462
 - sampling in Colour Warper 1501
 - saturation, adjusting 1468
 - shadows 1467
 - soft effect, colour correction 1134
 - spills, removing in Colour Warper 1529
 - suppressing colours 1472
 - suppressing colours in Colour Warper 1515
- Colour Corrector
 - about 1451
 - accessing from Action 2150
 - accessing from Compositor 1775
 - accessing from other modules 1453
 - background brightness,
 - changing 1458
 - clips, loading 1452
 - clips, viewing 1455
 - colour curves 1480
 - colour patches 1462
 - crop box 1458
 - cutouts 2520
 - gain 1472
 - histogram 1475
 - input levels 1476
 - Match button 1465
 - menu, hiding 1455
 - output levels 1477
 - processing 1481
 - resetting 1460

- RGB channels, rewiring 1469
 - setup options 1457
 - setups and preferences,
 - saving 1462, 1500
 - updating images interactively 1457
- Colour Curves
 - node in Batch 1342
 - node in Modular Keyer 1633
- colour models
 - selecting to key with in Keyer 1563
- Colour Noise
 - Frame Mode 1443
- colour palette
 - colour gradient 2414
 - in Paint 2412
 - mixing colours 2412
- colour picker
 - about 71
 - channel sliders, using the 72
 - colour pots, using the 75
 - mixing colours 76
 - mixing palette, using the 76
 - sampling an average colour along a path 74
 - sampling an average colour from a selection box 75
 - sampling colours from clips 73
 - setting colour channel values 72
 - storing colours in the colour pots 75
- colour pots 40
- colour spill
 - removing in Colour Warper 1529
 - suppressing in Keyer 1584
 - suppressing in Master Keyer 1551
- Colour Warper 1483
 - accessing from Colour Corrector in Batch 1485
 - colour correcting 1495
 - node in Batch 1344
 - node in Modular Keyer 1635
 - reference clips, viewing 1488
 - resetting colour corrections 1498
 - setting undo levels 1500
 - setting up the work environment 1488
 - subsets 1531
 - viewports, displaying 1488
- Coloured Frame
 - node in Batch 1343
- Coloured Frame, Processing
 - command 1427
- colourspace conversion
 - enabling on clip I/O 181
- Combine
 - Format command 1446
 - node in Batch 1344
- combining
 - RGB channels using Format command 1447
- command line utilities. *See* utilities
- command prompt
 - Batch, executing from 1328
- commands
 - start-up options 920
- comments
 - adding to cue marks 1010
 - adding to segment marks 1010
 - adding to timeline 986
- Comments group 352
- Commit button
 - in Editing menu 965
- Commit tool 312
- committing
 - clips on desktop 965
 - clips on the timeline 1182
 - clips with history 817
 - soft clips 932
 - soft clips in clip libraries 312
- compact archives, about 635
- Compact tool 313
- compacting
 - clips in clip libraries 313
 - soft effects 1186
- compatibility
 - backward 13
 - between products 14
 - clip history 818
 - Linux/IRIX 16
 - upgrade 10
 - with 3ds Max 17
 - with Combustion 16
- complex publish 292

- compositing
 - with Action 2087
 - with Quick Composite 1777
- Compositor
 - colour correcting from 1775
 - loading the clips 1764
 - tracking 1774
- compound
 - images, creating using Processing commands 1431
- Compound
 - node in Batch 1345
- Compound, Processing command 1426
- Compression 1217
- configuration file
 - See also* software initialization configuration file
 - FontMapping keyword 1925
 - selecting 537
 - template 537
- Configuration Template box 537
- Consolidate button
 - in Editing menu 963
- Consolidate tool 311
- consolidating
 - clips in clip library 311
 - clips on desktop 963
 - timeline elements 1181
- Constant shape, for garbage masks 1712
- constant timewarps 1157, 1161
 - editing 1163
- containers
 - creating on timeline 1041
 - mattes, creating 1123
- contexts
 - audio 1317
 - defined 1315
 - video 1315
- contrast
 - adjusting in Colour Corrector 1469
 - decreasing in Colour Corrector 1477
 - gamma, adjusting in Colour Warper 1518
 - increasing in Colour Corrector 1476
 - saturation, adjusting in Colour Warper 1517
 - shadows and highlights, adjusting in Colour Warper 1516
- conventions, in users guide 4
- converting Cineon images 906
- Copy button
 - in Warper 1895
- copying
 - Batch, nodes and process trees 1299
 - clips from an edit sequence 1032
 - clips on the desktop 64
 - DVE Layer Objects 2161
 - keycode 421
 - objects in Paint 2488
 - setups 528
 - text attributes 1933
- crawls, text 1937
- Create Sub Dir button 296
- creating
 - 1D LUTs 749
 - EDLs 349, 360
 - projects 526
 - users 546
- credits
 - creating a text roll 1939
- crop
 - in Action 2147
- Crop Auto option 1768
- crop box
 - changing border colour in Colour Warper 1497
 - creating in Colour Corrector 1458
 - disabling in Colour Warper 1497
 - hiding in Colour Warper 1498
 - in Compositor 1767
 - in DeGrain/Regrain 794
 - in Keyer 1596
 - in Modular Keyer 1627
 - in Resize 682
 - using in Colour Warper 1496
- cropping
 - colour correction area 1496
 - in Action 2147
 - in Resize 687
- crossfades
 - creating on the desktop 1071

- current colour
 - in Paint 2411
- cursor 41
 - gestural editing on desktop 939
 - trim 1046, 1063
 - trim, in timeline 1051
- curves
 - extrapolation 1983
 - interpolation 1981
- custom brushes, in Batch Paint 2392
- custom nodes 1309
- custom particles 2336
- Customer support, contact 7
- Cut button
 - in Editing menu 943
- Cut mode 1103
- cutouts
 - adding drop shadows 2517
 - animating 2521
 - blending 2519
 - colour correcting 2520
 - drop shadows 2520
 - embossing 2517
 - extruding 2518
 - FrameCut 2514
 - GeoCut 2515
 - Keep Cut On 2513
 - PolyCut 2514
 - RectCut 2514
 - soft, defined 932
- cuts
 - See also* splice
 - adding to timeline 1011
 - soft, defined 930
- cutting
 - clips on desktop 943
 - clips on desktop with audio,
 - gesturally 947
 - clips on desktop, at splices 944
 - clips on desktop, every nth
 - frame 944
 - clips on desktop, gesturally 946
 - clips on desktop, with audio
 - tracks 945
 - dissolves and timewarps, on
 - desktop 945

D

- darwing. *Seepainting*
- Deal
 - Format command 1446
 - node in Batch 1345
- dealing
 - clips 1448
- default
 - directories 800
 - preferences 805
- Default Resolutions list 699
- Deform
 - in Action 2296
- deformation mesh
 - adding, in Action 2296
- Degrain
 - node in Modular Keyer 1640
- DeGrain
 - Processing command 1427
- DeGrain tool, using 775
- degraining clips
 - in Batch 1345
- Deinterlace
 - Format command 1445
- DeInterlace
 - Format command 726
 - node in Batch 1346
- Delay 1243
- Delay Send 1214
- Delete button
 - in Warper 1882
- Delete mode
 - in Channel Editor 2004
- deleting
 - all clips associated with a
 - project 539
 - archive table of contents 647
 - clips on the desktop 66
 - desktops 67
 - file browser, in 89
 - nodes in Batch 1302
 - projects 539
 - setups 539
 - source nodes 2378
 - users 549

- deleting. *See* extracting, removing, lifting
- Depth of Field button
 - in Action 2228
- Desk
 - node in Modular Keyer 1621
- Desk node
 - slipping clips in the Modular Keyer 1623
- desktop
 - applying commands to clips 43
 - autosave 34
 - black frames 880
 - clearing before loading 592
 - clips, loading into modules 43, 108
 - collapsing clips 48
 - copying clips 64
 - deleting 67
 - deleting clips 66
 - expanding clips 48
 - frame, go to 51
 - loading 591
 - locking clips to prevent changes 56
 - Main menu 32
 - naming 59
 - naming clips 58
 - naming reels 59
 - navigating clips 45
 - playing clips 45
 - preferences 848
 - reels 55
 - saving 561, 563
 - scrubbing clips 49
 - searching for clips 78
 - searching for matching frames 81
 - Sparks, using 1959
 - timecode, copying 65
 - undoing and redoing commands 68
- desktop editing 928
- Destination settings menu 682
- Detect button
 - in file browser 90
- developing
 - Sparks 1960
- Difference
 - Logical Operation 1434
 - matte, generating 1437
 - Processing command 1426
- Difference Matte
 - node in Batch 1346
 - node in Modular Keyer 1635
- Direction brush attribute 2384, 2431, 2434
- directories 800
 - accessing 800
 - default 801
 - loading preferences 803
 - loading setups 803
 - removing multiple setups from 805
 - removing preferences 804
 - removing setups 804
 - saving setups and preferences to 803
- directories, creating 89
- disk testing utility 882
- Display group 355
- displaying, sources as overlays 2381
- Dissolve Editor
 - on the desktop 1073
- dissolves
 - copying and pasting in
 - timeline 1109
 - creating complex, on the
 - desktop 1073
 - creating mixed clips 1076
 - creating on desktop 1066
 - creating on timeline 1078
 - cutting on desktop 945
 - Dissolve Editor from timeline,
 - accessing 1082
 - force rendering on desktop 967
 - in EDLs 365
 - trimming in timeline 1058
 - types of, on the desktop 1067
- Dissolves
 - Mix Editor, accessing 1077
- Distort
 - adding nodes in the schematic 1846
 - animating splines 1855
 - blending clips 1858
 - copying tracking data 1858
 - correspondence points 1860
 - displaying clips 1832
 - drawing splines 1834

- editing splines 1839
 - linking nodes for source
 - interpolation 1853
 - loading clips 1825
 - morphing workflow 1824
 - node in Batch 1347
 - schematic 1841
 - setups, saving and loading 1876
 - source interpolation, using 1859
 - Stabilizer, loading clips 1856
 - tracking and stabilizing 1856
 - tracking by axis 1856
 - tracking by vertices 1857
 - transforming splines 1840
 - warping and morphing 1822
 - warping workflow 1822
 - DL Tools. *See* utilities
 - DLEDLs
 - about 319
 - editing 370
 - structure 371
 - documentation
 - accessing 834
 - online 5
 - Dolby E
 - about 1198
 - Dominance
 - Format command 1445
 - dominant field. *See* first active line
 - DPX files
 - exporting 249
 - importing 213
 - DPX Transfer Characteristics group 242
 - drag and drop
 - using in clip libraries 586
 - Drag medium 2442
 - drop shadows
 - adding to cutouts 2517
 - in Action 2202
 - dual library view
 - in archives 615
 - using 559
 - dual-serial link I/O, configuring 184
 - Duplicating in Action 2112
 - DVE Layer Object
 - adding in Action 2156
 - animating 2162
 - copying 2161
 - expanding in the schematic 2159
 - instancing 2161
 - navigating menus 2157
 - Priority Editor 2166
 - re-entry 2163
- ## E
- Edge
 - node in Batch 1347
 - node in Modular Keyer 1636
 - edge code
 - See* keycode
 - edge-detection filters
 - Prewitt 1542
 - Sobel 1542
 - edit sync groups 992
 - EditDesk
 - loading clips 591
 - editing
 - See also* gestural editing, Batch timeline,
 - audio and video together, on desktop 940
 - commands on desktop 937
 - DLEDLs 370
 - EDLs 349, 361
 - four-point 1031
 - keycode in EDLs 367
 - on the desktop 928
 - replace 1029
 - ripple replace 1029
 - subtitle XML 469
 - three-point 1030
 - timecodes in EDLs 367
 - timewarps in EDLs 370
 - tracks in EDL 364
 - transitions in EDLs 365
 - wipes 1084
 - with the Batch timeline 928
 - with the Player timeline 928
 - editing audio
 - with editing commands on desktop 942

- Editing group 355
- Editing menu 33, 937
- EDL group 353
- EDL Save Options group 395
- EDL view 357
- EDLs
 - 2-3 Pulldown options 709
 - 2-3 Pulldown removal on
 - import 708
 - about 317
 - acts, creating 388
 - assembling 386
 - audio patching 362
 - audio, capturing 383
 - capturing clips 380
 - capturing media 377
 - closing 347
 - converting 339
 - creating 349, 360
 - editing 349, 361
 - exporting with 2-3 Pulldown
 - insertion 718
 - generating 399
 - importing 322, 335
 - importing files 385
 - importing media 377
 - keycode 367
 - loading file-based 340
 - non-native frame rates 337
 - output options 398
 - outputting 401
 - player 389
 - recapture, accessing 281
 - save options 395
 - saving 375
 - searching 346
 - supported formats 318
 - Tape List view 358
 - tape name, editing 361
 - timecode 367
 - timewarps, editing 370
 - tracks, editing 364
 - transitions, editing 365
 - Undo list 357
 - Varicam 338
 - view 357
 - viewing material 389
 - workflow 319
- EDM files
 - loading 344
- effects
 - AAF, supported 495
 - OMF, supported 510
 - supported in FCP XML 443
- Effects menu 33
- elements
 - adding to wipes 1095
 - copying in wipes 1098
 - deleting in wipes 1101
 - displaying information on
 - timeline 987
 - hiding in wipes 1099
 - naming 1096
 - naming on timeline 986
 - removing from timeline 988
 - searching on timeline 989
 - selecting in wipes 1096
 - selecting on timeline 984
 - swapping on Batch timeline 1012
- elements in timeline
 - trimming gesturally 1054
- ellipsoids in 3D Keyer
 - display options, setting 1684
 - scaling 1703
 - softness 1670
 - tolerance 1668
- emulsion, film in keycode 411
- end and start points
 - See* in and out points
- Engineering menu
 - setting options for HSDL I/O in 191
- enhanced EDLs
 - supported 319
- EQ
 - adjusting EQ settings 1232
 - bypassing 1237
 - controls, EQ Desk 1234
 - filter effects, about 1225
 - resetting 1235
 - soft effect 1216
- estimating archive size 615
- Events group 350

- example expression setups 2078
- Exclusion
 - Logical Operation 1434
- exiting
 - the application 923
- expanding
 - clips on the desktop 48
 - entries in clip libraries 573
 - image sequences in file browser 88
- explicit timewarps 1161
- export
 - managing in background 300
 - Resize 666
- Export
 - node in Batch 1347
- Export EDL menu 394
- Export Image menu 237
 - deleting files from system 268
- Export node
 - Resize 676
- Export Options group 238
- Export Video options 244
- exporting
 - AAF 483
 - audio 259
 - background 258
 - Cleaner XL 264
 - DPX images 249
 - export image options 237
 - FCP XML sequences 433
 - file formats supported 234
 - image files 245
 - images from Batch 1347
 - OMF files 502
 - RGBA images 248
 - video files 251
- expression functions
 - abs 2059
 - acos 2070
 - align 2051
 - asin 2070
 - atan 2071
 - atan2 2071
 - bell 2055
 - ceil 2067
 - cos 2068
 - cross 2072
 - degrees 2068
 - dot 2072
 - ease 2054
 - eval 2052
 - exp 2075
 - expm1 2075
 - floor 2067
 - fnoise 2064
 - frametoslip 2058
 - if 2053
 - length 2071
 - log 2073
 - log10 2074
 - log1p 2074
 - lookat 2052
 - max 2060
 - min 2060
 - mod 2061
 - noise 2063
 - noise3 2063
 - pingpong 2056
 - pow 2059
 - radians 2068
 - rand 2062
 - repeat 2057
 - repeatback 2057
 - round 2066
 - sign 2059
 - sin 2069
 - sqrt 2060
 - tan 2069
 - truerand 2062
 - trunc 2067
 - turbulence 2064
 - turbulence3 2065
- expressions
 - applying 2043
 - CascadeChannel keyword 2048
 - frame keyword 2042
 - functions 2051
 - linking channels 2045
 - modifying 2044
 - operators 2049
 - overview 2039
 - removing 2045

- SelectionOrder keyword 2047
- setups 2078
- user-defined functions 2076
- Extract Proxies
 - Format command 1445
- extracting
 - alpha channel 907
 - clips from an edit sequence 1032
- extrapolation
 - modes and curves 1983

F

- fade-ins and fade-outs
 - creating in timeline 1081
 - creating on the desktop 1072
- fades
 - creating audio 1209
- FBX
 - camera, in Action 2229
 - exporting 3D track results 2229
- fcof utility 912
- FCP XML
 - defined 431
 - exporting 433
 - importing 436
 - recapturing 442
 - relinking to media 439
 - supported effects 443
- field dominance
 - about 720
 - resolving conflicts with 721
- Field Merge
 - Format command 1445
 - node in Batch 1348
- fields
 - numeric 37
 - text 39
 - using the calculator 68
- file archives
 - creating 627
 - opening 633
 - pros and cons 604
- File Attributes group 209
- file browser 82
 - browsing proxies 87

- browsing titles 87
- CD-ROM drives, detecting 90
- collapsing image sequences 88
- creating directories 89
- deleting files 89
- expanding image sequences 88
- File list 85
- filtering file display 88
- floppy drives, detecting 90
- loading files 89
- refreshing the current view 89
- selecting files 89
- sorting files 87
- unselect all 89
- using bookmarks 86
- file formats
 - Advanced Authoring Format (AAF) 481
 - supported audio 195, 235
 - supported for import 194
 - supported on export 234
 - supported on Linux 196, 235
- File Operations group 201, 238
- files
 - list of in browser 85
 - reloading imported 284
- Fill command
 - in Paint 2453
- fill objects
 - drawing 2484
- film
 - emulsion, in keycode 411
 - gauges, supported for keycode 413
 - manufacturer, in keycode 411
- Film Compress
 - Format command 1445
- Film Expand
 - Format command 1445
- film gamma, modifying 760
- Film Gauge box 410
- film grain
 - See also* grain, ReGrain tool, DeGrain tool
 - about 773
 - adding 780
 - adding monochrome 784

- adding using custom/monochrome signature 786
- adding with a matte 792
- adjusting size 792
- analysing back clip 791
- defining area with crop box 794
- matching between clips 788
- removing 775, 777
- setups, saving and loading 795
- using preset signature 782
- Filter
 - node in Batch 1348
- Filter library 1537
- Filter, Processing command 1426
- filtering channels 1988
- filtering in file browser 88
- filters
 - See also* audio filters
 - applying to a clip 1536
 - blur filters in Keyer 1580
 - blurring 1542
 - Channel Editor 1991
 - custom 1538
 - in graphics 2494
 - in Paint 2437
 - inverting 1542
 - KeyIn filter 1583
 - library 1537
 - matrix 1538
 - opening the Filter menu 1535
 - Prewitt for edge detection 1542
 - procedural 1542
 - Sobel for edge-detection 1542
- Final Cut Pro XML. *See* FCP XML
- find-clip-of-frame utility. *See* fcof utility
- FireWire storage devices 629
- first active line, differences per
 - format 720
 - See also* field dominance
- fit-to-fill edits. *See* four-point edits
- fit-to-fill timewarps 1162
- flatten publish 292
- Flip node in Batch 1349
- Flipbook command 2414
- flipping
 - clips, in Processing commands 1432
- floating-point images
 - See also* OpenEXR
- floppy drives, detecting 90
- FLX files
 - loading 343
- FontMapping keyword 1925
- fonts
 - Adobe Type1, installing 874
 - in Text module 1951
 - installing 876, 921
 - nonstandard fonts, converting 875
 - supported fonts 873
 - TrueType, installing 876
- Force Render button
 - in Editing menu 966
- Format commands
 - accessing 1444
 - Burn In 1445
 - Change TC / KC / Rate 1445
 - Combine 1446
 - Deal 1446
 - Deinterlace 1445
 - Dominance 1445
 - Extract Proxies 1445
 - Field Merge 1445
 - Film Compress 1445
 - Film Expand 1445
 - Format menu 1445
 - Interlace 1445
 - Interleave 1446
 - preview results 1446
 - previewing results 1446
 - Regenerate Proxies 1445
 - Resize 1446
 - Separate 1445
- Format menu 33, 720
- formatting
 - See also* reformatting
 - dividing clips into smaller clips 1448
 - interleaving frames 1449
 - separating and combining channels 1446
- four-point edits 1031
- frame capture, from a VTR 151

- Frame Code Mode
 - changing 416, 421
- frame grab
 - See* capturing, single frame from VTR
- Frame Mode
 - Colour 1443
 - Colour Noise 1443
 - Noise 1443
 - PAL Bars 1443
 - SMPTE Bars 1443
- frame rate
 - adjusting audio 1252
 - converting EDLs 339
 - converting using a timewarp, in Batch timeline 1164
- FrameCut command 2514
- frames
 - black 880
 - copying, on desktop 958
 - finding clips for 912
 - inserting in clips, on desktop 951
 - invalid 880
 - matching with sources, on desktop 956
 - replacing, on desktop 954
 - reversing, on desktop 959
- Frames box 1429
- framestore
 - accessing remotely 523
 - freeing space in 305, 311, 313
 - performance testing 882
 - transferring clips 896
 - writing media 308
- framestore utilities. *See* utilities
- Framing Channels, in Channel Editor 1972
- Freehand button
 - in Warper 1888
- from_framestore utility 899
 - remote access 886
 - restrictions 898, 901
- full-screen Player
 - displaying 100
- functions
 - in expressions 2040

G

- gain
 - adjusting in Colour Corrector 1472
 - adjusting luminance of key in Keyer 1573
- Gain 1215
- gamma
 - adjusting in Colour Corrector 1471
 - adjusting in Colour Warper 1518
 - modifying in LUT Editor 758
 - resetting for all frames in Colour Warper 1522
 - resetting for current frame in Colour Warper 1522
- gang selection in Stabilizer 1790
- gaps 1041
 - creating effects 1145
- garbage masks
 - Action 3d geometry 2305
 - animating 1728
 - animating in Tracer 1752
 - animating its shape 1728
 - animating vertices on different channels 1730
 - animating with tracking 1735
 - defined 1708
 - determining use by plotting regions 1694
 - displaying 1716
 - drawing 1717
 - drawing order 1723
 - freehand drawing 1717
 - interlaced rendering 1740
 - loading and saving setups 1757
 - motion blur, applying 1738
 - moving 1724
 - node in Batch 1350
 - opacity 1712
 - order they are drawn 1723
 - ROI (Region of Interest), using with multiple garbage masks 1741
 - rotating 1724
 - scaling 1724
 - schematic, viewing 1722

- setups, preset 1759
- setups, raw 1760
- softness 1712
- softness, with advanced
 - gradient 1745
- straight edges 1726
- tangent handles, enabling
 - automatic 1716
- tangent handles, moving 1726
- tangent handles, selecting 1725
- Tracer 1743
- turning on and off 1712
- vertices, activating 1733
- vertices, adding 1733
- vertices, adjusting number drawn
 - freehand 1722
- vertices, deactivating 1733
- vertices, deleting 1735
- vertices, moving 1726
- vertices, removing 1733
- vertices, selecting 1725
- Gaussian blur
 - applying in Colour Warper 1508
 - applying to colour images in
 - Batch 1370
 - in Action 2146
- generating
 - EDLs 399
 - mattes in Keyer 1598
 - mattes in Modular Keyer 1635
- GeoCut command 2515
- geometry
 - importing in Action 2274
 - painting with 2422
 - particle parameters 2335
- gestural editing 1016, 1021, 1024
 - aligning 1022
 - cursors, on desktop 939
 - on desktop 939
 - on the timeline 1016
 - placing shots 1021
 - rippling timeline elements 1021
- Getting started 21
- Glow 1349
- glow effects
 - adding to clips 1778
- Glow node in Batch 1349
- Gmask
 - node in Batch 1350
- go to a frame
 - on desktop 51
- gradient
 - advanced, applying to garbage
 - masks 1743
 - animating in Paint 2505
- gradient mattes
 - in Paint, creating 2472
- grain
 - See also* film grain
 - adding to an image in Modular
 - Keyer 1640
 - removing from key in 3D
 - Keyer 1674
 - removing from key in Keyer 1580
 - removing from key in Master
 - Keyer 1555
 - removing from key in Modular
 - Keyer 1640
- graphics processing bit depth
 - setting 536
- graphics, in Paint
 - adding 2476
 - anamorphic geometry 2492
 - animating 2502
 - animating gradients 2505
 - Auto Point 2499
 - bezier curves 2500
 - blending 2519
 - brush tools 2477
 - buffer, recalling from 2507
 - buffer, storing to 2507
 - changing order for objects 2489
 - deleting objects 2488
 - drawing objects 2477
 - drop shadows 2520
 - editing objects 2488, 2497
 - embossing 2517
 - extruding 2518
 - fill tool 2484
 - gradients 2494, 2505
 - hiding objects 2489
 - hiding vertices 2491

- increasing speed 2491
- menu 2475
- moving objects 2498
- object attributes 2492
- outlining objects 2492, 2494
- resizing objects 2497–2498
- resolution, setting for objects 2490
- rotating objects 2497–2498
- rubber banding 2483
- saving 2507
- selecting objects 2486
- shape animation 2503
- shapes 2498
- solid and soft edge objects 2492, 2494
- tacking 2508
- text object 2485
- transforming objects 2497
- using AutoPaint with 2501
- wireframe 2490, 2492
- wireframe options 2490
- grids and guides 116
 - accessing from all modules 117
 - aspect ratio guides 121
 - centre point 128
 - custom safe title and safe action 124
 - default safe action 124
 - default safe title 124
 - displaying the proper aspect ratio 129
 - frame border 129
 - free guides 120
 - grids 126
 - in Paint 2410
 - loading setups 119
 - safe areas 124
 - saving setups 118
 - selecting presets 118
 - working area guides 119
- grouping nodes 1305
 - display settings 1308
 - editing 1307
- guides. *See* grids and guides

H

- HardLight
 - Logical Operation 1434
- HDCAM archives, creating 623
- HDCAM SR device, archiving 619
- header information slate, about 620
- heads and tails
 - displaying in timeline 1049
 - offsets, in timeline 1050
- Hermite interpolation, about 1981
- hiding strokes 2379
- hiding tangents, in Channel Editor 1989
- High Cut filter 1227
- High Shelf filter 1226
- high-contrast
 - mattes, generating 1439
- highlights
 - colour correcting in Colour Corrector 1467
 - matching in Colour Warper 1524
 - modifying in Colour Warper 1510
 - removing colour in Colour Warper 1511
- histogram
 - 2D histogram in Batch 1332
 - in Keyer 1569
 - luma, viewing in Colour Warper 1493
 - using in 12-bit mode in Colour Corrector 1475
 - See also* 3D histogram
- history
 - committing 312
- Hot Key Editor. *See* hot keys
- hot keys
 - catalogues 866
 - cloning a button, field or function 870
 - creating 870
 - determining for buttons 865
 - displaying errors 865
 - editing 868
 - functional 863
 - hiding panel 870
 - Hot Key Editor 865

- keyboard type 867
 - keystroke conventions 864
 - local, shared, global 864
 - managing 870
- HSDL I/O
 - hardware setup 189
 - setting Engineering menu
 - options 191
 - software setup 189
 - workflow 188
- HTML Help
 - accessing 834
- HTML TOC, viewing archives 643
- hue
 - adjusting in Colour Corrector 1468
 - cube in Colour Warper 1508
 - shifting in Keyer 1588
 - shifts, performing in Colour Warper 1526
- I**
- IEEE 1394 devices. *See* FireWire storage devices
- Image Export controls, in Batch 1347
- image files
 - deleting from file system 232, 268
 - exporting 245
 - importing 210
 - substituting for video sources 286
- Image Import controls, in Batch 1350
- image window
 - displaying the frame border 129
 - displaying the proper aspect ratio 129
 - monitoring dominant fields 136
 - monitoring full frames 136
 - monitoring RGB channels 135
 - multiple views 136
 - panning and zooming 112
 - playback controls 111
 - playing clips in 111
 - reference area 131
 - setting up grids and guides 116
- images
 - applying colours and filters 2451
 - applying random paint strokes 2460
 - Batch, importing 1285
- imbalances
 - correcting in Colour Warper 1510
- imcopy utility 901
- iminfo utility 911
- implicit timewarps 1161
- Import Image menu 201
 - deleting files from system 232
- Import node
 - in Batch 1350
 - Resize 669
- importing
 - 3ds Max models 2274
 - Advanced Authoring Format 484
 - aspect ratio, forcing on import 698
 - audio 229
 - background 227
 - Batch, clips 1285
 - DPX images 213
 - EDLs 322, 335
 - EDLs, non-native frame rates 337
 - FCP XML 436
 - file formats supported 194
 - files using EDLs 385
 - image files 210
 - image import options 201
 - managing in background 300
 - OMF files 500
 - OpenEXR images 218
 - Photoshop files 222
 - Resize 666
 - RGBA images 220
 - subtitle XML 466
 - Varicam with EDLs 338
 - video files 224
- Impressionist medium 2443
- in and out points 1003
 - four-point edits 1031
 - three-point edits 1030
- Information box
 - in clip libraries 577
- Information Table, in Channel Editor
 - accessing 1965

- init.cfg file
 - See software initialization configuration file
 - Input Clip menu
 - accessing from desktop 146
 - options, described 147
 - input strip
 - adjust pan settings 1223
 - assign to output strip 1223
 - audio 1205
 - gain adjust 1221
 - muting 1224
 - phase shifting 1225
 - soloing 1224
 - inputting
 - clips, using a VTR 146
 - clips, using HSDL device 189
 - YUV material, using a VTR 180
 - Insert button
 - in Editing menu 951
 - insert edits
 - gestural, on desktop 939
 - inserting clips
 - on desktop, with audio 953
 - on desktop, with Insert command 951
 - inserting clips in edit sequence 1025
 - instancing
 - DVE Layer Objects 2161
 - integrity check 879
 - integrity checking tool 917
 - Interlace
 - Format command 1445
 - node in Batch 1346
 - interlaced video
 - about 719
 - adding value of blending between fields 727
 - garbage masks, rendering 1740
 - working with mixed-resolution projects 721
 - Interleave
 - Format command 1446
 - interleaving
 - clips, using Format commands 1449
 - intermediates
 - deleting from clip history 815
 - removing by compacting clips 313
 - interpolation
 - expressions 2043
 - modes and curves 1980–1981
 - Invalid Frames error message 880
 - inverting mattes 2470
 - IRIX, compatibility 16
- J**
- jitter
 - in Stabilizer, removing 1796
 - removing from animation curve 2021
 - Jitter brush attribute 2384, 2431
 - join
 - See also splice
- K**
- Keep Cut On button
 - in Paint 2513
 - kerning text 1931
 - keyboard
 - using in Text 1925
 - keycode
 - about 403
 - assigning manually 423
 - burning in 428
 - calculator 410
 - changing 415, 419
 - copying 421
 - displaying 405
 - displaying in clip information overlay 408
 - displaying in List view 409
 - displaying in Player 407
 - displaying in timeline 408
 - editing in EDLs 367
 - film gauge support 413
 - removing conflicts 425
 - syntax 411
 - Keyer 1545
 - See also keying, mattes, Master Keyer

- accessing from Action 2150
- blur filters 1580
- clips, loading 1546
- colour curves, editing 1593
- Colour Suppression tools 1584
- colour values, plotting 1568
- Degrain controls 1580
- garbage masks, using with
 - defined 1708
- histogram 1569
- keyed area, limiting 1596
- KeyIn filter 1583
- luminance curve, adjusting 1573
- Matte Edge controls 1576
- node in Batch 1351
- node in Batch, example 1303
- processing options 1600
- solid colour background, using 1595
- keyframes
 - adding to animation curve 2003
 - adding to speed curve 2026
 - averaging 2021
 - copying 2002
 - defined 1964
 - deleting 2004
 - moving 2005
 - selecting 2007
 - setting 1972
 - setting in Warper 1902
 - setting manually 1977
 - snapping to frames 2006
- keyframing
 - garbage masks, setting options 1730
- keying
 - See also* 3D Keyer, Keyer, Modular Keyer, mattes, nodes, RGB Viewer, 3D histogram in 3D Keyer, grain, tolerance, softness
 - additive key, creating in Keyer 1600
 - additive key, creating in Modular Keyer 1645
 - animating in 3D Keyer 1701
 - animating in Keyer 1594
 - animating in Modular Keyer 1658
 - blending front and back clips in Keyer 1590
 - blending front and back clips in Master Keyer 1553
 - blending front and back clips in Modular Keyer 1652
 - blurring colour images in Modular Keyer 1631
 - blurring edges of matte in Modular Keyer 1637
 - colour correcting front clip in Keyer 1593
 - colour correcting result clip in Keyer 1592
 - colour models, selecting in Keyer 1563
 - colour spill, suppressing in Keyer 1584
 - colour spill, suppressing in Master Keyer 1551
 - custom colours, extracting in Keyer 1560
 - edges of key, adjusting in Keyer 1548
 - edges of key, adjusting in Modular Keyer 1636
 - grey areas, removing from key in Keyer 1573
 - grey areas, removing from mattes in 3D Keyer 1677
 - grey areas, removing from mattes in Master Keyer 1558
 - hue, shifting in Keyer 1588
 - in Action 2150
 - luminance, adjusting in mattes in Modular Keyer 1632
 - luminance, creating keys in Keyer 1561
 - negatives, generating in Modular Keyer 1642
 - primary colours, extracting in Keyer 1560
 - softness range, setting in 3D Keyer 1670
 - softness range, setting in Keyer 1565
 - softness, adjusting in 3D Keyer 1703

- softness, improving shadows and
transparencies in 3D
Keyer 1676
- tolerance range, setting in 3D
Keyer 1666
- tolerance range, setting in
Keyer 1567
- transparencies, adjusting with patches
in 3D Keyer 1705
- workflow in 3D Keyer 1662
- workflow in Master Keyer 1548
- keywords
 - FontMapping 1925
 - Video 145
 - VTR 145
- Kill process command 923

L

- Lanczos filter 684
- layer order, of garbage masks 1712
- layers
 - collapsing on timeline 1039
 - creating on timeline 1037
 - gaps 1041
 - muting on timeline 1039
- length. *See* duration
- Lens Distort
 - node in Batch 1352
- letterbox formats
 - Burn In Letterbox node 1341
- letterbox formatting
 - See* outputting clips, with letterbox
overlay
- library
 - Batch, loading clips 1285
- Library menu 33
- Library node
 - copying clips to desktop from 1279
 - in Batch 1356
- Library Operations options 210
- Library View Mode box 560
- lift
 - adjusting luminance of key 1573
- lifting
 - clips from an edit sequence 1032

- light source
 - particle generation, in Action 2325
- lights
 - adding 2308
 - flipping normals 2318
 - selective lighting 2311
 - specular highlights 2314
- limiting strokes 2380
- Linear extrapolation, about 1983
- Linear interpolation, about 1981
- Link button, in Channel Editor 2035
- Linked mode archiving 629
- linking
 - nodes in Batch automatically 1295
 - transitions and cuts in
timeline 1052
- Linux
 - compatibility 16
 - supported codecs 196, 235
- list utility 894
- List view
 - displaying keycode and
timecode 409
- List View mode 571
- List View mode, in clip libraries 575
- list_framestore utility 895
- live video signal, inputting and
outputting 163
- Load EDL menu 334
- loading
 - Batch setups 1266
 - clips 591
 - clips in Player 94
 - different projects 551
 - different users 551
 - file-based EDLs 340
 - in file browser 89
 - on desktop reels 49
 - setups and preferences 803
 - Text files 1919
- Lock button
 - on desktop 56
- lock files, troubleshooting 600
- locking
 - Action clips 2142
 - clips duration 2408

- clips to prevent changes 56
- reels on the desktop 55
- sources 2381
- text layers 1930
- timeline elements 1185
- log files 882
- Logic Op
 - node in Modular Keyer 1641
- Logic Ops, Processing command 1426
- Logical Operation
 - Add 1433
 - And 1433
 - AndInv 1434
 - AndRev 1434
 - Difference 1434
 - Exclusion 1434
 - HardLight 1434
 - Max/Lighten 1434
 - Min/Darken 1434
 - Multiply 1434
 - Nand 1434
 - Nor 1435
 - Or 1435
 - OrInv 1435
 - OrRev 1435
 - Overlay 1435
 - Screen 1435
 - SoftLight 1435
 - Subtract 1436
 - Xnor 1436
 - Xor 1436
- logical operations
 - in Processing menu 1433
- Logical Operations
 - in Batch 1356
- logos
 - loading into Text module 1934
- logs
 - Batch, in a text file 1279
 - Batch, in a webpage 1279
- looping playback, in Player 99
- Lost and Found library 880
- Low Cut filter 1231
- Low Shelf filter 1230
- luma
 - adjusting 1518
 - adjusting after colour
 - correction 1528
 - adjusting ranges 1508
 - calculated by two source clips in
 - Modular Keyer 1641
 - defining ranges in Colour
 - Corrector 1478
 - modifying with Processing
 - commands 1441
 - resetting curves for all frames 1522
 - resetting curves for current
 - frame 1522
 - viewing with 2D luma
 - histogram 1493
- luminance
 - adjusting in mattes in Keyer 1569
 - adjusting in mattes in Modular
 - Keyer 1632
 - creating keys according to in
 - Keyer 1568
 - curves, adjusting in Modular
 - Keyer 1643
 - curves, choosing mattes for
 - composites in Keyer 1600
 - mattes, values for 2472
- Luminance Key
 - node in Batch 1357
 - node in Modular Keyer 1642
- LUT Editor
 - 1D LUTs, creating 749
 - 3D LUTs, processing clips with 742
 - accessing from Batch 748
 - accessing from the desktop 745
 - advanced editing curves 762
 - exporting LUTs 768
 - film gamma, modifying 760
 - gamma correction 758
 - importing LUTs 752
 - loading setups 767
 - node in Batch 1357
 - node in Modular Keyer 1642
 - node, accessing 748
 - patches, sampling 765
 - saving setups 766
 - selecting a basic LUT type 752

- setting the output bit depth in
 - Batch 752
- softclip, setting 761
- viewing reference clips 750
- viewing reference clips in Batch 750

LUTs

- 3D LUT format 735
- See also* 3D LUTs, 1D LUTs
- advanced editing using RGB
 - curves 762
- applying on export 744
- applying on import 744
- Batch, applying to clips 1288
- exporting 768
- highlights, setting 757
- in Keyer 1573
- reference black, setting 755
- reference white, setting 755
- sample LUTs, applying 744
- shadows, setting 757
- softening the shoulder of the gamma
 - conversion curve 761

M

- magnet
 - Magnet Curve Editor 2194
- Magnet button
 - in Warper 1889
- Main menu 32
- manufacturer, film in keycode 411
- Map Source box 1160
- masks
 - See also* garbage masks
 - changing shape 1088
 - creating in the Wipe Editor 1086
- Master Keyer
 - See also* mattes, keying, Keyer, patches
 - bypassing in the Modular
 - Keyer 1631
 - Degrain tools 1555
 - node in Batch 1358
 - node in Modular Keyer 1631
 - steps for creating and refining a
 - key 1548

- MasterK node 1358
 - See also* Master Keyer, mattes, keying,
 - Keyer, patches 1631
- Match Source button
 - in Editing menu 956
- matching
 - cancelling operation in Colour
 - Warper 1525
 - clearing operation in Colour
 - Warper 1525
 - colours in Colour Corrector 1465
 - colours in Colour Warper 1523
 - shadows, highlights, saturation in
 - Colour Warper 1524
- matching clips 1013
- matrix filters 1538
- matte
 - garbage masks, removing parts 1708
 - outputting from Batch setup 1402
- matte containers
 - creating 1123
- Matte Curves
 - node in Batch 1359
 - node in Modular Keyer 1632
- Matte Invert Lock button 2470
- matte processing
 - in Action 2144
- Matte Transparency button 2469
- mattes
 - adding to blend nodes 1651
 - Auto Matte in Paint 2472
 - changing colour 2468
 - creating 2470
 - creating gradients 2472
 - defined in Keyer 1545
 - deleting from animation curve in
 - Colour Warper 1509
 - deleting in Colour Warper 1509
 - enabling 2467
 - filters, applying Erode, Shrink, and
 - Blur 1347
 - generating for selective colour
 - correction in Colour
 - Warper 1503
 - generating for text in Soft Text 1139
 - generating in Keyer 1598

- generating in Master Keyer 1549
- generating in Modular Keyer 1635
- generating with Processing
 - commands 1437
- high-contrast, generating 1439
- inverting 2470
- inverting in Colour Warper 1498
- limiting strokes with matte 2389
- limiting strokes with source
 - matte 2380
- loading 2470
- luminance values 2472
- resetting, in Paint 2471
- saving 2470
- transparency 2469
- using 2467
- viewing 2468
- Max/Lighten
 - Logical Operation 1434
- MBlend
 - node in Modular Keyer 1649
- MBlend node
 - adding a matte 1651
- media
 - See also* special effects media
 - adding in Action 2137
 - blurring, in Action 2146
 - capturing using EDLs 377
 - changing, in Action 2141
 - copying, in Action 2142
 - cropping, in Action 2147
 - defined 292
 - deleting from file system 232, 268
 - deleting, in Action 2143
 - dividing, in Action 2149
 - exporting to Cleaner XL 264
 - grouping, in Action 2207
 - importing using EDLs 377
 - loading, in Action 2134
 - recapturing 280
 - recognizing soft-imported 200
 - relinking 269
 - relinking to clips 289
 - slipping in Action 2149
 - unlinking 269
 - unlinking from clips 270
 - writing to the framestore 308
- menu
 - customizing 832
- merging
 - timeline layers 1183
- merging fields 727
- meshes
 - copying and pasting 1895
 - for morphing 1899
 - in Warper 1880
- message bar 41
- message history 41
 - accessing 835
- messages
 - log file 884
- metadata
 - AAF, supported 490
 - contents of clip 556
- Mid Notch filter 1229
- Mid Presence filter 1228
- midtone
 - colour correcting in Colour
 - Corrector 1467
 - defining range in Colour
 - Warper 1513
 - removing colour in Colour
 - Warper 1511
- Min/Darken
 - Logical Operation 1434
- missing media in Batch 1332
- missing media, defining output 1290
- Mix command 1075
- Mix Range field 1154
- mixed resolution clips
 - archiving 608
- mixing clips
 - on the desktop 1075
- Modular Keyer
 - See also* 3D Keyer, processing pipeline, Tracer, nodes, keying, blend nodes, mattes
 - accessing 1604
 - accessing from Action 2152
 - accessing menus from 1607
 - colours, comparing 1626
 - context points 1624

- Current Result proxy 1609
- images, changing in image
 - window 1608
- keyed area, limiting 1627
- layers, selecting 1652
- luminance curve, adjusting 1643
- Matte controls 1636
- node bars 1614
- node in Batch 1359
- nodes, saving 1629
- pipeline, default 1606
- processing 1646
- setups, backing up 1628
- setups, saving 1628
- Modulation 1241
- Modulation Send 1214
- modules
 - See also* nodes, Colour Corrector, Action, Keyer, Paint, Text, Stabilizer
 - accessing from Batch 1272
 - loading same clips 110
 - processing 307
- monitoring
 - video, during clip I/O 161
- monochrome
 - clips, generating using Format commands 1447
 - clips, generating using Processing commands 1440
- Monochrome
 - node in Batch 1360
 - node in Modular Keyer 1642
- Monochrome, Processing
 - command 1427
- Morph button
 - in Warper 1878, 1899
- morphing
 - between live-action clips 1904
 - between still clips 1903
 - meshes for 1899
 - one image into another 1899
 - spline-based versus
 - mesh-based 1825
 - with Distort 1823
 - with the Warper 1877
- Motion Analysis node in Batch 1360
- motion blur
 - Average Over field 1429
 - examples 1429
 - Frames box 1429
 - garbage masks, applying 1738
 - garbage masks, applying to
 - stationary 1740
 - in Action 2237
 - in Batch 1362
 - simulating with Processing
 - commands 1428
 - using external motion data in
 - Batch 1176
 - Weighted and Uniform box 1429
- Motion Blur
 - node in Batch 1362
- motion estimation 1176
- Motion Analysis node 1360
- Motion Blur node 1362
- speed and timing curves,
 - modifying 1363
- using Batch nodes 1174
- motion paths
 - controls points 2027
 - creating motion path
 - animation 2023
 - creating text 1944
 - modifying 2026
- mouse
 - preferences 830
 - using in Paint 2408
- Move button
 - in Warper 1885
- moving
 - clips 896, 899, 901
 - nodes in Batch 1301
- moving axes, in Action 2172
- multiple clips
 - selecting in clip libraries 580
- multiple resolutions
 - See* mixed resolutions
- multiple views in modules 136
- multiple-resolution clips
 - editing on desktop 936

- Multiply
 - Logical Operation 1434
- muting
 - audio 1208
 - input strips 1224
- MUX node in Batch 1364

- N**
- naming
 - Batch, grouped nodes 1308
 - Batch, nodes and clips 1299
 - clips on the desktop 58
 - desktops 59
 - entries in clip libraries 588
 - projects 526
 - reels on the desktop 59
 - tapes in clip libraries 578
- Nand
 - Logical Operation 1434
- Negate option, in Channel Editor 2020
- Negative
 - clips, creating with Processing
 - commands 1440
 - node in Modular Keyer 1642
 - Processing command 1427
- Negative node in Batch 1364
- network library 595
 - accessing local and remote
 - libraries 593
 - auto-connecting clip libraries 597
 - entries 596
 - refreshing 595
 - selecting local and remote
 - libraries 597
 - structure 596
- node bars
 - in Batch 1291
- Node bin
 - in Action 2097
- nodes
 - 2D Histogram in Modular
 - Keyer 1630
 - See also* processing pipeline, Modular
 - Keyer, Batch
 - adding in Batch 1291
 - adding to pipeline 1614
 - bars of, in Batch 1266
 - bypassing in Batch 1303
 - cache tab 1293
 - cache tab, states 1320
 - caching 1319
 - CBlend in Modular Keyer 1648
 - clips and nodes, connecting 1292
 - Colour Correct in Modular
 - Keyer 1633
 - Colour Curves in Modular
 - Keyer 1633
 - Colour Warper in Modular
 - Keyer 1635
 - copying in Batch 1301, 1616
 - custom 1309
 - defined 1260
 - Degrain in Modular Keyer 1640
 - deleting 1617
 - deleting in Batch 1302
 - Desk in Modular Keyer 1621
 - Difference Matte in Modular
 - Keyer 1635
 - Edge in Modular Keyer 1636
 - linking, automatic 1295
 - location on pipeline 1605
 - Logic Op in Modular Keyer 1641
 - Luminance Key in Modular
 - Keyer 1642
 - LUT Editor in Modular Keyer 1642
 - MasterK in Modular Keyer 1631
 - Matte Curves in Modular
 - Keyer 1632
 - MBlend in Modular Keyer 1649
 - Monochrome in Modular
 - Keyer 1642
 - moving in Batch 1301
 - moving on pipeline 1616
 - multiple input 1611
 - naming 1620
 - Negative in Modular Keyer 1642
 - placing on pipeline 1658
 - Regrain in Modular Keyer 1640
 - Result in Batch 1606
 - Result in Modular Keyer 1643
 - RGB Blur in Modular Keyer 1631

- saving in Modular Keyer 1629
 - selecting in Batch 1300
 - selecting on pipeline 1613
 - self-defined, creating 1309
 - single input 1610
 - tabs described 1292
 - unbypass 1280
 - updating in Modular Keyer 1619
 - nodes, in Batch 1349
 - 2D Histogram 1332
 - 3D Keyer node 1332
 - about 1330
 - Action 1333
 - Add Pulldown 1335
 - Auto Matte 1336
 - Auto Stabilize 1336
 - Average node 1339
 - BFX Output 1339
 - Burn In Letterbox 1341
 - Burn In Timecode 1342
 - Colour Correct 1342
 - Colour Curves 1342
 - Colour Warper 1344
 - Coloured Frame 1343
 - Combine 1344
 - Compound 1345
 - Deal 1345
 - Degrain 1345
 - DeInterlace 1346
 - Difference Matte 1346
 - Distort 1347
 - Edge 1347
 - Export 1347
 - Field Merge 1348
 - Filter 1348
 - Flip 1349
 - GMask 1350
 - Import 1350
 - Interlace 1346
 - Keyer in Batch 1351
 - Lens Distort 1352
 - Library 1356
 - Logic Op node 1356
 - Luminance Key 1357
 - LUT Editor 1357
 - Master Keyer 1358
 - Matte Curves 1359
 - menu, accessing 1331
 - Modular Keyer node 1359
 - Monochrome 1360
 - Motion Analysis 1360
 - Motion Blur 1362
 - MUX 1364
 - Negative 1364
 - Optics 1365
 - Output 1365
 - Paint 1368
 - Posterize 1369
 - Quick Composite 1369
 - Regrain 1345
 - Remove Pulldown 1335
 - Resize 1369
 - RGB Blur 1370
 - Spark 1372
 - Text 1373
 - Noise
 - clips, creating with Processing
 - commands 1442
 - Frame Mode 1443
 - removing from clips using Processing
 - commands 1431
 - Noise Gate 1218
 - Nor
 - Logical Operation 1435
 - normal archives, about 634
 - notepad, *See* notes
 - Notes
 - adding 1271
 - node in Battch 1365
 - numeric fields 37
 - using the calculator 69
- O**
- offline edit
 - AAF, transferring with 481
 - offsets
 - adjusting in Colour Corrector 1472
 - animating in Stabilizer 1805
 - head and tail, in Batch
 - timeline 1049
 - head and tail, in timeline 1050

- offsetting
 - cloned sources 2394
 - sources in Batch Paint 2397
 - offsetting clips
 - Timing View 1277
 - OMF
 - about 499
 - exporting 502
 - importing 500
 - supported effects 510
 - supported transitions 505
 - online documentation 5
 - opacity
 - garbage masks, controlling 1712
 - Opacity brush attribute 2382, 2428
 - Open Media Format
 - See OMF
 - OpenEXR
 - accessing LUT Editor 770
 - adding clips in Batch 1287
 - adding clips to Batch processing tree 1332
 - importing 218
 - in Action 2094
 - LUT Editor node, converting images 1358
 - supported editing operations 937
 - using clips for motion estimation in Batch 1176
 - Operations group 323
 - Optics
 - node in Batch 1365
 - Optics module 1778
 - Or
 - Logical Operation 1435
 - order
 - Batch, setting processing priority 1325
 - OrInv
 - Logical Operation 1435
 - OrRev
 - Logical Operation 1435
 - out points. *See* in and out points
 - Output
 - node in Batch 1365
 - output channels
 - activating on timeline 979
 - Output Clip menu
 - accessing from clip library 153
 - accessing from EditDesk 153
 - options described 154
 - Output node
 - Resize 674
 - Output Options group 398
 - output strips
 - audio 1246
 - gain 1247
 - limiter 1248
 - outputting
 - clips in assemble mode 161
 - clips to a VTR 153
 - clips with letterbox overlay 160
 - clips, using HSDL device 191
 - missing media in Batch 1332
 - multiple clips to VTR 159
 - proxies in Action 2116
 - single clips to VTR 157
 - YUV material, using a VTR 180
 - outputting EDLs 401
 - overlay
 - in Batch Paint 2402
 - Overlay
 - Logical Operation 1435
 - oversampling, in Stabilizer 1815
 - overwrite editing
 - clips in edit sequence 1027
- ## P
- Paint 2405
 - See also* graphics, in Paint
 - animating Paint strokes 2464
 - Auto Matte command 2472
 - AutoPaint 2457
 - brush attributes 2428
 - brush setups 2526
 - colour correcting the clips 2534
 - colour palette 2412
 - copying graphics 2488
 - creating a matte 2470
 - custom brushes 2527

- filling an area with colour 2453
- filters 2437
- Flipbook 2414
- full-resolution film images 2415
- library 2524
- loading a matte 2470
- media. *See* special effects media, brush attribute
- node 2374
- recording brush strokes 2462
- reference images 2433
- revealing the back image 2444
- Roll command 2421
- saving a matte 2470
- saving and restoring images 2416
- selecting brushes 2420
- selecting colours 2411
- setups 2524
- tracking with AutoPaint 2463
- using a matte 2467
- Wipe command 2451, 2458
- Paint node in Batch
 - See also* Batch Paint
- painting
 - circles with geometry 2424
 - circles with object tool 2481
 - ellipses 2480
 - full-resolution film images 2415
 - in Batch Paint 2388
 - limiting strokes with matte 2389
 - limiting strokes with source matte 2380
 - lines 2422, 2478
 - on the canvas 2419
 - rectangles 2424, 2478
 - squares 2478
 - triangles 2479
 - triangles with geometry 2425
 - with geometry 2422
- PAL Bars
 - creating with Processing commands 1442
 - Frame Mode 1443
- pan and scan 688
- panning
 - the image window 112
- Parametric Mid filter
 - using 1234
- parent
 - node to another 1292
- parent mode
 - in Schematic view 1102
 - schematic, in Action 2110
- particles
 - bouncers 2362
 - Channel Editor 2336
 - combining streams 2366
 - custom 2336
 - exploding objects 2340
 - functions, using in Action 2354
 - generating streams, in Action 2324
 - geometry properties 2335
 - manipulators, in Action 2343
 - rendering streams 2332
 - setup samples 2368
 - stream properties 2329
 - textures, applying 2339
- Paste button
 - in Warper 1895
- patch panel 1001
- patches
 - animating in 3D Keyer 1702
 - defined in 3D Keyer 1678
 - display options, setting in 3D Keyer 1685
 - patch edges, softening in 3D Keyer 1678
 - sampling in 3D Keyer 1678
 - sampling in LUT Editor 765
 - selecting in 3D Keyer 1687
 - setting the softness of 1680
 - using to remove greys in Master Keyer 1558
- patching
 - channels 997
 - on the timeline 998
 - with the patch panel 1001
- pathname 800
- PDF documentation 5
 - accessing 834
- pen and tablet 34

- phase shifting
 - input strips 1225
- Photoshop files
 - importing in Action 2130
 - importing, overview 222
- pickers
 - advanced gradient, using with 1747
 - animating 1753
 - assigning to vertices 1749
 - defined 1709, 1746
 - interpolation between
 - keyframes 1755
 - selecting 1725
- picking colours 71
- ping pong option, in the Player 99
- pipeline. *See* processing pipeline
- pipes
 - bypassing 1657
 - in blend nodes 1647
- planes
 - in Action 2173
- play once option, in the Player 99
- playback controls
 - in modules 112
- Player 94
 - 2-3 Pulldown, monitoring 715
 - accessing from modules 114
 - aspect ratio, displaying 129
 - changing playback frame rate 104
 - clips, loading 94
 - clips, playing 94
 - display options, setting 99
 - displaying timecode and
 - keycode 407
 - dual timecodes, monitoring 715
 - EDLs 389
 - full-screen, displaying 100
 - grids and guides, setting up 116
 - loading entire reel 95
 - looping playback 99
 - maintaining audio and video
 - sync 105
 - ping pong option 99
 - play once option 99
 - playback controls 96–97
 - playback options 99
 - Playback Range box 100
 - playing clips from memory 101
 - scan mode options 105
 - scrubbing audio 1203
 - selecting playback scan mode 104
 - setting a playback range 100
 - timeline, creating dissolves 1078
- Player timeline
 - editing 928
- playing
 - clips on the desktop 45
 - on desktop reels 49
 - timelines 975
- plotting
 - colours in Colour Warper 1501
- plug-ins (Sparks)
 - developing 1960
 - replacing currently loaded 1958
 - using as a module 1959
 - using on the desktop 1959
- pointer
 - preferences 830
- PolyCut button
 - in Paint 2514
- polygons, drawing 2482
- portable archives. *See* FireWire storage devices
- Posterise, Processing command 1427
- posterising
 - with Processing commands 1441
- Posterize
 - node in Batch 1369
- posttrail 1159
- preferences
 - accessing 828
 - audio 853
 - Batch 1278
 - broadcast monitor 830
 - Channel Editor filter 1991
 - copying 546
 - custom menus 832
 - defined 800
 - desktop 848
 - documentation 834
 - for restoring archives 650
 - general 836

- loading 803
- loading factory default 805
- pointer 830
- Preview 829
- project management 828
- removing from directories 804
- saving 803
- saving as default 805
- sharing 546
- storage 860
- timeline 841
- tooltips 835
- user interface 831
- Pressure brush attribute 2383, 2430
 - mode 2435
- Pretracking
 - in Stabilizer 1815
- pretrail 1159
- preview
 - Format command results 1446
 - Format commands 1446
 - Processing command results 1427
 - Processing commands 1427
 - shots, placement 1024
- Preview
 - preferences 829
- Preview command
 - in Paint 2416
- previewing
 - A/V tools results 109
 - Batch 1313
 - shots on timeline 1024
- Prewitt filter for edge detection 1542
- priority
 - processing order in Batch 1325
- Priority Editor
 - in Action 2204
- priority, garbage masks
 - drawing order 1723
 - order 1712
- procedural filters 1542
- process indicator
 - Batch Queue Manager 1324
- Process tree menu
 - described 1299
- process trees
 - assembling in Batch 1283
 - branch 1300
 - connecting nodes 1293
 - defined 1261
 - definition of branches 1300
 - moving nodes 1301
 - multiple node connections 1296
 - processing 1322
- processes, stopping 923
- processing
 - about 291
 - clips and proxies 305
 - in Colour Corrector 1481
 - in Keyer 1599
 - in Modular Keyer 1646
 - in modules 307
 - in timeline 302
 - selected frames of timeline 1187
 - status of timeline elements 1180
- Processing commands
 - accessing 1426
 - Auto Matte 1426
 - Average 1426
 - Batch 1426
 - Colour Correct 1427
 - Coloured Frame 1427
 - Compound 1426
 - DeGrain 1427
 - Difference 1426
 - Filter 1426
 - Logic Ops 1426
 - Monochrome 1427
 - Negative 1427
 - Posterise 1427
 - preview results 1427
 - previewing results 1427
 - ReGrain 1427
- Processing group 206
- Processing menu 33
- processing pipeline
 - See also* blend nodes, Modular Keyer, nodes
 - branches 1606
 - clips, adding 1621
 - context points, setting 1624

- MasterK node, bypassing 1631
 - nodes, adding 1614
 - nodes, location on pipeline 1605
 - nodes, moving 1616
 - nodes, placing on pipeline 1658
 - nodes, selecting on pipeline 1613
 - schematic, panning 1626
 - Project box
 - in file browser 85
 - project configuration file. *See* configuration file
 - Project Management
 - preferences 828
 - projector
 - blend modes, in Action 2292
 - in Action 2289
 - projects
 - auto-connecting clip libraries 545
 - backward compatibility 13
 - clip libraries, sharing 545
 - configuration template,
 - selecting 537
 - creating 526
 - deleting 539
 - deleting all clips 539
 - deleting all setups 539
 - entering a description 526
 - graphics processing bit depth,
 - setting 536
 - home directories, sharing 529
 - loading on start-up 525
 - modifying 538
 - naming 526
 - proxy management options 532
 - scan mode, changing default 721
 - setups, copying 528
 - setups, sharing 528
 - sharing between products 14
 - switching 551
 - upgrade compatibility 11
 - working with proxies 541
 - Proportional button
 - in Warper 1882
 - proxies
 - about 199
 - displaying keycode 405
 - extracting 544
 - generating during clip input 153
 - management options for
 - projects 532
 - mode, in clip libraries 568
 - outputting in Action 2116
 - playback 542
 - processing 305, 543
 - project settings 532
 - proxy mode, in Batch 1286
 - quality box 148
 - regenerating 543
 - using in Action 543
 - using in Batch 543
 - working with 541
 - Proxies group 243
 - Publish tool 294
 - using 297
 - Publish tool, using 297
 - publishing
 - about 291
 - background task 298
 - managing in background 300
 - types 292
 - publishTool utility 913
 - pulldown
 - See* 2-3 Pulldown
 - partitions
 - 12-bit 898, 900
- ## Q
- Quality group 240
 - Queue Manager
 - Batch, accessing in 1323
 - controls, described 1324
 - Export node 1347
 - name of result 1325
 - scripts in Batch 1325
 - timecode, setting output 1324
 - Quick Composite
 - module 1777
 - node in Batch 1369
 - QuickTime
 - supported codecs 196, 235
 - quitting the application 923

R

- Rate brush attribute 2382, 2429
- re-entry
 - DVE Layer Objects 2163
- recapturing
 - AAF, relinking to material 489
 - FCP XML 442
 - files 284
 - images to substitute for video
 - source 286
 - media 280
 - VTR, from a 281
- record clip
 - displaying in Batch timeline 1021
 - setting in Batch timeline 1019
- record clip duration
 - changes due to insert edits 1025
 - changes due to ripple replace edits 1029
- record timecode 933
- recovering
 - archives 653
- RectCut button
 - in Paint 2514
- Recursive Clone medium 2445
- redo
 - in Batch 1313
- Redo button
 - on desktop 68
- reels
 - Batch, adding clips 1285
 - loading 591
 - locking on the desktop 55
 - naming on the desktop 59
 - saving 561, 563
 - scrubbing on the desktop 49
- reference area
 - cycling through multiple frames 134
 - displaying 131
 - loading clip into 133
 - moving split bar 131
 - reference overlay 134
 - showing and hiding split bar 132
 - storing frames 133
 - turning split bar on and off 131
- reference box, in Stabilizer 1782
- reference clip
 - See also* contexts
 - in Batch 1264
 - viewing in Colour Warper 1488
- Reference Foot box 410
- reference image, overlay in Batch
 - Paint 2402
- Reformat tool 277
- reformatting
 - clips 273
- refresh
 - Batch, clips as you work 1278
- refreshing view in file browser 89
- Regenerate Proxies
 - Format command 1445
- regenerating proxies 543
- Regrain
 - node in Modular Keyer 1640
- ReGrain tool, using 780
- ReGrain, Processing command 1427
- regraining clips
 - in Batch 1345
- relinking
 - AAF, file-based media 486
 - AAF, to captured material 489
 - FCP XML to file-based media 439
 - files, before reloading 284
 - media 269
 - media to clips 289
- reloading
 - files, imported 284
- remote storage
 - Wiretap, relinking AAF to files 486
- remote systems
 - accessing clip libraries in 593
- Remove Pulldown node in Batch 1335
- removing
 - clips from an edit sequence 1032
- rendering
 - by fields or frames in Keyer 1599
 - clips on desktop 966
 - See also* processing
 - timewarps 1154
- Renumber Events menu 332

- Repeat button
 - in Editing menu 958
- Replace button
 - on Editing menu 954
- replace edits 1029
 - gestural, on desktop 939
- replacing
 - clips, on desktop 955
- Reset All button
 - in Warper 1879
- resetting
 - EQ 1235
 - in Colour Corrector 1460
 - mattes and selectives in Colour Warper 1508
 - RGB gamma or luminance curves for all frames 1522
 - RGB gamma or luminance curves for current frame 1522
- Resize
 - accessing from a clip library 665
 - accessing in Batch 668
 - accessing on export 666
 - accessing on import 666
 - animating settings 688
 - animating the frame size of a clip 689
 - Batch, clips 1288
 - changing the appearance of the crop box 696
 - changing the padding colour 697
 - Default Resolutions list 699
 - default values 695
 - Destination settings 682
 - filters 208, 684
 - fit methods 207, 683
 - Format command 1446
 - loading setups 691
 - node 673
 - node in Batch 1369
 - pan and scan 688
 - processing soft clip handles 694
 - resetting in Batch 696
 - saving setups 689
 - Soft Clip button 694
 - split views 679
- Resize Editor 1138
- Resize module 667
- resizing
 - group 240
- resizing clips
 - about 664
 - from source 685
 - to destination 687
 - using the crop box 685
- resolution
 - See also* resizing clips
 - Batch, using multiple in 1286
 - changing with Reformat tool 273
 - supported AAF 483
- restoring
 - archived setups 655
 - archives 650
- restricting strokes 2380
- Result
 - node in Modular Keyer 1643
- Result node
 - in Batch 1606
- Reveal medium 2444
- revealing
 - sources in Batch Paint 2396
- Reverb 1244
- Reverb Send 1215
- Reverse button
 - in Editing menu 959
- Reverse option, in Channel Editor 2020
- RGB Blur
 - node in Batch 1370
 - node in Modular Keyer 1631
- RGB channels
 - adjusting in Colour Warper 1518
 - combining using Format commands 1447
 - combining using logical operations 1433
 - separating with Format commands 1447
- RGB Viewer 1665
 - See also* ellipsoids in 3D Keyer, 3D Keyer
 - colour values, plotting 1693
 - colour values, selecting 1693

- convex hull, reshaping 1698
- display options 1682
- elements, rotating 1696
- elements, scaling 1696
- elements, selecting 1687
- elements, translating 1696
- manipulating 1682
- resetting 1682
- softness, viewing 1670
- tolerance, viewing 1668
- using in Colour Warper 1489
- RGBA files
 - exporting 248
 - importing 220
- Ripple mode. *See* rippling
- rippling
 - an edit sequence when replacing shots 1029
- ROI (Region of Interest), using with multiple garbage masks 1741
- Roll brush attribute 2385, 2432
- rolls, text 1937
- rotating
 - canvas 2401
- rotating axes, in Action 2173
- rotoscoping 1728, 2408

S

- S button
 - same clips, loading 44
- Safe Title
 - action areas 124
- Safe Title mode
 - in Text module 1932
- Same Clips option 110
- same clips option on desktop 44
- Sample field
 - in Warper 1908
- sampling
 - adjusting in the Tracer 1753
 - colours from clips 73
 - colours in Colour Corrector 1462
 - colours in Colour Warper 1501
- saturation
 - adjusting in Colour Corrector 1468

- correcting colour suppression in Colour Warper 1529
- in Colour Warper 1517
- increasing globally in Colour Warper 1517
- increasing specific hues in Colour Warper 1517
- matching in Colour Warper 1524
- saving
 - EDLs and tape lists 375
 - generated EDLs 395
 - output EDLs 401
 - setups and preferences 803
 - setups in Batch Paint 2404
 - Text files 1918
- scan mode
 - changing default 721
 - changing in the Resize 667
 - changing metadata tag 724
- schematic
 - Batch 1267
 - creating branches, in Action 2110
 - DVE Layer Object expansion 2159
 - garbage mask, viewing 1722
 - in Action 2100
 - navigating in Batch 1270
 - notes in Batch 1271
- Schematic view
 - nodes 1095
 - Wipe Editor 1094
- Screen
 - Logical Operation 1435
- scripts
 - Batch and variables 1326
- scrubbing
 - audio in modules 115
 - audio in Player 1203
 - audio in timeline 1205
 - clips on the desktop 49
 - reels on the desktop 49
- Search Events menu 330
- searching
 - EDLs 346
- searching the desktop 77
- segments in timeline
 - sliding 1059

- slipping 1062
- trimming 1054
- Select button
 - in Warper 1884
- Select mode
 - in Channel Editor 2007
- selecting
 - nodes in Batch 1300
 - tracks for EDLs 395
- selecting all in file browser 89
- selecting clips
 - Timing View 1276
- Selection Mode box, in Batch 1299
- selection sets
 - Channel Editor 1995
- selectives
 - creating in Colour Warper 1502
 - resetting in Colour Warper 1508
- Separate
 - Format command 1445
 - RGB channels with Format commands 1447
- Setup button
 - in Batch 1278
- setups
 - Action, deleting 2130
 - Action, loading 2128
 - adding film grain 795
 - archiving and restoring 655
 - backing up in Modular Keyer 1628
 - backward compatibility 14
 - Batch, loading 1266
 - Batch, saving 1279
 - brushes 2526
 - copying 528
 - defined 799
 - deleting 539
 - garbage masks 1757
 - loading 803
 - LUT Editor, loading 767
 - LUT Editor, saving 766
 - options in Action 2116
 - Paint 2524
 - removing from directories 804
 - removing multiple items 805
 - saving 803
 - saving in Batch Paint 2404
 - saving in Modular Keyer 1628
 - sharing 528
 - sharing between products 15
 - sharing between projects 529
 - text motion path 1946
- Shade medium 2449
- shadows
 - See also* softness
 - colour correcting in Colour Corrector 1467
 - creating with Axis soft effect 1122
 - in Action 2202
 - matching in Colour Warper 1524
 - modifying in Colour Warper 1510
 - removing colour in Colour Warper 1511
- shape animation 2503
- Shape channel, used for garbage mask animation 1728
- shapes, in Graphics (Paint) 2498
- shots, swapping on desktop 961
- simple publish 292
- Simplify option
 - in Channel Editor 2013
- Size brush attribute 2382, 2429
- size estimation, for archiving 615
- sliding
 - audio in timeline 1062
 - elements in timeline, with hot keys 1053
 - segments in timeline 1059
 - transitions in timeline 1061
- slipping
 - audio in timeline 1063
 - clips in the Modular Keyer 1623
 - elements in timeline, with hot keys 1053
 - segments in timeline 1062
- Smear medium 2446
- SMPTE
 - wipes, adding preset 1104
 - wipes. adding 1082
- SMPTE Bars
 - creating with Processing commands 1442

- Frame Mode 1443
- Sobel filter for edge detection 1542
- Soft Clip button 694
- soft clips
 - committing in clip libraries 312
 - force rendering on desktop 967
 - matching with source clips, on desktop 956
- soft edits
 - committing, on desktop 965
 - defined 930
- soft effects
 - accessing editors 1118
 - audio 1207, 1214
 - Axis 1122
 - Axis editor 1125
 - Blend 1136
 - Blend Editor 1136
 - Colour Correction 1134
 - Colour Correction Editor 1134
 - committing selectively 1183
 - compacting 1186
 - copying to Batch schematic 1396
 - creating on timeline 1115
 - creating shadows 1123
 - displaying quick menu 1117
 - editing 1117
 - editing several segments at the same time 1149
 - linking 1149
 - locking 1185
 - muting 1150
 - processing 302
 - Resize 678
 - Resize Editor 1138
 - Resize, creating 1137
 - Sparks, creating 1133
 - Text 1138
 - Text Editor 1138
 - Timewarp, creating 1135
 - viewing in context 1119
 - Wipe 1132
- soft effects, copying 1149
- soft-imported clips
 - archiving 629
- soft-importing
 - about 199
 - audio 229
 - background 227
 - image files 210
- SoftLight
 - Logical Operation 1435
- softness
 - adjusting by plotting colour values in Keyer 1561
 - adjusting in 3D Keyer 1703
 - grain, removing from in 3D Keyer 1673
 - in Colour Warper 1503
 - in Compositor 1765
 - shadows and transparencies, improving in 3D Keyer 1676
 - softness range, defined in Keyer 1562
 - softness range, setting in 3D Keyer 1670
 - softness range, setting in Keyer 1565
- softness border 1743
 - gradient in Tracer, removing 1747
 - separating from mask border 1748
- softness vertices, garbage masks
 - selecting 1725
- software initialization configuration file
 - opening 189
 - using to configure HSDL I/O 189
 - using to configure VTR clip I/O 145
- soloing
 - audio 1208
 - input strips 1224
- sorting
 - clip libraries 572, 577
- sorting in the file browser 87
- source clip
 - defined 932
 - displaying in Batch timeline 1021
 - setting in Batch timeline 1019
- Source Feed box
 - in Player 102
- source nodes in Action
 - anti-aliasing 2218

- applying effects 2214
 - cameras, using 2219
 - creating 2212
 - motion blur 2218
 - parenting 2213
 - replacing front or matte 2215
- Source settings menu 682
- source timecode 933
- sources
 - about 2376
 - adding 2377
 - blending with current image 2398
 - cloning 2394
 - deleting from clip history 815
 - displaying overlays 2381
 - limiting strokes 2380
 - locking 2381
 - removing 2378
 - revealing 2396
 - wiping 2401
- space calculation 860
- Sparks
 - about 1957
 - developing 1960
 - node in Batch 1372
 - replacing currently loaded 1958
 - using as a module 1959
 - using on the desktop 1959
- special effects media
 - Blur 2440
 - Clone 2441
 - Drag 2442
 - Impressionist 2443
 - in graphics 2494
 - Recursive Clone 2445
 - Reveal 2444
 - Shade 2449
 - Smear 2446
 - Stamp 2446
 - Warp 2448
 - Wash 2449
- specular highlight
 - on 3D models, in Action 2280
- speed curve 1157, 1166
- spell checking 1936
- Splice button
 - in Editing menu 948
- splicing
 - all clips on a reel 949
 - clips on desktop, with audio 950
 - clips on desktop, with Splice command 948
- splines
 - in Distort 1834
- split bar
 - moving 131
 - showing and hiding 132
 - turning on and off 131
- Split button
 - in Warper 1887
- Stabilizer
 - accessing 1782
 - Average button 1798
 - correcting errors 1805
 - Fixed-X and Fixed-Y settings 1796
 - from Action 1794
 - gang option 1790
 - importing and exporting data 1819
 - jitter, removing 1796
 - offsets, animating 1805
 - offsets, using 1804
 - oversampling 1815
 - pretracking 1815
 - reference point, selecting 1785
 - rendering options 1814
 - resetting reference and tracker
 - boxes 1788
 - resizing reference and tracker
 - boxes 1789
 - scaling and shifting options 1817
 - setting trackers for 3D tracking 2254
 - setup options 1814
 - shift channels, copying 1818
 - shift values 1783
 - smoothing camera motion 1798
 - tracker and reference boxes 1785
 - tracker box 1806
 - tracker, selecting 1786
 - tracking 1799
 - tracking options 1816
 - using 1782

- Stabilizer button
 - in Warper 1893
 - stabilizing 1793
 - Stamp medium 2446
 - standard EDLs
 - supported 318
 - start and end frames
 - in Batch 1325
 - start and end points
 - See* in and out points
 - start-up options 920
 - start-up volume integrity check 879
 - starting
 - application 919
 - projects 525
 - status webpage for Batch 1279
 - Stone mode archiving 629
 - Stonifise tool 308–309
 - stonifiseTool utility 915
 - storage
 - preferences 860
 - striping a tape. *See* outputting, clips in assemble mode
 - strobing a clip 1173
 - strokes
 - applying 2388
 - blending with current image 2398
 - clearing 2378
 - clearing canvas 2400
 - hiding strokes 2379
 - limiting with source matte 2380
 - limiting, matte 2389
 - stylus. *See* pen and tablet
 - subclips, creating with in and out points 1024
 - Subdirectories list
 - in file browser 85
 - Subdivide button
 - in Warper 1887
 - subsetups in Colour Warper
 - comparing 1533
 - naming 1532
 - replacing 1532
 - saving and loading 1533
 - storing and retrieving 1532
 - substituting, image files for video sources 286
 - Subtitle XML
 - about 465
 - adding to timeline 468
 - editing 469
 - importing 466
 - syntax 470
 - Subtract
 - Logical Operation 1436
 - supported formats
 - EDLs 318
 - suppressing
 - colour spills in Colour Warper 1529
 - colours in Colour Corrector 1472
 - colours in Colour Warper 1515
 - surfaces
 - particle generation, in Action 2326
 - surfaces in Action
 - adding 2178
 - applying media 2179
 - bicubic 2183
 - bilinear 2183
 - changing order 2204
 - offsetting 2187
 - Swap option
 - in Channel Editor 2019
 - Swap Shot button
 - in Editing menu 961
 - swapping shots
 - on desktop, with audio 962
 - syntax
 - subtitle XML 470
 - system
 - freezes, what to do 923
 - messages 41
- ## T
- tab stops
 - setting in Text 1935
 - table of contents
 - deleting 647
 - using to recover an archive 653
 - XML/HTML 643

- tablet
 - initialising 923
 - preferences 830
- tangent handles
 - automatic adjustment, adjacent handles 1727
 - automatic adjustment, reversing behaviour 1727
 - automatic, enabling 1716
 - breaking and reconnecting in garbage masks 1726
 - hiding in Channel Editor 1989
 - moving, in garbage masks 1726
 - removing in garbage masks 1726
 - scaling in garbage masks 1726
 - selecting, in garbage masks 1725
- tape
 - logging and capturing FCP XML 433
- tape archives
 - creating 625
 - opening 632
 - pros and cons 604
- Tape List view 358
- tape lists
 - recapture, accessing 281
 - saving 375
- tape name
 - editing in EDL 361
- target clip
 - defined 932
- telecine log files
 - supported 318
 - supported data types 341
- templates
 - for SMPTE wipes 1104
- test disks
 - in Preferences menu 861
- Test Disks utility 882
- Text
 - adding text to a clip 1921
 - animating 1941
 - animating paragraphs 1942
 - Asian character sets 1925
 - copying character channels 1933
 - creating roll 1939
 - creating text layers 1921
 - fonts, Asian 1925
 - fonts, using 1951
 - formatting in Text module 1926
 - grouping layers 1933
 - in Paint 2485
 - loading files 1919
 - loading logos 1934
 - locking layers 1930
 - mattes, generating in Soft Text 1139
 - modifying layer properties 1928
 - on-screen keyboard 1925
 - opening the Text module 1911
 - resizing 1932
 - saving files 1918
 - Setup menu 1913
 - spell checking 1936
 - styles, loading and saving 1949
 - tab stops 1935
 - text columns 1935
 - text motion paths, creating 1944
 - text rolls and crawls 1937
 - text styles, defining 1947
- Text Editor 1138
- text fields 39
 - using X-copy to enter text 39
- Text node in Batch 1373
- text objects, in Paint 2485
- Text soft effect 1138
- texture mapping
 - in Action 2284
- textures
 - particles, applying 2339
 - projecting in Action 2289
- three-point edits 1030
- timecode
 - about 404
 - assigning manually 423
 - Burn In Timecode node in Batch 1342
 - burning in 428
 - calculator 409
 - changing 413, 418
 - displaying 405
 - displaying in clip information overlay 408
 - displaying in List view 409

- displaying in Player 407
- displaying in timeline 408
- editing in EDLs 367
- record 933
- removing conflicts 425
- source 933
- timecodes
 - Batch, setting in Queue Manager 1324
 - using the calculator 70
- timeline 1016, 1208
 - adding subtitle XML 468
 - animated soft effects,trimming 1144
 - audio soft effects 1207
 - audio waveforms 1207
 - changing duration of edit
 - sequence 1021
 - comments, adding 986
 - committing clips 1182
 - consolidating elements 1181
 - containers, creating 1041
 - creating audio fades 1209
 - creating effects on empty layers 1145
 - creating fade-ins and fade-outs 1081
 - cue marks 1007
 - displaying keycode and timecode 408
 - displaying large view 975
 - displaying phantom inserts 1024
 - dragging shots 1023
 - element information,
 - displaying 987
 - elements, naming 986
 - elements, removing 988
 - elements, searching 989
 - elements, selecting 984
 - entering Batch setup 1376
 - frame-stepping 977
 - frame, jumping to 976
 - gap effects, creating 1145
 - gaps 1041
 - head and tail information 1049
 - interface 971
 - layers, collapsing 1039
 - layers, creating 1037
 - layers, hiding from output 1039
 - linking transitions and cuts 1052
 - locking elements 1185
 - locking segments while
 - trimming 1051
 - maintaining sync 992
 - merging layers 1183
 - muting audio 1208
 - muting soft effects 1150
 - navigating between cuts 977
 - overwriting clips in edit
 - sequence 1027
 - overwriting clips with gaps 1027
 - panning 973
 - partial processing 1187
 - patching 997–998
 - placing shots gesturally 1021
 - playing 975
 - preferences 841
 - process status 1180
 - processing effects 302
 - removing clutter 1041
 - Resize soft effects, creating 1137
 - rippling elements 1021
 - saving Batch clips 1188
 - scrolling 973
 - scrubbing 976
 - scrubbing audio 1205
 - segment marks 1007
 - setting snap options 1022
 - sliding transitions 1061
 - slipping segments 1062
 - soft effect editors 1118
 - soft effects, copying 1149
 - soft effects, creating 1115
 - soft effects, deleting 1151
 - soft effects, editing 1117
 - soft effects, viewing in context 1119
 - Sparks soft effects, creating 1133
 - timecode, jumping to 976
 - Timewarp soft effects, creating 1135
 - tracks, adding 978
 - tracks, current 979
 - tracks, locking 982
 - tracks, naming 983
 - tracks, resizing 982

- tracks, selecting 980
- trimming audio 1059
- unlinking clips 1184
- vertical editing interface 1036
- virtual sources, using 933
- working with audio 1204
- zooming 974
- timewarp
 - using external motion data in
 - Batch 1176
- Timewarp Editor
 - using from Batch timeline 1165
 - using from desktop 1157
- timewarps
 - aborting, on desktop 1156
 - Auto Key, using with 1160
 - constant and variable 1157, 1161
 - copying from one segment to
 - another 1165
 - creating complex 1157, 1165
 - creating in Batch timeline 1160
 - creating on the desktop 1154
 - cutting, on desktop 945
 - deleting from Batch timeline 1165
 - editing constant 1163
 - explicit and implicit 1161
 - fit-to-fill 1162
 - force rendering on desktop 967
 - frame rate, converting with 1164
 - in EDLs 370
 - motion estimation in Batch
 - timeline 1172
 - motion estimation with Batch
 - nodes 1174
 - on virtual sources 1170
 - posttrail and pretrail 1159
 - rendering, in Batch timeline 1168
 - rendering, on desktop 1154
 - resetting in Batch timeline 1164
 - reversing 1154
 - soft, defined 931
 - speed curve and timing curve 1157, 1166
 - strobe effect, creating 1173
 - timing curve, scaling
 - automatically 1160
 - trail effects 1170
 - trimming in Batch timeline 1168
 - variable speed, creating 1167
- timing
 - preferences 829
 - scale for channels 2008
- timing curve 1157, 1166
- Timing View 1274
 - offsetting clips 1277
 - selecting clips 1276
- Titles group 351
- Titles mode, in clip libraries 567
- TLC
 - files loading 343
- to_framestore utility
 - remote access 886
 - restrictions 898, 901
- TOC. *See* table of contents
- tolerance
 - adjusting by plotting colour values in
 - Keyer 1561
 - in Colour Warper 1503
 - tolerance range, setting in 3D
 - Keyer 1666
 - tolerance range, setting in
 - Keyer 1567
- tooltips
 - preferences 835
- Total Frames field 111
- Tracer
 - advanced gradient mode 1743
 - animating 1752
 - animating pickers 1753
 - defined 1709
 - matte, fine-tuning 1750
 - pickers, defined 1746
 - pulling keys 1743
 - troubleshooting 1756
 - when to use 1743
- Track Editor
 - accessing 1965
 - channel view 1968
 - translating track 2012
- Track Table 395
- tracker box, in Stabilizer 1785, 1806
- Tracker. *See* Stabilizer

- tracking
 - animating garbage masks 1735
 - animating selected vertices on garbage masks 1737
 - by axis in Distort 1856
 - by axis in Warper 1892
 - by vertices in Distort 1857
 - by vertices in Warper 1893
 - in Compositor 1774
 - in Paint 2463
 - live-action clips in Warper 1891
 - rotation information 1800
 - scaling information 1800
 - wipe tangents 1092
 - tracks
 - activating output channels 979
 - adding to timeline 978
 - changing current track on timeline 979
 - locking 982
 - naming 983
 - resizing 982
 - selecting 980, 2007
 - selecting for EDLs 395
 - snapping keyframes to frames 2006
 - trail effects 1159
 - transformations
 - garbage masks, applying 1724
 - transitions
 - AAF, supported 491
 - creating Axis 1107
 - in EDLs 365
 - OMF, supported 505
 - replacing shots between, on desktop 961
 - sliding in timeline 1061
 - soft, defined 931
 - supported in FCP XML 443
 - Transitions group 351
 - transparencies
 - adjusting with patches in 3D Keyer 1705
 - using YUV softness 1676
 - Transparency field 2469
 - triangles
 - painting 2425
 - trim cursors 1046, 1063
 - in timeline 1051
 - trimming
 - animated soft effects 1144
 - audio in timeline 1059
 - dissolves in timeline 1058
 - elements in timeline,
 - gesturally 1054
 - elements in timeline, with hot keys 1053
 - gestural 1047
 - linking transitions and cuts in timeline 1052
 - locking segments in timeline 1051
 - timewarps in Batch timeline 1168
 - trim operations defined 1046
 - troubleshooting
 - lock files 600
 - TrueType fonts
 - installing 876
- ## U
- Unbypass button in Batch 1280
 - undo
 - Batch, setting number of 1280
 - in Batch 1313
 - Undo list
 - EDLs 357
 - undoing on the desktop 68
 - Universal Channel Editor 2029
 - defined 1273
 - linking channel animations 2035
 - synchronizing animations 2031
 - unlinking
 - media 269
 - unlocking
 - clips duration 2408
 - Unrendered Frame message 1156
 - unrendering 305
 - unselecting in the file browser 89
 - USB storage devices, archiving to 629
 - user interface
 - customizing 832
 - preferences 831

- users
 - copying preferences 546
 - creating 546
 - deleting 549
 - managing 524
 - modifying 548
 - sharing preferences 546
 - switching 551
 - upgrade compatibility 12
- users guide
 - conventions 4
 - PDF format 5
- utilities
 - cmtool 890
 - determining version 886
 - disk testing 882
 - fcof 912
 - from_framestore 899
 - imcopy 901
 - iminfo 911
 - list 894
 - list_framestore 895
 - log files 882
 - parameters 887
 - publishTool 913
 - remote access 886
 - restrictions 898, 901
 - stonifiseTool 915
 - summary (table) 878
 - to_framestore 896
 - vic 917
 - vstat 916

V

- variable speed timewarps 1157, 1161, 1167
- Varicam
 - importing with EDLs 338
- Vector Viewer
 - displaying motion vectors 1178
 - using external motion data in Batch 1176
- vectors
 - in expressions 2040

- vertical editing
 - components 1036
- vertices
 - manipulating on convex hull in 3D Keyer 1699
- vertices in garbage masks
 - activating and deactivating 1733
 - adding and removing 1733
 - adjusting number drawn freehand 1722
 - animating 1730
 - animating on different channels 1730
 - applying tracking data 1737
 - deleting 1735
 - moving 1726
 - selecting 1725
 - setting keyframing options 1731
- vic utility 917
- video
 - AAF, supported effects 495
 - AAF, supported transitions 491
 - audio sync in Player 105
 - converting audio 1252
 - export options, files 244
 - exporting files 251
 - HD formats, supported for clip I/O 168
 - importing files 224
 - OMF, supported effects 510
 - OMF, supported transitions 505
- video I/O
 - See* clip I/O 151
- video I/O timing
 - preferences 829
 - setting initial 145
- Video I/O Timing box 177
- view modes
 - in clip libraries 567
- viewing
 - Batch, options 1265
- viewports
 - in Colour Warper 1488
- virtual sources
 - creating with Processing commands 1442

- in timeline 933
- matte containers, creating 1123
- volume integrity checking utility. *See* *vic utility*
- vstat utility 916
- VTR archives
 - creating 621
 - header information slate 620
 - opening 631
 - pros and cons 604
- VTRs
 - outputting clips 153
 - Standby status 173
 - using for clip input 146

W

- Warp
 - medium 2448
- Warp button in Warper 1878
- Warper
 - adding a vertex 1887
 - adjusting the magnet size 1889
 - automatically creating destination meshes 1901
 - Break button 1886
 - clips, managing 1880
 - copying and pasting meshes 1895
 - copying tracking data 1894
 - creating a freehand mesh 1888
 - creating the transition between clips 1901
 - customizing the Magnet effects 1889
 - destination mesh for morphing 1899
 - generating tracking data 1893
 - in Warper module, accessing 1878
 - keyframes, setting manually 1902
 - loading clips 1878
 - locking the back clip 1898
 - Magnet Curve Editor 1889
 - meshes for live-action clips 1891
 - meshes, adding 1881
 - meshes, creating 1880
 - modelling controls 1883

- morphing between live-action clips 1904
- morphing between still clips 1903
- morphing one image into another 1899
- Move button 1886
- moving edges 1884
- moving tangent handles 1884
- patches, adding 1882
- patches, deleting 1882
- performing a regional warp 1898
- proportional mesh 1882
- redimensioning meshes 1885
- resetting broken tangent handles 1887
- rotating meshes 1885
- scaling meshes 1885
- selecting multiple vertices 1884
- source and destination meshes 1880
- source interpolation, using 1901
- source mesh for morphing 1899
- Stabilizer, loading clips 1892
- subdividing a patch 1887
- tangent handles, breaking 1885
- tangent handles, unbreaking 1887
- tracking and stabilizing 1892
- tracking by axis 1892
- tracking by vertices 1893
- translating meshes 1885
- using animation curves 1901
- using the magnet 1889
- vertices, moving 1884
- warping a still clip 1898
- warping and morphing, defined 1877
- warping with the Magnet 1889
- warping
 - colours after correction, in Colour Warper 1528
 - spline-based versus mesh-based 1825
 - with Distort 1822
 - with the Warper 1877
- Wash medium 2449
- Weighted and Uniform box 1429
- widescreen viewing 112

- Wipe command
 - in AutoPaint 2458
 - in Paint 2451
- Wipe soft effect 1132
- wipes
 - AAF, supported 491
 - adding elements 1095
 - adjusting the global axis 1083
 - animating masks 1094
 - changing mask shape 1088
 - controlling mask effect 1088
 - copying elements 1098
 - creating masks 1086
 - custom, creating with garbage masks 1085
 - customized SMPTE, creating and modifying 1084
 - deleting elements 1101
 - editing 1084
 - hiding elements 1099
 - in EDLs 366
 - mask transforms 1091
 - naming elements 1096
 - OME, supported 505, 510
 - Schematic view 1094
 - selecting elements 1096
 - smoothing edges 1090
 - SMPTE, creating 1082
 - SMPTE, preset 1104
 - templates for SMPTE 1104
 - tracking masks 1092
- wiping 2401
- Wire transfers, aborting 600
- wireframe
 - converting 3D models, in Action 2289
 - converting to, in Action 2317
 - in garbage masks 1716

- wireframe display options 2490
- Wiretap
 - relinking to files in AAF 486
- workflow 1283
 - Batch 1262
 - Batch process tree 1283
 - Batch, motion estimation 1176

X

- XML
 - See also* FCP XML subtitle 465
- XML table of contents
 - viewing archives with 643
- Xnor
 - Logical Operation 1436
- Xor
 - Logical Operation 1436

Y

- YUV material, inputting and outputting 180

Z

- Z-buffer
 - in Action 2208
- Z-Buffer box
 - shadows, in Action 2204
- Zoom mode 2415
 - camera, in Action 2236
 - in Channel Editor 1999
- zooming
 - the image window 112

