

AUTODESK®
EFFECTS and EDITING
2008

HP® xw8400 WORKSTATION

Hardware Setup Guide

Autodesk®

© 2007 Autodesk, Inc. All rights reserved. Except as otherwise permitted by Autodesk, Inc., this publication, or parts thereof, may not be reproduced in any form, by any method, for any purpose.

Certain materials included in this publication are reprinted with the permission of the copyright holder.

Portions of this software are copyright © 2.1.19 The FreeType Project (www.freetype.org). All rights reserved.

Portions relating to Python version 2.3.3 Copyright © 2001, 2002, 2003 Python Software Foundation; All Rights Reserved.

Portions relating to Python version 2.1.1 Copyright © 2001 Python Software Foundation; All Rights Reserved.

Portions relating to libxalan-c version 1.8.0 are copyright Apache version 2.0 Copyright 2004 The Apache Software Foundation. Licensed under the Apache License, Version 2.0 (the "License"); you may not use this file except in compliance with the License. You may obtain a copy of the License at <http://www.apache.org/licenses/LICENSE-2.0>. Unless required by applicable law or agreed to in writing, software distributed under the License is distributed on an "AS IS" BASIS, WITHOUT WARRANTIES OR CONDITIONS OF ANY KIND, either express or implied. See the License for the specific language governing permissions and limitations under the License.

This product includes software developed by the Apache Software Foundation (<http://www.apache.org/>).

THIS PRODUCT IS LICENSED UNDER THE MPEG-4 VISUAL PATENT LICENSE PORTFOLIO LICENSE FOR THE PERSONAL AND NON-COMMERCIAL USE OF A CONSUMER FOR (i) ENCODING VIDEO IN COMPLIANCE WITH THE MPEG-4 VISUAL STANDARD ("MPEG-4 VIDEO") AND/OR (ii) DECODING MPEG-4 VIDEO THAT WAS ENCODED BY A CONSUMER ENGAGED IN A PERSONAL AND NON-COMMERCIAL ACTIVITY AND/OR WAS OBTAINED FROM A VIDEO PROVIDED LICENSED BY MPEG LA TO PROVIDE MPEG-4 VIDEO. NO LICENSE IS GRANTED OR SHALL BE IMPLIED FOR ANY OTHER USE. ADDITIONAL INFORMATION INCLUDING THAT RELATING TO PROMOTIONAL, INTERNAL USES AND LICENSING MAY BE OBTAINED FROM MPEG LA, LLC. SEE [HTTP://WWW.MPEGLA.COM](http://WWW.MPEGLA.COM).

THIS PRODUCT IS LICENSED UNDER THE MPEG-2 PATENT PORTFOLIO LICENSE ANY USE OF THIS PRODUCT OTHER THAN CONSUMER PERSONAL USE IN ANY MANNER THAT COMPLIES WITH THE MPEG-2 STANDARD FOR ENCODING VIDEO INFORMATION FOR PACKAGED MEDIA IS EXPRESSLY PROHIBITED WITHOUT A LICENSE UNDER APPLICABLE PATENTS IN THE MPEG-2 PATENT PORTFOLIO, WHICH LICENSE IS AVAILABLE FROM MPEG LA, L.L.C., 250 STEELE STREET, SUITE 300, DENVER, COLORADO 80206.

Portions relating to libffmpeg Copyright © 2003-2006, Fabrice Bellard.

Portions relating to ALSA version 1.0.6 Copyright © 2004 Jaroslav Kysela, Abramo Bagnara, Takashi Iwai, and Frank van de Pol.

Powered by Automatic Duck. © 2006 Automatic Duck, Inc. All rights reserved.

Portions relating to Audiobogus Copyright © 1998-1999, Michael Pruett (michael@68k.org).

Portions relating to xxdiff Copyright © 1999-2004, Martin Blais. All Rights Reserved.

Portions relating to Audiofile 0.2.6, Open Inventor 2.1.5-9, and LibImageDL software are Copyright © 1991, 1999 Free Software Foundation, Inc.

Portions relating to GLEE Copyright ©2006 Ben Woodhouse. All rights reserved. Redistribution and use in source and binary forms, with or without modification, are permitted provided that the following conditions are met: 1. Redistributions of source code must retain the above copyright notice, this list of conditions and the following disclaimer as the first lines of this file unmodified. 2. Redistributions in binary form must reproduce the above copyright notice, this list of conditions and the following disclaimer in the documentation and/or other materials provided with the distribution. THIS SOFTWARE IS PROVIDED BY BEN WOODHOUSE "AS IS" AND ANY EXPRESS OR IMPLIED WARRANTIES, INCLUDING, BUT NOT LIMITED TO, THE IMPLIED WARRANTIES OF MERCHANTABILITY AND FITNESS FOR A PARTICULAR PURPOSE ARE DISCLAIMED. IN NO EVENT SHALL BEN WOODHOUSE BE LIABLE FOR ANY DIRECT, INDIRECT, INCIDENTAL, SPECIAL, EXEMPLARY, OR CONSEQUENTIAL DAMAGES (INCLUDING, BUT NOT LIMITED TO, PROCUREMENT OF SUBSTITUTE GOODS OR SERVICES; LOSS OF USE, DATA, OR PROFITS; OR BUSINESS INTERRUPTION) HOWEVER CAUSED AND ON ANY THEORY OF LIABILITY, WHETHER IN CONTRACT, STRICT LIABILITY, OR TORT (INCLUDING NEGLIGENCE OR OTHERWISE) ARISING IN ANY WAY OUT OF THE USE OF THIS SOFTWARE, EVEN IF ADVISED OF THE POSSIBILITY OF SUCH DAMAGE.

Portions relating to Mesa Copyright ©1999-2007 Brian Paul. All Rights Reserved. Permission is hereby granted, free of charge, to any person obtaining a copy of this software and associated documentation files (the "Software"), to deal in the Software without restriction, including without limitation the rights to use, copy, modify, merge, publish, distribute, sublicense, and/or sell copies of the Software, and to permit persons to whom the Software is furnished to do so, subject to the following conditions: The above copyright notice and this permission notice shall be included in all copies or substantial portions of the Software. THE SOFTWARE IS PROVIDED "AS IS", WITHOUT WARRANTY OF ANY KIND, EXPRESS OR IMPLIED, INCLUDING BUT NOT LIMITED TO THE WARRANTIES OF MERCHANTABILITY, FITNESS FOR A PARTICULAR PURPOSE AND NONINFRINGEMENT. IN NO EVENT SHALL BRIAN PAUL BE LIABLE FOR ANY CLAIM, DAMAGES OR OTHER LIABILITY, WHETHER IN AN ACTION OF CONTRACT, TORT OR OTHERWISE, ARISING FROM, OUT OF OR IN CONNECTION WITH THE SOFTWARE OR THE USE OR OTHER DEALINGS IN THE SOFTWARE.

Portions relating to OpenExr 1.2.1 Copyright (c) 2004, Industrial Light & Magic, a division of Lucasfilm Entertainment Company Ltd. Portions contributed and copyright held by others as indicated. All rights reserved. Redistribution and use in source and binary forms, with or without modification, are permitted provided that the following conditions are met: Redistributions of source code must retain the above copyright notice, this list of conditions and the following disclaimer. Redistributions in binary form must reproduce the above copyright notice, this list of conditions and the following disclaimer in the documentation and/or other materials provided with the distribution. Neither the name of Industrial Light &

Magic nor the names of any other contributors to this software may be used to endorse or promote products derived from this software without specific prior written permission. THIS SOFTWARE IS PROVIDED BY THE COPYRIGHT HOLDERS AND CONTRIBUTORS "AS IS" AND ANY EXPRESS OR IMPLIED WARRANTIES, INCLUDING, BUT NOT LIMITED TO, THE IMPLIED WARRANTIES OF MERCHANTABILITY AND FITNESS FOR A PARTICULAR PURPOSE ARE DISCLAIMED. IN NO EVENT SHALL THE COPYRIGHT OWNER OR CONTRIBUTORS BE LIABLE FOR ANY DIRECT, INDIRECT, INCIDENTAL, SPECIAL, EXEMPLARY, OR CONSEQUENTIAL DAMAGES (INCLUDING, BUT NOT LIMITED TO, PROCUREMENT OF SUBSTITUTE GOODS OR SERVICES; LOSS OF USE, DATA, OR PROFITS; OR BUSINESS INTERRUPTION) HOWEVER CAUSED AND ON ANY THEORY OF LIABILITY, WHETHER IN CONTRACT, STRICT LIABILITY, OR TORT (INCLUDING NEGLIGENCE OR OTHERWISE) ARISING IN ANY WAY OUT OF THE USE OF THIS SOFTWARE, EVEN IF ADVISED OF THE POSSIBILITY OF SUCH DAMAGE.

Portions relating to Libpopt Copyright ©1998 Red Hat Software. Permission is hereby granted, free of charge, to any person obtaining a copy of this software and associated documentation files (the "Software"), to deal in the Software without restriction, including without limitation the rights to use, copy, modify, merge, publish, distribute, sublicense, and/or sell copies of the Software, and to permit persons to whom the Software is furnished to do so, subject to the following conditions: The above copyright notice and this permission notice shall be included in all copies or substantial portions of the Software. THE SOFTWARE IS PROVIDED "AS IS", WITHOUT WARRANTY OF ANY KIND, EXPRESS OR IMPLIED, INCLUDING BUT NOT LIMITED TO THE WARRANTIES OF MERCHANTABILITY, FITNESS FOR A PARTICULAR PURPOSE AND NONINFRINGEMENT. IN NO EVENT SHALL THE X CONSORTIUM BE LIABLE FOR ANY CLAIM, DAMAGES OR OTHER LIABILITY, WHETHER IN AN ACTION OF CONTRACT, TORT OR OTHERWISE, ARISING FROM, OUT OF OR IN CONNECTION WITH THE SOFTWARE OR THE USE OR OTHER DEALINGS IN THE SOFTWARE. Except as contained in this notice, the name of the X Consortium shall not be used in advertising or otherwise to promote the sale, use or other dealings in this Software without prior written authorization from the X Consortium.

Portions relating to DIRAC Time Stretch/Pitch Shift technology licensed from The DSP Dimension, <http://www.dspdimension.com> Developed and (c) 2005 Stephan M. Bernsee

Portions relating to Berkeley DB software Copyright ©1990-2002, Sleepycat Software. All rights reserved. Redistribution and use in source and binary forms, with or without modification, are permitted provided that the following conditions are met: 1. Redistributions of source code must retain the above copyright notice, this list of conditions and the following disclaimer. 2. Redistributions in binary form must reproduce the above copyright notice, this list of conditions and the following disclaimer in the documentation and/or other materials provided with the distribution. 3. Redistributions in any form must be accompanied by information on how to obtain complete source code for the DB software and any accompanying software that uses the DB software. The source code must either be included in the distribution or be available for no more than the cost of distribution plus a nominal fee, and must be freely redistributable under reasonable conditions. For an executable file, complete source code means the source code for all modules it contains. It does not include source code for modules or files that typically accompany the major components of the operating system on which the executable file runs. THIS SOFTWARE IS PROVIDED BY SLEEPYCAT SOFTWARE "AS IS" AND ANY EXPRESS OR IMPLIED WARRANTIES, INCLUDING, BUT NOT LIMITED TO, THE IMPLIED WARRANTIES OF MERCHANTABILITY, FITNESS FOR A PARTICULAR PURPOSE, OR NON-INFRINGEMENT, ARE DISCLAIMED. IN NO EVENT SHALL SLEEPYCAT SOFTWARE BE LIABLE FOR ANY DIRECT, INDIRECT, INCIDENTAL, SPECIAL, EXEMPLARY, OR CONSEQUENTIAL DAMAGES (INCLUDING, BUT NOT LIMITED TO, PROCUREMENT OF SUBSTITUTE GOODS OR SERVICES; LOSS OF USE, DATA, OR PROFITS; OR BUSINESS INTERRUPTION) HOWEVER CAUSED AND ON ANY THEORY OF LIABILITY, WHETHER IN CONTRACT, STRICT LIABILITY, OR TORT (INCLUDING NEGLIGENCE OR OTHERWISE) ARISING IN ANY WAY OUT OF THE USE OF THIS SOFTWARE, EVEN IF ADVISED OF THE POSSIBILITY OF SUCH DAMAGE.

Portions copyright 1991-2006 Compuware Corporation.

Trademarks

The following are registered trademarks or trademarks of Autodesk, Inc., in the USA and other countries: 3DEC (design/logo), 3December, 3December.com, 3ds Max, ActiveShapes, Actrix, ADI, Alias, Alias (swirl design/logo), AliasStudio, Alias|Wavefront (design/logo), ATC, AUGI, AutoCAD, AutoCAD Learning Assistance, AutoCAD LT, AutoCAD Simulator, AutoCAD SQL Extension, AutoCAD SQL Interface, Autodesk, Autodesk Envision, Autodesk Insight, Autodesk Intent, Autodesk Inventor, Autodesk Map, Autodesk MapGuide, Autodesk Streamline, AutoLISP, AutoSnap, AutoSketch, AutoTrack, Backdraft, Built with ObjectARX (logo), Burn, Buzzsaw, CAiCE, Can You Imagine, Character Studio, Cinestream, Civil 3D, Cleaner, Cleaner Central, ClearScale, Colour Warper, Combustion, Communication Specification, Constructware, Content Explorer, Create>what's>Next> (design/logo), Dancing Baby (image), DesignCenter, Design Doctor, Designer's Toolkit, DesignKids, DesignProf, DesignServer, DesignStudio, Design|Studio (design/logo), Design Your World, Design Your World (design/logo), DWE, DWG, DWG (logo), DWG TrueConvert, DWG TrueView, DXF, EditDV, Education by Design, Extending the Design Team, FBX, Filmbox, FMDesktop, FreeWheel, GDX Driver, Gmax, Heads-up Design, Heidi, HOOPS, HumanIK, i-drop, iMOUT, Incinerator, IntroDV, Inventor, Inventor LT, Kaydara, Kaydara (design/logo), LocationLogic, Lustre, Maya, Mechanical Desktop, MotionBuilder, ObjectARX, ObjectDBX, Open Reality, PolarSnap, PortfolioWall, Powered with Autodesk Technology, Productstream, ProjectPoint, Reactor, RealDWG, Real-time Roto, Render Queue, Revit, Showcase, SketchBook, StudioTools, Topobase, Toxik, Visual, Visual Bridge, Visual Construction, Visual Drainage, Visual Hydro, Visual Landscape, Visual Roads, Visual Survey, Visual Syllabus, Visual Toolbox, Visual Tugboat, Visual LISP, Voice Reality, Volo, and Wiretap.

The following are registered trademarks or trademarks of Autodesk Canada Co. in the USA and/or Canada and other countries: Backburner, Discreet, Fire, Flame, Flint, Frost, Inferno, Multi-Master Editing, River, Smoke, Sparks, Stone, Wire.

Automatic Duck and the duck logo are trademarks of Automatic Duck, Inc. All other brand names, product names or trademarks belong to their respective holders.

Disclaimer

THIS PUBLICATION AND THE INFORMATION CONTAINED HEREIN IS MADE AVAILABLE BY AUTODESK, INC. "AS IS." AUTODESK, INC., DISCLAIMS ALL WARRANTIES, EITHER EXPRESS OR IMPLIED, INCLUDING BUT NOT LIMITED TO ANY IMPLIED WARRANTIES OF MERCHANTABILITY OR FITNESS FOR A PARTICULAR PURPOSE REGARDING THESE MATERIALS.

Published by:

Autodesk, Inc.

111 McInnis Parkway

San Rafael, CA 94903, USA

Title: Autodesk Effects and Editing 2008 HP xw8400 Workstation Hardware Setup Guide

Document Version: 1

Date: December 18, 2007

contents

Contents

1	Introduction	1
	Summary	1
	About This Guide	1
	Related Documentation	1
	Workflow for Hardware Setup and Application Installation	3
	Hardware Configuration Guidelines	3
	Notation Conventions	9
	Contacting Customer Support	9
2	Connecting Peripherals	11
	Summary	11
	Peripherals Connection Diagrams	11
	Connecting the Keyboard, Mouse, and Tablet	14
	Network Connections	14
	Connecting Storage	15
3	Setting Up Video Hardware	17
	Summary	17
	Video Hardware Components	17
	Wiring Your HP xw8400 in a 2K or HD Configuration	18
	Wiring Your HP xw8400 in an SD Configuration	20
	Standard VTR Control Cable	23
	Setting Up VTR Emulation	23
	Updating AJA OEM-2K PCI-X Firmware	27

Miranda DVI-Ramp Firmware Update..... 29

4 Setting Up Audio Hardware 33

Summary 33
About Audio 33
Audio Wiring Workflow 33
Audio Hardware Components 34
Understanding Remote vs. Local Control of the Lucid Converter 35
Wiring Audio Hardware in a 2K or HD Configuration 35
Wiring Audio Hardware in an SD Configuration 37
Configuring the Lucid ADA 88192 Converter 38
Audio Keywords in the Software Initialisation Configuration File 40

Index 41

Summary

About This Guide	1
Related Documentation	1
Workflow for Hardware Setup and Application Installation	3
Hardware Configuration Guidelines	3
Notation Conventions	9
Contacting Customer Support	9

About This Guide

This guide describes how to set up the HP® xw8400 workstation for your Autodesk® Effects or Editing application.

Use this guide in conjunction with the *Software Installation Guide for Linux Workstations*, the *Configuration File Reference Guide for Linux Workstations*, the *Stone Direct Configuration Guide*, and the *Stone and Wire Filesystem and Networking Guide* to install and configure the hardware and software components of your Effects or Editing products.

NOTE: In most cases, both hardware setup and application installation is done on delivery by an authorized technician, so you may not need to perform some of the procedures in these guides.

The latest versions of all guides are available in PDF format from the Web at <http://www.autodesk.com/discreet-documentation>. Use XPDF or Adobe® Acrobat® Reader™ to view and print the PDF files.

Related Documentation

The following tables list the documentation associated with the current release. For details on each of these documents, as well as for help obtaining them, refer to your application's release notes.

User and Reference Guides	Description
<i>User's Guide</i>	Detailed instructions on using the application
<i>What's New</i>	A complete list of the new features for this release
<i>Online Help</i>	All of the information in the User's Guide along with powerful search functionality
<i>Hot Keys Reference Guide</i>	A complete list of hot keys for commonly used functions
<i>Hot Keys Card</i>	A list of the most frequently used hot keys
<i>Release Notes</i>	A complete list of documentation and information on late-breaking features
<i>Fixed and Known Bug List</i>	A complete list of fixed and known bugs for this release
Installation and Configuration Guides	Description
<i>Hardware Setup Guide</i> (for your workstation)	Information on how to set up your workstation's video I/O components and other peripherals
<i>Installation and Configuration Guide</i> (for your operating system)	Information on how to install and configure the Linux® or IRIX® operating system on your workstation should you require to do so
<i>Stone and Wire Filesystem and Networking Guide</i> (for this release)	Procedures for configuring your Autodesk Stone® filesystem, Autodesk Wire® networking, and Autodesk Wiretap™ services
<i>Stone Direct Configuration Guide</i> (for this release)	Detailed connectivity diagrams and configuration procedures for your Stone storage arrays
<i>Software Installation Guide</i> (for Linux or IRIX workstations)	Information about installing and licensing your Autodesk Editing or Effects software and installing and configuring Autodesk Cleaner® XL
<i>Configuration File Reference Guide</i> (for Linux or IRIX workstations)	Information on how to modify the initialization and project configuration files associated with your Autodesk application
Other Product Reference Guides	Description
<i>Autodesk Cleaner XL User's Guide</i>	Information on how to use Cleaner XL
<i>Autodesk Cleaner XL Troubleshooting Guide</i>	Troubleshooting information for Cleaner XL
<i>Using QuickTime with Linux Workstations</i>	Information on how to use Cleaner XL to convert QuickTime® files for use on Linux workstations
<i>Autodesk Burn Installation and User's Guide</i>	Information on how to install, set up, and use Autodesk Burn™

Other Product Reference Guides	Description
<i>Autodesk Backburner Installation and User's Guide</i>	Information on how to install, set up, and use Autodesk Backburner™
<i>Autodesk Wiretap Web Installation and User's Guide</i>	Information on how to install, set up, and use Autodesk Wiretap™ Web

Consult the Autodesk Web site at www.autodesk.com/discreet-documentation for the latest version of all documents.

Workflow for Hardware Setup and Application Installation

The following procedure provides the general workflow for installing an Autodesk Effects or Editing application on a Linux workstation.

To install an Effects or Editing application on a Linux workstation:

1. Review the guidelines for working with hardware components. See [“Hardware Configuration Guidelines”](#) on page 3.
2. Connect all peripherals (mouse, keyboard, Wacom® tablet, graphics monitor) to the proper ports, and connect your workstation to the Autodesk Wire network. See [“Peripherals Connection Diagrams”](#) on page 11.
3. Connect your workstation to Autodesk Stone Direct storage. See [“Connecting Storage”](#) on page 15.
4. Connect a VTR and a broadcast monitor to your workstation. See [“Wiring Your HP xw8400 in a 2K or HD Configuration”](#) on page 18 or [“Wiring Your HP xw8400 in an SD Configuration”](#) on page 20.
5. Set up the audio hardware. See [Chapter 4, “Setting Up Audio Hardware.”](#) on page 33.
6. Perform the procedures in the *Software Installation Guide* for your product to install and license your Effects or Editing application, and to install Cleaner XL (if you are using Cleaner XL with your Effects or Editing application).

Hardware Configuration Guidelines

In most cases, hardware integration and application installation is done on delivery by an authorized technician, and some of the procedures in this guide may not be necessary. Still, it is

a good idea to read through all chapters to familiarize yourself with the configuration procedures for the following reasons:

- Many suspected problems with your system may be due to loosened connections or improperly configured devices. This guide helps you troubleshoot problems by providing information about properly configured systems.
- If you need to call Customer Support, familiarity with this guide puts you in a better position to provide diagnostic information.
- If you want to move your system at any time, or upgrade certain hardware components, information in this guide is crucial.

Although this guide, in conjunction with the *Autodesk Stone Direct 2008 Configuration Guide*, provides complete information regarding configuring hardware components, hardware configuration should only be performed by an experienced hardware integrator familiar with the Linux operating system, HP workstations, and peripherals associated with professional high-performance video and post production of film.

Your Autodesk system consists of high-performance hardware that must be configured in an environment suited to its operational needs. Other considerations include minimizing the risk of damage due to static discharge and ensuring all components are properly grounded.

Verifying and Updating System BIOS Version

System configuration is done prior to delivery by an authorized technician, and some of the procedures in this guide may not be necessary. BIOS settings for the workstation are provided here for informational purposes.

The system BIOS on your workstation must correspond to the certified version required by your Effects or Editing application version. If the BIOS version on your system does not correspond to the table below, you must update to the certified version.

Autodesk Effect or Editing Product Version	Certified BIOS Version
2007	1.15
2007 SP3 (Extension 1)	2.13
2008 SP1	<ul style="list-style-type: none"> • 2.13, for CPUs with stepping 6F6 • 2.26, for CPUs with stepping 6FB

To determine the CPU stepping:

1. Reboot your workstation.
2. Immediately after the machine reboots, while the HP start-up screen is displayed, press **F10** to enter Setup.

3. From the File menu, select System Information.
4. On the “System Information” page, locate the “Speed / Stepping” entry in the “Processor 0” section. The line should look like the following:

```
Speed / Stepping           2600 MHz / <stepping>
```

 where <stepping> represents the CPU stepping value, for example 6F6.
5. Use the CPU stepping value with the table above to determine which BIOS version you need.
6. Return to the File menu, and select Ignore Changes and Exit.

The BIOS version currently installed on your system appears on the screen while booting the workstation. The following procedure describes how to update a Linux workstation to the certified BIOS version required by your Autodesk Effects or Editing application.

To update the BIOS on your workstation:

1. Load the DKU CD in the DVD-ROM drive on the workstation.
2. Open a terminal.
3. Type:

```
cd /mnt/cdrom/Utils/BIOS/
```

 Each platform supported by the version of your Effects or Editing application has its own directory that contains an *.iso* file.
NOTE: For more information about updating the BIOS on your workstation, refer to the README file located in your platform’s directory.
4. Type:

```
cd <platform>
```
5. Burn the *.iso* file for your platform onto a CD-ROM and place it in the DVD-ROM drive on the workstation.
6. Reboot the workstation and press **F10** to enter Setup.
7. Select a language.
8. From the File menu, select Flash System ROM.
 The Select a Drive menu appears.
9. Click Optical Drive.
 The Select a Drive confirmation menu appears.
10. Press **F10** to confirm.

11. Select the *.bin* file.

The Flash System ROM confirmation menu appears.

12. Press **F10** to confirm.

13. Press any key.

System ROM Flash was successful appears.

14. Verify system BIOS settings. See [“Verifying System BIOS Settings”](#) on page 6.

15. From the File menu, select Save Changes and Exit.

Verifying System BIOS Settings

You do not normally need to adjust these settings. BIOS settings for the workstation are provided here for informational purposes only.

To enter the system BIOS, you must press **F10** while booting the workstation.

The following table lists the proper Autodesk certified BIOS settings. Items not listed are set to their default factory settings. If there is any doubt about whether items are set to their default values, refer to [“Restoring BIOS to Default Factory Settings”](#) on page 6.

BIOS Menu	Item	Value
Storage, Storage Options	SATA Emulation	Separate IDE Controller
Storage	Boot Order	Optical Drive
		USB Device
	Boot Order, Hard Drive	Integrated SATA
		Integrated IDE
Power, OS Management	Run Time Power Management	Disabled
	Idle Power Savings	Normal
	ACPI S3 Support	Disabled
Hardware Power Management	SATA Power Management	Disabled
Advanced, Device Options	S5 Wake on LAN	Disabled

WARNING: Before installing Red Hat 4 Update 3 validate the BIOS Settings. If SATA Emulation is not correctly configured, Red Hat will have to be re-installed.

Restoring BIOS to Default Factory Settings

If there is any doubt about whether items contain factory default values, the following procedure restores default factory settings.

To restore default factory BIOS settings:

1. Press **F10** while booting the workstation to enter the system BIOS.
2. From the File menu select Default setup | Restore Factory Settings as Default.
3. Press **F10** to accept the changes.
4. Select Apply Defaults and Exit.

This restores the original factory system defaults.

Memory Requirements

The HP xw8400 uses DDR2-667 ECC Fully Buffered DIMMs. The amount of memory required for your Autodesk Effects or Editing system depends on the resolution of your projects, the type of work you perform and, in some cases, the platform on which you are running the application. Refer to the *Software Installation Guide* for your product to determine the memory requirements for your Effects or Editing application.

Ensuring Proper Environmental Conditions

You should consider the following environmental guidelines for all hardware configuration:

- Make sure the rack in which hardware components are installed is open or ventilated. Follow the ventilation specifications that apply to your system.
- Place all components in an air-conditioned environment. All hardware components generate heat and must be kept cool. See [“Power and Air Conditioning Requirements”](#) on page 7.
- Keep all hardware components in a clean, dust-free location.
- Minimize vibration and humidity.
- Do not block the vents on the component housing.
- Do not drape anything, such as a jacket or a blanket, over hardware components.
- Minimize electromagnetic noise by separating digital data and power cables from analog audio cables and running them in different cable ducts.

Power and Air Conditioning Requirements

The values for power consumption and heat output were recorded on an Autodesk certified system with all of the required peripheral and certified components.

NOTE: These values can fluctuate if uncertified hardware components or third party applications are added to your system. The use of uncertified hardware components or third party applications is not supported. Please consult the manufacturer’s documentation for standardized minimum and maximum values.

The following table summarizes the power consumed by the HP xw8400 system and the heat it generates under the maximum processing load produced by your Effects or Editing application. For detailed specifications, including noise output, see the documentation provided by the manufacturer.

Component	Quantity	Startup Amps (120V / 240V)	Max. Amps (120V / 240V)	Watts	Heat (BTUs)
HP xw8400	1	3.6 / 1.8	3.2 / 1.6	384	1310.1

You must be able to meet the startup power requirement and have a climate control system with the capacity to maintain the temperature of this component under the maximum processing load. Refer to the following table for standard conversion benchmarks and an example of how they are used to establish climate control requirements.

Unit Conversion	Example
1 Watt = 3.413 BTU	384 Watts = 1310.1 BTU
12000 BTU = 1 Ton of air conditioning	1310.1 BTU = 0.109 Ton of air conditioning

Avoiding Damage from Static Electricity

When installing any hardware equipment, take the following precautions to prevent damage to sensitive components from static discharge:

- Make sure power is turned off on the component you are working on. It is a good idea to unplug components until all other connections are configured.
- Always wear a grounded static wrist strap. Attach the strap's alligator clip to any grounded metal surface on the component's chassis that you are working on. Place the wristband around your wrist.
- Do not handle any components unnecessarily, particularly boards and cards that slide in and out of PCI slots on their parent hardware components.

Grounding Audio Hardware Components

It is important to properly ground your audio components. Otherwise, you may have ground loops, or humming in the system. To ensure audio components are properly grounded, use the XLR-3 cables shipped with your system. Using any other cables may cause humming in the system.

Receiving Your Shipment

When you receive your shipment, check all the boxes for dents or other markings that may indicate damage during transport. If you suspect a component is damaged, carefully inspect it before setting up the system. If you receive a damaged component, call Customer Support.

Use the enclosed packing checklist to ensure you received all parts.

Notation Conventions

A number of style conventions are used throughout this guide. These conventions and examples of their use are shown as follows.

Convention	Example
Text that you enter in a command line or shell appears in Courier bold. You must press the Enter key after each command.	rpm -qa
Variable names appear in Courier, enclosed in angle brackets.	<filename>
Variables that appear enclosed in square brackets are optional.	[<filename>]
Feedback from the command line or shell appears in Courier.	limit coredumpsize
Directory names, filenames, URLs, and command line utilities appear in italics.	<i>/usr/discreet</i>

Contacting Customer Support

You can contact Autodesk Media and Entertainment Customer Support at www.autodesk.com/support or in one of the following ways.

Location:	Contact Information:
Within the Americas:	Hotline (North America): 1-800-925-6442 Direct dial: 415-507-5256 (Country code = 1) 8 AM to 8 PM EST Monday to Friday, excluding holidays <i>me.support@autodesk.com</i>
Within Europe, Middle-East and Africa:	Hotline (from London, UK): +44-207-851-8080 9 AM to 5:30 PM (local time) Monday to Friday, excluding holidays <i>me.emea.support@autodesk.com</i>
Within Asia Pacific: (Excluding India, China, Australia, New Zealand and Japan)	Hotline (from Singapore): +65-6555-0399 9 AM to 6 PM (local time) Monday to Friday, excluding holidays <i>me.support.singapore@autodesk.com</i>
Within India:	Hotline (from Mumbai): +91-22-6695-2244 9:30 AM to 6:30 PM (local time) Monday to Friday, excluding holidays <i>me.support.india@autodesk.com</i>

Location:	Contact Information:
Within Japan:	Hotline (from Tokyo): 0120-107-290 Direct dial: +81-3-6221-1810 10 AM to 6 PM (local time) Monday to Friday, excluding holidays <i>med-sys-support-jp@autodesk.com</i>
Within China:	Direct dial: +86-10-6505-6848 9 AM to 6 PM (local time) Monday to Friday, excluding holidays <i>me.support.china@autodesk.com</i>
Within Australia and New Zealand:	Hotline (from Melbourne): +1-300-36-8355 Direct dial: +61-3-9876-8355 8 AM to 6 PM AEST Monday to Friday, excluding holidays <i>me.support.anz@autodesk.com</i>

Customer support is also available through your Autodesk reseller. To find a reseller near you, consult the reseller look-up database on the Autodesk Web site at www.autodesk.com/resellers.

Connecting Peripherals



Summary

Peripherals Connection Diagrams	11
Connecting the Keyboard, Mouse, and Tablet	14
Network Connections	14
Connecting Storage	15

Peripherals Connection Diagrams

You must connect all hardware peripheral devices before you boot your workstation. The following diagrams identify the ports to which the peripherals connect on HP xw8400 workstations in an HD or 2K (2 dual-core CPU) configuration and SD (1 dual-core CPU) configuration.

All diagrams contain a Gigabit Ethernet (GigE) network adapter located in PCI slot five. Your workstation may be configured with an optional QuickSilver InfiniSERV 7000 adapter that replaces the GigE adapter. On the HP xw8400 workstation the PCI slots are numbered one to seven from top to bottom.

For detailed information on video connections, refer to [Chapter 3, “Video Hardware Components.”](#) on page 17.

For detailed information on audio connections, refer to [Chapter 4, “Setting Up Audio Hardware.”](#) on page 33.

HP xw8400 Workstation HD or 2K Configuration

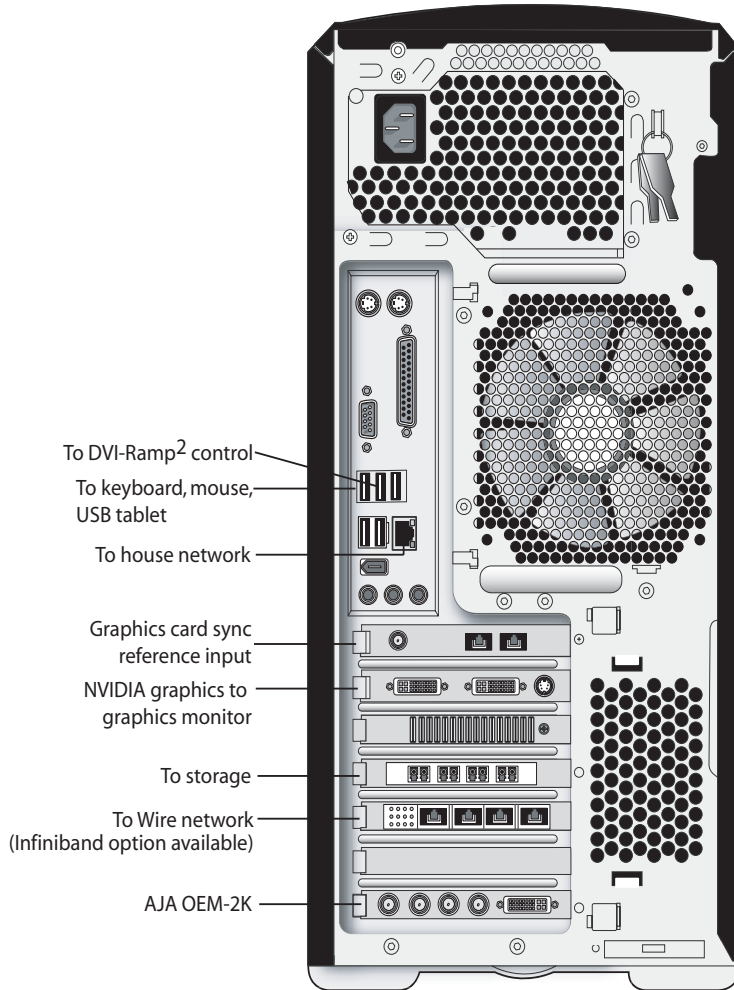

HP xw8400 Workstation SD Configuration

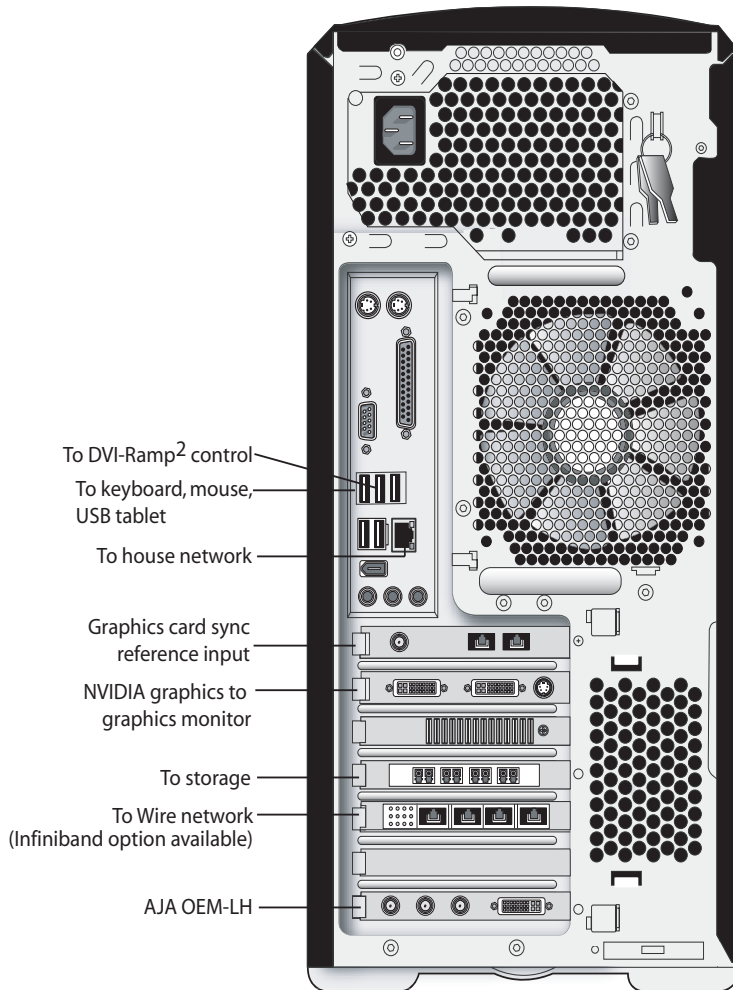

Connecting the Keyboard, Mouse, and Tablet

Connect the keyboard, mouse, and tablet to the USB extender and the Linux workstation *before* booting the workstation and before installing the application.

The Wacom® Intuos USB tablet is shipped with your system. All customization with respect to the tablet, including setting tablet margins, should be done in the Preferences menu of your application. For help, see the description of Pointer preferences in the *User's Guide* for your application.

Network Connections

Consult the [“Peripherals Connection Diagrams”](#) on page 11 as a reference for network interface card (NIC) locations.

Connecting to Gigabit Ethernet (GigE) Networks

You must use the correct Gigabit Ethernet network card to connect your Linux workstation to the Wire network. Otherwise, you may degrade the performance of your Wire network.

Do the following to maximize Wire network performance in your facility:

- Connect ports from the add-on network card to the switch used for your Wire network.
- Connect the house network to the on-board network port shown in [“Peripherals Connection Diagrams”](#) on page 11. Do not use any of the ports on the add-on network card for your house network. If the house network is not connected to the on-board network port, consult your system administrator to reconfigure it.
- Use high-quality Category 6 (Cat 6) network cables when connecting the Linux workstation to your Wire network switch.

Connecting to the Infiniband (IB) Network

Your Linux workstation may be configured with an optional QuickSilver InfiniSERV 7000 adapter. The IB network adapter resides in PCI slot five. On the HP xw8400 workstation the PCI slots are numbered one to seven from top to bottom. Consult the [“Peripherals Connection Diagrams”](#) on page 11 as a reference for the optional IB network adapter location.

You must use the correct port on the IB network adapter to connect your Linux workstation to the IB Network.

To connect the workstation to an IB network:

- Connect port 1 of the IB network adapter to the IB network. On the HP xw8400 workstation Port 1 is the right port. For information on how to configure the IB adapter, refer to the *Stone and Wire Filesystem and Networking Guide*.

Connecting Storage

You can connect your Linux workstation to two types of storage:

- One or more, Stone Direct disk arrays that provide storage to individual workstations. Refer to the *Autodesk Stone Direct 2008 Configuration Guide* for information on connecting disk arrays to your workstation.
- A storage-area network (SAN) that provides shared storage for multiple workstations. For information on connecting your workstation to a SAN, refer to the *Autodesk Stone Shared Installation and Configuration Guide*.

Consult the Autodesk Web site at www.autodesk.com/discreet-documentation for the latest version of these guides.

WARNING: The Stone filesystem on 64-bit Linux has an 8-terabyte filesystem limit for SD and HD configurations, and a 13-terabyte limit for FILM configurations with an inode ratio of 3072 or higher. When configuring your storage, make sure that each partition does not exceed these limits, and that inodes are correctly configured. Refer to the *Stone and Wire Filesystem and Networking Guide*.

Connecting and Configuring the ATTO Fibre Channel Adapter

Your Linux workstation is configured with a 4-port ATTO Celerity FC-44ES fibre channel adapter. The fibre channel adapter resides in PCI slot four. On the HP xw8400 workstation the PCI slots are numbered one to seven from top to bottom. Consult the [“Peripherals Connection Diagrams”](#) on page 11 as a reference for the ATTO fibre channel adapter location.

Connect all 4 ports to Stone Direct storage, or if you have both types of storage, connect the two inner ports to Stone Direct storage and the two outer ports to a SAN or archiving device.

3

Setting Up Video Hardware

Summary

Video Hardware Components	17
Wiring Your HP xw8400 in a 2K or HD Configuration	18
Wiring Your HP xw8400 in an SD Configuration	20
Standard VTR Control Cable	23
Setting Up VTR Emulation	23
Updating AJA OEM-2K PCI-X Firmware	27
Miranda DVI-Ramp Firmware Update	29

Video Hardware Components

You use the video components to set up video I/O and a broadcast monitor. The only video hardware you must provide are a sync generator, a VTR, and a HD/SDI broadcast monitor. The following components are included in your hardware shipment.

AJA OEM-2K board and Breakout Box (HD and 2K configurations) — The AJA OEM-2K board and breakout box provides video I/O, audio, and VTR control. The AJA breakout box connects to the AJA OEM-2K board and handles SD (NTSC, PAL) and HD at a depth of 8 and 10 bits.

AJA OEM-LH board and Breakout Cable (SD configurations) — The AJA OEM-LH board provides video I/O, audio, and VTR control. The AJA breakout cable connects to the AJA OEM-LH board and handles SD (NTSC, PAL) resolutions at a depth of 8 and 10 bits.

NVIDIA® Quadro® FX 5500G graphics board — The NVIDIA Quadro FX 5500G is the graphics board for 2K configurations. The Quadro FX 5500G, in collaboration with the Miranda DVI-Ramp², provides output to your computer monitor and to the broadcast monitor.

NVIDIA Quadro FX 4500G graphics board — The NVIDIA Quadro FX 4500G is the graphics board for HD and SD configurations. The Quadro FX 4500G, in collaboration with the Miranda DVI-Ramp², provides output to your computer monitor and to the broadcast

monitor. In SD configurations that do not contain the optional Miranda DVI-Ramp², the Quadro FX4500G only provides output to your computer monitor. The AJA OEM-LH board provides output to the broadcast monitor.

LCD graphics monitor — The LCD graphics monitor features a wide screen that makes a 16:9 aspect ratio possible for HD projects. With this monitor, the application runs at a maximum resolution of 1920x1200.

Miranda DVI-Ramp² (optional in SD configurations) — The DVI-Ramp² connects the Linux workstation to two display devices: a high-resolution computer monitor and a broadcast monitor. This allows the application user interface to be displayed on a standard, non-interlaced, high-resolution computer monitor, while the portion of the user interface containing video content (preview window) is extracted and output on a broadcast video monitor. The DVI-Ramp² can output either a standard definition serial digital video signal or a high definition serial digital video signal. It provides a real-time preview to both the graphics display and broadcast monitor.

Altinex® DA1804NT video distribution amplifier — The Altinex video distribution amplifier can serve up to four video hardware devices from a single sync source/generator. It serves the sync signal to the NVIDIA graphics board, the AJA OEM-2K or AJA OEM-LH board, and the Miranda DVI-Ramp².

Wiring Your HP xw8400 in a 2K or HD Configuration

Consult the following diagrams to connect an HP xw8400 workstation equipped with an AJA OEM-2K board and Miranda DVI-Ramp² for 2K or HD video I/O.

Note the following about the wiring diagrams:

- The graphics board for the 2K configuration is an NVIDIA Quadro FX 5500G, while in the HD and SD configurations, the graphics board is an NVIDIA Quadro FX 4500G.
- Do not use an SD (NTSC or PAL) sync generator for HD projects. Always use a tri-level sync generator for HD projects. Using the wrong sync generator for a project may impact the stability of your workstation.
- The sync source is connected to the Altinex distribution amplifier. It is critical to connect the Altinex distribution amplifier exactly as shown in the diagram to ensure the sync works correctly.
- The VTR is connected to the SDI In A and SDI Out A ports of the AJA breakout box. You can use the SDI In B and SDI Out B ports for dual link video I/O.
- VTR control is provided through the RS-422 port on the AJA breakout box.

HD and 2K Configuration

Consult the following diagram to connect an HP xw8400 workstation equipped with an AJA OEM-2K board, NVIDIA Quadro FX 5500G and a Miranda DVI-Ramp² for HD or 2K video I/O.

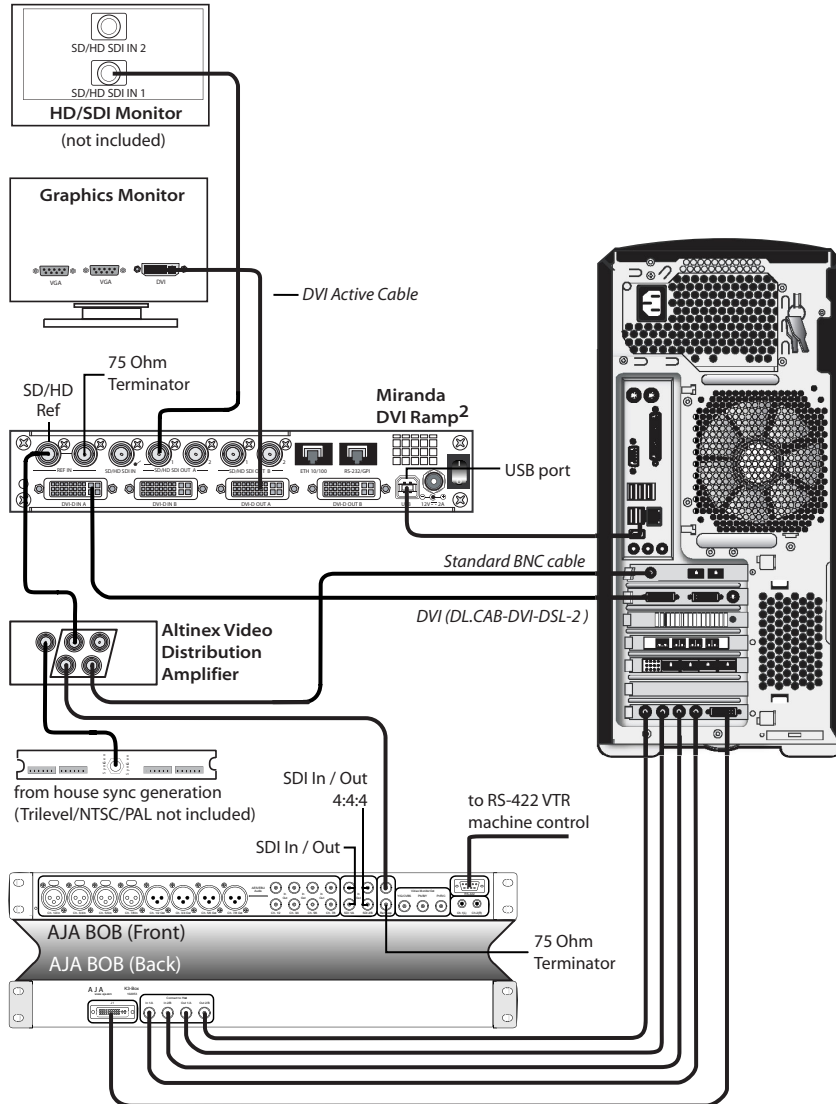

Wiring Your HP xw8400 in an SD Configuration

Use this section to connect an HP xw8400 workstation equipped with an AJA OEM-LH board and optional Miranda DVI-Ramp² for SD video I/O. Refer to the following diagrams for wiring instructions for this configuration.

Note the following about the wiring diagrams:

- The sync source is connected to the Altinex distribution amplifier. It is critical to connect the Altinex distribution amplifier exactly as shown in the diagram to ensure the sync works correctly.
- The VTR is connected to the SDI In and SDI Out 1 ports of the AJA OEM-LH board.
- VTR control is provided through the RS-422 connection on the AJA breakout cable.

SD Configuration

Consult the following diagram to connect an HP xw8400 workstation equipped with an AJA OEM-LH board, Miranda DVI-Ramp2 and NVIDIA Quadro FX4500G graphics board for SD video I/O.

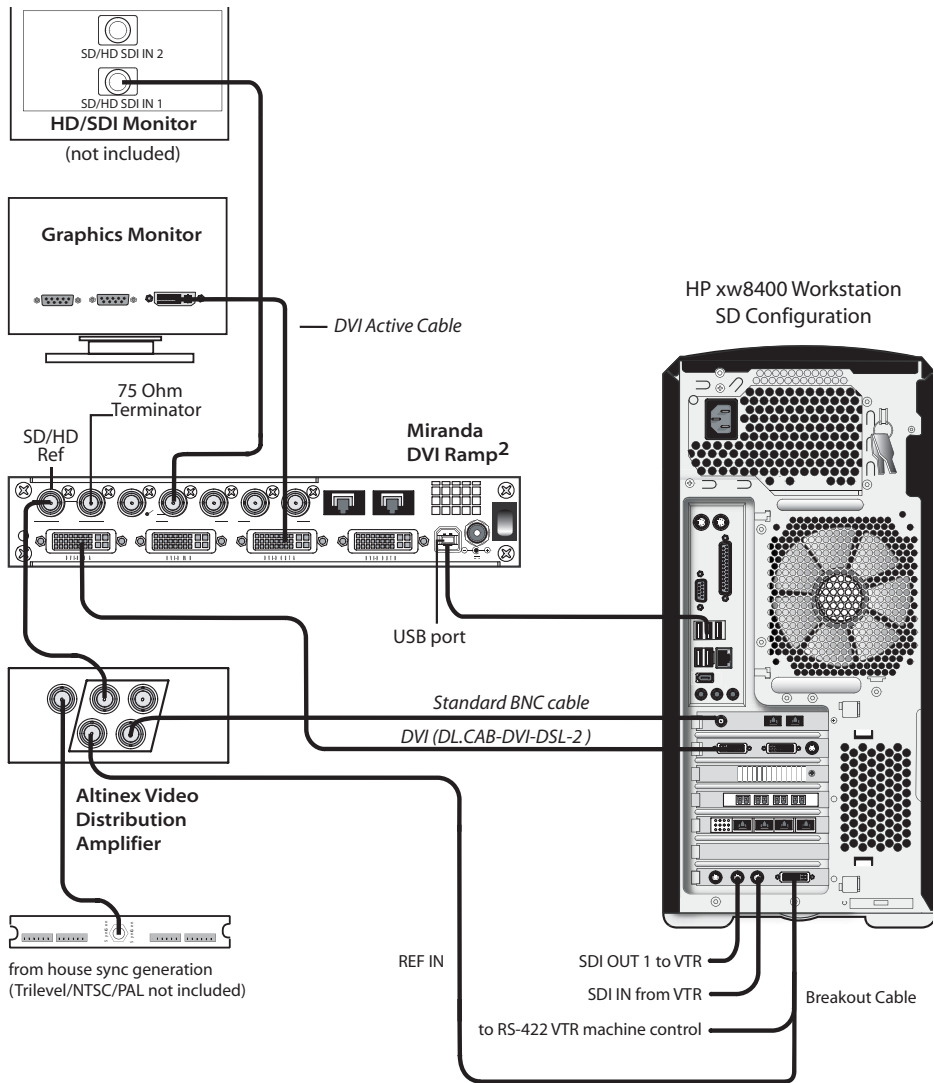

SD Configuration Without DVI-Ramp

Consult the following diagram to connect an HP xw8400 workstation equipped with an AJA OEM-LH board and NVIDIA Quadro FX4500G graphics board without a Miranda DVI-Ramp² for SD video I/O.

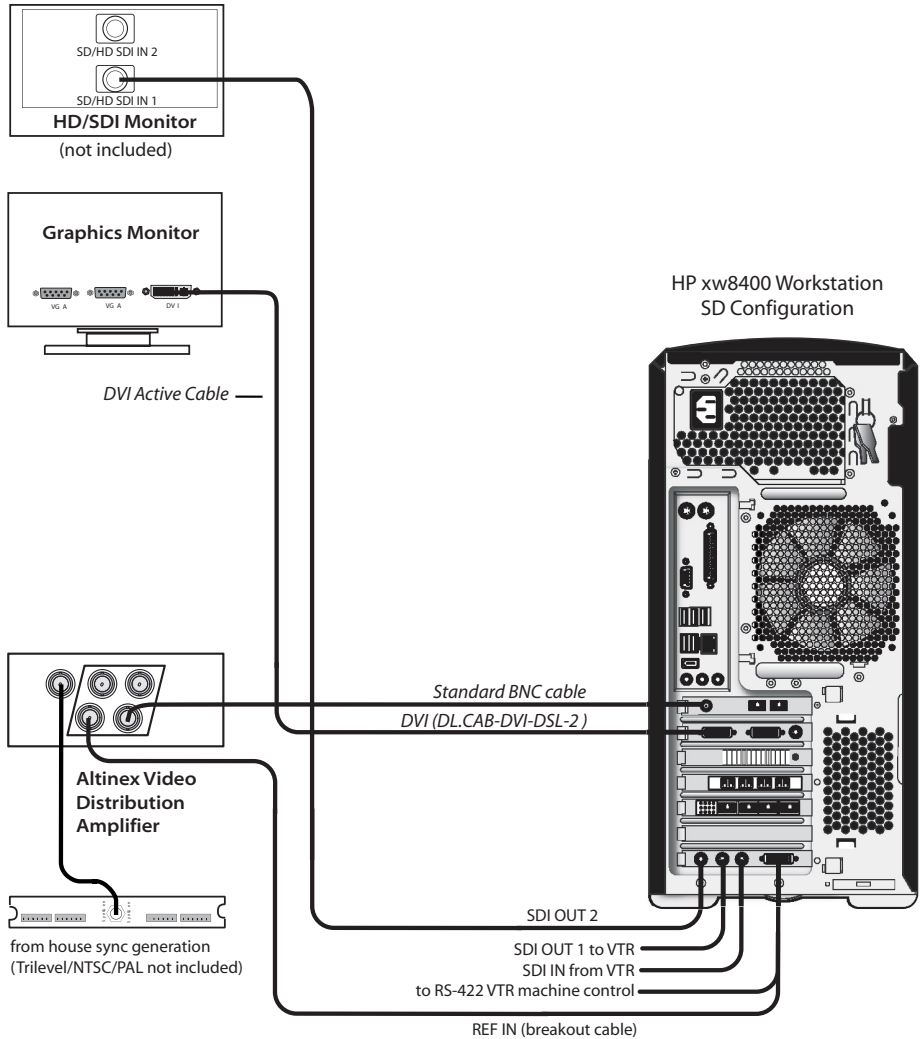

NOTE: In read back preview mode (configuration without a DVI-Ramp²) the broadcast monitor will display black when only audio is output to VTR.

Standard VTR Control Cable

The following diagram depicts the RS-422 control cable pinouts for the standard VTR control cable.

Standard VTR Control Cable:
Linux/AJA Controlling VTR (Normal Video I/O Control Cable)

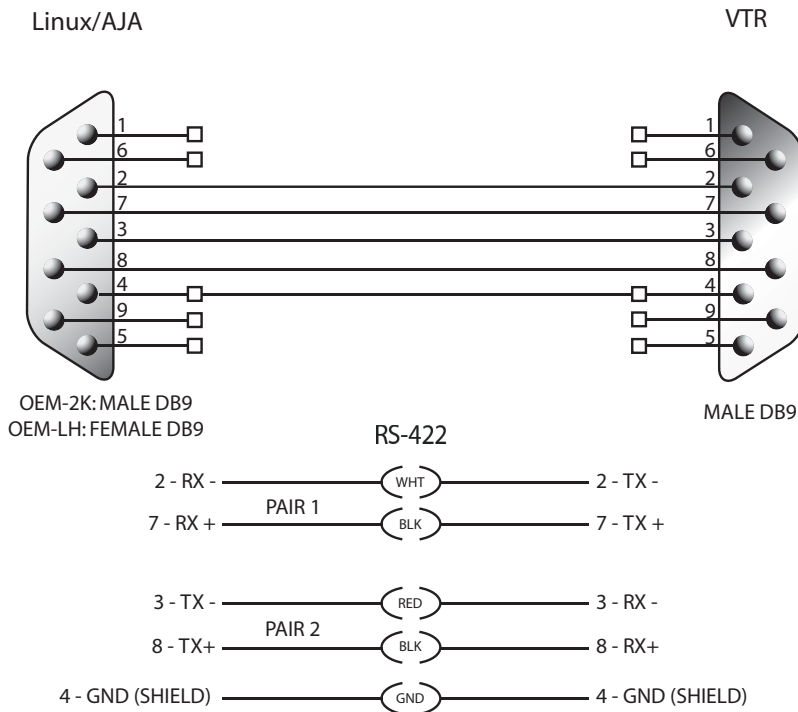

Setting Up VTR Emulation

You can configure your Editing application to emulate a VTR for both input and output in real time. You control the emulator from the application or device that sees the Editing application as a VTR.

The following procedure describes how to configure the hardware for VTR emulation. Consult the “*VTR Emulation*” chapter in the *User’s Guide* for your Editing application for more information.

To configure hardware for VTR emulation:

1. Connect the video I/O cables between the devices involved in the VTR emulation process (out-to-in/in-to-out). Make sure the connections support the video standard you want to work with.

If you intend to use the emulator as a Player, it is recommended that you connect one black or colour bar SDI signal to the input of the system serving as the VTR emulator. This ensures the Player is stable and correctly synced.

NOTE: VTR emulation requires an Editing workstation with a video board. The Video keyword for the corresponding device must be uncommented in the software initialisation configuration file. See the description of the Video keyword in the *Configuration File Reference Guide for Linux Workstations* for your release.

2. Connect the audio I/O cables between the devices involved in the VTR emulation process (out-to-in/in-to-out).

If you intend to use the emulator as a Player, it is recommended that you connect an external AES signal such as a tone to the input of the system serving as the VTR emulator. This ensures the Player is stable and correctly synced.

NOTE: Connect an RS-422 control cable to the serial ports between the devices in the VTR emulation process. Make sure the serial ports correspond to those defined by the Emulator keywords in the software initialisation configuration file, *init.cfg*. See the description of the Emulator keyword in the *Configuration File Reference Guide for Linux Workstations* for your release.

NOTE: The RS-422 cables for VTR emulation require custom pinouts. See [“VTR Emulation RS-422 Control Cables”](#) on page 24.

3. Make sure the appropriate video and audio sync setup is in place.

VTR Emulation RS-422 Control Cables

Custom cables are required to control the VTR emulator. The pinouts required by the cable depend on the workstation and device involved in the VTR emulation process. The following diagrams depict the control cable pinouts required for the most common VTR emulation setups.

VTR-Emulation Control Cable: Linux/AJA Master Controlling Linux/AJA Emulator

Linux/AJA Master

Linux/AJA Emulator

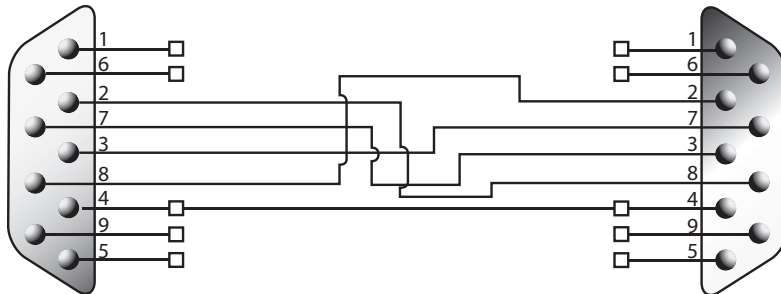

OEM-2K: MALE DB9
OEM-LH: FEMALE DB9

OEM-2K: MALE DB9
OEM-LH: FEMALE DB9

RS-422

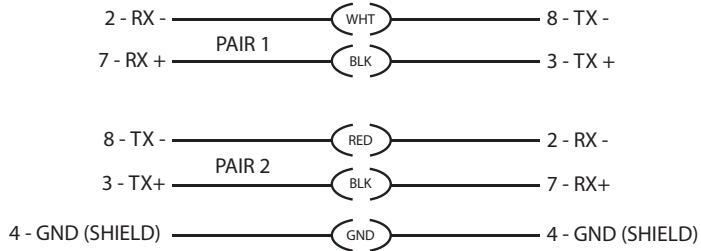

VTR-Emulation Control Cable:
 SGI Master Controlling Linux/AJA Emulator
 Linux/AJA Master Controlling SGI Emulator

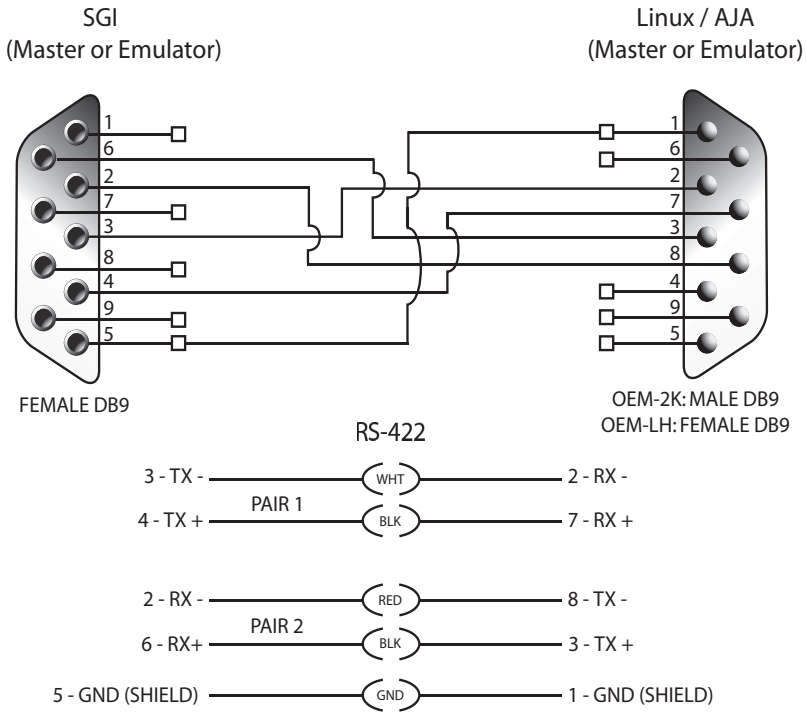

VTR-Emulation Control Cable: 3rd-Party Device Master Controlling Linux/AJA Emulator

3rd-Party Device Master

Linux/AJA Emulator

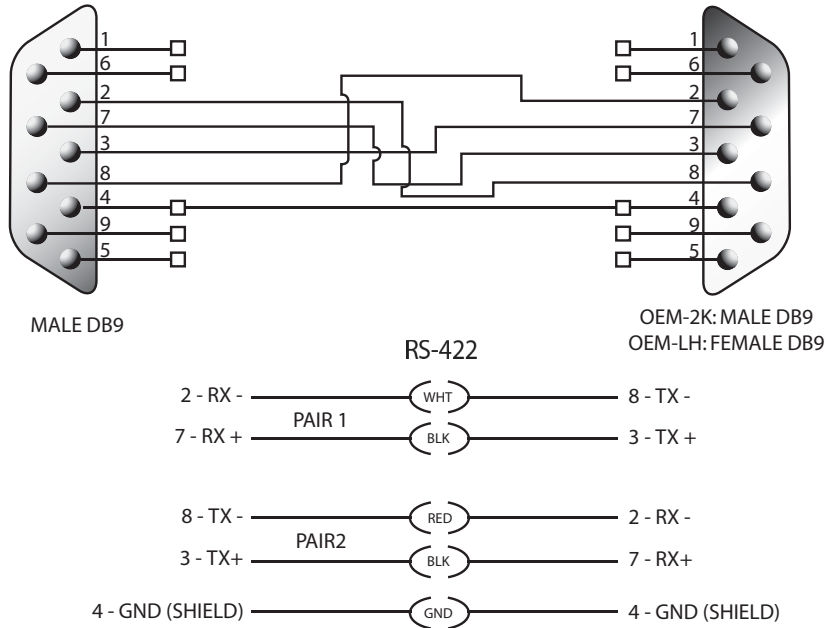

Updating AJA OEM-2K PCI-X Firmware

System configuration is done prior to delivery by an authorized technician, and some of the procedures in this guide may not be necessary. The update procedures are provided here for informational purposes.

Your workstation's AJA OEM-2K board must contain the certified PCI-X firmware required by the version of your Effects or Editing application. If the PCI-X firmware version on your AJA OEM-2K board does not correspond to the table below, you must update to the certified version.

Autodesk Effect or Editing Product Version	Certified PCI-X Firmware Version
2007 SP1	0x39
2007 SP2	0x50

Autodesk Effect or Editing Product Version	Certified PCI-X Firmware Version
2008	0x50
2008 SP1	0x55

Verifying the Current PCI-X Firmware Version

The following procedure describes how to verify the AJA OEM-2K board's PCI-X firmware version.

To verify AJA OEM-2K PCI-X firmware version:

- Make sure the driver is loaded by typing:

```
cat /proc/driver/aja
```

The following output should appear:

```
AJA Driver Name: oem2k
Version: 4.1 Beta 11

Card #: 0
Board Version String: OEM 2K - Rev 0
PCI Version: 0x55
Board ID: 10196500
FPGA built on 2007/09/18 at 10:57:41
```

NOTE: If there is no *aja* file in */proc/driver*, you are using an outdated driver or the driver is not loaded and you must install the latest DKU for your workstation. Refer to the *Autodesk Effects and Editing 2008 Software Installation Guide for Linux Workstations*.

Updating PCI-X Firmware

The following procedure describes how to update the AJA OEM-2K board's PCI-X firmware to the certified version required by your Autodesk Effects or Editing application.

To update AJA OEM-2K PCI-X firmware:

1. Log in as root and open a terminal.
2. Insert the DKU CD in the CD-ROM drive.
3. Mount the CD-ROM by typing:

```
mount /mnt/cdrom
```

NOTE: If your workstation has multiple CD-ROM drives, the drive containing the DKU CD may not be mapped as */mnt/cdrom*. You can use any mapped CD-ROM drive for this procedure by using the appropriate mount point for the CD-ROM drive in your workstation in these steps.

4. Go to the *AJA_firmwareUpdate* directory on the DKU CD. Type:
`cd /mnt/cdrom/Utils/AJA_firmwareUpdate`
5. Run the *AJAfw_update* utility to scan the AJA current firmware and, if required, to update to the latest firmware version. Type:
`./AJAfw_update`

The script checks the firmware of your AJA board and one of the following events occurs:

- The script detects that the firmware and drivers need to be updated and prompts you to start the update. In this case, continue to the next step of this procedure.
- The script indicates that the firmware is up-to-date and exits. In this case, you are done; go to step 7 of this procedure to eject the DKU CD.

NOTE: For more details about the AJA firmware procedures, you can consult the *README* file located in the current directory.

6. Start the firmware update by typing **Y** and then pressing **ENTER**.
 While the AJA board's firmware and drivers are being updated, your workstation appears to be frozen and your mouse and keyboard do not work. This is normal and indicates that the firmware is being updated. Once the firmware update is complete, you are returned to the terminal.
7. When you are returned to the terminal, return to the root directory and eject the DKU CD from the CD-ROM drive by typing the following commands:
`cd /`
`eject /mnt/cdrom`
8. Shut down your Linux workstation by typing:
`shutdown -g0`
 If your workstation does not prompt you to power down, press the power button for 10 seconds to force a power down.
9. Disconnect the power cord.
10. Wait 10 seconds, reconnect the power cord, and then restart your workstation normally.

Miranda DVI-Ramp Firmware Update

If you are upgrading from a previous version of an Effects or Editing application, you may need to update your DVI-Ramp firmware, depending on the hardware version of your DVI-Ramp unit. The DVI-Ramp firmware update utilities required to check your firmware version and

perform the update are included with the DKU version associated with the release of your Effects or Editing application.

The firmware on your DVI-Ramp must correspond to the certified version required by your Effects or Editing application version. Each firmware in itself is associated to a hardware version. If the firmware on your DVI-Ramp does not match its hardware version listed in the table below, you must update the firmware to the certified version.

Effects or Editing Product Version	Hardware Version	Certified Firmware Version
2008 SP1 with	DVI-Ramp	3.70
	DVI-Ramp	4.71
	DVI-Ramp ²	6.0506 6.0507 6.0508

The DVI-Ramp firmware update utilities required to check your firmware version and perform the update are included with the DKU version associated with the release of your Effects or Editing application. The following procedure describes how to verify the firmware version of the DVI-Ramp.

To check if a DVI-Ramp firmware update is needed:

- With the DVI-Ramp connected to your workstation and powered up, log in as root and open a terminal.

WARNING: If your DVI-Ramp unit is connected to the HP workstation using a USB-to-Serial adapter, you must remove the adapter from the USB port, and connect the serial cable of the DVI-Ramp to the serial port of the workstation. This does not apply to DVI-Ramp² units.

1. Insert the DKU CD in the CD-ROM drive.
2. Mount the CD-ROM by typing:

```
mount /mnt/cdrom
```

NOTE: If your workstation has multiple CD-ROM drives, the drive containing the DKU CD may not be mapped as `/mnt/cdrom`. You can use any mapped CD-ROM drive for this procedure by using the appropriate mount point for the CD-ROM drive in your workstation in these steps.

3. Go to the `DVI_firmwareUpdate` directory by typing:

```
cd /mnt/cdrom/Utils/DVI_firmwareUpdate
```

4. Run the `info` command to scan the DVI-Ramp's current firmware. Type:

```
./info
```

The output is similar to the following:

```

Versions:
Hardware = <Hardware Version>
Micro = <Firmware version>
Genlock = 3.21
DVI = 4.01
FrameBuffer = 4.05
SDI = 4.10

```

Where `<Hardware Version>` is the current version of the DVI-Ramp hardware, and `<Firmware version>` is the firmware currently loaded in the DVI ramp. If the firmware version does not match the hardware version listed in the table that precedes this procedure, you must perform the firmware update procedure.

To update the DVI-Ramp I firmware and software drivers:

1. Go to the `DVI_firmwareUpdate` directory by typing:
`cd /mnt/cdrom/Utils/DVI_firmwareUpdate`
2. Launch the DVI-Ramp upgrade utility by typing:
`./updateDVI`

The script checks the hardware version of the DVI-Ramp and then installs the firmware update. The update should take between 5 and 10 minutes. You can monitor the progress of the firmware update in the terminal.

The DVI-Ramp is rebooted several times during the firmware update. Any monitors connected directly to the DVI-Ramp (such as the graphics monitor and/or a broadcast monitor) will flash each time the DVI-Ramp is rebooted. This is normal and indicates that the firmware is being updated.

3. Once the firmware update is complete, updated hardware information for your DVI-Ramp appears in the terminal.
4. If you had to remove the USB-to-Serial adapter, reconnect the serial cable to the adapter, then put the adapter back in the USB port. Restart the HP workstation.

4

Setting Up Audio Hardware

Summary

- [About Audio](#) 33
- [Audio Wiring Workflow](#) 33
- [Audio Hardware Components](#) 34
- [Understanding Remote vs. Local Control of the Lucid Converter](#) 35
- [Wiring Audio Hardware in a 2K or HD Configuration](#) 35
- [Wiring Audio Hardware in an SD Configuration](#) 37
- [Configuring the Lucid ADA 88192 Converter](#) 38
- [Audio Keywords in the Software Initialisation Configuration File](#) 40

About Audio

Your application uses the Discreet Native Audio subsystem. Discreet Native Audio offers the following features. All channels use 24-bit audio resolution.

Configuration	Features
SD	2 audio input channels (AES XLR and analog) 2 audio output channels (AES XLR and analog) or 8 audio input channels (embedded) 8 audio output channels (embedded)
2K and HD	8 audio input channels (embedded, AES XLR, and analog) 8 audio output channels (embedded, AES XLR, and analog)

Audio Wiring Workflow

The following procedure provides the general workflow for setting up the audio subsystem of your Effects or Editing application.

To wire the audio subsystem:

1. Ensure that all of your workstation peripherals and video hardware components are properly connected. If necessary, refer to [Chapter 2, “Connecting Peripherals.”](#) on page 11 and [Chapter 3, “Setting Up Video Hardware.”](#) on page 17.
2. Verify that you have all the required audio hardware components. See [“Audio Hardware Components”](#) on page 34.
3. Determine whether you want to control the Lucid converter remotely or locally (2K or HD configurations). This affects the way you wire the audio hardware. See [“Understanding Remote vs. Local Control of the Lucid Converter”](#) on page 35.
4. Connect your audio hardware devices. To avoid system instability, make sure you connect your audio hardware as illustrated for your configuration:
 - For a 2K or HD configuration, see [“Wiring Audio Hardware in a 2K or HD Configuration”](#) on page 35.
 - For an SD configuration, see [“Wiring Audio Hardware in an SD Configuration”](#) on page 37.
5. Configure the Lucid converter for remote or local control (2K or HD configurations). See [“Configuring the Lucid ADA 88192 Converter”](#) on page 38.
6. Set the appropriate keywords in the software initialization file. See [“Audio Keywords in the Software Initialisation Configuration File”](#) on page 40.

Audio Hardware Components

Discreet Native Audio uses the following hardware components, shipped with your system.

Lucid Converter ADA 88192 (2K or HD configurations) — Converts signals between the Linux workstation and all digital or analog audio I/O devices.

AJA Balanced Audio Breakout Box and AJA OEM-2K Board (2K or HD Configurations) — The Balanced Audio breakout box is the audio component of the AJA Breakout Box. It provides connections for audio I/O. This breakout box connects to the AJA OEM-2K board on your workstation. The OEM-2K board provides real-time input and output of uncompressed SD and HD video signals as well as audio data at 24-bit resolution. The OEM-2K board handles balanced AES/EBU audio signals from the Balanced Audio breakout box.

AJA Breakout Cable and AJA OEM-LH Board (SD configurations) — The AJA breakout cable provides real-time input and output of uncompressed SD video signals, as well as audio data at 24-bit resolution.

Understanding Remote vs. Local Control of the Lucid Converter

In a 2K or HD configuration, you can control the converter either remotely or locally. Remote control of the converter means that you adjust converter settings through the audio preferences of the application. If you want to control the converter remotely, you must connect the converter to the serial port of the HP xw8400 workstation. Local control means you adjust converter settings manually, using the controls on the front of the converter. Controlling the converter remotely is the recommended method as it does not require physical access to the converter to change settings.

Whether you control the converter remotely or locally, you should take any necessary precautions to prevent inadvertent adjustments to settings via the controls on the front of the converter. For example, if the converter is one of several in a machine room, you might label each with the name of the computer to which it is connected, along with whether control is local or remote.

Wiring Audio Hardware in a 2K or HD Configuration

Consult the following diagrams to connect the Lucid ADA 88192 converter to the AJA breakout box in a 2K or HD configuration.

2K or HD Configuration

Consult the following diagram to connect the Lucid ADA 88192 converter to the AJA breakout box in a 2K or HD configuration.

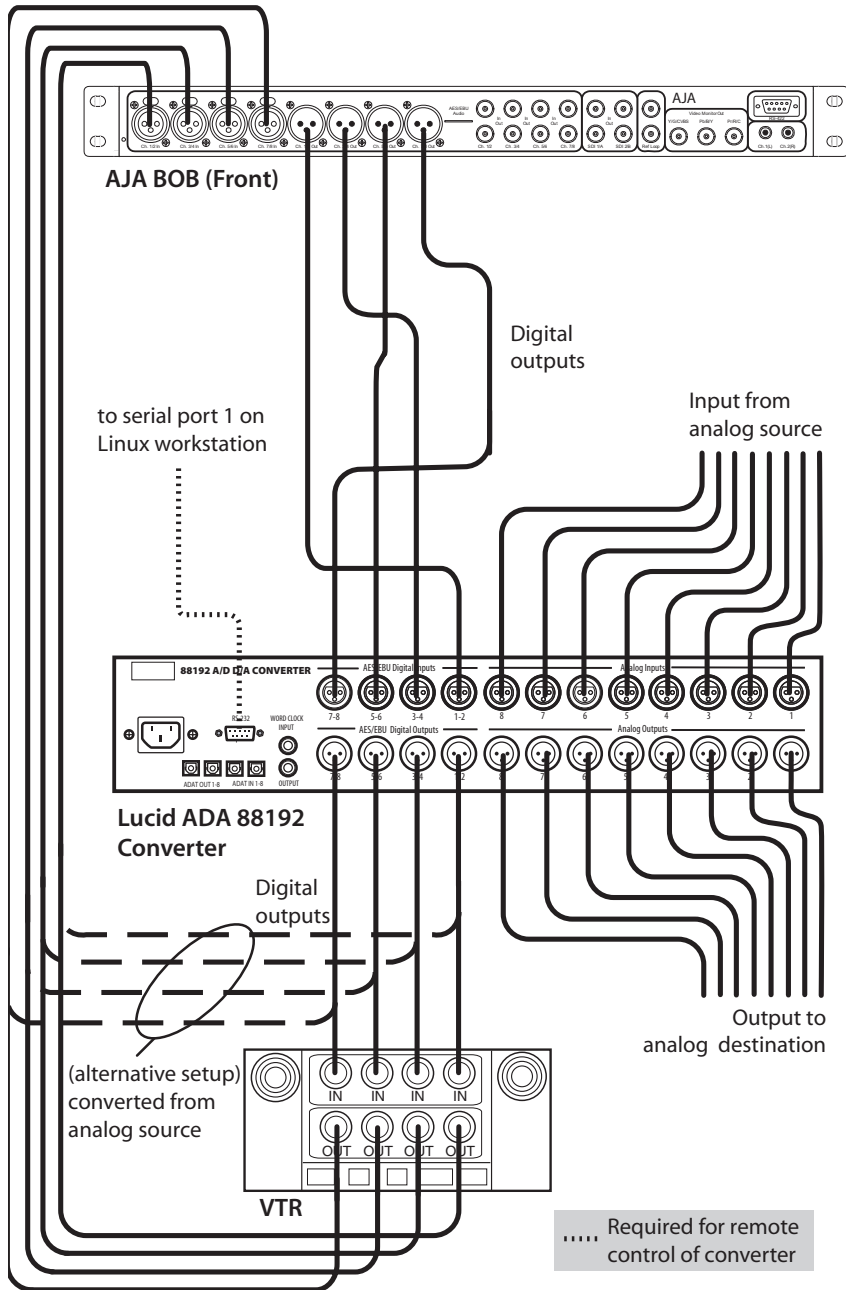

Wiring Audio Hardware in an SD Configuration

To connect the Discreet Native Audio hardware components to the AJA breakout cable in an SD configuration, refer to the following diagram.

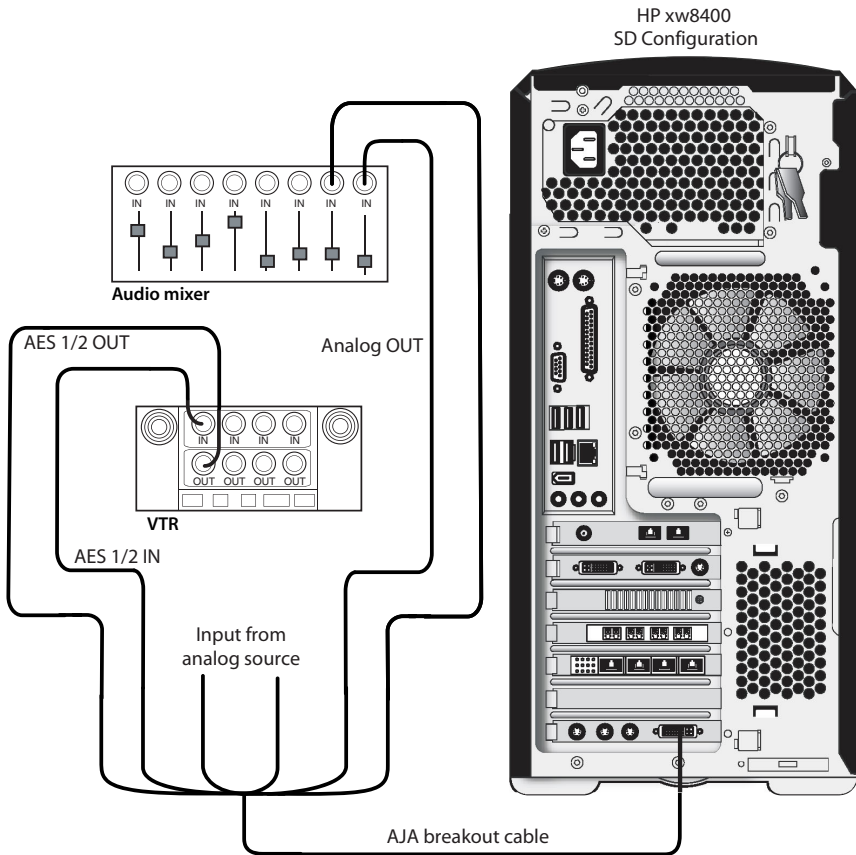

Configuring the Lucid ADA 88192 Converter

You must manually configure the Lucid converter for either remote or local control. This section describes how to use the controls on the front of the converter to adjust settings, and lists the proper settings for remote control and for local control.

Adjusting Lucid ADA 88192 Converter Settings

You configure the converter through a series of setup menus that appear in the display on the front of the converter. Use the encoder dial and button immediately to the right of the display to navigate these menus and adjust settings.

The top level setup menu contains the following menu items: ADAT, AES, Analog, Meter, Route, Sync, and System. Each of these menu items takes you into a submenu, from which you can select and adjust settings.

The procedures below provide basic information on navigating and adjusting settings. If you require additional information, refer to the Lucid ADA 88192 manual included with your shipment.

To navigate menus and adjust settings:

- Use the encoder dial and the button as follows:

To:	Do this:
Select a menu option	Rotate the dial to highlight the option, then press the dial to select that option. If the option you select has choices (as for example in the Route menu), rotate the dial again to move through the choices, and press the dial to select an option.
Back up one level in the menu tree	Press the button.
Navigate to the top level setup menu	Press the button. Repeat until you are in the top level setup menu.

To reset all settings to their factory defaults:

1. In the top level setup menu, select System, then select Miscellany.
2. In the Miscellany menu, select Defaults: RESET.

All settings are reset to their factory defaults.

NOTE: The factory default for the items in the AES setup menu is SRC ON. Both local and remote control require these items to be set to SRC OFF. If you reset to defaults, be sure to manually set these items back to OFF (you cannot adjust these settings remotely).

Lucid ADA 88192 Converter Settings for Remote Control

You must configure the following settings to control the converter remotely. Any setting not listed here either has no effect with the application or can be set through the audio preferences of the application.

Menu	Menu Item	Comment
ADAT	ADAT INs: SRC ON ADAT INs: SMUX OFF	
AES	AES IN1+2: SRC OFF AES IN3+4: SRC OFF AES IN5+6: SRC OFF AES IN7+8: SRC OFF	
Analog Analog INs: SoftClip	IN1+2: SoftClip OFF IN3+4: SoftClip OFF IN5+6: SoftClip OFF IN7+8: SoftClip OFF	
Meter	Clip Detect: 3	3 is the recommended setting
System Miscellany	Route Unit: 8	8 is the recommended setting

Lucid ADA 88192 Converter Settings for Local Control

You must configure the following settings to control the converter locally. Any setting not listed here either has no effect with the application or can be set to any of the values available for it.

Menu	Menu Item	Comment
ADAT	ADAT INs: SRC ON ADAT INs: SMUX OFF	
AES	AES IN1+2: SRC OFF AES IN3+4: SRC OFF AES IN5+6: SRC OFF AES IN7+8: SRC OFF	
Analog Analog INs: SoftClip	IN1+2: SoftClip ON IN3+4: SoftClip ON IN5+6: SoftClip ON IN7+8: SoftClip ON	
Analog Analog INs: Gain	set each input channel to a value in the range -95.5 to +31.5 dB	
Analog Analog OUTs: Level	set either -10 or +4 for each output channel	
Meter	Clip Detect: 3	3 is the recommended setting

Menu	Menu Item	Comment
Route	For analog audio: AES INs --> ADAT OUTs Analog INs --> AES OUTs AES INs --> Analog OUTs	If these options do not appear, verify that Route Unit (in the System, Miscellany menu) is set to 8.
	For digital audio: AES INs --> ADAT OUTs AES INs --> AES OUTs AES INs --> ANALOG OUT	
Sync	Internal OFF External AES 1+2	External AES 1+2 is the recommended setting.
System Miscellany	Route Unit: 8	

Audio Keywords in the Software Initialisation Configuration File

There are two keywords in the software initialization file (by default, *init.cfg*) that must be uncommented and set to the correct values to ensure Discreet Native Audio works properly. The first, `Audiodevice`, enables Discreet Native Audio. The second, `MidiDevice`, determines whether control of the Lucid converter is remote or local.

Keyword:	Setting:
<code>Audiodevice</code>	AJA
<code>MidiDevice</code>	If you are using local control of the converter, comment out this keyword. If you are using remote control of the converter, uncomment the keyword, set the serial port parameter to <code>/dev/ttyS1</code> and leave all other parameters set to their default value.

For additional information on these keywords and help setting them, see the *Configuration File Reference Guide for Linux Workstations*.

index

A

ADA converter. See Lucid ADA converter
air conditioning, requirements 7
audio
 Discreet Native Audio 33
 hardware components 34
 keywords in software initialisation file 40
 wiring workflow 33

C

configuring, Lucid ADA converter 38

D

Discreet Native Audio 33
documentation
 set of guides 1

E

emulation, setting up VTR 23

H

hardware configuration guidelines 3

I

initialisation file keywords, audio 40

K

keyboard, connecting 14

L

Lucid ADA converter
 configuring 38

hardware control 37

M

memory requirements 7
mouse, connecting 14

N

notation conventions 9

P

power, requirements 7

S

software initialisation file, audio keywords 40

T

tablet, connecting 14

V

video hardware components 17
VTR emulation, setting up 23

W

Wire network, connecting to 14
workflow
 audio wiring 33
 hardware setup and software installation 3, 5

