

IBM® Z PRO 6223 WORKSTATION

# Hardware Setup Guide



© 2007 Autodesk Canada Co./Autodesk, Inc. All rights reserved. Except as otherwise permitted by Autodesk Canada Co./Autodesk, Inc., this publication, or parts thereof, may not be reproduced in any form, by any method, for any purpose.

Copyright © 2003 NetGroup, Politecnico di Torino. All rights reserved.

Neither the name of "Politecnico di Torino" nor the names of its contributors may be used to endorse or promote products derived from this software without prior written permission. THIS SOFTWARE IS PROVIDED BY THE COPYRIGHT HOLDERS AND CONTRIBUTORS "AS IS" AND ANY EXPRESS OR IMPLIED WARRANTIES, INCLUDING, BUT NOT LIMITED TO, THE IMPLIED WARRANTIES OF MERCHANTABILITY AND FITNESS FOR A PARTICULAR PURPOSE ARE DISCLAIMED.

IN NO EVENT SHALL THE COPYRIGHT OWNER OR CONTRIBUTORS BE LIABLE FOR ANY DIRECT, INDIRECT, INCIDENTAL, SPECIAL, EXEMPLARY, OR CONSEQUENTIAL DAMAGES (INCLUDING, BUT NOT LIMITED TO, PROCUREMENT OF SUBSTITUTE GOODS OR SERVICES; LOSS OF USE, DATA, OR PROFITS; OR BUSINESS INTERRUPTION) HOWEVER CAUSED AND OR ANY THEORY OF LIABILITY, WHETHER IN CONTRACT, STRICT LIABILITY, OR TORT (INCLUDING NEGLIGENCE OR OTHERWISE) ARISING IN ANY WAY OUT OF THE USE OF THIS SOFTWARE, EVEN IF ADVISED OF THE POSSIBILITY OF SUCH DAMAGE. This product includes software developed by the University of California, Lawrence Berkeley Laboratory and its contributors.

Copyright 2007 Autodesk Canada Co./Autodesk, Inc. Licensed under the Apache License, Version 2.0 (the "License"); you may not use this file except in compliance with the License. You may obtain a copy of the License at <http://www.apache.org/licenses/LICENSE-2.0>. Unless required by applicable law or agreed to in writing, software distributed under the License is distributed on an "AS IS" BASIS, WITHOUT WARRANTIES OR CONDITIONS OF ANY KIND, either express or implied. See the License for the specific language governing permissions and limitations under the License.

Powered by Automatic Duck © 2006 Automatic Duck, Inc. All rights reserved.

Portions copyright 1991-2006 Compuware Corporation.

Portions of this product Copyright 2006 Glyph & Cog, LLC.

DIRAC Time Stretch/Pitch Shift technology licensed from The DSP Dimension, <http://www.dsdimension.com> Developed and (c) 2005 Stephan M. Bernsee

## Trademarks

The following are registered trademarks or trademarks of Autodesk, Inc., in the USA and other countries: 3DEC (design/logo), 3December, 3December.com, 3ds Max, ActiveShapes, Actrix, ADI, Alias, Alias (swirl design/logo), AliasStudio, Alias|Wavefront (design/logo), ATC, AUGI, AutoCAD, AutoCAD Learning Assistance, AutoCAD LT, AutoCAD Simulator, AutoCAD SQL Extension, AutoCAD SQL Interface, Autodesk, Autodesk Envision, Autodesk Insight, Autodesk Intent, Autodesk Inventor, Autodesk Map, Autodesk MapGuide, Autodesk Streamline, AutoLISP, AutoSnap, AutoSketch, AutoTrack, Backdraft, Built with ObjectARX (logo), Burn, Buzzsaw, CAiCE, Can You Imagine, Character Studio, Cinestream, Civil 3D, Cleaner, Cleaner Central, ClearScale, Colour Warper, Combustion, Communication Specification, Constructware, Content Explorer, Create>what's>Next> (design/logo), Dancing Baby (image), DesignCenter, Design Doctor, Designer's Toolkit, DesignKids, DesignProf, DesignServer, DesignStudio, Design|Studio (design/logo), Design Your World, Design Your World (design/logo), DWF, DWG, DWG (logo), DWG TrueConvert, DWG TrueView, DXF, EditDV, Education by Design, Extending the Design Team, FBX, Filmbox, FMDesktop, Freewheel, GDX Driver, Gmax, Heads-up Design, Heidi, HOOPS, HumanIK, i-drop, iMOUT, Incinerator, IntroDV, Inventor, Inventor LT, Kaydara, Kaydara (design/logo), LocationLogic, Lustre, Maya, Mechanical Desktop, MotionBuilder, ObjectARX, ObjectDBX, Open Reality, PolarSnap, PortfolioWall, Powered with Autodesk Technology, Productstream, ProjectPoint, Reactor, RealDWG, Real-time Roto, Render Queue, Revit, Showcase, SketchBook, StudioTools, Topobase, Toxik, Visual, Visual Bridge, Visual Construction, Visual Drainage, Visual Hydro, Visual Landscape, Visual Roads, Visual Survey, Visual Syllabus, Visual Toolbox, Visual Tugboat, Visual LISP, Voice Reality, Volo, and Wiretap.

The following are registered trademarks or trademarks of Autodesk Canada Co. in the USA and/or Canada and other countries: Backburner, Discreet, Fire, Flame, Flint, Frost, Inferno, Multi-Master Editing, River, Smoke, Sparks, Stone, Wire.

All other brand names, product names or trademarks belong to their respective holders.

## Disclaimer

THIS PUBLICATION AND THE INFORMATION CONTAINED HEREIN IS MADE AVAILABLE BY AUTODESK CANADA CO./AUTODESK, INC. "AS IS." AUTODESK CANADA CO./AUTODESK, INC., DISCLAIMS ALL WARRANTIES, EITHER EXPRESS OR IMPLIED, INCLUDING BUT NOT LIMITED TO ANY IMPLIED WARRANTIES OF MERCHANTABILITY OR FITNESS FOR A PARTICULAR PURPOSE REGARDING THESE MATERIALS.

Published by:

Autodesk Canada Co./Autodesk, Inc.

111 McInnis Parkway

San Rafael, CA 94903, USA

Title: Autodesk Lustre 2008 IBM Z Pro 6223 Workstations Hardware Setup Guide

Document Version: 1

Date: September 19, 2007

# contents

## Contents

---

<b>1</b>	<b>Introduction</b>	<b>1</b>
	Summary .....	1
	About This Guide .....	1
	The Lustre Workgroup .....	1
	Optional Lustre Components .....	3
	Typical Lustre Configuration Overview .....	4
	Workflow for Hardware Setup and Application Installation .....	5
	Related Documentation .....	5
	Hardware Configuration Guidelines .....	6
	Notation Conventions .....	9
	Contacting Customer Support .....	10
<b>2</b>	<b>Connecting Peripherals</b>	<b>13</b>
	Summary .....	13
	Workflow for Connecting Peripherals .....	13
	Connection Diagrams for the IBM 6223/FX5500 with SDI Card in Punchout .....	14
	Connection Diagram for the IBM 6223/FX5500 with SDI Card in PCI Slot .....	16
	Connection Diagrams for the IBM 6223/NVIDIA FX4000 .....	17
	Upgrading the FX4000 to the FX5500 .....	19
	Connecting the Keyboard and Mouse .....	20
	Connecting the Monitor .....	20
	Connecting the Monitor Calibration Device .....	20
	Connecting Storage .....	21
	Network Connections .....	23

<b>3</b>	<b>Connecting System Components</b>	<b>25</b>
	Summary .....	25
	Workflow for Connecting System Components in the Lustre Workgroup .....	25
	Connecting the Autodesk Control Surface .....	26
	Assigning an IP Address to the Autodesk Control Surface .....	28
	Configuring Lustre to Connect to the Autodesk Control Surface .....	31
	Connecting the Tangent CP100 Control Surface .....	31
	Connecting a Stand-Alone Tablet .....	32
	Connecting the Slave Renderer to a Lustre Workstation .....	33
	Connecting Video I/O to a Master or HD Station .....	34
	Connecting to a High-Speed Data Link Device (HSDL) .....	43
	<b>Index</b>	<b>45</b>



# Introduction

## Summary

<a href="#">About This Guide</a> .....	1
<a href="#">The Lustre Workgroup</a> .....	1
<a href="#">Optional Lustre Components</a> .....	3
<a href="#">Typical Lustre Configuration Overview</a> .....	4
<a href="#">Workflow for Hardware Setup and Application Installation</a> .....	5
<a href="#">Related Documentation</a> .....	5
<a href="#">Hardware Configuration Guidelines</a> .....	6
<a href="#">Notation Conventions</a> .....	9
<a href="#">Contacting Customer Support</a> .....	10

## About This Guide

This guide describes how to set up the IBM® IntelliStation® Z Pro 6223 workstation and the other hardware components of your Autodesk® Lustre® 2008 workgroup. Use this guide in conjunction with the *Autodesk Lustre 2008 Software Installation Guide* for your operating system and the *Stone Direct Configuration Guide* to install and configure the hardware and software components of Lustre.

**NOTE:** In most cases, both hardware setup and application installation is done on delivery by an authorized technician, so you may not need to perform some of the procedures in these guides.

The latest versions of all guides are available in PDF format from the Web at [www.autodesk.com/discreet-documentation](http://www.autodesk.com/discreet-documentation). For best results viewing and printing these PDF files, use Adobe® Acrobat® Reader™ 6 or later.

## The Lustre Workgroup

Lustre is a modular system that you can configure and expand to suit your needs. The features you purchase determine the hardware included with your system.

Central to any system is the Master Station or HD Station. The Master Station is a high-end Windows®- or Linux®-based PC designed to accommodate real-time interactivity in a client-attended or supervised session. You can add a Lustre Station to improve the efficiency of your pipeline.

**Master Station** — Includes the full Lustre toolset and is designed for GPU-accelerated sessions where the colorist works together with the cinematographer. Contains an extensive creative toolset for more elaborate visual design and grading using up to 4K resolution and 16-bit files and for completing tasks like dust removal, conforming, rotoscoping and capture/payout.

**HD Station** — Cost-effective GPU workstation for conforming, preparing, grading and mastering short-form and long-form HDTV projects, as well as HD film projects. Input up to 10-bit 2K and output HD and SD.

**Lustre Station** — Tasks that do not require the direct intervention or supervision of the colorist can be efficiently handled by a Lustre Station. Multiple Lustre Stations can work in parallel to increase throughput and can be used for tasks such as dust removal, preparatory work, fine-tuning creative sessions, conforming data from EDLs, updating editorial changes using change lists, and mastering to different formats using the real-time deliverables function.

## Lustre Workstation Features

The following table describes the features available to each Lustre workstation.

**NOTE:** The features of Lustre 2008 may vary based on your hardware platform. Consult the *Autodesk Lustre 2008 Release Notes* for details.

Station	Configuration
Master Station	<p><b>Default</b> — All features are available including SD and HD I/O, dual link and HSDL video formats and the DI Pack, which consists of infrared channel dust removal and support for all standard input and output resolutions and bit-depths. Certain features require add-on licensing.</p> <p><b>Add-Ons</b> — The following features can be added to the Default configuration: the Slave Renderer and up to three panels for the Autodesk control surface. The Slave Renderer requires a separate license.</p>

Station	Configuration
Lustre HD Station	<p><b>Default</b> — Includes all features except for the DI Pack (see the Master Station description). File input is limited to 2K resolution. File output is limited to HD resolution, 10-bit. Certain features require add-on licensing.</p> <p><b>Add-Ons</b> — The following features can be added to the Default configuration: SD and HD I/O, dual link and HSDL video formats, the Slave Renderer, and up to three panels for the Autodesk control surface. The Slave Renderer requires a separate license.</p>
Lustre Station	<p><b>Default</b> — All features are available except for primary and secondary colour grading. The DI Pack (see the Master Station description) is also included, along with full dust removal functionality, and the ability to create geometries and masks.</p> <p><b>With Primary Colour Correction</b> — Includes all features of the default configuration as well as primary colour grading.</p> <p><b>Add-Ons</b> — The following features are available for either the Default configuration or the With Primary Colour Correction configuration, and require an additional license: SD and HD I/O, dual link and HSDL video formats, and up to three panels for the Autodesk control surface. The Slave Renderer requires a separate license.</p>

## Optional Lustre Components

You can expand the features of your Lustre system and improve the efficiency of your workflow by adding any of the following components.

**Control Surface** — The Autodesk control surface provides improved interactivity when colour grading film and video footage. You can perform many of the same tasks you do in the Lustre user interface using the control surface.

**Video I/O** — Video I/O is provided by the DVS Centaurus® board, which consists of an HD/SD board and a breakout box. This configuration provides real-time SDI input and output of uncompressed 8- or 10-bit HD or SD video in both YUV (4:2:2) and RGB formats (4:4:4 or 4:2:2).

For a list of supported video formats, see the *Autodesk Lustre 2008 User's Guide*.

**Slave Renderer** — The Slave Renderer is a rack-mounted server that is connected directly to the Lustre workstation. It frees system resources by off-loading render tasks on an 'as-needed' basis, thus ensuring real-time interaction on the Lustre system.

**Background Renderer** — Background rendering frees up Lustre workstations for colour grading. You can use up to eight background rendering machines to process your final frames.

**NOTE:** For a list of Incinerator system components, refer to the *Autodesk Incinerator 2008 Installation and User's Guide*.

# Typical Lustrre Configuration Overview

The following illustration shows a typical configuration, including the Master Station, Lustrre Station, and other optional components.

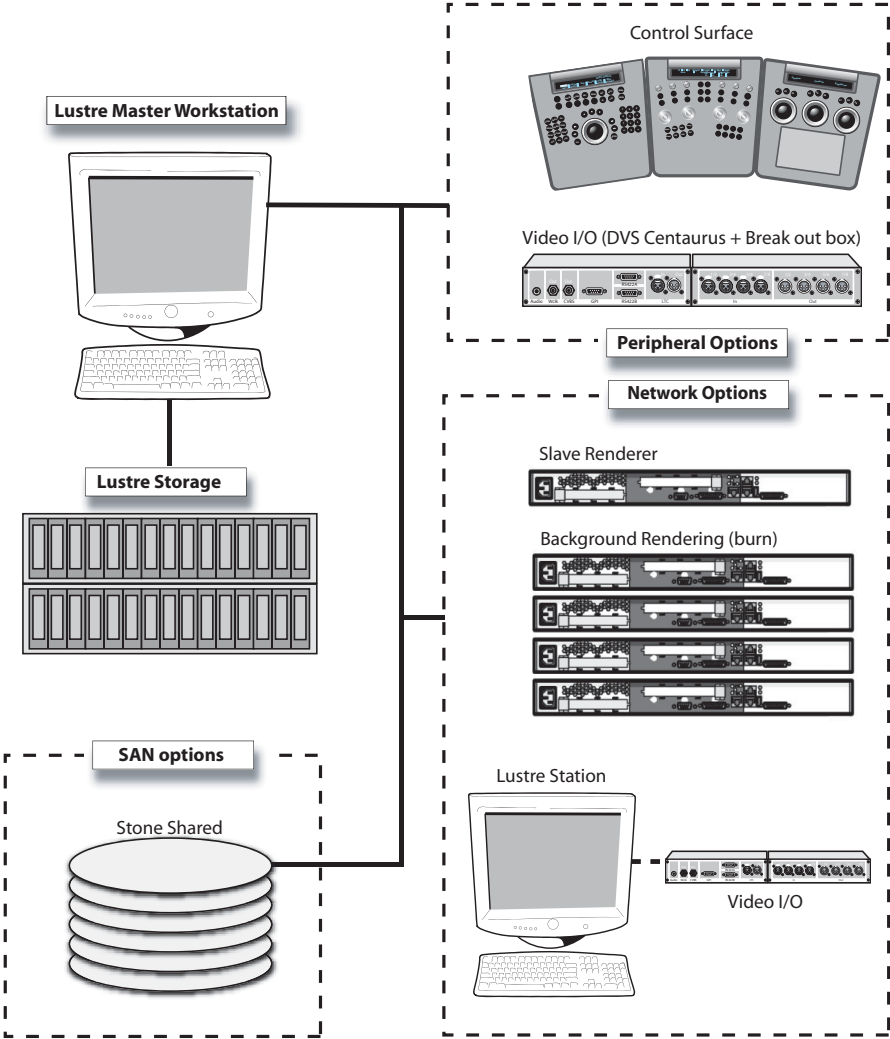

**NOTE:** For an Incinerator system configuration overview, refer to the *Autodesk Incinerator 2008 Installation and User's Guide*.

## Workflow for Hardware Setup and Application Installation

The following procedure provides the general workflow for installing Lustre on an IBM 6223 workstation.

### To install Lustre on an IBM 6223 workstation:

1. Review the guidelines for working with hardware components. See [“Hardware Configuration Guidelines”](#) on page 6.
2. Connect all peripherals (mouse, keyboard, graphics monitor, storage, etc.) to each workstation in your workgroup, and connect each workstation to the network. See [Chapter 2, “Connecting Peripherals.”](#) on page 13.
3. Connect your workstation to Autodesk Stone® Direct storage. See the *Stone Direct Configuration Guide*.
4. Connect your Master or HD Station to a Slave Renderer, a control surface, tablet, and video I/O components. See [Chapter 3, “Connecting System Components.”](#) on page 25.
5. Perform the procedures in the *Autodesk Lustre 2008 Software Installation Guide* for your operating system to install and license Lustre.

## Related Documentation

The following table describes the documentation associated with your application. For a detailed list of the latest documentation, see your release notes.

User Guides	Provides
<i>Autodesk Lustre 2008 User's Guide</i>	Detailed instructions on using the software.
<i>Autodesk Control Surface User's Guide</i>	Detailed instructions on using the Autodesk control surface and the Tangent CP100.
<i>Autodesk Lustre 2008 What's New</i>	A complete list of the new features for this release.
<i>Autodesk Lustre 2008 Hot Keys Card</i>	A list of the most frequently used hot keys.
<i>Autodesk Lustre 2008 Release Notes</i>	A complete list of documentation and information on late-breaking features.
<i>Autodesk Lustre 2008 Fixed and Known Bug List</i>	A complete list of fixed and known bugs for this release.
Installation and Configuration Guides	Provides
<i>Hardware Setup Guide</i> (for your workstation)	Information on how to set up your workstation and video I/O peripherals.
<i>Stone Direct Configuration Guide</i> (for this release)	Provides detailed connectivity diagrams and configuration procedures for your Stone storage arrays.

<b>Installation and Configuration Guides</b>	<b>Provides</b>
<i>Autodesk Lustre 2008 Software Installation Guide</i> (for your operating system)	Information about installing and licensing your Autodesk Lustre software.
<i>Stone and Wire Filesystem and Networking Guide</i> (for this release)	Procedures for configuring your Wiretap™ services.
<b>Other Guides</b>	<b>Provides</b>
<i>Autodesk Lustre Sparks API Reference Guide</i>	Instructions for developing Sparks® plugins for Lustre.
<i>Autodesk Backburner 2007 Installation and User's Guide</i>	Information on how to install, set up, and use Autodesk Backburner™.

Consult the Autodesk Web site at [www.autodesk.com/discreet-documentation](http://www.autodesk.com/discreet-documentation) for the latest version of guides, release notes, and fixed and known bugs documents.

## Hardware Configuration Guidelines

In most cases, hardware integration and application installation is done on delivery by an authorized technician, and some of the procedures in this guide may not be necessary. Still, it is a good idea to read through all chapters to familiarize yourself with the configuration procedures for the following reasons:

- Many suspected problems with your Lustre system may be due to loosened connections or improperly configured devices. This guide helps you troubleshoot problems by providing information about properly configured systems.
- If you need to call Customer Support, familiarity with this guide puts you in a better position to provide diagnostic information.
- If you want to move your Lustre system at any time, or upgrade certain hardware components, information in this guide is crucial.

Although this guide, in conjunction with the *Autodesk Stone Direct 2008 Configuration Guide*, provides complete information regarding configuring hardware components, hardware configuration should only be performed by an experienced hardware integrator familiar with Windows or Linux operating systems, IBM Z Pro workstations, and peripherals associated with professional high-performance video and post production of film.

Your Lustre system consists of high-performance hardware that must be configured in an environment suited to its operational needs. Other considerations include minimizing the risk of damage due to static discharge and ensuring all components are properly grounded.

## Verifying System BIOS Version and Settings

There are two models of the IBM Z Pro 6223. Model 64U was the first shipped for Incinerator systems. This model was replaced by the 7DU when the Restriction of Hazardous Substances (RoHS) European Union directive took effect.

- The current certified system BIOS version for the 64U model is 1.52A.
- The current certified system BIOS version for the 7DU model is 1.66A.

If the IBM workstation is using a different BIOS version, you must update it for this release. Instructions for updating the BIOS on your IBM 6223 workstation are provided in articles available on the IBM Web site.

For the 64U model, refer to:

<http://www-307.ibm.com/pc/support/site.wss/document.do?sitestyle=ibm&lnocid=MIGR-56667>

For the 7DU model, refer to:

<http://www-304.ibm.com/jct01004c/systems/support/supportsite.wss/docdisplay?lnocid=MIGR-57658&brandind=5000004>

**NOTE:** You do not normally need to adjust these settings. BIOS settings for the workstation are provided here for informational purposes only.

To enter the system BIOS, you must press **F1** while booting the workstation.

The following table lists the proper Autodesk certified BIOS settings. Items not listed are set to their default factory settings.

BIOS Menu	Item	Value
Devices and I/O ports	Parallel Port	Disabled
	Serial ATA	Disabled
Startup Options, Startup Sequence Options, Primary Startup Sequence	First Startup Device	Removable
	Second Startup Device	Hard Disk
	Third Startup Device	CD/DVDROM
	Fourth Startup Device	Disabled
Startup Options, Startup Sequence	Wake on LAN	Off
Startup Options	Planar PXE/DHCP Priority	Normal
	PCI Device Boot Priority	SLOT 1

BIOS Menu	Item	Value
	Boot Fail Count (only in version 1.66 A on model 7DU)	Disabled
Advanced Setup, CPU Options	Hyper Threading Technology	Disabled

## Ensuring Proper Environmental Conditions

You should consider the following environmental guidelines for all hardware configurations:

- Make sure the rack in which hardware components are installed is open or ventilated. Follow the ventilation specifications that apply to your system.
- Place all components in an air-conditioned environment. All hardware components generate heat and must be kept cool. See [“Power and Air Conditioning Requirements”](#) on page 8.
- Keep all hardware components in a clean, dust-free location.
- Minimize vibration and humidity.
- Do not block the vents on the component housing.
- Do not drape anything, such as a jacket or a blanket, over hardware components.
- Minimize electromagnetic noise by separating digital data and power cables from analog audio cables and running them in different cable ducts.

## Power and Air Conditioning Requirements

The values for power consumption and heat output were recorded on an Autodesk certified system with all of the required peripheral and certified components.

**NOTE:** These values can fluctuate if uncertified hardware components or third-party applications are added to your system. The use of uncertified hardware components or third-party applications is not supported. Please consult the manufacturer’s documentation for standardized minimum and maximum values.

The following table summarizes the power consumed by the IBM 6223 system and the heat it generates under the maximum processing load produced by your Lustre system. For detailed specifications, including noise output, see the documentation provided by the manufacturer.

Component	Quantity	Startup Amps (120V / 240V)	Max. Amps (120V / 240V)	Watts	Heat (BTUs)
IBM Z Pro 6223	1	3.5/1.8	2.6/1.3	420	1433

You must be able to meet the startup power requirement and have a climate control system with the capacity to maintain the temperature of this component under the maximum processing load. Refer to the following table for standard conversion benchmarks and an example of how they are used to establish climate control requirements.

Unit Conversion	Example
1 Watt = 3.413 BTU	480 Watts = 1638 BTU
12000 BTU = 1 Ton of air conditioning	1638 BTU = 0.137 Ton of air conditioning

For Incinerator power consumption and air conditioning requirement values, refer to the *Connecting Components and Peripherals* chapter of the *Autodesk Incinerator 2008 Installation and User's Guide*.

## Avoiding Damage from Static Electricity

When installing any hardware equipment, take the following precautions to prevent damage to sensitive components from static discharge:

- Make sure power is turned off on the component you are working on. It is a good idea to unplug components until all other connections are configured.
- Always wear a grounded static wrist strap. Attach the strap's alligator clip to any grounded metal surface on the component's chassis that you are working on. Place the wristband around your wrist.
- Do not handle any components unnecessarily, particularly boards and cards that slide in and out of slots on their parent hardware components.

## Grounding Hardware Components

It is important to properly ground any audio components used with Lustre to avoid ground loops and humming. To ensure audio components are properly grounded, use the XLR-3 cables. Using any other cables may cause humming in the system.

## Receiving Your Lustre

When you receive the shipment containing your Lustre, check all the boxes for dents or other markings that may indicate damage during transport. If you suspect a component is damaged, carefully inspect it before setting up the system. If you receive a damaged component, call Customer Support.

Use the enclosed packing checklist to ensure you received all parts.

## Notation Conventions

A number of style conventions are used throughout this guide. These conventions and examples of their use are shown as follows.

Convention	Example
Text that you enter in a command line or shell appears in Courier bold. You must press the Enter key after each command.	<b>rpm -qa</b>
Variable names appear in Courier, enclosed in angle brackets. No spaces are allowed in variable names.	<variable_name>
Variables that appear enclosed in square brackets are optional.	[<filename>]
Feedback from the command line or shell appears in Courier.	limit coredumpsize
Directory names, filenames, URLs, and command line utilities appear in italics.	<i>/usr/discreet</i>

## Contacting Customer Support

You can contact Autodesk Media and Entertainment Customer Support at [www.autodesk.com/support](http://www.autodesk.com/support) or through one of the following ways:

Location:	Contact Information:
Within the Americas:	Hotline (North America): 1-800-925-6442 Direct dial: 415-507-5256 (Country code = 1) 8 AM to 8 PM EST Monday to Friday, excluding holidays <i>me.support@autodesk.com</i>
Within Europe, Middle-East and Africa:	Hotline (from London, UK): +44-207-851-8080 9 AM to 5:30 PM (local time) Monday to Friday, excluding holidays <i>me.emea.support@autodesk.com</i>
Within Asia Pacific: (Excluding India, China, Australia, New Zealand and Japan)	Hotline (from Singapore): +65-6555-0399 9 AM to 6 PM (local time) Monday to Friday, excluding holidays <i>me.support.singapore@autodesk.com</i>
Within India:	Hotline (from Mumbai): +91-22-6695-2244 9:30 AM to 6:30 PM (local time) Monday to Friday, excluding holidays <i>me.support.india@autodesk.com</i>
Within Japan:	Hotline (from Tokyo): 0120-107-290 Direct dial: +81-3-6221-1810 10 AM to 6 PM (local time) Monday to Friday, excluding holidays <i>med-sys-support-jp@autodesk.com</i>

<b>Location:</b>	<b>Contact Information:</b>
Within China:	Direct dial: +86-10-6505-6848 9 AM to 6 PM (local time) Monday to Friday, excluding holidays <i>me.support.china@autodesk.com</i>
Within Australia and New Zealand:	Hotline (from Melbourne): +1-300-36-8355 Direct dial: +61-3-9876-8355 8 AM to 6 PM AEST Monday to Friday, excluding holidays <i>me.support.anz@autodesk.com</i>

Customer support is also available through your Autodesk reseller. To find a reseller near you, consult the reseller look-up database on the Autodesk web site at [www.autodesk.com/resellers](http://www.autodesk.com/resellers).



# Connecting Peripherals



## Summary

<a href="#"><u>Workflow for Connecting Peripherals</u></a> .....	13
<a href="#"><u>Connection Diagrams for the IBM 6223/FX5500 with SDI Card in Punchout</u></a> .	14
<a href="#"><u>Connection Diagram for the IBM 6223/FX5500 with SDI Card in PCI Slot</u></a> ....	16
<a href="#"><u>Connection Diagrams for the IBM 6223/NVIDIA FX4000</u></a> .....	17
<a href="#"><u>Upgrading the FX4000 to the FX5500</u></a> .....	19
<a href="#"><u>Connecting the Keyboard and Mouse</u></a> .....	20
<a href="#"><u>Connecting the Monitor</u></a> .....	20
<a href="#"><u>Connecting the Monitor Calibration Device</u></a> .....	20
<a href="#"><u>Connecting Storage</u></a> .....	21
<a href="#"><u>Network Connections</u></a> .....	23

## Workflow for Connecting Peripherals

You must connect peripherals (monitor, keyboard, mouse, storage, and network) to each Lustre workstation before you connect the workstations to video I/O, a control surface, or to other components in the workgroup.

Connect all hardware peripherals before you boot your workstation.

See the following table for a summary of the steps necessary to connect peripherals to your Lustre workstation.

Step:	Refer to:
1. Review the connection diagram for your workstation.	<ul style="list-style-type: none"> <li>• <a href="#">“Connection Diagrams for the IBM 6223/FX5500 with SDI Card in Punchout”</a> on page 14.</li> <li>• <a href="#">“Connection Diagram for the IBM 6223/FX5500 with SDI Card in PCI Slot”</a> on page 16.</li> <li>• <a href="#">“Connection Diagrams for the IBM 6223/NVIDIA FX4000”</a> on page 17.</li> </ul>
2. Connect a keyboard and mouse to your workstation.	<a href="#">“Connecting the Keyboard and Mouse”</a> on page 20.
3. Connect a monitor to the workstation.	<a href="#">“Connecting the Monitor”</a> on page 20.
4. Connect a calibration device to the workstation.	<a href="#">“Connecting the Monitor Calibration Device”</a> on page 20.
5. Connect the workstation to storage.	<a href="#">“Connecting Storage”</a> on page 21.
6. Connect the workstation to your network.	<a href="#">“Network Connections”</a> on page 23.
7. After you connect all the peripherals to your Lustre workstations, you can connect the workgroup components together.	<a href="#">Chapter 3, “Connecting System Components.”</a> on page 25.

## Connection Diagrams for the IBM 6223/FX5500 with SDI Card in Punchout

The following diagrams show the connections for an IBM 6223 workstation with a punchout to accommodate the NVIDIA® FX5500 SDI card. This configuration leaves an open slot for an optional card. On Windows-based workstations, an optional QLA adapter is available. On Linux workstations, you can select either an optional QLA adapter or an Infiniband adapter (standard on Incinerator).

You can upgrade your FX4000 card to an FX5500 yourself if you have enough slots for the main board and the NVIDIA SDI daughter card, or, if you have a punchout to accommodate the SDI card.

The following configurations require a punchout for the NVIDIA SDI card. The punchout must be performed by an authorized Autodesk technician. Contact your sales representative if you want to upgrade your workstation to this configuration.

**NOTE:** These diagrams provide an overview of video I/O connections. For more details, see [“Connecting Video I/O to a Master or HD Station”](#) on page 34.

Windows-Based  
 IBM IntelliStation Z Pro 6223  
 NVIDIA FX5500 with SDI Card in Punchout

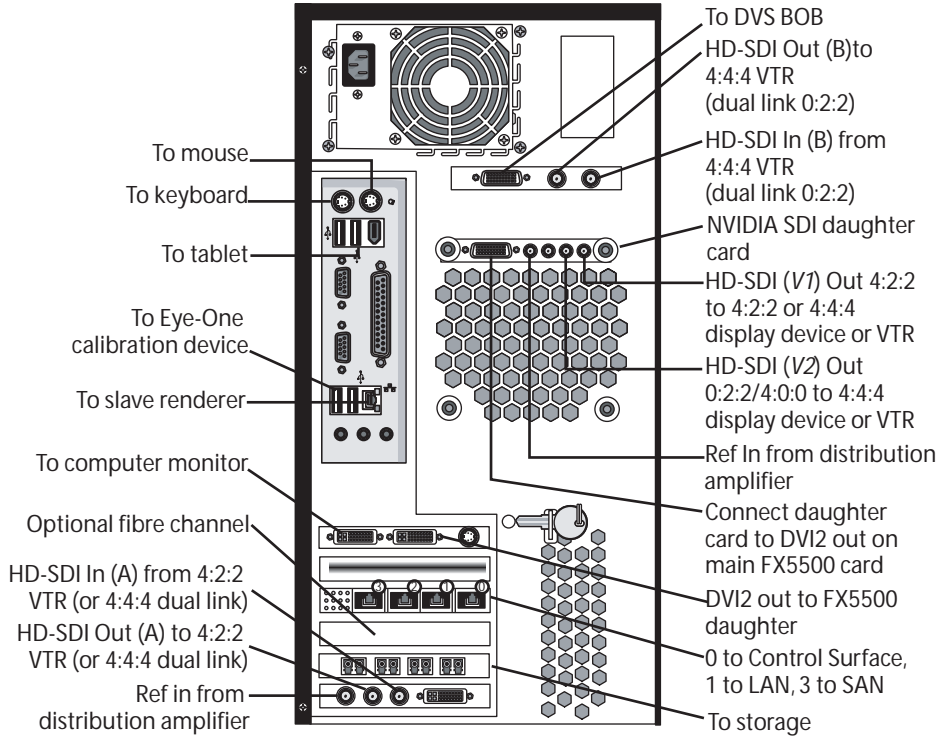

Linux-Based  
 IBM IntelliStation Z Pro 6223  
 NVIDIA FX5500 with SDI Card in Punchout

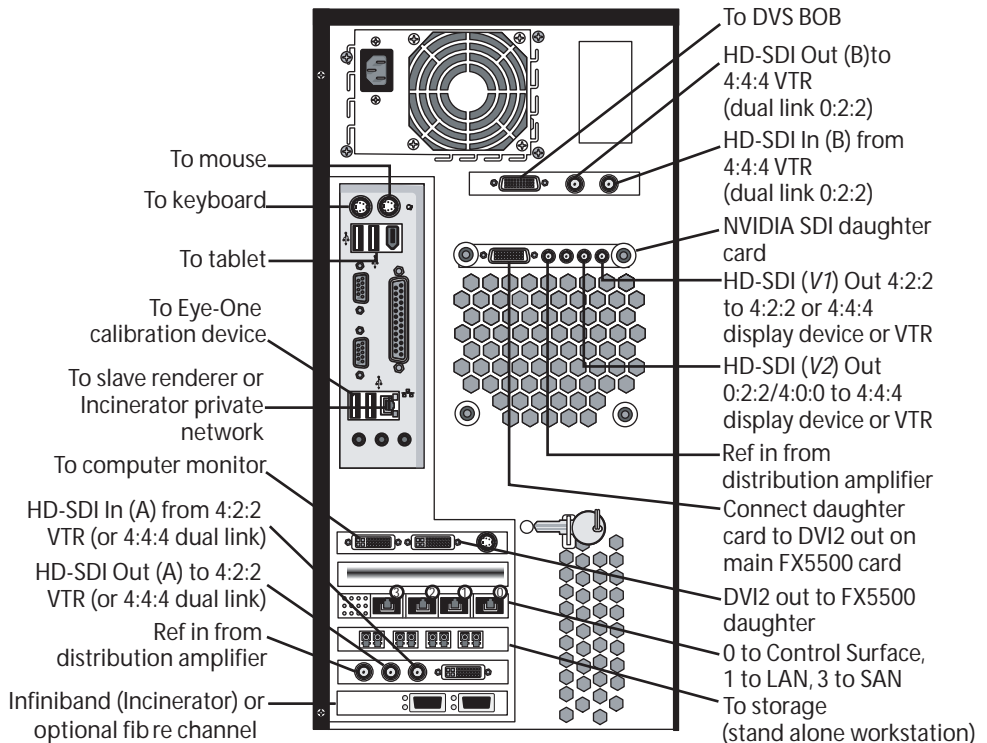

## Connection Diagram for the IBM 6223/FX5500 with SDI Card in PCI Slot

The following diagram shows the connections on a Windows-based 6223 workstation with the NVIDIA FX5500 SDI card in PCI slot 4, leaving no open slots for optional cards.

You can upgrade your workstation from an FX4000 to this configuration if slot 4 on your workstation is vacant. See [“Upgrading the FX4000 to the FX5500”](#) on page 19.

**NOTE:** This diagram provides an overview of video I/O connections. For more details, see [“Connecting Video I/O to a Master or HD Station”](#) on page 34.

Windows-Based  
 IBM IntelliStation Z Pro 6223  
 NVIDIA FX5500 with SDI Card in PCI Slot 4

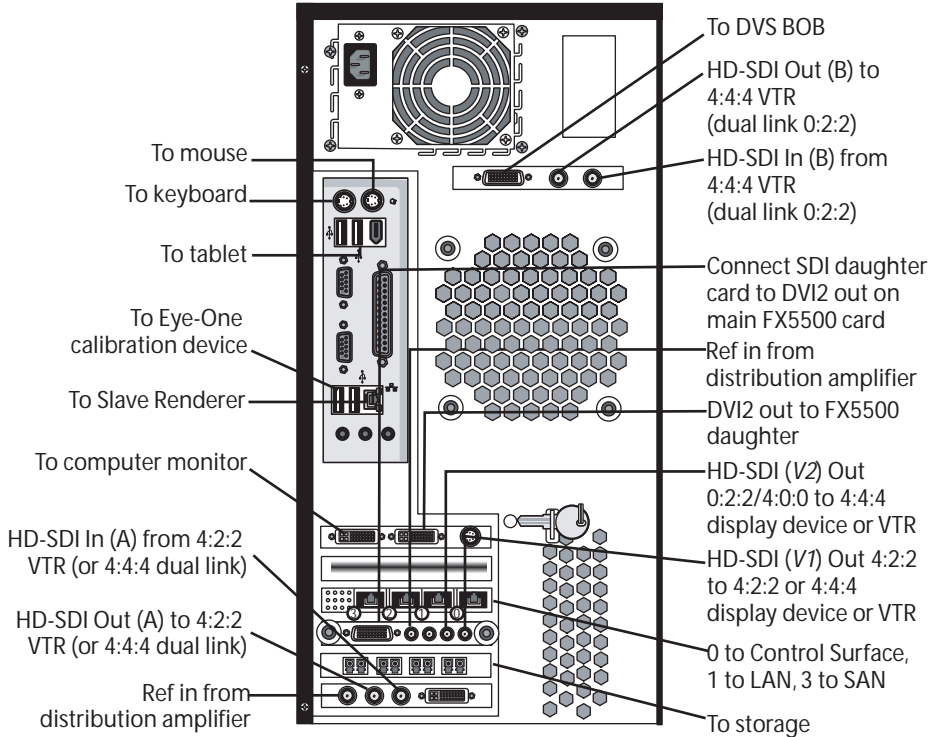

## Connection Diagrams for the IBM 6223/NVIDIA FX4000

The following diagrams show the connections on Windows- and Linux-based IBM 6223 workstations with the FX4000 graphics card.

**NOTE:** These diagrams provide an overview of video I/O connections. For more details, see [“Connecting Video I/O to a Master or HD Station”](#) on page 34.

Windows-Based  
IBM IntelliStation Z Pro 6223  
NVIDIA FX4000

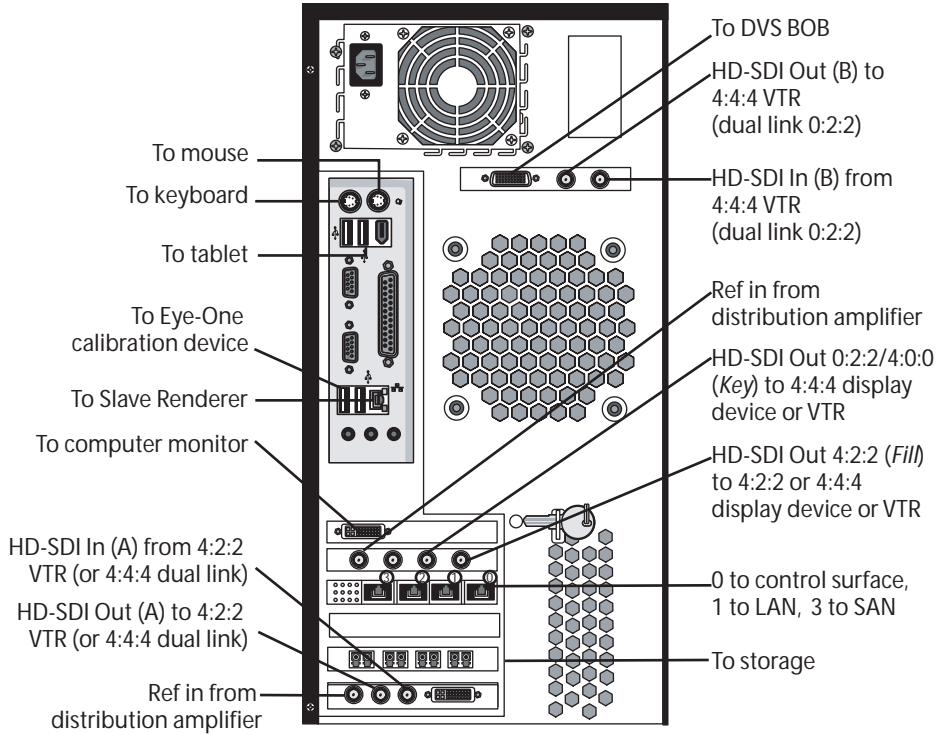

Linux-Based  
IBM IntelliStation Z Pro 6223  
with the FX4000 SDI

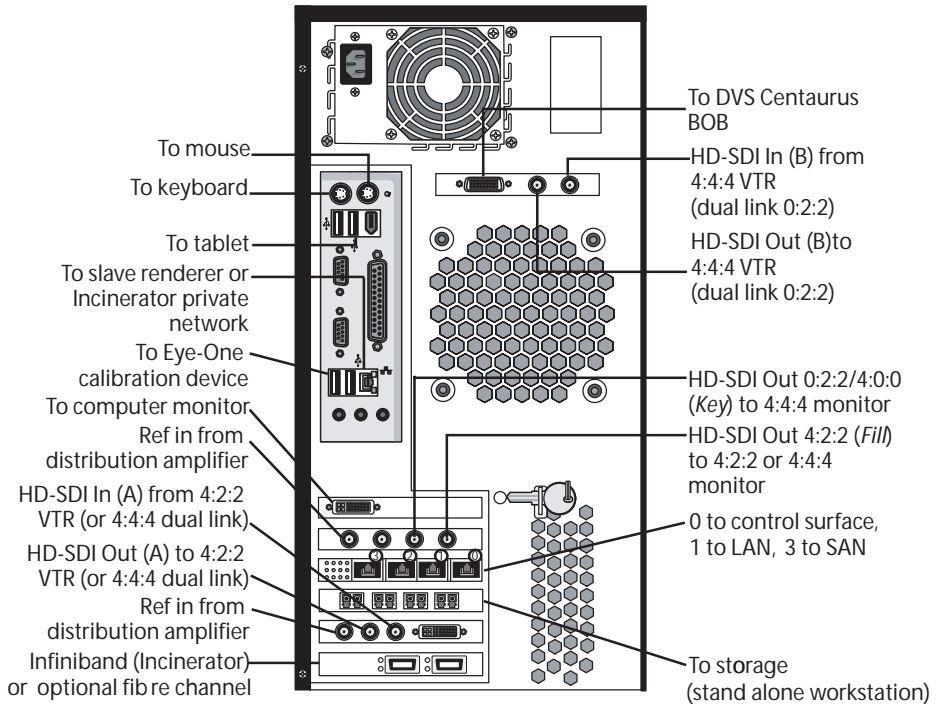

## Upgrading the FX4000 to the FX5500

You can upgrade your FX4000 card to an FX5500 if you have enough slots for the main board and the SDI daughter board, or if you have a punchout. The punchout must be performed by an authorized Autodesk technician. Contact your sales representative if you want to upgrade your workstation to this configuration.

After you upgrade to the FX5500 card, you must upgrade the driver. See the *Autodesk Lustre 2008 Release Notes* for the latest drivers and installation instructions.

**NOTE:** Contact your sales representative if you want to purchase an upgrade to the FX5500.

**To upgrade from the FX4000 to the FX5500:**

1. Follow the instructions provided by NVIDIA to remove the FX4000 card.
2. Follow the instructions provided by NVIDIA to install the FX5500 in the slot that was used by the FX4000 card.
3. Install the SDI daughter board in slot 4 on Windows-based workstations, or in the punchout on Windows- and Linux-based workstations that have one.

**NOTE:** The DVI-D cable that is supplied by NVIDIA to connect to the SDI daughter board is short. You may need to purchase a longer cable to connect the main board to the SDI daughter board.

## Connecting the Keyboard and Mouse

The mouse and keyboard are connected to ports on the back of the 6223 workstation. Refer to the hardware configuration documentation provided with the workstation for information on connecting these devices.

Cable kits are included to extend both the mouse and the keyboard connections.

## Connecting the Monitor

Connect the EIZO® 24-inch or Sony™ 21-inch LCD monitor to the DVI connection on the Lustre workstation's graphics card.

**To connect the monitor:**

- Do one of the following:
  - Connect the Gefen HDTV DVI-D fiber cable from the DVI OUT port of the NVIDIA FX4000 SDI PCI-E graphics card to the DVI IN port of the monitor.
  - Connect the Gefen HDTV DVI-D fiber cable from the DVI OUT1 port of the NVIDIA FX5500 SDI PCI-E graphics card to the DVI IN port of the monitor.

**NOTE:** Although the DVI fiber cable connectors are identical, their functions are different. Ensure that the connector labeled Send is connected to the Lustre workstation, and that the connector labeled Receive is connected to the monitor.

## Connecting the Monitor Calibration Device

Lustre uses the Eye-One Display 2 device for both LCD and CRT monitors. The calibration device is automatically detected when you launch Lustre.

**To connect the monitor calibration device:**

1. Connect the MINI2 USB extender for PC from either USB port on the Lustre workstation to the Eye-One Display 2 device.
2. On Windows-based workstations, you will be prompted to install the Eye-One USB driver when you restart the workstation, if the driver is not already installed. The driver is available from the `C:\Program Files\Autodesk\lustre3.0\Utils\Calibration\Eye-One USB Driver` directory.

On Linux-based workstations, start the `eyeone27` daemon on the workstation. Type:

```
/etc/init.d/eyeone27 start
```

## Connecting Storage

You can connect your workstation to two types of storage:

- One or more Stone Direct disk arrays that provide storage to individual workstations. Refer to the *Stone Direct 2008 Configuration Guide* for information on connecting disk arrays to your workstation.

**NOTE:** Incinerator workstations do not connect to Stone Direct disk arrays. Instead, they connect to a Lustre Media Server. Refer to the *Autodesk Incinerator 2008 Installation and User's Guide*.

- A Stone Shared storage area network (SAN) that provides shared storage for multiple workstations. Refer to the *Autodesk Stone Shared Installation and Configuration Guide* for information on connecting your workstation to a SAN.

Consult the Autodesk Web site at [www.autodesk.com/discreet-documentation](http://www.autodesk.com/discreet-documentation) for the latest version of these guides.

## Connecting and Configuring QLogic Fibre Channel Adapters

Your workstation is configured with a single QLogic™ QLA 2344 fibre channel adapter.

Consult the [“Connection Diagrams for the IBM 6223/FX5500 with SDI Card in Punchout”](#) on page 14, [“Connection Diagram for the IBM 6223/FX5500 with SDI Card in PCI Slot”](#) on page 16, and [“Connection Diagrams for the IBM 6223/NVIDIA FX4000”](#) on page 17 as a reference for QLogic fibre channel adapter locations.

The BIOS settings for these adapters must be properly configured. Each port on the QLogic boards that Autodesk shipped with your workstation have BIOS settings already configured. You can use the following procedure to verify and, if necessary, change the BIOS settings for each port on each adapter.

**To verify and/or change the QLogic BIOS settings:**

1. Reboot the system and, when the QLogic board starts initializing during the boot process, press **CTRL+Q** to enter the QLogic BIOS settings.

**NOTE:** The QLogic board takes only a few seconds to initialize, so you should follow the boot messages closely and be ready to press **CTRL+Q** as soon as you see the QLogic QLA board referenced in the boot messages.

2. For each port on each QLA adapter, verify the settings are as follows.

<b>Adapter Settings</b>	<b>Value</b>
BIOS Revision	1.43 <b>NOTE:</b> If the BIOS Revision is not 1.43, you must update the QLogic QLA board BIOS. Contact Autodesk Media and Entertainment Customer Support. Refer to <a href="#">“Contacting Customer Support”</a> on page 10. A representative will guide you through the update process.
Fiber Channel Tape Support	Disabled for ports attached to Stone Direct storage or a SAN. Enabled for ports attached to a fiber channel tape device.
Data Rate	1, for ports attached to Stone Direct storage. Ports connected to an archiving device should be set to 0. This configures the port to Auto Select throughput.
<b>Advanced Settings</b>	<b>Value</b>
Execution Throttle	255 When connected to a SAN, set to 5.
LUNs per Target	64

**NOTE:** This table only contains settings that have non-default values. Do not change any other settings. To restore all values to their default settings, refer to [“Restoring Default QLogic BIOS Settings”](#) on page 22.

**NOTE:** If you are not connecting the two outermost ports of a QLA 2344 fibre channel adapter to a storage device, you must terminate those ports using the terminators that shipped with your workstation. Terminating these ports significantly decreases the time required to boot your workstation.

**Restoring Default QLogic BIOS Settings**

If you are no longer certain which QLogic BIOS settings contain default values, you can use the following procedure to restore all settings to their default values.

**To restore all QLogic BIOS settings to their default values:**

1. Reboot the system and, when the QLogic board starts initializing during the boot process, press **CTRL+Q** to enter the QLogic BIOS settings.

**NOTE:** The QLogic board takes only a few seconds to initialize, so you should follow the boot messages closely and be ready to press **CTRL+Q** as soon as you see the QLogic QLA board referenced in the boot messages.

2. Select Configuration Settings from the main menu of the QLogic BIOS settings.
3. Select Restore Default Settings.

All settings are reset to their factory defaults.

## Network Connections

Connect each Lustre workstation to your facility's network to access background rendering (render farm), the Lustre Station, and the facility's NAS or SAN centralized storage (if applicable).

Connect Port 1 on the Broadcom card of the Lustre workstation to your house network.

For Linux, connect your Incinerator workstation to your facility's Incinerator private network. For instructions on how to connect to the Incinerator private network, consult the *Autodesk Incinerator 2008 Installation and User's Guide*.



# 3

## Connecting System Components

### Summary

- [Workflow for Connecting System Components in the Lustre Workgroup](#) . . . . 25
- [Connecting the Autodesk Control Surface](#) . . . . . 26
- [Assigning an IP Address to the Autodesk Control Surface](#) . . . . . 28
- [Configuring Lustre to Connect to the Autodesk Control Surface](#) . . . . . 31
- [Connecting the Tangent CP100 Control Surface](#) . . . . . 31
- [Connecting a Stand-Alone Tablet](#) . . . . . 32
- [Connecting the Slave Renderer to a Lustre Workstation](#) . . . . . 33
- [Connecting Video I/O to a Master or HD Station](#) . . . . . 34
- [Connecting to a High-Speed Data Link Device \(HSDL\)](#) . . . . . 43

### Workflow for Connecting System Components in the Lustre Workgroup

After you have connected peripherals to each Lustre workstation in your workgroup, you are ready to connect them to a control surface, to video I/O hardware, and to a Slave Renderer.

See the following table for a summary of the steps necessary to connect components in your workgroup.

Step:	Refer to:
1. Connect the control surface to your workstation.	For the Autodesk control surface: <a href="#">“Connecting the Autodesk Control Surface”</a> on page 26, <a href="#">“Assigning an IP Address to the Autodesk Control Surface”</a> on page 28, and <a href="#">“Configuring Lustre to Connect to the Autodesk Control Surface”</a> on page 31. For the Tangent CP100 control surface: <a href="#">“Connecting the Tangent CP100 Control Surface”</a> on page 31.
2. If necessary, connect a tablet to your workstation.	<a href="#">“Connecting a Stand-Alone Tablet”</a> on page 32.
3. Connect a Slave Renderer to the Lustre workstation.	<a href="#">“Connecting the Slave Renderer to a Lustre Workstation”</a> on page 33.
4. Connect the workstation to video I/O components.	<a href="#">“Connecting Video I/O to a Master or HD Station”</a> on page 34.
5. Connect the workstation to a high-speed data link device.	<a href="#">“Connecting to a High-Speed Data Link Device (HSDL)”</a> on page 43.

## Connecting the Autodesk Control Surface

The Autodesk control surface consists of three panels. You can use any combination of one or all of the panels.

If you will use more than one panel of the control surface, you must use the four port network switch to cross-connect all of the panels.

**NOTE:** The illustrations in this procedure contain a comprehensive IBM IntelliStation Z Pro 6223 backplane, since the Broadcom network card is in the same location independent of the platform running on the workstation. The illustrations also show the colour grading panel. The colour grading panel is the only one that has a USB connection for the integrated tablet.

**To connect the Autodesk control surface:**

1. Use the AC power adapter cables to connect each panel to a power supply.
2. Use a crossover cable to connect port 0 (the far right port) on the Broadcom network card on your workstation to port 1 on the network switch.

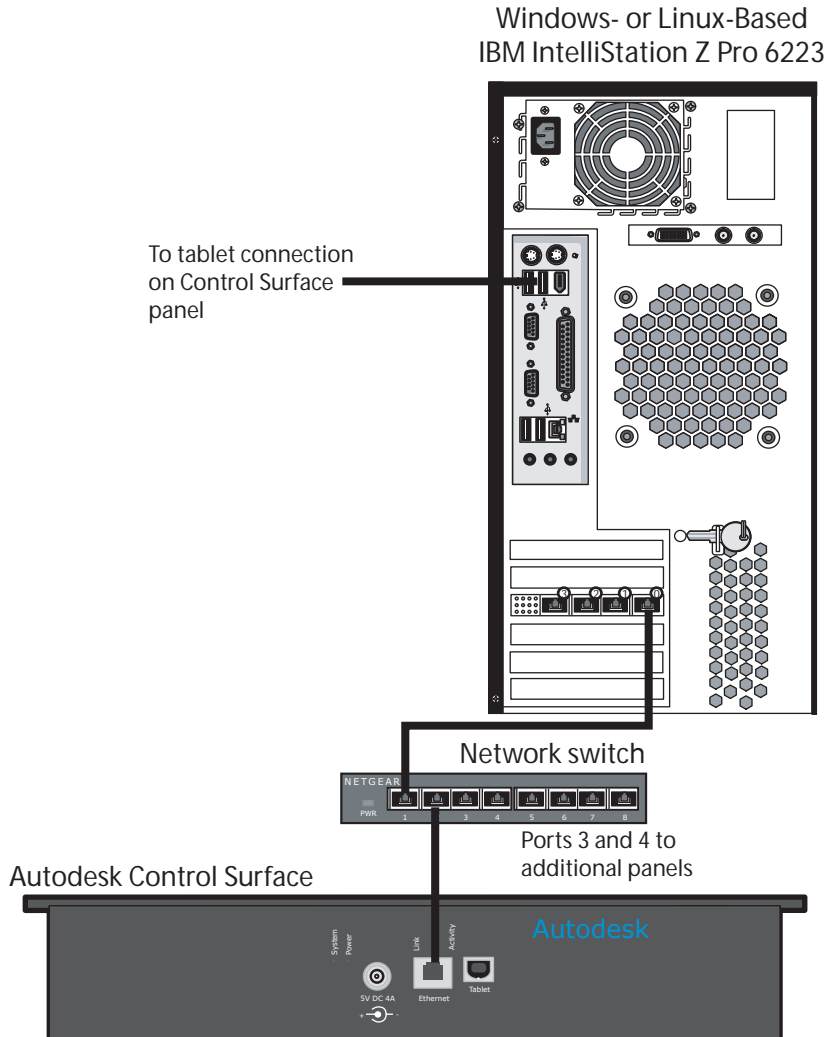

If you are using only one panel, you can connect that panel directly to the workstation, instead of using the switch.

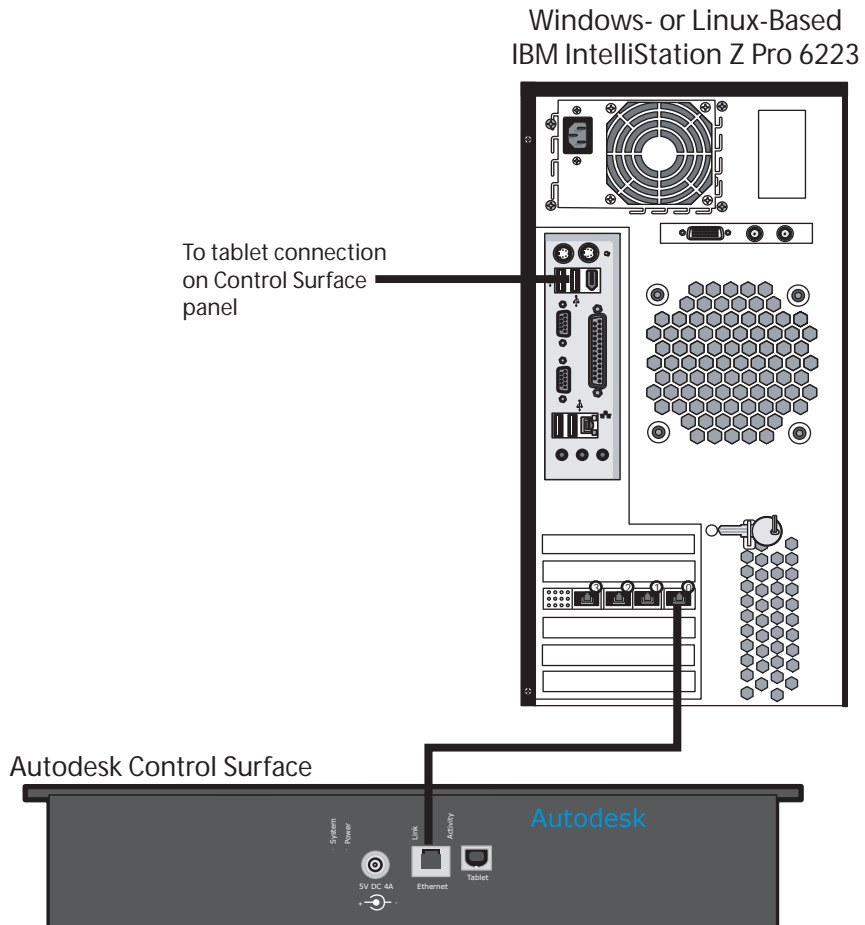

3. If you are using more than one panel, use network cables to connect each of the panels to the network switch.
4. If you are using the panel that includes the tablet, use a USB cable and extender to connect the panel to a USB port on the back of your workstation.

## Assigning an IP Address to the Autodesk Control Surface

After you have connected the Autodesk control surface, you must assign it an IP address.

**To assign an IP address to the Autodesk control surface on Windows-based workstations:**

1. Click Start | Settings | Network Connections.

**NOTE:** You can also access Network Connections from the Control Panel.

2. Right-click the port that the control surface switch or panel is connected to and choose Properties.
3. In the Properties dialog box, select Internet Protocol (TCP/IP) and click Properties.

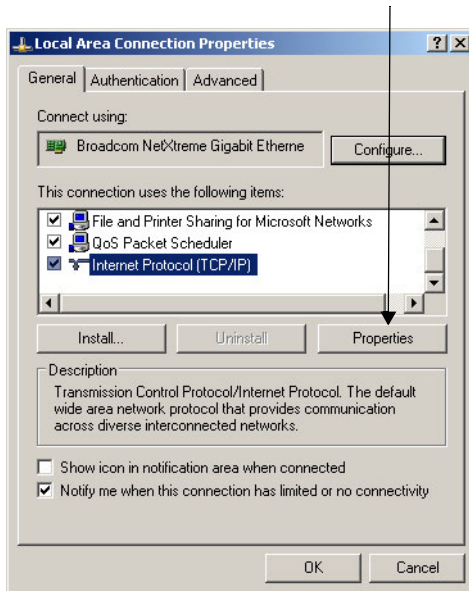

The Internet Protocol (TCP/IP) Properties dialog box opens.

- Select the Use the following IP address option.

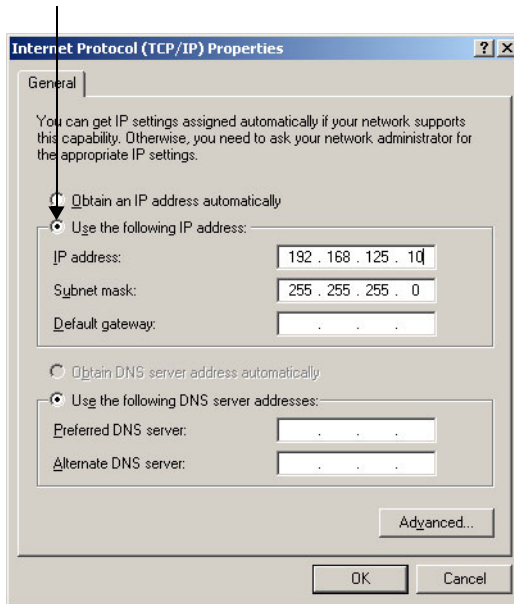

- Set a static IP and Subnet mask address for the port. Select values that do not conflict with any other machine on your network. Consider using the following values:

- IP address: 192.168.125.10
- Subnet mask: 255.255.255.0

**WARNING:** The last digits of the IP address must not conflict with the panel IDs included in the *lustre.config* file.

- Click OK twice.

**To assign an IP address to the Autodesk control surface on Linux-based workstations:**

- ▶ On the Lustre workstation, use a text editor such as *nedit* to configure the port connected to the control surface with an unrelated static IP address that will not interfere with any of the IP addresses on the network. Also assign an appropriate subnet mask. Type:

```
nedit /etc/sysconfig/network-scripts/ifcfg-eth<port#>
```

For example:

- IP address: 192.168.125.10
- Subnet mask: 255.255.255.0

 **WARNING:** The last digits of the IP address must not conflict with the panel IDs included in the *lustre.config* file.

## Configuring Lustre to Connect to the Autodesk Control Surface

After you have configured the IP address of the control surface, you must configure Lustre to use the control surface.

### To configure Lustre to use the Autodesk control surface on Windows- or Linux-based workstations:

1. Turn the power on to each of the modules and look at the top display panel on the module. It should display the panel name and ID.
2. After you install Lustre 2008, open the *lustre.config* file for each project and the *lustre.config* template file. See the *Autodesk Lustre 2008 Software Installation Guide*.
3. In the *lustre.config* file of your project, enter the panel ID after each panel keyword.

The keyword section should look similar to the following example.

```
AutodeskPanels
Panel-BT 1
Panel-K 2
Panel-T 3
```

4. Start Lustre. The following message should appear in the Console:

```
Panel #<panel_ID> is detected
```

The Autodesk control surface should now work.

## Connecting the Tangent CP100 Control Surface

The Tangent CP100 control surface is usually connected to the Master Station. You connect the control surface to the Master Station network port using a Category 5 crossover network cable. The control surface is automatically detected when Lustre is launched.

**NOTE:** The illustration in this procedure contains a comprehensive IBM IntelliStation Z Pro 6223 backplane, since the Broadcom network card is in the same location independent of the platform running on the workstation.

**To connect the Tangent CP100 control surface:**

1. Insert a crossover cable into port 0 (the far right port) on the Broadcom network card.

The Tangent CP100 control surface should be connected as shown in the following diagram.

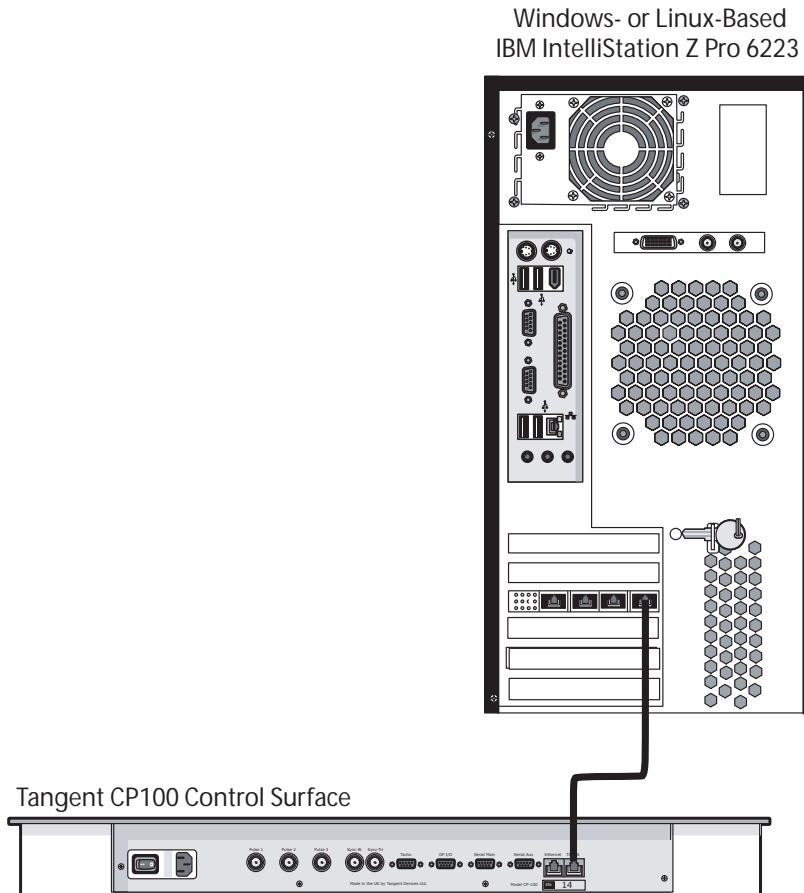

2. Connect the other end of the network cable to the TDLAN port of the Tangent control surface.

## Connecting a Stand-Alone Tablet

If you do not have the modular Autodesk control surface panel that includes the tablet, you can connect a stand-alone tablet to a USB port on the workstation.

**To connect the tablet:**

- Connect the tablet to the serial or USB port of the station, depending on the model you are using.

You may extend this serial or USB connection using the cable extension provided in the DL.CAB-500 cable kit and labeled as DL.CAB-23A.

**NOTE:** You may need to restart Windows for the tablet to be recognized. If using the Linux version of Lustre, starting Xserver will prompt tablet recognition. Press **CTRL+ALT+BACKSPACE** to start the Xserver.

## Connecting the Slave Renderer to a Lustre Workstation

The Slave Renderer is available for the Master Station, the Lustre Station, and the Lustre HD Station. Although the Slave Renderer is connected using a network connection, a higher Category 6 grade cable is needed to accommodate the data that is transmitted.

For information on configuring the IP addresses of the network ports that connect the two workstations, see the *Autodesk Lustre 2008 Software Installation Guide* for your operating system.

**NOTE:** The illustration in this procedure contains a comprehensive IBM IntelliStation Z Pro 6223 backplane, since the on-board network port is in the same location independent of the platform running on the workstation.

**To connect the Slave Renderer:**

1. Connect the Category 6 crossover cable to the on-board network port at the back of the Lustre workstation.
2. Connect the other end of the cable to the 1000Base-T port 1 of the Slave Renderer machine.

The Slave Renderer should be connected as shown in the following diagram.

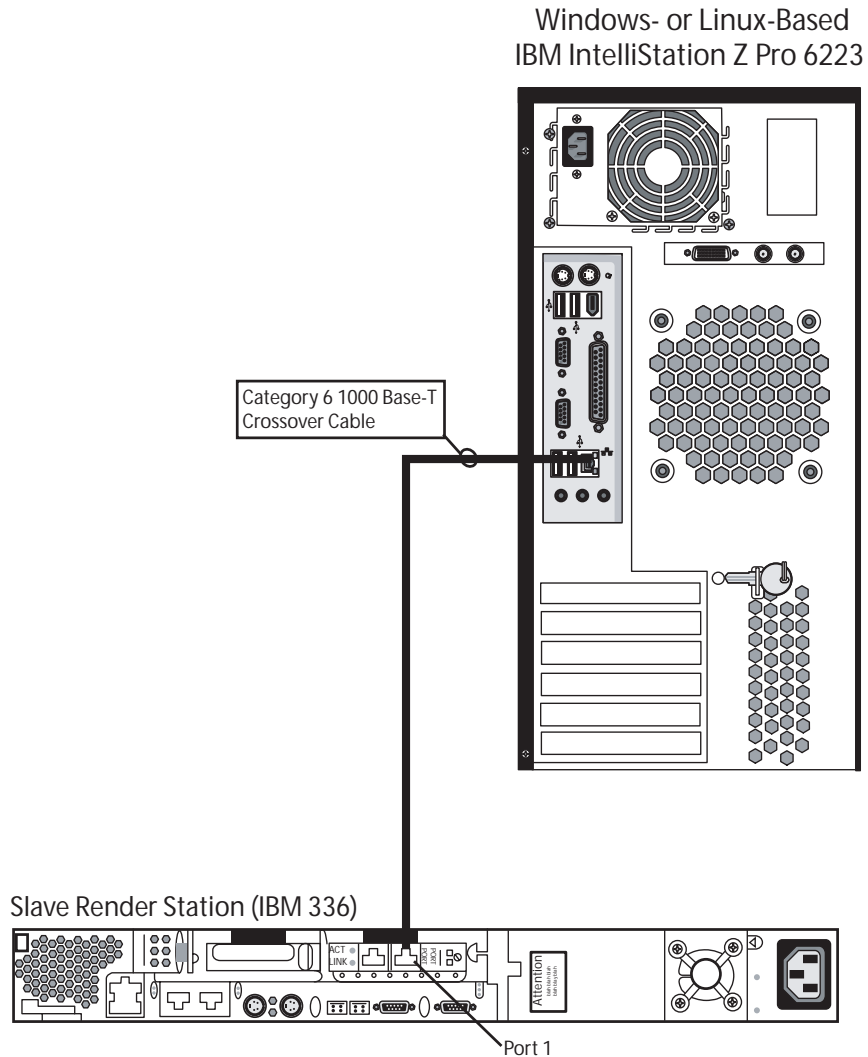

## Connecting Video I/O to a Master or HD Station

Use the Lustre video components to set up video I/O and a broadcast monitor. The only video hardware you must provide are a sync generator, a VTR, and an SD or HD SDI broadcast monitor. The following components are included in your hardware shipment.

**DVS Centaurus board and DVS Breakout Box II (optional)** — The DVS Centaurus board provides video I/O. Use the DVS Breakout Box II for serial control of a VTR or other slave device and LTC output to an audio device.

**NVIDIA Quadro® FX graphics board** — The NVIDIA Quadro FX graphics board provides output to your computer monitor.

**EIZO 24-inch or Sony 21-inch wide screen LCD graphics monitor** — The EIZO and Sony LCD graphics monitors feature a wide screen that makes a 16:9 aspect ratio possible for HD projects. With these monitors, the application runs at a maximum resolution of 1920x1200. For instructions on connecting the graphics monitor, see [“Connecting the Monitor”](#) on page 20.

**Altinex® DA1804NT video distribution amplifier** — The Altinex video distribution amplifier can serve a bi-level (SD) or tri-level (HD) sync signal to up four video hardware devices from a single sync source/generator. It serves the sync signal to the NVIDIA graphics board and the DVS Centaurus board.

## **Video I/O for Real-Time Deliverables**

The following illustrations show the video I/O wiring for FX5500 and FX4000 workstations that can play out to a VTR through the DVS board (real-time deliverables).

3 Connecting System Components

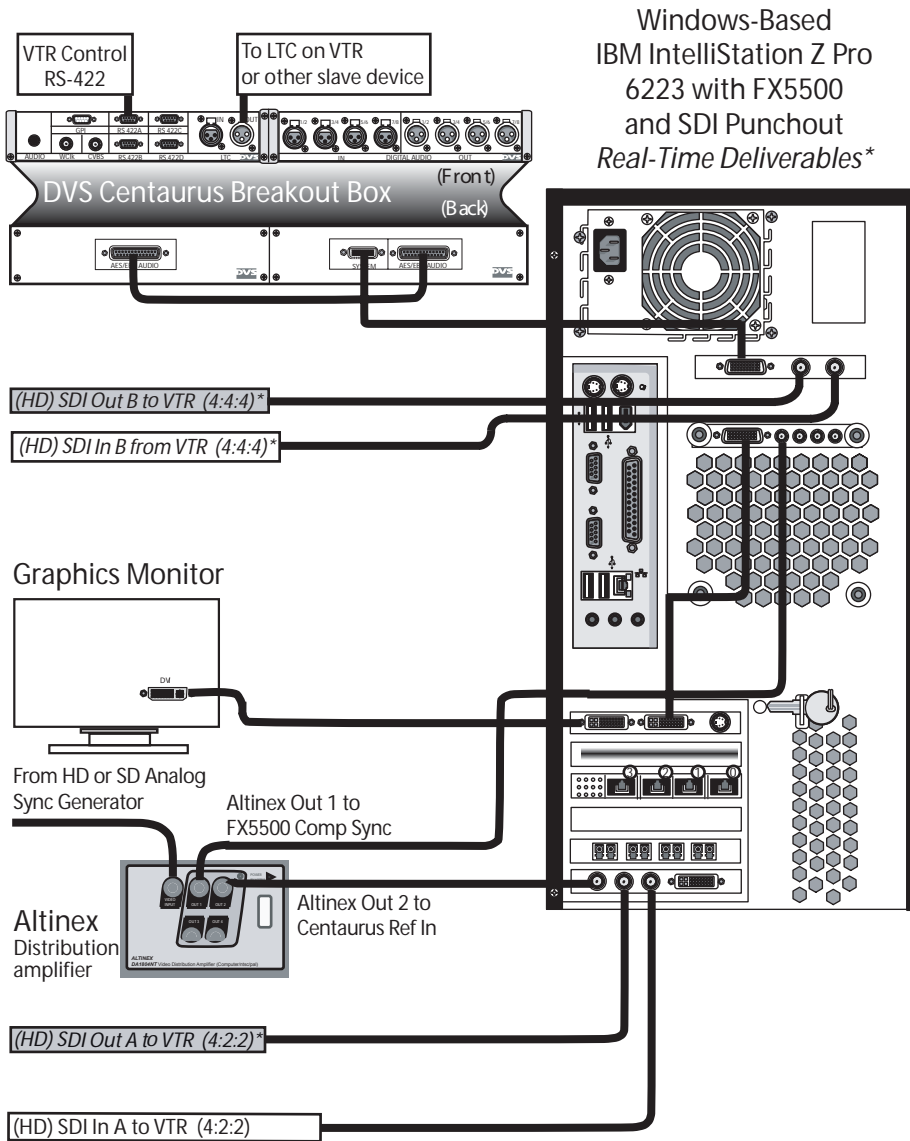

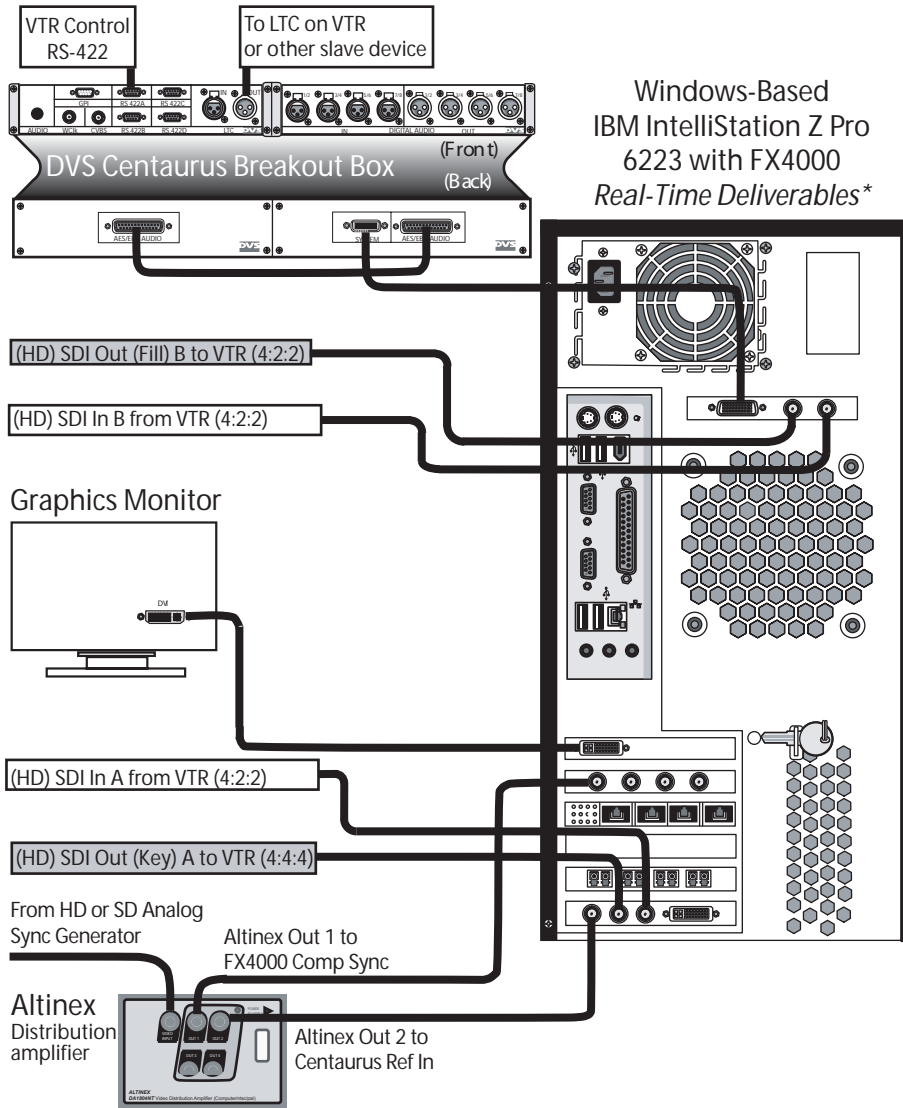

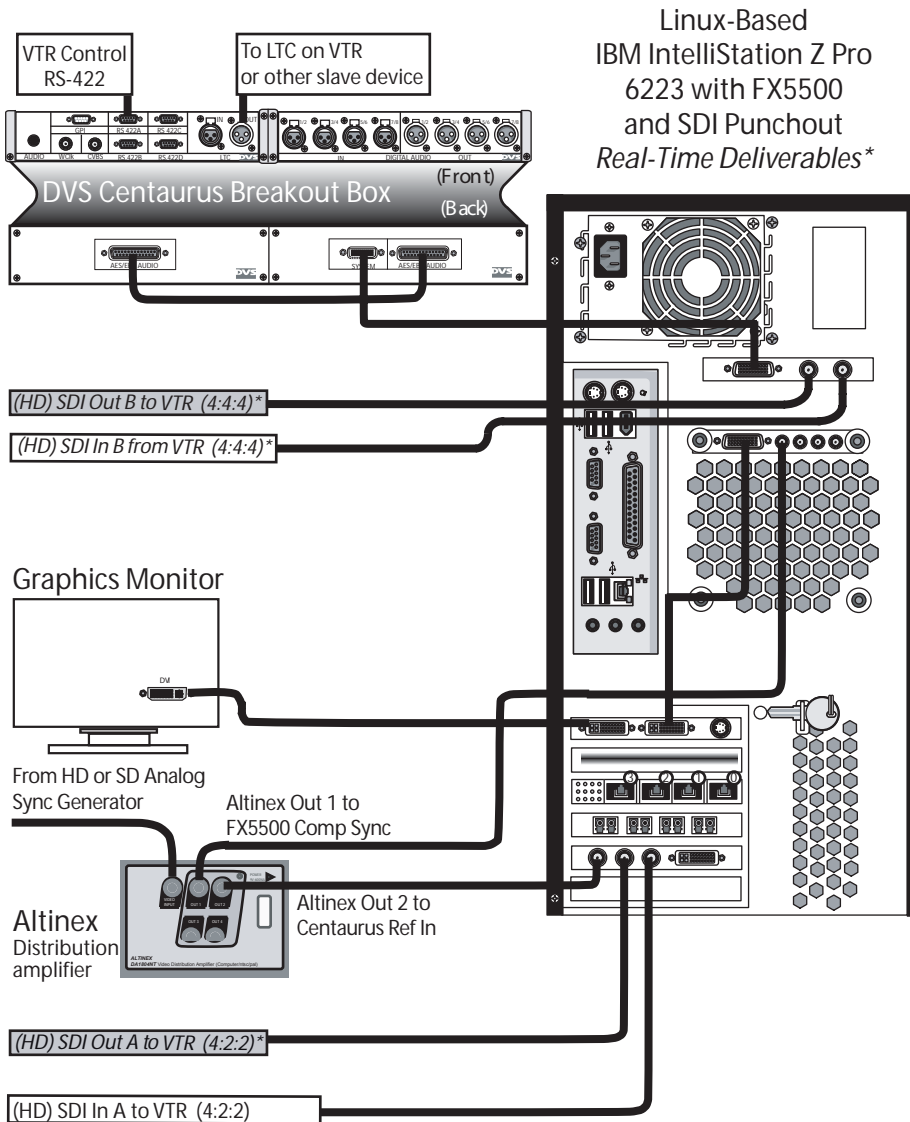

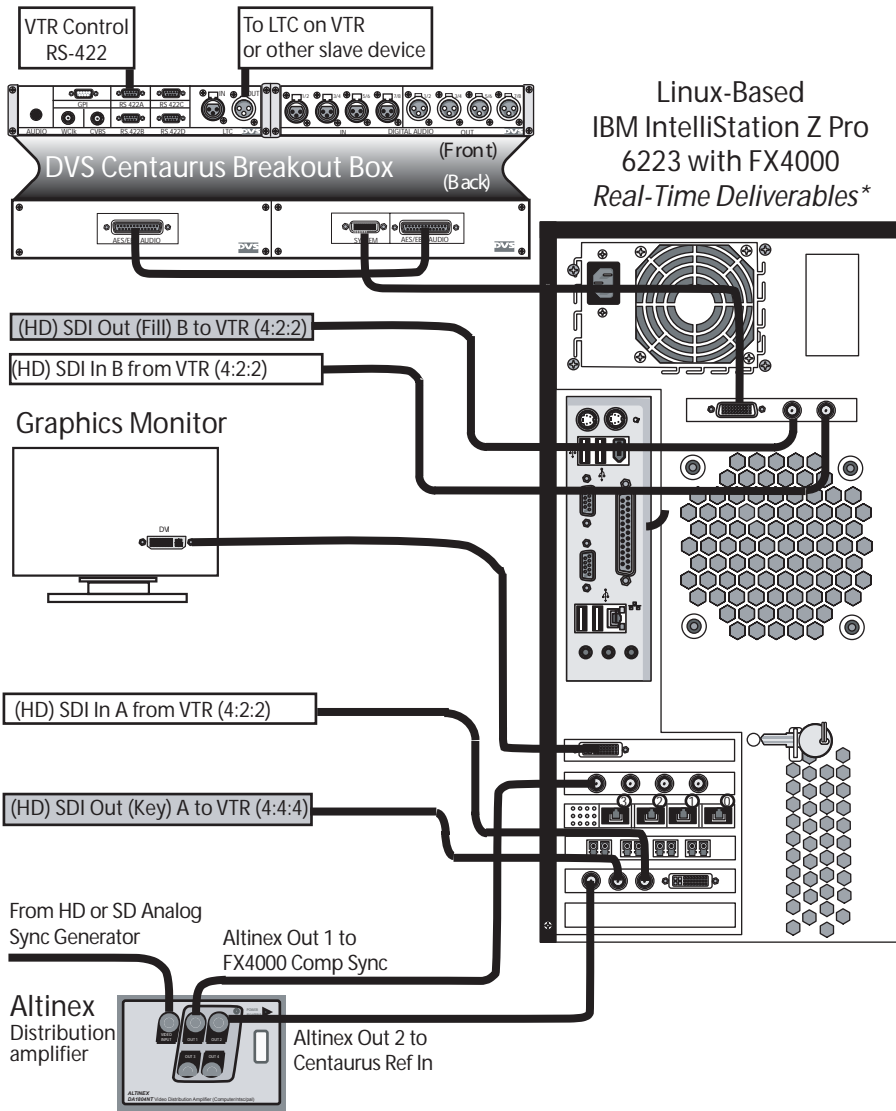

### Video I/O without Real-Time Deliverables

The following illustrations show the video I/O wiring for FX5500 and FX4000 workstations that do not support play out to a VTR through the NVIDIA board (real-time deliverables).

3 Connecting System Components

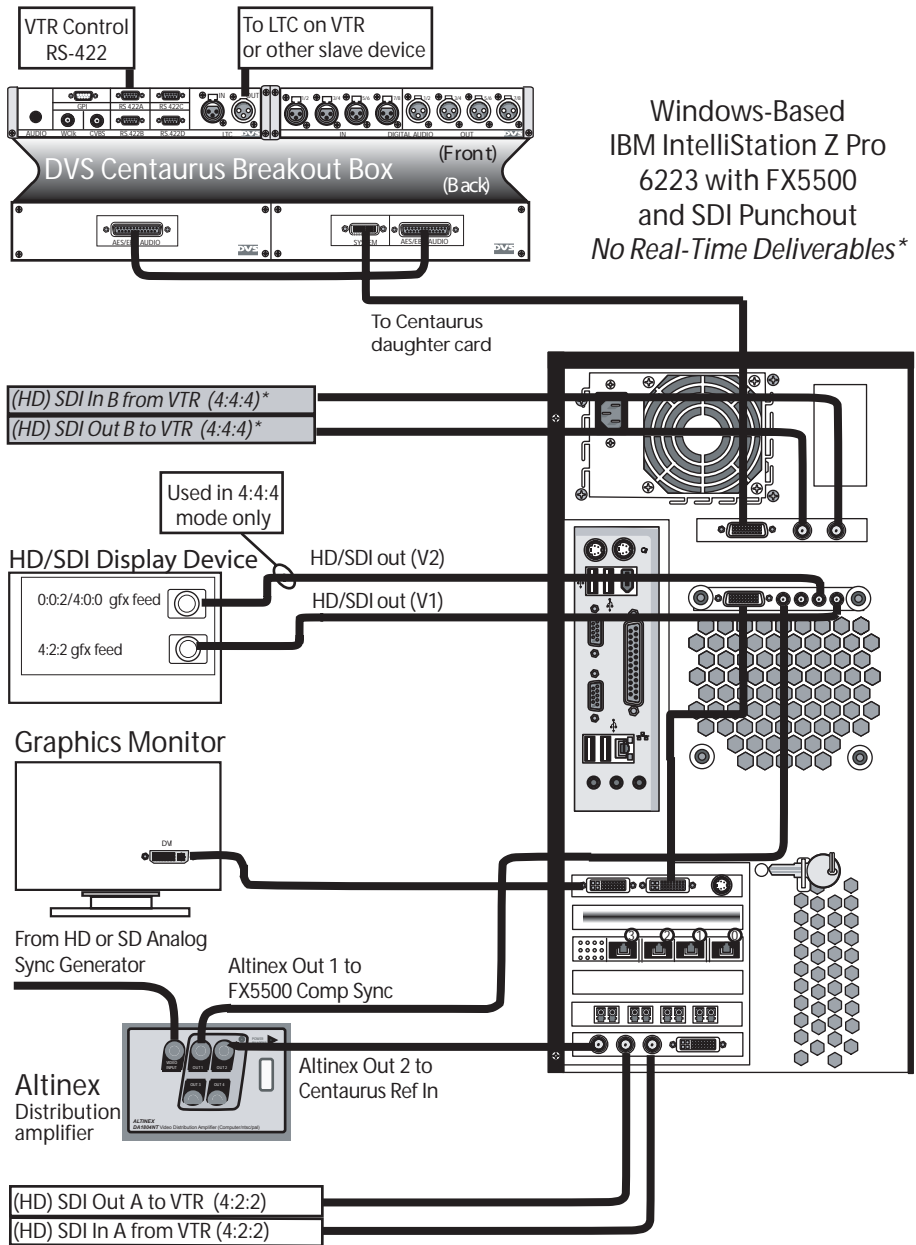

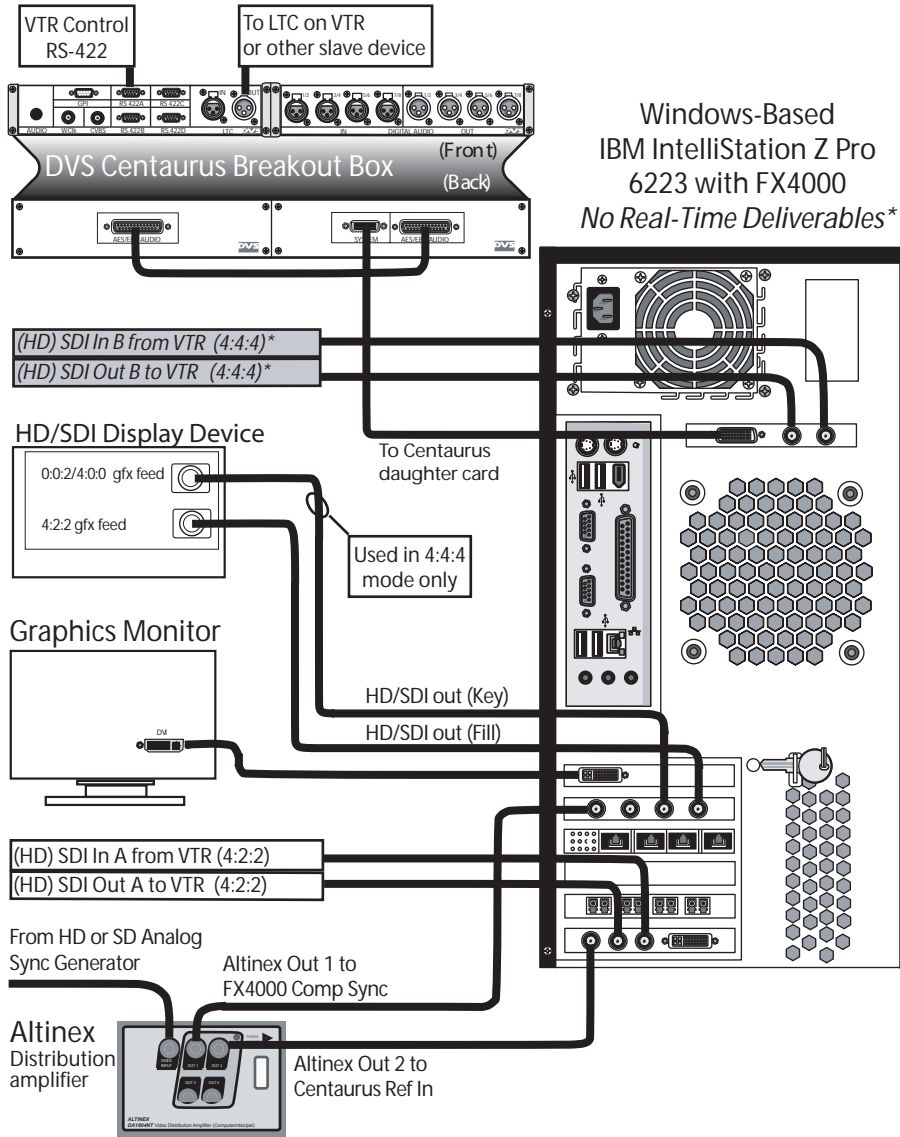

3 Connecting System Components

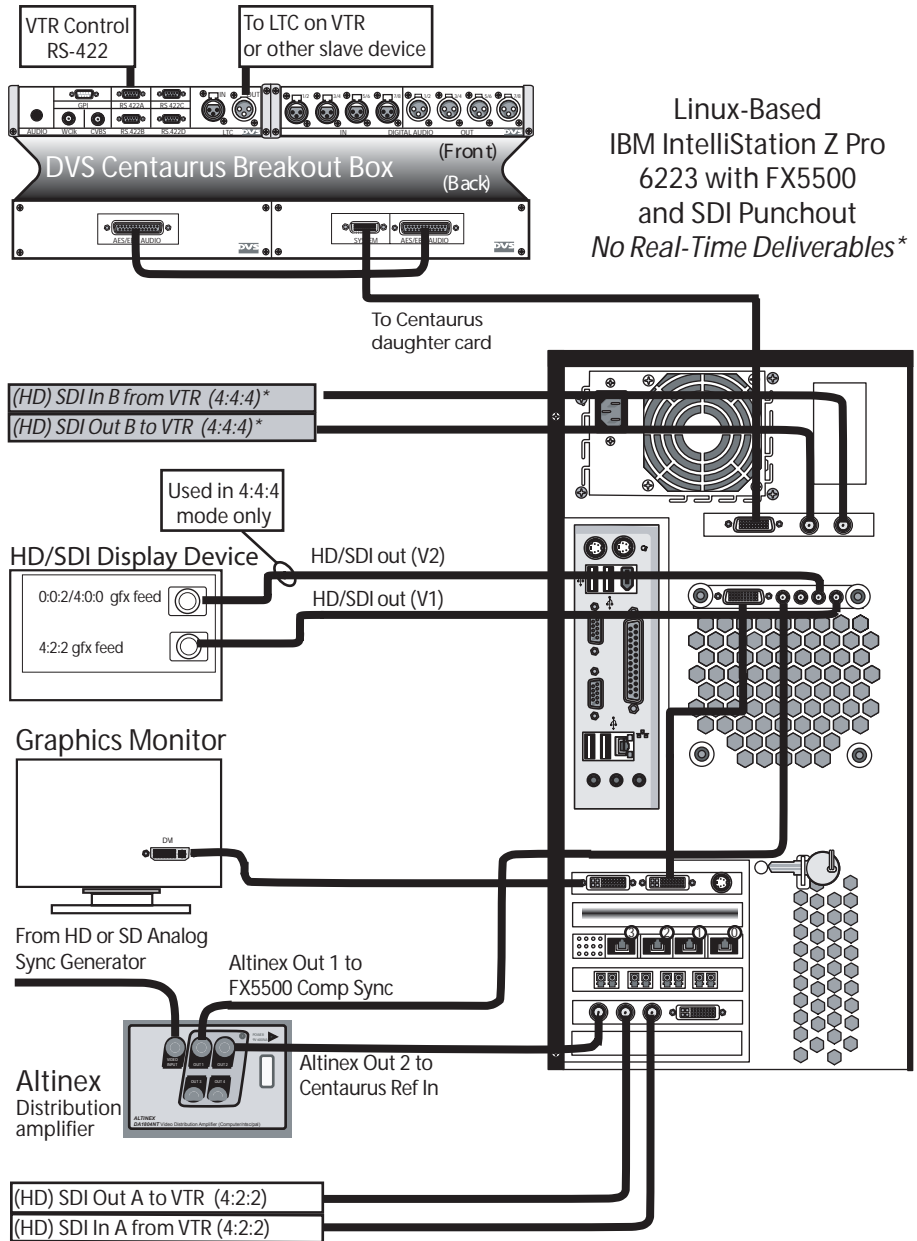

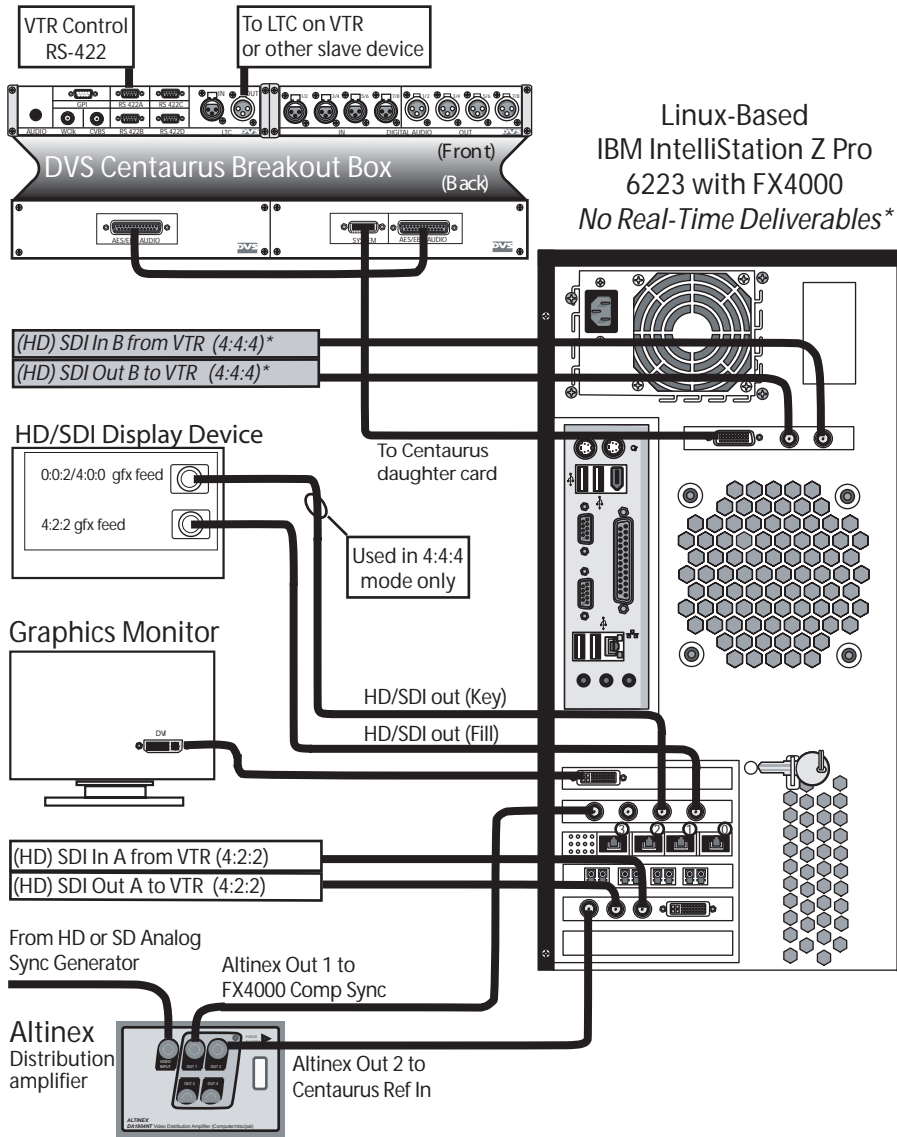

## Connecting to a High-Speed Data Link Device (HSDL)

If you have purchased an HSDL license, you can connect to an HSDL device through the DVS Centaurus.

### 3 Connecting System Components

Connect both the A and B in/out ports on the DVS main board and daughter card to your HSDL device.

# index

## Index

### A

- air conditioning
  - requirements 8
- Autodesk Control Surface
  - assigning IP address 28
  - configuration file 31
  - connecting 26

### B

- BIOS settings
  - fibre channel adapters 21
  - IBM 6223 7
- breakout box
  - connecting 34
- broadcast monitor
  - connecting 34

### C

- configuration guidelines
  - grounding hardware 9
- connecting peripherals
  - workflow 13
- connecting system components
  - workflow 25
- connection diagram
  - IBM 6223 with FX4000 17
  - IBM 6223 with FX5500 and punchout 14
  - IBM 6223 with FX5500 no punchout 16
- control surface
  - Autodesk Control Surface, connecting 26
  - Tangent CP100 31
- conventions, in guide 9

### D

- documentation
  - set of guides 5
- DVSI/O
  - connecting 34

### F

- FX4000
  - upgrading to FX5500 19
- FX5500
  - upgrading from FX4000 19

### G

- graphics monitor
  - connecting 20
- grounding hardware 9
- guide
  - conventions 9

### H

- hardware
  - breakout box 34
  - DVS board 34
  - graphics monitor 20, 34
  - HD/SDI monitor 34
  - HSDL device 43
  - keyboard and mouse 20
  - Slave Renderer 33
  - video distributor amplifier 34
  - VTR 34
- hardware configuration guidelines 6
- HSDL device
  - connecting 43

I

installation  
    overview 1

K

keyboard  
    connecting 20

M

monitor  
    connecting 20  
monitor calibration device  
    connecting 20  
mouse  
    connecting 20

N

network  
    connecting 23

P

peripherals  
    monitor 20  
    monitor calibration device 20  
    mouse and keyboard 20  
    network 23  
    tablet 32  
power  
    requirements 8

Q

QLogic  
    restoring BIOS settings 22  
    verifying BIOS 21

R

real-time deliverables  
    wiring 35

S

SAN  
    connecting 21  
Slave Renderer  
    connecting 33  
Stone Direct

    connecting 21

storage  
    connecting 21

T

tablet  
    connecting 32  
Tangent CP 100  
    connecting 31

V

video distributor amplifier  
    connecting 34  
video I/O connections  
    wiring 39  
    wiring for real-time deliverables 35  
VTR  
    connecting 34  
    wiring for real-time deliverables 35