

# **AutoCAD® Civil 3D® 2014**

## **“Country Kit Danmark”**

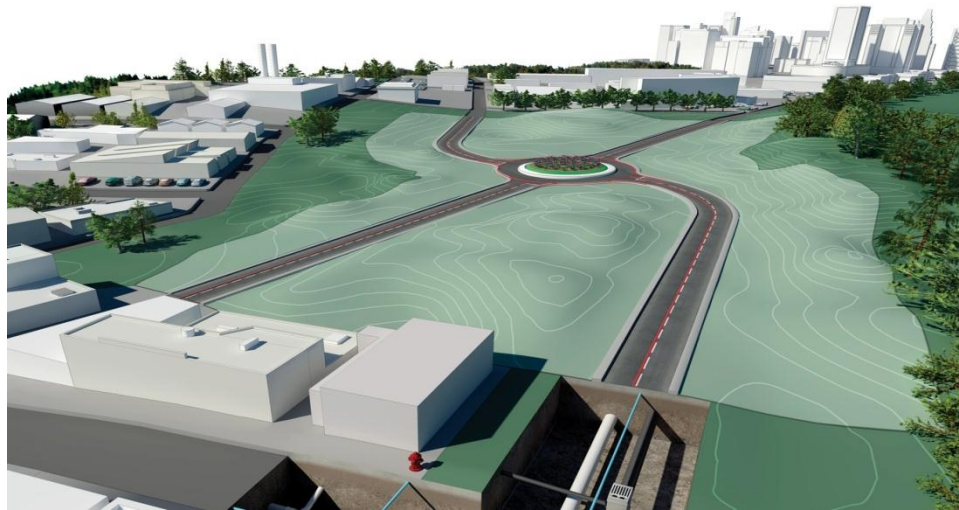

Formålet med dette dokument:

At beskrive generelle indstillinger af AutoCAD Civil 3D 2014 Country Kit for Danmark

## Indholdsfortegnelse

1	Generelt.....	4
1.1	Introduktion.....	4
1.2	indledning.....	4
2	Tekst.....	7
3	Skravering.....	8
4	Lag.....	9
5	Rapporter.....	12
6	Tegningsindstillinger.....	13
6.1	Object Layers.....	13
6.2	Ambient Settings.....	16
7	Objekt stilarter.....	22
7.1	Multi-purpose Styles.....	22
7.2	Points.....	29
7.3	Point Clouds.....	31
7.4	Surfaces.....	34
7.5	Parcels.....	45
7.6	Grading.....	48
7.7	Alignments.....	51
7.8	Profiles.....	57
7.8	Superelevation Views.....	67
7.9	Sections.....	67
7.10	Pipe Networks.....	69
7.11	Corridors.....	72
7.12	Plan and Profile Sheets.....	81
7.13	Survey.....	82
8	Tool palette(s).....	83
8.1	Tværprofiler.....	83
8.2	Material styles.....	83
8.3	Drawing symbols and (MV) Blocks.....	83
9	Pipe and Structure Catalogs.....	84
9.1	Spildevand.....	84
9.2	Regnvand.....	85
9.3	Fælles.....	86
9.4	Dræn.....	87
9.5	Labels.....	88
9.6	Tabel.....	88
10	Highway design check files - vejregler.....	90
11	Quantity Take Off.....	92
11.1	Introduktion til QTO.....	92
11.2	Indstillinger af QTO.....	92
12	Superelevation standards - overhøjde.....	94

13 Kryds - stilarter, navn og tværprofiler .....96

# 1 Generelt

## 1.1 Introduktion

Dette dokument indeholder oversigt af alle indstillinger, som AutoCAD Civil 3D 2014 Country Kit Danmark består af.

Dette dokument indeholder følgende forkortelser:

- AutoCAD Civil 3D 2014 med Civil 3D
- AutoCAD Civil 3D 2014 Country Kit Danmark med CKD

## 1.2 indledning

CKD består af bl.a. følgende mapper:

- **Template.** Mappe med template, der indeholder danske stilarter til Civil 3D objekter og labels.
- **\_DK Pipes Catalog.** Mappe med Pipes filer, der korresponderer med Parts Lists stilarter fra template.
- **Plan Production.** Mappe med templates, der indeholder indstillinger til Plan Production og udtegnning af tværsnit.
- **Corridor Design Standards.** Mappe med fil, der indeholder indstillinger til superelevation af korridor modeller.
- **Quantities Reports.** Mappe med filer, der indeholder indstillinger til generering af rapporter af mængder for korridor modeller eller som dynamiske tabeller i den aktuelle tegning.
- **Toolbox.** Mappe med filer, der indeholder rapporter, som kan køres fra Toolbox fanen i egenskabsvinduet Toolspace.
- **Assemblies.** Mappe med tegninger, der indeholder assemblies (tværprofiler), der bl.a. kan åbnes fra Tool Palettes, eller som skal indgå i opret af kryds.
- **Pay Item Data.** Mappe med filer, der indeholder indstillinger til rapport af arealer og længder.

Toolspace er Civil 3D's centrale egenskabsvindue, der bruges til styring af Civil 3D stilarter af objekter og tekster. Toolspace består, som udgangspunkt af to faner:

- **Prospector.** Bruges til indstilling af egenskaber, stilarter, m.m. for Civil 3D objekter og tekster.
- **Settings.** Bruges til generel indstilling af stilarter for Civil 3D.

### 1.2.1 Prospector

Ethvert Civil 3D objekt har sin egen stilart, der styrer dets udseende og evt. tekster i tegningen. Det er fra fanen Prospector i Toolspace, at egenskaber, stilarter og kommandoer for alle Civil 3D objekter styres.

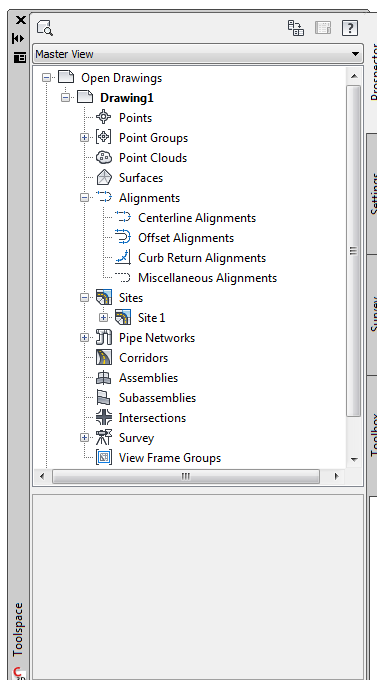

I Civil 3D findes følgende Civil 3D objekttyper:

- Punkter (Points og Point Group)
- Punkt skyer
- Linier (Feature Lines)
- Terrænmodeller (Surfaces)
- Stationeringslinier (Alignments)
- Længde- og vejprofiler (Profiles)
- Vejmodeller og tværprofiler (Corridors og Sections)
- Ledninger (Pipes)
- Arealer (Parcels)
- Anlæg (Grading)
- Landmåling (Survey)
- Plan udtegning (View Frame Groups – Plan Production)
- Kryds (Intersections)

Fra fanen Prospector i Toolspace er det muligt at oprette, kopiere eller rette stilarter for Civil 3D objekter. For Civil 3D objekter gælder herudover, at tekster generes som dynamiske data i det omfang det ønskes. Bemærk, at evt. nye stilarter oprettet fra Prospector ikke automatisk gemmes i template til CKD. Det skal gøres manuelt med Drag and Drop.

### 1.2.2 Settings

Civil 3D objekter får egne stilarter, når de oprettes i tegningen med en Civil 3D kommando. Stilarterne ligger som standard i template til CKD, som det anbefales at start Civil 3D med hver gang for netop at kunne oprette Civil 3D objekter med efter danske forhold fornuftigt udseende.

Indstilling af stilarter sker fra fanen Settings i Toolspace. Her kan nye stilarter oprettes eller tilpasses. Bemærk, at nye eller tilpassede stilarter ikke automatisk gemmes i template til CKD. Det skal gøres manuelt med Drag and Drop.

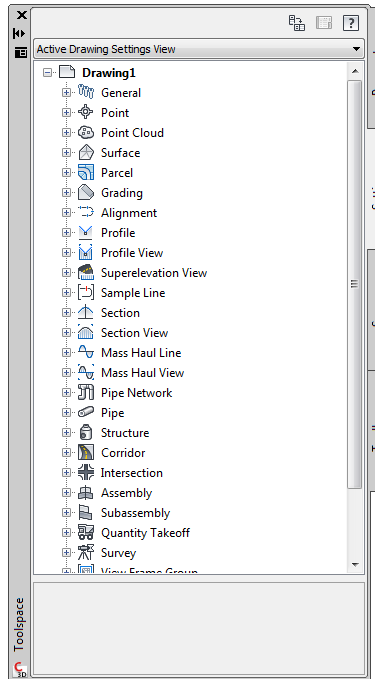

Endvidere, at ikke alle US eller UK stilarter er fjernet. Der findes i Danmark ikke standarder for lag og farver. Med hensyn til lag tildeles Civil 3D objekter standard Civil 3D lag, mens øvrige objekter "lander" i lag 0.

### 1.2.3 Farvevalg

Generelt for farvevalg gælder, at:

- **Rød farve.** Hovedsagligt anvendt til længdeprofiler, tværsnit og massediagram sammen med grå og sorte nuancer.
- **Sort.** Hovedsagligt anvendt til labels og tabeller indsat i tegningen.

På den måde er det hurtigt visuelt at skelne mellem plan, længdeprofiler, tværsnit og evt. dynamiske tabeller indsat i tegningen.

## 2 Tekst

Tabel nedenfor lister anvendt tekst stilart.

Text Style	Description	Font	Plotted Size
Standard		ISOCP	1.5mm > 5.0mm

### 3 Skravering

Tabel nedenfor lister anvendte skraveringstyper.

Hatch Pattern Name	Description	Hatch Pattern File
SOLID	Anvendes til skravering af korridor elementer i Plan, specielle visninger i længdeprofil samt i tværsnit	Template
ANSI31	Anvendes til specielle visninger fx "Hatch" i længdeprofil og tværsnit	Template



## 4 Lag

Tabel nedenfor lister alle anvendte lag og udvalgte indstillinger.

Layer	On	Freeze	Lock	Color	Linetype
0	True	False	False	white	Continuous
A-BLDG	True	False	False	white	Continuous
AHP	True	False	False	white	Continuous
Block amenity light columns	True	False	False	50,50,50	Continuous
Block amenity light glass	True	False	False	200,200,200	Continuous
Block tree concept canopy	True	False	False	white	Continuous
Block tree concept trunk	True	False	False	white	Continuous
C-ALIGN	True	False	False	white	DASHED
C-FLINE	True	False	False	152	Continuous
C-FLINE-PROF	True	False	False	152	Continuous
C-FLINE-SCTN	True	False	False	152	Continuous
C-HLP-KURVETEKST	True	False	False	blue	Continuous
C-PIPE-DRN	True	False	False	green	ACAD_ISO02W100
C-PIPE-FLS	True	False	False	red	DASHED
C-PIPE-RGV	True	False	False	blue	Continuous
C-PIPE-SPV	True	False	False	red	Continuous
C-PIPE-STD	True	False	False	white	Continuous
C-PIPE-STD-LABL	True	False	False	white	Continuous
C-PIPE-STD-PROF	True	False	False	white	Continuous
C-PIPE-STD-SCTN	True	False	False	white	Continuous
C-PIPE-TABL	True	False	False	white	Continuous
C-PROP	True	False	False	white	Continuous
C-PROP-LABL	True	False	False	white	Continuous
C-PROP-LINE	True	False	False	magenta	Continuous
C-PROP-LINE-LABL	True	False	False	magenta	Continuous
C-PROP-TABL	True	False	False	white	Continuous
C-ROAD	True	False	False	white	Continuous
C-ROAD-ALG-LABL	True	False	False	white	Continuous
C-ROAD-ASSM	True	False	False	40	Continuous
C-ROAD-CORR	True	False	False	blue	Continuous
C-ROAD-INTS	True	False	False	white	Continuous
C-ROAD-INTS-LABL	True	False	False	white	Continuous
C-ROAD-LABL	True	False	False	white	Continuous
C-ROAD-PROF	True	False	False	white	Continuous
C-ROAD-PROF-LABL	True	False	False	white	Continuous
C-ROAD-SAMP	True	False	False	white	HIDDEN
C-ROAD-SAMP-LABL	True	False	False	white	HIDDEN

C-ROAD-SCTN	True	False	False	white	Continuous
C-ROAD-SCTN-CORR	True	False	False	blue	Continuous
C-ROAD-SCTN-LABL	True	False	False	white	Continuous
C-ROAD-SCTN-QTO	True	False	False	white	Continuous
C-ROAD-SCTN-SHET	True	False	False	white	Continuous
C-ROAD-SE-VIEW	True	False	False	White	Continuous
C-ROAD-SE-VIEW-TEXT	True	False	False	11	Continuous
C-ROAD-SE-VIEW-TICK	True	False	False	White	Continuous
C-ROAD-SE-VIEW-TITL	True	False	False	11	Continuous
C-ROAD-SE-VIEW-TTBL	True	False	False	Blue	Continuous
C-ROAD-SHAP	True	False	False	Blue	Continuous
C-ROAD-SHAP-PATT	True	False	False	Blue	Continuous
C-ROAD-TABL	True	False	False	White	Continuous
C-ROAD-VC-OBS-AREA	True	False	False	Red	Continuous
C-ROAD-VC-OBS-EYE-PATH	True	False	False	Magenta	Continuous
C-ROAD-VC-OBS-SIGHT-LINES	True	False	False	Red	Continuous
C-ROAD-VC-VIS-EYE-PATH	True	False	False	White	Continuous
C-ROAD-VC-VIS-SIGHT-LINES	True	False	False	71	Continuous
C-STRM-PIPE	True	False	False	white	Continuous
C-STRM-SCTN	True	False	False	white	Continuous
C-STRUCT-STD	True	False	False	white	Continuous
C-STRUCT-STD-LABL	True	False	False	white	Continuous
C-TOPO	True	False	False	white	Continuous
C-TOPO-GRAD	True	False	False	94	Continuous
C-TOPO-GRAD-FLIN	True	False	False	152	Continuous
C-TOPO-LABL	True	False	False	white	Continuous
C-TOPO-TABL	True	False	False	white	Continuous
DEFPOINTS	True	False	False	white	Continuous
Hjälplinje Nivåkurvtext	True	False	False	blue	Continuous
NOT-TABELL	True	False	False	green	Continuous
NOT-TABELL-RAM	True	False	False	green	Continuous
NOT-TABELL-RASTER	True	False	False	green	Continuous
NOT-TABELL-TEXT	True	False	False	green	Continuous
NOT-TABELL-TITEL	True	False	False	green	Continuous
PROFIL-DIAG	True	False	False	red	Continuous
PROFIL-RAM	True	False	False	red	Continuous
PROFIL-TEXT	True	False	False	red	Continuous
PROFIL-TICK	True	False	False	red	Continuous
PROFIL-TITL	True	False	False	red	Continuous
TERRAENKOTEPKT	True	False	False	white	Continuous
V-NODE	True	False	False	red	Continuous
V-NODE-TABL	True	False	False	white	Continuous
V-SITE-SCAN	True	False	False	White	Continuous
VAG-SHAPE-2D	True	False	False	red	Continuous

VAG-SHAPE-3D	True	False	False	8	Continuous
VAG-SHAPE-RASTER	True	False	False	31	Continuous

## 5 Rapporter

Tabel nedenfor lister alle Civil 3D DK rapporter.

<i>Report Name</i>	<i>Description</i>	<i>Sample File Name</i>	<i>Priority</i>
<i>Alignment &gt; Kurver</i>	Rapport på dansk med liste af kurver for valgt linjeføring		
<i>Alignment &gt; Station og kurver</i>	Rapport på dansk med liste af stationer og kurver for valgt linjeføring		
<i>Parcel &gt; Arealer</i>	Rapport på dansk med liste af parcel arealer		
<i>Parcel &gt; Arealer til Excel...</i>	Excel regneark af parcel arealer		
<i>Points &gt; Punkter</i>	Rapport på dansk med liste af kotepunkter		
<i>Points &gt; Punkter til Excel...</i>	Excel regneark af kotepunkter		
<i>Profile &gt; PVI stationer</i>	Rapport på dansk med liste af PVI punkter		
<i>Profile &gt; Ver. Profiler til Excel...</i>	Excel regneark af vertikale punkter		
<i>Ledningsnetværk &gt; Ledninger</i>	Rapport på dansk med liste af ledninger		
<i>Ledningsnetværk &gt; Komponenter</i>	Rapport på dansk med lister af komponenter		
<i>Ledningsnetværk &gt; Ledninger og komponenter</i>	Rapport på dansk med lister af ledninger og komponenter		
<i>Ledningsnetværk &gt; Komponenter til Excel...</i>	Excel regneark af komponenter		
<i>Surface &gt; Information</i>	Rapport på dansk af grundlæggende data for surface		
<i>Surface &gt; Punkter til Excel...</i>	Excel regneark af punkter, som definerer surface		

## 6 Tegningsindstillinger

### 6.1 Object Layers

Tabel nedenfor lister alle Civil 3D objekt lag.

Object	Default Layer
Object	Layer
Alignment	C-ROAD
Alignment-Labeling	C-ROAD-LABL
Alignment Table	C-ROAD-TABL
Assembly	C-ROAD-ASSM
Building Site	A-BLDG
Corridor	C-ROAD-CORR
Corridor Section	C-ROAD-SCTN-CORR
Feature Line	C-FLINE
General Note Label	0
General Segment Label	0
Grading	C-TOPO-GRAD
Grading-Labeling	C-TOPO-LABL
Grid Surface	C-TOPO
Grid Surface-Labeling	C-TOPO-LABL
Interference	0
Intersection	C-ROAD-INTS
Intersection-Labeling	C-ROAD-INTS-LABL
Mass Haul Line	0
Mass Haul View	0
Match Line	0
Match Line-Labeling	0
Material Section	0
Material Table	0
Parcel	C-PROP
Parcel-Labeling	C-PROP-LABL
Parcel Segment	C-PROP-LINE
Parcel Segment-Labeling	C-PROP-LINE-LABL
Parcel Table	C-PROP-TABL
Pipe	C-PIPE-STD
Pipe-Labeling	C-PIPE-STD-LABL

Pipe and Structure Table	C-PIPE-TABL
Pipe Network Section	C-PIPE-STD-SCTN
Pipe or Structure Profile	C-PIPE-STD-PROF
Point Table	V-NODE-TABL
Profile	C-ROAD-PROF
Profile-Labeling	C-ROAD-PROF-LABL
Profile View	C-ROAD-PROF
Profile View-Labeling	C-ROAD-PROF-LABL
Sample Line	C-ROAD-SAMP
Sample Line-Labeling	C-ROAD-SAMP-LABL
Section	C-ROAD-SCTN
Section-Labeling	C-ROAD-SCTN-LABL
Section View	C-ROAD-SCTN
Section View-Labeling	C-ROAD-SCTN-LABL
Section View Quantity Takeoff Table	C-ROAD-SCTN-QTO
Sheet	C-ROAD-SCTN-SHET
Structure	C-STRUCT-STD
Structure-Labeling	C-STRUCT-STD-LABL
Superelevation View	C-ROAD-SE-VIEW
Subassembly	C-ROAD-ASSM
Surface Legend Table	C-TOPO-TABL
Survey Figure	0
Survey Network	0
Tin Surface	C-TOPO
Tin Surface-Labeling	C-TOPO-LABL
View Frame	0

### 6.1.1 Edit Drawing Settings...

Civil 3D objekt lag indstilles i Edit Drawing Settings... Figur nedenfor viser, hvor disse indstillinger findes.

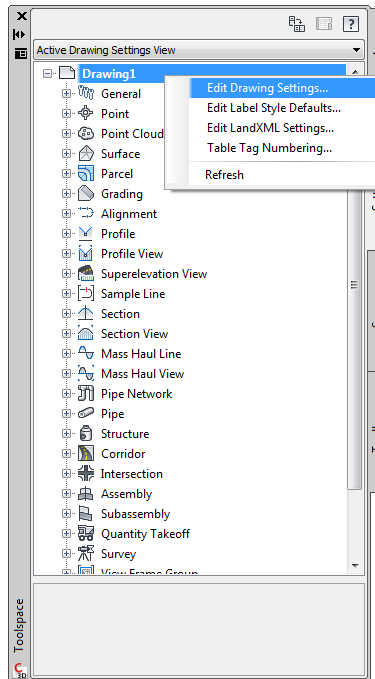

### 6.1.2 Object Layers...

Figur nedenfor viser faneblad Object Layers, hvor indstillinger for Civil 3D objekt lag tilpasses.

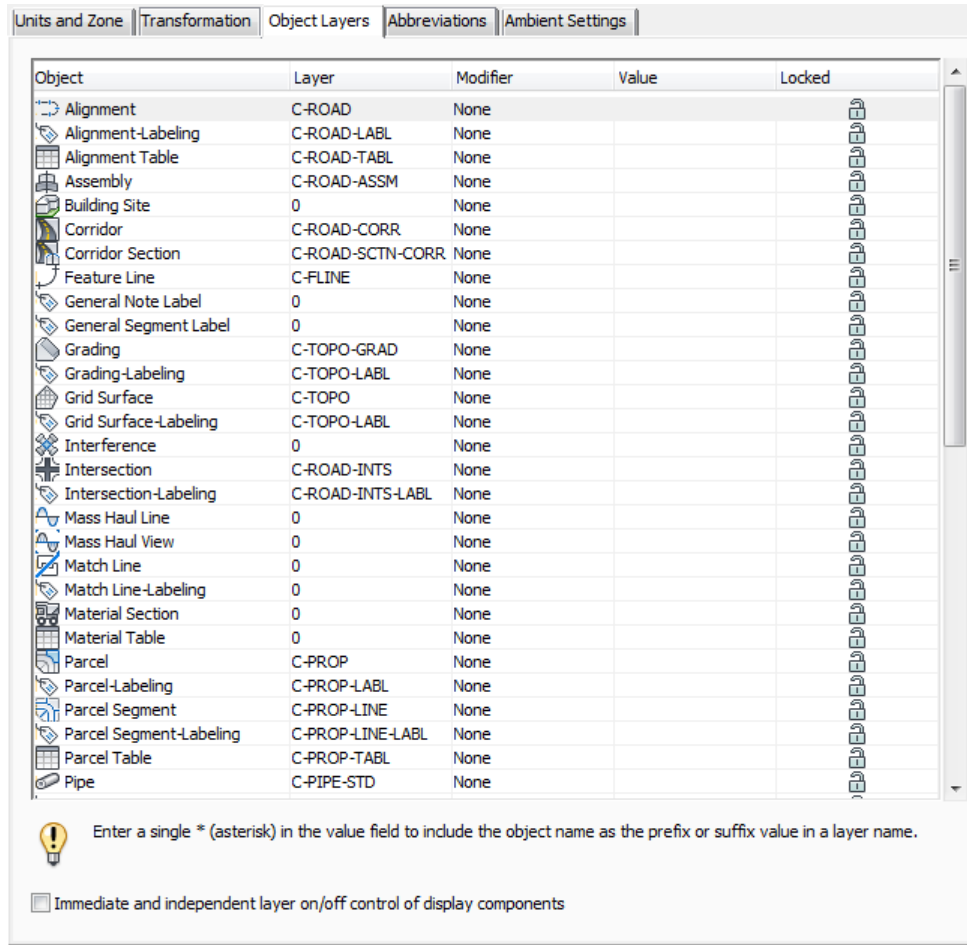

**6.2 Ambient Settings**

Tabel nedenfor lister værdier for alle Civil 3D enheder.

Property	Value
<b>General</b>	
Plotted Unit Display Type	decimal
Set AutoCAD Units	no
Save Command Changes to Settings	no
Show Event Viewer	yes
Show Tooltips	yes
Imperial to Metric conversion	Use International Foot
New Entity Tooltip State	on
Driving Direction	Right Side of the Road
Drawing Unit	meter
Drawing Scale	0.500
Scale Inserted Objects	yes
Independent Layer On	no



Labeling	Labeling Prompt Method	Command Line
Unitless	Precision	3
	Rounding	round normal
	Sign	sign negative '-'
Distance	Unit	meter
	Precision	3
	Rounding	round normal
	Sign	sign negative '-'
Dimension	Unit	millimeter
	Precision	3
	Rounding	round normal
	Sign	sign negative '-'
Coordinate	Unit	meter
	Precision	3
	Rounding	round normal
	Sign	sign negative '-'
Grid Coordinate	Unit	meter
	Precision	4
	Rounding	round normal
	Sign	sign negative '-'
Elevation	Unit	meter
	Precision	3
	Rounding	round normal
	Sign	sign negative '-'
Area	Unit	square meter
	Precision	2
	Rounding	round normal
	Sign	sign negative '-'

Volume	Unit	cubic meter
	Precision	2
	Rounding	round normal
	Sign	sign negative '-'
Speed	Unit	kilometer/hr.
	Precision	0
	Rounding	round normal
	Sign	sign negative '-'
Angle	Unit	grad
	Precision	3
	Rounding	round normal
	Format	decimal
	Sign	sign negative '-'
	Drop Decimal for Whole Numbers	no
	Drop Leading Zeros for Degrees	yes
Direction	Unit	grad
	Precision	3
	Rounding	round normal
	Format	decimal
	Direction	short name
	Capitalization	upper case
	Sign	sign negative '-'
	Measurement Type	North Azimuth
	Bearing Quadrant	1 - NE
	Drop Decimal for Whole Numbers	no
	Drop Leading Zeros for Degrees	yes
	Lat Long	Unit
Precision		3
Rounding		round normal
Format		DD° MM' SS.SS" (spaced)
Direction		prefix short name
Capitalization		upper case
Drop Decimal for Whole Numbers		no

	Drop Leading Zeros for Degrees	yes
Grade	Precision	3
	Rounding	round normal
	Format	percent
	Sign	sign negative '-'
Slope	Precision	3
	Rounding	round normal
	Format	rise:run
	Sign	sign negative '-'
Grade/Slope	Precision	2
	Rounding	round normal
	Format	rise:run
	Sign	sign negative '-'
Station	Unit	meter
	Format	station format
	Precision	3
	Rounding	round normal
	Sign	sign negative '-'
	Station Delimiter Character	plus sign '+'
	Station Delimiter Position	1+000
	Drop Decimal for Whole Numbers	yes
	Drop Leading Zeros Right of Station Character	yes
	Minimum Display Width	0
	Transparent Commands	Prompt for 3D Points
Prompt for Y before X		false
Prompt for Easting then Northing		false
Prompt for Longitude then Latitude		false

### 6.2.1 Edit Drawing Settings...

Civil 3D enheder indstilles i Edit Drawing Settings... Figur nedenfor viser, hvor disse indstillinger findes.

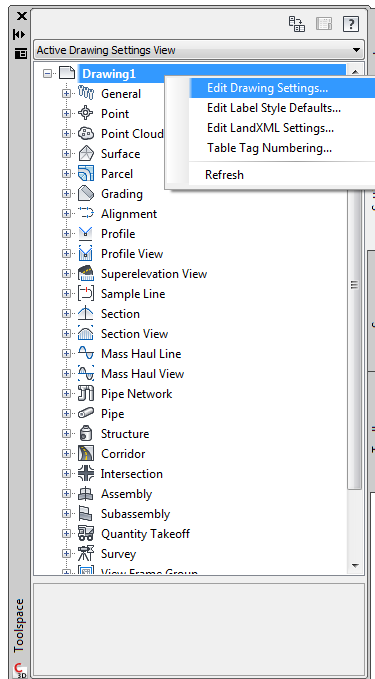

### 6.2.2 Ambient Settings...

Figur nedenfor viser faneblad Ambient Settings, hvor indstillinger for Civil 3D enheder tilpasses.

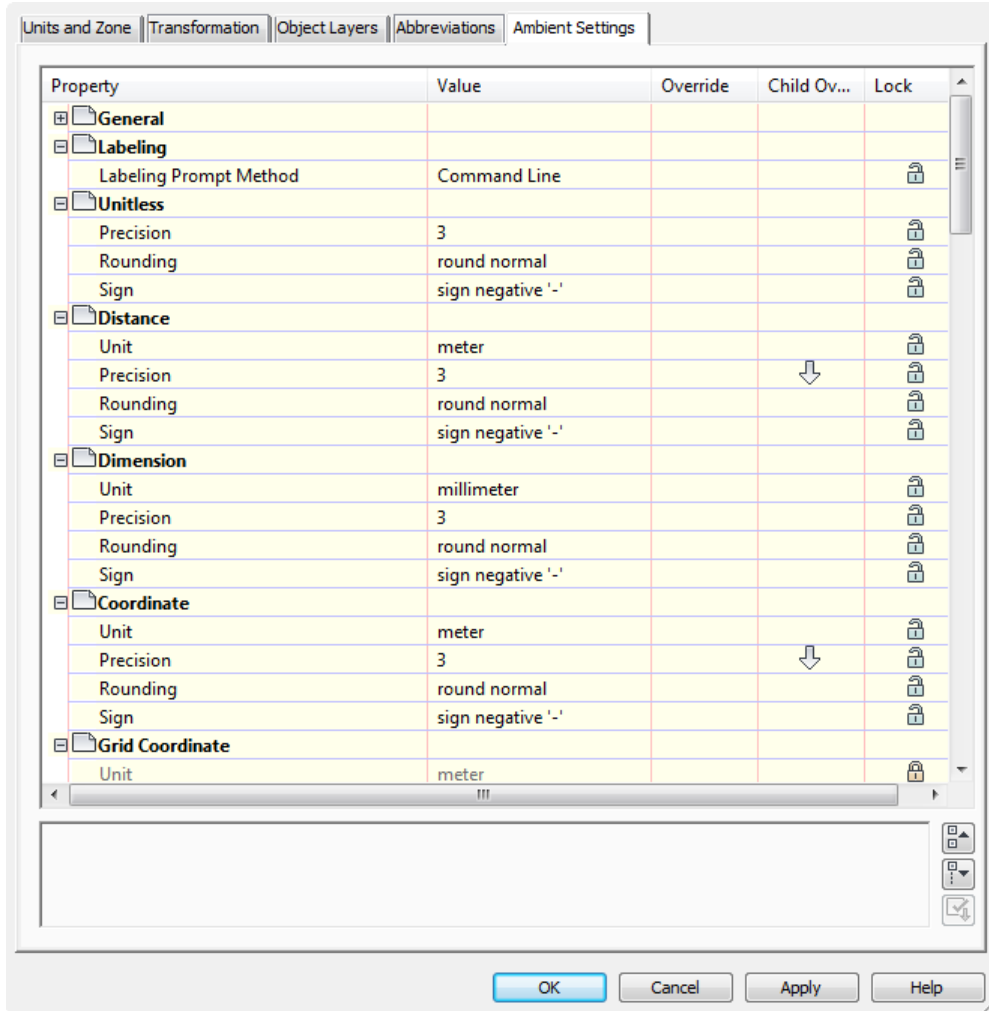

## 7 Objekt stilarter

Alle Civil 3D objekt stilarter findes i template <\_AutoCAD Civil 3D 2014 DK.dwt>. Alle Civil 3D objekter, hvor der ikke er sket tilpasning af stilart, er angivet med <Ingen>.

### 7.1 Multi-purpose Styles

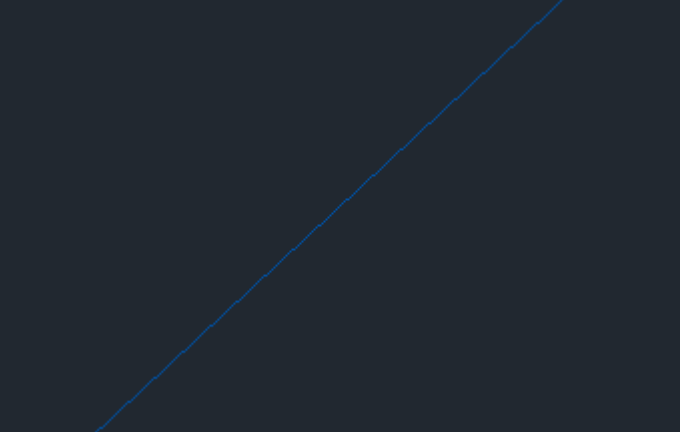
Feature Line Styles	Description	Screen grab / DWF / DWG	Default
Basis Feature Line	Feature Line med farve 152 (blålig) og med linetype Continuous		Ja

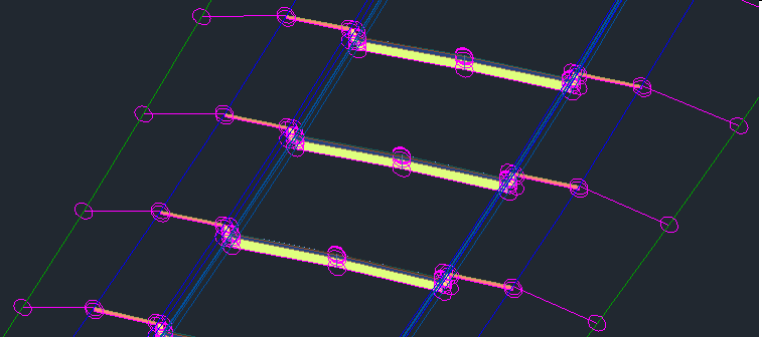
Code Set Styles	Description	Screen grab / DWF / DWG	Default
Alle koder	Viser alle korridor elementer inklusiv markører		

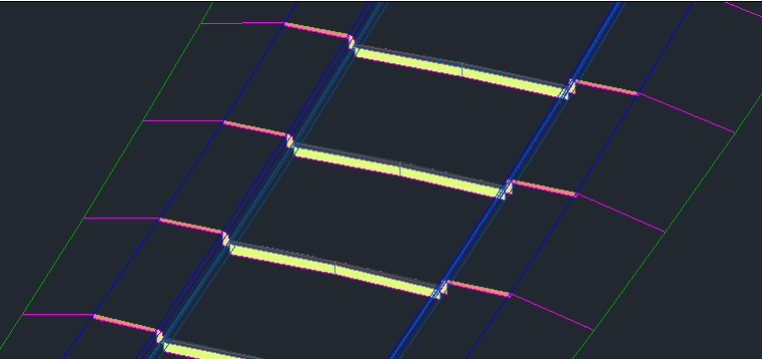
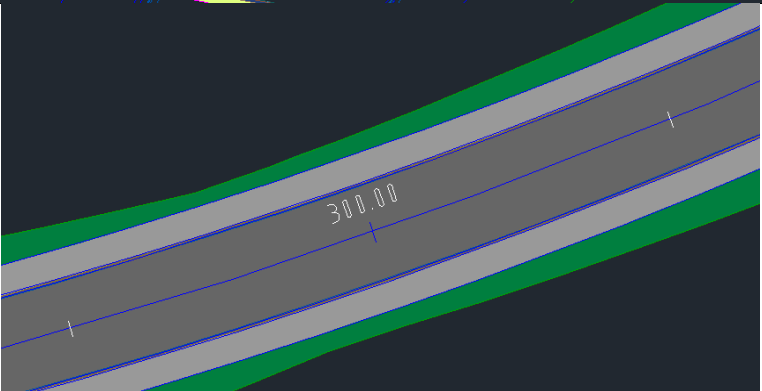
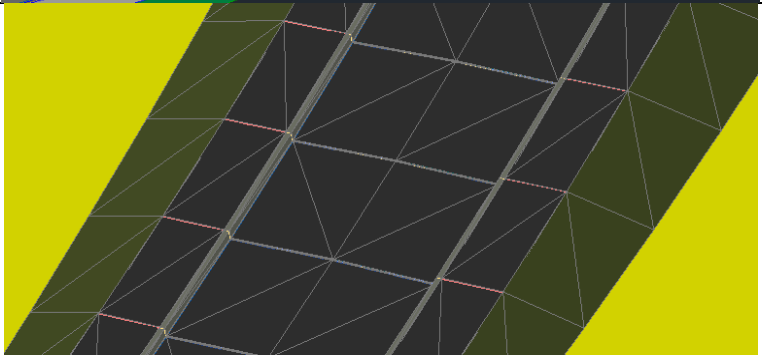
<p>Uden markør</p>	<p>Viser alle korridor elementer uden markører</p>		<p>Ja</p>
<p>Skravering</p>	<p>Viser alle korridor elementer uden markører med skravering ved visning i Top View</p>		
<p>Visualisering</p>	<p>Viser alle korridor elementer uden markører materialer til visualisering ved isometrisk visning og visual styles forskellig fra 2D Wireframe</p>		

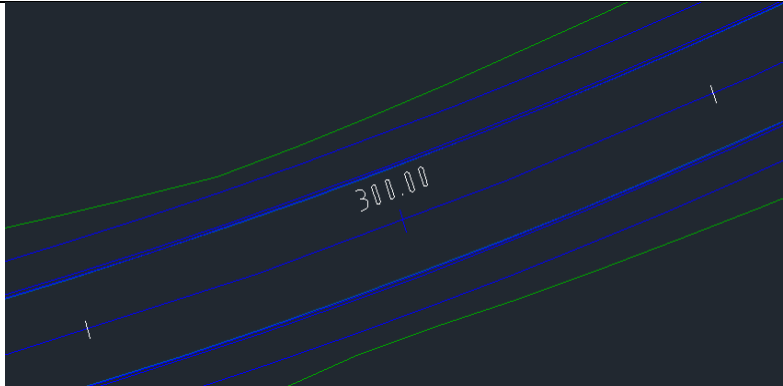
<p>Plot</p>	<p>Viser alle korridor elementer uden tværprofiler til brug for plot fra model og isometrisk visning.</p>		
-------------	---	---	--

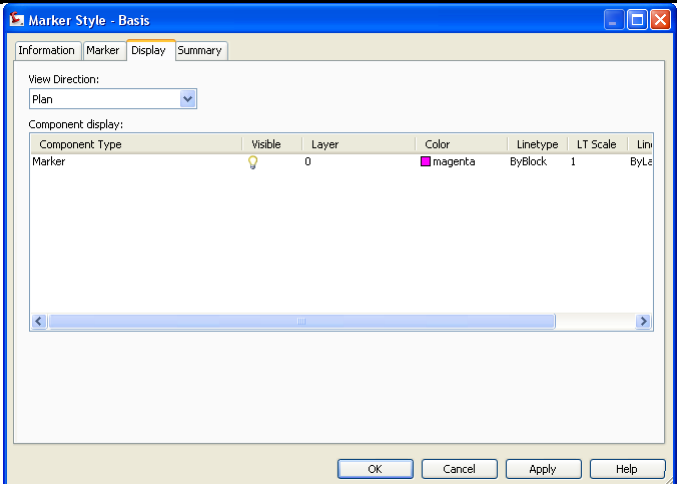
Marker Styles	Description	Screen grab / DWF / DWG	Default
<p>Basis</p>	<p>Point (rund ring) med magenta farve</p>		<p>Ja</p>

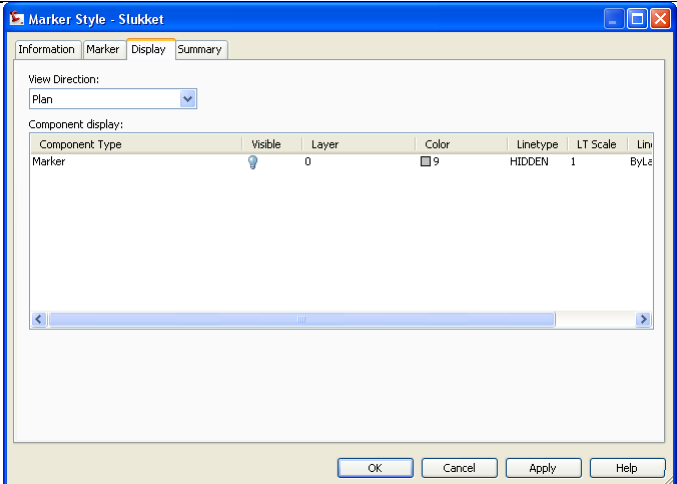

Slukket	Ingen markør		
---------	--------------	---	--

Link Styles	Description	Screen grab / DWF / DWG	Default
<Ingen>			

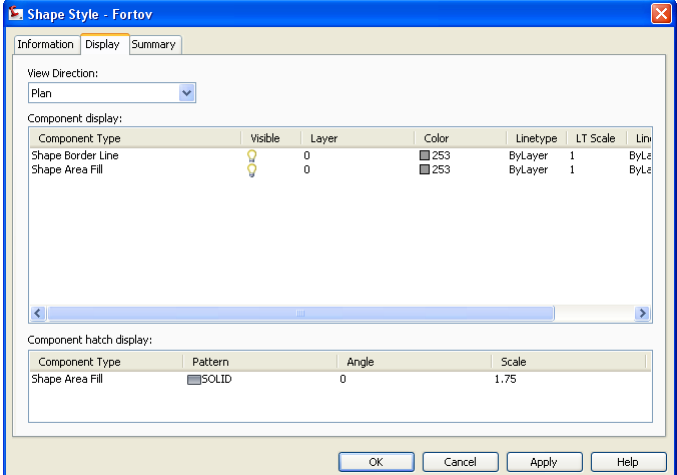
Shape Styles	Description	Screen grab / DWF / DWG	Default
Fortov	Skravering af fortov i forbindelse med Code Set Style Skravering		Ja

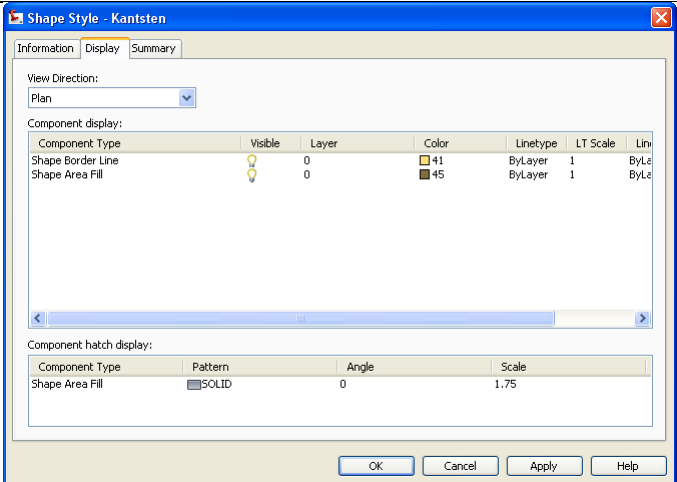
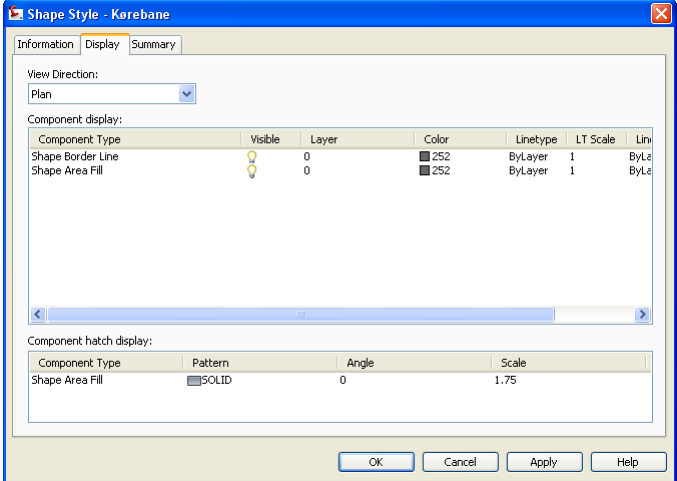
<p>Kantsten</p>	<p>Skravering af kantsten i forbindelse med Code Set Style Skravering</p>		<p>Ja</p>
<p>Kørebane</p>	<p>Skravering af kørebane i forbindelse med Code Set Style Skravering</p>		<p>Ja</p>

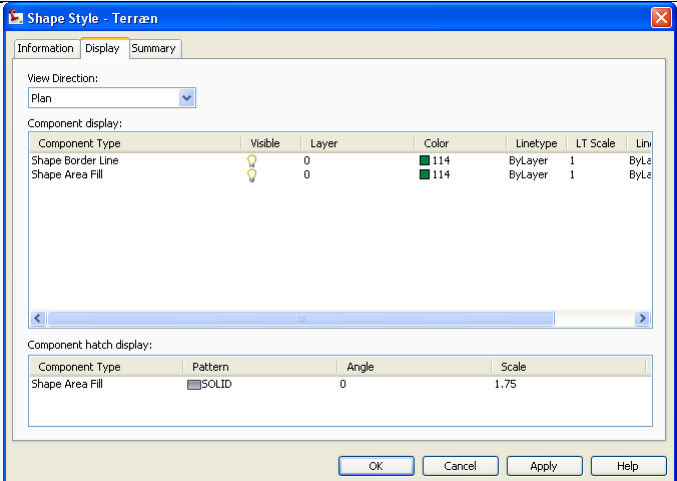
<p>Terræn</p>	<p>Skravering af terræn (cut og fill) mellem korridor model og eksisterende terræn i forbindelse med Code Set Style Skravering</p>		<p>Ja</p>
---------------	--	---	-----------

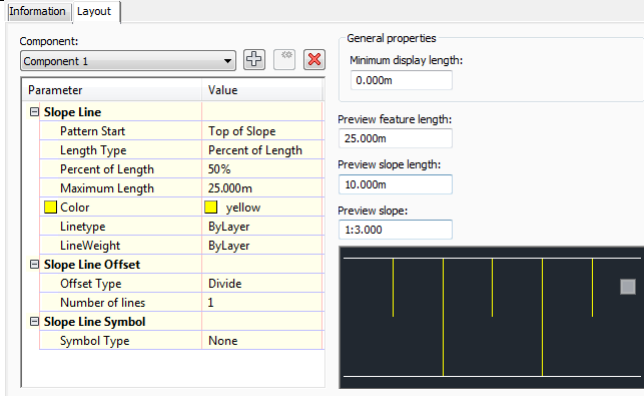
Slope Pattern Style	Description	Screen grab / DWF / DWG	Default
<p>Skråningssignatur</p>	<p>Skråninger vises med gul farve</p>		<p>Ja</p>

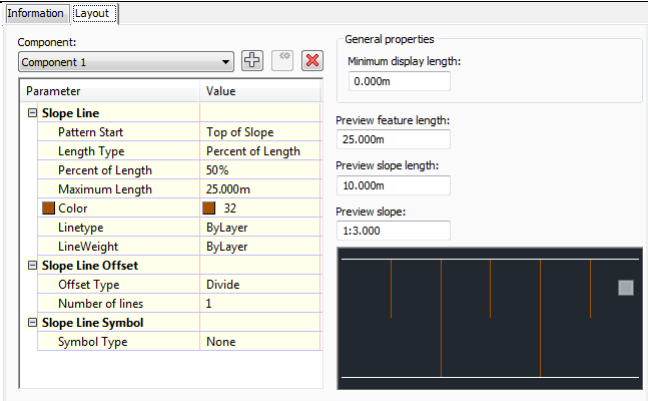
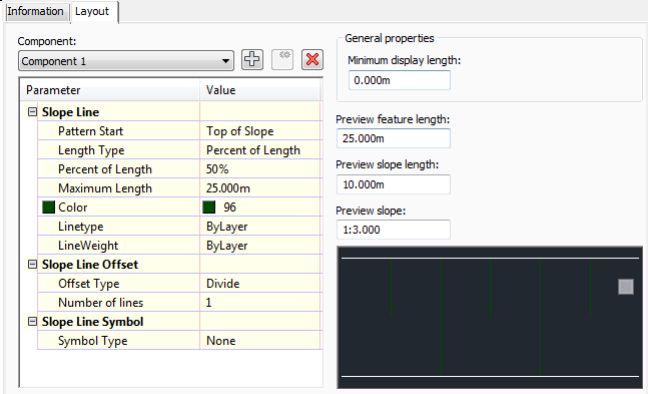
<p>Skråningssignatur (Cut)</p>	<p>Skråninger vises med farven 32</p>		
<p>Skråningssignatur (Fill)</p>	<p>Skråninger vises med farven 96</p>		

Multi-purpose Label Styles	Description	Screen grab / DWF / DWG	Default
Note			
<Ingen>			
Line			
<Ingen>			
Curve			
<Ingen>			
Marker			
<Ingen>			
Link			
<Ingen>			



Shape			
<Ingen>			

Projection Styles	Description	Screen grab / DWF / DWG	Default
<Ingen>			Ja

**7.2 Points**

User Defined Attribute Classifications	Description	Screen grab / DWF / DWG	Default
<Ingen>			

Point Styles	Description	Screen grab / DWF / DWG	Default
<Ingen>			

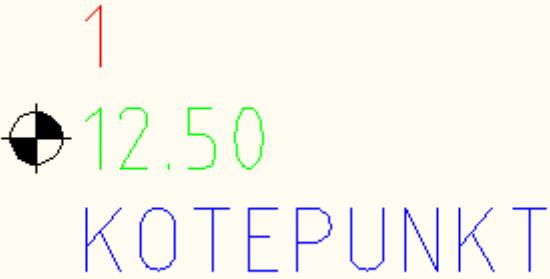

Point Label Styles	Description	Screen grab / DWF / DWG	Default
Kode	Viser kun kode (Raw Description)		
Kote	Viser kun kote (Point Elevation)		
Nummer	Viser kun nummer (Point Number)		

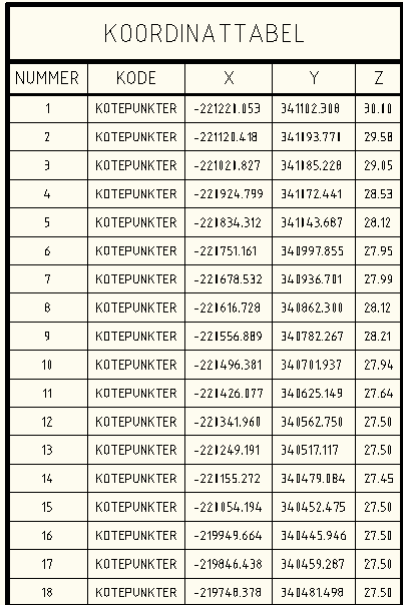

<p>Nummer m. kode og kote</p>	<p>Viser nummer, kote og kote</p>		
-------------------------------	-----------------------------------	---	--

Description Key Sets	Description	Screen grab / DWF / DWG	Default																								
<p>Nummer</p>	<p>Eksempel på Description key Sets</p>	<table border="1"> <thead> <tr> <th>Code</th> <th>Style</th> <th>Point Label Style</th> <th>Format</th> <th>Layer</th> <th>Scale Parameter</th> <th>Fixed Scale Fac...</th> <th>Use drawing sc...</th> </tr> </thead> <tbody> <tr> <td>Ahp</td> <td><input checked="" type="checkbox"/> Standard</td> <td><input checked="" type="checkbox"/> Nummer m. k</td> <td>\$*</td> <td><input checked="" type="checkbox"/> Ahp</td> <td><input checked="" type="checkbox"/> Parameter 1</td> <td><input type="checkbox"/> 1.000</td> <td><input type="checkbox"/> No</td> </tr> <tr> <td>New</td> <td><input type="checkbox"/> &lt;default&gt;</td> <td><input checked="" type="checkbox"/> &lt;default&gt;</td> <td>\$*</td> <td><input type="checkbox"/></td> <td><input checked="" type="checkbox"/> Parameter 1</td> <td><input type="checkbox"/> 1.000</td> <td><input type="checkbox"/> No</td> </tr> </tbody> </table>	Code	Style	Point Label Style	Format	Layer	Scale Parameter	Fixed Scale Fac...	Use drawing sc...	Ahp	<input checked="" type="checkbox"/> Standard	<input checked="" type="checkbox"/> Nummer m. k	\$*	<input checked="" type="checkbox"/> Ahp	<input checked="" type="checkbox"/> Parameter 1	<input type="checkbox"/> 1.000	<input type="checkbox"/> No	New	<input type="checkbox"/> <default>	<input checked="" type="checkbox"/> <default>	\$*	<input type="checkbox"/>	<input checked="" type="checkbox"/> Parameter 1	<input type="checkbox"/> 1.000	<input type="checkbox"/> No	
Code	Style	Point Label Style	Format	Layer	Scale Parameter	Fixed Scale Fac...	Use drawing sc...																				
Ahp	<input checked="" type="checkbox"/> Standard	<input checked="" type="checkbox"/> Nummer m. k	\$*	<input checked="" type="checkbox"/> Ahp	<input checked="" type="checkbox"/> Parameter 1	<input type="checkbox"/> 1.000	<input type="checkbox"/> No																				
New	<input type="checkbox"/> <default>	<input checked="" type="checkbox"/> <default>	\$*	<input type="checkbox"/>	<input checked="" type="checkbox"/> Parameter 1	<input type="checkbox"/> 1.000	<input type="checkbox"/> No																				

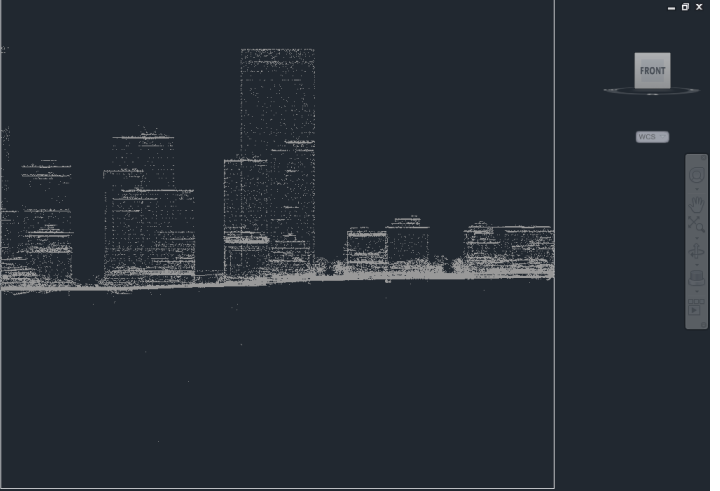
Point Table Styles	Description	Screen grab / DWF / DWG	Default																																																																																																				
<p>Koordinater</p>	<p>Tabel viser nummer, kode, koordinater og kote for udvalgte kotepunkter</p>	 <table border="1"> <thead> <tr> <th colspan="5">KOORDINATTABEL</th> </tr> <tr> <th>NUMMER</th> <th>KODE</th> <th>X</th> <th>Y</th> <th>Z</th> </tr> </thead> <tbody> <tr><td>1</td><td>KOTEPUNKTER</td><td>-221221.853</td><td>341182.318</td><td>30.10</td></tr> <tr><td>2</td><td>KOTEPUNKTER</td><td>-221121.418</td><td>341193.771</td><td>29.58</td></tr> <tr><td>3</td><td>KOTEPUNKTER</td><td>-221121.827</td><td>341185.228</td><td>29.05</td></tr> <tr><td>4</td><td>KOTEPUNKTER</td><td>-221924.799</td><td>341172.441</td><td>28.53</td></tr> <tr><td>5</td><td>KOTEPUNKTER</td><td>-221834.312</td><td>341143.667</td><td>28.12</td></tr> <tr><td>6</td><td>KOTEPUNKTER</td><td>-221751.161</td><td>341997.855</td><td>27.95</td></tr> <tr><td>7</td><td>KOTEPUNKTER</td><td>-221678.532</td><td>341936.701</td><td>27.99</td></tr> <tr><td>8</td><td>KOTEPUNKTER</td><td>-221616.728</td><td>341862.310</td><td>28.12</td></tr> <tr><td>9</td><td>KOTEPUNKTER</td><td>-221556.889</td><td>341782.267</td><td>28.21</td></tr> <tr><td>10</td><td>KOTEPUNKTER</td><td>-221496.381</td><td>341711.937</td><td>27.94</td></tr> <tr><td>11</td><td>KOTEPUNKTER</td><td>-221426.177</td><td>341625.149</td><td>27.64</td></tr> <tr><td>12</td><td>KOTEPUNKTER</td><td>-221341.961</td><td>341562.750</td><td>27.50</td></tr> <tr><td>13</td><td>KOTEPUNKTER</td><td>-221249.191</td><td>341517.117</td><td>27.50</td></tr> <tr><td>14</td><td>KOTEPUNKTER</td><td>-221155.272</td><td>341479.084</td><td>27.45</td></tr> <tr><td>15</td><td>KOTEPUNKTER</td><td>-221154.194</td><td>341452.475</td><td>27.50</td></tr> <tr><td>16</td><td>KOTEPUNKTER</td><td>-219949.664</td><td>341445.946</td><td>27.50</td></tr> <tr><td>17</td><td>KOTEPUNKTER</td><td>-219846.438</td><td>341459.287</td><td>27.50</td></tr> <tr><td>18</td><td>KOTEPUNKTER</td><td>-219748.378</td><td>341481.498</td><td>27.50</td></tr> </tbody> </table>	KOORDINATTABEL					NUMMER	KODE	X	Y	Z	1	KOTEPUNKTER	-221221.853	341182.318	30.10	2	KOTEPUNKTER	-221121.418	341193.771	29.58	3	KOTEPUNKTER	-221121.827	341185.228	29.05	4	KOTEPUNKTER	-221924.799	341172.441	28.53	5	KOTEPUNKTER	-221834.312	341143.667	28.12	6	KOTEPUNKTER	-221751.161	341997.855	27.95	7	KOTEPUNKTER	-221678.532	341936.701	27.99	8	KOTEPUNKTER	-221616.728	341862.310	28.12	9	KOTEPUNKTER	-221556.889	341782.267	28.21	10	KOTEPUNKTER	-221496.381	341711.937	27.94	11	KOTEPUNKTER	-221426.177	341625.149	27.64	12	KOTEPUNKTER	-221341.961	341562.750	27.50	13	KOTEPUNKTER	-221249.191	341517.117	27.50	14	KOTEPUNKTER	-221155.272	341479.084	27.45	15	KOTEPUNKTER	-221154.194	341452.475	27.50	16	KOTEPUNKTER	-219949.664	341445.946	27.50	17	KOTEPUNKTER	-219846.438	341459.287	27.50	18	KOTEPUNKTER	-219748.378	341481.498	27.50	
KOORDINATTABEL																																																																																																							
NUMMER	KODE	X	Y	Z																																																																																																			
1	KOTEPUNKTER	-221221.853	341182.318	30.10																																																																																																			
2	KOTEPUNKTER	-221121.418	341193.771	29.58																																																																																																			
3	KOTEPUNKTER	-221121.827	341185.228	29.05																																																																																																			
4	KOTEPUNKTER	-221924.799	341172.441	28.53																																																																																																			
5	KOTEPUNKTER	-221834.312	341143.667	28.12																																																																																																			
6	KOTEPUNKTER	-221751.161	341997.855	27.95																																																																																																			
7	KOTEPUNKTER	-221678.532	341936.701	27.99																																																																																																			
8	KOTEPUNKTER	-221616.728	341862.310	28.12																																																																																																			
9	KOTEPUNKTER	-221556.889	341782.267	28.21																																																																																																			
10	KOTEPUNKTER	-221496.381	341711.937	27.94																																																																																																			
11	KOTEPUNKTER	-221426.177	341625.149	27.64																																																																																																			
12	KOTEPUNKTER	-221341.961	341562.750	27.50																																																																																																			
13	KOTEPUNKTER	-221249.191	341517.117	27.50																																																																																																			
14	KOTEPUNKTER	-221155.272	341479.084	27.45																																																																																																			
15	KOTEPUNKTER	-221154.194	341452.475	27.50																																																																																																			
16	KOTEPUNKTER	-219949.664	341445.946	27.50																																																																																																			
17	KOTEPUNKTER	-219846.438	341459.287	27.50																																																																																																			
18	KOTEPUNKTER	-219748.378	341481.498	27.50																																																																																																			

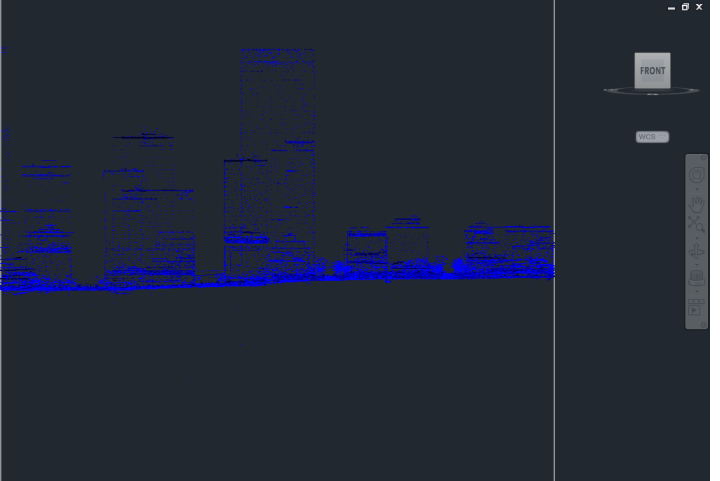
7.3 Point Clouds

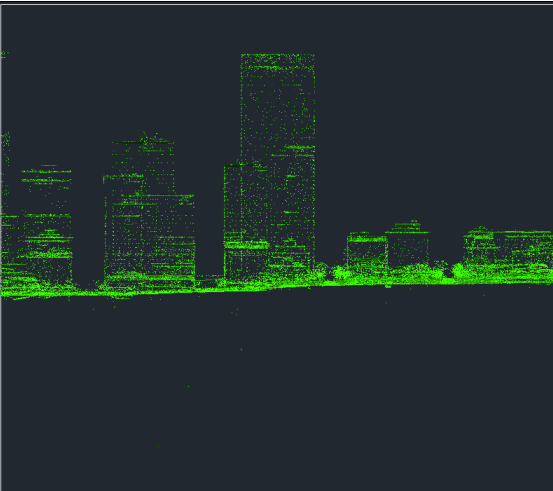
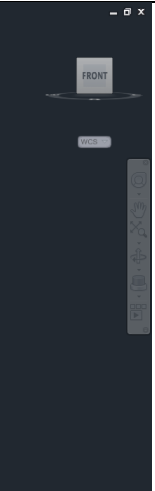
Point Cloud Styles	Description	Screen grab / DWF / DWG		Default
Basis (samme farve)	Viser punkter fra punkt sky i samme farve BYLAYER (V-SITE-SCAN) <div style="border: 1px solid black; padding: 5px; margin-top: 10px;">                         Single Color                          Rainbow                          0.000                          1.000  <span style="display: inline-block; width: 15px; height: 15px; background-color: gray; border: 1px solid black;"></span> 253                     </div>			Ja
Blå (skala)	Viser punkter fra punkt sky i blå farve skala (V-SITE-SCAN) <div style="border: 1px solid black; padding: 5px; margin-top: 10px;">                         Scaled Color Intensity                          Blues                     </div>			

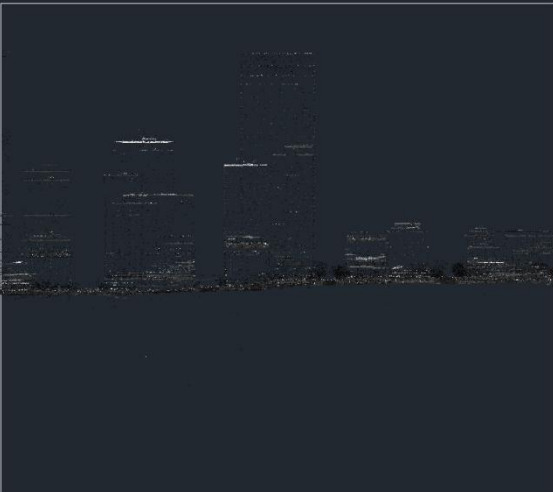
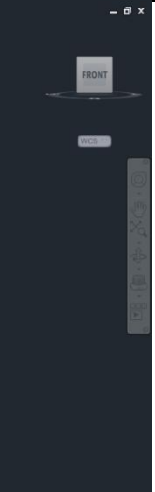
<p>Grøn (skala)</p>	<p>Viser punkter fra punkt sky i grøn farve skala (V-SITE-SCAN)</p> <p>Scaled Color Intensity Greens</p>				
<p>Grå (skala)</p>	<p>Viser punkter fra punkt sky i grå farve skala (V-SITE-SCAN)</p> <p>Grayscale Intensity Rainbow</p>				



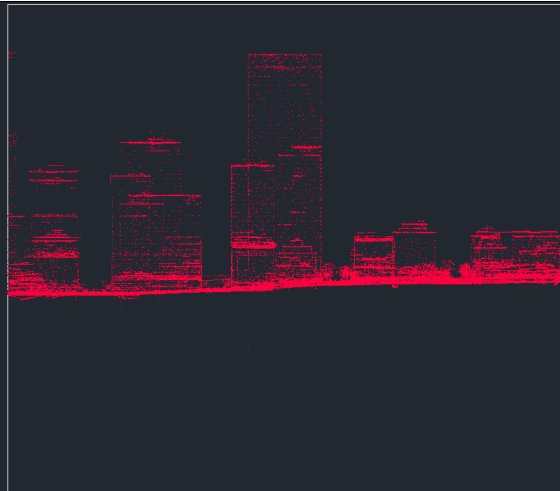
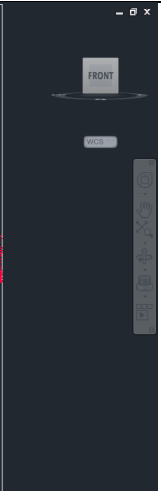
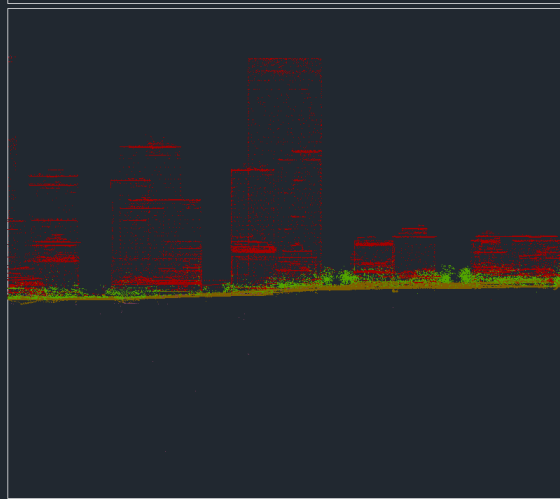
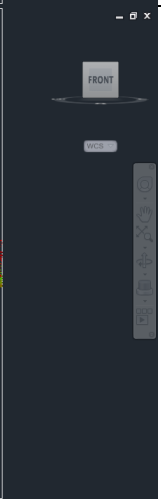

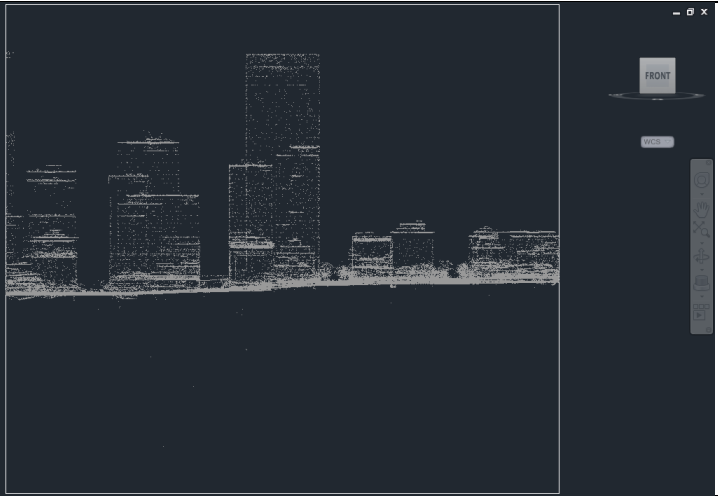
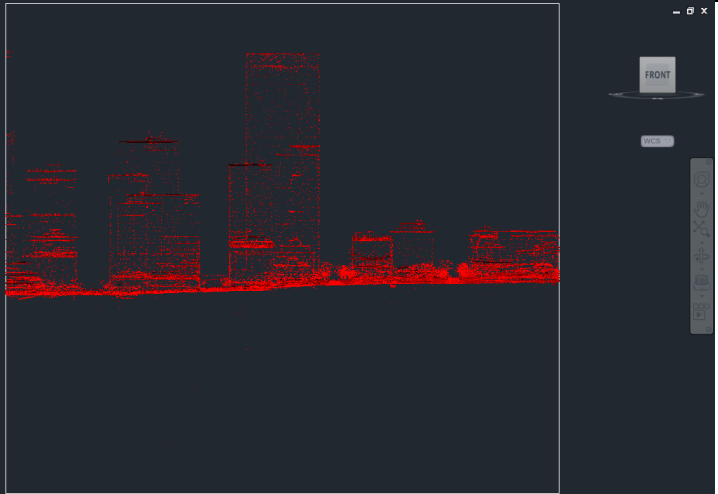
<p>Kote (interval)</p>	<p>Viser punkter fra punkt sky med farve skala Rainbow ud fra punkters koter (V-SITE-SCAN)</p> <div data-bbox="451 324 735 406" style="border: 1px solid black; padding: 5px;"> <p>Elevation Ranges Rainbow</p> </div>																																																																									
<p>LIDAR (klasser)</p>	<p>Viser punkter fra punkt sky med LIDAR klasser, hvor farvevalg kan ses i vindue nedenfor (V-SITE-SCAN)</p> <div data-bbox="451 812 735 893" style="border: 1px solid black; padding: 5px;"> <p>Classification Rainbow</p> </div> <table border="1" data-bbox="451 925 945 1169"> <tr> <td><input checked="" type="checkbox"/></td> <td>0 Created, never classified</td> <td>253</td> <td><input checked="" type="checkbox"/></td> <td>V-SITE-SCAN</td> </tr> <tr> <td><input checked="" type="checkbox"/></td> <td>1 Unclassified</td> <td>253</td> <td><input checked="" type="checkbox"/></td> <td>V-SITE-SCAN</td> </tr> <tr> <td><input checked="" type="checkbox"/></td> <td>2 Ground</td> <td>44</td> <td><input checked="" type="checkbox"/></td> <td>V-SITE-SCAN</td> </tr> <tr> <td><input checked="" type="checkbox"/></td> <td>3 Low Vegetation</td> <td>62</td> <td><input checked="" type="checkbox"/></td> <td>V-SITE-SCAN</td> </tr> <tr> <td><input checked="" type="checkbox"/></td> <td>4 Medium Vegetation</td> <td>72</td> <td><input checked="" type="checkbox"/></td> <td>V-SITE-SCAN</td> </tr> <tr> <td><input checked="" type="checkbox"/></td> <td>5 High Vegetation</td> <td>82</td> <td><input checked="" type="checkbox"/></td> <td>V-SITE-SCAN</td> </tr> <tr> <td><input checked="" type="checkbox"/></td> <td>6 Building</td> <td>12</td> <td><input checked="" type="checkbox"/></td> <td>V-SITE-SCAN</td> </tr> <tr> <td><input checked="" type="checkbox"/></td> <td>7 Low point(noise)</td> <td>235</td> <td><input checked="" type="checkbox"/></td> <td>V-SITE-SCAN</td> </tr> <tr> <td><input checked="" type="checkbox"/></td> <td>8 Model key-point(mass point)</td> <td>249</td> <td><input checked="" type="checkbox"/></td> <td>V-SITE-SCAN</td> </tr> <tr> <td><input checked="" type="checkbox"/></td> <td>9 Water</td> <td>140</td> <td><input checked="" type="checkbox"/></td> <td>V-SITE-SCAN</td> </tr> <tr> <td><input checked="" type="checkbox"/></td> <td>10 Reserved</td> <td>253</td> <td><input checked="" type="checkbox"/></td> <td>V-SITE-SCAN</td> </tr> <tr> <td><input checked="" type="checkbox"/></td> <td>11 Reserved</td> <td>253</td> <td><input checked="" type="checkbox"/></td> <td>V-SITE-SCAN</td> </tr> <tr> <td><input checked="" type="checkbox"/></td> <td>12 Overlap Points</td> <td>251</td> <td><input checked="" type="checkbox"/></td> <td>V-SITE-SCAN</td> </tr> <tr> <td><input checked="" type="checkbox"/></td> <td>13 Reserved</td> <td>253</td> <td><input checked="" type="checkbox"/></td> <td>V-SITE-SCAN</td> </tr> </table>	<input checked="" type="checkbox"/>	0 Created, never classified	253	<input checked="" type="checkbox"/>	V-SITE-SCAN	<input checked="" type="checkbox"/>	1 Unclassified	253	<input checked="" type="checkbox"/>	V-SITE-SCAN	<input checked="" type="checkbox"/>	2 Ground	44	<input checked="" type="checkbox"/>	V-SITE-SCAN	<input checked="" type="checkbox"/>	3 Low Vegetation	62	<input checked="" type="checkbox"/>	V-SITE-SCAN	<input checked="" type="checkbox"/>	4 Medium Vegetation	72	<input checked="" type="checkbox"/>	V-SITE-SCAN	<input checked="" type="checkbox"/>	5 High Vegetation	82	<input checked="" type="checkbox"/>	V-SITE-SCAN	<input checked="" type="checkbox"/>	6 Building	12	<input checked="" type="checkbox"/>	V-SITE-SCAN	<input checked="" type="checkbox"/>	7 Low point(noise)	235	<input checked="" type="checkbox"/>	V-SITE-SCAN	<input checked="" type="checkbox"/>	8 Model key-point(mass point)	249	<input checked="" type="checkbox"/>	V-SITE-SCAN	<input checked="" type="checkbox"/>	9 Water	140	<input checked="" type="checkbox"/>	V-SITE-SCAN	<input checked="" type="checkbox"/>	10 Reserved	253	<input checked="" type="checkbox"/>	V-SITE-SCAN	<input checked="" type="checkbox"/>	11 Reserved	253	<input checked="" type="checkbox"/>	V-SITE-SCAN	<input checked="" type="checkbox"/>	12 Overlap Points	251	<input checked="" type="checkbox"/>	V-SITE-SCAN	<input checked="" type="checkbox"/>	13 Reserved	253	<input checked="" type="checkbox"/>	V-SITE-SCAN			
<input checked="" type="checkbox"/>	0 Created, never classified	253	<input checked="" type="checkbox"/>	V-SITE-SCAN																																																																						
<input checked="" type="checkbox"/>	1 Unclassified	253	<input checked="" type="checkbox"/>	V-SITE-SCAN																																																																						
<input checked="" type="checkbox"/>	2 Ground	44	<input checked="" type="checkbox"/>	V-SITE-SCAN																																																																						
<input checked="" type="checkbox"/>	3 Low Vegetation	62	<input checked="" type="checkbox"/>	V-SITE-SCAN																																																																						
<input checked="" type="checkbox"/>	4 Medium Vegetation	72	<input checked="" type="checkbox"/>	V-SITE-SCAN																																																																						
<input checked="" type="checkbox"/>	5 High Vegetation	82	<input checked="" type="checkbox"/>	V-SITE-SCAN																																																																						
<input checked="" type="checkbox"/>	6 Building	12	<input checked="" type="checkbox"/>	V-SITE-SCAN																																																																						
<input checked="" type="checkbox"/>	7 Low point(noise)	235	<input checked="" type="checkbox"/>	V-SITE-SCAN																																																																						
<input checked="" type="checkbox"/>	8 Model key-point(mass point)	249	<input checked="" type="checkbox"/>	V-SITE-SCAN																																																																						
<input checked="" type="checkbox"/>	9 Water	140	<input checked="" type="checkbox"/>	V-SITE-SCAN																																																																						
<input checked="" type="checkbox"/>	10 Reserved	253	<input checked="" type="checkbox"/>	V-SITE-SCAN																																																																						
<input checked="" type="checkbox"/>	11 Reserved	253	<input checked="" type="checkbox"/>	V-SITE-SCAN																																																																						
<input checked="" type="checkbox"/>	12 Overlap Points	251	<input checked="" type="checkbox"/>	V-SITE-SCAN																																																																						
<input checked="" type="checkbox"/>	13 Reserved	253	<input checked="" type="checkbox"/>	V-SITE-SCAN																																																																						

<p>RGB (True Color)</p>	<p>Viser punkter fra punkt sky med RGB farver (V-SITE-SCAN)</p> <ul style="list-style-type: none"> <li>True Color (RGB)</li> <li>Rainbow</li> </ul>	
<p>Rød (skala)</p>	<p>Viser punkter fra punkt sky i grå farve skala (V-SITE-SCAN)</p> <ul style="list-style-type: none"> <li>Scaled Color Intensity</li> <li>Reds</li> </ul>	

7.4 Surfaces

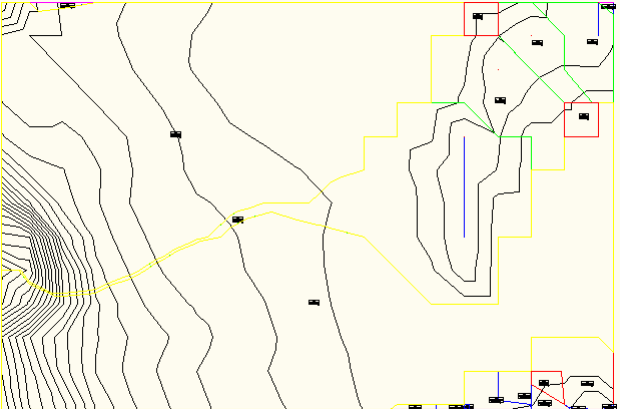
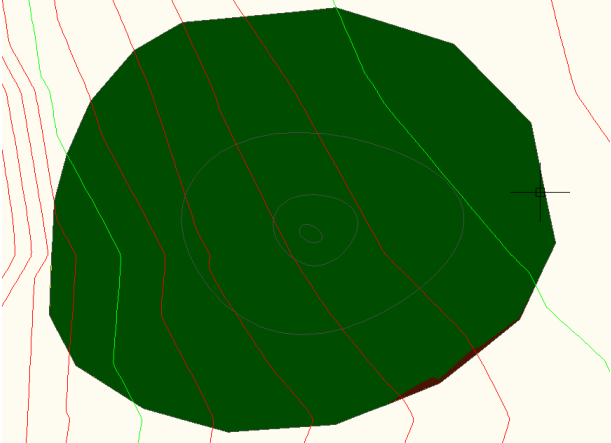
Surface Styles	Description	Screen grab / DWF / DWG	Default
----------------	-------------	-------------------------	---------

<p>Afvandingsområde</p>	<p>Viser surface vandskel</p> <p>Områder beksrives med tekst (label)</p>		
<p>Cut og Fill (TIN Volume)</p>	<p>Viser surface med 2 farver og anvendes til Cut og Fill planer (TIN Volume surface)</p> <p>Farver tilpasses i Surface Properties &gt; Definition, hvor oprettes to kote intervaller med kote 0 som skæringsniveau</p> <p>Kote i sådanne TIN Volume surfaces er relative koter.</p>		

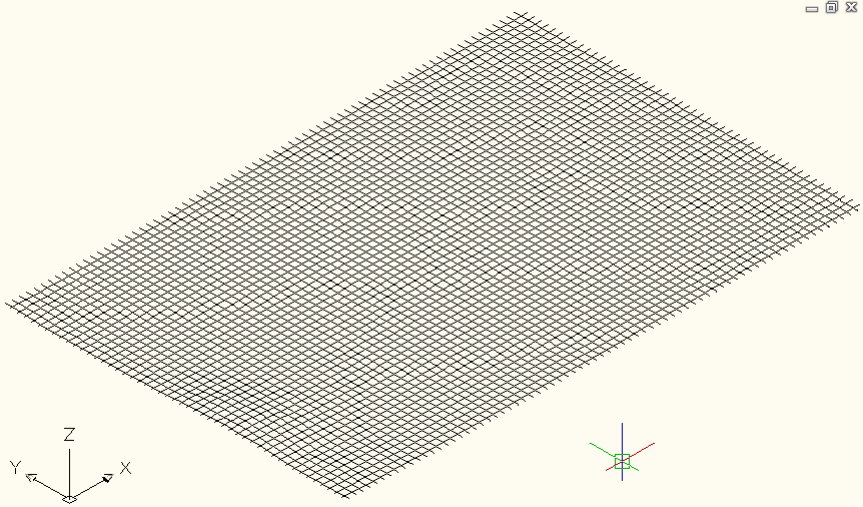
<p>Farver (1 m)</p>	<p>Viser surface med 4 farver</p>	
<p>Grid (25 m)</p>	<p>Viser surface med grid på 25 m i X og Y retning</p>	

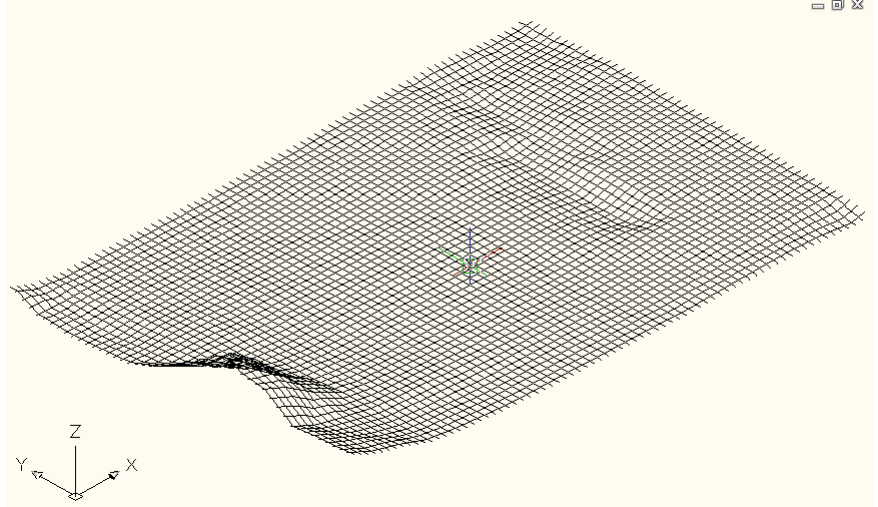
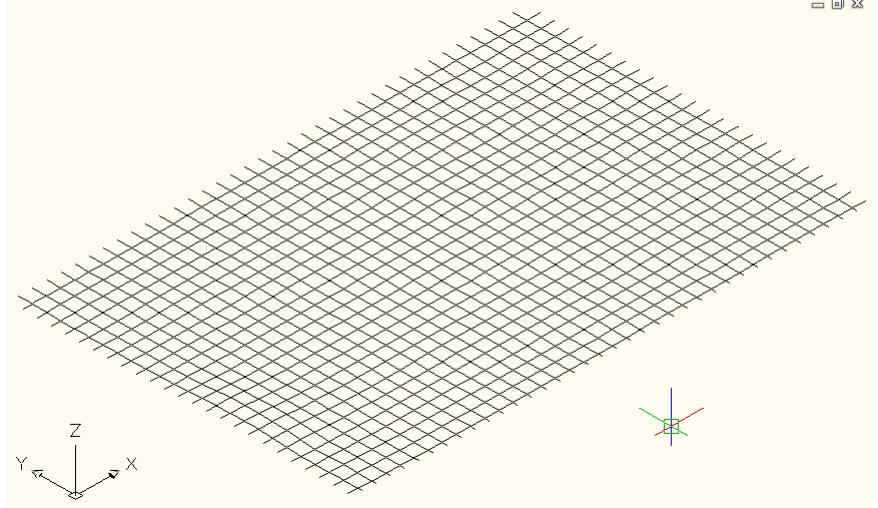
<p>Grid (25 m) som overdrivelse</p>	<p>Viser surface med grid på 25 m i X og Y retning, men med 10 x overdrivelse i Z (kote)</p>		
<p>Grid (50 m)</p>	<p>Viser surface med grid på 50 m i X og Y retning</p>		

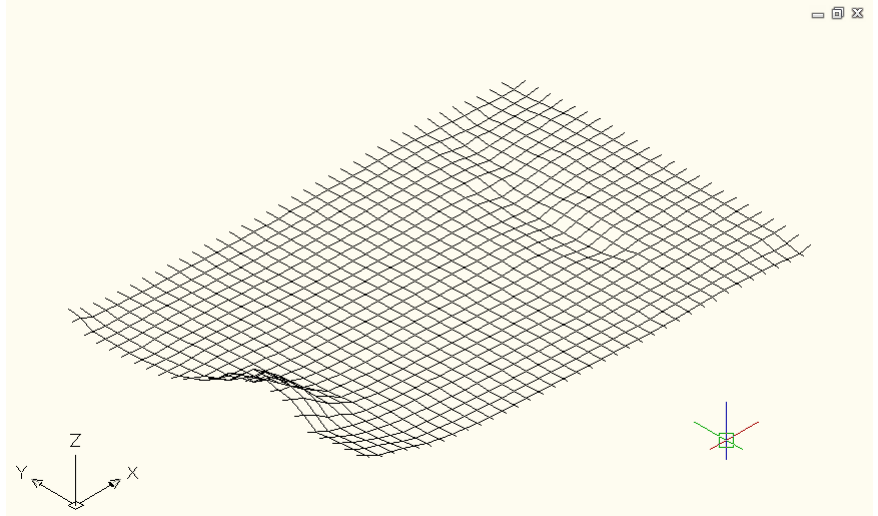
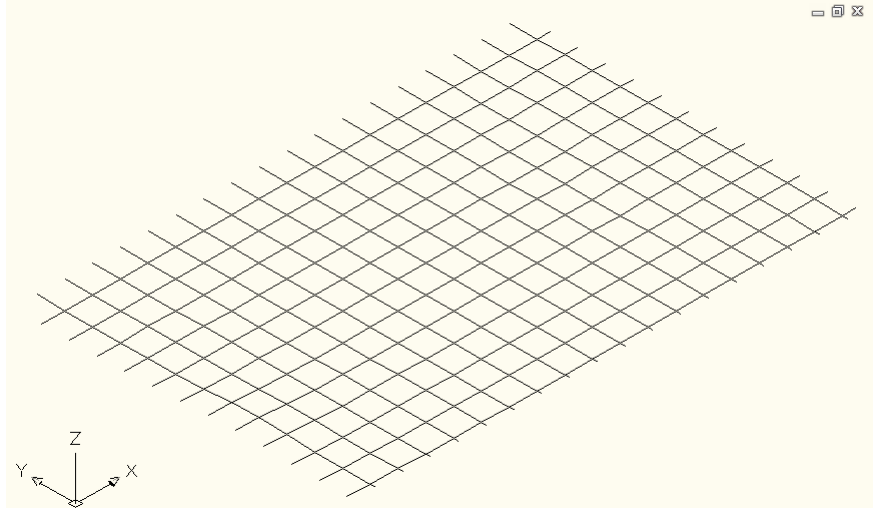
<p>Grid (50 m) som overdrivelse</p>	<p>Viser surface med grid på 50 m i X og Y retning, men med 10 x overdrivelse i Z (kote)</p>	 <p>A 3D perspective view of a surface plot. The surface is represented by a grid of lines. The grid is denser in the X and Y directions and more widely spaced in the Z direction, indicating a 10x vertical exaggeration. A 3D coordinate system is shown in the bottom left corner with axes labeled X, Y, and Z. A small green square is visible on the surface. In the top right corner, there are icons for zooming and panning.</p>	
<p>Grid (100 m)</p>	<p>Viser surface med grid på 100 m i X og Y retning</p>	 <p>A 3D perspective view of a surface plot. The surface is represented by a grid of lines. The grid is significantly coarser than the one above, with a spacing of 100m in the X and Y directions. A 3D coordinate system is shown in the bottom left corner with axes labeled X, Y, and Z. In the top right corner, there are icons for zooming and panning.</p>	

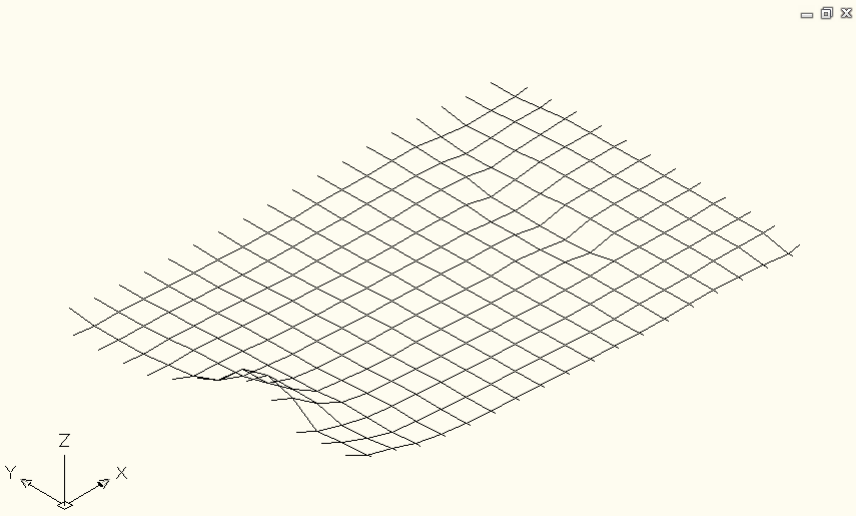
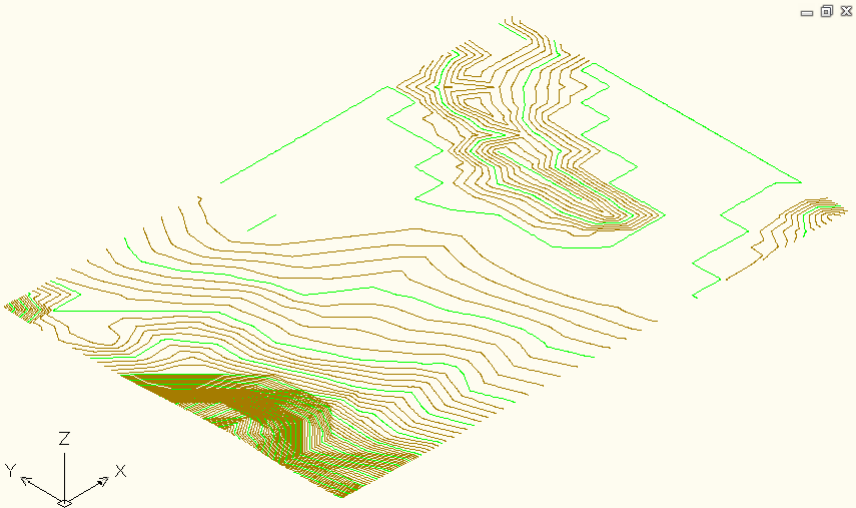
<p>Grid (100 m) som overdrivelse</p>	<p>Viser surface med grid på 100 m i X og Y retning, men med 10 x overdrivelse i Z (kote)</p>	 <p>A 3D wireframe grid representing a surface. The grid is composed of lines in the X and Y directions, with a vertical Z-axis. The surface is shown with a 10x vertical exaggeration. A 3D coordinate system with X, Y, and Z axes is visible in the bottom left corner. In the top right corner, there are small icons for zooming and panning.</p>	
<p>Kurver (0.25 m)</p>	<p>Viser surface som højdekurver med 25 cm og farver rød/grøn</p>	 <p>A 3D surface representation using contour lines. The lines are colored in shades of red and green, indicating different elevations. The surface is shown with a 10x vertical exaggeration. A 3D coordinate system with X, Y, and Z axes is visible in the bottom left corner. In the top right corner, there are small icons for zooming and panning.</p>	

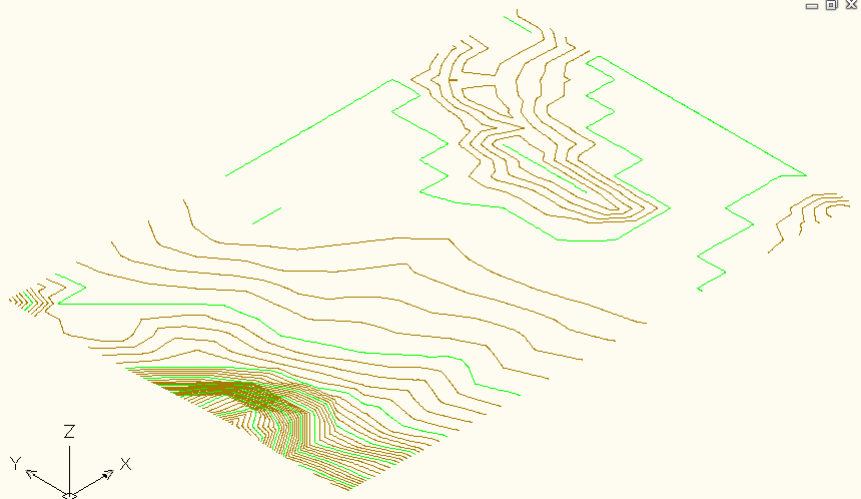
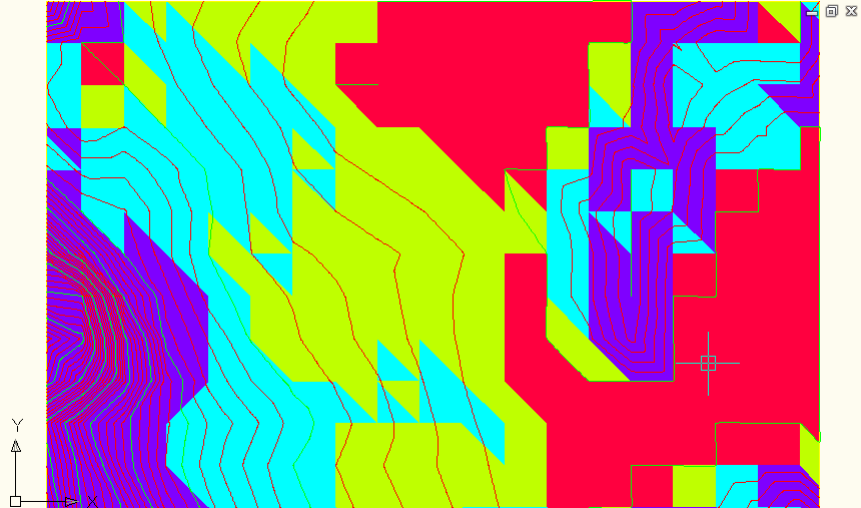
<p>Kurver (½ m)</p>	<p>Viser surface som højdekurver med ½ m og farver rød/grøn</p>		
<p>Kurver (½ m) med hældninger</p>	<p>Viser surface med forskellige farver efter størrelse på hældninger</p>		

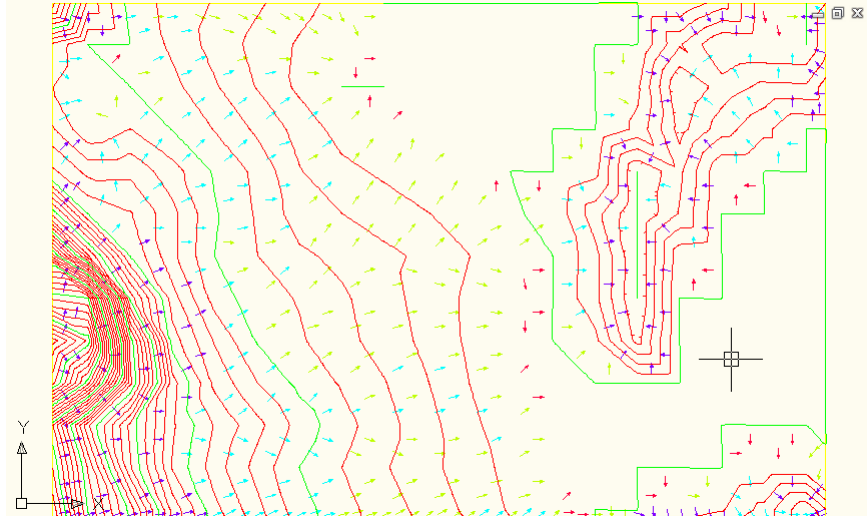
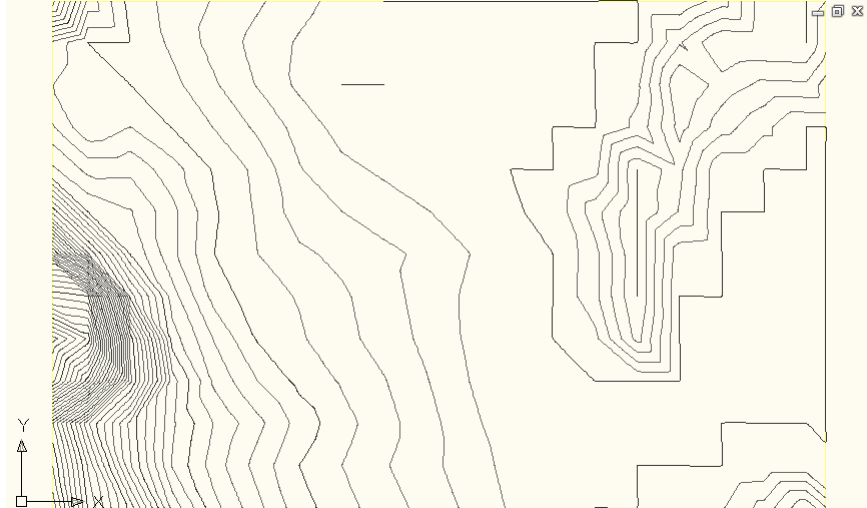

<p>Kurver (½ m) med hældningspile</p>	<p>Viser surface som højdekurver med ½ m og farver rød/grøn plus pile for hældningerne</p>		
<p>Kurver (½ m) som baggrund</p>	<p>Viser surface som højdekurver med ½ m og grå farver</p>		

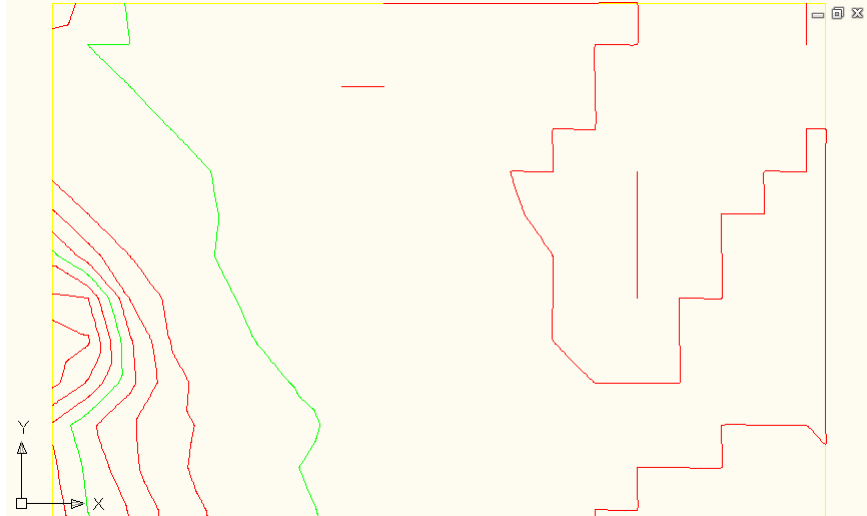
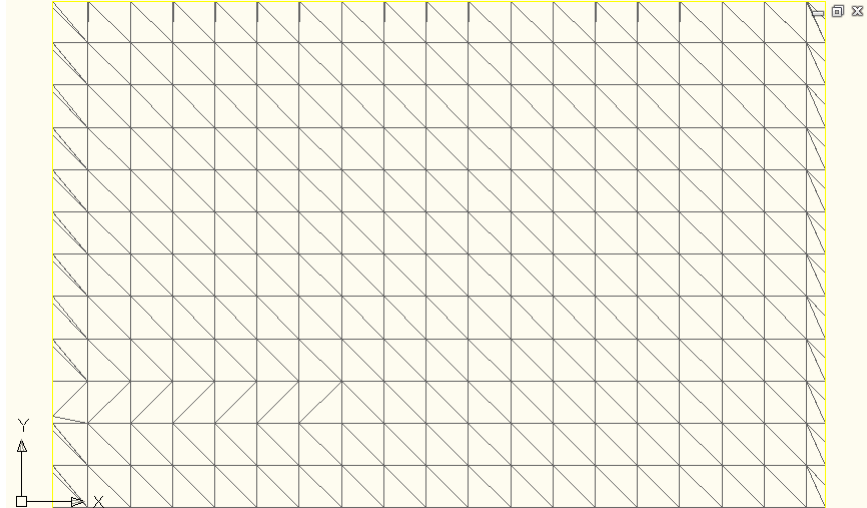
<p>Kurver (2½ m)</p>	<p>Viser surface som højdekurver med 2½ m for farver rød/grøn</p>		
<p>Net og punkter</p>	<p>Viser surface punkter og linier (trekanter)</p>		

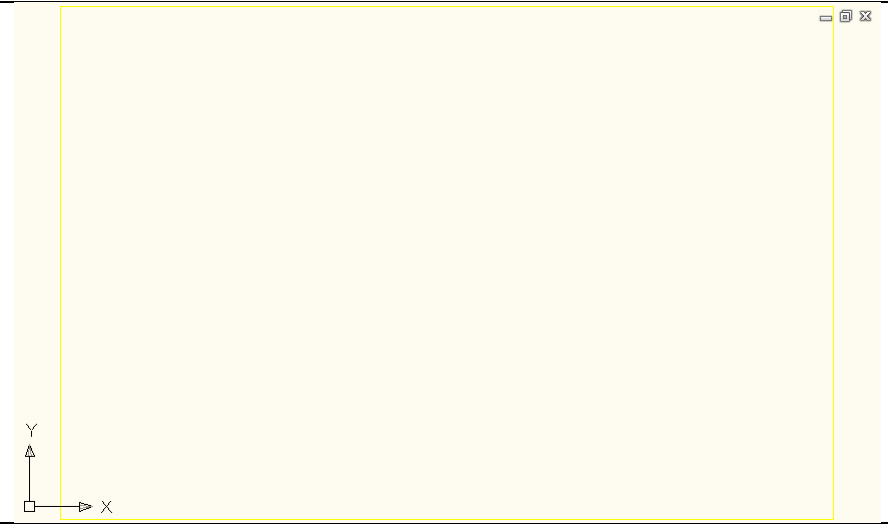
<p>Slukket</p>	<p>Viser surface grænser</p> <p>Gælder både plan og model</p>		
<p>Slukket (uden grænser)</p>	<p>Viser ikke surface</p> <p>Gælder både plan og model</p>		

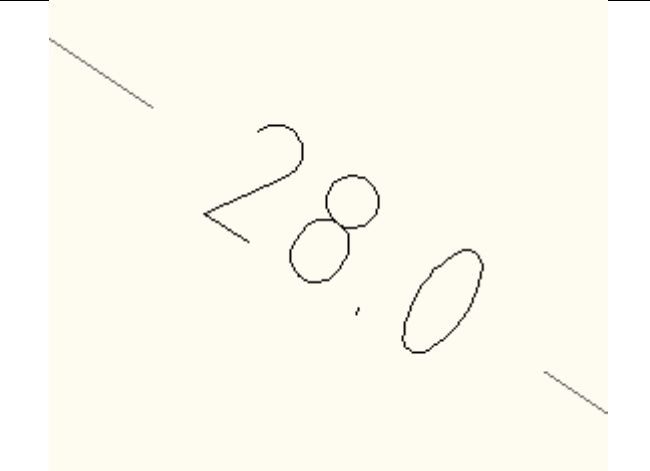
Surface Label Styles Name/Type	Description	Screen grab / DWF / DWG	Default
<p>Contour</p>			
<p>Højdekurver</p>	<p>Viser ækvidistance (højdekurvers koter)</p> <p>Gælder for spot og interval</p>		

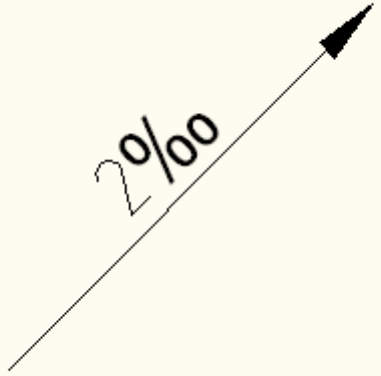
Slope			
Hældning i procent	Viser hældning i procent for et spot		
Hældning i promille	Viser hældning i promille for et spot		
Spot Elevation			

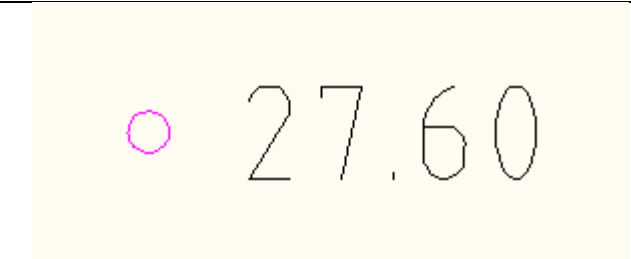
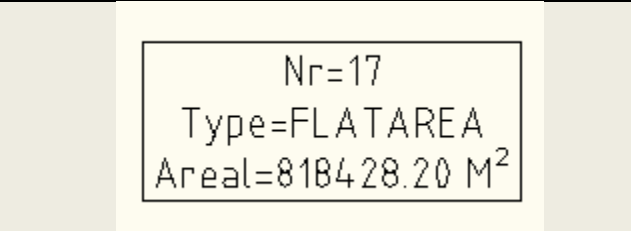
Punkthøjde	Viser kote Gælder både et spot og herfra/hertil		
Watershed			
Afvandingsområde	Viser tekst (label) for type af område Fx om området (defineret af vandskel) er totalt afvandet		

Surface Table Styles Name/Type	Description	Screen grab / DWF / DWG	Default
Direction			
Min og max tegning			
Elevation			
Min og max højde			
Slope			
Min og max hældning			
Slope Arrow			
Hældningspil			
Contour			
Min og max højdekurver			
Watershed			
Afvandingsområde			
User Defined Contour			
Ekstra højdekurver			



**7.5 Parcels**

User-Defined Attributes	Description	Screen grab / DWF / DWG	Default
-------------------------	-------------	-------------------------	---------

<Ingen>			
---------	--	--	--

Parcel Styles	Description	Screen grab / DWF / DWG	Default
Ejendom	Viser parcel med grøn farve		
Område	Viser område med lilla farve		

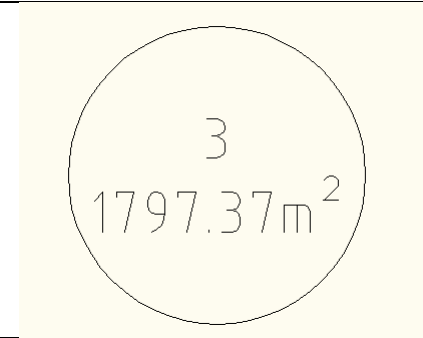
Parcel Label Styles	Description	Screen grab / DWF / DWG	Default
Area			
Betegnelse	Viser nummer på parcel i rund cirkel		

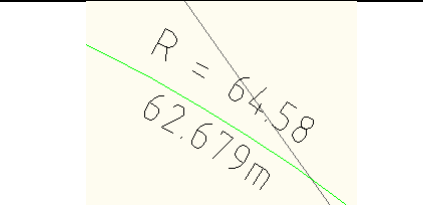
Betegnelsen og areal	Viser nummer og areal på parcel i rund cirkel		
Område	Viser nummer for område/areal i firkant		
Line			
Ejendom	Viser længde og retning for linier		
Curve			
Kurver	Vise længde og radius for kurver		

Parcel Table Styles	Description	Screen grab / DWF / DWG	Default
Line			
<Ingen>			
Curve			
<Ingen>			
Segment			
<Ingen>			
Area			

Ejendom	Viser I tabel nummer på parcel, samt areal og alle længder for linier/kurver, som er med til at definere parcel	<table border="1"> <thead> <tr> <th colspan="4">EJENDOMSDATA</th> </tr> <tr> <th>EJENDOM</th> <th>AREAL (M<sup>2</sup>)</th> <th>OMKREDS (M)</th> <th>SEGMENT LÆNGDE (M)</th> </tr> </thead> <tbody> <tr> <td>1</td> <td>1818.86</td> <td>176.66</td> <td>5.43 27.27 55.63 32.69 17.06 33.14 5.43</td> </tr> <tr> <td>2</td> <td>2403.42</td> <td>218.11</td> <td>67.68 32.31 54.37 65.00 3.76</td> </tr> <tr> <td>3</td> <td>1797.37</td> <td>175.88</td> <td>55.43 32.31 38.57 1.86 15.21 32.31</td> </tr> <tr> <td>4</td> <td>1130.35</td> <td>145.98</td> <td>67.68 0.81 49.79 32.49</td> </tr> </tbody> </table>	EJENDOMSDATA				EJENDOM	AREAL (M <sup>2</sup> )	OMKREDS (M)	SEGMENT LÆNGDE (M)	1	1818.86	176.66	5.43 27.27 55.63 32.69 17.06 33.14 5.43	2	2403.42	218.11	67.68 32.31 54.37 65.00 3.76	3	1797.37	175.88	55.43 32.31 38.57 1.86 15.21 32.31	4	1130.35	145.98	67.68 0.81 49.79 32.49
EJENDOMSDATA																										
EJENDOM	AREAL (M <sup>2</sup> )	OMKREDS (M)	SEGMENT LÆNGDE (M)																							
1	1818.86	176.66	5.43 27.27 55.63 32.69 17.06 33.14 5.43																							
2	2403.42	218.11	67.68 32.31 54.37 65.00 3.76																							
3	1797.37	175.88	55.43 32.31 38.57 1.86 15.21 32.31																							
4	1130.35	145.98	67.68 0.81 49.79 32.49																							

7.6 Grading

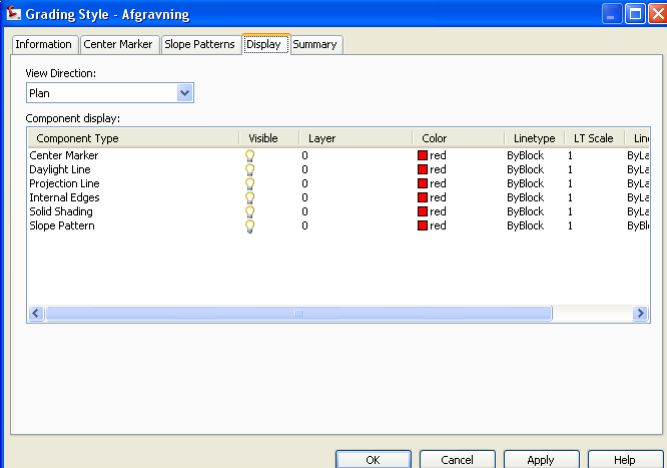
Grading Styles	Description	Screen grab / DWF / DWG	Default
Afgravning	Anvender Slope Pattern Style Skråningssignatur med rød farve for både Plan og Model visning		Ja

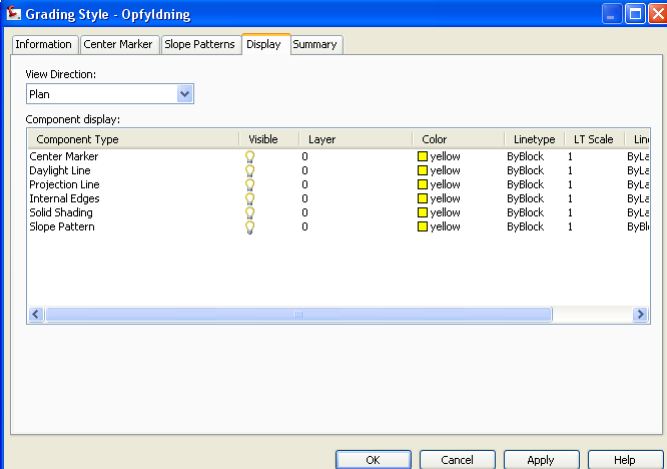

<p>Opfyldning</p>	<p>Anvender Slope Pattern Style Skråningssignatur med gul farve for Plan visning og farve 94 (mørkegrøn) for Model visning</p>		<p>Ja</p>
-------------------	--	---	-----------

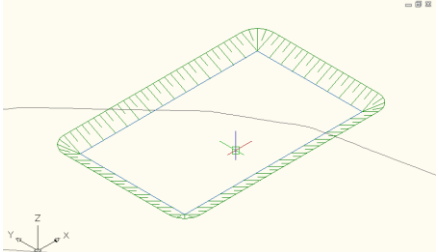
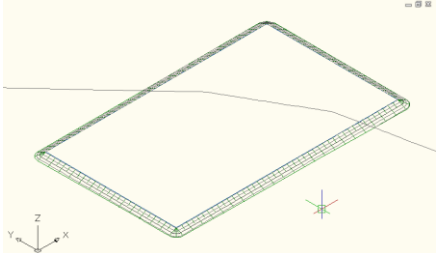
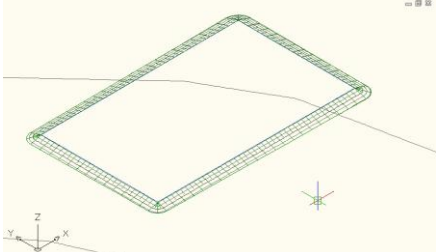
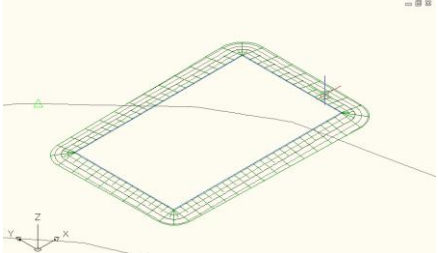

Grading Criteria Sets	Description	Screen grab / DWF / DWG	Default
<p>Basis</p>	<p>Afstand &amp; hældning  Opret skråning med afstand fra feature line med hældning i %</p>		
	<p>Afstand &amp; skråning  Opret skråning med afstand fra feature line med fald fx 1:2</p>		

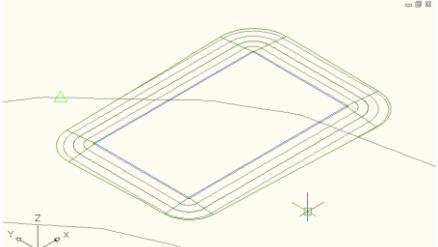
	<p>Højde &amp; hældning</p> <p>Opret skråning med fast højde og fald fx 1:2</p>		
	<p>Terræn &amp; 1-2 hældning</p> <p>Opret skråning mod terræn med fald på 1:2</p>		<p>Ja</p>
	<p>Terræn &amp; 1-3 hældning</p> <p>Opret skråning mod terræn med fald på 1:3</p>		
	<p>Terræn &amp; 1-6 hældning</p> <p>Opret skråning mod terræn med fald på 1:6</p>		

	<p>Terræn og hældning</p> <p>Opret skråning mod terræn med fast fald</p>		
--	--	---	--

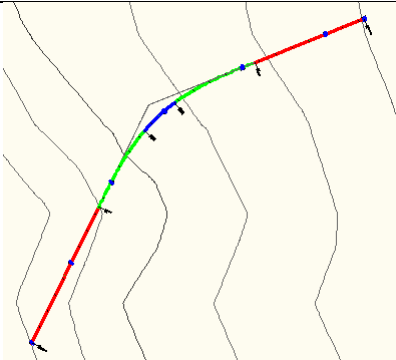
**7.7 Alignments**

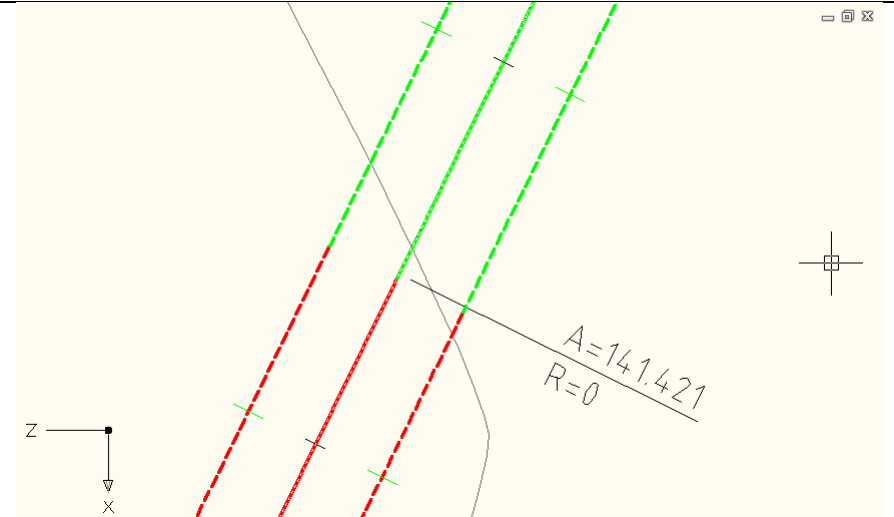
Alignment Style	Description	Screen grab / DWF / DWG	Default
Plot	Linieføring med rød farve uden visning af overgange		
Veje	Linieføring med rød farve for rette linier, grøn farve for overgangskurver og blå farve for kurver		Ja

<p>Veje parallel</p>	<p>Parallele stationeringslinier med rød farve for rette linier, grøn farve for overgangskurver og blå farve for kurver</p> <p>Linetype er HIDDEN for at kunne skelne dem fra den egentlige linieføring.</p>		
----------------------	--	--	---

Alignment Design Checks	Description	Screen grab / DWF / DWG	Default
Design Check Sets			
<Ingen>			
Line			
<Ingen>			
Curve			
<Ingen>			
Spiral			
<Ingen>			
Tangent Intersection			
<Ingen>			

Alignment Label Type/Name	Description	Screen grab / DWF / DWG	Default
Alignment Label Sets			

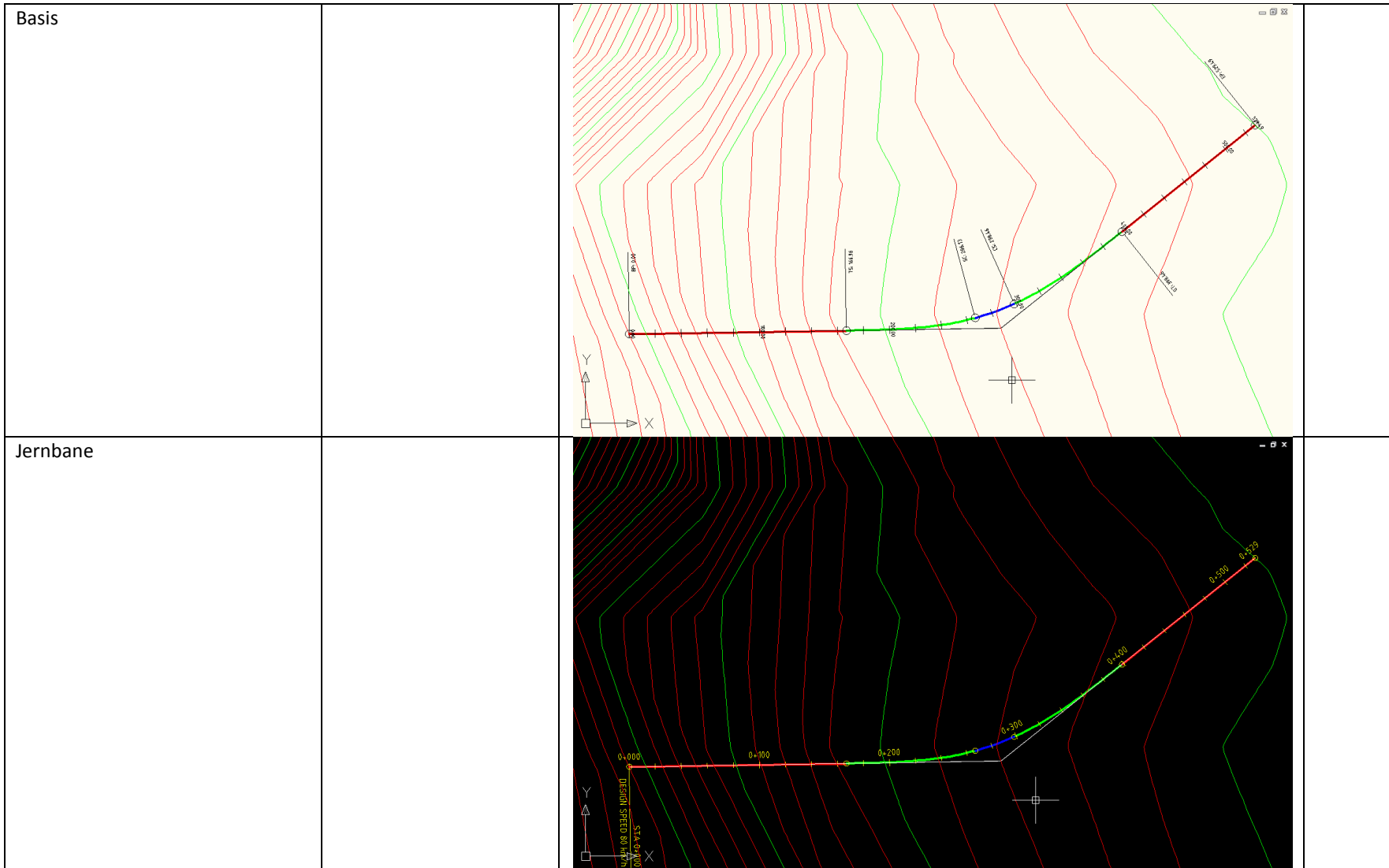

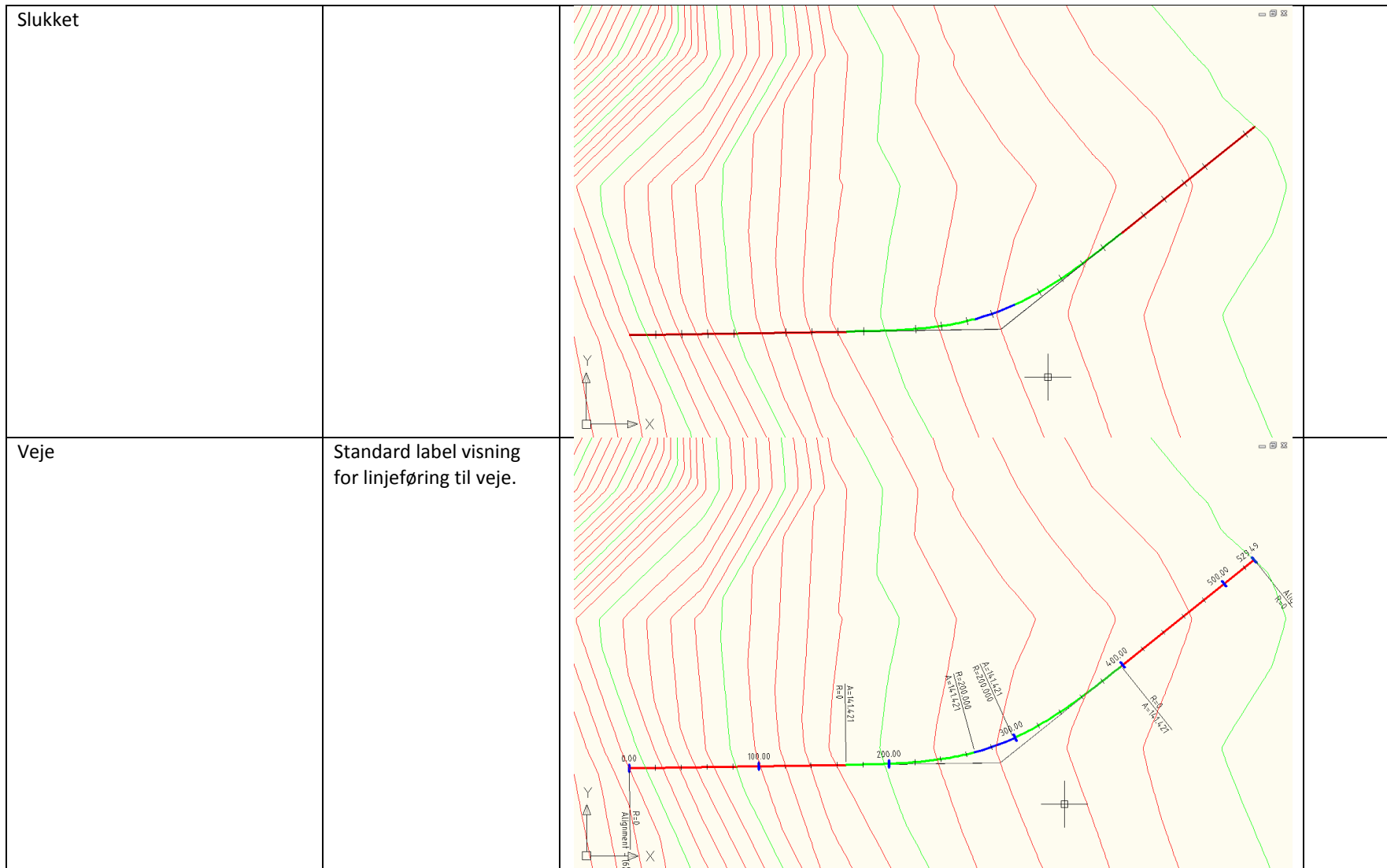

<p>Veje (simpl)</p>			
<p>Veje (superelevation)</p>			
<p>Major Station</p>	<p>Label at Major Stations</p>		
<p>Basis</p>			
<p>Jernbane</p>			
<p>Slukket</p>			

Veje			
Veje (simpel)			
Minor Station	Label at Minor Stations		
Basis			
Jernbane			
Veje			
Veje (simpel)			
Geometry Point	Label at Geometry Points		
Basis			
Jernbane			
Veje			
Veje (simpel)			
Profile Geometry Point	Labels at the profile geometry points on the alignment		
<Ingen>			
Station Equation	Station equation Labels		
Konnektion Jernbane			
Konnektion Veje			
Design Speed	Design Speed labels		
Jernbane			
Veje			
Superelevation Critical Points	Labels at the critical Superelevation points on the alignment		
Skulder superelevation (model)			
Superelevation (model)			
Station Offset	Station Offset Labels		
Sektion og sideafstand			
Line	Tangent labels		
Elementnummer			
Curve	Arc Labels		
Elementnummer			
Spiral	Spiral Labels		
Elementnummer			



Tangent Intersection	PI Labels		
Vinkelspot			

Alignment Table Type/Name	Description	Screen grab / DWF / DWG	Default
Line			
Linietabel			
Curve			
Kurvetabel			
Spiral			
Koltoidetabel			
Segment	Line, curve or spiral element in a single table		
Elementtabel			

**7.8 Profiles**

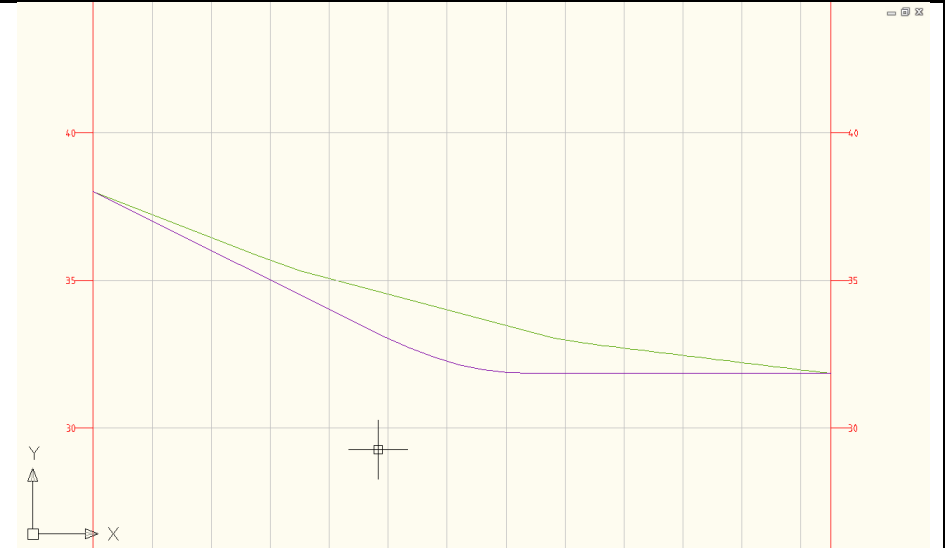
Profile Style	Description	Screen grab / DWF / DWG	Default
Bund (sektion)	Linje med lilla farve (color 202)		

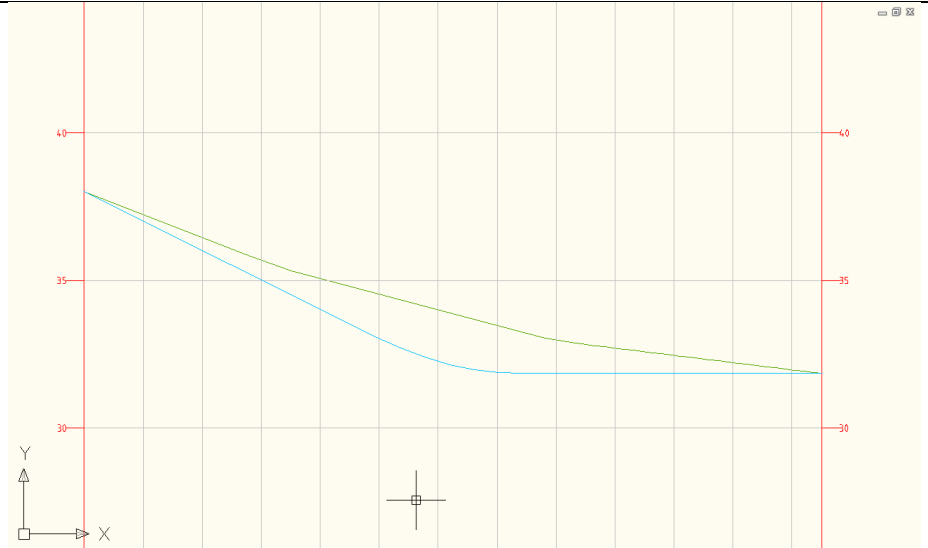
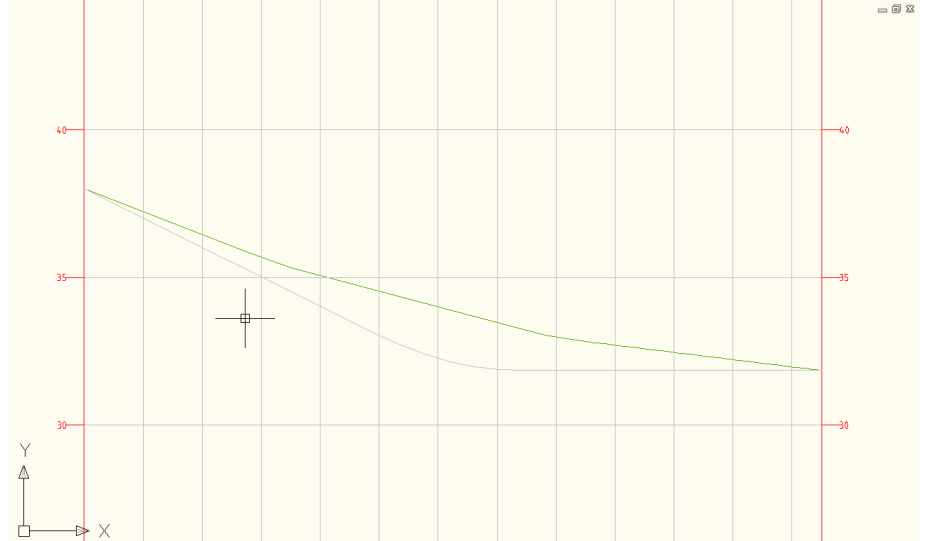
<p>Top (sektion)</p>	<p>Linje med lyseblå farve (color 140)</p>		
<p>Råjord</p>	<p>Linje med grå farve (color 9)</p>		

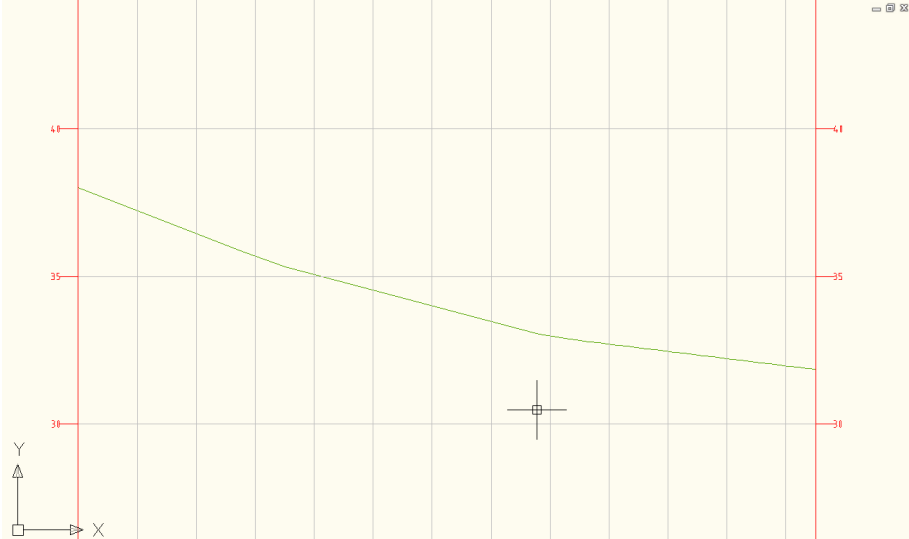
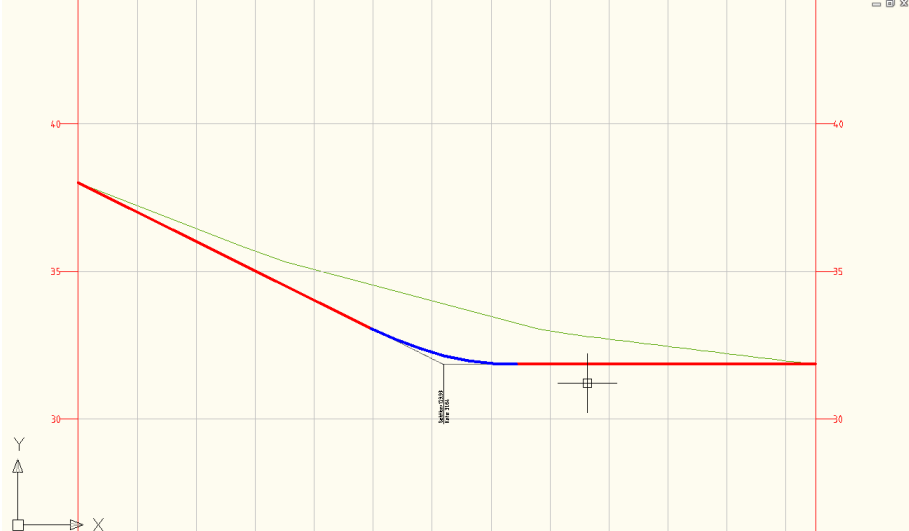
<p>Terræn</p>	<p>Linje med grøn farve (color 72)</p>		
<p>Top (sektion)</p>			
<p>Vejprofil</p>	<p>Linje med rød farve for rette linjer og blå farve for kurver</p> <p>Linetype er Continuous</p>		

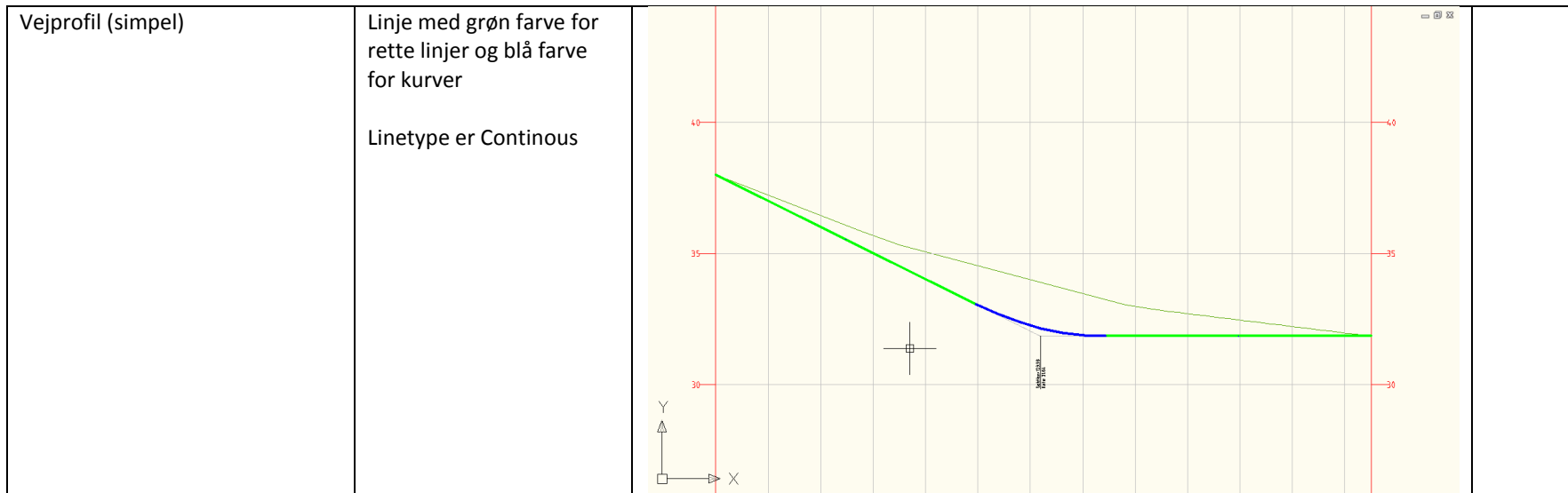

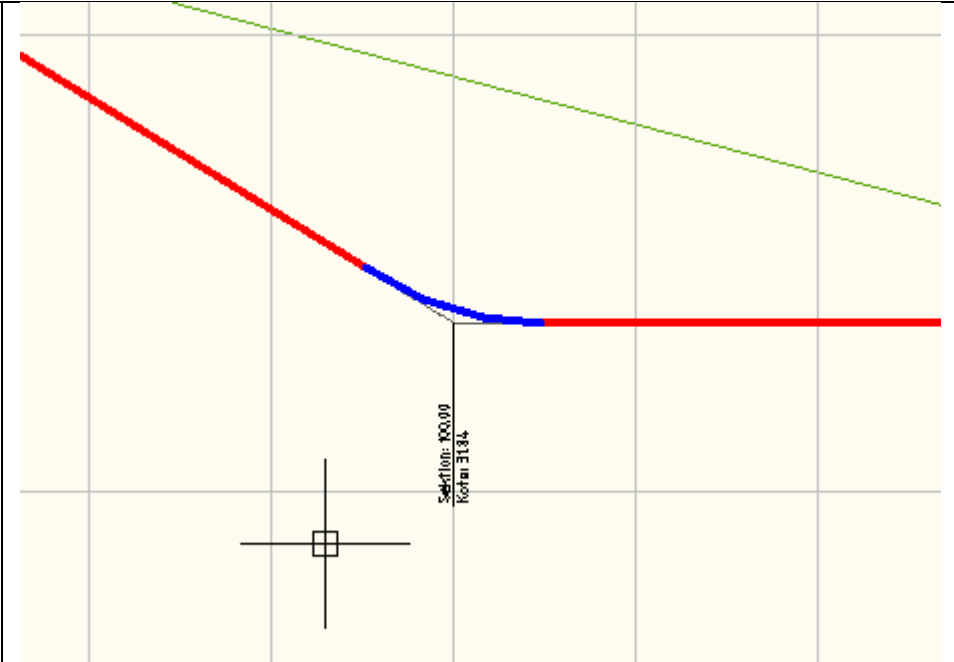

Profile Design Checks	Description	Screen grab / DWF / DWG	Default
Design Check Sets			
<Ingen>			
Line			
<Ingen>			
Curve			
<Ingen>			

Profile Label Type/Name	Description	Screen grab / DWF / DWG	Default
Profile Label Sets			

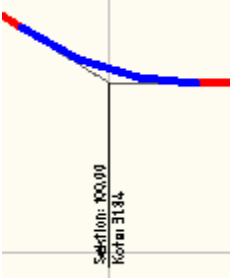
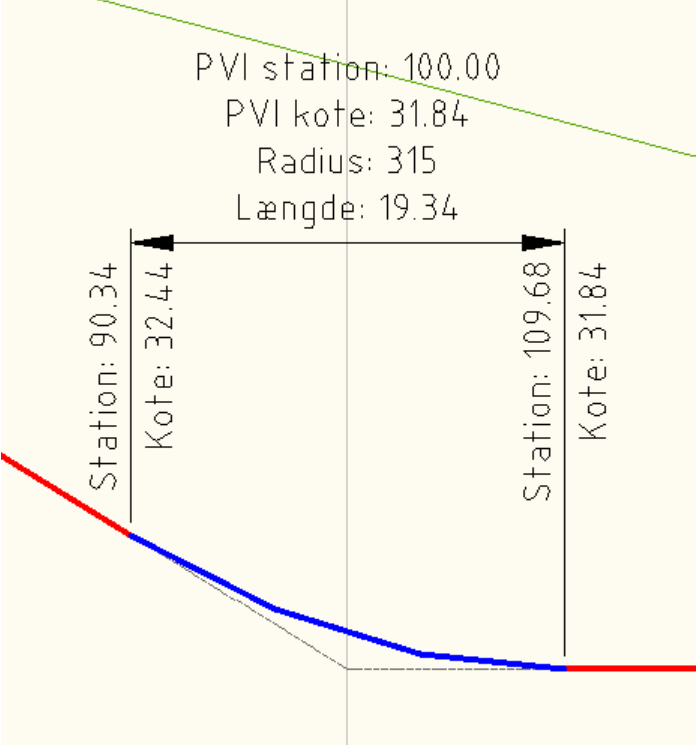
<p>Vejprofil</p>			
Major Station			
Hovedsektion			
Minor Station			
Sektion			
Horizontal Geometry Point			
Sektion og type			
Grade Breaks			
Hældning og højde			
Line	Tangent Labels		
Tangent			
Curve			

<p>Kurver</p> <ul style="list-style-type: none"> <li>• Konkav</li> <li>• Konvex</li> </ul>			
<p>Data</p>	<p>Label bruges for konkave og konvekse kurver</p>		

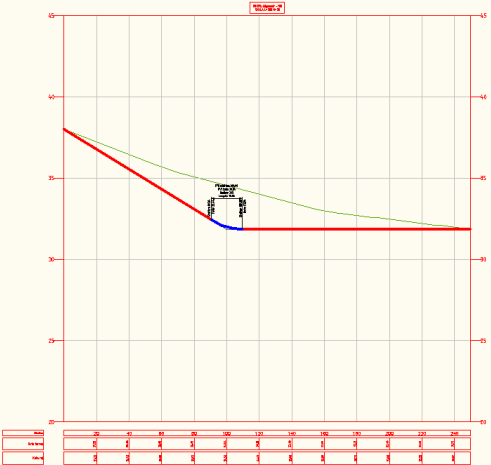
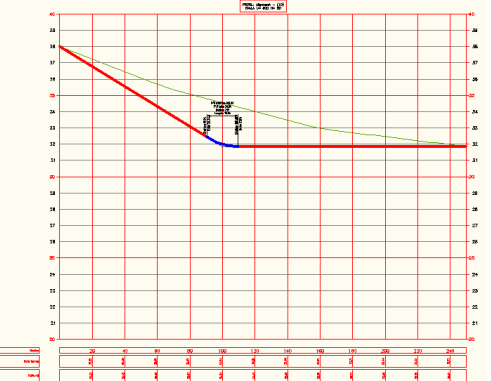
Profile View Type/Name	Description	Screen grab / DWF / DWG	Default
------------------------	-------------	-------------------------	---------

<p>Vejprofil</p>	<p>Standard længdeprofil med en blok ekstra over og under den højeste henholdsvis laveste kote</p> <p>Grid vises med 5m for koter og 20m for stationer</p> <p>Grid for koter overdrives 10x</p>		<p>Ja</p>
<p>Vejprofil (simpel)</p>	<p>Længdeprofil med grid på 1m for koter og 20m for stationer</p> <p>Grid for koter overdrives 10x</p>		
<p>Vejprofil (uden overdrivelse)</p>	<p>Som vejprofil uden overdrivelse</p>		

Profile View Label Type/Name	Description	Screen grab / DWF / DWG	Default
Station Elevation			

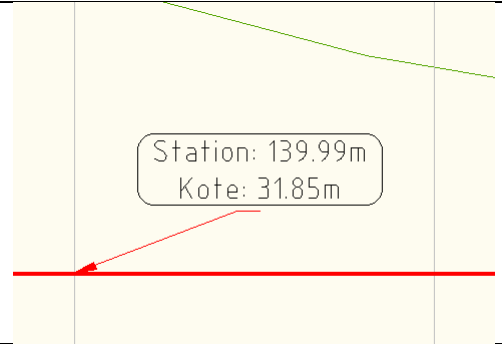
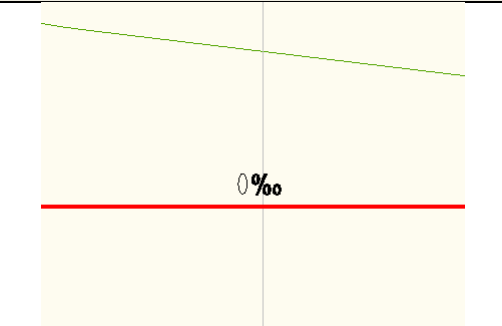
<p>Station og kote</p>			
<p>Depth</p>			
<p>Hældning (promille)</p>			

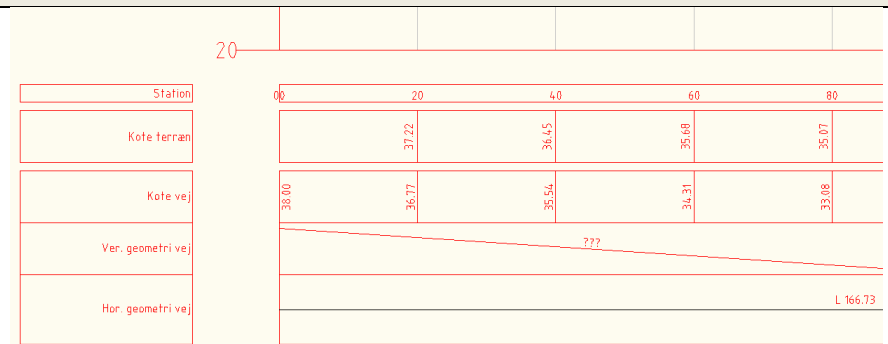
Profile Band Type/Name	Description	Screen grab / DWF / DWG	Default
<p>Profile Band Set</p>			
<p>Vejprofil</p>	<p>Kurvebånd for station, kote terræn pr major station, geometri terræn, kote vej pr major station, vertikal geometri vej og horisontal geometri vej</p>		

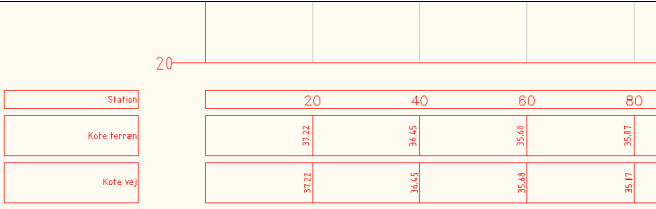

<p>Vejprofil (simpel)</p>	<p>Kurvebånd for major station, kote terræn pr major station og kote vej pr major station</p>		<p>Ja</p>
<p>Vej- og ledningsprofil</p>	<p>Kurvebånd for station, kote terræn pr major station, geometri terræn, kote vej pr major station, vertikal geometri vej og horisontal geometri vej samt tre sæt for komponenter og ledninger</p>	<p>Se under Vej- og ledningsprofil (Spildevand)</p>	
<p>Vej- og ledningsprofil (Fælles)</p>	<p>Kurvebånd for station, kote terræn pr major station, geometri terræn, kote vej pr major station, vertikal geometri vej og horisontal geometri vej samt ét sæt for komponenter og ledninger</p>	<p>Se under Vej- og ledningsprofil (Spildevand)</p>	
<p>Vej- og ledningsprofil (Regnvand)</p>	<p>Kurvebånd for station, kote terræn pr major station, geometri terræn, kote vej pr major station, vertikal geometri vej og horisontal geometri vej samt ét sæt for komponenter og ledninger</p>	<p>Se under Vej- og ledningsprofil (Spildevand)</p>	

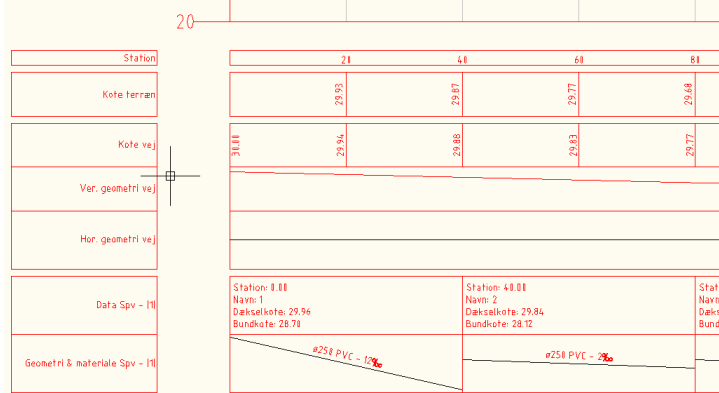
<p>Vej- og ledningsprofil (Spildevand)</p>	<p>Kurvebånd for station, kote terræn pr major station, geometri terræn, kote vej pr major station, vertikal geometri vej og horizontal geometri vej samt ét sæt for komponenter og ledninger</p>		
Profile Data			
Jordart			
Kote terræn			
Kote vej			
Kote vej simpel			
Markslag			
Station			
Station simpel			
Tangeringspunkt			
Vertical Geometry			
Geometri terræn			
Hældning vej i procent			
Profildata			
Ver. Geometri vej			
Horizontal Geometry			
Hor. Geometri vej			
Plandata			
Superelevation Data			
Tværfald			
Sectional Data			
<Ingen>			
Pipe Network			
Fv. Geometri og materiale			
Fv. Komp.data			

Rgv. Geometri og materiale			
Rgv. Komp.data			
Spv. Geometri og materiale			
Spv. Komp.data			

**7.8 Superelevation Views**

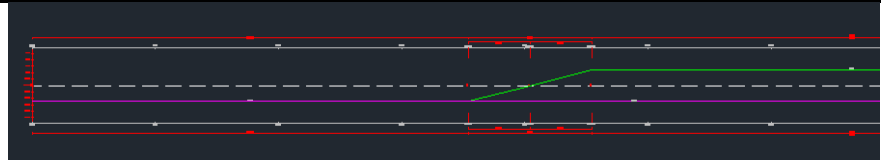
Superelevation View Style	Description	Screen grab / DWF / DWG	Default
Basis	Skema er farve 1 (rød) Linier og tekst er farve 9 (grå)		Ja

Se kapitel 12 for nærmere beskrivelse af Superelevation Views. Der findes pt. ikke andre indstillinger fx tilpasning for udskrivning af hældninger (skema).

**7.9 Sections**

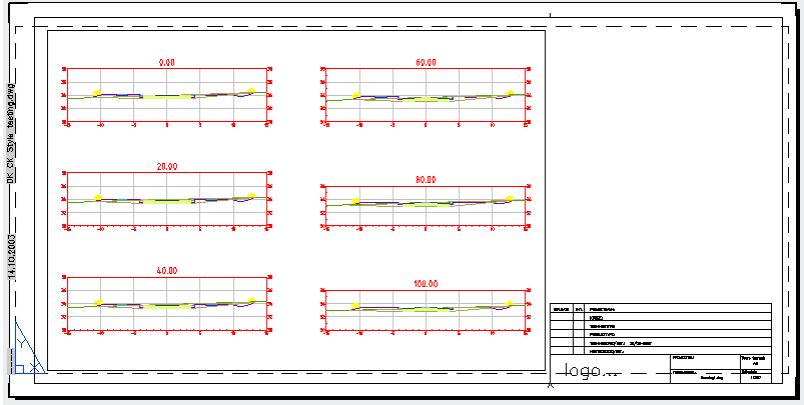
Cross Sections Sheet Templates	Description	Screen grab / DWF / DWG	Default
_AutoCAD Civil 3D A3 Section_DK	Indeholder følgende mål forhold for A3 (liggende):  A3L Tværsnit 1-100 A3L Tværsnit 1-1000 A3L Tværsnit 1-200 A3L Tværsnit 1-2000 A3L Tværsnit 1-500		

Sample Line Styles	Description	Screen grab / DWF / DWG	Default
Sektionsmarkering			

Sample Line Label Styles	Description	Screen grab / DWF / DWG	Default
--------------------------	-------------	-------------------------	---------

Sektionsnavn			
--------------	--	--	--

Section Styles	Description	Screen grab / DWF / DWG	Default
Bund	Linie med farve 202 (mørk lilla)		
Terræn	Linie med farve 72 (mørk grøn)		
Top	Linie med farve 140 (lys blå)		
Vejsektion	Linie med farve 1 (rød)		

Section Label Styles	Description	Screen grab / DWF / DWG	Default
Label Sets			
Slukket			
Major Offset			
<Ingen>			
Minor Offset			
<Ingen>			
Grade Break			
<Ingen>			
Segment			
<Ingen>			

Section View Styles	Description	Screen grab / DWF / DWG	Default
Tværsnit	Standard tværsnit uden kurvebånd  Brønde og ledninger gengives i standard farver efter system		Ja

Group Plot Styles	Description	Screen grab / DWF / DWG	Default
<Ingen>			

Sheet Styles	Description	Screen grab / DWF / DWG	Default
<Ingen>			

Label Styles	Description	Screen grab / DWF / DWG	Default
Offset Elevation			
Offset over kote			
Grade			
Fald (mellem to punkter)			

Section Band Styles	Description	Screen grab / DWF / DWG	Default
Band Sets			
<Ingen>			
Section Data			
<Ingen>			

Section Table Styles	Description	Screen grab / DWF / DWG	Default
Total Volume			
<Ingen>			
Material			
<Ingen>			

**7.10 Pipe Networks**

Parts Lists	Description	Screen grab / DWF / DWG	Default
Dræn	Indeholder materiale og dimension for dræn system og gælder kun for ledninger		
Fælles	Indeholder materiale og dimension for fælles system og gælder komponenter og ledninger		
Regnvand	Indeholder materiale og dimension for regnvand og gælder komponenter og ledninger		
Spildevand	Indeholder materiale og dimension for spildevand og gælder komponenter og ledninger		

Interference Styles	Description	Screen grab / DWF / DWG	Default
<Ingen>			

Pipe Styles	Description	Screen grab / DWF / DWG	Default
Dræn	Ledninger tegnes med grøn farve, linetype ACAD_ISO02W100 og lag C-PIPE-DRN		
Fælles	Ledninger tegnes med rød farve, linetype DASHED og lag C-PIPE-FLS		
Regnvand	Ledninger tegnes med blå farve og lag C-PIPE-RGV		
Spildevand	Ledninger tegnes med rød farve og lag C-PIPE-SPV		

Pipe Rule Set	Description	Screen grab / DWF / DWG	Default
Dræn		<ul style="list-style-type: none"> <li>[-] Cover And Slope                             <ul style="list-style-type: none"> <li>Maximum Cover 7.000m</li> <li>Maximum Slope 50.00%</li> <li>Minimum Cover 1.000m</li> <li>Minimum Slope 0.20%</li> </ul> </li> <li>[-] Length Check                             <ul style="list-style-type: none"> <li>Maximum Length 200.000m</li> <li>Minimum Length 1.000m</li> </ul> </li> </ul>	
Fælles		<ul style="list-style-type: none"> <li>[-] Cover And Slope                             <ul style="list-style-type: none"> <li>Maximum Cover 7.000m</li> <li>Maximum Slope 50.00%</li> <li>Minimum Cover 1.000m</li> <li>Minimum Slope 0.20%</li> </ul> </li> <li>[-] Length Check                             <ul style="list-style-type: none"> <li>Maximum Length 200.000m</li> <li>Minimum Length 1.000m</li> </ul> </li> </ul>	
Regnvand		<ul style="list-style-type: none"> <li>[-] Cover And Slope                             <ul style="list-style-type: none"> <li>Maximum Cover 7.000m</li> <li>Maximum Slope 50.00%</li> <li>Minimum Cover 1.000m</li> <li>Minimum Slope 0.20%</li> </ul> </li> <li>[-] Length Check                             <ul style="list-style-type: none"> <li>Maximum Length 200.000m</li> <li>Minimum Length 1.000m</li> </ul> </li> </ul>	
Spildevand		<ul style="list-style-type: none"> <li>[-] Cover And Slope                             <ul style="list-style-type: none"> <li>Maximum Cover 7.000m</li> <li>Maximum Slope 50.00%</li> <li>Minimum Cover 1.000m</li> <li>Minimum Slope 0.20%</li> </ul> </li> <li>[-] Length Check                             <ul style="list-style-type: none"> <li>Maximum Length 200.000m</li> <li>Minimum Length 1.000m</li> </ul> </li> </ul>	

Pipe Label Styles	Description	Screen grab / DWF / DWG	Default
Plan Profile			
Dræn	Udskriver dimension, materiale og fald i promille med grøn farve langs ledninger		

Fælles	Udskriver dimension, materiale og fald i promille med rød farve langs ledninger		
Regnvand	Udskriver dimension, materiale og fald i promille med blå farve langs ledninger		
Spildevand	Udskriver dimension, materiale og fald i promille med rød farve langs ledninger		
Crossing Section			
<Ingen>			

Pipe Table Styles	Description	Screen grab / DWF / DWG	Default
<Ingen>			

Structure Styles	Description	Screen grab / DWF / DWG	Default
Dræn	Komponenter tegnes med grøn farve		
Fælles	Komponenter tegnes med rød farve		
Regnvand	Komponenter tegnes med blå farve		
Spildevand	Komponenter tegnes med rød farve		

Structure Rule Styles	Description	Screen grab / DWF / DWG	Default
Regnvand		<ul style="list-style-type: none"> <li>Maximum pipe size check                             <ul style="list-style-type: none"> <li>Maximum pipe diameter or width 1.000m</li> </ul> </li> <li>Pipe Drop Across Structure                             <ul style="list-style-type: none"> <li>Drop Reference Location Invert</li> <li>Drop Value 0.000m</li> <li>Maximum Drop Value 0.250m</li> </ul> </li> <li>Set Sump Depth                             <ul style="list-style-type: none"> <li>Sump Depth 0.000m</li> </ul> </li> </ul>	
Spildevand		<ul style="list-style-type: none"> <li>Maximum pipe size check                             <ul style="list-style-type: none"> <li>Maximum pipe diameter or width 1.000m</li> </ul> </li> <li>Pipe Drop Across Structure                             <ul style="list-style-type: none"> <li>Drop Reference Location Invert</li> <li>Drop Value 0.100m</li> <li>Maximum Drop Value 0.500m</li> </ul> </li> <li>Set Sump Depth                             <ul style="list-style-type: none"> <li>Sump Depth 0.000m</li> </ul> </li> </ul>	

Structure Label Styles	Description	Screen grab / DWF / DWG	Default
Dræn	Udskriver nummer med grøn farve til højre for komponent		
Child of Dræn	Udskriver nummer, dæksel kote og bund kote med grøn farve til højre for komponent		

	Label kan plotredigeres		
Fælles	Udskriver nummer med rød farve til højre for komponent		
Child of Fælles	Udskriver nummer, dæksel kote og bund kote med rød farve til højre for komponent  Label kan plotredigeres		
Regnvand	Udskriver nummer med blå farve til højre for komponent		
Child of Regnvand	Udskriver nummer, dæksel kote og bund kote med blå farve til højre for komponent  Label kan plotredigeres		
Spildevand	Udskriver nummer med rød farve til højre for komponent		
Child of Spildevand	Udskriver nummer, dæksel kote og bund kote med rød farve til højre for komponent  Label kan plotredigeres		

Structure Table Styles	Description	Screen grab / DWF / DWG	Default
<Ingen>			

**7.11 Corridors**

Corridor Styles	Description	Screen grab / DWF / DWG	Default
<Ingen>			

Assembly Styles	Description	Screen grab / DWF / DWG	Default
Basis			Ja

Mass Haul Line Styles	Description	Screen grab / DWF / DWG	Default
<Ingen>			

Mass Haul View Styles	Description	Screen grab / DWF / DWG	Default
-----------------------	-------------	-------------------------	---------

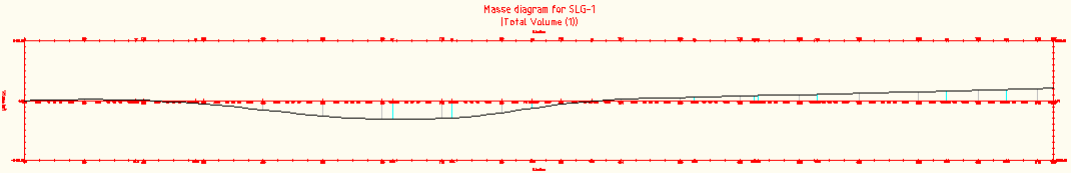

Masse	Standard "profil" til masse diagram		Ja
-------	-------------------------------------	--	----

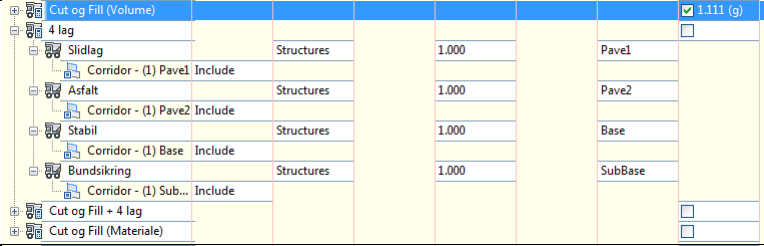
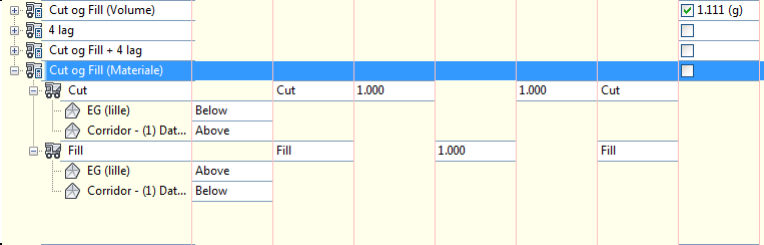
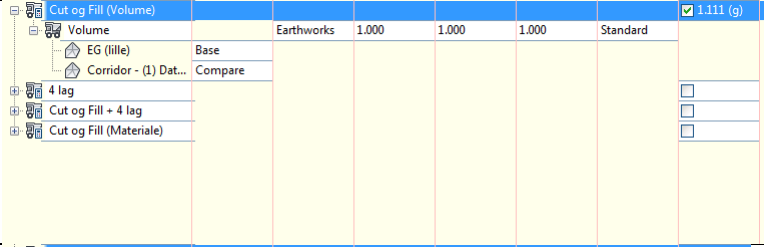
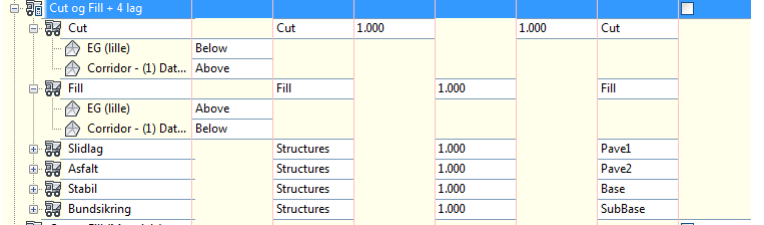
Quantity Takeoff Criteria	Description	Screen grab / DWF / DWG	Default
4 lag			
Cut og Fill (Materiale)			
Cut og Fill (Volume)			
Cut og Fill + 4 lag			

QTO Table Styles	Description	Screen grab / DWF / DWG	Default																																																																																																																																																																																
Total Volume																																																																																																																																																																																			
Cut og Fill		<table border="1"> <thead> <tr> <th colspan="8">TOTAL VOLUME</th> </tr> <tr> <th>STATION</th> <th>CUT M<sup>3</sup></th> <th>FILL M<sup>3</sup></th> <th>CUT M<sup>3</sup></th> <th>FILL M<sup>3</sup></th> <th>AKK. CUT M<sup>3</sup></th> <th>AKK. FILL M<sup>3</sup></th> <th>NETTO M<sup>3</sup></th> </tr> </thead> <tbody> <tr><td>0+000</td><td>3.28</td><td>0.67</td><td>0.00</td><td>0.00</td><td>0.00</td><td>0.00</td><td>0.00</td></tr> <tr><td>0+020</td><td>3.19</td><td>0.80</td><td>64.77</td><td>14.71</td><td>64.77</td><td>14.71</td><td>50.06</td></tr> <tr><td>0+040</td><td>3.14</td><td>0.86</td><td>63.35</td><td>16.55</td><td>128.12</td><td>31.26</td><td>96.86</td></tr> <tr><td>0+060</td><td>2.87</td><td>1.17</td><td>60.14</td><td>20.28</td><td>188.26</td><td>51.54</td><td>136.72</td></tr> <tr><td>0+080</td><td>2.60</td><td>1.50</td><td>54.75</td><td>26.70</td><td>243.01</td><td>78.24</td><td>164.77</td></tr> <tr><td>0+100</td><td>2.33</td><td>1.84</td><td>49.29</td><td>33.41</td><td>292.30</td><td>111.64</td><td>180.66</td></tr> <tr><td>0+120</td><td>2.02</td><td>2.25</td><td>43.44</td><td>40.89</td><td>335.74</td><td>152.54</td><td>183.21</td></tr> <tr><td>0+140</td><td>1.64</td><td>2.76</td><td>36.54</td><td>50.05</td><td>372.28</td><td>202.58</td><td>169.70</td></tr> <tr><td>0+160</td><td>1.28</td><td>3.26</td><td>29.15</td><td>60.18</td><td>401.43</td><td>262.77</td><td>138.67</td></tr> <tr><td>0+180</td><td>0.93</td><td>3.80</td><td>22.12</td><td>70.67</td><td>423.55</td><td>333.44</td><td>90.11</td></tr> <tr><td>0+200</td><td>0.64</td><td>4.41</td><td>15.71</td><td>82.15</td><td>439.26</td><td>415.59</td><td>23.68</td></tr> <tr><td>0+220</td><td>0.34</td><td>5.03</td><td>9.79</td><td>94.45</td><td>449.06</td><td>510.04</td><td>-60.98</td></tr> <tr><td>0+240</td><td>0.07</td><td>5.71</td><td>4.15</td><td>107.42</td><td>453.21</td><td>617.46</td><td>-164.25</td></tr> <tr><td>0+260</td><td>0.00</td><td>6.55</td><td>0.73</td><td>122.64</td><td>453.93</td><td>740.10</td><td>-286.17</td></tr> <tr><td>0+280</td><td>0.00</td><td>7.42</td><td>0.01</td><td>139.81</td><td>453.94</td><td>879.92</td><td>-425.98</td></tr> <tr><td>0+300</td><td>0.00</td><td>8.24</td><td>0.00</td><td>156.72</td><td>453.94</td><td>1036.64</td><td>-582.70</td></tr> <tr><td>0+320</td><td>0.00</td><td>9.02</td><td>0.00</td><td>172.72</td><td>453.94</td><td>1209.36</td><td>-755.42</td></tr> <tr><td>0+340</td><td>0.00</td><td>9.79</td><td>0.00</td><td>188.24</td><td>453.94</td><td>1397.59</td><td>-943.66</td></tr> <tr><td>0+360</td><td>0.00</td><td>10.17</td><td>0.00</td><td>199.78</td><td>453.94</td><td>1597.37</td><td>-1143.43</td></tr> <tr><td>0+380</td><td>0.00</td><td>10.54</td><td>0.00</td><td>207.29</td><td>453.94</td><td>1804.66</td><td>-1350.72</td></tr> </tbody> </table>	TOTAL VOLUME								STATION	CUT M <sup>3</sup>	FILL M <sup>3</sup>	CUT M <sup>3</sup>	FILL M <sup>3</sup>	AKK. CUT M <sup>3</sup>	AKK. FILL M <sup>3</sup>	NETTO M <sup>3</sup>	0+000	3.28	0.67	0.00	0.00	0.00	0.00	0.00	0+020	3.19	0.80	64.77	14.71	64.77	14.71	50.06	0+040	3.14	0.86	63.35	16.55	128.12	31.26	96.86	0+060	2.87	1.17	60.14	20.28	188.26	51.54	136.72	0+080	2.60	1.50	54.75	26.70	243.01	78.24	164.77	0+100	2.33	1.84	49.29	33.41	292.30	111.64	180.66	0+120	2.02	2.25	43.44	40.89	335.74	152.54	183.21	0+140	1.64	2.76	36.54	50.05	372.28	202.58	169.70	0+160	1.28	3.26	29.15	60.18	401.43	262.77	138.67	0+180	0.93	3.80	22.12	70.67	423.55	333.44	90.11	0+200	0.64	4.41	15.71	82.15	439.26	415.59	23.68	0+220	0.34	5.03	9.79	94.45	449.06	510.04	-60.98	0+240	0.07	5.71	4.15	107.42	453.21	617.46	-164.25	0+260	0.00	6.55	0.73	122.64	453.93	740.10	-286.17	0+280	0.00	7.42	0.01	139.81	453.94	879.92	-425.98	0+300	0.00	8.24	0.00	156.72	453.94	1036.64	-582.70	0+320	0.00	9.02	0.00	172.72	453.94	1209.36	-755.42	0+340	0.00	9.79	0.00	188.24	453.94	1397.59	-943.66	0+360	0.00	10.17	0.00	199.78	453.94	1597.37	-1143.43	0+380	0.00	10.54	0.00	207.29	453.94	1804.66	-1350.72	
TOTAL VOLUME																																																																																																																																																																																			
STATION	CUT M <sup>3</sup>	FILL M <sup>3</sup>	CUT M <sup>3</sup>	FILL M <sup>3</sup>	AKK. CUT M <sup>3</sup>	AKK. FILL M <sup>3</sup>	NETTO M <sup>3</sup>																																																																																																																																																																												
0+000	3.28	0.67	0.00	0.00	0.00	0.00	0.00																																																																																																																																																																												
0+020	3.19	0.80	64.77	14.71	64.77	14.71	50.06																																																																																																																																																																												
0+040	3.14	0.86	63.35	16.55	128.12	31.26	96.86																																																																																																																																																																												
0+060	2.87	1.17	60.14	20.28	188.26	51.54	136.72																																																																																																																																																																												
0+080	2.60	1.50	54.75	26.70	243.01	78.24	164.77																																																																																																																																																																												
0+100	2.33	1.84	49.29	33.41	292.30	111.64	180.66																																																																																																																																																																												
0+120	2.02	2.25	43.44	40.89	335.74	152.54	183.21																																																																																																																																																																												
0+140	1.64	2.76	36.54	50.05	372.28	202.58	169.70																																																																																																																																																																												
0+160	1.28	3.26	29.15	60.18	401.43	262.77	138.67																																																																																																																																																																												
0+180	0.93	3.80	22.12	70.67	423.55	333.44	90.11																																																																																																																																																																												
0+200	0.64	4.41	15.71	82.15	439.26	415.59	23.68																																																																																																																																																																												
0+220	0.34	5.03	9.79	94.45	449.06	510.04	-60.98																																																																																																																																																																												
0+240	0.07	5.71	4.15	107.42	453.21	617.46	-164.25																																																																																																																																																																												
0+260	0.00	6.55	0.73	122.64	453.93	740.10	-286.17																																																																																																																																																																												
0+280	0.00	7.42	0.01	139.81	453.94	879.92	-425.98																																																																																																																																																																												
0+300	0.00	8.24	0.00	156.72	453.94	1036.64	-582.70																																																																																																																																																																												
0+320	0.00	9.02	0.00	172.72	453.94	1209.36	-755.42																																																																																																																																																																												
0+340	0.00	9.79	0.00	188.24	453.94	1397.59	-943.66																																																																																																																																																																												
0+360	0.00	10.17	0.00	199.78	453.94	1597.37	-1143.43																																																																																																																																																																												
0+380	0.00	10.54	0.00	207.29	453.94	1804.66	-1350.72																																																																																																																																																																												
Material																																																																																																																																																																																			

Areal og volume			Materiale tabel			
			Station	Areal	Volume	Akk. volume
			0.00	3.28	0.00	0.00
			20.00	3.19	64.77	64.77
			40.00	3.14	63.35	128.12
			60.00	2.87	60.14	188.26
			80.00	2.60	54.75	243.01
			100.00	2.33	49.29	292.30
			120.00	2.02	43.44	335.74
			140.00	1.64	36.54	372.28
			160.00	1.28	29.15	401.43
			180.00	0.93	22.12	423.55
			200.00	0.64	15.71	439.26
			220.00	0.34	9.79	449.06
			240.00	0.07	4.15	453.21
			260.00	0.00	0.73	453.93
			280.00	0.00	0.01	453.94
			300.00	0.00	0.00	453.94
			320.00	0.00	0.00	453.94
			340.00	0.00	0.00	453.94
360.00	0.00	0.00	453.94			
380.00	0.00	0.00	453.94			

Asfalt			Asfalt				
	Station	Areal	Volume	Akk. volume			
	0.00	0.15	0.00	0.00			
	20.00	0.15	3.00	3.00			
	40.00	0.15	3.00	6.00			
	60.00	0.15	3.00	9.00			
	80.00	0.15	3.00	12.00			
	100.00	0.15	3.00	15.00			
	120.00	0.15	3.00	18.00			
	140.00	0.15	3.00	21.00			
	160.00	0.15	3.00	24.00			
	180.00	0.15	3.00	27.00			
	200.00	0.15	3.00	30.00			
	220.00	0.15	3.00	33.00			
	240.00	0.15	3.00	36.00			
	260.00	0.15	3.00	39.00			
	280.00	0.15	3.00	42.00			
	300.00	0.15	3.00	45.00			
	320.00	0.15	3.00	48.00			
	340.00	0.15	3.00	51.00			
360.00	0.15	3.00	54.00				
380.00	0.15	3.00	57.00				

Bundsikring				Bundsikring			
	Station	Areal	Volume	Akk. volume			
	0.00	1.00	0.00	0.00			
	20.00	1.00	36.00	36.00			
	40.00	1.00	36.00	72.00			
	60.00	1.00	36.00	108.00			
	80.00	1.00	36.00	144.00			
	100.00	1.00	36.00	180.00			
	120.00	1.00	36.00	216.00			
	140.00	1.00	36.00	252.00			
	160.00	1.00	36.00	288.00			
	180.00	1.00	36.00	324.00			
	200.00	1.00	36.00	360.00			
	220.00	1.00	36.00	396.00			
	240.00	1.00	36.00	432.00			
	260.00	1.00	36.00	468.00			
	280.00	1.00	36.00	504.00			
	300.00	1.00	36.00	540.00			
	320.00	1.00	36.00	576.00			
	340.00	1.00	36.00	612.00			
360.00	1.00	36.00	648.00				
380.00	1.00	36.00	684.00				

Cut	Cut			
	Station	Areal	Volume	Akk. volume
	0.00	3.28	0.00	0.00
	20.00	3.19	64.77	64.77
	40.00	3.14	63.35	128.12
	60.00	2.87	60.14	188.26
	80.00	2.60	54.75	243.01
	100.00	2.33	49.29	292.30
	120.00	2.02	43.44	335.74
	140.00	1.64	36.54	372.28
	160.00	1.28	29.15	401.43
	180.00	0.93	22.12	423.55
	200.00	0.64	15.71	439.26
	220.00	0.34	9.79	449.06
	240.00	0.07	4.15	453.21
	260.00	0.00	0.73	453.93
	280.00	0.00	0.01	453.94
	300.00	0.00	0.00	453.94
	320.00	0.00	0.00	453.94
	340.00	0.00	0.00	453.94
360.00	0.00	0.00	453.94	
380.00	0.00	0.00	453.94	

Fill	Fill			
	Station	Areal	Volume	Akk. volume
	0.00	0.67	0.00	0.00
	20.00	0.80	14.71	14.71
	40.00	0.86	16.55	31.26
	60.00	1.17	20.28	51.54
	80.00	1.50	26.70	78.24
	100.00	1.84	33.41	111.64
	120.00	2.25	40.89	152.54
	140.00	2.76	50.05	202.58
	160.00	3.26	60.18	262.77
	180.00	3.80	70.67	333.44
	200.00	4.41	82.15	415.59
	220.00	5.03	94.45	510.04
	240.00	5.71	107.42	617.46
	260.00	6.55	122.57	740.03
	280.00	7.42	139.71	879.73
	300.00	8.24	156.58	1036.32
	320.00	9.02	172.57	1208.89
	340.00	9.79	188.10	1396.99
360.00	10.17	199.64	1596.63	
380.00	10.54	207.13	1803.75	

Slidlag	Slidlag			
	Station	Areal	Volume	Akk. volume
	0.00	0.15	0.00	0.00
	20.00	0.15	3.00	3.00
	40.00	0.15	3.00	6.00
	60.00	0.15	3.00	9.00
	80.00	0.15	3.00	12.00
	100.00	0.15	3.00	15.00
	120.00	0.15	3.00	18.00
	140.00	0.15	3.00	21.00
	160.00	0.15	3.00	24.00
	180.00	0.15	3.00	27.00
	200.00	0.15	3.00	30.00
	220.00	0.15	3.00	33.00
	240.00	0.15	3.00	36.00
	260.00	0.15	3.00	39.00
	280.00	0.15	3.00	42.00
	300.00	0.15	3.00	45.00
	320.00	0.15	3.00	48.00
	340.00	0.15	3.00	51.00
360.00	0.15	3.00	54.00	
380.00	0.15	3.00	57.00	



Stabil	Stabil			
	Station	Areal	Volume	Akk. volume
	0.00	0.60	0.00	0.00
	20.00	0.60	12.00	12.00
	40.00	0.60	12.00	24.00
	60.00	0.60	12.00	36.00
	80.00	0.60	12.00	48.00
	100.00	0.60	12.00	60.00
	120.00	0.60	12.00	72.00
	140.00	0.60	12.00	84.00
	160.00	0.60	12.00	96.00
	180.00	0.60	12.00	108.00
	200.00	0.60	12.00	120.00
	220.00	0.60	12.00	132.00
	240.00	0.60	12.00	144.00
	260.00	0.60	12.00	156.00
	280.00	0.60	12.00	168.00
	300.00	0.60	12.00	180.00
	320.00	0.60	12.00	192.00
	340.00	0.60	12.00	204.00
360.00	0.60	12.00	216.00	
380.00	0.60	12.00	228.00	

**7.12 Plan and Profile Sheets**

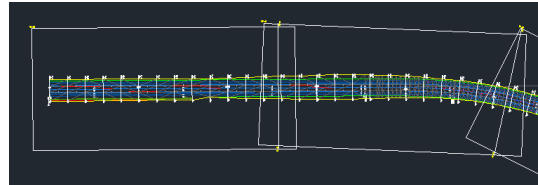
View Frame Sheet Templates	Description	Screen grab / DWF / DWG	Default
_AutoCAD Civil 3D A1 Plan_DK	Indeholder følgende mål forhold for A1: A1 Plan 1-1000 A1 Plan 1-2000 A1 Plan 1-500		
_AutoCAD Civil 3D A1 Plan+Profil_DK	Indeholder følgende mål forhold for A1: A1 Plan over Profil 1-1000 A1 Plan over Profil 1-2000 A1 Plan over Profil 1-500 A1 Plan under Profil 1-1000 A1 Plan under Profil 1-2000 A1 Plan under Profil 1-500		

_AutoCAD Civil 3D A3 Plan_DK	Indeholder følgende mål forhold for A3 (stående): A3 Plan 1-1000 A3 Plan 1-2000 A3 Plan 1-500		
_AutoCAD Civil 3D A3L Plan_DK	Indeholder følgende mål forhold for A3 (liggende): A3L Plan 1-1000 A3L Plan 1-2000 A3L Plan 1-500		

View Frame Styles	Description	Screen grab / DWF / DWG	Default
<Ingen>			

View Frame Label Styles	Description	Screen grab / DWF / DWG	Default
<Ingen>			

Match Line Styles	Description	Screen grab / DWF / DWG	Default
<Ingen>			

Match Line Label Styles	Description	Screen grab / DWF / DWG	Default
Match Line Left			
<Ingen>			
Match Line Right			
<Ingen>			

**7.13 Survey**

Network Styles	Description	Screen grab / DWF / DWG	Default
<Ingen>			

Figure Styles	Description	Screen grab / DWF / DWG	Default
<Ingen>			

## 8 Tool palette(s)

### 8.1 Tværprofiler

---

#### 8.1.1 Subassemblies

<Ingen>

#### 8.1.2 Assemblies

Figur nedenfor viser liste med tegninger med dansk standard tværprofiler, som kan anvendes i forbindelse med automatisk opret af kryds.

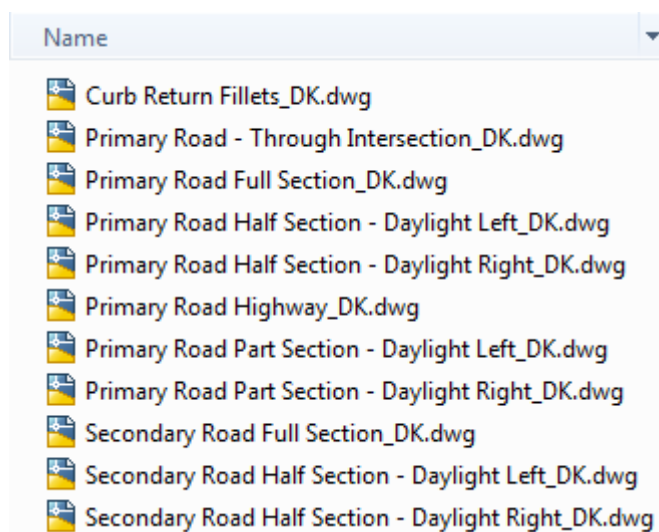

### 8.2 Material styles

---

<Ingen>

### 8.3 Drawing symbols and (MV) Blocks

---

<Ingen>

## 9 Pipe and Structure Catalogs

Der er oprettet 4 forskellige Parts Lists til projektering af ledninger og komponenter. Det er Spildevand, Regnvand, Fælles og Dræn. Se figur nedenfor.



Hver Parts Lists er oprettet egne Civil 3D styles, som styrer udseende og farver. Lag ved start af netværk og dermed også Parts List (system) er 0. Der findes lag til de enkelte Parts Lists. Tabel nedenfor viser dette.

System	Farve	AutoCAD Lag
Spildevand	Rød	C-PIPE-SPV
Regnvand	Blå	C-PIPE-RGV
Fælles	Rød	C-PIPE-FLS
Dræn	Grøn	C-PIPE-DRN
Standard	Sort/hvid	0

Afsnit 10.1 til 10.4 beskriver de enkelte Parts Lists (system), som de også er nævnt i tabel ovenfor.

### 9.1 Spildevand

Figur nedenfor viser materiale og dimensioner for ledninger til Spildevand.

Spildevand						
Beton						
150	Spildevand	Spildevand	Global	Beton-150		
200	Spildevand	Spildevand	Global	Beton-200		
250	Spildevand	Spildevand	Global	Beton-250		
300	Spildevand	Spildevand	Global	Beton-300		
400	Spildevand	Spildevand	Global	Beton-400		
500	Spildevand	Spildevand	Global	Beton-500		
600	Spildevand	Spildevand	Global	Beton-600		
PVC						
110 mm	Spildevand	Spildevand	Global	PVC-110		
160 mm	Spildevand	Spildevand	Global	PVC-160		
200 mm	Spildevand	Spildevand	Global	PVC-200		
250 mm	Spildevand	Spildevand	Global	PVC-250		
315 mm	Spildevand	Spildevand	ByLayer	PVC-315		
400 mm	Spildevand	Spildevand	ByLayer	PVC-400		
500 mm	Spildevand	Spildevand	ByLayer	PVC-500		
LER						
50 mm	Spildevand	Spildevand	ByLayer	LER-50		
63 mm	Spildevand	Spildevand	ByLayer	LER-63		
75 mm	Spildevand	Spildevand	ByLayer	LER-75		
90 mm	Spildevand	Spildevand	ByLayer	LER-90		
110 mm	Standard	Standard	ByLayer	LER-110		
160 mm	Standard	Standard	ByLayer	LER-160		

Figur nedenfor viser typer og dimensioner for komponenter til Spildevand.

Spildevand						
Eccentrisk Cylindrisk Top cirkel						
Brønd 1.0 dia	Spildevand	Spildevand	Global	ECT-1000		
Brønd 1.25 dia	Spildevand	Spildevand	Global	ECT-1250		
Brønd 1.5 dia	Spildevand	Spildevand	Global	ECT-1500		
Brønd 2.0 dia	Spildevand	Spildevand	Global	ECT-2000		
Brønd 2.5 dia	Spildevand	Spildevand	Global	ECT-2500		
Brønd 3.0 dia	Spildevand	Spildevand	Global	ECT-3000		
Brønd 4.0 dia	Spildevand	Spildevand	Global	ECT-4000		
Centrisk cylindrisk Top cirkel						
Brønd 1.0 dia	Spildevand	Spildevand	Global	CCT-1000		
Brønd 1.25 dia	Spildevand	Spildevand	Global	CCT-1250		
Brønd 1.5 dia	Spildevand	Spildevand	Global	CCT-1500		
Brønd 2.0 dia	Spildevand	Spildevand	Global	CCT-2000		
Brønd 2.5 dia	Spildevand	Spildevand	Global	CCT-2500		
Brønd 3.0 dia	Spildevand	Spildevand	Global	CCT-3000		
Brønd 4.0 dia	Spildevand	Spildevand	Global	CCT-4000		
Null Structure						

## 9.2 Regnvand

Figur nedenfor viser materiale og dimensioner for ledninger til Regnvand.

Regnvand					
Beton					
150	Regnvand	Regnvand	ByLayer	Beton-150	
200	Regnvand	Regnvand	ByLayer	Beton-200	
250	Regnvand	Regnvand	ByLayer	Beton-250	
300	Regnvand	Regnvand	ByLayer	Beton-300	
400	Regnvand	Regnvand	ByLayer	Beton-400	
500	Regnvand	Regnvand	ByLayer	Beton-500	
600	Regnvand	Regnvand	ByLayer	Beton-600	
PVC					
110 mm	Regnvand	Regnvand	ByLayer	PVC-110	
160 mm	Regnvand	Regnvand	ByLayer	PVC-160	
200 mm	Regnvand	Regnvand	ByLayer	PVC-200	
250 mm	Regnvand	Regnvand	ByLayer	PVC-250	
315 mm	Regnvand	Regnvand	ByLayer	PVC-315	
400 mm	Regnvand	Regnvand	ByLayer	PVC-400	
500 mm	Regnvand	Regnvand	ByLayer	PVC-500	
LER					
50 mm	Regnvand	Regnvand	ByLayer	LER-50	
63 mm	Regnvand	Regnvand	ByLayer	LER-63	
75 mm	Regnvand	Regnvand	ByLayer	LER-75	
90 mm	Regnvand	Regnvand	ByLayer	LER-90	
110 mm	Standard	Regnvand	ByLayer	LER-110	
160 mm	Standard	Regnvand	ByLayer	LER-160	

Figur nedenfor viser typer og dimensioner for komponenter til Regnvand.

Regnvand					
Excentrisk Cylindrisk Top cirkel					
Brønd 1.0 dia	Regnvand	Regnvand	ByLayer	ECT-1000	
Brønd 1.25 dia	Regnvand	Regnvand	ByLayer	ECT-1250	
Brønd 1.5 dia	Regnvand	Regnvand	ByLayer	ECT-1500	
Brønd 2.0 dia	Regnvand	Regnvand	ByLayer	ECT-2000	
Brønd 2.5 dia	Regnvand	Regnvand	ByLayer	ECT-2500	
Brønd 3.0 dia	Regnvand	Regnvand	ByLayer	ECT-4000	
Brønd 4.0 dia	Regnvand	Regnvand	ByLayer	ECT-4000	
Centrisk cylindrisk Top cirkel					
Brønd 1.0 dia	Regnvand	Regnvand	ByLayer	CCT-1000	
Brønd 1.25 dia	Regnvand	Regnvand	ByLayer	CCT-1250	
Brønd 1.5 dia	Regnvand	Regnvand	ByLayer	CCT-1500	
Brønd 2.0 dia	Regnvand	Regnvand	ByLayer	CCT-2000	
Brønd 2.5 dia	Regnvand	Regnvand	ByLayer	CCT-2500	
Brønd 3.0 dia	Regnvand	Regnvand	ByLayer	CCT-3000	
Brønd 4.0 dia	Regnvand	Regnvand	ByLayer	CCT-4000	
Null Structure					
Cylinder uden Top					
315 mm	Regnvand	Regnvand	ByLayer	CT-315	
425 mm	Regnvand	Regnvand	ByLayer	CT-425	
600 mm	Regnvand	Regnvand	ByLayer	CT-600	
Riste					
35x35cm	Regnvand	Regnvand	ByLayer	RIST-35x35	

### 9.3 Fælles

Figur nedenfor viser materiale og dimensioner for ledninger til Fælles.

Fælles						
Beton						
150	Fælles	Fælles	ByLayer	Beton-150		
200	Fælles	Fælles	ByLayer	Beton-200		
250	Fælles	Fælles	ByLayer	Beton-250		
300	Fælles	Fælles	ByLayer	Beton-300		
400	Fælles	Fælles	ByLayer	Beton-400		
500	Fælles	Fælles	ByLayer	Beton-500		
600	Fælles	Fælles	ByLayer	Beton-600		
PVC						
110 mm	Fælles	Fælles	ByLayer	PVC-110		
160 mm	Fælles	Fælles	ByLayer	PVC-160		
200 mm	Fælles	Fælles	ByLayer	PVC-200		
250 mm	Fælles	Fælles	ByLayer	PVC-250		
315 mm	Fælles	Fælles	ByLayer	PVC-315		
400 mm	Fælles	Fælles	ByLayer	PVC-400		
500 mm	Fælles	Fælles	ByLayer	PVC-500		
LER						
50 mm	Fælles	Fælles	ByLayer	LER-50		
63 mm	Fælles	Fælles	ByLayer	LER-63		
75 mm	Fælles	Fælles	ByLayer	LER-75		
90 mm	Fælles	Fælles	ByLayer	LER-90		
110 mm	Fælles	Fælles	ByLayer	LER-110		
160 mm	Fælles	Fælles	ByLayer	LER-160		

Figur nedenfor viser typer og dimensioner for komponenter til Fælles.

Fælles						
Eccentrisk Cylindrisk Top cirkel						
Brønd 1.0 dia	Fælles	Spildevand	ByLayer	ECT-1000		
Brønd 1.25 dia	Fælles	Spildevand	ByLayer	ECT-1250		
Brønd 1.5 dia	Fælles	Spildevand	ByLayer	ECT-1500		
Brønd 2.0 dia	Fælles	Spildevand	ByLayer	ECT-2000		
Brønd 2.5 dia	Fælles	Spildevand	ByLayer	ECT-2500		
Brønd 3.0 dia	Fælles	Spildevand	ByLayer	ECT-3000		
Brønd 4.0 dia	Fælles	Spildevand	ByLayer	ECT-4000		
Centrisk cylindrisk Top cirkel						
Brønd 1.0 dia	Fælles	Spildevand	ByLayer	CCT-1000		
Brønd 1.25 dia	Fælles	Spildevand	ByLayer	CCT-1250		
Brønd 1.5 dia	Fælles	Spildevand	ByLayer	CCT-1500		
Brønd 2.0 dia	Fælles	Spildevand	ByLayer	CCT-2000		
Brønd 2.5 dia	Fælles	Spildevand	ByLayer	CCT-2500		
Brønd 3.0 dia	Fælles	Spildevand	ByLayer	CCT-3000		
Brønd 4.0 dia	Fælles	Spildevand	ByLayer	CCT-4000		
Null Structure						
Cylinder uden Top						
315 mm	Fælles	Standard	ByLayer	CT-315		
425 mm	Fælles	Standard	ByLayer	CT-425		
600 mm	Fælles	Standard	ByLayer	CT-600		

### 9.4 Dræn

Figur nedenfor viser materiale og dimension for ledninger til Dræn.

Dræn						
PVC						
74/65 mm	Dræn	Dræn	ByLayer	DRN-65		
92/80 mm	Dræn	Dræn	ByLayer	DRN-80		
128/113 mm	Dræn	Dræn	ByLayer	DRN-113		
160/145 mm	Dræn	Dræn	ByLayer	DRN-145		

Figur nedenfor viser type for komponenter til Dræn.

Dræn						
Null Structure						

### 9.5 Labels

For hvert system findes labels, som kan bruges til plotredigering af data for komponenter og ledninger. Figur nedenfor viser dette for Spildevand i Plan view.

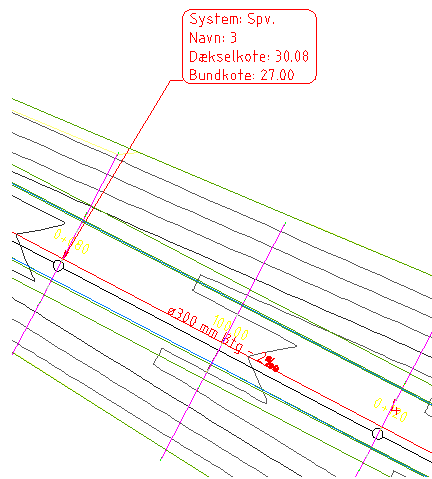

Det samme gælder de andre systemer. De har blot andre farver. De samme plotredigeringer kan køres i Model, Profile og Section views.

### 9.6 Tabel

Figur nedenfor viser tabel med ledningsdata for et netværk/system.

LEDNINGER						
Net - (4)						
NUMMER	DIM	MATERIALE	LÆNGDE	FALD	START KOMPONENT	SLUT KOMPONENT
(1)	250	Beton	205.99	12‰	1	2
(2)	250	Beton	188.69	2‰	2	3
(3)	250	Beton	122.60	2‰	3	4



Figur nedenfor viser tabel med komponentdata for et netværk/system.

KOMPONENTER								
Net -  4								
NUMMER	MATERIALE	X	Y	DÆKSELKOTE	BUNDKOTE	SUMP	LEDNING IND	LEDNING UD
1	Beton	-220589.317	341366.188	28.739	27.447	0.000		1  Dim=250 VG=27.447
2	Beton	-221429.409	341497.391	27.770	24.864	0.000	1  Dim=250 VG=24.96	2  Dim=250 VG=24.864
3	Beton	-220243.802	340537.352	27.510	24.384	0.000	2  Dim=250 VG=24.48	3  Dim=250 VG=24.384
4	Beton	-220121.491	340556.439	26.843	24.136	0.000	3  Dim=250 VG=24.14	

For begge tabel typer gælder, at de kan være dynamiske.

## 10 Highway design check files - vejregler

Vejregler bruges til opret af linieføringer, vejprofiler og korridorer, så projektering af disse sker efter lokal standard. Såfremt vejregler ikke overholdes vil det i tegningen vises med en markør (advarsel). Figur nedenfor viser advarsel på linieføring oprettet med vejregler.

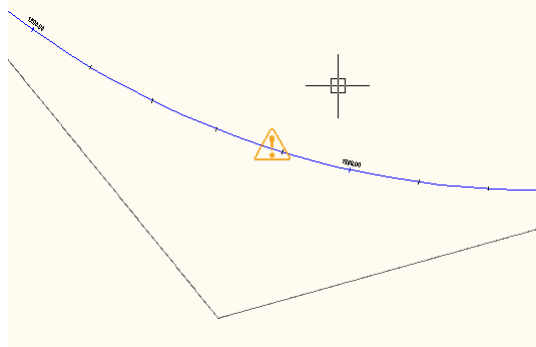

Indstillingerne i vejregler bruges også til automatisk beregning af overhøjde for kurver og overgangskurver. Figur nedenfor viser tværprofil med beregnet overhøjde for en kurve gående mod højre. Se kapitel 12.

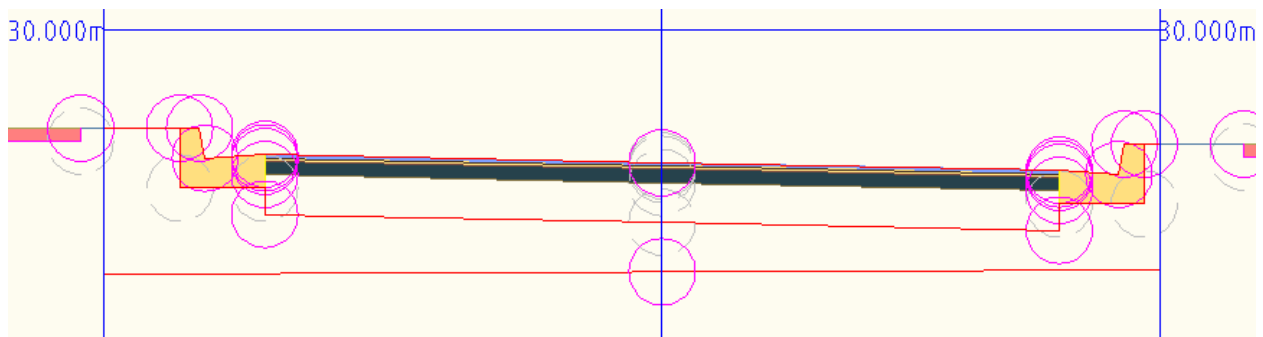

Vejregler er lagret i filen <\_Civil 3D Vej kriterier\_DK.xml>. Figur nedenfor viser den lokale standard for vejregler.

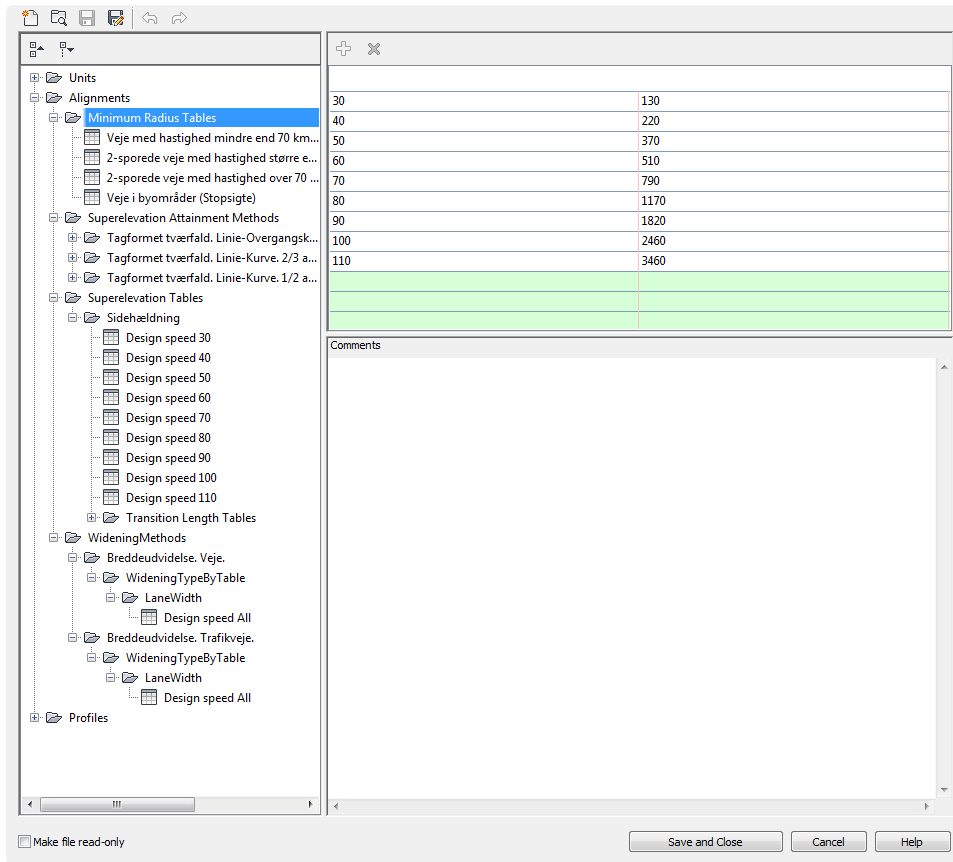

Figur nedenfor viser i Civil 3D, hvor den interne editor for vejregler kan køres fra.

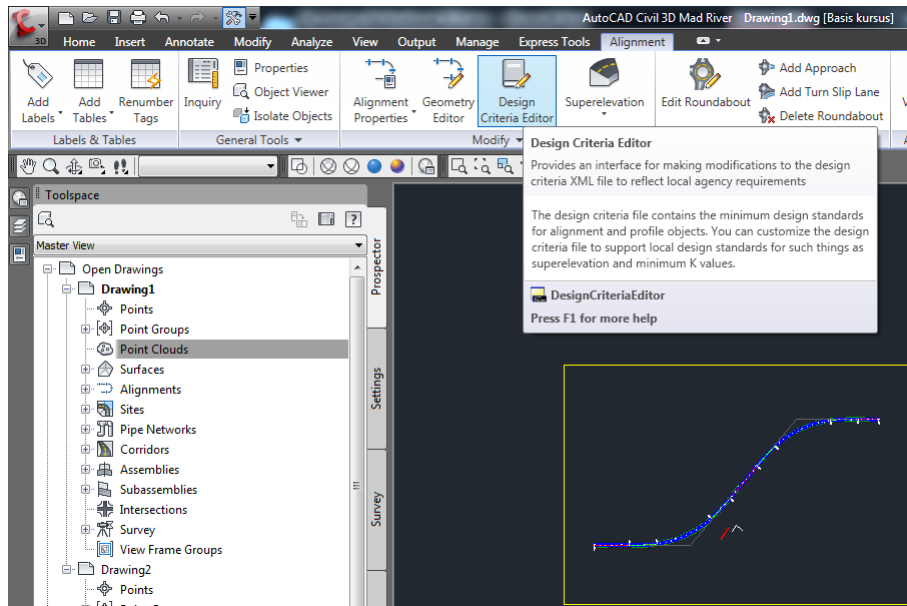

## 11 Quantity Take Off

### 11.1 Introduktion til QTO

I Civil 3D er det muligt, at skabe en forbindelse mellem en master "element liste" (pay item list) og objekter i en Civil 3D tegning. Forbindelse sker på 2 niveauer:

1. Automatisk via indstillinger i template. Fx korridor elementer, ledninger eller komponenter, der automatisk peger på "elementliste"
2. Udpeg af arealer, polylinier eller feature lines med manuel udpegning af element i "element liste"

Har objekter i Civil 3D tegningen forbindelse til "element liste", så kan der umiddelbart køres en rapport, som udskriver arealer og længder for objekter, der er tildelt element i "element liste".

Figur nedenfor viser rapport med optælling af elementer.

<u>Samlet QTO rapport</u>			
Element	Beskrivelse	Antal	Enhed
CCT-1250	1250 mm	6	EA
CorrAreal-Datum	Datum	30358.44	M2
CorrAreal-Daylight	Daylight	4747.74	M2
CorrAreal-Fortov	Fortov	12111.26	M2
CorrAreal-Kørebane	Kørebane	10092.72	M2
CorrAreal-Top	Top	30361.80	M2
CorrLgd-Fortov	Fortov	3364.294	M1
PVC-200	PVC 200 mm	200.394	M1
PolyLgd-Basis	Polyline	761.667	M1

Det er muligt at lave optællinger af forskellige typer baseret på antal, areal eller længde. Fx findes 761.667m polylinie i Civil 3D tegningen, som ikke er korridor elementer eller ledninger.

Det enkelte element i "element liste" kan udvides med en formel, hvor man fx multiplicerer elementets optælling med en kortpris. På denne måde er det fx meget nemt, at beregne prisen på kantsten.

Informationer fra QTO kan ses i rapporter (CSV, HTML eller TXT) eller eksporteres til anvendelse i andre 3. Parts beregningsprogrammer.

### 11.2 Indstillinger af QTO

#### 11.2.1 Element liste - Master Pay Items List

<Pay Item Data\Denmark\\_DK standard.csv> er "element listen".

Det er en CSV fil, som kan rettes med Microsoft Excel eller med Notepad. CSV filen indeholder elementer, som kan forbindes til Civil 3D objekter og almindelige AutoCAD for optælling i meter, areal og volumen.

### 11.2.2 Kategorier - Pay Items Index

<..\Pay Item Data\Denmark\\_DK standard.xml> anvendes til inddeling af elementer i "element liste". Fx er det muligt at gruppere efter:

- Ledninger
- Komponenter
- Korridor elementer

Filen kan rettes med XML editor.

### 11.2.3 Enheder - Units Mapping Fil

<Pay Item Data\Units\QTOUnits.xml> filen indeholder definition af enheder generelt, men også globalt.

Unit	Description
EA	Each (optælling af antal brønde med en bestemt type)
M1	Meter
M2	Kvadrat meter
M3	Kubik meter

### 11.2.4 Rapport

QTO rapporter udskrives til HTML style sheets (.XSL) filer med QTO optællinger fra den aktuelle tegning. Herefter er det muligt at skifte til visning af CSV, HTML eller TXT format.

Danske varianter er gemt i mappen <Takeoff Report Style Sheets> under %DataDir% mappen.

## 12 Superelevation standards - overhøjde

Vejregler, se kapitel 10, bruges også til automatisk beregning af overhøjde for kurver med eller uden overgangskurver. Vejregler er lagret i filen <\_Civil 3D Vej kriterier\_DK.xml>.

Figur nedenfor viser indstillinger for beregning af overhøjde i kurver og overgangskurver.

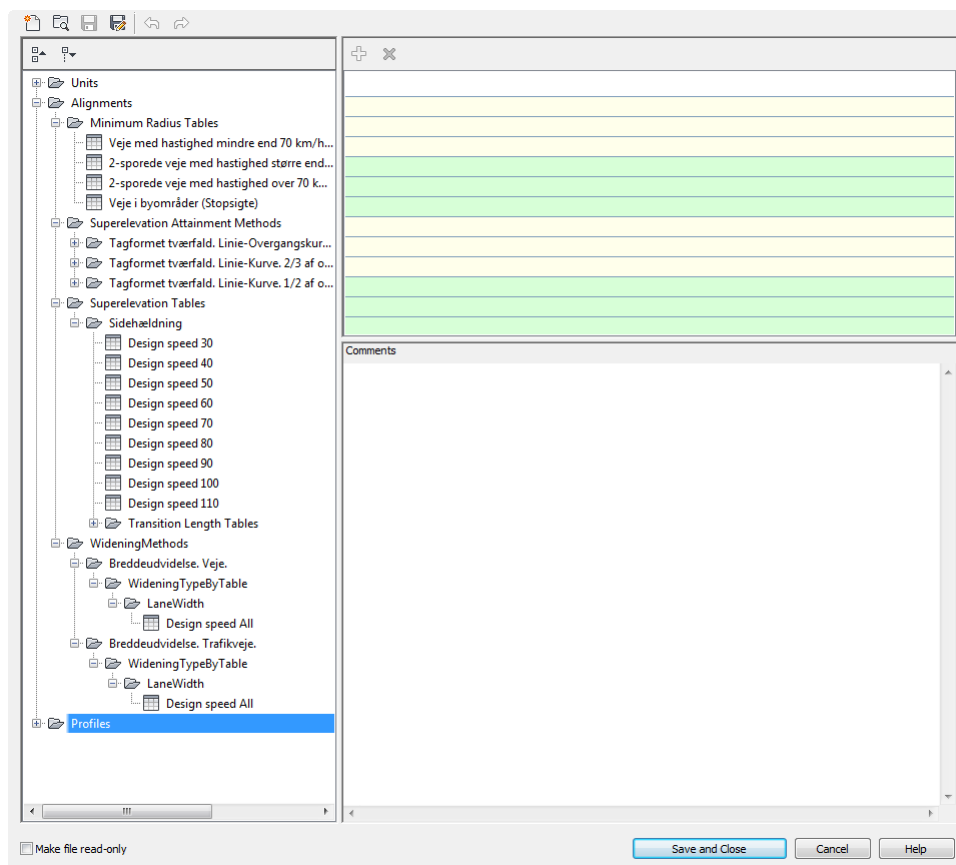

Figur nedenfor viser tværprofil med beregnet overhøjde for en kurve gående mod højre.

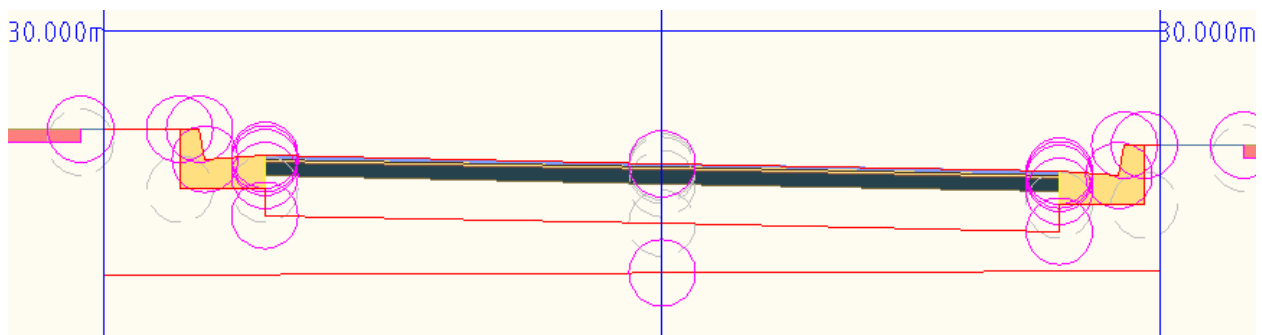

Figur nedenfor viser skema for beregnet overhøjde.

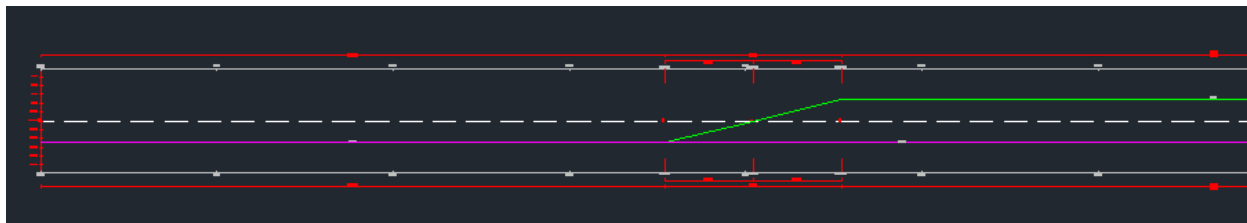

Figur nedenfor viser samme skema for beregnet overhøjde, men viser samtidig, at det er muligt rent grafisk at "flytte" start og slut samt størrelsen på beregnet overhøjde. For Danmark gælder dog, at overhøjden aldrig må overstige 7%.

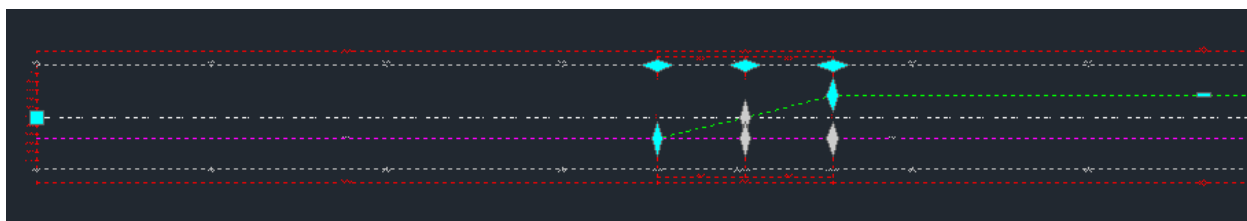

Endvidere skal der gøres opmærksom på, at det ikke er muligt at tilpasse angivelsen af hældninger og diverse andre tekster, da der ikke findes stilart herfor. Det er kun muligt at tilpasse farver for skema og dennes automatisk generede tekster.

### 13 Kryds - stilarter, navn og tværprofiler

Tabel nedenfor viser indstillinger i forbindelse med opret af kryds.

General type	Name	Value	Comments
Default Styles			
	Intersection Style	Basis	
	Intersection Label Style	Basis	
	Offset Alignment Style	Veje parallelt	Som Veje, men linetype er HIDDEN
	Curb Return Alignment Style	Veje parallelt	Som Veje, men linetype er HIDDEN
	Offset Profile Style	Vejprofil	
	Curb Return Profile Style	Vejprofil	
	Offset Alignment Label Set	Basis	
	Curb Return Alignment Label Set	Basis	
Default Name Format			
	Intersection Name Format	Kryds - (<[Next Counter(CP)]>)	
	Intersection Quadrant Name Format	<[Quadrant Location]> - Quadrant	
	Offset Alignment Name Format	<[Parent Alignment Name(CP)]>-<[Side]>-<[Offset Value(Um   P3   RN   Sn   OF   AP)]>	
	Curb Return Alignment Name Format	<[Intersection Name(CP)]> - <[Intersection Quadrant Name(CP)]>	
	Offset Profile Name Format	<[Parent Alignment Name(CP)]> - <[Side]> - <[Cross Slope Value(FRise   P2   RN   Sn   OF   AP)]>	
	Curb Return Profile Name Format	<[Alignment Name(CP)]> - Profile	
	Corridor Region Name Format	RG - <[Assembly Name(CP)]> - (<[Next Counter(CP)]>)	

<\_Autodesk (Metric) Assembly Sets DK.xml> er danske indstillinger, som kan vælges i forbindelse med automatisk opret af kryds. Afsnit 9.1 indeholder de tværprofiler, der så kommer i anvendelse under automatisk opret af kryds.

Indstillinger vælges i Wizard vinduet for opret kryds. Figur nedenfor viser dette.



